

Tektronix Logic Analyzer Probes

P64xx/P67xx/P68xx/P69xx Data Sheet



Features & Benefits

- <math><0.7\text{ pF}</math> Total Capacitive Loading Minimizes Intrusion on Circuits
- 20 k Ω Input Resistance
- 6.5 V_{pp} Dynamic Range Supports a Broad Range of Logic Families
- General-purpose Probing Allows Flexible Attachment to Industry-standard Connections
- Connectorless Probing System Eliminates Need for Onboard Connectors

Applications

- Hardware Debug and Verification
- Processor/Bus Debug and Verification
- Embedded Software Integration, Debug, and Verification

Leading Probing Solutions for Real-time Digital Systems Analysis

P64xx Series Probes

No test and measurement solution is complete without probing and the consideration of its impact on your system and your measurement time. With the industry's lowest probe loading, the P6400 Series logic analyzer probes protect the integrity of your signal – minimizing the impact on your design. The P6400 Series logic analyzer probes when used with the TLA5000B Series logic analyzers make sophisticated logic analysis available at an affordable price. Select from a variety of attachment mechanisms, including the high-density D-Max® Probing Technology that eliminates the need for onboard connectors.

- For applications where circuit board space is limited, the high-density P6450 offers the smallest available footprint and a quick connection mechanism.
- With low loading capacitance, the P6400 Series can accurately acquire signals with faster edges without distorting the signal.
- Flexible general-purpose probing, with support for 0.100 in. and 2 mm pin spacing, low input capacitance, and accessories for connecting to many industry-standard connections.

P68xx and P69xx Series Probes

With the industry's lowest capacitance, the P6800 and P6900 Series logic analyzer probes for the TLA7000 protect the integrity of your signal – critical for connecting to fast buses like DDR2 and DDR3 where low intrusion is key to the proper operation of your design. Select from single-ended and differential probes and a variety of attachment mechanisms, including the “connectorless” compression connection that eliminates the need for onboard connectors.

For applications where circuit board space is at a premium, the high-density P6900 Series with D-Max® Probing Technology offers the industry's smallest available footprint. For debugging the signal integrity glitches common on fast buses, the P6900 Series works with the TLA7Bxx and TLA7ACx modules and their iLink™ Tool Set capability to provide iCapture™ simultaneous digital-analog acquisition. This allows you to clearly see the time-correlated digital and analog behavior of your design, without the extra capacitance and setup time of double probing.

For differential signaling applications where signal integrity is critical, the high-fidelity P6980 and P6982 are perfect for those applications where noise performance is critical. In addition, the P6980 and P6982 can support the small voltage swings that differential signaling often requires. The P6962DBL, when used with a TLA7000 logic analyzer with the TLA7Bxx module, supports digital validation and debug of DDR3 memory with data rates up to 1600 mega-transfers per second. For board designs that do not include high-density probe footprints, the P6960 with its companion flying leadset or the P6810 provide the flexibility required to meet many different debug needs.

P67xx Series Probes for PCI Express Gen 2

The P67xx Series probes provide validation engineers with two mid-bus probing options and one solder-down option. The P67xx mid-bus probes are the best choice for minimal system impact. The P67xx use a new “connectorless” retention mechanism that is designed to maximize mechanical reliability. When conserving circuit board space is critical, the P6708 8-channel half-width probe is an ideal choice for designs that use X1 and X4 links. The P6716 16-channel full-width probe is also available. The P6701SD enables customers to validate their PCI Express designs on platforms where no mid-bus or slot connector exists.

Characteristics

P64xx Probe Characteristics

General

Characteristic	P6410	P6419	P6434	P6450
Probe Type	Single-ended Data Single-ended Clock (General Purpose)	Single-ended Data Single-ended Clock (Compression 17-channel)	Single-ended Data Single-ended Clock (Mictor 34-channel)	Single-ended Data Single-ended Clock (D-Max Probing Technology)
Number of Channels	17	17	34	34
Recommended Usage for:	Most general-purpose applications	Applications requiring good signal density and quick reliable attachment	Applications requiring many channels to be quickly connected in a small footprint	Applications requiring many channels to be quickly connected in a small footprint
Attachment to Target System	Fits both 0.100 in. and 2 mm square pin configurations	Compression Elastomer	Amp Mictor 34 Channel Connector	D-Max probing technology compression cLGA
Probe Loading AC/DC	2 pF/20 k Ω to 0 V (TLA5000) <2 pF/20 k Ω to 2.2 V (TLA600, TLA7N/P/Qx)	< 0.7 pF/20 k Ω to 0 V (TLA5000) < 0.7 pF/20 k Ω to 2.2 V (TLA600, TLA7N/P/Qx)	2 pF/20 k Ω to 0 V (TLA5000) 2 pF/20 k Ω to 2.2 V (TLA600, TLA7N/P/Qx)	<0.7 pF/20 k Ω to 0 V (TLA5000) < 0.7 pF/20 k Ω to 2.2 V (TLA600, TLA7N/P/Qx)
Input Range	-5 V to 8 V			
Max Voltage (Nondestruct)	\pm 15 V			
Cable Length	1.8 m (6 ft.)			

P68xx/69xx Probe Characteristics

General

Characteristic	P6810	P6860	P6864	P6880	P6960	P6962 / P6964	P6962DBL	P6980	P6982
Data	Differential	Single-ended	Single-ended	Differential	Single-ended	Single-ended	Single-ended	Differential	Differential
Clock	Differential								
Number of Channels	34	34	17	34	34	34	34	34	17
Number of Probe Heads	1	2	1	4	1	1	1	2	1
Recommended Use	General-purpose applications	Good signal density and quick reliable attachment	Data rates in excess of 750 MHz (TLA7Bxx) or 450 MHz (TLA7ACx) with good signal density	Full differential probing with good signal density	Best signal density and quick reliable attachment. Flying leads for general-purpose probing is optional	Data rates in excess of 750 MHz (TLA7Bxx) or 450 MHz (TLA7ACx) with the best signal density	Highest performance applications, such as the fastest data rate DDR memory	Full differential probing with the best signal density	Full differential with the best signal density for data rates in excess of 750 MHz (TLA7Bxx) or 450 MHz (TLA7ACx)
Attachment to Target System	Fits both 0.100 in. and 2 mm square pin configurations	Compression Elastomer			D-Max® probing technology compression cLGA				
Probe Loading AC/DC	< 0.7 pF/20 kΩ to Ground				0.5 pF/20 kΩ to Ground, typical		0.7 pF/11.7 kΩ to Ground, typical	0.5 pF/20 kΩ to Ground, typical	
Analog Bandwidth	Module Dependent								
TLA7Bxx module	3 GHz through iCapture™ to analog out BNCs*1								
TLA7ACx module	2 GHz through iCapture™ to analog out BNCs*1								
Input Range	-2.5 V to 5.0 V						-1.25 V to +2.5 V	-2.5 V to 5.0 V	
Max Voltage (Nondestruct)	±15 V						±7.5 V	±15 V	
Cable Length	1.8 m (6 ft.)								

*1 Analog bandwidth of P6960 is less with flying lead set attached.

P67xx Probe Characteristics

General

Characteristic	P6708	P6716	P6701S	P6704S	P6708S	P6716S	P6701SD
Probe Type	PCI Express Mid-bus Differential Data	PCI Express Mid-bus Differential Data	PCI Express Slot Interposer	PCI Express Slot Interposer	PCI Express Slot Interposer	PCI Express Slot Interposer	PCI Express Differential Solder-down Probe
Number of Channels	8	16	2	4	16	32	1
Recommended Use	Recommended where signal integrity is critical	Recommended where signal integrity is critical	Recommended for platforms with no mid-bus footprints and the PCI Express slot is the only probe access point	Recommended for platforms with no mid-bus footprints and the PCI Express slot is the only probe access point	Recommended for platforms with no mid-bus footprints and the PCI Express slot is the only probe access point	Recommended for platforms with no mid-bus footprints and the PCI Express slot is the only probe access point	Recommended for platforms with no mid-bus footprint, PCI Express slot, or where space is limited
Attachment to Target System	Compression cSpring	Compression cSpring	PCI Express Slot	PCI Express Slot	PCI Express Slot	PCI Express Slot	Solder Down
Probe Loading AC/DC	See TLA P67xx and P67xxS Probe Manual						
Cable Length	1.8 m (6 ft.)						

Mid-bus Probe Configuration

X1	X4	X8	X16
1 P6708 1 TLA7S08	1 P6708 1 TLA7S08	—	—
1 P6716 1 TLA7S08	1 P6716 1 TLA7S08	—	—
1 P6708 1 TLA7S16	1 P6708 1 TLA7S16	2 P6708 1 TLA7S16	—
1 P6716 1 TLA7S16	1 P6716 1 TLA7S16	1 P6716 1 TLA7S16	2 P6716 2 TLA7S16

Slot Interposer Probe Configurations

X1	X4	X8	X16
1 P6701S 1 TLA7S08	—	—	—
1 P6704S 1 TLA7S08	1 P6704S 1 TLA7S08	—	—
1 P6708S 1 TLA7S16	1 P6708S 1 TLA7S16	1 P6708S 1 TLA7S16	—
1 P6716S 1 TLA7S16	1 P6716S 1 TLA7S16	1 P6716S 1 TLA7S16	1 P6716S 2 TLA7S16

Solder Down Application

Solder Down Probe Configurations

X1	X4	X8	X16
2 P6701SD 1 TLA7S08	8 P6704S 1 TLA7S08	—	—
2 P6701SD 1 TLA7S16	8 P6704S 1 TLA7S16	16 P6704S 1 TLA7S16	32 P6701SD 2 TLA7S16

Parameter

Description*2

Mid-bus Probe	Minimum eye height at footprint pad*2	30 mV (single ended)
	Minimum eye width at footprint pad	0.53 UI if jitter frequency components of ≤ 40 MHz are not present.*3 If jitter frequency components of ≤ 40 MHz are present, then apply the filter function described in the graph to the jitter of the signal. (See user manual Figure 36)
Solder-down Probe	Minimum eye height at footprint pad*2	30 mV (single ended)
	Minimum eye width at footprint pad	0.53 UI if jitter frequency components of ≤ 40 MHz are not present.*3 If jitter frequency components of ≤ 40 MHz are present, then apply the filter function described in the graph to the jitter of the signal. (See user manual Figure 36)
Slot Interposer	Minimum eye height at probe connection point*2	60 mV (single ended)
	Minimum eye width at probe connection point	0.58 UI if jitter frequency components of ≤ 40 MHz are not present.*3 If jitter frequency components of ≤ 40 MHz are present, then apply the filter function described in the graph to the jitter of the signal. (See user manual Figure 36)
Unit Interval Gen1		400 ps
Unit Interval Gen2		200 ps

*2 Eye Height/Width values apply to both data rates.

*3 Requirements valid for 10^{-12} BER. Refer to the user manual for further information.

Ordering Information

Tektronix Logic Analyzer Probes

Models	Description
P6410	17-channel General-purpose Probe with Single-ended Data/Clock with Separable Podlets and Accessories Includes: Podlet Holders, IC Grabbers, Ground Leads, Ground Tips, Extension Ground Tips, Probe Labels, Probe Instruction Manual
P6419	17-channel High-density Compression Probe, with Single-ended Data/Clock and Accessories Includes: Nut Bars, Elastomer Holder (Thin PCBs), Elastomer Holder (Thick PCBs), Probe Labels, Probe Instruction Manual
P6434	34-channel High-density Mictor Probe with Single-ended Data/Clock and Accessories Includes: Latch Housing Assembly (Edge-mount), Latch Housing Assembly (Vertical), Probe Labels, Probe Label Instructions, Probe Instruction Manual
P6450	34-channel High-density D-Max Probing Technology Probe with Single-ended Data/Clock and Accessories Includes: Probe Retention Kit for D-Max Probing Technology, Probe Labels, Probe Instruction Manual
P6708	8-channel PCI Express Mid-bus Probe and Accessories Includes: Statement of Compliance, (2) 8-channel Retention Mechanisms, Velcro Cable Managers, Probe Instruction Manual
P6716	16-channel PCI Express Mid-bus Probe and Accessories Includes: Statement of Compliance, (2) 16-channel Retention Mechanisms, Velcro Cable Managers, Probe Instruction Manual
P6701S	X1 PCI Express Slot Interposer Includes: Statement of Compliance, Velcro Cable Managers, Probe Instruction Manual
P6704S	X4 PCI Express Slot Interposer Includes: Statement of Compliance, Velcro Cable Managers, Probe Instruction Manual
P6708S	X8 PCI Express Slot Interposer Includes: Statement of Compliance, Velcro Cable Managers, Probe Instruction Manual
P6716S	X16 PCI Express Slot Interposer Includes: Statement of Compliance, Velcro Cable Managers, Probe Instruction Manual
P6701SD	X1 PCI Express Differential Solder-down Probe Includes: Statement of Compliance, Velcro Cable Managers, Probe Instruction Manual

Models	Description
P6810	34-channel General-purpose Probe with Differential Clock, Differential Data, and Accessories Opt. DL: Differential Flying Lead Set (196-3471-xx)
P6860	34-channel High-density Compression Probe, with Differential Clock, Single-ended Data, and Accessories
P6864	17-channel (optimized for quarter-channel mode) High-density Compression Probe, with Differential Clock, Single-ended Data, and Accessories
P6880	34-channel High-density Compression Probe with Differential Clock, Differential Data, and Accessories
P6960	34-channel Single-ended High-density Compression Probe with D-Max™ Probing Technology, with Differential Clock, Single-ended Data, and Accessories Opt 01: 34-channel General-purpose Flying Lead Set (196-3494-xx)
P6962	34-channel (optimized for half-channel mode) Single-ended High-density Compression Probe with D-Max® Probing Technology with Differential Clock, Single-ended Data, and Accessories
P6962DBL	34-channel (optimized for half-channel mode) Single-ended High-density Compression Probe with D-Max® Probing Technology with Differential Clock, Single-ended Data, and Accessories
P6964	34-channel (optimized for quarter-channel mode) Single-ended High-density Compression Probe with D-Max® Probing Technology with Differential Clock, Single-ended Data, and Accessories
P6980	34-channel Differential High-density Compression Probe with D-Max® Probing Technology, with Differential Clock, Differential Data, and Accessories
P6982	17-channel (optimized for half-channel mode) Differential High-density Compression Probe with D-Max® Probing Technology, with Differential Clock, Differential Data, and Accessories

Language Options

Option	Description
Opt. L0	English Manuals
Opt. L99	No Manuals

Service Options

Please refer to the Service section at the rear of this document for information on Calibration and Repair options for these probes.

Accessories**P64xx Accessories**

Description	P6410		P6419*4		P6434		P6450	
	Qty. per Probe	Part Number	Qty. per Probe	Part Number	Qty. per Probe	Part Number	Qty. per Probe	Part Number
Nut Bar (used on <0.093 in. thick PCB), Bag of 2	—	—	1	020-2453-xx	—	—	—	—
Elastomer Holder Assembly, Thin (used on <0.093 in. thick PCB), Bag of 2	—	—	1	020-2451-xx	—	—	—	—
Elastomer Holder Assembly, Thick (used on >0.093 in. thick PCB), Bag of 2	—	—	1	020-2452-xx	—	—	—	—
Probe Retention Kit for D-Max Probing Technology	—	—	—	—	—	—	1	020-2908-xx
Sheet of Probe Labels	1	334-9979-xx	1	335-1007-xx	1	334-9381-xx	1	335-1990-xx
1 Latch Housing Assembly, Edge-mount	—	—	—	—	1	105-1088-xx	—	—
1 Latch Housing Assembly, Vertical	—	—	—	—	1	105-1089-xx	—	—
High-resistance Adapter for use with General-purpose Probes*5	1	TLAHRA	—	—	—	—	—	—
Optional								
One-to-Two Adapter	1 each	013-0280-xx	—	—	—	—	—	—
1 each – AMP Mictor Connector, Surface-mount	—	—	—	—	1	131-6134-xx	—	—
21 each – AMP Mictor Connector, Surface-mount	—	—	—	—	1	020-2228-xx	—	—
Mictor-on-PCB to P6419 Probe Adapter	—	—	1	020-2457-xx	—	—	—	—
Compression-on-PCB to Mictor Adapter, 17 channel	—	—	1	020-2455-xx	—	—	—	—
Compression-on-PCB to Mictor Adapter, 34 channel	—	—	1	020-2456-xx	1	020-2456-xx	—	—

*4 Recommend PEM KFS-256 or equivalent for >0.093 in. thick PCB.

*5 Provides 1 M Ω input resistance for use in low-power applications.

P68xx Standard Accessories

Description	P6810		P6860*4		P6864*4		P6880*4	
	Qty. per Probe	Part Number	Qty. per Probe	Part Number	Qty. per Probe	Part Number	Qty. per Probe	Part Number
Podlet Holders, Bag of 4	1	352-1097-xx	—	—	—	—	—	—
1-ch Leadset, Single-ended and Differential	2	196-3471-xx	—	—	—	—	—	—
8-ch Leadset, Single-ended	4	196-3470-xx	—	—	—	—	—	—
SMT KlipChip Grabber Tips, Bag of 20	2	SMG50	—	—	—	—	—	—
Nut Bar (used on <0.093 in. thick PCB)	—	—	2	220-0255-xx	1	220-0255-xx	4	220-0255-xx
Elastomer Holder Assembly, Thin (used on <0.093 in. thick PCB), Bag of 2	—	—	1	020-2451-xx	1	020-2451-xx	2	020-2451-xx
Elastomer Holder Assembly, Thick (used on >0.093 in. thick PCB), Bag of 2	—	—	1	020-2452-xx	1	020-2452-xx	2	020-2452-xx
Sheet of Probe Labels	1	335-0345-xx	1	335-0346-xx	1	335-1017-xx	1	335-0697-xx

*4 Recommend PEM KFS-256 or equivalent for >0.093 in. thick PCB.

P68xx Optional Accessories

Order Number	Description
TLAHR	High-resistance Adapter (18 channels) for P6810
020-2457-xx	Mictor-on-PCB to P6860 Probe Adapter
020-2453-xx	Nut Bar for Thin Elastomer Holder Assembly (Bag of 2)

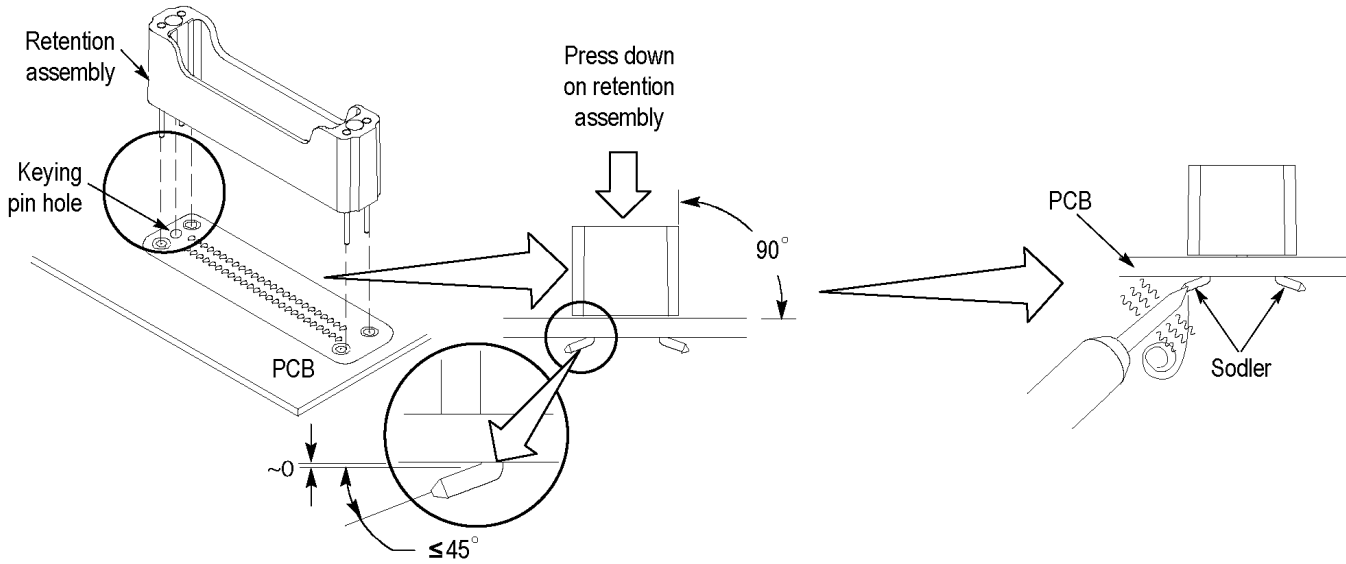

P69xx Probe Retention Kit

P69xx Standard Accessories

Description	P6960		P6962 / P6964		P6962DBL		P6980		P6982	
	Qty. per Probe	Part Number	Qty. per Probe	Part Number	Qty. per Probe	Part Number	Qty. per Probe	Part Number	Qty. per Probe	Part Number
Sheet of Probe Labels	1	335-1208-xx	1	P6962: 335-1772-xx P6964: 335-1315-xx	1	335-1956-xx	1	335-1209-xx	1	335-1313-xx
P69xx Probe Retention Kit	1	020-2908-xx	1	020-2908-xx	1	020-2908-xx	2	020-2908-xx	1	020-2908-xx
Probe Adjustment Tool	1	003-1890-xx	1	003-1890-xx	1	003-1890-xx	1	003-1890-xx	1	003-1890-xx
Velcro Cable Manager (Bag of 2)	1	346-0300-xx	1	346-0300-xx	1	346-0300-xx	1	346-0300-xx	1	346-0300-xx

P69xx Optional Accessories

Order Number	Description
020-2539-xx	P69xx Probe Mounting Posts

P67xx Mid-bus Standard Accessories

Description	P6708		P6716	
	Qty. per Probe	Part Number	Qty. per Probe	Part Number
Retention Mechanisms	2	020-2785-xx	2	020-2784-xx
Sheet of Probe Labels	1	335-1729-xx	1	335-1728-xx
Probe Adjustment Tool	1	003-1890-xx	1	003-1890-xx
Velcro Cable Manager (Bag of 2)	1	346-0300-xx	1	346-0300-xx

P6701SD Solder-down Standard Accessories

Description	Qty. per Probe	Part Number
TriMode™ Long Reach Solder Tip	1	P75TLRST
Storage Case	1	016-2009-xx
Solder Tip Tape (Strip of 10)	1	006-8237-xx
1 – .004 wire / 1 – .008 wire / 1 – SAC305 Solder (Package of 3 bobbins)	1	020-2754-xx
Hook and Loop fastening straps and dots	1	016-1953-xx
Installation Sheet	1	071-2503-xx

P6701SD Solder-down Required Accessories

Description	Qty.*6	Part Number
Power Adapter	1	870-0192-xx

*6 See Solder-down Probe Configuration for Required Quantities.

P6701SD Solder-down Optional Accessories

Description	Qty.	Part Number
Bullet Removal Tool	1	003-1896-xx
Replacement Bullet Contacts	Pack of 4	003-0359-xx

Service Options

Customers who choose a Tektronix product receive a support partnership focused on making the deployment and operation of their products successful. Tektronix support teams are committed to providing rapid response. A broad range of flexible services is available at the time of product purchase to meet customer service needs.

Option	Description
P6410 C3 P6450 C3	Calibration Service, 3 years
P6410 C5 P6450 C5	Calibration Service, 5 years
P6410 R3 P6450 R3	Repair Service, 3 years (incl. warranty)
P6410 R5 P6450 R5	Repair Service, 5 years (incl. warranty)
P6410 CA1 P6450 CA1	Provides a single calibration event or coverage for the designated calibration interval, whichever comes first
P6410-R1PW P6450-R1PW	Repair Service Coverage, 1-year post warranty
P6410-R2PW P6450-R2PW	Repair Service Coverage, 2-years post warranty
P6410-R3DW P6450-R3DW	Repair Service Coverage, 3 years (incl. product warranty period). 3-year period starts at time of instrument purchase
P6410-R5DW P6450-R5DW	Repair Service Coverage, 5 years (incl. product warranty period). 5-year period starts at time of instrument purchase

The following service options are offered for the TLA logic analyzer probes.

Option	P68xx/P69xx Probes	P67xx Probes
Opt. CA1 provides a single calibration event or coverage for the designated calibration interval, whichever comes first	X	X
Opt. C3 Calibration Service, 3 Years	X	X
Opt. C5 Calibration Service, 5 Years	X	X
Opt. D1 Calibration Data Report		
Opt. D3 Calibration Data Report, 3 Years (with Opt. C3)		
Opt. D5 Calibration Data Report, 5 Years (with Opt. C5)		
Opt. R3 Repair Service, 3 Years	X	X
Opt. R5 Repair Service, 5 Years	X	X
Opt. S1 On-site service, 1 Year		
Opt. S3 On-site service, 3 Years (with R or C options)		
Opt. R1PW Repair Service Coverage, 1-year Post Warranty	X (Not P6982)	X
Opt. R2PW Repair Service Coverage, 2-years Post Warranty	X (Not P6982)	X
Opt. R3DW Repair Service Coverage, 3 Years (includes product warranty period). 3-year period starts at time of instrument purchase	X (Not P6982)	X
Opt. R5DW Repair Service Coverage, 5 Years (includes product warranty period). 5-year period starts at time of instrument purchase	X (Not P6982)	X



Product(s) are manufactured in ISO registered facilities.

Contact Tektronix:

ASEAN / Australasia (65) 6356 3900
Austria +41 52 675 3777
Balkans, Israel, South Africa and other ISE Countries +41 52 675 3777
Belgium 07 81 60166
Brazil +55 (11) 3759-7627
Canada 1 (800) 661-5625
Central East Europe, Ukraine, and the Baltics +41 52 675 3777
Central Europe & Greece +41 52 675 3777
Denmark +45 80 88 1401
Finland +41 52 675 3777
France +33 (0) 1 69 86 81 81
Germany +49 (221) 94 77 400
Hong Kong (852) 2585-6688
India (91) 80-42922600
Italy +39 (02) 25086 1
Japan 81 (3) 6714-3010
Luxembourg +44 (0) 1344 392400
Mexico, Central/South America & Caribbean 52 (55) 54247900
Middle East, Asia, and North Africa +41 52 675 3777
The Netherlands 090 02 021797
Norway 800 16098
People's Republic of China 86 (10) 6235 1230
Poland +41 52 675 3777
Portugal 80 08 12370
Republic of Korea 82 (2) 6917-5000
Russia & CIS +7 (495) 7484900
South Africa +27 11 206 8360
Spain (+34) 901 988 054
Sweden 020 08 80371
Switzerland +41 52 675 3777
Taiwan 886 (2) 2722-9622
United Kingdom & Ireland +44 (0) 1344 392400
USA 1 (800) 426-2200

For other areas contact Tektronix, Inc at: 1 (503) 627-7111

Updated 5 August 2009

For Further Information. Tektronix maintains a comprehensive, constantly expanding collection of application notes, technical briefs and other resources to help engineers working on the cutting edge of technology. Please visit www.tektronix.com



Copyright © Tektronix, Inc. All rights reserved. Tektronix products are covered by U.S. and foreign patents, issued and pending. Information in this publication supersedes that in all previously published material. Specification and price change privileges reserved. TEKTRONIX and TEK are registered trademarks of Tektronix, Inc. All other trade names referenced are the service marks, trademarks, or registered trademarks of their respective companies.

24 Mar 2010

52W-17703-4

