

User's Guide

Publication number 01156-97002
September 2005

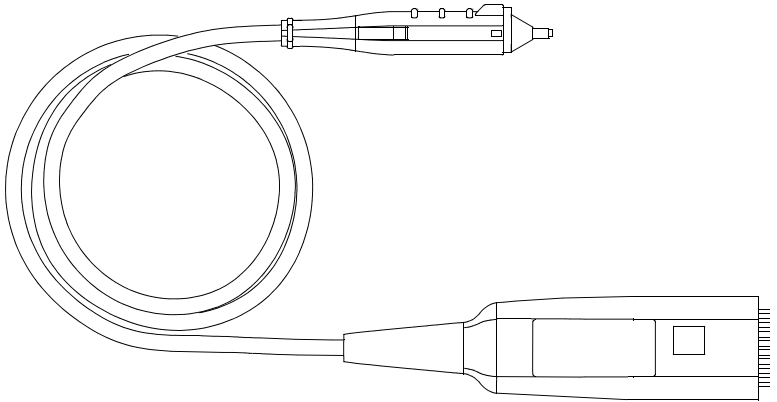

For Safety and Regulatory information, see the pages at the back of this guide.
© Copyright Agilent Technologies 2001-2002, 2005
All Rights Reserved.

1156A 1.5 GHz Active Probe

In This Book

This guide provides user and service information for the 1156A 1.5 GHz Active Probe.

Chapter 1 gives you general information such as inspection, cleaning, accessories supplied, and specifications and characteristics of the probe.

Chapter 2 shows you how to operate the probe and gives you information about some important aspects of probing and how to get the best results with your probe.

Chapter 3 provides service information.

Contents

1 General Information

To inspect the probe	7
Accessories Supplied	8
Replaceable Parts and Additional Accessories	10
Characteristics and Specifications	11
General Characteristics	12
To use the probe	14
Probe handling considerations	14
Cleaning the probe	14
Using Probe Accessories	15
To connect the probe	16



2 Operating the Probe

110 Ohm Resistive Signal Pin (Green) and Solderable Ground Socket	21
130 Ohm Resistive Signal Pin (Orange) and Ground Blade Assembly	25
5 cm Resistive Signal Leads and Solderable SMT or Solderable Through-hole Ground Pin	29
Socket-end 10 cm Resistive Signal Lead and Solderable SMT or Solderable Through-hole Ground Pin	33
Micro Clip	37
Undamped Accessories	37

3 Service

Service Strategy	42
To return the probe to Agilent Technologies for service	43
Troubleshooting	44
Failure Symptoms	44
Probe Calibration Fails	44
Incorrect High Frequency Response	44
Incorrect Low Frequency Response (pulse flatness)	45
Incorrect Input Resistance	45
Incorrect Offset	45
Offset Will Not Zero	45
Verifying probe input resistance	46

1156A 1.5 GHz Active Probe

The 1156A 1.5 GHz Active Probe is a probe solution for high-frequency applications. This probe is compatible with the AutoProbe Interface which completely configures the Infiniium series of oscilloscopes for the probe.

To inspect the probe

- ❑ Inspect the shipping container for damage.

Keep a damaged shipping container or cushioning material until the contents of the shipment have been checked for completeness and the instrument has been checked mechanically and electrically.

- ❑ Check the accessories.

Accessories supplied with the instrument are listed in "Accessories Supplied" in table 1-1 later in this chapter.

- If the contents are incomplete or damaged notify your Agilent Technologies Sales Office.

- ❑ Inspect the probe.

- If there is mechanical damage or defect, or if the probe does not operate properly or pass calibration tests, notify your Agilent Technologies Sales Office.
- If the shipping container is damaged, or the cushioning materials show signs of stress, notify the carrier as well as your Agilent Technologies Sales Office. Keep the shipping materials for the carrier's inspection. The Agilent Technologies Office will arrange for repair or replacement at Agilent Technologies' option without waiting for claim settlement.

Figure 1-1

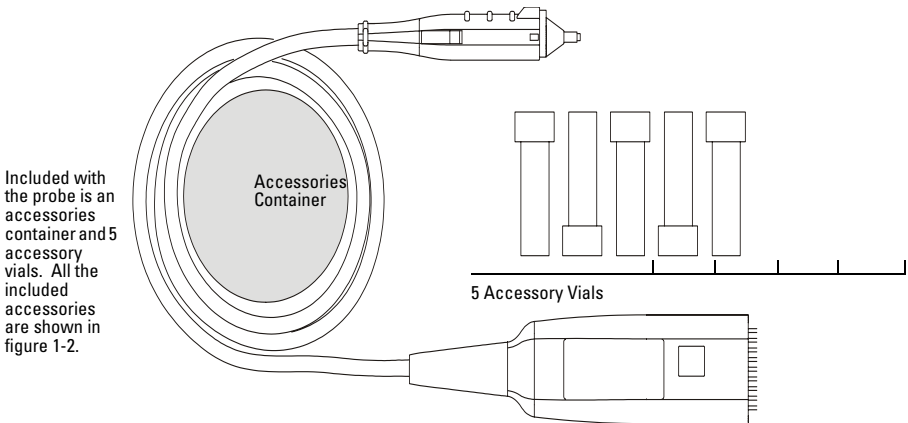

Included with the probe is an accessories container and 5 accessory vials. All the included accessories are shown in figure 1-2.

1156A Active Probe

01158e03.cdr

Accessories Supplied

The following figure and table show the accessories supplied with the 1156A Active Probe.

Figure 1-2

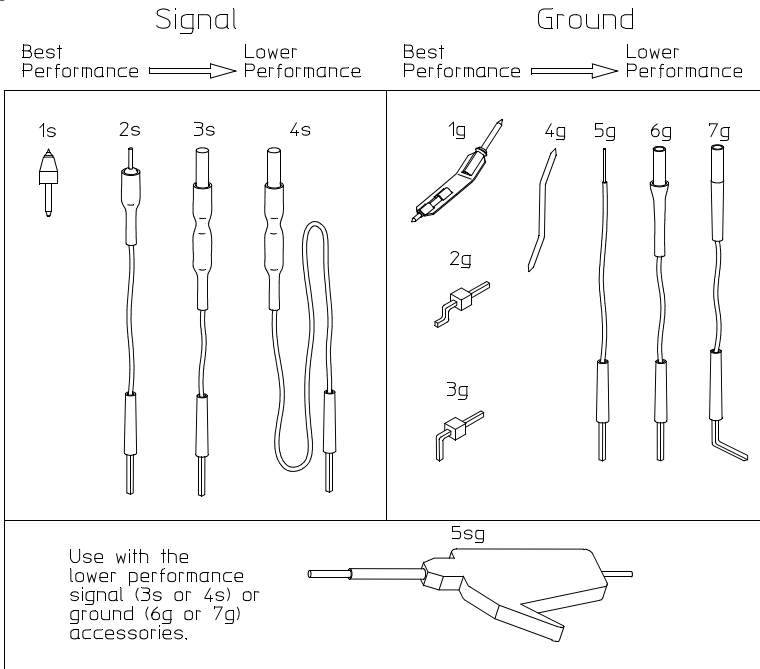

Table 1-1

Accessories Supplied

Item	Description	Qty	Agilent Part Number
1s	130 Ω resistive signal pin (orange)	12	01156-27616
2s	Solderable-tip 5 cm resistive signal lead	2	01156-82106
3s	Socket-end 5 cm resistive signal lead	2	01156-82105
4s	Socket-end 10 cm resistive signal lead	2	01156-82108
5sg	Micro clip	2	5063-2180
1g	Ground blade assembly	12	01156-23701
2g	Solderable SMT ground pin	12	1253-5054
3g	Solderable through-hole ground pin	12	1252-7150
4g	Offset ground pin	12	01156-27606
5g	Solderable-tip 5 cm ground lead	2	01156-82107
6g	Socket-end 5 cm ground lead	2	01156-82103
7g	Socket-end 5 cm, 90° pin ground lead	2	01156-82104

Replaceable Parts and Additional Accessories

Table 1-2

Replaceable Parts and Additional Accessories

Agilent Part Number	Description	Qty
E2638A	Solderable-tip 5 cm resistive signal lead	10
	Solderable-tip 5 cm ground lead	3
E2639A	Micro clip	4
E2640A	130 Ω resistive signal pin (orange)	8
E2641A	Ground blade assembly	8
E2637A	Precision Measurement Kit includes 2 solderable ground sockets and 2 110 Ω resistive signal pins (green)	1
E2654A	EZ-Probe [®] positioner	1

Characteristics and Specifications

The following characteristics are typical for the active probe.

Table 1-3

Characteristics	
Bandwidth¹ (-3 dB)	> 1.5 GHz
System bandwidth (-3 dB)	1156A with 54832B/D or 54835A scope: 1 GHz
Rise and Fall Time (10% to 90%)	< 233 ps calculated from $t_r = \frac{0.35}{\text{Bandwidth}}$
Input Capacitance	0.8 pF
Input Resistance¹	100 k Ω \pm 1%
Flatness, Swept Response	0.2 dB, 100 kHz to 100 MHz 0.4 dB, 100 MHz to 1.5 GHz
Flatness, Step Response	15% overshoot, 35 ps input edge 10% overshoot: 75 ps input edge; 2%: 1 ns after edge
Dynamic Range²	> 5.0 V peak-to-peak
DC Attenuation	10:1
Offset error referred to input	< \pm 30 mV
Offset Range	\pm 15.0 V
Offset Gain Accuracy	< \pm 3% of setting
Noise referred to input	3.0 mVrms
Propagation Delay	5.5 ns
Maximum Input Voltage³	40 V peak, CAT I
ESD Tolerance	> 5 kV from 100 pF, 300 Ω HBM
Temperature Drift	Offset: < 1.0 mV/ $^{\circ}$ C Attenuation: < 0.1 %/ $^{\circ}$ C



1 Denotes warranted specifications, all others are typical.

2 For waveforms with edges > 3 ns, the dynamic range is > 12.0 Vpeak-to-peak

3 Installation category (overvoltage category) I: Signal level, special equipment, or parts of equipment, telecommunication, electronic, etc., with smaller transient overvoltages than installation category (overvoltage category) II.

General Characteristics

The following general characteristics apply to the active probe.

Table 1-4

General Characteristics

Environmental Conditions

	Operating	Non-operating
Temperature	0 °C to +55 °C	-40 °C to +70 °C
Altitude	4000 meter (13,000 ft)	
Humidity	up to 95% relative humidity (non-condensing) at +40 °C	up to 90% relative humidity at +65 °C
Power Requirements	+12 Vdc @ 3 mA typical +5 Vdc @ 35 mA typical -5 Vdc @ 37 mA typical 0.4 W	(voltages supplied by AutoProbe Interface)
Weight	approximately 0.69 kg	
Dimensions	Refer to the outline in figure 1-3.	
Pollution degree 2	Normally only non-conductive pollution occurs. Occasionally, however, a temporary conductivity caused by condensation must be expected.	
Indoor use		

Figure 1-3

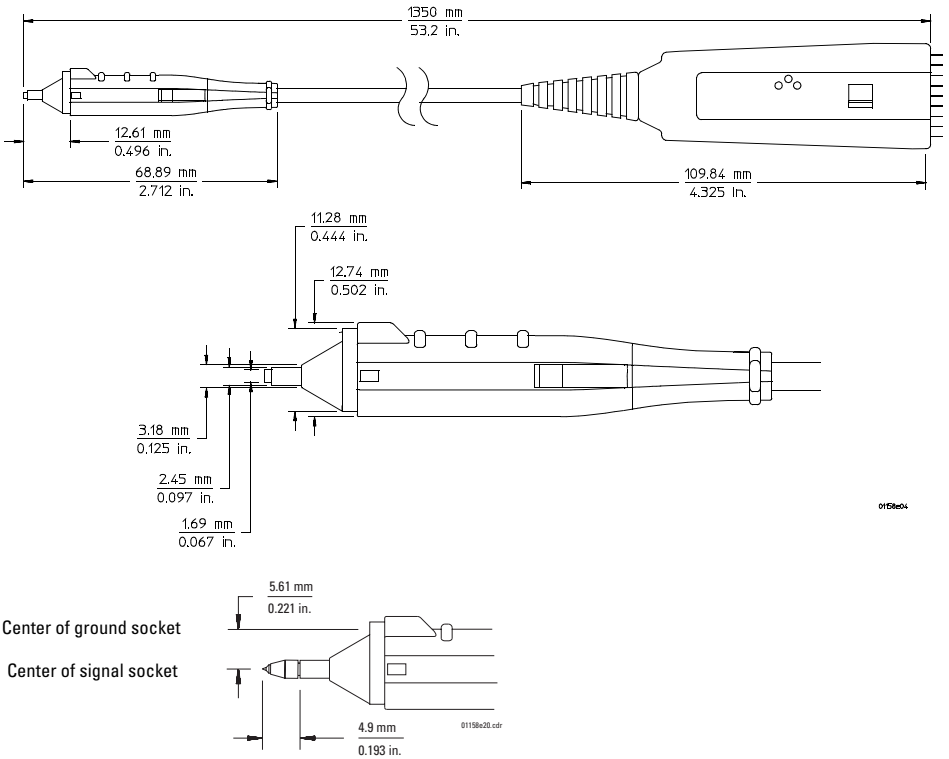

1156A Active Probe Dimensions

To use the probe

The Infiniium family of oscilloscopes provides both power and offset control to the 1156A active probe through the front panel connector. Probe offset is changed by adjusting the vertical offset control on the Infiniium oscilloscope. The control should be adjusted to center your waveform within the 5 volt peak-to-peak (12 volts peak-to-peak for slow waveforms) dynamic range of the probe.

Probe handling considerations

This probe has been designed to withstand a moderate amount of physical and electrical stress. However, with an active probe, the technologies necessary to achieve high performance do not allow the probe to be unbreakable. You should treat the probe with care. It can be damaged if excessive force is applied to the probe tip. This damage is considered to be abuse and will void the warranty when verified by Agilent Technologies service professionals.

- Exercise care to prevent the probe end from receiving mechanical shock.
 - Store the probe in a shock-resistant case such as the foam-lined shipping case which came with the probe.
-

Cleaning the probe

If the probe requires cleaning, disconnect it from the oscilloscope and clean it with a soft cloth dampened with a mild soap and water solution. Make sure the probe is completely dry before reconnecting it to the oscilloscope.

Using Probe Accessories

Before you can use the 1156A probe you must install the signal and ground accessories that you want to use. As an example, the following figure shows the installation of the 130 Ω resistive signal pin (orange) and the ground blade assembly into the probe.

Figure 1-4

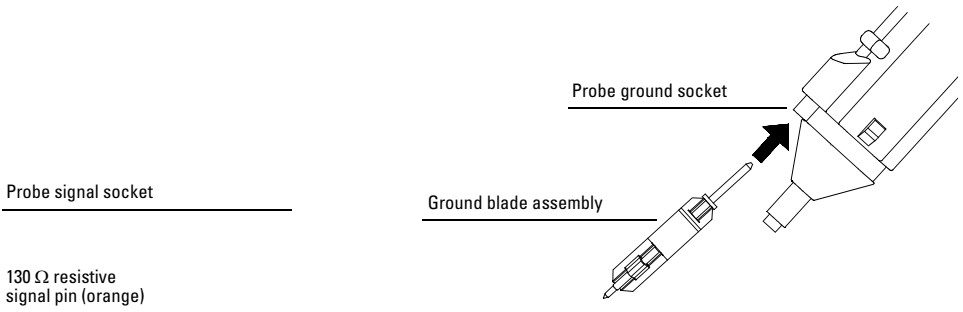

Installing the signal and ground pins

There are several probe accessories that can be attached to the 1156A probe which can make it easier to probe different types of circuits and circuit conditions. Each accessory has a different affect on the performance of the probe, as shown in chapter 2.

To connect the probe

- 1** Connect the probe output to the oscilloscope input.
- 2** Calibrate the oscilloscope and probe combination using the Infiniium probe calibration routine.

When the probe has been calibrated, the dc gain, offset zero, and offset gain will be calibrated. The degree of accuracy specified at the probe tip is dependent on the oscilloscope system specifications.

Operating the Probe

Introduction

The Agilent 1156A active probe comes with accessories that place a resistor as close as possible to the circuit being probed. The purpose of this resistor is to dampen the resonant circuit created when the probe tip makes physical contact with the circuit. The resonant circuit is made from the parasitics of the physical connection between the point being probed and the internal attenuator of the probe.

All probes suffer from the effects of this resonant circuit at the input of the probe. However, with lower bandwidth probes the resonant frequency is much higher than the bandwidth of the probe making this effect less noticeable.

The bandwidth of the 1156A active probe is higher than the resonant frequency of the physical connection to the probed circuit, even when using the smallest possible physical connection. Placing a resistor between the circuit being probed and the parasitics of the physical connection isolates the circuit being probed from this resonance. This allows the response of the probe (V_{out}/V_{in}) to be flat across the entire bandwidth of the probe.

It is important to understand that the resistor placed at the point being probed is part of the probe. The optimum value of this resistor depends on the geometry of the physical connection to the circuit being probed. The optimum value of resistance is used in each of the suggested configurations shown in table 2-1.

Table 2-1

Suggested Configurations and Characteristics

Configuration	Bandwidth	Rise time	Input C	Minimum Z_{in}
110 Ω Resistive Signal Pin (green) and Solderable Ground Socket	> 1.5 GHz	< 235 ps	0.9 pF	125 Ω
130 Ω Resistive Signal Pin (orange) and Ground Blade	1.7 GHz	205 ps	0.8 pF	165 Ω
5 cm Resistive Signal Leads and Solderable SMT or Through-hole Ground Pin	1.4 GHz	250 ps	1.2 pF	230 Ω
Socket-end 10 cm Resistive Signal Lead and Solderable SMT or Through-hole Ground Pin	850 MHz	410 ps	1.8 pF	275 Ω

Each suggested configuration is optimized for flattest response and highest input impedance. For response, this means that the waveform at the output of the probe will be as close as possible to the waveform at the input of the probe without introducing overshoot, ringing, or other unwanted perturbations. For input impedance, this means that the input impedance is as high as possible throughout the entire bandwidth of the probe, thus never resonating low due to

the parasitics of the physical connection. Even when using the socket-end 10 cm resistive signal lead, the response and input impedance of the probe are very well behaved.

Other signal lead lengths may be used with this probe but a resistance value needs to be determined from the following figure and a resistor of that value needs to be placed as close as possible to the point being probed.

Optimum Damping Resistor Value Versus Signal Lead Length

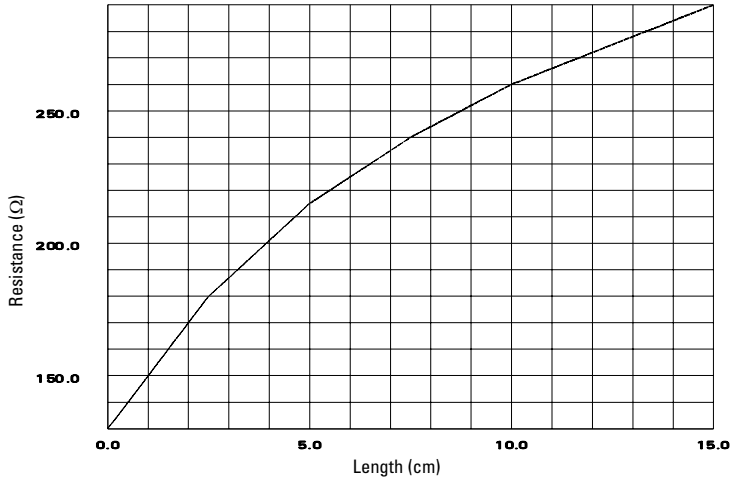

If a resistor is not used, the response of the probe will be very peaked at high frequencies. This will cause overshoot and ringing to be introduced in the step response of waveforms with fast rise times. Use of this probe without a resistor at the point being probed should be limited to measuring only waveforms with slower rise times.

When simulating circuits that include a load model for the probe, a simplified model of the probes input impedance can usually be used. The following figure and table contain the information for the simplified model of the probe. For more accurate load models, see the following sections.

Simplified probe input impedance model

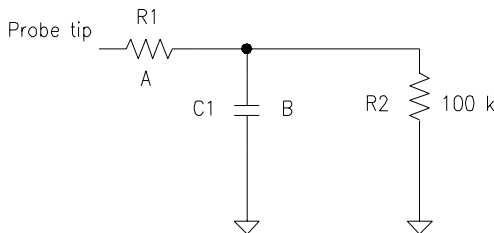

Table 2-2

Configuration	A	B
110 Ω Resistive Signal Pin (green) and Solderable Ground Socket	125 Ω	0.9 pF
130 Ω Resistive Signal Pin (orange) and Ground Blade	165 Ω	0.8 pF
5 cm Resistive Signal Leads and Solderable SMT or Through-hole Ground Pin	230 Ω	1.2 pF
Socket-end 10 cm Resistive Signal Lead and Solderable SMT or Through-hole Ground Pin	275 Ω	1.8 pF

Hints for connecting the probe to the point being measured

The suggested connection configurations are listed in order of performance. The smallest physical connection to the point being probed produces the highest bandwidth and the largest physical connection produces the lowest bandwidth. Although bandwidth and rise time degrades with the larger connections, each configuration is optimized to produce a flat response. None of the suggested configurations introduce overshoot or ringing into the waveform being measured.

110 Ohm Resistive Signal Pin (Green) and Solderable Ground Socket

This configuration produces the best probe performance of > 1.5 GHz or rise times of < 234 ps. The Ground Socket does not come with your probe but can be ordered from Agilent Technologies as part number E2637A.

The Ground Socket comes with a green-colored 110 Ω resistive signal pin which should be used only when using the Ground Socket.

110 Ω resistive signal pin (green) and solderable ground socket

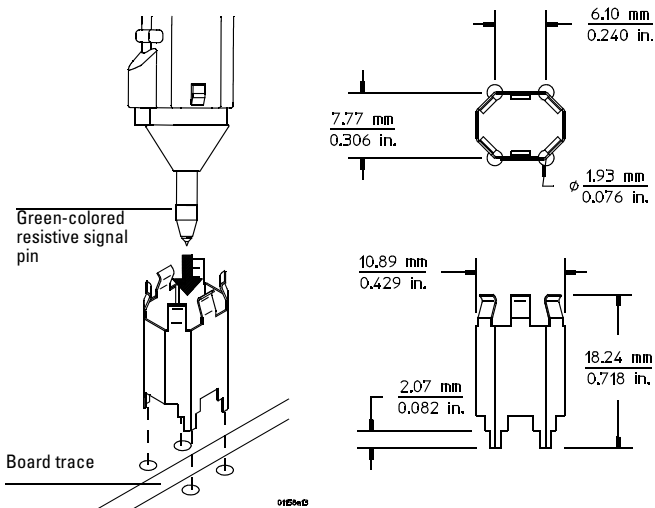

The 1156A probe has an input impedance which varies with frequency. The following schematic shows the circuit model for the input impedance of the probe when using the 110 Ω resistive signal pin (green) and solderable ground socket.

Operating the Probe

110 Ohm Resistive Signal Pin (Green) and Solderable Ground Socket

110 Ω Resistive Signal Pin (green) and Solderable Ground Socket Input Impedance Model

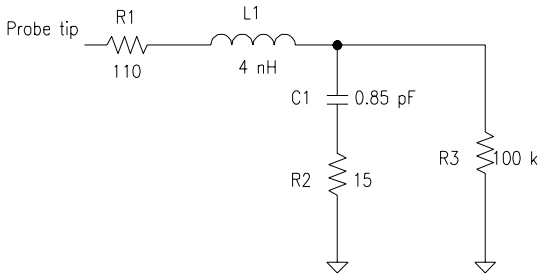

Magnitude Plot of Probe Input Impedance Versus Frequency

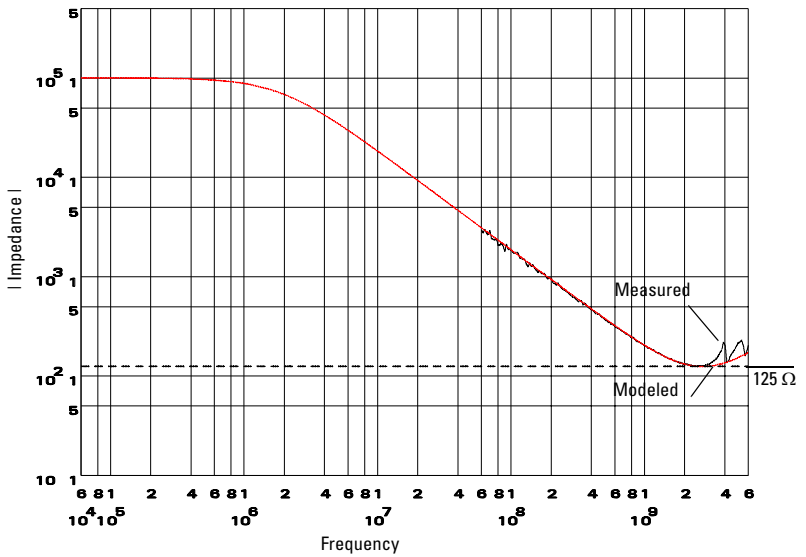

Graph of V_{in} to Probe and V_{out} of Probe with a $25\ \Omega$ Source

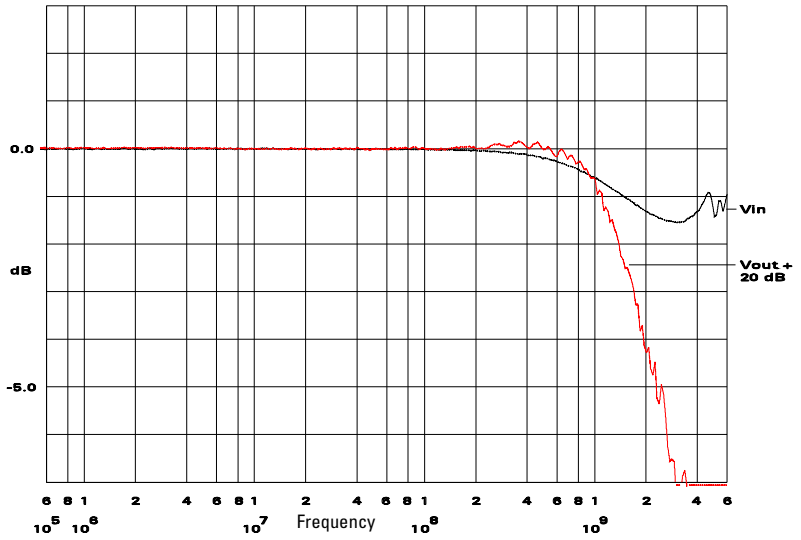

V_{out}/V_{in} Frequency Response

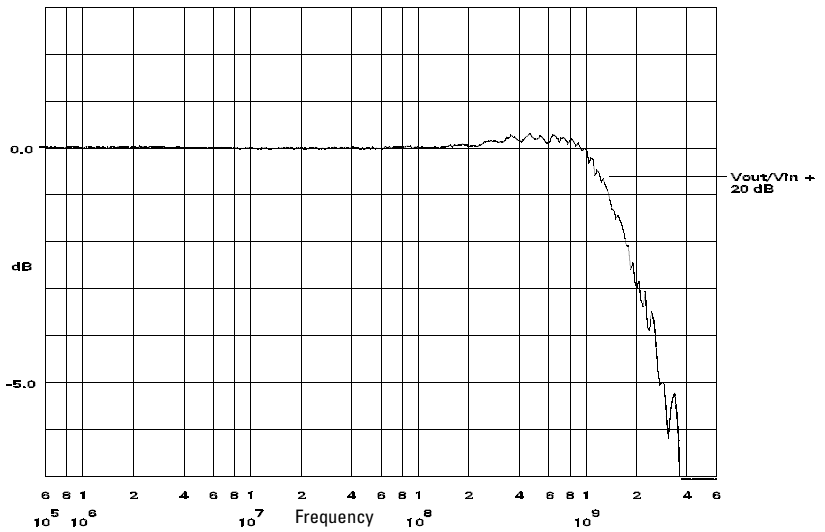

Operating the Probe 110 Ohm Resistive Signal Pin (Green) and Solderable Ground Socket

All probes have a loading effect on a circuit when they come in contact with the circuit. The following graph shows how the 110 Ω resistive signal pin (green) and solderable ground socket configuration affect a step from a 25 Ω source.

25 Ω Step Generator With and Without Probe Connected

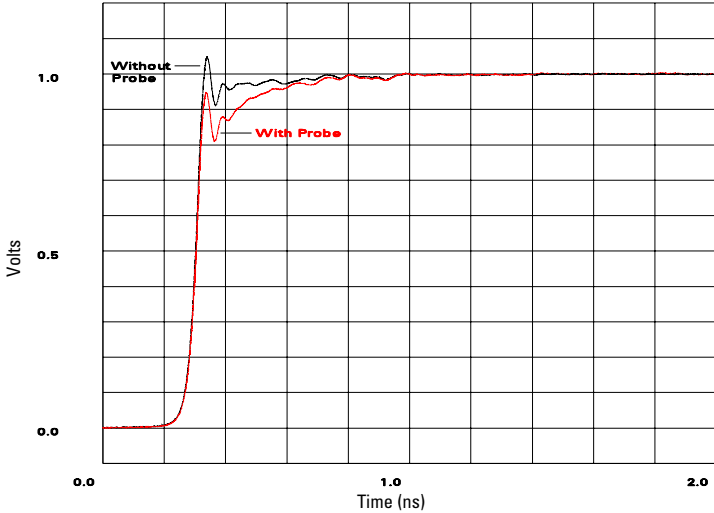

Vin and Vout of Probe

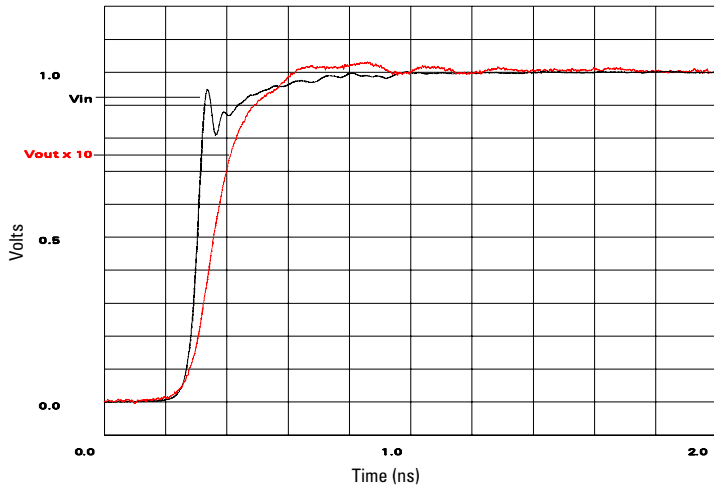

This is not the step response of the probe. The step response of a probe is the output of a probe while the input is a perfect step.

130 Ohm Resistive Signal Pin (Orange) and Ground Blade Assembly

This configuration is ideal for general purpose probing of circuit boards with high frequency analog or digital waveforms. This configuration produces a probing bandwidth of 1.7 GHz or rise time of 205 ps.

Probing using the 130 Ω resistive signal pin (orange) and ground blade assembly

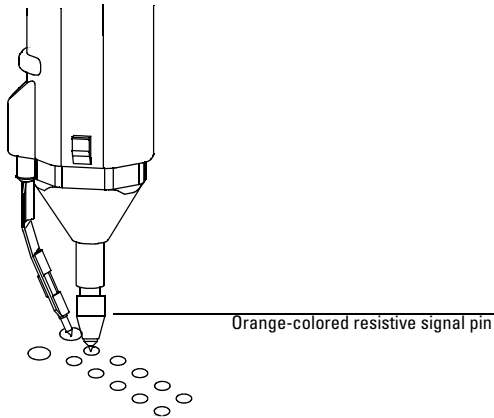

The 1156A probe has an input impedance which varies with frequency. The following schematic shows the circuit model for the input impedance of the probe when using the 130 Ω resistive signal pin (orange) and ground blade.

Operating the Probe

130 Ohm Resistive Signal Pin (Orange) and Ground Blade Assembly

130 Ω Resistive Signal Pin (Orange) and Ground Blade Input Impedance Model

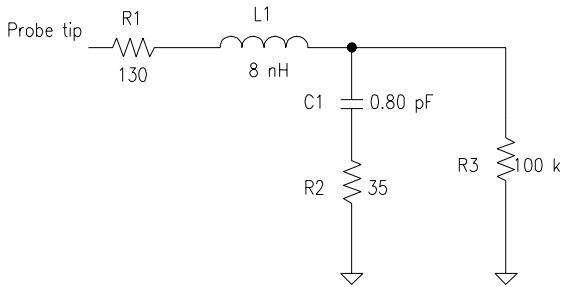

Magnitude Plot of Probe Input Impedance Versus Frequency

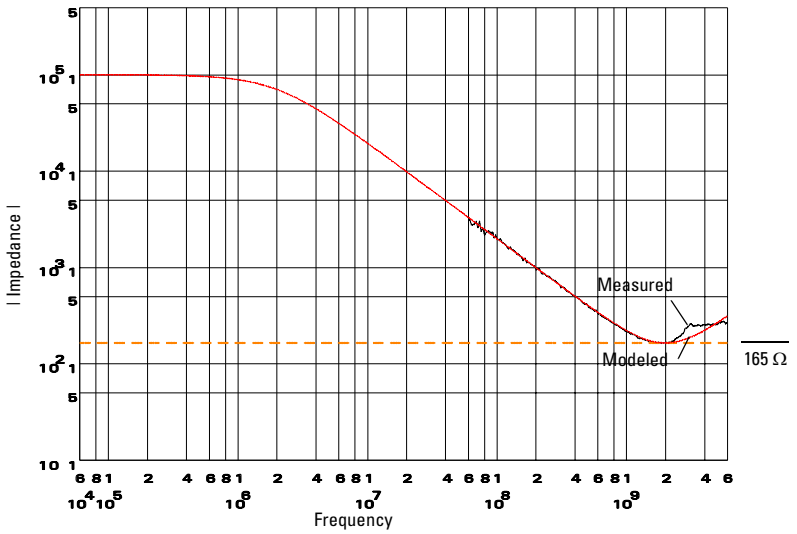

Graph of Vin to Probe and Vout of Probe with 25 Ω Source

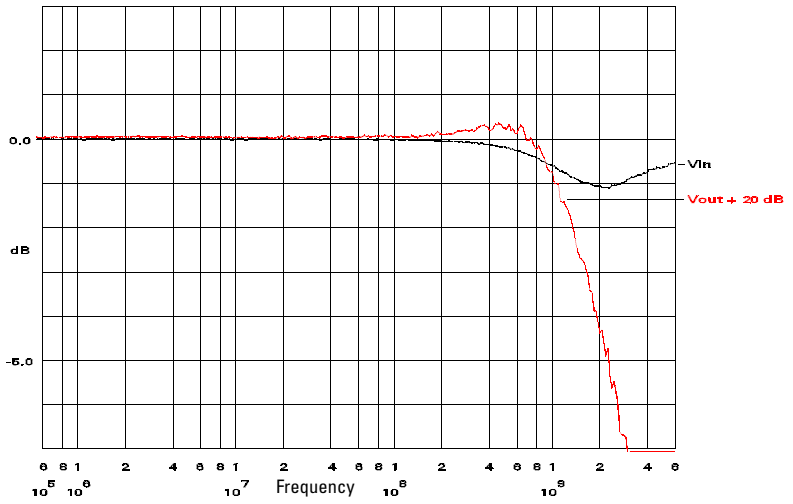

Vout/Vin Frequency Response

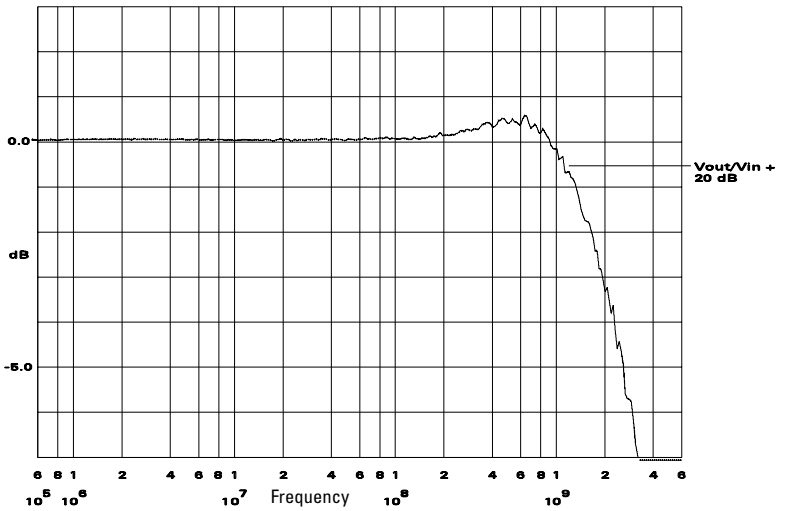

Operating the Probe

130 Ohm Resistive Signal Pin (Orange) and Ground Blade Assembly

All probes have a loading effect on a circuit when they come in contact with the circuit. The following graph shows how the 130 Ω resistive signal pin (orange) and ground blade assembly configuration affect a step from a 25 Ω source.

25 Ω Step Generator With and Without Probe Connected

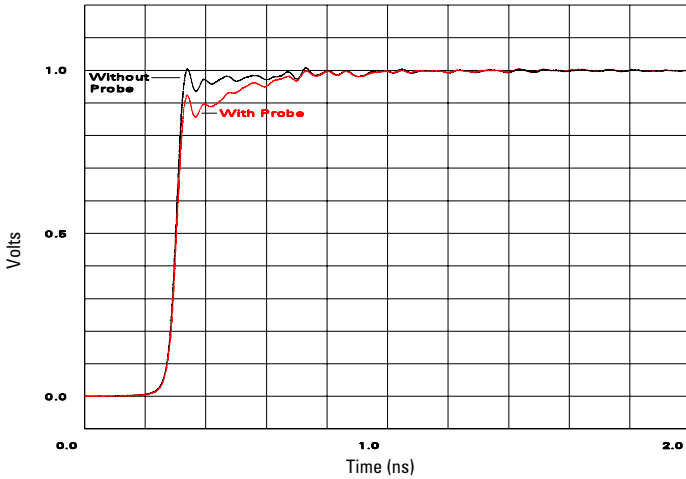

Vin and Vout of Probe

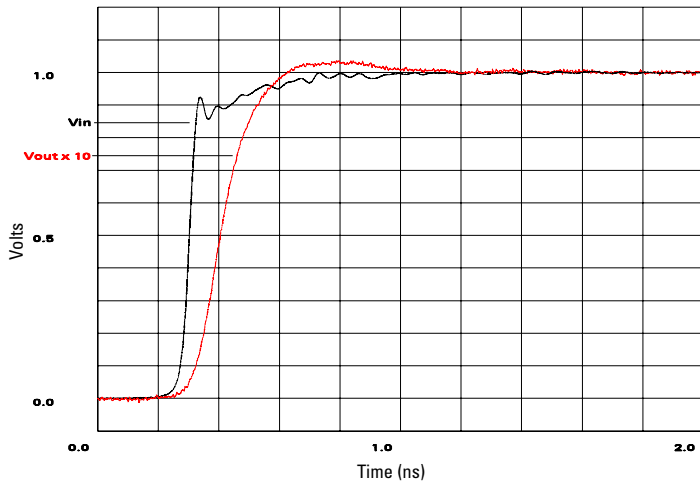

This is not the step response of the probe. The step response of a probe is the output of a probe while the input is a perfect step.

5 cm Resistive Signal Leads and Solderable SMT or Solderable Through-hole Ground Pin

These configurations are used to attach the probe to a round or a square pin of a header or to solder to the legs of a device under test. This configuration produces a probing bandwidth of 1.4 GHz or rise time of 250 ps.

Probing using the socket-end 5 cm resistive signal lead and solderable-tip 5 cm resistive signal lead

Socket-end 5 cm resistive
signal lead

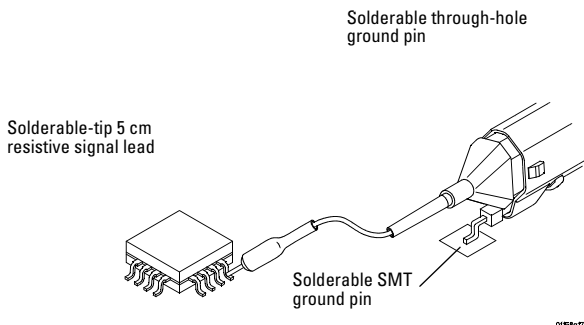

Any combination of 5 cm signal leads and ground pins can be used. Also, if you need to bend the signal pin where it enters the probe you can do this one time without breaking the pin. Be sure to remove the pin from the probe before you bend it.

When using this configuration, always make the ground connection as short as possible. Length in the ground connection makes the response of the probe dependent on the position of the probe, the position of the probe cable and many other variables, hence it makes the response of the probe unrepeatable. Also, keep the signal wire away from AC ground, other components, or your fingers. The damping resistor is optimized assuming that the signal wire is far from AC ground. The properly damped 5 cm wire with a very short ground connection produces a high quality, repeatable 1.4 GHz probe.

Operating the Probe

5 cm Resistive Signal Leads and Solderable SMT or Solderable Through-hole Ground Pin

The 1156A probe has an input impedance which varies with frequency. The following schematic shows the circuit model for the input impedance of the probe when using the 5 cm resistive signal lead and a solderable smt or through-hole ground lead.

5 cm Resistive Signal Lead Input Impedance Model

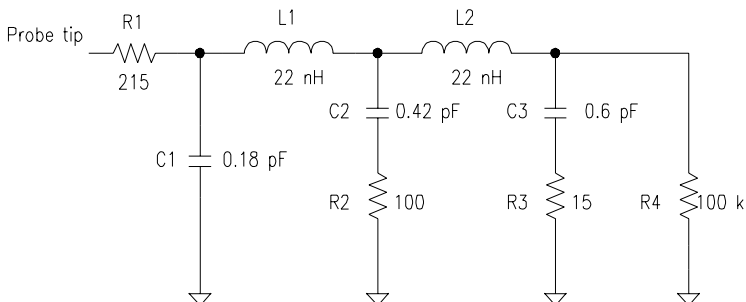

Magnitude Plot of Probe Input Impedance Versus Frequency

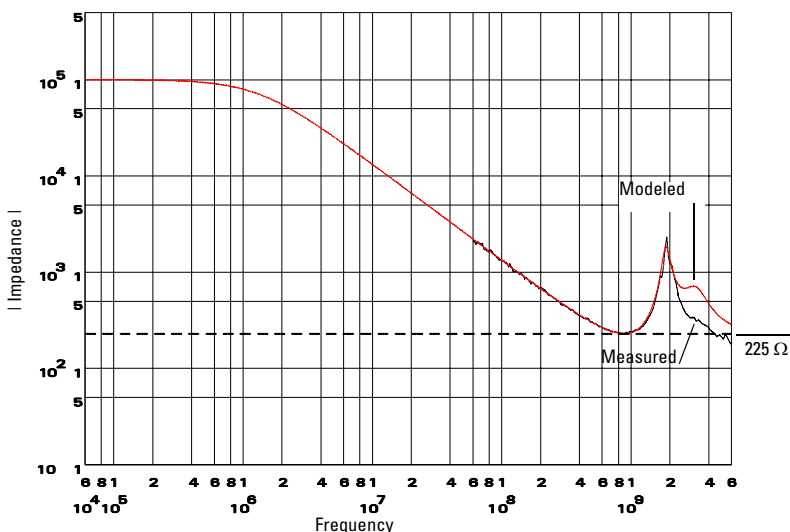

Graph of Vin to Probe and Vout of Probe with a 25 Ω Source

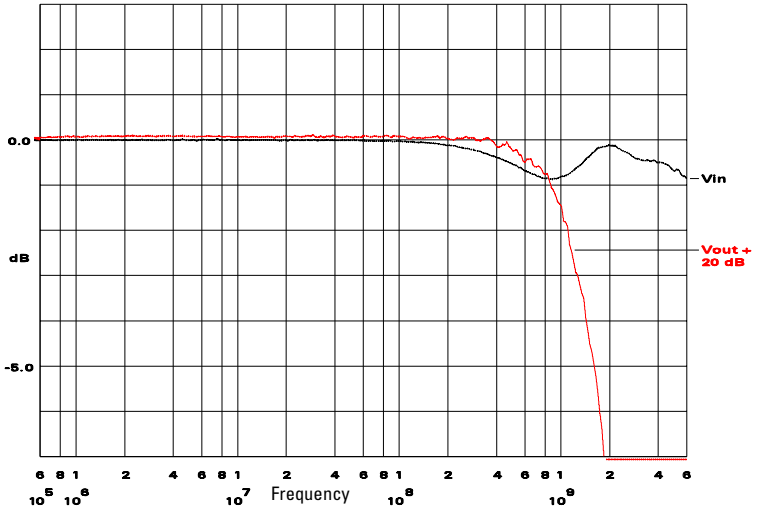

Vout/Vin Frequency Response

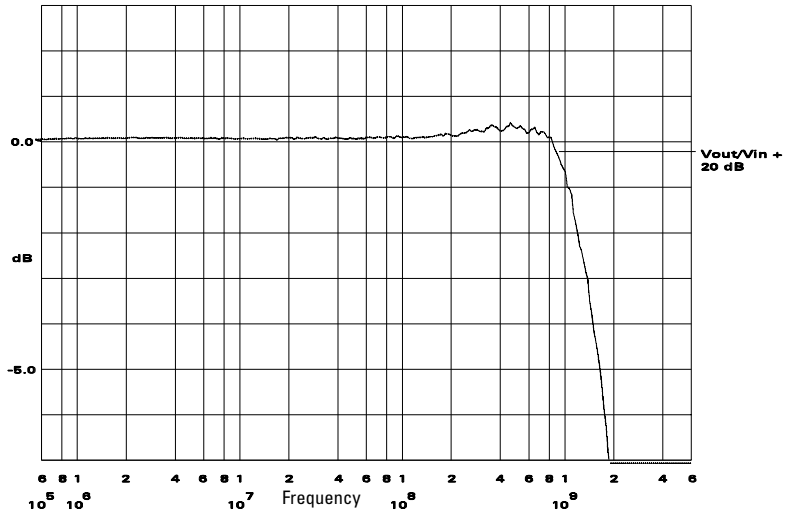

All probes have a loading effect on a circuit when they come in contact with the circuit. The following graph shows how the 5 cm resistive signal lead and a solderable smt or through-hole ground lead configuration affect a step from a 25 Ω source.

Operating the Probe

5 cm Resistive Signal Leads and Solderable SMT or Solderable Through-hole Ground Pin

25 Ω Step Generator With and Without Probe Connected

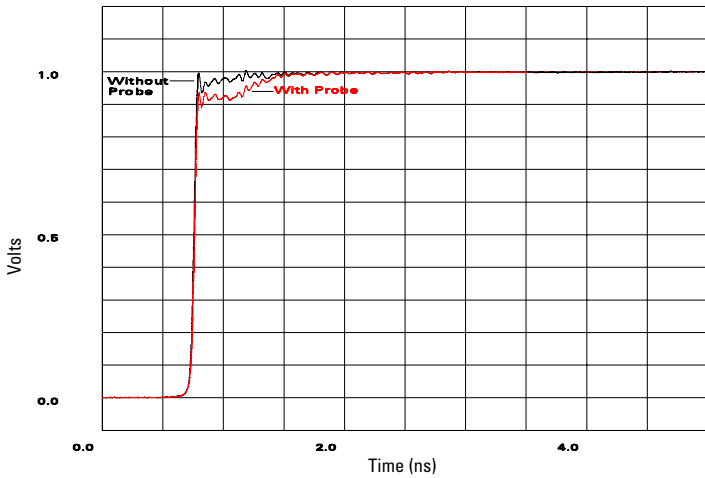

Vin and Vout of Probe

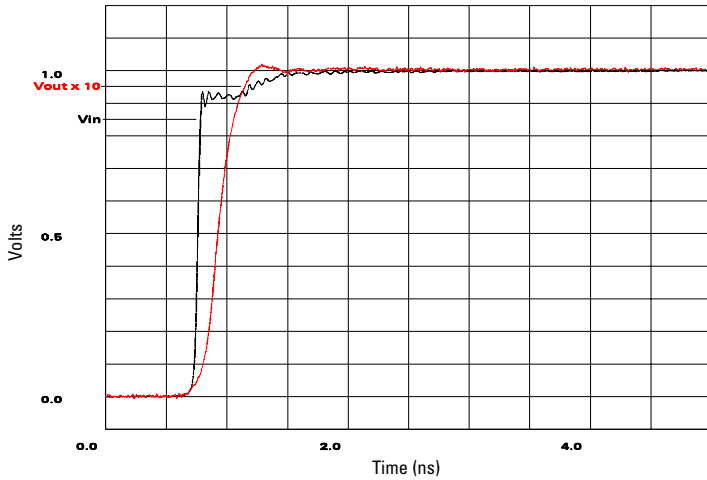

This is not the step response of the probe. The step response of a probe is the output of a probe while the input is a perfect step.

Socket-end 10 cm Resistive Signal Lead and Solderable SMT or Solderable Through-hole Ground Pin

This configuration is used to attach the probe to a round pin of a header, a square pin of a header, or a soldered in pin. This configuration produces a probing bandwidth of 850 MHz or rise time of 410 ps.

Figure 2-1

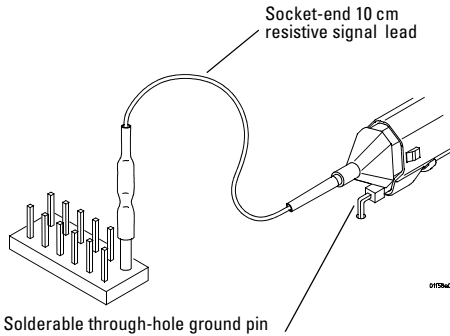

Probing using the socket-end 10 cm resistive signal lead

Either ground pin can be used. Also, if you need to bend the pin you can do this one time without breaking the signal pin where it enters the probe. Be sure to remove the pin from the probe before you bend it.

When using this configuration, always make the ground connection as short as possible. Length in the ground connection makes the response of the probe dependent on the position of the probe, the position of probe cable and many other variables, hence it makes the response of the probe unrepeatable. Also, keep the signal wire away from AC ground, other components, or your fingers. The damping resistor is optimized assuming that the signal wire is far from AC ground. The properly damped 10 cm wire with a very short ground connection produces a high quality, repeatable 850 MHz probe.

The 1156A probe has an input impedance which varies with frequency. The following schematic shows the circuit model for the input impedance of the probe when using the socket-end 10 cm resistive signal lead and a solderable smt or through-hole ground lead.

Operating the Probe

Socket-end 10 cm Resistive Signal Lead and Solderable SMT or Solderable Through-hole Ground Pin

10 cm Resistive Signal Lead Input Impedance Model

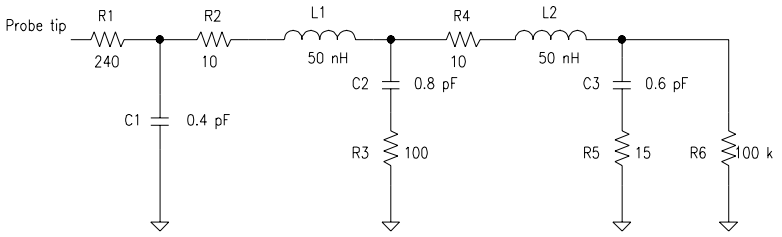

Magnitude Plot of Probe Input Impedance Versus Frequency

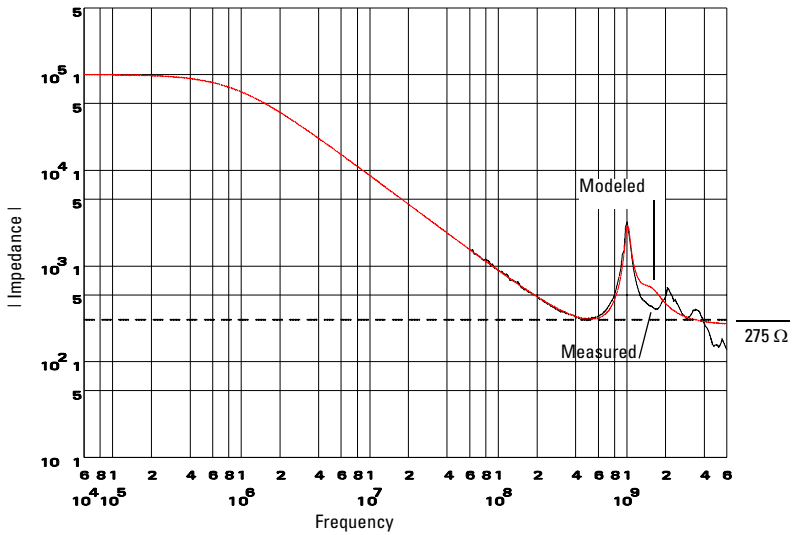

Graph of V_{in} to Probe and V_{out} of Probe with a $25\ \Omega$ Source

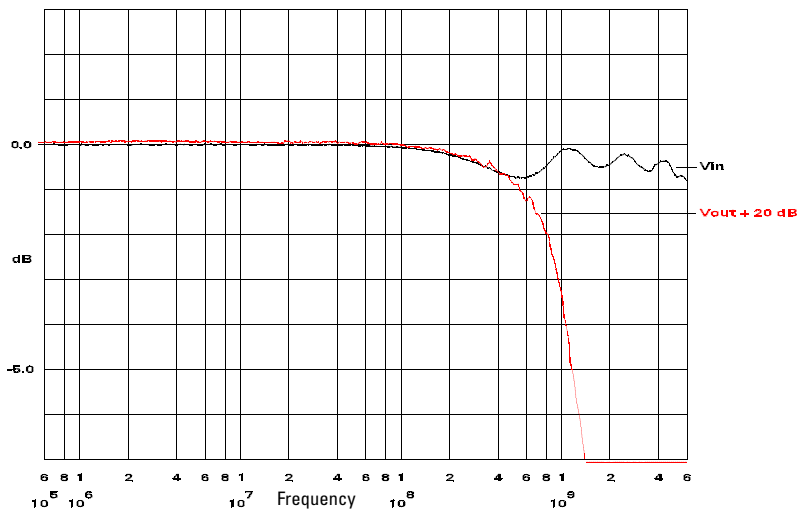

V_{out}/V_{in} Frequency Response

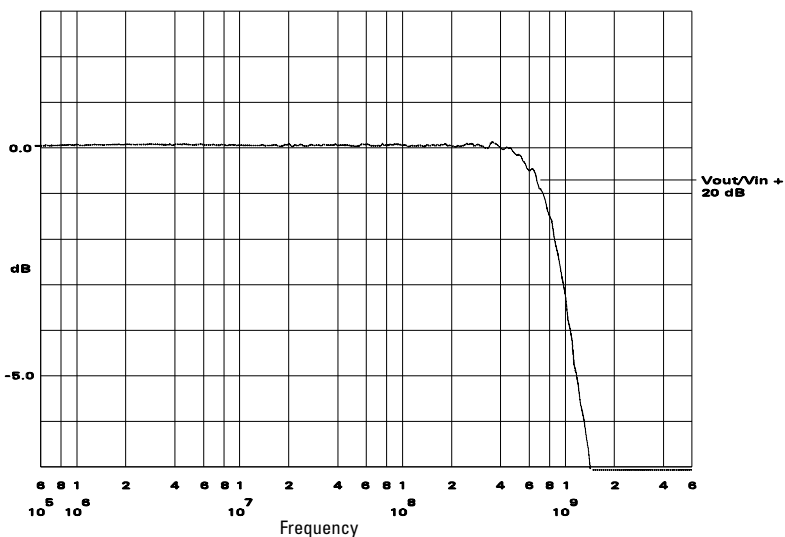

All probes have a loading effect on a circuit when they come in contact with the circuit. The following graph shows how the 10 cm resistive signal lead and a solderable smt or through-hole ground lead affect a step from a $25\ \Omega$ source.

Operating the Probe

Socket-end 10 cm Resistive Signal Lead and Solderable SMT or Solderable Through-hole Ground Pin

25 Ω Step Generator With and Without Probe Connected

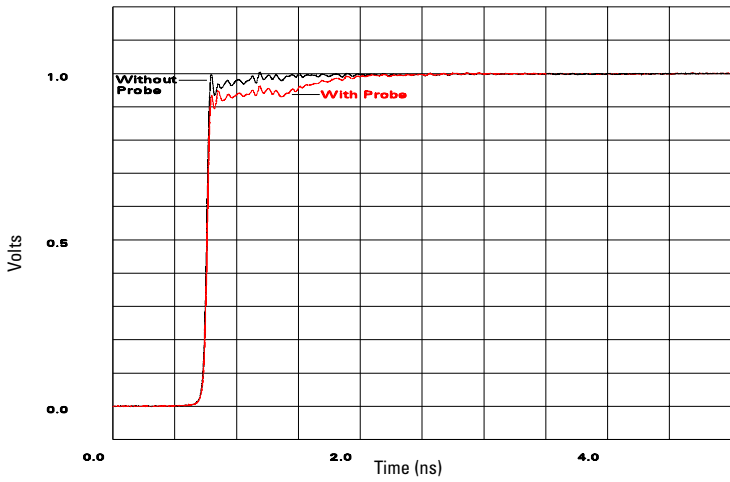

Vin and Vout of Probe

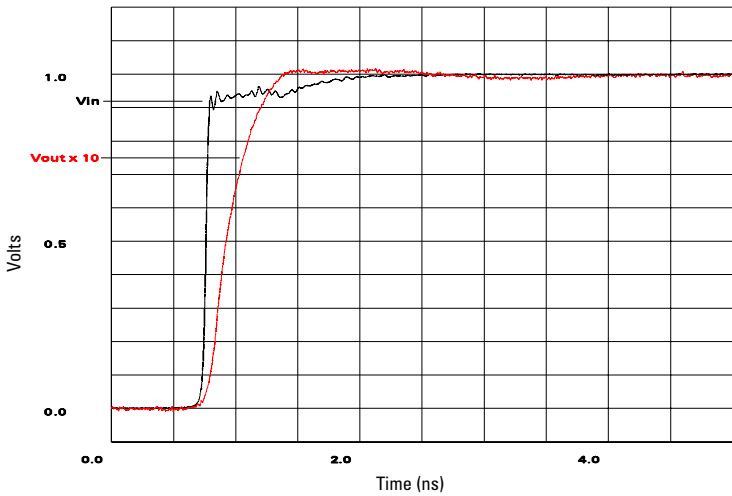

This is not the step response of the probe. The step response of a probe is the output of a probe while the input is a perfect step.

Micro Clip

The Micro Clip is used when easy to connect, hands-free probing of a circuit is required. The Micro Clip can be used on the signal lead, the ground lead, or both.

Although this configuration is damped, it is not optimally damped and should not be used to measure waveforms with rise times less than 1 ns

Figure 2-2

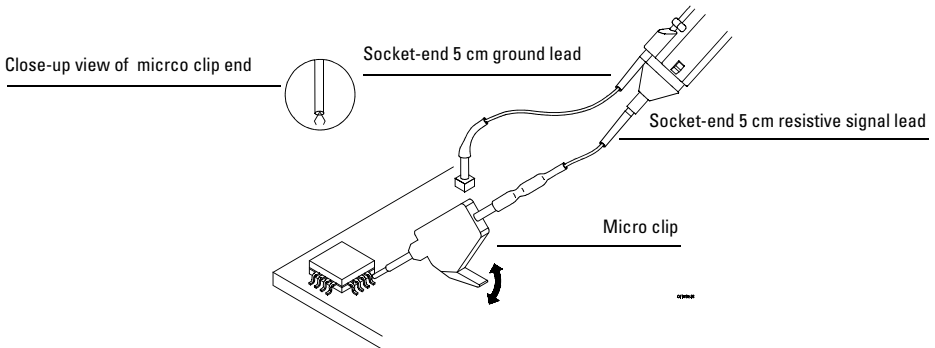

Probing using the micro clip

Undamped Accessories

Probes are often used with accessories that do not contain a damping resistor located at the point being probed. As an example, the accessory might be a lead wire provided with a probe or hand made by the user of a probe. All high bandwidth probes suffer from excessive overshoot and ringing when used with undamped accessories.

In order to illustrate the problems that arise due to the use of undamped accessories, the response of an 1158A with an undamped 5cm signal lead wire is shown on the following pages. The responses shown are very similar to the response of ANY high bandwidth probe that is using an undamped 5cm signal lead wire.

Operating the Probe

Undamped Accessories

5 cm Undamped Signal Wire Lead

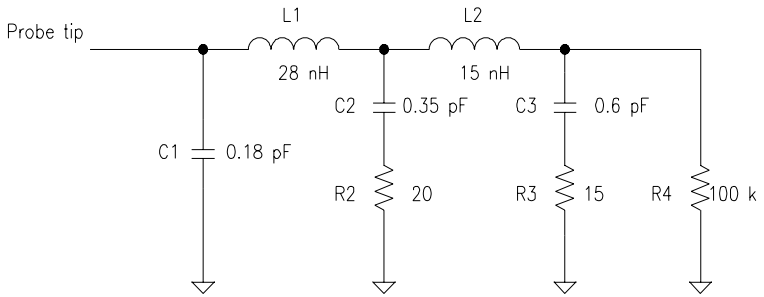

Magnitude Plot of Probe Input Impedance Versus Frequency

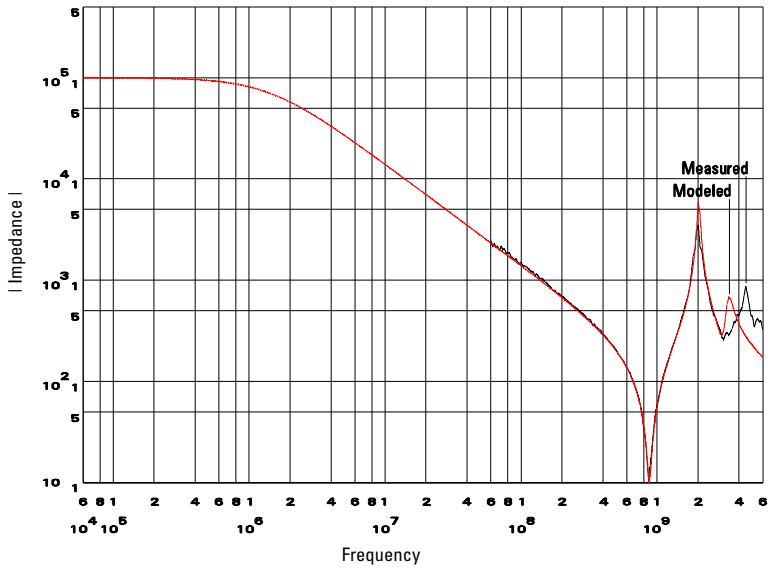

Graph of Vin to Probe and Vout of Probe with a 25 Ω Source

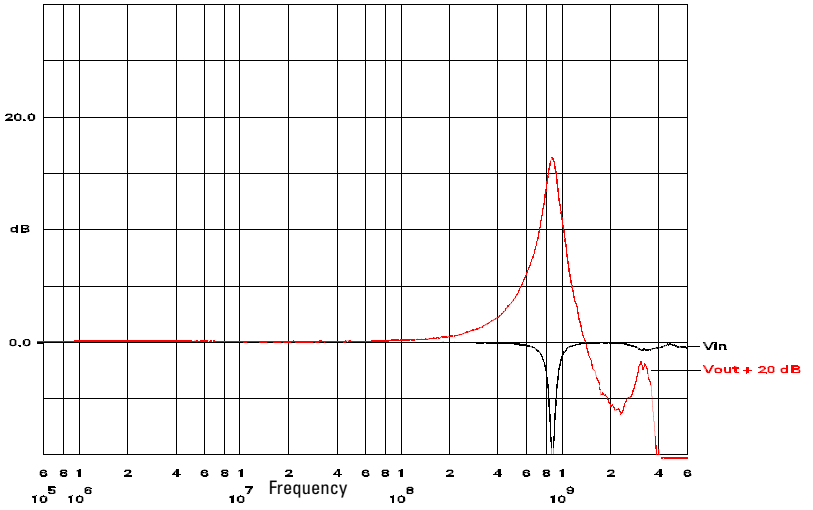

Vout/Vin Frequency Response

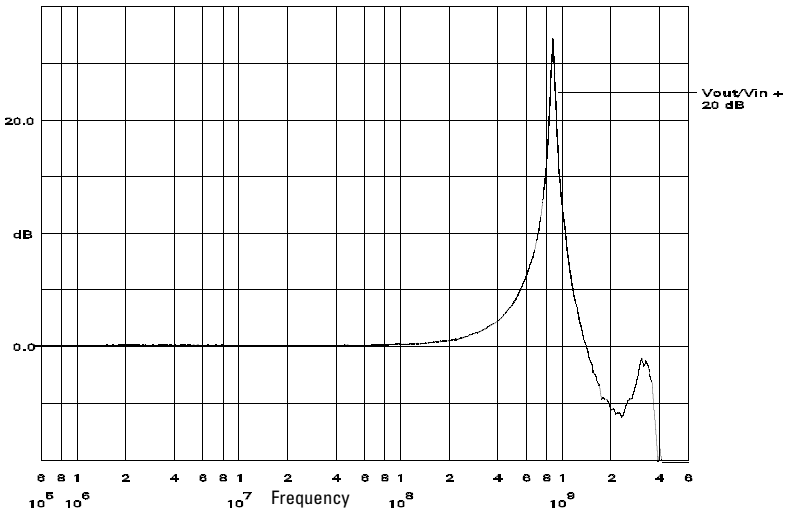

Operating the Probe Undamped Accessories

25 Ω Step Generator With and Without Probe Connected

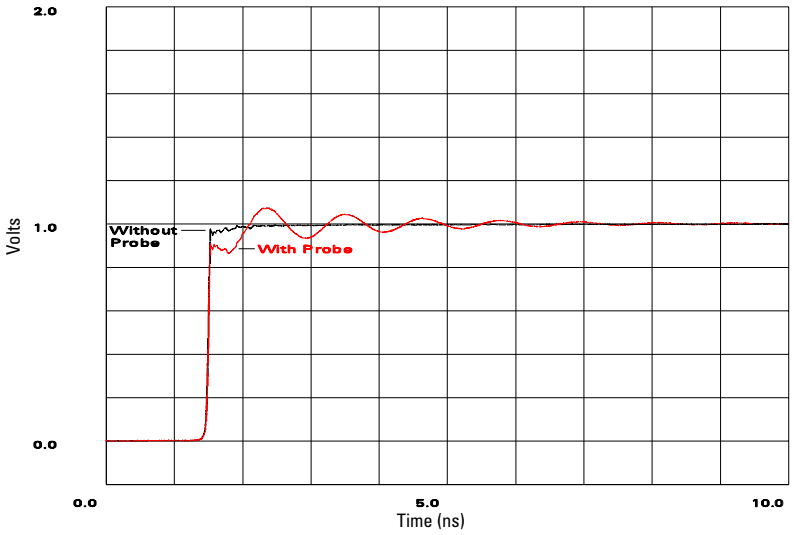

Vin and Vout of Probe

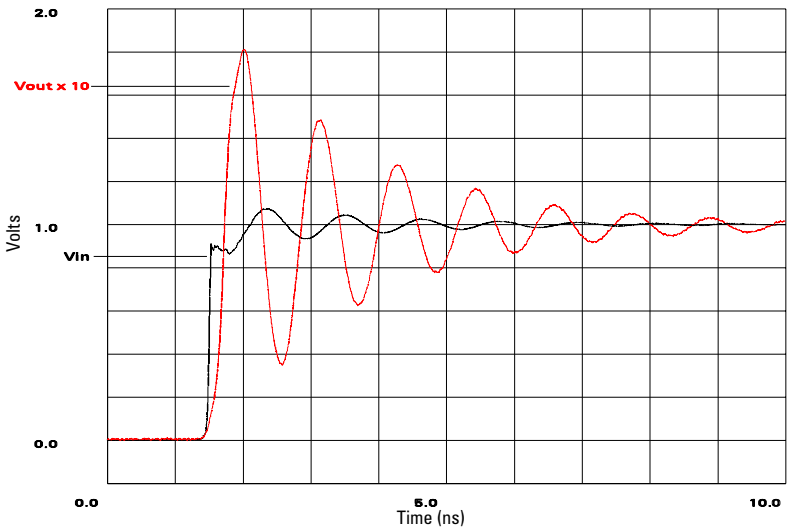

Introduction

This chapter provides service information for the 1156A Active Probe. The following sections are included in this chapter:

- Service strategy
- Returning to Agilent Technologies for service
- Troubleshooting and failure symptoms

Service Strategy

The 1156A Active Probe is a high frequency device with many critical relationships between parts. For example, the frequency response of the amplifier on the hybrid is trimmed to match the output coaxial cable. As a result, to return the probe to optimum performance requires factory repair. If the probe is under warranty, normal warranty services apply.

To return the probe to Agilent Technologies for service

Before shipping the probe to Agilent Technologies, contact your nearest Agilent Technologies Sales Office for additional details.

1 Write the following information on a tag and attach it to the probe.

- Name and address of owner
- probe model number
- probe serial number
- Description of the service required or failure indications

2 Remove all accessories from the probe.

Accessories include all cables. Do not include accessories unless they are associated with the failure symptoms.

3 Protect the probe by wrapping it in plastic or heavy paper.

4 Pack the probe in foam or other shock absorbing material and place it in a strong shipping container.

You can use the original shipping materials or order materials from an Agilent Technologies Sales Office. If neither are available, place 3 to 4 inches of shock absorbing material around the probe and place it in a box that does not allow movement during shipping.

5 Seal the shipping container securely.

6 Mark the shipping container as FRAGILE.

In any correspondence, refer to probe by model number and full serial number.

Troubleshooting

- If your probe is under warranty and requires repair, return it to Agilent Technologies. Contact your nearest Agilent Technologies Service Center.
 - If the failed probe is not under warranty, you may exchange it for a reconditioned probe. See "To Prepare the Probe for Exchange" in this chapter.
-

Failure Symptoms

The following symptoms may indicate a problem with the probe or the way it is used. Possible remedies and repair strategies are included.

The most important troubleshooting technique is to try different combinations of equipment so you can isolate the problem to a specific probe.

Probe Calibration Fails

Probe calibration failure with an oscilloscope is usually caused by improper setup. If the calibration will not pass, check the following:

- Check that the probe passes a waveform with the correct amplitude.
- If the probe is powered by the oscilloscope, check that the offset is approximately correct. The probe calibration cannot correct major failures.
- Be sure the oscilloscope passes calibration without the probe.

Incorrect High Frequency Response

Incorrect high frequency response may be caused by a defective probe, oscilloscope, or an improper use such as poor connections or grounding. See chapter 3, in this guide. If the probe use is correct, try the probe with another oscilloscope.

If the probe appears ac coupled at a high frequency, check for a loose probe tip. The high frequency response of the probe is determined by the accessories used to connect the probe, the amplifier hybrid in the probe, and the probe cable.

If the probe fails to meet the bandwidth specification, factory repair is necessary. Also read "Incorrect Pulse Response" below.

Incorrect Low Frequency Response (pulse flatness)

If the probe's pulse response shows a top that is not flat (incorrect ac gain), it is most likely caused by an inaccurate 50 Ω load on the probe. The probe is designed to work into a 50 Ω load that is accurate within 1.0% ($\pm 0.5 \Omega$). Check the value of the load you are using before you suspect the probe. If the load is accurate, the gain problem with the probe will have to be repaired by the factory. If the probe appears ac coupled at a high frequency, check for a loose or damaged probe tip.

Incorrect Input Resistance

First, check that the probe tip is not loose. The input resistance is determined in the amplifier hybrid in the probe and cannot be repaired in the field. The probe must be returned to the factory for repair.

Incorrect Offset

Incorrect offset can be caused by a misadjusted offset zero (see "Offset Will Not Zero" below) or lack of probe calibration with the oscilloscope.

Offset Will Not Zero

With the input voltage set to 0.0 V and no offset setting, the dc output of the probe should be within ± 3 mV.

If the probe is connected to an Infiniium oscilloscope, the oscilloscope will calibrate out the offset zero error during a probe calibration. If the offset error cannot be calibrated out, return it to Agilent Technologies for repair.

Verifying probe input resistance

Specification: 100 k Ω \pm 1%

Equipment Required

Equipment	Critical Specification	Recommended Model/Part
Digital Multimeter (DMM)	Resistance \pm 1%	34401A

- 1 Connect the DMM probes between the probe tip and the ground at the tip of the probe.
- 2 Set up the DMM to measure resistance.
The resistance should read 100 k Ω \pm 1 k Ω .
- 3 Record the resistance.
Input resistance _____.

Index

A

accessories
 additional 10
 bandwidth 18
 supplied 8

B

bandwidth 18
 specification 11

C

calibration
 failure 44
 probe with oscilloscope 16
cleaning the instrument 49
connecting to oscilloscope 16

D

dimensions 12

F

failure symptoms 44

G

general characteristics 12

I

inspecting probe 7
instrument, cleaning the 49

O

offset errors 45
offset zero
 errors 45
operating environment 12

P

packing for return 43
power requirements 12
probe
 handling 14
 inspection 7
 using 14

R

repair 43
replaceable parts 10
returning probe to Agilent Technologies 43

S

service strategy 42
specifications 11

T

troubleshooting 44

W

weight 12

Safety Notices

This apparatus has been designed and tested in accordance with IEC Publication 1010, Safety Requirements for Measuring Apparatus, and has been supplied in a safe condition. This is a Safety Class I instrument (provided with terminal for protective earthing). Before applying power, verify that the correct safety precautions are taken (see the following warnings). In addition, note the external markings on the instrument that are described under "Safety Symbols."

Warnings

- Before turning on the instrument, you must connect the protective earth terminal of the instrument to the protective conductor of the (mains) power cord. The mains plug shall only be inserted in a socket outlet provided with a protective earth contact. You must not negate the protective action by using an extension cord (power cable) without a protective conductor (grounding). Grounding one conductor of a two-conductor outlet is not sufficient protection.
- Only fuses with the required rated current, voltage, and specified type (normal blow, time delay, etc.) should be used. Do not use repaired fuses or short-circuited fuse-holders. To do so could cause a shock or fire hazard.
- If you energize this instrument by an auto transformer (for voltage reduction or mains isolation), the common terminal must be connected to the earth terminal of the power source.
- Whenever it is likely that the ground protection is impaired, you must make the instrument inoperative and secure it against any unintended operation.

- Service instructions are for trained service personnel. To avoid dangerous electric shock, do not perform any service unless qualified to do so. Do not attempt internal service or adjustment unless another person, capable of rendering first aid and resuscitation, is present.

- Do not install substitute parts or perform any unauthorized modification to the instrument.

- Capacitors inside the instrument may retain a charge even if the instrument is disconnected from its source of supply.

- Do not operate the instrument in the presence of flammable gasses or fumes. Operation of any electrical instrument in such an environment constitutes a definite safety hazard.

- Do not use the instrument in a manner not specified by the manufacturer.

To clean the instrument

If the instrument requires cleaning: (1) Remove power from the instrument. (2) Clean the external surfaces of the instrument with a soft cloth dampened with a mixture of mild detergent and water. (3) Make sure that the instrument is completely dry before reconnecting it to a power source.

Safety Symbols



Instruction manual symbol: the product is marked with this symbol when it is necessary for you to refer to the instruction manual in order to protect against damage to the product..



Hazardous voltage symbol.



Earth terminal symbol: Used to indicate a circuit common connected to grounded chassis.

Notices

© Agilent Technologies, Inc.
2001-2002, 2005

No part of this manual may be reproduced in any form or by any means (including electronic storage and retrieval or translation into a foreign language) without prior agreement and written consent from Agilent Technologies, Inc. as governed by United States and international copyright laws.

Manual Part Number

01156-97002, September 2005

Print History

01156-97000, September 2001
01156-97001, September 2002
01156-97002, September 2005

Agilent Technologies, Inc.
1900 Garden of the Gods Road
Colorado Springs, CO 80907
USA

Restricted Rights Legend

If software is for use in the performance of a U.S. Government prime contract or sub-contract, Software is delivered and licensed as "Commercial computer software" as defined in DFAR 252.227-7014 (June 1995), or as a "commercial item" as defined in FAR 2.101(a) or as "Restricted computer software" as defined in FAR 52.227-19 (June 1987) or any equivalent agency regulation or contract clause. Use, duplication or disclosure of Software is subject to Agilent Technologies' standard commercial license terms, and non-DOD Departments and Agencies of the U.S. Government will receive no greater than Restricted Rights as defined in FAR 52.227-19(c)(1-2) (June 1987). U.S. Government users will receive no greater than Limited Rights as defined in FAR 52.227-14 (June 1987) or DFAR 252.227-7015 (b)(2) (November 1995), as applicable in any technical data.

Document Warranty

The material contained in this document is provided "as is," and is subject to being changed, without notice, in future editions. Further, to the maximum extent permitted by applicable law, Agilent disclaims all warranties, either express or implied,

with regard to this manual and any information contained herein, including but not limited to the implied warranties of merchantability and fitness for a particular purpose. Agilent shall not be liable for errors or for incidental or consequential damages in connection with the furnishing, use, or performance of this document or of any information contained herein. Should Agilent and the user have a separate written agreement with warranty terms covering the material in this document that conflict with these terms, the warranty terms in the separate agreement shall control.

Technology Licenses

The hardware and/or software described in this document are furnished under a license and may be used or copied only in accordance with the terms of such license.

WARNING

A WARNING notice denotes a hazard. It calls attention to an operating procedure, practice, or the like that, if not correctly performed or adhered to, could result in personal injury or death. Do not proceed beyond a WARNING notice until the indicated conditions are fully understood and met.

CAUTION

A CAUTION notice denotes a hazard. It calls attention to an operating procedure, practice, or the like that, if not correctly performed or adhered to, could result in damage to the product or loss of important data. Do not proceed beyond a CAUTION notice until the indicated conditions are fully understood and met.



Agilent Technologies

User's Guide

Agilent Technologies
Printed in the Malaysia
Manual Part Number
01156-97002

