

Sorensen
XHR 1000 Watt Series
Programmable DC
Power Supply

Operation Manual

XHR 7.5-130
XHR 20-50
XHR 33-33
XHR 40-25
XHR 60-18
XHR 100-10
XHR 150-7
XHR 300-3.5
XHR 600-1.7

About AMETEK

AMETEK Programmable Power, Inc., a Division of AMETEK, Inc., is a global leader in the design and manufacture of precision, programmable power supplies for R&D, test and measurement, process control, power bus simulation and power conditioning applications across diverse industrial segments. From bench top supplies to rack-mounted industrial power subsystems, AMETEK Programmable Power is the proud manufacturer of Elgar, Sorensen, California Instruments and Power Ten brand power supplies.

AMETEK, Inc. is a leading global manufacturer of electronic instruments and electromechanical devices with annualized sales of \$2.5 billion. The Company has over 11,000 colleagues working at more than 80 manufacturing facilities and more than 80 sales and service centers in the United States and around the world.

Trademarks

AMETEK is a registered trademark of AMETEK, Inc. Sorensen is a trademark owned by AMETEK, Inc. Other trademarks, registered trademarks, and product names are the property of their respective owners and are used herein for identification purposes only.

Notice of Copyright

XHR 1000 Watt Series Programmable DC Power Supply Operation Manual © 2007 AMETEK Programmable Power, Inc. All rights reserved.

Exclusion for Documentation

UNLESS SPECIFICALLY AGREED TO IN WRITING, AMETEK PROGRAMMABLE POWER, INC. ("AMETEK"):

- (a) MAKES NO WARRANTY AS TO THE ACCURACY, SUFFICIENCY OR SUITABILITY OF ANY TECHNICAL OR OTHER INFORMATION PROVIDED IN ITS MANUALS OR OTHER DOCUMENTATION.
- (b) ASSUMES NO RESPONSIBILITY OR LIABILITY FOR LOSSES, DAMAGES, COSTS OR EXPENSES, WHETHER SPECIAL, DIRECT, INDIRECT, CONSEQUENTIAL OR INCIDENTAL, WHICH MIGHT ARISE OUT OF THE USE OF SUCH INFORMATION. THE USE OF ANY SUCH INFORMATION WILL BE ENTIRELY AT THE USER'S RISK, AND
- (c) REMINDS YOU THAT IF THIS MANUAL IS IN ANY LANGUAGE OTHER THAN ENGLISH, ALTHOUGH STEPS HAVE BEEN TAKEN TO MAINTAIN THE ACCURACY OF THE TRANSLATION, THE ACCURACY CANNOT BE GUARANTEED. APPROVED AMETEK CONTENT IS CONTAINED WITH THE ENGLISH LANGUAGE VERSION, WHICH IS POSTED AT WWW.PROGRAMMABLEPOWER.COM.

Date and Revision

February 2009 Revision C

Part Number

TM-XROP-01XN

Contact Information

Telephone: 800 733 5427 (toll free in North America)
858 450 0085 (direct)
Fax: 858 458 0267
Email: sales@programmablepower.com
service@programmablepower.com
Web: www.programmablepower.com

This page intentionally left blank.

Important Safety Instructions

Before applying power to the system, verify that your product is configured properly for your particular application.

	Hazardous voltages may be present when covers are removed. Qualified personnel must use extreme caution when servicing this equipment. Circuit boards, test points, and output voltages also may be floating above (below) chassis ground.
	The equipment used contains ESD sensitive parts. When installing equipment, follow ESD Safety Procedures. Electrostatic discharges might cause damage to the equipment.

Only *qualified personnel* who deal with attendant hazards in power supplies, are allowed to perform installation and servicing.

Ensure that the AC power line ground is connected properly to the Power Rack input connector or chassis. Similarly, other power ground lines including those to application and maintenance equipment *must* be grounded properly for both personnel and equipment safety.

Always ensure that facility AC input power is de-energized prior to connecting or disconnecting any cable.

In normal operation, the operator does not have access to hazardous voltages within the chassis. However, depending on the user's application configuration, **HIGH VOLTAGES HAZARDOUS TO HUMAN SAFETY** may be normally generated on the output terminals. The customer/user must ensure that the output power lines are labeled properly as to the safety hazards and that any inadvertent contact with hazardous voltages is eliminated.

Guard against risks of electrical shock during open cover checks by not touching any portion of the electrical circuits. Even when power is off, capacitors may retain an electrical charge. Use safety glasses during open cover checks to avoid personal injury by any sudden component failure.

Neither AMETEK Programmable Power Inc., San Diego, California, USA, nor any of the subsidiary sales organizations can accept any responsibility for personnel, material or inconsequential injury, loss or damage that results from improper use of the equipment and accessories.

SAFETY SYMBOLS

	WARNING Risk of Electrical Shock		CAUTION Refer to Accompanying Documents
	Off (Supply)		Direct Current (DC)
	Standby (Supply)		Alternating Current (AC)
	On (Supply)		Three-Phase Alternating Current
	Protective Conductor Terminal		Earth (Ground) Terminal
	Fuse		Chassis Ground

This page intentionally left blank.

Product Family: XHR 1000 Watt Series Programmable DC Power Supply

Warranty Period: Five Years

WARRANTY TERMS

AMETEK Programmable Power, Inc. ("AMETEK"), provides this written warranty covering the Product stated above, and if the Buyer discovers and notifies AMETEK in writing of any defect in material or workmanship within the applicable warranty period stated above, then AMETEK may, at its option: repair or replace the Product; or issue a credit note for the defective Product; or provide the Buyer with replacement parts for the Product.

The Buyer will, at its expense, return the defective Product or parts thereof to AMETEK in accordance with the return procedure specified below. AMETEK will, at its expense, deliver the repaired or replaced Product or parts to the Buyer. Any warranty of AMETEK will not apply if the Buyer is in default under the Purchase Order Agreement or where the Product or any part thereof:

- is damaged by misuse, accident, negligence or failure to maintain the same as specified or required by AMETEK;
- is damaged by modifications, alterations or attachments thereto which are not authorized by AMETEK;
- is installed or operated contrary to the instructions of AMETEK;
- is opened, modified or disassembled in any way without AMETEK's consent; or
- is used in combination with items, articles or materials not authorized by AMETEK.

The Buyer may not assert any claim that the Products are not in conformity with any warranty until the Buyer has made all payments to AMETEK provided for in the Purchase Order Agreement.

PRODUCT RETURN PROCEDURE

1. Request a Return Material Authorization (RMA) number from the repair facility (**must be done in the country in which it was purchased**):
 - **In the USA**, contact the AMETEK Repair Department prior to the return of the product to AMETEK for repair:
Telephone: 800-733-5427, ext. 2295 or ext. 2463 (toll free North America)
858-450-0085, ext. 2295 or ext. 2463 (direct)
 - **Outside the United States**, contact the nearest Authorized Service Center (ASC). A full listing can be found either through your local distributor or our website, www.programmablepower.com, by clicking Support and going to the Service Centers tab.
2. When requesting an RMA, have the following information ready:
 - Model number
 - Serial number
 - Description of the problem

NOTE: Unauthorized returns will not be accepted and will be returned at the shipper's expense.

NOTE: A returned product found upon inspection by AMETEK, to be in specification is subject to an evaluation fee and applicable freight charges.

This page intentionally left blank.

Contents

	About This Manual	vii
	List of Figuresxi
	List of Tablesxiii
Section 1. Features and Specifications	Description	15
	Features and Options	15
	Front Panel Controls	16
	Rear Panel Connectors and Switch	18
	Rear Panel Illustrations	18
	SW1 Programming Switch	19
	J2 Programming Connector	20
	Specifications	23
	Electrical Specifications	23
	Additional Electrical Specifications	26
	Input Conditions	26
	Electrical Characteristics	27
	Remote Programming and Monitoring	27
	Environmental Specifications	28
	Approvals	28
	Mechanical Specifications	29
	Dimensions	30
Section 2. Installation	Basic Setup Procedure	31
	Inspection, Cleaning, and Packing	32
	Initial Inspection	32
	Periodic Cleaning	32
	Returning Power Supplies to the Manufacturer	33
	Return Material Authorization Policy	33
	Packaging for Shipping or Storage	34
	Location, Mounting, and Ventilation	35
	Rack Mounting	35
	Ventilation	35
	AC Input Power	36
	Functional Tests	37
	Equipment Required	37
	Power-on Check	37
	Voltage Mode Operation Check	37
	Current Mode Operation Check	38
	Front Panel Function Check	38
Load Connection	39	
Load Wiring	39	
Making Load Connections	41	
Inductive Loads	42	
Connecting Single Loads	45	
Connecting Multiple Loads	45	

	Local and Remote Sensing	48
	Sense Wiring	48
	Local Sensing	48
	Using Remote Sensing	48
Section 3.	Standard Operation	51
Local	Operating Modes and Automatic Crossover	51
Operation	Shipped Configuration (Local Control Mode)	53
	Setting Output Voltage and Current Limit	53
	Using Multiple Supplies	54
	Configuring Multiple Supplies for Series Operation	55
	Configuring Multiple Supplies for Parallel Operation	56
	Configuring Multiple Supplies for Split Supply Operation	57
	Using Over Voltage Protection (OVP)	59
	Front Panel OVP Operation	59
	Resetting the OVP Circuit	60
	Using the Shutdown Function	61
	STANDBY Switch	61
	Controlling the Shutdown Function via the J2 Connector	61
	Over Temperature Protection (OTP)	63
	User Diagnostics	64
	Emergency Shutdown	64
	Unusual or Erratic Operation	64
	Troubleshooting for Operators	64
Section 4.	Remote Analog Programming of Output Voltage and Current Limit	67
Remote	Remote Programming Options	67
Operation	Remote Analog Programming Procedure	68
	Sample Configuration	70
	Remote Monitoring of Output Voltage and Current	71
	Readback Signals	71
	Using the Isolated Programming (ISOL) Interface Option	72
	ISOL Specifications	72
	ISOL Setup and Operating Instructions	73
	ISOL Calibration	73
Section 5.	Calibration Setup	75
Calibration	Service Environment and Precautions	75
	Equipment Required	75
	Front Panel Calibration	76
	Additional Setup	76
	Voltmeter Calibration	76
	Ammeter Calibration	77
	Over Voltage Protection (OVP) Calibration	77
	Calibrating for Programming Accuracy	78
	Voltage Programming Circuit Calibration	79
	Current Programming Circuit Calibration	79
	Calibrating for Readback Accuracy	80
	Output Voltage Monitor Circuit Calibration	81
	Output Current Monitor Circuit Calibration	82

List of Figures

Figure 1.1	Power Supply Front Panel	17
Figure 1.2	Rear Panel with Bus Bar.	18
Figure 1.3	Rear Panel with High Voltage Output Connector	19
Figure 1.4	SW1 Programming Switch	19
Figure 1.5	J2 Programming Connector	21
Figure 1.6	Dimensional Drawings	30
Figure 2.1	Shipping or Storage Carton Label	34
Figure 2.2	Maximum Load Wire Length for 1 V Line Drop.	40
Figure 2.3	Bus Bar Shield	42
Figure 2.4	Typical Load Connection Hardware	43
Figure 2.5	Output Connector	44
Figure 2.6	Single Load with Local Sensing (Default).	45
Figure 2.7	Single Load with Remote Sensing	45
Figure 2.8	Multiple Loads with Local Sensing	46
Figure 2.9	Multiple Loads with Remote Sensing	47
Figure 2.10	Connecting Remote Sense Lines	50
Figure 3.1	Operating Modes	52
Figure 3.2	Series Operation of Multiple Supplies.	55
Figure 3.3	Parallel Operation of Multiple Supplies.	56
Figure 3.4	Split Supply Operation of Multiple Supplies	57
Figure 3.5	Split Supply Operation of Multiple Supplies	58
Figure 3.6	Shutdown Programming with Active Low Signal	62
Figure 3.7	Shutdown Programming with Active High Signal	62
Figure 4.1	Connecting Programming Sources to J2 Connector	70
Figure 4.2	Sample Analog Programming Configuration	70
Figure 4.3	0-5 Vdc Output Voltage and Current Monitoring.	71
Figure 4.4	0-10 Vdc Output Voltage and Current Monitoring.	72
Figure 5.1	Front Panel Calibration Locations.	76
Figure 5.2	Voltage and Current Programming Calibration Locations	78
Figure 5.3	Voltage Current and Monitor Calibration Locations	80

List of Figures

List of Tables

Table 1.1	SW1 Switch Functions	20
Table 1.2	Electrical Specifications for 7.5 V to 40 V Models	24
Table 1.3	Electrical Specifications for 60 V to 600 V Models	25
Table 2.1	Basic Setup Procedure	31
Table 2.2	Power Cords	36
Table 2.3	Current Carrying Capacity for Wiring	39
Table 3.1	Shipped Configuration (Local Control Mode)	53
Table 3.2	Switch Settings for Shutdown Circuit Logic	61
Table 3.3	Switch Settings for Over Temperature Recovery Options	63
Table 3.4	Quick Diagnostics	65
Table 4.1	Power Supply Settings for Different Programming Sources	69
Table 4.2	Power Supply Settings for Remote Monitoring of Readback Signals	71

List of Tables

Section 1. Features and Specifications

Description

The 1000 watt DC output power supplies provide low noise, precisely regulated, variable DC output. Typically they are used for bench and automated test equipment (ATE) applications. Each unit includes over voltage protection and thermal shutdown as standard features. Universal AC input allows you to use line voltages globally without resetting switches or adding options. Built-in power factor correction gives you full output power from low current/low voltage outlets, reduces power line interference, and allows you to meet international regulations.

You can select from several remote control choices for either analog or digital control. For analog control, choose from standard analog control or optional 4-channel isolated programming. Digital control options include RS-232 control or GPIB programming. You can use the power supply on your benchtop or rack mounted; each supply occupies less than 3-1/2 in. (2 U) of vertical space. Whether you are powering batteries, development circuits, and magnet coils or running ATE systems, the power supply provides the precision and power that you need.

Features and Options

- Models available with voltage ranges from 0-7.5 Vdc to 0-600 Vdc; current ranges from 0-1.7 A to 0-130 A.
- Internal power factor correction allows operation from a standard 120 Vac, 15 A outlet.
- Thermal shutdown, latching or auto reset.
- Front panel control of Over Voltage Protection (OVP).
- Simultaneous digital display of both voltage and current.
- Ten-turn front panel voltage and current controls for high resolution setting of the output voltage and current from zero to the rated output.
- Automatic mode crossover into current or voltage mode.
- Front panel push button control of output standby mode, and preview of voltage, current, or OVP set points. Front panel LED indicators for voltage and current mode operation, OVP, remote programming mode, and shutdown.
- Multiple units can be connected in parallel or in series to provide increased current or voltage.

Features and Specifications

Front Panel Controls

- Remote analog voltage and current limit programming with selectable programming ranges.
- External monitor signals for output voltage and current.
- Isolated analog remote programming control of the output voltage or current and isolated readback of output voltage and current with the optional ISOL interface.
- Optional internal GPIB or RS-232 computer control for complete remote programming and readback capability.

Front Panel Controls

See Figure 1.1 to review the controls, LEDs, and meters located on the power supply's front panel. Check the following sections for additional descriptions of front panel controls and functions.

- [“Mechanical Specifications” on page 29](#)
- “Functional Tests” on page 37
- “Local Operation” on page 51

Features and Specifications
Front Panel Controls

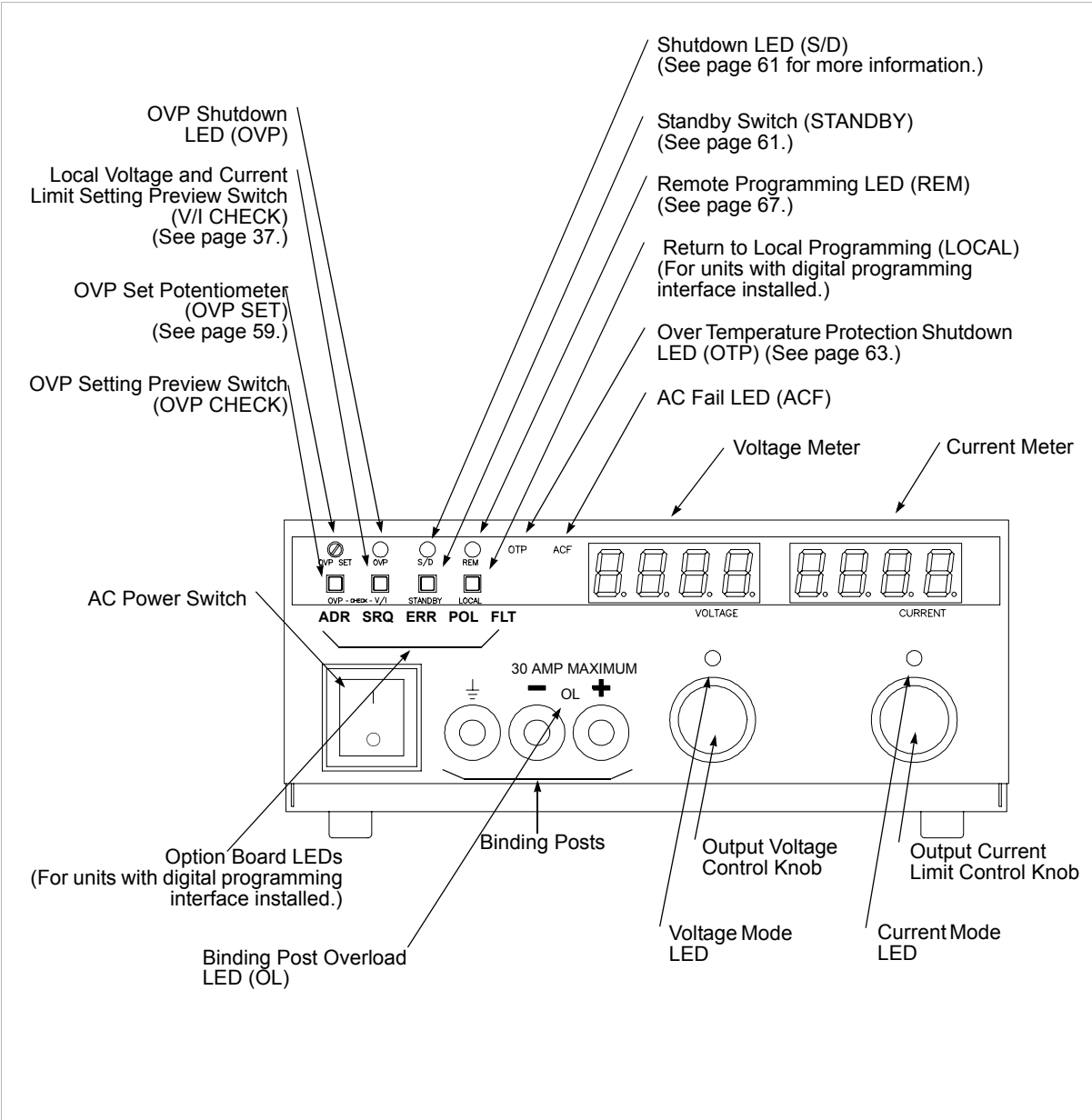

Figure 1.1 Power Supply Front Panel
 (For all models.)

Features and Specifications

Rear Panel Connectors and Switch

Rear Panel Connectors and Switch

The output terminals for the low voltage models (7.5 V to 40 V) are bus bars. The high voltage models (60 V to 600 V) use a wire clamp connector. See Figure 1.2 and Figure 1.3 to identify the switches and connectors on the rear panel.

Use the SW1 Programming, Monitoring, and Shutdown Select switch and the J2 Programming, Monitoring, and Sense connector to choose among several remote programming and monitoring options. See the following sections for more information about remote programming:

- “SW1 Programming Switch” on page 19
- “J2 Programming Connector” on page 20
- Section 4. Remote Operation

Rear Panel Illustrations

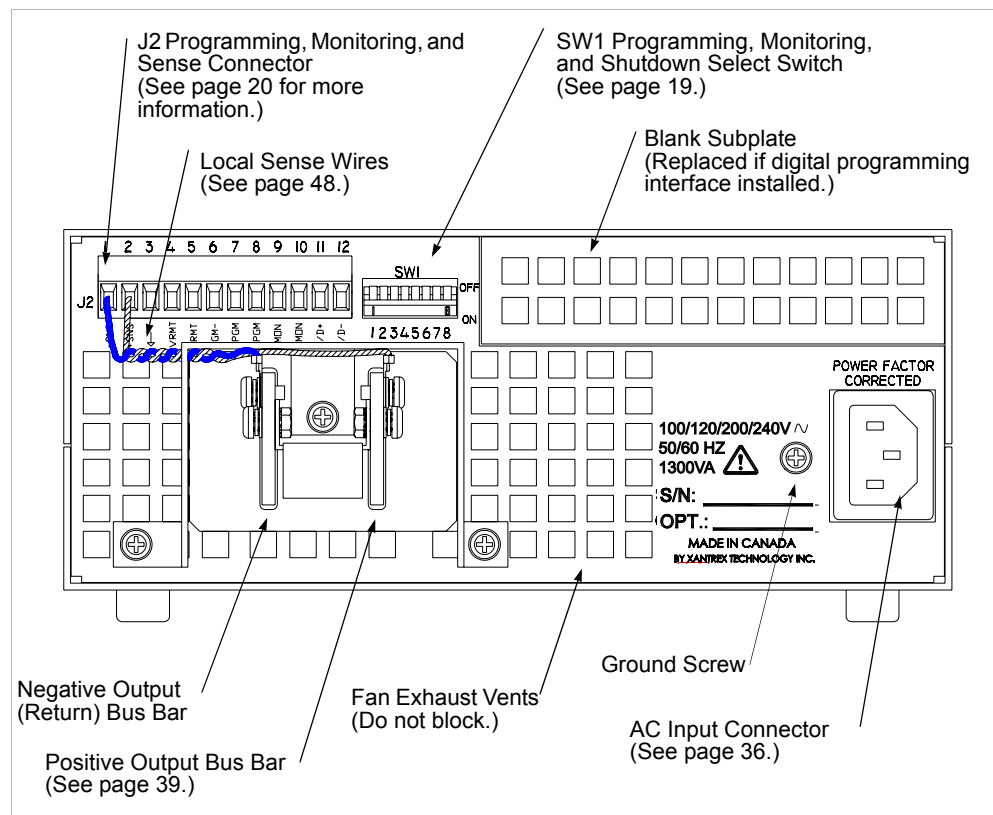

Figure 1.2 Rear Panel with Bus Bar
(For 7.5 V to 40 V models.)

Features and Specifications

Rear Panel Connectors and Switch

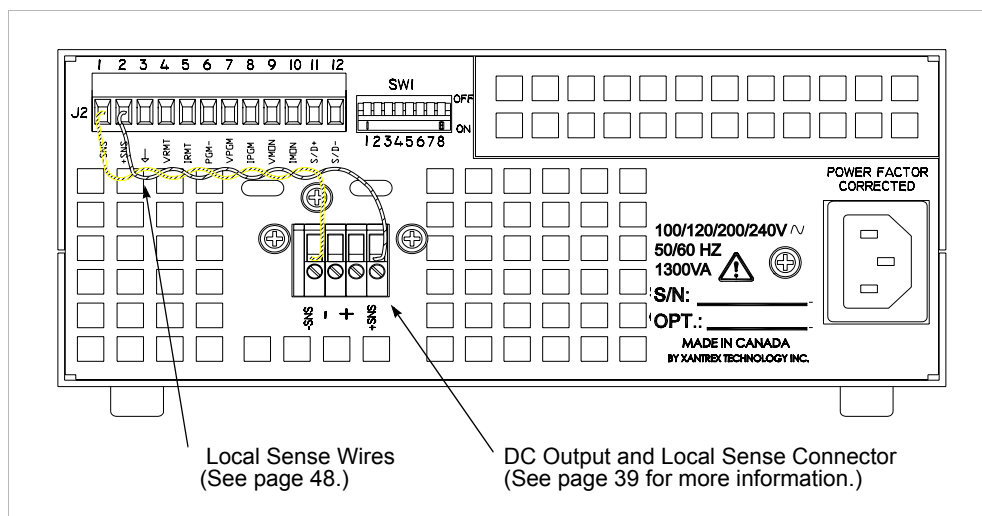

Figure 1.3 Rear Panel with High Voltage Output Connector
(For 60 V to 600 V models.)

SW1 Programming Switch

The SW1 Programming, Monitoring, and Shutdown Select switch is an 8-position piano DIP switch located on the power supply's rear panel. The SW1 switch enables you to choose:

- Output voltage and current limit programming scales
- Output voltage and current monitor scales
- Remote shutdown circuit logic
- Resistive programming of output voltage or current limit
- Over temperature shutdown mode

The power supply is shipped with the SW1 switch set in the default operating configuration, as illustrated in Figure 1.4.

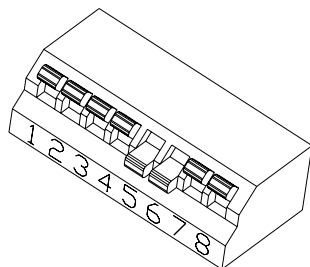

Figure 1.4 SW1 Programming Switch
(Shown in its default configuration.)

Features and Specifications

Rear Panel Connectors and Switch

See Table 1.1 for a list of the functions assigned to each SW1 switch.

Table 1.1 SW1 Switch Functions

Switch	Function	OFF (Open) ¹	ON (Closed) ¹
SW1-1	1 mA current source for resistive programming of output voltage.	<u>Voltage source programming</u>	Resistive programming
SW1-2	1 mA current source for resistive programming of output current limit.	<u>Voltage source programming</u>	Resistive programming
SW1-3	Output voltage programming source range select.	<u>0-5 V</u>	0-10 V
SW1-4	Output current limit programming source range select.	<u>0-5 V</u>	0-10 V
SW1-5	Output voltage monitor range select.	0-10 V	<u>0-5 V</u>
SW1-6	Output current monitor range select.	0-10 V	<u>0-5 V</u>
SW1-7	Remote shutdown logic select.	<u>HIGH=OFF</u>	HIGH=ON
SW1-8	Over temperature shutdown reset mode select.	<u>Auto reset</u>	Latch OFF

1. Factory defaults underlined.

Resetting the Switches The rear panel is labelled with OFF at the top of the switch and ON at the bottom. Any of the eight switches on SW1 is OFF (OPEN) when it has been flipped up to break contact, ON (CLOSED) when flipped down to close contact.

Before making any changes to the switch settings, disable the power supply output. Either turn OFF the supply, or place the supply in shutdown mode by pressing the front panel STANDBY button to its ON position. Once output is disabled, use any small, straight-bladed screwdriver to change the switch settings.

J2 Programming Connector

The J2 Programming, Monitoring, and Sense connector is a 12-terminal wire clamp connector located on the power supply's rear panel. The J2 connector provides access to the following functions:

- remote programming of output voltage and/or current limit
- remote monitoring of calibrated readback signals for output voltage and output current
- remote control of the shutdown function using 2.5-15 V or TTL-compatible signals
- remote sensing of output voltage

Features and Specifications

Rear Panel Connectors and Switch

See Figure 1.5 to identify the function of each of the 12 terminals on the J2 connector.

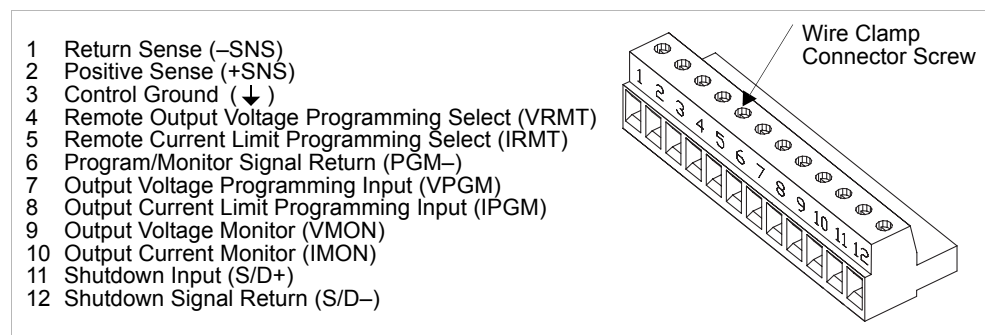

Figure 1.5 J2 Programming Connector

Making J2 Connections



CAUTION

To maintain the isolation of the power supply output and prevent ground loops, use an isolated (ungrounded) programming source when operating the power supply via remote analog control at the J2 connector.



CAUTION

Do not attempt to bias the Program/monitor signal return (J2-6) relative to the power supply output return, as they are connected internally. Use the Isolated Programming (ISOL) option for control from programming sources at potentials differing from the supply output return.

Make connections to the J2 connector using its screw-type wire clamps. Before making any connections, turn the power supply OFF and wait until the front panel displays have gone out. You can unplug the connector from the back of the unit in order to make it easier to install the required wiring.

Features and Specifications

Rear Panel Connectors and Switch

Wiring



WARNING

There is a potential shock hazard at the output and J2 terminals when using a power supply with a rated output greater than 40 V. Use load wiring with a minimum insulation rating equivalent to the maximum output voltage of the power supply. For example, select TEW-105, 105 °C, 600 V wiring for use with a 600 V, 1.7 A model power supply

For lowest noise performance, make connections to the J2 connector with either individually or group shielded 18-22 AWG (0.3-0.8 mm²) wire. Maintain the shield to within 1.5in. (40 mm) of the end of each wire. Strip 0.26.in (6.5 mm) of insulation, insert into the correct terminal, and tighten the wire clamp. You must ground the shield(s) to the power supply chassis with a connection less than 1.5.in (40 mm) long.

Specifications

Electrical Specifications Specifications are warranted over a temperature range of 0 to 40 °C with default local sensing.

The tables on the following pages post maximum values for model-dependent specifications.

Specifications which are different due to measurements being taken at the front panel binding posts are identified, where they occur, in the tables.

Specifications are subject to change without notice.

Features and Specifications

Specifications

Table 1.2 Electrical Specifications for 7.5 V to 40 V Models

Models	7.5-130	20-50	33-33	40-25
Output Ratings:				
Output Voltage	0-7.5 V	0-20 V	0-33 V	0-40 V
Output Current	0-130 A	0-50 A	0-33 A	0-25 A
Output Power	975 W	1000 W	1089 W	1000 W
At the front panel binding posts:				
Output Current	0-30 A	0-30 A	0-30A	
Output Power	225 W	600 W	990 W	
Line Regulation: ¹				
Voltage (0.01% of Vmax + 2 mV)	3 mV	4 mV	5 mV	8 mV
Current (0.01% of Imax + 1 mA)	14 mA	6 mA	4.3 mA	2.8 mA
Load Regulation: ²				
Voltage (0.01% of Vmax + 2 mV)	3 mV	4 mV	5 mV	6 mV
Current (0.05% of Imax + 1 mA)	66 mA	26 mA	18 mA	14 mA
At the front panel binding posts:				
Voltage	650 mV	650 mV	650 mV	500 mV
Meter Accuracy:				
Voltage (1% of Vmax + 1 count)	0.09 V	0.3 V	0.43 V	0.5 V
Current (1% of Imax + 1 count)	1.4 A	0.6 A	0.43 A	0.35 A
Output Noise and Ripple (V):				
rms	10 mV	10 mV	7.5 mV	7.5 mV
p-p (0-20 MHz)	70 mV	70 mV	75 mV	75 mV
At the front panel binding posts:				
p-p (0-20 MHz)	250 mV	250 mV	350 mV	350 mV
Drift (8 hours): ³				
Voltage (0.05% of Vmax)	3.75 mV	10 mV	16.5 mV	20 mV
Current (0.1% of Imax)	130 mA	50 mA	33 mA	25 mA
Temperature Coefficient: ⁴				
Voltage (0.02% of Vmax/°C)	1.5 mV	4 mV	6.6 mV	8 mV
Current (0.03% of Imax/°C)	39 mA	15 mA	9.9 mA	7.5 mA
Maximum Remote Sense Line Drop Compensation ⁵				
	3 V/line	5 V/line	5 V/line	5 V/line
OVP Adjustment Range: (5% to 110% of Vmax)				
	0.375-8.25 V	1-22 V	1.65-36.3 V	2-44 V
Efficiency ⁶				
	81%	83%	83%	83%

1. For input voltage variation over the AC input voltage range, with constant rated load.

2. For 0-100% load variation, with constant nominal line voltage. Measured at the rear panel output connector unless stated otherwise.

3. Maximum drift over 8 hours with constant line, load, and temperature, after 30-minute warm-up.

4. Change in output per °C change in ambient temperature, with constant line and load.

5. Line drop is subtracted from total voltage available at supply output.

6. Typical efficiency at 115 Vac input and rated output power.

Table 1.3 Electrical Specifications for 60 V to 600 V Models

Models	60-18	100-10	150-7	300-3.5	600-1.7
Output Ratings:					
Output Voltage	0-60 V	0-100 V	0-150 V	0-300 V	0-600 V
Output Current	0-18 A	0-10 A	0-7 A	0-3.5 A	0-1.7 A
Output Power	1080 W	1000 W	1050 W	1050 W	1020 W
Line Regulation: ¹					
Voltage (0.01% of Vmax + 2 mV)	8 mV	12 mV	17 mV	32 mV	62 mV
Current (0.01% of Imax + 1 mA)	2.8 mA	2 mA	1.7 mA	1.3 mA	1.2 mA
Load Regulation: ²					
Voltage (0.01% of Vmax + 2 mV)	8 mV	12 mV	17 mV	32 mV	62 mV
Current (0.05% of Imax + 1 mA)	10 mA	6 mA	4.5 mA	3 mA	2 mA
At the front panel binding posts:					
Voltage	400 mV	300 mV	200 mV	100 mV	62 mV
Meter Accuracy:					
Voltage (1% of Vmax + 1 count)	0.7 V	1.1 V	1.6 V	4 V	7 V
Current (1% of Imax + 1 count)	0.19 A	0.11 A	0.08 A	0.05 A	0.03 A
Output Noise and Ripple (V):					
rms	10 mV	10 mV	20 mV	30 mV	120 mV
p-p (0-20MHz)	75 mV	100 mV	150 mV	250 mV	500 mV
At the front panel binding posts:					
p-p (0-20MHz)	400 mV	400 mV	450 mV	500 mV	700 mV
Drift (8 hours): ³					
Voltage (0.05% of Vmax)	30 mV	50 mV	75 mV	150 mV	300 mV
Current (0.05% of Imax)	18 mA	10 mA	7 mA	3.5 mA	1.7 mA
Temperature Coefficient: ⁴					
Voltage (0.02% of Vmax/°C)	12 mV	20 mV	30 mV	60 mV	120 mV
Current (0.03% of Imax/°C)	5.4 mA	3 mA	2.1 mA	1.1 mA	0.48 mA
Maximum Remote Sense Line Drop Compensation ⁵					
	5 V/line	5 V/line	5 V/line	5 V/line	5 V/line
OVP Adjustment Range (5% to 110% of Vmax)					
	3-66 V	5-110 V	7.5-165 V	15-330 V	30-660 V
Efficiency ⁶					
	84%	84%	85%	85%	85%

1. For input voltage variation over the AC input voltage range, with constant rated load.
2. For 0-100% load variation, with constant nominal line voltage. Measured at the rear panel output connector unless stated otherwise.
3. Maximum drift over 8 hours with constant line, load, and temperature, after 30-minute warm-up.
4. Change in output per °C change in ambient temperature, with constant line and load.
5. Line drop is subtracted from total voltage available at supply output.
6. Typical efficiency at 115 Vac input and rated output power.

Features and Specifications

Additional Electrical Specifications

Additional Electrical Specifications

Voltage Mode Transient Response (Time for the output voltage to recover within 0.5% of its previous level after a step change in load current of up to 50% of the rated output.)	1 ms
Time delay from power on until output stable	4 s maximum

Input Conditions

Rated AC Input Voltage	100/120/200/220/230/240 Vac (nominal)
Maximum AC Input Rating	1300 VA
Operational AC Input Voltage Range	85-250 Vac; power factor corrected. Derate maximum output power to 900 W for AC input less than 95 V.
Maximum Input Current	13 A maximum at 100 Vac, 11 A maximum at 120 Vac, 6 A maximum at 220 Vac.
Input Frequency Range	47–63 Hz
Power Factor	0.99 minimum for full load and 120 Vac input

Electrical Characteristics

Switching Frequency	7.5 V to 300 V models: nominal 125 kHz (250 kHz output ripple) 600 V model nominal 62.5 kHz (125 kHz output ripple)
Output Hold-up Time	Greater than 10 ms with interruption of AC line, for nominal AC input and full load.
Maximum Voltage Differential from output to safety ground	±600 Vdc
Isolation Voltage	Input to output: 1350 Vac

Remote Programming and Monitoring

Remote Start/Stop and Interlock	2.5-15 V signal or TTL-compatible input, selectable logic. Input impedance: 1 k (in series with one diode drop).
Remote Analog Programming (Full Scale Input)	Voltage and current programming inputs (source must be isolated): 0-5 k, 0-10 k resistances; 0-5 V (default), 0-10 V voltage sources; Input impedance (V and I): approximately 475 k.
Remote monitoring	Output voltage and current: 0-5 V, 0-10 V (default); Output impedance (V and I): approximately 221 Ω ; Output short circuit current: approximately 50 mA.
Remote Programming and Monitoring Accuracy	1% zero to full scale output for the default range.
Maximum Remote Sense Line Drop Compensation. (Line drop must be deducted from the supply's maximum output voltage.)	7.5 V models: 3 V/line. 20 V to 600 V models: 5 V/line.
Isolated Program and Readback (V & I) (Optional)	0-5 V (ISOL interface). Input impedance: 200 k. Output impedance: 21 Ω
Digital Control (Optional)	RS-232, GPIB or GPIB-M (multichannel)

Features and Specifications

Environmental Specifications

Environmental Specifications

Operating Ambient Temperature	0 to 40 °C.
Storage Temperature Range	– 40 ° to 85 °C
Humidity Range	Up to 80% RH, non-condensing
Operating Altitude	Up to 6,500 feet (2000 m)
Installation Category	II
Pollution Degree	2

Approvals

Units marked with c(CSA)us are CSA certified to:
Canadian safety standard CAN/CSA C22.2 No. 61010.1-92 and
USA safety standard UL 61010B-1.

Units marked with CE meet:
EMC Directive (standards EN50081-2 and EN50082-1) and
Low Voltage Directive (safety standard IEC 61010:1990 +A.1:1992 +A.2:1995).

Meets FCC part 15 Class A limits for radio emissions.

Meets Canadian EMC standard ICES-001, Class A limits.

Mechanical Specifications

Front Panel Voltage and Current Control	10-turn voltage and current potentiometers
Front Panel Voltage Control Resolution	0.02% of maximum voltage
Front Panel Voltage and Current Meters	3.5-digit numeric LED displays (for accuracy specifications, see Table 1.2 and Table 1.3)
AC Input Connector Type	IEC 320 Connector, appropriate power cord for destination country.
Front Panel Output	5-way binding posts: maximum current limit 30 A
OVP Control	Screwdriver-set potentiometer on front panel
Input Fuses	20 A, 250 V, 5 x 20 mm slow fuses, location: A5 PCB, F321, 325; 0.005 A, 250 V, 5 x 20 mm fast fuse, location: A3 PCB, F1.
Main Output Connector	7.5 V to 40 V models: nickel-plated copper bus bars; 60 V to 600 V models: 4-terminal wire clamp connector for DC output and local sense.
Analog Programming, Monitoring, and Sense Connector (2-piece)	12-terminal wire clamp connector
Chassis Ground	Chassis ground screw located on rear panel for bonding connections
Cooling	Fan cooled. Air exhausts to rear. Over temperature shutdown: automatic restart or latch off (switch-selectable).
Mounting	Optional rack mount pan. (RM3-XHR)
Size (one unit)	87.0 mm H x 214.6 mm W x 472.2 mm D (3.425in. H x 8.45in. W x 18.59in. D)
Weight (one unit)	Approximately 6.4 kg (14 lb.)

Features and Specifications

Dimensions

Dimensions

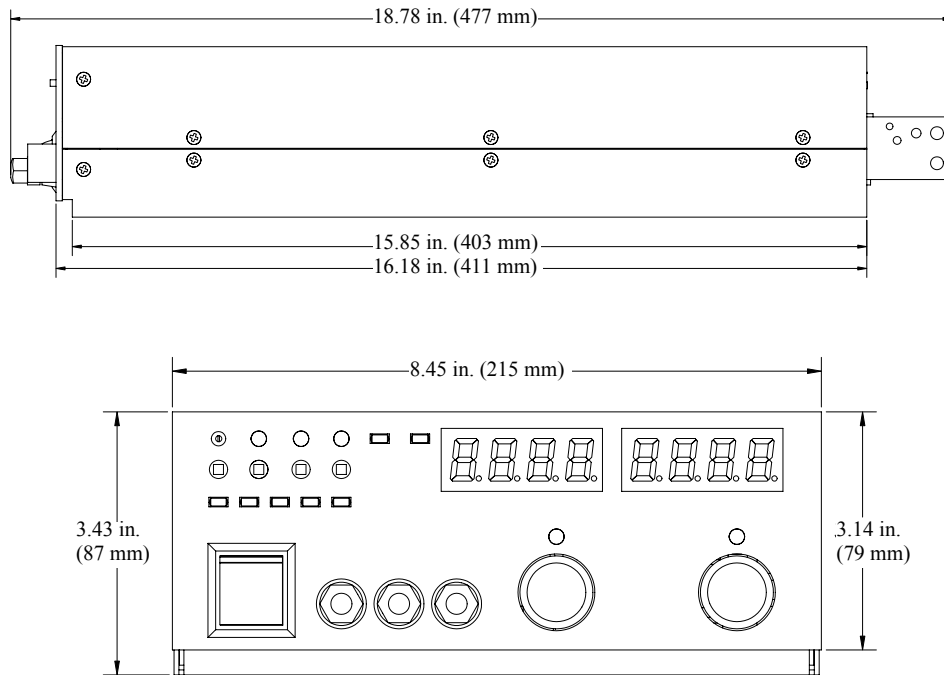

Figure 1.6 Dimensional Drawings
(Dimensions given are nominal.)

Section 2. Installation

Basic Setup Procedure

See [Table 2.1](#) for a summary of the basic setup procedure and an overall view of the information in this section. Use the procedure as a quick reference if you are familiar with the installation requirements for the power supply. If you want more information, each step in the procedure refers to sections which contain more details. Execute each step in the sequence given.

Table 2.1 Basic Setup Procedure

Step #	Description	Action	Reference
1	Inspection	Perform an initial physical inspection of the supply.	“Initial Inspection” on page 32
2	Installation	Install the supply (bench or rack mount); ensure adequate ventilation.	“Location, Mounting, and Ventilation” on page 35
3	Input Power	Connect AC input power.	“AC Input Power” on page 36
4	Test	Perform functional tests for voltage mode operation, current mode operation, and front panel controls.	“Functional Tests” on page 37
5	Load	Connect the load.	“Load Connection” on page 39
6	Sensing	Connect sensing lines.	“Local and Remote Sensing” on page 48

Inspection, Cleaning, and Packing

- Initial Inspection** When you first receive your unit, perform a quick physical check.
1. Ensure that each package contains the power supply and an AC input cord.
 2. Inspect the unit for scratches and cracks, and for broken switches, connectors, and displays.
 3. If you suspect internal damage, have a service technician check the unit.

If the unit is damaged, save all packing materials and notify the carrier immediately. See packing instructions in [“Packaging for Shipping or Storage”](#).

- Periodic Cleaning** No routine servicing of the power supply is required except for periodic cleaning. Whenever a unit is removed from operation, clean the metal surfaces with naphtha or an equivalent solvent and the front panel with a weak solution of soap and water. Use low pressure compressed air to blow dust from in and around components on the printed circuit boards.

Returning Power Supplies to the Manufacturer

Return Material Authorization Policy Before returning a product directly to Xantrex you must obtain a Return Material Authorization (RMA) number and the correct factory “Ship To” address. Products must also be shipped prepaid. Product shipments will be refused and returned at your expense if they are unauthorized, returned without an RMA number clearly marked on the outside of the shipping box, if they are shipped collect, or if they are shipped to the wrong location.

When you contact Xantrex to obtain service, please have your operating manual ready for reference and be prepared to supply:

- The serial number of your product
- Information about the installation and use of the unit
- Information about the failure and/or reason for the return
- A copy of your dated proof of purchase

When you ship:

1. Package the unit safely following the procedures on [page 34](#), preferably using the original box and packing materials. Please ensure that your product is shipped fully insured in the original packaging or equivalent. This warranty will not apply where the product is damaged due to improper packaging.
2. Include the following:
 - The RMA number supplied by Xantrex Technology Inc clearly marked on the outside of the box.
 - A return address where the unit can be shipped. Post office boxes are not acceptable.
 - A contact telephone number where you can be reached during work hours
 - A brief description of the problem

Ship the unit prepaid to the address provided by your Xantrex customer service representative.

If you are returning a product from outside of the USA or Canada:

In addition to the above, you MUST include return freight funds and are fully responsible for all documents, duties, tariffs, and deposits.

If you are returning a product to a Xantrex Authorized Service Center (ASC):

A Xantrex return material authorization (RMA) number is not required. However, you must contact the ASC prior to returning the product or presenting the unit to verify any return procedures that may apply to that particular facility.

Installation

Returning Power Supplies to the Manufacturer

Packaging for Shipping or Storage

Follow these instructions to prepare the unit for shipping or storage.

1. When returning the unit or sending it to the service center, attach a tag to the unit stating its model number (available from the front panel label) and its serial number (available from the rear panel label). Give the date of purchase and an invoice number, if you have it, as well as a brief description of the problem.
2. For storage or shipping, repack the power supply in its original container. If the original container is not available, seal the unit in a plastic bag and then pack it in a 200 lb. (90 kg) test, corrugated cardboard carton large enough to allow 2 inches (5 cm) of cushioning material to surround the unit. Use a material such as foam slabs or chips.
3. Label the carton as shown in [Figure 2.1](#).
4. If shipping, mark the address of the service center and your return address on the carton.
5. If storing, stack no more than eight cartons high. Check the storage temperature range and storage altitude specification in “Environmental Specifications” on page 28.

POWER SUPPLY
Model Number: _____
Serial Number: _____
FRAGILE — ELECTRONIC EQUIPMENT

Figure 2.1 Shipping or Storage Carton Label

Location, Mounting, and Ventilation

Rack Mounting



CAUTION

Ensure that any rack mounting screws do not extend more than 1/4in. (6.3 mm) into the base of the unit.

The rack mount kit allows you to mount two units side by side in a standard 19in. (483 mm) rack space.

1. Install commercially available rack slides, if used. Follow the manufacturer's instructions.
2. Remove the four (4) rubber feet from the bottom of each power supply.
3. Place the power supply (or supplies) into the rack mount pan (option RM3-XHR).
4. Screw four (4) #6-32 x 1/4in. flat head, rack mounting screws through the pan into the threaded holes on the bottom of each power supply.
5. Install the rack mount pan in the rack.

Ventilation Always ensure that cooling air reaches the ventilation inlet on the lower front of the unit and that the fan can exhaust from the rear of the unit. Additional ventilation space at the top and bottom of the supply will further lower internal operating temperatures.

Check "Environmental Specifications" for the specified operating ambient temperature range for the power supply.

AC Input Power



WARNING

There is a potential shock hazard if the power supply chassis and cover are not connected to an electrical ground via the safety ground in the AC input connector. Ensure that the power supply is connected to a grounded AC outlet with the recommended AC input connector configured for the available line voltage



CAUTION

When the power switch is turned on, the output voltage or current previously set will be applied to loads

We warrant that the unit will perform to specification at AC input voltage range from 85 to 250 Vac. The power output derates to 900 W when the AC input voltage is below 95 V.

AC Fail LED The AC Fail (ACF) LED turns on when the input voltage is outside of the range specified for the power supply. The LED turns off when the input voltage is within the range.

AC Input Cord We ship the power supply with an AC input cord rated for your location. See [Table 2.2](#) for the list of power cords that we ship. Use a power cord rated for your local voltage as long as it is within the supply's input range as stated in "Input Conditions" on page 26. Any cord that you use requires a standard IEC 320 termination to mate with the power supply's AC input connector. If you need a specific cord, call us.

Table 2.2 Power Cords

Location	Power Cord Rating
North America	125 V, 13 A NA plug
Asia	125 V, 13 A NA plug
Great Britain	250 V, 10 A British plug

Functional Tests

The functional test procedures include power-on and front panel function checks as well as voltage and current mode operation checks.

- Equipment Required**
- Digital voltmeter (DVM) rated better than 0.5% accuracy.
 - DC shunt 1 mV/A ($\pm 0.25\%$) with connecting wire. The recommended current ratings for the DC shunt and the wire must be at least 10% more than the output current of the power supply.

- Power-on Check**
1. Ensure that the AC power switch is in the OFF position.
 2. Ensure that the output sense lines are connected in the default configuration. On low voltage models, local sense jumpers connect terminal J2-2 on the J2 connector to the positive bus bar, and terminal J2-1 to the negative bus bar. On high-voltage models, terminal J2-2 connects to positive sense (+SNS) and terminal J2-1 to return sense (-SNS) on the wire clamp connector.
 3. Turn the voltage and current controls fully counter-clockwise.
 4. Connect the unit to an AC outlet.
 5. Turn the front panel power switch to ON.

After a short, power-on delay, the front panel digital meters light up. Both voltmeter and ammeter displays read zero.

- Voltage Mode Operation Check**
1. Ensure that both the voltage and current controls on the front panel are turned fully counter-clockwise.
 2. Connect the DVM to the output terminals on the rear panel, observing correct polarity.
 3. Turn the current control 1/2-turn clockwise.
 4. Slowly turn the voltage control clockwise and observe both the front panel voltmeter and the DVM. The voltage mode LED will turn on.
 5. Compare the DVM reading with the front panel voltmeter reading to verify the accuracy of the internal voltmeter. The minimum control range is from zero to the maximum rated output for the particular power supply model.
 6. Turn the front panel power switch to OFF.

Installation

Functional Tests

Current Mode Operation Check

1. Ensure that the front panel power switch is set to OFF.
2. Turn the voltage and current controls on the front panel fully counter-clockwise.
3. Turn the voltage control one (1) or two (2) turns clockwise.
4. Connect a DC shunt across the output terminals on the rear panel.
5. Connect a DVM across the DC shunt. The DC shunt-DVM combination must be rated better than 0.5% accuracy.
6. Turn the power switch to ON.
7. Slowly turn the current control clockwise. The current mode LED will turn on.
8. Compare the DVM reading with the front panel ammeter reading using $I=V/R$ where V is the DVM reading and R is the DC shunt resistance. The control range is from zero to the maximum rated output for the power supply model.
9. Turn the power switch to OFF.
10. Disconnect the DVM and the shunt.

Front Panel Function Check

1. Turn the power switch to ON.
2. Set the voltage and current controls fully clockwise. Push the STANDBY switch to its IN position and check that the voltmeter reading falls to zero and the S/D (Shutdown) LED turns on. Push the STANDBY switch once again to reset it to its OUT position. The S/D LED turns off.
3. Press the STANDBY switch to the IN position.
4. Press the OVP CHECK switch. Check that the voltmeter displays approximately the model-rated output voltage plus 10%.
5. Turn the OVP SET potentiometer counter-clockwise and check that the voltmeter reading decreases. Continued turning (up to 20 turns) will see the reading decrease to approximately 5% of the model-rated voltage output. Turn the OVP SET potentiometer clockwise until the voltmeter once again displays approximately the model rated output voltage plus 10%.
6. Press the STANDBY switch to its OUT position.
7. Make sure the voltage and current controls are turned all the way in the clockwise direction. Press the V/I CHECK switch and check that the voltmeter and ammeter display a minimum of the power supply model output ratings.
8. Turn the power switch to OFF.

Load Connection

This section provides recommendations for load wires and how to connect them for both single and multiple load configurations.

Load Wiring When connecting load wiring to the power supply, consider the following factors:

- Current capacity and voltage rating of the wire
- Maximum load wiring length for operation with sense lines
- Noise and impedance effects of the load lines

Insulation Rating



WARNING

There is a potential shock hazard at the output when using a power supply with a rated output greater than 40 V. Use load wiring with a minimum insulation rating equivalent to the maximum output voltage of the power supply. For example, select TEW-105, 105 °C, 600 V wiring for use with a 600 V, 1.7 A power supply.

Current Capacity As a minimum requirement, load wiring must have a current capacity greater than the output current rating of the power supply. This ensures that the wiring will not be damaged even if the load is shorted. [Table 2.3](#) shows the maximum current rating, based on 450 A/cm², for various gauges of wire rated for 105 °C operation. Operating at the maximum current rating results in an approximate 30 °C temperature rise for a wire operating in free air. Where load wiring must operate in areas with elevated ambient temperatures or bundled with other wiring, use larger gauges or wiring rated for higher temperatures.

Table 2.3 Current Carrying Capacity for Wiring

Wire Size (AWG)	Maximum Current (A)	Wire Size (AWG)	Maximum Current (A)
18	4	8	36
16	6	6	61
14	10	4	97
12	16	2	155
10	21		

Installation
Load Connection

Load Wiring Length for Operation with Sense Lines For applications using remote sensing, you must limit the voltage drop across each load line. [Figure 2.2](#) shows some maximum allowable wire lengths for a given load current and wire size. We recommend that you use the larger load wiring to ensure a smaller voltage drop (1 V typical maximum), although the units (except 7.5 V models) will compensate for up to 5 V drop in each line. See also [“Local and Remote Sensing”](#) on page 48.

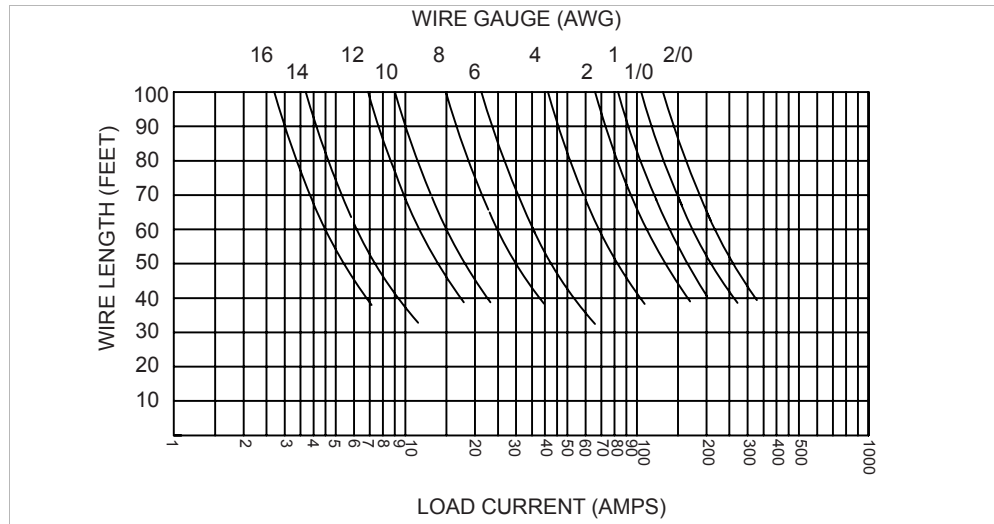

Figure 2.2 Maximum Load Wire Length for 1 V Line Drop

Noise and Impedance Effects To minimize noise pickup and radiation, use shielded pair wiring of shortest possible length for load wires. Connect the shield to the chassis using the ground screw on the rear panel. Where shielding is impossible or impractical, simply twisting the wires together will offer some noise immunity. When using local sense connections, use the largest practical wire size to minimize the effects of load line impedance on the regulation of the supply.

Making Load Connections



WARNING

There is a potential shock hazard at the load when using a power supply with a rated output greater than 40 V. To protect personnel against accidental contact with hazardous voltages, ensure that the load, including connections, has no live parts which are accessible. Also ensure that the insulation rating of the load wiring and circuitry is greater than or equal to the maximum output voltage of the power supply.

Make load connections to the power supply at output connectors at the rear of the power supply, or at the binding posts on the front panel.

Binding Posts (All Models) The binding posts on the front panel have a built-in current limiting function which will not allow more than 30 A to be drawn from the output on units with high output current capability. If the draw exceeds 30 A, the Binding Post Overload (OL) LED on the front panel lights up and the current draw is limited to 30 A. Once the load draw drops below 30 A, the OL LED goes out and normal operation resumes. Use remote sensing to improve load regulation at the binding posts. See “Specifications” on page 23 for any differences in specifications when operating with the load connected at the binding posts.

7.5 V to 40 V Models



CAUTION

Do not remove the A16 EMI filter board or the bus bar capacitor from the bus bars. Operating the power supply without the EMI filter board or the bus bar capacitor will impair its electrical performance.



CAUTION

When making connections to the bus bars, ensure each terminal's mounting hardware and wiring assembly are placed to avoid touching the other terminal and shorting the power supply output. Heavy connecting cables must have some form of strain relief to avoid loosening the connections or bending the bus bars.

The 7.5 V to 40 V models have output bus bars on the rear panel and come with a bus bar shield. A filter capacitor and the A16 EMI filter board are attached to the bus bars on the rear panel. Detach only the bus bar shield before making load or remote sense line connections. To detach the shield, remove the screws as shown in [Figure 2.3](#).

Installation
Load Connection

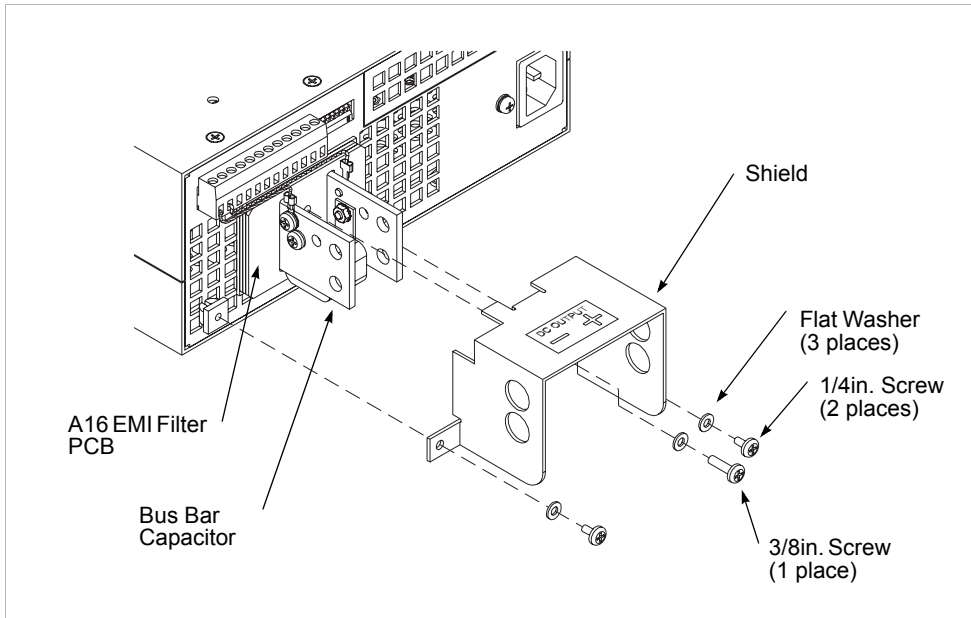

Figure 2.3 Bus Bar Shield

Inductive Loads

Use the following protection methods only when using local sensing.

To prevent damage to the power supply from inductive kickback, connect a diode across the output. The diode must be rated at greater than or equal to the supply's output voltage and have a current surge rating greater than or equal to the supply's output rating. Connect the cathode to the positive output and the anode to the return.

Where positive load transients such as back EMF from a motor may occur, connect a transorb or a varistor across the output to protect the power supply. The breakdown voltage rating for the transorb or varistor must be approximately 10% higher than the rated supply output.

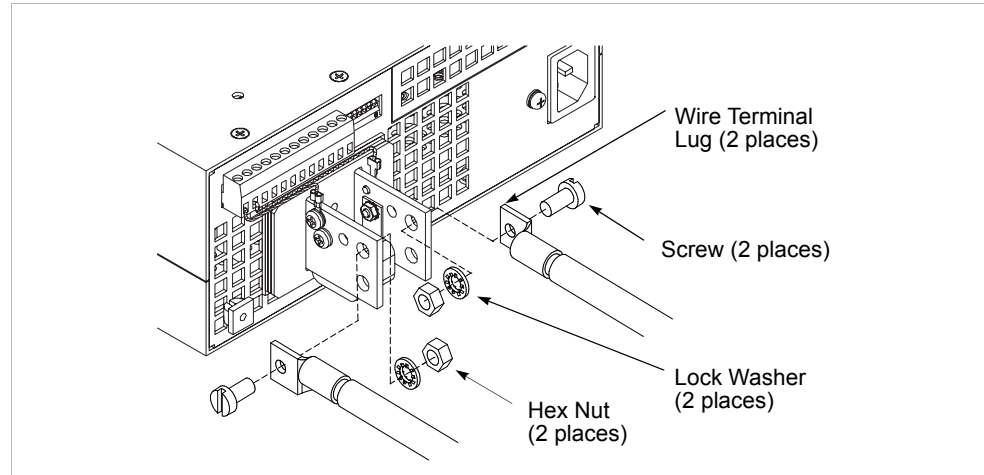

Figure 2.4 Typical Load Connection Hardware
(For 7.5 V to 40 V models.)

To make load connections to a 7.5 V, 130 A power supply:

1. Install a connecting wire terminal lug to load wiring. See [Figure 2.4](#).
2. Fasten wire terminal lugs to bus bars with 1/4in. x 1/2in. (M6 x 12 mm) screws, 1/4in. (M6) internal tooth lock washers, and hex nuts as shown.

Note: Bus bar hole sizes are: 2 of 0.257in. (6.50 mm) diameter (D); 1 of 0.191in. (4.83 mm) D; and 2 of 0.156in. (3.95 mm) D.

Installation
Load Connection

60 V to 600 V Models



WARNING

To protect personnel against accidental contact with hazardous voltages, ensure that the load, including connections, has no live parts which are accessible. Also ensure that the insulation rating of the load wiring and circuitry is greater than or equal to the maximum output voltage of the power supply.

The output connector for the 60 V to 600 V models is a 4-terminal, wire clamp connector located on the rear panel. Two of the terminals are for local sense connections. See [Figure 2.5](#).

To prepare and connect the load wiring:

1. Strip insulation 0.35in. (9 mm) at the end of the wires.
2. Loosen the terminal screw, insert the stripped wire into the terminal, and tighten the screw securely.

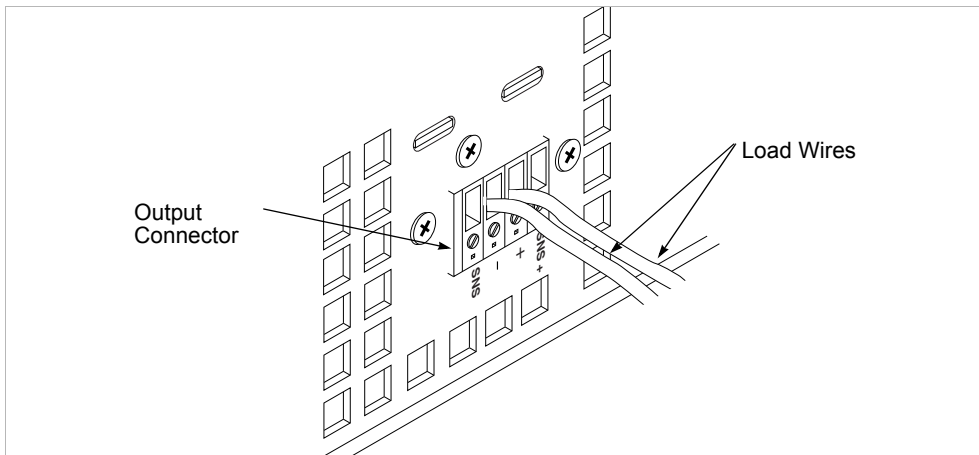

Figure 2.5 Output Connector
(For 60 V to 600 V models.)

Connecting Single Loads

Figure 2.6 and Figure 2.7 show recommended load and sensing connections for single loads. Local sense lines shown are default J2 connections.

You do not need remote sensing for basic operation of your supply. However, if you wish to correct for any small drops in your load lines, then use this feature. Refer to [Using Remote Sensing](#) for more information.

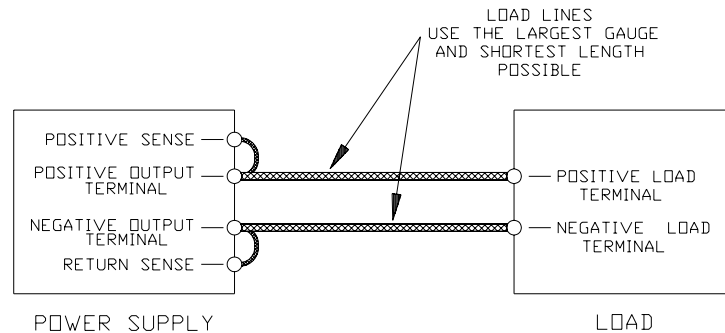

Figure 2.6 Single Load with Local Sensing (Default)

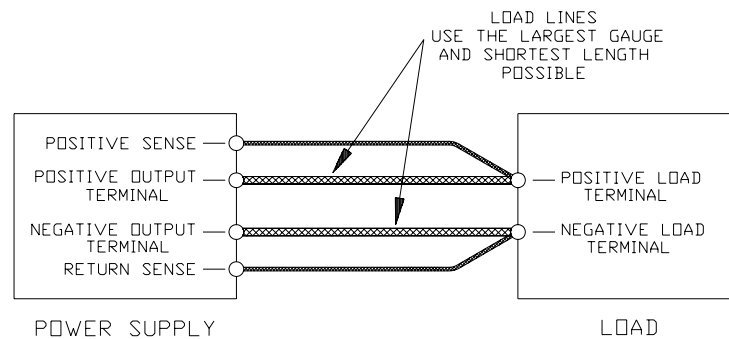

Figure 2.7 Single Load with Remote Sensing

Connecting Multiple Loads

Proper connection of distributed loads is an important aspect of power supply use. Two common methods of connection are the parallel power distribution method and the radial power distribution method.

Parallel Power Distribution This distribution method involves connecting leads from the power supply to one load, from that load to the next load, and so on for each load in the system. This method results in the voltage at each load depending on the current drawn by the other loads and allows DC ground loops to develop. Except for low current applications, we do not recommend using this method.

Installation
Load Connection

Radial Power Distribution Method To connect distributed loads, we recommend that you use radial power distribution. With this method, you connect power to each load individually from a single pair of terminals designated as the positive and negative distribution terminals. These terminals may be the power supply output terminals, the terminals of one of the loads, or a distinct set of terminals especially established for distribution use. Connect the sense leads to these terminals to compensate for losses and minimize the effect of one load upon another.

Figure 2.8 and Figure 2.9 show recommended load and sensing connections for multiple loads. Local sense lines shown are default J2 connections. Refer to [Using Remote Sensing](#) for how to ground the sense line shield.

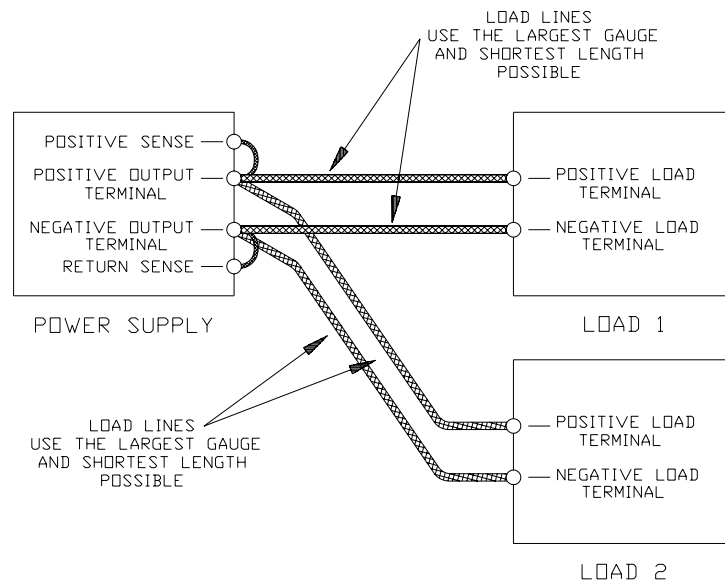

Figure 2.8 Multiple Loads with Local Sensing

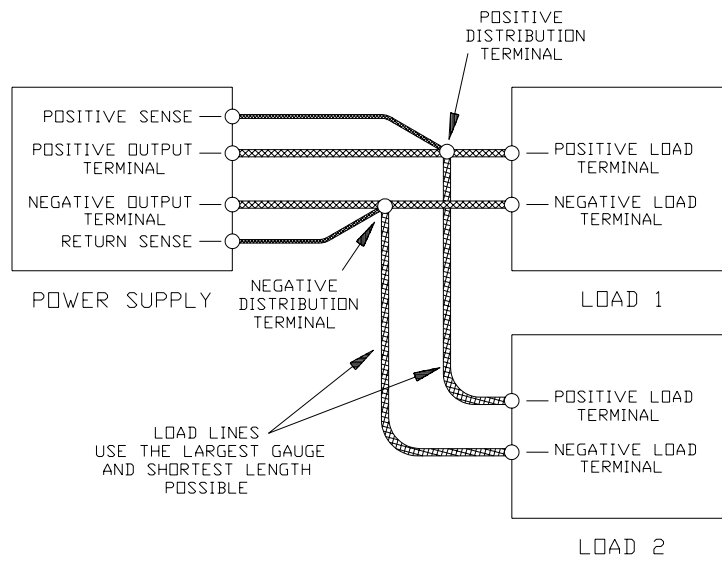

Figure 2.9 Multiple Loads with Remote Sensing

Installation

Local and Remote Sensing

Local and Remote Sensing

Use connections on the rear panel J2 connector to set up the power supply for local or remote sensing of output voltage.

Sense Wiring



WARNING

There is a potential shock hazard at the sense connector when using a power supply with a rated output greater than 40 V. Select wiring with a minimum insulation rating equivalent to the maximum output voltage of the power supply for use as local sense jumpers or for remote sense wires. For example, select TEW-105, 105 °C, 600 V wiring for use with a 600 V, 1.7 A power supply. Ensure that connections at the load end are shielded to prevent contact with hazardous voltages.

Local Sensing

We ship the power supply with wire jumpers installed for local sensing of the output. See “Rear Panel Illustrations” on page 18. With local sensing, the output voltage is regulated at the output terminals. This method does not compensate for voltage losses in the load lines, so it is recommended only for low current applications or for applications in which load regulation is not essential.

Note: When using local sense connections, use the largest practical wire size to minimize the effects of load line impedance on the regulation of the supply.

Using Remote Sensing



WARNING

There is a potential shock hazard at the sense points when using a power supply with a rated output greater than 40 V. Ensure that connections at the load end are shielded to prevent contact with hazardous voltages.



CAUTION

Do not use remote sensing with multiple supplies connected in series.

Note: Ground the sense line shield in one place only. Locations include: the power supply’s return output connection at the load, the power supply’s return output at its negative output terminal, or the power supply’s chassis.

Use remote sensing during voltage mode operation to shift the power supply's regulation point from its output terminals to the load or distribution terminals by using a separate pair of wires to allow the control circuitry to monitor the load voltage. This allows the power supply to compensate for voltage losses in the load lines which would otherwise degrade the regulation of the supply. Line drop is subtracted from the total voltage available at the output. You can also use remote sensing to improve load regulation at the front panel binding posts.

To connect remote sense lines:

1. Turn the power supply OFF.
2. Remove the local sense jumper connecting J2 terminal 2 to the positive bus bar (or positive sense on wire clamp output connector). Remove the local sense jumper connecting J2 terminal 1 to the negative bus bar (or negative or return sense on wire clamp output connector).
3. Connect the positive remote sense lead to J2 terminal 2 (positive sense) and the negative lead to J2 terminal 1 (return sense). Use shielded pair wiring of 24 AWG or larger for remote sense lines. Ensure the mating J2 connector is plugged securely into the connector at the rear panel. Connect the other ends of the sense wires to the corresponding sense points at the load.
4. To prevent ground loops, ground the sense line shield, at one point only, to the power supply's return output connection at the load, to the power supply's return output at its output terminal, or to the power supply's chassis. See [Figure 2.10](#) for an example.
5. Turn the power supply ON.

Notes:

- If you operate the power supply with remote sense lines connected to the load and with either of the positive or negative load lines not connected, the power supply shutdown circuit will activate, causing the output voltage and current to fall to zero.
- If you operate the power supply without remote sense lines or local sense jumpers in place, the supply will continue to function, but supply regulation will be degraded and/or erratic, or the OVP circuit may activate.

Installation
Local and Remote Sensing

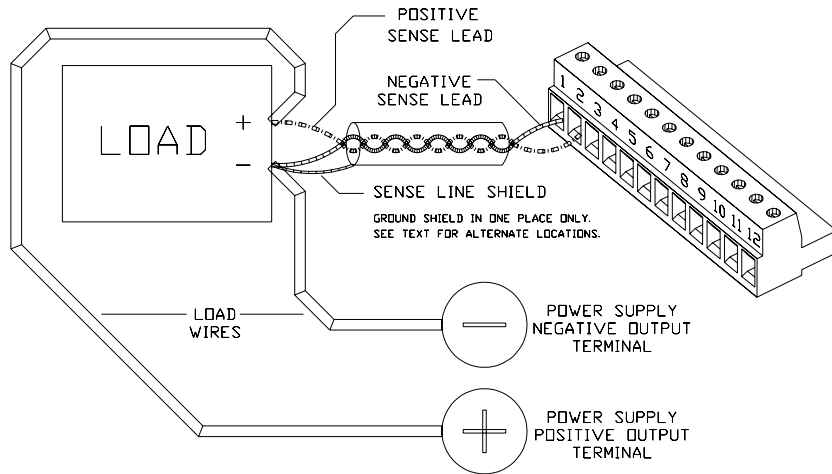

Figure 2.10 Connecting Remote Sense Lines

Section 3. Local Operation

Standard Operation

Once you have installed the power supply as covered in Section 2. Installation, the power supply is ready to operate in local control mode (that is, operation at the front panel). The power supply has two basic operating modes: Constant Voltage Mode and Constant Current Mode, and two control modes: Local Control Mode (default setting) and Remote Programming Mode.

Operating Modes and Automatic Crossover

Whether controlled by local or remote programming, the power supply has two basic operating modes: Constant Voltage Mode and Constant Current Mode. The mode in which the power supply operates at any given time depends on the combination of:

- output voltage setting V_{SET}
- output current limit setting I_{SET}
- resistance of the attached load R_L

Figure 3.1 provides a graphical representation of the relationships between these variables.

Local Operation
Standard Operation

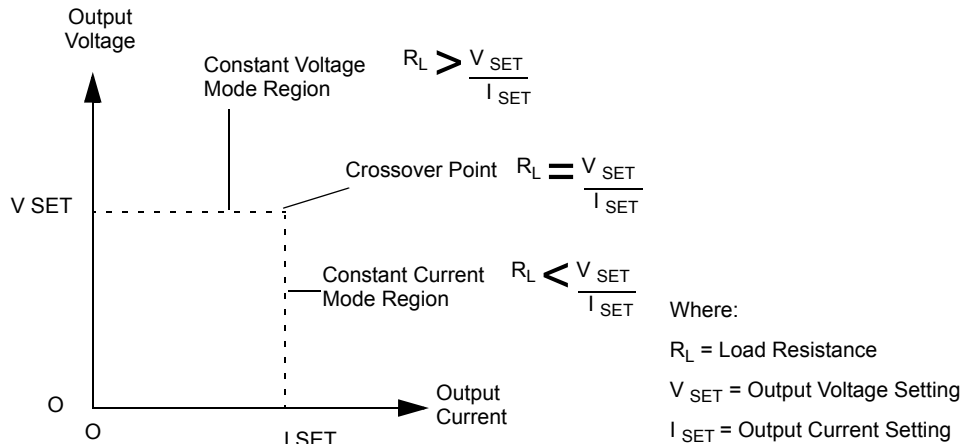

Figure 3.1 Operating Modes

Constant Voltage Mode Operation The power supply will operate in constant voltage mode whenever the load current I_L is less than the current limit setting I_{SET} , or: $I_L < I_{SET}$ (Note: $I_L = V_{SET} / R_L$).

In constant voltage mode, the power supply maintains the output voltage at the selected value (V_{SET}) while the load current I_L varies with the load requirements.

Constant Current Mode Operation The power supply will operate in constant current mode whenever the load resistance is low enough that the load current I_L is equal to the current limit setting I_{SET} (Note: $V_L = I_{SET} R_L$).

In constant current mode, the power supply maintains the output current at the selected value (I_{SET}) while the load voltage varies with the load requirements.

Automatic Mode Crossover This feature allows the power supply to automatically switch operating modes in response to changing load requirements. If, for example, the power supply was operating in Constant Voltage Mode ($I_L < I_{SET}$), and the load changed so that the load current (I_L) became equal to the current limit setting (I_{SET}), the power supply would automatically switch into Constant Current Mode and the output voltage would vary in response to changes in load current. If the additional load was subsequently removed so that the load current was again less than the current limit setting, the supply would automatically return to Constant Voltage Mode.

Shipped Configuration (Local Control Mode)

The factory ships units already configured for local control (front panel) operation. [Table 3.1](#) summarizes this configuration.

Table 3.1 Shipped Configuration (Local Control Mode)

Local Control Configuration	Additional References
Use the front panel controls to adjust the output voltage and current limit settings. (Note: You can use the LOCAL button only when you have a digital programming interface installed.)	Section 3 covers front panel operation. See Section 4 for how to set up for remote analog programming.
The supply's sense point is at the rear panel output connector terminals.	See “Local and Remote Sensing” on page 48 for how to change from local to remote sensing.
The over voltage protection (OVP) set point is adjusted at the front panel to approximately 110% of rated output voltage.	See “Using Over Voltage Protection (OVP)” on page 59 for how to change the OVP setpoint.
The over temperature shutdown function automatically resets when activated as determined by the position of rear panel switch SW1-8. A latch off setting is also available.	See “Over Temperature Protection (OTP)” on page 63 for more information about switch SW1-8 settings for OTP recovery.

Setting Output Voltage and Current Limit

Install the power supply and connect the load as described in [Section 2](#). Ensure that the power supply is set for local control as described in [“Shipped Configuration \(Local Control Mode\)”](#) on page 53. Then, set the output voltage and current limit at the front panel with the following procedure.

1. Turn both the voltage and current controls fully counter-clockwise.
2. Turn the power ON.
3. Press the STANDBY switch to its IN position to disable the power supply output.
4. Press and hold the V/I CHECK button to display the voltage and current control settings on the voltmeter and ammeter displays.
5. Adjust the voltage control to the desired voltage (the compliance voltage for applications using current mode operation).
6. Adjust the current control to the desired current limit setting.
7. Release the V/I CHECK button.
8. Press the STANDBY switch to its OUT position to apply power to the load.

Note: The control circuits have been designed to allow you to set output voltage and current up to 5% over the model-rated maximum values. The power supply will operate within these extended ranges, but we cannot guarantee full performance to specification.

Local Operation

Using Multiple Supplies

Using Multiple Supplies



WARNING

There is a shock hazard at the load when using a power supply with a rated *or combined* output greater than 40 V. To protect personnel against accidental contact with hazardous voltages created by series connection, ensure that the load, including connections, has no live parts which are accessible. Also ensure that the insulation rating of the load wiring and circuitry is greater than or equal to the maximum output voltage of the power supply.



CAUTION

Do not connect power supplies from different manufacturers in parallel or in series.



CAUTION

The remote programming inputs are internally referenced to the power supply's negative output. Do not connect remote programming ground lines (J2 terminals 3 and 6) to the supply's positive output.

You can operate power supplies of the same model with outputs in series or in parallel to obtain increased load voltage or increased current. Split supply operation gives you two positive outputs or a positive and a negative output.

Note: If your application requires the use of isolated programming inputs, contact the manufacturer about the optional ISOL interface.

Configuring Multiple Supplies for Series Operation



CAUTION
Do not use remote sensing during series operation.



CAUTION
The maximum allowable sum of the output voltages is 600 Vdc.

Use series operation to obtain a single higher voltage output using two or more supplies. Connect the negative (-) output terminal of one supply to the positive (+) output terminal of the next supply. See [Figure 3.2](#). The total voltage available is the sum of the maximum voltages of each supply (add voltmeter readings) to a maximum of 600 V. The maximum allowable current for a series string of power supplies is the output current of a single supply in the string.

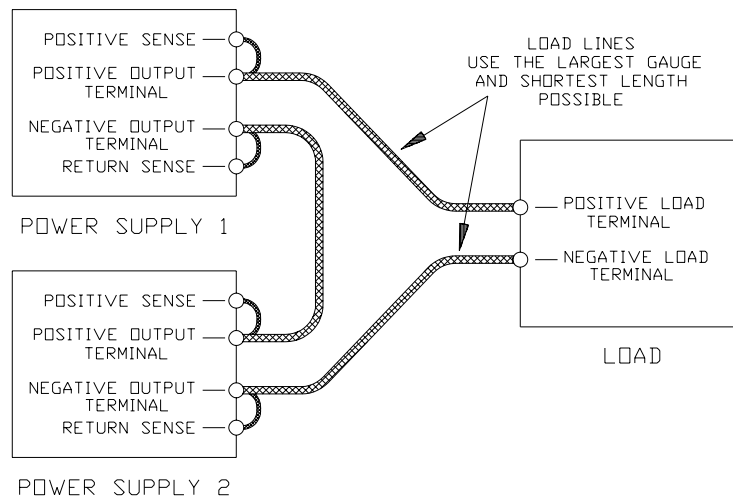

Figure 3.2 Series Operation of Multiple Supplies

Local Operation

Using Multiple Supplies

Configuring Multiple Supplies for Parallel Operation

Use parallel operation to obtain a higher current through a single output using two or more supplies. Set all of the OVP set points to maximum. Set all of the outputs to the same voltage before connecting the positive (+) output terminals and negative (-) output terminals in parallel. See [Figure 3.3](#). The total current available is the sum of the maximum currents of each supply.

When operating multiple supplies in parallel, the operating mode of each supply depends on the load current being drawn. For example, with two 20 V, 50 A power supplies operating in parallel with a 75 A load, one supply operates in constant current mode supplying 50 A and the other supply operates in voltage mode supplying the remaining 25 A. The level of current sharing between units depends on how accurately the output voltages are matched.

Note: If you do not fix the OVP setpoints at maximum, the OVP circuit may trip on one unit, reducing the current available to the load.

Sensing for Parallel Operation Use default local sensing to enhance power sharing between units, as the impedance of the load lines will tend to correct for current imbalance. If you use remote sensing at the load for better voltage regulation, one supply always operates in current limit mode and supplies most of the power.

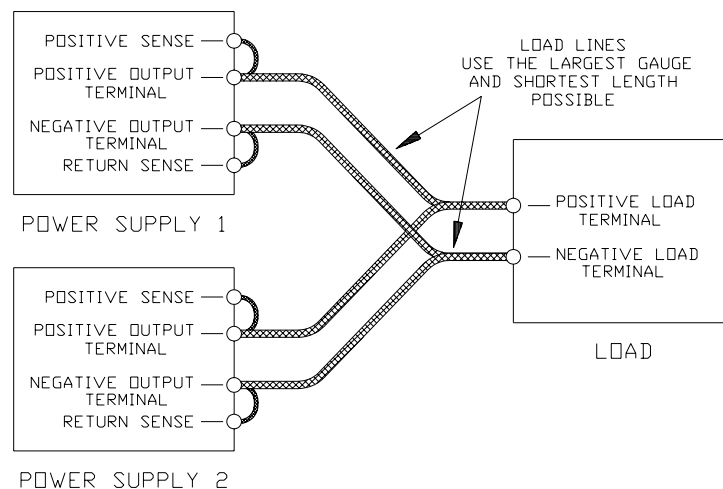

Figure 3.3 Parallel Operation of Multiple Supplies
(Local sense lines shown are default J2 connections.)

Configuring Multiple Supplies for Split Supply Operation

Split supply operation uses two power supplies to obtain two positive voltages with a common ground, or to obtain a positive-negative supply.

Two Positive Voltages To obtain two positive voltages, connect the negative output terminals of both supplies together in a common connection. The positive output terminals will provide the required voltages with respect to the common connection. See [Figure 3.4](#).

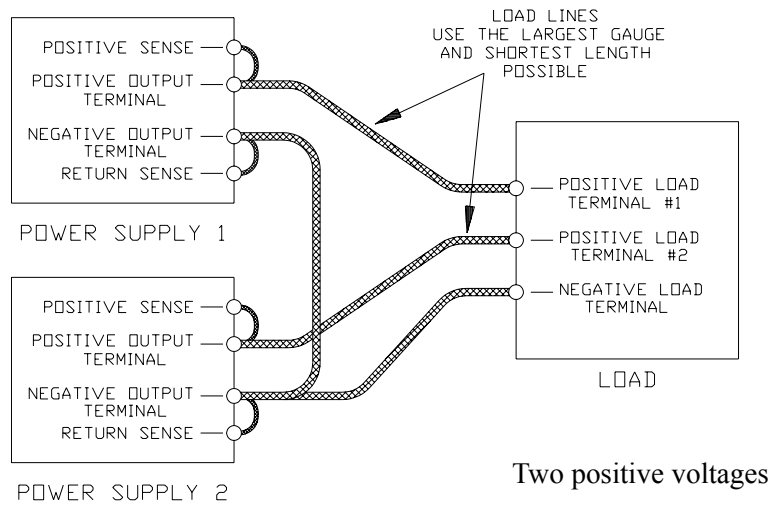

Figure 3.4 Split Supply Operation of Multiple Supplies
(Local sense lines shown are default J2 connections.)

Local Operation
Using Multiple Supplies

Positive-negative Supply

CAUTION To prevent possible damage to the supply, do not connect the remote program return line of the negative supply to the common connection.

To obtain a positive-negative supply, connect the negative output terminal of one supply to the positive output terminal of the second supply. See [Figure 3.5](#). The positive output terminal of the first supply now provides a positive voltage relative to the common connection. The negative output terminal of the second supply provides the negative voltage. You can set the current limits independently. The maximum current available in split supply operation is equal to the rated output of the supplies.

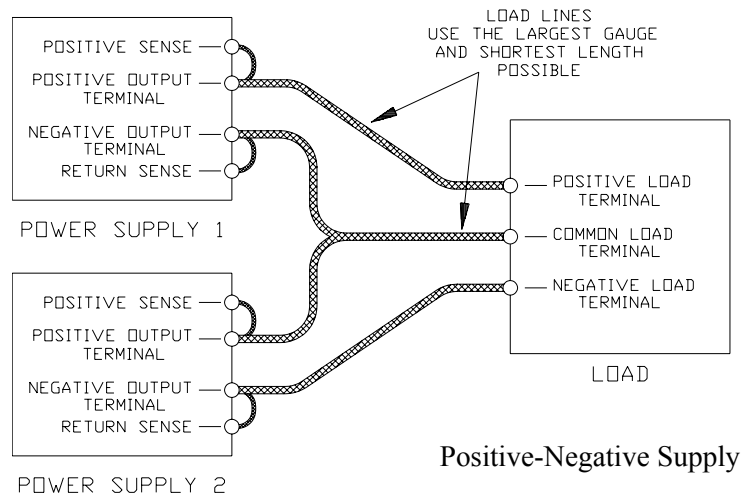

Figure 3.5 Split Supply Operation of Multiple Supplies
(Local sense lines shown are default J2 connections.)

Using Over Voltage Protection (OVP)

The OVP circuit protects the load in the event of a remote programming error, an incorrect voltage control adjustment, or a power supply failure. The protection circuit monitors the output voltage and will shut down the main power converter whenever a preset voltage limit is exceeded. Set the preset voltage limit (also called the set point or trip level) using the screwdriver-adjustable potentiometer on the front panel or via one of the optional GPIB or RS-232 programming interfaces.

Notes:

- The default preset limit is approximately 110% of the rated output voltage.
- When using OVP with remote sensing lines connected, compensate for the voltage line drop across the output return line by measuring or calculating the line drop, then adding this value to the desired OVP setpoint.

Front Panel OVP Operation

In local control mode, check the OVP set point at any time by pressing the OVP CHECK switch. The OVP set point is the value displayed on the digital voltmeter.

To set the trip level from the front panel:

1. Disconnect any loads. Turn the power supply ON.
2. Adjust the power supply voltage to any voltage lower than the desired trip level.
3. Press the front panel STANDBY (output shutdown) switch to its IN position.
4. Press the OVP CHECK switch to observe the OVP set point on the voltmeter display.
5. Holding down the OVP CHECK switch, turn the OVP SET potentiometer until the desired set point is reached. Release the OVP CHECK switch.
6. Release the STANDBY switch to its OUT position. The S/D LED turns OFF.
7. To check that the power supply shuts off at the desired set point, slowly increase the output voltage while monitoring the front panel voltmeter. The OVP LED on the front panel will turn on when the OVP circuit activates.

Local Operation

Using Over Voltage Protection (OVP)

Resetting the OVP Circuit

To reset the OVP circuit after it activates:

1. Reduce the power supply's output voltage setting to below the OVP set point.
2. Press the STANDBY switch IN. The S/D (Shutdown) LED on the front panel will turn on. The OVP LED turns off.
3. Press the STANDBY switch again to return power to the load and resume normal operation.

OR

1. Reduce the power supply's output voltage setting to below the OVP set point.
2. Turn the power supply OFF using the power switch, wait until the front panel displays go out, then turn the supply back ON again.

Using the Shutdown Function

Use the Shutdown function to disable or enable the supply's output so that you can make adjustments to either the load or the power supply without shutting off the entire supply. Activate this function from the front panel at any time by using the STANDBY switch. You can also activate it via remote control through the rear panel J2 connector, using a 2.5 V to 15 V signal or a transistor-transistor logic (TTL) compatible input. The input lines for the Shutdown circuit are optically isolated.

STANDBY Switch The STANDBY switch is a press-button switch located on the power supply's front panel. Pushing the switch to its IN position activates the Shutdown circuit. The output voltage and current drop to zero and the S/D (shutdown) LED turns on. Pushing the switch to its OUT position returns the power supply to normal operation.

Controlling the Shutdown Function via the J2 Connector The Shutdown circuit accepts a 2.5 V to 15 V signal to disable or enable the power supply's output. Make connections for signals at connector J2, located on the unit's rear panel. Set rear panel switch SW1-7 to select signal logic. See Section 1 for more information about making J2 connector or SW1 switch changes.

To activate the Shutdown function:

1. Turn the power supply OFF.
2. Connect the signal source to J2 connector terminal 11 (Shutdown Input/positive) and terminal 12 (Shutdown Return).
3. Set switch SW1-7 to select the desired circuit logic as set out in [Table 3.2](#).
4. Turn on the power supply.

The power supply will operate as described in [Table 3.2](#) according to the logic you select and the level of the input signal you provide. The S/D LED on the front panel turns on when the Shutdown circuit is activated.

Table 3.2 Switch Settings for Shutdown Circuit Logic

Switch SW1-7 Setting	Source Signal	Signal Level	Supply Output	S/D LED
OFF (OPEN) (Active low, default)	2-15 V	HIGH	OFF	ON
	0-0.4 V	LOW	ON	OFF
ON (CLOSED) (Active high)	2-15 V	HIGH	ON	OFF
	0-0.4 V	LOW	OFF	ON

Note: If switch SW1-7 is set to ON but there is no signal applied, the S/D LED turns on and the power supply will not provide an output until the HIGH signal level is applied.

Local Operation

Using the Shutdown Function

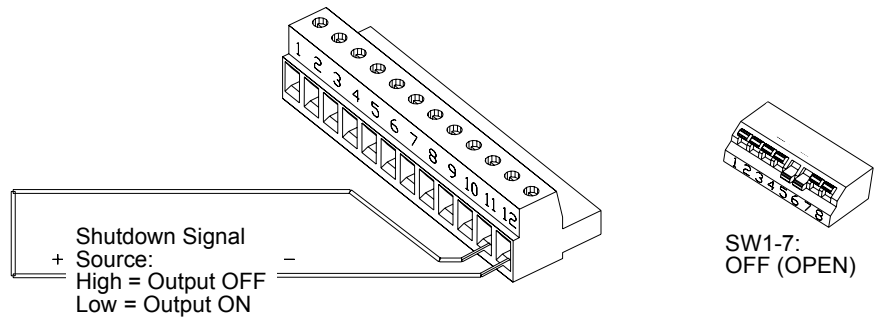

Figure 3.6 Shutdown Programming with Active Low Signal

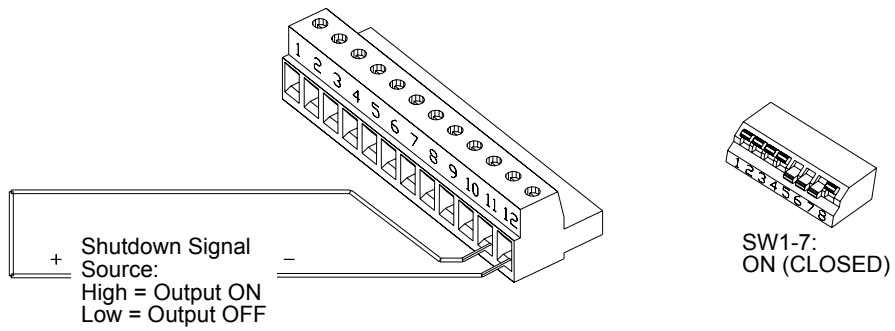

Figure 3.7 Shutdown Programming with Active High Signal

Over Temperature Protection (OTP)

The over temperature protection circuit shuts down the power supply's output when the power supply exceeds internal temperature limits. When an OTP shutdown occurs, the OTP LED on the front panel turns on. You can select the way that the power supply recovers from an over temperature shutdown by setting the SW1-8 switch on the rear panel. [Table 3.3](#) shows the possible switch settings.

Table 3.3 Switch Settings for Over Temperature Recovery Options

Switch SW1-8	OTP Shutdown Selection	Description
OFF (OPEN)	Auto Reset (Default)	The supply recovers to normal operation when the over temperature condition no longer exists.
ON (CLOSED)	Latch OFF	After an over temperature shutdown, the supply stays OFF until you cycle its input power using the front panel AC power switch.

User Diagnostics

If your power supply is not performing as described in this manual, run through the procedures and checks in this section before calling your service technician. These procedures are confined to operator-level functions only and do not require cover-off servicing.

Emergency Shutdown In an emergency, carry out both of these steps:

1. Shut the power supply off immediately.
2. Disconnect the power supply from the load.

Unusual or Erratic Operation If the power supply displays any unusual or erratic operation, follow these steps:

1. Shut the power supply off immediately.
2. Disconnect the power supply from the load.
3. Test the power supply with no load, running the tests in “Functional Tests” on page 37.
4. If the tests show that the power supply is functioning normally, check that load, programming, and monitoring connections and circuits.
5. Check the AC input for correct voltage and frequency.

If the problem is not solved by following this procedure, or if the unit fails to operate correctly upon retesting, call your service technician.

Troubleshooting for Operators Use the checks in [Table 3.4, “Quick Diagnostics”](#) to ensure that the power supply is configured and connected for normal operation. If you require further troubleshooting, call your service technician.

Abbreviated References Used in Table

ACF	AC Fail
OTP	over temperature protection
OVP	over voltage protection
REM	remote mode
S/D	shutdown

Table 3.4 Quick Diagnostics

Symptom	Check	Further Checks and Corrections
No output and the display is blank.	Is input voltage in the specified range?	Connect to appropriate voltage source.
	Power switch ON?	Turn on power.
	Internal circuit.	See your service technician.
No output but the display turns on.	SW1 switch settings correct? (For when using analog programming.)	See “Remote Analog Programming of Output Voltage and Current Limit” on page 67.
	OVP LED turned on?	See “Using Over Voltage Protection (OVP)” on page 59.
	Front panel S/D LED turned on?	See “Using the Shutdown Function” on page 61.
	OTP LED turned on?	See “Over Temperature Protection (OTP)” on page 63.
	Current limit set to zero?	See “Standard Operation” on page 51.
	Voltage control set to zero?	See “Standard Operation” on page 51.
	REM LED turned on?	If using remote analog control, check your analog programming source. (See “Remote Analog Programming of Output Voltage and Current Limit” on page 67.) If not, refer to your digital interface manual.
	Is front panel ACF LED turned on?	Connect unit to AC supply in specified range.
No output and display blinks dimly.	Internal circuit.	See your service technician.
	Internal circuit.	See your service technician.
Output not adjustable.	Is unit in current limit mode? (Red Current Mode LED turned on).	Turn current knob clockwise to increase current limit. Reduce load if current is at maximum. See “Operating Modes and Automatic Crossover” on page 51.
	Is unit in remote mode? (Green REM LED turned on).	If using remote analog control, check your analog programming source. (See “Remote Analog Programming of Output Voltage and Current Limit” on page 67.) If not, refer to your digital interface manual.
	Is unit at maximum voltage or current limit?	Reduce load for lower voltage or current requirement.

Local Operation

User Diagnostics

Symptom	Check	Further Checks and Corrections
Output voltage fluctuating or regulation poor.	Is unit at current limit?	Increase current limit setting or reduce load. See “Standard Operation” on page 51 .
	Is input voltage within specified range?	Connect to appropriate AC voltage source.
	Are sense lines connected?	See “Load Connection” on page 39 and “Local and Remote Sensing” on page 48 .
	Is unit under remote control? Internal circuit.	Ensure program source is stable. See your service technician.
Output oscillating.	Check for unstable or oscillating programming source.	Stabilize programming source connected to J2.
	Peak current drawn by load exceeds current limit setting of supply (motors, switchmode loads).	Add external supply capacitance to supply output.
	Internal circuit.	See your service technician.

Section 4. Remote Operation

Remote Analog Programming of Output Voltage and Current Limit



CAUTION

Ensure that you make connections to the J2 connector exactly as shown in each procedure in this section. Incorrect J2 jumper connections may damage the supply.

Remote analog programming allows control of the output voltage and/or current limit to shift from local operation at the front panel controls to external analog sources. As you vary the external programming source, the power supply's output varies proportionally over its output range.

Using remote analog programming requires that you reset switches and make connections to a connector on the rear panel. See Section 1. Features and Specifications for information about using the rear panel switch and connector.

Remote Programming Options

Remote analog programming allows control of both output voltage and the current limit. You have a choice of programming scales depending on your choice of voltage source and resistance. You can choose a voltage source of 0-5 V or 0-10 V or a current source using a resistance of 0-5 k or 0-10 k. You can use the programming scales in any combination to suit your needs.

Isolated Programming The 4-channel Isolated (ISOL) Programming Interface is an internal board which can be ordered as an option. It allows remote programming and readback of the power supply's output voltage and current limit with 0-5 V analog signals at a different voltage potential relative to the power supply's output. The ISOL interface is described in [“Using the Isolated Programming \(ISOL\) Interface Option” on page 72.](#)

Remote Digital Programming You can operate the power supply from a computer if you have had the GPIB or RS-232 interface board installed as an option. Refer to the separate interface manual for all setup and operation instructions for remote digital programming.

Remote Operation

Remote Analog Programming of Output Voltage and Current Limit

Remote Analog Programming Procedure



CAUTION

To maintain the isolation of the power supply output and prevent ground loops, use an isolated (ungrounded) programming source when operating the power supply via remote analog control at the J2 connector.



CAUTION

The remote programming inputs are internally referenced to the supply's negative output. Do not connect control ground (rear panel J2 connector terminal J2-3 or J2-6) to the supply's positive output.

1. Turn the power supply OFF.
2. Using [Table 4.1](#), set switches SW1-1, SW1-2, SW1-3, and SW1-4 according to the selected programming sources. See Notes at the end of this procedure for more information about switch settings.
3. Install any J2 connector jumpers as indicated in [Table 4.1](#).
4. Connect the programming source(s) to the rear panel J2 connector as shown in [Figure 4.1](#), observing the correct polarity for voltage sources.
5. Set the programming sources to the desired levels and turn the power supply ON. The REM LED turns on.
6. Adjust the external programming source to change the power supply's output.

Notes:

- Switches SW-1 to SW-4 can be set to their defaults (all open) unless otherwise specified in [Table 4.1](#). See SW1 Programming Switch for default settings. Switches SW1-5, SW1-6, SW1-7, and SW1-8 are not required for remote programming. They can remain at the settings you have selected for your application.
- Resetting switches SW1-3 or SW1-4, the programming scale selection switches, may require that you recalibrate the programming circuit to maintain programming accuracy. See [Calibrating for Programming Accuracy](#).
- The control circuits have been designed to allow you to set output voltage and current up to 5% over the model-rated maximum values. The power supply will operate within these extended ranges, but we cannot guarantee full performance to specification.

Remote Operation

Remote Analog Programming of Output Voltage and Current Limit

Table 4.1 Power Supply Settings for Different Programming Sources

Output Voltage Programming Source	Output Current Limit Programming Source				
	0-5 Vdc	0-10 Vdc	0-5 k Resistor	0-10 k Resistor	None (Front Panel Control)
0-5 Vdc	SW1: use default settings. J2: jumper 3 to 4, 3 to 5.	SW1: set 4 closed. J2: jumper 3 to 4, 3 to 5.	SW1: set 2 closed. J2 Jumper 3 to 4, 3 to 5.	SW1: set 2 and 4 closed. J2: jumper 3 to 4, 3 to 5.	SW1: use default settings. J2: jumper 3 to 4.
0-10 Vdc	SW1: set 3 closed: J2: jumper 3 to 4, 3 to 5.	SW1: set 3 and 4 closed. J2: jumper 3 to 4, 3 to 5.	SW1: set 2 and 3 closed. J2: jumper 3 to 4, 3 to 5.	SW1: set 2, 3, and 4 closed. J2: jumper 3 to 4, 3 to 5.	SW1: set 3 closed. J2: jumper 3 to 4.
0-5 k Resistor	SW1: set 1 closed. J2: jumper 3 to 4, 3 to 5.	SW1: set 1 and 4 closed. J2: jumper 3 to 4, 3 to 5.	SW1: set 1 and 2 closed. J2: jumper 3 to 4, 3 to 5.	SW1: set 1, 2, and 4 closed. J2: jumper 3 to 4, 3 to 5.	SW1: set 1 closed. J2: jumper 3 to 4.
0-10 k Resistor	SW1: set 1 and 3 closed. J2: jumper 3 to 4, 3 to 5.	SW1: set 1, 3, and 4 closed. J2: jumper 3 to 4, 3 to 5.	SW1: set 1, 2, and 3 closed. J2: jumper 3 to 4, 3 to 5.	SW1: set 1, 2, 3, and 4 closed. J2: jumper 3 to 4, 3 to 5.	SW1: set 1 and 3 closed. J2: jumper 3 to 4.
None (Front Panel Control)	SW1: use default settings. J2: jumper 3 to 5.	SW1: set 4 closed. J2: jumper 3 to 5.	SW1: set 2 closed. J2: jumper 3 to 5.	SW1: set 2 and 4 closed. J2: jumper 3 to 5.	SW1: use default settings. J2: no jumpers

Remote Operation

Remote Analog Programming of Output Voltage and Current Limit

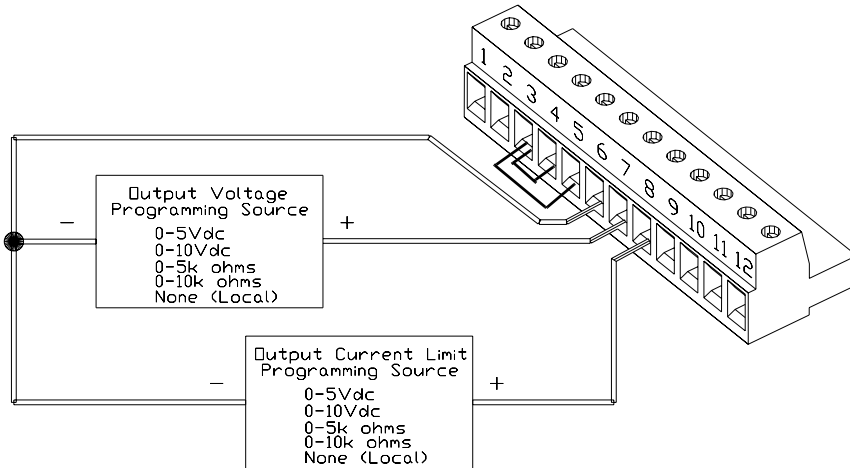

Figure 4.1 Connecting Programming Sources to J2 Connector

Sample Configuration

The sample configuration in [Figure 4.2](#) shows the required settings and connections for:

- 0-10 Vdc programming of the output voltage
- local control (front panel control) of the output current limit

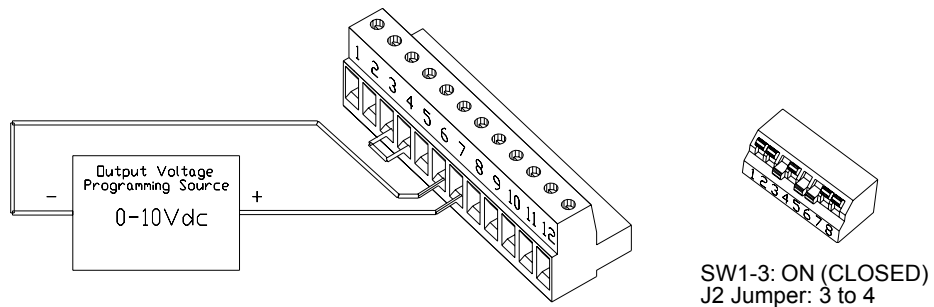

Figure 4.2 Sample Analog Programming Configuration

Remote Monitoring of Output Voltage and Current

Readback Signals The J2 connector on the rear panel provides access to calibrated readback signals for remote monitoring of the output voltage and current. Use rear panel switches SW1-5 and SW1-6 to select either a 0-5 Vdc or a 0-10 Vdc range for the output. The readback signal represents 0 to 100% of the power supply's output.

See [Table 4.2](#) for the required J2 connections and switch settings for remote monitoring of readback signals with 0-5 Vdc or 0-10 Vdc outputs. Use shielded pair wiring (20 to 24 AWG) and ground the shield to J2 connector terminal 1 or to the chassis. See [Figure 4.3](#) and [Figure 4.4](#) for sample configurations using remote monitoring.

Table 4.2 Power Supply Settings for Remote Monitoring of Readback Signals

Readback Signal	J2 Connection Signal (+)	J2 Connection Return (-)	Switch SW1 Setting
Output Voltage (0-5 Vdc)	J2-9	J2-6	SW1-5 ON (CLOSED)
Output Voltage (0-10 Vdc)	J2-9	J2-6	SW1-5 OFF (OPEN)
Output Current (0-5 Vdc)	J2-10	J2-6	SW1-6 ON (CLOSED)
Output Current (0-10 Vdc)	J2-10	J2-6	SW1-6 OFF (OPEN)

Note: Check the readback accuracy any time you reset the SW1 switch. Access offset and range adjustment for the readback signals through the cover of the unit. See “Calibrating for Readback Accuracy” on page 80.

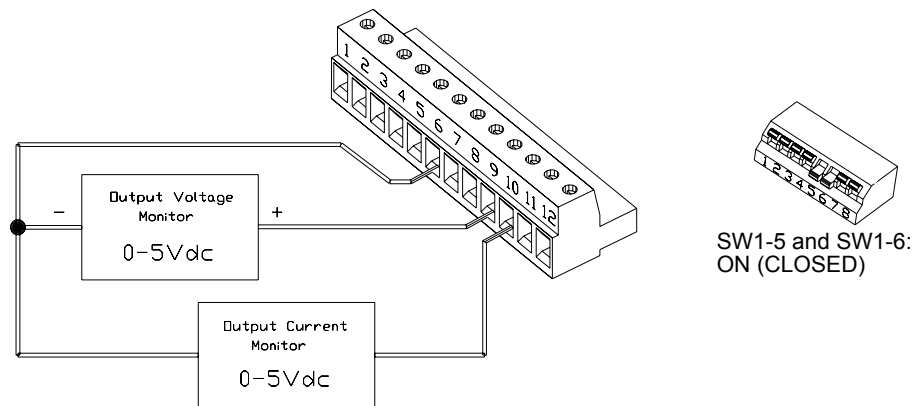

Figure 4.3 0-5 Vdc Output Voltage and Current Monitoring

Remote Operation

Using the Isolated Programming (ISOL) Interface Option

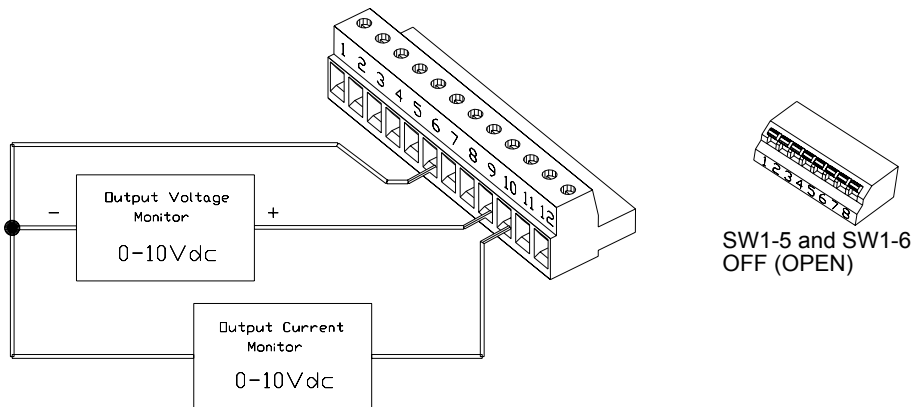

Figure 4.4 0-10 Vdc Output Voltage and Current Monitoring

Using the Isolated Programming (ISOL) Interface Option

With the 4-channel Isolated (ISOL) Programming Interface installed, you can control and monitor the power supply's output voltage and current limit using 0-5 V analog signals that are not referenced to the power supply's internal ground. The isolation amplifiers used are rated to 1000 Vdc. With ISOL installed, the power supply will no longer support resistive programming, or 0-10 V programming or readback. You can still control any non-programmed function (either voltage or current limit) at the power supply's front panel.

ISOL Specifications	Nominal Gain	1 V/V typical
	Gain vs. Temperature	± 10 ppm/ $^{\circ}$ C typical
	Non Linearity	$\pm 0.016\%$ FSR typical, $\pm 0.020\%$ FSR maximum
	Offset Voltage	± 20 mV typical, ± 50 mV maximum
	Input vs. Temperature	± 200 mV/ $^{\circ}$ C typical
	Input Voltage Range	0-5 V
	Input Impedance	200 k typical
	Readback Voltage Range	0-5 V
	Readback Current Drive	± 15 mA typical, ± 5 mA minimum
	Readback Load Capacitance	0.1 mF typical

**ISOL Setup
and
Operating
Instructions**



CAUTION

In order to maintain isolation, do not connect either J2 connector terminal 3 (control ground) or the power supply return to J2 terminal 6 (program/monitor signal return).

1. Ensure that the rear panel SW1 switch is set to its default configuration as in Figure 1.4 , on p. 19.
2. Connect the 0-5 V programming source to the J2 connector on the power supply's rear panel as described in [Section 4. Remote Operation](#).
3. Once the connections are made, use the power supply with the ISOL interface installed as you would a power supply with a 0-5 Vdc programming source. The only differences are that the programming and monitoring sources are now isolated and that resistive and 0-10 V programming as well as 0-10 V monitoring are unavailable. All front panel functions are as usual.

ISOL Calibration To calibrate a unit which has the ISOL interface installed, have the service technician follow the standard procedures in Section 5. Calibration.

Remote Operation

Using the Isolated Programming (ISOL) Interface Option

Section 5. Calibration

Calibration Setup



WARNING- HIGH ENERGY AND HIGH VOLTAGE

Exercise caution when using and servicing a power supply. High energy levels can be stored at the output voltage terminals on a power supply in normal operation. In addition, potentially lethal voltages exist in the primary circuit and on the output and sense connectors of a power supply with a rated output greater than 40 V. Filter capacitors store potentially dangerous energy for some time after power is removed.

**Service
Environment
and
Precautions**

- Follow established antistatic procedures.
- Work at a bench with adequate room and support for the test unit and for all equipment required.
- To reduce shock hazard, use only an insulated, straight-bladed screwdriver when calibrating trim potentiometers.
- NEVER test these units alone. Ensure that someone is present who can help should an accident occur.

**Equipment
Required**

You will need the following equipment when calibrating your supply.

- 5-1/2 digit true RMS voltmeters (DVMs) ($\pm 0.05\%$ accuracy) with test leads.
- Current shunt 1 mV/amp ($\pm 0.25\%$) and connecting wire. Current rating for the DC shunt and connecting wire must be at least 10% greater than the power supply's output current rating. See also Table 2.3, "Current Carrying Capacity for Wiring".
- Non-conducting, straight-bladed screwdriver.

Calibration

Front Panel Calibration

Front Panel Calibration

Front panel calibration includes voltmeter, ammeter, voltage and current preview and over voltage protection (OVP) setpoint and preview functions. Perform all procedures in the sequence give.

Additional Setup Make calibration adjustments using multiturn potentiometers accessed by removing the power supply's cover.

1. Unfasten the cover and move it back one inch from the front to allow access to the calibration potentiometers on the A1 PCB. Refer to [Figure 5.1](#) for the location of the pots.
2. Perform the following calibration procedures.
3. Once you are finished, turn off the power supply and replace the cover

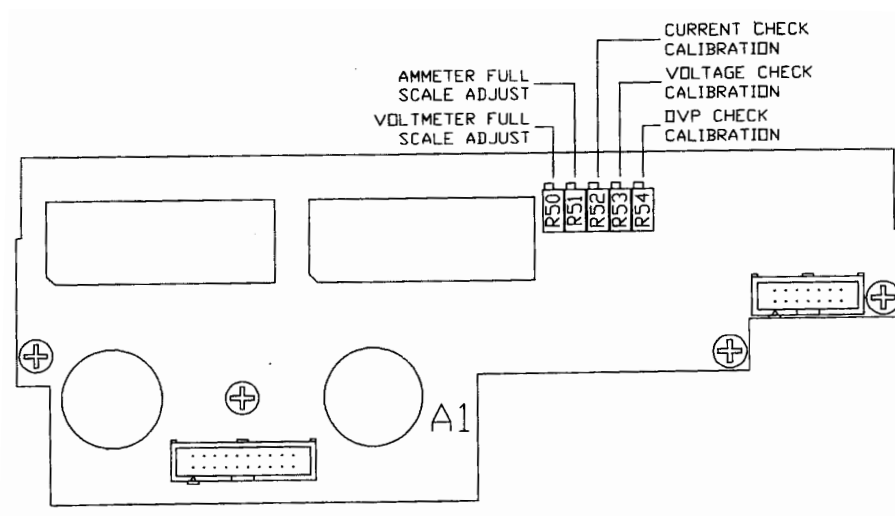

Figure 5.1 Front Panel Calibration Locations

Voltmeter Calibration

1. Connect the DVM to the output bus bars at a point close to the chassis. Turn the current control knob fully clockwise.
2. Increase the output voltage to show the maximum rated voltage on the external DVM. Adjust the voltmeter full scale adjust potentiometer (R50) until the front panel voltmeter reads the maximum rated output voltage. Check that the front panel voltage mode LED turns on.

3. Press the front panel STANDBY switch to its IN position. Check that the output voltage drops to 0V in less than 2 seconds. Check that the S/D LED turns on.
4. While holding the front panel V/I CHECK switch in, adjust the voltage check calibration potentiometer (R53) until the front panel meter reads the maximum rated output.
5. Press the STANDBY switch again to its OUT position to resume normal power supply operation and to reset the output.

Ammeter Calibration

1. Connect the DVM across the output current shunt with the negative lead connected to the power supply return side of the shunt. Turn the voltage control knob fully clockwise.
2. Turn on the load and adjust the load until the external DVM reads the maximum rated output voltage.
3. Adjust the ammeter full scale adjust potentiometer (R51) until the front panel ammeter reads the maximum rated output current.
4. While holding the front panel V/I CHECK switch in, adjust the current check calibration potentiometer (R52) until the front panel ammeter reads the maximum rated output current.
5. Turn off the load.

Over Voltage Protection (OVP) Calibration

1. Set the output voltage to the maximum rated output voltage.
2. Slowly turn the front panel OVP SET screw counter clockwise until the OVP just fires. Check that the output voltage drops to 0V in less than 2 seconds. Check that the front panel OVP LED is on.
3. Lower the output voltage setting and press the front panel STANDBY switch twice to reset the output.
4. Increase the output voltage slowly until the OVP circuit just fires. Observe the voltage reading at firing point for future reference.
5. Press OVP CHECK, and adjust the OVP check calibration potentiometer (R54) to match the output voltage setting observed when the OVP circuit fired.
6. Repeat the process to ensure that the OVP preview reading is within 1% of the OVP fire point.
7. Turn the OVP SET screw fully clockwise.

Calibration

Calibrating for Programming Accuracy

Calibrating for Programming Accuracy



WARNING

Use a non-conducting, straight-bladed screwdriver to adjust the trim pots.

The factory calibrates the offset and range of the voltage and current programming circuits to within 1% for the default 0-5 Vdc programming signals. You may need to recalibrate when you change SW1 switch settings to use 0-10 Vdc programming or when you switch back to 0-5 Vdc programming after previously calibrating for 0-10 Vdc programming.

Make calibration adjustments using multi-turn potentiometers, accessed through holes in the cover of the power supply. See [Figure 5.2](#) for the location of each of the pots.

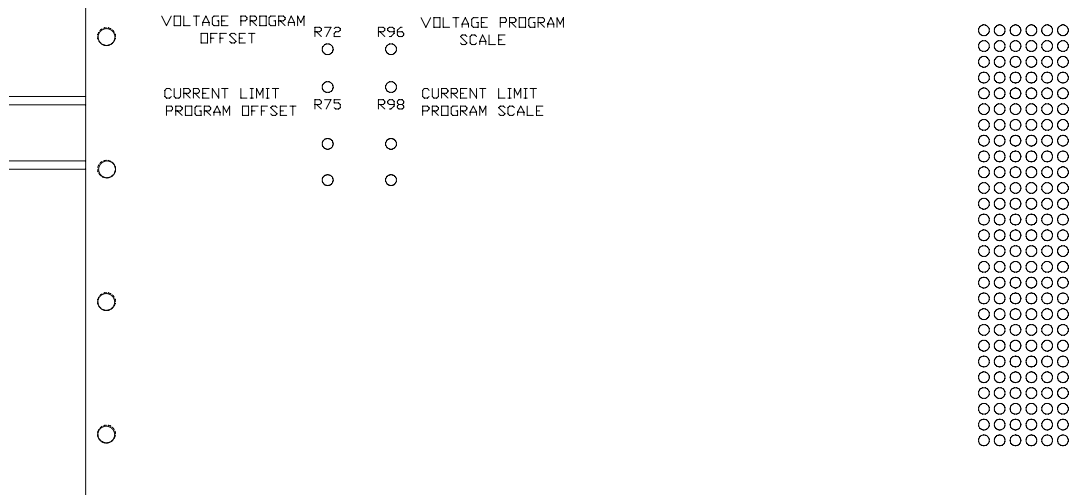

Figure 5.2 Voltage and Current Programming Calibration Locations

**Voltage
Programming
Circuit
Calibration**

1. Ensure that the power supply is turned OFF. Disconnect any load.
2. Connect the programming source between J2 terminals 7 (output voltage programming input) and 6 (program/monitor signal return).
3. Connect the DVM to the power supply output.
4. Turn the power supply ON.
5. Apply 1% of program voltage.
6. Adjust the voltage program offset potentiometer (R72) until the DVM reads 1% of the model-rated output voltage.
7. Apply 100% of program voltage.
8. Adjust the voltage program scale potentiometer (R96) until the DVM reads 100% of the model-rated output voltage.

Repeat this adjustment until output levels are within the product specifications as found in Section 1, or to the accuracy that your application requires.

**Current
Programming
Circuit
Calibration**

1. Ensure that the power supply is turned OFF. Disconnect any load.
2. Connect the program source between J2 connector terminals 8 (output current limit programming input) and 6 (program/monitor signal return).
3. Connect the shunt and DVM across the power supply output. See note below.
4. Turn the power supply ON.
5. Apply 1% of program voltage.
6. Adjust the current program offset potentiometer (R75) until the DVM indicates 1% of the model-rated output current. See note below.
7. Apply 100% of program voltage.
8. Adjust the current program scale potentiometer (R98) until the DVM indicates 100% of the model-rated output current. See note below.

Repeat this adjustment until output levels are adjusted to power supply specifications as found in Section 1, or to the accuracy your application requires.

Notes:

- The DC shunt-DVM combination must be rated better than 0.5% accuracy.
- Calculate the required DVM reading using $I = V/R$, where I is the current, V is the DVM reading, and R is the DC shunt resistance.

Calibration

Calibrating for Readback Accuracy

Calibrating for Readback Accuracy



WARNING

Use a non-conducting, straight-bladed screwdriver to adjust the trim pots.

The factory calibrates the offset and range of the output voltage and current monitor circuits to within 1% for the default 0-5 Vdc scales. Recalibration may be necessary when you change SW1 switch settings to select the 0-10 Vdc scale or when you switch back to the 0-5 Vdc scale after previously calibrating for 0-10 Vdc operation.

Make calibration adjustments using multi-turn potentiometers, accessible through holes in the cover of the power supply. Refer to [Figure 5.3](#) for the location of each of the pots.

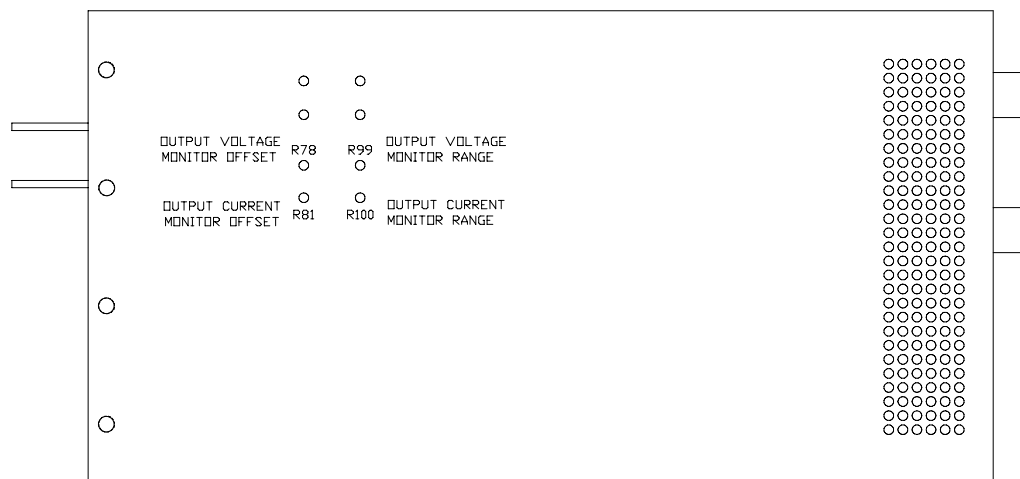

Figure 5.3 Voltage Current and Monitor Calibration Locations

**Output
Voltage
Monitor
Circuit
Calibration**

1. Ensure that the power supply is turned OFF. Disconnect any load.
2. Connect a DVM across the power supply output to read the output voltage.
3. Connect a second DVM to the rear panel J2 terminals 9 (output voltage monitor) and 6 (program/monitor signal return). See notes below.
4. Turn the power supply ON.
5. Set the power supply output voltage to 1% of the model-rated output.
6. Adjust the output voltage monitor offset potentiometer (R78) until the monitor DVM reads 1% of the readback scale. (50 mVdc for 0-5 Vdc readback or 100 mVdc for 0-10 Vdc readback.)
7. Set the power supply output voltage to the model-rated maximum output.
8. Adjust the output voltage monitor range potentiometer (R99) until the monitor DVM reads 100% of the readback scale. (5 Vdc for 0-5 Vdc readback or 10 Vdc for 0-10 Vdc readback.)

Repeat this adjustment until the monitor signal is within the product specifications as found in Section 1, or to the accuracy that your application requires.

Notes:

- The recommended accuracy rating for the DVMs is four times better than your desired readback accuracy.
- Depending on the readback accuracy required in your application, you may use the front panel voltmeter in place of the meter used to monitor the output of the supply.

Calibration

Calibrating for Readback Accuracy

Output Current Monitor Circuit Calibration

1. Ensure that the power supply is turned OFF. Disconnect any load.
2. Connect the shunt and DVM across the power supply output to read the output current.
3. Connect a second DVM to the rear panel J2 terminals 10 (output current monitor) and 6 (program/monitor signal return). See notes below.
4. Turn the current control fully counter-clockwise, then turn ON the power supply.
5. Set the supply output current to 1% of its model-rated output. See note below.
6. Adjust the output current monitor offset potentiometer (R81) until the monitor DVM indicates 1% of the readback scale. (50 mVdc for 0-5 V readback or 100 mVdc for 0-10 Vdc readback.)
7. Set the supply output current to the model-rated maximum output.
8. Adjust the output current monitor range potentiometer (R100) until the monitor DVM reads 100% of the readback scale. (5 Vdc for 0-5 V readback or 10 Vdc for 0-10 Vdc readback.)

Repeat this adjustment until the monitor scale is within the product specifications as found in Section 1, or to the accuracy that your application requires.

Notes:

- The recommended accuracy of the DVM and DC shunt-DVM combination is four times better than your desired readback accuracy. The recommended current ratings for the DC shunt and connecting wire is at least 10% greater than the power supply's output current rating.
- Depending on the readback accuracy required in your application, you may use the front panel ammeter in place of the DC shunt-DVM combination.
- Calculate the required output current reading using $I = V/R$ where I is the current, V is the DVM reading, and R is the DC shunt resistance.