

**KEITHLEY**

# Model 2304A High Speed Power Supply

User's Manual

A GREATER MEASURE OF CONFIDENCE

# WARRANTY

Keithley Instruments, Inc. warrants this product to be free from defects in material and workmanship for a period of 1 year from date of shipment.

Keithley Instruments, Inc. warrants the following items for 90 days from the date of shipment: probes, cables, rechargeable batteries, diskettes, and documentation.

During the warranty period, we will, at our option, either repair or replace any product that proves to be defective.

To exercise this warranty, write or call your local Keithley representative, or contact Keithley headquarters in Cleveland, Ohio. You will be given prompt assistance and return instructions. Send the product, transportation prepaid, to the indicated service facility. Repairs will be made and the product returned, transportation prepaid. Repaired or replaced products are warranted for the balance of the original warranty period, or at least 90 days.

## LIMITATION OF WARRANTY

This warranty does not apply to defects resulting from product modification without Keithley's express written consent, or misuse of any product or part. This warranty also does not apply to fuses, software, non-rechargeable batteries, damage from battery leakage, or problems arising from normal wear or failure to follow instructions.

THIS WARRANTY IS IN LIEU OF ALL OTHER WARRANTIES, EXPRESSED OR IMPLIED, INCLUDING ANY IMPLIED WARRANTY OF MERCHANTABILITY OR FITNESS FOR A PARTICULAR USE. THE REMEDIES PROVIDED HEREIN ARE BUYER'S SOLE AND EXCLUSIVE REMEDIES.

NEITHER KEITHLEY INSTRUMENTS, INC. NOR ANY OF ITS EMPLOYEES SHALL BE LIABLE FOR ANY DIRECT, INDIRECT, SPECIAL, INCIDENTAL OR CONSEQUENTIAL DAMAGES ARISING OUT OF THE USE OF ITS INSTRUMENTS AND SOFTWARE EVEN IF KEITHLEY INSTRUMENTS, INC., HAS BEEN ADVISED IN ADVANCE OF THE POSSIBILITY OF SUCH DAMAGES. SUCH EXCLUDED DAMAGES SHALL INCLUDE, BUT ARE NOT LIMITED TO: COSTS OF REMOVAL AND INSTALLATION, LOSSES SUSTAINED AS THE RESULT OF INJURY TO ANY PERSON, OR DAMAGE TO PROPERTY.



Keithley Instruments, Inc. • 28775 Aurora Road • Cleveland, OH 44139 • 440-248-0400 • Fax: 440-248-6168 • <http://www.keithley.com>

CHINA:	Keithley Instruments China • Yuan Chen Xin Building, Room 705 • 12 Yumin Road, Dewai, Madian • Beijing 100029 • 8610-62022886 • Fax: 8610-62022892
FRANCE:	Keithley Instruments SARL • BP 60 • 3 Allée des Garays • 91122 Palaiseau Cédex • 33-1-60-11-51-55 • Fax: 33-1-60-11-77-26
GERMANY:	Keithley Instruments GmbH • Landsberger Strasse 65 • D-82110 Germering, Munich • 49-89-8493070 • Fax: 49-89-84930759
GREAT BRITAIN:	Keithley Instruments, Ltd. • The Minster • 58 Portman Road • Reading, Berkshire RG30 1EA • 44-118-9575666 • Fax: 44-118-9596469
ITALY:	Keithley Instruments SRL • Viale S. Gimignano 38 • 20146 Milano • 39-2-48303008 • Fax: 39-2-48302274
NETHERLANDS:	Keithley Instruments BV • Avelingen West 49 • 4202 MS Gorinchem • 31-(0)183-635333 • Fax: 31-(0)183-630821
SWITZERLAND:	Keithley Instruments SA • Kriesbachstrasse 4 • 8600 Dübendorf • 41-1-8219444 • Fax: 41-1-8203081
TAIWAN:	Keithley Instruments Taiwan • 1FL., 85 Po Ai Street • Hsinchu, Taiwan • 886-3-572-9077 • Fax: 886-3-572-9031

---

# Model 2304A High Speed Power Supply User's Manual

©1998, Keithley Instruments, Inc.  
All rights reserved.  
Cleveland, Ohio, U.S.A.  
Second Printing, March 1999  
Document Number: 2304A-900-01 Rev. B

---

# Manual Print History

The print history shown below lists the printing dates of all Revisions and Addenda created for this manual. The Revision Level letter increases alphabetically as the manual undergoes subsequent updates. Addenda, which are released between Revisions, contain important change information that the user should incorporate immediately into the manual. Addenda are numbered sequentially. When a new Revision is created, all Addenda associated with the previous Revision of the manual are incorporated into the new Revision of the manual. Each new Revision includes a revised copy of this print history page.

Revision A (Document Number 2304A-900-01) .....	January 1998
Revision B (Document Number 2304A-900-01) .....	March 1999

---

## Safety Precautions

The following safety precautions should be observed before using this product and any associated instrumentation. Although some instruments and accessories would normally be used with non-hazardous voltages, there are situations where hazardous conditions may be present.

This product is intended for use by qualified personnel who recognize shock hazards and are familiar with the safety precautions required to avoid possible injury. Read the operating information carefully before using the product.

The types of product users are:

**Responsible body** is the individual or group responsible for the use and maintenance of equipment, for ensuring that the equipment is operated within its specifications and operating limits, and for ensuring that operators are adequately trained.

**Operators** use the product for its intended function. They must be trained in electrical safety procedures and proper use of the instrument. They must be protected from electric shock and contact with hazardous live circuits.

**Maintenance personnel** perform routine procedures on the product to keep it operating, for example, setting the line voltage or replacing consumable materials. Maintenance procedures are described in the manual. The procedures explicitly state if the operator may perform them. Otherwise, they should be performed only by service personnel.

**Service personnel** are trained to work on live circuits, and perform safe installations and repairs of products. Only properly trained service personnel may perform installation and service procedures.

Exercise extreme caution when a shock hazard is present. Lethal voltage may be present on cable connector jacks or test fixtures. The American National Standards Institute (ANSI) states that a shock hazard exists when voltage levels greater than 30V RMS, 42.4V peak, or 60VDC are present. **A good safety practice is to expect that hazardous voltage is present in any unknown circuit before measuring.**

Users of this product must be protected from electric shock at all times. The responsible body must ensure that users are prevented access and/or insulated from every connection point. In some cases, connections must be exposed to potential human contact. Product users in these circumstances must be trained to protect themselves from the risk of electric shock. If the circuit is capable of operating at or above 1000 volts, **no conductive part of the circuit may be exposed.**

As described in the International Electrotechnical Commission (IEC) Standard IEC 664, digital multimeter measuring circuits (e.g., Keithley Models 175A, 199, 2000, 2001, 2002, and 2010) are Installation Category II. All other instruments' signal terminals are Installation Category I and must not be connected to mains.

Do not connect switching cards directly to unlimited power circuits. They are intended to be used with impedance limited sources. NEVER connect switching cards directly to AC mains. When connecting sources to switching cards, install protective devices to limit fault current and voltage to the card.

Before operating an instrument, make sure the line cord is connected to a properly grounded power receptacle. Inspect the connecting cables, test leads, and jumpers for possible wear, cracks, or breaks before each use.

For maximum safety, do not touch the product, test cables, or any other instruments while power is applied to the circuit under test. ALWAYS remove power from the entire test system and discharge any capacitors before: connecting or disconnecting cables or jumpers, installing or removing switching cards, or making internal changes, such as installing or removing jumpers.

Do not touch any object that could provide a current path to the common side of the circuit under test or power line (earth) ground. Always make measurements with dry hands while standing on a dry, insulated surface capable of withstanding the voltage being measured.

---

The instrument and accessories must be used in accordance with its specifications and operating instructions or the safety of the equipment may be impaired.

Do not exceed the maximum signal levels of the instruments and accessories, as defined in the specifications and operating information, and as shown on the instrument or test fixture panels, or switching card.

When fuses are used in a product, replace with same type and rating for continued protection against fire hazard.

Chassis connections must only be used as shield connections for measuring circuits, NOT as safety earth ground connections.

If you are using a test fixture, keep the lid closed while power is applied to the device under test. Safe operation requires the use of a lid interlock.

If a  screw is present, connect it to safety earth ground using the wire recommended in the user documentation.

The  symbol on an instrument indicates that the user should refer to the operating instructions located in the manual.

The  symbol on an instrument shows that it can source or measure 1000 volts or more, including the combined effect of normal and common mode voltages. Use standard safety precautions to avoid personal contact with these voltages.

The **WARNING** heading in a manual explains dangers that might result in personal injury or death. Always read the associated information very carefully before performing the indicated procedure.

The **CAUTION** heading in a manual explains hazards that could damage the instrument. Such damage may invalidate the warranty.

Instrumentation and accessories shall not be connected to humans.

Before performing any maintenance, disconnect the line cord and all test cables.

To maintain protection from electric shock and fire, replacement components in mains circuits, including the power transformer, test leads, and input jacks, must be purchased from Keithley Instruments. Standard fuses, with applicable national safety approvals, may be used if the rating and type are the same. Other components that are not safety related may be purchased from other suppliers as long as they are equivalent to the original component. (Note that selected parts should be purchased only through Keithley Instruments to maintain accuracy and functionality of the product.) If you are unsure about the applicability of a replacement component, call a Keithley Instruments office for information.

To clean an instrument, use a damp cloth or mild, water based cleaner. Clean the exterior of the instrument only. Do not apply cleaner directly to the instrument or allow liquids to enter or spill on the instrument. Products that consist of a circuit board with no case or chassis (e.g., data acquisition board for installation into a computer) should never require cleaning if handled according to instructions. If the board becomes contaminated and operation is affected, the board should be returned to the factory for proper cleaning/servicing.

---

# Table of Contents

<b>1</b>	<b>General Information</b>	
	Introduction .....	1-2
	Warranty information .....	1-2
	Manual addenda .....	1-2
	Safety symbols and terms .....	1-2
	Specifications .....	1-3
	Inspection .....	1-3
<b>2</b>	<b>Front Panel Operation</b>	
	Power supply overview .....	2-2
	Power-up .....	2-4
	Line power connection .....	2-4
	Fuse replacement .....	2-5
	Power-up sequence .....	2-5
	Default settings .....	2-6
	Display types .....	2-7
	Remote display option .....	2-8
	Test connections .....	2-8
	Setting voltage and current values .....	2-9
	Procedure to edit voltage and current values .....	2-9
	OPERATE .....	2-10
	Output readback .....	2-11
	Current limit .....	2-11
	Enhanced output response .....	2-12
	Independent voltage measurements (DVM) .....	2-12
	Pulse-current measurements .....	2-12
	Pulse current digitization .....	2-14
	Programming examples .....	2-15
	Pulse-current measurement procedure .....	2-16
	Determining correct trigger level .....	2-16
	Long integration current measurements .....	2-17
	Long integration measurement procedure .....	2-19
	Determining correct trigger level .....	2-19
	Sink operation .....	2-20
	Relay control .....	2-21
	Connections .....	2-22
	Controlling the relays .....	2-23
	MENU .....	2-24
	Rules to navigate MENU .....	2-25
	MENU structure .....	2-25

---

# 3

## GPIB Operation

Introduction .....	3-2
GPIB bus connections .....	3-2
Primary address .....	3-3
QuickBASIC 4.5 programming .....	3-3
Universal language driver installation .....	3-3
Using program fragments .....	3-3
General bus commands .....	3-4
REN (remote enable) .....	3-5
IFC (interface clear) .....	3-5
LLO (local lockout) .....	3-5
GTL (go to local) .....	3-6
DCL (device clear) .....	3-6
SDC (selective device clear) .....	3-6
GET (group execute trigger) .....	3-6
SPE, SPD (serial polling) .....	3-7
Front panel aspects of GPIB operation .....	3-7
Remote indicator and LOCAL key .....	3-7
Error and status messages .....	3-7
Status structure .....	3-11
Condition registers .....	3-12
Event registers .....	3-12
Enable registers .....	3-12
Queues .....	3-13
Status Byte and Service Request (SRQ) .....	3-16
Programming syntax .....	3-19
Command words .....	3-19
Program messages .....	3-22
Response messages .....	3-24
Message exchange protocol .....	3-24
Common commands .....	3-25



---

## 4

### SCPI Command Reference

Introduction .....	4-2
Signal oriented measurement commands .....	4-2
SCPI command subsystems reference tables .....	4-4
:DISPlay subsystem .....	4-9
FORMat subsystem .....	4-11
OUTPut subsystem .....	4-15
SENSe subsystem .....	4-16
Voltage, current, and DVM commands .....	4-17
Current range commands .....	4-18
Pulse-current commands .....	4-19
:TIME commands .....	4-20
:SYNChronize commands .....	4-21
Long integration commands .....	4-22
SOURce subsystem .....	4-25
Set voltage value .....	4-25
Configure current limit .....	4-25
STATus subsystem .....	4-27
Read event registers .....	4-27
Program event enable registers .....	4-29
Read condition registers .....	4-31
Select default conditions .....	4-31
Error queue .....	4-32
:SYSTem subsystem .....	4-33

## A

### Specifications

---

# List of Illustrations

## 2 Front Panel Operation

Figure 2-1	Model 2304A high speed power supply .....	2-2
Figure 2-2	Simplified power supply diagram .....	2-3
Figure 2-3	Typical connections .....	2-8
Figure 2-4	Pulse-current measurement .....	2-13
Figure 2-5	Sink operation .....	2-20
Figure 2-6	Relay control .....	2-21
Figure 2-7	Miniature phono plug .....	2-22

## 3 GPIB Operation

Figure 3-1	IEEE-488 connector .....	3-2
Figure 3-2	Model 2304A status register structure .....	3-11
Figure 3-3	Standard event status .....	3-14
Figure 3-4	Operation event status .....	3-14
Figure 3-5	Measurement event status .....	3-15
Figure 3-6	Questionable event status .....	3-15
Figure 3-7	Status byte and service request (SRQ) .....	3-16
Figure 3-8	Standard event enable register .....	3-27
Figure 3-9	Standard event status register .....	3-28
Figure 3-10	Service request enable register .....	3-32
Figure 3-11	Status byte register .....	3-33

## 4 SCPI Command Reference

Figure 4-1	IEEE754 single precision data format .....	4-12
Figure 4-2	IEEE754 double precision data format .....	4-13
Figure 4-3	Measurement event register .....	4-27
Figure 4-4	Questionable event register .....	4-27
Figure 4-5	Operation event register .....	4-28
Figure 4-6	Measurement event enable register .....	4-30
Figure 4-7	Questionable event enable register .....	4-30
Figure 4-8	Operation event enable register .....	4-30

---

# List of Tables

## 2 Front Panel Operation

Table 2-1	Factory defaults (RST) .....	2-6
Table 2-2	Switchcraft connection accessories .....	2-23
Table 2-3	MENU structure .....	2-24

## 3 GPIB Operation

Table 3-1	General bus commands and associated statements .....	3-4
Table 3-2	Status and error messages .....	3-8
Table 3-3	Common commands .....	3-25

## 4 SCPI Command Reference

Table 4-1	Signal oriented measurement command summary .....	4-2
Table 4-2	DISPlay command summary .....	4-5
Table 4-3	FORMat command summary .....	4-5
Table 4-4	OUTPut command summary .....	4-5
Table 4-5	SENSE command summary .....	4-6
Table 4-6	SOURce command summary .....	4-7
Table 4-7	STATus command summary .....	4-8
Table 4-8	SYSTem command summary .....	4-9

# General Information

---

## Introduction

This section contains general information about the Model 2304A High Speed Power Supply. If you have any questions after reviewing this information, please contact your local Keithley representative or call one of our Applications Engineers at 1-800-3735 (U.S. and Canada only). Worldwide phone numbers are listed at the front of this manual.

## Warranty information

Warranty information is located at the front of this manual. Should your Model 2304A require warranty service, contact the Keithley representative or authorized repair facility in your area for further information. When returning the instrument for repair, be sure to fill out and include the service form at the back of this manual to provide the repair facility with the necessary information.

## Manual addenda

Any improvements or changes concerning the instrument or manual will be explained in an addendum included with the manual. Be sure to note these changes and incorporate them into the manual.

## Safety symbols and terms

Keithley uses a standard set of safety symbols and terms that may be found on an instrument or in its manual.

The  symbol on an instrument indicates that the user should refer to the operating instructions located in the manual.

The  symbol on an instrument shows that high voltage may be present on the terminal(s). Use standard safety precautions to avoid personal contact with these voltages.

The **WARNING** heading used in a manual explains dangers that might result in personal injury or death. Always read the associated information very carefully before performing the indicated procedure.

The **CAUTION** heading used in a manual explains hazards that could damage the instrument. Such damage may invalidate the warranty.

# Specifications

Full Model 2304A specifications can be found in Appendix A of this manual.

# Inspection

The Model 2304A was carefully inspected electrically and mechanically before shipment. After unpacking all items from the shipping carton, check for any obvious signs of physical damage that may have occurred during transit. (Note: There may be a protective film over the display lens, which can be removed.) Report any damage to the shipping agent immediately. Save the original packing carton for possible future shipment. The following items are included with every Model 2304A order:

- Model 2304A High Speed Power Supply with line cord
- Quick Disconnect Output/DVM Input Connector
- Accessories as ordered
- Certificate of calibration
- Model 2304A User's Manual (P/N 2304A-900-00)
- Model 2304 Calibration Manual (P/N 2304-902-00)

If an additional manual is required, order the appropriate manual package. The manual package includes a manual and any pertinent addenda.

**2**

# Front Panel Operation

---

## Power supply overview

The Model 2304A High Speed Power Supply (shown in Figure 2-1) can output up to +20V (1mV resolution) at up to 5A. Voltage can be set in 1mV steps, and current limit can be set in 100 $\mu$ A steps. Maximum power output is 100W. The power supply can also be used to sink current (up to 3A). As a sink (current polarity is negative), the power supply is dissipating power rather than sourcing it. (See “Sink operation” for details.)

**Figure 2-1**  
Model 2304A high speed power supply

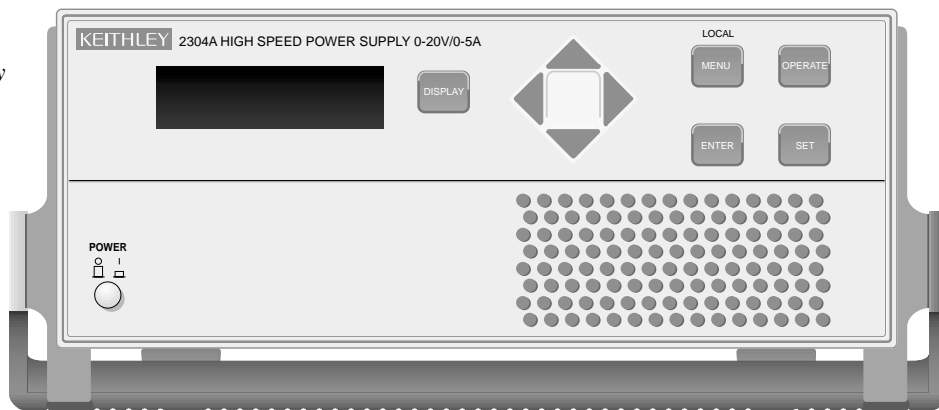

A) Front Panel

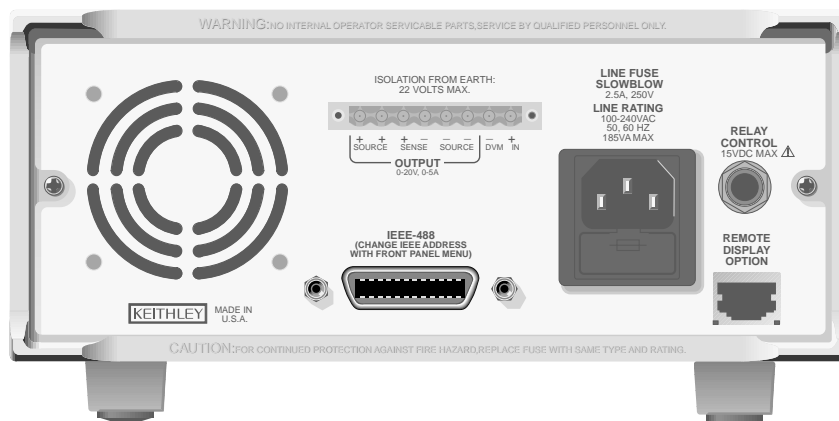

B) Rear Panel



A simplified diagram of the Model 2304A is shown in Figure 2-2. Note that it can read back the output voltage ( $V_{\text{meter}}$ ) and current ( $I_{\text{meter}}$ ). Display resolution for voltage readback is 1mV. There are two ranges for current readback: 5A and 5mA. On the 5A range, display resolution is 100 $\mu$ A, and on the 5mA range, resolution is 0.1 $\mu$ A.

The Model 2304A also has a digital voltmeter (DVM) that is independent of the power supply circuit. The DVM can measure up to +20V (1mV resolution).

When used with a pulsed load, the Model 2304A can read back peak current, idle current, and average current. See “Pulse-current measurements” for details. A long integration (up to 60 seconds) function is provided to measure average current of a low frequency pulse (long period) or a series of pulses. See “Long integration current measurements” for details.

**Figure 2-2**  
*Simplified power supply diagram*

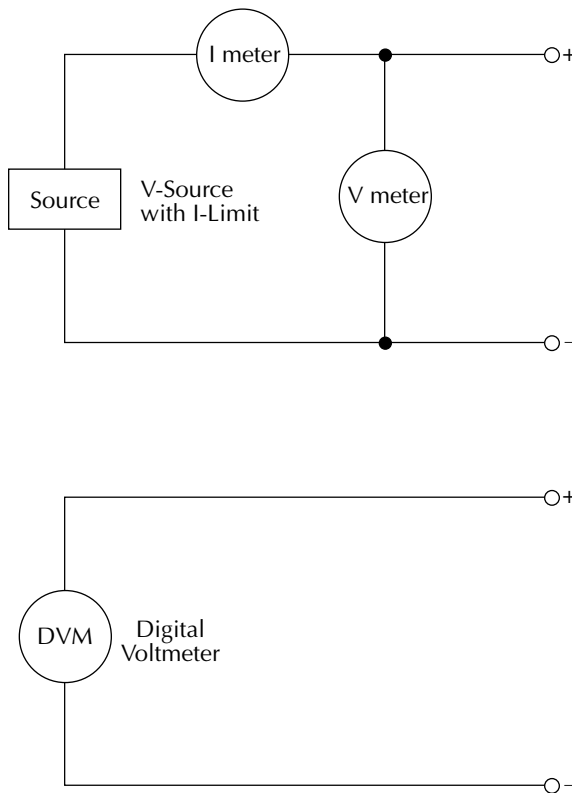

# Power-up

## Line power connection

The Model 2304A operates from a line voltage in the range of 100 to 240V at a frequency of 50 or 60Hz. Line voltage and frequency are automatically sensed, therefore there are no switches to set. Check to see that the line power in your area is compatible.

Perform the following steps to connect the power supply to the line power and turn it on:

1. Before plugging in the power cord, make sure the front panel power switch is in the off (0) position.
2. Connect the female end of the supplied power cord to the AC receptacle on the rear panel.

**WARNING** The power cord supplied with the Model 2304A contains a separate ground for use with grounded outlets. When proper connections are made, instrument chassis is connected to power line ground through the ground wire in the power cord. Failure to use a grounded outlet may result in personal injury or death due to electric shock.

3. Turn on the power supply by pressing the front panel power switch to the on (1) position.

## Fuse replacement

A rear panel fuse protects the power line input of the power supply. If the line fuse needs to be replaced, perform the following steps:

1. The fuse is located in a drawer below the AC receptacle (see Figure 2-1B). At the top of the fuse drawer is a small tab. At this location, use a thin-bladed knife or screwdriver to pry the fuse drawer open.
2. Slide the fuse drawer out to gain access to the fuse. Note that the fuse drawer does not pull all the way out of the power module.
3. Snap the fuse out of the drawer and replace it with the same type (250V, 2.5A, 5 × 20mm slo-blo). The Keithley part number is FU-106-2.5.

**CAUTION** For continued protection against fire or instrument damage, only replace the fuse with the type and rating listed. If the instrument repeatedly blows fuses, locate and correct the cause of the problem before replacing the fuse.

4. Push the fuse drawer back into the power module.

## Power-up sequence

On power-up, the Model 2304A performs self-tests on its EPROM and RAM.

**NOTE** *If a problem develops while the instrument is under warranty, return it to Keithley Instruments Inc., for repair.*

If the instrument passes the self-tests, the following information is briefly displayed:

- **Top line** — The model number (2304A) and the IEEE-488 address is displayed. At the factory, the address is set to 16.
- **Bottom line** — Firmware revision levels are displayed for the main board and the display board. Also displayed is the detected line frequency.

After the power-up sequence, the instrument goes to Actual V and I display type with the output off.

## Default settings

The power supply can be set to power-on to the factory default conditions (RST defaults) or to user-saved setup conditions. The factory default conditions are listed in Table 2-1.

The user can save up to five setups in memory (SAV0, SAV1, SAV2, SAV3, and SAV4). A setup can be saved in memory using the SAVE SETUP item of the MENU. The POWER ON SETUP item of the MENU is used to specify the power-on setup (RST or one of the user-saved setups).

The power supply can be returned to the RST or a user-saved default setup at any time by using the RECALL SETUP item of the MENU.

**Table 2-1**  
*Factory defaults (RST)*

Setting	RST default
Output value settings:	
Voltage (V)	0.000V
Current (A)	0.2500A
Operate	Off
Display type	Actual V and I
GPIB address	No effect (factory set to 16)
Current range	5 amps
Integration rate	1.00 PLC
Average readings	1
Power on setup	No effect (factory set to 16)
Current limit mode	Lim
Output relay 1	No effect (after power cycle, set to zero)
Output relay 2	No effect (after power cycle, set to zero)
Output response	Normal
Pulse current:	
High time	33μsec
Low time	33μsec
Average time	33μsec
Average readings	1
Trigger delay	0.00000 sec
Trigger level	0.000A
Long integration:	
Integration time	1 second
Pulse timeout	16 seconds
Trigger edge	Rising
Trigger level	0.000A

# Display types

For voltage and current readings, there are four display types. They are described as follows:

- **ACTUAL V AND I** — This display type is used to read back the actual output voltage and current. The power supply goes to this display type on power-up.
- **DVM INPUT** — This type is used to display the DC voltage applied to the DVM input of the power supply.
- **PULSE CURRENT** — This type is used to display high, low, or average pulse-current measurements.
- **LONG INTEGRATION** — This type is used to display average current measurements of a pulse or pulses using the long integration method.

A display type is selected as follows:

1. Press the DISPLAY key and use the ▲ or ▼ key to display the desired type; ACTUAL V AND I, DVM INPUT, PULSE CURRENT, or LONG INTEGRATION.
2. With the desired type displayed, press ENTER. Note that after selecting PULSE CURRENT, use the ▲ or ▼ key to select the desired pulse measurement: pulse high, pulse low, or pulse average. Examples of the display types are shown as follows:

Actual V and I:	6.116V	NL	ON
	1.2058A		
DVM input:	DVM INPUT	NL	ON
	4.993V		
Pulse current:	PULSE HI	NL	ON
	2.1947A		
	PULSE LO	NL	ON
	0.2147A		
	PULSE AVG	NL	ON
	1.1495A		
Long integration:	LONG INT	NL	ON
	1.0236A		

**NOTES** “NL” indicates that the normal output response is selected. With the enhanced output response selected, “EN” is displayed. See “Enhanced output response” for details.

“ON” indicates that the output is turned on. With the output turned off, “OFF” is displayed.

For the pulse current and Long Integration display types, “NO PULSE” is displayed if the output is off or pulses are not detected (output on). See “Pulse-current measurements” and “Long integration current measurements” for details.

When a change is made that effects the readings being taken, dashes are displayed instead of readings. The dashes remain until a valid reading for the new condition is taken.

## Remote display option

If the Model 2304A must be mounted in a location where the display is not readily visible or the controls are not easily accessible, the optional Model 2304-DISP Display Module can be used. This display module includes all instrument controls and has a nine foot cable so the power supply can be operated remotely from a more convenient location.

The remote display module plugs into the rear panel connector labeled “REMOTE DISPLAY OPTION” (Figure 2-1B). When plugged in, the main display module is disabled with the following message displayed:

REMOTE PANEL  
ENABLED

When the remote display module is unplugged, control returns to the main display module.

## Test connections

**WARNING** When installing a unit into a test system, make sure the external power sources do not apply voltage to the Model 2304A in excess of its maximum limits (see specifications). Failure to do so could result in personal injury or death.

Test connections to the power supply are made at the rear panel using a quick disconnect OUTPUT/DVM IN connector. (Figure 2-1B shows where the connector plugs in.) Use up to #14 AWG wire for the screw terminals of the connector. Once the connector is wired up, plug it into the rear panel and tighten the captive retaining screws.

Figure 2-3 shows typical power supply connections to the DUT.

**Figure 2-3**  
Typical connections

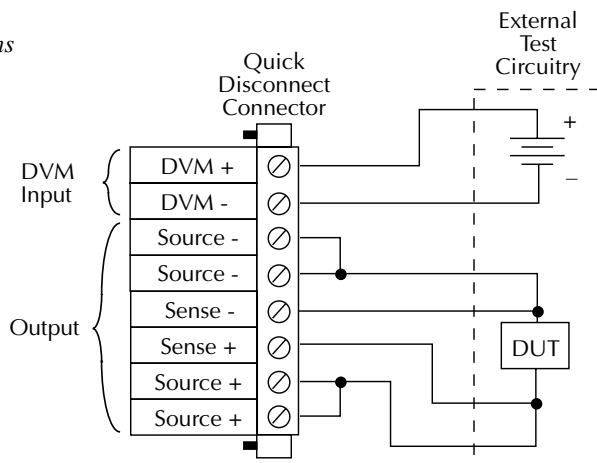

---

## Setting voltage and current values

Output voltage can be set from 0 to 20V, and there are three range selections for current (5 AMPS, 5 MILLIAMPS, and AUTO). The maximum current limit setting for the 5 AMPS and AUTO ranges is 5A. The maximum limit for the 5 MILLIAMPS range is 1A.

The current limit setting for the 5 AMPS and AUTO ranges is “remembered” by that range. For example, assume the current limit setting on the 5 AMPS range is 3A. Selecting the 5 MILLIAMPS range defaults the current limit setting to 1A since that is the maximum allowable setting on that range. Toggling back to the 5 AMPS range reinstates the 3A limit. If the current limit value on the 5 AMPS range is set to  $\leq 1A$ , the limit on the 5 MILLIAMPS range will be the same.

When the current limit is reached, the power supply can be set to either turn off (trip) or remain on. If set to remain on, the power supply output current will not exceed the set current limit value. See “Current limit” for details.

### Procedure to edit voltage and current values

The following procedure assumes that the appropriate current range is already selected. Remember, the maximum current limit setting on the 5 MILLIAMPS range is 1A.

**Editing keys** — Once in the Output Settings Mode, the four editing keys (◀, ▶, ▲, and ▼) are used to set values. Cursor position (blinking digit) is controlled by the ◀ and ▶ keys. With the cursor positioned on a digit, increment or decrement the value using the ▲ and ▼ keys.

Perform the following steps to edit voltage and current values:

*NOTE* When in the enhanced output response mode, the maximum output voltage setting is 15V. See “Enhanced output response” for details.

1. Press the SET key to select the Output Settings Mode. A blinking cursor appears in the voltage field of the display.
2. Use the ◀, ▶, ▲, and ▼ keys to key in the desired output voltage value and press SET. The blinking cursor moves to the current field of the display.
3. Use the ◀, ▶, ▲, and ▼ keys to key in the desired current limit and press SET to exit from the Output Settings Mode or front panel menu.

## Editing shortcuts

With the Output OFF, the following editing shortcuts can be used:

- Output voltage can be quickly set to the maximum value by incrementing the tens digit (MSD). Note that if the tens digit is zero, it is not displayed. Place the cursor to the left of the units digit.
- Output voltage can be quickly set to zero (0.000 V) by decrementing the first leading zero of the reading. If there is no leading zero, decrement the tens digit.
- Current limit on the 5A range can be quickly set to its maximum value by incrementing the units digit (MSD).
- Current limit on either range (5A or 5mA) can be quickly set to the minimum value (0.0001A) by decrementing the first leading zero of the reading. If there is no leading zero, decrement the units digit.

## Editing restrictions

With the Output ON, the following editing restrictions are in effect:

- You cannot increment a digit that would display a value that exceeds the maximum. For example, for the value 19.200V, you cannot increment the “1” or the “9” since the resultant value would exceed 20.000V.
- When decrementing a digit, only that digit and digits to the left are affected. The digits to the right of the cursor are not changed.

## NOTES

- *The SET key is active in any front panel menu or display mode. If not already in the Output Settings Mode, the SET key will select it.*
- *The V and I DACs are updated in real time. Therefore, if the output is on, the output is updated immediately when a value is altered.*
- *After pressing SET to exit the Output Settings Mode, the instrument returns to the previous display mode or front panel menu.*

# OPERATE

The OPERATE key is used to control the output of the power supply. This key toggles the output between on and off. While in one of the display modes, output ON or OFF is displayed in the upper right corner of the display. The key is active in any front panel menu or display mode. In menus, the state is not displayed.



---

## Output readback

With the ACTUAL V AND I display type selected (see “Display types”) and in the Readback Mode, the actual output voltage and current are measured and displayed. The Readback Mode is selected if there is no blinking cursor in the display. If in the Output Settings Mode (blinking cursor), keep pressing SET until the display returns to the Readback Mode.

There are three range selections for current readback: 5A, 5mA, or AUTO. With AUTO selected, the instrument automatically goes to the most sensitive range to perform the measurement. Range selection is performed from the CURRENT RANGE item of the MENU (see “MENU”).

The voltage and current readings that are displayed are controlled by the integration rate and the specified average readings count. In general, the integration rate defines the measurement speed of the instrument, and the average readings count specifies how many measurements are performed and averaged for each displayed reading. These aspects of operation are selected from the INTEGRATION RATE and AVERAGE READINGS items of the MENU. (See “MENU” for details.)

## Current limit

If the current limit is reached, the output will either turn off (trip) or stay on. The current limit mode (TRIP or LIM) is selected from the “CURRENT LIM MODE” item of the MENU. (See “MENU” for details.)

**LIM mode** — With the LIM mode selected, the output will remain on when the current limit is reached. The “LIM” message will appear on the lower line of the display, after the current reading indicator (A or mA). The message will clear when the limit condition is cleared.

The power supply can be taken out of current limit by decreasing the output voltage or increasing the current limit value. Note that increasing the current limit may compromise protection for the DUT.

While in current limit, the power supply is operating as a constant-current source. As long as the limit condition exists, the power supply output current will remain constant. Note that the output voltage is probably less than the programmed value when sourcing current, and probably greater than the programmed value when sinking current.

**TRIP mode** — With the TRIP mode selected, the output will turn off when the current limit is reached. The “TRIP” message will appear on the lower line of the display, after the current reading indicator (A or mA). The message will clear when the output is turned back on, assuming it does not trip again due to a current limit condition.

## Enhanced output response

The power supply has an enhanced output response mode to improve transient response to load changes. It improves transient recovery time and reduces the transient voltage drop. See Appendix A, “Specifications, Transient response 1000% load change,” for details.

With enhanced output response selected, maximum output voltage is reduced to 15V. When operating as a sink, maximum power with the enhanced output response mode selected is 15W.

The normal response mode is the RST default condition. Output response is checked or changed from the OUTPUT RESPONSE item of the MENU. Note that the output response mode cannot be changed while the output is on or the output voltage setting exceeds that response type limitation.

*NOTE* When displaying readings, the output response mode is also displayed. For the normal response mode, “NL” is displayed. For the enhanced response mode, “EL” is displayed.

## Independent voltage measurements (DVM)

The Model 2304A has an independent digital voltmeter (DVM) that can measure up to +20VDC. Connections for the DVM are shown in Figure 2-3. The DVM INPUT display type must be selected to use the DVM. (See “Display types.”)

## Pulse-current measurements

The Model 2304A can perform current measurements for pulsing loads. The built-in measurements include:

- Peak measured current — measures the peak (high) current of the pulse train.
- Idle measured current — measures the idle (low) current of the pulse train.
- Average transmit current — measures the average current of the pulse train.

The high, low, and average measurements of a pulse are illustrated in Figure 2-4. The high measurement is triggered on the rising edge of the pulse, and an integration is performed while the pulse is high for the time specified for the high measurement. The falling edge of the pulse triggers the low measurement, and an integration is performed for the time specified for the low measurement. An average measurement is triggered on the rising edge, and the integration covers both the high and low periods of the pulse as specified by the average measurement time settings.

*NOTE* Another measurement of pulse currents, digitization, is available over the bus. Refer to the :SENS:PCUR:SYNC:STAT command in Section 4 for details.

**Trigger level** — To avoid false pulse detection, you can use a trigger level of up to 5A. All pulses, noise, or other transients that are less than the set trigger level will be ignored.

**Trigger delay** — When a pulse is detected, there is a 25µsec code execution delay before the integration period begins. An additional trigger delay can be used to allow leading edge pulse overshoot to settle. The integration period will not start until the trigger delay period expires. Note that a large trigger delay will slow down power supply operation.

**Integration times** — The three integration time periods for pulse measurements can be set automatically or manually by the user. When the PULSE AUTO TIME operation is performed, the instrument measures the high and low periods of the detected pulse and sets appropriate integration times. The three integration times apply for all subsequent pulse measurements until another PULSE AUTO TIME is performed or the times are changed manually. The PULSE AUTO TIME feature can detect pulses in the 80µsec to 833msec range.

You can manually set the PULSE HIGH TIME, PULSE LOW TIME, and PULSE AVG TIME. In general, the longer the integration period, the more accurate the measurement. However, you must make sure that an integration period does not extend into the wrong portion of the pulse or into the next pulse. For example, if the pulse is high for 600µsec, the high integration time must be less than 600µsec. If not, you will integrate a low portion of the pulse, and the high pulse measurement will therefore be erroneous. Be sure to factor in trigger delay when determining integration times.

**Average readings count** — The average readings count specifies how many measurements (integrations) are performed and averaged for each displayed reading. For example, assume that the pulse average readings count is 10 and you are measuring PULSE HIGH. Each displayed reading will reflect the average of 10 peak pulse measurements.

*Figure 2-4  
Pulse-current  
measurement*

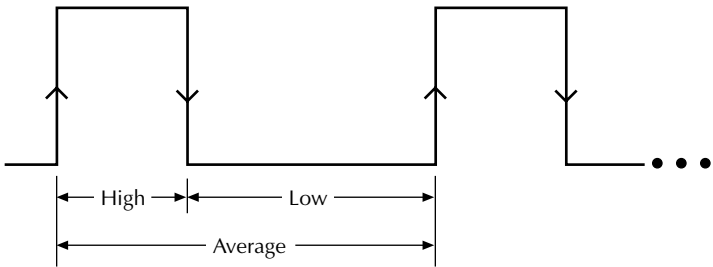

- ↑ High and average measurement triggered on leading edge of pulse
- ↓ Low measurement triggered on falling edge of pulse

## Pulse current digitization

The following discussion explains how to digitize a current waveform. A programming example at the end of this section demonstrates proper command sequence for pulse current digitization.

With pulse current digitization selected, readings are taken at a constant integration time of 33 $\mu$ sec across the pulse or pulse train. The message “DIGITIZE” is displayed instead of readings. Pulse current digitization is selected by disabling trigger synchronization:

```
SENS:PCUR:SYNC <b>
  <b> = OFF   Select pulse current digitization (trigger synchronization disabled).
      = ON    Select pulse current measurements (trigger synchronization enabled).
```

The commands to set the trigger level and trigger delay for pulse current measurements also apply for pulse current digitization. However, the trigger delay can be set for up to five seconds.

```
SENS:PCUR:SYNC:DEL <NRf>
  <NRf> = 0 to 5      Trigger digitization delay in seconds (10 $\mu$ sec steps).
```

Note that the “NO PULSE” message will be displayed if the pulse is not detected.

When the pulse is detected, the digitization process syncs up to the edge specified by the following command:

```
SENS:PCUR:MODE <name>
  <name> = HIGH or AVER   Sync up to rising edge of pulse.
          = LOW           Sync up to falling edge of pulse.
```

After any specified delay period expires, the instrument takes the number of readings specified by the average count command:

```
SENS:PCUR:AVER <NRf>
  <NRf> = 1 to 5000      Digitize 1 to 5000 readings.
```

**NOTE** *Although the integration time is 33 $\mu$ sec, some processing time is needed between readings. The time between readings, including integration and processing time, is about 278 $\mu$ sec.*

## Programming examples

### Pulse current measurements

The following command sequence will return the average of 10 peak pulse current measurements:

```

SENS:RANG 5           ' Select 5A range.
VOLT 15              ' Set output voltage to 15V.
CURR 0.75           ' Set current limit to 750mA.
OUTP ON             ' Turn output on.
SENS:PCUR:AVER 10   ' Set average count to 10.
SENS:PCUR:TIME:AUTO ' Set integration times automatically.
SENS:PCUR:SYNC:TLEV 0.1 ' Set trigger level to 100mA.
SENS:PCUR:SYNC:DEL 50e-3 ' Set trigger delay to 50msec.
SENS:FUNC "PCUR"    ' Select pulse current function.
SENS:PCUR:SYNC ON   ' Enable trigger synchronization.
SENS:PCUR:MODE HIGH ' Configure to measure peak pulse.
READ?               ' Trigger 10 measurement conversions and
                   ' return the average of those 10 conversions.

```

### Pulse current digitization

The following command sequence returns 3600 digitized readings. It will take approximately one second to perform the measurement process.

```

SENS:RANG 5           ' Select 5A range.
VOLT 15              ' Set output voltage to 15V.
CURR 0.75           ' Set current limit to 750mA.
OUTP ON             ' Turn output on.
SENS:PCUR:SYNC OFF  ' Disable trigger synchronization.
SENS:PCUR:AVER 3600 ' Set average count to 3600.
SENS:PCUR:SYNC:TLEV 0.1 ' Set trigger level to 100mA.
SENS:PCUR:SYNC:DEL 50e-3 ' Set trigger delay to 50msec.
SENS:FUNC "PCUR"    ' Select pulse current function.
READ:ARR?           ' Trigger and return 3600 readings.

```

## Pulse-current measurement procedure

The following steps summarize the procedure to perform pulse measurements:

1. From the PULSE CURRENT item of the MENU (see “MENU” for details), set the trigger level and delay, integration times, and average readings count.
2. Set the output voltage and current limit, and press OPERATE.
3. Press the DISPLAY key and select the PULSE CURRENT display type.
4. Use the ▲ or ▼ key to display the desired pulse measurement: PULSE HIGH, PULSE LOW, or PULSE AVG.

**NOTES** *If no pulses are detected, current will not be measured (i.e., ----A) and the “NO PULSE” message will be displayed. The “NO PULSE” message is displayed with dashes or the last valid pulse reading. Dashes are shown if the pulse-current measurement settings are not appropriate for detecting pulses. The last valid pulse reading is shown if the pulse disappears while taking background readings and no change in pulse settings was made.*

*Pulses are not detected with the output off. With the output on, pulses will not be detected if the trigger level is too low or too high. Perform the following procedure to find an appropriate trigger level. Make sure the voltage and current settings are appropriate for detecting pulses.*

## Determining correct trigger level

1. Turn on the output.
2. Select the PULSE CURRENT display type. If the trigger level is too low or too high, the “NO PULSE” message will be displayed. If pulse-current measurements are instead being displayed, the trigger level is valid. You can skip the rest of this procedure.
3. Go into the MENU, select PULSE CURRENT, and then TRIGGER LEVEL. (See “MENU” for details.)
4. Change the PULSE TRIG LEVEL and press ENTER. If the trigger level is still too low or too high, the “A/D PULSE TRIG NOT DETECTED” message will be displayed briefly. Note that it may take a few seconds for the message to appear.
5. If the message appeared, repeat step 4 until a valid trigger level is found.
6. Use the MENU key to back out of the menu structure and display pulse-current measurements.

## Long integration current measurements

Long integration is an average measurement of one or more pulses. The integration time period can be as long as 60 seconds. Since long integration is an average measurement, the integration time period should be a complete period, or integral number of periods for a pulse train.

A long integration measurement is accomplished by taking an integral number of integration cycles during the total measurement time. An integration cycle is the line cycle period (16.67ms for 60Hz) plus a small processing time.

The system calculates the number of integration cycles required based on the total time and rounds down to the nearest integer. Therefore, the actual measurement time can be slightly less than the requested measurement time by up to one line cycle time.

Long integration is a technique to extend the capabilities of the 2304A A/D circuit beyond its maximum integration time period. The A/D can measure pulses up to 833ms. To extend this time period for longer pulses, the long integration technique uses a filtered and sampled measurement of the waveform. This gives the 2304A the ability to measure signals with periods up to 60 seconds.

The filtering of the waveform adds some restrictions to the types of pulses being measured. If a pulse train has a high duty cycle, where the off time is less than 200ms, the first period of the measured waveform will not have settled to steady state, therefore it will be an inaccurate measurement. In all cases where the off or low time is less than 200ms, the filtered pulse will have reached steady state in the second cycle of the waveform and, therefore, can be accurately measured. In other words, to measure a periodic waveform with low times less than 200ms (high duty cycle), start measurements after the first period occurs. This is not a problem for one-shot pulses or for pulses with off times greater than 200ms.

The long integration measurement can be triggered to start on the rising or falling edge of a detected pulse. A third option, neither edge, lets you start the long integration measurement as soon as the Long Integration function is selected (assuming the output is on). This option does not need a valid trigger level to generate a reading. It will perform a measurement and produce a reading of the current even if a pulse is not present. Therefore, with NEITHER selected, the NO PULSE message will not appear on the display.

**Integration time** — The integration time period can be set automatically or manually by the user. The integration time can be as long as 60 seconds. For 60Hz power line frequency, the minimum integration time setting is 850msec. For 50Hz power line frequency, the minimum integration setting is 840msec.

Use AUTO TIME when you want to perform a long integration measurement of each pulse. When the AUTO TIME operation is performed, the instrument measures the time between two rising pulse edges and sets an appropriate integration time that will encompass the high and low periods of the pulse. This integration time applies for all subsequent long integration measurements until another AUTO TIME is performed or the times are changed manually.

If you want the integration period to encompass two or more pulses, you will have to set the integration time manually. However, you must make sure that the integration period does not extend into a pulse that you do not want measured. For example, if you want a long integration of two pulses, you must make sure that the set integration time does not extend into the third pulse.

**Trigger edge** — A pulse edge can be used to trigger the start of the measurement. Either a RISING pulse edge or a FALLING pulse edge can start the measurement. A third option is available if you do not want measurements controlled by pulse edges. With NEITHER selected, measurements start as soon as the Long Integration function is selected.

A pulse has to be detected before a RISING or FALLING pulse edge can trigger a long integration measurement. All pulses that are less than the specified trigger level are ignored (“Trigger level,” next entry). Note that pulse edges are ignored while a long integration is in process. The measurement will start immediately when the Long Integration function is selected. No pulse detection is needed if NEITHER trigger edge is selected.

**Trigger level** — Before a rising or falling pulse edge can trigger the start of a long integration, the pulse must first be detected. Trigger level specifies the minimum pulse level that will cause detection. For example, if the trigger level is set for 2A, pulses that are  $\geq 2A$  will be detected. Current pulses  $< 2A$  are ignored.

**Pulse timeout** — PULSE TIMEOUT applies only to long integration measurements that are configured to be triggered by rising or falling pulse edges. After the Long Integration function is selected, the instrument searches for a pulse. If a pulse is not detected within the specified time (pulse timeout), the “NO PULSE” message will be displayed. While the “NO PULSE” message is displayed, the instrument continues to search for a pulse. PULSE TIMEOUT can be set from 1.000 to 63.000 seconds.

With neither trigger edge selected, pulse timeout is not used and a pulse search is not conducted. Therefore, the “NO PULSE” message is never displayed. Measurements start as soon as the Long Integration function is selected, even if no pulse is present. It is the responsibility of the user to determine if a pulse was present when the measurement was made.



---

## Long integration measurement procedure

The following steps summarize the procedure to perform long integration current measurements:

1. From the LONG INTEGRATION item of the MENU, set integration time, pulse timeout, trigger edge, and trigger level (if appropriate).

**NOTE** *If you select AUTO TIME to set the integration time, a pulse timeout message “LONG INT TRIG NOT DETECTED” may occur if step 2 is not performed. However, it will not affect the AUTO TIME operation since the instrument will continue to search for a pulse to measure. If you prefer, you can perform the initial AUTO TIME after step 2.*

2. Set the output voltage and current limit, and press OPERATE.
3. Press the DISPLAY key and select the LONG INTEGRATION display type.
4. Observe the long integration readings on the display.

### General notes

- Make sure the voltage and current settings are appropriate for detecting pulses.
- If a pulse timeout occurs (no pulses detected), current will not be measured (i.e., ----A) and the “NO PULSE” message will be displayed. Pulses are not detected with the output off. With the output on, pulses will not be detected if the trigger level is too low or too high. Perform the “Determining correct trigger level” procedure to find an appropriate trigger level.
- While the “NO PULSE” message is displayed, the instrument continues to search for a pulse. The search can be terminated by pressing any front panel key. The “NOT TRIG” message replaces the “NO PULSE” message. To restart the search, press any arrow key while displaying long integration readings. The timeout or pulse detection will need to elapse before the display changes.
- To stop taking long integration readings, press any front panel key. As long as the instrument remains in the long integration display state, the measurement process can be resumed by pressing an arrow key. While readings are not being taken, the bottom line displays the last valid long integration reading, or dashes if no pulse was detected before being stopped.

### Determining correct trigger level

1. After selecting the appropriate voltage and current values, turn on the output.
2. Select the LONG INTEGRATION display type. If the trigger level is too low or too high, the “NO PULSE” message will be displayed. If long integration measurements are instead being displayed, the trigger level is valid. You can skip the rest of this procedure.
3. Go into the MENU, select LONG INTEGRATION, and then TRIGGER LEVEL. (See “MENU” for details.)

4. Adjust the trigger level and press ENTER. The unit starts looking for the pulse. If the trigger level is still too low or too high, the “LONG INT TRIG NOT DETECTED” message will be displayed briefly. Note that it may take as long as the timeout value for the message to appear.
5. If the message appeared, repeat step 4 until a valid trigger level is found.
6. Use the MENU key to back out of the menu structure and display long integration current measurements.

## Sink operation

When operating as a sink, the power supply is dissipating power rather than sourcing it. Figure 2-5 shows an example of how the power supply can be made to operate as a sink. An external source, whose voltage is higher than the programmed power supply voltage, is connected as shown. Current ( $I_{\text{sink}}$ ) flows into the positive (+) terminal of the power supply rather than out of it. Current readback is negative.

Sink operation allows the Model 2304A to be used as a constant current load. To function as a constant current load, the power supply must be in compliance (current limit). For example, the Model 2304A could function as a constant current load for a charger circuit that is to be tested. If a constant charging current of 1A is required, current limit for the Model 2304A would be set to 1A, and voltage would be set to a level that would keep it in compliance. For the test system shown in Figure 2-5, the Model 2304A will function as a constant current load as long as  $V/R$  of the charger circuit equals 1A or more.

**CAUTION** Exceeding current sink capacity (3A maximum) could cause damage to the power supply that is not covered by the warranty. With the enhanced output response mode selected, maximum sink current is 1A.

**Figure 2-5**  
Sink operation

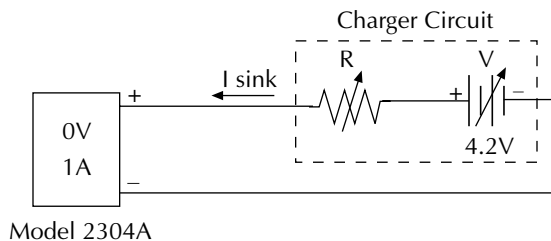

# Relay control

The Model 2304A can be used to control up to two external relays. Each control circuit is made up of an open-collector transistor that functions as a switch for the external relay circuit. Note that drive for each relay must be provided by an external DC voltage source.

Figure 2-6 shows the simplified control circuit in the Model 2304A and shows a typical configuration to control two external relays. As shown in the illustration, voltage applied to the Model 2304A must not exceed 15VDC and current for each relay circuit must not exceed 150mADC.

Also note that a protection diode is required for each relay circuit. The protection diode provides a current dissipation path for fly-back voltage from the relay coil that occurs when the control circuit is opened. Without the diode, the high fly-back voltage could damage the Model 2304A.

**CAUTION** To prevent damage to the Model 2304A that is not covered by the warranty, adhere to the following precautions:

- ALWAYS use a protection diode for each relay circuit as shown in Figure 2-6.
- Do not exceed the voltage and current limits of the RELAY CONTROL port of the Model 2304A (15VDC and 150mADC).

**Figure 2-6**  
Relay control

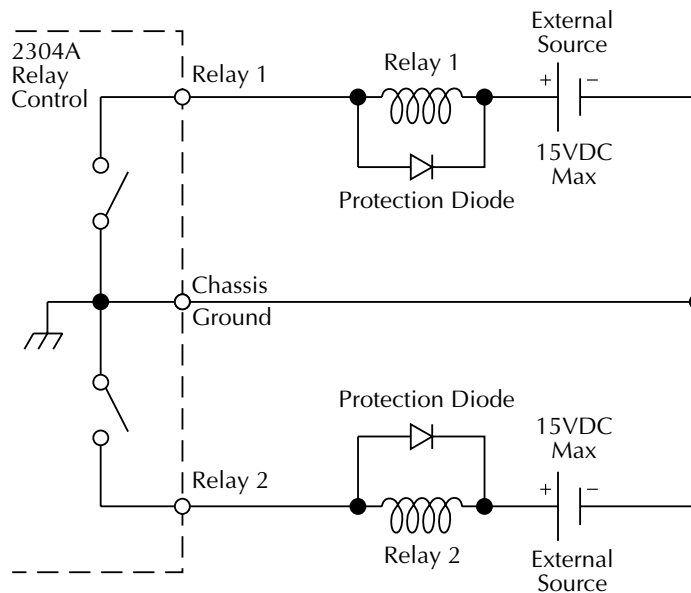

## Connections

An external relay circuit is connected to the Model 2304A via the miniature phono jack on the rear panel (labeled RELAY CONTROL 15VDC MAX). The required three-conductor phono plug that mates to the phono jack is shown in Figure 2-7. The illustration provides terminal identification for the three conductors of the plug. This phono plug is available from Switchcraft, Inc. (See Table 2-2 for Switchcraft Connection Accessories.)

Also available from Switchcraft is a three-conductor patch cord that is terminated with a phono plug on each end. The patch cord is available in various lengths from 0.5 ft to 6 ft. The part numbers for the patch cords are listed in the table for Switchcraft Connection Accessories. You can remove (cut) one of the phono plugs from the patch cord. One end of the modified patch cord plugs into the phono jack on the Model 2304A, and the unterminated end is hard-wired to the external relay circuit(s).

Another alternative is to wire the external relay circuit(s) to a second phono jack. You can then use an unmodified patch cord to connect the relay circuit(s) to the Model 2304A. The part number for the phono jack is listed in the table for Switchcraft Connection Accessories.

**Figure 2-7**  
*Miniature phono  
plug*

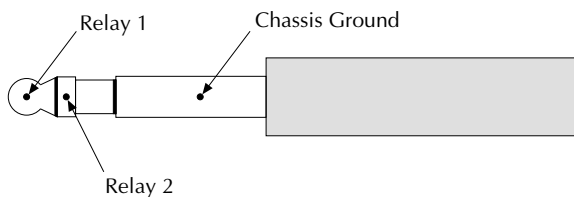

**Table 2-2**  
Switchcraft connection accessories

Part number	Description
TT253	Miniature Phono Plug (3-conductor)
UJ2B	Miniature Phono Jack (3-conductor)
	Patch Cords (3-conductor):
TT741	0.5 ft patch cord
TT742	1 ft patch cord
TT744	2 ft patch cord
TT746	3 ft patch cord
TT747	4 ft patch cord
TT748	5 ft patch cord
TT749	6 ft patch cord

Switchcraft, Inc.  
5555 N. Elston Ave.  
Chicago, IL 60630  
Phone: 312-631-1234  
FAX: 312-792-2129

## Controlling the relays

From the front panel, external relays are controlled from the OUTPUT RELAY ONE and OUTPUT RELAY TWO items of the MENU. (See “MENU” for details.)

1. From the MENU, select the relay that you want to control: OUTPUT RELAY ONE or OUTPUT RELAY TWO.
2. Select the desired relay control option: ONE or ZERO. Selecting ONE closes the relay control circuit to energize the relay, while ZERO opens the circuit to de-energize the relay.

**NOTE** Both external relays can be energized at the same time.

Over the bus, relay control is provided by the :OUTPut:RELAy1 and :OUTPut:RELAy2 commands. Similar to front panel operation, the parameter options for these commands are ONE and ZERO. See OUTPut command summary in Section 4 for details.

# MENU

Many aspects of operation are configured from the MENU that is summarized in Table 2-3. Use the following rules to navigate through the menu structure. Details about the menu items follow the navigation rules (see “MENU structure”).

**NOTE** The MENU key is used to access the menu structure. However, if in remote for IEEE-488 bus operation (“R” displayed below “ON/OFF”) the MENU key returns the instrument to LOCAL operation.

**Table 2-3**  
MENU structure

Menu item	Description
GPIB address	Set primary address (0 to 30).
Current range	Select current range (5A, 5mA, or AUTO).
Integration rate	Set integration rate in NPLC (0.01 to 10).
Average readings	Set average reading count (1 to 10).
Save setup	Save present setup in memory (SAV0-SAV4).
Recall setup	Recall setup from memory (RST or SAV0-SAV4).
Power on setup	Select power-on setup (RST, SAV0 - SAV4).
Calibrate unit	Calibrate Model 2304A (see Calibration Manual).
Current lim mode	Select current limit mode (Limit or Trip).
Output response	Select output response (Normal or Enhanced).
Output relay one	Close (ONE) or open (ZERO) relay control circuit 1.
Output relay two	Close (ONE) or open (ZERO) relay control circuit 2.
Revision number	Display firmware revision levels.
Serial number	Display serial number of the Model 2304A.
Pulse current	Pulse-current configuration:
High time	Set high time integration rate (in $\mu$ sec).
Low time	Set low time integration rate (in $\mu$ sec).
Average time	Set average time integration rate (in $\mu$ sec).
Auto time	Set pulse integration rates automatically.
Average readings	Set average reading count (1 to 100).
Trigger delay	Set trigger delay in seconds (0 to 100msec).
Trigger level	Set trigger level (0 to 5A).
Long Integration	Long integration configuration:
Integration time	Manually set integration time (up to 60sec).
Auto time	Automatically set integration time.
Pulse timeout	Set the “NO PULSE” timeout period (1 to 63sec).
Trigger edge	Select trigger edge (rising, falling, or neither).
Trigger level	Set trigger level (0 to 5A).

## Rules to navigate MENU

- The MENU is accessed by pressing the MENU key.
- Use the ▲ and ▼ edit keys to display the primary menu items. Primary menu items are denoted by bullets (•) in the MENU structure.
- A displayed primary menu item is selected by pressing ENTER. With PULSE CURRENT or LONG INTEGRATION selected, use the ▲ and ▼ edit keys to display the secondary items and press ENTER to select the displayed item.
- Settings and selections for a menu item are displayed using the edit keys (◀, ▶, ▲, and ▼):
  - For a setting, use ▶ or ▶ to place the cursor on the appropriate digit, and use ▲ and ▼ to increment and decrement the value.
  - For a selection, use ▲ or ▼ to display the desired option.
- With the desired setting or selection displayed, press ENTER. Pressing MENU will cancel the edit operation.
- Use the MENU key to back out of the MENU structure.

## MENU structure

- **GPIB ADDRESS** — Use to set the primary address for the IEEE-488 bus (0 to 30). At the factory, the address is set to 16. Do not select an address that conflicts with the address of the controller or any other instrument on the bus. The address is displayed on power-up.
- **CURRENT RANGE** — Use to select the current readback measurement range (5 AMPS, 5 MILLIAMPS, or AUTO). With AUTO selected, the instrument automatically goes to the most sensitive range to perform the measurement.

*NOTE Taking pulse current and long integration measurements sets the current range to 5A and has no effects on the auto state.*

- **INTEGRATION RATE** — Use to set the reading rate for voltage, current, and DVM measurements (0.01 to 10). The reading rate is specified as a parameter based on the number of power line cycles (NPLC), where 1 PLC for 60Hz is 16.67msec (1/60). In general, the fastest integration time (0.01 PLC) results in increased reading noise. The slowest integration time (10 PLC) provides the best common-mode and normal-mode rejection. In-between settings are a compromise between speed and noise.

*NOTE The integration rates for pulse current and long integration measurements are set from PULSE CURRENT and LONG INTEGRATION menu items.*

- **AVERAGE READINGS** — Use to set the average reading count (1 to 10) for voltage, current, and DVM measurements. This count specifies the number of measurement conversions to average for each reading. For example, with a reading count of 5, each displayed reading will be the average of five measurement conversions.

**NOTE** *The average reading count for pulse-current measurements is set from the PULSE CURRENT item of the menu.*

- **SAVE SETUP** — Saves the present power supply setup to a memory location (SAV0 to SAV4). Note that OPERATE ON cannot be saved.
- **RECALL SETUP** — Returns the power supply to a setup saved in memory (RST or SAV0 to SAV4). The Operate state is always recalled as OFF.
- **POWER-ON SETUP** — Select setup to use at power-up (RST or SAV0-SAV4).
- **CALIBRATE UNIT** — Use to calibrate the Model 2304A. Refer to the Calibration Manual for details.
- **CURRENT LIM MODE** — Use to select the current limit mode (LIM or TRIP). With LIM selected, output current will not exceed the set limit value. It will clamp at the limit value. With TRIP selected, the output will turn off when the current limit is reached. See “Current limit” for details.
- **OUTPUT RESPONSE** — Use to check or select the output response mode (NORMAL or ENHANCED). In the NORMAL mode, the standard output characteristics are in effect. In general, the ENHANCED mode is used to improve transient response to load changes. However, the maximum output voltage setting in this mode is 15V. The output response mode cannot be changed when the output is on or when the output voltage setting exceeds the maximum voltage limitation. See “Enhanced output response” for more information.
- **OUTPUT RELAY ONE** — Use to control the circuit for relay 1. Selecting ONE closes the relay control circuit to energize the relay, while ZERO opens the circuit to de-energize the relay.
- **OUTPUT RELAY TWO** — Use to control the circuit for relay 2. Selecting ONE closes the relay control circuit to energize the relay, while ZERO opens the circuit to de-energize the relay.
- **REVISION NUMBER** — Displays the firmware revision level for the microcontroller and the display.
- **SERIAL NUMBER** — Displays the serial number of the Model 2304A.
- **PULSE CURRENT** — Use the following menu items to configure pulse-current measurements. See “Pulse-current measurements” for details on these measurements.
  - **HIGH TIME** — Use to set the integration period (in  $\mu\text{sec}$ ) for high pulse-current measurements.
  - **LOW TIME** — Use to set the integration period (in  $\mu\text{sec}$ ) for low pulse-current measurements.
  - **AVERAGE TIME** — Use to set the integration period (in  $\mu\text{sec}$ ) for average pulse-current measurements.
  - **AUTO TIME** — Use to automatically set the integration times for high, low, and average pulse-current measurements. These times are based on detecting the pulse and remain until another AUTO TIME is performed or the times are manually changed.



- **AVERAGE READINGS** — Use to set the average reading count (1 to 100) for pulse-current measurements. This count specifies the number of measurements (integrations) to average for each reading. For example, with a reading count of 10, each displayed reading will reflect the average of 10 pulse-current measurements.
- **TRIGGER DELAY** — Use to specify additional trigger delay (0 to 100msec in 10 $\mu$ sec steps). See “Pulse-current measurements, Trigger delay” for details.
- **TRIGGER LEVEL** — Use to set the trigger level (0 to 5A in 5mA steps). Pulses less than the specified level are not detected. There are approximately 10mA of trigger hysteresis built into the hardware. If a pulse does not exceed this level, trigger detection will not occur. See “Pulse-current measurements, Determining correct trigger level” to set a valid trigger level.
- **LONG INTEGRATION** — Use the following menu items to configure long integration current measurements. See “Long integration current measurements” for details on these measurements.
  - **INTEGRATION TIME** — Manually set the long integration time. For 60Hz power line frequency, integration can be set from 850msec to 60sec. For 50Hz power line frequency, integration can be set from 840msec to 60sec.
  - **AUTO TIME** — Use to automatically set the integration time. When the AUTO TIME operation is performed, the instrument measures the time between two rising pulse edges and sets an appropriate integration time that will encompass the high and low periods of the pulse.
  - **PULSE TIMEOUT** — Set pulse timeout (from 1 to 63 seconds) for long integration measurements that are configured to be triggered by rising or falling pulse edges. If a pulse is not detected within the specified time (pulse timeout), the “NO PULSE” message will be displayed. While the “NO PULSE” message is displayed, the instrument continues to search for a pulse.
  - **TRIGGER EDGE** — A pulse edge can be used to trigger the start of the measurement. Select RISING to use a rising pulse edge to start the measurement. Select FALLING to use a falling pulse edge to start the measurement. A third option is available if you do not want measurements controlled by pulse edges. With NEITHER selected, measurements will start as soon as the Long Integration function is selected. Note that a pulse has to be detected before a rising or falling pulse edge can trigger a long integration measurement (see “TRIGGER LEVEL” below).
  - **TRIGGER LEVEL** — Before a rising or falling pulse edge can trigger the start of a long integration, the pulse must first be detected. Trigger level specifies the minimum pulse level that will cause detection. The trigger level can be set from 0 to 5A (in 5mA steps).

**3**

# GPIB Operation

---

## Introduction

The GPIB bus is the IEEE-488 instrumentation data bus with hardware and programming standards originally adopted by the IEEE (Institute of Electrical and Electronic Engineers) in 1975. The Model 2304A conforms to these standards:

- IEEE-488-1987.1
- IEEE-488-1987.2

These standards define a syntax for sending data to and from instruments, how the instrument interprets this data, what registers should exist to record the state of the instrument, and a group of common commands.

- SCPI 1995.0 (Standard Commands for Programmable Instruments)

This standard defines a command language protocol. It goes one step further than IEEE-488-1987.2 and defines a standard set of commands to control every programmable aspect of the instrument.

## GPIB bus connections

To connect the Model 2304A to the GPIB bus, use a cable equipped with standard IEEE-488 connectors. The IEEE connector on the Model 2304A is shown in Figure 3-1.

**Figure 3-1**  
IEEE-488  
connector

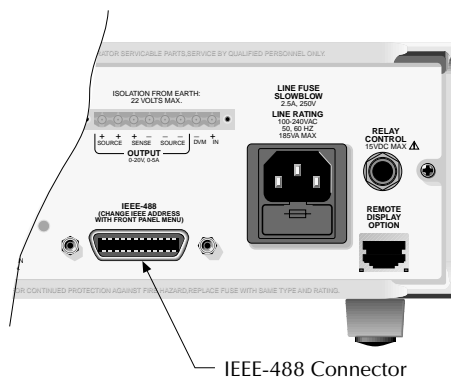

**NOTE** To minimize interference caused by electromagnetic radiation, use only shielded IEEE-488 cables. Available shielded cables from Keithley are Models 7007-1 and 7007-2.

For a multi-unit test system, you can daisy-chain the instruments to the controller by connecting an IEEE cable from one unit to another.

Most controllers are equipped with an IEEE-488 style connector, but a few may require a different type of connecting cable. See the controller's instruction manual if it is not equipped with an IEEE-488 style connector.

---

## Primary address

The Model 2304A ships from the factory with a GPIB address of 16. You can set the address to a value of 0 to 30. Do not assign the same address to another device or to a controller that is on the same GPIB bus.

The primary address can be checked and/or changed from the front panel MENU as follows:

1. Press the MENU key on the front panel.
2. Use the ▲ or ▼ to display GPIB ADDRESS, and press ENTER.
3. To change the address use the ◀, ▶, ▲, and ▼ keys to set the address value and press ENTER. Otherwise, use the MENU key to back out of the menu structure.
4. Use the MENU key to back out of the menu structure.

*NOTE* The present address is displayed on power-up.

## QuickBASIC 4.5 programming

Programming examples are written in Microsoft QuickBASIC 4.5 using the Keithley KPC-488.2 (or Capital Equipment Corporation) IEEE interface and the HP-style Universal Language Driver (CECHP).

### Universal language driver installation

Before any programming example can be run, the Universal Language Driver must first be installed. To install the driver, enter the CECHP command at the DOS prompt.

If you include the CECHP command in your AUTOEXEC.BAT file, the driver will automatically be installed every time you turn on your computer.

### Using program fragments

Program fragments are used to demonstrate proper programming syntax. Only a fragment of the whole program is used to avoid redundancy.

At the beginning of each program, driver files must be opened. The input terminator should be set for CRLF. For example:

```
OPEN "ieec" FOR OUTPUT AS #1
OPEN "ieec" FOR INPUT AS #2
PRINT #1, "interm crlf"
```

A typical program fragment includes an OUTPUT command and an ENTER command. The OUTPUT command sends a program message (command string) to the Model 2304A. If the program message includes a query command, then the ENTER command is required to get the response message from the Model 2304A. The ENTER command addresses the Model 2304A

to talk. The following example program fragment demonstrates how OUTPUT and ENTER commands are used. Note that the commands assume address 16, which is the factory-set address of the Model 2304A.

```
PRINT #1, "output 16; :read?"
PRINT #1, "enter 16"
```

If you wish to display the response message on the CRT, the computer will have to read the message and then “print” it to the CRT display as follows:

```
LINE INPUT #2, A$
PRINT A$
```

The following programming example shows how the above statements are used together. The program fragment is shown in bold typeface.

```
OPEN "ieee" FOR OUTPUT AS #1   ' Open driver
OPEN "ieee" FOR INPUT AS #2   ' Open driver
PRINT #1, "interm crlf"      ' CRLF terminator
PRINT #1, "output 16; :read?" ' Trigger and return one reading
PRINT #1, "enter 16"       ' Get response message
LINE INPUT #2, A$           ' Read response message
PRINT A$                   ' Display message
```

## General bus commands

General commands are those commands, such as DCL, that have the same general meaning regardless of the instrument. Table 3-1 lists the general bus commands along with the programming statement for each command, which uses the Keithley KPC-488.2 IEEE interface and the HP-style Universal Language Driver. Note that the commands requiring that the primary address be specified assume that the address is the factory-set address of 16.

**Table 3-1**  
*General bus commands and associated statements*

Command	Programming statement	Effect on Model 2304A
REN	REMOTE 16	Goes into effect when next addressed to listen.
IFC	ABORT	Goes into talker and listener idle states.
LLO	LOCAL LOCKOUT	LOCAL key locked out.
GTL	LOCAL 16	Cancel remote; restore front panel operation for the 2304A.
	LOCAL	Cancel remote; restore front panel operation for all devices.
DCL	CLEAR	Returns all devices to known conditions.
SDC	CLEAR 16	Returns Model 2304A to known conditions.
GET	TRIGGER 16	Trigger a single reading.
SPE, SPD	SPOLL 16	Serial polls the Model 2304A.

## REN (remote enable)

The remote enable command is sent to the Model 2304A by the controller to set up the instrument for remote operation. Generally, the instrument should be placed in the remote mode before attempting to program it over the bus. Setting REN true does not place the instrument in the remote state. The instrument must be addressed to listen after setting REN true before it goes into remote.

*NOTE* When in remote, the "R" character is displayed on the lower right corner of the display. It blinks as a solid block character.

Note that the instrument need not be in remote to be a talker.

### Program fragment

```
PRINT #1, "remote 16"           ' Place the Model 2304A in remote; display "R" (for remote)
```

Note that all front panel controls except for LOCAL are inoperative while the instrument is in remote. You can restore normal front panel operation by pressing the LOCAL key.

## IFC (interface clear)

The IFC command is sent by the controller to place the Model 2304A in the local, talker, listener idle states. Note that this command does not affect the status of the instrument; settings, data, and event registers are not changed.

To send the IFC command, the controller need only set the IFC line true for a minimum of 100µs.

### Program fragment

```
PRINT #1, "output 16; *idn?"    ' Send query command
PRINT #1, "enter 16"           ' Read data; turn on TALK annunciator
SLEEP 3                         ' Wait 3 seconds
PRINT #1, "abort"              ' Talker idle state; turn off TALK annunciator
```

## LLO (local lockout)

Use the LLO command to prevent local operation of the instrument. After the unit receives LLO, all of its front panel controls except the POWER are inoperative. In this state, pressing LOCAL will not restore control to the front panel. The GTL command restores control to the front panel. Cycling power will also cancel local lockout.

### Program fragment

```
PRINT #1, "remote 16"           ' Place 2304A in remote
PRINT #1, "local lockout"       ' Lock out front panel (including LOCAL key)
SLEEP 6                         ' Wait 6 seconds
PRINT #1, "local 16"           ' Restore front panel operation
```

## GTL (go to local)

Use the GTL command to put a remote-mode instrument into local mode. The GTL command also restores front panel key operation.

### Program fragment

```
PRINT #1, "remote 16"      ' Place 2304A in remote
SLEEP 3                    ' Wait 3 seconds
PRINT #1, "local 16"      ' Place 2304A in local mode
```

## DCL (device clear)

Use the DCL command to clear the GPIB interface and return it to a known state. Note that the DCL command is not an addressed command, so all instruments equipped to implement DCL will do so simultaneously.

When the Model 2304A receives a DCL command, it clears the Input Buffer and Output Queue, cancels deferred commands, and clears any command that prevents the processing of any other device command. A DCL does not affect instrument settings and stored data.

### Program fragment

```
PRINT #1, "clear"          ' Clear all devices
```

## SDC (selective device clear)

The SDC command is an addressed command that performs essentially the same function as the DCL command. However, since each device must be individually addressed, the SDC command provides a method to clear only selected instruments instead of clearing all instruments simultaneously, as is the case with DCL.

### Program fragment

```
PRINT #1, "clear 16"      ' Clear 2304A
```

## GET (group execute trigger)

GET is a GPIB trigger that is used to trigger and display a single reading.

### Program fragment

```
PRINT #1, "trigger 16"    ' Trigger and display one reading 2304A
                           from over the bus
```

This sends IEEE-488 commands UNT UNL LISTEN 16 GET. When the command is executed, the trigger event occurs. (The command TRIGGER just sends GET. Any other listeners are triggered when the command is executed.)

## SPE, SPD (serial polling)

Use the serial polling sequence to obtain the Model 2304A serial poll byte. The serial poll byte contains information about internal functions (see “Status structure”). Generally, the serial polling sequence is used by the controller to determine which of several instruments has requested service with the SRQ line. However, the serial polling sequence may be performed at any time to obtain the status byte from the Model 2304A.

### Program fragment

```
PRINT #1, "spoll 16"      ' Serial poll the 2304A
INPUT #2, S               ' Read serial poll byte
PRINT S                  ' Display the decimal value of the serial poll byte
```

## Front panel aspects of GPIB operation

The following paragraphs describe aspects of the front panel that are part of GPIB operation, including the remote operation indicator, LOCAL key, and messages.

### Remote indicator and LOCAL key

When the Model 2304A is in the remote state, the “R” character is displayed in the bottom right corner of the display. It blinks as a solid block character. “R” does not necessarily indicate the state of the REM line, as the instrument must be addressed to listen with REM true before the “R” indicator turns on.

When the instrument is in remote, all front panel keys, except for the LOCAL key, are locked out. The LOCAL key cancels the remote state and restores local operation of the instrument. Pressing the LOCAL key also turns off the “R” indicator and returns the display to normal if a user-defined message was displayed.

If the LLO (Local Lockout) command is in effect, the LOCAL key is also inoperative.

### Error and status messages

See Table 3-2 for a list of error and status messages associated with IEEE-488 programming. The instrument can be programmed to generate an SRQ, and command queries can be performed to check for specific error conditions.



**Table 3-2**  
*Status and error messages*

<b>Number</b>	<b>Description</b>	<b>Event</b>
-440	Query unterminated after indefinite response	EE
-430	Query deadlocked	EE
-420	Query unterminated	EE
-410	Query interrupted	EE
-363	Input buffer overrun	SYS
-350	Queue overflow	SYS
-330	Self-test failed	EE
-314	Save/recall memory lost	EE
-315	Configuration memory lost	EE
-260	Expression error	EE
-241	Hardware missing	EE
-230	Data corrupt or stale	EE
-225	Out of memory	EE
-224	Illegal parameter value	EE
-223	Too much data	EE
-222	Parameter data out of range	EE
-221	Settings conflict	EE
-220	Parameter error	EE
-200	Execution error	EE
-178	Expression data not allowed	EE
-171	Invalid expression	EE
-170	Expression error	EE
-161	Invalid block data	EE
-160	Block data error	EE
-158	String data not allowed	EE
-154	String too long	EE
-151	Invalid string data	EE
-150	String data error	EE

EE = error event

SYS = system error event

*Table 3-2 (cont.)  
Status and error messages*

<b>Number</b>	<b>Description</b>	<b>Event</b>
-148	Character data not allowed	EE
-144	Character data too long	EE
-141	Invalid character data	EE
-140	Character data error	EE
-124	Too many digits	EE
-123	Exponent too large	EE
-121	Invalid character in number	EE
-120	Numeric data error	EE
-114	Header suffix out of range	EE
-113	Undefined header	EE
-112	Program mnemonic too long	EE
-111	Header separator error	EE
-110	Command header error	EE
-109	Missing parameter	EE
-108	Parameter not allowed	EE
-105	GET not allowed	EE
-104	Data type error	EE
-103	Invalid separator	EE
-102	Syntax error	EE
-101	Invalid character	EE
-100	Command error	EE
+000	No error	SE
+101	Operation complete	SE
+301	Reading overflow	SE
+302	Pulse trigger detection timeout	SE
+306	Reading available	SE
+310	Buffer full	SE

EE = error event

SE = status event

**Table 3-2 (cont.)**  
*Status and error messages*

Number	Description	Event
+320	Current Limit event	SE
+321	Current Limit tripped event	SE
+322	Heat sink shutdown event	SE
+323	Power supply shutdown event	SE
	Calibration messages:	
+404	Volt full scale cal prepare error	EE
+405	Volt full scale cal output error	EE
+406	Volt full scale cal meas error	EE
+407	DVM full scale cal meas error	EE
+409	5 Amp source cal prepare error	EE
+410	5 Amp source cal output error	EE
+411	5 Amp source cal measure error	EE
+412	5 mA source cal prepare error	EE
+413	5 mA source cal measure error	EE
+438	Date of Calibration not set	EE
+440	Gain-aperture correction error	EE
+500	Calibration data invalid	EE
+510	Reading buffer data lost	EE
+511	GPIB address lost	EE
+512	Power-on state lost	EE
+514	DC Calibration data lost	EE
+515	Calibration dates lost	EE
+522	GPIB communication data lost	EE
+610	Questionable calibration	SE
+900	Internal system error	EE

EE = error event

SE = status event

# Status structure

Figure 3-2 shows the status structure for the Model 2304A. Instrument events such as errors are monitored and manipulated by four status register sets. Notice that these status register sets feed directly into the Status Byte Register. More detailed illustrations of these register sets are provided by Figures 3-3 through 3-6.

**Figure 3-2**  
Model 2304A  
status register  
structure

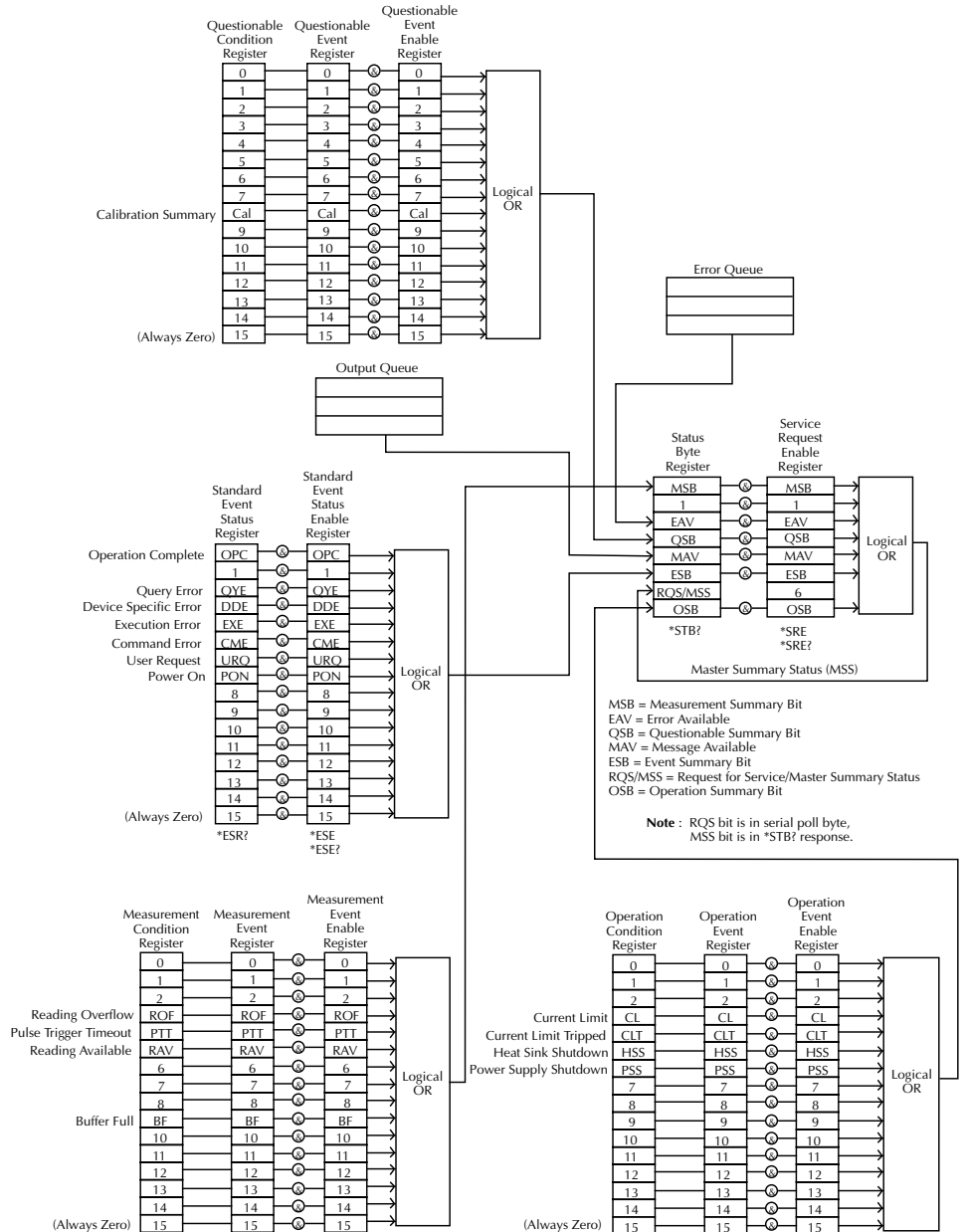

## Condition registers

As Figure 3-2 shows, all status register sets have a condition register. A condition register is a real-time, read-only register that constantly updates to reflect the present operating conditions of the instrument. For example, if the power supply is in current limit, bit B3 (Lim) of the Operation Condition Register is set. When the current limit condition clears, bit B3 clears.

Use the :CONDITION? query commands in the STATus Subsystem to read the condition registers. See Section 4 for more information.

## Event registers

As Figure 3-2 shows, each status register set has an event register. An event register is a latched, read-only register whose bits are set by the corresponding condition register. Once a bit in an event register is set, it remains set (latched) until the register is cleared by a specific clearing operation. The bits of an event register are logically ANDed with the bits of the corresponding enable register and applied to an OR gate. The output of the OR gate is applied to the Status Byte Register.

Use the \*ESR? Common Command to read the Standard Event Register. All other event registers are read using the :EVENT? query commands in the STATus Subsystem. See Section 5 for more information.

An event register is cleared when it is read. The following operations clear all event registers:

- Cycling power
- Sending \*CLS

## Enable registers

As Figure 3-2 shows, each status register set has an enable register. An enable register is user programmed and serves as a mask for the corresponding event register. An event bit is masked when the corresponding bit in the enable register is cleared (0). When masked, a set bit in an event register cannot set a bit in the Status Byte Register ( $1 \text{ AND } 0 = 0$ ).

To use the Status Byte Register to detect events (i.e., serial poll), you must unmask the events by setting the appropriate bits of the enable registers.

To program and query the Standard Event Status Register, use the \*ESE and \*ESE? Common Commands, respectively. All other enable registers are programmed and queried using the :ENABLE and :ENABLE? commands in the STATus Subsystem. See Section 4 for more information.

An enable register is not cleared when it is read. The following operations affect the enable registers:

- Cycling power — Clears all enable registers
- :STATus:PRESet — Clears the following enable registers:
  - Operation Event Enable Register
  - Questionable Event Enable Register
  - Measurement Event Enable Register
- \*ESE 0 — Clears the Standard Event Status Enable Register.

## Queues

The Model 2304A uses two queues, which are first-in, first-out (FIFO) registers:

- **Output Queue** — used to hold reading and response messages.
- **Error Queue** — used to hold error and status messages.

The Model 2304A status model (Figure 3-2) shows how the two queues are structured with the other registers.

### Output Queue

The output queue holds data that pertains to the normal operation of the instrument. For example, when a query command is sent, the response message is placed in the Output Queue.

When data is placed in the Output Queue, the Message Available (MAV) bit in the Status Byte Register sets. A data message is cleared from the Output Queue when it is read. The Output Queue is considered cleared when it is empty. An empty Output Queue clears the MAV bit in the Status Byte Register.

Read a message from the Output Queue by addressing the Model 2304A to talk after the appropriate query is sent.

### Error Queue

The Error Queue holds error and status messages. When an error or status event occurs, a message that defines the error/status is placed in the Error Queue. This queue will hold up to ten messages.

When a message is placed in the Error Queue, the Error Available (EAV) bit in the Status Byte Register is set. An error message is cleared from the Error/Status Queue when it is read. The Error Queue is considered cleared when it is empty. An empty Error Queue clears the EAV bit in the Status Byte Register. Read an error message from the Error Queue by sending either of the following SCPI query commands and then addressing the Model 2304A to talk:

- `:SYSTem:ERRor?`
- `:STATus:QUEue?`

Messages in the Error Queue are stored in a first-in, first-out (FIFO) manner. See Section 4 for complete information about reading error messages.

**Figure 3-3**  
Standard event status

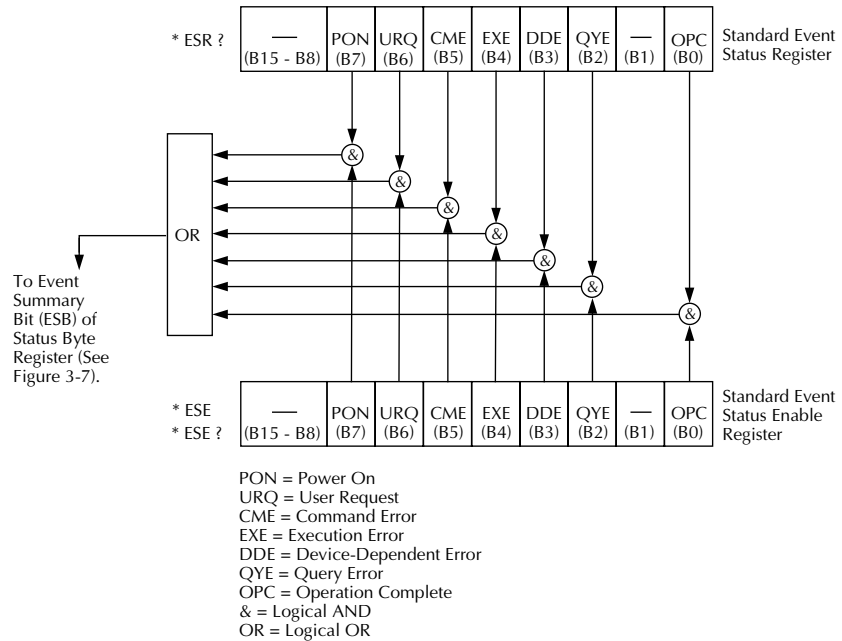

**Figure 3-4**  
Operation event status

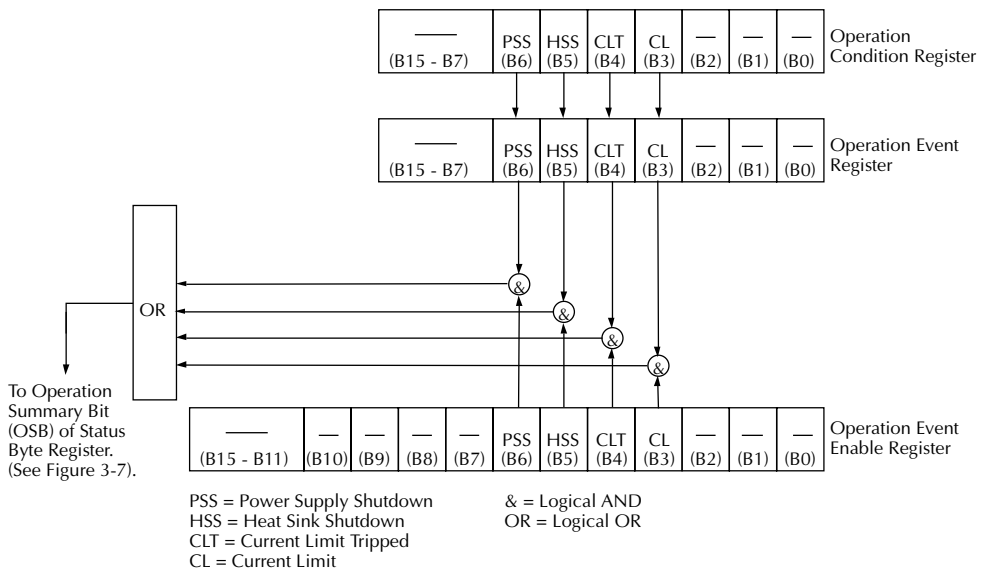

**Figure 3-5**  
*Measurement event status*

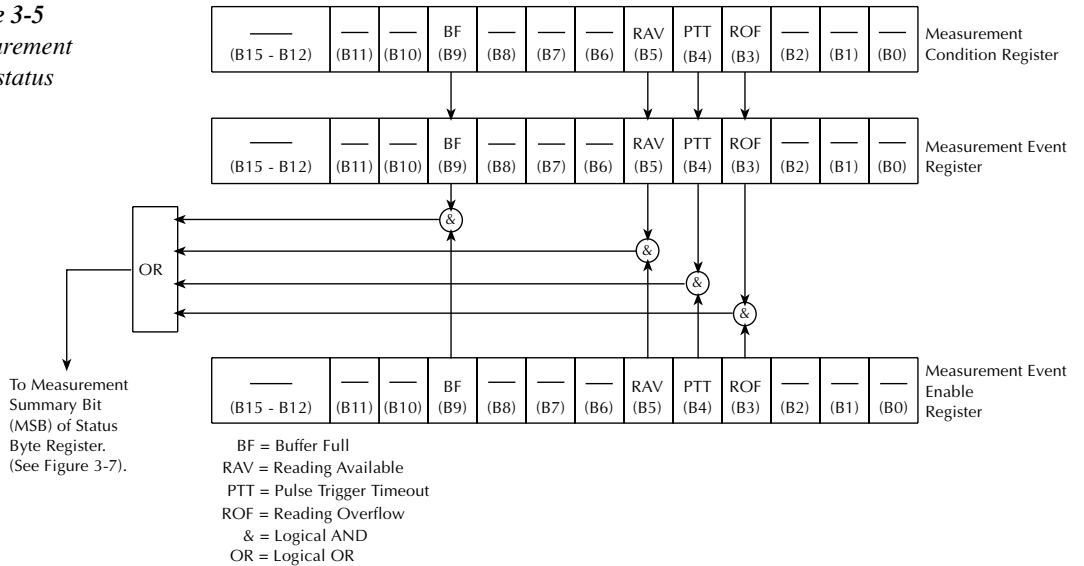

**Figure 3-6**  
*Questionable event status*

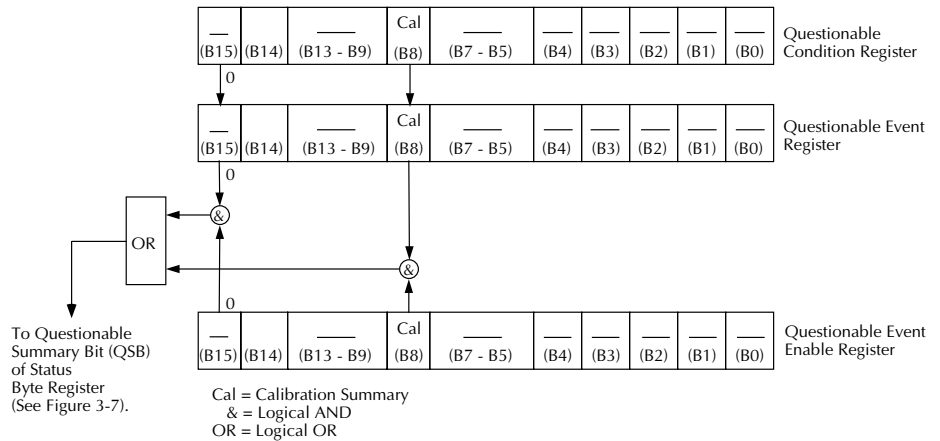



## Status Byte and Service Request (SRQ)

Service request is controlled by two 8-bit registers: the Status Byte Register and the Service Request Enable Register. Figure 3-7 shows the structure of these registers.

**Figure 3-7**  
Status byte and service request (SRQ)

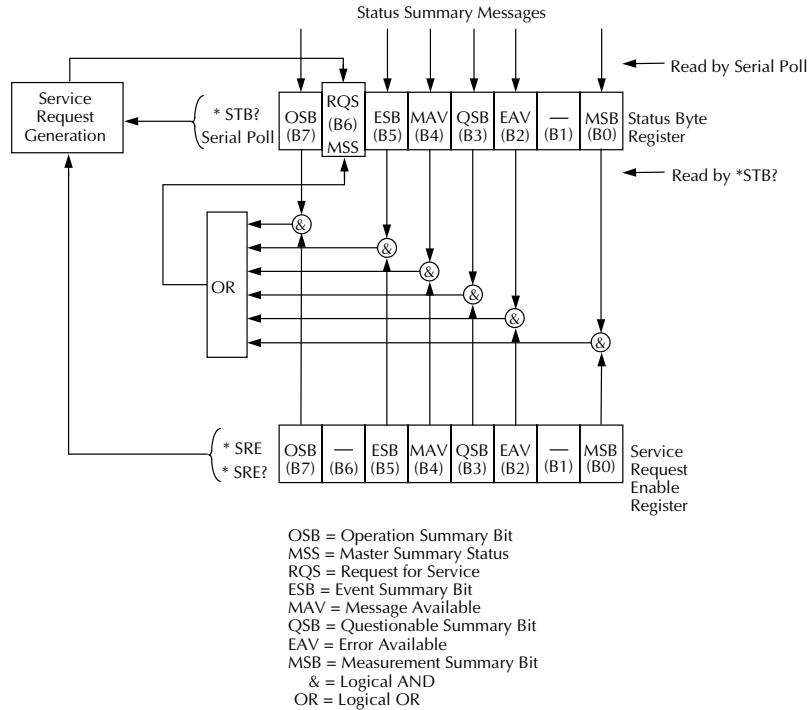

### Status Byte Register

The summary messages from the status registers and queues are used to set or clear the appropriate bits (B0, B2, B3, B4, B5, and B7) of the Status Byte Register. These bits do not latch, and their states (0 or 1) are dependent on the summary messages (0 or 1). For example, if the Standard Event Status Register is read, its register will clear. As a result, its summary message will reset to 0, which will clear the ESB bit in the Status Byte Register.

Bit B6 in the Status Byte Register is either:

- The Master Summary Status (MSS) bit, sent in response to the \*STB? command, indicates the status of any set bits with corresponding enable bits set.
- The Request for Service (RQS) bit, sent in response to a serial poll, indicates which device was requesting service by pulling on the SRQ line.

For a description of the other bits in the Status Byte Register, see “Common commands, \*STB?.”

The IEEE-488.2 standard uses the \*STB? common query command to read the Status Byte Register.

When reading the Status Byte Register using the \*STB? command, bit B6 is called the MSS bit. None of the bits in the Status Byte Register are cleared when using the \*STB? command to read it.

The IEEE-488.1 standard has a serial poll sequence that also reads the Status Byte Register and is better for detecting a service request (SRQ). When using the serial poll, bit B6 is called the RQS bit. Serial polling causes bit B6 (RQS) to reset. Serial polling is discussed in more detail in “Serial poll and SRQ.”

Either of the following operations clear all bits of the Status Byte Register:

- Cycling power.
- Sending the \*CLS common command.

*NOTE The MAV bit may or may not be cleared.*

## Service Request Enable Register

This register is user programmed and serves as a mask for the Status Summary Message bits (B0, B2, B3, B4, B5, and B7) of the Status Byte Register. When masked, a set summary bit in the Status Byte Register cannot set bit B6 (MSS/RQS) of the Status Byte Register. Conversely, when unmasked, a set summary bit in the Status Byte Register sets bit B6.

A Status Summary Message bit in the Status Byte Register is masked when the corresponding bit in the Service Request Enable Register is cleared (0). When the masked summary bit in the Status Byte Register sets, it is ANDed with the corresponding cleared bit in the Service Request Enable Register. The logic “1” output of the AND gate is applied to the input of the OR gate and, therefore, sets the MSS/RQS bit in the Status Byte Register.

The individual bits of the Service Request Enable Register can be set or cleared by using the \*SRE <NRf> common command.

To read the Service Request Enable Register, use the \*SRE? query command. The Service Request Enable Register clears when power is cycled or a parameter (n) value of zero is sent with the \*SRE command (\*SRE 0).

## Serial poll and SRQ

Any enabled event summary bit that goes from 0 to 1 will set RQS and generate a service request (SRQ). In your test program, you can periodically read the Status Byte Register to check if a service request (SRQ) has occurred and what caused it. If an SRQ occurs, the program can, for example, branch to an appropriate subroutine that will service the request. Typically, service requests (SRQs) are managed by the serial poll sequence of the Model 2304A. If an SRQ does not occur, bit B6 (RQS) of the Status Byte Register will remain cleared, and the program will proceed normally after the serial poll is performed. If an SRQ does occur, bit B6 of the Status Byte Register will set, and the program can branch to a service subroutine when the SRQ is detected by the serial poll.

The serial poll automatically resets RQS of the Status Byte Register. This allows subsequent serial polls to monitor bit B6 for an SRQ occurrence generated by other event types. After a serial poll, the same event can cause another SRQ, even if the event register that caused the first SRQ has not been cleared.

A serial poll clears RQS but does not clear MSS. The MSS bit stays set until all Status Byte event summary bits are cleared.

The following QuickBASIC 4.5 program (using the KPC-488.2 interface and the CECHP driver) demonstrates how serial poll can be used to detect an SRQ:

```
CLS
OPEN "ieee" FOR OUTPUT AS #1
OPEN "ieee" FOR INPUT AS #2
PRINT #1, "output 16; *cls"           ' Clear Status Byte Register
PRINT #1, "output 16; *ese 32"      ' Unmask command errors
PRINT #1, "output 16; *sre 32"      ' Unmask event summary message
PRINT #1, "output 16; *ese"         ' Error - missing parameter
SLEEP 1
PRINT #1, "SPOLL 16"                ' Serial poll 2304A
INPUT #2, S                          ' Read Status Byte Register
S=S OR 191                            ' OR register with a mask
IF S= 255 THEN
    OSUB srq                          ' Go to subroutine to acknowledge
                                      ' SRQ
END IF
PRINT
END
srq:
PRINT "SRQ Has Occurred--RQS (bit B6) is set (1)"
RETURN
```

# Programming syntax

The information in the following paragraphs covers syntax for both common commands and SCPI commands. For information not covered here, see the IEEE-488.2 and SCPI standards.

## Command words

Program messages are made up of one or more command words and parameters.

## Commands and command parameters

Common commands and SCPI commands may or may not use a parameter. The following are some examples:

*SAV <NRf>	Parameter (NRf) required
*RST	No parameter used
:DISPlay:TEXT:STATe <b>	Parameter <b> required
:STATus:PRESet	No parameter used.

Put at least one space between the command word and the parameter.

**Brackets [ ]**— Some command words are enclosed in brackets ([ ]). These brackets are used to denote an optional command word that does not need to be included in the program message. For example:

```
:FORMat[:DATA]?
```

These brackets indicate that :DATA is implied (optional) and does not have to be used. Thus, the above command can be sent as :FORMat? or :FORMat:DATA?.

Notice that the optional command is used without the brackets. When using optional command words in your program, do not include the brackets.

**Parameter types** — The following are some of the more common parameter types:

- <b> Boolean — Used to enable or disable an instrument operation. 0 or OFF disables the operation, and 1 or ON enables the operation. Example:  
:DISPlay:TEXT:STATe ON Enable text messages mode of display.
- <name> Name parameter — Select a parameter name from a listed group. Example:  
<name> = LIMit  
= TRIP  
:CURRent:LIMit:TYPE TRIP Turn output off when current limit is reached.

- **<NRf>** Numeric representation format — This parameter is a number that can be expressed as an integer (e.g., 8), a real number (e.g., 23.6), or an exponent (2.3E6). Example:  

```
SENSe:AVERAge 5           Set average current value to 5
```
- **<n>** Numeric value — A numeric value parameter can consist of an NRf number or one of the following name parameters: DEFault, MINimum, MAXimum. When the DEFault parameter is used, the instrument is programmed to the \*RST default value. When the MINimum parameter is used, the instrument is programmed to the lowest allowable value. When the MAXimum parameter is used, the instrument is programmed to the largest allowable value. Examples:  

```
:SENSe:CURRent:RANGe 0.001    Selects 5mA range
:SENSe:CURRent:RANGe DEFault   Selects 5A range
:SENSe:CURRent:RANGe MINimum   Selects 5mA range
:SENSe:CURRent:RANGe MAXimum   Selects 5A range
```
- **<numlist>** Numlist — Specify one or more numbers for a list. Example:  

```
:STATus:QUEue:ENABle (-110:-222) Enable errors -110 through -222
```

**Angle Brackets < >** — Angle brackets (< >) are used to denote a parameter type. Do not include the brackets in the program message. For example:

```
:OUTPut <b>
```

The <b> indicates that a Boolean-type parameter is required. Therefore, to turn on the output, the command with the ON or 1 parameter must be sent as follows.

```
:OUTPut ON
:OUTPut 1
```

## Query commands

This type of command requests (queries) the presently programmed status. It is identified by the question mark (?) at the end of the fundamental form of the command. Most commands have a query form. Example:

```
:SENSe:CURRent:RANGe? Queries the present current range
```

Most commands that require a numeric parameter (<n>) can also use the DEFault, MINimum, and MAXimum parameters for the query form. These query forms are used to determine the \*RST default value and the upper and lower limits for the fundamental command. Examples:

```
:SENSe:CURRent:RANGe? DEFault    Queries the *RST default value
:SENSe:CURRent:RANGe? MINimum    Queries the lowest allowable value
:SENSe:CURRent:RANGe? MAXimum    Queries the largest allowable value
```

## Case sensitivity

Common commands and SCPI commands are not case sensitive. You can use upper or lower case and any case combination. Examples:

```
*RST           = *rst
:DATA?        = :data?
:STATus:PRESet = :status:preset
```

## Long-form and short-form versions

A SCPI command word can be sent in its long-form or short-form version. The command subsystem tables in Section 4 provide the long-form version. However, the short-form version is indicated by upper case characters. Examples:

```
:STATus:PRESet      long-form
:STAT:PRES          short-form
:STATus:PRES        long-form and short-form combination
```

Note that each command word must be in either long-form or short-form. For example, :STATu:PRESe is illegal and will generate an error. The command will not be executed.

## Short-form rules

Use the following rules to determine the short-form version of any SCPI command or parameter:

- If the length of the word is four letters or less, no short form version exists. Example:  
:auto = :auto

These rules apply to words that exceed four letters:

- If the fourth letter of the word is a vowel, delete it and all the letters after it. Example:  
:dvmeter = :dvm
- If the fourth letter of the command word is a consonant, retain it but drop all the letters after it. Example:  
:format = :form
- If the command contains a question mark (; query) or a non-optional number included in the command word, you must include it in the short-form version. Example:  
:function? = :func?
- Command words or characters that are enclosed in brackets ([ ]) are optional and need not be included in the program message.

## Program messages

A program message is made up of one or more command words sent by the computer to the instrument. Each common command is a three letter acronym preceded by an asterisk (\*). SCPI commands are categorized in the :STATus subsystem and are used to help explain how command words are structured to formulate program messages.

:STATus	Path (Root)
:OPERation	Path
:ENABle <NRf>	Command and parameter
:ENABle?	Query command
:PRESet	Command

### Single command messages

The previous command structure has three levels. The first level is made up of the root command (:STATus) and serves as a path. The second level is made up of another path (:OPERation) and a command (:PRESet). The third path is made up of one command for the :OPERation path. The three commands in this structure can be executed by sending three separate program messages as follows:

```
:stat:oper:enab <NRf>
:stat:oper:enab?
:stat:pres
```

In each of the above program messages, the path pointer starts at the root command (:stat) and moves down the command levels until the command is executed.

### Multiple command messages

You can send multiple command messages in the same program message as long as they are separated by semicolons (;). Here is an example showing two commands in one program message:

```
:stat:pres; :stat:oper:enab <NRf>
```

When this command is sent, the first command word is recognized as the root command (:stat). When the next colon is detected, the path pointer moves down to the next command level and executes the command. When the path pointer sees the colon after the semicolon (;), it resets back to the root level and starts over.

Commands that are on the same command level can be executed without having to retype the entire command path. Example:

```
:stat:oper:enab <NRf>; enab?
```

After the first command (:enab) is executed, the path pointer is at the third command level in the structure. Since :enab? is also on the third level, it can be typed in without repeating the entire path name. Notice that the leading colon for :enab? is not included in the program message. If a colon were included, the path pointer would reset to the root level and expect a root command. Since :enab? is not a root command, an error would occur.

## Command path rules

- Each new program message must begin with the root command, unless it is optional (e.g., [:SENSe]). If the root is optional, treat a command word on the next level as the root.
- The colon (:) at the beginning of a program message is optional and need not be used. Example:  

```
    :stat:pres = stat:pres
```
- When the path pointer detects a colon (:), it moves down to the next command level. An exception is when the path pointer detects a semicolon (;), which is used to separate commands within the program message (see next rule).
- When the path pointer detects a colon (:) that immediately follows a semicolon (;), it resets back to the root level.
- The path pointer can only move down; it cannot be moved up a level. Executing a command at a higher level requires that you start over at the root command.

## Using common and SCPI commands in the same message

Both common commands and SCPI commands can be used in the same message as long as they are separated by semicolons (;). A common command can be executed at any command level and will not affect the path pointer. Example:

```
:stat:oper:enab <NRf>; *ESE <NRf>
```

## Program message terminator (PMT)

Each program message must be terminated with an LF (line feed), EOI (end or identify), or an LF+EOI. The bus will hang if your computer does not provide this termination. The following example shows how a multiple command program message must be terminated:

```
:outp on <PMT>
```

## Command execution rules

- Commands execute in the order that they are presented in the program message.
- An invalid command generates an error and is not executed.
- Valid commands that precede an invalid command in a multiple command program message are executed.
- Valid commands that follow an invalid command in a multiple command program message are ignored.



## Response messages

A response message is the message sent by the instrument to the computer in response to a query command program message.

### Sending a response message

After sending a query command, the response message is placed in the Output Queue. When the Model 2304A is then addressed to talk, the response message is sent from the Output Queue to the computer.

### Multiple response messages

If you send more than one query command in the same program message (see “Multiple command messages”), the multiple response messages for all the queries are sent to the computer when the Model 2304A is addressed to talk. The responses are sent in the order the query commands were sent and are separated by semicolons (;). Items within the same query are separated by commas (,). The following example shows the response message for a program message that contains four single item query commands:

```
0; 1; 1; 0
```

### Response message terminator (RMT)

Each response is terminated with an LF (line feed) and EOI (end or identify). The following example shows how a multiple response message is terminated:

```
0; 1; 1; 0; <RMT>
```

## Message exchange protocol

Two rules summarize the message exchange protocol:

Rule 1: You must always tell the Model 2304A what to send to the computer.

The following two steps must always be performed to send information from the instrument to the computer:

1. Send the appropriate query command(s) in a program message.
2. Address the Model 2304A to talk.

Rule 2: The complete response message must be received by the computer before another program message can be sent to the Model 2304A.

# Common commands

Common commands (summarized in Table 3-3) are device commands that are common to all devices on the bus. These commands are designated and defined by the IEEE-488.2 standard.

**Table 3-3**  
*Common commands*

Mnemonic	Name	Description
*CLS	Clear status	Clears all event registers and Error Queue.
*ESE <NRf>	Event enable command	Programs the Standard Event Enable Register.
*ESE?	Event enable query	Reads the Standard Event Enable Register.
*ESR?	Event status register query	Reads the Standard Event Enable Register and clears it.
*IDN?	Identification query	Returns the manufacturer, model number, serial number, and firmware revision levels of the unit.
*OPC	Operation complete command	Sets OPC bit after all pending commands are done.
*OPC?	Operation complete query	Puts an ASCII "1" in the output queue after all pending operations are done.
*RCL <NRf>	Recall setup command	Returns the instrument to the setup stored at the specified memory location.
*RST	Reset command	Returns the Model 2304A to the *RST default conditions.
*SAV <NRf>	Save setup command	Saves the present setup at the specified memory location.
*SRE <NRf>	Service request enable command	Programs the Service Request Enable Register.
*SRE?	Service request enable query	Reads the Service Request Enable Register.
*STB?	Status byte query	Reads the Status Byte Register.
*TRG	Trigger command	Trigger and display a single reading.
*TST?	Self-test query	Performs a ROM checksum test and returns the result.
*WAI	Wait-to-continue command	Wait until all previous commands are executed.

## \*CLS — Clear Status

### Clear status registers and error queue

#### Description

Use the \*CLS command to clear (reset to 0) the bits of the following registers in the Model 2304A:

- Standard Event Register
- Operation Event Register
- Error Queue
- Measurement Event Register
- Questionable Event Register

This command also forces the instrument into the operation complete command idle state and operation complete query idle state.

<b>*ESE &lt;NRf&gt; — Event Enable</b>		<b>Program the standard event enable register</b>
<b>*ESE? — Event Enable Query</b>		<b>Read the standard event register</b>
<b>Parameters</b>	<NRf> =	
	0	Clear register
	1	Set OPC (B0)
	4	Set QYE (B2)
	8	Set DDE (B3)
	16	Set EXE (B4)
	32	Set CME (B5)
	64	Set URQ (B6)
	128	Set PON (B7)
	255	Set all bits

**Description** Use the \*ESE command to program the Standard Event Enable Register. This command is sent with the decimal equivalent of the binary value that determines the desired state (0 or 1) of the bits in the register. This register is cleared on power-up.

This register is used as a mask for the Standard Event Register. When a standard event is masked, the occurrence of that event will not set the Event Summary Bit (ESB) in the Status Byte Register. Conversely, when a standard event is unmasked (enabled), the occurrence of that event sets the ESB bit. For information on the Standard Event Register and descriptions of the standard event bits see the \*ESR? command.

A cleared bit (0) in the enabled register prevents (masks) the ESB bit in the Status Byte Register from setting when the corresponding standard event occurs. A set bit (1) in the enable register allows (enables) the ESB bit to set when the corresponding standard event occurs.

The Standard Event Enable Register is shown in Figure 3-8 and includes the decimal weight of each bit. The sum of the decimal weights of the bits that you wish to be set is the parameter value that is sent with the \*ESE command. For example, to set the CME and QYE bits of the Standard Event Enable Register, send the following command:

\*ESE 36

where:	CME (bit B5)	=	32
	QYE (bit B2)	=	<u>4</u>
	<NRf>	=	36

If a command error (CME) occurs, bit B5 of the Standard Event Status Register sets. If a query error (QYE) occurs, bit B2 of the Standard Event Status Register sets. Since both of these events are unmasked (enabled) the occurrence of any one of them causes the ESB bit in the Status Byte Register to set.

Read the Standard Event Status Register using the \*ESE? query command.

**Figure 3-8**  
Standard event  
enable register

Bit Position	B7	B6	B5	B4	B3	B2	B1	B0
Event	PON	URQ	CME	EXE	DDE	QYE	—	OPC
Decimal Weighting	128 (2 <sup>7</sup> )	64 (2 <sup>6</sup> )	32 (2 <sup>5</sup> )	16 (2 <sup>4</sup> )	8 (2 <sup>3</sup> )	4 (2 <sup>2</sup> )	—	1 (2 <sup>0</sup> )
Value	0/1	0/1	0/1	0/1	0/1	0/1	—	0/1

Note : Bits B8 through B15 are not shown since they are not used.

Value : 1 = Enable Standard Event  
0 = Disable (Mask) Standard Event

Events : PON = Power On  
URQ = User Request  
CME = Command Error  
EXE = Execution Error  
DDE = Device-dependent Error  
QYE = Query Error  
OPC = Operation Complete

**\*ESR? — Event Status Register Query** Read the standard event status register and clear it

**Description** Use this command to acquire the value (in decimal) of the Standard Event Register (see Figure 3-9). The binary equivalent of the returned decimal value determines which bits in the register are set. The register is cleared on power-up or when \*CLS is sent.

A set bit in this register indicates that a particular event has occurred. For example, for an acquired decimal value of 48, the binary equivalent is 00110000. From this binary value, bits B4 and B5 of the Standard Event Status Register are set. These bits indicate that a device-dependent error and command error have occurred.

**Figure 3-9**  
Standard event  
status register

Bit Position	B7	B6	B5	B4	B3	B2	B1	B0
Event	PON	URQ	CME	EXE	DDE	QYE	—	OPC
Decimal Weighting	128 (2 <sup>7</sup> )	64 (2 <sup>6</sup> )	32 (2 <sup>5</sup> )	16 (2 <sup>4</sup> )	8 (2 <sup>3</sup> )	4 (2 <sup>2</sup> )	—	1 (2 <sup>0</sup> )
Value	0/1	0/1	0/1	0/1	0/1	0/1	—	0/1

Note : Bits B8 through B15 are not shown since they are not used.

Value : 1 = Event Bit Set  
0 = Event Bit Cleared

Events : PON = Power On  
URQ = User Request  
CME = Command Error  
EXE = Execution Error  
DDE = Device-dependent Error  
QYE = Query Error  
OPC = Operation Complete

The bits of the Standard Event Status Register are described as follows:

- **Bit B0, Operation Complete** — A set bit indicates that all pending selected device operations are completed and the Model 2304A is ready to accept new commands. This bit only sets in response to the \*OPC command. It is not affected by the \*OPC? query command.
- **Bit B1** — Not used.
- **Bit B2, Query Error (QYE)** — A set bit indicates that you attempted to read data from an empty Output Queue.
- **Bit B3, Device-Dependent Error (DDE)** — A set bit indicates that an instrument operation did not execute properly due to some internal condition.
- **Bit B4, Execution Error (EXE)** — A set bit indicates that the Model 2304A detected an error while trying to execute a command.
- **Bit B5, Command Error (CME)** — A set bit indicates that a command error has occurred. Command errors include:
  - IEEE-488.2 syntax error — Model 2304A received a message that does not follow the defined syntax of the IEEE-488.2 standard.
  - Semantic error — Model 2304A received a command that was misspelled, or received an optional IEEE-488.2 command that is not implemented.
  - The instrument received a Group Execute Trigger (GET) inside a program message.
- **Bit B6, User Request (URQ)** — A set bit indicates that the LOCAL key on the Model 2304A front panel was pressed.
- **Bit B7, Power ON (PON)** — A set bit indicates that the Model 2304A has been turned off and turned back on since the last time this register has been read.

**\*IDN? — Identification Query**

**Read the identification code**

**Description** The identification code includes the manufacturer, model number, serial number, and firmware revision levels and is sent in the following format:  
 KEITHLEY INSTRUMENTS INC., MODEL 2304A, xxxxxxxx, yyyyyy/  
 zzzzzz  
 where: xxxxxxxx is the serial number  
 yyyyyy/zzzzz is the firmware revision levels of the digital board ROM and display board ROM.

**\*OPC — Operation Complete**

**Set the OPC bit in the standard event status register after all pending commands are complete**

**Description** When this command is sent, the OPC bit in the standard event status register will set after all pending commands are complete.  
 Typically, this command is sent after a reading or reading array is requested. While the instrument is acquiring readings, all commands (except DCL, SDC, IFC, \*TRG, and GET) that are sent are not executed.  
 After all readings are acquired, the instrument returns to the idle state at which time all pending commands (including the \*OPC command) are executed. After the last pending command is executed, the OPC bit will set.

*NOTE Send an \*OPC command, separated by a semicolon, on the same line as a command or query. If sent on separate lines, an error message is displayed.*

**\*OPC? — Operation Complete Query**

**Place a “1” in the output queue after all pending operations are completed**

**Description** When this command is sent, an ASCII “1” is placed in the output queue after all pending operations are completed.  
 Typically, this command is sent after a reading or reading array is requested. While the instrument is acquiring readings, all commands (except DCL, SDC, IFC, \*TRG, and GET) that are sent are not executed.  
 After all readings are acquired, the instrument returns to the idle state at which time all pending commands (including the \*OPC command) are executed. After the last pending command is executed, “1” is placed in the output queue.

*NOTE Send an \*OPC? query, separated by a semicolon, on the same line as another query. If sent on separate lines, an error message is displayed. The \*OPC? query can be sent on the same line or a separate line as a command (not a query).*

**\*RCL — Recall****Return to setup stored in memory**

<b>Parameters</b>	<NRF> = 0	Return to saved setup configuration at memory location 0
	1	Return to saved setup configuration at memory location 1
	2	Return to saved setup configuration at memory location 2
	3	Return to saved setup configuration at memory location 3
	4	Return to saved setup configuration at memory location 4

**Description** Use this command to return the Model 2304A to the configuration stored at the specified memory location (0 to 4). The \*SAV command is used to store the setup configuration in memory.

*NOTE The output is always saved and recalled in an OFF state.*

**\*RST — Reset****Return Model 2304A to \*RST defaults**

**Description** When the \*RST command is sent, the Model 2304A performs the following operations:

- Returns the Model 2304A to the \*RST default conditions (see SCPI tables).
- Cancels all pending commands.
- Cancels response to any previously received \*OPC and \*OPC? commands.

**\*SAV — Save****Save present setup in memory**

<b>Parameters</b>	<NRF> = 0	Save setup at memory location 0
	1	Save setup at memory location 1
	2	Save setup at memory location 2
	3	Save setup at memory location 3
	4	Save setup at memory location 4

**Description** Use the \*SAV command to save the present instrument setup configuration in memory for later recall. Up to five setup configurations can be saved. Any control affected by \*RST can be saved by the \*SAV command. The \*RCL command is used to restore the instrument to the saved setup configuration.

*NOTE The output is always saved and recalled in an OFF state.*

**\*SRE <NRf> — Service Request Enable**      Program register

**\*SRE? — Service Request Enable Query**      Read register

Parameters	<NRf> =	0	Clears enable register
		1	Set MSB bit (Bit 0)
		4	Set EAV bit (Bit 2)
		8	Set QSB bit (Bit 3)
		16	Set MAV bit (Bit 4)
		32	Set ESB (Bit 5)
		128	Set OSB (Bit 7)
		255	Set all bits

**Description**      Use the \*SRE command to program the Service Request Enable Register. Send this command with the decimal equivalent of the binary value that determines the desired state (0 or 1) of each bit in the register. This register is cleared on power-up.

This enable register is used along with the Status Byte Register to generate service requests (SRQ). With a bit in the Service Request Enable Register set, an SRQ occurs when the corresponding bit in the Status Byte Register is set by an appropriate event. For more information on register structure, see the information presented earlier in this section.

The Service Request Enable Register is shown in Figure 3-10. Notice that the decimal weight of each bit is included in the illustration. The sum of the decimal weights of the bits that you wish to set is the value that is sent with the \*SRE command. For example, to set the ESB and MAV bits of the Service Request Enable Register, send the following command:

\*SRE 48

where: ESB (bit B5) = 32  
           MAV (bit B4) = 16  
           <NRf>       = 48

The contents of the Service Request Enable Register can be read using the \*SRE? query command.



**Figure 3-10**  
Service request  
enable register

Bit Position	B7	B6	B5	B4	B3	B2	B1	B0
Event	OSB	—	ESB	MAV	QSB	EAV	—	MSB
Decimal Weighting	128 (2 <sup>7</sup> )	—	32 (2 <sup>5</sup> )	16 (2 <sup>4</sup> )	8 (2 <sup>3</sup> )	4 (2 <sup>2</sup> )	—	1 (2 <sup>0</sup> )
Value	0/1	—	0/1	0/1	0/1	0/1	—	0/1

Value : 1 = Enable Service Request  
Event  
0 = Disable (Mask) Service  
Request Event

Events : OSB = Operation Summary Bit  
ESB = Event Summary Bit  
MAV = Message Available  
QSB = Questionable Summary Bit  
EAV = Error Available  
MSB = Measurement Summary Bit

### \*STB? — Status Byte Query

### Read status byte register

#### Description

Use the \*STB? query command to acquire the value (in decimal) of the Status Byte Register. The Status Byte Register is shown in Figure 3-11. The binary equivalent of the decimal value determines which bits in the register are set.

All bits, except Bit B6, in this register are set by other event registers and queues. Bit 6 sets when one or more enabled conditions occur.

The \*STB? query command does not clear the status byte register. This register can only be cleared by clearing the related registers and queues.

For example, for an acquired decimal value of 48, the binary equivalent is 00110000. This binary value indicates that bits 4 and 5 of the Status Byte Register are set.

The bits of the Status Byte Register are described as follows:

- **Bit 0, Measurement Status (MSB)** — A set bit indicates that a measurement event has occurred. The event can be identified by reading the Measurement Event Status Register using the :STATus:MEASurement? command.
- **Bit 1** — Not used.
- **Bit 2, Error Available (EAV)** — A set bit indicates that an error or status message is present in the Error Queue. The message can be read using one of the following SCPI commands:
  - :SYSTem:ERRor?
  - :STATus:QUEue?
- **Bit 3, Questionable Summary Bit (QSB)** — A set bit indicates that a calibration error has occurred.

- **Bit 4, Message Available (MAV)** — A set bit indicates that a message is present in the Output Queue. The message is sent to the computer when the Model 2304A is addressed to talk.
- **Bit 5, Event Summary Bit (ESB)** — A set bit indicates that an enabled standard event has occurred. The event can be identified by reading the Standard Event Status Register using the \*ESE? query command.
- **Bit 6, Master Summary Status (MSS)/Request Service (RQS)** — A set bit indicates that one or more enabled Status Byte conditions have occurred. Read the MSS bit by using the STB? query command, or perform a serial poll to detect the occurrence of a service request (RQS bit set).
- **Bit 7, Operation Summary (OSB)** — A set bit indicates that an enabled operation event has occurred. The event can be identified by reading the Operation Event Status Register using the :STATus:OPERation? query command.

**Figure 3-11**  
Status byte register

Bit Position	B7	B6	B5	B4	B3	B2	B1	B0
Event	OSB	MSS, RQS	ESB	MAV	QSB	EAV	—	MSB
Decimal Weighting	128 (2 <sup>7</sup> )	64 (2 <sup>6</sup> )	32 (2 <sup>5</sup> )	16 (2 <sup>4</sup> )	8 (2 <sup>3</sup> )	4 (2 <sup>2</sup> )	—	1 (2 <sup>0</sup> )
Value	0/1	0/1	0/1	0/1	0/1	0/1	—	0/1

Value : 1 = Event Bit Set  
 0 = Event Bit Cleared

Events : OSB = Operation Summary Bit  
 MSS = Master Summary Status  
 RQS = Request Service  
 ESB = Event Summary Bit  
 MAV = Message Available  
 QSB = Questionable Summary Bit  
 EAV = Error Available  
 MSB = Measurement Summary Bit

**\*TRG — Trigger****Send bus trigger to 2304A**

**Description** Use the \*TRG command to trigger and display a single reading for the function presently selected. If the average count is  $>1$ , then the single reading will be the average reading. It has the same effect as a group execute trigger (GET).

**\*TST? — Self-Test Query****Run self-test and read result**

**Description** Use this query command to perform a checksum test on ROM. The command places the coded result (0 or 1) in the Output Queue. When the Model 2304A is addressed to talk, the coded result is sent from the Output Queue to the computer.

A returned value of zero (0) indicates that the test passed, and a value of one (1) indicates that the test has failed.

**\*WAI — Wait-to-Continue****Wait until previous commands are completed**

**Description** Effectively, the \*WAI command is a No Op (no operation) for the Model 2304A and therefore, does not need to be used.

There are two types of device commands:

- **Sequential commands** — A command whose operations are allowed to finish before the next command is executed.
- **Overlapped commands** — A command that allows the execution of subsequent commands while device operations of the Overlapped command are still in progress.

The \*WAI command is used to suspend the execution of subsequent commands until the device operations of all previous Overlapped commands are finished. The \*WAI command is not needed for Sequential commands.

# SCPI Command Reference

---

## Introduction

This section contains reference information on programming the Model 2304A with the SCPI commands. It is organized as follows:

- **SCPI signal oriented measurement commands** — Covers the signal oriented measurement commands. These commands are used to acquire measurement readings.
- **SCPI command subsystems reference tables** — Includes a summary table for each SCPI subsystem.
- **SCPI command subsystems** — Provides additional information on each SCPI subsystem command.

## Signal oriented measurement commands

The signal oriented measurement commands are used to acquire readings. You can use these high-level instructions to control the measurement process. These commands are summarized in Table 4-1.

*Table 4-1*  
*Signal oriented measurement command summary*

Command	Description
:FETCh?	Returns the last reading.
:FETCh:ARRay?	Returns the last array of readings.
:READ?	Triggers a new reading and returns it.
:READ:ARRay?	Triggers a new array of readings and returns them.
:MEASure[:<function>]?	Perform a READ? on the specified function.
:MEASure:ARRay[:<function>]?	Perform a READ:ARRay? on the specified function.

NOTE: For all array queries, make sure the computer's buffer is large enough to accommodate all array readings.

### **:FETCh?**

**Return last reading**

### **:FETCh:ARRay?**

**Return last array of readings**

### **Description**

The :FETCh? command is used to return the last averaged reading, and the :FETCh:ARRay? command is used to return the last array of readings. After sending either one of these commands and addressing the Model 2304A to talk, the averaged reading or reading array is sent to the computer. These commands do not affect the instrument setup.

These commands do not trigger measurements. They return the last available averaged reading or reading array. Note that they can repeatedly return the same reading or reading array. Until there is a new reading(s), these commands continue to return the old reading(s).

The number of readings to average or put in an array is set using the :SENSE:AVERAge (for voltage, current and DVM readings) or :SENSE:PCURrent:AVERAge (for pulse-current readings) command. See “Sense subsystem” for details.

*NOTE* There are no AVERAge commands for long integration measurements. The array size for long integration measurements is fixed at one. Therefore, both FETCh? and FETCh:ARRAy? will return the last reading.

<b>:READ?</b>	<b>Trigger and return reading</b>
<b>:READ:ARRAy?</b>	<b>Trigger and return array of readings</b>

**Description** The :READ? command is used to trigger and return a single averaged reading, and the :READ:ARRAy? command is used to trigger and return an array of readings. The averaged reading or reading array is sent to the computer and displayed when the Model 2304A is addressed to talk.

The number of readings to average or put in an array is set using the :SENSE:AVERAge (for voltage, current and DVM readings) or :SENSE:PCURrent:AVERAge (for pulse-current readings) command. See “Sense subsystem” for details.

*NOTE* There are no AVERAge commands for long integration measurements. The array size for long integration measurements is fixed at one. Therefore, both READ? and READ:ARRAy? will trigger and return a single reading.

<b>:MEASure[:&lt;function&gt;]?</b>	<b>Execute :READ? on specified function</b>
<b>:MEASure:ARRAy[:&lt;function&gt;]?</b>	<b>Execute :READ:ARRAy? on specified function</b>

<b>Parameters</b>	<function> = CURRent[:DC]	Measure current
	VOLTage[:DC]	Measure voltage
	PCURrent	Measure pulse-current
	DVMeter	Measure DVM input
	LINTegration	Perform long integration current measurements.

**Description** When the MEASure? command is sent, the specified function is selected and then the READ? is executed. When the MEASure:ARRAy? command is sent, the specified function is selected and the READ:ARRAy? command is executed. See READ? and READ:ARRAy? for details.

If a function is not specified, the measurements(s) will be performed on the function presently selected.

*NOTE* There are no AVERAge commands for long integration measurements. The array size for long integration measurements is fixed at one. Therefore, MEASure:LINTegration and MEASure:ARRAy:LINTegration? are basically the same.

# SCPI command subsystems reference tables

Tables 4-2 to 4-8 summarize the commands for each SCPI subsystem. The following list includes the SCPI subsystem commands and the table number where each command is summarized.

- Table 4-2 DISPlay command summary
- Table 4-3 FORMat command summary
- Table 4-4 OUTPut command summary
- Table 4-5 SENSE command summary
- Table 4-6 SOURce command summary
- Table 4-7 STATus command summary
- Table 4-8 SYSTem command summary

## General notes

- Brackets ([ ]) are used to denote optional character sets. These optional characters do not have to be included in the program message. Do not use brackets in the program message.
- Angle brackets (<>) are used to indicate parameter type. Do not use angle brackets in the program message.
- The Boolean parameter (<b>) is used to enable or disable an instrument operation. ON or 1 enables the operation, and 0 or OFF disables it.
- Upper case characters include the short-form version for each command word.
- Default Parameter — Listed parameters are the \*RST default. Parameter notes are located at the end of each table.
- SCPI — A checkmark (✓) indicates that the command and its parameters are SCPI confirmed. An unmarked command indicates that it is a SCPI command but does not conform to the SCPI standard set of commands. It is not a recognized command by the SCPI consortium. SCPI confirmed commands that use one or more non-SCPI parameters are explained by notes.

**Table 4-2**  
*DISPlay command summary*

Command	Description	Default parameter	SCPI
:DISPLay			
:ENABle <b>	Enable or disable front panel display.	(Note 1)	✓
:ENABle?	Query state of display.		✓
[:WINDow[1]]	Path to locate message display:		✓
:TEXT	Control user text message:	(Note 2)	✓
:DATA <a>	Define ASCII message “a” (up to 32 characters).		✓
:DATA?	Query text message.		✓
:STATe <b>	Enable or disable message mode.	(Note 3)	✓
:STATe?	Query state of message mode.		✓

Notes

1. \*RST has no effect on display circuitry. Cycling power enables (ON) the display circuit.
2. \*RST has no effect on a user-defined message. Cycling power cancels all user-defined messages.
3. \*RST has no effect on the state of the message mode. Cycling power disables (OFF) the message mode.

**Table 4-3**  
*FORMat command summary*

Command	Description	Default parameter	SCPI
:FORMat			
[:DATA] <type>, [<length>]	Specify data format (ASCIi, SREal, or DREal).	ASCIi	✓
[:DATA?]	Query data format.		✓
:BORDer <name>	Specify byte order (NORMal or SWAPped).	SWAPped	✓
:BORDer?	Query byte order.		✓

**Table 4-4**  
*OUTPut command summary*

Command	Description	Default parameter	SCPI
:OUTPut			✓
[:STATe] <b>	Turn output on or off.	OFF	✓
[:STATe]?	Query state of output.		✓
:RESPonse <name>	Select output response mode (NORMal or ENHanced).	NORMal	✓
:RESPonse?	Query output response mode.		✓
:RELay1 <name>	Close (ONE) or open (ZERO) control circuit for relay 1.	ZERO	
:RELay1?	Query state of relay circuit 1.		
:RELay2 <name>	Close (ONE) or open (ZERO) control circuit for relay 2.	ZERO	
:RELay2?	Query state of relay circuit 2.		



**Table 4-5**  
SENSe command summary

Command	Description	Default parameter	SCPI
:SENSe[1]			
:FUNCTION <name>	Select measurement function (“VOLTage,” “CURRent,” “PCURrent,” “DVMeter,” or “LINTegration”).	VOLT	
:FUNCTION?	Query measurement function.		
:NPLCycles <n>	Specify integration rate (in line cycles) for voltage, current, and DVM measurements (0.01 to 10).	1	✓
:NPLCycles?	Query integration rate.		✓
:AVERAge <NRf>	Specify the average count for voltage, current, and DVM measurements (1 to 10).	1	
AVERAge?	Query average count.		
:CURRent [:DC]	Path to configure the current measurement function:		✓
:RANGe	Current measurement range:		✓
[:UPPer] <n>	Measurement range — specify expected current (0 to 5 amps).	5.0	✓
[:UPPer]?	Query current measurement range.		✓
:AUTO <b>	Enable or disable auto range.	OFF	✓
:AUTO	Query state of auto range.		
:PCURrent	Path to configure the pulse-current measurement function:		
:AVERAge <NRf>	Specify the average count for pulse-current measurements (1 to 100).	1	
:AVERAge?	Query average count.		
:MODE <name>	Select pulse-current measurement mode (HIGH, LOW, or AVERAge).	HIGH	
:MODE?	Query pulse-current measurement mode.		
:TIME	Path to set pulse-current integration times:		
:AUTO	Model 2304A sets the integration times.		
:HIGH <NRf>	Specify integration time (in sec) for high pulse measurements (33.33E-06 to 0.8333).	3.333E-05	
:HIGH?	Query high integration time.		
:LOW <NRf>	Specify integration time (in sec) for low pulse measurements (33.33E-06 to 0.8333).	3.333E-05	
:LOW?	Query low integration time.		
:AVERAge <NRf>	Specify integration time (in sec) for average pulse measurements (33.33E-06 to 0.8333).	3.333E-05	
:AVERAge?	Query average integration time.		
:SYNChronize	Path for pulse detection triggering:		
[:STATe] <b>	Enable or disable trigger level and delay. ON-pulse current readings. OFF-digitize pulse.	ON	
[:STATe]?	Query state of trigger level and delay.		
:DELAy <NRf>	Specify trigger delay: 0 to 0.1 (sec).	0	
:DELAy?	Query trigger delay.		

**Table 4-5 (cont.)***SENSe command summary*

Command	Description	Default parameter	SCPI
:SENSe[1] :PCURrent :SYNChronize :TLEVel <NRf> :TLEVel? :LINTegration :TIME <NRf> :TIME? :AUTO :TLEVel <NRf> :TLEVel? :TEDGe <name> :TEDGe? :TimeOUT <NRf> :TimeOUT? :SEARCh <b> :SEARCh?	Query trigger level: 0 to 5 (amps). Query trigger level. Path to configure long integration measurements: Set integration time in seconds; X to 60 (where X is 0.850 for 60Hz or 0.840 for 50Hz). Query integration time. Model 2304A sets integration time. Specify trigger level; 0 to 5A. Query trigger level. Select trigger edge to initiate the measurement; RISING, FALLING, or NEITHER. Query trigger edge. Specify length of timeout; 1 to 63 (seconds). Query timeout. Enable or disable pulse search. Query state of pulse search.	0  1  0 RISING  16  ON	

**Table 4-6***SOURce command summary*

Command	Description	Default parameter	SCPI
[[:SOURce] :VOLTage [:LEVel] [:IMMEDIATE] [AMPLitude] <n> [AMPLitude]? :CURrent :LIMit [:VALue] <NRf> [:VALue]? :TYPE <name> :TYPE? :STATE?	Path to set output voltage:  Specify voltage amplitude (0 to 20 volts). Query voltage amplitude. Path to configure current: Path to configure current limit: Specify current limit value (0 to 5 amps). Query current limit value. Select current limit type (LIMit or TRIP). Query current limit type. Query state of current limit: 1 = in current limit (for LIMit type) or output tripped (for TRIP type), 0=not in LIMit/TRIP.	0  0.25 LIM	✓ ✓ ✓ ✓

**Table 4-7**  
*STATus command summary*

Command	Description	Default parameter	SCPI
:STATus		(Note 1)	✓
:MEASurement	Path to control the measurement event registers:		
[:EVENT]?	Read the event register.	(Note 2)	
:ENABle <NRf>	Program the enable register.	(Note 3)	
:ENABle?	Read the enable register.		
:CONDition?	Read the condition register.		
:OPERation	Path to control the operation status registers:		✓
[:EVENT]?	Read the event register.	(Note 2)	✓
:ENABle <NRf>	Program the enable register.	(Note 3)	✓
:ENABle?	Read the enable register.		✓
:CONDition?	Read the condition register.		✓
:QUESTionable	Path to control the questionable status registers:		✓
[:EVENT]?	Read the event register.	(Note 2)	✓
:ENABle <NRf>	Program the enable register.	(Note 3)	✓
:ENABle?	Read the enable register.		✓
:CONDition?	Read the condition register.		✓
:PRESet	Return status registers to default states.		✓
:QUEue	Path to access Error Queue.		✓
[:NEXT]?	Read the least recent error message.	(Note 4)	✓
:ENABle <list>	Specify error and status messages for queue.	(Note 5)	✓
:ENABle?	Read the enabled list of messages.		✓
:DISAble <list>	Specify messages not to be placed in queue.	(Note 5)	✓
:DISAble?	Read the disabled messages.		
:CLear	Clear all messages from Error Queue.		

## Notes:

- Commands in this subsystem are not affected by \*RST. The effects of cycling power, \*CLS, and :STATus:PRESet are explained by the following notes.
- Event Registers  
 Power-up and \*CLS — Clears all bits of the registers  
 :STATus:PRESet — No effect
- Enable Registers  
 Power-up and :STATus:PRESet — Clears all bits of the registers  
 \*CLS — No effect
- Error Queue  
 Power-up and \*CLS — Clears the Error Queue  
 :STATus:PRESet — No effect
- Enable/Disable Error Queue Messages  
 Power-up — Clears list of messages  
 \*CLS and :STATus:PRESet — No effect

**Table 4-8**  
*SYSTEM command summary*

Command	Description	Default parameter	SCPI
:SYSTem :VERSion? :ERRor? :CLEar :LFRequency? :POSetup <name> :POSetup?	Query SCPI version level. Read Error Queue. Clears Error Queue. Query power line frequency setting. Select power-on setup: RST or SAVX (where X = 0 to 4). Query power-on setup.		✓

## :DISPlay subsystem

The display subsystem controls the display of the Model 2304A and is summarized in Table 4-2.

### :ENABLE <b>

:DISPlay:ENABle <b> Control display circuitry

**Parameters**    <b> =            0 or OFF            Disable display circuitry  
    1 or ON            Enable display circuitry

**Query**            :ENABle?            Query state of display

**Description**    This command is used to enable and disable the front panel display circuitry. When disabled, the instrument operates at a higher speed. While disabled, the display is blank.

All front panel controls (except LOCAL) are disabled. Normal display operation can be resumed by using the :ENABLE command to enable the display or by putting the Model 2304A into local.



# FORMat subsystem

The commands for this subsystem are used to select the data format for transferring instrument readings over the bus. These commands are summarized in Table 4-3.

## **[[:DATA] <type>**

:FORMat[:DATA] <type>

Select data format

<b>Parameters</b>	<type> =	ASCii	ASCII format
		SREal	IEEE754 single precision format
		DREal	IEEE754 double precision format

**Query**            [:DATA]?            Query data format

**Description**    This command is used to select the data format for transferring readings over the bus. The reading(s) that is sent (voltage, current, pulse-current, DVM or long integration) depends on the presently selected function. See the :FUNction command (SENSE subsystem) and Signal Oriented Measurement Commands for more information.

***NOTE**    Regardless of which data format for output strings is selected, the SourceMeter will only respond to input commands using the ASCII format.*

### **ASCII format**

The ASCII data format is in a direct readable form for the operator. Most BASIC languages easily convert ASCII mantissa and exponent to other formats. However, some speed is compromised to accommodate the conversion. The following shows the ASCII format for a reading of 10.058 volts.

```
+1.00580000 E+01
```

### **IEEE754 formats**

SREal will select the binary IEEE754 single precision data format. Figure 4-1 shows the normal byte order format for each data element (voltage, current, etc.). Note that the data string for each reading conversion is preceded by a 2-byte header that is the binary equivalent of an ASCII # sign and 0. Not shown in Figure 4-1 is a byte for the terminator that is attached to the end of each data string.

**Figure 4-1**  
IEEE754 single  
precision data format

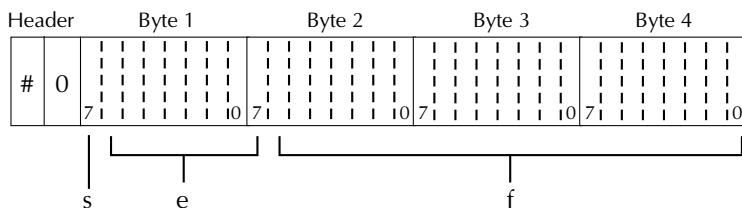

s = sign bit (0 = positive, 1 = negative)  
e = exponent bits (8)  
f = fraction bits (23)

Normal byte order shown. For swapped byte order,  
bytes sent in reverse order: Header, Byte 4, Byte 3,  
Byte 2, Byte 1.

The Header is only sent once for each measurement conversion.

DREal selects the binary IEEE754 double precision data format and is shown in Figure 4-2 (normal byte order shown). This format is similar to the single precision format except that it is 64 bits long.

During binary transfers, never un-talk the Model 2304A until after the data is read (input) to the computer. Also, to avoid erratic operation, the readings of the data string (and terminator) should be acquired in one piece. The header (#0) can be read separately before the rest of the string.

The number of bytes to be transferred can be calculated as follows:

$$\text{Bytes} = 2 + (\text{Rdgs} \times 4) + 1 = 43 \quad \text{for SREAL}$$

$$\text{Bytes} = 2 + (\text{Rdgs} \times 8) + 1 = 83 \quad \text{for DREAL}$$

where: 2 is the number of bytes for the header (#0).

Rdgs is the number of readings to be transferred.

4 or 8 is the number of bytes for each reading.

1 is the byte for the terminator.

For example, assume that the power supply is configured to trigger 10 voltage readings and send the 10 voltage measurements to the computer using the binary format.

$$\text{Bytes} = 2 + (10 \times 4) + 1 = 43 \quad \text{for SREAL}$$

$$\text{Bytes} = 2 + (10 \times 8) + 1 = 83 \quad \text{for DREAL}$$





**Comments**

Line 1 — Return to default configuration.

Line 2 — Set output voltage to 15V.

Line 3 — Set average count to 10.

Line 4 — Select binary data format.

Line 5 — Turn output on.

Line 6 — Trigger 10 readings.

Line 7 — Address Model 2304A to talk: 43 bytes (two for the #0 header, 40 for the 10 readings, and one for the terminator).

Line 8 — Read first two bytes (#0) of the binary string.

Line 9 — Read the rest of the binary string (40 data bytes and one terminator byte).

Line 10 — Un-talk the Model 2304A.

Lines 11 through 14 — Retrieve the ten 4-byte readings from the string and display them on the computer CRT.

**:BORDER <name>**

:FORMat:BORDER <name>

Specify binary byte order

<b>Parameters</b>	<name> =	NORMAL	Normal byte order for binary formats
		SWAPped	Reverse byte order for binary formats

<b>Query</b>	:BORDER?	Query byte order
--------------	----------	------------------

**Description** This command is used to control the byte order for the IEEE754 binary formats. For normal byte order, the data format for each element is sent as follows:

Byte 1	Byte 2	Byte 3	Byte 4	(Single precision)
Byte 1	Byte 2	•••	Byte 8	(Double precision)

For reverse byte order, the data format for each element is sent as follows:

Byte 4	Byte 3	Byte 2	Byte 1	(Single precision)
Byte 8	Byte 7	•••	Byte 1	(Double precision)

The “#,0” header is not affected by this command. The header is always sent at the beginning of the data string for each measurement conversion.

The ASCII data format can only be sent in the normal byte order. The SWAPped selection is ignored when the ASCII format is selected.

# OUTPut subsystem

This subsystem is used to control the output of the power supply. These commands are summarized in Table 4-4.

## **[[:STATe] <b>**

:OUTPut[:STATe] <b> Turn power supply output on or off

**Parameters** <b> = 0 or OFF Turn output off  
1 or ON Turn output on

**Query** :OUTPut? Query state of power supply output

**Description** This command is used to turn the power supply output on or off. Note that DVM measurements can be performed with the output off.

## **:RESPonse <name>**

:OUTPut:RESPonse <name> Select output response mode

**Parameters** <name> = NORMal Normal response mode  
ENHanced Enhanced response mode

**Query** :RESPonse? Query output response mode

**Description** This command is used to check or change output response mode. In the NORMal mode, the standard output characteristics are in effect. In general, the ENHanced mode is used to improve transient response to load changes. However, maximum output voltage in this mode is 15V. The output response mode cannot be changed when the output is on or the output voltage setting is set outside the maximum constraints.

See Section 2, “Enhanced output response” for more information.

## **:RELay1 <name>**

:OUTPut:RELay1 <name> Close or open relay control circuit 1

**Parameters** <name> = ONE Close relay control circuit 1  
ZERO Open relay control circuit 1

**Query** :RELay1? Query state of relay circuit 1

**Description** This command is used to control the circuit for relay 1. The ONE parameter closes the control circuit allowing the relay to energize. The ZERO parameter opens the control circuit allowing the relay to de-energize. See Section 2, “Relay control” for details on using external relays.

**:RELAy2 <name>**

:OUTPut:RELAy2 &lt;name&gt; Close or open relay control circuit 2

<b>Parameters</b>	<name> =	ONE	Close relay control circuit 2
		ZERO	Open relay control circuit 2

<b>Query</b>	:RELAy2?	Query state of relay circuit 2
--------------	----------	--------------------------------

**Description** This command is used to control the circuit for relay 2. The ONE parameter closes the control circuit allowing the relay to energize. The ZERO parameter opens the control circuit allowing the relay to de-energize. See Section 2, “Relay control” for details on using external relays.

## SENSE subsystem

**:FUNCTION <name>**

:SENSE[1]:FUNCTION &lt;name&gt; Select measurement function

<b>Parameters</b>	<name> =	“VOLTage”	Volts readback
		“CURRent”	Current readback
		“PCURrent”	Pulse-current readback
		“DVMeter”	Digital voltmeter measurements
		“LINTegration”	Long integration current measurements

<b>Query</b>	:FUNCTION?	Query measurement function
--------------	------------	----------------------------

**Description** This command is used to select the function that is to be measured and displayed. The “VOLTage,” “CURRent,” “PCURrent,” and “LINTegration” functions read back what is being output by the power supply. “VOLTage” and “CURRent” displays ACTUAL V AND I measurements, “PCURrent” displays PULSE CURRENT measurements, and “LINTegration” displays long integration current measurements. The pulse-current measurement type (high, low, or average) is selected using the MODE command.

With “DVMeter” selected, the instrument displays and measures voltage applied to the input of the digital voltmeter (DVM).

## Voltage, current, and DVM commands

### :NPLCycles <n>

:SENSe[1]:NPLCycles <n> Set speed (PLC)

<b>Parameters</b>	<n> =	0.01 to 10	Power-line cycles per integration
		DEFault	1
		MINimum	0.01
		MAXimum	10

<b>Query</b>	:NPLCycles?	Query programmed PLC value
	:NPLCycles? DEFault	Query *RST default PLC
	:NPLCycles? MINimum	Query minimum PLC
	:NPLCycles? MAXimum	Query maximum PLC

**Description** This command is used to set the integration period (speed) for voltage, current, and DVM measurements. NPLC (number of power line cycles) expresses the integration period by basing it on the power line frequency. For example, for a PLC of 1, the integration period would be 1/60 (for 60Hz line power) which is 16.67 msec.

The integration period for pulse-current measurements is set using the :PCURrent:TIME commands. For long integration measurements, use :LINTegration:TIME.

### :AVERage <NRf>

:SENSe[1]:AVERage <NRf> Specify average count

<b>Parameters</b>	<NRf> =	1 to 10	Specify average count
-------------------	---------	---------	-----------------------

<b>Query</b>	:AVERage?	Query filter count
--------------	-----------	--------------------

**Description** This command is used to specify the average count for voltage, current, and DVM measurements.

When requesting a single reading (:FETCh?, :READ?, or :MEASure?), average count specifies the number of measurement conversions to average for the reading. For example, with the average count set to 10, :READ? will trigger 10 measurement conversions and return (and display) the average of those 10 conversions.

When requesting an array of readings (:FETCh:ARRay?, :READ:ARRay?, or :MEASure:ARRay?), average count specifies the number of measurement conversions to place in the array. For example, with the average count set to 10, :READ:ARRay? will trigger 10 measurements and return all 10 readings.

**NOTE** For pulse-current measurements, use the :PCURrent:AVERage command to specify the average count (see “Pulse-current commands”).

## Current range commands

### **[:UPPer] <n>**

:SENSe[1]:CURRent[:DC]:RANGe[:UPPer] <n>                      Select current measurement range

<b>Parameters</b>	<n> =	0 to 5	Expected reading in amps
		DEFault	5A range
		MINimum	5mA range
		MAXimum	5A range

<b>Query</b>	:RANGe?	Query measurement range
	:RANGe? DEFault	Query *RST default range
	:RANGe? MINimum	Query lowest range
	:RANGe? MAXimum	Query highest range

**Description**      This command is used to manually select the measurement range for current measurements. The range is selected by specifying the expected current reading. The instrument will then go to the most sensitive range (5mA or 5A) that will accommodate that reading. For example, if you expect a reading of approximately 100ma, then let <n> = 0.1 (or 100e-3) in order to select the 5A range.

*NOTE*      All pulse-current and long integration measurements are done on the 5A range.

### **:AUTO <b>**

:SENSe[1]:CURRent[:DC]:RANGe:AUTO <b>

<b>Parameters</b>	<b> =	1 or ON	Enable auto range
		0 or OFF	Disable auto range

<b>Query</b>	:AUTO?	Query auto range (on or off)
--------------	--------	------------------------------

**Description**      This command is used to control auto ranging. When enabled, the instrument automatically goes to the most sensitive range (5mA or 5A) to perform the current measurement.

The auto range command (:RANGe:AUTO <b>) is coupled to the command that manually selects the current measurement range (:RANGe <n>). When auto range is enabled, the parameter value for :RANGe <n> changes to the automatically selected range value. If you then disable auto range, the instrument will remain at the automatically selected range. When a valid :RANGe <n> command is sent, auto range disables.

## Pulse-current commands

### **:MODE <name>**

:SENSe[1]:PCURrent:MODE <name> Select pulse-current measurement mode

<b>Parameters</b>	<name> =	HIGH	Measure peak current
		LOW	Measure idle current
		AVERAge	Measure average transmit current

**Query** :MODE? Query pulse-current measurement mode

**Description** This command is used to select the pulse-current measurement mode. With HIGH selected, the measurement conversion is performed at the peak of each pulse. With LOW selected, the measurement conversion is performed at pulse low. With AVERAge mode selected, the measurement conversion encompasses both the high and low periods of the pulse to determine the average current.

The :PCURrent:AVERAge command is used to specify the average count for the measurements.

The :PCURrent:TIME commands are used to set the integration times for the pulse-current measurement modes.

### **:AVERAge <NRf>**

:SENSe[1]:PCURrent:AVERAge <NRf> Specify pulse count

<b>Parameters</b>	<NRf> =	1 to 100	Specify number of pulse readings to average. (sens:pcur:sync:stat ON)
	<NRf> =	1 to 5000	Specify number of readings to take to digitize the pulse. (sens:pcur:sync:stat OFF)

**Query** :AVERAge? Query pulse count

**Description** This command is used to specify the average count for pulse-current measurements.

When requesting a single reading (:FETCh?, :READ?, or :MEASure?), average count specifies the number of pulse-current measurement conversions to average for the reading. For example, with the average count set to 10, :READ? will trigger 10 pulse-current measurement conversions and return (and display) the average of those 10 conversions.

When requesting an array of readings (:FETCh:ARRAy?, :READ:ARRAy?, or :MEASure:ARRAy?), average count specifies the number of pulse-current measurement conversions to place in the array. For example, with the average count set to 10, :READ:ARRAy? will trigger 10 measurements and return all 10 readings.

## :TIME commands

### :HIGH <NRf> :LOW <NRf> :AVERAge <NRf>

:SENSe[1]:PCURrent:TIME:HIGH <NRf>                      Set integration time for High mode  
 :SENSe[1]:PCURrent:TIME:LOW <NRf>                      Set integration time for Low mode  
 :SENSe[1]:PCURrent:TIME:AVERAge <NRf>                      Set integration time for Average mode

**Parameters**                      <NRf> = 33.33E-06 to 0.8333                      Integration time in seconds

**Query**                      HIGH?                      Query integration time for High mode  
                                     LOW?                      Query integration time for Low mode  
                                     AVERAge?                      Query integration time for Average mode

**Description**                      These commands are used to manually set the integration time (speed) for the three pulse-current measurement modes: High mode, Low mode, and Average mode.

In general, the longer the integration period, the more accurate the measurement. However, you must make sure that an integration period does not extend into the wrong portion of the pulse or into the next pulse. Be sure to factor in trigger delay when determining integration times.

Integration times can instead be set automatically by the Model 2304A (see :AUTO).

The integration period for voltage, current, and DVM measurements is set using the :NPLCycles command.

### :AUTO

:SENSe[1]:PCURrent:TIME:AUTO                      Set integration period automatically

**Description**                      Use this command to automatically set the integration times for pulse-current measurements. When this action command is sent, the instrument measures the high and low periods of the detected pulse and sets appropriate high, low, and average integration times. This feature can detect pulses from 80µsec to 833msec.

These three integration times apply for all subsequent pulse measurements until this command is again sent or the times are changed manually.





**:DElay <NRf>**

:SENSe[1]:PCURrent:SYNChronize:DElay <NRf> Set trigger delay (10 $\mu$ sec resolution)

**Parameters** <NRf> = 0 to 0.1 Trigger delay in seconds

**Query** :DElay? Query trigger delay

**Description** This command is used to set the trigger delay for pulse-current measurements. After detecting the pulse based on the trigger level setting, the reading conversion occurs after the delay period expires.

The smallest step size for trigger delay is 10 $\mu$ sec. If you specify a smaller step size, it is adjusted up to the next 10 $\mu$ sec step value. For example, 43 $\mu$ sec is adjusted up to 50 $\mu$ sec.

## Long integration commands

The following commands are used to configure long integration current measurements. The long integration current measurement function is selected using the :SENSe:FUNcTION command. For more information on these measurements, see Section 2, “Long integration current measurements.” When triggering long integration readings with high long integration times, wait enough time for readings to complete before addressing the power supply to talk.

**:TIME <NRf>**

:SENSe[1]:LINTegration:TIME <NRf> Set integration time manually

**Parameters** <NRf> = 0.850000 to 60 Specify integration time (in seconds) for 60Hz power line frequency.  
0.840000 to 60 Specify integration time (in seconds) for 50Hz power line frequency.

**Query** :TIME? Query integration time period

**Description** This command is used to manually set the long integration time period. Make sure that the integration period does not extend into a pulse that you do not want measured, or an erroneous reading will result.

As shown in “Parameters” the minimum time value depends on the frequency of the power line (60Hz or 50Hz). The time value sent is rounded down to the nearest step value, which is also based on power line frequency. For 60Hz, the step value is 16.667msec. For 50Hz, the step value is 20msec. For example, for 50Hz, a time of value of 10.025 seconds is between steps. Therefore, the integration time period will round down to 10.020 seconds.

When there is uncertainty about the actual integration time period, use the TIME? query command to read it.

**NOTE** The integration time for long integration measurements can instead be set automatically by the Model 2304A using the TIME:AUTO command.

### **:TIME:AUTO**

:SENSe[1]:LINTegration:TIME:AUTO Set integration time period automatically

**Description** This command automatically sets the integration time period for long integration current measurements. When this action command is sent, the instrument measures the time between the two rising pulse edges and sets an appropriate integration time that will encompass the high and low periods of the pulse.

This integration time applies for all subsequent long integration current measurements until this command is again sent or the time is changed manually.

### **:TLEVel <NRf>**

:SENSe[1]:LINTegration:TLEVel <NRf> Set trigger level

**Parameters** <NRf> = 0 to 5 Specify trigger level in amps  
(5mA resolution)

**Query** :TLEVel? Query trigger level

**Description** This command is used to set the trigger level for long integration measurements. This level defines the minimum current pulse level that is needed to trigger the start of the long integration. For example, if the trigger level is set for 2A, current pulses less than 2A will be ignored.

### **:TEDGe <name>**

:SENSe[1]:LINTegration:TEDGe <name> Select trigger edge

**Parameters** <name> = RISING Trigger on rising pulse edge  
FALLING Trigger falling pulse edge  
NEITHER Pulse edges not used to start  
measurements

**Query** :TEDGe? Query trigger edge selection

**Description** With this command, you can use the pulse edge to trigger the start of the measurement. With RISING selected, the rising edge of a pulse will trigger the start of a measurement. With FALLING selected, the falling edge of a pulse will trigger the start of a measurement. With NEITHER selected, a pulse edge is not used to start the trigger.

Keep in mind that a pulse has to be detected before a rising or falling pulse edge can start a long integration measurement. All pulses that are less than the specified trigger level are ignored. With NEITHER selected, the measurement will start as soon as the 2304A is ready to trigger the reading, since the reading does not sync up to a pulse edge. The previous command (TLEVel) is used to set the pulse detection trigger level.

**:TimeOUT <NRf>**

:SENSe[1]:LINTegration:TimeOUT <NRf> Specify time for timeout message

**Parameters** <NRf> = 1 to 63 Set timeout in seconds

**Query** :TimeOUT? Query length of timeout

**Description** This command is used to specify how long the instrument will search for a pulse before timing out and displaying the “NO PULSE” message. The instrument will continue to search for a pulse, unless SEARCh is disabled (see next command). Timeout is used when TEDGe is set to RISING or FALLING. No search for a pulse is done when NEITHER trigger edge is selected.

**:SEARCh <b>**

:SENSe[1]:LINTegration:SEARCh <b> Control pulse search

**Parameters** <b> = 1 or ON Enable pulse search  
0 or OFF Disable pulse search

**Query** :SEARCh? Query state of pulse search

**Description** This command is used to enable or disable pulse search. With the search enabled, the instrument will continue to search for a pulse after the timeout period expires (see previous command). Therefore, with a high timeout setting and search enabled, the power supply may appear locked up when it is searching for the pulse to start long integration. In addition, the time needed to execute code after timing out, and to start searching for the pulse, is fast compared to timeout settings. Hence, with NO PULSE detection and search enabled, the power supply is particularly searching for the pulse.

With the search disabled, the search will stop after the first timeout period expires. The search can be restarted by enabling the search, or by sending a trigger reading command (such as :READ?).

# SOURce subsystem

This subsystem is used to set the voltage value and configure current limit for the power supply. These commands are summarized in Table 4-6.

## Set voltage value

### VOLTage <n>

[[:SOURce]:VOLTage[:LEVel]][:IMMediate]][:AMPLitude] <n> Set output voltage value

<b>Parameters</b>	<n> =	0 to 20	Set output voltage (in volts)
		MINimum	0V
		MAXimum	-20V
		DEFault	0V

<b>Query</b>	:VOLTage?	Query programmed output voltage
	:VOLTage? DEFault	Query *RST default voltage
	:VOLTage? MINimum	Query lowest allowable voltage
	:VOLTage? MAXimum	Query highest allowable voltage

**Description** This command is used to program the output voltage of the power supply. Voltage can be set from 0 to +20V with 1mV resolution.

*NOTE* If in enhanced output response mode, 15V is the MAXimum setting.

## Configure current limit

### :LIMit <n>

[[:SOURce]:CURRent:LIMit[:VALue] <n> Set current limit value

<b>Parameters</b>	<n> =	0 to 5	Set current limit (in amps)
		MINimum	0A
		MAXimum	+5A
		DEFault	0V

<b>Query</b>	:LIMit?	Query programmed current limit
	:LIMit? DEFault	Query *RST default limit
	:LIMit? MINimum	Query lowest allowable limit
	:LIMit? MAXimum	Query highest allowable limit

**Description** This command is used to set the current limit for the power supply. On the 5A measurement range or with auto range enabled, the maximum current limit setting is 5A. On the 5mA range (auto range disabled), the maximum current limit setting is 1A. Programming resolution is 1.25mA. Output current will not exceed the programmed limit.



# STATus subsystem

The STATus subsystem is used to control the status registers of the Model 2304A. These registers and the overall status structure are explained in “Status structure.” The commands in this subsystem are summarized in Table 4-7.

## Read event registers

### [:EVENT]?

:STATus:MEASurement[:EVENT]?  
 :STATus:QUEStionable[:EVENT]?  
 :STATus:OPERation[:EVENT]?

Read Measurement Event Register  
 Read Questionable Event Register  
 Read Operation Event Register

### Description

These query commands are used to read the event registers. After sending one of these commands and addressing the Model 2304A to talk, a decimal value is sent to the computer. The binary equivalent of this value determines which bits in the appropriate register are set. The event registers are shown in Figures 4-3, 4-4, and 4-5. Note that reading an event register clears the bits in that register.

For example, assume that reading the Measurement Event Register results in an acquired decimal value of 40. The binary equivalent is 101000. For this binary value, bits B3 and B5 of the Measurement Event Register are set.

*Figure 4-3  
 Measurement  
 event register*

Bit Position	B15 - B10	B9	B8 - B6	B5	B4	B3	B2 - B0
Event	—	BF	—	RAV	PTT	ROF	—
Decimal Weighting	—	512 (2 <sup>9</sup> )	—	32 (2 <sup>5</sup> )	16 (2 <sup>4</sup> )	8 (2 <sup>3</sup> )	—
Value	—	0/1	—	0/1	0/1	0/1	—

Value: 1 = Measurement Set  
 0 = Measurement Event Cleared

Events: BF = Buffer Full  
 RAV = Reading Available  
 PTT = Pulse Trigger Timeout  
 ROF = Reading Overflow

*Figure 4-4  
 Questionable  
 event register*

Bit Position	B15 - B9	B8	B7 - B0
Event	—	Cal	—
Decimal Weighting	—	256 (2 <sup>8</sup> )	—
Value	—	0/1	—

Value: 1 = Questionable Event Set  
 0 = Questionable Event Cleared

Events: Cal = Calibration Summary

**Figure 4-5**  
Operation  
event register

Bit Position	B15-B7	B6	B5	B4	B3	B2-B0
Event	—	PSS	HSS	CLT	CL	—
Decimal Weighting	—	64 (2 <sup>6</sup> )	32 (2 <sup>5</sup> )	16 (2 <sup>4</sup> )	8 (2 <sup>3</sup> )	—
Value	—	0/1	0/1	0/1	0/1	—

Value: 1 = Operation Event Set  
0 = Operation Event Cleared

Events: PSS = Power Supply Shutdown  
HSS = Heat Sink Shutdown  
CLT = Current Limit Tripped  
CL = Current Limit

### Measurement event register

**Bit B0 thru B2** — Not used.

**Bit B3, Reading Overflow (ROF)** — Set bit indicates that the voltage or current reading exceeds the measurement range of the instrument.

**Bit B4, Pulse Trigger Timeout (PTT)** — Set bit indicates that a current pulse has not been detected.

**Bit B5, Reading Available (RAV)** — Set bit indicates that a reading was taken and processed.

**Bits B6 thru B8** — Not used.

**Bit B9, Buffer Full (BF)** — Set bit indicates that the specified number of readings (average count) has been taken.

**Bits B10 through B15** — Not used.

### Questionable event register

**Bits B0 through B7** — Not used.

**Bit B8, Calibration Summary (Cal)** — Set bit indicates that an invalid calibration constant was detected during the power-up sequence. This error will clear after successful calibration of the instrument.

**Bits B9 through B15** — Not used.

### Operation event register

**Bits B0 thru B2** — Not used.

**Bit B3, Current Limit (CL)** — Set bit indicates that the output is in current limit. This bit clears when the instrument is no longer in current limit.

**Bit B4, Current Limit Tripped (CLT)** — Set bit indicates that the output has turned off due to a current limit condition. This bit clears when the output is turned back on.

**Bit B5, Heat Sink Shutdown (HSS)** — This bit indicates that the output has turned off due to overheating. After the instrument is allowed to cool down, the output can be turned back on, and this bit will clear.

**Bit B6, Power Supply Shutdown (PSS)** — This bit indicates that the output has turned off due to an overload and/or overheat condition. This typically indicates that the user tried to exceed the power output capability of the unit.

**Bits B7 through B15** — Not used.

## Program event enable registers

### :ENABLE <NRf>

:STATus:MEASurement:ENABLE <NRf>	Program Measurement Event Enable Register
:STATus:QUEStionable:ENABLE <NRf>	Program Questionable Event Enable Register
:STATus:OPERation:ENABLE <NRf>	Program Operation Event Enable Register

<b>Parameters</b>	<NRf> =	0	Clear register
		1	Set bit B0
		2	Set bit B1
		4	Set bit B2
		8	Set bit B3
		16	Set bit B4
		32	Set bit B5
		64	Set bit B6
		256	Set bit B8
		512	Set bit B9
		1024	Set bit B10

**Query**            ENABLE?                            Query enable register

**Description**    These commands are used to set the contents of the event enable registers (see Figures 4-6, 4-7, and 4-8). An :ENABLE command is sent with the decimal equivalent of the binary value that determines the desired state (0 or 1) of each bit in the appropriate register.

Each event enable register is used as a mask for events (see [:EVENT] for descriptions of events). When a bit in an event enable register is cleared (0), the corresponding bit in the event register is masked and thus, cannot set the corresponding summary bit of the next register set in the status structure.

Conversely, when a bit in an event enable register is set (1), the corresponding bit in the event register is unmasked. When the unmasked bit in the event register sets, the summary bit of the next register set in the status structure will set.

The decimal weighting of the bits for each event enable register are included in Figures 4-6, 4-7, and 4-8. The sum of the decimal weights of the bits that you wish to set is sent as the parameter (<NRf>) for the appropriate :ENABLE command. For example, to enable current limit and current limit trip events, set the CL and CLT bits of the Operation Event Enable Register using the following program message:

```
:stat:oper:enab 24
```

```
where:  CL (bit B3) =   8
         CLT (bit B4) =  16
         <NRf> =     24
```



**Figure 4-6**  
Measurement event  
enable register

Bit Position	B15 - B10	B9	B8 - B6	B5	B4	B3	B2 - B0
Event	—	BF	—	RAV	PTT	ROF	—
Decimal Weighting	—	512 (2 <sup>9</sup> )	—	32 (2 <sup>5</sup> )	16 (2 <sup>4</sup> )	8 (2 <sup>3</sup> )	—
Value	—	0/1	—	0/1	0/1	0/1	—

Value: 1 = Enable Measurement Event  
0 = Disable Measurement Event

Events: BF = Buffer Full  
RAV = Reading Available  
PTT = Pulse Trigger Timeout  
ROF = Reading Overflow

**Figure 4-7**  
Questionable event  
enable register

Bit Position	B15 - B9	B8	B7 - B0
Event	—	Cal	—
Decimal Weighting	—	256 (2 <sup>8</sup> )	—
Value	—	0/1	—

Value: 1 = Enable Questionable Event  
0 = Disable Questionable Event

Events: Cal = Calibration Summary

**Figure 4-8**  
Operation event  
enable register

Bit Position	B15-B7	B6	B5	B4	B3	B2-B0
Event	—	PSS	HSS	CLT	CL	—
Decimal Weighting	—	64 (2 <sup>6</sup> )	32 (2 <sup>5</sup> )	16 (2 <sup>4</sup> )	8 (2 <sup>3</sup> )	—
Value	—	0/1	0/1	0/1	0/1	—

Value: 1 = Enable Operation Event  
0 = Disable Operation Event

Events: PSS = Power Supply Shutdown  
HSS = Heat Sink Shutdown  
CLT = Current Limit Tripped  
CL = Current Limit

## Read condition registers

### :CONDition?

:STATus:MEASurement:CONDition?	Read Measurement Condition
:STATus:QUEStionable:CONDition?	Read Questionable Register
:STATus:OPERation:CONDition?	Read Operation Condition

**Description** These query commands are used to read the contents of the condition registers. Each set of event registers (except the Standard Event Register set) has a condition register. A condition register is similar to its corresponding event register, except it is a real-time register that constantly updates to reflect the present operating status of the instrument. See [:EVENT] for register bit descriptions.

After sending one of these commands and addressing the Model 2304A to talk, a decimal value is sent to the computer. The binary equivalent of this decimal value indicates which bits in the register are set.

For example, if sending :stat:meas:cond? returns a decimal value of 32 (binary 10000), bit B5 of the Measurement Condition Register is set indicating that a reading is available.

## Select default conditions

### :PRESet

:STATus:PRESet	Return registers to default conditions
----------------	--

**Description** When this command is sent, the following SCPI event registers are cleared to zero (0):

- Operation Event Enable Register.
- Event Enable Register.
- Measurement Event Enable Register.

**NOTE** *The Standard Event Register is not affected by this command.*

## Error queue

### [NEXT]?

:STATUS:QUEue[:NEXT]?

Read Error Queue

**Description** As error and status messages occur, they are placed into the Error Queue. This query command is used to read those messages.

The Error Queue is a first-in, first-out (FIFO) register. Every time you read the queue, the “oldest” message is read, and that message is then removed from the queue. The queue will hold up to ten messages. If the queue becomes full, the “350, ‘Queue Overflow’” message will occupy the last memory location in the register. On power-up, the Error Queue is empty. When the Error Queue is empty, the “0, ‘No error’” message is placed in the Error Queue.

The messages in the queue are preceded by a number. Negative (-) numbers are used for SCPI defined messages, and positive (+) numbers are used for Keithley defined messages. Table 3-2 lists the messages.

After this command is sent and the Model 2304A is addressed to talk, the “oldest” message in the queue is sent to the computer.

**NOTE** *The :STATUS:QUEue[:NEXT]? query command performs the same function as the :SYSTEM:ERROR? query command (see System subsystem).*

### :CLEAR

:STATUS:QUEue:CLear

Clear Error Queue

**Description** This action command is used to clear the Error Queue of messages.

### ENABLE <list>

:STATUS:QUEue:ENABle &lt;list&gt;

Enable messages for Error Queue

**Parameters** <list> = (numlist)  
where: numlist is a specified list of messages that you wish to enable for the Error.

**Query** :ENABle? Query list of enabled messages

**Description** On power-up, all error messages are enabled and will go into the Error Queue as they occur. Status messages are not enabled and will not go into the queue. This command is used to specify which messages you want enabled. Messages not specified will be disabled and prevented from entering the queue.

When this command is sent, all messages will first be disabled, then the messages specified in the list will be enabled. Thus, the returned list (:ENABle?) will contain all the enabled messages.

Messages are specified by numbers (see Table 3-2). The following examples show various forms for expressing a message numlist:

```
numlist =   -110           Single message.
            -110:-222      Range of messages (-110 through 222).
            -110:-222, -230 Range entry and single entry by a comma.
```

**NOTE** To disable all messages from entering the Error Queue, send the `:stat:que:enab()` command.

### **DISable <list>**

`:STATus:QUEue:DISable <list>` Disable messages for Error Queue

**Parameters** <list> = (numlist)  
where: numlist is a specified list of messages that you wish to disable for the Error Queue.

**Query** :DISable? Query list of disabled messages

**Description** On power-up, all error messages are enabled and will go into the Error Queue as they occur. Status messages are not enabled and will not go into the queue. This command is used to specify which messages you want disabled. Disabled messages are prevented from going into the Error Queue. Messages are specified by numbers (see Table 3-2). See `:QUEue:ENABle` for examples to express a numlist.

## **:SYSTEM subsystem**

The SYSTEM subsystem contains miscellaneous commands that are summarized in Table 4-8.

### **:POSetup**

`:SYSTEM:POSetup <name>` Program power-on defaults

**Parameters** <name> = RST Power-up to \*RST defaults  
SAV0 Power-up to setup stored at memory location 0  
SAV1 Power-up to setup stored at memory location 1  
SAV2 Power-up to setup stored at memory location 2  
SAV3 Power-up to setup stored at memory location 3  
SAV4 Power-up to setup stored at memory location 4

**Query** :POSetup? Query power-on setup

**Description** This command is used to select the power-on defaults. With RST selected, the instrument powers up to the \*RST default conditions. Default conditions are listed in the SCPI tables (Tables 4-2 through 4-8). Note that :OUTPUT ON cannot be saved, therefore, the power supply always powers on with the output OFF.

With the SAV0-4 parameters specified, the instrument powers-on to the setup that is saved in the specified location using the \*SAV command.

### **:LFRequency?**

:SYSTem:LFRequency?

**Description** Use this command to read the line frequency.

### **:ERRor?**

:SYSTem:ERRor?

Read Error Queue

**Description** As error and status messages occur, they are placed into the Error Queue. This query command is used to read those messages. The Error Queue is a first-in, first-out (FIFO) register that can hold up to ten messages. Every time you read the queue, the “oldest” message is read and that message is then removed from the queue.

If the queue becomes full, the 350, Queue Overflow message occupies the last memory location in the register. On power-up, the queue is empty. When the Error Queue is empty, the 0, No error message is placed in the Error Queue.

The messages in the queue are preceded by a number. Negative (-) numbers are used for SCPI defined messages, and positive (+) numbers are used for Keithley defined messages. Table 3-2 lists the messages.

**NOTE** The :SYSTem:ERRor? query command performs the same function as the :STATus:QUEue? query command (see “STATus subsystem”).

### **:CLEar**

:SYSTem:CLEar

Clear Error Queue

**Description** This command is used to clear the Error Queue of messages.

### **:VERSion**

:SYSTem:VERSion?

Read SCPI version

**Description** This query command is used to read the version of the SCPI standard being used by the Model 2304A. Example code:

1996.0

The above response message indicates the version of the SCPI standard.

# A Specifications

---

---

## DC VOLTAGE OUTPUT (1 Year, 23°C ± 5°C)

### OUTPUT VOLTAGE:

- 0 to +20VDC (for Normal Output Response).
- 0 to +15VDC (for Enhanced Output Response).

**OUTPUT ACCURACY:** ±(0.05% + 10mV).

**PROGRAMMING RESOLUTION:** 5mV.

**READBACK ACCURACY<sup>1</sup>:** ±(0.05% + 10mV).

**READBACK RESOLUTION:** 1mV.

**OUTPUT VOLTAGE SETTling TIME:** 5ms to within stated accuracy.

**LOAD REGULATION:** 0.01% + 2mV.

**LINE REGULATION:** 0.5mV.

**STABILITY<sup>2</sup>:** 0.01% + 0.5mV.

### TRANSIENT RESPONSE TO 1000% LOAD CHANGE:

#### NORMAL MODE:

- Transient Recovery Time<sup>3</sup>:** <50µs to within 100mV of previous level.  
<100µs to within 20mV of previous level.

#### ENHANCED MODE:

- Transient Recovery Time<sup>3,4</sup>:** <40µs to within 100mV of previous level.  
<80µs to within 20mV of previous level.

- Transient Voltage Drop:** <100mV, typical.<sup>3</sup>  
<200mV, typical.<sup>4</sup>

**REMOTE SENSE:** Automatic, 2V max. drop in each lead. Add 2mV to the voltage load regulation specification for each 1V change in the negative output lead due to load current change.

---

## DC CURRENT (1 Year, 23°C ± 5°C)

**OUTPUT CURRENT:** 5A max. (not intended to be operated in parallel).

**COMPLIANCE ACCURACY:** ±(0.16% + 5mA)<sup>5</sup>.

**PROGRAMMED COMPLIANCE RESOLUTION:** 1.25mA.

### READBACK ACCURACY

**5A range:** ±(0.2% + 1mA). **5mA range:** ±(0.2% + 1µA).

### READBACK RESOLUTION

**5A range:** 100µA. **5mA range:** 0.1µA.

### CURRENT SINK CAPACITY:

- 3A max. (for Normal Output Response).
- 1A<sup>6</sup> (for Enhanced Output Response).

**LOAD REGULATION:** 0.01% + 1mA.

**LINE REGULATION:** 0.5mA.

**STABILITY<sup>4</sup>:** 0.01% + 50µA.

---

## DIGITAL VOLTMETER INPUT(1 Year, 23°C ± 5°C)

**INPUT VOLTAGE RANGE:** 0 to +20VDC.

**INPUT IMPEDANCE:** 10<sup>10</sup>Ω typical.

**MAXIMUM VOLTAGE (either input terminal) WITH RESPECT TO OUTPUT LOW:** -3V, +22V.

**READING ACCURACY<sup>1</sup>:** ±(0.05% + 10mV).

**READING RESOLUTION:** 1mV.

---

## DC GENERAL

**MEASUREMENT TIME CHOICES:** 0.01 to 10 PLC<sup>7</sup>, in 0.01PLC steps.

**AVERAGE READINGS:** 1 to 10.

**READING TIME<sup>1,8,9</sup>:** 31ms, typical.

---

## PULSE CURRENT MEASUREMENT OPERATION

**TRIGGER LEVEL:** 5mA to 5A, in 5mA steps.

**TRIGGER DELAY:** 0 to 100ms, in 10 $\mu$ s steps.

**INTERNAL TRIGGER DELAY:** 25 $\mu$ s.

**HIGH/LOW/AVERAGE MODE:**

**Measurement Aperture Settings:** 33.3 $\mu$ s to 833ms, in 33.3 $\mu$ s steps.

**Average Readings:** 1 to 100.

**BURST MODE:**

**Measurement Aperture:** 33.3 $\mu$ s.

**Conversion Rate:** 3600/second, typical.

**Number of Samples:** 1 to 5000.

**Transfer Samples Across IEEE Bus in Binary Mode:** 4800 bytes/ second, typical.

---

## GENERAL

**ISOLATION (low-earth):** 22VDC max.

**PROGRAMMING:** IEEE-488.2 (SCPI).

**USER-DEFINABLE POWER-UP STATES:** 5.

**REAR PANEL CONNECTOR:** 8-position quick disconnect terminal block for output (4), sense (2), and DVM (2).

**TEMPERATURE COEFFICIENT (outside 23°C  $\pm$  5°C):** Derate accuracy specification by (0.1  $\times$  specification)/°C.

**OPERATING TEMPERATURE:**

0° to 50°C (50W<sup>10</sup> normal response, 25W<sup>10</sup> enhanced response).

0° to 35°C (100W<sup>10</sup> normal response, 75W<sup>10</sup> enhanced response).

**STORAGE TEMPERATURE:** -20° to 70°C.

**HUMIDITY:** <80% @ 35°C non-condensing.

**POWER CONSUMPTION:** 200VA max.

**REMOTE DISPLAY/KEYPAD OPTION:** Disables standard front panel.

**DIMENSIONS:** 89mm high  $\times$  213mm wide  $\times$  360mm deep (3½ in  $\times$  8½ in  $\times$  14⅝ in).

**SHIPPING WEIGHT:** 5.4kg (12 lbs).

**INPUT POWER:** 100V–240V AC, 50 or 60Hz (auto detected at power-up).

**WARRANTY:** One year parts and labor on materials and workmanship.

**EMC:** Conforms with European Union Directive directive 89/336/EEC EN 55011, EN 50082-1, EN 61000-3-2 and 61000-3-3, FCC part 15 class B.

**SAFETY:** Conforms with European Union Directive 73/23/EEC EN 61010-1, UL 3111-1.

**ACCESSORIES SUPPLIED:** User manual, service manual, output connector mating terminal (part no. CS-846).

**ACCESSORIES AVAILABLE:** Model 2304-DISP Remote Display/ Keypad (4.6 in  $\times$  2.7 in  $\times$  1.5 in). Includes 2.7m (9 ft) cable and rack mount kit.

<sup>1</sup> PLC = 1.00.

<sup>2</sup> Following 15 minute warm-up, the change in output over 8 hours under ambient temperature, constant load, and line operating conditions.

<sup>3</sup> Remote sense, at output terminals, 1000% load change; typical.

<sup>4</sup> Remote sense, with 4.5m (15 ft) of 16 gauge wire and 1 $\Omega$  resistance in each source lead to simulate typical test environment, up to 1.5A load change.

<sup>5</sup> Minimum current in constant current mode is 6mA.

<sup>6</sup> 60Hz (50Hz).

<sup>7</sup> PLC = Power Line Cycle. 1PLC = 16.7ms for 60Hz operation, 20ms for 50Hz operation.

<sup>8</sup> Display off.

<sup>9</sup> Speed includes measurement and binary data transfer out of GPIB.

Specifications subject to change without notice.



---

# Index

- :DISPlay subsystem 4-9
  - :DATA <a> 4-10
  - :ENABle <b> 4-9
  - :STATe <b> 4-10
- :SYNChronize commands 4-21
  - [:STATe] <b> 4-21
  - :DELay 4-22
  - :TLEVel <NRf> 4-21
- :SYSTem subsystem 4-33
  - :CLEar 4-34
  - :ERRor? 4-34
  - :LFRequency? 4-34
  - :POSetup 4-33
  - :VERsion 4-34
- :TIME commands 4-20
  - :AUTO 4-20
  - :HIGH <NRf> :LOW <NRf>
  - :AVERage <NRf> 4-20

## C

- Command words 3-19
  - Case sensitivity 3-21
  - Long-form and short-form versions 3-21
  - Short-form rules 3-21
- Commands
  - and command parameters 3-19
  - Query 3-20
- Common commands 3-25
  - \*CLS — Clear Status 3-25
  - \*ESE — Event Enable 3-26
  - \*ESE? — Event Enable Query 3-26
  - \*ESR? — Event Status Register
    - Query 3-27
  - \*IDN? — Identification Query 3-29
  - \*OPC — Operation Complete 3-29
  - \*OPC? — Operation Complete
    - Query 3-29
  - \*RCL — Recall 3-30
  - \*RST — Reset 3-30
  - \*SAV — Save 3-30
  - \*SRE — Service Request Enable 3-31
  - \*SRE? — Service Request Enable
    - Query 3-31
  - \*STB? — Status Byte Query 3-32
  - \*TRG — Trigger 3-34
  - \*TST? — Self-Test Query 3-34
  - \*WAI — Wait-to-Continue 3-34

- Configure current limit 4-25
  - :LIMit <n> 4-25
  - :STATe? 4-26
  - :TYPE <name> 4-26
- Current limit 2-11
- Current range commands 4-18
  - [:UPPer] <n> 4-18
  - :AUTO <b> 4-18

## D

- DCL (device clear) 3-6
- Default settings 2-6
- DISPlay command summary 4-5
- Display types 2-7

## E

- Enhanced output response 2-12
- Error queue 4-32
  - [:NEXT]? 4-32
  - :CLEar 4-32
  - :DISable 4-33
  - :ENABle 4-32

## F

- Factory defaults (RST) 2-6
- FORMat command summary 4-5
- FORMat subsystem 4-11
  - [:DATA] <type> 4-11
  - :BORDer <name> 4-14
- Front panel aspects of GPIB operation 3-7
  - Error and status messages 3-7
  - Remote indicator and LOCAL key 3-7
- Front Panel Operation 2-1

## G

- General bus commands 3-4
- General bus commands and associated statements 3-4
- General Information 1-1
- GET (group execute trigger) 3-6
- GPIB bus connections 3-2
- GPIB Operation 3-1
- GTL (go to local) 3-6

## I

- IFC (interface clear) 3-5
- Independent voltage measurements (DVM) 2-12
- Inspection 1-3
- Introduction 1-2, 3-2, 4-2

## L

- LLO (local lockout) 3-5
- Long integration commands 4-22
  - :SEARCh <b> 4-24
  - :TEDGe <name> 4-23
  - :TIME <NRf> 4-22
  - :TIME:AUTO 4-23
  - :TimeOUT <NRf> 4-24
  - :TLEVel <NRf> 4-23
- Long integration current measurements 2-17
  - Determining correct trigger level 2-19
  - General notes 2-19
  - procedure 2-19

## M

- Manual addenda 1-2
- MENU 2-24
  - Rules to navigate 2-25
  - structure 2-25
- MENU structure 2-24
- Message exchange protocol 3-24

## O

- OPERATE 2-10
- OUTPut command summary 4-5
- Output readback 2-11
- OUTPut subsystem 4-15
  - [:STATe]? 4-15
  - :RELay1 <name> 4-15
  - :RELay2 <name> 4-16
  - :RESPonse <name> 4-15

## P

- Power supply overview 2-2
- Power-up 2-4
  - Fuse replacement 2-5
  - Line power connection 2-4
  - sequence 2-5
- Primary address 3-3
- Program event enable registers 4-29
  - :ENABle <NRf> 4-29
- Program messages 3-22
  - Command execution rules 3-23
  - Command path rules 3-23
  - Multiple command messages 3-22
  - Program message terminator (PMT) 3-23
  - Single command messages 3-22
  - Using common and SCPI commands in the same message 3-23

- Programming syntax 3-19
- Pulse-current commands 4-19
  - :AVERAge <NRf> 4-19
  - :MODE <name> 4-19
- Pulse-current measurements 2-12
  - Determining correct trigger level 2-16
  - procedure 2-16
  - Programming examples 2-15
    - Pulse current digitization 2-15
    - Pulse current measurements 2-15
  - Pulse current digitization 2-14

## Q

- Queue
  - Error 3-13
  - Output 3-13
- QuickBASIC 4.5 programming 3-3
  - Universal language driver installation 3-3
  - Using program fragments 3-3

## R

- Read condition registers 4-31
  - :CONDition? 4-31
- Read event registers 4-27
  - [:EVENTi]? 4-27
- Relay control 2-21
  - Connections 2-22
  - Controlling the relays 2-23
- Remote display option 2-8
- REN (remote enable) 3-5
- Response messages 3-24
  - Multiple 3-24
  - Response message terminator (RMT) 3-24
  - Sending 3-24

## S

- Safety symbols and terms 1-2
- SCPI Command Reference 4-1
- SCPI command subsystems reference tables 4-4
- SDC (selective device clear) 3-6
- Select default conditions 4-31
  - :PRESet 4-31
- SENSE command summary 4-6
- SENSE subsystem 4-16
  - :FUNCTion <name> 4-16
- Serial poll and SRQ 3-17
- Service Request Enable Register 3-17
- Set voltage value 4-25
- VOLTage 4-25

---

Setting voltage and current values 2-9  
Editing restrictions 2-10  
Editing shortcuts 2-10  
Procedure to edit voltage and current values 2-9

Signal oriented measurement command summary 4-2

Signal oriented measurement commands 4-2

:FETCh? 4-2

:FETCh:ARRay? 4-2

:MEASure[:<function>]? 4-3

:MEASure:ARRay[:<function>]? 4-3

:READ? 4-3

:READ:ARRay? 4-3

Sink operation 2-20

SOURce command summary 4-7

SOURce subsystem 4-25

SPE, SPD (serial polling) 3-7

Specifications 1-3, A-1

Status and error messages 3-8

Status Byte Register 3-16

STATus command summary 4-8

Status structure 3-11

Condition registers 3-12

Enable registers 3-12

Event registers 3-12

Queues 3-13

Status Byte and Service Request (SRQ). 3-16

STATus subsystem 4-27

SYSTEM command summary 4-9

## T

Test connections 2-8

Typical connections 2-8

## V

Voltage, current, and DVM commands 4-17

:AVERage <NRf> 4-17

:NPLCycles <n> 4-17

## W

Warranty information 1-2

---

# Service Form

Model No. \_\_\_\_\_ Serial No. \_\_\_\_\_ Date \_\_\_\_\_

Name and Telephone No. \_\_\_\_\_

Company \_\_\_\_\_

List all control settings, describe problem and check boxes that apply to problem. \_\_\_\_\_

\_\_\_\_\_

Intermittent                       Analog output follows display                       Particular range or function bad; specify \_\_\_\_\_

IEEE failure                       Obvious problem on power-up                       Batteries and fuses are OK

Front panel operational     All ranges or functions are bad                       Checked all cables

Display or output (check one)

Drifts                       Unable to zero                       Unstable

Overload                       Will not read applied input

Calibration only                       Certificate of calibration required                       Data required

(attach any additional sheets as necessary)

Show a block diagram of your measurement including all instruments connected (whether power is turned on or not). Also, describe signal source.

Where is the measurement being performed? (factory, controlled laboratory, out-of-doors, etc.) \_\_\_\_\_

\_\_\_\_\_

What power line voltage is used? \_\_\_\_\_ Ambient temperature? \_\_\_\_\_ °F

Relative humidity? \_\_\_\_\_ Other? \_\_\_\_\_

Any additional information. (If special modifications have been made by the user, please describe.)

\_\_\_\_\_

\_\_\_\_\_

Be sure to include your name and phone number on this service form.

Specifications are subject to change without notice.

All Keithley trademarks and trade names are the property of Keithley Instruments, Inc. All other trademarks and trade names are the property of their respective companies.



**Keithley Instruments, Inc.**

28775 Aurora Road • Cleveland, Ohio 44139 • 440-248-0400 • Fax: 440-248-6168  
1-888-KEITHLEY (534-8453) • [www.keithley.com](http://www.keithley.com)

**Sales Offices:**

**BELGIUM:** Bergensesteenweg 709 • B-1600 Sint-Pieters-Leeuw • 02-363 00 40 • Fax: 02/363 00 64  
**CHINA:** Yuan Chen Xin Building, Room 705 • 12 Yumin Road, Dewai, Madian • Beijing 100029 • 8610-6202-2886 • Fax: 8610-6202-2892  
**FINLAND:** Tietäjäsentie 2 • 02130 Espoo • Phone: 09-54 75 08 10 • Fax: 09-25 10 51 00  
**FRANCE:** 3, allée des Garays • 91127 Palaiseau Cédex • 01-64 53 20 20 • Fax: 01-60 11 77 26  
**GERMANY:** Landsberger Strasse 65 • 82110 Germering • 089/84 93 07-40 • Fax: 089/84 93 07-34  
**GREAT BRITAIN:** Unit 2 Commerce Park, Brunel Road • Theale • Berkshire RG7 4AB • 0118 929 7500 • Fax: 0118 929 7519  
**INDIA:** Flat 2B, Willocrissa • 14, Rest House Crescent • Bangalore 560 001 • 91-80-509-1320/21 • Fax: 91-80-509-1322  
**ITALY:** Viale San Gimignano, 38 • 20146 Milano • 02-48 39 16 01 • Fax: 02-48 30 22 74  
**JAPAN:** New Pier Takeshiba North Tower 13F • 11-1, Kaigan 1-chome • Minato-ku, Tokyo 105-0022 • 81-3-5733-7555 • Fax: 81-3-5733-7556  
**KOREA:** FL., URI Building • 2-14 Yangjae-Dong • Seocho-Gu, Seoul 137-130 • 82-2-574-7778 • Fax: 82-2-574-7838  
**NETHERLANDS:** Postbus 559 • 4200 AN Gorinchem • 0183-635333 • Fax: 0183-630821  
**SWEDEN:** c/o Regus Business Centre • Frosundaviks Allé 15, 4tr • 169 70 Solna • 08-509 04 679 • Fax: 08-655 26 10  
**SWITZERLAND:** Kriesbachstrasse 4 • 8600 Dübendorf • 01-821 94 44 • Fax: 01-820 30 81  
**TAIWAN:** 1FL., 85 Po Ai Street • Hsinchu, Taiwan, R.O.C. • 886-3-572-9077 • Fax: 886-3-572-9031