

R&S®RTO

Digital Oscilloscope

User Manual



1316.0827.02 – 13

This manual describes the following R&S®RTO models with firmware version 2.00 and higher:

- R&S®RTO1002 (1316.1000K02)
- R&S®RTO1004 (1316.1000K04)
- R&S®RTO1012 (1316.1000K12)
- R&S®RTO1014 (1316.1000K14)
- R&S®RTO1022 (1316.1000K22)
- R&S®RTO1024 (1316.1000K24)
- R&S®RTO1044 (1316.1000K44)

In addition to the base unit, the following options are described:

- R&S®RTO-K1, I²C and SPI (1304.8511.02)
- R&S®RTO-K2, UART (1304.8528.02)
- R&S®RTO-K3, CAN and LIN (1304.8534.02)
- R&S®RTO-K4, FlexRay (1304.8540.02)
- R&S®RTO-K5, Audio Signals (1317.3620.02)
- R&S®RTO-K11, I/Q Software Interface (1317.2975.02)
- R&S®RTO-K31, Power Analysis (1317.5739.02)
- R&S®RTO-K301 Tektronix DPO7000 Emulation mode (1317.2981.02)
- R&S®RTO-B1, MSO (1304.9901.03)
- R&S®RTO-B4, OCXO (1304.8305.02)

The firmware of the instrument makes use of several valuable open source software packages. For information, see the "Open Source Acknowledgement" on the user documentation CD-ROM (included in delivery).

Rohde & Schwarz would like to thank the open source community for their valuable contribution to embedded computing.

© 2014 Rohde & Schwarz GmbH & Co. KG
Mühlendorfstr. 15, 81671 München, Germany
Phone: +49 89 41 29 - 0
Fax: +49 89 41 29 12 164
E-mail: info@rohde-schwarz.com
Internet: www.rohde-schwarz.com

Subject to change – Data without tolerance limits is not binding.

R&S® is a registered trademark of Rohde & Schwarz GmbH & Co. KG.

Trade names are trademarks of the owners.

The following abbreviations are used throughout this manual: R&S®RTO is abbreviated as R&S RTO.

Basic Safety Instructions

Always read through and comply with the following safety instructions!

All plants and locations of the Rohde & Schwarz group of companies make every effort to keep the safety standards of our products up to date and to offer our customers the highest possible degree of safety. Our products and the auxiliary equipment they require are designed, built and tested in accordance with the safety standards that apply in each case. Compliance with these standards is continuously monitored by our quality assurance system. The product described here has been designed, built and tested in accordance with the EC Certificate of Conformity and has left the manufacturer's plant in a condition fully complying with safety standards. To maintain this condition and to ensure safe operation, you must observe all instructions and warnings provided in this manual. If you have any questions regarding these safety instructions, the Rohde & Schwarz group of companies will be happy to answer them.



Furthermore, it is your responsibility to use the product in an appropriate manner. This product is designed for use solely in industrial and laboratory environments or, if expressly permitted, also in the field and must not be used in any way that may cause personal injury or property damage. You are responsible if the product is used for any purpose other than its designated purpose or in disregard of the manufacturer's instructions. The manufacturer shall assume no responsibility for such use of the product.

The product is used for its designated purpose if it is used in accordance with its product documentation and within its performance limits (see data sheet, documentation, the following safety instructions). Using the product requires technical skills and, in some cases, a basic knowledge of English. It is therefore essential that only skilled and specialized staff or thoroughly trained personnel with the required skills be allowed to use the product. If personal safety gear is required for using Rohde & Schwarz products, this will be indicated at the appropriate place in the product documentation. Keep the basic safety instructions and the product documentation in a safe place and pass them on to the subsequent users.











Observing the safety instructions will help prevent personal injury or damage of any kind caused by dangerous situations. Therefore, carefully read through and adhere to the following safety instructions before and when using the product. It is also absolutely essential to observe the additional safety instructions on personal safety, for example, that appear in relevant parts of the product documentation. In these safety instructions, the word "product" refers to all merchandise sold and distributed by the Rohde & Schwarz group of companies, including instruments, systems and all accessories. For product-specific information, see the data sheet and the product documentation.

Safety labels on products

The following safety labels are used on products to warn against risks and dangers.

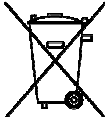
Symbol	Meaning	Symbol	Meaning
	Notice, general danger location Observe product documentation	○	ON/OFF supply voltage
	Caution when handling heavy equipment	⏻	Standby indication
	Danger of electric shock	— — —	Direct current (DC)

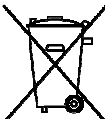
Basic Safety Instructions

Symbol	Meaning	Symbol	Meaning
	Warning! Hot surface		Alternating current (AC)
	Protective conductor terminal		Direct/alternating current (DC/AC)
	Ground		Device fully protected by double (reinforced) insulation
	Ground terminal		EU labeling for batteries and accumulators For additional information, see section "Waste disposal/Environmental protection", item 1.
	Be careful when handling electrostatic sensitive devices		EU labeling for separate collection of electrical and electronic devices For additional information, see section "Waste disposal/Environmental protection", item 2.
	Warning! Laser radiation For additional information, see section "Operation", item 7.		

Signal words and their meaning

The following signal words are used in the product documentation in order to warn the reader about risks and dangers.



Indicates a hazardous situation which, if not avoided, will result in death or serious injury.



Indicates a hazardous situation which, if not avoided, could result in death or serious injury.



Indicates a hazardous situation which, if not avoided, could result in minor or moderate injury.



Indicates information considered important, but not hazard-related, e.g. messages relating to property damage.
In the product documentation, the word ATTENTION is used synonymously.

These signal words are in accordance with the standard definition for civil applications in the European Economic Area. Definitions that deviate from the standard definition may also exist in other economic areas or military applications. It is therefore essential to make sure that the signal words described here are always used only in connection with the related product documentation and the related product. The use of signal words in connection with unrelated products or documentation can result in misinterpretation and in personal injury or material damage.

Basic Safety Instructions

Operating states and operating positions

The product may be operated only under the operating conditions and in the positions specified by the manufacturer, without the product's ventilation being obstructed. If the manufacturer's specifications are not observed, this can result in electric shock, fire and/or serious personal injury or death. Applicable local or national safety regulations and rules for the prevention of accidents must be observed in all work performed.

1. Unless otherwise specified, the following requirements apply to Rohde & Schwarz products: predefined operating position is always with the housing floor facing down, IP protection 2X, use only indoors, max. operating altitude 2000 m above sea level, max. transport altitude 4500 m above sea level. A tolerance of $\pm 10\%$ shall apply to the nominal voltage and $\pm 5\%$ to the nominal frequency, overvoltage category 2, pollution severity 2.
2. Do not place the product on surfaces, vehicles, cabinets or tables that for reasons of weight or stability are unsuitable for this purpose. Always follow the manufacturer's installation instructions when installing the product and fastening it to objects or structures (e.g. walls and shelves). An installation that is not carried out as described in the product documentation could result in personal injury or even death.
3. Do not place the product on heat-generating devices such as radiators or fan heaters. The ambient temperature must not exceed the maximum temperature specified in the product documentation or in the data sheet. Product overheating can cause electric shock, fire and/or serious personal injury or even death.

Electrical safety

If the information on electrical safety is not observed either at all or to the extent necessary, electric shock, fire and/or serious personal injury or death may occur.

1. Prior to switching on the product, always ensure that the nominal voltage setting on the product matches the nominal voltage of the AC supply network. If a different voltage is to be set, the power fuse of the product may have to be changed accordingly.
2. In the case of products of safety class I with movable power cord and connector, operation is permitted only on sockets with a protective conductor contact and protective conductor.
3. Intentionally breaking the protective conductor either in the feed line or in the product itself is not permitted. Doing so can result in the danger of an electric shock from the product. If extension cords or connector strips are implemented, they must be checked on a regular basis to ensure that they are safe to use.
4. If there is no power switch for disconnecting the product from the AC supply network, or if the power switch is not suitable for this purpose, use the plug of the connecting cable to disconnect the product from the AC supply network. In such cases, always ensure that the power plug is easily reachable and accessible at all times. For example, if the power plug is the disconnecting device, the length of the connecting cable must not exceed 3 m. Functional or electronic switches are not suitable for providing disconnection from the AC supply network. If products without power switches are integrated into racks or systems, the disconnecting device must be provided at the system level.
5. Never use the product if the power cable is damaged. Check the power cables on a regular basis to ensure that they are in proper operating condition. By taking appropriate safety measures and carefully laying the power cable, ensure that the cable cannot be damaged and that no one can be hurt by, for example, tripping over the cable or suffering an electric shock.

Basic Safety Instructions

6. The product may be operated only from TN/TT supply networks fuse-protected with max. 16 A (higher fuse only after consulting with the Rohde & Schwarz group of companies).
7. Do not insert the plug into sockets that are dusty or dirty. Insert the plug firmly and all the way into the socket provided for this purpose. Otherwise, sparks that result in fire and/or injuries may occur.
8. Do not overload any sockets, extension cords or connector strips; doing so can cause fire or electric shocks.
9. For measurements in circuits with voltages $V_{rms} > 30$ V, suitable measures (e.g. appropriate measuring equipment, fuse protection, current limiting, electrical separation, insulation) should be taken to avoid any hazards.
10. Ensure that the connections with information technology equipment, e.g. PCs or other industrial computers, comply with the IEC60950-1/EN60950-1 or IEC61010-1/EN 61010-1 standards that apply in each case.
11. Unless expressly permitted, never remove the cover or any part of the housing while the product is in operation. Doing so will expose circuits and components and can lead to injuries, fire or damage to the product.
12. If a product is to be permanently installed, the connection between the protective conductor terminal on site and the product's protective conductor must be made first before any other connection is made. The product may be installed and connected only by a licensed electrician.
13. For permanently installed equipment without built-in fuses, circuit breakers or similar protective devices, the supply circuit must be fuse-protected in such a way that anyone who has access to the product, as well as the product itself, is adequately protected from injury or damage.
14. Use suitable overvoltage protection to ensure that no overvoltage (such as that caused by a bolt of lightning) can reach the product. Otherwise, the person operating the product will be exposed to the danger of an electric shock.
15. Any object that is not designed to be placed in the openings of the housing must not be used for this purpose. Doing so can cause short circuits inside the product and/or electric shocks, fire or injuries.
16. Unless specified otherwise, products are not liquid-proof (see also section "Operating states and operating positions", item 1). Therefore, the equipment must be protected against penetration by liquids. If the necessary precautions are not taken, the user may suffer electric shock or the product itself may be damaged, which can also lead to personal injury.
17. Never use the product under conditions in which condensation has formed or can form in or on the product, e.g. if the product has been moved from a cold to a warm environment. Penetration by water increases the risk of electric shock.
18. Prior to cleaning the product, disconnect it completely from the power supply (e.g. AC supply network or battery). Use a soft, non-linting cloth to clean the product. Never use chemical cleaning agents such as alcohol, acetone or diluents for cellulose lacquers.

Operation

1. Operating the products requires special training and intense concentration. Make sure that persons who use the products are physically, mentally and emotionally fit enough to do so; otherwise, injuries or material damage may occur. It is the responsibility of the employer/operator to select suitable personnel for operating the products.

Basic Safety Instructions

2. Before you move or transport the product, read and observe the section titled "Transport".
3. As with all industrially manufactured goods, the use of substances that induce an allergic reaction (allergens) such as nickel cannot be generally excluded. If you develop an allergic reaction (such as a skin rash, frequent sneezing, red eyes or respiratory difficulties) when using a Rohde & Schwarz product, consult a physician immediately to determine the cause and to prevent health problems or stress.
4. Before you start processing the product mechanically and/or thermally, or before you take it apart, be sure to read and pay special attention to the section titled "Waste disposal/Environmental protection", item 1.
5. Depending on the function, certain products such as RF radio equipment can produce an elevated level of electromagnetic radiation. Considering that unborn babies require increased protection, pregnant women must be protected by appropriate measures. Persons with pacemakers may also be exposed to risks from electromagnetic radiation. The employer/operator must evaluate workplaces where there is a special risk of exposure to radiation and, if necessary, take measures to avert the potential danger.
6. Should a fire occur, the product may release hazardous substances (gases, fluids, etc.) that can cause health problems. Therefore, suitable measures must be taken, e.g. protective masks and protective clothing must be worn.
7. Laser products are given warning labels that are standardized according to their laser class. Lasers can cause biological harm due to the properties of their radiation and due to their extremely concentrated electromagnetic power. If a laser product (e.g. a CD/DVD drive) is integrated into a Rohde & Schwarz product, absolutely no other settings or functions may be used as described in the product documentation. The objective is to prevent personal injury (e.g. due to laser beams).
8. EMC classes (in line with EN 55011/CISPR 11, and analogously with EN 55022/CISPR 22, EN 55032/CISPR 32)
 - Class A equipment:
Equipment suitable for use in all environments except residential environments and environments that are directly connected to a low-voltage supply network that supplies residential buildings
Note: Class A equipment is intended for use in an industrial environment. This equipment may cause radio disturbances in residential environments, due to possible conducted as well as radiated disturbances. In this case, the operator may be required to take appropriate measures to eliminate these disturbances.
 - Class B equipment:
Equipment suitable for use in residential environments and environments that are directly connected to a low-voltage supply network that supplies residential buildings

Repair and service

1. The product may be opened only by authorized, specially trained personnel. Before any work is performed on the product or before the product is opened, it must be disconnected from the AC supply network. Otherwise, personnel will be exposed to the risk of an electric shock.

Basic Safety Instructions

- Adjustments, replacement of parts, maintenance and repair may be performed only by electrical experts authorized by Rohde & Schwarz. Only original parts may be used for replacing parts relevant to safety (e.g. power switches, power transformers, fuses). A safety test must always be performed after parts relevant to safety have been replaced (visual inspection, protective conductor test, insulation resistance measurement, leakage current measurement, functional test). This helps ensure the continued safety of the product.

Batteries and rechargeable batteries/cells

If the information regarding batteries and rechargeable batteries/cells is not observed either at all or to the extent necessary, product users may be exposed to the risk of explosions, fire and/or serious personal injury, and, in some cases, death. Batteries and rechargeable batteries with alkaline electrolytes (e.g. lithium cells) must be handled in accordance with the EN 62133 standard.

- Cells must not be taken apart or crushed.
- Cells or batteries must not be exposed to heat or fire. Storage in direct sunlight must be avoided. Keep cells and batteries clean and dry. Clean soiled connectors using a dry, clean cloth.
- Cells or batteries must not be short-circuited. Cells or batteries must not be stored in a box or in a drawer where they can short-circuit each other, or where they can be short-circuited by other conductive materials. Cells and batteries must not be removed from their original packaging until they are ready to be used.
- Cells and batteries must not be exposed to any mechanical shocks that are stronger than permitted.
- If a cell develops a leak, the fluid must not be allowed to come into contact with the skin or eyes. If contact occurs, wash the affected area with plenty of water and seek medical aid.
- Improperly replacing or charging cells or batteries that contain alkaline electrolytes (e.g. lithium cells) can cause explosions. Replace cells or batteries only with the matching Rohde & Schwarz type (see parts list) in order to ensure the safety of the product.
- Cells and batteries must be recycled and kept separate from residual waste. Rechargeable batteries and normal batteries that contain lead, mercury or cadmium are hazardous waste. Observe the national regulations regarding waste disposal and recycling.

Transport

- The product may be very heavy. Therefore, the product must be handled with care. In some cases, the user may require a suitable means of lifting or moving the product (e.g. with a lift-truck) to avoid back or other physical injuries.
- Handles on the products are designed exclusively to enable personnel to transport the product. It is therefore not permissible to use handles to fasten the product to or on transport equipment such as cranes, fork lifts, wagons, etc. The user is responsible for securely fastening the products to or on the means of transport or lifting. Observe the safety regulations of the manufacturer of the means of transport or lifting. Noncompliance can result in personal injury or material damage.
- If you use the product in a vehicle, it is the sole responsibility of the driver to drive the vehicle safely and properly. The manufacturer assumes no responsibility for accidents or collisions. Never use the product in a moving vehicle if doing so could distract the driver of the vehicle. Adequately secure the product in the vehicle to prevent injuries or other damage in the event of an accident.

Instrucciones de seguridad elementales

Waste disposal/Environmental protection

1. Specially marked equipment has a battery or accumulator that must not be disposed of with unsorted municipal waste, but must be collected separately. It may only be disposed of at a suitable collection point or via a Rohde & Schwarz customer service center.
2. Waste electrical and electronic equipment must not be disposed of with unsorted municipal waste, but must be collected separately.
Rohde & Schwarz GmbH & Co. KG has developed a disposal concept and takes full responsibility for take-back obligations and disposal obligations for manufacturers within the EU. Contact your Rohde & Schwarz customer service center for environmentally responsible disposal of the product.
3. If products or their components are mechanically and/or thermally processed in a manner that goes beyond their intended use, hazardous substances (heavy-metal dust such as lead, beryllium, nickel) may be released. For this reason, the product may only be disassembled by specially trained personnel. Improper disassembly may be hazardous to your health. National waste disposal regulations must be observed.
4. If handling the product releases hazardous substances or fuels that must be disposed of in a special way, e.g. coolants or engine oils that must be replenished regularly, the safety instructions of the manufacturer of the hazardous substances or fuels and the applicable regional waste disposal regulations must be observed. Also observe the relevant safety instructions in the product documentation. The improper disposal of hazardous substances or fuels can cause health problems and lead to environmental damage.

For additional information about environmental protection, visit the Rohde & Schwarz website.

Instrucciones de seguridad elementales

¡Es imprescindible leer y cumplir las siguientes instrucciones e informaciones de seguridad!

El principio del grupo de empresas Rohde & Schwarz consiste en tener nuestros productos siempre al día con los estándares de seguridad y de ofrecer a nuestros clientes el máximo grado de seguridad. Nuestros productos y todos los equipos adicionales son siempre fabricados y examinados según las normas de seguridad vigentes. Nuestro sistema de garantía de calidad controla constantemente que sean cumplidas estas normas. El presente producto ha sido fabricado y examinado según el certificado de conformidad de la UE y ha salido de nuestra planta en estado impecable según los estándares técnicos de seguridad. Para poder preservar este estado y garantizar un funcionamiento libre de peligros, el usuario deberá atenerse a todas las indicaciones, informaciones de seguridad y notas de alerta. El grupo de empresas Rohde & Schwarz está siempre a su disposición en caso de que tengan preguntas referentes a estas informaciones de seguridad.

Además queda en la responsabilidad del usuario utilizar el producto en la forma debida. Este producto está destinado exclusivamente al uso en la industria y el laboratorio o, si ha sido expresamente autorizado, para aplicaciones de campo y de ninguna manera deberá ser utilizado de modo que alguna persona/cosa pueda sufrir daño. El uso del producto fuera de sus fines definidos o sin tener en cuenta las instrucciones del fabricante queda en la responsabilidad del usuario. El fabricante no se hace en ninguna forma responsable de consecuencias a causa del mal uso del producto.















Instrucciones de seguridad elementales

Se parte del uso correcto del producto para los fines definidos si el producto es utilizado conforme a las indicaciones de la correspondiente documentación del producto y dentro del margen de rendimiento definido (ver hoja de datos, documentación, informaciones de seguridad que siguen). El uso del producto hace necesarios conocimientos técnicos y ciertos conocimientos del idioma inglés. Por eso se debe tener en cuenta que el producto solo pueda ser operado por personal especializado o personas instruidas en profundidad con las capacidades correspondientes. Si fuera necesaria indumentaria de seguridad para el uso de productos de Rohde & Schwarz, encontraría la información debida en la documentación del producto en el capítulo correspondiente. Guarde bien las informaciones de seguridad elementales, así como la documentación del producto, y entréguelas a usuarios posteriores.



Tener en cuenta las informaciones de seguridad sirve para evitar en lo posible lesiones o daños por peligros de toda clase. Por eso es imprescindible leer detalladamente y comprender por completo las siguientes informaciones de seguridad antes de usar el producto, y respetarlas durante el uso del producto. Deberán tenerse en cuenta todas las demás informaciones de seguridad, como p. ej. las referentes a la protección de personas, que encontrarán en el capítulo correspondiente de la documentación del producto y que también son de obligado cumplimiento. En las presentes informaciones de seguridad se recogen todos los objetos que distribuye el grupo de empresas Rohde & Schwarz bajo la denominación de "producto", entre ellos también aparatos, instalaciones así como toda clase de accesorios. Los datos específicos del producto figuran en la hoja de datos y en la documentación del producto.

Señalización de seguridad de los productos

Las siguientes señales de seguridad se utilizan en los productos para advertir sobre riesgos y peligros.

Símbolo	Significado	Símbolo	Significado
	Aviso: punto de peligro general Observar la documentación del producto		Tensión de alimentación de PUESTA EN MARCHA / PARADA
	Atención en el manejo de dispositivos de peso elevado		Indicación de estado de espera (standby)
	Peligro de choque eléctrico		Corriente continua (DC)
	Advertencia: superficie caliente		Corriente alterna (AC)
	Conexión a conductor de protección		Corriente continua / Corriente alterna (DC/AC)
	Conexión a tierra		El aparato está protegido en su totalidad por un aislamiento doble (reforzado)
	Conexión a masa		Distintivo de la UE para baterías y acumuladores Más información en la sección "Eliminación/protección del medio ambiente", punto 1.

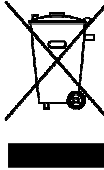
Instrucciones de seguridad elementales

Símbolo	Significado	Símbolo	Significado
	Aviso: Cuidado en el manejo de dispositivos sensibles a la electrostática (ESD)		Distintivo de la UE para la eliminación por separado de dispositivos eléctricos y electrónicos Más información en la sección "Eliminación/protección del medio ambiente", punto 2.
	Advertencia: rayo láser Más información en la sección "Funcionamiento", punto 7.		

Palabras de señal y su significado

En la documentación del producto se utilizan las siguientes palabras de señal con el fin de advertir contra riesgos y peligros.



Indica una situación de peligro que, si no se evita, causa lesiones graves o incluso la muerte.



Indica una situación de peligro que, si no se evita, puede causar lesiones graves o incluso la muerte.



Indica una situación de peligro que, si no se evita, puede causar lesiones leves o moderadas.



Indica información que se considera importante, pero no en relación con situaciones de peligro; p. ej., avisos sobre posibles daños materiales.

En la documentación del producto se emplea de forma sinónima el término CUIDADO.

Las palabras de señal corresponden a la definición habitual para aplicaciones civiles en el área económica europea. Pueden existir definiciones diferentes a esta definición en otras áreas económicas o en aplicaciones militares. Por eso se deberá tener en cuenta que las palabras de señal aquí descritas sean utilizadas siempre solamente en combinación con la correspondiente documentación del producto y solamente en combinación con el producto correspondiente. La utilización de las palabras de señal en combinación con productos o documentaciones que no les correspondan puede llevar a interpretaciones equivocadas y tener por consecuencia daños en personas u objetos.

Estados operativos y posiciones de funcionamiento

El producto solamente debe ser utilizado según lo indicado por el fabricante respecto a los estados operativos y posiciones de funcionamiento sin que se obstruya la ventilación. Si no se siguen las indicaciones del fabricante, pueden producirse choques eléctricos, incendios y/o lesiones graves con posible consecuencia de muerte. En todos los trabajos deberán ser tenidas en cuenta las normas nacionales y locales de seguridad del trabajo y de prevención de accidentes.

Instrucciones de seguridad elementales

1. Si no se convino de otra manera, es para los productos Rohde & Schwarz válido lo que sigue: como posición de funcionamiento se define por principio la posición con el suelo de la caja para abajo, modo de protección IP 2X, uso solamente en estancias interiores, utilización hasta 2000 m sobre el nivel del mar, transporte hasta 4500 m sobre el nivel del mar. Se aplicará una tolerancia de $\pm 10\%$ sobre el voltaje nominal y de $\pm 5\%$ sobre la frecuencia nominal. Categoría de sobrecarga eléctrica 2, índice de suciedad 2.
2. No sitúe el producto encima de superficies, vehículos, estantes o mesas, que por sus características de peso o de estabilidad no sean aptos para él. Siga siempre las instrucciones de instalación del fabricante cuando instale y asegure el producto en objetos o estructuras (p. ej. paredes y estantes). Si se realiza la instalación de modo distinto al indicado en la documentación del producto, se pueden causar lesiones o, en determinadas circunstancias, incluso la muerte.
3. No ponga el producto sobre aparatos que generen calor (p. ej. radiadores o calefactores). La temperatura ambiente no debe superar la temperatura máxima especificada en la documentación del producto o en la hoja de datos. En caso de sobrecalentamiento del producto, pueden producirse choques eléctricos, incendios y/o lesiones graves con posible consecuencia de muerte.

Seguridad eléctrica

Si no se siguen (o se siguen de modo insuficiente) las indicaciones del fabricante en cuanto a seguridad eléctrica, pueden producirse choques eléctricos, incendios y/o lesiones graves con posible consecuencia de muerte.

1. Antes de la puesta en marcha del producto se deberá comprobar siempre que la tensión preseleccionada en el producto coincida con la de la red de alimentación eléctrica. Si es necesario modificar el ajuste de tensión, también se deberán cambiar en caso dado los fusibles correspondientes del producto.
2. Los productos de la clase de protección I con alimentación móvil y enchufe individual solamente podrán enchufarse a tomas de corriente con contacto de seguridad y con conductor de protección conectado.
3. Queda prohibida la interrupción intencionada del conductor de protección, tanto en la toma de corriente como en el mismo producto. La interrupción puede tener como consecuencia el riesgo de que el producto sea fuente de choques eléctricos. Si se utilizan cables alargadores o regletas de enchufe, deberá garantizarse la realización de un examen regular de los mismos en cuanto a su estado técnico de seguridad.
4. Si el producto no está equipado con un interruptor para desconectarlo de la red, o bien si el interruptor existente no resulta apropiado para la desconexión de la red, el enchufe del cable de conexión se deberá considerar como un dispositivo de desconexión. El dispositivo de desconexión se debe poder alcanzar fácilmente y debe estar siempre bien accesible. Si, p. ej., el enchufe de conexión a la red es el dispositivo de desconexión, la longitud del cable de conexión no debe superar 3 m). Los interruptores selectores o electrónicos no son aptos para el corte de la red eléctrica. Si se integran productos sin interruptor en bastidores o instalaciones, se deberá colocar el interruptor en el nivel de la instalación.
5. No utilice nunca el producto si está dañado el cable de conexión a red. Compruebe regularmente el correcto estado de los cables de conexión a red. Asegúrese, mediante las medidas de protección y de instalación adecuadas, de que el cable de conexión a red no pueda ser dañado o de que nadie pueda ser dañado por él, p. ej. al tropezar o por un choque eléctrico.

Instrucciones de seguridad elementales

6. Solamente está permitido el funcionamiento en redes de alimentación TN/TT aseguradas con fusibles de 16 A como máximo (utilización de fusibles de mayor amperaje solo previa consulta con el grupo de empresas Rohde & Schwarz).
7. Nunca conecte el enchufe en tomas de corriente sucias o llenas de polvo. Introduzca el enchufe por completo y fuertemente en la toma de corriente. La no observación de estas medidas puede provocar chispas, fuego y/o lesiones.
8. No sobrecargue las tomas de corriente, los cables alargadores o las regletas de enchufe ya que esto podría causar fuego o choques eléctricos.
9. En las mediciones en circuitos de corriente con una tensión $U_{\text{eff}} > 30 \text{ V}$ se deberán tomar las medidas apropiadas para impedir cualquier peligro (p. ej. medios de medición adecuados, seguros, limitación de tensión, corte protector, aislamiento etc.).
10. Para la conexión con dispositivos informáticos como un PC o un ordenador industrial, debe comprobarse que éstos cumplan los estándares IEC60950-1/EN60950-1 o IEC61010-1/EN 61010-1 válidos en cada caso.
11. A menos que esté permitido expresamente, no retire nunca la tapa ni componentes de la carcasa mientras el producto esté en servicio. Esto pone a descubierto los cables y componentes eléctricos y puede causar lesiones, fuego o daños en el producto.
12. Si un producto se instala en un lugar fijo, se deberá primero conectar el conductor de protección fijo con el conductor de protección del producto antes de hacer cualquier otra conexión. La instalación y la conexión deberán ser efectuadas por un electricista especializado.
13. En el caso de dispositivos fijos que no estén provistos de fusibles, interruptor automático ni otros mecanismos de seguridad similares, el circuito de alimentación debe estar protegido de modo que todas las personas que puedan acceder al producto, así como el producto mismo, estén a salvo de posibles daños.
14. Todo producto debe estar protegido contra sobretensión (debida p. ej. a una caída del rayo) mediante los correspondientes sistemas de protección. Si no, el personal que lo utilice quedará expuesto al peligro de choque eléctrico.
15. No debe introducirse en los orificios de la caja del aparato ningún objeto que no esté destinado a ello. Esto puede producir cortocircuitos en el producto y/o puede causar choques eléctricos, fuego o lesiones.
16. Salvo indicación contraria, los productos no están impermeabilizados (ver también el capítulo "Estados operativos y posiciones de funcionamiento", punto 1). Por eso es necesario tomar las medidas necesarias para evitar la entrada de líquidos. En caso contrario, existe peligro de choque eléctrico para el usuario o de daños en el producto, que también pueden redundar en peligro para las personas.
17. No utilice el producto en condiciones en las que pueda producirse o ya se hayan producido condensaciones sobre el producto o en el interior de éste, como p. ej. al desplazarlo de un lugar frío a otro caliente. La entrada de agua aumenta el riesgo de choque eléctrico.
18. Antes de la limpieza, desconecte por completo el producto de la alimentación de tensión (p. ej. red de alimentación o batería). Realice la limpieza de los aparatos con un paño suave, que no se deshilache. No utilice bajo ningún concepto productos de limpieza químicos como alcohol, acetona o diluyentes para lacas nitrocelulósicas.

Instrucciones de seguridad elementales

Funcionamiento

1. El uso del producto requiere instrucciones especiales y una alta concentración durante el manejo. Debe asegurarse que las personas que manejen el producto estén a la altura de los requerimientos necesarios en cuanto a aptitudes físicas, psíquicas y emocionales, ya que de otra manera no se pueden excluir lesiones o daños de objetos. El empresario u operador es responsable de seleccionar el personal usuario apto para el manejo del producto.
2. Antes de desplazar o transportar el producto, lea y tenga en cuenta el capítulo "Transporte".
3. Como con todo producto de fabricación industrial no puede quedar excluida en general la posibilidad de que se produzcan alergias provocadas por algunos materiales empleados —los llamados alérgenos (p. ej. el níquel)—. Si durante el manejo de productos Rohde & Schwarz se producen reacciones alérgicas, como p. ej. irritaciones cutáneas, estornudos continuos, enrojecimiento de la conjuntiva o dificultades respiratorias, debe avisarse inmediatamente a un médico para investigar las causas y evitar cualquier molestia o daño a la salud.
4. Antes de la manipulación mecánica y/o térmica o el desmontaje del producto, debe tenerse en cuenta imprescindiblemente el capítulo "Eliminación/protección del medio ambiente", punto 1.
5. Ciertos productos, como p. ej. las instalaciones de radiocomunicación RF, pueden a causa de su función natural, emitir una radiación electromagnética aumentada. Deben tomarse todas las medidas necesarias para la protección de las mujeres embarazadas. También las personas con marcapasos pueden correr peligro a causa de la radiación electromagnética. El empresario/operador tiene la obligación de evaluar y señalizar las áreas de trabajo en las que exista un riesgo elevado de exposición a radiaciones.
6. Tenga en cuenta que en caso de incendio pueden desprenderse del producto sustancias tóxicas (gases, líquidos etc.) que pueden generar daños a la salud. Por eso, en caso de incendio deben usarse medidas adecuadas, como p. ej. máscaras antigás e indumentaria de protección.
7. Los productos con láser están provistos de indicaciones de advertencia normalizadas en función de la clase de láser del que se trate. Los rayos láser pueden provocar daños de tipo biológico a causa de las propiedades de su radiación y debido a su concentración extrema de potencia electromagnética. En caso de que un producto Rohde & Schwarz contenga un producto láser (p. ej. un lector de CD/DVD), no debe usarse ninguna otra configuración o función aparte de las descritas en la documentación del producto, a fin de evitar lesiones (p. ej. debidas a irradiación láser).
8. Clases de compatibilidad electromagnética (conforme a EN 55011 / CISPR 11; y en analogía con EN 55022 / CISPR 22, EN 55032 / CISPR 32)
 - Aparato de clase A:
Aparato adecuado para su uso en todos los entornos excepto en los residenciales y en aquellos conectados directamente a una red de distribución de baja tensión que suministra corriente a edificios residenciales.
Nota: Los aparatos de clase A están destinados al uso en entornos industriales. Estos aparatos pueden causar perturbaciones radioeléctricas en entornos residenciales debido a posibles perturbaciones guiadas o radiadas. En este caso, se le podrá solicitar al operador que tome las medidas adecuadas para eliminar estas perturbaciones.
 - Aparato de clase B:
Aparato adecuado para su uso en entornos residenciales, así como en aquellos conectados directamente a una red de distribución de baja tensión que suministra corriente a edificios residenciales.

Instrucciones de seguridad elementales

Reparación y mantenimiento

1. El producto solamente debe ser abierto por personal especializado con autorización para ello. Antes de manipular el producto o abrirlo, es obligatorio desconectarlo de la tensión de alimentación, para evitar toda posibilidad de choque eléctrico.
2. El ajuste, el cambio de partes, el mantenimiento y la reparación deberán ser efectuadas solamente por electricistas autorizados por Rohde & Schwarz. Si se reponen partes con importancia para los aspectos de seguridad (p. ej. el enchufe, los transformadores o los fusibles), solamente podrán ser sustituidos por partes originales. Después de cada cambio de partes relevantes para la seguridad deberá realizarse un control de seguridad (control a primera vista, control del conductor de protección, medición de resistencia de aislamiento, medición de la corriente de fuga, control de funcionamiento). Con esto queda garantizada la seguridad del producto.

Baterías y acumuladores o celdas

Si no se siguen (o se siguen de modo insuficiente) las indicaciones en cuanto a las baterías y acumuladores o celdas, pueden producirse explosiones, incendios y/o lesiones graves con posible consecuencia de muerte. El manejo de baterías y acumuladores con electrolitos alcalinos (p. ej. celdas de litio) debe seguir el estándar EN 62133.

1. No deben desmontarse, abrirse ni triturarse las celdas.
2. Las celdas o baterías no deben someterse a calor ni fuego. Debe evitarse el almacenamiento a la luz directa del sol. Las celdas y baterías deben mantenerse limpias y secas. Limpiar las conexiones sucias con un paño seco y limpio.
3. Las celdas o baterías no deben cortocircuitarse. Es peligroso almacenar las celdas o baterías en estuches o cajones en cuyo interior puedan cortocircuitarse por contacto recíproco o por contacto con otros materiales conductores. No deben extraerse las celdas o baterías de sus embalajes originales hasta el momento en que vayan a utilizarse.
4. Las celdas o baterías no deben someterse a impactos mecánicos fuertes indebidos.
5. En caso de falta de estanqueidad de una celda, el líquido vertido no debe entrar en contacto con la piel ni los ojos. Si se produce contacto, lavar con agua abundante la zona afectada y avisar a un médico.
6. En caso de cambio o recarga inadecuados, las celdas o baterías que contienen electrolitos alcalinos (p. ej. las celdas de litio) pueden explotar. Para garantizar la seguridad del producto, las celdas o baterías solo deben ser sustituidas por el tipo Rohde & Schwarz correspondiente (ver lista de recambios).
7. Las baterías y celdas deben reciclarse y no deben tirarse a la basura doméstica. Las baterías o acumuladores que contienen plomo, mercurio o cadmio deben tratarse como residuos especiales. Respete en esta relación las normas nacionales de eliminación y reciclaje.

Transporte

1. El producto puede tener un peso elevado. Por eso es necesario desplazarlo o transportarlo con precaución y, si es necesario, usando un sistema de elevación adecuado (p. ej. una carretilla elevadora), a fin de evitar lesiones en la espalda u otros daños personales.

Instrucciones de seguridad elementales

2. Las asas instaladas en los productos sirven solamente de ayuda para el transporte del producto por personas. Por eso no está permitido utilizar las asas para la sujeción en o sobre medios de transporte como p. ej. grúas, carretillas elevadoras de horquilla, carros etc. Es responsabilidad suya fijar los productos de manera segura a los medios de transporte o elevación. Para evitar daños personales o daños en el producto, siga las instrucciones de seguridad del fabricante del medio de transporte o elevación utilizado.
3. Si se utiliza el producto dentro de un vehículo, recae de manera exclusiva en el conductor la responsabilidad de conducir el vehículo de manera segura y adecuada. El fabricante no asumirá ninguna responsabilidad por accidentes o colisiones. No utilice nunca el producto dentro de un vehículo en movimiento si esto pudiera distraer al conductor. Asegure el producto dentro del vehículo debidamente para evitar, en caso de un accidente, lesiones u otra clase de daños.

Eliminación/protección del medio ambiente

1. Los dispositivos marcados contienen una batería o un acumulador que no se debe desechar con los residuos domésticos sin clasificar, sino que debe ser recogido por separado. La eliminación se debe efectuar exclusivamente a través de un punto de recogida apropiado o del servicio de atención al cliente de Rohde & Schwarz.
2. Los dispositivos eléctricos usados no se deben desechar con los residuos domésticos sin clasificar, sino que deben ser recogidos por separado.
Rohde & Schwarz GmbH & Co.KG ha elaborado un concepto de eliminación de residuos y asume plenamente los deberes de recogida y eliminación para los fabricantes dentro de la UE. Para desechar el producto de manera respetuosa con el medio ambiente, dirijase a su servicio de atención al cliente de Rohde & Schwarz.
3. Si se trabaja de manera mecánica y/o térmica cualquier producto o componente más allá del funcionamiento previsto, pueden liberarse sustancias peligrosas (polvos con contenido de metales pesados como p. ej. plomo, berilio o níquel). Por eso el producto solo debe ser desmontado por personal especializado con formación adecuada. Un desmontaje inadecuado puede ocasionar daños para la salud. Se deben tener en cuenta las directivas nacionales referentes a la eliminación de residuos.
4. En caso de que durante el trato del producto se formen sustancias peligrosas o combustibles que deban tratarse como residuos especiales (p. ej. refrigerantes o aceites de motor con intervalos de cambio definidos), deben tenerse en cuenta las indicaciones de seguridad del fabricante de dichas sustancias y las normas regionales de eliminación de residuos. Tenga en cuenta también en caso necesario las indicaciones de seguridad especiales contenidas en la documentación del producto. La eliminación incorrecta de sustancias peligrosas o combustibles puede causar daños a la salud o daños al medio ambiente.

Se puede encontrar más información sobre la protección del medio ambiente en la página web de Rohde & Schwarz.

Customer Support

Technical support – where and when you need it

For quick, expert help with any Rohde & Schwarz equipment, contact one of our Customer Support Centers. A team of highly qualified engineers provides telephone support and will work with you to find a solution to your query on any aspect of the operation, programming or applications of Rohde & Schwarz equipment.

Up-to-date information and upgrades

To keep your instrument up-to-date and to be informed about new application notes related to your instrument, please send an e-mail to the Customer Support Center stating your instrument and your wish. We will take care that you will get the right information.

Europe, Africa, Middle East

Phone +49 89 4129 12345
customersupport@rohde-schwarz.com

North America

Phone 1-888-TEST-RSA (1-888-837-8772)
customer.support@rsa.rohde-schwarz.com

Latin America

Phone +1-410-910-7988
customersupport.la@rohde-schwarz.com

Asia/Pacific

Phone +65 65 13 04 88
customersupport.asia@rohde-schwarz.com

China

Phone +86-800-810-8228 /
+86-400-650-5896
customersupport.china@rohde-schwarz.com



Contents

1	Preface	15
1.1	Documentation Overview	15
1.2	Conventions Used in the Documentation	16
1.2.1	Typographical Conventions.....	16
1.2.2	Conventions for Procedure Descriptions.....	16
2	Getting Started	17
2.1	Preparing for Use	17
2.1.1	Unpacking and Checking the Instrument.....	17
2.1.2	Positioning the Instrument.....	18
2.1.3	Starting the Instrument.....	20
2.1.4	Connecting External Devices.....	22
2.2	Instrument Tour	25
2.2.1	Front Panel.....	25
2.2.2	Rear Panel.....	37
2.3	Trying Out the Instrument	39
2.3.1	Displaying a Basic Signal.....	40
2.3.2	Acquiring Data.....	42
2.3.3	Organizing the Display.....	43
2.3.4	Changing the Waveform Scaling and Position.....	47
2.3.5	Zooming into the Display.....	50
2.3.6	Displaying the Waveform History.....	51
2.3.7	Showing Basic Measurement Results.....	53
2.3.8	Performing an FFT Analysis.....	58
2.3.9	Performing Mathematical Calculations.....	61
2.3.10	Performing a Search.....	62
2.3.11	Performing a Mask Test.....	64
2.3.12	Printing and Saving Screenshots.....	67
2.3.13	Saving Data.....	68
2.4	Operating the Instrument	70
2.4.1	Means of Manual Interaction.....	71
2.4.2	Information on the Display.....	72

2.4.3	Using the Toolbar.....	74
2.4.4	Working with Waveforms.....	77
2.4.5	Displaying Results.....	80
2.4.6	Using the Signal bar.....	81
2.4.7	Accessing the Functionality.....	83
2.4.8	Entering Data.....	84
2.4.9	Messages.....	86
2.4.10	Getting Information and Help.....	87
3	Acquisition and Setup.....	90
3.1	Basics.....	90
3.1.1	Vertical System.....	90
3.1.2	Sampling and Acquisition.....	92
3.1.3	Horizontal System.....	96
3.1.4	Probes.....	97
3.2	Setting Up the Waveform.....	101
3.2.1	Setting Up the Signal Input with Autoset.....	101
3.2.2	Adjusting the Signal Input Manually.....	101
3.2.3	Setting the Acquisition.....	102
3.2.4	Starting and Stopping Acquisition.....	102
3.2.5	Using the Roll Mode.....	103
3.2.6	Using Ultra Segmentation.....	104
3.2.7	Using Digital Filters.....	104
3.3	Reference for Acquisition and Setup.....	105
3.3.1	Horizontal Settings.....	105
3.3.2	Vertical Settings.....	116
3.3.3	Probes.....	119
3.3.4	Digital Filter Setup.....	128
3.3.5	Horizontal Accuracy.....	130
4	Triggers.....	133
4.1	Basics of Triggering.....	133
4.2	Setting Up the Trigger.....	135
4.2.1	Configuring the Trigger Event.....	135
4.2.2	Positioning the Trigger.....	135

4.2.3	Using Holdoff.....	136
4.2.4	Setting Up a Trigger Sequence.....	136
4.2.5	Qualifying the Trigger.....	137
4.3	Reference for Triggers.....	137
4.3.1	Events and Trigger Types.....	138
4.3.2	Trigger Qualification.....	163
4.3.3	Noise Reject.....	166
4.3.4	Sequence.....	167
4.3.5	Horizontal Position.....	171
4.3.6	Control.....	173
5	Display.....	177
5.1	Display Customization.....	177
5.1.1	Display Settings.....	177
5.1.2	Adjusting the Display.....	178
5.1.3	Reference for Display Settings.....	183
5.2	Zoom.....	193
5.2.1	Methods of Zooming.....	193
5.2.2	Zooming for Details.....	194
5.2.3	Reference for Zoom.....	200
5.3	XY-diagram.....	204
5.3.1	Displaying an XY-diagram.....	204
5.3.2	Reference for XY-diagram.....	206
5.4	History.....	207
5.4.1	About History.....	207
5.4.2	Using History.....	209
5.4.3	Reference for History.....	211
6	Reference Waveforms.....	214
6.1	Working with Reference Waveforms.....	214
6.2	Reference Waveforms.....	215
6.2.1	Reference tab.....	215
6.2.2	Scaling.....	217
6.2.3	Original Attributes.....	219

7	Measurements	221
7.1	Cursor measurements	221
7.1.1	Manual Measurements with Cursors	221
7.1.2	Performing Cursor Measurements	222
7.1.3	Reference for Cursor Measurements	225
7.2	Automatic Measurements	230
7.2.1	Measurements, Measurement Types, and Results	230
7.2.2	Reference Levels	243
7.2.3	Performing Automatic Measurements	252
7.2.4	Reference for Automatic Measurements	261
8	Mathematics	287
8.1	Mathematical Waveforms	287
8.1.1	Displaying Math Waveforms	287
8.1.2	Math Setup	288
8.2	Mathematical Functions and Formulas	291
8.2.1	Basic Editor	291
8.2.2	Advanced Expressions	293
8.3	FFT Analysis	298
8.3.1	Fundamentals of FFT Analysis	298
8.3.2	Configuring FFT Waveforms	303
8.3.3	FFT Configuration Settings	305
9	Mask Testing	316
9.1	About Mask Testing	316
9.1.1	Results of a Mask Test	316
9.2	Working with Masks	318
9.2.1	Setting Up User Masks	318
9.2.2	Setting Up a Mask Test	322
9.2.3	Configuring the Mask and Hit Display	322
9.2.4	Running a Mask Test	324
9.2.5	Saving and Loading Masks	324
9.2.6	Mask Testing on History Acquisitions	325
9.3	Reference for Masks	325
9.3.1	Test Definition	325

9.3.2	Mask Definition.....	328
9.3.3	Event Actions /Reset	334
9.3.4	Mask Display.....	336
10	Search Functions.....	338
10.1	Overview: Search Definition and Results.....	338
10.1.1	Search Definition.....	338
10.1.2	Search Results.....	339
10.2	Search Setup.....	340
10.2.1	Search Criteria.....	341
10.2.2	Search Parameters.....	342
10.2.3	Configuring the Search Setup.....	351
10.3	Search Gate.....	352
10.3.1	Gate Settings.....	352
10.3.2	Defining the Search Gate.....	354
10.4	Result Presentation.....	355
10.4.1	Result Presentation Settings.....	355
10.4.2	Configuring the Search Results Presentation.....	357
10.5	Noise Reject.....	358
10.5.1	Noise Reject Settings.....	358
10.5.2	Defining Noise Rejection for Searches.....	359
11	Data and Results Management.....	360
11.1	Saving, Loading and Printing Data.....	360
11.1.1	Configuring Printer Output and Printing.....	360
11.1.2	Saving and Loading Waveform Data.....	361
11.1.3	Saving and Loading Settings.....	362
11.1.4	Restoring Settings.....	364
11.1.5	Defining Default File Paths and Names.....	365
11.2	Reference for FILE Settings.....	365
11.2.1	Save/Recall.....	366
11.2.2	Waveforms / Results.....	368
11.2.3	Autonaming.....	385
11.2.4	File Selection Dialog.....	386
11.3	Reference for PRINT Settings.....	387

12	General Instrument Setup.....	391
12.1	Setting Up the Instrument.....	391
12.1.1	Performing a Self-alignment.....	391
12.1.2	Aligning the Touchscreen.....	392
12.1.3	Adjusting Passive Probes.....	392
12.2	Reference for General Instrument Settings.....	393
12.2.1	Setup.....	393
12.2.2	Front Panel Setup.....	402
12.2.3	Self-alignment.....	403
13	Software and Network Operation.....	405
13.1	Operating System.....	405
13.1.1	Virus Protection.....	405
13.1.2	Service Packs and Updates.....	405
13.1.3	Logon.....	406
13.1.4	Accessing Windows functionality.....	406
13.2	Updating the Firmware	407
13.3	Installing Options.....	409
13.3.1	Options in Beta State.....	410
13.4	Operation in a Network.....	410
13.4.1	Setting Up a Network (LAN) Connection.....	410
13.4.2	LXI Configuration.....	413
14	Protocol Analysis (Base Functions and Options R&S RTO-K1 to K5)	419
14.1	Basics of Protocol Analysis.....	419
14.1.1	Configuration - General Settings.....	420
14.1.2	Display.....	420
14.1.3	Label Lists.....	422
14.1.4	Bit Pattern Editor.....	425
14.2	I²C	426
14.2.1	The I ² C Protocol.....	426
14.2.2	I ² C Configuration.....	428
14.2.3	I ² C Trigger.....	430
14.2.4	I ² C Label List.....	435

14.2.5	I ² C Decode Results (Option R&S RTO-K1).....	436
14.3	SPI Bus.....	439
14.3.1	The SPI Protocol.....	439
14.3.2	SPI Configuration.....	440
14.3.3	SPI Trigger.....	444
14.3.4	SPI Decode Results (Option R&S RTO-K1).....	447
14.4	UART / RS232.....	448
14.4.1	The UART / RS232 Interface.....	448
14.4.2	UART Configuration.....	449
14.4.3	UART Trigger.....	452
14.4.4	UART Decode Results (Option R&S RTO-K2).....	454
14.5	CAN (Option R&S RTO-K3).....	457
14.5.1	CAN Configuration.....	457
14.5.2	CAN Trigger.....	459
14.5.3	CAN Label List.....	463
14.5.4	CAN Decode Results.....	465
14.6	LIN (Option R&S RTO-K3).....	467
14.6.1	The LIN Protocol.....	467
14.6.2	LIN Configuration.....	468
14.6.3	LIN Trigger.....	470
14.6.4	LIN Label List.....	473
14.6.5	LIN Decode Results.....	475
14.7	FlexRay (Option R&S RTO-K4).....	476
14.7.1	FlexRay Configuration.....	477
14.7.2	FlexRay Trigger.....	480
14.7.3	FlexRay Label List.....	485
14.7.4	FlexRay Decode Results.....	486
14.8	Audio Signals (Option R&S RTO-K5).....	490
14.8.1	Audio Protocols.....	490
14.8.2	Audio Signal Configuration.....	492
14.8.3	Audio Trigger.....	496
14.8.4	Audio Decode Results.....	499
14.8.5	Track and Trend.....	502

15	Mixed Signal Option (MSO, R&S RTO-B1)	510
15.1	About MSO	511
15.2	Analyzing Digital Signals	515
15.2.1	Using Digital Probes.....	515
15.2.2	Configuring Digital Channels and Parallel Buses.....	515
15.2.3	Setting the Logical Thresholds.....	516
15.2.4	Adjusting the Display of Digital Channels and Parallel Buses.....	516
15.2.5	Triggering on Digital Signals and Parallel Buses.....	517
15.2.6	Performing Measurements on Digital Signals.....	518
15.3	Reference for MSO	518
15.3.1	Parallel Buses - Configuration.....	518
15.3.2	Parallel Buses - Digital Probes.....	523
15.3.3	Parallel Bus - Decode Table.....	523
15.3.4	Digital Resolution.....	524
15.3.5	Trigger Settings for Digital Signals and Parallel Buses.....	524
16	I/Q Software Interface (Option R&S RTO-K11)	536
16.1	I/Q Mode	536
16.2	IQ Sampling Setup	537
16.3	I/Q Data Output	541
16.4	NFC Trigger	543
17	Jitter Analysis and Clock Data Recovery (Options R&S RTO-K12/13)	545
17.1	Jitter Measurements	545
17.1.1	Jitter Wizard.....	545
17.1.2	Jitter Measurement Types.....	546
17.1.3	Jitter Measurement Settings.....	547
17.1.4	Jitter Statistics and Histogram	551
17.1.5	Track of Jitter Measurement Results.....	552
17.1.6	Jitter Spectrum.....	552
17.2	Clock Data Recovery	552
17.2.1	Software CDR	553
17.2.2	Hardware CDR (Option R&S RTO-K13).....	555
17.2.3	Displaying the Recovered Clock Signal.....	557

17.3	Mask Testing on Eye Diagrams.....	557
17.3.1	Mask Definition.....	559
18	Power Analysis (Option R&S RTO-K31).....	562
18.1	Power Measurement Selection.....	562
18.1.1	General Settings.....	563
18.2	Overview of Power Measurement Setup.....	573
18.2.1	Channels Tab.....	573
18.2.2	Settings Tab.....	574
18.2.3	Details Tab.....	575
18.3	Power Quality.....	576
18.3.1	Power Quality Results.....	576
18.3.2	Configuring Power Quality.....	578
18.3.3	Power Quality Settings.....	579
18.4	Inrush Current.....	581
18.4.1	Inrush Current Results.....	581
18.4.2	Configuring Inrush Current.....	581
18.4.3	Inrush Current Settings.....	582
18.5	Current Harmonic.....	584
18.5.1	Current Harmonic Results.....	584
18.5.2	Configuring Current Harmonic.....	586
18.5.3	Current Harmonic Settings.....	587
18.6	Modulation Analysis.....	589
18.6.1	Modulation Analysis Results.....	589
18.6.2	Configuring Modulation Analysis.....	591
18.6.3	Modulation Analysis Settings.....	591
18.7	Dynamic On Resistance.....	593
18.7.1	Dynamic On Resistance Results.....	593
18.7.2	Configuring Dynamic On Resistance.....	594
18.7.3	Dynamic On Resistance Settings.....	595
18.8	Slew Rate.....	597
18.8.1	Slew Rate Results.....	597
18.8.2	Configuring Slew Rate.....	598
18.8.3	Slew Rate Settings.....	599

18.9	Safe Operating Area (S.O.A.)	600
18.9.1	Safe Operating Area Results.....	601
18.9.2	Configuring Safe Operating Area.....	602
18.9.3	Safe Operating Area Settings.....	603
18.10	Turn On/ Off	605
18.10.1	Turn On/ Off Results.....	605
18.10.2	Configuring Turn On/ Off.....	606
18.10.3	Turn On/ Off Settings.....	607
18.11	Switching Loss	610
18.11.1	Switching Loss Results.....	610
18.11.2	Configuring Switching Loss.....	612
18.11.3	Switching Loss Settings.....	613
18.12	Power Efficiency	615
18.12.1	Power Efficiency Results.....	615
18.12.2	Configuring Power Efficiency.....	616
18.12.3	Power Efficiency Settings.....	617
18.13	Output Ripple	618
18.13.1	Output Ripple Results.....	619
18.13.2	Configuring Output Ripple.....	620
18.13.3	Output Ripple Settings.....	621
18.14	Transient Response	623
18.14.1	Transient Response Results.....	623
18.14.2	Configuring Transient Response.....	624
18.14.3	Transient Response Settings.....	625
18.15	Output Spectrum	628
18.15.1	Output Spectrum Results.....	628
18.15.2	Configuring Output Spectrum.....	629
18.15.3	Output Spectrum Settings.....	629
19	USB 2.0 Compliance Test (Option R&S RTO-K21)	631
20	Ethernet Compliance Test (Option R&S RTO-K22)	633
21	Remote Control	634
21.1	Basics	634

21.1.1	Remote Control Interfaces and Protocols.....	634
21.1.2	Starting and Stopping Remote Control.....	636
21.1.3	Messages	637
21.1.4	SCPI Command Structure.....	640
21.1.5	Command Sequence and Synchronization.....	648
21.1.6	Status Reporting System.....	650
21.1.7	General Programming Recommendations.....	663
21.2	Command Reference.....	663
21.2.1	Conventions used in Remote Command Description.....	664
21.2.2	Finding the Appropriate Command.....	664
21.2.3	Frequently Used Parameters and Suffixes.....	665
21.2.4	Common Commands.....	668
21.2.5	General Remote Settings.....	673
21.2.6	Acquisition and Setup.....	675
21.2.7	Trigger.....	701
21.2.8	Display.....	747
21.2.9	Reference Waveforms.....	775
21.2.10	Cursor Measurements.....	782
21.2.11	Automatic Measurements.....	789
21.2.12	Mathematics.....	847
21.2.13	Mask Testing.....	863
21.2.14	Search.....	878
21.2.15	Data Management.....	913
21.2.16	General Instrument Setup.....	934
21.2.17	Protocols.....	938
21.2.18	Mixed Signal Option (MSO, R&S RTO-B1).....	1048
21.2.19	I/Q Software Interface (Option R&S RTO-K11).....	1069
21.2.20	Jitter Measurements and Clock Data Recovery (Options R&S RTO-K12/13).....	1075
21.2.21	Power Analysis (Option R&S RTO-K31).....	1090
21.2.22	Maintenance.....	1122
21.2.23	Status Reporting.....	1122
21.3	Programming Examples.....	1127
21.3.1	Display.....	1127

21.3.2	Automatic Measurements.....	1128
21.3.3	Mask Testing.....	1130
21.3.4	Search.....	1131
21.3.5	Data Management.....	1131
21.3.6	Power Analysis (Option R&S RTO-K31).....	1135
22	Maintenance.....	1139
22.1	Cleaning.....	1139
22.2	Troubleshooting with RTOServiceReporter.....	1140
22.3	Data Security.....	1140
22.4	Storing and Packing.....	1140
22.5	Performing a Selftest.....	1141
22.6	Reference for Maintenance Settings.....	1141
22.6.1	Board Detection/Maintenance.....	1141
22.6.2	Selftest.....	1142
A	Menu Overview.....	1143
A.1	File Menu.....	1143
A.2	Horizontal Menu.....	1144
A.3	Trigger Menu.....	1144
A.4	Vertical Menu.....	1145
A.5	Math Menu.....	1145
A.6	Cursor Menu.....	1145
A.7	Meas Menu.....	1146
A.8	Masks Menu.....	1146
A.9	Search Menu.....	1146
A.10	Analysis Menu.....	1147
A.11	Display Menu.....	1147
	List of Commands.....	1149
	Index.....	1178

1 Preface

1.1 Documentation Overview

The user documentation for the R&S RTO consists of the following parts:

- Online Help system on the instrument
- "Getting Started" printed manual in English
- Documentation CD-ROM with:
 - Getting Started
 - User Manual
 - Service Manual
 - Data sheet and product brochure
 - Links to useful sites on the Rohde & Schwarz internet

Online Help

The Online Help is embedded in the instrument's firmware. It offers quick, context-sensitive access to the complete information needed for operation and programming.

Getting Started

The English edition of this manual is delivered with the instrument in printed form. The manual is available also in other languages in PDF format on the Documentation CD-ROM. It provides the information needed to set up and start working with the instrument, and describes basic operations and typical measurement examples. The manual includes also safety information.

User Manual

The user manual is available in PDF format on the Documentation CD-ROM. This manual describes all instrument functions in detail. It provides an introduction to remote control and a complete description of the remote control commands with programming examples.

Web Help

The web help provides online access to all instructions on how to operate the R&S RTO: No need to download first. Web help content corresponds to the user manual for the latest product version.

The web help is available from the R&S RTO product page at www.scope-of-the-art.com/product/rto.html >"Downloads > Web Help".

Service Manual

The Service Manual is available in PDF format on the Documentation CD-ROM. It describes how to check compliance with rated specifications, instrument function,

repair, troubleshooting, and fault elimination. It contains all information required for repairing the instrument by replacing modules.

Documentation updates

You can download the newest version of the "Getting Started" and "User Manual" from the "Downloads > Manuals" section on the Rohde & Schwarz "Scope of the Art" website: www.scope-of-the-art.com/product/rto.html.

The current online help is part of the instrument firmware, and it is installed together with the firmware. Firmware updates are available in the "Downloads > Firmware" section on the Rohde & Schwarz "Scope of the Art" product website.

1.2 Conventions Used in the Documentation

1.2.1 Typographical Conventions

The following text markers are used throughout this documentation:

Convention	Description
"Graphical user interface elements"	All names of graphical user interface elements on the screen, such as dialog boxes, menus, options, buttons, and softkeys are enclosed by quotation marks.
KEYS	Key names are written in capital letters.
File names, commands, program code	File names, commands, coding samples and screen output are distinguished by their font.
<i>Input</i>	Input to be entered by the user is displayed in italics.
Links	Links that you can click are displayed in blue font.
"References"	References to other parts of the documentation are enclosed by quotation marks.

1.2.2 Conventions for Procedure Descriptions

When describing how to operate the instrument, several alternative methods may be available to perform the same task. In this case, the procedure using the touchscreen is described. Any elements that can be activated by touching can also be clicked using an additionally connected mouse. The alternative procedure using the keys on the instrument or the on-screen keyboard is only described if it deviates from the standard operating procedures.

The term "select" may refer to any of the described methods, i.e. using a finger on the touchscreen, a mouse pointer in the display, or a key on the instrument or on a keyboard.

2 Getting Started

Note: the following chapters are identical to those in the R&S RTO Getting Started manual.

- [Preparing for Use](#)..... 17
- [Instrument Tour](#).....25
- [Trying Out the Instrument](#)..... 39
- [Operating the Instrument](#)..... 70

2.1 Preparing for Use

This section describes the basic steps to be taken when setting up the R&S RTO for the first time.

NOTICE

Risk of instrument damage

Note that the general safety instructions also contain information on operating conditions that will prevent damage to the instrument. The instrument's data sheet may contain additional operating conditions.

2.1.1 Unpacking and Checking the Instrument

To remove the instrument from its packaging and check the equipment for completeness, proceed as follows:

1. Pull off the polyethylene protection pads from the instrument's rear feet and then carefully remove the pads from the instrument handles at the front.
2. Pull off the corrugated cardboard cover that protects the rear of the instrument.
3. Carefully unthread the corrugated cardboard cover at the front that protects the instrument handles and remove it.
4. Check the equipment for completeness using the delivery note and the accessory lists for the various items.
5. Check the instrument for any damage. If there is damage, immediately contact the carrier who delivered the instrument. Make sure not to discard the box and packing material.



Packing material

Retain the original packing material. If the instrument needs to be transported or shipped at a later date, you can use the material to protect the control elements and connectors.

2.1.2 Positioning the Instrument

The instrument is designed for use under laboratory conditions. It can be used in standalone operation on a bench top or can be installed in a rack.

CAUTION

Risk of injury and instrument damage if stacking instruments

A stack of instruments may tilt over and cause injury and material damage because the instrument's top surface area is too small.

Never stack instruments on top of each other. If you need to stack instruments, install them in a rack.



2.1.2.1 Standalone Operation

For standalone operation, place the instrument on a horizontal bench with even, flat surface. The instrument can be used in horizontal position, standing on its feet, or with the support feet on the bottom extended.

⚠ CAUTION**Risk of injury if feet are folded out**

The feet may fold in if they are not folded out completely or if the instrument is shifted. This may cause damage or injury.

- Fold the feet completely in or completely out to ensure stability of the instrument. Never shift the instrument when the feet are folded out.
- When the feet are folded out, do not work under the instrument or place anything underneath.
- The feet can break if they are overloaded. The overall load on the folded-out feet must not exceed 200 N.

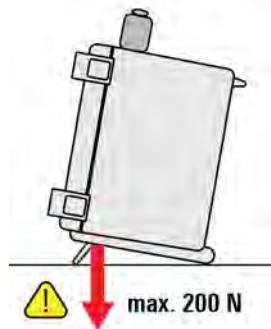
**2.1.2.2 Rackmounting**

The instrument can be installed in a 19" rack mount using a rack adapter kit. The order No. is given in the data sheet. The installation instructions are part of the adapter kit.

NOTICE**Risk of instrument damage in a rack**

An insufficient airflow can cause the instrument to overheat, which may disturb the operation and even cause damage.

Make sure that all fan openings are unobstructed, that the airflow perforations are unimpeded, and that the minimum distance from the wall is 10 cm.

2.1.3 Starting the Instrument

NOTICE

Risk of instrument damage during operation

An unsuitable operating site or test setup can cause damage to the instrument and to connected devices. Ensure the following operating conditions before you switch on the instrument:

- All fan openings are unobstructed and the airflow perforations are unimpeded. The minimum distance from the wall is 10 cm.
- The instrument is dry and shows no sign of condensation.
- The instrument is positioned as described in the following sections.
- The ambient temperature does not exceed the range specified in the data sheet.
- Signal levels at the input connectors are all within the specified ranges.
- Signal outputs are correctly connected and are not overloaded.

2.1.3.1 Powering On

The R&S RTO can be used with different AC power voltages and adapts itself automatically to it. The nominal voltage and frequencies ranges are displayed on the rear panel and quoted in the data sheet.

⚠ WARNING

Risk of injury and instrument damage

The instrument must be used in an appropriate manner to prevent electric shock, fire, personal injury, or damage.

- Do not use an isolating transformer to connect the instrument to the AC power supply.
- Do not open the instrument casing.
- Read and observe the "Basic Safety Instructions" at the beginning of this manual or on the documentation CD-ROM, in addition to the safety instructions in the following sections. Notice that the data sheet may specify additional operating conditions.

The AC power connector and the main power switch are located on the rear panel of the instrument.

1. Connect the instrument to the AC power supply using the AC power cable delivered with the instrument.
2. Switch the main power switch at the rear of the instrument to position I.



You can leave on the AC power permanently. Powering off is only required if the instrument must be completely disconnected from all power supplies.

2.1.3.2 Starting Up and Shutting Down

The POWER switch is located in the bottom left corner of the front panel.

To start up the instrument

1. Make sure that the R&S RTO is connected to the AC power supply and the main power switch on the rear panel is in position I.
2. Press the POWER key on the front panel.

The instrument performs a system check, boots the Windows operating system, and then starts the R&S RTO firmware. The illuminated keys on the front panel light up. If the previous session was terminated regularly, the oscilloscope uses the last settings.

To shut down the instrument

- ▶ Press the POWER key again.
Alternatively, tap "Exit" on the "File" menu.

All current settings are saved, and the software shuts down. The standby power only supplies the power switch circuits and the optional oven quartz (OCXO, option R&S RTO-B4).

2.1.3.3 Powering Off

Powering off is required only if the instrument must be completely disconnected from all power supplies.

It also interrupts the power supply of the OCXO (option OCXO Reference Frequency, R&S RTO-B4).

When you power on the instrument again, be sure to comply with the extended warm-up phase specified in the data sheet.

1. Press the POWER key on the front panel to shut down the instrument.
2. Switch the main power switch at the rear of the instrument to position 0.
3. Disconnect the AC power cable from the AC power supply.

NOTICE**Risk of losing data**

If you switch off the running instrument using the rear panel switch or by disconnecting the power cord, the instrument loses its current settings. Furthermore, program data may be lost.

Always press the POWER key first to shut down the application properly.

2.1.3.4 EMI Suppression

Electromagnetic interference (EMI) may affect the measurement results.

To suppress generated Electromagnetic Interference (EMI),

- Use suitable shielded cables of high quality. For example use double-shielded RF and LAN cables.
- Always terminate open cable ends.
- Note the EMC classification in the data sheet

2.1.4 Connecting External Devices

The following interfaces for external devices are provided:

- USB connectors, see also "USB" on page 37
- Monitor connector, see also "MONITOR (DVI-D)" on page 38

2.1.4.1 Connecting USB Devices

The USB interfaces on the front and rear panels of the R&S RTO allow you to connect USB devices directly to the instrument. This number can be increased as necessary by using USB hubs. Due to the large number of available USB devices, there is almost no limit to the expansions that are possible with the R&S RTO.

The following list shows various USB devices that can be useful:

- Flash drive for easy transfer of data to/from a computer (e.g. firmware updates)
- CD-ROM drives for easy installation of firmware applications
- Keyboard and/or mouse to simplify the operation and the entry of data, comments, file names, etc.
- Printer for printing out measurement results

All USB devices can be connected to or disconnected from the instrument during operation.

Installing USB devices on R&S RTO is easy under the Windows operating system, because all USB devices are plug&play. After a device is connected to the USB interface, Windows automatically searches for a suitable device driver.

If the operating system does not find a suitable driver, it prompts you to specify a directory that contains the driver software. If the driver software is on a CD, connect a USB CD-ROM drive to the instrument before proceeding.

When a USB device is disconnected from the R&S RTO, Windows immediately detects the change in hardware configuration and deactivates the corresponding driver.

The properties of external USB devices are configured in the operating system, not in the R&S RTO software. It is recommended that you use mouse and keyboard to access and modify the settings of the Windows operating system. To access Windows, press the Windows key on the external keyboard, or select "File > Minimize" on the R&S RTO menu.

Connecting a USB flash drive or CD-ROM drive

If installation of a USB flash driver or CD-ROM drive is successful, Windows informs you that the device is ready to use. The device is made available as a new drive ("D:") and is displayed under Windows Explorer. The name of the drive depends on the manufacturer.

Connecting a keyboard

The keyboard is detected automatically when it is connected. The default input language is English – US.

Windows 7:

Use the Windows' "Start" menu > "Control Panel > Change keyboards or other input methods" to configure the keyboard properties.

Windows XP:

Use the Windows' "Start" menu > "Control Panel > Keyboard" or "Regional and Language Options" to configure the keyboard properties.

Connecting a mouse

The mouse is detected automatically when it is connected.

Windows 7:

Use the Windows' "Start" menu > "Devices and Printers > Mouse" to configure the mouse properties.

Windows XP:

Use the Windows' "Start" menu > "Control Panel > Mouse" to configure the mouse properties.

Connecting a printer

When printing a file, the instrument checks whether a printer is connected and turned on and whether the appropriate printer driver is installed. If necessary, printer driver installation is initiated using the Windows' "Add a Printer" wizard. A printer driver needs to be installed only once.

You can load updated and improved driver versions or new drivers from an installation disk, USB flash drive, or another external storage medium. If the instrument is integrated in a network, you can also install driver data stored in a network directory.

Windows 7:

Use the Windows' "Start" menu > "Devices and Printers > Add a printer" to install the driver.

Windows XP:

Use the "Add Printer" wizard on the "Start > Settings > Printer and Faxes" menu to install the driver.

2.1.4.2 Connecting an External Monitor

You can connect an external monitor or projector to the DVI-D connector on the instrument's rear panel. See also: "[MONITOR \(DVI-D\)](#)" on page 38.

Check the input type of the monitor or projector and make sure to select the correct cable. To use a VGA monitor, an active DVI-D to VGA adapter is required.

After connecting an additional monitor or projector to the instrument, configure the it for usage. The relevant settings are Windows settings. It is recommended that you use a mouse and shut down the firmware for this setup.

1. Shut down the R&S RTO firmware:
On the "File" menu of the R&S RTO application, select "Exit".
2. Right-click the desktop and select "Graphics Options > Output to" on the context menu.
3. To show the instrument's display content only on the external monitor, select "Digital Display".
To show the instrument's display content on both the oscilloscope and the external monitor, select "Clone Displays > Build-in Display + Digital Display".



Tip: Alternatively, you can configure the monitor this way: Right-click the desktop > "Graphics Properties" > "Multiple Displays" > "Operating Mode = Clone Displays"; or "Operating Mode = Single Display" and "Primary Display = Digital Display".

4. Restart the R&S RTO firmware.

The touchscreen of the R&S RTO has a screen resolution of 1278x768 pixel. Most external monitors have a higher screen resolution. If the screen resolution of the monitor is set higher than the instrument's resolution, the application window uses a

1278x768 area of the monitor display. For full screen display, adjust the monitor's screen resolution.

2.2 Instrument Tour

This chapter describes the front and rear panels of the instrument including all function keys and connectors, and also the touchscreen with its control elements.

2.2.1 Front Panel

The front panel of the R&S RTO is shown in [figure 2-1](#). The function keys are grouped in functional blocks to the left and the right of the touchscreen. Below, various connectors are located.



Fig. 2-1: Front panel of R&S RTO1024 with 4 input channels

- 1 = Touchscreen
- 2 = SETUP controls
- 3 = HORIZONTAL controls
- 4 = TRIGGER controls
- 5 = ANALYZE controls
- 6 = VERTICAL controls
- 7 = NAVIGATION controls

- 8 = POWER key
- 9 = Connectors for USB and probe compensation
- 10 = Input channels

NOTICE

Instrument damage caused by cleaning agents

Cleaning agents contain substances that may damage the instrument, for example cleaning agents that contain a solvent may damage the front panel labeling, plastic parts, or the display.

Never use cleaning agents such as solvents (thinners, acetone, etc), acids, bases, or other substances.

The outside of the instrument can be cleaned sufficiently using a soft, lint-free dust cloth.

2.2.1.1 Touchscreen Display

The touchscreen shows not only the captured waveforms, it also provides everything you need to control the instrument, to analyze waveforms, and to get measurement results. Figure 2-2 shows the touchscreen display on a glance.



Fig. 2-2: Touchscreen display

- 1 = Toolbar
- 2 = Diagram area
- 3 = Signal bar with horizontal and trigger label (3a), signal icon with signal label (3b) and signal icon with minimized live waveform (3c)
- 4 = Menu bar

- 5 = Dialog box
- 6 = Result box
- 7 = Input box

Toolbar

The icons on the toolbar provide quick and easy access to the most important functionality. For a detailed description, refer to [chapter 2.4.3, "Using the Toolbar"](#), on page 74.

Diagram area

The diagram area shows the diagrams with waveforms. For a detailed description, refer to [chapter 2.4.2, "Information on the Display"](#), on page 72.

Signal bar

The signal bar is the control center for all enabled waveforms. On the top, the horizontal and trigger labels show the main time base and trigger settings.

Below, each waveform is represented by a signal icon. For an active waveform, that is shown in a diagram, the signal icon displays the signal label with the main vertical and acquisition settings for the waveform. If you tap the "Minimize" icon on the signal label, the waveform switches from the diagram area to the signal icon: the icon shows the real-time preview of the waveform. If you touch and hold a signal label, the dialog box with vertical settings for this waveform opens. See [chapter 2.4.4, "Working with Waveforms"](#), on page 77 for a detailed description.

You can also adjust the behavior of the signal bar in various ways, see [chapter 2.4.6, "Using the Signal bar"](#), on page 81.

Menu bar

The menus provide access to the complete functionality of R&S RTO.

Dialog box

The tabs of the dialog boxes contain all task-oriented settings and operations, and black buttons for calling related tabs. The usage of dialog boxes is described in [chapter 2.4.7, "Accessing the Functionality"](#), on page 83.

Result box

If you perform manual or automatic measurements, mask testing, or a search, the result box shows the results of the action. Similar to waveform diagrams, you can minimize the result box to a result icon on the signal bar, and display results in a separate diagram on the screen. The  icon opens the corresponding dialog box to adjust the settings.

For details, see [chapter 2.4.5, "Displaying Results"](#), on page 80.

Input box

The input box appears if you adjust a value using one of the rotary knobs, or if you drag an element on the screen, for example, a cursor line. The input box shows the current value of the modified parameter. You can enter the exact numerical value, change the step size, and - if available - autoset the value directly in the input box. The box title shows the name of the currently adjusted parameter. The input box is helpful when using the multi-function rotary knobs - POSITION knobs, INTENSITY, and RESOLUTION/RECORD LENGTH.



See also: [chapter 2.4.8, "Entering Data"](#), on page 84.

2.2.1.2 SETUP Controls

SETUP keys set the instrument to a defined state, change basic settings, and provide print and help functions. The intensity rotary knob adjusts the display contrast for several display elements.

AUTOSET

The instrument analyzes the enabled channel signals, and adjusts appropriate horizontal, vertical, and trigger settings to display stable waveforms.

PRESET

Resets the instrument to a default state. All measurements, mask tests, zoom, and most individual settings are deleted, all channels except for channel 1 are disabled. You can define preset configurations and save them to a file. The PRESET key can be configured to set either factory defaults or a user-defined preset configuration.

FILE

Opens and closes the "File" dialog box, where you can:

- Save settings
- Load settings which were saved before
- Manage the data: browse, copy, delete, create folders
- Define a naming pattern for waveform data files

SETUP

Opens and closes the "Setup" dialog box, where you can:

- Access MS Windows configuration and install firmware updates
- Configure the touchscreen
- Check and install option keys for software options
- Check availability of hardware options
- Configure LXI and GPIB (if installed)

PRINT

Configures and starts the printing.

HELP

Opens the appropriate help topic for the active tab. If no dialog box is open, the contents page of the online help appears.

MODE

Opens and closes a dialog box where you can enable functionality in beta state. If option R&S RTO-K11 is installed, you can also change to the I/Q mode of the instrument.

T-SCREEN LOCK

Locks the touchscreen to prevent unintended use. When the touchscreen is off, the key is illuminated. Press again to unlock the touchscreen.

DISPLAY

Opens and closes the "Display" dialog box to configure the appearance of the waveforms, the diagram layout, color tables, and also the XY-diagram.

INTENSITY

Adjusts the intensity of the waveforms on the screen, or the background transparency of dialog boxes, or the transparency of result boxes. If a dialog box is open, turning the knob changes the transparency of dialog boxes. If a result box is open, the transparency of result boxes is changed. Otherwise the waveform intensity is adjusted. Press the knob to toggle between the three settings. The controlled parameter and its value are shown in the input box in the upper left corner of the screen.

2.2.1.3 HORIZONTAL Controls

The keys and rotary knobs in the HORIZONTAL functional block adjust the acquisition basic settings and the horizontal parameters. These settings are effective for all channel waveforms.

**RES / REC LEN**

Opens and closes the "Resolution" tab in the "Horizontal" dialog box, where you can set the resolution and the record length.

HORIZONTAL

Opens and closes the "Time Base" tab in the "Horizontal" dialog box, where you can:

- Adjust the time scale, acquisition time, horizontal position, and reference point
- Enable the roll mode

ACQUISITION

Opens and closes the "Acquisition" tab in the "Horizontal" dialog box, where you can:

- Configure up to three waveforms per channel
- Define the acquisition processing

RESOLUTION / RECORD LENGTH

The rotary knob changes the resolution or the record length. Press the knob to toggle the setting. The controlled parameter and its value are shown in the input box in the upper left corner of the screen.

For resolution, turn clockwise to increase the resolution: the time between two acquisition points gets shorter; and record length and sample rate increase while the acquisition time remains constant.

For record length, turn clockwise to increase the record length, and the resolution increases - the time between to acquisition points gets shorter.

POSITION / REF POINT

The rotary knob changes the horizontal position of the waveform or the screen position of the reference point. Press the knob to toggle the setting. The controlled parameter and its value are shown in the input box in the upper left corner of the screen.

The reference point marks the rescaling center of the time scale. It is indicated by a gray triangle outline at the top of the diagram. If you modify the time scale, the reference point remains fixed on the screen, and the scale is stretched or compressed to both sides of the reference point.

"Horizontal position" defines the time distance of the reference point from the zero point of the diagram. Turn clockwise to move the waveform to the right.

"Reference point" defines the position of the reference point on the screen. Turn clockwise to move it to the right.

SCALE

The rotary knob adjusts the time scale for all signals. The time scale is also known as time base.

Turn clockwise to stretch the waveforms. Doing so, the scale value *time/div* decreases.

2.2.1.4 TRIGGER Controls

The keys and knob in the TRIGGER functional block adjust the trigger and start or stop acquisition.

**TRIGGER**

Opens and closes the "Trigger" dialog box, where you can:

- Select a trigger type and configure it

- Set general trigger parameters and control the acquisition run
- Qualify the trigger event with logic patterns
- Configure a sequence of three trigger events

LEVEL

The rotary knob sets the trigger level for all trigger types. Turn clockwise to move the trigger level up. If the selected trigger type requires two trigger levels - upper and lower level - press the knob to toggle between the two levels.

SOURCE

Opens a dialog box where you can select the trigger source. Press the key again to switch the source. The key lights up in the color of the selected trigger source.

SLOPE

Toggles the trigger slope or trigger polarity, dependent on the trigger type. The current setting is shown on the trigger label, which is the upper part of the signal bar on the touchscreen.

MODE

Toggles the trigger mode between Auto and Normal. The current setting is shown on the trigger label.

RUN CONT

Starts and stops the continuous acquisition. A green light indicates a running acquisition. A red light shows that acquisition is stopped.

RUN N× SINGLE

Starts a defined number of acquisition cycles. A green light indicates running acquisition. A red light shows that acquisition is stopped. To set the number of acquisitions, press the TRIGGER key, select the "Control" tab, and set "Average count (N-single count)". Press the key again to stop running acquisitions.

2.2.1.5 VERTICAL Controls

The keys and knobs in the VERTICAL functional block select a signal and adjust the vertical scale and position of the parameters of the selected signal.



CH <N>

Turns on, selects, and configures a channel. The key is illuminated with the corresponding channel color, if the channel is active.

The effect of the keypress depends on state of the channel:

- If channel is off: Pressing the key turns on the channel and selects it.
- If the channel is on, but not selected: Pressing the key selects the channel waveform.
- If the waveform is selected: Pressing the key opens the "Vertical" dialog box for the appropriate channel.

The vertical rotary knobs are focused on the selected waveform and they are illuminated in the color of the selected waveform.

REF

Opens the "Reference" dialog box, where you can configure and display reference waveforms. Press the button repeatedly to switch to the reference waveform to be configured.

The vertical rotary knobs are focused on the selected reference waveform and they are illuminated in the color of the selected waveform.

MATH

Opens the "Math" dialog box, where you can configure the calculation of new waveforms with various mathematic operations from other waveforms. Press the button repeatedly to switch to the math waveform to be configured.

The vertical rotary knobs are focused on the selected math waveform and they are illuminated in the color of the selected waveform.

POSITION / OFFSET

The rotary knob changes the vertical position or the offset of the selected waveform. The horizontal axis and the selected waveform are moved vertically. Press the knob to toggle the setting, and turn clockwise to move the waveform up. The controlled parameter and its value are shown in the input box in the upper left corner of the screen.

- Position indicates the vertical location in divisions.
- Offset moves the vertical center of the selected channel to the offset value.

The knob lights up in the color of the selected waveform.

SCALE

This rotary knob adjusts the vertical scale for the selected waveform. The knob lights up in the color of the selected waveform.

Turn clockwise to stretch the waveform. Doing so, the scale value V/div decreases.

SIGNAL OFF

Turns off the selected signal and selects the next channel, math, or reference waveform.

The key is illuminated in the color of the selected signal and changes the color according to the new selection.

2.2.1.6 ANALYZE Keys

The keys in the ANALYZE functional block provide direct access to measurement and analyzing functions. For CURSOR, ZOOM and MEAS, the operation is started on first keypress, and a second keypress opens the corresponding dialog box. For all other functions, pressing the key opens the dialog box.



CURSOR

Displays vertical and horizontal cursors in the active diagram and displays the "Cursor Results" box.

Cursors are markers which are placed at points of interest on a waveform. The instrument measures the cursor positions and delta values between parallel cursors.

If you press the key while a cursor measurement is enabled, the "Cursors" dialog box is opened.

In "Cursors" dialog box, you can:

- Configure up to four cursor sets
- Define style and labels of the cursors
- Connect the cursor to the waveform and couple the cursors

MEAS

Starts the default automatic measurement for the active waveform and displays the "Measurement" result box.

If you press the MEAS key while a measurement is enabled, the "Measurements" dialog box is displayed, where you can:

- Configure amplitude and time measurements, eye, spectrum, and histogram measurements
- Configure gated measurement
- Configure long term and statistic measurements
- Configure actions to be executed if specified limits are exceeded

MASKS

Opens and closes the "Masks" dialog box. Masks are used for error detection and compliance tests of digital signals.

You can:

- Configure masks and masks segments
- Define mask test parameters
- Configure actions triggered by mask violation
- Configure the mask display

SEARCH

Opens and closes the "Search" dialog box, where you can:

- Configure trigger or measurement events to be searched for
- Limit the search by gating

- Configure the presentation of search results

ZOOM

Displays a zoom diagram for the active diagram. If you press the key while the zoom function is on, the "Zoom" dialog box opens, where you can configure several zoom areas for detailed signal observation.

PROTOCOL

The key is only relevant, if at least one of the options RTO-K1 to RTO-K4 is installed. The "Protocol" dialog box contains the configuration of serial buses and the settings for decoding the signals.

USER

Intended for future applications.

HISTORY

The sample memory contains a number of stored acquisitions before the current one which is shown in the display. Press the button to open the quick access "History" dialog box, where you can view the stored acquisitions and use them for further analysis. Press the button again to open the main "History" dialog box with more settings and information.

The button is illuminated as long as a history acquisition or replay is displayed.

2.2.1.7 NAVIGATION Controls

The rotary knob and the navigation keys provide an alternative way to navigate in dialog boxes and to enter numeric data.



See also: [chapter 2.4.7, "Accessing the Functionality"](#), on page 83

Navigation rotary knob

The navigation knob has various functions:

- In numeric entry fields: turn clockwise to increase the value.
- In tables: press to activate the edit mode, turn clockwise to increase the value or turn counter-clockwise to decrease it, and press to enter the value and move to the next line.

- In input boxes to set cursor positions, histogram areas, mask points: press to toggle the parameter, turn clockwise to increase the value or turn counter-clockwise to decrease it.

UNDO

Reverses the last setting actions step by step. The "Undo" is not possible after Preset, load and recall actions, and creating a reference waveform.

REDO

Recovers the undo steps in reverse order.

ESC

Closes a dialog box or input box.

ENTER

The ENTER key has various functions:

- In usual dialog box: if the focus is on a selection list, the key opens the list and applies the selected value.
- In tables: the key activates the edit mode. If the table cell is in edit mode, the key confirms the value, quits the edit mode and moves to the next line.

FIELD LEFT, FIELD RIGHT

In dialog boxes and tables, the keys move the focus.

CHECKMARK

The CHECKMARK key has different functions depending on the focus:

- In usual dialog box: if the focus is on a selection list, the key opens the list and applies the selected value.
- In tables: activates the edit mode.

TAB

In a dialog box with horizontal tabs only, the key switches the horizontal tabs.

In a dialog box with horizontal and vertical tabs, the key switches the vertical tabs preferably. If the focus is on a horizontal tab, it switches the horizontal tabs.

In a table, the key moves the focus in the same way as the FIELD RIGHT key.

UP ARROW, DOWN ARROW

- In numeric edit fields: increase or decrease the parameter value.
- In tables: scroll vertically through the rows.
- In dialog boxes, for option buttons in a column: select an option. In an open selection list, the keys scroll the list.

LEFT ARROW, RIGHT ARROW

- In edit fields: move the cursor.
- In tables: scroll horizontally through the columns.
- In dialog boxes, for option buttons in a row: select an option.

2.2.1.8 POWER key

The POWER key is located on the lower left corner of the front panel. It starts up and shuts down the instrument.

See also: [chapter 2.1.3, "Starting the Instrument"](#), on page 20.

2.2.1.9 Input Connectors

The R&S RTO has two or four channel inputs to connect the input signals using active and passive probes.

The connectors are provided with a special Rohde & Schwarz active probe interface, and they are BNC compatible. Thus, the instrument can automatically detect passive probes with standard BNC connector and active Rohde & Schwarz probes having the Rohde & Schwarz probe interface.

The input impedance is selectable, the values are 50 Ω and 1 M Ω .

CAUTION

Risk of injury

If the input voltages are higher than 30 V RMS or 42 V peak or 60 V DC, use appropriate protective measures to preclude direct contact with the measurement setup.

CAUTION

Risk of injury and instrument damage

The instrument complies with measuring category I; make sure that the input voltage does not exceed 200 V peak, 150 V RMS at 1 M Ω input impedance and 5 V RMS at 50 Ω input impedance.

Transient overvoltages must not exceed 200 V peak.

When performing measurements in circuits with transient overvoltages higher than category I, make sure that no such overvoltages reach the R&S RTO input. Therefore, use only probes that comply with DIN EN 61010-031. When performing measurements in category II, III or IV circuits, it is mandatory to insert a probe that appropriately reduces the voltage so that no overvoltages higher than category I are applied to the instrument. For detailed information, refer to the documentation and safety information of the probe manufacturer.

Explanation: According to section 6.7.4 of EN 61010-1, measuring category I is intended for measurements on circuits which are not connected to the mains system.

2.2.1.10 Other Front Panel Connectors

Besides the input connectors, the instrument has USB connectors and probe compensation connectors at the front panel.



USB

Two USB type A connectors that comply with standard USB 2.0. They are used to connect devices like keyboard, mouse, printer and flash device to store and reload instrument settings and measurement data. Also environment sensors can be connected to measure and display temperature and other environment conditions.

Note: Electromagnetic interference (EMI) can affect the measurement results. To avoid any impact, do not use USB connecting cables exceeding 1 m in length.

PROBE COMPENSATION

Probe compensation terminal to support adjustment of passive probes to the oscilloscope channel.

	Protective earth conductor for grounding the instrument.
	Square wave signal for probe compensation with 1 kHz and 1 V _{pp} .
	Ground connector for probes.

AUX OUT

Output of the internal calibration signal, if the signal is configured to external destination.

2.2.2 Rear Panel

Figure 2-3 shows the rear panel of the R&S RTO with its connectors.



Fig. 2-3: Rear panel view of R&S RTO

- 1 = AC power supply connector and main power switch
- 2 = LAN connector
- 3 = USB connectors
- 4 = DVI-D connector for external monitor
- 5 = External trigger input
- 6 = External trigger output
- 7a = Optional GPIB connector (option R&S RTO-B10, shown in figure)
- 7b = Optional connector for digital probe, Mixed Signal Option (option R&S RTO-B1, not shown in figure)
- 8 = Optional OCXO with input and output of the reference signal (option R&S RTOR&S RTO-B4)
- 9 = Optional exchangeable hard disk (option R&S RTO-B19)
- 10 = Lugs to attach the accessory bag
- 11 = Kensington lock slot to secure the instrument against theft

AC power supply connector and main power switch

The AC main power switch disconnects the instrument from the AC power line. It also interrupts the power supply of the OCXO (option OCXO Reference Frequency, R&S RTO-B4).

When you power on the instrument again, be sure to comply with the extended warm-up phase specified in the data sheet.

LAN

8-pin RJ-45 connector used to connect the instrument to a Local Area Network (LAN). It supports up to 1000 Mbit/s (10/100/1000BASE-T Ethernet).

USB

Two USB type A connectors that comply with standard USB 2.0. They are used to connect devices like keyboard, mouse, printer and flash drive to store and reload instrument settings and measurement data. Also environment sensors can be connected to measure and display temperature and other environment conditions.

Note: Electromagnetic interference (EMI) can affect the measurement results. To avoid any impact, do not use USB connecting cables exceeding 1 m in length.

MONITOR (DVI-D)

Digital connector for an external monitor or projector. The monitor shows the complete content of the instrument's screen.

See also: [chapter 2.1.4.2, "Connecting an External Monitor"](#), on page 24.

EXT TRIGGER INPUT

The BNC connector for external trigger input is used to control the measurement by means of an external signal. The input impedance can be selected in the trigger configuration, the values are 50 Ω and 1 M Ω . The trigger level can be set from -6.9 V to 6.9 V. The maximum input voltage is 30 V RMS at 1 M Ω input impedance and 7 V RMS at 50 Ω input impedance.

EXT TRIGGER OUTPUT

The BNC connector for external trigger output is used to provide the internal trigger signal of the oscilloscope to trigger other instruments for synchronized measurements. When a trigger occurs, the R&S RTO creates a pulse of 5 V with a source impedance of 50 Ω and delivers it to the external trigger output. The instrument can also send the pulse on mask test violation or violation of measurement limits and margins.

If the connector is terminated with 50 Ω , the signal level is 2.5 V (50 mA), and with 1 M Ω termination the level is 5 V. A short-circuit of the connector to ground creates current of 100 mA.

To enable the trigger out signal, select "Trigger" menu > "Trigger Control". Here you also adjust polarity, delay, and length of the pulse. The default is a positive pulse of 10 ns. The minimum delay is 800 ns.

REF IN/OUT

BNC female connector for input or output of reference signals. The input or output direction is set in the software.

The input frequency ranges from 1 MHz to 20 MHz in 1 MHz steps. The input impedance is 50 Ω .

The output frequency is from 10 MHz, the impedance is 50 Ω . For detailed specifications refer to the Data Sheet.

RTO-B1 (MSO)

Mixed Signal Option, input for digital signals (parallel buses). The hardware module and digital probe come with option R&S RTO-B1. The module provides connectors for two logical probes with 8 digital channels each (D0 to D7 and D8 to D15).

The maximum input voltage is 40 V peak at 100 k Ω input impedance. The maximum input frequency for a signal with the minimum input voltage swing of 500 mV (V_{pp}) is 400 MHz. For detailed specifications refer to the Data Sheet.

RTO-B10 (GBIP)

Optional GBIP connector coming with option R&S RTO-B10 GBIP Interface. For detailed specifications refer to the Data Sheet.

RTO-B4 (OCXO)

Optional REF IN (left) and REF OUT (right) connectors coming with option R&S RTOB4 OCXO 10 MHz.

2.3 Trying Out the Instrument

This chapter introduces the most important functions and settings of the R&S RTO step by step. The complete description of the functionality and its usage is given in the "User Manual". Basic instrument operation is described in [chapter 2.4, "Operating the Instrument"](#), on page 70.

Prerequisites

- The instrument is set up, connected to the mains system, and started up as described in [chapter 2.1, "Preparing for Use"](#), on page 17.
- A probe is available.

For these first measurements, you use the internal calibration signal, so you do not need any additional signal source or instruments. Try out the following:

• Displaying a Basic Signal	40
• Acquiring Data	42
• Organizing the Display	43
• Changing the Waveform Scaling and Position	47
• Zooming into the Display	50
• Displaying the Waveform History	51
• Showing Basic Measurement Results	53
• Performing an FFT Analysis	58
• Performing Mathematical Calculations	61
• Performing a Search	62
• Performing a Mask Test	64
• Printing and Saving Screenshots	67
• Saving Data	68

2.3.1 Displaying a Basic Signal

Displaying the input from a signal channel is very simple and straightforward. Furthermore, you get to know some basic trigger functions. The R&S RTO provides wide-ranging trigger functions to find various signal anomalies, which are described in the "User Manual".

1. Press the PRESET key on the front panel (in the SETUP area on the left).
2. Connect the probe to the input connector CH 1.
Connect the probe's ground connector to the right compensation pin, and the tip with the left pin.

The instrument recognizes the probe, and a signal is displayed in the diagram.

3. Press the AUTOSET key on the front panel (in the SETUP area on the left).
Autoset finds appropriate horizontal and vertical scales and trigger conditions to present a stable square waveform. The trigger is set to edge trigger on rising edge with auto trigger mode.

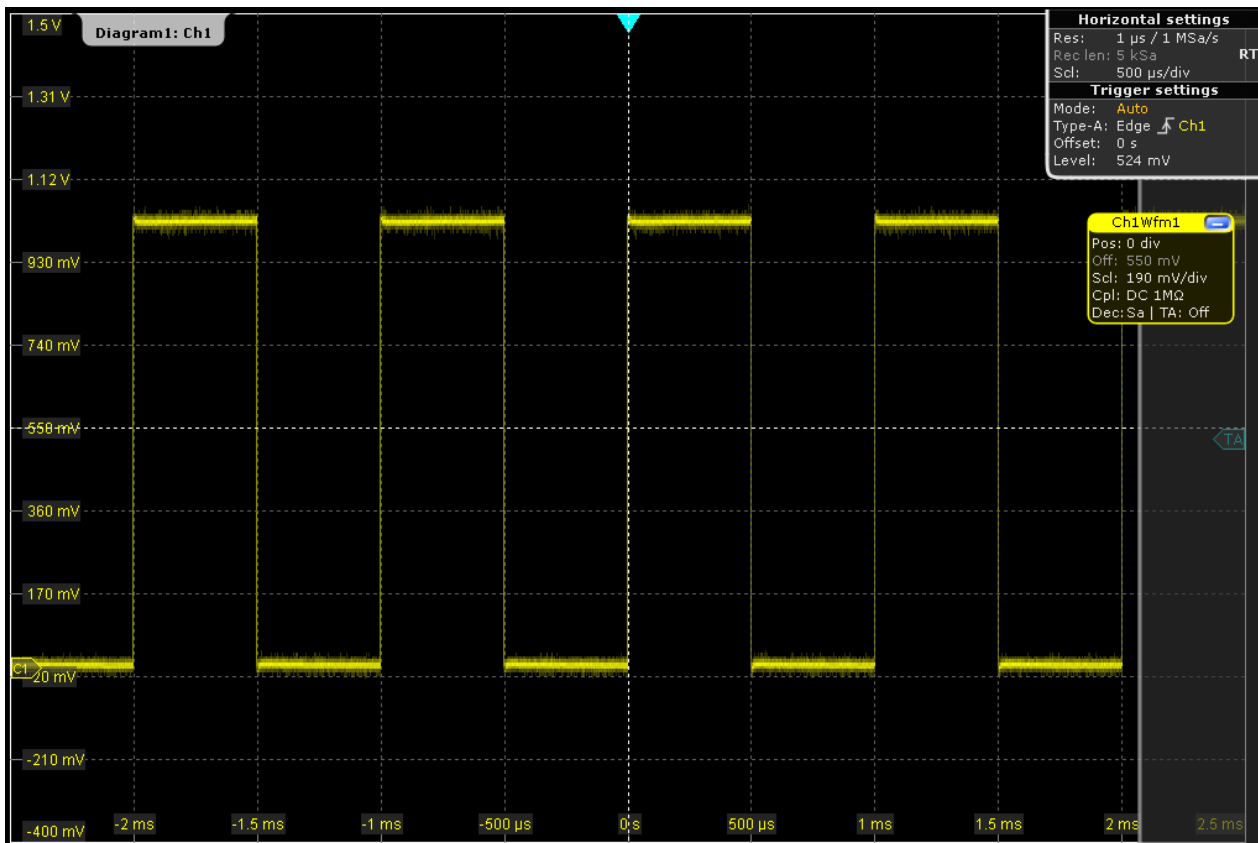

4. If necessary, compensate the passive probe as described in [chapter 12.1.3, "Adjusting Passive Probes"](#), on page 392.
5. Press the SOURCE key in the TRIGGER area of the front panel and press the key again to switch the trigger source to CH2.
An unstable waveform is displayed. In auto mode, the instrument triggers repeatedly after a time interval if no real trigger occurs.
6. Press the MODE key in the TRIGGER area and check the "Trigger settings" in the upper right corner of the screen.
The trigger mode has changed to *Normal*. The waveform is no longer refreshed, and the "Wait for trigger" message box appears. The instrument cannot find a real trigger event because there is no signal on CH2.
7. Tap the "Undo" icon on the toolbar repeatedly until the trigger mode is reset to *Auto* and the trigger source is reset to CH1.
8. Press the SLOPE key to toggle the trigger slope and watch the waveform and the "Trigger settings" label.

2.3.2 Acquiring Data

Although you are using only one input channel, you can acquire the calibration data using three different arithmetic methods and display the results in separate waveforms.

1. Press the ACQUISITION key on the front panel (in the HORIZONTAL area).
2. In the "Acquisition" tab of the "Horizontal" dialog box, enable all three waveforms ("Wfm1", "Wfm2", "Wfm3").
3. For Wfm1, select the "Decimation" type *Sample* and the "Wfm Arithmetic" *Off*.
4. For Wfm2, select the "Wfm Arithmetic" *Envelope*. The "Decimation" type is automatically set to *Peak detect* to display the correct envelope waveform.
5. For Wfm3, select the "Decimation" type *High Res* and the "Wfm Arithmetic" *Average*.

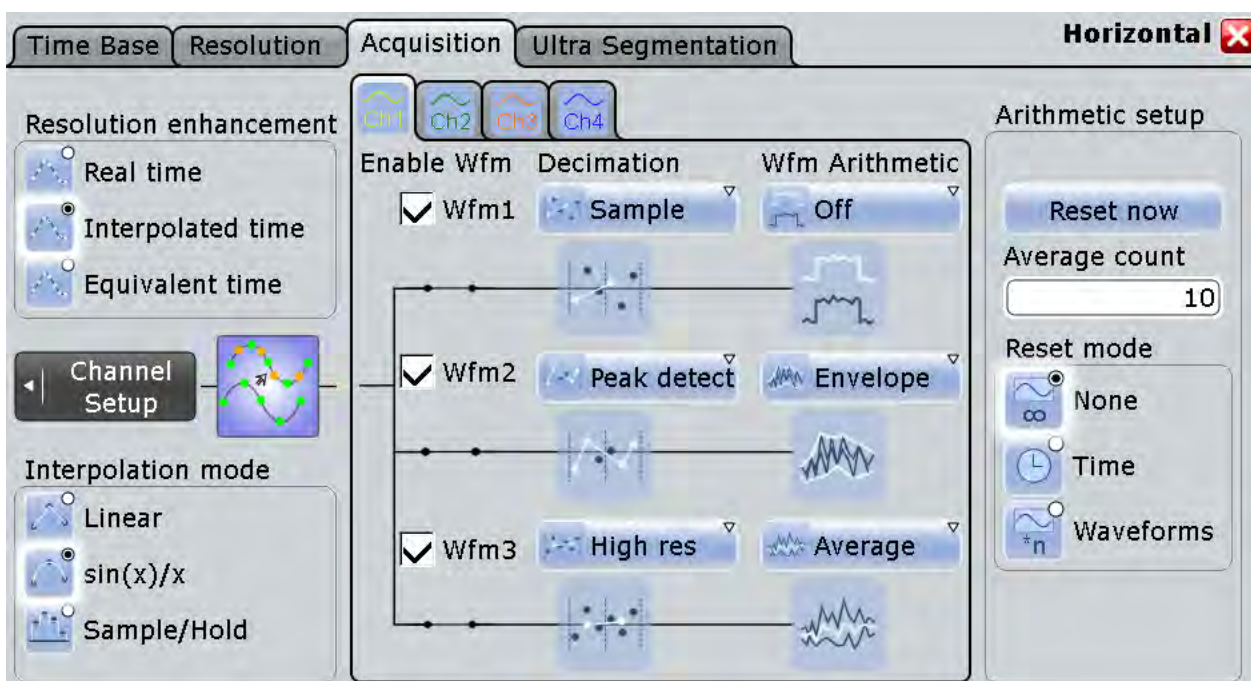

6. Close the "Horizontal" dialog box.

The three waveforms are displayed in one diagram. The corresponding signal icons are displayed in the signal bar.

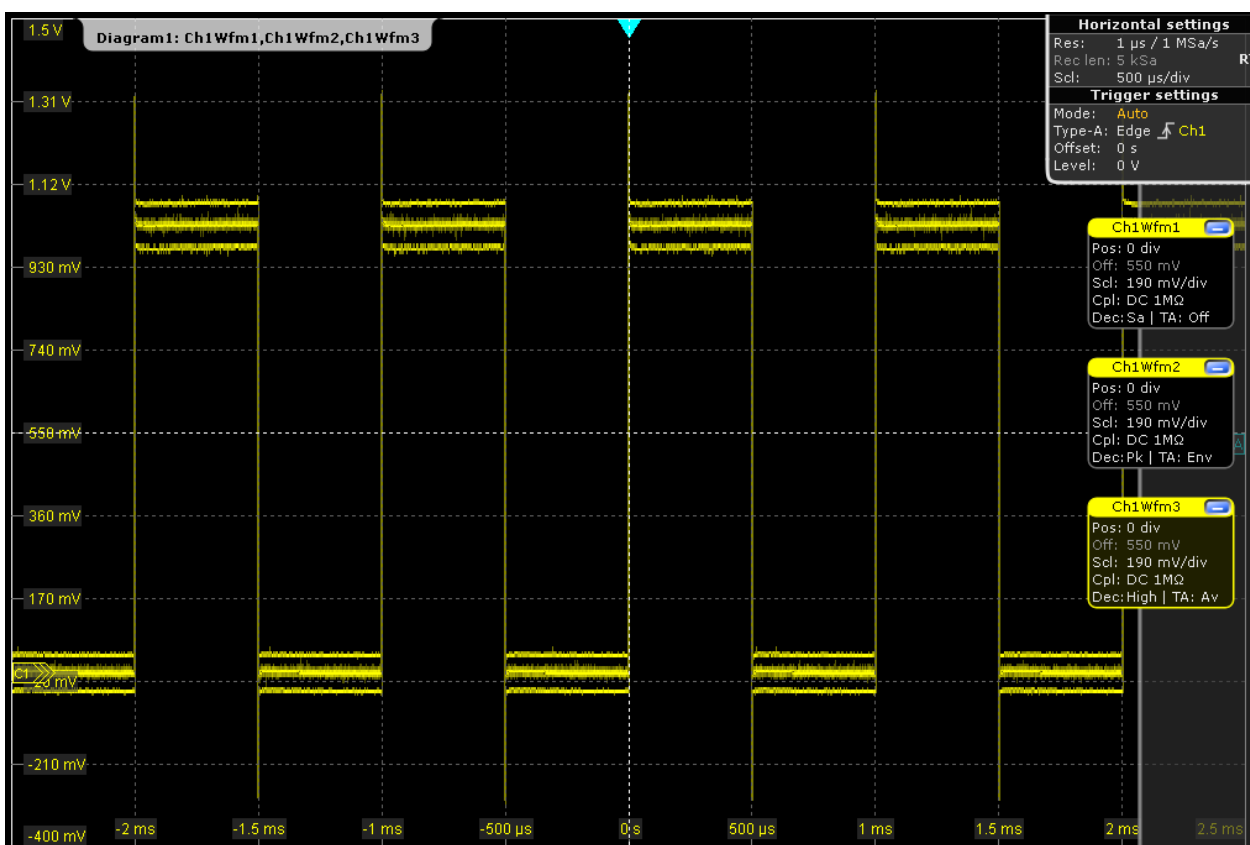

2.3.3 Organizing the Display

Meanwhile, the display has become very confusing with so many waveforms in one diagram. You can display each waveform in a separate diagram and then define a useful label for each diagram. You can also hide diagrams you do not currently need, and display them again later.

To manage several diagrams

1. Drag the signal icon for "Ch1Wfm2" from the signal bar to the bottom half of the diagram area.

The SmartGrid appears and a blue area shows where the waveform will be placed.

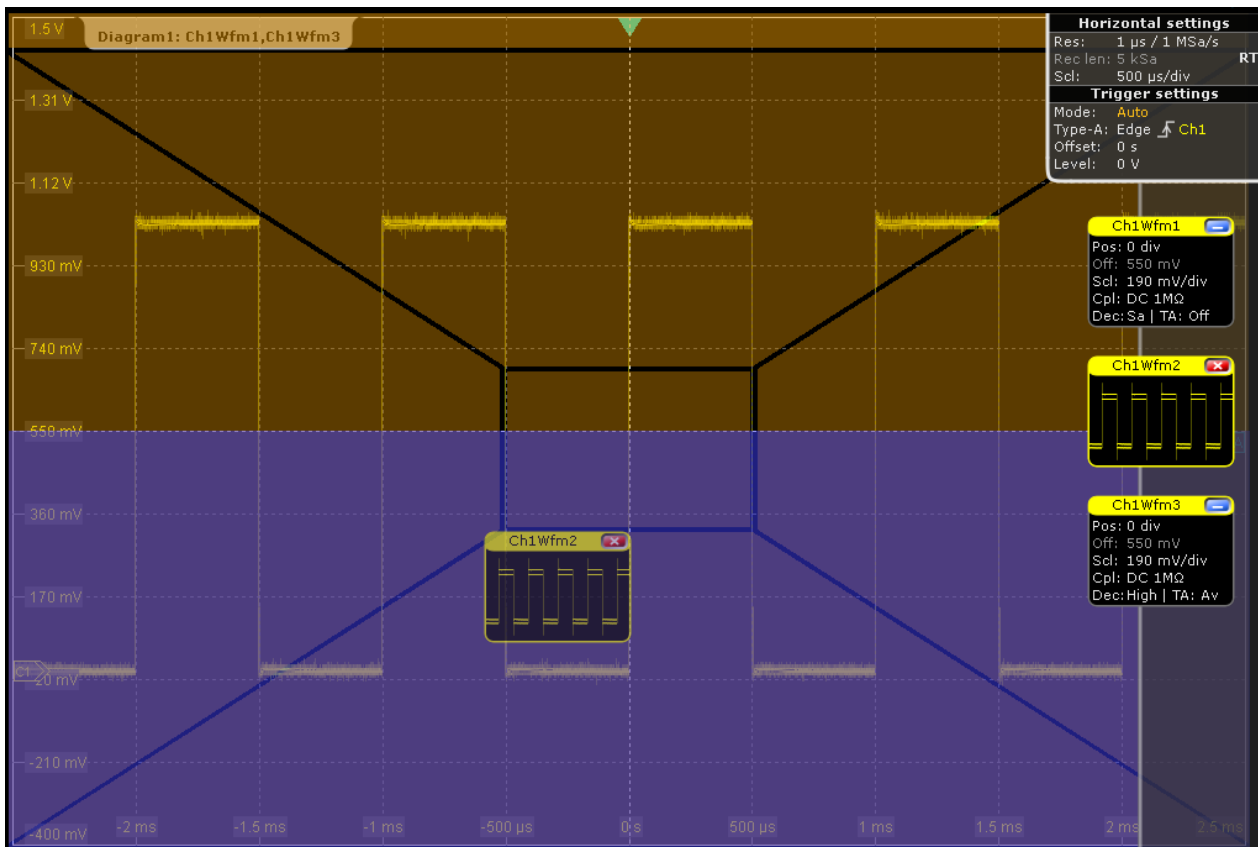

2. Drag the signal icon for "Ch1Wfm3" to the bottom half of the diagram so it covers an area beneath "Ch1Wfm2" and drop it there.

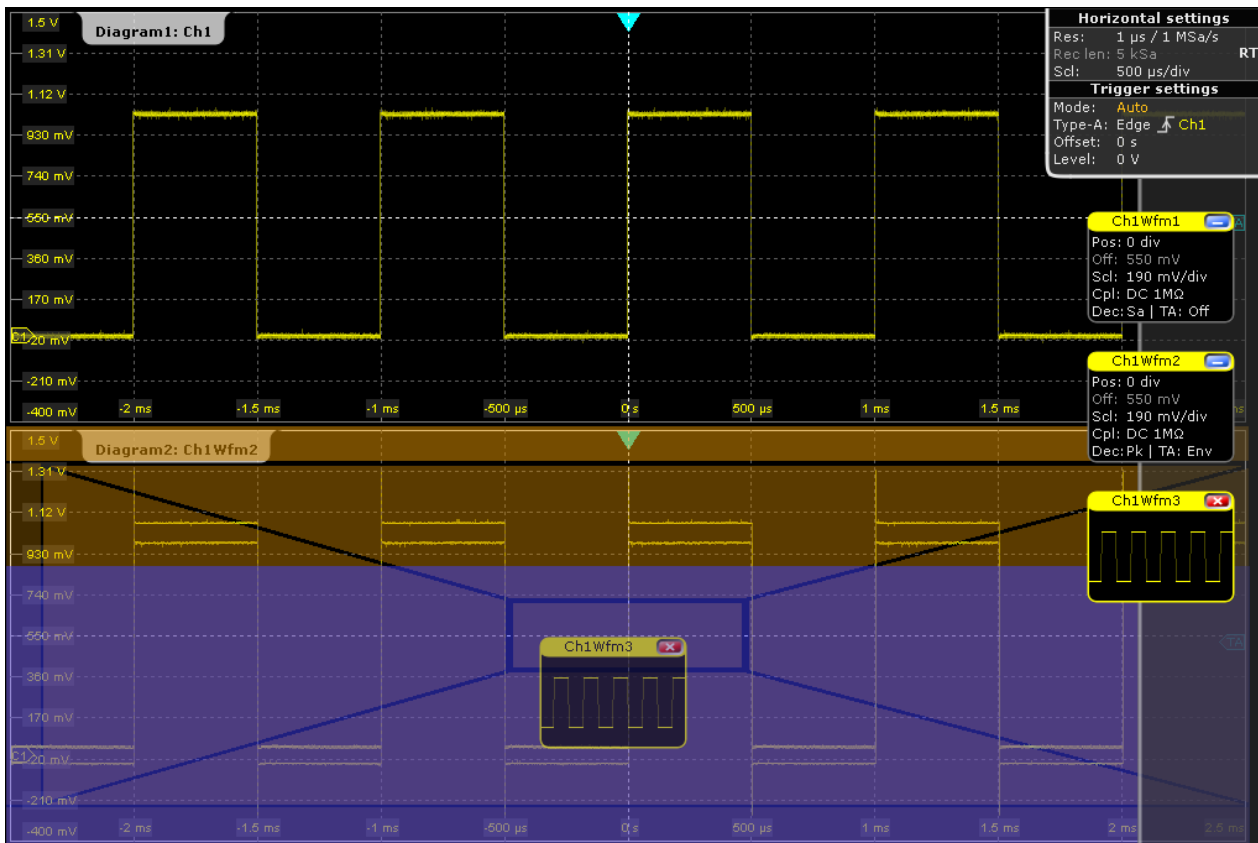

The three waveforms are now displayed in separate diagrams.

3. Rename the diagrams so the label indicates what is displayed:
 - a) Double-tap the label for "Diagram 1: Ch1".
 - b) On the on-screen keyboard, enter *Original*.
 - c) Tap ENTER.
 - d) Repeat these steps to rename "Diagram 2: Ch1Wfm2" to *Envelope*.
 - e) Rename "Diagram 3: Ch1Wfm3" to *Average*.

The diagram titles are shown together with the waveform number that is displayed in the diagram.

- To change the size of a diagram, drag its horizontal edge to the required position.

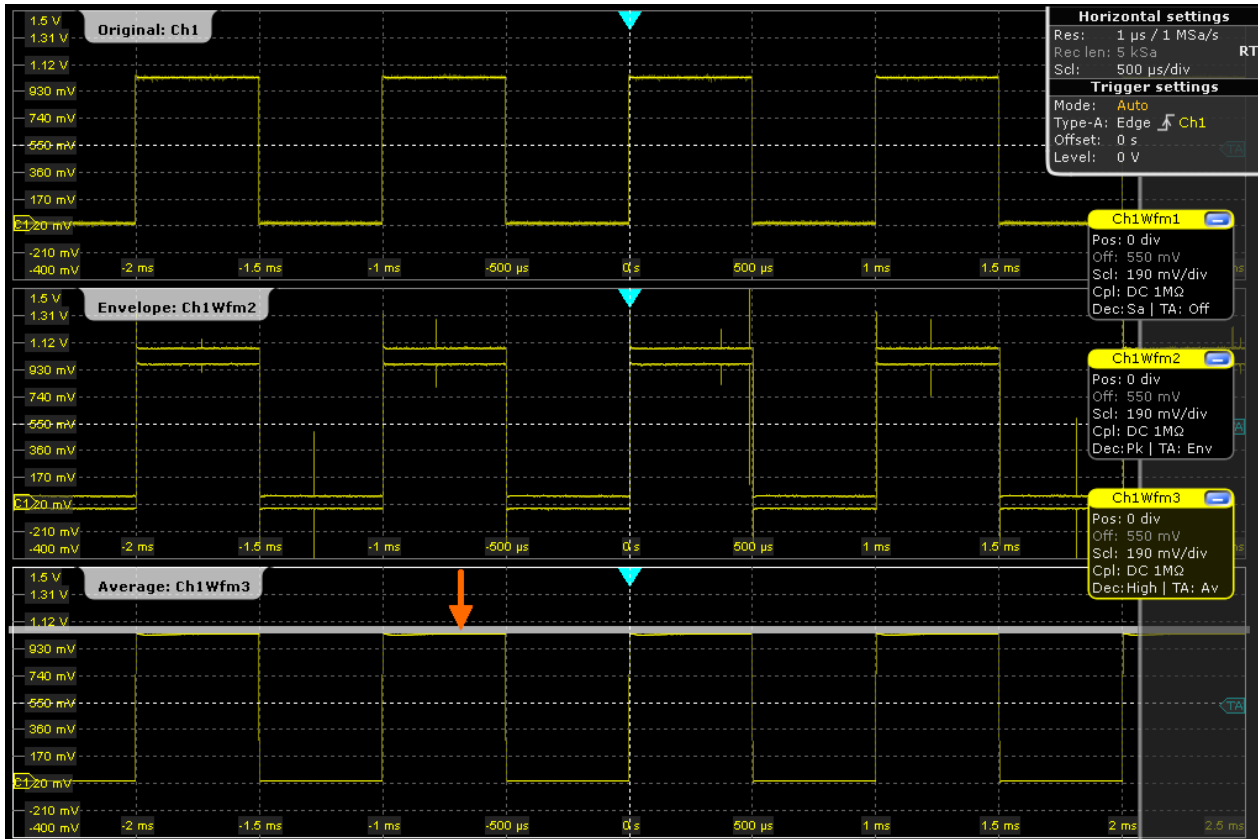

To delete waveform diagrams

For the procedures in the following chapters we only require the original waveform diagram, so we will close the other two.

- Minimize the waveform in diagram "Envelope: Ch1Wfm2": tap the "Minimize" icon of the "Ch1Wfm2" signal icon.

The diagram is removed and the signal icon in the signal bar displays a live view of the signal.

- Tap the red "Close" button of the signal icon for "Ch1Wfm2".

The signal icon is removed from the signal bar, the waveform is switched off.

- Switch off the "Average:Ch1Wfm3" waveform using the toolbar function:

- Tap the "Delete" icon on the toolbar.



- Tap the waveform in the "Average:Ch1Wfm3" diagram.

The waveform is switched off, its signal icon and the empty diagram are removed.

2.3.4 Changing the Waveform Scaling and Position

As you can see on the y-axis of the display, the calibration signal has a vertical offset of about 550 mV. The value can differ.

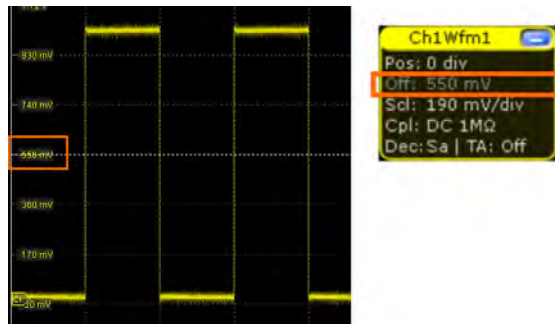

This value is also indicated in the signal icon ("Off" = offset). If you press the key for the input channel 1 (CH1), the "Vertical" settings dialog box also displays the "Offset" value. The offset is the DC component of the signal.

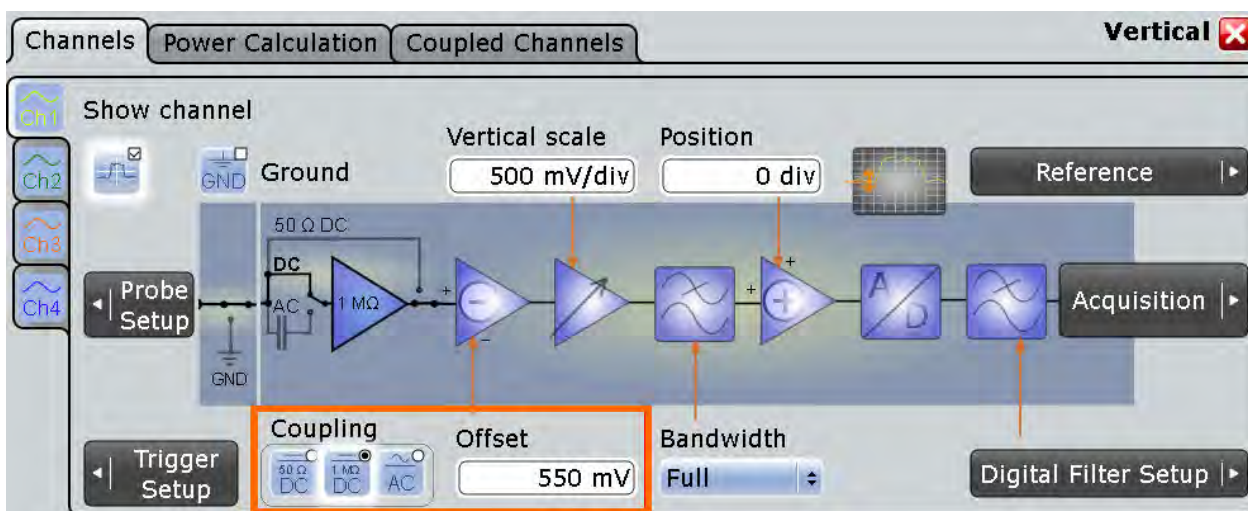

If you use a passive probe, you can filter the DC component by using the AC Coupling function, then quickly find the new trigger level, and try out the scaling functions:

1. Press the CH1 key on the front panel (in the VERTICAL area) to display the "Vertical" dialog box.
2. Change the "Coupling" to AC, and close the dialog box.

The DC component of the signal is eliminated; the waveform position moves down vertically and is now centered around 0 V.

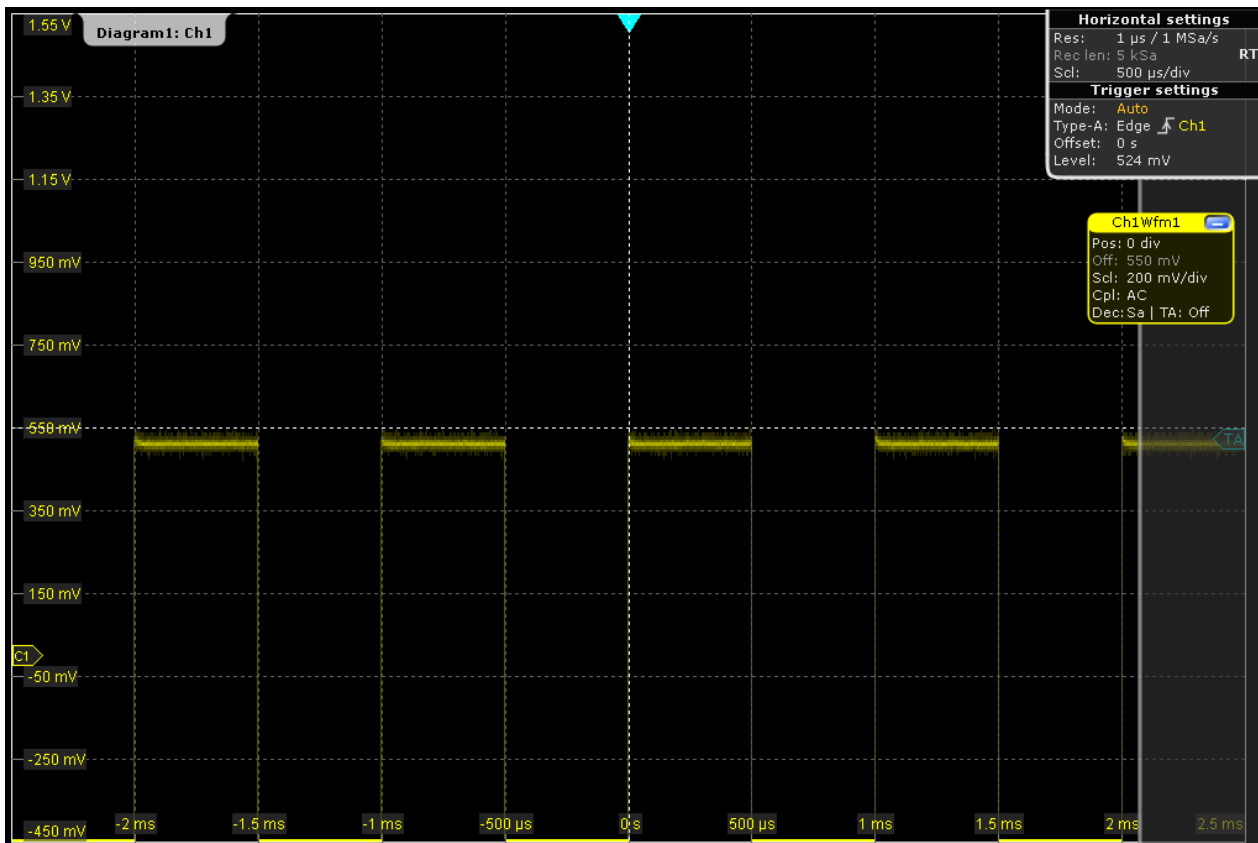

3. To move the waveform back to the center of the screen, eliminate the offset in the vertical settings:
 - a) Press the CH1 key on the front panel (in the VERTICAL area) to display the "Vertical" dialog box again.
 - b) Enter 0 V in the "Offset" field.

The waveform is now displayed in the center of the display, with the x-axis crossing at 0 V.

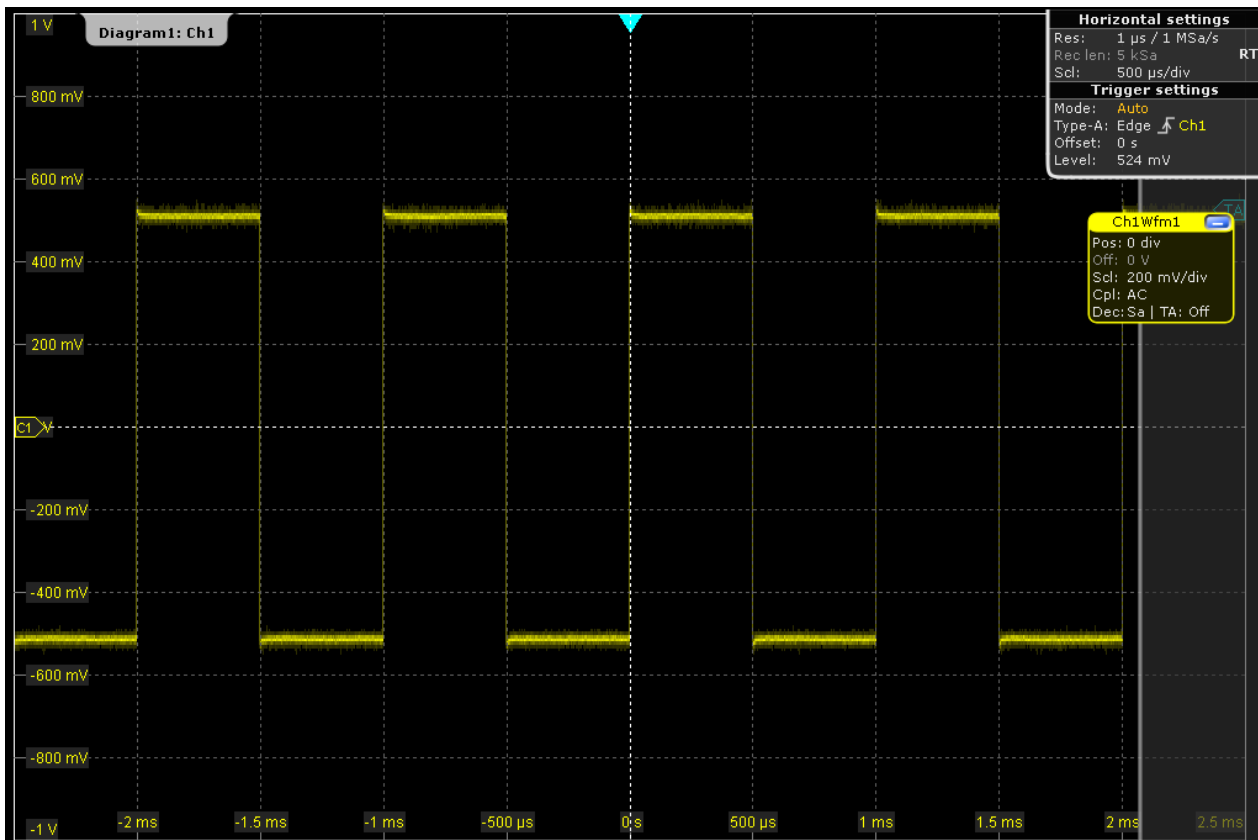

- To examine one pulse in the signal in more detail, turn the horizontal "Scale" rotary knob.

The current scale factor per division is displayed in the upper left-hand corner of the display while you turn the knob. You can switch between a small and large step size in the scaling factor by tapping the step icon.

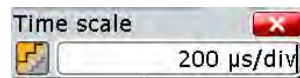

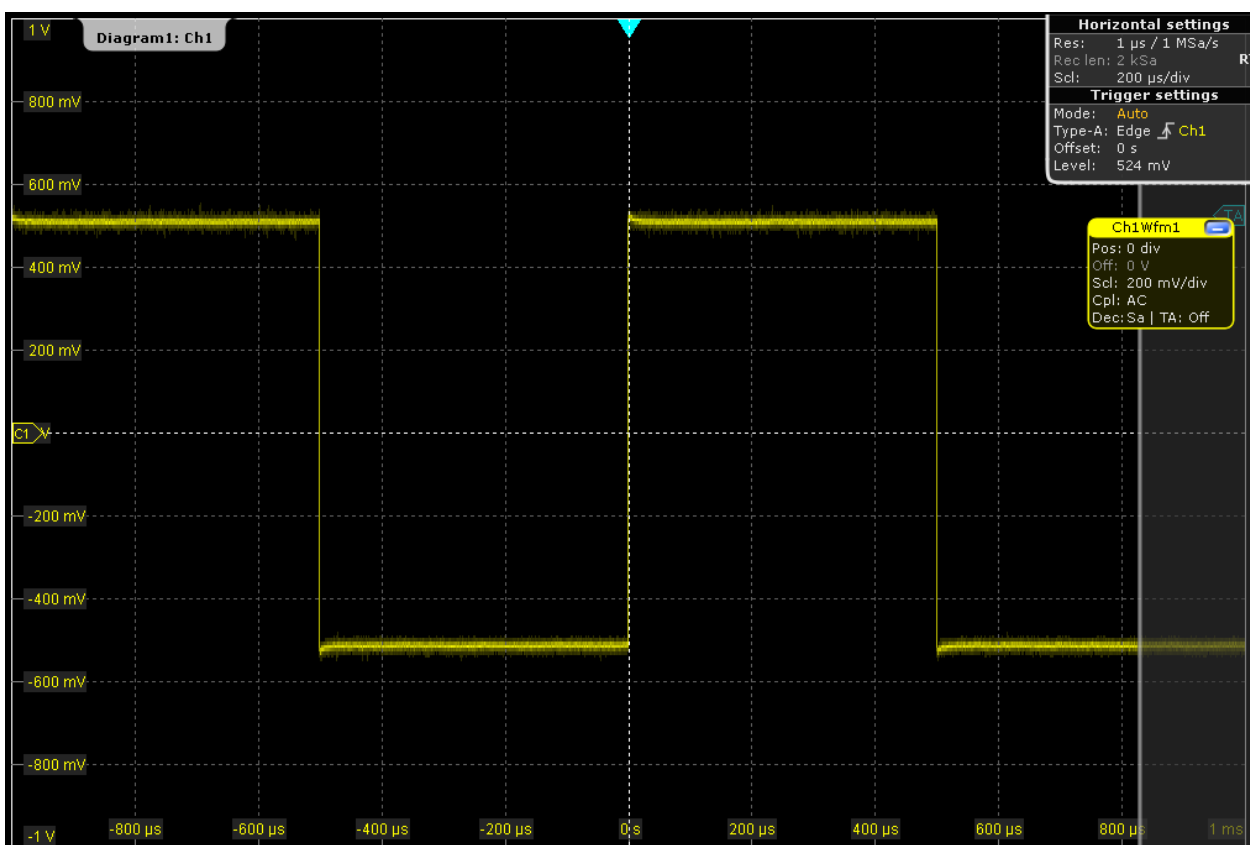

- To return to the original scaling, you can either turn the rotary knob back in the other direction, or use the UNDO key on the front panel (in the NAVIGATION area). Press the UNDO key repeatedly until the original scaling is displayed. Press the REDO key to retrace the undone steps. Thus, you can toggle between the two displays using the undo and redo keys until you perform a different action. Instead of using the UNDO and REDO keys, you can tap the corresponding icons on the toolbar.

If you use an active single-ended probe, you can measure the DC component of the signal directly at the probe tip by means of the integrated R&S ProbeMeter:

- On the "Vertical" menu, tap "Probe Setup".
- Make sure that the correct channel is selected on the left tab.
- In the "ProbeMeter" section, tap "Enable".

A result box shows the DC voltage measured by the R&S ProbeMeter.

2.3.5 Zooming into the Display

Using the SCALE rotary knobs you can change the scaling of the time base and signal amplitudes in order to enlarge the waveform. If you need to see more details, use the zoom function.

1. Restore the default signal channel settings by pressing the PRESET and AUTOSSET keys.
2. On the toolbar, tap the "Zoom" icon.



3. Tap the position in the diagram that you want to define as one corner of the zoom area, then drag your finger to the opposite corner of the zoom area. While you drag your finger on the touchscreen, a dotted rectangle is displayed to indicate the current zoom area. When the rectangle covers the required zoom area, remove your finger.

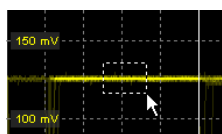

The indicated area is magnified in a new zoom diagram. The original diagram is displayed with the zoom area indicated as a rectangle.

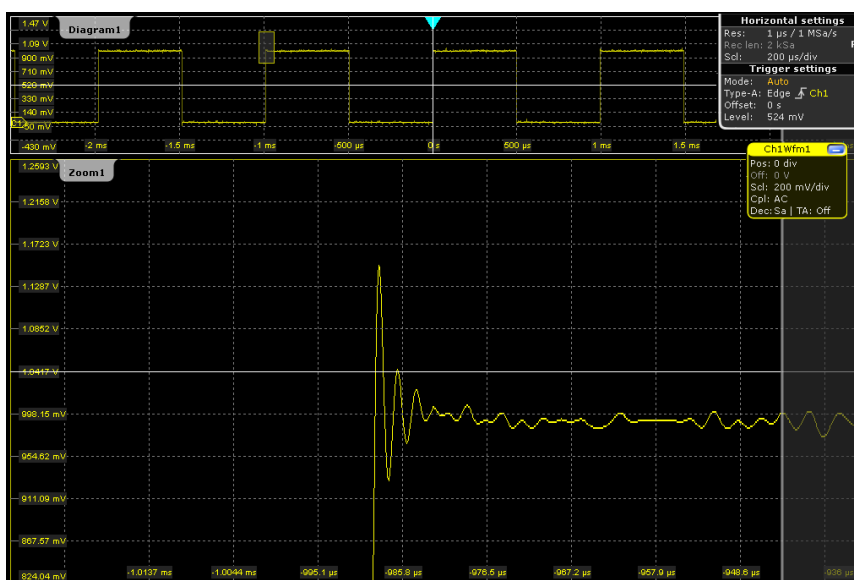

4. To remove the zoom window and make room on the display for other results, tap the "Delete" icon and then the zoom window.



2.3.6 Displaying the Waveform History

During a continuous acquisition, the acquired data is stored in the memory and the current acquisition is shown on the display. When the acquisition was stopped and a new acquisition is started with RUN CONT or RUN xSINGLE, the memory is cleared and

written anew. The history accesses and displays the samples that were saved before the current acquisition.

In the following example, you will acquire 10 waveforms, then display the 3 most recent waveforms.

1. Press the ACQUISITION key on the front panel (in the HORIZONTAL area) to open the "Horizontal" settings dialog box.
2. Set the "Average count" to 10 to perform 10 waveform acquisitions.
3. Close the "Horizontal" dialog box.
4. Press the RUN \times SINGLE key on the front panel (in the TRIGGER area) to start the acquisition cycle.

Ten waveform acquisitions are performed. The most recent acquisition is displayed in the diagram.

5. Press the HISTORY key on the front panel (in the ANALYZE area).
The quick access "History" dialog box appears and the history mode is enabled.
6. Tap "Play".
The ten stored waveforms are displayed one after the other, but very fast.
7. In the "Current acq." field, enter -4 to display the sixth waveform (counted from acquisition start). The latest acquisition has the number 0, the oldest has -9.



8. Tap the  icon to open the "History" setup dialog box.
9. Enter -2 in the "Start acq" field, then tap "Newest" to enter 0 in the "Stop acq" field.
Thus the three latest acquisitions will be displayed.
10. In the "Replay time per acq." field, enter 1 s to display each waveform for one second.
11. Enable the "Auto repeat" option to see the three waveforms repeatedly.



12. Tap "Play" to start the display.
The currently displayed waveform is indicated in the "Current acq." field.
13. Close the "History" dialog box so you can see the waveform better.
14. Tap "Play" again (now labeled "Running" due to the running display) to stop the display.
15. Close the quick access "History" dialog box.
The history mode is disabled, and the HISTORY key is no longer illuminated.

2.3.7 Showing Basic Measurement Results

Using the R&S RTO you can perform and display different measurements simultaneously. The color of the results in the result table corresponds with the source waveform color.

2.3.7.1 Performing a Cursor Measurement

1. Restore the default signal channel settings by pressing the PRESET and AUTOSET keys.
2. Tap the "Cursor" icon on the toolbar.



3. Tap the diagram in which you want to set the cursors, or draw a rectangle on the screen to position the cursor lines.
The cursor lines appear in the diagram and the "Cursor Results" box opens. The measured values of the waveform at the cursor positions are displayed.
4. You can move the cursor lines in the diagram manually, or adjust the cursor type and position in the result box.

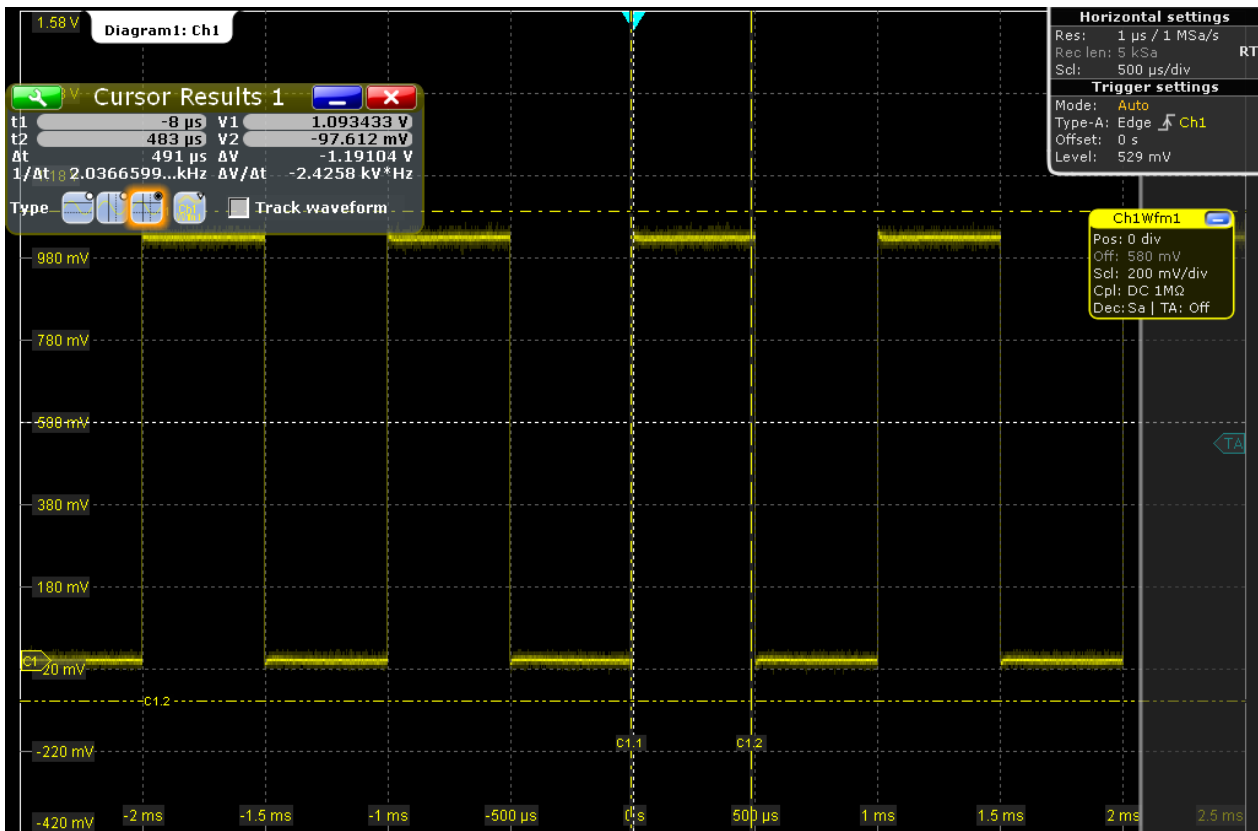

- To save space in the display, minimize the result box. The most important results are displayed and updated in the result icon, as well.

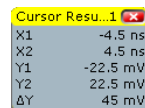

- To remove the result icon and make room on the display for other results, tap the red cross on the icon label.

2.3.7.2 Performing an Amplitude Measurement

In order to measure the amplitude of a pulse quickly, perform a simple amplitude measurement in the time domain.

- Restore the default signal channel settings by pressing the PRESET and AUTOSSET keys.
- Tap the "Measurement" icon on the toolbar.



- Tap the diagram in which you want to perform the measurement, or draw a rectangle on the screen to define a gate area for which the amplitude is measured.

The "Amplitude" measurement is selected and enabled, using the selected (focused) waveform as the source.

The "Measurements" result box with the measured amplitude is displayed.

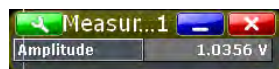

4. To display statistical results for the measurement, tap the icon in the result box, or press the MEAS key on the front panel (in the ANALYZE area). The "Measurements" dialog box is displayed.
5. Enable the "Statistics" option, and close the dialog box. The results in the result box are extended by statistical values.
6. To select further measurements, tap the icon in the result box, or press the MEAS key on the front panel to display the "Measurements" dialog box.
7. Under "Additional amplitude/time measurements", tap "Activate..." and select the required measurement types. For example, select *High*, *Low*, *Min*, and *Max* to display the high level, low level, minimum and maximum values, respectively.

The measurement results are displayed in the result box.

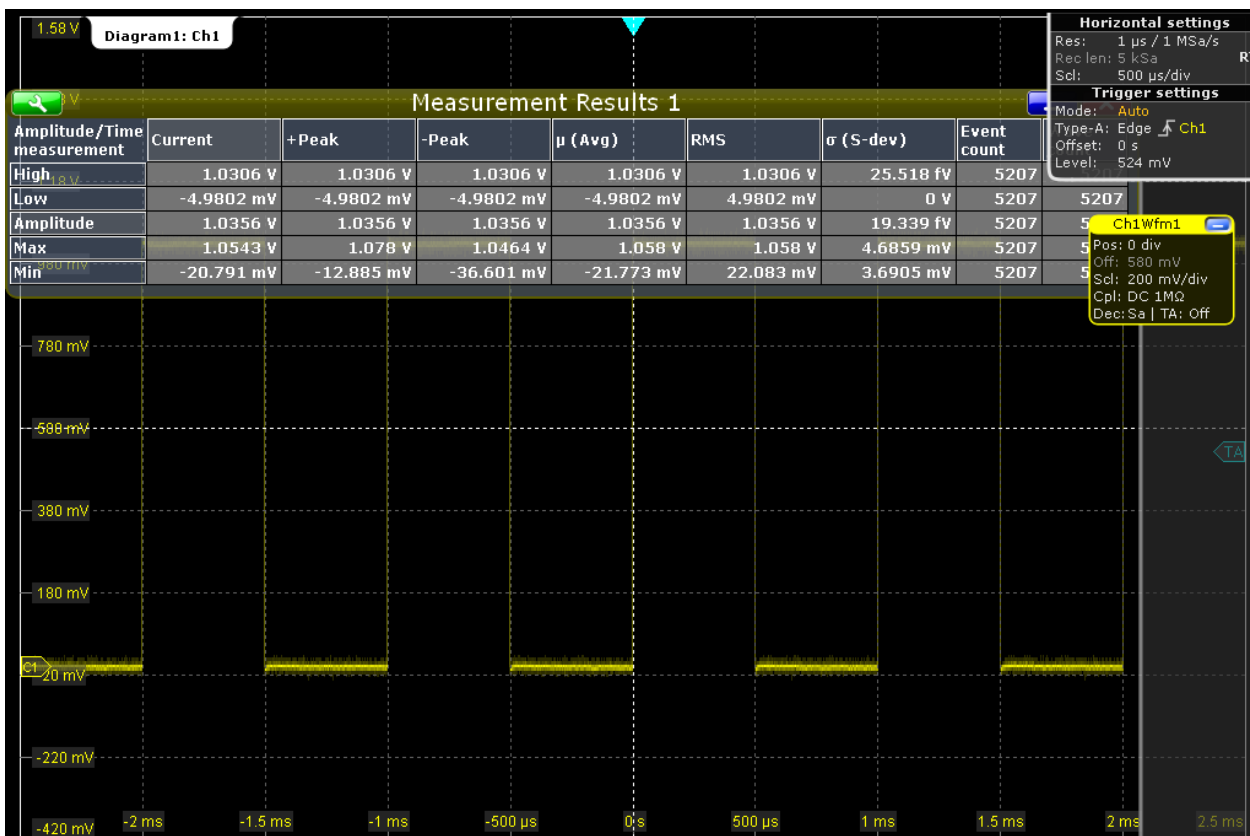

8. To save space in the display, minimize the result box. The most important results are displayed and updated in the result icon, as well.

Measureme...1	
High	124.51 mV
Low	-124.51 mV
Amp.	249.01 mV
Max	124.51 mV
Min	-124.51 mV

9. To view all measurement results without covering part of the waveform display, move the result table to its own diagram area:

- a) Drag the result icon to the diagram area.
- b) Drop the waveform in the target area.

Now you can see both the measurement results and the waveform.

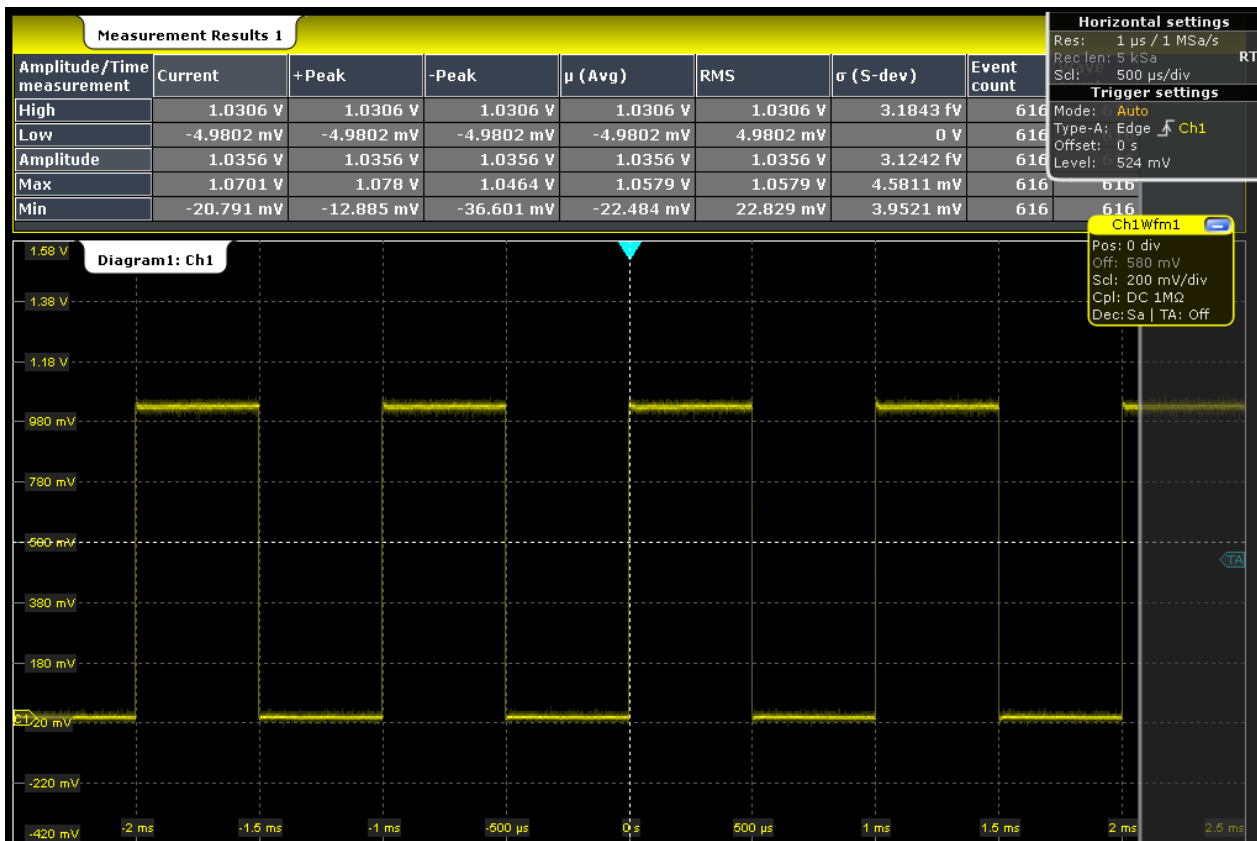

10. Minimize the measurement results display: tap the title of the results box, and draw it to the signal bar. Do not close it, as you require the results for the Search example (see chapter 2.3.10, "Performing a Search", on page 62).

2.3.7.3 Displaying a Histogram

Histograms are useful to analyze the occurrence of measurement values statistically.

1. Tap the "Histogram" icon on the toolbar.



2. Tap the diagram in which you want to generate the histogram, or draw a rectangle on the screen to define the area on which the histogram is to be based.

The histogram range is indicated in the diagram and a vertical histogram is defined and displayed.

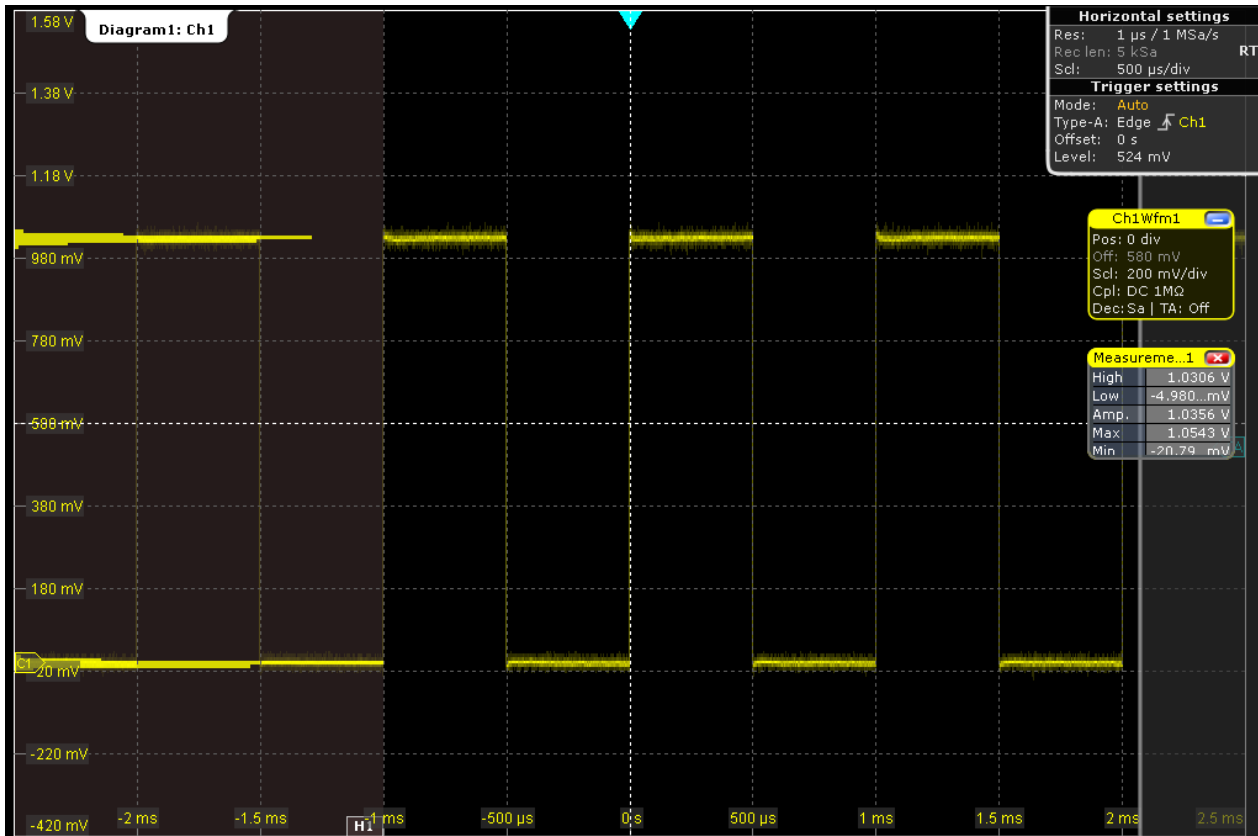

3. To display the measurement results for the histogram, tap the "Measurement" icon on the toolbar.



4. Tap the histogram.
The waveform count for the histogram is displayed.
5. To display further measurement results for the histogram, tap the  icon in the result box, or press the MEAS key on the front panel to display the "Measurements" dialog box.
6. Under "Additional histogram measurements", tap "Activate..." and select the required results. Additionally, enable the "Statistics".
The histogram measurement results are displayed in the result box.

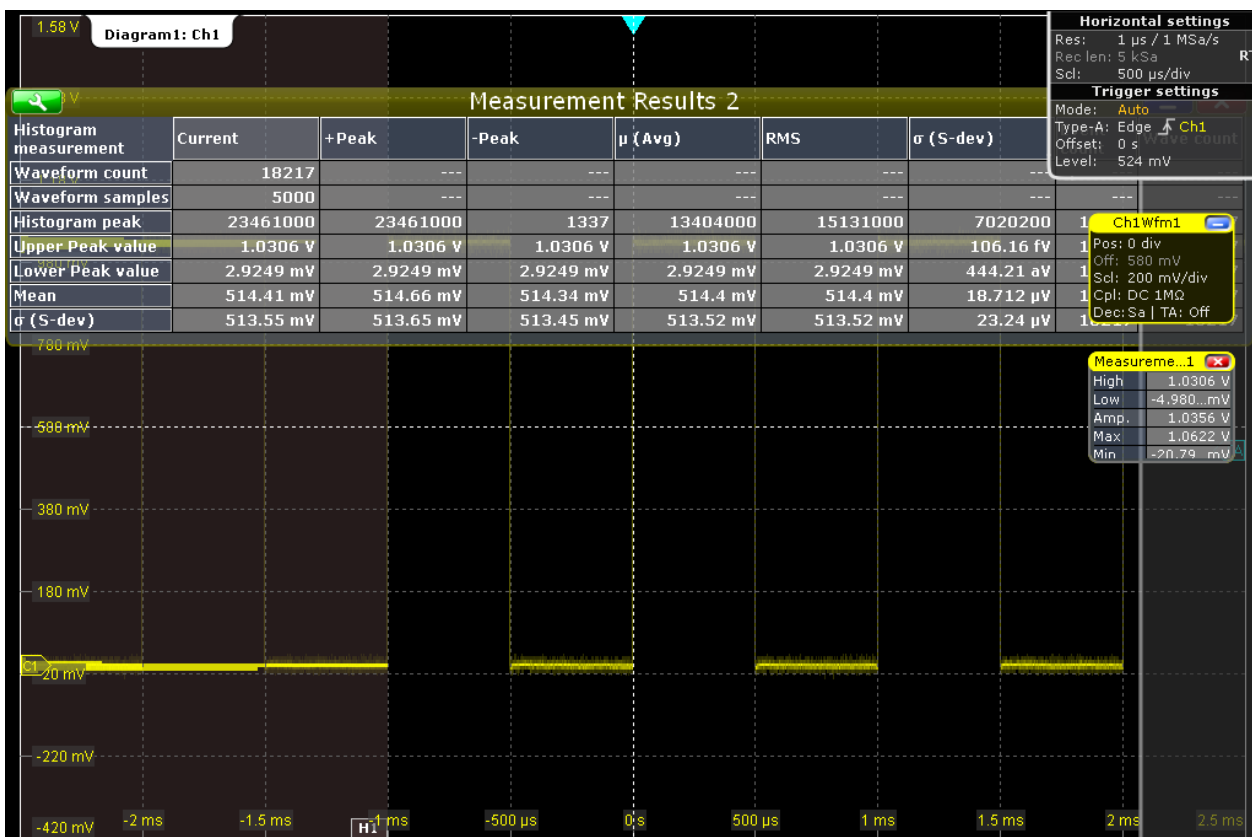

- To close the measurement results display, tap the "Delete" icon on the toolbar and then the results.



- To remove the histogram, tap the "Delete" icon on the toolbar and then the histogram. Both the histogram and any measurements based on that histogram are deactivated.

2.3.8 Performing an FFT Analysis

During FFT analysis, a signal in the time domain is converted to a spectrum of frequencies. A basic FFT waveform can be displayed very quickly.

- Restore the default signal channel settings by pressing the AUTOSET key.
- Tap the "FFT" icon on the toolbar, then tap the CH1 waveform.



A math waveform is configured that uses the "Mag(FFT(x))" operator with "Ch1Wfm1" as source. The FFT waveform is displayed in a new diagram.

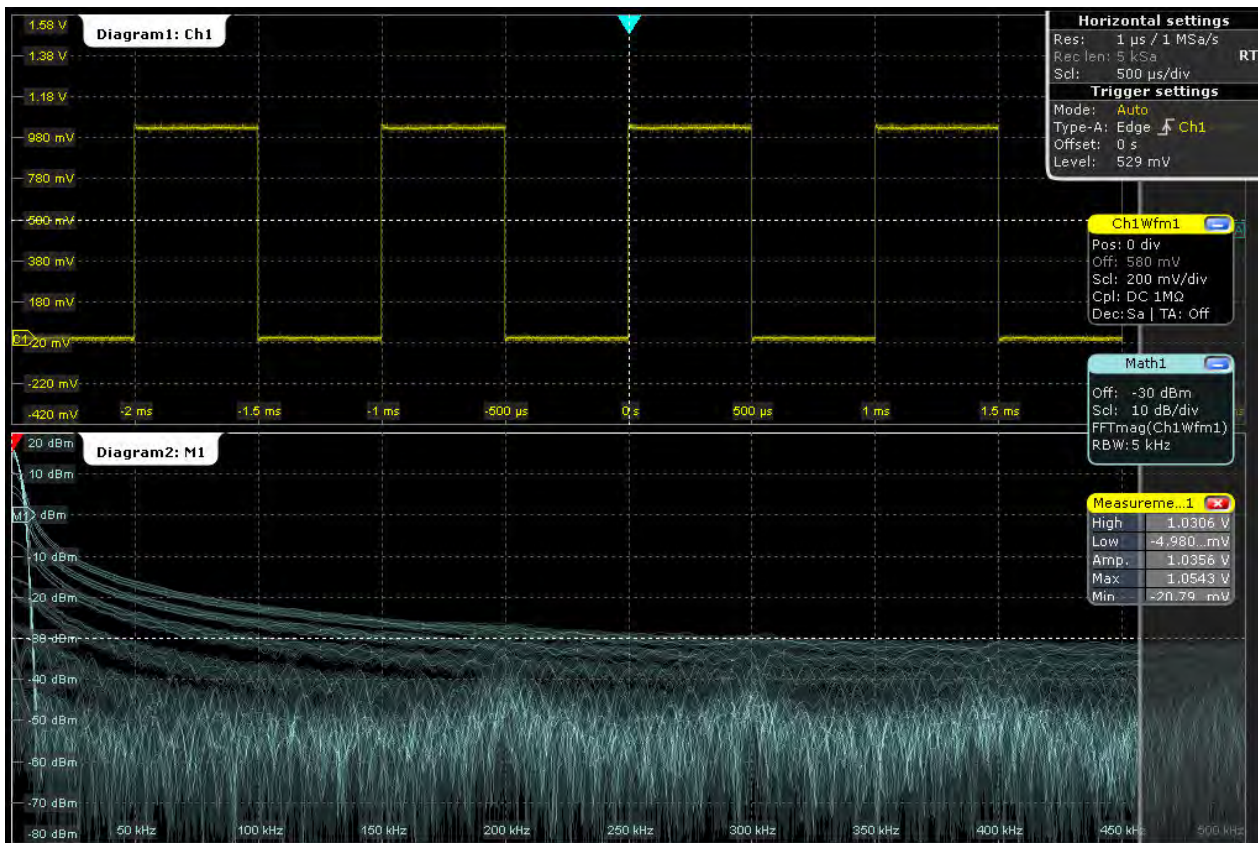

- To perform a spectrum measurement on the math channel, tap the "Measurement" icon on the toolbar.



- Tap the FFT waveform.
The spectrum measurement results are displayed in a result box.



5. Double-tap the title of the FFT diagram.
The "FFT Setup" dialog box opens.
6. Tap "Center frequency" and set it to 1 kHz . Turn the NAVIGATION key until the required value is displayed.
7. Set "Frequency span" to 1 kHz , and close the dialog box.

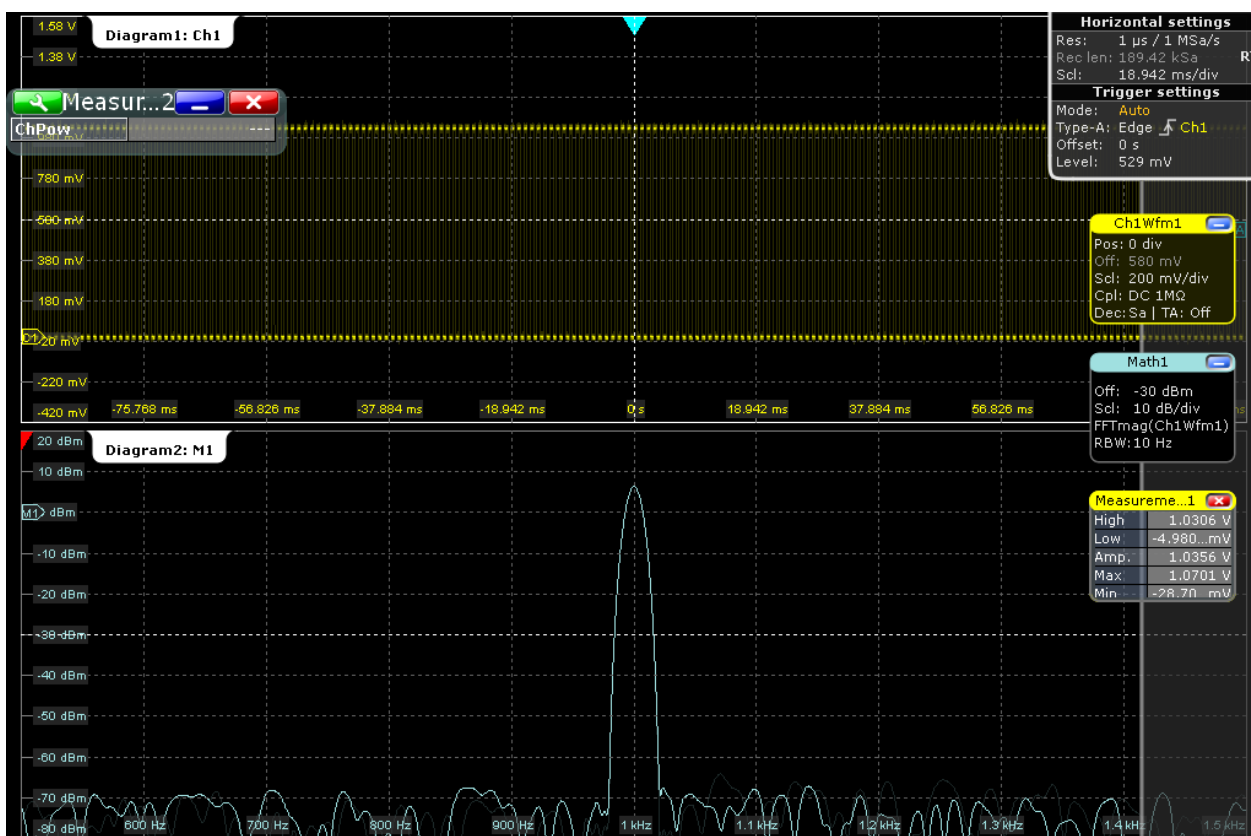

- To remove the FFT results, tap the "Delete" icon and then the FFT waveform.



Close the "Measurement 2" result box.

2.3.9 Performing Mathematical Calculations

In addition to the measured waveforms, you can display calculated data to compare the current measurement result with.

For example, you can rescale the waveform and display it in the same diagram as the original waveform.

- Press AUTOSET.
- Press MATH to display the "Mathematics" menu.
- In the "Setup" tab, select the "Basic" tab.
- Tap the "Source1" icon and select *Ch1Wfm1*.
- Tap the "Operator" icon and select *Rescale*.
- For "a", enter the vertical scaling factor, e.g. 4.

7. Under "b", enter the vertical position offset, e.g. 2.
Look at the lower part of the dialog box and note that the instrument adjusts the "Vertical scale" and "Vertical offset" of the math waveform automatically.
8. Tap "Enable" to display the first math waveform.
The original and the rescaled waveforms are displayed.

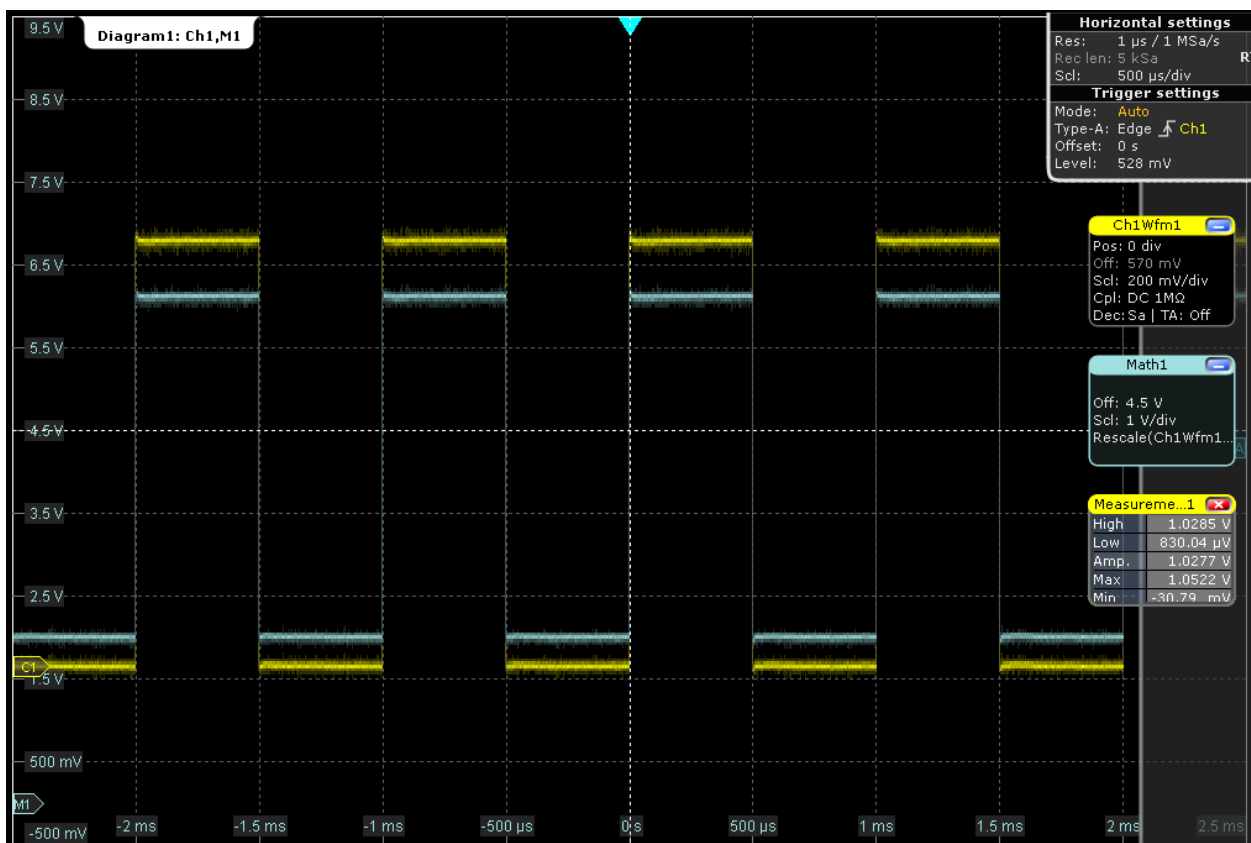

9. To remove the math waveform, tap the "Delete" icon and then the math waveform.
Or, tap the signal icon of the math waveform to minimize the waveform, and then close the signal icon.



2.3.10 Performing a Search

In the following search, you will detect positive and negative overshoots, i.e. values that exceed the high or low levels. To determine the search conditions you can use the results of the measurement example described in [chapter 2.3.7.2, "Performing an Amplitude Measurement"](#), on page 54.

To configure a search for overshoots

1. Press the SEARCH key on the front panel (ANALYZE area) to open the "Search" dialog box.
2. Tap the "Add" icon to create a new tab for the new search configuration.



3. Enter a name for the search configuration using the displayed on-screen keyboard.
4. Select channel 1 as the "Source".
5. Define the search conditions for the search:
 - a) Select the "Window" tab.
 - b) As the "Upper level", enter the result for the "High" level measurement.
 - c) As the "Lower level", enter the result for the "Low" level measurement.
 - d) As the "Vertical condition", select *Exit* to find values that are outside the range defined by the high and low levels.
 - e) Tap "Select" to include the search condition in the search.

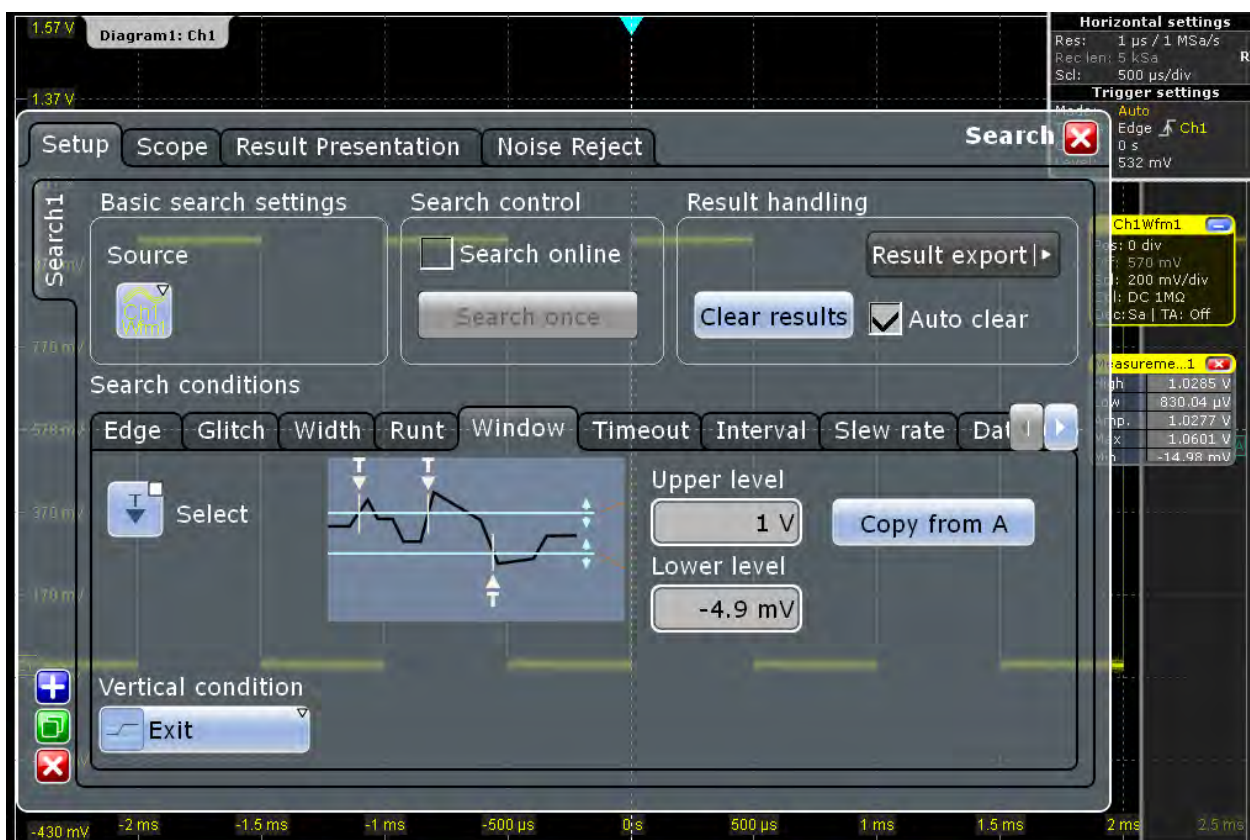

6. Tap "Clear results".
7. Select "Search once" to perform the search on the acquired data.

- On the "Results presentation" tab, select "Show search zoom windows" to show a zoom window for the currently selected search result.

The detected overshoots are listed in the search result table. The last result that was found is displayed in the search zoom window. Vertical lines indicate the time values for which a result was found.

- In the results table, tap the row of the search result that you want to display in the search zoom diagram.

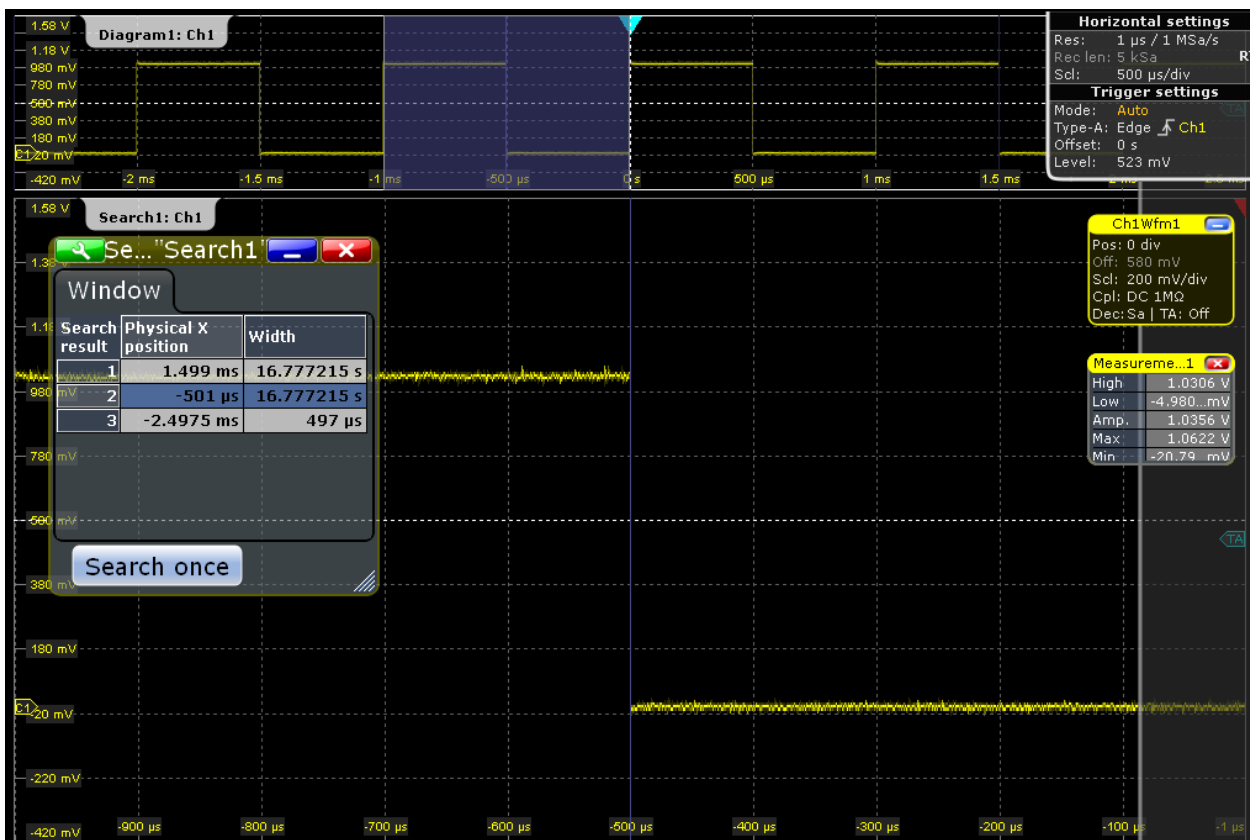

2.3.11 Performing a Mask Test

In the following example you will perform a mask test to determine whether the signal exceeds a rectangular area.

- Restore the default signal channel settings by pressing the PRESET and AUTOSSET keys.
- Tap the "Masks" icon on the toolbar.



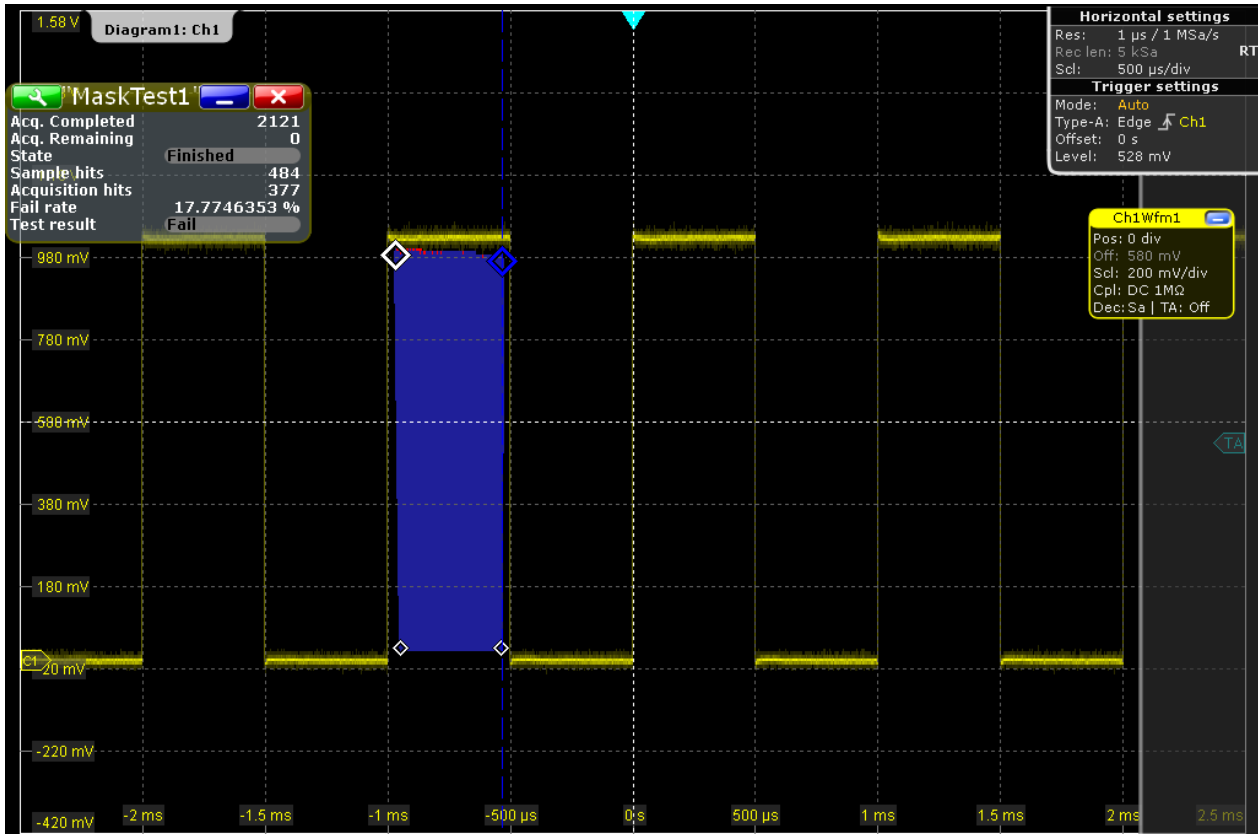

3. Tap the corner points of the first mask segment on the touchscreen. Select the corner points of one complete pulse, with a minor offset to the inside. To finish the mask definition, double-tap the last point.

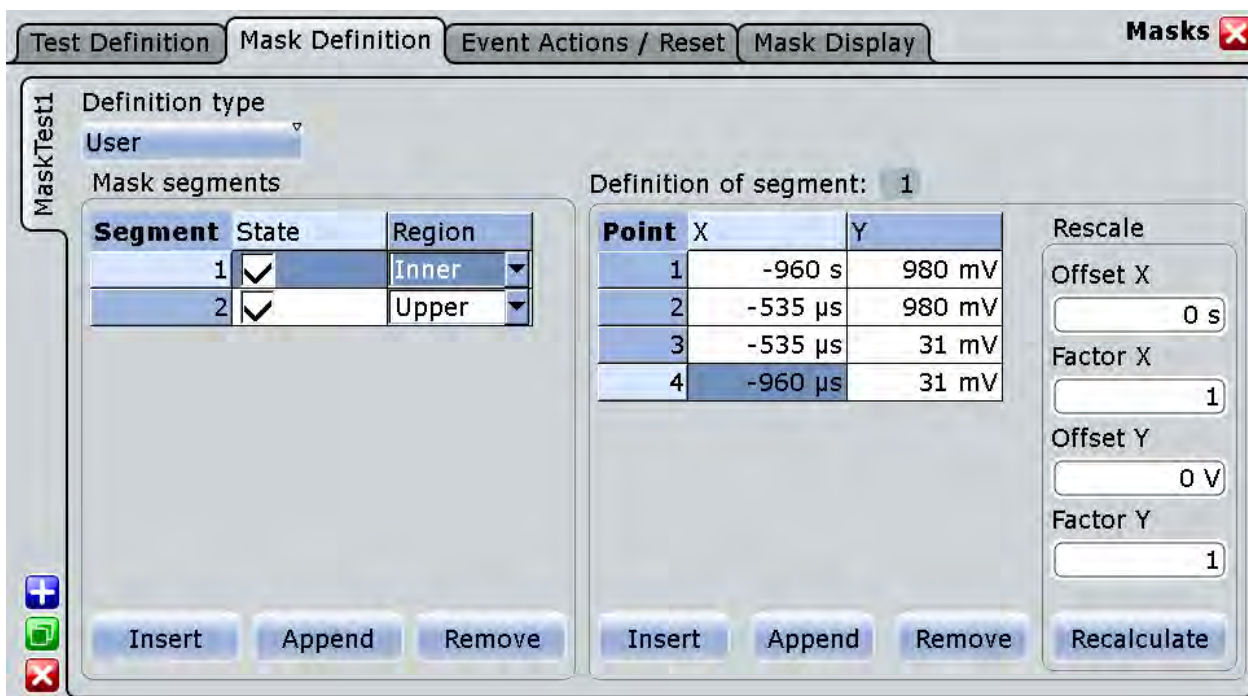

4. To define the further mask test settings, press the MASKS key on the front panel (in the ANALYZE area), and select the "Mask Definition" tab.
5. If necessary, correct the mask segment points you defined graphically in the "Mask Definition" tab. In the "Region" column of the mask segment, "Inner" is selected. That means, a mask hit is detected if the signal is inside the segment.
6. Insert another mask segment above the positive pulse:
 - a) Tap the "Append" button under "Mask segments".
 - b) In the "Region" column of the new mask segment, select "Upper". In this case, a mask hit is detected if the signal is above the mask limit line.
 - c) Under "Definition of segment", tap "Insert" twice to insert two points.
 - d) Enter the x and y-values to define a line beneath which the values of the positive pulse should remain.



7. Insert another mask segment graphically beneath the negative pulse:
 - a) Close the dialog box and tap one of the mask segments on the touchscreen. The blue color indicates that the segment is selected, and the new segment will be added to the same mask test.
 - b) Tap the "Masks" icon on the toolbar.

 - c) Tap the first point of a line above which the values of the negative pulse should remain.
 - d) Double-tap the second point of this line.
 - e) Tap outside the mask to deselect the mask segments.
8. Tap the  icon in the result box, and select the "Test Definition" tab.
9. Select channel 1 as the "Source".
10. Define the number of tolerable sample hits in the "Tolerance" field.

A test has failed if the number of sample hits exceeds the limit of "Violation tolerance" hits.
11. Select the "Event Action / Reset" tab.
12. For the "Stop acquisition" action select *On violation*. If the violation tolerance is exceeded, acquisition is stopped.

The results of the mask test are shown in the "MaskTest" results box. Mask hits are also indicated as red points in the mask segment in the diagram.

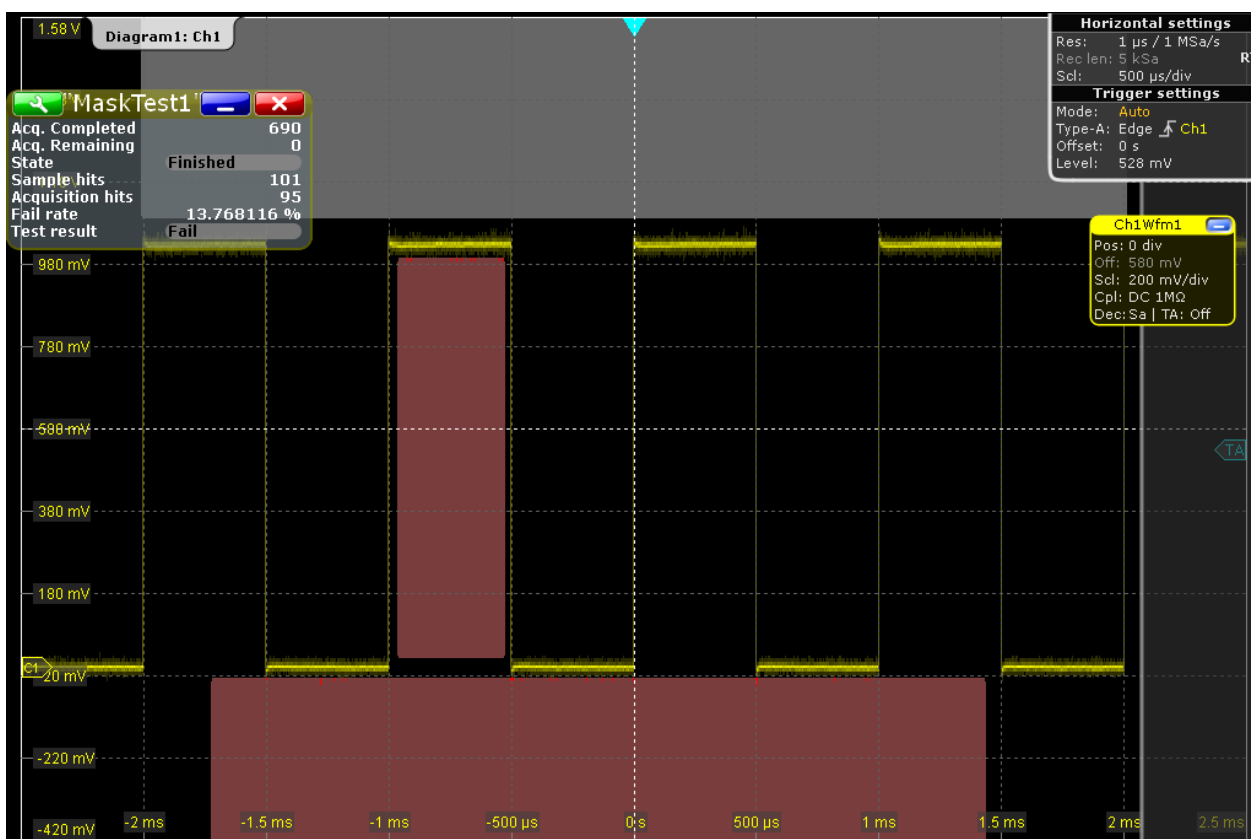

13. Press RUN CONT to start the next acquisition and watch the screen.

14. Close the "MaskTest" results box by tapping the red cross in the label.

2.3.12 Printing and Saving Screenshots

You can print or save screenshots of the current display to document your results. In the following example, you will print the current display as a black and white graphic with inverted colors, i.e. a dark waveform is printed on a white background. Then you will save the screenshot to a file.

1. Press the PRINT key on the front panel (in the SETUP area on the left) to display the "Print" dialog box.
2. Tap "Color" and select *Black and white*.
3. Enable the "Inverse color" option.
4. To add a textual comment or highlight a special area of the waveform, tap "Edit image".

The print image is opened in the Paint application. Edit the image as necessary, then save the file and close the Paint application to return to the "Print" dialog. Then print or save the (edited) image as described in the following procedure steps.

5. If a printer is connected to the instrument, or the instrument is connected to the network, select an installed printer in the printer selection box. Tap "Print" to print the image to the selected printer.
6. Tap "Save" to save the image to a file.
The default file name is `RTOScreenshot_<date>_<index>_<time>.png`. It is saved to the following directory:
Windows XP:
`C:\Documents and Settings\All Users\Documents\Rohde-Schwarz\RTO\Screenshots.`
Windows 7:
`C:\Users\Public\Documents\Rohde-Schwarz\RTO\ScreenShots`

2.3.13 Saving Data

After a measurement with the R&S RTO you can save the resulting waveform data for further evaluation or comparison. You can also save measurement results, and device settings in order to repeat or restore previous measurements.

- ["Saving waveform data"](#) on page 68
- ["Saving data of an acquisition series"](#) on page 69
- ["Saving measurement results"](#) on page 69
- ["Saving and restoring device settings"](#) on page 70

Saving waveform data

1. Press the FILE key on the front panel (in the SETUP area on the left).
2. Select the "Save/Recall" tab.
3. Select the "Waveforms" subtab.
4. Check the "Source" and set "Scope" to "Full Waveform".
If a cursor, zoom or measurement gate is defined, you can use these settings to export only a part of the waveform.
5. Under "Save to file", tap "Save As" to open the file selection dialog box.
6. Select the storage directory in the file selection dialog box:
Windows XP:
`C:\Documents and Settings\All Users\Documents\Rohde-Schwarz\RTO\RefWaveforms`
Windows 7:
`C:\Users\Public\Documents\Rohde-Schwarz\RTO\RefWaveforms`
7. Tap the keyboard icon and enter *Waveform1* on the online keyboard.



8. Tap "ENTER" to close the online keyboard.
9. Select the file type: "*.bin".
10. Tap "Save".

The waveform data is saved to the files `Waveform1.Wfm.bin` and `Waveform1.bin` in the selected directory.

Saving data of an acquisition series

1. Press the FILE key on the front panel.
2. Select the "Save/Recall" tab.
3. Select the "Waveforms" subtab.
4. Set the export scope of the waveform:
 - a) Check the "Source" and set "Scope" to "Full Waveform".
 - b) Tap "Data logging" to enable export all waveforms of a running acquisition.
 - c) Enter "Acq count" = 10, the number of subsequent waveforms to be saved.

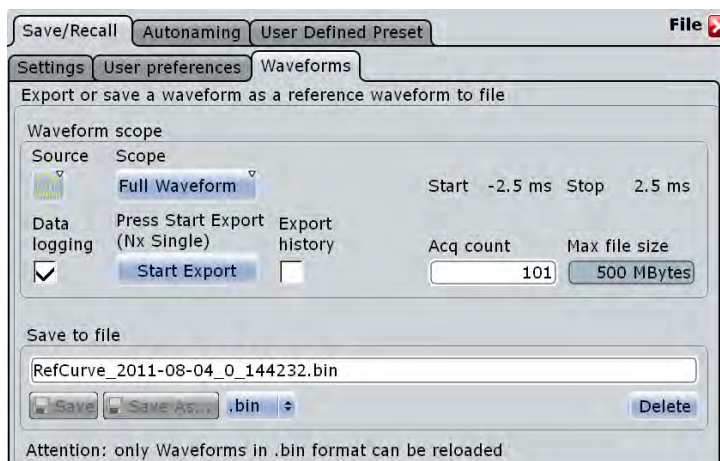

5. Tap "Start Export" to save the waveforms to the file that is named under "Save to file".

Saving measurement results

1. Perform a measurement as described in [chapter 2.3.7.2, "Performing an Amplitude Measurement"](#), on page 54.
2. Tap the  icon in the result box.
3. Tap the "Result export" button in the "Setup" tab.
4. In the table, select the results to be saved.
5. For further usage of the results, select the "CSV-Delimiter" that is used to convert the values in columns. For MS Excel, the semicolon is recommended.
6. Tap "Save".

The results are saved to the following folder:

Windows XP:

```
C:\Documents and Settings\All Users\Documents\Rohde-Schwarz\
RTO\ResultBoxExport.
```

Windows 7:

```
C:\Users\Public\Documents\Rohde-Schwarz\RTO\ResultBoxExport
```

The file name is created according to the autonaming settings.

Saving and restoring device settings

1. Press the FILE key on the front panel.
2. Select the "Save/Recall" tab.
3. Select the "Settings" tab.
4. Tap "Save As" and enter the path and file name.
Windows XP:

```
C:\Documents and Settings\All Users\Documents\Rohde-Schwarz\
RTO\SaveSets\Settings_Meas1.dfl.
```

Windows 7:

```
C:\Users\Public\Documents\Rohde-Schwarz\RTO\SaveSets\
Settings_Meas1.dfl
```
5. Tap "Save".
6. Press the PRESET key on the front panel to restore the default instrument settings.
7. In order to repeat the initial measurement, load the saved device settings. Press the FILE key on the front panel.
8. Select the "Save/Recall" tab.
9. Select the "Settings" tab to load instrument settings.
10. Tap "Open" and select the settings file from the file selection dialog box:
Windows XP:

```
C:\Documents and Settings\All Users\Documents\Rohde-Schwarz\
RTO\SaveSets\Settings_Meas1.dfl.
```

Windows 7:

```
C:\Users\Public\Documents\Rohde-Schwarz\RTO\SaveSets\
Settings_Meas1.dfl
```
11. Tap "Select".
The device settings are restored and you can repeat the initial measurement.

2.4 Operating the Instrument

There are three ways to operate the R&S RTO.

Manual operation

Use the touchscreen, keys and rotary knobs, or an optional mouse and/or keyboard. The principles of manual operation are explained in this section.

Remote control

Create programs to automatize repeating settings, tests, and measurements. The instrument is connected to a computer running the program.

This way of operation is described in [chapter 21, "Remote Control"](#), on page 634.

Remote operation (Windows 7)

The remote desktop connection of Windows Embedded Standard 7 can be used for instrument control and file transfer. Even on computers with non-Windows operating systems a remote desktop connection is possible using RDP-applications.

Remote operation (Windows XP)

The Remote Desktop Connection of Windows XP is not supported for instrument control. Remote Desktop can only be used for file transfer from and to the instrument.

Remote monitoring and control of the instrument from a connected computer is possible with a standard web browser and the common cross-platform technology Virtual Network Computing (VNC). You have to install the VNC server on the R&S RTO. Installation and configuration is described in the Application Note "Remote Monitoring and Control of the R&S RTO with a Web Browser", available on the Rohde & Schwarz Internet.

2.4.1 Means of Manual Interaction

The R&S RTO provides the following means of manual interaction, which you can use alternatively or complementary:

- Touchscreen:
Using the touchscreen is the most direct interaction way. Use your finger to place waveforms on the screen, mark areas for zoom and histograms, set parameters in dialog boxes, enter data, and much more. Most of the control elements and actions on the screen are based on the Windows concept, and you will easily become familiar with the user interface.
Tapping the screen works like clicking mouse buttons:
 - Tap = click: Selects a parameter or provokes an action.
 - Double-tap = double-click has the same effect as touch and hold = right-click: Opens the on-screen keyboard or keypad, or a specific editor if available
- Function keys and rotary knobs:
The front panel provides nearly all functions and controls to operate the instrument in the classic ways, without touchscreen. As an exception, the signal bar cannot be used with front panel controls.
- Optional mouse and/or keyboard:

These devices work conform to Microsoft standards on the screen. The navigation keys on the front panel correspond to the keys on the keyboard.

The usage of the touchscreen and navigation keys is described in detail in the following sections.

2.4.2 Information on the Display

The touchscreen display of the instrument shows not only waveforms and measurement results, but also information and everything you need to control the instrument. All waveform-related display elements are shown in [figure 2-4](#). An overview of control elements - like dialog box, toolbar - is given in [chapter 2.2.1.1, "Touchscreen Display"](#), on page 26.

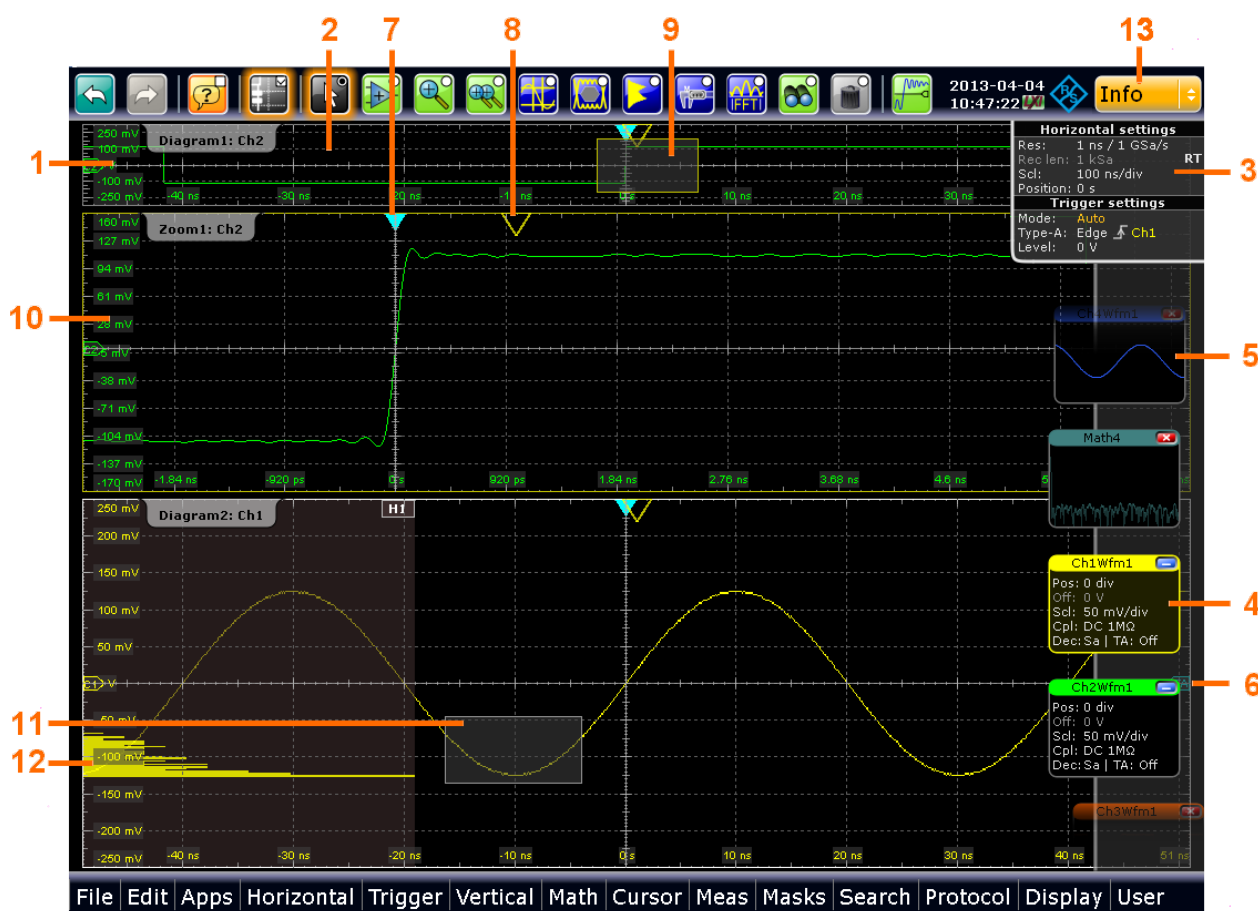

Fig. 2-4: Display information

- 1 = Diagram
- 2 = Grid
- 3 = Horizontal and trigger label
- 4 = Signal icon with main vertical and acquisition settings
- 5 = Signal icon with minimized live signal view
- 6 = Trigger level
- 7 = Trigger position
- 8 = Reference point (rescaling center)
- 9 = Zoom area

- 10 = Zoom diagram
- 11 = Histogram area
- 12 = Histogram
- 13 = Messages

Diagrams

A diagram shows one or more waveforms: channel, reference, and math waveforms together with histograms, masks etc. Zoom details appear in separate zoom diagrams, also XY-waveforms appear in separate diagrams.

By default, the diagram name contains the diagram number and the short names of the waveforms shown inside. To change the diagram name, touch and hold the tab name. The on-screen keyboard opens to enter the new name. Names must be unique.

To arrange the diagrams on the screen, the Rohde & Schwarz SmartGrid function helps to find the target place simply and quickly. A tabbed view is also possible, and you can adjust the diagram size.

For details, see ["To arrange a waveform using the SmartGrid"](#) on page 79.

Grid

The grid shows the vertical and horizontal divisions. The division lines are labeled with the correspondent values. The grid labels have the color of the waveform to which they belong. If several waveforms are shown in one diagram, the grid has the color of the selected waveform.

Horizontal and trigger labels

The horizontal and trigger labels on the signal bar show the current time base and trigger settings. If you double-tap a label, the relevant dialog box opens with the tab used at last.

Signal icons on the signal bar

Each waveform is represented by a signal icon. For an active waveform, that is shown in a diagram, the signal icon displays the signal label with the main vertical and acquisition settings for the waveform. The icon can also display a signal view, that is the minimized live waveform.

You can place the signal bar on the left or right side of the screen, hide it, and change the color and transparency of the bar.

In [figure 2-4](#), the signal icons Ch1Wfm1 and Ch2Wfm1 show the signal label, and the waveforms are displayed in diagrams. All other waveforms are minimized and shown in the signal view.

Trigger position and trigger level

The blue markers show the horizontal position of the trigger and the vertical trigger level. You can tap and move the trigger markers in the diagram to set the positions graphically. The trigger point is the zero point of the diagram.

Reference point

The reference point marks the horizontal position of rescaling center. If you modify the time scale, the reference point remains fixed on the screen, and the scale is stretched or compresses to both sides of the reference point.

You can define the position of the reference point on the screen, and its time distance from the trigger point of the diagram.

Zoom diagram and zoom area

Zoomed waveforms are shown in separate zoom diagrams, additionally to the waveform diagrams. On the original waveform diagram, a rectangle indicates the zoomed section of the waveform - this is the zoom area. You can modify the zoom area by dragging the rectangle as a whole, and by dragging its sides - tap the zoom area to toggle between these modes. Furthermore, you can set exact positions.

The frames of the zoom area and the associated zoom diagram have the same color, several zooms are marked with different colors. So it is easy to assign zoom area and zoom diagram.

As for waveform diagrams, you can change the name of the zoom diagram. A zoom in a zoom and coupled zooms are also possible.

All zooming possibilities are described in detail in the "User Manual", chapter "Zoom".

Histogram and histogram area

A histogram shows the frequency of occurrence of voltage or time values in a bar chart directly in the diagram. The rectangular histogram area indicates the part of the waveform that is considered in the histogram. The vertical histogram counts the voltage values, and the horizontal histogram counts time values. You can switch between vertical and horizontal mode, and modify the histogram area by dragging the rectangle as a whole, by dragging its sides, or by setting exact positions.

Messages

A yellow or red Info button on the toolbar points to the status messages of the instrument. You can open the message box by tapping the button. See also: [chapter 2.4.9, "Messages"](#), on page 86.

2.4.3 Using the Toolbar

The toolbar provides direct access to important control and measurement functions, it shows current date and time, and an information box with status messages of the instrument.

2.4.3.1 Toolbar Functions

Using the toolbar is easy and straightforward.

1. Tap the icon to activate the function.
2. For analyzing functions, tap the required diagram, or drag a rectangle on the diagram to mark the area to be analyzed.



You can remove redundant icons and the date/time display from the toolbar with "Display" menu > "Toolbar".



The following description of the toolbar functions provides more details.



Undo

Undoes the last setting actions step by step. Some actions cannot be revoked: locking the touchscreen with T-SCREEN LOCK, changing the trigger MODE (auto/normal), save and recall, and finishing the mask definition with the "Select" icon.



Redo

Recovers the undo steps in reverse order.



Show tooltips and help

Enables the tooltip display. A short description appears when you tap a parameter in a dialog or result box. To open the corresponding help topic in the online help, tap the "Show Help" button in the lower right corner of the tooltip. See also: [chapter 2.4.10](#), "Getting Information and Help", on page 87.



Show signal bar

Shows and hides the signal bar.

The look and the behavior of the signal bar can be configured, see [chapter 2.4.6](#), "Using the Signal bar", on page 81.



Select

Enables the select mode to move and modify objects on the touchscreen. The select mode is activated automatically when an analyzing function is completed.



Hardware zoom

Changes the instrument settings - horizontal and vertical scales as well as trigger level and offset - to display a part of the diagram in greater detail.



Zoom

Displays a magnified section of the diagram in an additional zoom diagram. It is a display zoom, instrument settings are not changed.

Touch and hold the zoom area to open the "Zoom" dialog box.

Remote command:

[LAYout:ZOOM:ADD](#) on page 762



Coupled zoom

Creates a coupled zoom area and its related zoom diagram. If you change the size of one zoom area, the size of all coupled zoom areas is changed as well.

Remote command:

[LAYout:ZOOM:ADDCoupled](#) on page 762



Cursor

Displays vertical and horizontal cursors and performs a cursor measurement.

Tap the icon and then tap the diagram where you want to set the cursors, or draw a rectangle in the diagram to position the cursor lines. The resulting cursor lines measure the selected waveform. The results appear in the "Cursor Results" box. You can adjust the cursor source, type and position in the result box. Move the cursor lines by dragging them in the diagram, or by turning the navigation knob. Pressing the knob switches the parameter to be changed.



Masks

Starts the on-screen mask definition and the testing against the defined mask.

Tap the icon and then tap the points that build the mask. Double-tap the last point to finish mask definition. Now you can move the mask on the screen.

To configure the mask test settings, tap the  icon in the "Mask" result box.



Vertical histogram

Enables the histogram mode to create a vertical histogram.

Tap the icon and then drag a rectangle on the diagram to mark the histogram area. The vertical histogram for the selected waveform appears.

Touch and hold the histogram area to open the "Histogram" dialog box.



Horizontal histogram

Enables the histogram mode to create a horizontal histogram.

Tap the icon and then drag a rectangle on the diagram to mark the histogram area. The horizontal histogram for the selected waveform appears.

Touch and hold the histogram area to open the "Histogram" dialog box.

Note: By default, this icon is not visible. You can add it to the toolbar, see [chapter 2.4.3.2, "Configuring the Toolbar"](#), on page 77.



Measurement

Starts the *default* measurement for the selected waveform and displays the "Measurement" result box.

Tap the icon and then tap the diagram with the waveform to be measured.

To configure the measurement or select a different measurement type, tap the  icon in the "Measurement" result box.

To recall a previously configured measurement, do not use the "Measurement" icon, but rather the "Meas > Setup" menu item.



FFT

Transforms a waveform to the frequency spectrum by fast Fourier transformation (FFT). The FFT trace appears in a new diagram.

Tap the icon and then tap diagram with the waveform to be transformed. The FFT diagram is created from the selected waveform.

To configure FFT settings, double-tap the FFT diagram.



Search

Performs a search according to the settings in the "Search Setup" dialog box. The search results appear on the screen.

Tap the icon and then tap diagram with the waveform to be searched. The search is performed on the selected waveform.



Delete

Removes zoom and histogram areas and their associated diagrams; measurement areas and their associated results; and mask segments. The icon also switches off a waveform.

Tap the icon and then tap the area or diagram to be deleted, or the waveform to be switched off.



Find level

Analyses the signal and sets the trigger level to the middle of the signal peaks.

2.4.3.2 Configuring the Toolbar

You can configure which icons are visible on the toolbar and which are hidden, so that only the ones you use are displayed. Furthermore, you can define whether the current date and time are displayed on the toolbar.

1. On the "Display" menu, select "Toolbar".
2. For each icon you want to use, select the "Visible" option.
To display all available icons, tap "Show All".
To hide all available icons, tap "Hide All".
3. Enable the "Show date and time" option to display the current date and time on the toolbar.

2.4.4 Working with Waveforms

The R&S RTO can create and display several types of waveforms:

- Channel waveforms:
Up to three waveforms per input channel can be shown. For a four-channel instrument, 12 channel waveforms are available.
- Reference waveforms:
Four waveforms can be used as reference for comparison and analysis.
- Math waveforms:
Four mathematic waveforms can be created with mathematic operations performed on channel, reference, and other math waveforms.
- Zoom waveforms:
Show the details of a waveform.
- XY-waveforms:
Four XY-waveforms can be created. Each XY-waveform is built from the voltage values of two source waveforms.
- Digital waveforms:
The Mixed Signal Option R&S RTO-B1 provides 16 digital channels grouped in two logic probes (pods) with 8 channels each.

Waveform handling

With R&S RTO, a large number of waveforms can be used for signal analysis. To handle this multitude while keeping track of it, the R&S RTO provides intelligent support:

- The color system helps to distinguish the waveforms. The color of the vertical rotary knobs indicates the signal that is focused (selected). The color of each waveform can be changed, the color of its signal icon and of the illuminated keys is adjusted to the new color. Alternatively, a color table can be assigned to a waveform. Settings: DISPLAY > "Signal Colors / Persistence" tab.
- Waveforms can be minimized to signal icons showing a small real-time signal view. Thus, more space in the diagram area is available without switching waveforms off.
- Diagrams are displayed on tabs – you can arrange them side by side or one above the other. To change the diagram name, touch and hold the tab name. The on-screen keyboard opens to enter the new name.
- The Rohde & Schwarz SmartGrid function helps to arrange the diagrams when dragging a signal icon to the diagram area.

Waveform states

Depending on its place on the screen and the effect of settings, a waveform has one of the following states:

- Off
- Active: The waveform is shown in a diagram
- Minimized: The waveform is shown as real-time signal view in its signal icon
- Selected: One of the active waveforms that has the focus. In each diagram, one of the assigned waveforms is selected – it appears "on top" in the diagram, and the grid labels have the color of the selected waveform. Some of the toolbar functions, like cursor and histogram measurements are performed on the selected waveform. All waveform-specific settings are applied to the selected waveform of the selected diagram. The vertical POSITION and SCALE knobs, and the SIGNAL OFF key are illuminated with the color of the selected waveform.

In [figure 2-4](#), "Ch1Wfm1" is the selected waveform: The frames of the diagram and the signal icon are highlighted.

To switch a waveform on

A channel waveform is activated as soon as you connect the probe. You can switch it on and off according to your needs.

- ▶ Choose on of the following ways:
 - Press the channel key.
 - In the "Vertical" dialog box, tap the "Enable" icon of the waveform.



The waveform is now active and appears in the diagram.

To select a waveform

- ▶ Choose on of the following ways:

- Tap the waveform in the waveform diagram.
- To select a channel, reference, or math waveform, press the corresponding key.
- Tap the signal icon. This works only if the "Click on signal icon" setting is set to "Hardkey logic", see ["To set the action on tapping the signal icon"](#) on page 82.

Note: Zoom waveforms in zoom diagrams cannot be selected.

To minimize a waveform

- ▶ Choose on of the following ways:
 - Tap the "Minimize" icon in the upper right corner of the waveform's signal label in the signal bar.
 - Drag the waveform from the diagram to the signal bar.
 - Tap the signal icon (depends on the "Click on signal icon" setting, see ["To set the action on tapping the signal icon"](#) on page 82).

The waveform disappears from the diagram and the minimized signal view is shown in the signal icon.

Tip: To set the waveform back to its previous diagram, use "Undo".

To arrange a waveform using the SmartGrid

You can arrange waveforms in one of the existing diagrams, or in a new diagram.

1. Drag the signal icon to the diagram area.
The Rohde & Schwarz SmartGrid appears and a blue area shows where the waveform will be placed.
2. Drop the waveform in the target area.
The waveform appears in an existing or in a new diagram and it is selected for further actions.

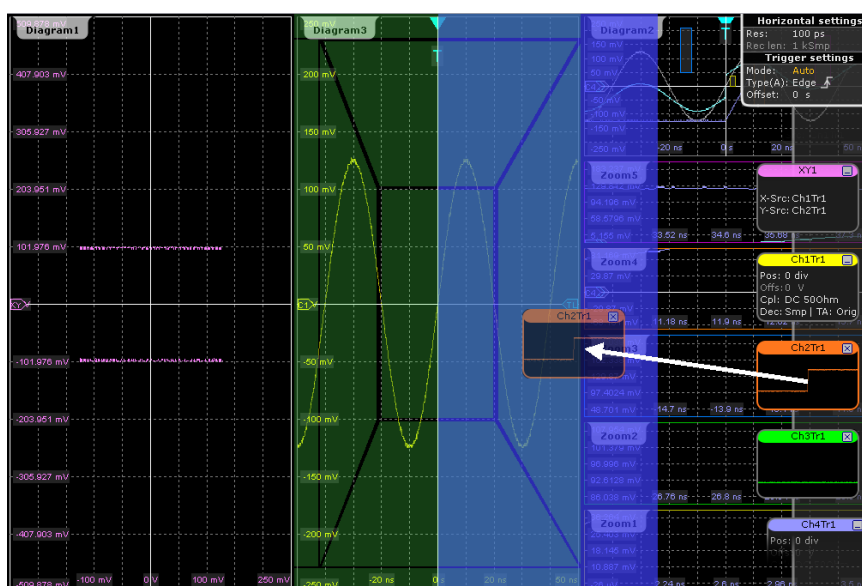

- To change the size of the new diagram, drag its edge to the required position.



The diagram layout depends on the position where you drop the signal view, in relation to an existing diagram.

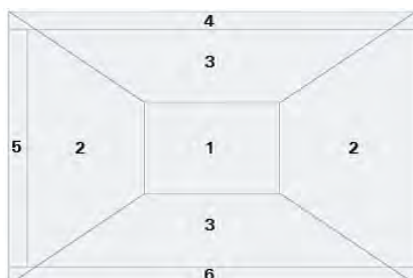

Fig. 2-5: SmartGrid positions

- 1 = In the existing diagram, overlay of signal
- 2 = New diagram on the left or right
- 3 = New diagram above or below
- 4 = New diagram on top of the existing diagram
- 5 = XY-diagram
- 6 = YX-diagram

To switch off a waveform

- ▶ Do one of the following:
 - Select the waveform, and then press the SIGNAL OFF key.
 - To switch off a minimized waveform, tap the "Close" icon in the upper right corner of the minimized signal view.
 - Disable the "Show channel" setting in the "Vertical" dialog box.
 - Tap the "Delete" icon (Recycle bin) in the toolbar, and then the waveform. If several waveforms overlap or lie close together, the upper (selected) waveform is switched off.

2.4.5 Displaying Results

The results of automatic or cursor measurements, mask tests, and searches are displayed immediately, either in a result box in front of the diagrams or in a result icon on the signal bar. You can select the default position. Similar to waveform diagrams, you can minimize a result box to a result icon, and display the results in a separate diagram on the screen.

To configure the result box display

- Tap the "Minimize" icon in the floating result box.
The result box is closed, and a result icon with the result values is added to the signal bar.
- Drag the result icon from the signal bar to the diagram area and drop it in the dedicated target area, as you would do with a waveform.

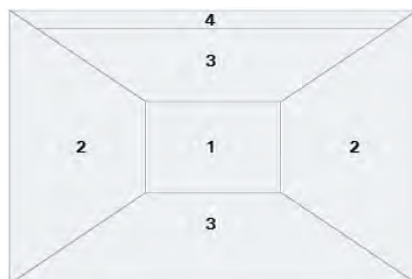

- 1 = Floating result box
- 2 = Table in a diagram on the left or right
- 3 = Table in a diagram above or below
- 4 = New tab in existing diagram

The results are displayed in the specified area of the screen.

3. To move the result table back to the signal bar, tap the tab name and drag it back to the signal bar.

To open the setup dialog box

- ▶ In the result box, tap the  icon.
The dialog box with corresponding settings opens.

To define the default position of results

1. Press the DISPLAY key on the front panel.
2. In the "Display" dialog box, select the "Diagram Layout" tab.
3. Under "Result box", select the "Default position":
 - "Preview": result icon on the signal bar
 - "Floating": movable result box in front of the diagrams

2.4.6 Using the Signal bar

The signal bar can hold a large number of signal and result icons. Signal icons represent the waveforms, serial buses and parallel buses, while result icons are minimized result boxes showing measurement and search results.

To scroll the signal bar

If the signal bar contains more than five icons, not all icons are visible on the display.

- ▶ Touch one of the icons and move it up or down until the required icon appears.

To switch on and off the signal bar

If you need the complete screen to see the diagrams and results, you can switch off the signal bar completely.

- ▶ Tap the "Show Signal Bar" icon on the toolbar.



Alternatively, tap "Signal Bar" on the "Display" menu.

To change the position of the signal bar

- ▶ Touch the horizontal and trigger label on the top and drag the signal bar to the opposite side of the screen.

To set the action on tapping the signal icon

You can define what happens when you tap a signal icon: Either the waveform is minimized, or selected (get the focus).

1. Press the DISPLAY key on the front panel.
2. In the "Display" dialog box, select the "Diagram Layout" tab.
3. Under "Signal bar", tap "Click on signal icon".
4. Select the action on clicking/tapping:
 - "Minimize": The waveform switches from the diagram to the signal icon and is shown as small real-time preview.
 - "Hardkey logic": Selects the waveform for further operation.

To configure auto-hide

The signal bar can be hidden if the displayed information has not changed for a defined time, and is displayed again automatically when a setting in the signal bar changes. The signal bar is not hidden entirely, it simply fades and becomes less visible in the display.

1. Press the DISPLAY key on the front panel.
2. In the "Display" dialog box, select the "Diagram Layout" tab.
3. Select "Auto-hide".
4. Define the hiding properties:
 - "Hide bar after": the time after which the bar is hidden if no changes occur
 - "Hiding opacity": Opacity of the hidden signal bar on a scale from 30% (high transparency) to 80% (lower transparency and better visibility)
 - Hide head also: the horizontal and trigger labels are also faded

To change the colors

If you want to highlight the signal bar, you can change the "Fill color" and "Border color" of the bar.

1. Press the DISPLAY key on the front panel.
2. In the "Display" dialog box, select the "Diagram Layout" tab.

3. Tap "Border color" to change the color of the signal bar frame, or "Fill color" to change the fill color of the bar.
4. In the "Adjust Colors" dialog box, select the color to be used.
5. To use a color that is not yet defined, tap "Userdefined Colors" and define the new color settings. To see the effect of a setting change in the Preview area, enter the value and press the ENTER key.
6. Tap "OK."

The signal bar is displayed in the new colors.

2.4.7 Accessing the Functionality

All functionality is provided in dialog boxes as known from computer programs. You can control the instrument intuitively with the touchscreen. This section provides an overview of the accessing methods.



For direct access to important control and measurement functions use the toolbar, see [chapter 2.4.3, "Using the Toolbar"](#), on page 74.

To open a dialog box

- ▶ Perform one of the following actions:
 - Tap the required menu, and then the menu entry.
 - Press the function key on the front panel.
 - If a results box is open, tap the  icon to open the corresponding dialog box.
 - Touch and hold the signal icon to open the corresponding "Vertical" dialog box. For XY-waveforms, the "XY Diagram" tab opens.
 - Touch and hold the horizontal or trigger label to open the "Horizontal" or "Trigger" dialog box, respectively.

To close a dialog box

- ▶ Tap the "Close" icon in the upper right corner.
Or:
Press the ESC key on the front panel.

To select an option in a dialog box

- ▶ Tap the required option.
Or:
Press the FIELD LEFT and FIELD RIGHT keys to navigate to the required option and then press the CHECKMARK key.

To select an option in a list

If many options are available - for example, for the trigger type - the options are provided in a list. The current selection is shown on the list button.

- ▶ Tap the list button, and then tap the required option.
- Or:
- Use the front panel keys:
 - a) Press the FIELD LEFT and FIELD RIGHT keys to navigate to the list button.
 - b) Press the CHECKMARK key to open the list.
 - c) Press the UP ARROW and DOWN ARROW keys to navigate to the required option in the list.
 - d) Press the CHECKMARK key to select the marked option.

To find a setting by its name

If you are looking for a specific setting or function and do not know in which dialog box it is located, you can search for it.

1. On the "Edit" menu, tap "Find".
2. Tap the keyboard icon beneath the "Search for" field, and enter the search term.

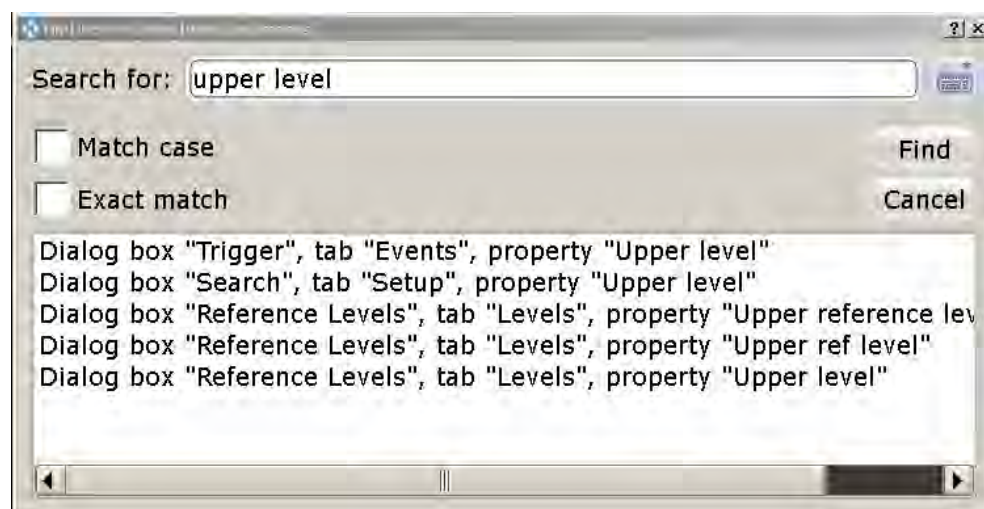

3. Tap a dialog box in the list to open it in the background.

Tip: The required setting may be invisible if other settings do not fit. For example, the settings of the windows trigger type are only visible if the "Windows" trigger is selected. In this case, a message "Item currently not visible" is shown.

2.4.8 Entering Data

Most important parameters have their own rotary knobs on the front panel. The parameters on the POSITION and RESOLUTION / RECORD LENGTH keys can be toggled by pressing the knob. When you press or turn a knob, the input box appears with the parameter name and current value.

For data input in dialog boxes, the touchscreen provides an on-screen keypad to enter numeric values and units. For text input, the on-screen keyboard with English key layout is used.

Using rotary knobs

1. Turn the knob to change the value.
2. Tap the "Steps" icon to toggle the increment.
3. Tap the "Auto" icon to set the parameter to the autoset value if available.



To enter values with the on-screen keypad

1. Double-tap the entry field to open the on-screen keypad.



2. Enter the numeric value:
 - a) Tap the "Inc" button to increase the displayed value in fixed steps, or "Dec" to decrease the value. To toggle between small steps and large steps, tap the "Steps" icon.



Tap "Auto" to use the default value, if available.

Tap "Cur" to use the currently defined value, that is, the value that was used before the keypad was displayed.

- b) Tap the arrow buttons to move the cursor left or right.
Tap "Bksp" to delete the last character before the cursor.
- c) Tap ± to change the sign of the value.

3. Tap the unit button to complete the entry.

To enter data with the on-screen keyboard

1. If it is not opened automatically, double-tap an entry field to open the on-screen keyboard.



2. Enter the text as you would on a normal keyboard.
 - Tap "Caps" to enter a series of capitals, or tap "Shift" to enter one capital character.
 - Tap "Cur" to use the currently defined value, that is, the value that was used before the keyboard was displayed.
 - Tap the arrow buttons to move the cursor left or right.
 - Tap "Bksp" to delete the last character before the cursor.
3. Tap "Enter" to complete the entry.

To enter numeric data in a dialog box with navigation controls

1. Press the FIELD LEFT and FIELD RIGHT keys to navigate to the entry field.
2. To change the value with a small step size, turn the rotary knob. Alternatively, press the UP ARROW and DOWN ARROW keys for a larger step size.

If you edit numeric data in tables, the entry field must be in edit mode: Press ENTER, or the CHECKMARK key, or the navigation rotary knob to activate the edit mode.

2.4.9 Messages

Status messages of the instrument are displayed for a few seconds, then they are shown in a message box in the upper right corner of the screen. By default, the message box is closed. You can open it to read the messages and to delete them.



- ▶ Tap the yellow "Info" button to open and close the message box.

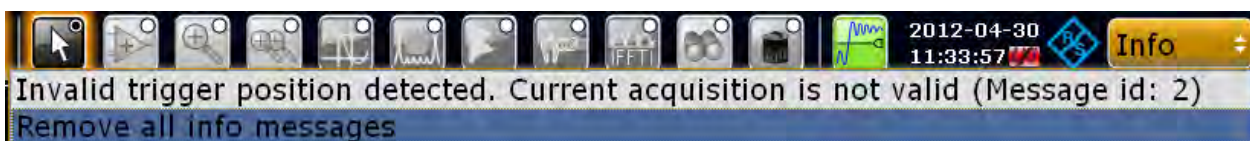

If no messages are available, the "Info" button is hidden.

Important messages are indicated by a red "Info" button. These messages cannot be deleted, they remain until the problem is solved.

2.4.10 Getting Information and Help

In many dialog boxes, graphics are included to explain the way a setting works. For further information, you can use the following sources:

- Tooltips give a short description of the parameter.
- The context help provides functional description on a setting, and the corresponding remote command.
- The general help explains a dialog box, provides instructions, and general information.

2.4.10.1 Displaying Help

To display tooltips and context help

1. Enable the "Tooltip" icon on the toolbar.



2. Tap the parameter for which you need information.
The tooltip opens.
3. To open the corresponding help topic, tap the "Show Help" button in the lower right corner of the tooltip.

The "Help" window opens and displays the comprehensive description and the corresponding remote command. You can browse the help for further information.

Note: With touchscreen, the tooltip display disables automatically when you tap a parameter. To show another tooltip, tap the tooltip icon again. If you use a mouse, the tooltip display remains on until you switch it of. The tooltip appears when you move the mouse on a parameter.

To open general help

- ▶ Press the yellow HELP button on the left side of the screen.

If a dialog box is open, the help topic for the current tab is shown. Otherwise the "Contents" page appears.

2.4.10.2 Using the Help Window

The Help window contains several tabs:

- "View" - shows the selected help topic
- "Contents" - contains a table of help contents

- "Index" - contains index entries to search for help topics
- "Search" - provides text search



The Help toolbar provides some buttons:

- To browse the topics in the order of the table of contents: Up arrow = previous topic, Down arrow = next topic
- To browse the topics visited before: Left arrow = back, Right arrow = forward
- To increase or decrease the font



To navigate the Help, use the touchscreen. Alternatively, you can also use the navigation keys on the front panel.

To search for a topic in the index

The index is sorted alphabetically. You can browse the list, or search for entries in the list.

1. Switch to the "Index" tab.
2. Select the "Keyboard" icon besides the entry field.
3. Enter the first characters of the keyword you are interested in.
The entries containing these characters are displayed.
4. Double-tap the suitable index entry.
The "View" tab with the corresponding help topic is displayed.

To search topics for a text string

1. Switch to the "Search" tab.
2. Select the "Keyboard" icon besides the entry field.
3. Enter the string you want to find.
If you enter several strings with blanks between, topics containing all words are found (same as AND operator).

For advanced search, consider the following:

- To find a defined string of several words, enclose it in quotation marks. For example, a search for *"trigger qualification"* finds all topics with exactly *"trigger qualification"*. A search for *trigger qualification* finds all topics that contain the words *trigger* and *qualification*.
- Use "Match whole word" and "Match case" to refine the search.
- Use operators AND, OR, and NOT.

To close the Help window

- ▶ Select the "Close" icon in the upper right corner of the help window.

Or:
Press the ESC key on the front panel.

3 Acquisition and Setup

This chapter describes the horizontal and vertical settings as well as the acquisition and probe setup.

3.1 Basics

This chapter provides background information on the essential settings in the vertical and horizontal systems, on acquisition setup and probing.

3.1.1 Vertical System

The controls and parameters of the vertical system are used to scale and position the waveform vertically.

3.1.1.1 Input coupling

The input coupling influences the signal path between input connector and the following internal signal stage. The coupling can be set to DC, AC, or ground.

- DC coupling shows all of an input signal. DC coupling is available with 1 M Ω input impedance to connect standard passive probes. DC coupling is the default for 50 Ω input impedance.
- AC coupling is useful if the DC component of a signal is of no interest. AC coupling blocks the DC component of the signal so that the waveform is centered around zero volts.
- Ground coupling disconnects the input signal from the vertical system to see the ground level (zero volts) on the screen. Ground coupling is useful for reference purposes.

3.1.1.2 Vertical scale and position

Vertical scale and vertical position directly affect the resolution of the waveform amplitude. The vertical scale corresponds to the ADC input range. To get the full resolution of the ADC, waveforms should cover most of the height of the diagram.

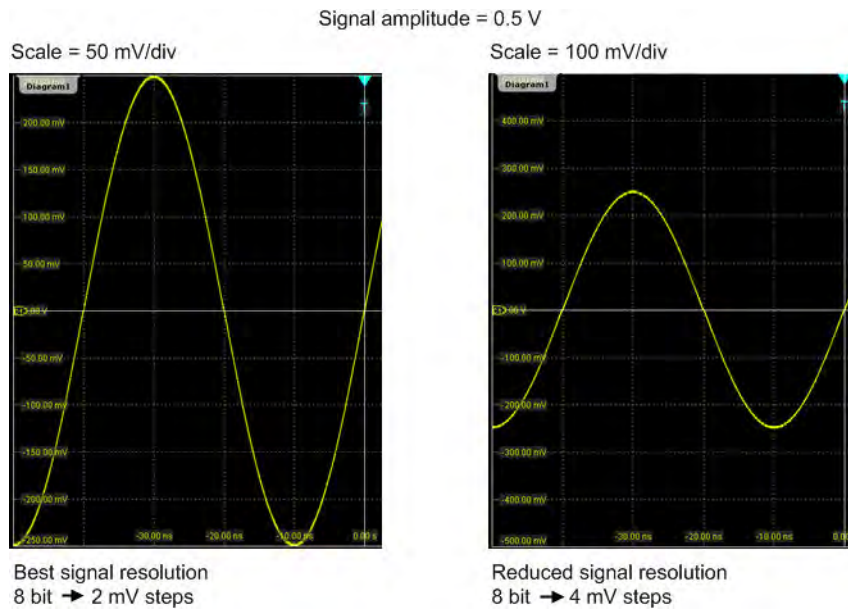

Fig. 3-1: Input range and resolution of the ADC

With R&S RTO, you can work with multiple diagrams, and each diagram obtains the full vertical resolution, no matter where the diagram is placed. Therefore, use a separate diagram for each waveform instead of the traditional setup that arranges the waveforms side by side in one diagram.

Signal amplitude: 0.5 V
Scale/div = 100 mV/div
Reduced signal resolution: 4 mV steps

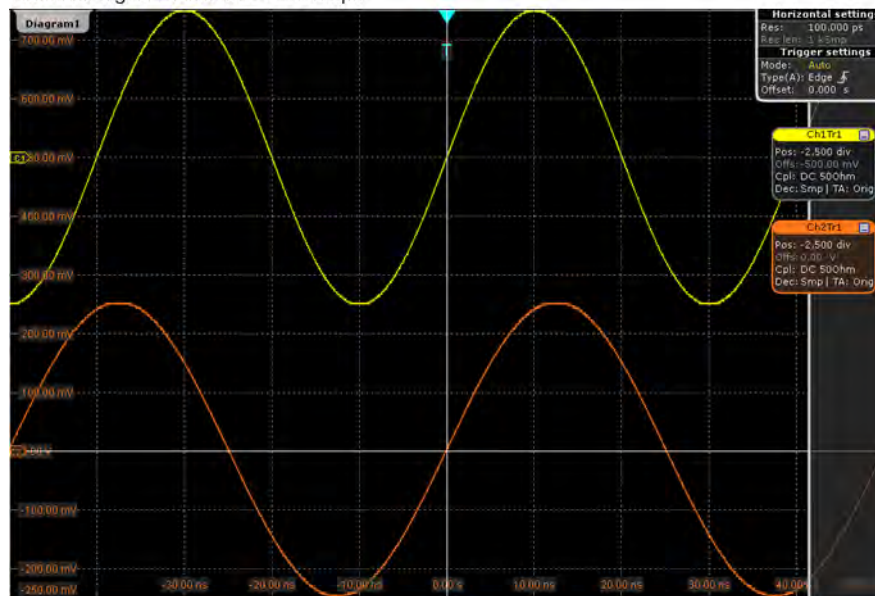

Fig. 3-2: Traditional setup of multiple waveforms in one diagram: reduced resolution

Signal amplitude: 0.5 V
 Scale = 50 mV/div
 Best signal resolution: 2 mV steps

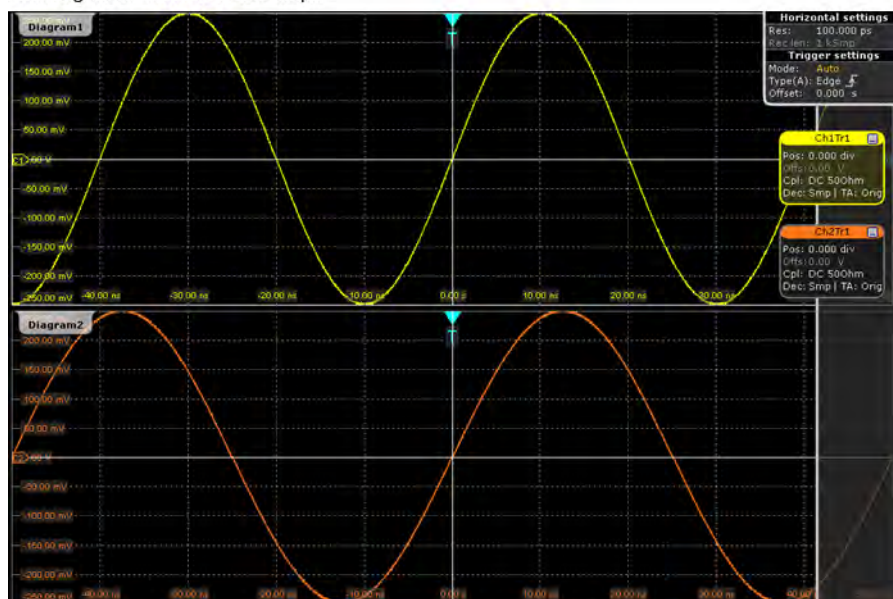

Fig. 3-3: R&S RTO setup of multiple waveforms in separate diagrams: best resolution

3.1.1.3 Bandwidth

For analog applications the highest signal frequency determines the required oscilloscope bandwidth. The oscilloscope bandwidth should be slightly higher than the maximum frequency included in the analog test signal to measure the amplitude with very little measurement error.

Most test signals are more complex than a simple sine wave and include several spectral components. A digital signal, for example, is built up of several odd harmonics. As a rule of thumb, for digital signals the oscilloscope bandwidth should be 5 times higher than the clock frequency to be measured.

The oscilloscope is not a stand-alone system. You need a probe to measure the signal of interest, and the probe has a limited bandwidth, too. The combination of oscilloscope and probe creates a *system bandwidth*. To maintain the oscilloscope bandwidth, that is, to reduce the effect of the probe on the system bandwidth, the probe bandwidth should exceed the bandwidth of the oscilloscope, the recommended factor is 1.5 x oscilloscope bandwidth.

See also: [chapter 3.1.4.1, "Voltage Probes"](#), on page 98

3.1.2 Sampling and Acquisition

The vertical system of a digital oscilloscope conditions the test signal in a way that the following A/D Converter (ADC) can transform the measured voltage into digital data.

3.1.2.1 Sampling and Processing

The A/D converter samples the continuous signal under test at specific points in time and delivers digital values called **ADC samples**. The rate at which the converter is working is the **ADC sample rate**, a constant value usually specified in GHz: $f_{ADC} = 1 / T_I$

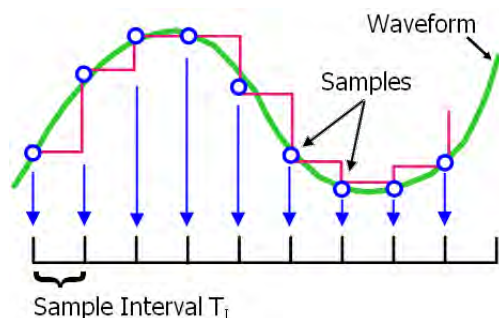

The digital ADC samples are processed according to the acquisition settings. The result is a waveform record that contains **waveform samples** and is stored in the **waveform memory**. The waveform samples are displayed on the screen and build up the waveform.

The number of waveform samples in one waveform record is called **record length**, and the rate of recording waveform samples - the number of waveform samples per second - is the **sample rate**. The higher the sample rate, the better is the resolution and the more details of the waveform are visible.

Maximum sample rate on R&S RTO1044

R&S RTO1044 can work with double maximum realtime sample rate compared to other R&S RTO instruments. This high sample rate is achieved by interleaving two channels: channel 1 and 2 are interleaved, and also channel 3 and 4. Interleaving assumes that only one of the paired channels can be used - either channel 1 or channel 2, and either channel 3 or 4.

Using a channel on R&S RTO oscilloscopes is more than displaying it. In the background, without displaying the channel, it can serve as trigger source, as source of a math waveform, cursor or automatic measurement. As soon as the second channel of a pair is used in one way or another, the interleaving mode is disabled and the realtime sample rate is limited to the usual value of 10 GSa/s.

See also: "[Waveform display](#)" on page 106

Minimum sample rate and aliasing

A sufficient resolution is essential for correct reconstruction of the waveform. If the signal is undersampled, aliasing occurs - a false waveform is displayed. To avoid aliasing and accurately reconstruct a signal, Nyquist theorem postulates that the sample rate must be at least twice as fast as the highest frequency component of the signal. However, the theorem assumes ideal conditions, so the Nyquist sample rate is usually not sufficient.

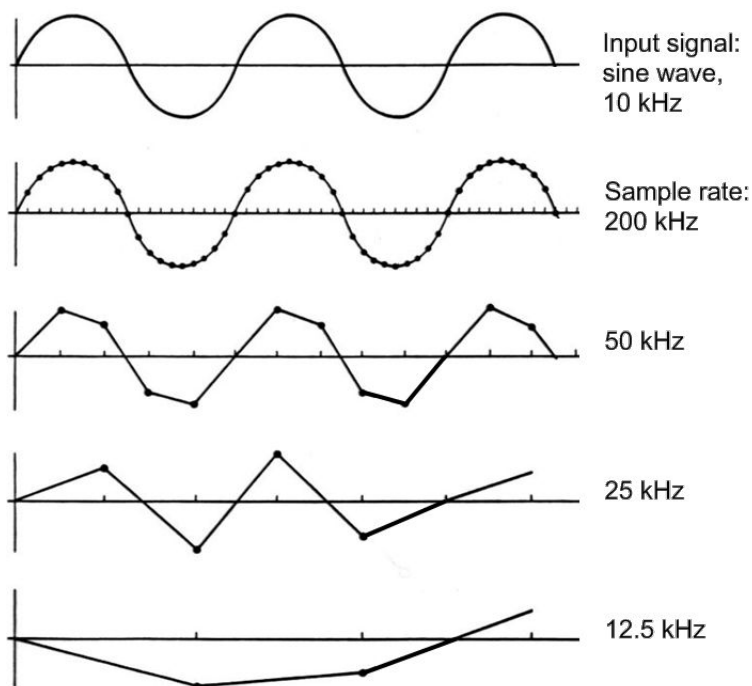

Fig. 3-4: Waveforms acquired with different sample rates

This means that the sample rate must be set to a value 3 to 5 times the fastest frequency component of the signal. A higher sample rate increases signal fidelity, increases the chance to capture glitches and other signal anomalies, and improves the zoom-in capabilities.

3.1.2.2 Acquisition Settings

The sample rate can be the same as the constant ADC sample rate, or higher, or lower. To get a higher sample rate, methods of **resolution enhancement** are used: interpolation and equivalent time sampling. To reduce the sample rate, **decimation** methods help: sample, peak detect, high resolution and RMS.

As digital waveform data is stored in the memory, and the memory can save many waveform records, further **waveform arithmetic** processing is possible: average and envelope waveforms are resulting waveforms, created from a composite of sample points taken from multiple acquisitions.

The R&S RTO provides the following acquisition features:

- You can combine resolution enhancement and waveform decimation modes with waveform arithmetic.
- You can display up to three waveforms from one input signal and apply different decimation and arithmetic to each waveform.

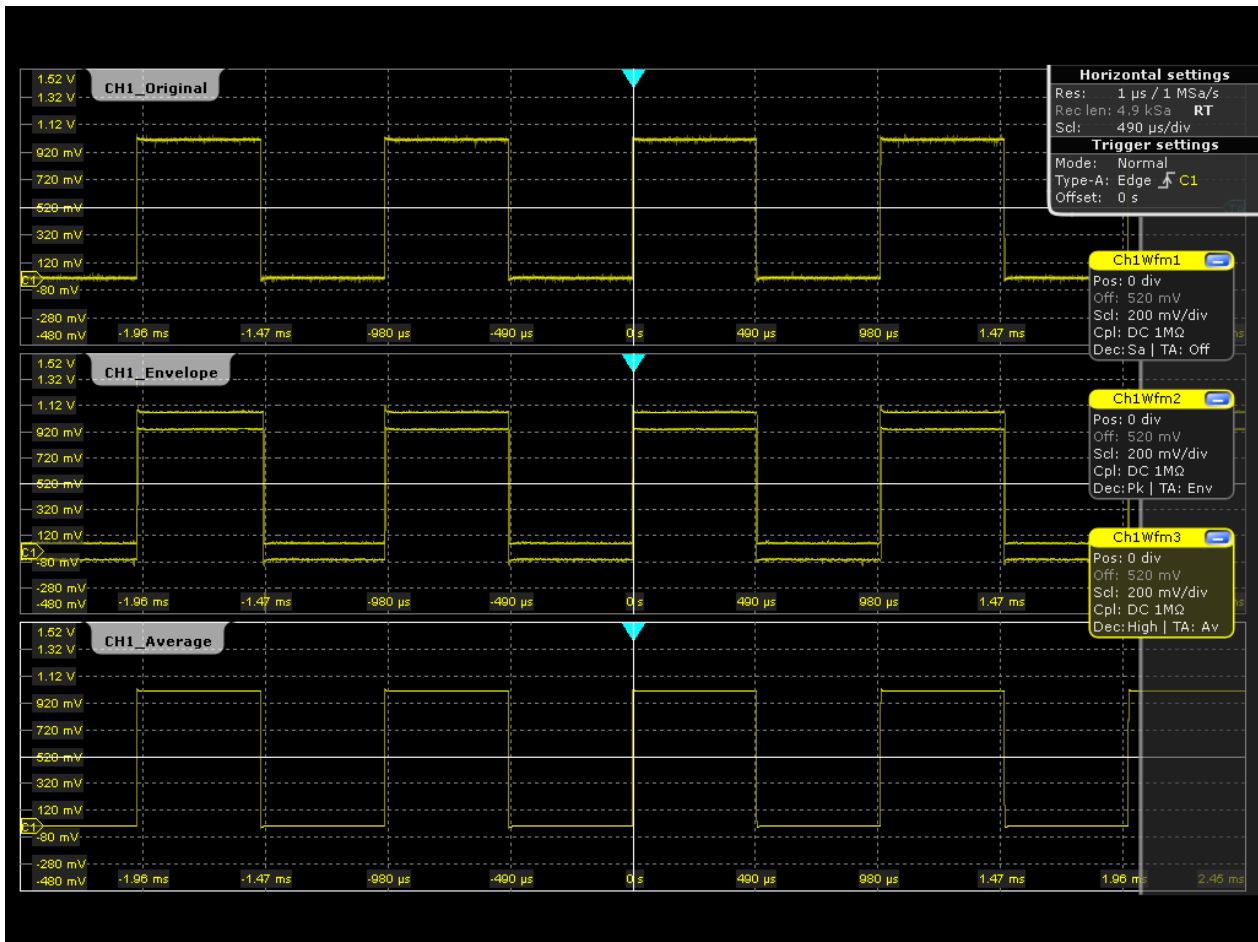

3.1.2.3 Acquisition Control

You can run the R&S RTO in two ways:

- Continuous: the instrument acquires data until you stop it manually.
- NxSingle: the instrument samples and processes a specified number of acquisitions.

The determining point of an acquisition is the trigger. The instrument acquires continuously and keeps the sample points to fill the pre-trigger part of the waveform record. When the trigger occurs, the instrument continues acquisition until the post-trigger part of the waveform record is filled. Then it stops acquiring and waits for the next trigger. When a trigger is recognized, the instrument will not accept another trigger until the acquisition is complete.

The trigger modes define how the instrument triggers:

- Normal: The instrument acquires a waveform only if a real trigger occurs, that is, if all trigger conditions are fulfilled.
- Auto: The instrument triggers repeatedly after a fixed time interval if the trigger conditions are not fulfilled. If a real trigger occurs, it takes precedence. If the real trigger is faster than the auto trigger, both modes are virtually the same.

In practice, both trigger modes are useful: The auto mode lets you see the signal with very little adjustment, while the normal mode selects the interesting part of the waveform. If you want to acquire a specified number of waveforms with NxSingle, make sure to select the normal trigger mode. Thus you get only the required number of interesting acquisitions.

See also: [chapter 4, "Triggers"](#), on page 133

3.1.3 Horizontal System

3.1.3.1 Parameters of the Horizontal System

The control parameters of the horizontal system are tightly connected. Thus, changing one parameter affects the other parameters as well.

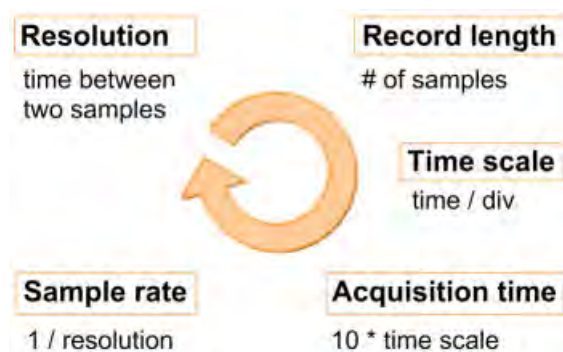

The mathematical dependencies can be summarized as follows:

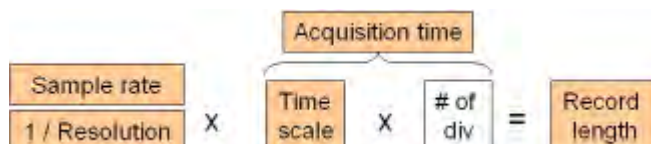

The number of divisions is 10, this is the only constant parameter.

When you set up horizontal parameters, you can choose whether the record length or the resolution should remain constant.

- With constant resolution, increasing the time scale also increases the record length, and vice versa. You can limit the record length to a maximum value.
- With constant record length, increasing the time scale coarsens the resolution, that is, the time between two waveform samples gets longer.

For both settings, the "Auto adjustment" ensures a sufficient resolution to prevent undersampling.

3.1.3.2 Horizontal Position

As described before in [chapter 3.1.2.3, "Acquisition Control"](#), on page 95, the trigger is the determining point of the waveform record.

In many scenarios, you might want to analyze the waveform some time before or after the trigger. To adjust the horizontal acquisition window to the waveform section of interest, you can use the following parameters:

- The **horizontal position** defines the time distance from the trigger point (the zero point of the diagram) to the reference point. Changing the horizontal position, you can move the trigger point, even outside the screen.
- The **reference point** is the rescaling center of the time scale on the screen. If you modify the time scale, the reference point remains fixed on the screen, and the scale is stretched or compressed to both sides of the reference point.

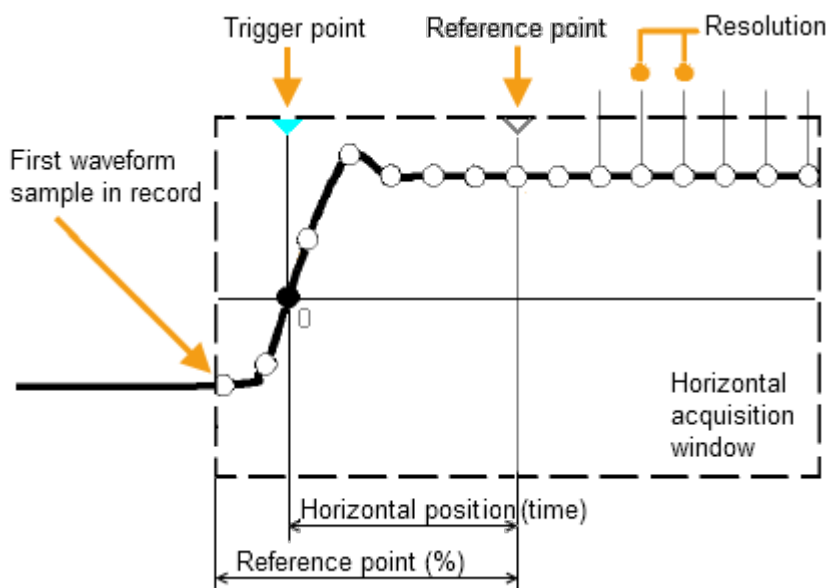

3.1.4 Probes

A probe connects the signal source (DUT) to the oscilloscope, and delivers the signal to be measured. It is the essential first link in the measurement chain.

An ideal probe fulfills the following requirements:

- Safe and reliable contacts
- Infinite bandwidth
- The probe should not load the signal source and thus impact the circuit operation.
- The connection should not introduce or suppress signal components (hum, noise, filter) and thus degrade or distort the transferred signal.

In reality, the probe can never be an ideal one, it always affects the signal transmission and the signal source, and thus the measured signal. It depends on the frequency to be measured and on the signal source to determine the acceptable loading, and to determine which kind of probe delivers good results.

The solution depends on the quantity to be measured with respect to:

- Signal type: voltage, current, power, pressure, optical, etc.

- **Signal amplitude:** The oscilloscope itself can only display voltages in a limited range. Most probes can adjust the dynamic range to amplitudes from a few mV to 10 V. Smaller or much larger signals require specialized equipment.
- **Signal frequency:** High frequencies require advanced equipment in order to get correct results.
- **Source characteristic:** The source impedance is the decisive factor when choosing the suitable connection.

3.1.4.1 Voltage Probes

The following table provides an overview on common voltage probes and their usage.

Table 3-1: Voltage probes overview

Probe type	Attenuation	Typical bandwidth range	Oscilloscope input	Usage
Passive, high impedance	1:1	10 MHz	1 MΩ	Low speed, low level signals
Passive, high impedance	10:1	500 MHz	1 MΩ	General purpose
Passive, low impedance	10:1	up to 10 GHz	50 Ω	High frequency
Active, single-ended	10:1	up to 10 GHz	50 Ω	High speed
Active, differential	10:1		50 Ω	Floating

For a list of recommended probes refer to the R&S RTO product brochure.

Besides the possible input voltage range, two factors are very important when selecting a voltage probe: Bandwidth and impedance over frequency.

- **Bandwidth:**

The combination of probe and oscilloscope builds up a system. The resulting system bandwidth is approximately determined with:

$$\frac{1}{BW_{system}} = \sqrt{\left(\frac{1}{BW_{probe}}\right)^2 + \left(\frac{1}{BW_{scope}}\right)^2}$$

To measure the signal with low measurement error, the system bandwidth should be higher than the highest frequency component of the signal. The probe bandwidth must be even higher than the system bandwidth.

- **Impedance:**

A minimum impedance is required to keep the circuit loading low. Over frequency, the impedance decreases, in particular with passive probes. The probe impedance should be approximately 10 times the impedance of the circuit test point at the highest signal frequency.

Passive voltage probes

Passive probes have the following qualities:

- No active components inside

- BNC connector for universal use
- Compensation needs to be executed when the probe is connected to a scope input: LF compensation matches the probe (mainly cable) capacitance to the oscilloscope input capacitance.
- With high impedance probes, the impedance varies significantly over frequency.
- With low impedance probes, the impedance variation over frequency is low, but the load on the source is high.

If you use passive probes, remember some recommendations:

- Use a probe recommended for your oscilloscope model.
- Use a ground lead as short as possible to minimize the effect of ground lead inductance. The resonance frequency can be much lower than the system bandwidth and thus can affect the measurement results, in particular, if you measure steep edge rise times.
- Select a probe that has a bandwidth of 5 to 10 times the highest frequency being measured. This will preserve the harmonics and thus the waveform integrity.

Active voltage probes - general

Active probes require operating power from the instrument and have a proprietary interface to the instrument. Their main qualities are:

- Low loading on signal source
- The probe is automatically recognized by the instrument, no adjustment is required.
- Adjustable DC offset at probe tip allows for high resolution on small AC signals which are superimposed on DC levels.
- Connections should be as short as possible to keep the usable bandwidth high.
- The operating voltage range has to be observed.
- The probe impedance depends on the signal frequency.

RT-ZS single-ended active probes and RT-ZD differential active probes provide special features for easier use and precise measurements. These special features are not available on RT-ZSxxE probes.

- The micro button on the probe head remotely controls important functions on the instrument, like running and stopping the acquisition, autose, AutoZero and setting the offset to mean value.
- The R&S ProbeMeter measures DC voltages between the probe tip and the ground connection with very high precision. The result is displayed on the instrument's screen. So you can check DC voltages with different levels without having to adjust the measurement range of the oscilloscope. The R&S ProbeMeter also measures the zero error of the probe to optimize measurement results at small signal levels.

When you connect an R&S RT-ZSxx active probe to a channel input of the R&S RTO, the oscilloscope recognizes the probe, reads the identification and calibration data from the probe box and shows the result in the "Setup" and "Probe Attributes" tabs. This data together with the deskew time for a given channel is stored and processed

by the R&S RTO. If you connect the probe the next time to the same channel, the information is fetched and used.

Differential active probes

Differential active probes are designed to measure signals that are referenced against each other, and voltages that are not references to ground, for example twisted pair signal lines. The R&S RT-ZD probes are differential probes with high input impedance, they can be used to measure voltages between any two test points.

Compared with two-channel measurement setup with single-ended probes, the measurement with differential probes is symmetric due to the same amplification and cable length on both paths. It is also immune to interference and noise and occupies only one input channel.

A differential probe has three sockets: the positive signal socket (+), the negative signal socket (-), and the ground socket.

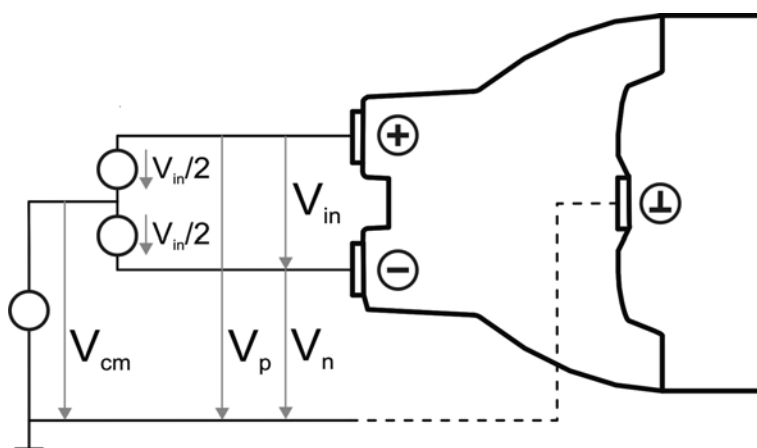

Multiple input voltages can be defined for a differential probe:

- Differential mode input voltage (V_{in} , V_{dm})
Voltage between the positive and negative signal sockets
- Positive single-ended input voltage (V_p)
Voltage between the positive signal socket and the ground socket
- Negative single-ended input voltage (V_n)
Voltage between the negative signal socket and the ground socket
- Common mode input voltage (V_{cm})
Mean voltage of positive and negative signal sockets referred to the ground socket, respectively

Two of these voltages are independent values, the other two can be calculated:

$$V_{in} = V_p - V_n$$

$$V_{cm} = \frac{V_p + V_n}{2}$$

R&S RT-ZD probes detect only differential input voltages and provide it to the oscilloscope. Common mode signals are suppressed by the probe. This characteristic is described by the Common Mode Rejection Ratio (CMRR):

$$CMRR = \frac{\text{DifferentialGain}}{\text{CommonModeGain}}$$

In addition, the R&S ProbeMeter of R&S RT-ZD differential probes can measure differential and common mode DC voltages. The measurement result is displayed on the oscilloscope's screen. The common mode measurement of the R&S ProbeMeter allows to check the input voltage relative to ground and is a convenient way to detect breaches of the operating voltage window, and the reason of unwanted clippings.

3.2 Setting Up the Waveform

This chapter contains the fundamental procedures for setting up the acquisition and adjusting the channel waveforms.

3.2.1 Setting Up the Signal Input with Autoset

Autoset is the solution for the major part of routine test-setup. It is also a good start if you need to use more complex trigger settings. Autoset finds appropriate horizontal and vertical scales, vertical offset, and trigger conditions to present a stable waveform.

1. Connect the probe to the input connector CH N.
The instrument recognizes the probe and turns the channel on.
2. Press the AUTOSET button on the left of the display.

3.2.2 Adjusting the Signal Input Manually

1. Connect the probe to the input connector CH N.
The instrument recognizes the probe and turns the channel on.
2. On the "Horizontal" menu, tap "Time Base".
3. Set the "Time scale".
4. If you want to analyze the signal some time before or after the trigger, use the "Trigger offset", "Horizontal position" and "Reference point" to adjust the visible section of the waveform.
5. Tap the "Resolution" tab.
6. Select to set either the resolution or the record length and enter the required value.

7. Press the channel button corresponding to the input channel. It is illuminated with the color of the channel waveform.
8. In the "Channels" tab, select the "Coupling".
9. Adjust the vertical "Scale", and the vertical "Position".
10. Tap "Acquisition" to proceed with the acquisition setup.

3.2.3 Setting the Acquisition

Prerequisites:

- Probes are connected.
- Vertical and horizontal settings are adjusted.

The settings are described in [chapter 3.3.1.3, "Acquisition"](#), on page 110.

1. On the "Horizontal" menu, tap "Acquisition".
2. Select the "Enhancement".
If "Interpolated time" is set, select also the "Interpolation mode".
Enhancement affects all waveforms of all channels. The instrument uses enhancement settings if the "ADC sample rate" is less than the "Sample rate"; otherwise these settings are ignored.
3. To configure the waveform-specific acquisition settings, select the "Channel" tab and activate the waveform.
You can set up and display up to three waveforms per channel.
4. Select the "Decimation" - for example, Peak detect or High res.
5. Select the "Wfm Arithmetic" - for example, Average or Envelope.
The instrument precludes incompatible combinations, like "Peak detect" with "Average".
6. If "Average" is selected for a waveform, enter the "Average count", that is the number of waveforms used for average calculation.
7. Set the reset condition for the average and envelope calculation:
 - a) If "Time" is selected, enter the "Reset time".
 - b) If "Waveforms" is selected, enter the "Reset count".

3.2.4 Starting and Stopping Acquisition

You can control the acquisition in two ways:

- Running continuous acquisition until you stop it.
- Running one acquisition or a given number of acquisitions.

If "Envelope" or "Average" is selected in the "Acquisition" tab, one acquisition means a cycle containing as many acquired waveforms as required to satisfy the reset conditions.

Prerequisites:

- Probes are connected.
- Vertical and horizontal settings are adjusted.
- Triggering is set.
- Channels to be acquired are turned on.

To start and stop continuous acquisition

1. Check if the trigger mode is set to "Normal". The trigger mode is shown in the trigger label in the upper right edge of the screen.
If not, press the trigger MODE key on the front panel to toggle the setting.
2. Press the RUN CONT key to start acquisition.
The acquisition starts if a trigger occurs.
3. To stop, press the RUN CONT key again.
The acquisition stops immediately.

To acquire a limited number of acquisitions

1. Press the TRIGGER key and tap the "Control" tab.
2. In the "Control" area, select the "Normal" trigger mode.
3. Enter the number of acquisitions in the "Average count" field.
4. Press the RUN N× SINGLE key on the front panel.
You can stop the running acquisition before it is finished by pressing the key again.

3.2.5 Using the Roll Mode

The roll mode can be used if the acquisition process is slow - that is if the time scale is large. In roll mode, the instrument shows the waveform immediately and saves waiting for the waveform display. The roll mode can be activated by the instrument if several conditions are fulfilled.

To set the roll mode manually

1. Make sure that all requirements for the roll mode are fulfilled: see ["Mode"](#) on page 107.
2. Press the HORIZONTAL key.
3. In the "Roll mode" section of the "Time Base" tab, set "Mode" to "Auto".
4. In the "Min roll mode gain" field, enter the acquisition time at which the instrument starts the roll mode.

3.2.6 Using Ultra Segmentation

Ultra Segmentation reduces the dead time between two waveform acquisition cycles.

The settings are described in [chapter 3.3.1.4, "Ultra Segmentation"](#), on page 113.

1. On the "Horizontal" menu, tap "Ultra Segmentation".
2. Tap "Enable" to activate the Ultra Segmentation mode.
3. If you want to sample the maximum number of acquisitions in a series, select "Acquire maximum".
If you want to capture a defined number of acquisitions, disable "Acquire maximum" and enter the "Required" number of acquisitions.
4. Set the "Replay time", the display time of each acquisition.

3.2.7 Using Digital Filters

Before using digital filters, you determine if you want to filter input channels only or if the trigger signal will be filtered too. The filter settings depend on this decision.

For details on filter settings and dependencies, see [chapter 3.3.4, "Digital Filter Setup"](#), on page 128.

To filter the input channels only

1. On the "Vertical" menu, tap "Digital Filter Setup".
2. Set the "Trigger coupling" to "Off".
3. Enter the "Cut-off" frequency for each filter.
4. Enable "Use filter" for each channel to be filtered.

To filter the trigger signal

1. On the "Vertical" menu, tap "Digital Filter Setup".
2. Set the "Trigger coupling" to "RF Reject".
3. Set the frequency limit for the filter: "RF reject BW".
4. To filter the input channels too, enable "Use filter" for each channel to be filtered. The trigger filter settings are applied also to these input channels.

3.3 Reference for Acquisition and Setup

- [Horizontal Settings](#)..... 105
- [Vertical Settings](#)..... 116
- [Probes](#)..... 119
- [Digital Filter Setup](#)..... 128
- [Horizontal Accuracy](#)..... 130

3.3.1 Horizontal Settings

The "Horizontal" menu provides the time base and acquisition configuration for channel and FFT waveforms:

- [Time Base](#)..... 105
- [Resolution](#)..... 108
- [Acquisition](#)..... 110
- [Ultra Segmentation](#)..... 113

3.3.1.1 Time Base

The "Time Base" tab in the "Horizontal" dialog box provides the basic settings for the time axis and the roll mode settings.

For background information, see [chapter 3.1.3, "Horizontal System"](#), on page 96.

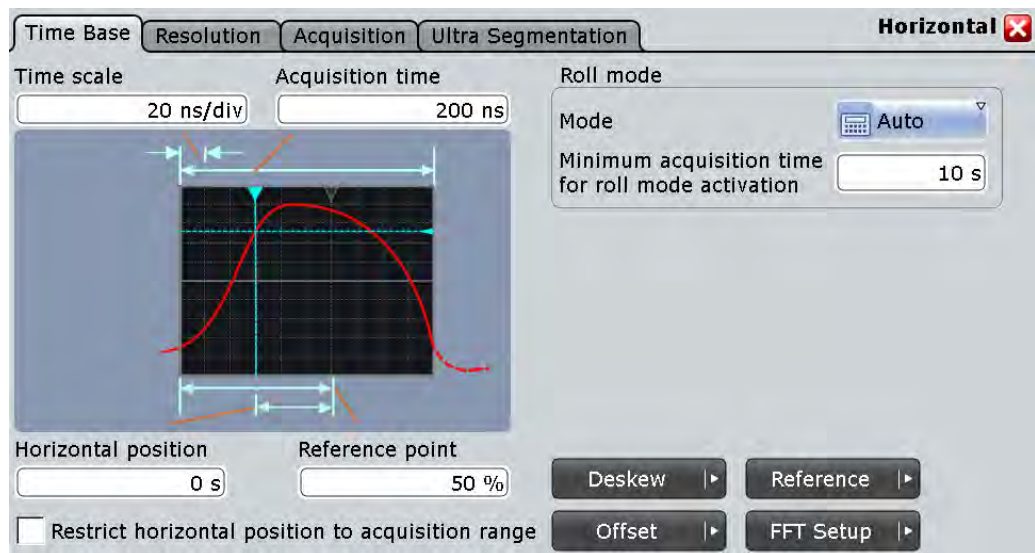



Waveform display

Certain conditions cause a freeze of the waveform display on the screen:

- The acquisition has been stopped.
- One of the following actions has been performed:
 - Activating an additional channel
 - Interleaved mode is active (20 GHz realtime sample rate, available only with R&S RTO1044)
- If you change the vertical or horizontal scale or position, the reference point, or the offset under these conditions, only the grid is updated, and the waveforms remain unchanged. The instrument updates the waveform display when you start acquisition.

Time scale

Sets the horizontal scale for all channel and math waveforms in seconds per division. Increase the scale to see a longer time interval of the waveform. Decrease the scale to see it in more detail. The scale has a point that remains fixed on the screen when the scale value is changing - the reference point.

See also: "[Waveform display](#)" on page 106

Remote command:

[TIMEbase:SCALE](#) on page 677

Acquisition time

Shows the time of one acquisition, that is the time across the 10 divisions of the diagram:

Acquisition time = Time scale * 10 divisions

Changing the acquisition time changes the time scale too.

Remote command:

[TIMEbase:RANGe](#) on page 677

Horizontal position

Defines the time distance between the reference point and the trigger point (the zero point of the diagram). If you want to see a section of the waveform some time before or after the trigger, enter this time as horizontal position. The requested waveform section is shown around the reference point. Use positive values to see waveform sections after the trigger - the waveform and the diagram origin move to the left.

See also:

- "[Reference point](#)" on page 107
- "[Waveform display](#)" on page 106

Remote command:

[TIMEbase:HORizontal:POSition](#) on page 677

Reference point

Sets the position of the reference point in % of the screen. The reference point marks the rescaling center of the time scale. It is indicated by a grey triangle outline at the top of the diagram. If you modify the time scale, the reference point remains fixed on the screen, and the scale is stretched or compressed to both sides of the reference point.

See also: "[Waveform display](#)" on page 106

Remote command:

[TIMEbase:REFerence](#) on page 678

Restrict horizontal position to acquisition range

If enabled, the horizontal position cannot be set outside the visible waveform diagram.

Roll mode

Configures the roll mode for slow time bases:

Mode ← Roll mode

Activates the automatic roll mode. If set to "Auto", the instrument activates the roll mode under specific conditions. In roll mode, the instrument shows the waveforms immediately, without waiting for the complete acquisition of the waveform record. If the time base is slow - at long time scale values - the roll mode saves waiting for the waveform display. The instrument displays newly acquired waveform points at the right edge of the display and moves the waveform to the left.

The roll mode is activated automatically if the following conditions are fulfilled:

- Acquisition time exceeds the "Minimum acquisition time for roll mode activation"
- Record length is ≤ 1 MSa
- Waveform arithmetic is disabled ("Off")
- All channel waveforms are set to the same decimation mode, and to one of these values: "Sample", "Peak detect", or "High res"
- All measurements are disabled
- All mask tests are disabled
- Ultra Segmentation is disabled
- FFT is disabled
- All serial buses are disabled

The roll mode has following restrictions:

- Roll mode disables persistence
- History is not available
- If more than one waveform for an active channel is enabled, the instrument disables the roll mode.

Remote command:

[TIMEbase:ROLL:ENABLE](#) on page 678

Minimum acquisition time for roll mode activation ← Roll mode

The instrument can activate the roll mode automatically if the [Acquisition time](#) exceeds the value given here.

Remote command:

[TIMEbase:ROLL:MTIME](#) on page 678

3.3.1.2 Resolution

The settings in the "Resolution" tab mainly define the precision of the waveform record.

The resolution settings interact, changing one parameter affects one or more of the other parameters as well. For background information, see [chapter 3.1.3, "Horizontal System"](#), on page 96.

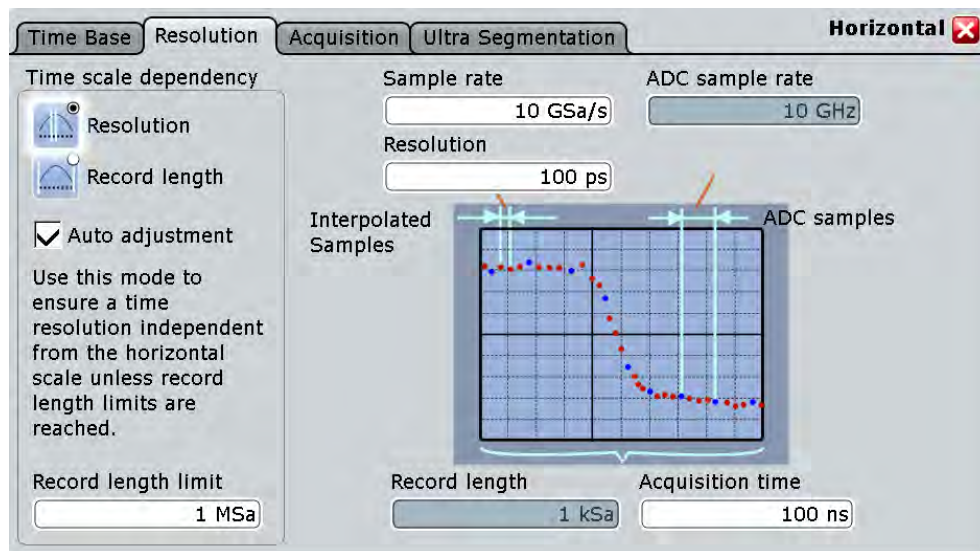

Sample rate

Sets the number of recorded waveform points per second. The sample rate is the reciprocal value of the resolution and thus also depends on the acquisition time and the record length. It considers the samples of the ADC, the additional waveform points resulting from resolution enhancement (interpolation and equivalent-time sampling), and the reduction of waveform points by decimation.

See also:

- [chapter 3.1.2, "Sampling and Acquisition"](#), on page 92
- [chapter 3.1.3, "Horizontal System"](#), on page 96

Remote command:

[ACQUIRE:SRATE](#) on page 680

ADC sample rate

Shows the number of points that are sampled by the ADC in one second. The ADC sample rate is a constant of the instrument.

Remote command:

[ACQUIRE:POINTS:ARATE?](#) on page 680

Resolution

Sets the time between two waveform samples. A fine resolution with low values produces a more precise waveform record.

Remote command:

[ACQUIRE:RESOLUTION](#) on page 680

Record length

Indicates the number of waveform samples that build the waveform across the acquisition time.

Remote command:

[ACQUIRE:POINTS\[:VALUE\]](#) on page 680

Acquisition time

Shows the time of one acquisition, that is the time across the 10 divisions of the diagram:

Acquisition time = Time scale * 10 divisions

Changing the acquisition time changes the time scale too.

Remote command:

[TIMEBASE:RANGE](#) on page 677

**Resolution / Record length (Time scale dependency)**

You can choose to keep constant either the resolution or the record length when you adjust the time scale or acquisition time.



- With constant resolution, increasing the time scale also increases the record length, and vice versa. You can limit the record length to a maximum value.
- With constant record length, increasing the time scale coarsens the resolution, that is, the time between two waveform samples gets longer.

Remote command:

[ACQUIRE:POINTS:AUTO](#) on page 679

Auto adjustment (Time scale dependency)

Prevents undersampling and ensures a sufficient resolution to acquire the correct waveform if the time scale is changed. The setting takes effect if the changed parameter - resolution or record length - reaches a limit. The instrument automatically keeps this parameter constant at its limit, and changes the other parameter regardless of the "Resolution / Record length" setting.

See also: [Resolution / Record length \(Time scale dependency\)](#)

Record length limit (Time scale dependency)

Sets a limit for the record length to prevent very large records. This value is only available if "Auto adjustment" is on and a constant resolution is selected. If you increase the time scale, the resolution remains constant and the record length increases until the limit is reached. Further increase of the time scale changes the resolution and keeps the record length limit.

See also:

- [Resolution / Record length \(Time scale dependency\)](#)
- [Auto adjustment \(Time scale dependency\)](#)

Remote command:

[ACQUIRE:POINTS:MAXIMUM](#) on page 679

3.3.1.3 Acquisition

Acquisition settings control how the waveform is built from the acquired samples. You can display up to three waveforms from one input signal and apply different decimation and arithmetic to each waveform.

For background information, see [chapter 3.1.2, "Sampling and Acquisition"](#), on page 92.

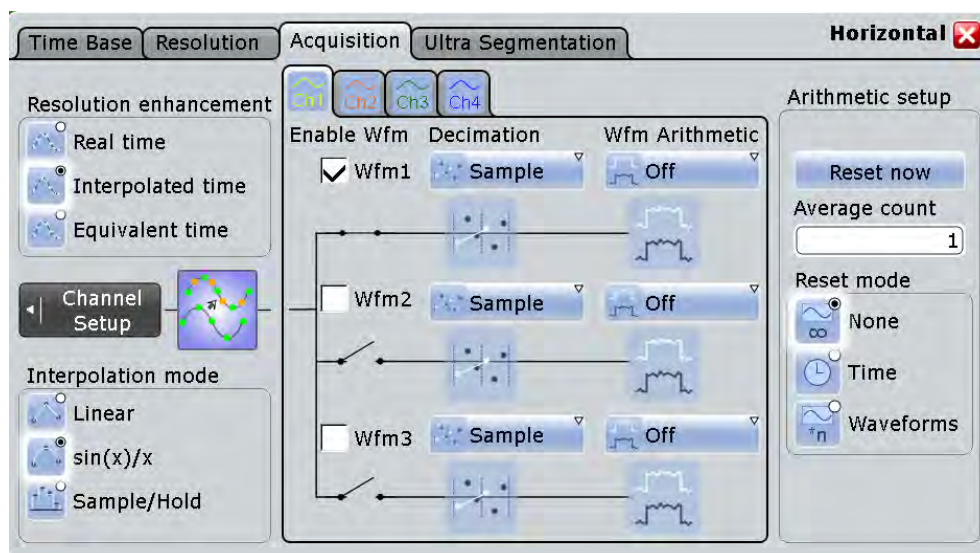

Channel-dependent settings

The "Decimation" and "Wfm arithmetic" are specific for each waveform. Make sure to select the channel tab first, then set up the waveforms.



Resolution enhancement

If the ADC sample rate is too slow to capture sufficient samples to achieve the required resolution, the sample rate can be increased by adding calculated points to the waveform record. The enhancement method is the same for all channels and waveform. As long as the waveform sample rate is not higher than the ADC sample rate, the instrument works automatically in real time mode, enhancement settings are ignored. Otherwise - for resolutions faster than 100ps - the instrument changes to interpolated time mode. If enhancement is done, the instrument ignores the decimation settings.

The methods are:

- | | |
|---------------------|--|
| "Real time" | The sampled points of the input signal are used directly to build the waveform. Actually, the real time mode is not an enhancement mode. The maximum "Sample rate" is the "ADC sample rate". In this mode, decimation can be set to reduce the amount of data. The real time mode is used to acquire non-repetitive and transient signals. |
| "Interpolated time" | If the "Sample rate" is higher than the "ADC sample rate", interpolation adds points between the ADC samples of the waveform by various mathematic methods, see Interpolation mode . This is the default enhancement method. |

"Equivalent time"
This method requires repetitive, stable signals and is not suitable for random and non-repetitive signals. It is used to capture fast signals whose frequency components are higher than the "ADC sample rate". Equivalent-time sampling constructs a picture of a repetitive signal by capturing a little bit of information from each repetition. Each sample is taken with some time difference after the trigger, and the time difference varies with each repetition of the signal. After a number of acquisitions, the oscilloscope builds the waveform from the sampled points.

The R&S RTO uses the sequential equivalent-time sampling method. When a trigger occurs, a sample is taken after a very short delay time. At the next trigger, this delay time is incremented by a precisely defined Δt , and the next sample is taken. This process is repeated until the waveform is complete. Sequential equivalent-time sampling provides very good time resolution and accuracy.

Equivalent-time sampling is not available, if digital channels are active (requires option RTO-B1, MSO).

Remote command:

[ACquire:MODE](#) on page 681



Interpolation mode

Selects the interpolation method if "Interpolated time" is set for enhancement.



"Linear"

Two adjacent ADC sample points are connected by a straight line, the interpolated points are located on the line. You see a polygonal waveform similar to the real signal, and also the ADC sample points as vertexes.



"sin (x)/x"

Two adjacent ADC sample points are connected by a $\sin(x)/x$ curve, and also the adjoining sample points are considered by this curve. The interpolated points are located on the resulting curve. This interpolation method is very precise and shows the best signal curve.

"Sample/Hold"

The ADC sample points are displayed like a histogram. For each sample interval, the voltage is taken from the sample point and considered as constant, and the intervals are connected with vertical lines. Thus, you see the discrete values of the ADC - the actually measured samples.

Remote command:

[ACquire:INTerpolate](#) on page 681

Enable Wfm

Activates or deactivates the individual waveforms of the selected channel.

For each channel, up to three waveforms can be shown and analyzed. The decimation mode and the trace arithmetic are specific for each waveform. So you can analyze several aspects of the signal: For example, waveform1 shows the peaks, and waveform2 shows the average of the signal.

Remote command:

[CHANnel<m> \[:WAVeform<n>\] \[:STATe\]](#) on page 682



Decimation

Decimation reduces the data stream of the ADC to a stream of waveform points with lower sample rate and a less precise time resolution. The R&S RTO uses decimation, if the waveform "Sample rate" is less than the "ADC sample rate". In this case, enhancement settings are ignored. The decimation mode is waveform-specific, you can select another mode for each waveform.



There are different methods to define the recorded waveform point out of a number of n sample points:

- "Sample" One of n samples in a sample interval of the ADC is recorded as waveform point, the other samples are discarded. The time between the two adjacent waveform points is exactly the resolution. Very short glitches might remain undiscovered by this method.
- "Peak detect" The minimum and the maximum of n samples in a sample interval are recorded as waveform points, the other samples are discarded.
- "High res" The average of n sample points is recorded as one waveform sample. Averaging reduces the noise, the result is a more precise waveform with higher vertical resolution.
- "RMS" The waveform point is the root mean square of n sample values. Thus, the RMS value reflects the instantaneous power.

Remote command:

`CHANnel<m>[:WAVeform<n>]:TYPE` on page 682



Wfm Arithmetic

Waveform arithmetic builds the resulting waveform from several consecutive acquisitions of the signal. This setting is waveform-specific. The arithmetic works with enhanced and decimated waveforms.



The methods are:



- "Off" The data of only one acquisition is recorded according to the decimation settings. In effect, no waveform arithmetic are processed.
- "Envelope" Detects the minimum and maximum values in an sample interval over a number of acquisitions. Each acquisition is done in the "Peak detect" decimation mode, and the most extreme values for all acquisitions build the envelope. The resulting diagram shows two envelope waveforms: the minimums (floor) and maximums (roof). The envelope is built until the restart criterion is reached, see "[Reset mode](#)" on page 113.
Note: If you change the arithmetic from "Envelope" to "Off", make sure to set also the "Decimation" to the required value.
- "Average" The average is calculated from the data of the current acquisition and a number of acquisitions before. The method reduces random noise and other heterodyne signals. It requires a stable, triggered and periodic signal for correct function. The number of acquisitions for average calculation is defined with "Average count", and the "Reset mode" defines the restart condition.

Remote command:

`CHANnel<m>[:WAVeform<n>]:ARITHmetics` on page 683

Reset Now

Forces the immediate restart of the envelope and average calculation for all waveforms, ignoring the reset settings.

Remote command:

[ACQUIRE:ARESet:IMMediate](#) on page 683

Acquisition/average count

Access:

- TRIGGER > "Control" tab > "Average count (N-single count)"
- ACQUISITION > "Average count"
- HORIZONTAL > "Ultra Segmentation" tab > disable "Acquire maximum" > "Required"
- MATH > "Setup" tab > "Average count"

The acquisition and average count has several effects:

- It sets the number of waveforms acquired with RUN N× SINGLE.
- It defines the number of waveforms used to calculate the average waveform. Thus, the instrument acquires sufficient waveforms to calculate the correct average if "Average" is enabled for waveform arithmetic. The higher the value is, the better the noise is reduced.
- It sets the number of acquisitions to be acquired in an Ultra Segmentation acquisition series. Thus, you can acquire exactly one Ultra Segmentation acquisition series with RUN N× SINGLE.
If Ultra Segmentation is enabled and configured to acquire the maximum number of acquisitions, the acquisition count is set to that maximum number and cannot be changed. See also: ["Number of acquisitions"](#) on page 115.
- It is the "Finished" criteria for the state of a mask test.

Remote command:

[ACQUIRE:COUNT](#) on page 683

**Reset mode**

Defines when the envelope and average evaluation restarts.



"None" No restart, the number of acquisitions considered by the waveform arithmetics is not limited.



"Time" Restarts the envelope and average calculation after the time defined in "Reset time".



"Waveforms" Restarts the envelope and average calculation after a number of acquired waveforms defined in "Reset count".

Remote command:

[ACQUIRE:ARESet:MODE](#) on page 684

[ACQUIRE:ARESet:TIME](#) on page 684

[ACQUIRE:ARESet:WFMCOUNT](#) on page 684

3.3.1.4 Ultra Segmentation

In normal acquisition mode, only a short time is used for sampling; processing and display takes most of the time. The processing and display time is blind time causing a

gap in the recorded signal. The normal acquisition mode may miss very short time and infrequent events occurring during the dead time.

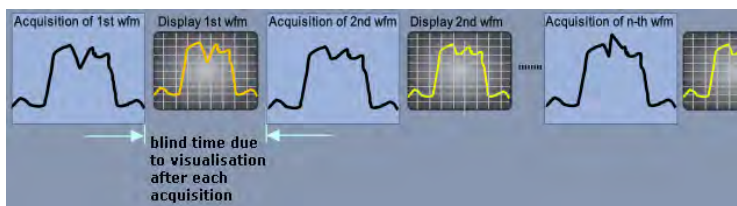

Fig. 3-5: Normal acquisition with blind time

With Ultra Segmentation, a number of triggered acquisitions is captured very fast, with hardly any dead time between the acquisitions. The data is processed and the waveforms are displayed when the acquisition of the series has been completed.

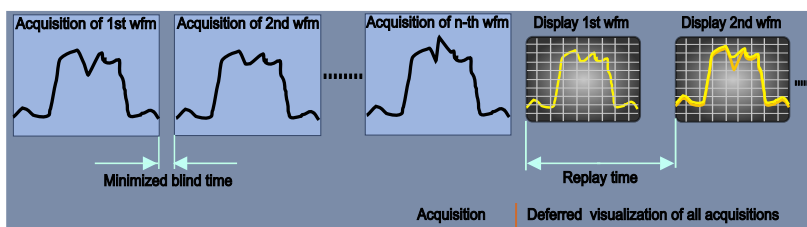

Fig. 3-6: Ultra Segmentation with deferred processing and display

Ultra Segmentation and History

The acquisition series is written in the sample memory, thus the memory size limits the number of acquisitions in a series. This memory is the memory that is accessed by the history, thus the history function is used to read out the contents of the sample memory.

To use the history functionality, enable "Show history" in the "Ultra Segmentation" tab. The history viewer settings are displayed directly in the "Ultra Segmentation" tab.

See also: [chapter 5.4, "History"](#), on page 207.

Restrictions

Ultra Segmentation and equivalent time sampling are mutually exclusive. The instrument considers this fact and disables Ultra Segmentation when equivalent time sampling is selected, and vice versa.

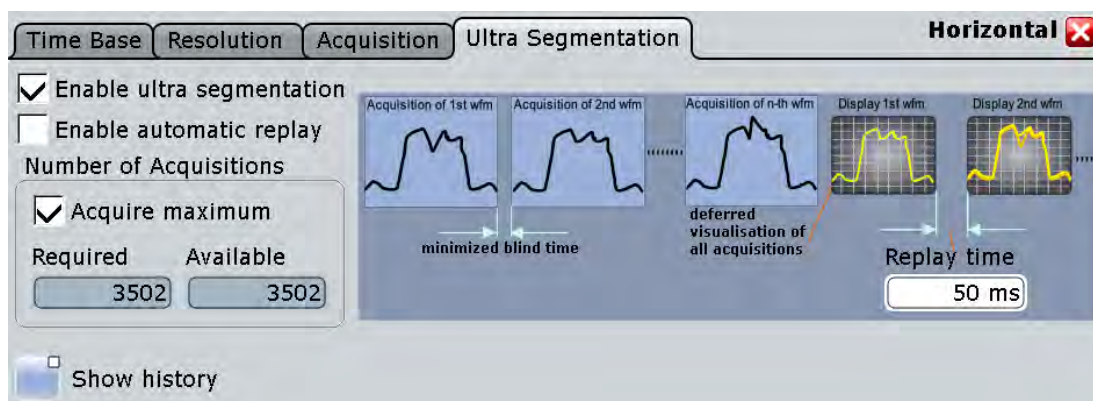

Enable ultra segmentation

Switches the Ultra Segmentation mode on and off.

If "Equivalent time" sampling is selected in the "Acquisition" tab, enabling Ultra Segmentation switches the resolution enhancement to "Interpolated time".

Remote command:

[ACQUIRE:SEGmented:STATe](#) on page 684

Enable automatic replay

If enabled, the instrument starts processing and displaying the data as soon as the acquisition series is captured completely. Depending on the number of acquisitions, it may take some time until the acquisition series is displayed. If the setting is disabled, the instrument only captures the data and stores it in the sample memory.

Remote command:

[ACQUIRE:SEGmented:AUToreplay](#) on page 685

Number of acquisitions

You can define the number of acquisitions to stored in an Ultra Segmentation acquisition series:

- Acquire the maximum possible number of acquisitions that can be stored in the sample memory.
To acquire the maximum number, enable "Acquire maximum". The maximum number of acquisitions is shown in the "Required" field.
- Acquire a given number of acquisitions.
Enter the number in the "Required" field.

The acquisition count ([Acquisition/average count](#)) is always set to the required number of acquisitions. Thus you can acquire exactly one Ultra Segmentation acquisition series with RUN N× SINGLE. The RUN key works in the same way as RUN N× SINGLE, it stops acquisition when the series is completed.

You can stop the running acquisition before the series is completed.

The number of actually acquired waveforms is shown in "Available" and can be displayed with "Show history".

Remote command:

[ACQUIRE:SEGmented:MAX](#) on page 685

Replay time

Defines the display speed of the Ultra Segmentation acquisition series. Display starts after the series has been captured completely. See also "Time per acquisition" on page 212.

Show history

Enables the history mode and displays the history viewing functions in the "Ultra Segmentation" tab. For details, see chapter 5.4.3.1, "Viewer", on page 211.

3.3.2 Vertical Settings

The "Vertical" menu contains all channel-dependent settings and information.

- Channels..... 116
- Power Calculation..... 118
- Coupled Channels..... 119

3.3.2.1 Channels

The "Channels" tab provides all basic vertical settings. The channels are listed in vertical tabs at the left side of the dialog box.

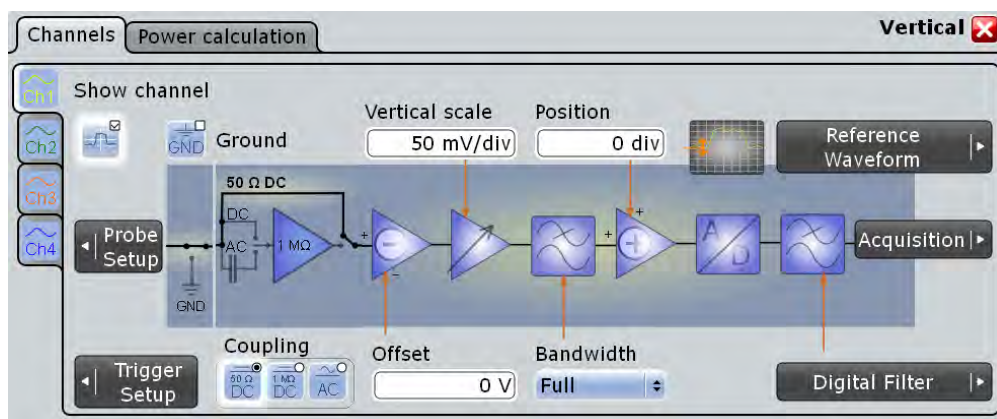

Make sure that the correct channel tab is selected. The vertical rotary knobs are illuminated in the color of the selected channel.



Waveform display

Certain conditions cause a freeze of the waveform display on the screen:

- The acquisition has been stopped.
- One of the following actions has been performed:
 - Activating an additional channel
 - Interleaved mode is active (20 GHz realtime sample rate, available only with R&S RTO1044)
- If you change the vertical or horizontal scale or position, the reference point, or the offset under these conditions, only the grid is updated, and the waveforms remain unchanged. The instrument updates the waveform display when you start acquisition.

Show channel

Switches the channel signal on or off. The signal icon appears on the signal bar. The waveform of the last acquisition is displayed in the diagram.

Remote command:

`CHANnel<m>:STATe` on page 685



Ground

Connects the input to the ground.



Coupling

Selects the connection of the channel signal determining what part of the signal is used for waveform analysis and triggering.



In addition to coupling, the signal can be filtered for high frequency rejection, see [chapter 3.3.4, "Digital Filter Setup"](#), on page 128.



- | | |
|-----------|---|
| "DC 50 Ω" | Connection with 50 Ω termination, passes both DC and AC components of the signal. |
| "DC 1 MΩ" | Connection with 1 MΩ termination, passes both DC and AC components of the signal. |
| "AC" | Connection through DC capacitor, removes DC and very low-frequency components. |

Remote command:

`CHANnel<m>:COUPling` on page 686

Offset

The offset voltage is subtracted to correct an offset-affected signal. The vertical center of the selected channel is shifted by the offset value and the signal is re-positioned within the diagram area. Negative offset values move the waveform up, positive values move it down.

The offset of a signal is determined and set by the autose procedure. The current value is shown in the waveform label.

By default, the horizontal grid axis remains in the center when the offset is changed. To shift the axis together with the waveform, disable [Keep Y-grid fixed](#) in "Display > Diagram Layout".

See also: "[Waveform display](#)" on page 117

Remote command:

[CHANnel<m>:OFFSet](#) on page 688

Vertical scale

Defines the vertical scale in Volts per division. Increasing the scale compresses the display of the signal.

See also: "[Waveform display](#)" on page 117

Remote command:

[CHANnel<m>:SCALE](#) on page 686

Bandwidth

Selects the bandwidth limit. The specified full bandwidth indicates the range of frequencies that the instrument can acquire and display accurately with less than 3dB attenuation. The probe has also a limited bandwidth and thus affects the resulting system bandwidth.

See also: [chapter 3.1.1.3, "Bandwidth"](#), on page 92

"Full" At full bandwidth, all frequencies in the specified range are acquired and displayed. Full bandwidth is used for most applications.

"800 MHz, 200MHz, 20MHz" Frequencies above the selected limit are removed to reduce noise at different levels. The value 800 MHz is provided for 50 Ω coupling.

Remote command:

[CHANnel<m>:BANDwidth](#) on page 688

Position

Moves the selected signal up or down in the diagram. The visual effect is the same as for [Offset](#) but the waveform is adjusted at a later time in the signal flow. While the offset sets a voltage, position is a graphical setting given in divisions.

By default, the horizontal grid axis remains in the center when the offset is changed. To shift the axis together with the waveform, disable [Keep Y-grid fixed](#) in "Display > Diagram Layout".

Remote command:

[CHANnel<m>:POSition](#) on page 687

3.3.2.2 Power Calculation



Make sure that the correct channel tab is selected.

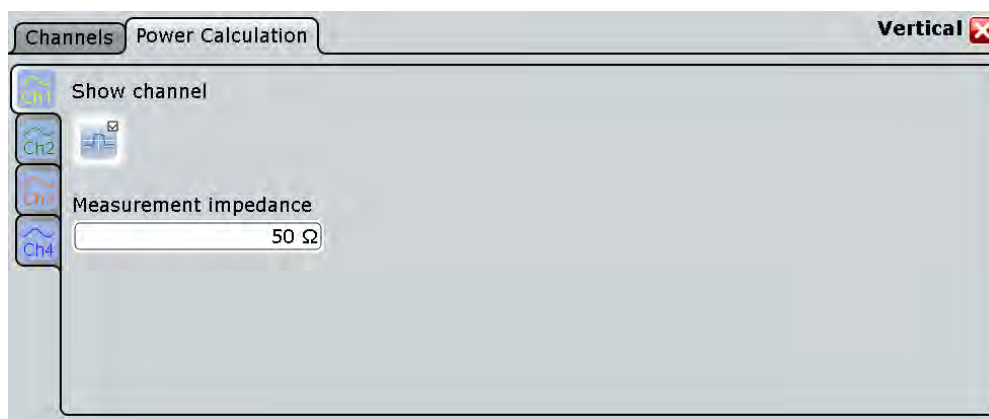

Show channel

Switches the channel signal on or off. The signal icon appears on the signal bar. The waveform of the last acquisition is displayed in the diagram.

Remote command:

[CHANnel<m>:STATe](#) on page 685

Measurement impedance

Sets the impedance of the channel for power calculations and measurements.

Remote command:

[CHANnel<m>:IMPedance](#) on page 688

3.3.2.3 Coupled Channels

Channel coupling sets the vertical settings of the coupled channels to the values of the active channel. If two or more channels should have the same vertical settings, you can set them at once by coupling the settings of these channels.

Channel coupling affects all vertical settings that are adjusted in the "Channels" tab: vertical scale, position, offset, bandwidth, coupling, and ground.

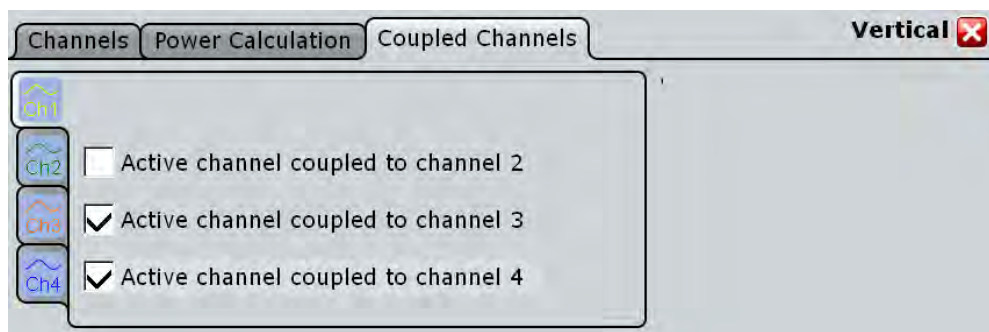

3.3.3 Probes

With R&S RTO digital oscilloscopes you can use various probe types, mostly these are passive and active voltage probes. The "Probes" dialog box provides all probe-relevant

information. The instrument can detect the R&S RT-ZP10 as well as R&S RT-ZS and R&S RT-ZD probes and read out the probe-specific parameters, for example, bandwidth and attenuation. Other probes cannot be detected, but their characteristics are known to the R&S RTO. These known probes are called "Predefined probes".

In the "Setup" tab, you find all settings that are relevant for the connected probe. Additional information is given in the "Probe Attributes" and "Calibration Results" tabs.

For background information, see [chapter 3.1.4, "Probes"](#), on page 97.

3.3.3.1 Setup for Passive and Unknown Probes

For passive probes, the probe attenuation is read out and shown in the "Setup" tab. Passive probes require compensation.

If you need to change the unit or attenuation, change the "Mode" to "Manual" and enter the correct values. Additionally, you can set an external attenuation.

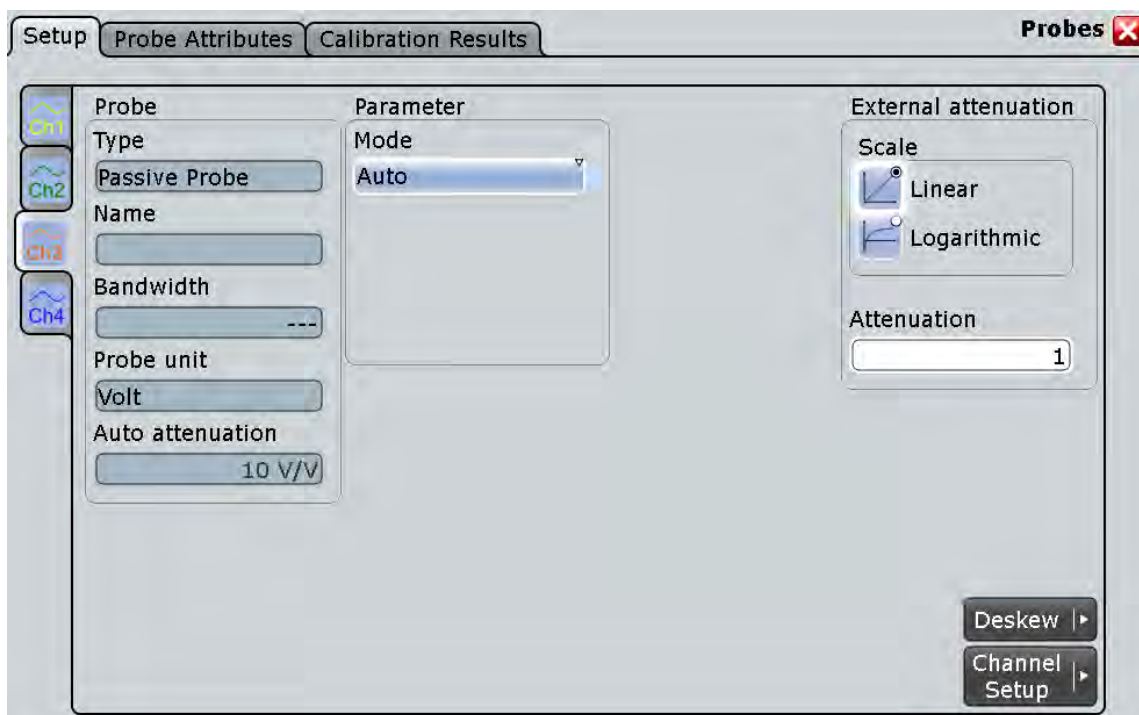

Fig. 3-7: Probe setup for passive probe R&S RT-ZP10

If the R&S RTO cannot detect the probe, and the probe is not a predefined one, you can set the probe parameters manually: unit and attenuation of the probe as well as external attenuation.

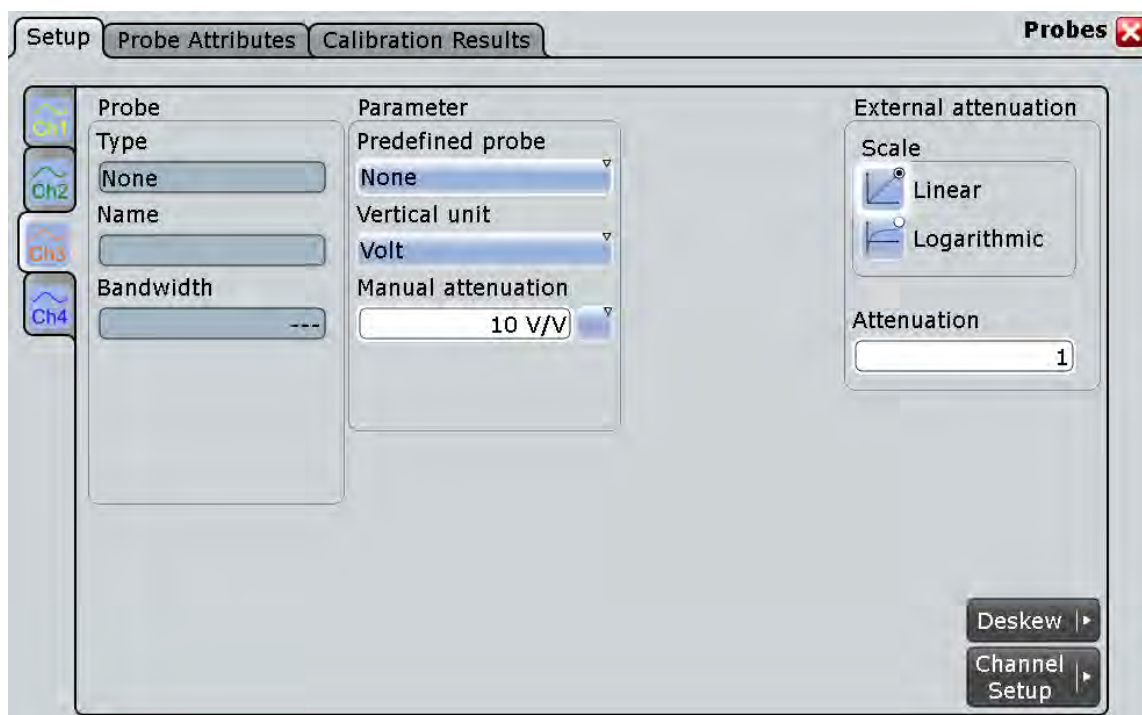

Fig. 3-8: Probe setup for an unknown probe

Type, Name, Bandwidth, Probe unit, Auto attenuation

Many probes are recognized by the instrument. The fields show the characteristics of a recognized probe for information. If the instrument cannot recognize the probe, the "Type" is "None".

Remote command:

`PROBe<m>:SETup:TYPE?` on page 696

`PROBe<m>:SETup:NAME?` on page 696

`PROBe<m>:SETup:BANDwidth?` on page 697

`PROBe<m>:SETup:ATTenuation[:AUTO]?` on page 691

Vertical unit, Manual attenuation, Manual gain

Set user-defined values for unit and attenuation or gain if the instrument cannot read the values.

Remote command:

`PROBe<m>:SETup:ATTenuation:UNIT` on page 692

`PROBe<m>:SETup:ATTenuation:MANual` on page 693

`PROBe<m>:SETup:GAIN:MANual` on page 693

External attenuation: Scale, Attenuation

Considers a voltage divider that is part of the DUT before the measuring point. The external attenuation is included in the measurement, and the instrument shows the results that would be measured before the divider. External attenuation can be used with active and passive probes.

"Scale" Select linear or logarithmic attenuation scale.

"Attenuation" Enter the attenuation of the voltage divider according to the selected scale. The conversion from linear to logarithmic values depends on the "Vertical unit" of the probe:

For power-based unit (W):

$$\text{attenuation (dB)} = 10 * \log_{10}(\text{attenuation factor})$$

For voltage-based unit (V and A):

$$\text{attenuation (dB)} = 20 * \log_{10}(\text{attenuation factor})$$

Remote command:

`CHANnel<m>:EATScale` on page 693

`CHANnel<m>:EATTenuation` on page 694

3.3.3.2 Setup for Active Probes R&S RT-ZS and R&S RT-ZD

Active single-ended probes R&S RT-ZS and active differential probes R&S RT-ZD (except for R&S RT-ZD01) have an integrated data memory that contains identification data and individual probe correction parameters. The R&S RTO can detect these active single-ended and differential probes and read out the data.

The Rohde & Schwarz active single-ended and differential probes have special features for easier use and precise measurements. The features and their settings appear on the tab if one of these probes is attached:

- Configuration of the micro button action
- DC measurement with R&S ProbeMeter

Additionally, you can set an external attenuation.

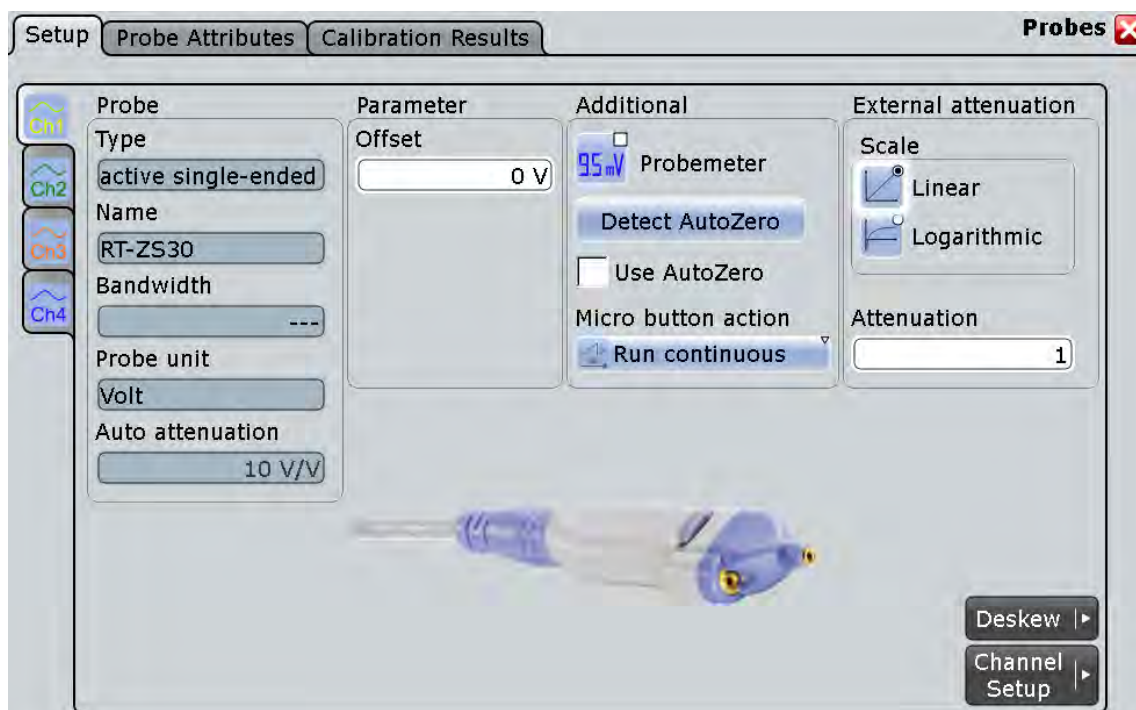

Fig. 3-9: Probe setup for active single-ended probes

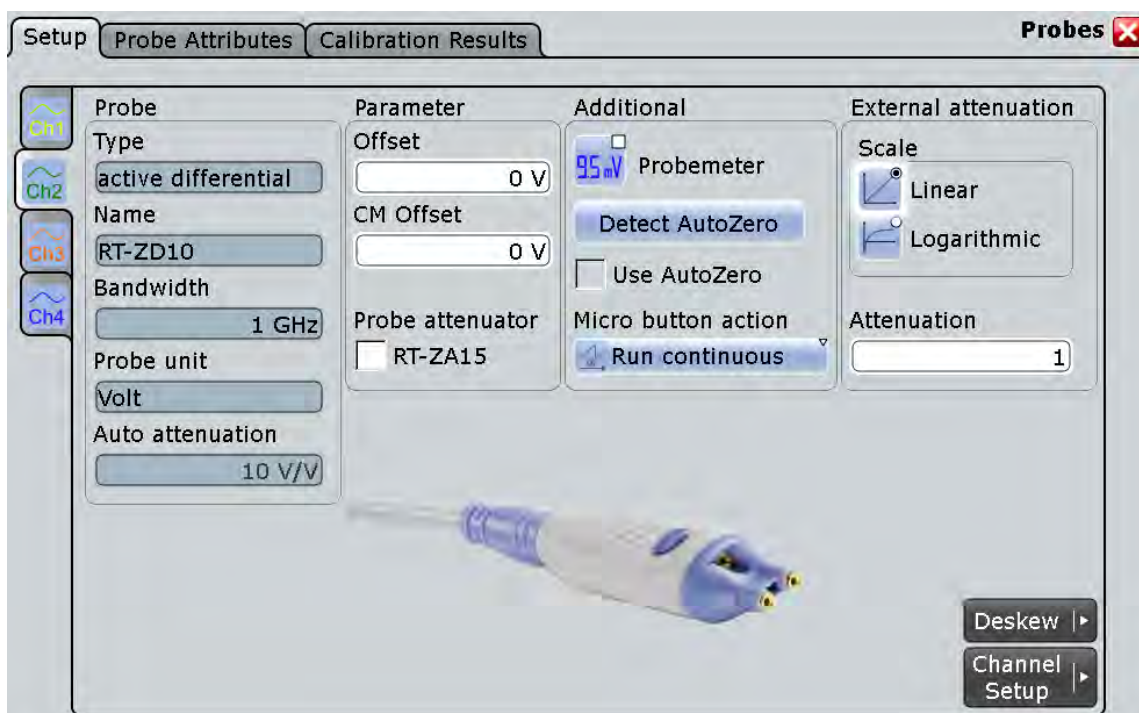

Fig. 3-10: Probe setup for active differential probes

The information on the probe is shown under "Probe", see "Type, Name, Bandwidth, Probe unit, Auto attenuation" on page 121.

The settings for external attenuation are the same as for passive probes, see "External attenuation: Scale, Attenuation" on page 121.

Specific settings for active single-ended and differential probes are:

Offset.....	123
CM offset.....	123
Probe attenuator RT-ZA15.....	124
ProbeMeter.....	124
Detect AutoZero, Use AutoZero.....	125
Micro button action.....	125

Offset

See "Offset" on page 117.

For differential probes, this offset is the differential offset.

CM offset

Sets the common-mode offset.

The setting is only available for differential probes.

Remote command:

PROBe<m>: SETup:CMOffset on page 695

Probe attenuator RT-ZA15

If you use the external attenuator R&S RT-ZA15 together with one of the differential active probes R&S RT-ZD10/20/30, enable RT-ZA15 to include the external attenuation in the measurements.

Remote command:

`PROBe<m>:SETup:ZA15` on page 694

ProbeMeter

The integrated R&S ProbeMeter of active R&S probes (except for RT-ZS10E) is a voltmeter that measures DC voltages between the probe tip and ground connection or between the probe tips with very high precision. The R&S ProbeMeter enables ground-referenced measurements of voltages. The measurement is performed continuously and in parallel to the measurements of the oscilloscope.

- **ProbeMeter measurement results of single-ended active R&S probes**

Measures the voltage between the probe tip and the ground.

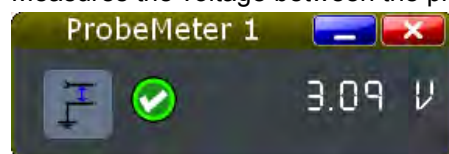

- **ProbeMeter measurement results of differential active R&S probes**

You can select the voltage to be measured by the differential active probe:

- "Differential / Common Mode":

Differential voltage is the voltage between the positive and negative signal sockets.

Common mode voltage is the mean voltage between the signal sockets and the ground socket. It measures the voltage level relative to ground, for example, to check the operating voltage window.

See also: "[Differential active probes](#)" on page 100.

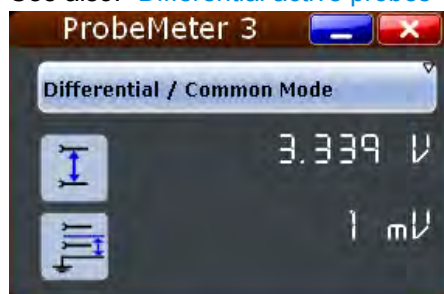

- "Single Ended Pos/Neg": Measures the voltage between the positive/negative signal socket and the ground.

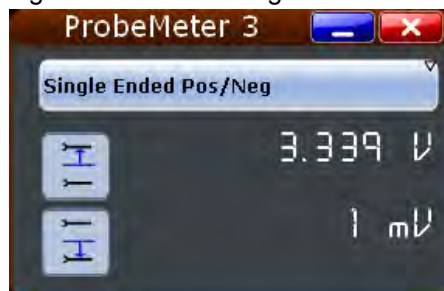

The ProbeMeter always measures the common mode and differential voltages. Single-ended voltages are calculated values:

$$V_p = V_{cm} + 0,5 * V_{in} \text{ and } V_n = V_{cm} - 0,5 * V_{in}$$

Remote command:

`PROBe<m>:SETup:DISPlaydiff` on page 698

Detect AutoZero, Use AutoZero

Differences in DUT and oscilloscope ground levels may cause larger zero errors affecting the waveform. If the DUT is ground-referenced, the AutoZero function corrects the zero error of the probe to optimize measurement results at small signal levels. The validation limit depends on the probe attenuation because probes with high attenuation often have to compensate high offsets. AutoZero detects offset values even when the signal is out of the current measurement range.

To correct the zero error, short the signal pin and the ground pin together and connect them to the ground of the DUT. Then tap "Detect AutoZero".

To include this additional offset in measurement results, enable "Use AutoZero".

Remote command:

`PROBe<m>:SETup:OFFSet:AZERo` on page 694



Micro button action

Active R&S probes (except for RT-ZS10E) have a configurable Micro Button on the probe head. Pressing this button, you can perform an action on the instrument directly from the probe. During internal automatic processes the button is disabled, for example, during self alignment, autoset, and find level.



Select the action that you want to start from the probe:



"Run Continuous"

is the default assignment. The acquisition is running as long as you press the micro button again.



"Run single"

Starts one acquisition.



"Auto set"

Starts the autoset procedure.



"AutoZero"

See: "[Detect AutoZero, Use AutoZero](#)" on page 125.



"Set offset to mean"

Performs an automatic compensation for a DC component of the input signal using the result of a background mean measurement.



"Print"

Prints the current display according to the "Printer control" settings in the "Print" dialog box, see [chapter 11.3, "Reference for PRINT Settings"](#), on page 387. Depending on the selected printer, you can print to a local or network driver, or save to a file.

"Save image to file"

Saves the current display as image according to the image settings in the "Print" dialog box, see [chapter 11.3, "Reference for PRINT Settings"](#), on page 387.

"No action" Select this option to prevent unwanted actions due to unintended usage of the micro button.

Remote command:

`PROBe<m> : SETup : MODE` on page 695

3.3.3.3 Setup for Predefined Probes

Some probes cannot be detected, but their characteristics are known to the R&S RTO. These probes are called "Predefined probes".

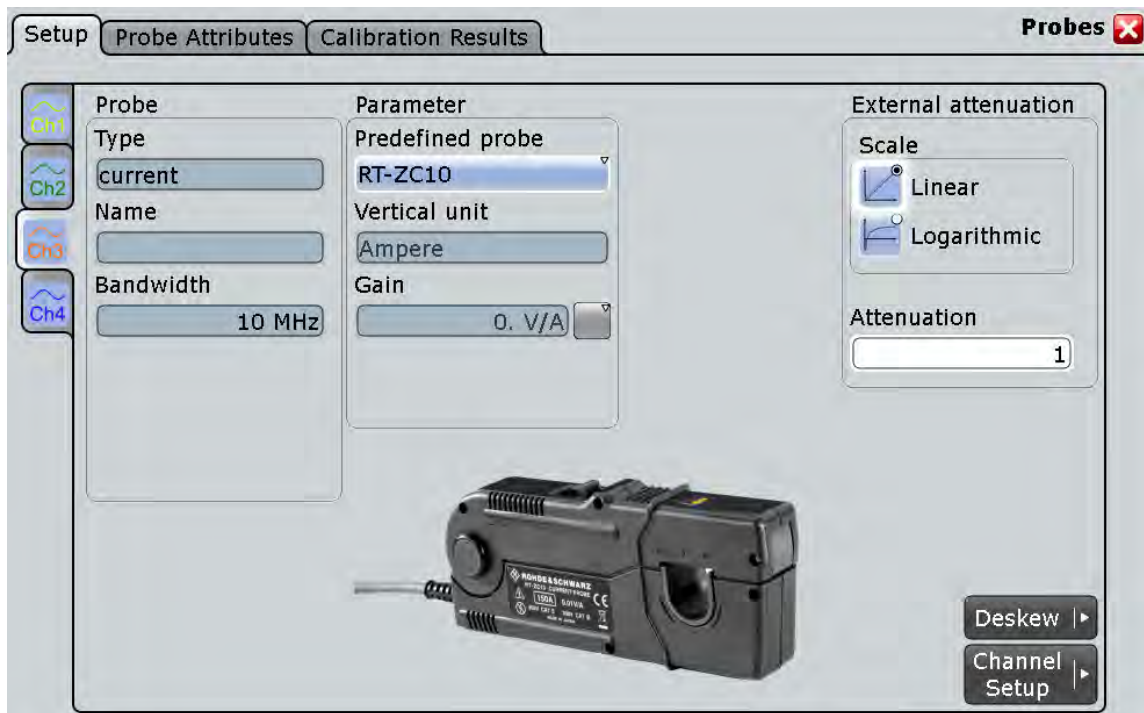

Fig. 3-11: Probe setup for current probes

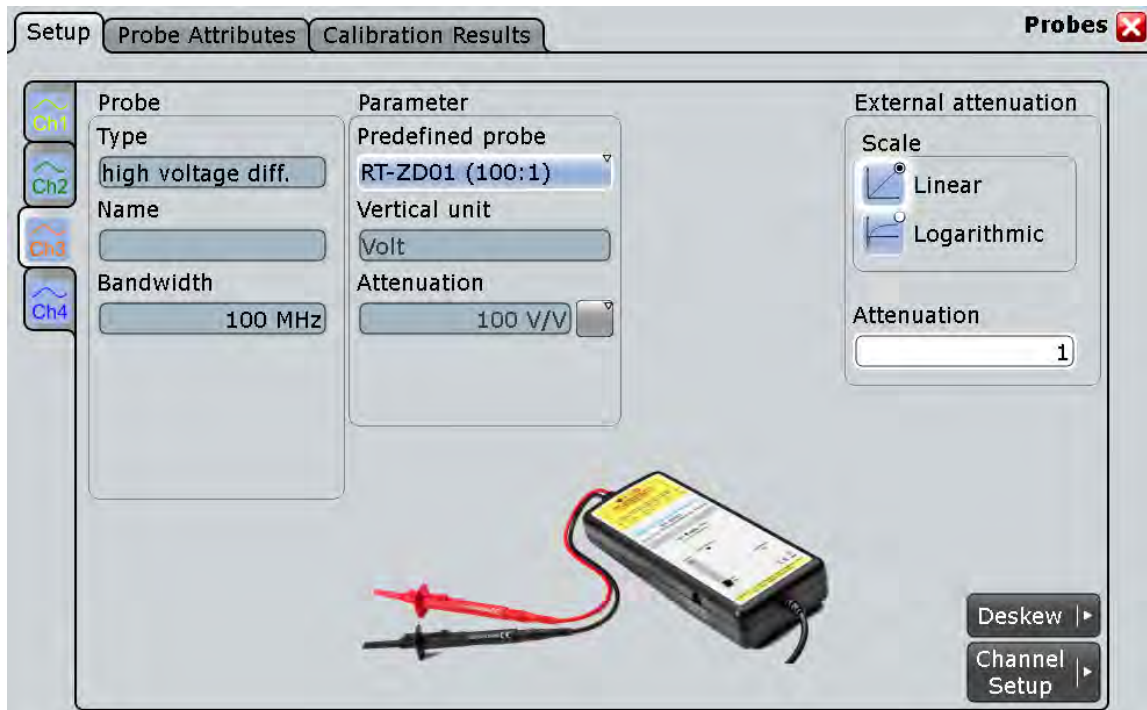

Fig. 3-12: Probe setup for R&S RT-ZD01

Predefined probe

Current probes R&S RT-ZCxx, the high voltage active probe R&S RT-ZD01 and the transmission line probe R&S RT-ZZ80 are not recognized automatically but the parameters of these probes are known to the instrument. Select the correct probe type and enter additional parameters if required. The correspondent "Vertical unit" and the "Attenuation" or "Gain" are set.

For any other unrecognized probe, set "Predefined probe" to "None" and enter the "Vertical unit" and the "Manual attenuation" or "Manual gain".

Remote command:

`PROBe<m>:SETup:ATTenuation:DEFProbe` on page 692

3.3.3.4 Probe Attributes

The "Probe Attributes" tab provides an overview of all R&S probes connected to an input channel.

For a specification of the probe parameters refer to the data sheet.

Attributes	Channel 1	Channel 2	Channel 3	Channel 4
Type	active single-ended	active differential	Passive Probe	None
Name	RT-ZS30	RT-ZD10		
Ext. Attenuator	Empty	RT-ZA15	Empty	Empty
Serial No	990031	200011	---	---
Probe attenuation	10:1	10:1	10:1	---
Part number	1410.4309.02	1410.4715.02	---	---
Software version	2.3.19424.1623	2.5.20784.51947	---	---
Input unit	V	V	---	---
Bandwidth	---	1 GHz	---	---
Input capacitance	800 fF	600 fF	---	---
Input impedance	1 MΩ	1 MΩ	---	---
Dynamic DC range max	8 V	50 V	---	---
Dynamic DC range min	-8 V	-50 V	---	---
Offset range max	12 V	50 V	---	---
Offset range min	-12 V	-50 V	---	---

SCPI commands:

- [PROBe<m>:ID:SWVersion?](#) on page 698
- [PROBe<m>:ID:PRDate?](#) on page 698
- [PROBe<m>:ID:PARTnumber?](#) on page 698
- [PROBe<m>:ID:SRNumber?](#) on page 699

3.3.3.5 Calibration Results

The "Calibration Results" tab provides the calibration data stored in the probe for all R&S probes connected to an input channel.

Calibration	Channel 1	Channel 2	Channel 3	Channel 4
Probe group delay	5 ns	5 ns	---	---
Probe internal offset	-12.5 μV	53.685 μV	---	---
Attenuation	10.6565862:1	10.3691588:1	10:1	---

3.3.4 Digital Filter Setup

After processing by the A/D converter, the channel and trigger signals are digitized signals. These digitized signals can be filtered to reject high frequency - also known as Digital Signal Processing (DSP). You can filter the acquisition channels as well as the trigger channel signal.

If you filter only the input channels, you can apply different filters - one filter for channels 1 and 2 and - for 4-channel models - another filter for channels 3 and 4.

If you filter the trigger channel, the same filter must be used for the input channels to ensure that all signals suit for analysis. The instrument offers only permitted combinations and triggers on the filtered signal.

Example:

RF reject for the trigger signal ensures that triggering will not be caused by unexpected glitches.

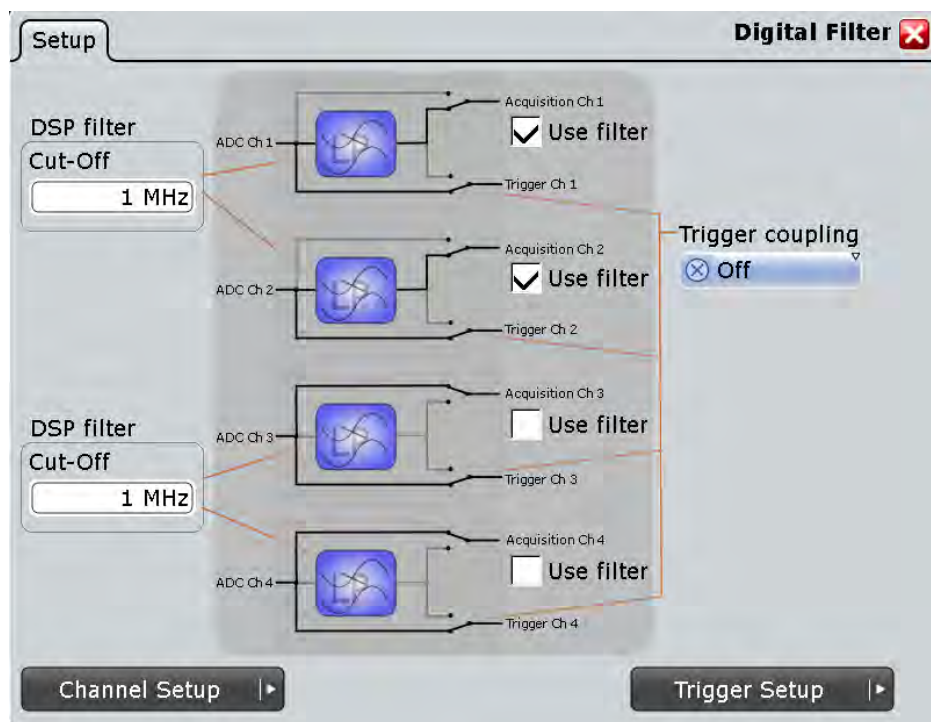

Use filter

Enables the DSP filter.

The number of filters depends on the instrument model:

- R&S RTO1022 and R&S RTO1024 have a filter for each input channel.
- R&S RTO1012 and R&S RTO1014 have filters affecting two channels: One filter for Ch1 and Ch2, and the second filter for Ch3 and Ch4 (R&S RTO1014 only).

Remote command:

[CHANnel<m>:DIGFilter:STATE](#) on page 699

Cut-off

Sets the limit frequency of the Lowpass filter for input channels.

The filter value is applied to two channels in R&S RTO1022 and R&S RTO1024, or applied to all available channels in R&S RTO1012 and R&S RTO1014.

Remote command:

[CHANnel<m>:DIGFilter:CUToff](#) on page 699

Trigger coupling

Selects the filter for the trigger channel(s). Other channels must use the same filter, or proceed unfiltered.

"Off" The trigger signal is not filtered, and the acquisition channels can be filtered independently.

"RF reject" frequencies higher than the "RF reject BW" are rejected, lower frequencies pass the filter.

Remote command:

[TRIGger<m>:COUPling](#) on page 700

RF reject BW

Sets the limit frequency for "RF reject" trigger coupling. This limit is applied to the trigger channel and to the acquisition channels enabled for filtering.

Remote command:

[TRIGger<m>:RFRej ect<n>](#) on page 700

3.3.5 Horizontal Accuracy

The Horizontal Accuracy contains standard and optional settings to improve measurement and analysis accuracy and to reduce jitter effects.

3.3.5.1 Reference (OCXO, Option RTO-B4)

The option RTO-B4 provides an Oven Controlled Crystal Oscillator (OCXO) that produces a 10 MHz internal reference signal with very precise and stable frequency. With this option, you can also use an external reference signal. The input and output connectors for the external reference signal are located on the rear panel alongside the external trigger input.

Detected

Indicates if the OCXO option is installed and detected by the instrument.

Oven hot

Indicates when the oven has reached its nominal temperature and is operating with the specified accuracy.

External reference

Sets the frequency of an external reference input signal that is connected to the external reference input on the rear panel of R&S RTO. A frequency range from 1 MHz to 20 MHz is supported.

Remote command:

[SENSe\[:ROSCillator\]:EXTernal:FREQuency](#) on page 701

Use external reference

Enables the use of the external reference signal instead of the internal OCXO reference.

If an external reference is used, the frequency of the reference output signal is the same as of the reference input signal. Otherwise, the frequency of the reference output signal is 10 MHz, that is the frequency of the OCXO.

Remote command:

[SENSe\[:ROSCillator\]:SOURce](#) on page 701

3.3.5.2 Skew

Skew compensates signal propagation differences between channels caused by the different length of cables, probes, and other sources. Correct skew values are important for accurate triggering and timing relations between channels.



Make sure that the correct channel tab is selected.

Show channel

Switches the channel signal on or off. The signal icon appears on the signal bar. The waveform of the last acquisition is displayed in the diagram.

Remote command:

[CHANnel<m>:STATe](#) on page 685

Use skew offset

If enabled, the "Skew offset" value is used for compensation. This improves horizontal and trigger accuracy.

Remote command:

[CHANnel<m>:SKEW:MANual](#) on page 700

Skew offset

Sets an delay value, that is known from the circuit specifics but cannot be compensated by the instrument automatically. It affects only the selected input channel.

Remote command:

[CHANnel<m>:SKEW:TIME](#) on page 701

3.3.5.3 AUX OUT

1 GHz Reference ON

Enables the 1 GHz reference signal and sends it to the AUX OUT connector at the front panel. The signal is required for performance test to measure the frequency internal calibration signal.

4 Triggers

4.1 Basics of Triggering

Triggering means to capture the interesting part of the relevant waveforms. Choosing the right trigger type and configuring all trigger settings correctly allows you to detect various incidents in analog, digital, and logic signals.

Trigger

A trigger occurs if the complete set of trigger conditions is satisfied. It is the determining point in the waveform record. The instrument acquires continuously and keeps the sample points to fill the pre-trigger part of the waveform record. When the trigger occurs, the instrument continues acquisition until the post-trigger part of the waveform record is filled. Then it stops acquiring and waits for the next trigger. When a trigger is recognized, the instrument will not accept another trigger until the acquisition is complete and the holdoff time has expired.

Trigger conditions

A simple set of trigger conditions includes:

- Source of the trigger signal, its coupling and filtering
- Trigger type and its setup
- Horizontal position of the trigger: trigger offset
See also: [chapter 3.1.3.2, "Horizontal Position"](#), on page 96
- Trigger mode

The R&S RTO provides various trigger types for troubleshooting and signal analysis, for example, edge trigger, glitch trigger, interval trigger, slew rate trigger, and pattern trigger.

For complex tasks like verifying and debugging designs, advanced trigger settings are available:

- Hysteresis, that is the rejection of noise to avoid unwanted trigger events caused by noise
- Holdoff to define exactly which trigger event will cause the trigger
- Qualification to consider the states of digital signals on other input channels and their logical combination
- Trigger sequences to combine two events

Trigger event

In particular for advanced trigger settings, it is important to distinguish between the trigger and the event. An event is the fulfillment of the event conditions, but an event may not be the trigger. Only if the additional criteria are met - hysteresis, holdoff, and/or additional events in a trigger sequence - the trigger occurs.

Event-specific conditions are:

- Trigger source
- Trigger type and its setup
- Qualification

Trigger sequence

A complex trigger sequence joins two separate events with a delay time and a reset time or reset event. This combination is called "A → B → R" trigger sequence. Similar setups are also known as multi-step trigger or A/B trigger.

The combination of one event with holdoff conditions defines a simple "A only" sequence.

Trigger information

Information on the most important trigger settings are shown in the trigger label on top of the signal bar. If you double-tap the trigger label, the "Trigger" dialog box opens. The label shows:

- Trigger mode
- Trigger type, edge/polarity and trigger source, for A- and B-event
- Trigger level

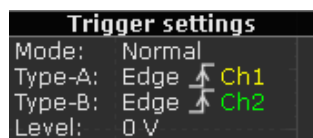

When no trigger has been found for longer than one second, a message box appears that shows the current state of the trigger. For long time bases, the state indicates the remaining pretrigger time, the waiting time if no trigger occurs, and after the trigger the time until the acquisition is completed. While waiting for the trigger, the "Force trigger" button is available to get a waveform quickly. You can also drag the message box to the signal bar.

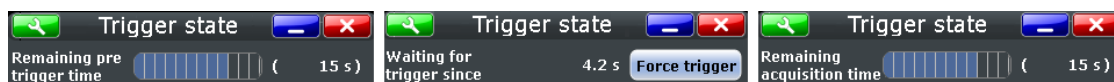

External trigger input, analog and digital trigger system

In R&S RTO, the trigger types use either an analog or a digitized signal as the trigger signal.

If the trigger source is a channel input, the trigger types use a digitized signal. The trigger system of the instrument is a separate system, thus the signal processing by enhancement, decimation and arithmetic has no impact on the trigger signal. Most of the R&S RTO trigger types use the digitized trigger signal.

If the trigger source is the EXT TRIGGER INPUT on the rear panel, the analog edge trigger is available that uses directly the analog input signal. For this analog trigger signal, qualification and the "A → B → R" sequence are not available.

4.2 Setting Up the Trigger

This chapter provides step-by-step procedures for the important stages of trigger setup. The dialog boxes and settings are described in detail in [chapter 4.3, "Reference for Triggers"](#), on page 137.

4.2.1 Configuring the Trigger Event

Prerequisites:

- Horizontal and vertical settings are set appropriately to the signals.
- The acquisition is running, the RUN CONT key lights green.

For details on event settings, see [chapter 4.3.1, "Events and Trigger Types"](#), on page 138.

Proceed as follows:

1. Press the TRIGGER key on the front panel.
The "Trigger" dialog box opens with the "Events" tab.
2. At the left hand-side, select the vertical tab of the event you want to set up: "A Trigger", "B Trigger", or "R Trigger".
3. Tap the "Source" button and select the trigger source.
4. Check the trigger coupling and filter settings. To change the settings, tap the "Channel Setup" button and "Digital Filter" button.
If the trigger source is "Extern", you can adjust the coupling and filters directly in the "Events" tab.
5. Tap the "Type" button and select the trigger type.
6. Under "Trigger type dependent settings", configure the settings for the selected trigger type.
To let the instrument find the trigger level, tap "Find level".
See: [chapter 4.3.1, "Events and Trigger Types"](#), on page 138
7. If you want to set the "Normal" trigger mode, do either of the following:
 - Press the AUTO/NORMAL key on the front panel until NORMAL lights up.
 - Tap the "Normal" button in the "Control" tab.

4.2.2 Positioning the Trigger

By positioning the trigger on the time axis, you define which part of the waveform is displayed: mainly the pre-trigger part, or the post-trigger part, or the part around the trigger point.

For details on position settings, see [chapter 4.3.5, "Horizontal Position"](#), on page 171.

1. Press the TRIGGER key and select the "Hor. Position" tab.
Alternatively, tap the "Trigger" menu and then "Trigger Position".
2. Set the "Reference point" and the "Horizontal position".
If you want to set the trigger position outside the waveform display, make sure that "Restrict horizontal position to acquisition range" is disabled.

4.2.3 Using Holdoff

Holdoff conditions define a waiting time after the current trigger until the next trigger can be recognized. Holdoff is an optional setting to the A-event. You find the holdoff settings in the "Sequence" tab with "A only" trigger sequence selected.

For details on holdoff settings, see ["Holdoff mode"](#) on page 168.

1. Press the TRIGGER key and select the "Sequence" tab.
Alternatively, tap the "Trigger" menu and then "Trigger Sequence".
2. Select the "Trigger sequence": "A only".
3. Select the "Holdoff mode".
4. Enter the "Holdoff settings" belonging to the selected mode.

4.2.4 Setting Up a Trigger Sequence

The complete configuration of a complex "A → B → R" trigger sequence consists of:

- A-event setup
- B-event setup in the same way as for the A-event
- Optional delay time to connect the A- and B-event
- Optional reset by timeout and/or R-trigger

For details on sequence settings, see [chapter 4.3.4, "Sequence"](#), on page 167.

1. Press the TRIGGER key and select the "Sequence" tab.
Alternatively, tap the "Trigger" menu and then "Trigger Sequence".
2. Select the type of the "Trigger sequence": "A → B → R".
3. Tap the "A Event Setup" button and set up the first event.
See: [chapter 4.2.1, "Configuring the Trigger Event"](#), on page 135.
4. In the "Events" tab, select the "B Trigger" tab and set up the edge trigger. Other trigger types are not available for the B-event.
5. Select the "Sequence" tab.
6. Optionally, set the "Delay" the instrument waits after an A event until it recognizes B events.
7. Set the "B event count". The last B event causes the trigger.

8. Additionally, you can define a reset condition: "Enable reset by timeout" and/or "Enable reset event". The sequence restarts with the A-event if no B-event occurs and the reset condition is fulfilled.
 - a) If "Enable reset by timeout" is selected, enter the time in "Reset timeout".
 - b) If "Enable reset event" is selected, tap the "R Event Setup" button and set up the reset event.The trigger types and settings are restricted dependent on the A and B event settings. The instrument provides only possible, reasonable combinations.

4.2.5 Qualifying the Trigger

Qualification considers the states of digital signals on other input channels and their logical combination as an additional trigger event condition. For example, an edge trigger is configured for channel 1, and the instrument triggers only if the signal on channel 2 is high.

If the trigger source is "Extern", qualification is not available.

For details on qualification settings, see [chapter 4.3.2, "Trigger Qualification"](#), on page 163.

1. Press the TRIGGER key and select the [Trigger Qualification](#) tab. Alternatively, tap the "Trigger" menu and then "Trigger Qualification".
2. At the left hand-side, select the vertical tab of the event you want to qualify: "A Trigger", or "B Trigger". For the R-event, qualification is not available.
3. Select the channel(s) with the digital input signal to be used as qualifying signal(s). Channels used as trigger source for the current event cannot be used for qualification and appear dimmed.
4. Check and set the trigger levels for all used channels, that is, the thresholds for digitization of analog signals. You can set all levels to the currently selected value if you select "Couple levels".
5. Set the boolean operation for each channel.
6. If more than one channel is selected, set the logical combination of the channel states.
7. Tap "Qualify" to enable the qualification.

4.3 Reference for Triggers

The setup of a trigger contains mandatory and optional settings. The usage of optional settings depends on the signal characteristics and the test setup.

Mandatory settings are:

- Trigger source: ["Source"](#) on page 139

- Trigger type and its setup: ["Type"](#) on page 140
This is the critical part of the oscilloscope setup to capture the relevant part of the waveform.
- Trigger mode: ["Trigger mode"](#) on page 174
- Trigger position: [chapter 4.3.5, "Horizontal Position"](#), on page 171

Optional settings are:

- Noise rejection settings: [chapter 4.3.3, "Noise Reject"](#), on page 166
- Trigger sequence, a combination of two trigger events: [chapter 4.3.4, "Sequence"](#), on page 167
- Qualification: combination of the trigger signal with the state of other channel signals: [chapter 4.3.2, "Trigger Qualification"](#), on page 163
- Digital Filter Setup: additional filtering of the trigger signal: [chapter 3.3.4, "Digital Filter Setup"](#), on page 128

4.3.1 Events and Trigger Types

The setup of the trigger type is the most important part of the trigger definition. It determines the method to identify specific signal phenomena. In principle, all trigger types are available for all events in a trigger sequence, that is, you can combine different types with A-, B-, and R-event. The instrument checks the trigger settings for compatibility and feasibility and disables settings that do not fit the previous settings in the sequence.



Make sure that the correct trigger tab is selected on the left before you enter the settings.

The settings in the "Event" tab are:

• Basic Trigger Settings	139
• Edge	142
• Analog Edge	143
• Glitch	145
• Width	146
• Runt	147
• Window	149
• Timeout	150
• Interval	151
• Slew Rate	152
• Data2Clock	154
• State	155
• Pattern	156
• Serial Pattern	157
• NFC Trigger	159
• TV/Video Trigger	159

- [CDR Trigger](#)..... 163
- [Triggering on Serial Buses](#)..... 163
- [Triggering on Parallel Buses and Digital Channels](#)..... 163

4.3.1.1 Basic Trigger Settings

The basic trigger settings are the trigger source and the trigger type, including the trigger level. These settings are specific for each event in a trigger sequence, that is, specific for A-, B- and R-events. For the trigger source, the current ground/coupling settings are displayed, filtering is also possible.

Additionally, you can let the R&S RTO find the trigger level, set the trigger levels to the same value for all channels and enable trigger qualification. These settings are located under "Trigger type dependent settings".

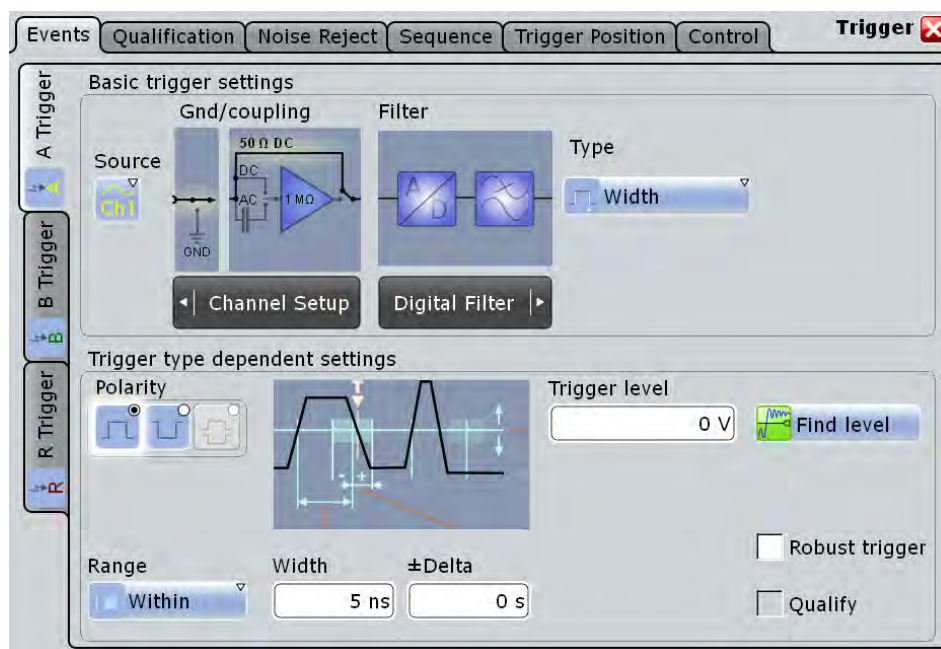

Source

Selects the source of the trigger signal for the current trigger event. The source can be one of the input channels, a serial bus, or an external analog signal connected to the External Trigger Input on the rear panel. The trigger source works even if it is not displayed in a diagram. It should be synchronized to the signal to be displayed and analyzed.

If options with trigger functionality are installed, the variety of trigger sources of the A-event setup is enhanced with specific trigger sources - Serial bus for protocol analysis, and digital channels as well as parallel buses for mixed signal option (see "[Source](#)" on page 525).

Available sources depend on the trigger sequence setting. If the trigger sequence "A → B → R" is selected, only channel inputs Ch1...4 can be set as trigger source, and all other input sources are disabled. If "A only" is selected, all inputs (input channels, serial and parallel buses, digital channels etc.) can be used as trigger source. See also: [chapter 4.3.4, "Sequence"](#), on page 167

The external trigger source is supported for the A-event. It is not available if the trigger sequence "A → B → R" is selected, or if qualification is enabled.

Remote command:

[TRIGger<m>:SOURce](#) on page 702

Type

Selects the trigger type specific for each event in a trigger sequence. The current trigger type is shown on the button.

The following trigger types are available:

- [Edge, see page 142](#)
- [Glitch, see page 145](#)
- [Width, see page 146](#)
- [Runt, see page 147](#)
- [Window, see page 149](#)
- [Timeout, see page 150](#)
- [Interval, see page 151](#)
- [Slew Rate, see page 152](#)
- [Data2Clock, see page 154](#)
- [chapter 4.3.1.12, "State", on page 155](#)
- [Pattern, see page 156](#)
- [Serial Pattern, see page 157](#)
- [chapter 4.3.1.16, "TV/Video Trigger", on page 159](#)
- [chapter 16.4, "NFC Trigger", on page 543 \(requires option R&S RTO-K11\)](#)
- [chapter 17.2.2.2, "CDR Trigger", on page 556 \(requires option R&S RTO-K13\)](#)

Restrictions:

- If the external trigger input is used as trigger source, the analog edge trigger is the only available trigger type.
- For the B-event, only edge trigger is available.
- For the R-event (reset), the trigger types and settings are restricted dependent on the A and B event settings. The instrument provides only possible, reasonable combinations.

Remote command:

[TRIGger<m>:TYPE](#) on page 703



Find level

Sets the trigger level automatically to $0.5 * (MaxPeak - MinPeak)$. The function is not available for an external trigger source and the TV trigger.

Remote command:

[TRIGger<m>:FINDlevel](#) on page 705

Qualify

Enables the settings for trigger qualification that are defined in the "Qualification" tab. Qualification adds additional trigger conditions considering the logic states of other digital channel signals.

The checkmark is only active if at least one qualification channel is selected.

Qualification is available for many trigger types: Edge, Glitch, Width, Runt, Window, Timeout, and Interval.

Qualification is not possible for the R-event.

See also: [chapter 4.3.2, "Trigger Qualification"](#), on page 163.

Robust trigger

The "Robust trigger" setting is relevant for all trigger types with an event condition that is based on the time difference between a rising and a falling edge. These trigger types are: glitch, width, runt, timeout, window, data2clock, pattern, and serial pattern. It avoids an undefined state of the trigger system that might occur due to hysteresis, for example, when triggering on the envelope of a modulated signal.

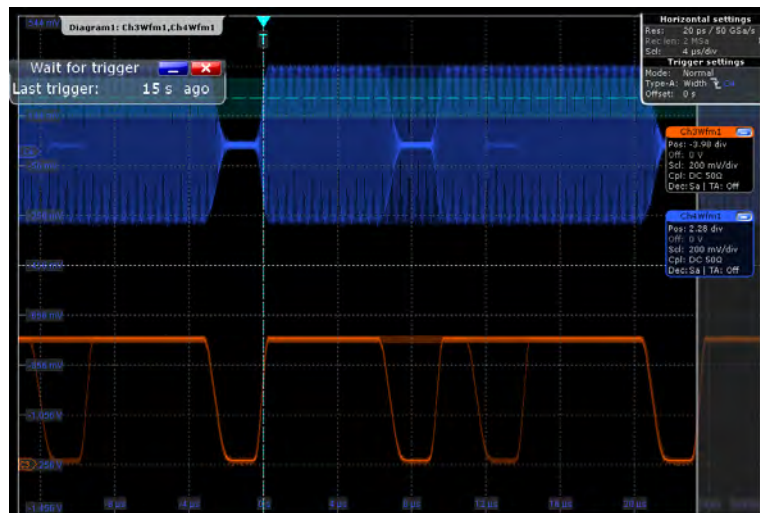
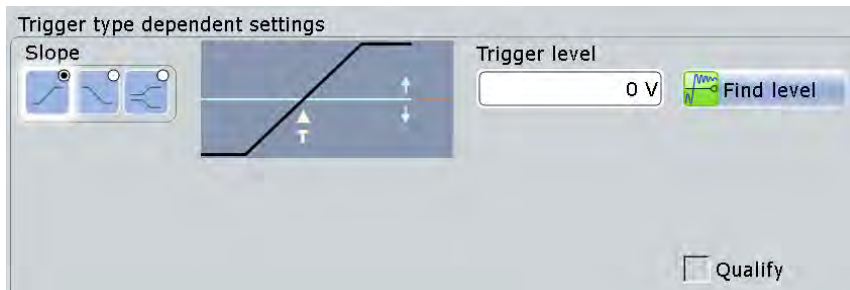

Fig. 4-1: Width trigger on modulated signal - no triggering

If the trigger source is a channel signal, the edge trigger uses the digitized trigger signal. This signal can be qualified and filtered with the DSP filter. If the trigger source is the EXT TRIGGER INPUT, the analog trigger signal is used, and the coupling and filter for this signal is set directly in the trigger setup.



Slope

Sets the edge type for the trigger event.



"Positive"

Selects the rising edge, that is a positive voltage change.



"Negative"

Selects the falling edge, that is a negative voltage change.

"Both"

Selects the rising as well as the falling edge. This option is not available if the trigger source is the external trigger input.

Remote command:

[TRIGger<m>:EDGE:SLOPe](#) on page 706

[TRIGger<m>:ANEDge:SLOPe](#) on page 709

[TRIGger<m>:SLEW:SLOPe](#) on page 719

Trigger level

Sets the voltage level for the trigger event. You can also drag the trigger level marker on the display (TA or TB on the right edge of the display).

Remote command:

[TRIGger<m>:LEVel<n>\[:VALue\]](#) on page 704

4.3.1.3 Analog Edge

The analog edge trigger is available for trigger source signals connected to the external trigger input on the rear panel of the instrument. This trigger type uses directly the analog input signal.

The "Find level" function is not available for analog trigger signals.



Ground

If the selected trigger source is the external trigger input, you can connect the trigger input to the ground.

Remote command:

[TRIGger<m>:ANEDge:GND](#) on page 708

**Coupling**

If the selected trigger source is the external trigger input, the analog trigger signal is used, and you can set the coupling for this input.



"DC 50 Ω" Direct connection with 50 Ω termination, passes both DC and AC components of the trigger signal.



"DC 1 MΩ" Direct connection with 1 MΩ termination, passes both DC and AC components of the trigger signal.

"AC" Connection through capacitor, removes unwanted DC and very low-frequency components.

Remote command:

[TRIGger<m>:ANEDge:COUPling](#) on page 707

Filter

If the selected trigger source is the external trigger input, the analog trigger signal is used for triggering, and you can directly select an additional filter to reject high or low frequencies.

For all trigger types using the digitized signal, you can add a digital filter using the Digital Filter Setup. See: [chapter 3.3.4, "Digital Filter Setup"](#), on page 128.

"Off" The trigger signal is not filtered.

"Highpass" Frequencies below the "Cut-off" frequency are rejected, higher frequencies pass the filter.
You can adjust the "Cut-off" frequency, the default is 50 kHz.

"Lowpass" Frequencies higher than the "Cut-off" frequency are rejected, lower frequencies pass the filter.
You can adjust the "Cut-off" frequency, the default is 50 kHz.

Remote command:

[TRIGger<m>:ANEDge:FILTer](#) on page 708

[TRIGger<m>:ANEDge:CUToff:HIGHPass](#) on page 707

[TRIGger<m>:ANEDge:CUToff:LOWPass](#) on page 707

**Slope**

Sets the edge type for the trigger event.



"Positive" Selects the rising edge, that is a positive voltage change.



"Negative" Selects the falling edge, that is a negative voltage change.

"Both" Selects the rising as well as the falling edge. This option is not available if the trigger source is the external trigger input.

Remote command:

[TRIGger<m>:EDGE:SLOPe](#) on page 706

[TRIGger<m>:ANEDge:SLOPe](#) on page 709

[TRIGger<m>:SLEW:SLOPe](#) on page 719

Trigger level

Sets the voltage level for the trigger event. You can also drag the trigger level marker on the display (TA or TB on the right edge of the display). The range of the trigger level is limited in a way so that always a hysteresis for stable trigger conditions is available.

Remote command:

[TRIGger<m>:LEVel<n>\[:VALue\]](#) on page 704

4.3.1.4 Glitch

The glitch trigger event detects pulses shorter or longer than a specified time. It identifies deviation from the nominal data rate and helps to analyze causes of even rare glitches and their effects on other signals.

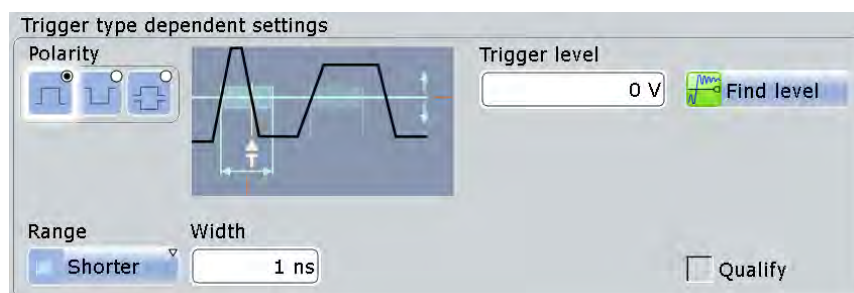
**Polarity**

Indicates the polarity of a pulse, that is the direction of the first pulse slope.



"Positive" Selects positive going pulses.



"Negative" Selects negative going pulses.

"Either" Selects both positive and negative going pulses.

Remote command:

[TRIGger<m>:GLITch:RANGe](#) on page 709

[TRIGger<m>:RUNT:POLarity](#) on page 712

**Range**

Selects which glitches are identified: shorter or longer than the specified "Width".



Remote command:

[TRIGger<m>:GLITch:RANGe](#) on page 709

Width

Sets the length of a glitch. The instrument triggers on pulses shorter or longer than this value. The minimum width is 100 ps.

You need to know the expected pulse widths of the circuit to set the glitch width correctly.

Remote command:

[TRIGger<m>:GLITch:WIDTh](#) on page 710

Trigger level

Sets the voltage level for the trigger event. You can also drag the trigger level marker on the display (TA or TB on the right edge of the display). The range of the trigger level is limited in a way so that always a hysteresis for stable trigger conditions is available.

Remote command:

[TRIGger<m>:LEVel<n>\[:VALue\]](#) on page 704

4.3.1.5 Width

The width trigger detects pulses with a pulse width (duration) inside or outside the allowed time limits. The instrument triggers if the pulse is too long to cross the specified voltage threshold twice, if it is too short, or if it is outside or inside the time range. The pulse width is measured at the trigger level.

Using the width trigger, you can define the pulse width more precisely than with the glitch trigger. However, with range settings "Shorter" and "Longer" you can also trigger on glitches.

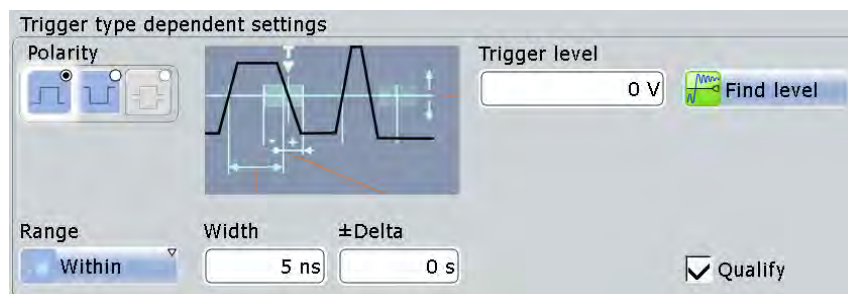

While the width trigger can only analyze **either** positive **or** negative polarity, searching for a width is also possible for both polarities at the same time ("Either").

**Polarity**

Indicates the polarity of a pulse, that is the direction of the first pulse slope.



"Positive" Triggers on positive going pulses.

"Negative" Triggers on negative going pulses.

Remote command:

[TRIGger<m>:WIDTh:POLarity](#) on page 710

[TRIGger<m>:INTerval:POLarity](#) on page 718

**Range**

Selects how the range of a pulse width is defined:



"Within" Triggers on pulses inside a given range. The range of the pulse width is defined by "±Delta" related to "Width".



"Outside" Triggers on pulses outside a given range. The range definition is the same as for "Within" range.



"Shorter" Triggers on pulses shorter than the given "Width".

"Longer" Triggers on pulses longer than the given "Width".

Remote command:

[TRIGger<m>:WIDTh:RANGe](#) on page 711

Width

For the ranges "Within" and "Outside", the width defines the center of a range which is defined by the limits $\pm\Delta$.

For the ranges "Shorter" and "Longer", the width defines the maximum and minimum pulse width, respectively.

Remote command:

[TRIGger<m>:WIDTh:WIDTh](#) on page 711

$\pm\Delta$

Defines a range around the given width value.

The combination "Range" = Within and " $\pm\Delta$ " = 0 triggers on pulses with a pulse width that equals "Width".

The combination "Range" = Outside and " $\pm\Delta$ " = 0 means to trigger on pulse widths \neq "Width".

Trigger level

Sets the voltage level for the trigger event. You can also drag the trigger level marker on the display (TA or TB on the right edge of the display). The range of the trigger level is limited in a way so that always a hysteresis for stable trigger conditions is available.

Remote command:

[TRIGger<m>:LEVel<n>\[:VALue\]](#) on page 704

4.3.1.6 Runt

A runt is a pulse lower than normal in amplitude. The amplitude crosses the first threshold twice in succession without crossing the second one. In addition to the threshold amplitudes, you can define a time limit for the runt in the same way as for width triggers. For example, this trigger can detect logic, digital, and analog signals remaining below a specified threshold amplitude because I/O ports are in undefined state.

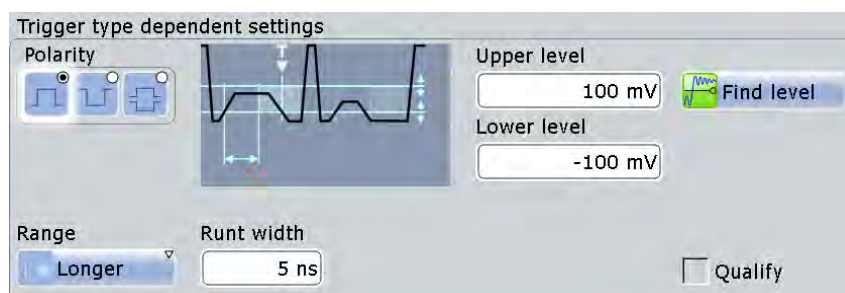

**Polarity**

Indicates the polarity of a pulse, that is the direction of the first pulse slope.



"Positive" Selects positive going pulses.



"Negative" Selects negative going pulses.

"Either" Selects both positive and negative going pulses.

Remote command:

[TRIGger<m>:GLITch:RANGe](#) on page 709

[TRIGger<m>:RUNT:POLarity](#) on page 712

Upper level

Sets the upper voltage threshold.

Remote command:

[TRIGger<m>:LEVel<n>:RUNT:UPPer](#) on page 712

Lower level

Sets the lower voltage threshold.

Remote command:

[TRIGger<m>:LEVel<n>:RUNT:LOWer](#) on page 712

**Range**

Selects how the time limit of the runt pulse is defined:



"Any runt" Triggers on all runts fulfilling the level condition, without time limitation.



"Longer" Triggers on runts longer than the given "Runt width".



"Shorter" Triggers on runts shorter than the given "Runt width".



"Within" Triggers if the runt length is inside a given time range. The range is defined by "Runt width" and " $\pm\Delta$ ".



"Outside" Triggers if the runt length is outside a given time range. The range definition is the same as for "Within" range.

Remote command:

[TRIGger<m>:RUNT:RANGe](#) on page 713

Runt width

For the ranges "Shorter" and "Longer", the runt width defines the maximum and minimum pulse width, respectively.

For the ranges "Within" and "Outside", the runt width defines the center of a range which is defined by " $\pm\Delta$ ".

Remote command:

[TRIGger<m>:RUNT:WIDTh](#) on page 713

 $\pm\Delta$

Defines a range around the given runt width.

Remote command:

[TRIGger<m>:RUNT:DELTA](#) on page 714

4.3.1.7 Window

The window trigger checks the signal run in relation to a "window". The window is formed by the upper and lower voltage levels. The event condition is fulfilled, if the waveform enters or leaves the window, or if the waveform stays inside or outside for a time longer or shorter than specified.

With the window trigger, you can display longer transient effects.

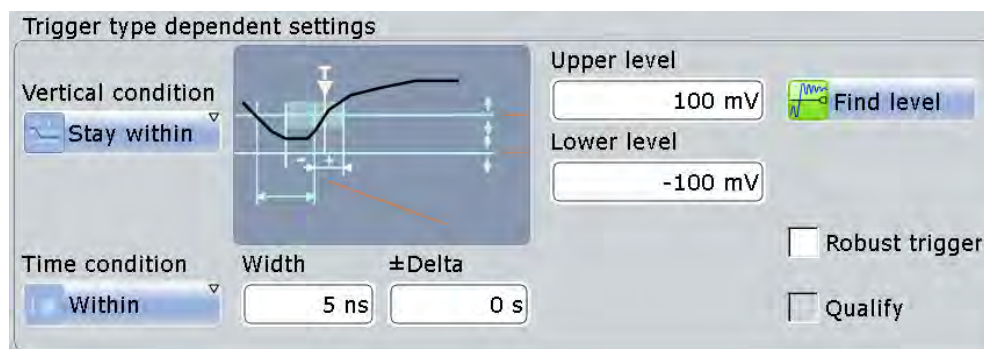

Vertical condition

Selects how the signal run is compared with the window:



"Enter" Triggers when the signal crosses the upper or lower level and thus enters the window made up of these two levels.



"Exit" Triggers when the signal leaves the window.



"Stay within" Triggers if the signal stays between the upper and lower level for a specified time. The time is defined in various ways by the [Time condition](#).

"Stay outside" Triggers if the signal stays above the upper level or below the lower level for a specified time. The time is also defined by the "Time condition".

Remote command:

[TRIGger<m>:WINDow:RANGe](#) on page 715

Upper level

Sets the upper voltage limit for the window.

Remote command:

[TRIGger<m>:LEVel<n>:WINDow:UPPer](#) on page 714

Lower level

Sets the lower voltage limit for the window.



Remote command:

[TRIGger<m>:LEVel<n>:WINDow:LOWer](#) on page 715



Time condition

Selects how the time limit of the window is defined. Time conditioning is available for the vertical conditions "Stay within" and "Stay outside".

	"Within"	Triggers if the signal stays inside or outside the vertical window limits at least for the time $Width - Delta$ and for $Width + Delta$ at the most.
	"Outside"	"Outside" is the opposite definition of "Within". The instrument triggers if the signal stays inside or outside the vertical window limits for a time shorter than $Width - Delta$ or longer than $Width + Delta$.
	"Shorter"	Triggers if the signal crosses vertical limits before the specified "Width" time is reached.
	"Longer"	Triggers if the signal crosses vertical limits after the specified "Width" time is reached.

Remote command:

[TRIGger<m>:WINDow:TIME](#) on page 715

Width

For the ranges "Within" and "Outside", the width defines the center of a time range which is defined by the limits " $\pm Delta$ ".

For the ranges "Shorter" and "Longer", it defines the maximum and minimum time lapse, respectively.

Remote command:

[TRIGger<m>:WINDow:WIDTh](#) on page 716

$\pm Delta$

Defines a range around the "Width" value.

Remote command:

[TRIGger<m>:WINDow:DELTA](#) on page 716

4.3.1.8 Timeout

The timeout trigger event checks if the signal stays above or below the threshold voltage for a specified time lapse. In other words, the event occurs if the trigger source does not have the expected transition within the specified time.

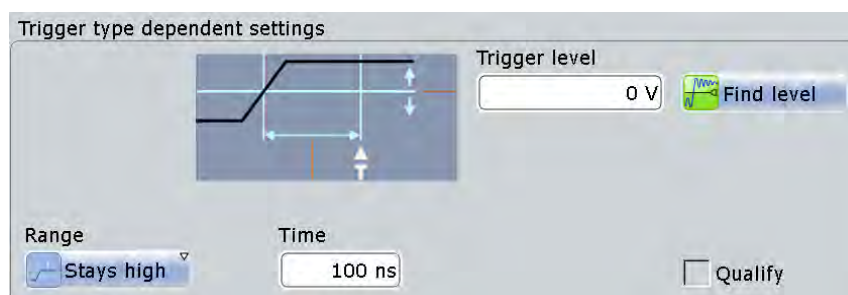

Trigger level

Sets the voltage level for the trigger event. You can also drag the trigger level marker on the display (TA or TB on the right edge of the display). The range of the trigger level is limited in a way so that always a hysteresis for stable trigger conditions is available.

Remote command:

[TRIGger<m>:LEVel<n>\[:VALue\]](#) on page 704

**Range**

Selects the relation of the signal level to the trigger level:



"Stays high" The signal level stays above the trigger level.



"Stays low" The signal level stays below the trigger level.

"High or low" The signal level stays above or below the trigger level.

Remote command:

[TRIGger<m>:TIMEout:RANGe](#) on page 717

Time

Defines the time limit for the timeout at which the instrument triggers.

Remote command:

[TRIGger<m>:TIMEout:TIME](#) on page 717

4.3.1.9 Interval

The interval trigger analyzes the time between two pulses.

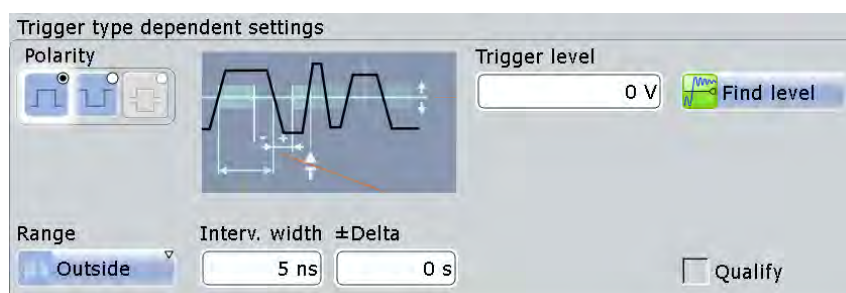

While the interval trigger can only analyze **either** positive **or** negative polarity, searching for an interval is also possible for both polarities at the same time ("Either").

**Polarity**

Indicates the polarity of a pulse, that is the direction of the first pulse slope.



"Positive" Triggers on positive going pulses.

"Negative" Triggers on negative going pulses.

Remote command:

[TRIGger<m>:WIDTH:POLarity](#) on page 710

[TRIGger<m>:INTerval:POLarity](#) on page 718

Trigger level

Sets the voltage level for the trigger event. You can also drag the trigger level marker on the display (TA or TB on the right edge of the display). The range of the trigger level is limited in a way so that always a hysteresis for stable trigger conditions is available.

Remote command:

[TRIGger<m>:LEVel<n>\[:VALue\]](#) on page 704

**Range**

Selects how the range of an interval is defined:



"Within" Triggers on pulse intervals inside a given range. The range is defined by "Interv. width" and " $\pm\Delta$ ".



"Outside" Triggers on intervals outside a given range. The range definition is the same as for "Within" range.



"Shorter" Triggers on intervals shorter than the given "Interv. width".



"Longer" Triggers on intervals longer than the given "Interv. width".

Remote command:

[TRIGger<m>:INTerval:RANGe](#) on page 718

Interv. width

Defines the time between two pulses.

Remote command:

[TRIGger<m>:INTerval:WIDTh](#) on page 718

 $\pm\Delta$

Defines a range around the "Interval width" value.

Remote command:

[TRIGger<m>:INTerval:DELTA](#) on page 719

4.3.1.10 Slew Rate

The slew rate trigger, also known as transition trigger, can detect fast or slow edges selectively. It triggers on edges, if the transition time from the lower to higher voltage level (or vice versa) is shorter or longer as defined, or outside a specified time range.

The trigger event finds slew rates faster than expected or permissible to avoid overshooting and other interfering effects. It also detects very slow edges violating the timing in pulse series.

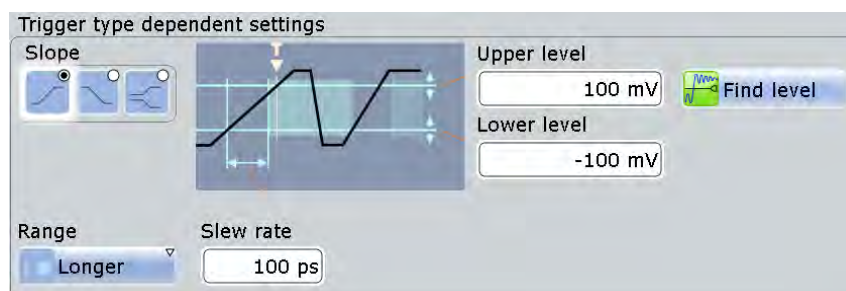

**Slope**

Sets the edge type for the trigger event.



"Positive" Selects the rising edge, that is a positive voltage change.



"Negative" Selects the falling edge, that is a negative voltage change.

"Both" Selects the rising as well as the falling edge. This option is not available if the trigger source is the external trigger input.

Remote command:

[TRIGger<m>:EDGE:SLOPe](#) on page 706

[TRIGger<m>:ANEDge:SLOPe](#) on page 709

[TRIGger<m>:SLEW:SLOPe](#) on page 719

Upper level

Sets the upper voltage threshold. When the signal crosses this level, the slew rate measurement starts or stops depending on the selected slope.

Remote command:

[TRIGger<m>:LEVel<n>:SLEW:UPPer](#) on page 719

Lower level

Sets the lower voltage threshold. When the signal crosses this level, the slew rate measurement starts or stops depending on the selected slope.

Remote command:

[TRIGger<m>:LEVel<n>:SLEW:LOWer](#) on page 720

**Range**

Selects how the time limit for the slew rate is defined. The time measurement starts when the signal crosses the first trigger level - the upper or lower level depending on the selected slope - and stops when the signal crosses the second level.



"Within" Triggers on slew rates inside a given time range. The range is defined by "Slew rate" and " $\pm\Delta$ ".



"Outside" Triggers on slew rates outside a given time range. The range definition is the same as for "Within" range.



"Shorter" Triggers on slew rates shorter than the given "Slew rate" limit.

"Longer" Triggers on slew rates longer than the given "Slew rate" limit.

Remote command:

[TRIGger<m>:SLEW:RANGe](#) on page 720

Slew rate

For the ranges "Within" and "Outside", the slew rate defines the center of a range which is defined by the limits " $\pm\Delta$ ".

For the ranges "Shorter" and "Longer", the slew rate defines the maximum and minimum slew rate limits, respectively.

Remote command:

[TRIGger<m>:SLEW:RATE](#) on page 721

±Delta

Defines a time range around the given slew rate.

Remote command:

[TRIGger<m>:SLEW:DELTA](#) on page 721

4.3.1.11 Data2Clock

With the Data2Clock event - also known as setup/hold - you can analyze the relative timing between two signals: a data signal and the synchronous clock signal. Many systems require, that the data signal must be steady for some time before and after the clock edge, for example, the data transmission on parallel interfaces. With this trigger type, you can also test the time correlation of sideband and inband signals.

The event occurs if the data signal crosses the data level during the setup and hold time. The reference point for the time measurement is defined by clock level and clock edge.

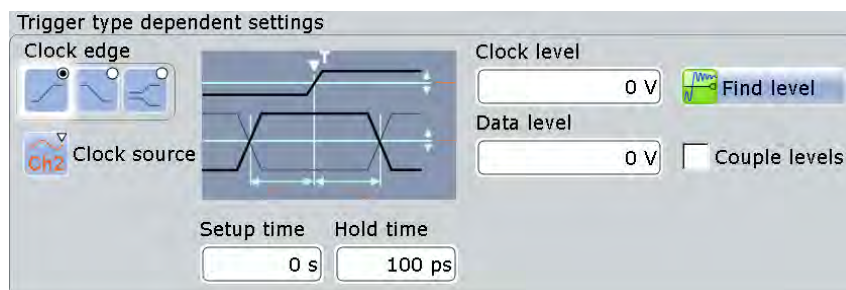
**Clock source**

Selects the input channel of the clock signal.

Remote command:

[TRIGger<m>:DATatoclock:CSOURCE\[:VALUE\]](#) on page 722

[TRIGger<m>:SPATtern:CSOURCE\[:VALUE\]](#) on page 727

**Clock edge**

Sets the edge of the clock signal to define the time reference point for the setup and hold time:



"Positive" Rising edge, a positive voltage change.

"Negative" Falling edge, a negative voltage change.



"Both" Both the rising and the falling edge.

Remote command:

[TRIGger<m>:DATatoclock:CSOURCE:EDGE](#) on page 722

Clock level

Sets the voltage level for the clock signal. Both "Clock level" and "Clock edge" define the starting point for calculation of the setup and hold time.

Remote command:

[TRIGger<m>:DATatoclock:CSOURCE:LEVEL](#) on page 722

Data level

Sets the voltage level for the data signal. At this level, the setup and hold time is measured.

Remote command:

[TRIGger<m>:LEVel<n>\[:VALue\]](#) on page 704

Couple levels (Trigger level and hysteresis coupling)

Sets the trigger levels and hysteresis values for all channels to the values of the currently selected trigger source. The function affects only the levels defined for the selected event (A-, B-, or R-event). The hysteresis of the external trigger input is an independent value, and it is not affected by level coupling.

In trigger sequences, event coupling of trigger levels is possible: "[Couple levels of all events](#)" on page 170

Remote command:

[TRIGger<m>:SCOupling](#) on page 706

Setup time

Sets the minimum time **before** the clock edge while the data signal must stay steady above or below the data level.

The setup time can be negative. In this case, the hold time is always positive. If you set a negative setup time, the hold time is adjusted by the instrument.

Remote command:

[TRIGger<m>:DATatoclock:STIME](#) on page 723

Hold time

Sets the minimum time **after** the clock edge while the data signal must stay steady above or below the data level.

The hold time can be negative. In this case, the setup time is always positive. If you set a negative hold time, the setup time is adjusted by the instrument.

Remote command:

[TRIGger<m>:DATatoclock:HTIME](#) on page 723

4.3.1.12 State

The state trigger is a qualified edge trigger. It combines the edge trigger settings with trigger qualification.

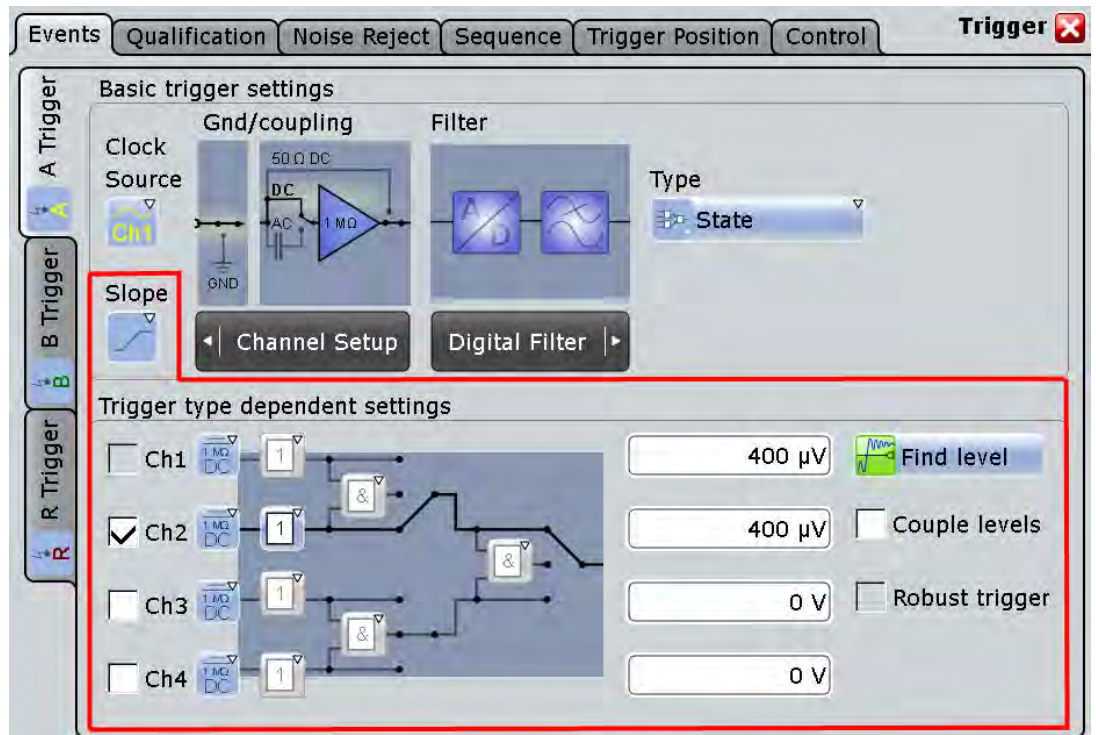

The individual settings are:

- "Slope" on page 143
- "Pattern" on page 164
- "Trigger Levels" on page 165
- "Find level" on page 140
- "Couple levels (Trigger level and hysteresis coupling)" on page 155

Robust triggering is not relevant for the state trigger.

4.3.1.13 Pattern

The pattern trigger is a logic trigger. It provides logical combinations of the input channels and supports you in verifying the operation of digital logic.

The setup of the pattern trigger is very similar to trigger qualification. In addition to the pattern and the trigger levels, you can define a timing condition. The complete settings for the pattern trigger are provided in the "Qualification" tab.

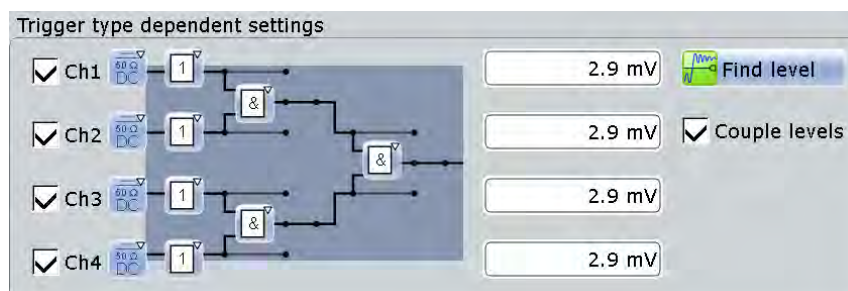

For details on pattern definition, see ["Pattern"](#) on page 164.

Trigger Levels

Defines the trigger levels for all input channels. For qualification and pattern trigger, the trigger level is a decision threshold: If the signal value is higher than the trigger level, the signal state is high (1 or true for the boolean logic). Otherwise, the signal state is considered low (0 or false) if the signal value is below the trigger level.

You can set the trigger levels for all channels to the same value, see ["Couple levels \(Trigger level and hysteresis coupling\)"](#) on page 155.

State timing

"State timing" adds additional time limitation to the state pattern. You find this setting in the "Qualification" tab.

"Off"	No time limitation. The event occurs if the pattern condition is fulfilled.
"Timeout"	Defines how long the result of the state pattern condition must be true or false.
"Width"	Defines a time range for keeping up the true result of the state pattern condition. The range is defined in the same way as for width and interval triggers, see "Range" on page 146.

Remote command:

[TRIGger<m>: PATtern:MODE](#) on page 724

[TRIGger<m>: PATtern:TIMEout:MODE](#) on page 725

[TRIGger<m>: PATtern:TIMEout\[:TIME\]](#) on page 725

[TRIGger<m>: PATtern:WIDTh:DELTA](#) on page 726

[TRIGger<m>: PATtern:WIDTh:RANGe](#) on page 726

[TRIGger<m>: PATtern:WIDTh\[:WIDTh\]](#) on page 726

4.3.1.14 Serial Pattern

The serial pattern event is used to trigger on signals with serial data patterns in relation to a clock signal - for example, on bus signals like the I²C bus.

For convenient and comprehensive triggering on specific serial data, options for serial protocol analysis are provided, see [chapter 14, "Protocol Analysis \(Base Functions and Options R&S RTO-K1 to K5\)"](#), on page 419.

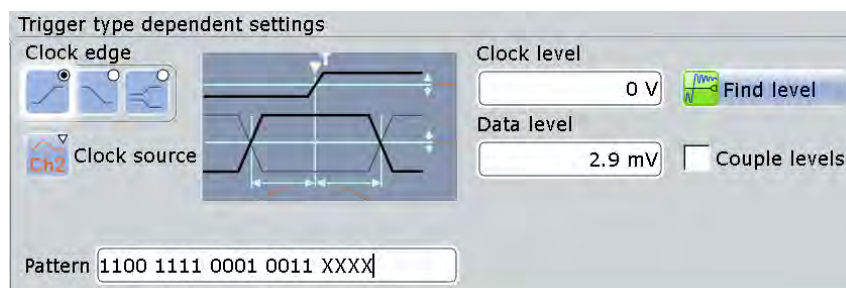

Clock source

Selects the input channel of the clock signal.

Remote command:

[TRIGger<m>:DATAtoclock:CSOurce\[:VALue\]](#) on page 722

[TRIGger<m>:SPATtern:CSOurce\[:VALue\]](#) on page 727

**Clock edge**

Together with the clock level, the clock edge sets the point in time when the state of the data signal is checked:



"Positive" Rising edge, a positive voltage change.



"Negative" Falling edge, a negative voltage change.



"Both" Both the rising and the falling edge.

Remote command:

[TRIGger<m>:SPATtern:CSOurce:EDGE](#) on page 727

Clock level

Sets the voltage level for the clock signal.

Remote command:

[TRIGger<m>:SPATtern:CSOurce:LEVel](#) on page 727

Data level

Sets the voltage level for the data signal.

If the signal value is higher than the data level, the state is 1. Below the level, the signal state is 0.

Remote command:

[TRIGger<m>:LEVel<n>\[:VALue\]](#) on page 704

Couple levels (Trigger level and hysteresis coupling)

Sets the trigger levels and hysteresis values for all channels to the values of the currently selected trigger source. The function affects only the levels defined for the selected event (A-, B-, or R-event). The hysteresis of the external trigger input is an independent value, and it is not affected by level coupling.

In trigger sequences, event coupling of trigger levels is possible: "[Couple levels of all events](#)" on page 170

Remote command:

[TRIGger<m>:SCOupling](#) on page 706

Pattern

The pattern contains the bits of the serial data to be found in the data stream. The maximum length of the pattern is 128 bit. Touch and hold the "Pattern" field to open the "Bit Pattern Editor" where you can enter the pattern in various formats.

See also: [chapter 14.1.4, "Bit Pattern Editor"](#), on page 425.

In binary format, an X indicates that the logical level for the bit is not relevant (don't care).

Remote command:

`TRIGger<m>:SPATtern:PATtern` on page 728

4.3.1.15 NFC Trigger

The Near Field Communication (NFC) trigger triggers on characteristic events of NFC signals. This trigger type requires option R&S RTO-K11 "I/Q Software Interface".

For details, see [chapter 16.4, "NFC Trigger"](#), on page 543

4.3.1.16 TV/Video Trigger

The TV or video trigger is used to analyze analog baseband video signals. You can trigger on baseband video signals from standard definition and high definition standards, and also on user defined signals.

The instrument triggers on the line start - the horizontal sync pulse. You can trigger on all lines, or specify a line number. You can also trigger on the field or frame start.

Additionally, a delay can be set: Set the "Holdoff events" in the "Sequence" tab to the number of fields to be skipped. See also: ["Holdoff mode"](#) on page 168.

Make sure that the trigger level crosses the synchronizing pulses of the video signal, see ["Trigger level"](#) on page 161.

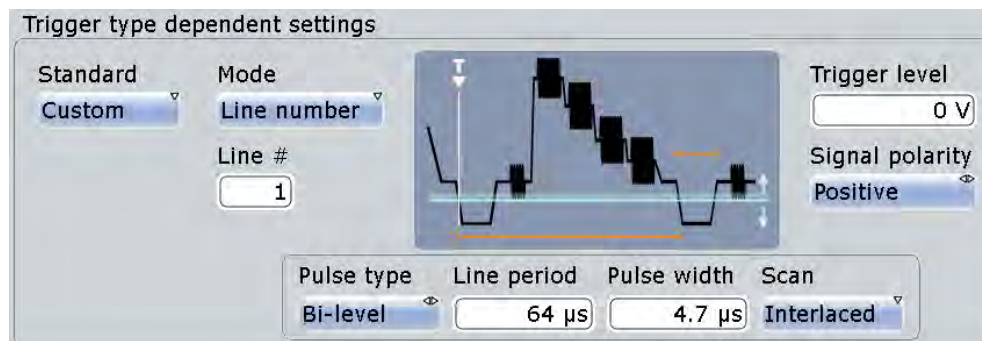

Most video signals have an output impedance of 75 Ω . The channel inputs of the R&S RTO have an input impedance of 50 Ω or 1 M Ω . Make sure to provide the adequate matching to ensure amplitude fidelity. A simple 75 Ω feed-through termination combined with 1 M Ω oscilloscope inputs is suitable for most applications.

Once the trigger is set correctly, you can use cursor and automatic measurements to perform amplitude and timing measurements.

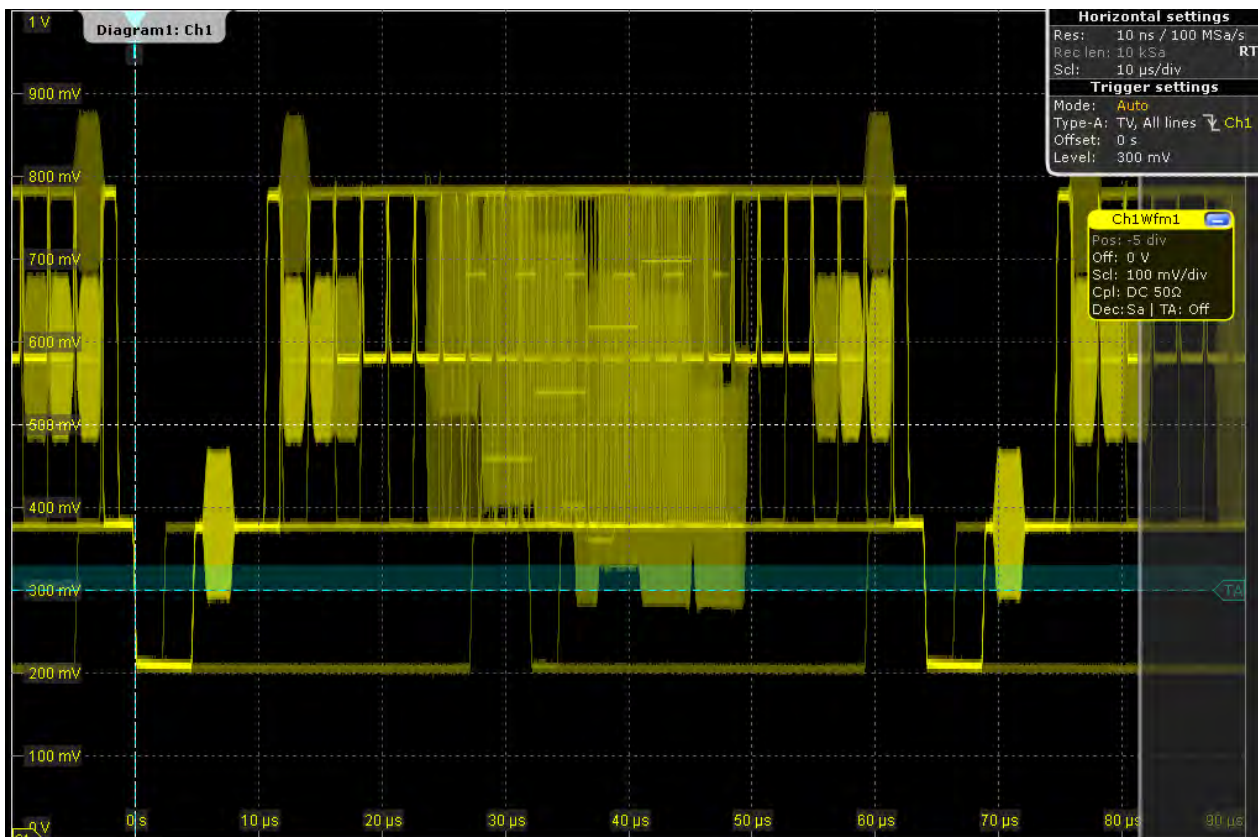

Fig. 4-4: Trigger on all lines of a PAL signal with positive signal polarity, trigger level = 300 mV

Standard

Selects the TV standard or "Custom" for user-defined signals.

HDTV standards are indicated by the number of active lines, the scanning system (p for progressive scanning, i for interlaced scanning) and the frame rate (or field rate for interlaced scanning).

1080p/24sF is a HDTV standard using progressive segmented frame scanning.

"Custom" can be used for signals of other video systems, for example, medical displays, video monitors, and security cameras. To trigger on these signals, you have to define the pulse type and length of the sync pulse, the scanning system and the line period.

Remote command:

[TRIGger<m>:TV:STANdard](#) on page 728

Mode

Selects the lines or fields on which the instrument triggers. Available modes depend on the scanning system.

"All fields" Triggers on the first video line of the frame (progressive scanning) or field (interlaced scanning), for example, to find amplitude differences between the fields.

- "Odd fields / Even fields" Triggers on the first video line of the odd or even field. The mode is available for interlaced scanning and progressive segmented frame scanning and can be used, for example, to analyze the components of a video signal.
- "All lines" Triggers on the line start of all video lines, for example, to find maximum video levels.
- "Line number" Triggers on a specified line. Enter the line number in "Line #".

Remote command:

[TRIGger<m>:TV:MODE](#) on page 729

Line

Sets the number of the line to be triggered on if "Mode" is set to "Line number". Usually the lines of the frame are counted, beginning from the frame start.

For NTSC signals, the lines are counted per field, not per frame. For these signals, you have to set the field (odd or even), and the line number in the field.

Remote command:

[TRIGger<m>:TV:LINE](#) on page 730

[TRIGger<m>:TV:LFIeld](#) on page 731

Trigger level

Sets the trigger level as threshold for the sync pulse. The hysteresis is set according to the settings in the "Noise Reject" tab.

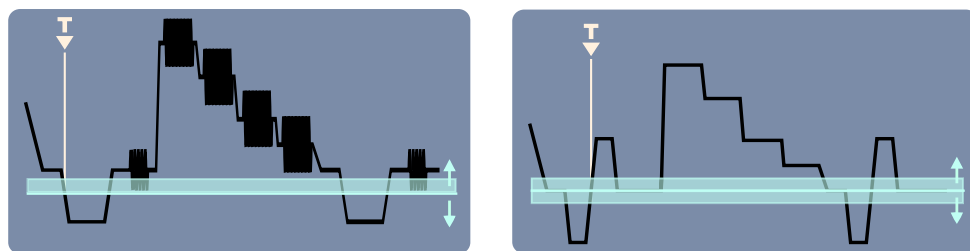

Remote command:

[TRIGger<m>:LEVel<n>\[:VALue\]](#) on page 704

Signal polarity

Sets the polarity of the signal. Note that the sync pulse has the opposite polarity, for example, a positive signal has a negative sync pulse.

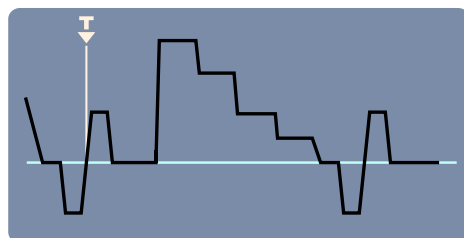

Fig. 4-5: Signal with positive polarity

Remote command:

[TRIGger<m>:TV:POLArity](#) on page 730

Pulse type

Sets the type of the sync pulse, either bi-level sync pulse (usually used in SDTV signals), or tri-level sync pulse (used in HDTV signals).

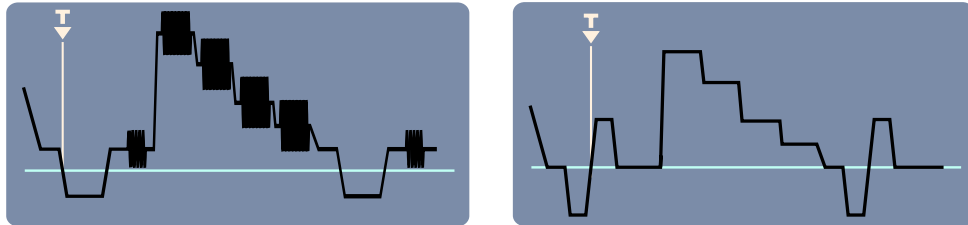

Fig. 4-6: Bi-level (left) and tri-level (right) sync pulses

This setting is available for user-defined video signals if "Standard" is set to "Custom".

Remote command:

[TRIGger<m>:TV:CUSTom:STYPe](#) on page 732

Line period

Sets the duration of a line, the time between two successive sync pulses.

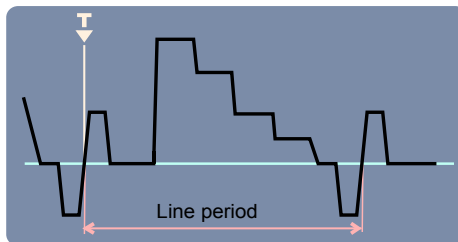

This setting is available for user-defined video signals if "Standard" is set to "Custom".

Remote command:

[TRIGger<m>:TV:CUSTom:LDURation](#) on page 732

Pulse width

Sets the width of the sync pulse.

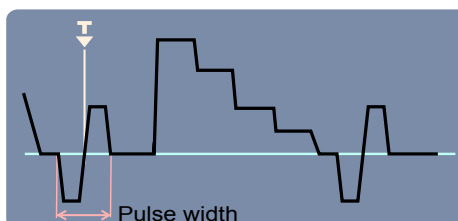

This setting is available for user-defined video signals if "Standard" is set to "Custom".

Remote command:

[TRIGger<m>:TV:CUSTom:SDURation](#) on page 733

Scan

Sets the scanning system.

This setting is available for user-defined video signals if "Standard" is set to "Custom".

"Interlaced"	Interlace scanning uses two fields to create a frame. One field contains all the odd lines (odd, first, or upper field), the other contains all the even lines of the image (even, second, or lower field). First the lines of the odd field are processed, then the lines of the even field.
"Progressive"	Progressive scanning is a method to capture, transmit and display all lines of a frame in sequence.
"Segmented"	Progressive segmented frame uses progressive scanning to capture the frame, and interlaced scanning for transmission and display.

Remote command:

[TRIGger<m>:TV:CUSTom:SCANmode](#) on page 732

4.3.1.17 CDR Trigger

The clock data recovery (CDR) trigger triggers on the edges of a clock edge stream that is recovered from a data signal using the hardware CDR. This trigger type requires option R&S RTO-K13 "CDR".

For details, see [chapter 17.2.2.2, "CDR Trigger"](#), on page 556.

4.3.1.18 Triggering on Serial Buses

Protocol analysis including configuration, triggering, and decoding is described in [chapter 14, "Protocol Analysis \(Base Functions and Options R&S RTO-K1 to K5\)"](#), on page 419

For information on triggering on serial buses, see:

- [chapter 14.2.3, "I²C Trigger"](#), on page 430
- [chapter 14.3.3, "SPI Trigger"](#), on page 444
- [chapter 14.4.3, "UART Trigger"](#), on page 452
- [chapter 14.6.3, "LIN Trigger"](#), on page 470
- [chapter 14.5.2, "CAN Trigger"](#), on page 459
- [chapter 14.7.2, "FlexRay Trigger"](#), on page 480

4.3.1.19 Triggering on Parallel Buses and Digital Channels

Triggering on digital signals requires the Mixed Signal Option (MSO, R&S RTO-B1). The option is described in [chapter 15, "Mixed Signal Option \(MSO, R&S RTO-B1\)"](#), on page 510.

For information on triggering, see [chapter 15.3.5, "Trigger Settings for Digital Signals and Parallel Buses"](#), on page 524.

4.3.2 Trigger Qualification

By qualifying a trigger event, you can logically combine the trigger signal with the state of other digital channel signals.

The instrument triggers if both of the following apply:

- The basic conditions of the trigger event definition are fulfilled.
- The logical conditions of the trigger qualification are true.

The A-event and B-event in a trigger sequence can have their own trigger qualification. Qualification is not supported with slew rate, Data2Clock, serial pattern, and TV trigger types.

- To enable the qualification settings, select [Qualify](#).

Example: Trigger on write access of a specific device of a bus system

In circuits using SPI, several slave devices use the same lines for reading and writing data, and each slave has its own select line. To trigger on write access of specific slave, the write line is the trigger source and the select line of the slave is set as qualifying condition.

Pattern

The pattern contains the channel selection, and the logical operations structure of hardware based boolean logic.

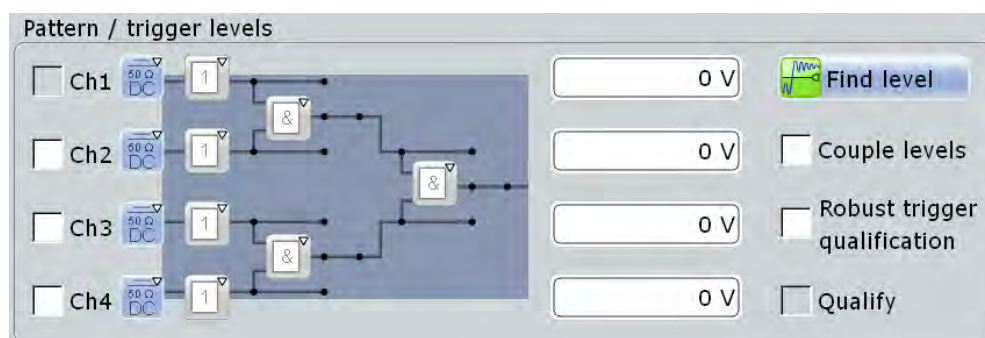

"Channel" Select the channels to be considered. For qualification, you can select all channel signals except for the trigger source. In Pattern trigger setup, the trigger source channel is selected by default, and you can select all other channel signals.

"Coupling" The current coupling or ground connection is shown for each channel and can be changed directly in the pattern, if necessary.

"Boolean operator" Defines the logical operation on the digital signal resulting from the comparison with the trigger level.

- "Direct": leaves the input value unchanged
- "NOT": inverts the input value

"Logical operator" defines the logic combination of two sources. The sources are channel 1/2 and channel 3/4 on the first step, and in the second step the logical combination resulting from the first step.

- $\&$ "AND": logical AND, conjunctive combination
- $\& \text{p}$ "NAND": logical NOT AND
- ≥ 1 "OR": logical OR, disjunctive combination
- $\geq 1 \text{p}$ "NOR": logical NOT OR

Remote command:

[TRIGger<m>:QUALify<n>:A:LOGic](#) on page 735

[TRIGger<m>:QUALify<n>:A\[:ENABle\]](#) on page 734

[TRIGger<m>:QUALify<n>:AB:LOGic](#) on page 736

[TRIGger<m>:QUALify<n>:ABCD:LOGic](#) on page 736

[TRIGger<m>:QUALify<n>:B:LOGic](#) on page 735

[TRIGger<m>:QUALify<n>:B\[:ENABle\]](#) on page 734

[TRIGger<m>:QUALify<n>:C:LOGic](#) on page 735

[TRIGger<m>:QUALify<n>:C\[:ENABle\]](#) on page 735

[TRIGger<m>:QUALify<n>:CD:LOGic](#) on page 736

[TRIGger<m>:QUALify<n>:D:LOGic](#) on page 735

[TRIGger<m>:QUALify<n>:D\[:ENABle\]](#) on page 735

[TRIGger<m>:QUALify<n>:STATe](#) on page 734

[TRIGger<m>:ECOupling](#) on page 706

Trigger Levels

Provides an overview of the current trigger levels of all input channels. For qualification and the pattern trigger, the trigger level is a decision threshold: If the signal value is higher than the trigger level, the signal state is high (1 or true for the boolean logic). Otherwise, the signal state is considered low (0 or false) if the signal value is below the trigger level.

Couple levels (Trigger level and hysteresis coupling)

Sets the trigger levels and hysteresis values for all channels to the values of the currently selected trigger source. The function affects only the levels defined for the selected event (A-, B-, or R-event). The hysteresis of the external trigger input is an independent value, and it is not affected by level coupling.

In trigger sequences, event coupling of trigger levels is possible: "[Couple levels of all events](#)" on page 170

Remote command:

[TRIGger<m>:SCOupling](#) on page 706

Robust trigger qualification

Activates the robust trigger for the qualification channels. Thus you can set the robust trigger separately for the trigger source and the qualification channels.

For details, see "[Robust trigger](#)" on page 141.

Qualify

Enables the settings for trigger qualification. As soon as a qualification pattern is defined, the option is selected by default.

4.3.3 Noise Reject

The rejection of noise by setting a hysteresis avoids unwanted trigger events caused by noise oscillation around the trigger level.

You can select the hysteresis mode and value for each channel separately, or couple the trigger levels and set the same hysteresis for channels. The hysteresis of the external trigger input is an independent value, and it is not affected by level coupling.

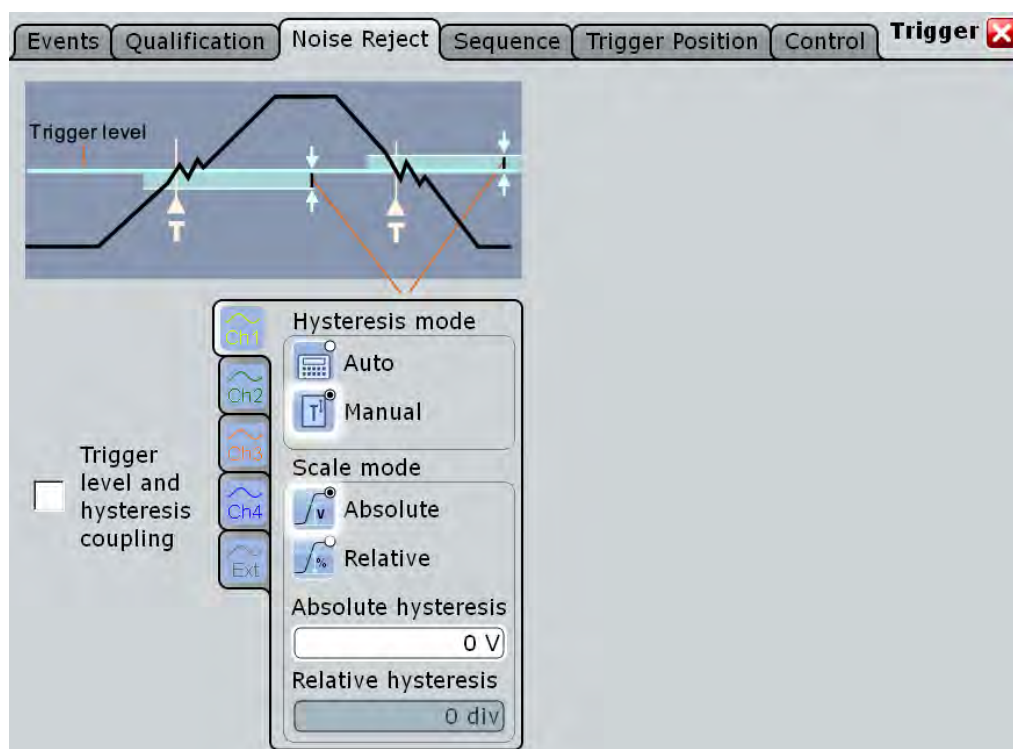

See also: ["Robust trigger"](#) on page 141

Hysteresis mode

Selects how the hysteresis is set.

"Auto" This is the recommended mode. The hysteresis is set by the instrument to reject the internal noise of the instrument.

"Manual" The hysteresis is defined directly in absolute or relative values.

Remote command:

[TRIGger<m>:LEvel<n>:NOISe\[:STATe\]](#) on page 736

Scale mode

Selects whether the hysteresis is defined in absolute or relative values. The setting is available only in manual hysteresis mode.

Remote command:

[TRIGger<m>:LEVel<n>:NOISe:MODE](#) on page 737

Absolute hysteresis

Defines a range in absolute values around the trigger level. If the signal jitters inside this range and crosses the trigger level thereby, no trigger event occurs.

Remote command:

[TRIGger<m>:LEVel<n>:NOISe:ABSolute](#) on page 737

Relative hysteresis

Defines a range in divisions around the trigger level. If the signal jitters inside this range and crosses the trigger level thereby, no trigger event occurs.

Remote command:

[TRIGger<m>:LEVel<n>:NOISe:RELative](#) on page 738

Couple levels (Trigger level and hysteresis coupling)

Sets the trigger levels and hysteresis values for all channels to the values of the currently selected trigger source. The function affects only the levels defined for the selected event (A-, B-, or R-event). The hysteresis of the external trigger input is an independent value, and it is not affected by level coupling.

In trigger sequences, event coupling of trigger levels is possible: "[Couple levels of all events](#)" on page 170

Remote command:

[TRIGger<m>:SCoupling](#) on page 706

4.3.4 Sequence

A trigger sequence consists of at least one trigger event and additional conditions defining when the trigger occurs.



The simple sequence "A only" contains an A-event and the holdoff setting as optional condition.



The complex trigger sequence "A → B → R" consists of two events - A and B - and an optional reset condition. After the A-event conditions have been met, the B-event with independent conditions is enabled. A- and B-events are configured in the same way. The only trigger type for the B-event is the edge trigger.

Without any reset, the instrument waits until one or a specified number of B-events occurs that causes the trigger, and then the sequence starts again. If you expect, for example, an irregular B-trigger event, you can configure a reset condition to restart the sequence. The reset condition can be a simple timeout, or a trigger event that is defined in the same way as the A- and B-trigger events. Most trigger types except for Data2Clock, pattern, serial pattern, NFC and TV can be used as reset event.

The complex trigger sequence "A → B → R" requires that input channels CH1...4 are set as trigger sources for all events. All other input sources are disabled. The "A → B → R" sequence is not available for NFC and TV trigger types.

The instrument checks the trigger settings for compatibility and disables settings that do not fit the previous settings in the sequence.

See also: [chapter 4.2.4, "Setting Up a Trigger Sequence"](#), on page 136.

SCPI command: `TRIGger<m>:SEquence:MODE` on page 739

4.3.4.1 A Only

The "A only" sequence contains an A-event and the holdoff setting as optional condition.

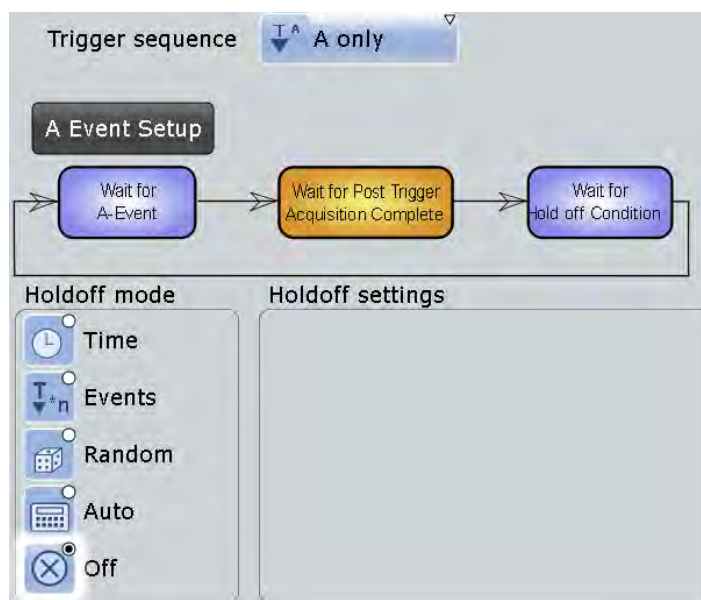

Holdoff mode

Selects the method to define the holdoff condition.



The trigger holdoff defines when the next trigger after the current will be recognized. Thus, it affects the next trigger to occur after the current one. Holdoff helps to obtain stable triggering when the oscilloscope is triggering on undesired events.



Holdoff settings are not available if the trigger source is an external trigger input or serial bus. For the TV trigger, only the "Events" mode is useful.



Example:

You want to analyze the first pulse in a burst of several pulses. At first, you select a sufficiently slow time base to display the entire burst. Then, you set the holdoff time a little longer than the length of the burst. Now, each trigger corresponds to the first pulse in successive bursts, and you can change the time base to display the waveform in more detail.



The following methods are available:

"Time"	Defines the holdoff directly as a time period. The next trigger occurs only after the "Holdoff time" has passed.
"Events"	Defines the holdoff as a number of trigger events. The next trigger only occurs when this number of events is reached. The number of triggers to be skipped is defined in "Holdoff events".
"Random"	Defines the holdoff as a random time limited by "Random minimum time" and "Random maximum time". For each acquisition cycle, the instrument selects a new random holdoff time from the specified range. Random holdoff prevents synchronization to discover effects invisible with synchronized triggering, for example, the features of a pulse train.
"Auto"	The holdoff time is calculated automatically based on the current horizontal scale. "Auto time scaling" defines the factor the horizontal scale is multiplied with. "Auto time" shows the resulting holdoff time: <i>Auto time = Auto time scaling * Horizontal scale</i> .
"Off"	No holdoff

Remote command:

[TRIGger<m>:HOLDoff:MODE](#) on page 741

[TRIGger<m>:HOLDoff:TIME](#) on page 741

[TRIGger<m>:HOLDoff:EVENTs](#) on page 742

[TRIGger<m>:HOLDoff:MAX](#) on page 743

[TRIGger<m>:HOLDoff:MIN](#) on page 742

[TRIGger<m>:HOLDoff:AUTotime?](#) on page 743

[TRIGger<m>:HOLDoff:SCALing](#) on page 744

4.3.4.2 A - B - R

The complex trigger sequence "A → B → R" consists of two trigger events - A and B - and an optional reset condition R.

See also: [chapter 4.2.4, "Setting Up a Trigger Sequence"](#), on page 136.

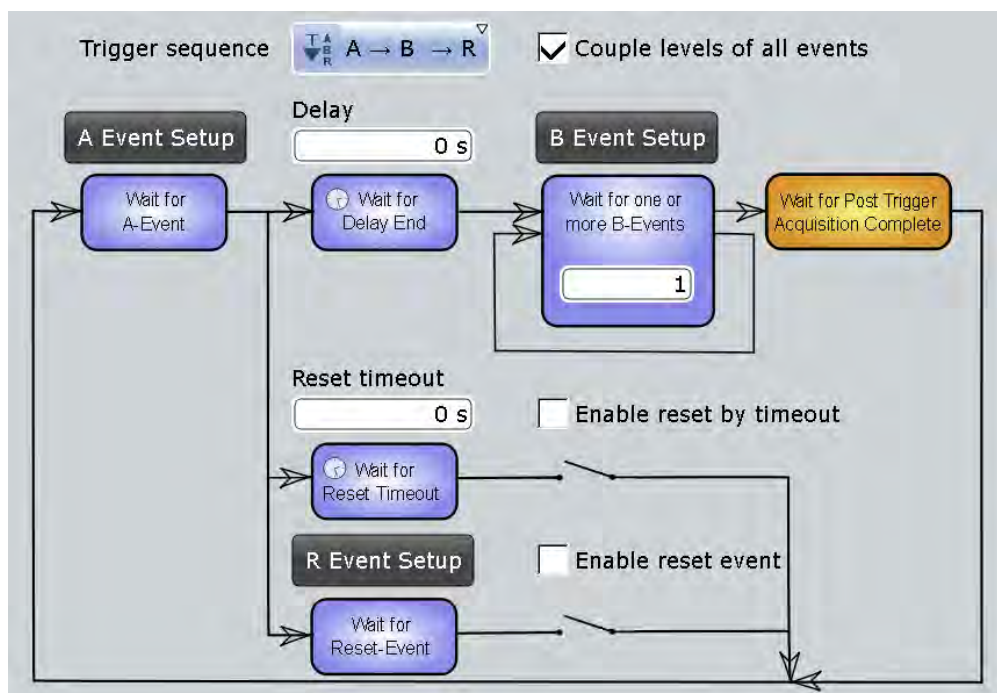

Couple levels of all events

Sets the channel trigger levels of the A-, B-, and R-event to the values of the current event (per channel).

Example:

If the "A Trigger" tab is selected in the "Events" tab, and the trigger level for Ch1 is 70 mV, the event coupling sets the trigger levels for Ch1 in the B- and R-events also to 70 mV.

Remote command:

[TRIGger<m>:ECOupling](#) on page 706

Delay

Sets the time the instrument waits after an A-event until it recognizes B-events.

Remote command:

[TRIGger<m>:SEquence:DELay](#) on page 739

Wait for one or more B-events

Sets the number of B-events to be fulfilled after an A-event. The last B-event causes the trigger. The waiting time for B-events can be restricted with a reset condition: timeout or reset event.

Remote command:

[TRIGger<m>:SEquence:COUNT](#) on page 739

Enable reset by timeout, Reset timeout

If enabled, the instrument waits for the specified time for the specified number of B-events. If no trigger occurs during that time, the sequence is restarted with the A-event.

Remote command:

`TRIGger<m>:SEquence:RESet:TIMEout[:ENABle]` on page 740

`TRIGger<m>:SEquence:RESet:TIMEout:TIME` on page 740

Enable reset event

If enabled, the trigger sequence is restarted by the R-event if the specified number of B-event does not occur before the R-event conditions are fulfilled.

Remote command:

`TRIGger<m>:SEquence:RESet:EVENT` on page 740

4.3.5 Horizontal Position

The horizontal position sets the location of the trigger in the waveform record and defines the visible section of the waveform. Thus you can see the pretrigger and post-trigger sections of the waveform. The pretrigger part can help troubleshooting, for example, to find the cause of a glitch. The posttrigger part shows what follows the trigger.

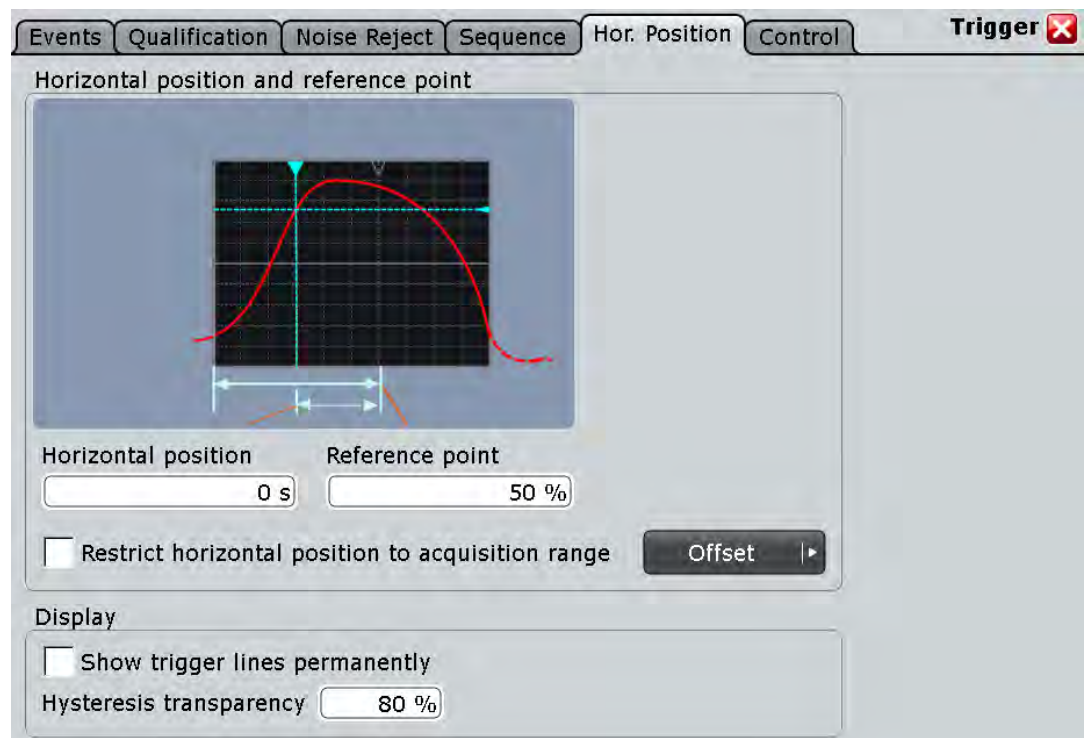

Events Qualification Noise Reject Sequence Hor. Position Control Trigger

Horizontal position and reference point

Horizontal position Reference point

Restrict horizontal position to acquisition range

Display

Show trigger lines permanently

Hysteresis transparency

Horizontal position

Defines the time distance between the reference point and the trigger point (the zero point of the diagram). If you want to see a section of the waveform some time before or after the trigger, enter this time as horizontal position. The requested waveform section is shown around the reference point. Use positive values to see waveform sections after the trigger - the waveform and the diagram origin move to the left.

See also:

- ["Reference point"](#) on page 107
- ["Waveform display"](#) on page 106

Remote command:

`TIMEbase:HORizontal:POSition` on page 677

Reference point

Sets the position of the reference point in % of the screen. The reference point marks the rescaling center of the time scale. It is indicated by a grey triangle outline at the top of the diagram. If you modify the time scale, the reference point remains fixed on the screen, and the scale is stretched or compressed to both sides of the reference point.

See also: ["Waveform display"](#) on page 106

Remote command:

`TIMEbase:REFerence` on page 678

Restrict horizontal position to acquisition range

If enabled, the horizontal position cannot be set outside the visible waveform diagram.

Show trigger lines permanently

Displays the trigger levels and the hysteresis in the diagrams until you disable this option.

Remote command:

`DISPlay:TRIGger:LINes` on page 702

Hysteresis transparency

Defines the transparency of the hysteresis area above or below the trigger level. The hysteresis is only visible if "Show trigger lines permanently" is enabled.

Trigger offset

Defines the time distance from the trigger point to the zero point of the diagram. If the trigger offset is 0, the trigger point matches the zero point. Positive values move the trigger to the right of the zero point.

This setting is more complex, it is recommended to use only "Horizontal position" to select the visible section of the waveform.

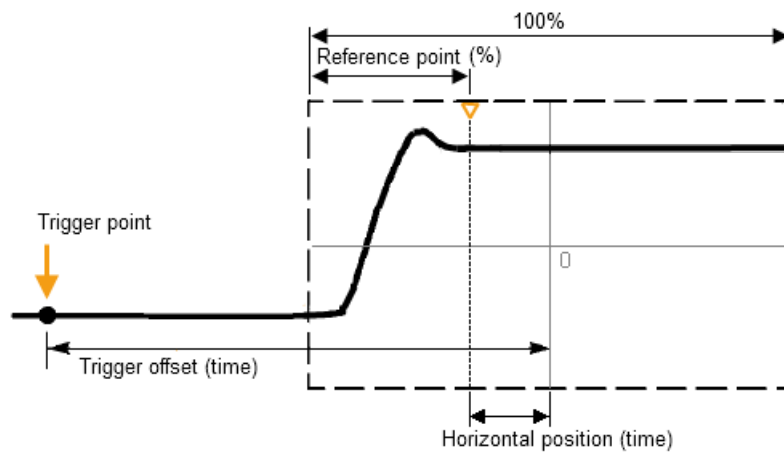

Remote command:

[TIMEbase\[:TRIGger\]:POSition](#) on page 745

4.3.6 Control

The settings and functions of trigger control define when the instrument triggers. They affect all kinds of trigger events and all triggers in a trigger sequence.

In addition to the settings in the dialog box, you need the RUN keys on the front panel to start and stop the triggering and thus the acquisition.

The R&S RTO can provide an external trigger signal to synchronize the measurements of other instruments. The trigger out signal is also adjusted and enabled in the "Control" tab.

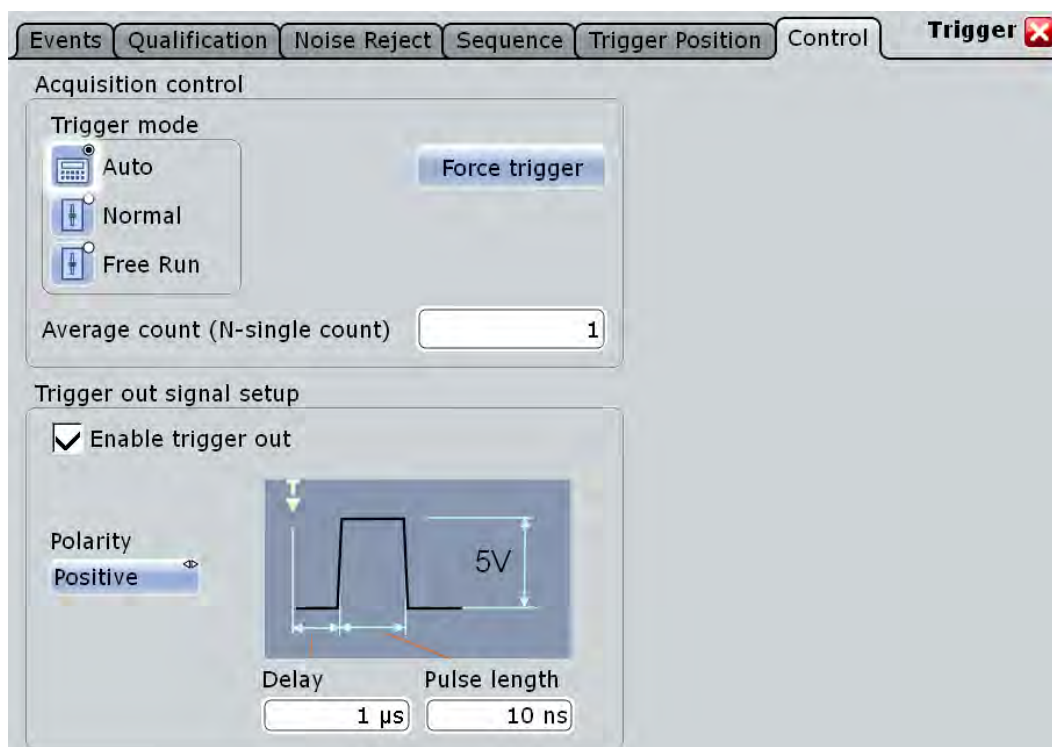

Trigger mode

Sets the trigger mode which determines the behavior of the instrument if no trigger occurs. The current setting is shown on the trigger label on top of the signal bar.



To toggle quickly between "Auto" and "Normal" mode, use the MODE key on the front panel (in "Trigger" section).

- "Auto" The instrument triggers repeatedly after a time interval if the trigger conditions are not fulfilled. If a real trigger occurs, it takes precedence. This mode helps to see the waveform even before the trigger conditions are set correctly. The waveform on the screen is not synchronized, and successive waveforms are not triggered at the same point of the waveform. The time interval depends on the time base settings.
- "Normal" The instrument acquires a waveform only if a trigger occurs, that is, if all trigger conditions are fulfilled. If no trigger occurs, no waveform is acquired and the last acquired waveform is displayed. If no waveform was captured before, none is displayed. When no trigger has been found for longer than one second, a message box appears that shows the time elapsed since the last trigger.
- "Free Run" The instrument starts acquisition immediately and triggers after a very short time interval independent of the time base settings and faster than in "Auto" mode. Real triggers are ignored. Use this mode if the "Auto" mode is too slow.

Remote command:

`TRIGger<m>:MODE` on page 745

Acquisition/average count

Access:

- TRIGGER > "Control" tab > "Average count (N-single count)"
- ACQUISITION > "Average count"
- HORIZONTAL > "Ultra Segmentation" tab > disable "Acquire maximum" > "Required"
- MATH > "Setup" tab > "Average count"

The acquisition and average count has several effects:

- It sets the number of waveforms acquired with RUN N× SINGLE.
- It defines the number of waveforms used to calculate the average waveform. Thus, the instrument acquires sufficient waveforms to calculate the correct average if "Average" is enabled for waveform arithmetic. The higher the value is, the better the noise is reduced.
- It sets the number of acquisitions to be acquired in an Ultra Segmentation acquisition series. Thus, you can acquire exactly one Ultra Segmentation acquisition series with RUN N× SINGLE.
If Ultra Segmentation is enabled and configured to acquire the maximum number of acquisitions, the acquisition count is set to that maximum number and cannot be changed. See also: "[Number of acquisitions](#)" on page 115.
- It is the "Finished" criteria for the state of a mask test.

Remote command:

[ACQUIRE:COUNT](#) on page 683

Force Trigger

If the acquisition is running in normal mode and no valid trigger occurs, forcing the trigger provokes an immediate single acquisition. Thus you can confirm that a signal is available and use the waveform display to determine how to trigger on it.

Remote command:

[TRIGGER<m>:FORCE](#) on page 746

RUN CONT. / RUN N× SINGLE

Front panel keys to start and stop a continuous acquisition or a defined number of acquisition cycles, respectively. The number of acquisitions is set with "Average count".

Remote command:

[RUN](#) on page 676

[SINGLE](#) on page 676

[STOP](#) on page 676

Trigger out signal setup

Defines the pulse that is provided to the EXT TRIGGER OUT connector on the rear panel.

A trigger out pulse can be provided either when a trigger occurs, or when a mask test violation occurs, or when a limit check violation in a measurement occurs.

"Enable trigger out"	Generates the trigger out signal on trigger event. The setting is not available if <ul style="list-style-type: none">• A mask test is running with "Trigger Out Pulse" set to "On violation".• A measurement running with limit check enabled and "Trigger Out Pulse" set to "On violation".
"Polarity"	Sets the polarity of the trigger out pulse, that is the direction of the first pulse edge.
"Pulse length"	Sets the length of the trigger out pulse.
"Delay"	Sets the delay of the first pulse edge to the trigger point. The setting is not available if "Enable trigger out" is not available.

Remote command:

[TRIGger<m>:OUT:STATe](#) on page 746

[TRIGger<m>:OUT:POLarity](#) on page 746

[TRIGger<m>:OUT:PLENgtH](#) on page 747

[TRIGger<m>:OUT:DELay](#) on page 747

5 Display

• Display Customization.....	177
• Zoom.....	193
• XY-diagram.....	204
• History.....	207

5.1 Display Customization

5.1.1 Display Settings

You can customize the various elements on the screen according to your needs:

Signal bar

The signal bar contains signal icons (mini windows) that display either real-time views of minimized waveforms, or labels with setting information for displayed waveforms. In addition, the timebase label and trigger label provide general information for all displayed channels.

The signal bar can be manually switched on and off, it can be automatically hidden, and you can adjust color and transparency of the bar. In addition, you can define the signal behavior when tapping a signal icon.

Toolbar

The toolbar contains icons that start frequently used functions. You can define which tools are displayed on the toolbar.

Diagrams

The basic diagram elements can be shown or hidden: grid, crosshair, label, and tab titles. You can also enter user-defined diagram names.

Waveforms

For waveforms, you can adjust the persistence, the waveform style, and color. You can also annotate the waveforms by adding screen texts.

To set the color, you can select it from a color palette or assign color tables defining the color of waveform pixels depending on the cumulative occurrence of the associated values. For each waveform you can assign a different color table.

The following default color tables are provided:

- "Temperature": shade of color changes gradually from blue (low temperature) to red (high temperature) with increasing cumulative occurrence.
- "False colors": color changes gradually in a wide color spectrum with increasing cumulative occurrence.

- Spectrum: colors used to display the wave lengths of the light are assigned to the cumulative occurrence. High cumulative occurrence is displayed blue like high wave length.
- Single event: single events and very seldom events appear yellow, a higher cumulative occurrence is shown with blue color. This view helps to identify specific events.

Dialog boxes and result boxes

You can configure the font size, contrast and transparency in dialog and result boxes. Thus, you can optimize readability or keep track of the waveforms while changing settings in dialog boxes.

Clear screen results

To delete all results and waveforms, select "Display" menu > "Clear screen results".

5.1.2 Adjusting the Display

To change the diagram name

- ▶ Double-tap the diagram tab name. The on-screen keyboard opens to enter the new name.

5.1.2.1 Editing Waveform Colors

For each waveform, you can set a waveform color, or you define a color table that specifies which waveform points are displayed in which color. You can use one of the default color tables, or define your own table according to your needs. You can also edit the default color tables.

After you define a color table, you must assign it to the waveform it is to be used for, and enable its use.



The exact mapping of the cumulative value occurrences according to the assigned color table is guaranteed only if the intensity is set to 50%. All other intensity values falsify the mapping but may improve the visibility of the signal.

See also: "[Intensity](#)" on page 184.

For details on signal color settings, see [chapter 5.1.3.2, "Color Tables"](#), on page 185.

To change a waveform color

1. On the "Display" menu, tap "Signal Colors / Persistence".
2. Under "Color table assignment", select the tab of the waveform for which the color is to be changed.
3. Tap the "Color" button.

- In the "Adjust Colors" dialog box, select a predefined color, or define any other RGB color with "Userdefined Colors".

To edit a color table

- On the "Display" menu, tap "Color Tables".
- Under "Edit Color Tables", select the color table you want to edit.

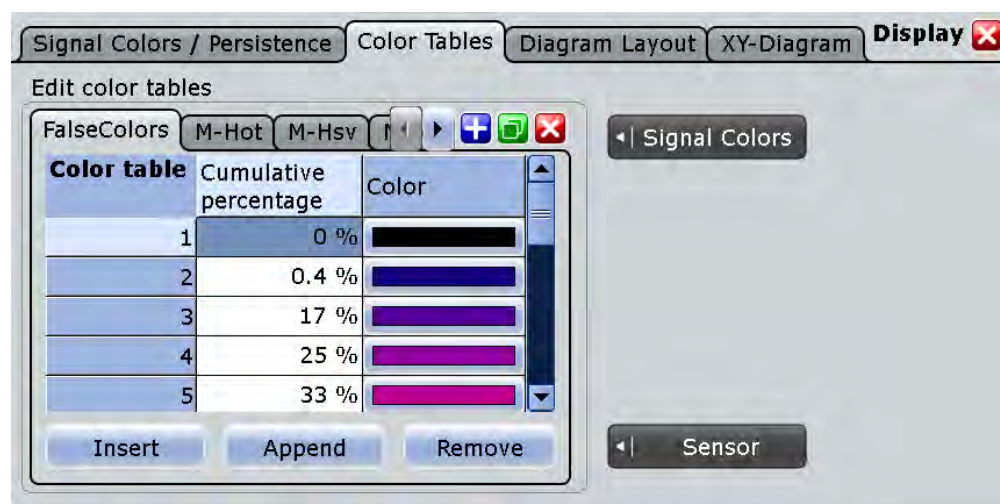

- For each range of cumulative occurrence of the values, insert an entry in the color table:
 - To insert an entry at the end of the color table, tap "Append".
 - To insert an entry before an existing entry, tap the existing row and tap "Insert".
 - To remove an entry, tap the entry, then tap "Remove".
- Assign a color to each entry: Tap the "Color" cell and select a predefined color, or define your own color.

Example:

Color table	Cumulative percentage	Color
1	25 %	Green
2	50 %	Yellow-green
3	100 %	Red

In this example, values with a cumulative occurrence under 25% (very short or rare display) are displayed green, whereas values with an occurrence of 40% are yellow-green, and values with an occurrence of 90% (displayed almost for the entire duration of the signal) are a deep shade of orange.

To create a new color table

- On the "Display" menu, tap "Signal Colors".

2. **To create an empty color table:** tap the "Add" button and enter a name for the new color table using the on-screen keyboard.
To copy an existing color table: select the color table you want to copy, and tap the "Copy" button. Enter a name for the new color table using the on-screen keyboard.

To assign the color table and enable its use

1. Open the "Signal Colors/ Persistence" tab of the "Display" dialog box.
2. Under "Color Table Assignment", select the tab for the waveform.
3. Enable "Use Color table".

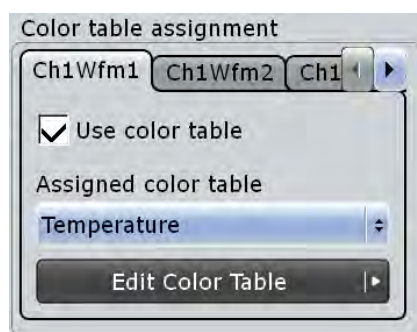

4. Under "Assign color table", select the color table you want to assign to the waveform.

The waveform colors are displayed according to the definition in the color table.

5.1.2.2 Using the Signal bar

The signal bar can hold a large number of signal and result icons. Signal icons represent the waveforms, serial buses and parallel buses, while result icons are minimized result boxes showing measurement and search results.

To scroll the signal bar

If the signal bar contains more than five icons, not all icons are visible on the display.

- ▶ Touch one of the icons and move it up or down until the required icon appears.

To switch on and off the signal bar

If you need the complete screen to see the diagrams and results, you can switch off the signal bar completely.

- ▶ Tap the "Show Signal Bar" icon on the toolbar.



Alternatively, tap "Signal Bar" on the "Display" menu.

To change the position of the signal bar

- ▶ Touch the horizontal and trigger label on the top and drag the signal bar to the opposite side of the screen.

To set the action on tapping the signal icon

You can define what happens when you tap a signal icon: Either the waveform is minimized, or selected (get the focus).

1. Press the DISPLAY key on the front panel.
2. In the "Display" dialog box, select the "Diagram Layout" tab.
3. Under "Signal bar", tap "Click on signal icon".
4. Select the action on clicking/tapping:
 - "Minimize": The waveform switches from the diagram to the signal icon and is shown as small real-time preview.
 - "Hardkey logic": Selects the waveform for further operation.

To configure auto-hide

The signal bar can be hidden if the displayed information has not changed for a defined time, and is displayed again automatically when a setting in the signal bar changes. The signal bar is not hidden entirely, it simply fades and becomes less visible in the display.

1. Press the DISPLAY key on the front panel.
2. In the "Display" dialog box, select the "Diagram Layout" tab.
3. Select "Auto-hide".
4. Define the hiding properties:
 - "Hide bar after": the time after which the bar is hidden if no changes occur
 - "Hiding opacity": Opacity of the hidden signal bar on a scale from 30% (high transparency) to 80% (lower transparency and better visibility)
 - Hide head also: the horizontal and trigger labels are also faded

To change the colors

If you want to highlight the signal bar, you can change the "Fill color" and "Border color" of the bar.

1. Press the DISPLAY key on the front panel.
2. In the "Display" dialog box, select the "Diagram Layout" tab.
3. Tap "Border color" to change the color of the signal bar frame, or "Fill color" to change the fill color of the bar.
4. In the "Adjust Colors" dialog box, select the color to be used.

5. To use a color that is not yet defined, tap "Userdefined Colors" and define the new color settings. To see the effect of a setting change in the Preview area, enter the value and press the ENTER key.
6. Tap "OK."
The signal bar is displayed in the new colors.

5.1.2.3 Configuring Dialog and Result Boxes

You can optimize the display of dialog and result boxes so they do not interfere with the waveform display and you can still analyze the results and settings.

To change the font size in dialogs

1. Press SETUP.
2. In the "Screen" tab, enter the desired font size in points for all dialog box texts.
Most dialog boxes are optimized for a font size of 19 pt.

To change the transparency of dialog boxes and result boxes

The transparency of the dialog box background lets you see the waveforms behind the box. You can configure the transparency separately for dialog boxes and result boxes.

1. Press SETUP.
2. In the "Screen" tab, in the "Dialog box transparency" field, enter the transparency value for dialog boxes.
For high transparency values, you can see the waveform display in the background, and possibly check the effect of the changed setting. For lower transparency values, readability in the dialog box improves.
3. In the "Result box transparency" field, enter the transparency value for result boxes.



Alternatively, you can press the INTENSITY knob until the required parameter is shown in the data input box, and then turn the knob to set the transparency.

To change the color theme and contrast for dialog boxes

When you print a screenshot of the display, it is helpful to use dark-colored text on a light-colored background. For improved readability, different settings are required, depending on the transparency value.

1. Press SETUP.
2. In the "Screen" tab, select the color theme suitable for the current operating situation.

5.1.2.4 Configuring the Toolbar

You can configure which icons are visible on the toolbar and which are hidden, so that only the ones you use are displayed. Furthermore, you can define whether the current date and time are displayed on the toolbar.

1. On the "Display" menu, select "Toolbar".
2. For each icon you want to use, select the "Visible" option.
To display all available icons, tap "Show All".
To hide all available icons, tap "Hide All".
3. Enable the "Show date and time" option to display the current date and time on the toolbar.

5.1.3 Reference for Display Settings

Display settings are configured in the "Display" dialog box, which is opened when you press the DISPLAY key or select an item from the "Display" menu.

5.1.3.1 Signal Colors / Persistence

The "Signal Colors / Persistence" tab contains settings for the general display of waveform data.

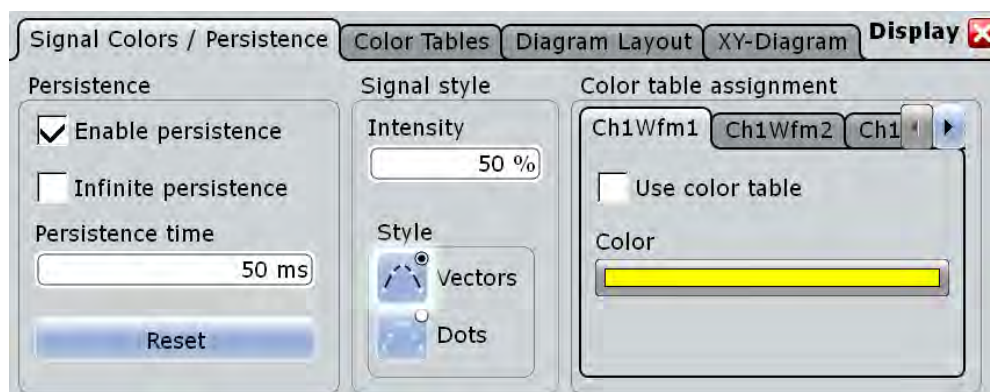

Enable persistence

If enabled, each new data point in the diagram area remains on the screen for the duration defined under [Persistence time](#), or as long as [Infinite persistence](#) is selected. If disabled, the signal value is only displayed as long as it actually occurs.

Remote command:

[DISPlay:PERsistence\[:STATe\]](#) on page 748

Infinite persistence

If persistence is enabled, each new data point in the diagram area remains on the screen infinitely until this option is disabled.

Remote command:

`DISPlay:PERsistence:INFinite` on page 748

Persistence time

If persistence is enabled, each new data point in the diagram area remains on the screen for the duration defined here.

Remote command:

`DISPlay:PERsistence:TIME` on page 748

Reset

Resets the display, removing persistent values.

Remote command:

`DISPlay:PERsistence:RESet` on page 748

Intensity

This value determines the strength of the waveform line in the diagram. Enter a percentage between 0 (not visible) and 100% (very strong). The default value is 50%.

You can also use the INTENSITY knob on the left side of the screen to adjust the waveform intensity directly.

Note: Use of color tables. The exact mapping of the cumulative value occurrences according to the assigned color table is guaranteed only if the intensity is set to 50%. All other intensity values falsify the mapping but may improve the visibility of the signal. See also: [chapter 5.1.2.1, "Editing Waveform Colors"](#), on page 178.

Remote command:

`DISPlay:INTensity` on page 748

**Style**

Select the style in which the waveform is displayed:



"Vectors"

The individual waveform points are connected by a line. Define the strength of the line using the INTENSITY knob on the left side of the screen.

"Dots"

Only the individual waveform points are displayed. Waveform sample points are the ADC sample points and additional interpolated points if "Interpolated time" is used for resolution enhancement. To see the dots of one waveform, perform one acquisition with RUN N× SINGLE and N=1 ("Average count" = 1). During continuous acquisition, or a RUN N× SINGLE acquisition with N > 1, the dots of multiple subsequent waveforms are displayed on the screen, and the waveform on the screen might look like a line.

Consider also the ["Interpolation mode"](#) on page 111.

Remote command:

`DISPlay:DIAGram:STYL`e on page 749

Color

Shows the current color of the selected waveform. To change the color, tap the button and select a color. The color of the waveform, of its signal icon and of the illuminated keys is adjusted to the new color.

Use color table

If enabled, the selected waveform is displayed according to its assigned color table.

If this option is disabled, the default color is displayed, and the intensity of the specific signal color varies according to the cumulative occurrence of the values.

Remote command:

[DISPlay:COLor:SIGNal<m>:USE](#) on page 749

Assigned color table

Adjust the waveform colors to suit your preferences. For each of the following waveform types you can assign a suitable color table:

- each waveform of any channel
- a reference waveform
- the results of a mathematical function
- a stored measurement
- an xy-diagram

The following default color tables are provided:

- "Temperature": shade of color changes gradually from blue (low temperature) to red (high temperature) with increasing cumulative occurrence.
- "False colors": color changes gradually in a wide color spectrum with increasing cumulative occurrence.
- Spectrum: colors used to display the wave lengths of the light are assigned to the cumulative occurrence. High cumulative occurrence is displayed blue like high wave length.
- Single event: single events and very seldom events appear yellow, a higher cumulative occurrence is shown with blue color. This view helps to indentify specific events.

Remote command:

[DISPlay:COLor:SIGNal<m>:ASSign](#) on page 749

5.1.3.2 Color Tables

Color tables define the color of the waveform pixels depending on the cumulative occurrence of the associated values. By default, the intensity of the specific waveform color varies according to the cumulative occurrence of the values, i.e. the more often a value occurs, the darker the color of the data point is displayed.

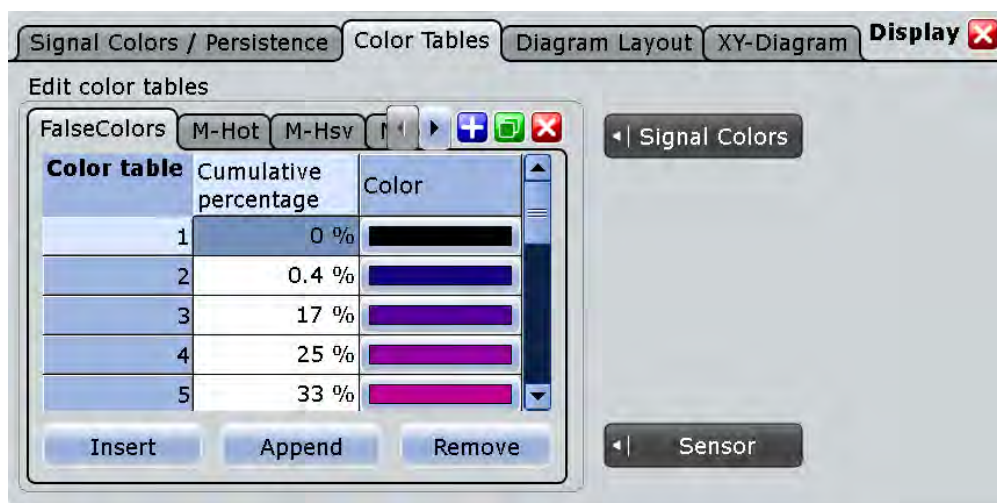

The following default color tables are provided:

- Temperature
- False colors
- Spectrum
- Single event
- M-Hot
- M-Hsv
- M-Jet

The editing table allows you to edit existing color tables or add new ones that can then be assigned to the waveforms. To assign a color table to a waveform, use the "Signal colors / Persistence" tab.

See also:

- [chapter 5.1.2.1, "Editing Waveform Colors"](#), on page 178
- [Assigned color table](#)

Remote commands

The following remote commands are used to configure color tables:

[DISPlay:COLor:PALette:COUNT?](#) on page 750

[DISPlay:COLor:PALette:ADD](#) on page 750

[DISPlay:COLor:PALette:REMove](#) on page 750

[DISPlay:COLor:PALette:POINT:INSert](#) on page 750

[DISPlay:COLor:PALette:POINT:ADD](#) on page 750

[DISPlay:COLor:PALette:POINT\[:VALue\]](#) on page 751

[DISPlay:COLor:PALette:POINT:COUNT?](#) on page 751

[DISPlay:COLor:PALette:POINT:REMove](#) on page 751

[DISPlay:COLor:PALETTE:COUNT?](#) on page 750

5.1.3.3 Diagram Layout

On the "Diagram Layout" tab, you define the basic diagram layout and the appearance and behavior of the signal bar.

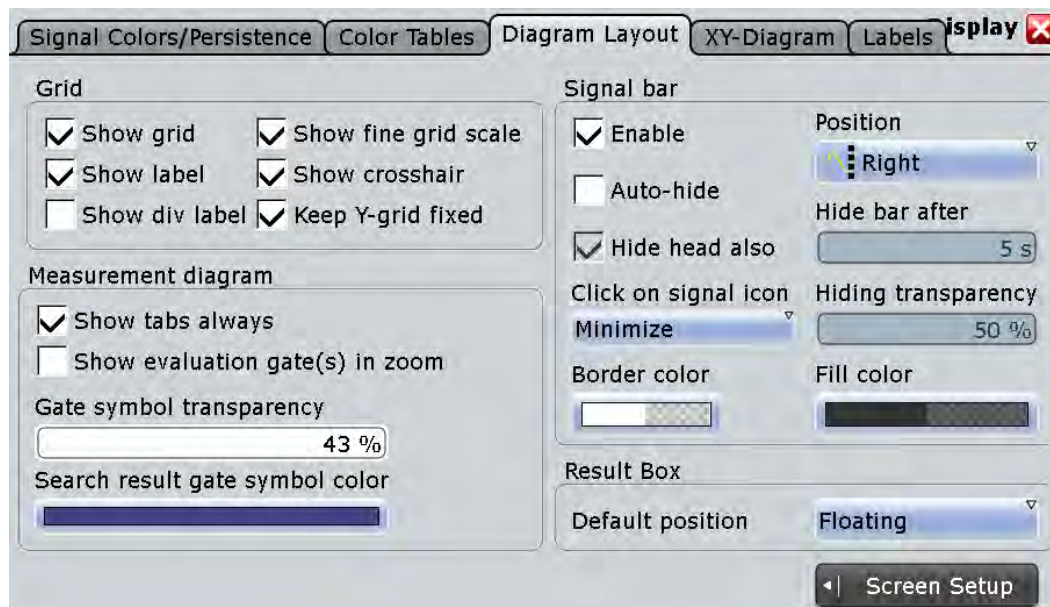

Show grid

If selected, a grid is displayed in the diagram area. A grid helps you associate a specific data point to its exact value on the x- or y-axis.

Remote command:

[DISPlay:DIAGram:GRID](#) on page 752

Show label

If selected, labels mark values on the x- and y-axes in specified intervals in the diagram.

Remote command:

[DISPlay:DIAGram:LABels](#) on page 753

Show div label

If selected, the time scale value is shown at the diagram bottom instead of the horizontal grid labels. For example, 10 ns/div is shown instead of the values 0, 10, 20, 30... ns.

Show fine grid scale

If selected, the crosshair is displayed as a ruler with scale markers. If disabled, the crosshair is shown as dashed lines.

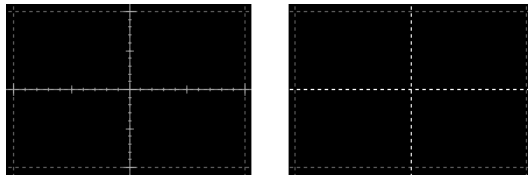

Remote command:

[DISPlay:DIAGram:FINegrid](#) on page 752

Show crosshair

If selected, a crosshair is displayed in the diagram area. A crosshair allows you to select a specific data point by its co-ordinates.

Remote command:

[DISPlay:DIAGram:CROShair](#) on page 752

Keep Y-grid fixed

If enabled, the horizontal grid lines remain in their position when the position of the curve is changed. Only the values at the grid lines are adapted. This reflects the behavior of traditional oscilloscopes.

Remote command:

[DISPlay:DIAGram:YFIXed](#) on page 753

Show tabs always

If selected, the tab titles of all diagrams are displayed: "Diagram1", "Diagram2" ...

If cleared, the tab titles are not shown except for those in a tabbed diagram. In tabbed diagrams, the tab titles are required to change the tabs.

Remote command:

[DISPlay:DIAGram:TITLe](#) on page 753

Show evaluation gate(s) in zoom

If enabled, the available histogram areas, masks, and measurement gates are shown in the zoom diagrams. If the evaluation gate is within the zoom area, the display helps to move or modify the evaluation gates in the zoom window.

Make sure that the option is disabled if the zoom area and the evaluation gate are of nearly the same size to avoid conflicts in mouse operation.

Gate symbol transparency

Sets the transparency of the area that is defined as measurement or search gate. The setting only takes effect if "Show gate" is enabled.

Search result gate symbol color

Sets the color of the search zoom area. The search zoom area is displayed if "Show search zoom windows" is enabled. See also: "[Search zoom window](#)" on page 356.

Enable (Signal bar)

If enabled, the signal bar is displayed in the diagram area.

The signal bar contains signal icons (mini windows) that display either real-time views of minimized waveforms, or labels with setting information for displayed waveforms. In addition, the timebase label and trigger label provide general information for all displayed channels.

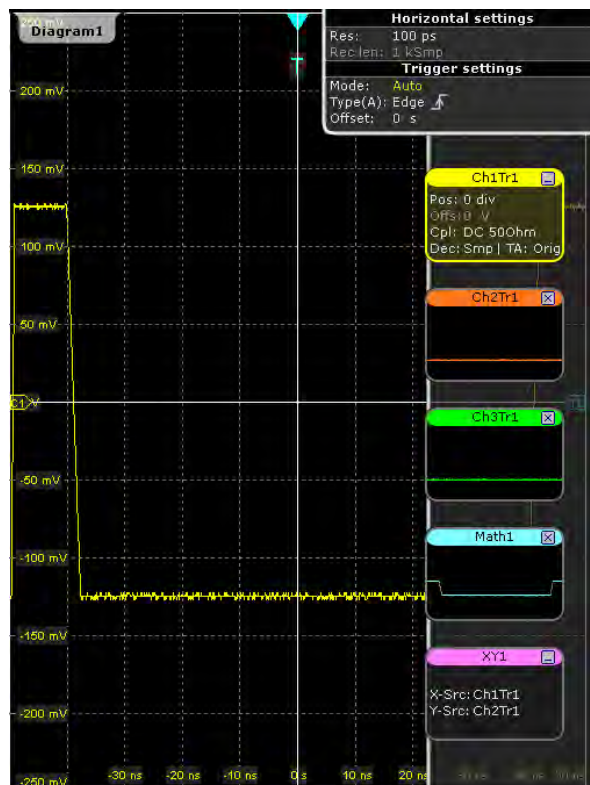

Remote command:

[DISPlay:SIGBar\[:STATe\]](#) on page 753

Position

The signal bar can be placed vertically at the right (default position), or at the left to ensure best visibility of the waveforms.

Remote command:

[DISPlay:SIGBar:POSition](#) on page 753

Auto-hide

If selected, the signal bar disappears automatically after some time, similar to the Windows task bar. With the settings below "Auto hide", you can define when and how the signal bar hides.

The signal bar reappears if you tap it, or if an action changes the content of the bar.

Remote command:

[DISPlay:SIGBar:HIDE\[:AUTO\]](#) on page 754

Hide bar after

Sets the time when the signal bar is faded out with "Auto-hide".

Remote command:

[DISPlay:SIGBar:HIDE:TIME](#) on page 754

Hide head also

If selected, the "Auto hide" function hides also the horizontal and trigger label at the top of the signal bar.

Remote command:

[DISPlay:SIGBar:HIDE:HEAD](#) on page 754

Hiding transparency

Sets the transparency of the signal bar when the signal bar is faded out with "Auto-hide". The maximum value is 70% applies the least visibility of the signal bar. At the minimum value 20% the signal bar is always slightly visible.

Remote command:

[DISPlay:SIGBar:HIDE:TRANsparency](#) on page 754

Click on signal icon

Defines what happens when you tap or click a signal icon.

- | | |
|-----------------|--|
| "Minimize" | The waveform is minimized, it switches from the diagram to the signal icon and is shown as small real-time preview. This behavior is well-known to R&S RTO users. |
| "Hardkey logic" | The waveform is selected and gets the focus. This behavior is introduced with firmware version 1.50 and has the same effect as pressing the corresponding channel key. |

Border color

Opens a color selection dialog box to define the color of the signal bar border.

For details, see ["To change the colors"](#) on page 82.

Remote command:

[DISPlay:SIGBar:COLor:BORDer](#) on page 754

Fill color

Opens a color selection dialog box to define the fill color of the signal bar.

For details see ["To change the colors"](#) on page 82.

Remote command:

[DISPlay:SIGBar:COLor:FILL](#) on page 755

Default position (Result box)

Defines where a new result box opens.

- | | |
|------------|--|
| "Floating" | The result box opens as a box similar to a dialog box in front of the diagrams. It can be moved and shows all results. |
|------------|--|

"Preview" The result box opens as a minimized result icon on the signal bar. It shows only two columns and a few rows of the results.

Remote command:

[DISPlay:RESultboxes:DEFaultpos](#) on page 755

5.1.3.4 Waveform Labels

Access: DISPLAY > "Labels" tab

Using labels, you can annotate the waveforms to name or explain each waveform. The text is shown in the same color as the assigned waveform. Each label has its individual position. You can enter exact positions in the dialog box, or drag the labels on the screen to the required position. The position can be a fixed one (relative to the screen), or a flexible position (absolute, assigned to the axes).

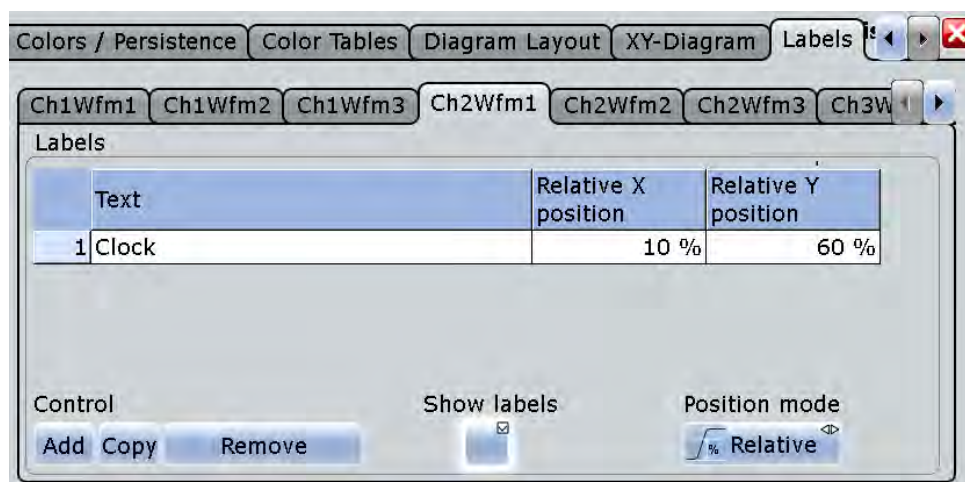

Make sure that the correct waveform tab is selected before you enter the labels.

Labels

For each waveform, the "Labels" table shows the assigned texts and their positions. Enter the label text and the horizontal and vertical positions for each label.

"Add" Adds a new line at the end of the list.

"Copy" Copies the selected line in a new line.

"Remove" Deletes the selected line.

You can also delete a label by using the toolbar: Tap the "Delete" icon and then the label.

Remote command:

[DISPlay:SIGNal:LABel:ADD](#) on page 758

[DISPlay:SIGNal:LABel:REMOve](#) on page 759

[DISPlay:SIGNal:LABel:TEXT](#) on page 759

[DISPlay:SIGNal:LABel:HORIZontal:ABSolute:POSition](#) on page 760

[DISPlay:SIGNal:LABel:VERTical:ABSolute:POSition](#) on page 760

[DISPlay:SIGNal:LABel:HORIZontal:RELative:POSition](#) on page 761

[DISPlay:SIGNal:LABel:VERTical:RELative:POSition](#) on page 761

Show labels

Enables or disables the label display.

Position mode

Defines the label position either relative to the diagram or with absolute values according to the units of the waveform. Relative positions are fixed, whereas absolute positions move with the waveform display when the scales, the vertical position or offset, or the reference point are changed.

The position mode applies to all labels of the selected waveform. For different waveforms, different position modes can be selected.

"Relative" Sets a fixed position in percent of the screen counting from the upper left corner.

"Absolute" Sets the position in time and voltage values, or in other units depending on the waveform character.

Remote command:

[DISPlay:SIGNal:LABel:POSMoDe](#) on page 759

5.1.3.5 Toolbar

The "Toolbar" dialog box is displayed when you select "Toolbar" in the "Display" menu. Here you can configure the contents of the toolbar.

**Tool Settings**

Defines the visibility of selected toolbar icons.

Show All

Displays all available toolbar icons.

Hide All

Hides all toolbar icons.

Show date/time

Displays the current date and time on the toolbar.

5.1.3.6 Performance

Information on the current acquisition performance values of the R&S RTO is available by selecting the "Display > Performance" menu entry.



Performance	
Acquisition per frame	30610
Acquisition per second	1020000
Time per frame	0.03

The instrument groups acquired waveforms together in a frame, and displays the frame content. The maximum number of frames displayed per second is about 30. The current number of frames per second is indicated as reciprocal "Time per frame". If the time scale decreases, and thus the number of acquisitions per second also decreases, the number of acquisitions per frame can drop to 1.

5.1.3.7 Clear Screen Results

The function "Clear screen results" in the "Display" menu resets all results in all measurement result boxes including long term measurement and statistic results and deletes the current measurement waveforms.

5.2 Zoom

The zoom functions allow you to magnify a specific section of the diagram in order to view more details. You can define several zoom areas for the same diagram and even couple them, or you use the hardware zoom.

5.2.1 Methods of Zooming

The R&S RTO provides the usual way of zooming: You define the section of a diagram that you want to magnify, and the zoomed view is shown in a separate zoom diagram. Additionally, you can magnify the diagram directly: The hardware zoom changes the horizontal and vertical scales of the diagram so that you see the selected section.

There are different ways to initiate and configure the zoom function:

- **Graphically** by drawing and moving the zoom area on the touchscreen – a very quick and simple method for hardware zoom and zoom diagrams
- **Numerically** by entering x- and y-values in a dialog box – a more precise method which can be used to optimize a graphically defined zoom

With the numeric method there are two ways of defining the zoom area:

- Specifying **start and stop values** for the x- and y-axes; the acquired data within those values is zoomed.

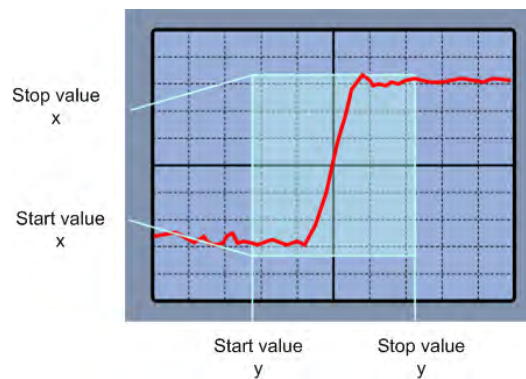

Fig. 5-1: Numeric zoom using start and stop values

- Specifying the x- and y-**position** of the centerpoint of the area plus a **range** for the x- and y-axes; the area defined by that centerpoint and the ranges is zoomed.

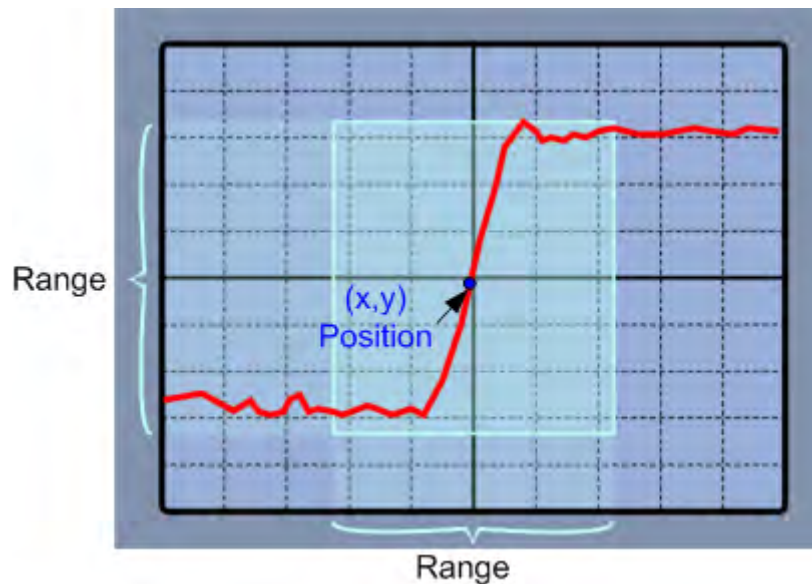

Fig. 5-2: Numeric zoom using position and range

- **Coupled zoom** creates a copy of the selected zoom area. Coupled zoom areas always have the same size (size coupling). They can be positioned separately or together (position coupling)



Evaluation gates - available histogram areas, masks, and measurement gates - can be displayed in zoom diagrams to simplify the graphical gate adjustment on the touch-screen. See: "[Show evaluation gate\(s\) in zoom](#)" on page 188.

5.2.2 Zooming for Details

Use one of the following zooming methods:

- [To define the zoom area graphically](#)

- To define the zoom area numerically using start-stop values
- To define the zoom area numerically using position and range values
- To define multiple zoom areas
- To define coupled zoom areas
- To close the zoom diagram
- To use the hardware zoom

To define the zoom area graphically

For graphical zooming, you use your finger on the screen, or the navigation knob.

1. On the toolbar, tap the "Zoom" icon.



2. In the active signal you want to zoom into, touch the position in the diagram that you want to define as one corner of the zoom area, then drag your finger to the opposite corner of the zoom area.

While you drag your finger on the touch screen, a dotted rectangle is displayed to indicate the current zoom area. When the rectangle covers the required zoom area, remove your finger.

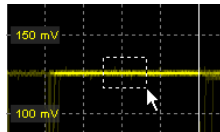

The indicated area is magnified in a new zoom diagram. The original diagram is displayed with the zoom area indicated as a rectangle.

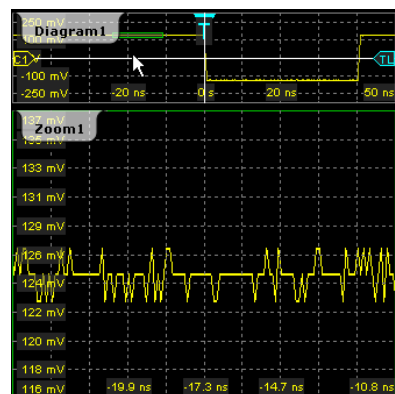

Fig. 5-3: Zoom diagram and overview diagram

3. If the zoom area is not yet placed ideally, adjust the position by dragging the area or with the navigation knob.
 - Drag the rectangle in the overview to the correct position.
 - Turn the navigation knob to shift the zoom area. Press the knob twice to toggle between vertical and horizontal move.

4. If the size of the zoom area is not yet ideal, tap the rectangle in the overview diagram. The rectangle is replaced by 4 lines that indicate the edges of the zoom area.

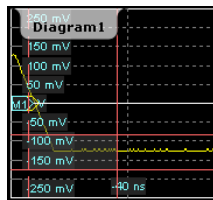

Fig. 5-4: Zoom area indicated by edges

Tip: Tapping the zoom area toggles between area and edge adjustment. You can also press the ENTER key to activate the edge adjustment, and the ESC key to activate the area adjustment.

5. Shift the individual edges to change the size of the zoom area.
 - a) Tap the edge you want to move, or press the navigation knob until the required edge is selected.
 - b) Move the edge by dragging it, or turn the navigation knob.

Tip: In area adjustment mode, you can also adjust the size of the zoom area. Press the navigation knob to toggle between: horizontal position > horizontal span > vertical position > vertical span.



To optimize the zoom definition of an active zoom diagram, double-tap the zoom diagram. The "Zoom" dialog box for numeric definition is opened.

To define the zoom area numerically using start-stop values

1. On the "Display" menu, tap "Zoom".
2. Select the **Start/Stop** tab.
The fields in this dialog box only become editable after you have created a zoom area using the "Zoom" tool in the tool bar, or after you have created a new zoom definition.
To create a new zoom definition:
 - a) Tap the "Add" icon.
 - b) Enter a name for the new zoom diagram using the displayed on-screen keyboard.
3. Under "Vertical mode", select whether you want to define absolute or relative y-axis values. Relative values cause the zoom area to adapt to the input values dynamically.
4. Define the "Start" and "Stop" values that define the lower and upper borders (respectively) of the zoom area on the y-axis (see [figure 5-1](#)).
5. Under "Horizontal mode", select whether you want to define absolute or relative x-axis values.

6. Define the "Start" and "Stop" values that define the lower and upper borders (respectively) of the zoom area on the x-axis.

When you close the dialog box, the specified area is magnified in a new zoom diagram. The original diagram is displayed with the zoom area indicated as a rectangle (see [figure 5-3](#)).



Displaying the center point or start/stop positions

Depending on the definition mode of the zoom area, the position of the center point or the start or stop position is temporarily displayed in the data entry field in the upper left corner of the screen if you do one of the following:

- Change the "Vertical mode" or "Horizontal mode" setting.
- Press the "Navigation" rotary knob while the "Zoom" dialog box is open.
- Tap the zoom area in the diagram overview.

The data entry field disappears again after a few seconds. To toggle the display between the x- and y-values of the position, press the "Navigation" rotary knob.

To define the zoom area numerically using position and range values

1. On the "Display" menu, tap "Zoom".
2. Select the [Position/Range](#) tab.
The fields in this dialog box only become editable after you have created a zoom area using the "Zoom" tool in the tool bar, or after you have created a new zoom definition.
To create a new zoom definition:
 - a) Tap the "Add" icon.
 - b) Enter a name for the new zoom diagram using the displayed on-screen keyboard.
3. Under "Vertical mode", select whether you want to define absolute or relative y-axis values. Relative values cause the zoom area to adapt to the input values dynamically.
4. Under "Position", define the y-value of the center point of the zoom area (see [figure 5-2](#)).
5. Under "Range", define the height of the zoom area.
6. Under "Horizontal mode", select whether you want to define absolute or relative x-axis values.
7. Under "Position", define the x-value of the center point of the zoom area.
8. Under "Range", define the width of the zoom area.

When you close the dialog box, the specified area is magnified in a new zoom diagram. The original diagram is displayed with the zoom area indicated as a rectangle.

To define multiple zoom areas

You can define more than one zoom area for the same diagram, for example to compare several peaks in a measurement. These zoom areas can be displayed in separate zoom diagrams, or together in one zoom diagram.

To define multiple zoom areas graphically, simply repeat the steps described in [To define the zoom area graphically](#) - for each area. Numerically, proceed as follows:

1. On the "Display" menu, tap "Zoom".
2. Select the required tab according to the method you want to use to define the zoom area.
3. Tap the "Copy" icon to copy the current zoom area definition or tap the "Add" icon to add a new zoom area.
4. Enter a name for the new zoom diagram using the displayed on-screen keyboard.
5. Define the zoom area as described for the first zoom.

An additional zoom diagram is displayed for the new zoom area, and another rectangle in the original diagram indicates the new zoom area. Each rectangle in the overview has the same color as the corresponding zoom diagram frame.

6. In the "Zoom" dialog box, enable "Zoom overlay".

The zooms are shown in the same zoom diagram, as if the zoom areas are overlaid.

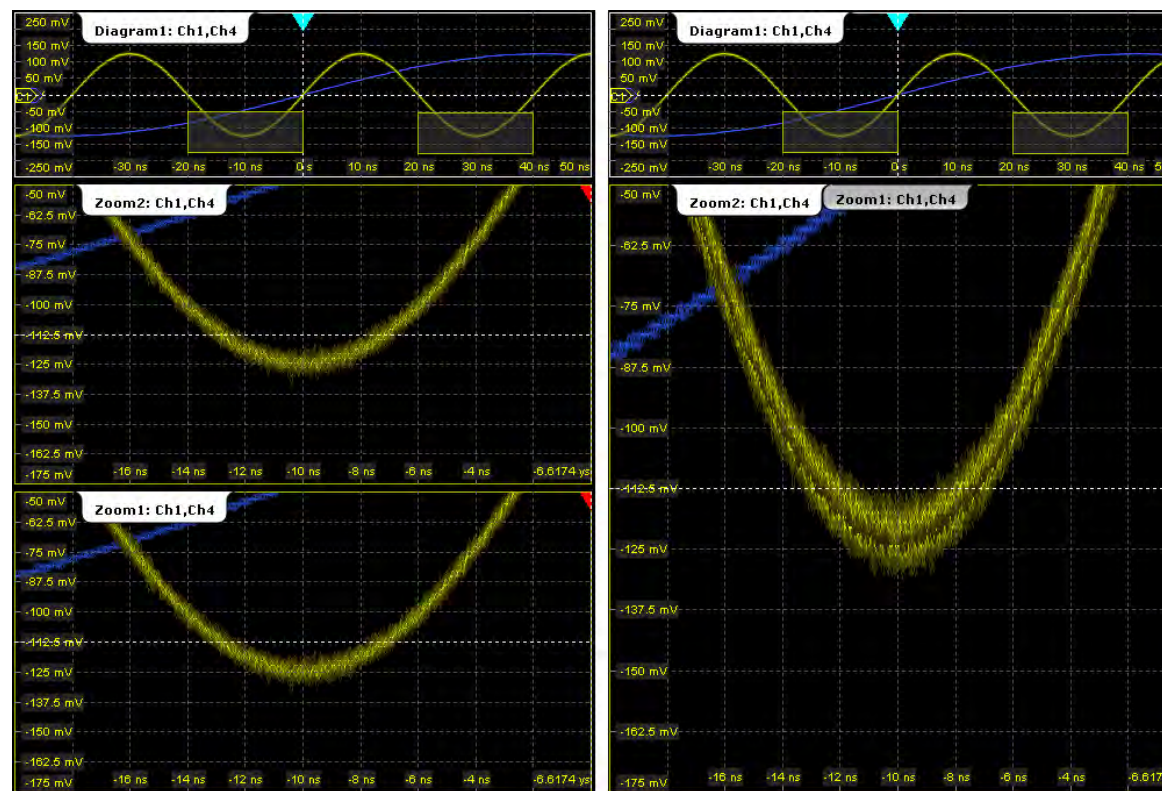

Fig. 5-5: Multiple zoom diagrams. Left: separate zoom diagrams. Right: overlaid zoom

To define coupled zoom areas

You can define multiple zoom areas for one diagram that are coupled, i.e. if you change the size of one zoom area, the size of all coupled zoom areas is changed as well. Furthermore, you can couple also the position in order to move all coupled zooms at once. This is useful, for example, if you want to compare recurring peaks in a signal.

1. On the toolbar, tap the "Coupled Zoom" icon.



2. In the diagram overview, tap an existing zoom area.

The selected zoom area is duplicated.

3. Drag the duplicate zoom area to the required position.

4. To create further coupled zooms, repeat the steps above.

Now if you edit the zoom area size for any of the coupled zoom areas in the "Zoom" dialog box (for example the range) or by dragging the edges on the touch screen, the settings are changed for all of them.

5. In the "Zoom" dialog box, select the diagram for which the coupled zooms are defined, and select a zoom tab.

6. Enable "Position coupling".

Now if you move one of the coupled zoom areas in the diagram, all other coupled zoom areas are moved as well, and their distance is kept unchanged.

To close the zoom diagram

- ▶ Tap the "Delete" icon on the toolbar, then tap the zoom diagram.

The diagram in the overview diagram returns to the original display size.

To use the hardware zoom

In contrast to the normal zoom, the hardware zoom changes the instrument settings - horizontal and vertical scales, and also the trigger level and offset - to display the selected area in the diagram instead of the original waveform. No additional zoom diagram is opened.

1. On the toolbar, tap the "Hardware Zoom" icon.



2. Drag your finger on the touch screen to mark the zoom area.

A dotted rectangle is displayed to indicate the current zoom area. When the rectangle covers the required zoom area, remove your finger. The diagram changes and shows the magnified area.

Tip: To return to the previous display, use the "Undo" icon.

Note: You can combine hardware zoom and normal zoom - first use the hardware zoom, then the zoom into the display. The reverse approach is also possible: Create a zoom diagram, and then apply the hardware zoom to the waveform diagram. Both the waveform and the zoom diagrams are changed.

5.2.3 Reference for Zoom

The zoom area, i.e. the section to be enlarged, can be defined using two different methods:

- Specifying **start and stop values** for the x- and y-axes; the acquired data within those values is zoomed.
- Specifying the x- and y-**position** of one point in the diagram plus a **range** for the x- and y-axes; the area defined by that center point and the ranges is zoomed.



Note that the fields in this tab only become editable after you have created a zoom area using the "Zoom" tool in the tool bar, or after you have created a new zoom definition via the "Add" icon in the dialog box.

5.2.3.1 Zoom Functions on the Toolbar



Hardware zoom

Changes the instrument settings - horizontal and vertical scales as well as trigger level and offset - to display a part of the diagram in greater detail.



Zoom

Displays a magnified section of the diagram in an additional zoom diagram. It is a display zoom, instrument settings are not changed.

Touch and hold the zoom area to open the "Zoom" dialog box.

Remote command:

[LAYout : ZOOM : ADD](#) on page 762



Coupled zoom

Creates a coupled zoom area and its related zoom diagram. If you change the size of one zoom area, the size of all coupled zoom areas is changed as well.

Remote command:

[LAYout : ZOOM : ADDCoupled](#) on page 762

5.2.3.2 Start/Stop

The "Start/Stop" tab allows you to specify start and stop values for the x- and y-axes. The acquired data within these ranges is zoomed.

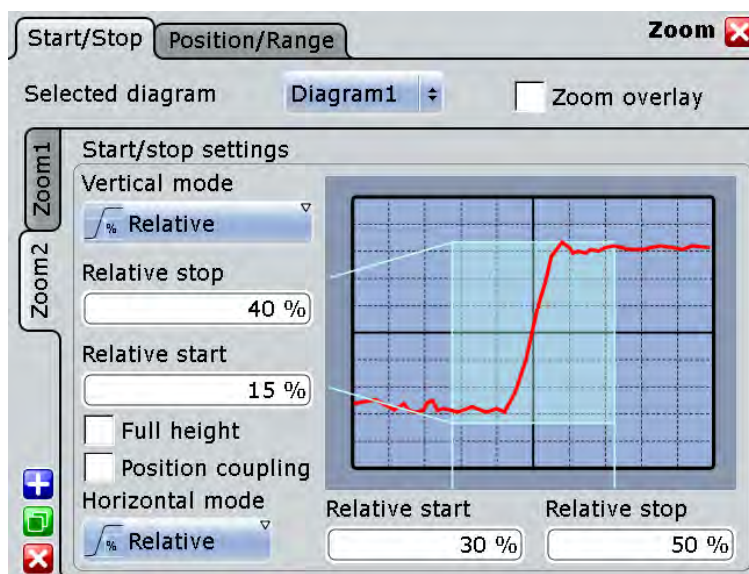

Selected diagram

Indicates which of the waveform diagrams is selected for zooming.

Zoom overlay

Shows all zooms of a diagram in one zoom window. The zoomed areas are overlaid for better comparison of the zoomed waveforms.

The setting affects all zoom diagrams.

Remote command:

[LAYout:ZOOM:ONEDiagram](#) on page 763

Vertical

Defines whether absolute or relative values are used to specify the y-axis values.

Remote command:

[LAYout:ZOOM:VERTical:MODE](#) on page 766

[SEARch:RESDiagram:VERT:MODE](#) on page 910

Stop / Relative stop

Defines the upper limit of the zoom area on the y-axis.

Remote command:

[LAYout:ZOOM:VERTical:RELative:STOP](#) on page 768

[LAYout:ZOOM:VERTical:ABSolute:STOP](#) on page 767

Start / Relative start

Defines the lower limit of the zoom area on the y-axis.

Remote command:

[LAYout:ZOOM:VERTical:RELative:START](#) on page 768

[LAYout:ZOOM:VERTical:ABSolute:START](#) on page 767

Full height

Uses the full diagram height for the zoom area. Only horizontal zoom settings can be changed.

Position coupling

Enables or disables the position coupling of coupled zooms. If position coupling is enabled and you move one zoom area, the other coupled zoom areas are moved, too, and keep their distance.

Remote command:

[LAYout:ZOOM:POSCoupling](#) on page 763

Horizontal

Defines whether absolute or relative values are used to specify the x-axis values.

Remote command:

[LAYout:ZOOM:HORIZ:MODE](#) on page 763

[SEARCh:RESDiagram:HORIZ:MODE](#) on page 908

Start / Relative start

Defines the lower limit of the zoom area on the x-axis.

Remote command:

[LAYout:ZOOM:HORIZ:ABSolute:START](#) on page 764

[LAYout:ZOOM:HORIZ:RELative:START](#) on page 765

Stop / Relative stop

Defines the upper limit of the zoom area on the x-axis.

Remote command:

[LAYout:ZOOM:HORIZ:ABSolute:STOP](#) on page 764

[LAYout:ZOOM:HORIZ:RELative:STOP](#) on page 766

5.2.3.3 Position/Range

In the "Position/Range" tab, you specify the x- and y-position of center point of the zoom area plus a range for the x- and y-axes; the area defined by that point and the ranges is zoomed.

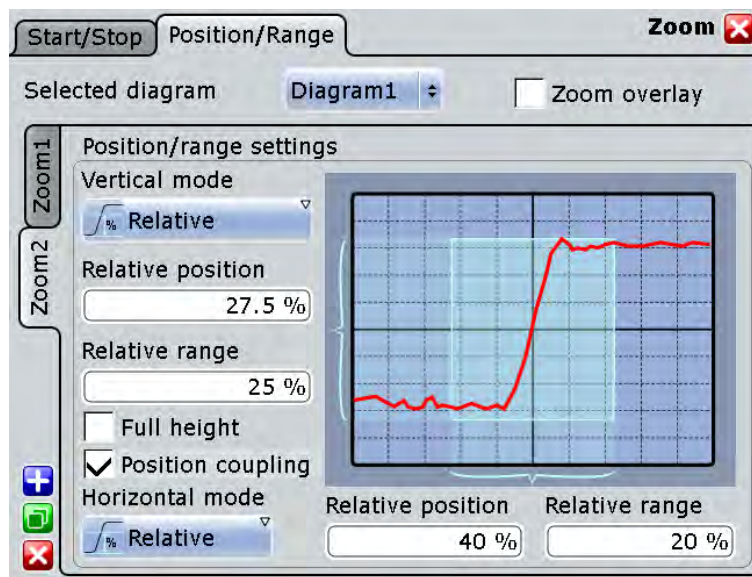

Vertical

Defines whether absolute or relative values are used to specify the y-axis values.

Remote command:

[LAYout:ZOOM:VERTical:MODE](#) on page 766

[SEARCh:RESDiagram:VERT:MODE](#) on page 910

Position / Relative position (vertical)

Defines the y-value of the centerpoint of the zoom area.

Remote command:

[LAYout:ZOOM:VERTical:ABSolute:POSition](#) on page 766

[LAYout:ZOOM:VERTical:RELative:POSition](#) on page 767

[SEARCh:RESDiagram:VERT:ABSolute:POSition](#) on page 909

[SEARCh:RESDiagram:VERT:RELative:POSition](#) on page 910

Range / Relative Range (vertical)

Defines the height of the zoom area.

Remote command:

[LAYout:ZOOM:VERTical:RELative:SPAN](#) on page 768

[LAYout:ZOOM:VERTical:ABSolute:SPAN](#) on page 767

[SEARCh:RESDiagram:VERT:ABSolute:SPAN](#) on page 910

[SEARCh:RESDiagram:VERT:RELative:SPAN](#) on page 910

Full height

Uses the full diagram height for the zoom area. Only horizontal zoom settings can be changed.

Position coupling

Enables or disables the position coupling of coupled zooms. If position coupling is enabled and you move one zoom area, the other coupled zoom areas are moved, too, and keep their distance.

Remote command:

[LAYout:ZOOM:POSCoupling](#) on page 763

Horizontal

Defines whether absolute or relative values are used to specify the x-axis values.

Remote command:

[LAYout:ZOOM:HORIZ:MODE](#) on page 763

[SEARch:RESDiagram:HORIZ:MODE](#) on page 908

Position / Relative position (horizontal)

Defines the x-value of the centerpoint of the zoom area.

Remote command:

[LAYout:ZOOM:HORIZ:ABSolute:POSition](#) on page 763

[LAYout:ZOOM:HORIZ:RELative:POSition](#) on page 765

Range / Relative Range (horizontal)

Defines the width of the zoom area.

Remote command:

[LAYout:ZOOM:HORIZ:ABSolute:SPAN](#) on page 764

[LAYout:ZOOM:HORIZ:RELative:SPAN](#) on page 765

[SEARch:RESDiagram:HORIZ:ABSolute:SPAN](#) on page 908

[SEARch:RESDiagram:HORIZ:RELative:SPAN](#) on page 909

5.3 XY-diagram

XY-diagrams combine the voltage levels of two waveforms in one diagram. They use the voltage level of a second waveform as the x-axis, rather than a time base. This allows you to perform phase shift measurements, for example. You can display up to four different XY-diagrams.

XY-diagrams can be used to display the IQ representation of a signal.

5.3.1 Displaying an XY-diagram

You can create the diagram from active waveforms with drag&drop, or use the dialog box for setup.

To display an XY-diagram with drag&drop

Prerequisites: The source waveform for the y-axis is active in a diagram, the source waveform for the x-axis is either active or minimized.

1. Drag the x-axis waveform to the lower left corner of the diagram with the y-axis waveform.
2. Drop the icon when it overlaps the left and lower diagram borders.

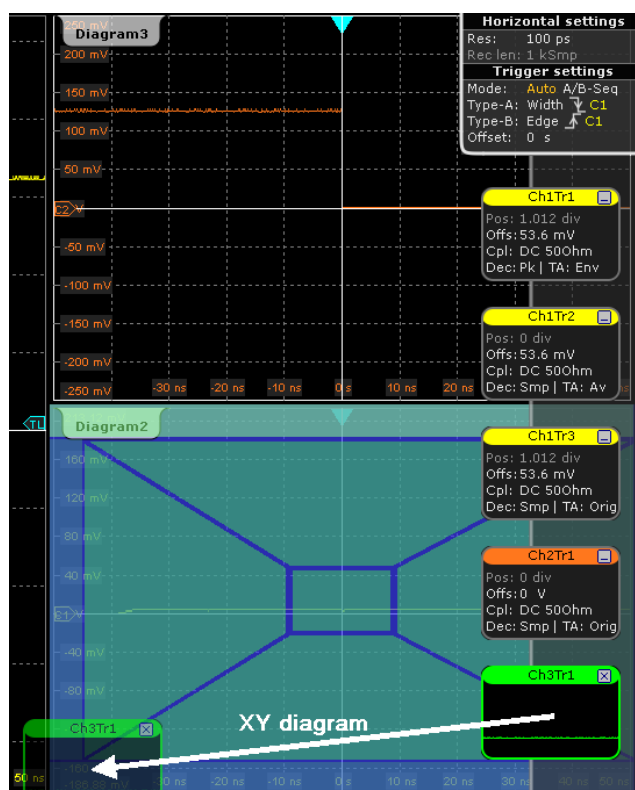

The diagram is converted into an XY-diagram.

To set up an XY-diagram

1. On the "Display" menu, tap "XY-diagram".
2. Activate the "State" option.
3. In the "X-source" field, define the signal source that supplies the x-values of the XY-diagram. Select one of the following:
 - One of the waveforms of any channel
 - A reference waveform
 - The results of a mathematical function
4. In the "Y-source" field, define the signal source that supplies the y values of the XY-diagram.
5. To switch the x- and y-values quickly, tap the "Swap XY" button.

- In order to maintain a constant ratio while the x- and y-axes are adapted to the acquired data dynamically, activate the "Constant XY-ratio" option.



If the XY-diagram is active or minimized, touch and hold the signal icon to open the "XY-diagram" tab.

5.3.2 Reference for XY-diagram

You can display up to four different XY-diagrams that use the voltage level of a waveform as the x-axis, rather than a time base.



Make sure to select the tab of the required XY-diagram.



Enable

If activated, the XY-waveform is active and shown in a diagram, or it is minimized in a signal icon.

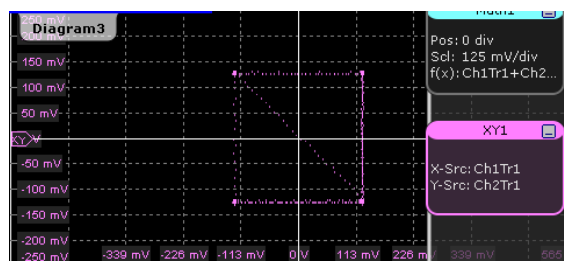

Remote command:

[WAVEform<m>:XYCurve:STATe](#) on page 769

X-source

Defines the signal source that supplies the x-values of the XY-diagram. Select one of the following:

- One of the waveforms of any channel
- A reference waveform
- The results of a mathematical function

Remote command:

[WAVeform<m>:XYCurve:XSource](#) on page 770

Y-source

Defines the source to be used as the y-axis of the XY-diagram. Select one of the following:

- One of the waveforms of any channel
- A reference waveform
- The results of a mathematical function

Remote command:

[WAVeform<m>:XYCurve:YSource](#) on page 770

Constant XY-ratio

If enabled, the x- and y-axes maintain a constant ratio in the diagram.

Remote command:

[WAVeform<m>:XYCurve:RATio](#) on page 769

Swap XY

Replaces the source of the x-axis with the source of the y-axis and vice versa.

Remote command:

[WAVeform<m>:XYCurve:SWAP](#) on page 770

5.4 History

The history accesses the data of previous acquisitions and provides them for further analysis.

5.4.1 About History

If a continuous acquisition runs, the captured data is stored in the sample memory and the current acquisition is processed and shown on the display. After the acquisition was stopped, the history accesses the captured samples that were stored, displays these samples as history waveforms, and makes them available for further analysis. It considers all channels that were enabled during the running acquisition. When a new acquisition is started with RUN CONT or RUN xSINGLE, the memory is cleared and written anew.

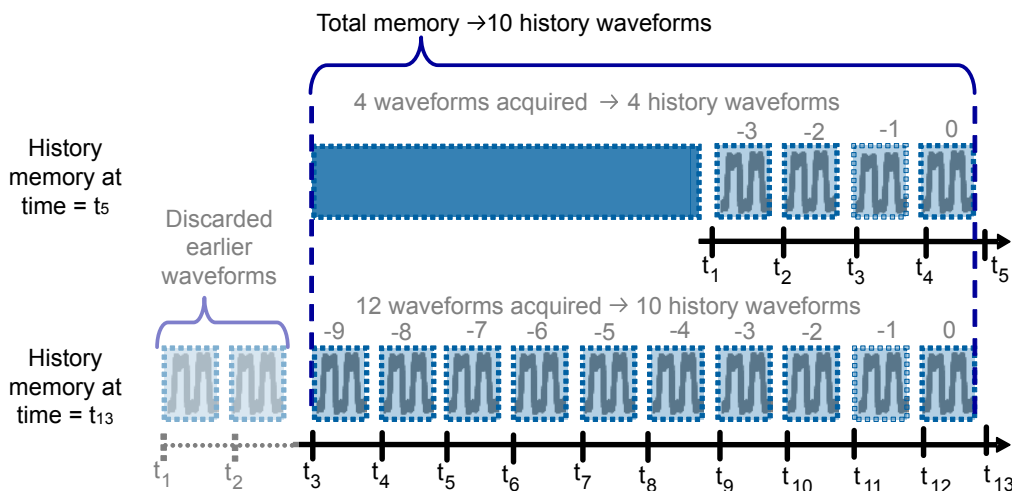

Fig. 5-6: History memory. In this example, the memory can store 10 waveforms.

You can work with history waveforms in the same way as with the waveform of the latest acquisition: use zoom, cursor measurements, and automatic measurements, create math waveforms, perform mask testing and so on. Saving the history data is also possible, either completely or a part of the data.

The number of stored history waveforms depends on the memory size, the number of enabled channels, and the record length. The shorter the record length, the less the number of channels, and the larger the memory, the more history waveforms are saved. The memory can be enhanced with optional memory extension: 50 MSa with RTO-B101 100 MSa with RTO-B102.

History and equivalent time sampling are mutually exclusive, waveforms acquired with equivalent time sampling have no history.

Quick-access History dialog box

When you press the HISTORY key on the front panel or tap "Display" menu > "Show history", the history mode is enabled and the quick-access "History" dialog box is displayed. A running acquisition stops immediately.

The small quick-access "History" dialog box can remain visible on the screen during history replay, so that the history can be replayed at any time by a simple tap on the "Play" button. Closing the quick-access "History" dialog box, or starting a new acquisition disables the history mode.



5.4.2 Using History

You can access the history waveforms in two ways:

- Display a particular acquisition.
- Replay all or a part of the saved waveforms to track the signal run.

Furthermore, you can export history data to a file.

- ["To open the history and get information"](#) on page 209
- ["To display a particular acquisition"](#) on page 209
- ["To replay history waveforms"](#) on page 210
- ["To exit the history"](#) on page 210
- ["To save the history"](#) on page 210

To open the history and get information

1. Press the HISTORY key on the front panel. A running acquisition is stopped, the history mode is enabled and the quick-access "History" dialog box is displayed.
The HISTORY key is illuminated as long as the history mode is active.
2. Open the full configuration dialog box:
 - Tap the  icon.
 - Press the HISTORY key again.
 - On the "Display" menu, tap "History setup".
3. In the "History" configuration dialog box, select the "Information" tab to see how many history waveforms are saved, and how many can be saved as maximum.

To display a particular acquisition

1. In the quick-access "History" dialog box, enter the number of the required acquisition in the "Current index" field. The newest acquisition always has the index "0", older acquisitions have a negative index
2. Tap "Play" to start.

Alternatively, you can configure and start the history display from the "History" configuration dialog box:

1. Open the "History" configuration dialog box and select the "Viewer" tab.
2. If the history mode is off (the HISTORY key is not illuminated), select "Show history".
The quick-access dialog box is displayed.
3. Drag the slider to the required acquisition. The current number is shown in the "Current index" field.
Alternatively, enter the number of the required acquisition in the "Current index" field.
4. Tap "Play" to start.

To replay history waveforms

If you want to see the complete acquisition series without any setup, simply tap "Play" in the quick-access "History" dialog box. For specific analysis of history data, use the history "Viewer" setup.

1. In the "History" configuration dialog box, select the "Viewer" tab.
2. If the history mode is off (the HISTORY key is not illuminated), enable "Show history".
The quick-access dialog box is displayed.
3. Define the part of the history you want to see by doing one of the following:
 - Tap "Select all" to see the complete history.
 - Enter the "Start Index" of the oldest acquisition to display and the "Stop Index" of the newest acquisition to display. All waveforms between the two indexes will be displayed.
To enter the oldest or newest acquisition for either index, tap the appropriate button. The newest acquisition always has the index "0". The "Start index" is always negative.
4. Tap "Play" to start.

To exit the history

- Choose one of the following ways:
- Close the quick-access "History" dialog box.
 - On the "Display" menu, tap "Show history".
 - In the "Viewer" tab, disable "Show history".
 - Start the acquisition.

To save the history

You can save the complete history, or some subsequent waveforms from the history, or a single history waveform. You can also decide to save the complete waveforms, or a part of each waveform.

1. Press the FILE key.
2. Select the "Save/Recall" tab.
3. Select the "Waveform" tab.
4. Tap the source icon to select the waveform you want to save.
5. If you want to save only a part of each waveform, set the "Scope".
For settings, see ["Scope"](#) on page 376.
6. Enable "Export history".
7. To save one waveform out of the history:
 - a) Make sure that "Multiple Wfms" is disabled.

- b) Enter the number of the required acquisition in "Acq index". The newest acquisition in the memory always has the index "0". Older acquisition have a negative index.
 - c) Tap "Save" or "Save As" to save the waveform data to the specified file.
8. To save several subsequent history waveforms:
- a) Enable "Multiple Wfms".
 - b) Define the range of the waveforms to be saved with "Start acq" and "Stop acq".
 - c) Tap "Start Export" to play the history and to save the history data to the specified file.

5.4.3 Reference for History

The "History" dialog box contains the complete functionality on history viewing and information. Out of these, the most important information and functions are also provided in the quick-access history dialog box.

5.4.3.1 Viewer

The settings in the "Viewer" tab control the display of history waveforms.



The numbering of the waveforms refers to the current memory content. With every RUN CONT or RUN xSINGLE action, the memory content changes.

Show history / Export history

Enables the history mode and allows to save history waveforms to file.

The history display is enabled automatically when you press the HISTORY button. It is disabled when you close the quick-access "History" dialog box.

For details on data export, see ["Export history"](#) on page 377.

Remote command:

`CHANnel<m>[:WAVEform<n>]:HISTory[:STATe]` on page 771

Current acq

Accesses a particular acquisition in the memory to display it, or to save it. The newest acquisition always has the index "0". Older acquisition have a negative index.

If a history replay is running, the field shows the number of the currently shown acquisition.

Remote command:

`CHANnel<m>[:WAVeform<n>]:HISTory:CURRent` on page 771

Start acq

Sets the index of the first (oldest) acquisition to be displayed or exported. The index is always negative. The number of stored history acquisitions is shown in [Available acquisitions](#) on the "Information" tab.

Remote command:

`CHANnel<m>[:WAVeform<n>]:HISTory:STARt` on page 772

Stop acq

Sets the index of the last (newest) acquisition to be displayed or exported. The newest acquisition of the complete acquisition series always has the index "0".

Remote command:

`CHANnel<m>[:WAVeform<n>]:HISTory:STOP` on page 772

Select all

All acquisitions saved in the memory will be shown in the viewer.

Current

Sets the newest acquisition in the sample memory as "Stop acq" and "Current acq". This acquisition always has the index "0".

Oldest

Sets the oldest acquisition in the sample memory as "Start acq" and "Current acq".

Auto repeat

If selected, the replay of the history waveform sequence repeats automatically. Otherwise, the replay stops at the "Stop index".

Remote command:

`CHANnel<m>[:WAVeform<n>]:HISTory:REPLay` on page 773

Play

Starts and stops the replay of the history waveforms from "Start acq" to "Stop acq".

Remote command:

`CHANnel<m>[:WAVeform<n>]:HISTory:PLAY` on page 773

Time per acquisition

Sets the display time for one acquisition. The shorter the time, the faster is the replay. The setting takes effect for history replay and the display of an Ultra Segmentation series, see [chapter 3.3.1.4, "Ultra Segmentation"](#), on page 113.

Remote command:

`CHANnel<m>[:WAVeform<n>]:HISTory:TPACq` on page 773

Time stamp

The time stamp shows the time of the currently displayed history acquisition. Thus, the time relation between acquisitions is always available.

The time stamp "Mode" can be absolute or relative:

- In "Absolute" mode, the instrument shows the date and the daytime of the current acquisition.
- In "Relative" mode, the time difference to the newest acquisition (index = 0) is shown.

During history replay, the time value is displayed and updated if the replay speed ("Time per acquisition") is slow enough, that is 40 ms or slower.

The quick-access history dialog box always shows the relative time. In the "History Viewer" tab, you can select the time mode.

Remote command:

[CHANnel<m>\[:WAVeform<n>\]:HISTory:TSDate?](#) on page 774

[CHANnel<m>\[:WAVeform<n>\]:HISTory:TSABsolute?](#) on page 774

[CHANnel<m>\[:WAVeform<n>\]:HISTory:TSRelative?](#) on page 774

5.4.3.2 Information**Max. acquisition count**

Displays the maximum number of acquisitions that can be saved in the sample memory and displayed with the history viewer. With Ultra Segmentation, it is also the maximum number of acquisitions in an Ultra Segmentation acquisition series.

Available acquisitions

Displays the number of acquisitions currently saved in the sample memory. This memory is also used to save an Ultra Segmentation acquisition series, so the number of acquisitions available for history viewing is the same as the number of acquisitions in an Ultra Segmentation acquisition series.

Remote command:

[ACQuire:AVAILable?](#) on page 771

6 Reference Waveforms

6.1 Working with Reference Waveforms

You can configure up to four reference waveforms to display stored waveforms. Any active signal or mathematical waveform can be stored as a reference waveform. It can then be loaded again later to restore the waveform on the screen.

To display a reference waveform

Reference waveforms can be displayed in addition to the signal waveforms.

1. In the "Math" menu, select "Reference Waveform > Setup", or press the REF key.
2. Select the tab for the reference waveform you want to display ("Ref1"- "Ref4").
3. Load a stored reference waveform as described in ["To load a reference waveform"](#) on page 215, or select a source to be displayed as a reference:
 - a) In the "Reference" tab, tap the "Selected source" icon and select a source from the selection list. The source can be any active signal, math, or other reference waveform.
 - b) Tap the "Update with" button to update the current reference waveform with the source data.
4. Tap the "Show reference waveform" icon so it is highlighted.
The reference waveform is displayed on the screen.
5. A reference waveform can have its own scaling settings or it can be scaled according to the source settings. By default, the scaling of the reference waveform is coupled to the source settings. Additionally, it can be stretched or compressed in vertical and horizontal direction.
If necessary, change the settings on the "Scaling" tab of the "Reference Waveform" dialog box. The original source waveform settings are displayed in the "Original Attributes" tab. To restore the original settings, tap the "Restore settings" button.
For a description of the scaling settings, see [chapter 6.2.2, "Scaling"](#), on page 217.

To save a reference waveform

1. In the "Math" menu, select "Reference Waveform > Setup", or press the REF key.
Tip: Alternatively, you can save a waveform as a reference waveform in the "File" dialog box, see [chapter 11.1.2, "Saving and Loading Waveform Data"](#), on page 361.
2. Select the tab for the reference waveform you want to store ("Ref1"- "Ref4").
3. Display and configure the reference waveform as described in ["To display a reference waveform"](#) on page 214.
4. Select the file format.

Note: Reference waveforms can be loaded only from BIN files. XML and CSV formats are meant for further processing in other applications.

5. To save the waveform to the currently selected file, tap "Save". By default, the prefix for reference waveform files is "RefCurve".

To save the waveform to another file, select "Save As".

Enter a file name and select the directory. The file type is already defined according to the selection in the previous step. In order to load the reference waveform on the instrument again later, use the file type BIN.

The source settings of the reference waveform and the current scaling settings are stored to the specified file.

To load a reference waveform

Note: Reference waveforms can be loaded only from BIN files.

1. In the "Math" menu, select "Reference Waveform > Setup", or press the REF key.
2. Select the tab for the reference waveform you want to load ("Ref1" - "Ref4").
3. To load the waveform from the specified file, tap "Load".
To load the waveform from a different file, tap "Open". Select the file from the file selection dialog box. Only BIN files are displayed in the file list.
The selected waveform is loaded as the specified reference waveform.
4. If the reference waveform is not visible, tap the "Show reference waveform" icon.

6.2 Reference Waveforms

To compare waveforms and analyze differences between waveforms, you can use up to four reference waveforms R1 to R4. Each reference waveform has its own memory on the instrument. You can also save an unlimited number of reference waveforms and load them for further use.

The display of a reference waveform is independent from that of the source waveform; you can move, stretch and compress the curve vertically and horizontally. Reference waveforms are configured in the "Reference Waveform" dialog box, which is displayed when you press the REF key or select "Math > Reference curves" from the menu.

6.2.1 Reference tab

In the "Reference" tab, you select the reference waveform and its source. The source is an active waveform - trace of an input channel, math waveform or another reference waveform - or a stored waveform.

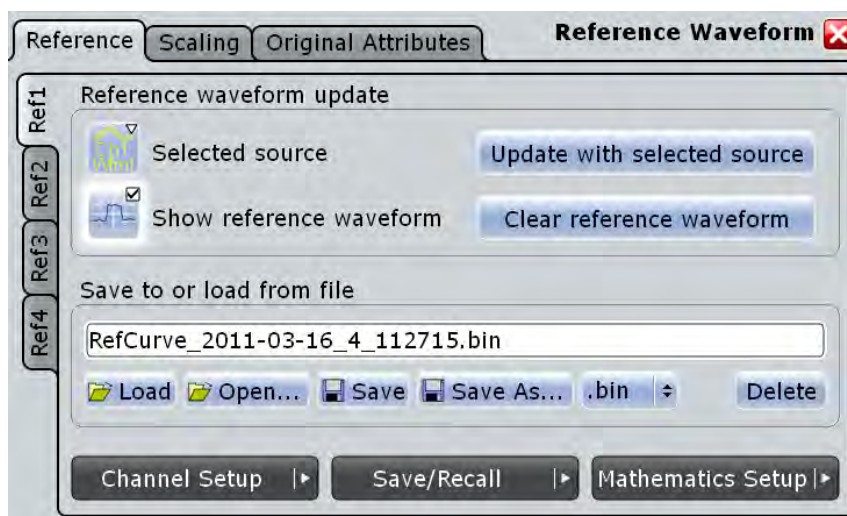

Ref 1/2/3/4.....216
 Source.....216
 Update with selected source.....216
 Show reference waveform.....216
 Clear reference waveform.....216
 Save to or load from file.....217

Ref 1/2/3/4

Each tab contains the settings for one of the four available reference waveforms.

Source

Selects the source waveform from the active waveforms of input channels, math signals and other reference waveforms.

Remote command:

[REFCurve<m>:SOURce](#) on page 775

Update with selected source

Copies the selected source waveform with all its settings to the memory of the reference waveform. If the acquisition is running, the reference waveform is a snapshot.

Remote command:

[REFCurve<m>:UPDate](#) on page 776

Show reference waveform

Displays the reference waveform in the diagram.

Remote command:

[REFCurve<m>:STATe](#) on page 775

Clear reference waveform

The selected reference waveform disappears, its memory is deleted.

Remote command:

[REFCurve<m>:CLEar](#) on page 777

Save to or load from file

Enter the file name of the stored reference waveform and select the file format with the format button on the right. Double-tap the file name to open the file selection dialog box, see also [chapter 11.2.4, "File Selection Dialog"](#), on page 386.

By default, the file name has the prefix "RefCurves_". You can define a pattern for automatic naming in the "Autonaming" tab.

Note: Note that reference waveforms can be loaded from `.bin` files only. `xml` and `csv` formats are meant for further processing in other applications.

"Load"	Loads the specified reference waveform.
"Open"	Opens a file selection dialog box and loads the selected reference waveform file
"Save"	Saves the waveform as a reference waveform in the selected file.
"Save As..."	Opens the file selection dialog box and saves the waveform to the selected file.
".bin/.xml/.csv"	Selects the file format.

Remote command:

`REFCurve<m>:OPEN` on page 776

`REFCurve<m>:SAVE` on page 776

`REFCurve<m>:DELete` on page 777

6.2.2 Scaling

A reference waveform can have its own settings, for example, vertical position and scale. Additionally, it can be stretched or compressed in vertical and horizontal direction. The current settings and the settings of the source waveform are stored.

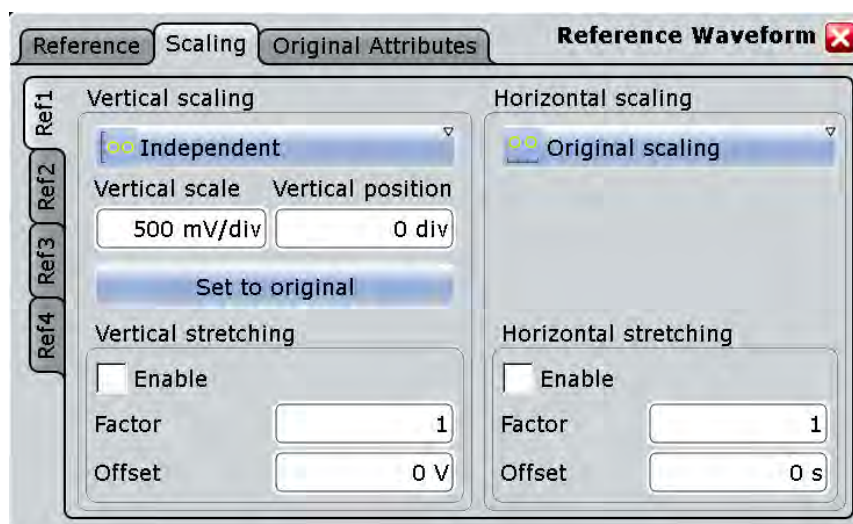
**Vertical Scaling**

Selects the type of vertical settings:

"Coupled to source" Vertical position and scale of the source are used.

"Independent" Scaling and position can be set specific to the reference waveform.

Remote command:

[REFCurve<m>:VMODE](#) on page 777

Vertical scale

Sets the scale factor for the reference waveform, if vertical scaling is set to "Independent".

Remote command:

[REFCurve<m>:SCALE](#) on page 778

Vertical position

Moves the reference waveform up or down in the diagram, if vertical scaling is set to "Independent".

Remote command:

[REFCurve<m>:POSITION](#) on page 778

Set to original

Restores the settings of the source waveform, if vertical scaling is set to "Independent".

Remote command:

[REFCurve<m>:RESTore](#) on page 777

Vertical Stretching

Stretching changes the display of the waveform independent of the vertical scale and position.

Enable ← Vertical Stretching

Enables and disables the vertical stretching.

Remote command:

[REFCurve<m>:RESCale:VERTical:STATe](#) on page 778

Factor ← Vertical Stretching

A factor greater than 1 stretches the waveform vertically, a factor lower than 1 compresses the curve.

Remote command:

[REFCurve<m>:RESCale:VERTical:FACTor](#) on page 779

Offset ← Vertical Stretching

Moves the reference waveform vertically. Enter a value with the unit of the waveform. Like vertical offset of a channel waveform, the offset of a reference waveform is subtracted from the measured value. Negative values shift the waveform up, positive values shift it down.

Remote command:

[REFCurve<m>:RESCale:VERTical:OFFSet](#) on page 779

Horizontal Scaling

Selects the type of horizontal settings:

"Adjust to X-Axis" The current horizontal settings of the diagram are used.

"Original Scaling" Horizontal scaling and reference point of the source waveform are used.

Remote command:

[REFCurve<m>:HMODE](#) on page 779

Horizontal Stretching

Stretching changes the display of the waveform independent of the horizontal settings of the source waveform and of the horizontal diagram settings.

Enable ← Horizontal Stretching

Enables and disables the horizontal stretching.

Remote command:

[REFCurve<m>:REScale:HORizontal:STAtE](#) on page 780

Factor ← Horizontal Stretching

A factor greater than 1 stretches the waveform horizontally, a factor lower than 1 compresses the curve.

Remote command:

[REFCurve<m>:REScale:HORizontal:FACTor](#) on page 780

Offset ← Horizontal Stretching

Moves the waveform horizontally. Enter a value with a time unit suitable for the time scale of the diagram. Positive values shift the waveform to the right, negative values shift it to the left.

Remote command:

[REFCurve<m>:REScale:HORizontal:OFFSet](#) on page 780

6.2.3 Original Attributes

As a reference waveform can be scaled, stretched and positioned in the diagram, this tab shows the settings of the original reference waveform for information.

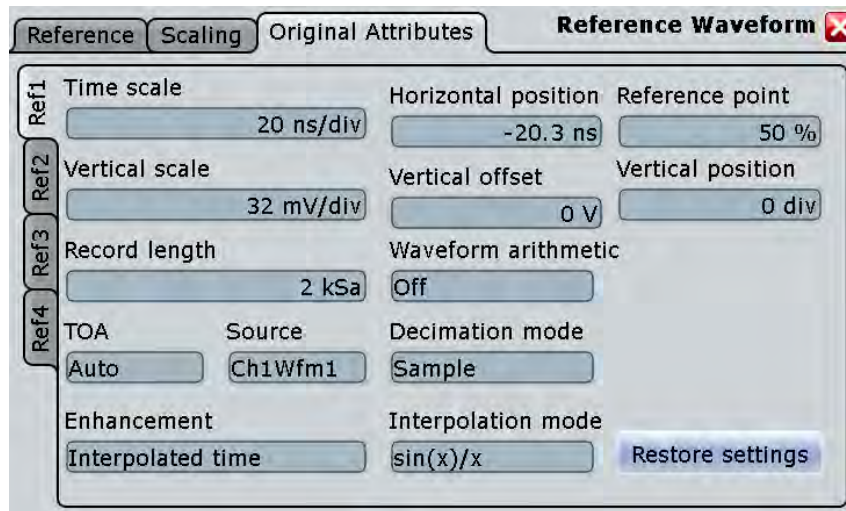

- "Time scale" on page 106
- "Vertical scale" on page 118
- "Resolution / Record length (Time scale dependency)" on page 109
- "Source" on page 216
- "Resolution enhancement" on page 110
- "Horizontal position" on page 106
- "Offset" on page 117
- "Wfm Arithmetic" on page 112
- "Decimation" on page 112
- "Interpolation mode" on page 111
- "Reference point" on page 107
- "Position" on page 118

Restore Settings

Restores the original waveform settings from the source waveform to the reference waveform.

7 Measurements

Using the R&S RTO you can perform and display different measurements simultaneously, based on the active signal or math waveforms. The color of the results in the result table corresponds with the source waveform color.

The following measurement methods are available:

- Cursor measurements (CURSOR key): measurements can be configured for up to four cursor sets to determine specific results at the manually defined cursor positions of an active waveform; the results are displayed in a result box. See [chapter 7.1, "Cursor measurements"](#), on page 221.
- Automatic measurements: up to eight measurements can be configured and performed simultaneously; the results of each measurement are displayed in a result box. See [chapter 7.2, "Automatic Measurements"](#), on page 230.

7.1 Cursor measurements

- [Manual Measurements with Cursors](#).....221
- [Performing Cursor Measurements](#).....222
- [Reference for Cursor Measurements](#).....225

7.1.1 Manual Measurements with Cursors

Cursor measurements determine the results at the current cursor positions. The cursors can be positioned manually or can be configured to follow the peaks of the waveform. Up to four cursor sets can be configured and displayed. Each cursor set consists of a pair of horizontal or vertical cursors, or both. Cursor lines can be coupled so that the initially defined distance is always maintained.

How to set up cursor measurements is described in [chapter 7.1.2, "Performing Cursor Measurements"](#), on page 222. The [chapter 7.1.3, "Reference for Cursor Measurements"](#), on page 225 provides a detailed description of all settings.

Cursors also can define a gate to limit the measurement to the section of the waveform between the cursor lines. See [chapter 7.2.4.8, "Measurements - Gate/Display Tab"](#), on page 275.

Cursor Measurements Results

The results of cursor measurements are displayed in a result box on the screen. For each measurement, a separate result box is displayed. The result box is displayed automatically when a cursor measurement is enabled. Similar to waveform diagrams, you can minimize the result box to a result icon on the signal bar, and display results in a separate diagram on the screen.

For details on using the result box, see "Displaying results" in the "Getting Started" manual.

The following information may be provided in the result box, depending on the selected source.

Label	Description
t1, t2	Time at the position of the vertical cursors. You can change the values directly in the result box.
V1, V2	Vertical values of the waveform at the position of the horizontal cursors in V, A, dB etc. depending on the type of the source waveform. If the cursor lines track the waveform, the measurement result is displayed. If tracking is disabled, you can change the values directly in the result box.
f1, f2	The frequency at the position of the vertical cursors.
Δt	Difference between the vertical cursor (time) values
BW	Difference between the vertical cursor (frequency) values
ΔV	Difference between the horizontal cursor values
$1/\Delta t$	Inverse time difference
$\Delta V/\Delta t$	Slope of the waveform between the cursors
Type	Cursor type - horizontal, vertical, or both
Track waveform	If enabled, the horizontal cursors track the peaks of the waveform
Peak	Peak search function (for spectrum results only, see chapter 7.1.3.3, "Peak Search Tab" , on page 228)

The cursors can be displayed in the source waveform diagram(s). For each measurement, labels can be defined for the cursors. By default, the cursors are labeled as C1.1, C1.2, C2.1, C2.2, C3.1, C3.2, C4.1, C4.2.

7.1.2 Performing Cursor Measurements

Cursor measurements determine the results at the current cursor positions. The cursors can be positioned manually or can be configured to follow the waveform. Up to four sets of cursors can be configured and displayed. Each set of cursors consists of a pair of horizontal or vertical cursors, or both. The cursor display can also be configured.

Cursor measurements can be performed and displayed simply by tapping the "Cursor" icon on the toolbar and then the waveform to be measured.

- [Performing a Simple Cursor Measurement](#).....222
- [Configuring a Cursor Measurement](#).....223
- [Configuring the Cursor Display](#).....224

7.1.2.1 Performing a Simple Cursor Measurement

To display cursors

1. Select the waveform to be measured.

2. Choose one of the following methods:
 - Press the CURSOR key.
 - Tap the "Cursor" icon, and then tap the diagram where you want to set the cursors, or draw a rectangle in the diagram to position the cursor lines.



The cursor lines appear and the "Cursor Results" box for the selected waveform opens.

You can move the cursor lines in the diagram manually, or adjust the cursor type, source and position in the result box.

For details on cursor measurement results, see [chapter 7.1.1, "Manual Measurements with Cursors"](#), on page 221.

To disable all cursor measurements

1. Press the CURSOR key.
2. Select the "Cursor Setup" tab.
3. Tap the "All Off" button.

All cursor measurements are disabled, the cursors and cursor result boxes are removed from the display.

7.1.2.2 Configuring a Cursor Measurement

1. If a cursor measurement was already enabled via the toolbar icon or CURSOR key, tap the  icon in the result box, or press the CURSOR key to display the "Cursor Setup" dialog box. Otherwise, from the "Cursor" menu, select "Setup".
2. Select the "Cursor Setup" tab.
3. Select the tab for the cursor set you want to perform a measurement on.
4. Tap the "Source" icon and select a waveform for which the measurement is to be performed. Any input channel, math, reference or XY-waveform can be selected. If you enabled the cursor measurement via the toolbar icon or CURSOR key, the source is automatically defined as the selected or active waveform.
5. Select the icon for the type of cursors to be used - horizontal, vertical, or both.
6. Define the position of the cursors.
 - a) To define the position of the cursors manually, enter the X-position for each vertical cursor and the Y-position for each horizontal cursor. Horizontal cursors can only be positioned manually if the "Track waveform" setting is disabled.

- b) To position the horizontal cursors automatically, select "Track waveform". In this case, cursor 1 indicates the current maximum, cursor 2 indicates the current minimum. If both horizontal and vertical cursors are displayed, the horizontal cursors are placed at the crossing points of the vertical cursors with the waveform. The vertical cursors must be positioned manually.
If the waveform arithmetics are set to "Envelope" and the "Trace Curve" setting is enabled, select which horizontal cursor is positioned to the maximum and which to the minimum envelope values. Under "Envelope wfm selection 1", select the crossing point for cursor 1. Under "Envelope wfm selection 2", select the crossing point for cursor 2.
- c) To maintain the distance between the vertical cursors when one cursor is moved, select the "Coupling" option.
- d) To set the cursors for a spectrum measurement to peak values automatically, select the "Peak Search" tab.
Optionally, define a peak excursion, i.e. the minimum level value by which the waveform must rise or fall so that it will be identified as a maximum or a minimum by the search functions.
Tap one of the search function buttons to place the cursor(s) on the selected peak value. For details see [chapter 7.1.3.3, "Peak Search Tab"](#), on page 228.

When you close the dialog box you can move the cursors on the touchscreen manually; the results are adapted accordingly.

- 7. Optionally, select "Show in all diagrams" in the "Setup" tab to enable the cursor display for all waveform diagrams based on the same domain (time or spectrum) as the selected source, for example a zoom or XY-diagram.
- 8. Tap the "Enable" icon in the "Setup" tab to activate the cursor measurement.
The cursors are displayed in the waveform diagram(s) of the measurement source and the "Cursor" result box is displayed. For details on cursor measurement results, see [chapter 7.1.1, "Manual Measurements with Cursors"](#), on page 221.

7.1.2.3 Configuring the Cursor Display

By default, the cursors are displayed as lines in the diagrams and labeled according to the syntax:

C<cursor set number>.<1|2>

The cursors for the cursor set 3, for example, are labeled 3.1 and 3.2. Both the horizontal and the vertical cursors have the same labels.

You can change the default cursor display.

1. Press the CURSOR key.
2. Select the "Cursor Style And Label" tab.
3. Select the tab for the cursor set you want to configure.

4. For each vertical and horizontal cursor enter a label to be displayed in the diagrams.
5. Select "Show labels".
6. To display only the crossing points of the cursors with the waveform, select the cursor style "Rhombus".
To display both the crossing points and the cursor lines, select the cursor style "Line & Rhombus".

7.1.3 Reference for Cursor Measurements

Cursor measurements are configured in the "Cursors" dialog box which is opened via the "Cursor > Setup" menu or the "Cursor Results" box, or by pressing the CURSOR key.

7.1.3.1 Cursor Setup Tab

This tab contains general settings for cursor measurements. If you want to save the measurement results to a file, tap "Result export". See also: [chapter 11.2.2.4, "Numeric Results"](#), on page 381.

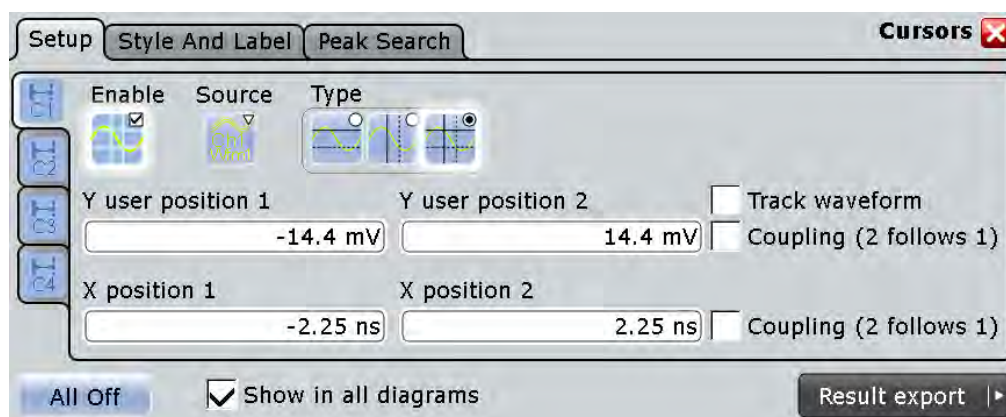

C1|C2|C3|C4

The settings for each cursor measurement (or cursor set) are configured on separate tabs. For each measurement, a horizontal pair of cursors, a vertical pair of cursors, or both can be displayed.

Enable

Enables the selected cursor measurement.

Remote command:

[CURSor<m>:STATe](#) on page 783

Source

Defines the source of the cursor measurement. Any of the input signal, math, reference or XY waveforms can be selected.

Remote command:

[CURSor<m>:SOURce](#) on page 784

Type

Defines the cursor type to be used for the measurement.

"Horizontal cursors"	The horizontal cursors are positioned automatically along the waveform or can be positioned manually.
"Vertical cursors"	The vertical cursors are positioned manually.
"Both horizontal and vertical cursors"	The horizontal cursors are positioned automatically along the waveform or can be positioned manually. The vertical cursors are positioned manually.

Remote command:

[CURSor<m>:FUNction](#) on page 783

Y user position 1|2

Defines the position of the horizontal cursor lines. The setting corresponds to the V1 and V2 values in the "Cursor Results" box.

If "Track waveform" is enabled, the user setting is disabled and the measurement results are displayed in the "Cursor Results" box.

Remote command:

[CURSor<m>:Y1Position](#) on page 785

[CURSor<m>:Y2Position](#) on page 785

Track waveform

The horizontal cursors track the waveform, i.e. one cursor line indicates the actual vertical maximum, and the second cursor line indicates the minimum. If the waveform changes, e.g. during a running measurement, the cursors move along with it. If both horizontal and vertical cursors are displayed, the horizontal cursors are positioned to the crossing points of the vertical cursors with the waveform. The measurement results are displayed in the "Cursor Results" box.

Tracking disables the Y-coupling (coupling horizontal cursor lines) and the Y user position settings.

Remote command:

[CURSor<m>:TRACking\[:STATe\]](#) on page 783

X position 1|2

Defines the position of the vertical cursors.

Remote command:

[CURSor<m>:X1Position](#) on page 784

[CURSor<m>:X2Position](#) on page 784

Coupling (2 follows 1)

Couples the horizontal and vertical cursor pairs so that the distance between the two lines remains the same if one cursor is moved.

Remote command:

[CURSor<m>:YCOupling](#) on page 785

[CURSor<m>:XCOupling](#) on page 784

Envelope wfm selection 1|2

This settings is available under the following conditions:

- The waveform arithmetic of the cursor source waveform is set to envelope waveform (see "[Wfm Arithmetic](#)" on page 112)
- Both horizontal and vertical cursors are enabled ("Type" = *Both*).
- "Track waveform" is enabled

The setting defines which horizontal cursor is positioned to the maximum and which to the the minimum envelope values.

"Minimum" The horizontal cursor is set to the crossing point of the vertical cursor with the minimum waveform envelope.

"Maximum" The horizontal cursor is set to the crossing point of the vertical cursor with the maximum waveform envelope.

Remote command:

[CURSor<m>:X1ENvelope](#) on page 786

[CURSor<m>:X2ENvelope](#) on page 786

All Off

Disables all cursor measurements at once.

Remote command:

[CURSor<m>:AOFF](#) on page 782

Show in all diagrams

Shows the enabled cursor measurements in all active diagrams of the same (time/spectrum) domain.

7.1.3.2 Cursor Style and Label Tab

The settings in this tab configure the display of the cursors.

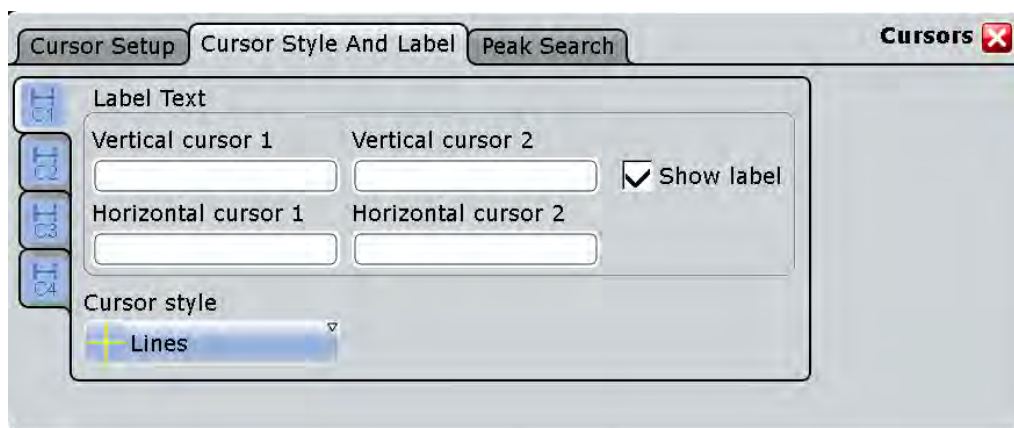

C1/C2/C3/C4

The settings for each cursor measurement (or cursor set) are configured on separate tabs. For each measurement, labels can be defined for the cursors. By default, the cursors are labeled as C1.1, C1.2, C2.1, C2.2, C3.1, C3.2, C4.1, C4.2.

Vertical cursor 1|2

Defines a label to be displayed with the vertical cursors.

Horizontal cursor 1|2

Defines a label to be displayed with the horizontal cursors.

Show label

Shows the cursor labels in the diagram.

Cursor style

Defines how the cursor is displayed in the diagram.

"Lines"	The cursors are displayed as lines.
"Line & Rhombus"	The cursors are displayed as lines. The intersections of the cursors with the waveforms are displayed by rhombus-shaped points.
"Rhombus"	The intersections of the cursors with the waveforms are displayed by rhombus-shaped points.

7.1.3.3 Peak Search Tab

The settings on this tab are only available in spectrum mode, i.e. the source of the cursor measurement is an FFT math waveform. In this case, the cursors can indicate the results of a peak search on the waveform. You can define which peaks the instrument will find by setting the "Peak excursion".

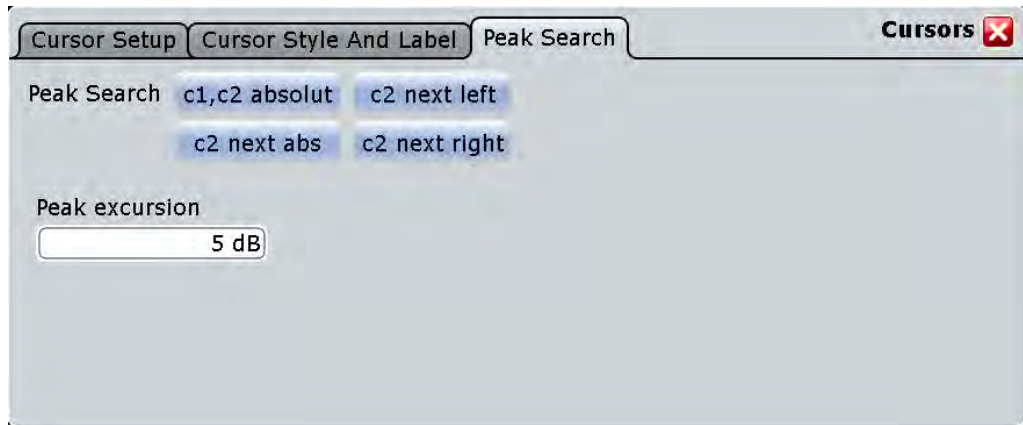

Peak excursion

The peak excursion defines when a peak is considered a peak during cursor measurements and peak searches. It defines a relative threshold, the minimum level value by which the waveform must rise or fall to be considered as a peak. To avoid identifying noise peaks, enter a peak excursion value that is higher than the noise levels.

This setting is only available for FFT waveforms. It is a global setting and is valid for both cursor measurements and peak search.

The following figure shows a cursor measurement on an FFT waveform:

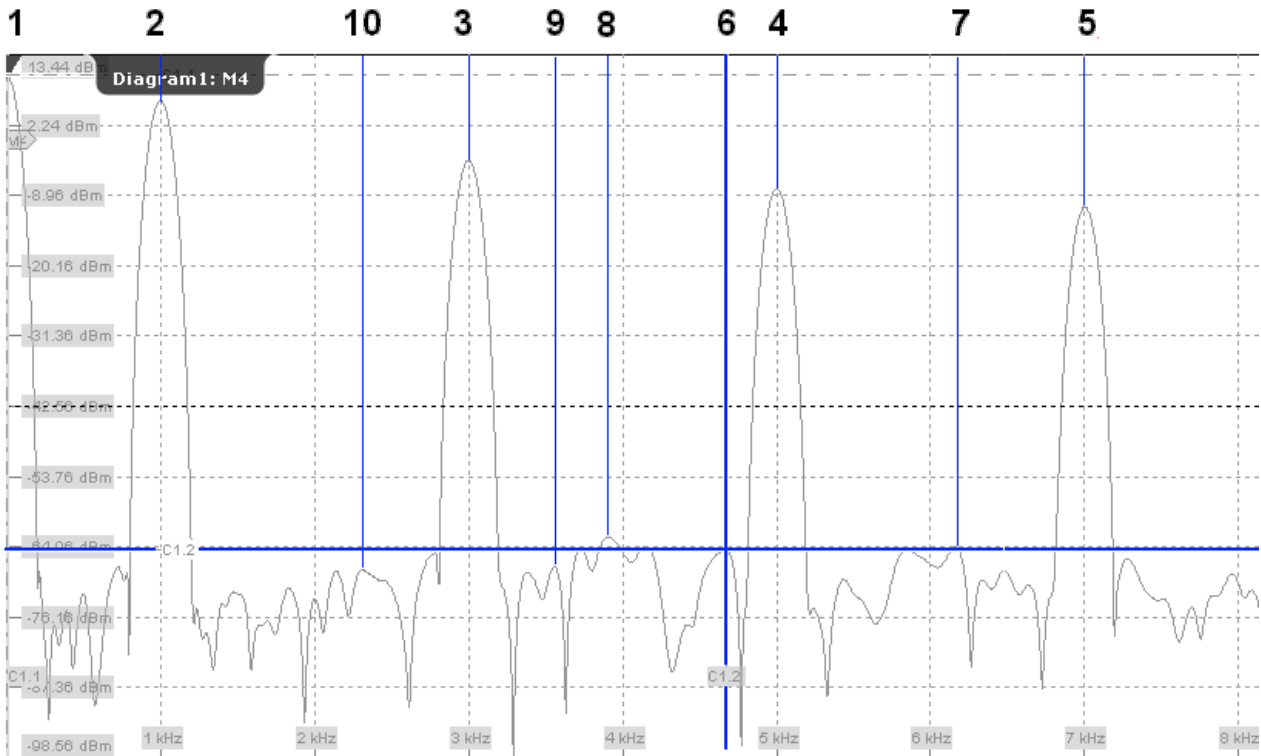

If "Peak excursion" is 30 dB, the peaks 1 to 5 are found. If "Peak excursion" is 20 dB, also the peaks 6 to 10 are found. The cursor position is on peak 6.

Remote command:

[CURSor<m>:PEXCursion](#) on page 789

c1, c2 absolute

Both cursors are set to the absolute peak value.

Remote command:

[CURSor<m>:MAXimum\[:PEAK\]](#) on page 788

c2 next abs

Cursor 2 is set to the next smaller absolute peak from the current position.

Remote command:

[CURSor<m>:MAXimum:NEXT](#) on page 788

c2 next right

Cursor 2 is set to the next peak to the right of the current position.

Remote command:

[CURSor<m>:MAXimum:RIGHT](#) on page 788

c2 next left

Cursor 2 is set to the next peak to the left of the current position.

Remote command:

[CURSor<m>:MAXimum:LEFT](#) on page 788

7.2 Automatic Measurements

- [Measurements, Measurement Types, and Results](#).....230
- [Reference Levels](#).....243
- [Performing Automatic Measurements](#).....252
- [Reference for Automatic Measurements](#).....261

7.2.1 Measurements, Measurement Types, and Results

The R&S RTO can perform up to eight measurements simultaneously. For each measurement, multiple measurement types are available to measure various characteristics of a source waveform.

Measurement types

Various measurement types are available, depending on the selected source.

Time domain

- Amplitude and time measurements
- Eye/Jitter measurements

- Histograms

Frequency domain

- Spectrum measurements
- Histograms

Default measurements

The default measurement starts when you tap the "Measurement" icon on the toolbar or press the MEAS key, and the measurement has not been configured before.

If a measurement has been set to another measurement type, the configured measurement is started by both the "Measurement" icon and the MEAS key. PRESET deletes any measurement configuration.

The default measurement depends on the type of the source waveform:

- Amplitude measurement for analog time domain waveforms
- Extinction ratio (%) for eye/jitter measurements
- Channel power measurement for frequency domain waveforms
- Waveform count for histograms
- Positive pulse measurement for digital channels (MSO option R&S RTO-B1)

See also: [chapter 7.2.3.1, "Starting an Automatic Measurement"](#), on page 253

Multiple measurements

For best performance, only one measurement is performed for each acquired waveform. However, you can enable multiple measurement, for example to measure the rise time for several cycles in one waveform. This is particularly useful when statistics are evaluated.

See also: ["Multiple measurement"](#) on page 278

Environment sensors

Environment sensors can provide additional information during a measurement, e.g. the temperature. The collected data can be displayed as a background color in the waveform diagram. Thus you can analyze, for example, temperature-dependant behavior during a measurement.

The various measurement types and results are described in detail in the following sections.

• Measurement Results	232
• Amplitude/Time Measurements	234
• Eye Diagram Measurements	238
• Histograms	240
• Spectrum Measurements	242
• Protocol Measurements	243

7.2.1.1 Measurement Results

The results of automatic measurements are displayed in result boxes on the screen. For each measurement, a separate result box is displayed. The result box is displayed automatically when an automatic measurement is enabled.

Similar to waveform diagrams, you can minimize the result box to a result icon on the signal bar, and display results in a separate diagram on the screen. For details, see "Displaying results" in the "Getting Started" manual.



If you want to save space in the display, minimize the result boxes. The most important results are displayed and updated in the signal icon, as well.





You can extend the result box with a small control panel which provides source settings and statistics enabling for quick access: "Measurements" dialog box > "Gate/Display" tab > "Show result control panel".

The function "Clear screen results" in the "Display" menu resets all results in all measurement result boxes including long term measurement and statistic results and deletes the current measurement waveforms.

Which results are displayed depends on the measurement type and is described in detail in the following chapters.

Status icons

Status information on the measurement is indicated by the following icons in the result box:

Icon	Description
	Measurement and limit checks: The measurement result might not be correct due to insufficient amplitude level. Check your amplitude and reference level settings.
	Limit check only: ok
	Limit check only: margin failed
	Limit check only: limit failed

Intermediate results

You can display auxiliary result lines and reference levels required to perform some measurement types (e.g. signal thresholds) in the source diagram.

Statistics

If statistics are enabled for the measurement, the following information is provided in the result box for each measurement type.

Label	Description
Current	Currently measured value
+Peak	Positive peak value (maximum)
-Peak	Negative peak value (minimum)
μ (Avg)	Average
RMS	Root mean square
σ (S-dev)	Standard deviation
Event count	Number of measured events (e.g. rising edges, pulses etc.)
Wave count	Number of waveforms (acquisitions) the measurement is based on

Stopping and starting the acquisition does not reset statistics but only stops and continues them.

The instrument only resets statistical evaluation if you change measurement setup:

- Measurement types
- Gate
- Enable/disable long term measurement and histogram
- Enable continuous autoscale with enabled histogram
- Switch on/off channels
- Enable/disable cursors
- Tap the "Reset" or "Clear results"

After a reset, new statistics are compiled beginning with the next acquired waveform.

Measurement histograms

Additionally, the results of compatible measurements can be displayed in a histogram which shows the density distribution of the measurement results in a graphic and thus illustrates the statistics of the measurements.

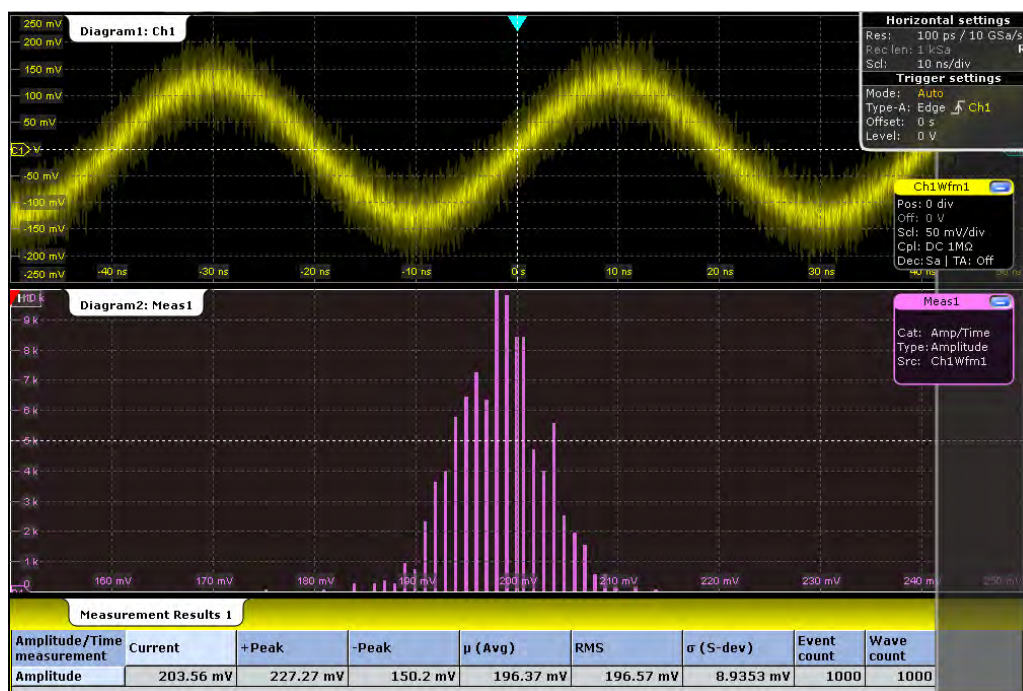

Fig. 7-1: Statistical results and measurement histogram of an amplitude measurement

Long term measurements

Long term measurements show the behavior of measurement results over a longer time or for a large number of samples. Therefore the measurement results of a specified time period is summarized into one long term point. For each point, the current value measured at the end of the time period is written to the long term waveform, and statistical results for each time period are calculated, saved, and reset. This reset avoids constantly rising maximum or constantly falling minimum values till the end of the measurement.

Long term measurements are performed on the main measurement. You can define the number of long term points and export the long term data, including statistical results. The measurement histogram is a vertical histogram shown in the long term diagram.

7.2.1.2 Amplitude/Time Measurements

The R&S RTO provides a variety of voltage, time, area and counting measurements in the "Measurements" dialog box, "Setup > Amp/Time" tab. All measurements can be used as main or additional measurement. Some measurements require reference levels to be set according to the measurement purpose.











The default measurement in the time domain is "Amplitude" for analog waveforms, or positive pulse measurement for digital channels (MSO option R&S RTO-B1).





- [Amplitude Measurements](#)..... 235
- [Time Measurements](#)..... 236
- [Area Measurements](#).....238
- [Counting](#).....238

Amplitude Measurements

Amplitude measurements are provided in the "Measurements" dialog box, "Setup > Amp/Time" tab.

Table 7-1: Amplitude measurements







	Meas. type	Symbol	Description/Result
	High	X_{High}	High signal level
	Low	X_{Low}	Low signal level
	Amplitude	X_{Ampl}	Amplitude of the signal: the difference of high and low signal levels $X_{Ampl} = X_{High} - X_{Low}$
	Max	X_{Max}	Absolute maximum value of the waveform
	Min	X_{Min}	Absolute minimum value of the waveform
	Peak to peak	X_{PkPk}	Peak-to-peak value of the waveform: the difference of maximum and minimum values $X_{Ampl} = X_{Max} - X_{Min}$
	Mean	X_{Mean}	Arithmetic average of the waveform voltage values $X_{Mean} = \frac{1}{N_{Eval}} \sum_{i=1}^{N_{Eval}} x(i)$
	RMS	X_{RMS}	RMS (Root Mean Square, quadratic mean) of the waveform voltage values $X_{RMS} = \sqrt{\frac{1}{N_{Eval}} \sum_{i=1}^{N_{Eval}} x^2(i)}$
	σ (S-dev)	σ_X	Standard deviation of the waveform samples $\sigma_X = \sqrt{\frac{1}{N_{Eval}-1} \sum_{i=1}^{N_{Eval}} (x(i) - X_{Mean})^2}$
	Pos. overshoot	R_{Pos}	Positive overshoot of a square wave, calculated from measurement values High, Max, and Amplitude $+Ovr = \frac{V_{top} - V_{P+}}{V_{Amp}} \cdot 100\%$
	Neg. overshoot	R_{Neg}	Negative overshoot of a square wave, calculated from measurement values Min, Low, and Amplitude $-Ovr = \frac{V_{base} - V_{P-}}{V_{Amp}} \cdot 100\%$









	Meas. type	Symbol	Description/Result
	Cycle mean		The mean value of one cycle
	Cycle RMS		The RMS (Root Mean Square) value of one cycle
	Cycle σ (S-dev)		The standard deviation of one cycle
	ProbeMeter		The DC voltage from the connected probe

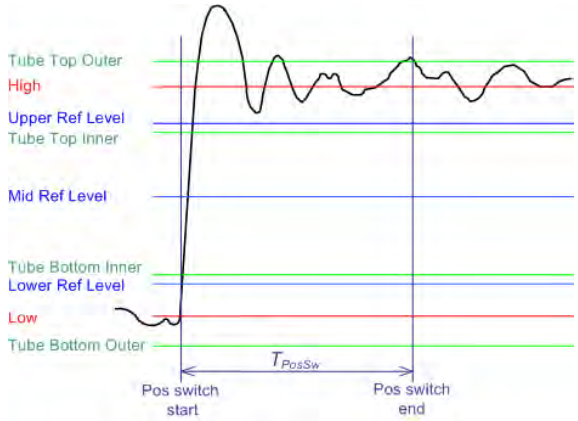

Time Measurements

Time measurements are provided in the "Measurements" dialog box, "Setup > Amp/Time" tab.

Table 7-2: Time measurement types

	Meas. type	Symbol	Description/Result
	Rise time	T_{Rise}	Rise time of the left-most rising edge of the waveform. This is the time it takes the signal to rise from the low reference level to the high reference level. Multiple measurement is possible.
	Fall time	T_{Fall}	Falling time of the left-most falling edge of the waveform. This is the time it takes the signal to fall from the high reference to the low reference. Multiple measurement is possible.
	Pos. pulse	$T_{PosPulse}$	Width of a positive pulse: time between a rising edge and the following falling edge measured on the middle reference level. The measurement requires at least one complete period of a triggered signal. Multiple measurement is possible.
	Neg. pulse	$T_{NegPulse}$	Width of a negative pulse: time between a falling edge and the following rising edge measured on the middle reference level. The measurement requires at least one complete period of a triggered signal. Multiple measurement is possible.
	Period	T_{Period}	Time of the left-most signal period of the waveform - the time difference between two consecutive waveform edges measured on the middle reference level. The measurement requires at least one complete period of a triggered signal. Multiple measurement is possible.
	Frequency	f_{Period}	Frequency of the signal, reciprocal value of the period. $f_{Period} = 1 / T_{Period}$
	Pos. duty cycle	R_{PosCyc}	Positive duty cycle: Width of a positive pulse in relation to the period in %. The measurement requires at least one complete period of a triggered signal. Multiple measurement is possible. $R_{PosCyc} = \frac{T_{PosPulse}}{T_{Period}} \cdot 100\%$



	Meas. type	Symbol	Description/Result
	Neg. duty cycle	R_{NegCyc}	Negative duty cycle: Width of a negative pulse in relation to the period in %. The measurement requires at least one complete period of a triggered signal. Multiple measurement is possible. $R_{NegCyc} = \frac{T_{NegPulse}}{T_{Period}} \cdot 100\%$
	Delay		Time difference between any two edges of two measurement sources at any reference level. The measurement result is negative if the edge of the second source comes before the edge of the first source. Slope and reference level have to be defined for each source. See: "Advanced Delay Setup" on page 266
	Phase		The phase difference between two waveforms ($delay / period * 360$)
	Burst width		The duration of one burst, measured from the first edge to the last
	Pos. switching	T_{PosSw}	Settling time at rising edges: Time between crossing the lower reference level and the last return of the signal into the top tolerance tube. See also: "Tube Tab" on page 251 
	Neg. switching	T_{NegSw}	Settling time at falling edges: Time between crossing the upper reference level and the last return of the signal into the bottom tolerance tube. See also "Pos. switching" above.
	Pulse train		Duration of N positive pulses, measured from the rising edge of the first pulse to the falling edge of the N-th pulse. N has to be configured.
	Setup Hold Setup/Hold time	T_{Setup} and T_{Hold}	Setup and Hold time measurement with positive and/or negative clock edge. See: "Setup/Hold measurement settings" on page 267

	Meas. type	Symbol	Description/Result
	Setup/Hold ratio	$T_{Setup} / (T_{Setup} + T_{Hold})$	Setup/Hold ratio measurement with positive and/or negative clock edge. See: " Setup/Hold measurement settings " on page 267
	Delay to trigger		Time between the trigger event and a following signal slope. High accuracy even if the trigger event is outside the acquisition data. See: <ul style="list-style-type: none"> "Delay to trigger measurement settings" on page 269 chapter 7.2.3.3, "Measuring the Delay to Trigger", on page 256

Area Measurements

Area measurements are voltage over time measurements. They are provided in the "Measurements" dialog box, "Setup > Amp/Time" tab.



Table 7-3: Area measurement types

	Meas. type	Symbol	Description/Result
	Area	A_{Ref}	Area between the waveform and a reference level ("Area level", X_{Ref}). $A_{Ref} = \frac{T_{Eval}}{N_{Eval}} \cdot \sum_{i=1}^{N_{Eval}} (x(i) - X_{Ref})$ T_{Eval} : Evaluation time, time of a full waveform or limited by a gate
	Cycle area	A_{RefCyc}	Area between the waveform and a reference level ("Area level") measured for one period, see also "Area" measurement. The measurement requires at least one complete period of a triggered signal. Multiple measurement is possible.

Counting

Counting measurements are provided in the "Measurements" dialog box, "Setup > Amp/Time" tab.

Table 7-4: Counting measurement types

	Meas. type	Symbol	Description/Result
	Pulse count		The number of positive or negative pulses of the waveform, or both. The mean value of the signal is determined. If the signal passes the mean value, an edge is counted. A positive pulse is counted if a rising edge and a following falling edge are detected. A negative pulse is counted if a falling edge and a following rising edge are detected.
	Edge count		The number of positive or negative edges, or of both. The instrument determines the mean value of the signal and counts an edge every time the signal passes the mean value.

7.2.1.3 Eye Diagram Measurements

The eye diagram is a superposition of repetitively sampled digital data. It is a tool for evaluation of signal quality and shows the combined effects of channel noise and inter-

symbol interference. The eye diagram is a significant means of visualizing jitter and allows you to analyze the reasons for it. By creating histograms of the eye diagram, important jitter parameters can be determined.



The waveform display style must be set to vectors: DISPLAY > "Signal Colors / Persistence" tab > "Style = Vectors"

To obtain optimized settings for an eye measurement, use the "Autoset" function that is provided on the right side of the "Eye" tab.

The following characteristic values can be determined:

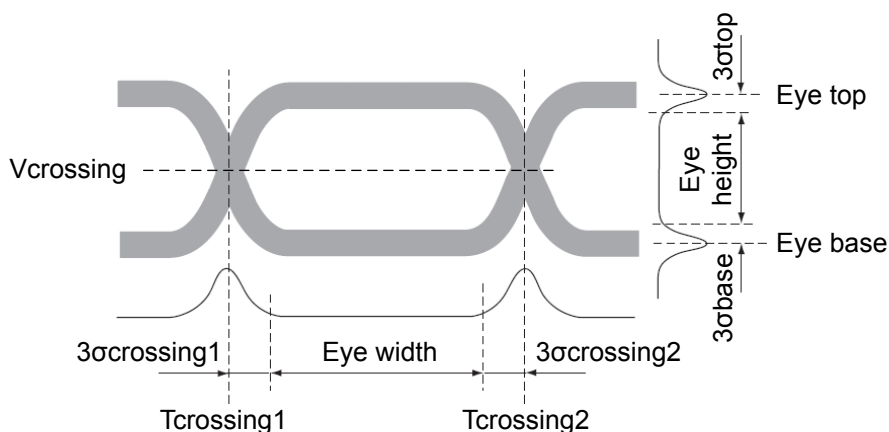

Fig. 7-2: Basic eye diagram characteristics

- Eye top = Mean of the upper vertical histogram
- σ_{top} = Standard deviation of the upper vertical histogram
- Eye base = Mean of the lower vertical histogram
- σ_{base} = Standard deviation of the lower vertical histogram
- Tcrossing = First and second mean of the horizontal histogram
- $\sigma_{crossing}$ = Standard deviation of the horizontal histogram

Table 7-5: Eye measurement types

Meas. type	Description/Result
Extinction ratio (%)	The extinction ratio is an indication of efficiency. It describes the ratio of the power used to transmit a logic level 1, to the energy used to transmit a logic level 0. The R&S RTO provides extinction ratio measurements as a percentage, and in decibels: $ER (\%) = Eye\ base / Eye\ top * 100$ Prerequisite: Eye base > 0 and Eye top > 0 because extinction ratio is defined only for positive values.
Extinction ratio (dB)	$ER (dB) = 10 * \log (Eye\ top / Eye\ base)$
Eye height	The vertical eye opening indicates the sensitivity of the transmission to noise. $(Eye\ top - 3 * \sigma_{top}) - (Eye\ base + 3 * \sigma_{base})$
Eye width	The horizontal eye opening indicates the time range during which the sampling of the logical state is possible. $(T_{crossing2} - 3 * \sigma_{crossing2}) - (T_{crossing1} - 3 * \sigma_{crossing1})$
Eye top	Mean of the upper vertical histogram

Meas. type	Description/Result
Eye base	Mean of the lower vertical histogram
Q factor	$Q \text{ factor} = (\text{Eye top} - \text{Eye base}) / (\sigma_{\text{top}} + \sigma_{\text{base}})$
Noise (RMS)	Quadratic mean of the noise of eye top and eye base
S/N ratio	Signal-to-noise ratio $\text{SNR} = 10 * \log (\text{Eye amplitude} / \text{Noise RMS})$
Duty cycle distortion	$\text{Duty cycle distortion} = 20 * \log (\text{Eye amplitude} / \text{Noise RMS})$
Eye rise time	Duration for signal to rise from 10% to 90% of the high signal level
Eye fall time	Duration for signal to fall from 90% to 10% of the high signal level
Eye bit rate	Frequency between two crossings
Eye amplitude	Eye top - Eye base
Jitter (peak to peak)	Average of the jitter for both crossing points. $\text{Jitter} = (\sigma_{\text{crossing1}} + \sigma_{\text{crossing2}}) / 2$
Jitter (6σ)	$\text{Jitter} (6\sigma) = \text{Jitter} * 6$
Jitter (RMS)	Quadratic mean of the jitter at both crossing points

The default eye measurement is extinction ratio (%).

7.2.1.4 Histograms

Histograms are used to plot density of data, i.e. to display graphically how often which signal values occur. In the R&S RTO, the histogram can be based on the input signal levels (amplitudes) or the time base in a time domain measurement, or on frequencies or frequency levels in a spectrum measurement.

Depending on which data the histogram is based on, a vertical or horizontal histogram can be selected. A vertical, or amplitude, histogram displays horizontal bars across amplitude values. A horizontal or time/frequency histogram displays vertical bars over time/frequencies.

You can define up to 8 histograms in a diagram, one of them is displayed. They can be created quickly with toolbar icons, or in the "Meas" menu >"Histogram" dialog box. To switch the histogram display, tap the required histogram area, or select it in the "Histogram" dialog box. For histogram measurements, the measured histogram is selected independently in the measurement setup.

In a histogram, the maximum count of a waveform value is assigned to the full height (histogram peak). All other count values are displayed relative to the maximum.

The following characteristic values can be determined for histograms (illustrated for a vertical histogram):

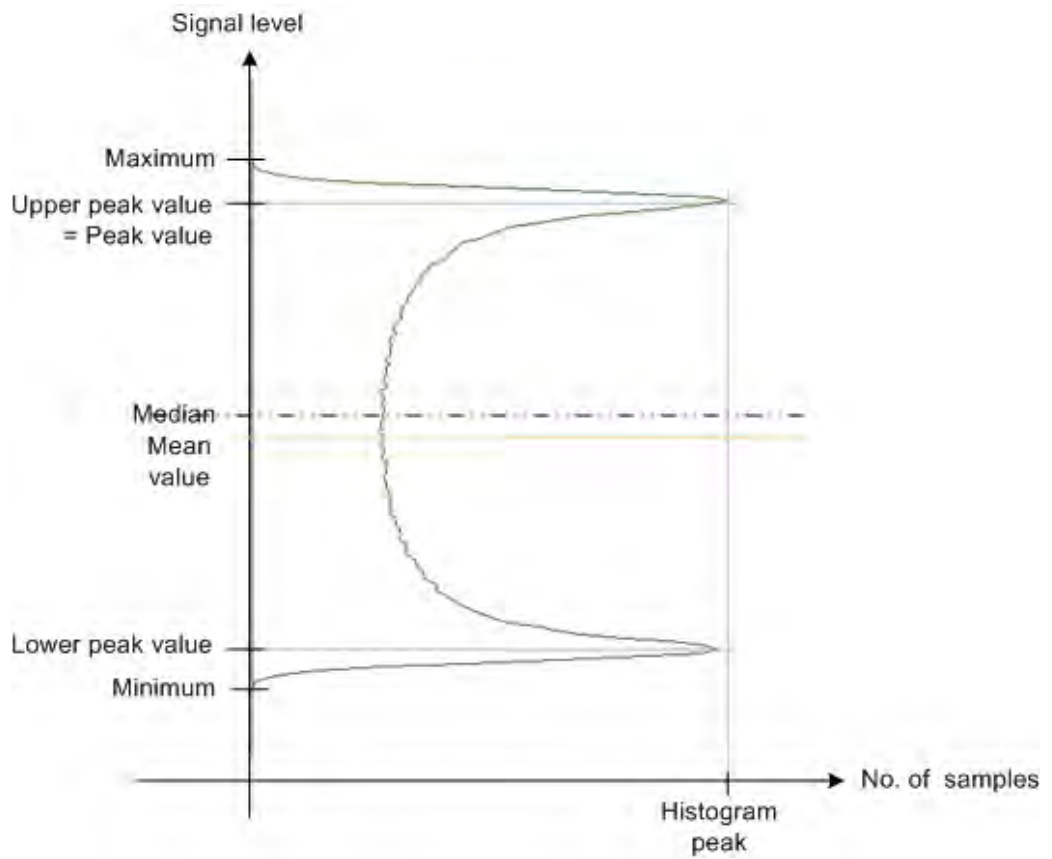

Table 7-6: Histogram measurement types

	Meas. type	Description/Result
1	Waveform count	The number of acquisitions (waveforms) the histogram is based on
2	Waveform samples	The number of samples from the most recent acquisition included in the current histogram
3	Histogram samples	The number of samples from all acquisitions included in the current histogram
4	Histogram peak	The maximum count value in the histogram
5	Peak value	The signal value at the histogram peak
6	Upper peak value	The signal value at the maximum count value in the upper half of the histogram
7	Lower peak value	The signal value at the maximum count value in the lower half of the histogram
8	Maximum	The highest signal value with a probability > 0
9	Minimum	The lowest signal value with a probability > 0
10	Median	The signal value for which half the samples lie above, the other half below in the histogram The sample count of one signal value after the other are accumulated until half the total number of samples in the histogram is reached. The signal value for which 50% of the samples are accumulated is the median.

	Meas. type	Description/Result
11	Max - Min	The range of signal values with a probability > 0
12	Mean	The weighted arithmetic average of the histogram
13	σ (S-dev)	Standard deviation of the sample numbers
14	Mean $\pm\sigma$	The range between (mean value + standard deviation) and (mean value - standard deviation)
15	Mean $\pm 2\sigma$	The range between (mean value + 3 * standard deviation) and (mean value - 2 * standard deviation)
16	Mean $\pm 3\sigma$	The range between (mean value + 3 * standard deviation) and (mean value - 2 * standard deviation)
17	Marker + Probability %	The marker value (according to the selected probability domain marker type) plus the defined limit. Note that the value is restricted to the histogram range.
18	Marker - Probability %	The marker value (according to the selected probability domain marker type) minus the defined limit. Note that the value is restricted to the histogram range.

See also: [chapter 7.2.3.4, "Creating a Histogram"](#), on page 256.



Rough jitter evaluation using a histogram

You can use a horizontal histogram to perform a rough jitter measurement. Define a histogram for a narrow amplitude range close to the trigger time. The "Max-Min" value indicates the peak jitter, while the "StdDev" value indicates the RMS jitter.

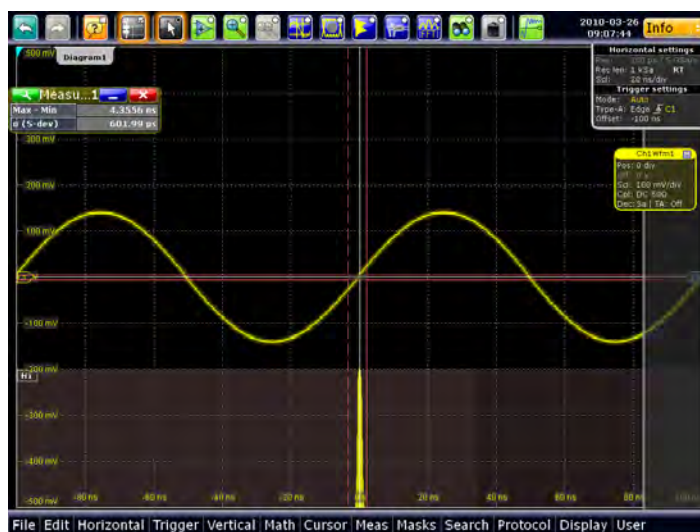

7.2.1.5 Spectrum Measurements

Spectrum analysis determines the frequencies of a given input signal over time. Various measurements can then be performed based on the signal spectrum.

The default measurement on a spectrum is a "Channel Power" measurement, which provides the integrated power over the sample values as a result.

Table 7-7: Spectrum measurement types

	Meas. type	Description/Result
1	Channel power	Power integrated over the sample values defined by a center frequency and a bandwidth; based on a defined impedance; the result is given in mW
2	Occupied bandwidth	From the defined center frequency, symmetric sample value pairs to the left and right are integrated until a user-defined percentage of the total power is reached; the occupied bandwidth is the difference between the frequencies at which the requested power was reached
3	Bandwidth	n dB down Bandwidth; the samples to the left and right of the peak value are analyzed until the n dB threshold is exceeded; the frequencies at which the threshold is exceeded define the limits of the requested bandwidth
4	Total harmonic distortion	Power sum of the harmonic waves divided by the power of the fundamental wave: $THD = \frac{\sum_{n=2}^{\infty} P_n}{P_1}$

7.2.1.6 Protocol Measurements

Measurements on serial buses are available for audio signals (option R&S RTO-K5). The results of these measurements are track and trend waveforms which are described in [chapter 14.8.5, "Track and Trend"](#), on page 502.

7.2.2 Reference Levels

Some measurement types require reference levels to obtain the the measurement points, e.g. rise time/fall time measurement or pulse count. Reference levels are referred to the signals, for each waveform you can define specific reference levels. Thus, for all measurements on a waveform the same reference levels are used.

Reference and signal levels are determined automatically. However, for irregular data it may be useful to configure them manually, or to define some parameters for automatic determination.

In addition to reference and signal levels you can define hystereses for reference levels, as well as tubes for signal levels. Hystereses are useful for measurements that determine zero-crossings. Tubes define evaluation ranges for measurements that require high level or low level detection. If the signal value remains within the defined tubes, it is considered to be high or low.

Reference levels and intermediate results required for further measurements can be displayed in the source diagram.

Example:

Data signals may contain intervals where no data is transmitted, so that a high and low state can not be determined for each acquisition. In this case, you can define the high and low signal levels manually, in order to evaluate other measurement results.

Furthermore, if the signal levels vary strongly or have large overshoots, the rise and fall levels may be difficult to determine.

Finally, if fixed levels are defined for the DUT, you can configure the reference levels in the R&S RTO correspondingly and analyze the resulting measurement data.

7.2.2.1 Configuring Reference Levels

To determine reference and signal levels automatically

By default, the histogram of the measurement data is evaluated to determine the required levels automatically. However, you can define several parameters to adapt the evaluation to your data.

1. From the "Meas" menu, select "Reference Level > Levels" to open the "Measurement" dialog box.
2. Select the "Levels" tab.
3. Define the "Source" from which the reference is taken. The source can be any signal input, math or reference waveform.
4. Select automatic "Reference level mode".
5. Define which signal level is used as a reference. For details see ["Signal level mode"](#) on page 247.
6. By default, the lower reference level is defined at 10% of the selected signal level, the middle reference level at 50% and the upper reference level at 90%. Optionally, select other "Relative levels" to be used for evaluation.
7. To determine the reference levels using average values from several histograms, enable the "Histogram averaging" option and define an "Average Count" to define how many histograms are averaged.
Averaging is not available if "Absolute peaks" are selected as the "Signal level mode".
8. To define a hysteresis for the middle reference level, select the "Hysteresis" tab and enter a percentage of the selected signal level.
A rise or fall from the middle reference value that does not exceed the hysteresis is rejected and not considered a zero-crossing.
9. To define a tube for the high and low signal levels:
 - a) Select the "Tube" tab.
 - b) In the "Relative outer" field, define a percentage of the signal level by which the absolute signal level may be larger than high signal level or lower than the low signal level to be considered high or low, respectively.

- c) In the "Relative inner" field, define a percentage of the signal level by which the absolute signal level may be higher than the low signal level or lower than the high signal level to be considered low or high, respectively.

To determine reference and signal levels manually

You can configure the reference levels manually as fixed absolute or relative values.

1. From the "Meas" menu, select "Reference Level > Levels" to open the "Measurement" dialog box.
2. Select the "Levels" tab.
3. Define the "Source" from which the reference is taken. The source can be any signal input, math or reference waveform.
4. Select manual "Reference level mode".
5. Under "Level definition", select whether you want to define the levels using absolute or relative values.
6. Under "User level selection", select whether you want to configure the high and low signal levels ("User signal level") or the lower, middle and upper reference levels ("User reference level").
7. To define high and low signal levels:
 - a) Enter the absolute high and low signal levels.
 - b) By default, the lower reference level is defined at 10% of the selected signal level, the middle reference level at 50% and the upper reference level at 90%. Optionally, select other "Relative levels", or define absolute "Top distance" and "Bottom distance" values to be used for evaluation.
8. To define lower, middle and upper reference levels:
 - a) Enter the absolute upper and lower reference levels.
 - b) By default, the lower reference level is defined at 10% of the selected signal level, the middle reference level at 50% and the upper reference level at 90%. Optionally, select other "Relative levels", or define absolute "Top distance" and "Bottom distance" values to be used for evaluation of the high and low signal levels.
9. To define a hysteresis for the middle reference level, select the "Hysteresis" tab and enter a percentage of the selected signal level.

A rise or fall from the middle reference value that does not exceed the hysteresis is rejected and not considered a zero-crossing.
10. To define a tube for the high and low signal levels:
 - a) Select the "Tube" tab.

- b) For relative value definition:
 - In the "Relative outer" field, define a percentage of the signal level by which the absolute signal level may be larger than the high signal level or lower than the low signal level to be considered high or low, respectively.
 - In the "Relative inner" field, define a percentage of the signal level by which the absolute signal level may be higher than the low signal level or lower than the high signal level to be considered low or high, respectively.
- c) For absolute value definition:
 - In the "Top outer" field, define an area above the high signal level which is still considered to be high level.
 - In the "Top inner" field, define an area beneath the high signal level which is still considered to be high level.
 - In the "Bottom inner" field, define an area above the low signal level which is still considered to be low level.
 - In the "Bottom outer" field, define an area beneath the low signal level which is still considered to be low level.

To display reference levels and intermediate results

1. From the "Meas" menu, select "Setup" to open the "Measurement" dialog box.
2. Select the tab for the measurement you want to configure.
3. Select the "Gate/Display" tab.
4. Enable the "Display result lines" or "Display reference levels" option, or both.

The reference levels and intermediate results required for further measurements are displayed in the source diagram.

7.2.2.2 Reference Level Settings

Some measurements refer to specific reference or signal levels, e.g. rise time/fall time, counting pulses. Generally, these settings are determined automatically. However, for irregular data it may be useful to configure them manually. You can define reference and signal levels, as well as hystereses for reference levels and tubes for signal levels.

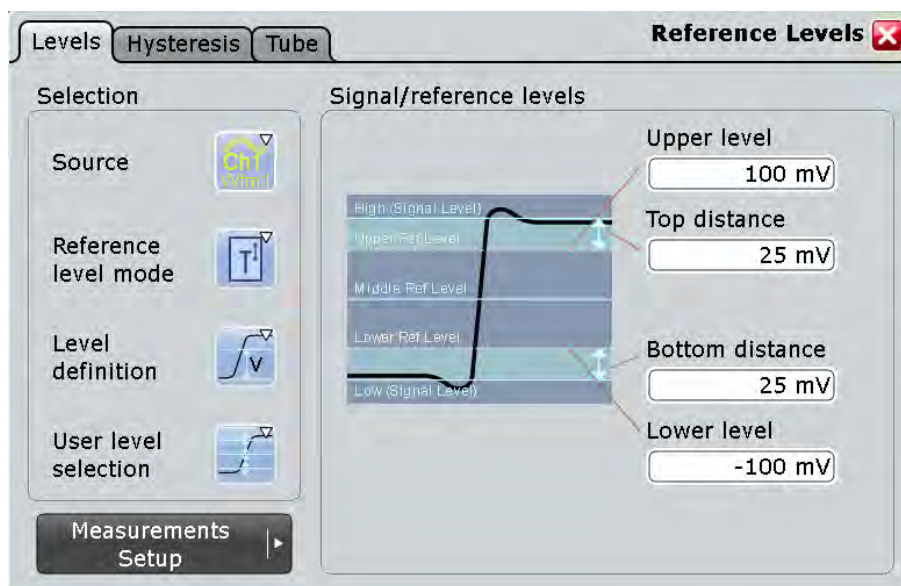

Selection Settings

The general settings in the "Selection" area are the same for all tabs in the "Reference" dialog box.

Source

Defines the source from which the reference is taken. The source can be any signal input, math or reference waveform.

Remote command:

Source is defined by suffix <m> in "REFLevel" subsystem, see [chapter 21.2.11.2, "Reference Level"](#), on page 796

Reference level mode

Defines whether the reference level is configured manually or automatically.

Remote command:

[REFLevel<m>:LDETection](#) on page 797

Signal level mode

In automatic reference level mode, the setting defines the high and low signal levels from which the reference levels are derived. The instrument analyzes the signal and performs amplitude and histogram measurements to define the signal level.

See also: [chapter 7.2.1.4, "Histograms"](#), on page 240

"Auto select absolute probability"	The most suitable signal levels for the selected measurement are used.
"Peak probability"	The signal levels with the highest probability values are used. These are the upper peak value and the lower peak value of the histogram measurement.
"Mean probability"	The signal levels with mean probabilities are used.

"Absolute peak"	The absolute peak signal levels are used. These are the maximum and minimum signal values of the amplitude measurement.
"Upper absolute peak - Lower mean probability"	The high signal level is the upper absolute peak (the maximum signal level), and the low signal level is the level with the mean probability in the lower half of the histogram.
"Upper mean probability - Lower absolute peak"	The high signal level is the level with mean probability in the upper half of the histogram, and the low signal level is the lower absolute peak (the minimum signal level).
Upper absolute peak - Lower manual	The high signal level is the maximum result value of the amplitude measurement. The low signal level is manually set using "Low".

Remote command:

[REFLevel<m>:AUTO:MODE](#) on page 799

Level definition

In manual reference level mode, the setting defines whether the reference is configured using absolute or relative values.

Remote command:

[REFLevel<m>:LMODE](#) on page 799

User level selection

In manual reference level mode, the setting defines whether the user-defined signal levels or user-defined reference levels are used for the measurements.

"User signal level" The high and low signal levels are defined by the user.

"User reference level" The reference levels are defined by the user.

Remote command:

[REFLevel<m>:USRLevel](#) on page 798

Levels Tab

The settings in this tab configure reference and signal levels. . In automatic reference level mode, the reference levels are always relative values. In manual reference level mode, relative and absolute "Level definitions" are possible.

For a description of "Selection" settings, see ["Selection Settings"](#) on page 247.

Relative levels

The lower, middle and upper reference levels, defined as percentages of the high signal level.

Available relative levels:

- 5/50/95
- 10/50/90
- 20/50/80
- User defined: Enter "Upper ref level", "Middle ref level", and "Lower ref level".

For example, for "5/50/95":

- lower reference level = 5% of high signal level
- middle reference level = 50% of high signal level
- upper reference level = 95% of high signal level

Remote command:

[REFLevel<m>:RELative:MODE](#) on page 797

Upper ref level, Middle ref level, Lower ref level

Define any reference levels in percent, if "Relative levels" is set to "User-defined".

Remote command:

[REFLevel<m>:RELative:UPPer](#) on page 805

[REFLevel<m>:RELative:MIDDLE](#) on page 805

[REFLevel<m>:RELative:LOWer](#) on page 806

High

The signal value that represents a high level - for manual reference level mode, absolute level definition and user signal level.

Remote command:

[REFLevel<m>:ABSolute:HIGH](#) on page 801

[MEASurement<m>:REFLevel:RESult:SIGHigh?](#) on page 809

Low

The signal value that represents a low level - for manual reference level mode, absolute level definition and user signal level.

Remote command:

[REFLevel<m>:ABSolute:LOW](#) on page 802

[MEASurement<m>:REFLevel:RESult:SIGLow?](#) on page 809

Top distance

The distance between the high signal level and the upper reference level - for manual reference level mode and absolute level definition.

Remote command:

[REFLevel<m>:ABSolute:TDIStance](#) on page 802

Bottom distance

The distance between the lower reference level and the low signal value - for manual reference level mode and absolute level definition.

Remote command:

[REFLevel<m>:ABSolute:BDIStance](#) on page 803

Upper level

The upper reference level, required e.g. to determine a rise - for manual reference level mode, absolute level definition and user reference level.

Remote command:

[REFLevel<m>:ABSolute:ULEVel](#) on page 803

[MEASurement<m>:REFLevel:RESult:UPPer?](#) on page 809

Lower level

The lower reference level, required e.g. to determine a fall - for manual reference level mode, absolute level definition and user reference level.

Remote command:

`REFLevel<m>:ABSolute:LLEVel` on page 804

`MEASurement<m>:REFLevel:RESult:LOWer?` on page 809

Histogram averaging

Enables averaging over several histograms to determine the reference levels.

This function is only available in automatic reference level mode.

Remote command:

`REFLevel<m>:AUTO[:STATe]` on page 800

Average Count

Defines the number of histograms to calculate the average from.

This function is only available in automatic reference level mode.

Remote command:

`REFLevel<m>:AUTO:COUNT` on page 801

Hysteresis Tab

This tab allows you to define a hysteresis for measurements that determine zero-crossings.

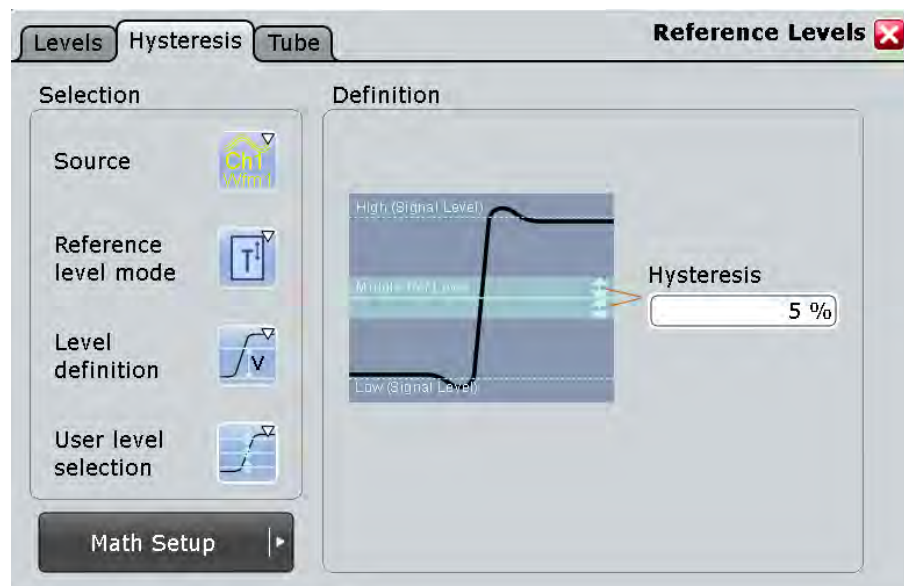

For a description of "Selection" settings, see ["Selection Settings"](#) on page 247.

Hysteresis

Defines a hysteresis for the middle reference level. A rise or fall from the middle reference value that does not exceed the hysteresis is rejected as noise.

Remote command:

[REFLevel<m>:RELative:HYSTeresis](#) on page 806

Tube Tab

This tab allows you to define evaluation tubes for measurements that require high level or low level detection. If the signal value remains within the defined tubes, it is considered to be high or low.

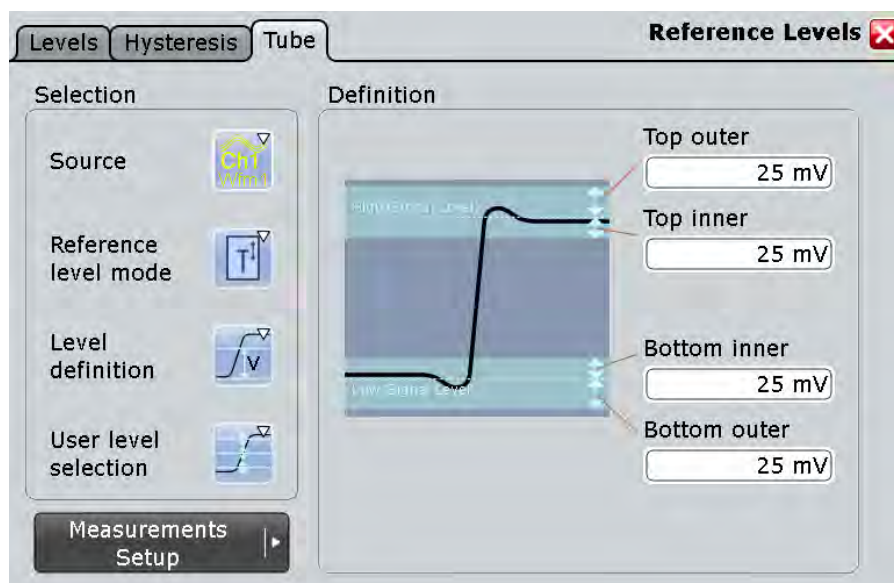

For a description of "Selection" settings, see ["Selection Settings"](#) on page 247.

Top outer

Defines an area above the high signal level which is still considered to be high level.

Remote command:

[REFLevel<m>:ABSolute:TOTube](#) on page 807

[MEASurement<m>:REFLevel:RESult:TOUTer?](#) on page 810

Top inner

Defines an area beneath the high signal level which is still considered to be high level.

Remote command:

[REFLevel<m>:ABSolute:TITube](#) on page 808

[MEASurement<m>:REFLevel:RESult:TINNER?](#) on page 810

Bottom inner

Defines an area above the low signal level which is still considered to be low level.

Remote command:

[REFLevel<m>:ABSolute:BITube](#) on page 808

[MEASurement<m>:REFLevel:RESult:BINNer?](#) on page 809

Bottom outer

Defines an area beneath the low signal level which is still considered to be low level.

Remote command:

[REFLevel<m>:ABSolute:BOTube](#) on page 808

[MEASurement<m>:REFLevel:RESult:BOUter?](#) on page 810

Relative outer

Defines a percentage of the signal level by which the absolute signal level may be larger than the high signal level or lower than the low signal level to be considered high or low, respectively.

Remote command:

[REFLevel<m>:RELative:OTUBe](#) on page 807

Relative inner

Defines a percentage of the signal level by which the absolute signal level may be higher than the low signal level or lower than the high signal level to be considered low or high, respectively.

Remote command:

[REFLevel<m>:RELative:ITUBe](#) on page 807

7.2.3 Performing Automatic Measurements

Automatic measurements are started simply by tapping the "Measurement" icon on the toolbar or by pressing the MEAS key. In order to configure more complex or additional measurement types, setup dialog boxes are available.

Up to eight automatic measurements can be configured and performed simultaneously with the data acquisition; the results are displayed in a result box.



From the result box, the settings dialog box can be opened using the  icon.

The measurement results can be displayed in a result box, in a minimized result icon on the signal bar, or as table in a separate diagram area. For details, see "Displaying results" in the "Getting Started" manual.

The results of an optionally connected environment sensor can also be taken into consideration in the results display of the measurement.

To display measurement information in the diagram

You can display auxiliary lines in the source waveform to determine how a measurement result was obtained. Such lines include gate areas, reference levels or intermediate result lines, such as the signal thresholds for rise and fall time measurements.

1. From the "Meas" menu, select "Setup", or press the MEAS key to open the "Measurement" dialog box.
2. Select the "Gate/Display" tab.

3. Select the tab for the measurement you want to configure.
4. To display an active gate area, select "Show gate".
5. To display intermediate result lines, select "Display result lines".
6. To display reference levels, select "Display reference levels".

To clear the measurement results

1. On the "Display" menu, tap "Clear screen results".
The results of all measurements are cleared.
2. To restart measurement statistics, select "Reset now" in the "Measurement Results" box.
The results in the selected measurement result box are cleared.
3. Alternatively, proceed as follows:
 - a) Press the MEAS key to open the "Measurement" dialog box.
 - b) Select the "Gate/Display" tab.
 - c) Select the tab for the measurement you want to clear.
 - d) Tap "Clear Results".The results in the selected measurement result box are cleared.

7.2.3.1 Starting an Automatic Measurement

There are three methods to start an automatic measurement, each with slightly different effects:

- Using the "Measurement" icon on the toolbar:



The icon starts the measurement with the lowest number. If this measurement has not been configured before, the default measurement for the selected waveform is started.

If you drag a rectangle on the screen, this rectangle defines the measurement gate.

See: ["To start a measurement using the toolbar icon"](#) on page 254.

- Pressing MEAS key on the front panel.
Of no measurement is running, the key works in the same way as the toolbar icon. A gate has to be configured in the dialog box.
If a measurement is already running, the key opens the "Measurement" dialog box for the currently selected measurement.
See: ["To start a measurement with the MEAS key"](#) on page 254.
- Tap "Meas" menu > "Setup", configure the measurement and enable "State" in the "Measurement" dialog box.
The configured measurement is started and the result box is displayed.
See: [chapter 7.2.3.2, "Configuring Measurements"](#), on page 254.

To start a measurement using the toolbar icon

1. Select the waveform for which you want to perform the measurement.
2. Tap the "Measurement" icon on the toolbar.



3. Define the measurement range in one of these ways:
 - Tap the diagram with the selected waveform.
 - Draw a rectangle on the screen to define a gate area that limits the measurement.

The configured measurement or the default measurement is enabled for the next available measurement configuration. The "Measurements" result box is displayed.

To start a measurement with the MEAS key

1. Select the waveform on the screen.
2. Press the MEAS key.

The configured measurement or the default measurement is enabled for the next available measurement configuration, using the selected waveform as the source. The "Measurements" result box is displayed.

7.2.3.2 Configuring Measurements

Up to eight automatic measurements can be configured and performed simultaneously with the data acquisition.

Spectrum measurements require an FFT math waveform as measurement source. Histogram measurements require a histogram as source.

1. If a measurement was already started with the toolbar icon or MEAS key, tap the  icon in the result box, or press the MEAS key to display the "Measurements" dialog box. Otherwise, tap the "Meas" menu and select "Setup".
2. Select the vertical tab for the measurement you want to configure.
3. Tap "Source" and select the waveform to be used as the measurement source. For histogram measurements, select the histogram. If you enabled the measurement with the toolbar icon or MEAS key, the source is already defined. However, you can select any other input channel, math or reference waveform.
4. On the "Setup" tab, select the measurement category tab: "Amp/Time", "Eye/Jitter", "Spectrum", or "Hist".

5. Under "Main measurement", select the main measurement type. This measurement is the one referred to if the measurement result is used as a source for math calculations.
For details on the available measurement types, see .
6. Optionally, tap "Activate" to select further measurement types.
All active measurement types are displayed in the measurement overview. Here you can enable or disable the measurement types individually or all at once, except for the main measurement type.
7. Depending on the selected measurement type, further settings may be required:
 - For phase and delay measurements, tap "2nd Source" and select a second waveform.
 - For area measurements, set the "Area level". By default, the time axis is used.
 - For eye measurements, tap "Autoset" to define optimized settings for the eye measurement.
 - For "Bandwidth" measurements, enter the "N db down" value, i.e. the threshold until which the samples to the left and right of the peak value are analyzed.
 - For "Channel Power" measurements, enter the "Channel BW" over which the channel power is calculated, and the "Channel CF", the center frequency from which the channel power is calculated.
 - For "Occupied Bandwidth" measurements, enter the percentage of the total power used to determine the occupied bandwidth in the "Occup. BW" field.
 - For histogram measurement types "Marker + Probability %" or "Marker - Probability %", define the marker "Reference" for the probability domain. Then define the "Delta" in percent which is to be added or subtracted from the marker value.
8. Depending on the selected measurement type, further optional settings may be available:
 - For all Amp/Time measurements, you can optionally define a "Signal threshold" to exclude signal values from the measurement if they do not exceed this threshold .
 - For all Amp/Time measurements performed on waveforms with waveform arithmetic mode "Envelope" or with "Peak detect" decimation, you can select the upper or lower part of the waveform for measurement, or a combination of both with "Envelope selection".
 - For all spectrum measurements, you can optionally define a "Noise reject" threshold.
9. Optionally, define a gate area to restrict the measurement to an extract of the waveform, as described in [chapter 7.2.3.6, "Using Gate Areas"](#), on page 258.
If you enabled the measurement with the toolbar icon and drew a rectangle on the diagram, the gate area is automatically defined and enabled.
10. To compile and display statistics for the measurement, select "Statistics".
11. Optionally, perform a limit check as described in [chapter 7.2.3.5, "Performing Limit Checks"](#), on page 257.

12. Tap "State" to enable the measurement.

The results of the measurement are displayed in the result box.

7.2.3.3 Measuring the Delay to Trigger

Delay to trigger measures the time between the trigger point and the following slope of a waveform. If the delay is completely unknown, it can be measured in two stages - first a coarse and then a precise measurement.

See also: "[Delay to trigger measurement settings](#)" on page 269

1. Set the horizontal scale and horizontal position so that the trigger point and the slope both are visible on the screen.
2. Configure the delay to trigger measurement:
 - a) On the "Measurements Setup" tab, select "Delay to trigger" as main or additional measurement.
 - b) Select the source, that is the waveform with the delayed slope to be measured.
 - c) Select the slope, and the reference level
 - d) Check the trigger settings.
 - e) Enable the measurement and note the result.

3. Turn the horizontal POSITION knob and enter the measured delay as horizontal position.

Thus, the slope is moved to the center of the screen.

4. Adjust the horizontal scale and the horizontal resolution parameters (RES / REC LEN) to the required accuracy: "Sample rate", "Resolution", or "Acquisition time".

The trigger is outside the display and is not part of the current acquisition.

5. Repeat the "Delay to trigger" measurement.

Now the delay is measured with high accuracy. You can analyze the variance of delay values using statistical evaluation and histogram functions.

7.2.3.4 Creating a Histogram

Histograms can be used to evaluate the sample value occurrences directly. They are a prerequisite for histogram measurements.

See also: [chapter 7.2.1.4, "Histograms"](#), on page 240.

To create a histogram quickly with toolbar icons

1. Select the waveform for which you need a histogram.
2. Tap either the "Vertical histogram" or the "Horizontal histogram" icon on the toolbar.



Note: The "Horizontal histogram" icon has to be activated in the toolbar configuration: "Display" menu > "Toolbar"

3. Tap the diagram with the waveform to be measured, or draw a rectangle on the screen to define the area on which the histogram is to be based.

The histogram range is indicated in the diagram and a histogram with the selected waveform as a source is defined and displayed.

To create and configure a histogram in the dialog box

1. Select "Meas > Histogram", or touch and hold an existing histogram or histogram area.

The "Histogram Setup" dialog box is displayed.

2. If no histogram was defined yet, tap the "Add" icon in the upper right corner of the dialog box to create a new tab for histogram configuration.



To copy an existing histogram and configure a new one based on those settings, tap the "Copy" icon.



3. To change the name of a histogram, double-tap the tab label and enter a name for the histogram using the on-screen keyboard.
4. Select a "Source" for the histogram. The source can be any input signal, math or reference waveform.
5. Define the histogram "Mode": vertical for an amplitude, horizontal for a time-based histogram.
6. Define the range of the waveform for which the histogram is to be generated. Enter the start and stop values in x and in y direction, either as absolute or relative values.

7.2.3.5 Performing Limit Checks

Limit checks allow you to analyze the measured values. If the defined limits are exceeded, specific actions can be initiated. Margins are not as strict as limits and belong to the valid value range, but can also initiate certain actions. Limit checks are available for all automatic measurement types.

To perform a limit check

1. From the "Meas" menu, select "Setup" to open the "Measurement" dialog box.
2. Select the tab for the measurement you want to configure.

3. Under "Limit check", select "Limit only" to distinguish only between valid and non-valid values, or "Margin&Limit" to perform a two-level value check, where the margin is still valid, the limit is not.
4. In the measurement overview, define the upper and lower limits and, if selected, margins for each active measurement type to be checked.
5. In the measurement overview, define the valid value range for each active measurement type to be checked. Note that the margins must always be within the valid value range. If necessary, the limit or margin values are adapted to match the selected valid range.
For details on the value range definitions see ["Limit check"](#) on page 263.
6. Define what happens when the limits and margins defined for a measurement type are exceeded.
 - a) Select the "Event Actions" tab.
 - b) For each action, define whether it is to be initiated:
 - if the limits or margins are exceeded
 - if the measurement is completed without limit violations
 - not at all
 - c) If "E-mail" is selected, define a recipient address under "E-mail setup".
If "Save Wfm" is selected, define a storage location under "Waveform destination".
If "Print" is selected, configure the print settings as described in [chapter 11.1.1, "Configuring Printer Output and Printing"](#), on page 360.

As a result of the limit check, the specified actions are performed and the status is indicated by an icon in the result box (see [chapter 7.2.1, "Measurements, Measurement Types, and Results"](#), on page 230).

7.2.3.6 Using Gate Areas

Gate areas limit the measurement to a user-defined range of the waveform.

For basic amplitude vs. time or channel power measurements the gate area can be defined directly after selecting the corresponding toolbar icon. For all other measurements, or if you want to define a more precise gate area, configuration is done in the "Measurement > Gate/Display" dialog box.

1. On the "Meas" menu, tap "Gate/Display".
2. Select the tab for the measurement you want to configure.
3. To define the gate, use one of the following methods:
 - Define the start and stop values of the gate area by entering either absolute or relative values.
 - If a zoom area has already been defined for the waveform, couple the gate area to the zoom area by selecting the "Zoom coupling" option.
 - If a cursor measurement has already been defined for the waveform, couple the gate area to the cursor lines by selecting the "Cursor coupling" option.

4. Tap the "Use gate" icon to enable the gate area usage.
5. Optionally, tap the "Show gate" icon to indicate the gate area in the diagram.

The measurement is performed on the selected value range of the waveform. If selected, the used range is indicated in the diagram.

7.2.3.7 Performing Long-term Measurements

In order to evaluate time-dependant behavior of a measurement, you can perform the measurement over a long period of time or for a large number of samples.

See also:

- ["Long term measurements"](#) on page 234
 - [chapter 7.2.4.9, "Measurements - Long Term/Track"](#), on page 278
1. From the "Meas" menu, select "Long Term/Track".
 2. Select the tab for the measurement you want to configure.
 3. Under "Long term", tap "Enable".
 4. Since the waveform may change in the process of time, enable "Continuous auto scale" to have the scaling adapted automatically.
Alternatively, tap the "Auto scale" to adjust the scale once and to see the long term waveform.
 5. Tap "Horizontal scaling".
 6. Define the "Number of points" to be shown in the long term diagram.
 7. Set the "Scale mode" that defines the period of time from which one long term point is created.
See ["Scale mode"](#) on page 281 for setting details.
For each long term measurement point, the current measurement value is added to the long term waveform.
 8. If you need the statistical data of the long term points:
 - a) Tap "Long Term/Track" to return to the measurement settings.
 - b) Enable statistics.
 - c) Let the measurement run and export the data when finished, see [chapter 11.2.2.5, "Long Term / Meas Histograms"](#), on page 382.

7.2.3.8 Compiling Measurement Statistics

Statistics can be compiled for all measurement types, and also for long-term measurements. If enabled, statistics for the measurement are included in the result box, see [chapter 7.2.1, "Measurements, Measurement Types, and Results"](#), on page 230.

In order to obtain meaningful results, it may be useful to configure specific measurement settings:

- "Multiple measurement" on the "Gate/Display" tab: the measurement result is not only determined once within one acquisition, but repeatedly, if available; this provides a larger basis for statistical evaluation
- Reference/signal levels: configuring user-defined levels may compensate for irregular data, see [chapter 7.2.2.1, "Configuring Reference Levels"](#), on page 244.
- Gate areas: restricting the waveform range for measurement can eliminate irregular data, see [chapter 7.2.3.6, "Using Gate Areas"](#), on page 258
- Defining a "Signal threshold" for amplitude vs. time measurements or a "Noise Reject" value for spectrum measurements can eliminate noise from the evaluation. See ["Signal threshold"](#) on page 266 and ["Noise reject"](#) on page 273.

To enable statistics

1. From the "Meas" menu, select "Setup".
2. Select the tab for the measurement you want to configure.
3. Tap the "Statistics" icon.

7.2.3.9 Using Environment Sensors

Environment sensors can provide additional information during a measurement, e.g. the temperature. The sensor results are displayed as a background color in the measurement diagram. Thus, the influence of temperature or humidity changes on the measurement results is visible directly.

1. On the "Meas" menu, select "Long Term/Statistics".
2. Select the tab for the measurement you want to combine with environment values.
3. Tap the "Use sensor" icon to enable the sensor measurement.
4. Below, select one of the connected environment sensors.
5. On the lower list, select temperature or humidity for evaluation.
6. Tap the "Setup sensor" button or select the "Sensors" tab to set up the sensor result display.
7. Select the tab for the sensor you want to configure.
8. Select the color table to be used with "Color table reference".
9. Enter the "Minimum value (0%)" and "Maximum value (100%)" to set the range of values displayed by a background color.
10. If necessary, edit the color table or create a new one as described in [chapter 5.1.2.1, "Editing Waveform Colors"](#), on page 178.

The background of the measurement diagram is colored according to the assigned color table.

7.2.4 Reference for Automatic Measurements

Automatic measurements are configured in the "Measurements" dialog box, which is opened via the "Meas > Setup" menu or via the "Measurements" result box, or by pressing the MEAS key. Up to 8 measurements can be defined. Each measurement is configured in its own tab.

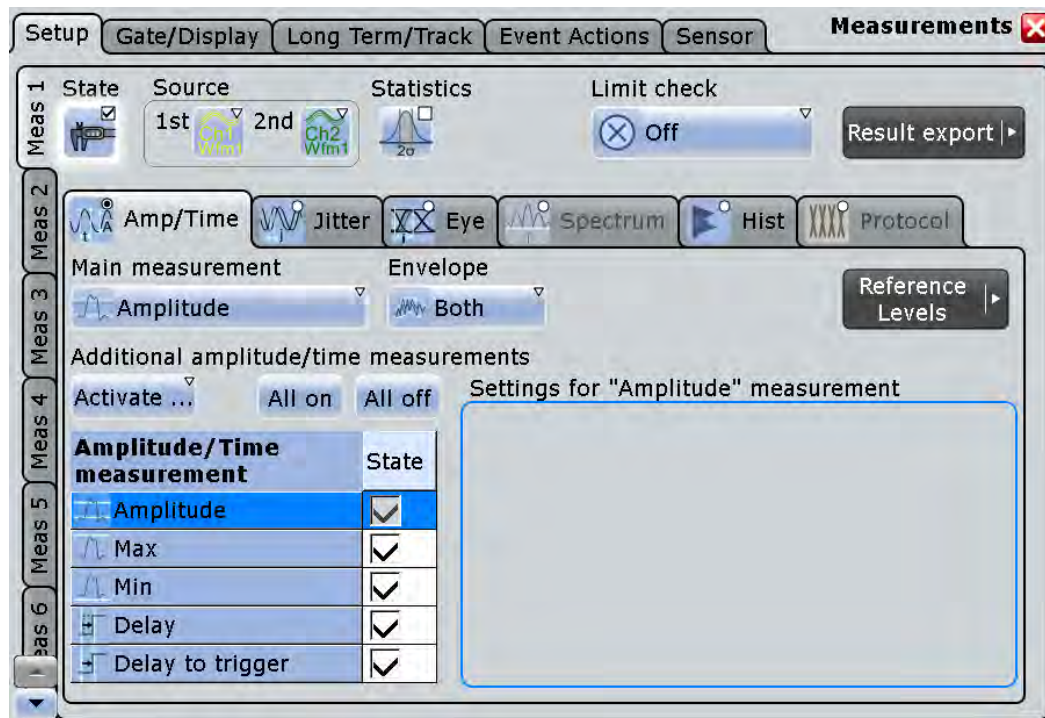

- [Measurements Setup - General Settings](#).....261
- [Measurements Setup - Amplitude/Time](#)264
- [Measurements Setup - Jitter](#).....270
- [Measurements Setup - Eye](#)270
- [Measurements Setup - Spectrum](#)271
- [Measurements Setup - Histograms](#).....273
- [Measurement Setup - Protocol](#).....275
- [Measurements - Gate/Display Tab](#).....275
- [Measurements - Long Term/Track](#).....278
- [Horizontal Long Term Scaling](#).....281
- [Measurements - Event Actions Tab](#).....282
- [Measurements - Sensors Tab](#).....284
- [Histogram Setup](#).....285

7.2.4.1 Measurements Setup - General Settings

The "Setup" tab of the "Measurements" dialog box contains the settings for the measurement types. Here you select the measurement sources and can also enable statistic evaluation and limit checks.



General settings in the upper part of the dialog box relate to all measurement types. Below, the measurement types are selected and configured. Depending on the selected source, not all measurement types are available. In the time domain, amplitude/time and eye/jitter measurements are available. In the frequency domain (i.e. for math channels with spectrum results), spectrum measurements are available. For measurements based on histograms, the histogram must be selected (available after the measurement type has been selected).

Meas 1/2/3/4/5/6/7/8

Selects one of the eight available measurements.

State

Enables the measurement waveform.

Remote command:

[MEASurement<m>\[:ENABLE\]](#) on page 790

Source

Defines the source of the measurement. The source can be any input signal, math or reference waveform. Depending on the selected source, not all measurement types are available.

Remote command:

[MEASurement<m>:SOURce](#) on page 790

2nd Source

Defines the second source of the measurement for some amplitude vs. time measurements (e.g. delay, phase). The source can be any input signal, math or reference waveform.

Remote command:

[MEASurement<m>:SOURce](#) on page 790

Statistics

Enables the calculation and display of statistics for the measurement results.

Remote command:

`MEASurement<m>:STATistics[:ENABLE]` on page 836

`MEASurement<m>:RESult:AVG?` on page 842

`MEASurement<m>:RESult:EVTCount?` on page 842

`MEASurement<m>:RESult:NPEak?` on page 842

`MEASurement<m>:RESult:PPEak?` on page 842

`MEASurement<m>:RESult:RMS?` on page 842

`MEASurement<m>:RESult:STDDev?` on page 842

`MEASurement<m>:RESult:WFMCCount?` on page 842

`MEASurement<m>:RESult[:ACTual]?` on page 842

Limit check

Enables limit checking. If the measurement results exceed the defined limits or margins, the actions specified under "Event Actions" are performed and an icon is displayed in the result box (see [chapter 7.2.1, "Measurements, Measurement Types, and Results"](#), on page 230). The limits and margins are defined for each measurement type in the measurement overview table. There you can also specify the valid range according to the following definitions:

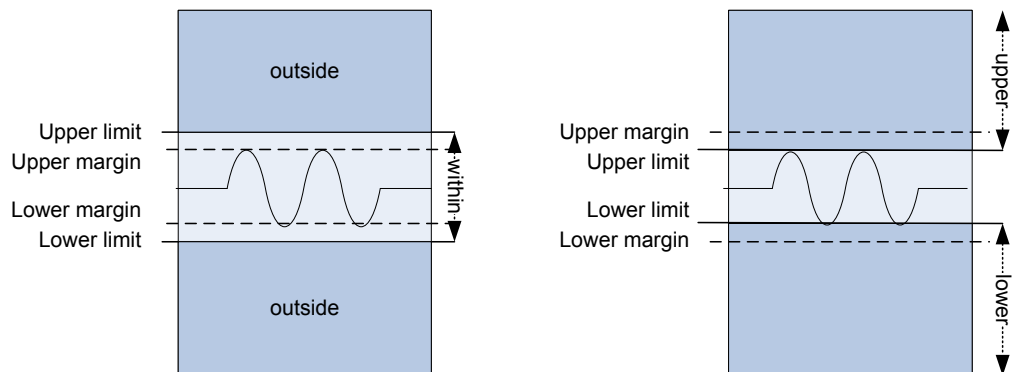

Fig. 7-3: Limit and margin definition

As indicated in [Limit and margin definition](#), limits are stricter than the margins for the value check. Thus, the margins must be within the valid range. If necessary, the limit and margin values are adapted according to the selected valid range.

- "Off" No limit check is performed.
- "Limit only" Limits are checked for violation.

"Margin and Limit" Margins and limits are checked for violation.

Remote command:

[MEASurement<m>:AMPTime:LCHeck<n>:LOWer:LIMit](#) on page 818

[MEASurement<m>:AMPTime:LCHeck<n>:LOWer:MARGin](#) on page 818

[MEASurement<m>:AMPTime:LCHeck<n>:UPPer:LIMit](#) on page 818

[MEASurement<m>:AMPTime:LCHeck<n>:UPPer:MARGin](#) on page 818

[MEASurement<m>:AMPTime:LCHeck<n>:VALid](#) on page 818

To check limits and margins of jitter measurements, use the AMPTime remote commands.

[MEASurement<m>:EYEJitter:LCHeck<n>:LOWer:LIMit](#) on page 820

[MEASurement<m>:EYEJitter:LCHeck<n>:LOWer:MARGin](#) on page 821

[MEASurement<m>:EYEJitter:LCHeck<n>:UPPer:LIMit](#) on page 820

[MEASurement<m>:EYEJitter:LCHeck<n>:UPPer:MARGin](#) on page 821

[MEASurement<m>:EYEJitter:LCHeck<n>:VALid](#) on page 820

[MEASurement<m>:HISTogram:LCHeck<n>:LOWer:LIMit](#) on page 833

[MEASurement<m>:HISTogram:LCHeck<n>:LOWer:MARGin](#) on page 833

[MEASurement<m>:HISTogram:LCHeck<n>:UPPer:LIMit](#) on page 833

[MEASurement<m>:HISTogram:LCHeck<n>:UPPer:MARGin](#) on page 833

[MEASurement<m>:HISTogram:LCHeck<n>:VALid](#) on page 832

[MEASurement<m>:SPECTrum:LCHeck<n>:LOWer:LIMit](#) on page 824

[MEASurement<m>:SPECTrum:LCHeck<n>:LOWer:MARGin](#) on page 824

[MEASurement<m>:SPECTrum:LCHeck<n>:UPPer:LIMit](#) on page 824

[MEASurement<m>:SPECTrum:LCHeck<n>:UPPer:MARGin](#) on page 824

[MEASurement<m>:SPECTrum:LCHeck<n>:VALid](#) on page 823

Measurement categories

For each measurement category, further settings can be configured on a subtab. The following categories are available:

- [chapter 7.2.4.2, "Measurements Setup - Amplitude/Time "](#), on page 264
- [chapter 7.2.4.4, "Measurements Setup - Eye "](#), on page 270
- [chapter 7.2.4.5, "Measurements Setup - Spectrum "](#), on page 271
- [chapter 7.2.4.6, "Measurements Setup - Histograms"](#), on page 273
- The "Jitter" category is only available if option R&S RTO-K12 is installed, see
- The "Protocol" category is only available for audio signals (option R&S RTOK5), see ["Track and Trend Settings in Measurement Setup"](#) on page 505.

7.2.4.2 Measurements Setup - Amplitude/Time

Amplitude and time measurements are only available for sources in the time domain.

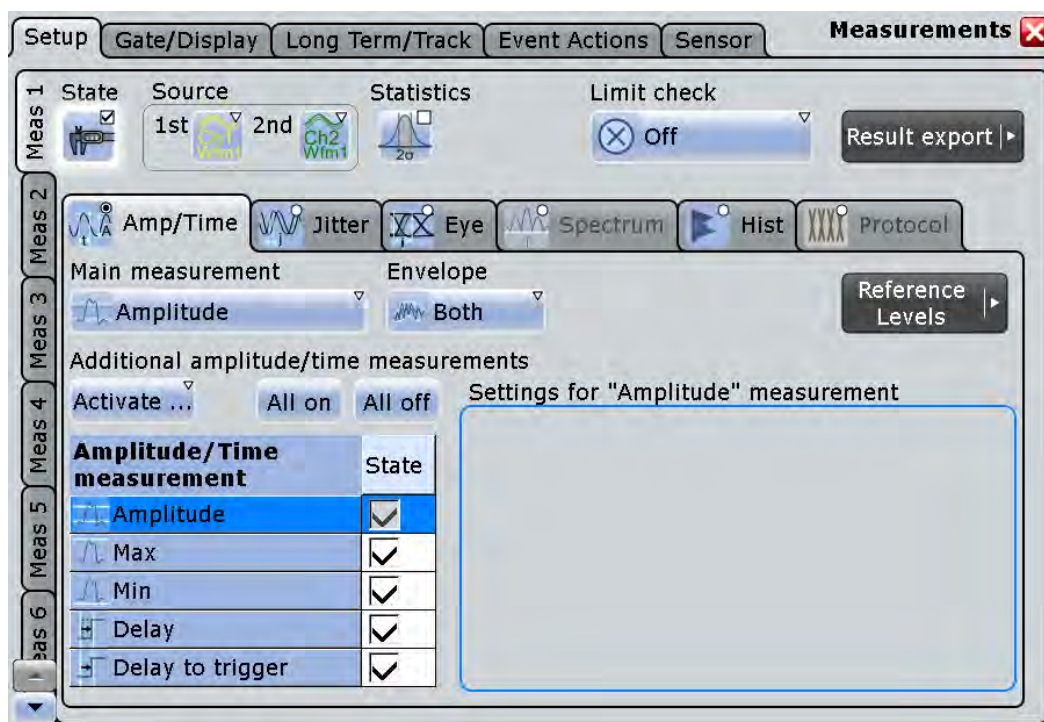

Main measurement

Defines the main amplitude/time measurement type. This measurement is the one referred to if the measurement waveform is used as a source for math calculations. The main measurement cannot be disabled in the measurement overview.

The default measurement in the time domain is "Amplitude". For details on the available measurement types, see [chapter 7.2.1.2, "Amplitude/Time Measurements"](#), on page 234.

Remote command:

`MEASurement<m>:MAIN` on page 792

Additional amplitude/time measurements

In addition to the main measurement, further amplitude/time measurement types can be performed simultaneously. The selected measurement types are displayed in an overview table. The main measurement is also listed in the overview table, but cannot be disabled here.

The overview table also contains the limit and margin definitions if a limit check is enabled, see ["Limit check"](#) on page 263.

Beside the table, specific settings for the selected measurement type are shown. When you select a measurement type, check and adjust its specific setting(s). Make sure that the limit check is disabled to see the specific settings.

For a description of available measurement types, see [chapter 7.2.1.2, "Amplitude/Time Measurements"](#), on page 234.

"Activate" opens the measurement table to select individual measurements

"All on" enables all available additional measurements.

"All off" Deactivates all selected measurements in the table.

Remote command:

[MEASurement<m>:ADDITIONal](#) on page 794

Envelope

This setting is only relevant for measurements on envelope waveforms, see "[Wfm Arithmetic](#)" on page 112. You can measure on:

"Both" The envelope is ignored and the waveform measured as usual. This value is also used by default if no envelope is defined.

"Maximum" the upper envelope

"Minimum" the lower envelope

Remote command:

[MEASurement<m>:ENVSelect](#) on page 813

Signal threshold

Defines a signal value that must be exceeded for the signal value to be included in the measurement. The setting is relevant for most amplitude/time measurement types.

Remote command:

[MEASurement<m>:DETThreshold](#) on page 813

Area level

The reference level used to integrate the waveform. The setting is only relevant for area measurements.

Remote command:

[MEASurement<m>:AMPTime:ALEVel](#) on page 814

Pulses slope

Sets the first slope of the pulses to be counted. The setting is available only for the "Pulse count" measurement. For example, with setting "Positive", the instrument counts positive pulses. Thus you can count either positive or negative pulses, or both.

Remote command:

[MEASurement<m>:AMPTime:PSLope](#) on page 814

Advanced Delay Setup

The specific settings for delay measurement allow you to measure the time between any two slopes at any reference level. Therefore, the reference level and the slope have to be defined for each source individually. The measurement result is negative if the edge of the second source comes before the edge of the first source.

Example:

With the settings shown in the picture, the time between the second rising edge and the third from last falling edge is measured.

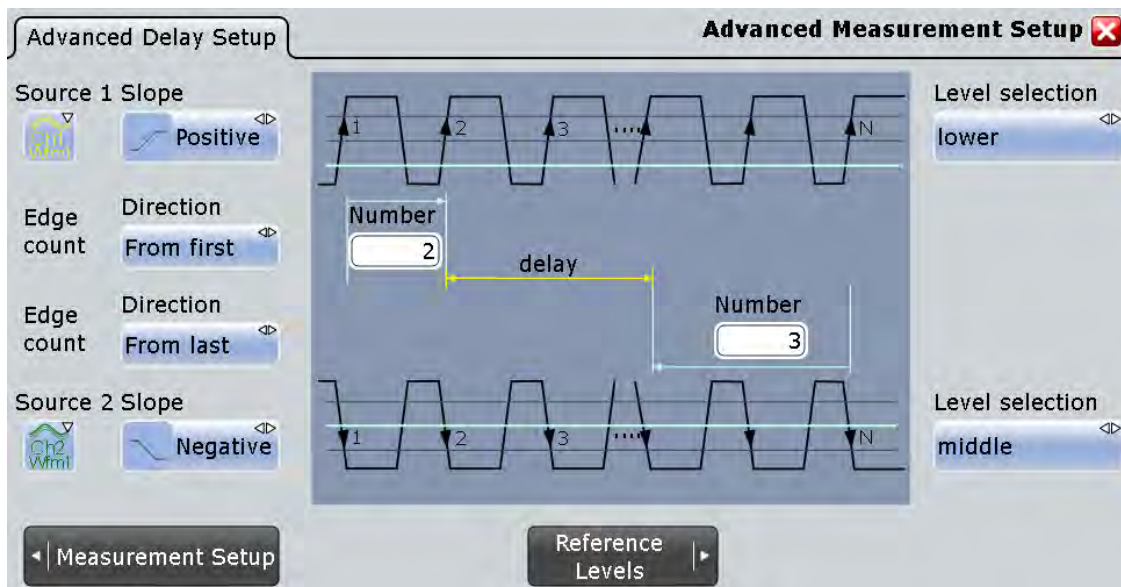

"Level selection" Selects the reference level on which the time is measured.

"Slope" Sets the edge of each source, between which the delay is measured: positive, negative, or either of them.

"Direction" Selects the direction for counting slopes for each source: from the beginning of the waveform, or from the end.

"Number" Sets the number of the edge that is relevant for delay measurement.

Remote command:

[MEASurement<m>:AMPTime:DELAy<n>:LSElect](#) on page 815

[MEASurement<m>:AMPTime:DELAy<n>:SLOPe](#) on page 815

[MEASurement<m>:AMPTime:DELAy<n>:DIRection](#) on page 814

[MEASurement<m>:AMPTime:DELAy<n>:ECOunt](#) on page 815

Setup/Hold measurement settings

Setup/Hold measurements analyze the relative timing between two signals: a data signal and the synchronous clock signal. Setup time is the time that the data signal is steady before clock edge - the time between a data transition and the next specified clock edge. Hold time is the time that the data signal is steady after clock edge - the time between a data transition and the previous specified clock edge.

Setup/Hold Time measures and displays the setup and hold durations. Setup/Hold Ratio measurements return the ratio of the setup time to the sum of hold and setup time: $T_{Setup} / (T_{Setup} + T_{Hold})$.

The clock edge can be defined, the polarity of the data signal does not matter.

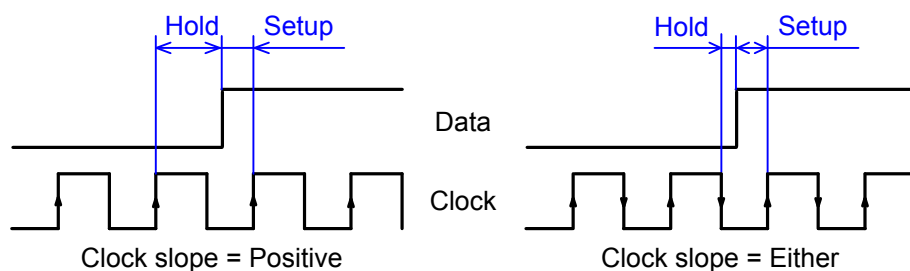

If at least one of the setup/hold measurements is selected, additional settings appear to specify the measurement.

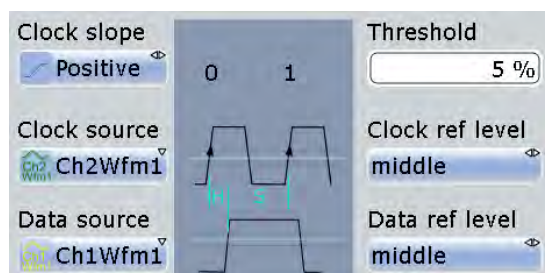

- "Clock slope" Sets the edge of the clock from which the setup and hold times are measured: positive, negative, or either of them. If "Either" is selected, the clock edges next to the data edge are considered regardless of the clock slope.
- "Clock source" The "Clock source" is identical to the measurement "Source". It defines the waveform used as clock in the setup/hold measurement.
- "Data source" The "Data source" is identical to the "2nd Source" of the measurement. It sets the data signal.
- "Clock ref level" Selects the reference level of the clock on which the time is measured. "Clock ref level" and "Clock slope" define the time point for setup and hold measurements.
- "Data ref level" Selects the reference level of the data on which the setup and hold time are measured.
- "Threshold" see ["Signal threshold"](#) on page 266

Remote command:

Clock slope: [MEASurement<m>:AMPTime:CSlope](#) on page 816

Clock reference level: [MEASurement<m>:AMPTime:CLCK<n>:LSElect](#) on page 816

Data reference level: [MEASurement<m>:AMPTime:DATA<n>:LSElect](#) on page 817

Pulse train count

Sets the number N of positive pulses for the "Pulse train" measurement. This measurement measures the duration of N positive pulses from the rising edge of the first pulse to the falling edge of the N-th pulse.

Remote command:

[MEASurement<m>:AMPTime:PTCount](#) on page 815

Edges slope

Sets the edge direction to be counted: rising edges, falling edges, or both. The setting is only relevant for edge count measurement.

Remote command:

`MEASurement<m>:AMPTime:ESLope` on page 816

Delay to trigger measurement settings

Delay to trigger measures the time between the trigger point and the following slope of a waveform. The delay between the trigger and the slope can be high compared to the accuracy of the acquisition, and the trigger point can even be outside of the current acquisition.

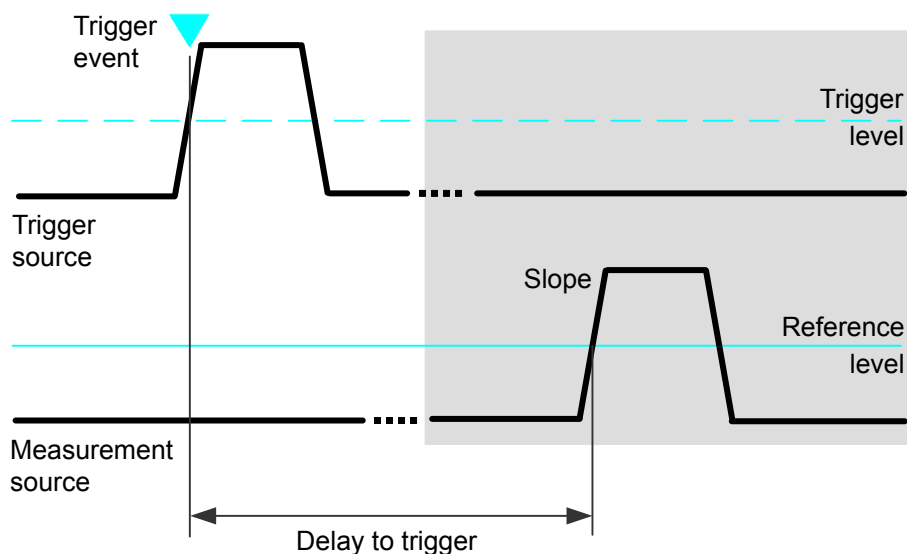

See also: [chapter 7.2.3.3, "Measuring the Delay to Trigger"](#), on page 256

To configure the trigger conditions, use the trigger setup. To set up the slope, additional settings appear in the measurements "Setup" dialog box.



"Edge slope" Sets the edge direction to be used for delay measurement: positive, negative, or either edge.

"Level selection" Selects the reference level of the measurement source on which the delay is measured: upper, middle, or lower level.

"Signal thresh- old" See ["Signal threshold"](#) on page 266

Remote command:

[MEASurement<m>:AMPTime:DTOTrigger<n>:SLOPe](#) on page 817

[MEASurement<m>:AMPTime:DTOTrigger<n>:LSElect](#) on page 817

7.2.4.3 Measurements Setup - Jitter

The "Jitter" category is only available if option R&S RTO-K12 is installed, see [chapter 17.1, "Jitter Measurements"](#), on page 545.

7.2.4.4 Measurements Setup - Eye

Eye diagram measurements are only available for sources in the time domain.

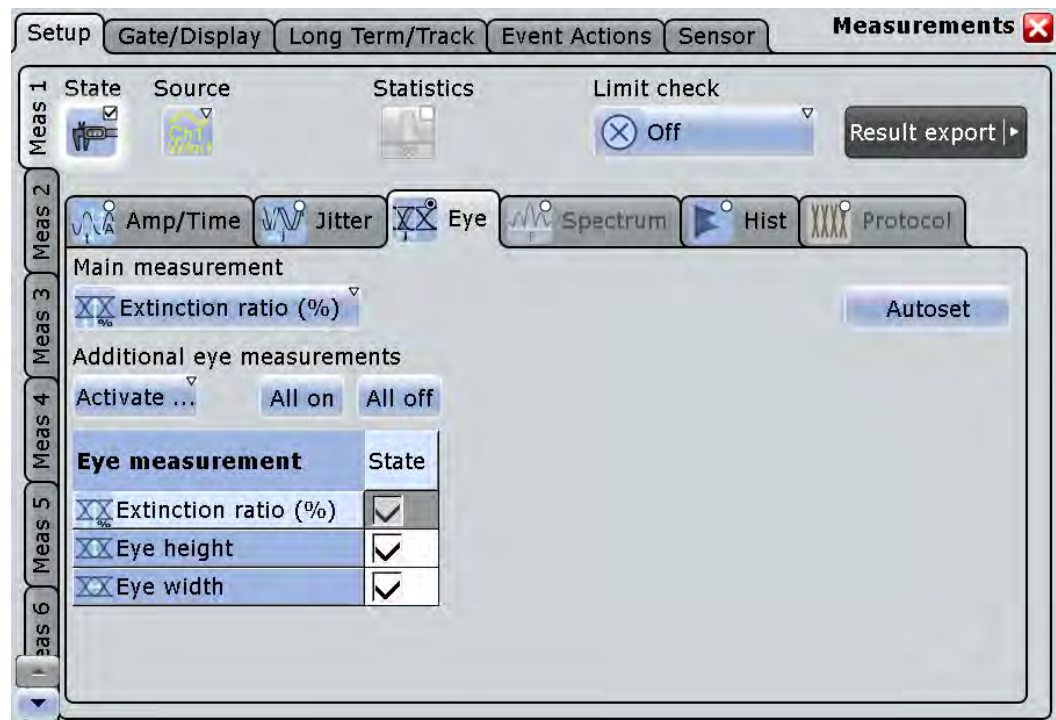

To obtain optimized settings for an eye measurement, use the "Autoset" function that is provided on the right side of the "Eye" tab.

Main measurement

Defines the main eye measurement type. This measurement is the one referred to if the measurement waveform is used as a source for math calculations. The main measurement cannot be disabled in the measurement overview.

For a description of available measurement types, see [chapter 7.2.1.3, "Eye Diagram Measurements"](#), on page 238.

Remote command:

`MEASurement<m>:MAIN` on page 792

Additional eye measurements

In addition to the main measurement, further eye diagram measurements can be performed simultaneously. The selected measurements are displayed in an overview table. The main measurement is also listed in the overview table, but cannot be disabled here.

The overview table also contains the limit and margin definitions if a limit check is enabled, see ["Limit check"](#) on page 263.

For a description of available measurement types, see [chapter 7.2.1.3, "Eye Diagram Measurements"](#), on page 238.

"Activate" opens the measurement table to select individual measurements

"All on" enables all available additional measurements.

"All off" Deactivates all selected measurements in the table.

Remote command:

`MEASurement<m>:ADDITIONal` on page 794

Autoset

Defines optimized settings to perform an eye diagram measurement for the selected source.

7.2.4.5 Measurements Setup - Spectrum

Spectrum measurements are only available if a source in the frequency domain is selected, i.e. a math waveform with an FFT operation.

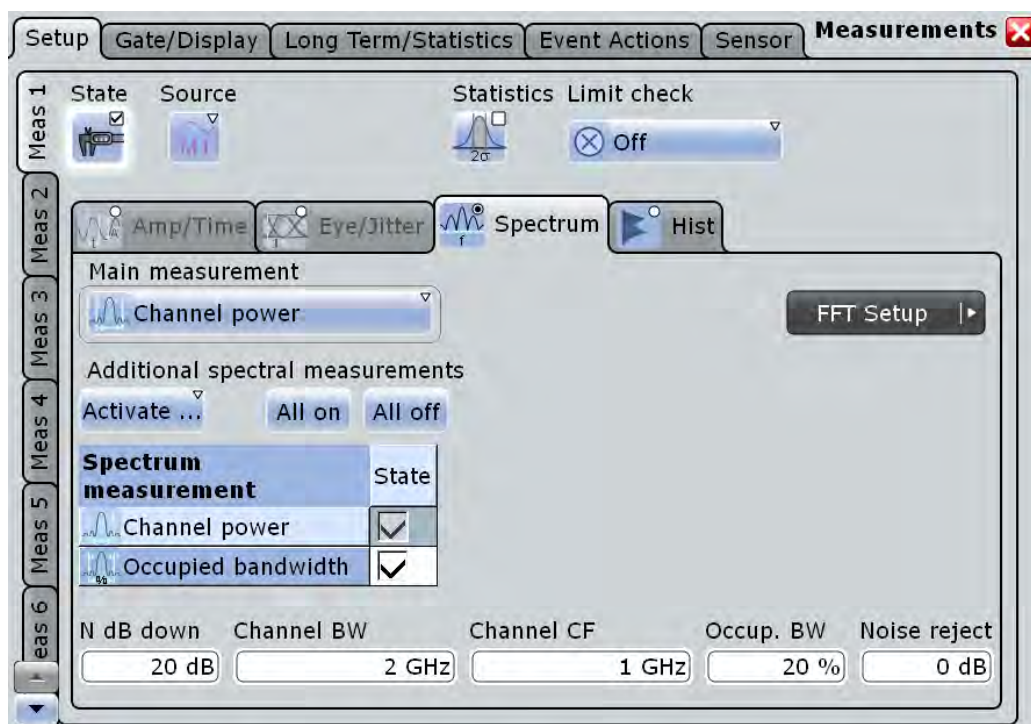

Main measurement

Defines the main spectrum measurement type. This measurement is the one referred to if the measurement waveform is used as a source for math calculations. The main measurement cannot be disabled in the measurement overview.

For a description of available measurement types, see [chapter 7.2.4.5, "Measurements Setup - Spectrum"](#), on page 271.

Remote command:

[MEASurement<m>:MAIN](#) on page 792

Additional spectrum measurements

In addition to the main measurement, further spectrum measurements can be performed simultaneously. The selected measurements are displayed in an overview table. The main measurement is also listed in the overview table, but cannot be disabled here.

The overview table also contains the limit and margin definitions if a limit check is enabled, see ["Limit check"](#) on page 263.

For a description of available measurement types, see ["Main measurement"](#) on page 272.

"Activate" opens the measurement table to select individual measurements

"All on" enables all available additional measurements.

"All off" Deactivates all selected measurements in the table.

Remote command:

[MEASurement<m>:ADDITIONal](#) on page 794

N db down

The threshold until which the samples to the left and right of the peak value are analyzed in order to determine the "(N dB down) Bandwidth".

Remote command:

[MEASurement<m>:SPECTrum:NDBDown](#) on page 823

Channel BW

Bandwidth over which the channel power is calculated.

Remote command:

[MEASurement<m>:SPECTrum:CPOWer:BANDwidth](#) on page 822

Channel CF

Center frequency from which the channel power is calculated over the specified bandwidth.

Remote command:

[MEASurement<m>:SPECTrum:CPOWer:CFRequency](#) on page 823

Occup. BW

Percentage of the total power used to determine the occupied bandwidth.

Remote command:

[MEASurement<m>:SPECTrum:OBANDwidth](#) on page 822

Noise reject

Threshold beneath which values are rejected as noise.

Remote command:

[MEASurement<m>:SPECTrum:NREJect](#) on page 823

7.2.4.6 Measurements Setup - Histograms

You can perform measurements on an existing histogram. Histograms are defined in the "Histogram" dialog box (accessible via the MEAS menu).

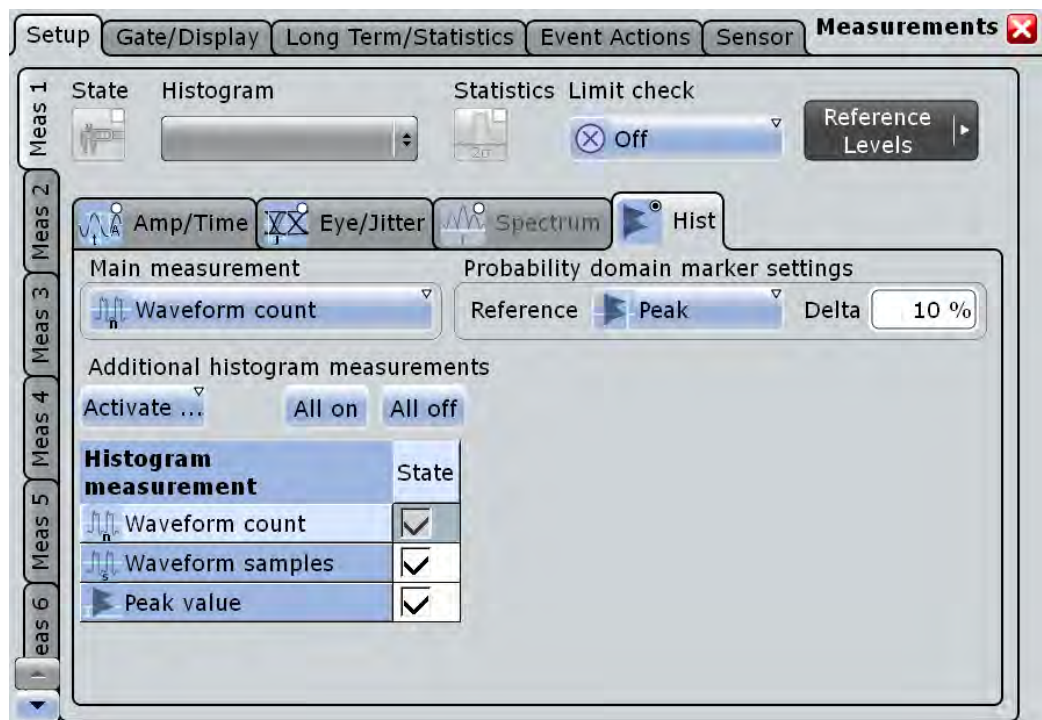

Histogram

Selects the histogram on which the measurement is based. Histograms are defined via the "MEAS > Histogram" menu item.

Remote command:

[MEASurement<m>:HISTogram:SElect](#) on page 831

Main measurement

Defines the main histogram measurement type. This measurement is the one referred to if the measurement waveform is used as a source for math calculations. The main measurement cannot be disabled in the measurement overview.

For a description of available measurement types, see [chapter 7.2.1.4, "Histograms"](#), on page 240.

Remote command:

[MEASurement<m>:MAIN](#) on page 792

Additional histogram measurements

In addition to the main measurement, further histogram measurements can be performed simultaneously. The selected measurements are displayed in an overview table. The main measurement is also listed in the overview table, but cannot be disabled here.

The overview table also contains the limit and margin definitions if a limit check is enabled, see ["Limit check"](#) on page 263.

For a description of available measurement types, see ["Main measurement"](#) on page 274.

"Activate" opens the measurement table to select individual measurements

- "All on" enables all available additional measurements.
 "All off" Deactivates all selected measurements in the table.

Remote command:

[MEASurement<m>:ADDITIONal](#) on page 794

Probability domain marker reference

Defines the marker reference in the probability domain.

- "Peak" The y-value with the maximum sample value in the histogram
 "Upper Peak" The y-value at the maximum sample value in the upper half of the histogram
 "Lower Peak" The y-value at the maximum sample value in the lower half of the histogram
 "Maximum" The highest y-value with a probability > 0
 "Minimum" The lowest y-value with a probability > 0
 "Median" The y-value for which half the samples lie above, the other half below in the histogram
 "Mean" The weighted arithmetic average of the histogram

Remote command:

[MEASurement<m>:HISTogram:PROBability:TYPE](#) on page 831

Delta

Defines a range around the marker.

Remote command:

[MEASurement<m>:HISTogram:PROBability:LIMit](#) on page 832

7.2.4.7 Measurement Setup - Protocol

The "Protocol" category is only available for audio signals, see ["Track and Trend Settings in Measurement Setup"](#) on page 505.

7.2.4.8 Measurements - Gate/Display Tab

The settings on this tab define the measurement gate and the display of results.

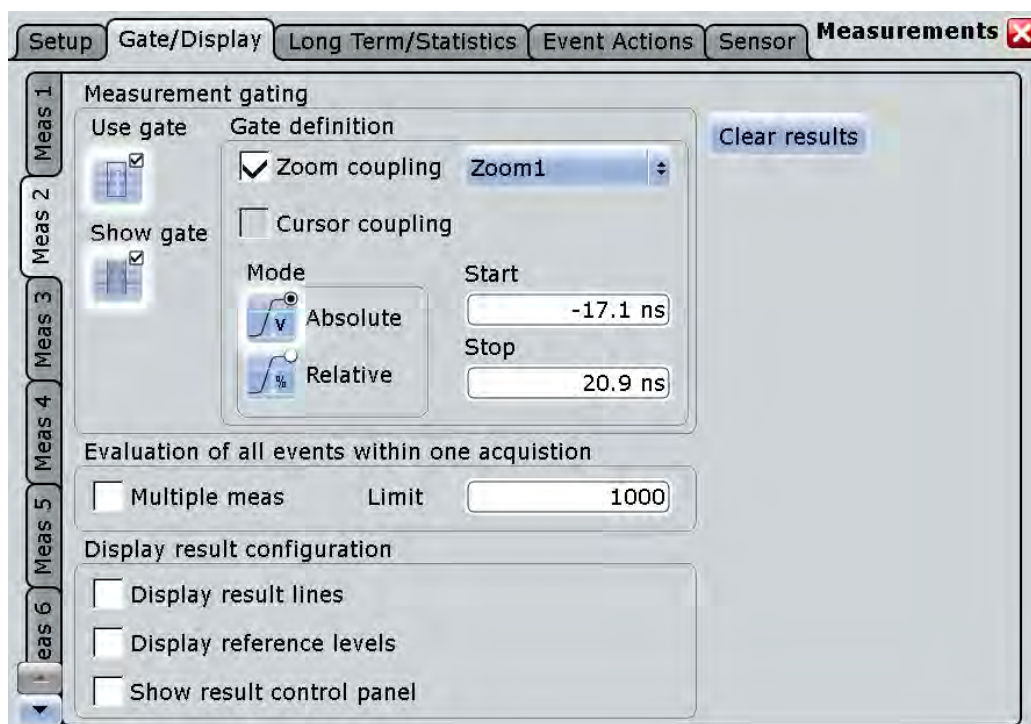
**Meas 1/2/3/4/5/6/7/8**

Selects one of the eight available measurements.

Use gate

Considers the gating settings of the source waveform for the measurement.

Remote command:

[MEASurement<m>:GATE\[:STATE\]](#) on page 844

Show gate

Displays the gate area in the source diagram.

Remote command:

[CALCulate:MATH<m>:FFT:GATE:SHOW](#) on page 858

[MEASurement<m>:GATE:SHOW](#) on page 845

[SEARCH:GATE:SHOW](#) on page 904

Gate definition

Defines the gate settings for measurement gating.

Zoom coupling ← Gate definition

Zoom coupling is available if a zoom is defined. As long as "Zoom coupling" is enabled, the gate area is defined identically to the zoom area - if you change the zoom, the gate changes as well.

If several zoom diagrams are defined, select the zoom diagram to be used for gating. The "Start" and "Stop" values of the gate are adjusted accordingly.

Zoom coupling can be set for measurement gates, FFT gates, and search gates.

Remote command:

[CALCulate:MATH<m>:FFT:GATE:ZCOupling](#) on page 858

[MEASurement<m>:GATE:ZCOupling](#) on page 845

[SEARch:GATE:ZCOupling](#) on page 905

[SEARch:GATE:ZDIagram](#) on page 905

Cursor coupling ← Gate definition

If enabled, the gate area is defined by the cursor lines of an active cursor measurement. If several cursor measurements are enabled, select the cursor set to be used for gating. The "Start" and "Stop" values of the gate are adjusted to the values of the cursor line positions limiting the measurement to the part of the waveform between the cursor lines.

Mode ← Gate definition

Defines whether the gate settings are configured using absolute or relative values.

"Absolute" The gate is defined by absolute start and stop values.

"Relative" The gate's start and stop values are defined by a percentage of the value range.

Remote command:

[CALCulate:MATH<m>:FFT:GATE:MODE](#) on page 857

[MEASurement<m>:GATE:MODE](#) on page 844

[SEARch:GATE:MODE](#) on page 904

(Relative) Start ← Gate definition

Defines the starting value for the gate.

Remote command:

[CALCulate:MATH<m>:FFT:GATE:ABSolute:START](#) on page 857

[CALCulate:MATH<m>:FFT:GATE:RELative:START](#) on page 858

[MEASurement<m>:GATE:ABSolute:START](#) on page 844

[MEASurement<m>:GATE:RELative:START](#) on page 844

[SEARch:GATE:ABSolute:START](#) on page 904

[SEARch:GATE:RELative:START](#) on page 905

(Relative) Stop ← Gate definition

Defines the end value for the gate.

Remote command:

[CALCulate:MATH<m>:FFT:GATE:ABSolute:STOP](#) on page 857

[CALCulate:MATH<m>:FFT:GATE:RELative:STOP](#) on page 858

[MEASurement<m>:GATE:ABSolute:STOP](#) on page 844

[MEASurement<m>:GATE:RELative:STOP](#) on page 844

[SEARch:GATE:ABSolute:STOP](#) on page 904

[SEARch:GATE:RELative:STOP](#) on page 905

Multiple measurement

Performs multiple measurements on the same source waveform and includes the results in evaluation. For example, it measures the rise time for all pulses in the waveform, not only the first. This is useful when calculating statistics or generating tracks; however, it reduces the performance of the instrument.

The number of considered measurement results can be restricted, see [Limit](#).

Remote command:

`MEASurement<m>:MULTiple` on page 796

Limit

Sets the maximum number of measurements per acquisition if "Multiple measurement" is enabled.

Remote command:

`MEASurement<m>:MNOMeas` on page 796

Display result lines

Displays intermediate result lines in the measurement waveform (e.g. signal thresholds) required to obtain the measurement result.

Remote command:

`MEASurement<m>:DISPlay:RESults` on page 834

Display reference levels

Displays the reference levels used for the measurement in the diagram.

Remote command:

`MEASurement<m>:DISPlay:LEVels` on page 834

Show result control panel

Extends the result box of the current measurement with the source settings and the statistics enabling. Thus you can check and change the measurement sources directly in the results box, and also enable statistics there.

Clear Results

Clears the measurement results including statistical results in the measurement results table.

To clear results of long term measurements and histograms, use "Reset now" on the "Long Term/Track" tab. To delete all results and waveforms, select "Display" menu > "Clear screen results".

7.2.4.9 Measurements - Long Term/Track

Access: "Meas" menu > "Long Term/Statistics"

The settings in this tab allow you to configure long term measurements, including statistics and measurement histogram over a longer period of time.

For scaling settings, see [chapter 7.2.4.10, "Horizontal Long Term Scaling"](#), on page 281.

If option R&S RTO-K5 I²S Audio Signals is installed, you can configure track and trend analysis in this tab, see [chapter 14.8.5, "Track and Trend"](#), on page 502.

If option R&S RTO-K12 Basic Jitter Analysis is installed, you can use tracks to display the jitter measurement results of an acquisition as a time-correlated waveform, see [chapter 17.1.5, "Track of Jitter Measurement Results"](#), on page 552.



Meas 1/2/3/4/5/6/7/8

Selects one of the eight available measurements.

Enable (Long term)

Enables long term measurement of the main measurement.

Remote command:

[MEASurement<m>:LTMeas\[:STATe\]](#) on page 839

Statistics

Enables the calculation and display of statistics for the measurement results.

Remote command:

[MEASurement<m>:STATistics\[:ENABle\]](#) on page 836

[MEASurement<m>:RESult:AVG?](#) on page 842

[MEASurement<m>:RESult:EVTCount?](#) on page 842

[MEASurement<m>:RESult:NPEak?](#) on page 842

[MEASurement<m>:RESult:PPEak?](#) on page 842

[MEASurement<m>:RESult:RMS?](#) on page 842

[MEASurement<m>:RESult:STDDev?](#) on page 842

[MEASurement<m>:RESult:WFMCCount?](#) on page 842

[MEASurement<m>:RESult\[:ACTual\]?](#) on page 842

Enable (Histogram)

Displays a histogram of compatible measurement results - the cumulative occurrence distribution of measurement results in a graphic. The histogram shows all enabled measurement types that are compatible with the main measurement, for example, all voltage measurements if the main measurement is "Amplitude".

Remote command:

[MEASurement<m>:STATistics:HISTogram](#) on page 836

Enable (Track)

Enables the track measurement and displays the track of the selected .

The track is available with the following applications:

- Option R&S RTO-K5 I²S Audio Signals
If this option is installed and decoding results of an audio bus are available, the track can be displayed for the selected [Audio channel](#).
See also: [chapter 14.8.5.1, "Track"](#), on page 502.
- Option R&S RTO-K12 Basic Jitter Analysis
If this option is installed, you can use tracks to display the jitter measurement results of an acquisition as a time-correlated waveform, see [chapter 17.1.5, "Track of Jitter Measurement Results"](#), on page 552.

Remote command:

[MEASurement<m>:TRACk\[:STATe\]](#) on page 840

Meas scaling

The measurement scale of a long term measurement diagram or measurement histogram can be set automatically by the instrument, or manually.

Use automatic scaling if the measurement is running and you cannot see the expected results.

"Continuous auto scale"

Performs an automatic scaling whenever the long term waveform or the histogram does not fit in the diagram during the measurement period.

"Auto scale"

Performs an automatic scaling once so that the scaling is adapted to the current measurement results. Available only for long term measurement.

"Meas scale"

Defines the scaling per division for long term measurement period and the measurement histogram.

"Meas offset"

Defines an offset for the long term measurement and the measurement histogram.

Remote command:

[MEASurement<m>:VERTical:CONT](#) on page 838

[MEASurement<m>:VERTical:AUTO](#) on page 838

[MEASurement<m>:VERTical:SCALE](#) on page 839

[MEASurement<m>:VERTical:OFFSet](#) on page 838

Reset now

Resets the histogram, the long term measurement and the statistics.

Stopping and starting the acquisition does not reset these analyses but only stops and continues them.

To clear only statistical results, use "Clear results" on the "Gate/Display" tab. To delete all results and waveforms, select "Display" menu > "Clear screen results".

Remote command:

[MEASurement<m>:STATistics:RESet](#) on page 838

7.2.4.10 Horizontal Long Term Scaling

In this dialog box, you define the horizontal scale of long term measurement diagrams. The length of the long term measurement is defined by the number of points.

If option R&S RTO-K5 I²S Audio Signals is installed, the trend diagram is configured here.

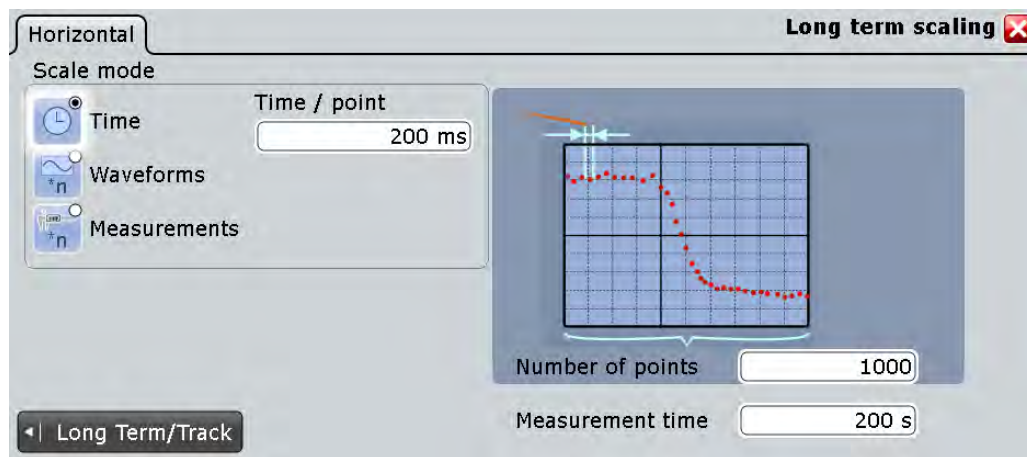

Number of points

Defines the total number of points to be displayed in the long term measurement diagram.

Remote command:

[MEASurement<m>:LTMeas:COUNT](#) on page 839

Scale mode

Defines when the points of a long term measurement are created.

If statistics are enabled, each long term measurement point shows the statistical mean and standard deviation of the results measured during the defined period.

If statistics are disabled, the first measurement result of each period is taken as long term measurement point.

- "Time" Sets one long term measurement point for the time defined in "Time/point".
- "Waveforms" Sets one long term measurement point for a number of acquired waveforms defined in "Waveforms/point".

"Measure-
ments" Sets one long term measurement point for a number of measurement results defined in "Measurements/point".

Remote command:

[MEASurement<m>:STATistics:MODE](#) on page 836

Time/point

Defines the time to create one point of the long term measurement.

This setting is only available if "Scale mode" is set to "Time".

Remote command:

[MEASurement<m>:STATistics:RTIME](#) on page 837

Measurement time

Defines the total duration of the long term measurement: *Time/point * Number of points*.

This setting is only available if "Scale mode" is set to "Time".

Remote command:

[MEASurement<m>:LTMeas:TIME](#) on page 840

Waveforms/point

Defines the number of measured waveforms from which one point of the long term measurement is created.

This setting is only available if "Scale mode" is set to "Waveforms".

Remote command:

[MEASurement<m>:STATistics:RCOunt](#) on page 837

Measurements/point

Defines the number of measurement results from which one point of the long term measurement is created.

This setting is only available if "Scale mode" is set to "Measurements".

Remote command:

[MEASurement<m>:STATistics:RMEascount](#) on page 837

7.2.4.11 Measurements - Event Actions Tab

The settings in this tab define what happens when the limits and margins defined in the "Setup" tab are exceeded if limit checking is enabled. Independent of these settings, an icon is displayed in the result box, see "[Status icons](#)" on page 232.

Note that the violation actions do not distinguish between a margin violation and a limit violation. However, different icons are displayed in the result box.

For each action, you can define the event on which the action is initiated:

- On violation
The action is initiated as soon as the limits or margins are exceeded during the measurement.
- On successful completion

The action is initiated when the RUN N× SINGLE acquisition has finished and the limits or margins were not exceeded.



Meas 1/2/3/4/5/6/7/8

Selects one of the eight available measurements.

Beep

Generates a beep sound.

Remote command:

[MEASurement<m>:ONViolation:BEEP](#) on page 846

Stop acq

Stops data acquisition on violation.

Remote command:

[MEASurement<m>:ONViolation:ACQStop](#) on page 846

Print

Prints a screenshot including the measurement results to the printer defined in the "Print" dialog box (see [chapter 11.1.1, "Configuring Printer Output and Printing"](#), on page 360).

Remote command:

[MEASurement<m>:ONViolation:PRINT](#) on page 846

Save Wfm

Saves the waveform data to the file specified in FILE > "Save/Recall" > "Waveform".

Remote command:

[MEASurement<m>:ONViolation:WFMSave](#) on page 846

Trigger Out Pulse

Creates a pulse on the EXT TRIGGER OUT connector on limit violation. Additionally, the measurement and the limit check must be enabled to create the trigger out pulse.

If these three conditions are fulfilled, the trigger control option "Enable trigger out" is disabled. Thus, the trigger out pulse is created only on limit violation but not when a trigger occurs. The pulse is provided always with the minimum delay of 800 ns, the "Delay" cannot be set.

Visible histogram

Shows the number of currently shown histograms.

7.2.4.12 Measurements - Sensors Tab

Environment sensors can provide additional information during a measurement, e.g. the temperature. The sensor results are displayed as a background color according to the selected color table in the measurement diagram. Thus, the influence of temperature or humidity changes on the measurement results is visible directly.

The "Sensors" tab contains the settings for the display of sensor measurement results and the currently measured value. Each connected sensor has its own settings tab. For each sensor, two tabs are available to set up the display of temperature and humidity results.

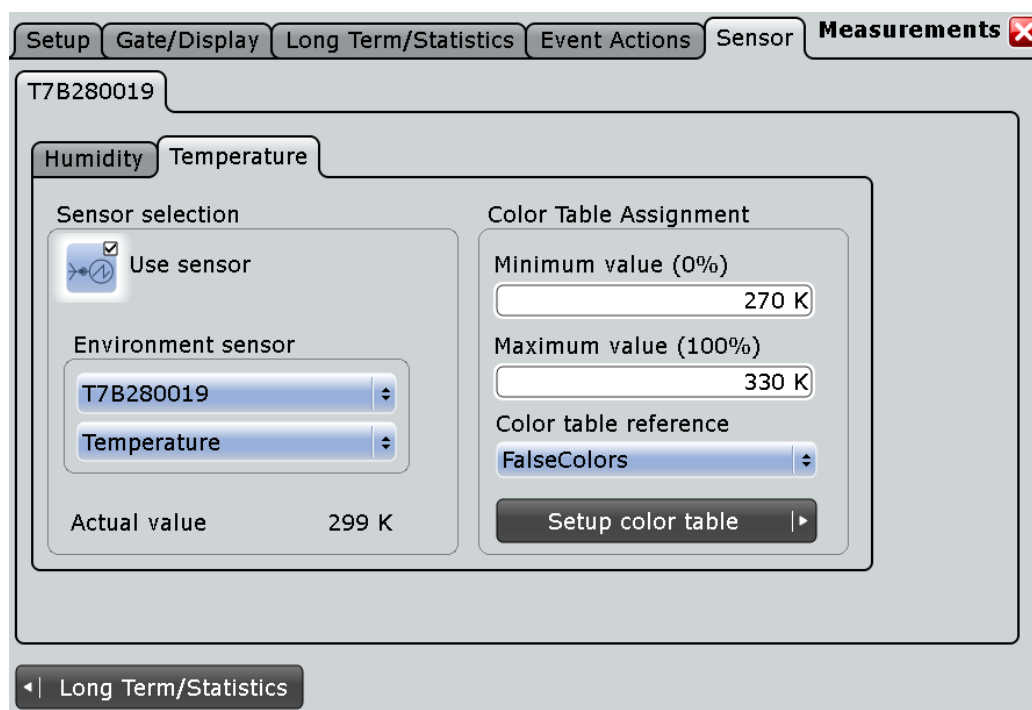

To select the sensor and enable it for a measurement, select the [chapter 7.2.4.9, "Measurements - Long Term/Track"](#), on page 278.

See also: [chapter 7.2.3.9, "Using Environment Sensors"](#), on page 260

Environment sensor

Environment sensors measure temperature and humidity around the instrument. They can be connected to the USB ports on the front or rear panel. The display of the sensor measurement results is configured in the [chapter 7.2.4.12, "Measurements - Sensors Tab"](#), on page 284.

See also: [chapter 7.2.3.9, "Using Environment Sensors"](#), on page 260

- "Use sensor": Enables the environment measurement.

- "Environment sensor": Selects one of the connected sensors in the upper list and the environment measurement type in the lower list.

Remote command:

[MEASurement<m>:LTMeas:ENVSensor:STATe](#) on page 840

Actual value

Indicates the currently measured sensor value.

Minimum value (0%), Maximum value (100%)

Minimum and maximum values define the range of values that is displayed as background color.

"Minimum value (0%)" defines the temperature or humidity value that is assigned to the 0%-color of the color table. "Maximum value (100%)" defines the value assigned to the 100%-color, respectively.

Color table reference

Assigns one of the available color tables to the sensor results. The background of the measurement diagrams using the selected sensor is colored according to the assigned color table.

For details on color tables, see [chapter 5.1.2.1, "Editing Waveform Colors"](#), on page 178.

7.2.4.13 Histogram Setup

In this dialog box you configure histograms on which you can perform further measurements (see [chapter 7.2.1.4, "Histograms"](#), on page 240).

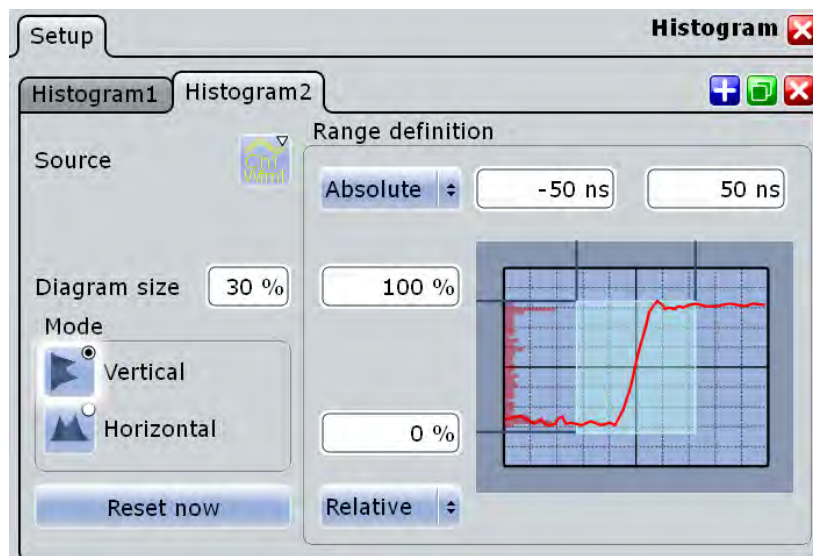

Source

Defines the source of the histogram. Any analog channel waveform, math or reference waveform can be selected. Also measurements can serve as histogram source. In this case, the density distribution of the results of the main measurement is displayed.

Remote command:

[LAYout:HISTogram:SOURce](#) on page 826

Diagram size

Defines the size of the histogram in percent of the diagram.

Mode

Defines the type of histogram.

"Vertical" Amplitude histogram (horizontal bars across amplitude)

"Horizontal" Time histogram (vertical bars over time). For FFT waveforms, horizontal histograms over spectrum are not available.

Remote command:

[LAYout:HISTogram:MODE](#) on page 826

Reset now

Resets the values to begin a new histogram.

Remote command:

[LAYout:HISTogram:RESet](#) on page 829

Range definition mode (Absolute/Relative)

Defines whether the value range limits are entered as absolute or relative values.

Remote command:

[LAYout:HISTogram:HORZ:MODE](#) on page 827

[LAYout:HISTogram:VERTical:MODE](#) on page 828

Horizontal start/stop value

Defines the horizontal value range of the histogram.

Remote command:

[LAYout:HISTogram:HORZ:ABSolute:START](#) on page 827

[LAYout:HISTogram:HORZ:ABSolute:STOP](#) on page 827

[LAYout:HISTogram:HORZ:RELative:START](#) on page 827

[LAYout:HISTogram:HORZ:RELative:STOP](#) on page 828

Vertical start/stop value

Defines the vertical value range of the histogram.

Remote command:

[LAYout:HISTogram:VERTical:ABSolute:START](#) on page 828

[LAYout:HISTogram:VERTical:ABSolute:STOP](#) on page 828

[LAYout:HISTogram:VERTical:RELative:START](#) on page 829

[LAYout:HISTogram:VERTical:RELative:STOP](#) on page 829

8 Mathematics

The R&S RTO provides different methods of creating mathematical waveforms:

- Applying mathematical functions to source data
- Performing FFT analysis on source data

8.1 Mathematical Waveforms

Math waveforms are the results of various calculations or FFT analysis. You can define up to four math waveforms and display them on the screen, and/or use it as source for further analysis.

You can also store a math waveform as a reference waveform and restore it any time later, see ["To save a reference waveform"](#) on page 214.

The vertical scale of a math waveform is adapted automatically to the measurement results to ensure optimal display. Furthermore, you can scale each math waveform manually in vertical direction like a channel waveform.

As for channel waveforms, you can also change the arithmetic mode for the waveform to display the envelope or an average over several calculations.

8.1.1 Displaying Math Waveforms

Math waveforms can be displayed in addition to the channel and other waveforms. They also can be used for analysis, e.g. measurements, even if the math waveform is not active.

1. In the "Math" menu, select "Math Setup", or press the MATH key.
2. Define the math expression to be calculated in one of the following ways:
 - [chapter 8.2.1.1, "Defining a Formula in the Basic Editor"](#), on page 291
 - [chapter 8.2.2.1, "Defining a Formula in the Advanced Formula Editor"](#), on page 293
 - [chapter 8.3.2, "Configuring FFT Waveforms"](#), on page 303
3. In the "Math Setup" dialog box, in the "Setup" tab, tap the "Enable math signal" icon so it is highlighted.

The math waveform is displayed on the screen.

4. To change the vertical scaling of the math waveform, tap the "Manual" icon, then enter the "Vertical scale" factor (per division) and add, if necessary, a "Vertical offset". By default, automatic scaling is performed.

Tip: You can also use the vertical SCALE rotary knob for scaling. In this case, the scale mode is set to "Manual" temporarily.

5. If you need the envelope or average of the math waveform over several calculations, change the arithmetic mode for the waveform as for channel waveforms. See also: "[Wfm Arithmetic](#)" on page 112.
6. Close the "Math Setup" dialog box.

8.1.2 Math Setup

You can define up to 4 different math waveforms. Each waveform is defined in a separate tab in the "Math" dialog box ("Math 1"- "Math 4").

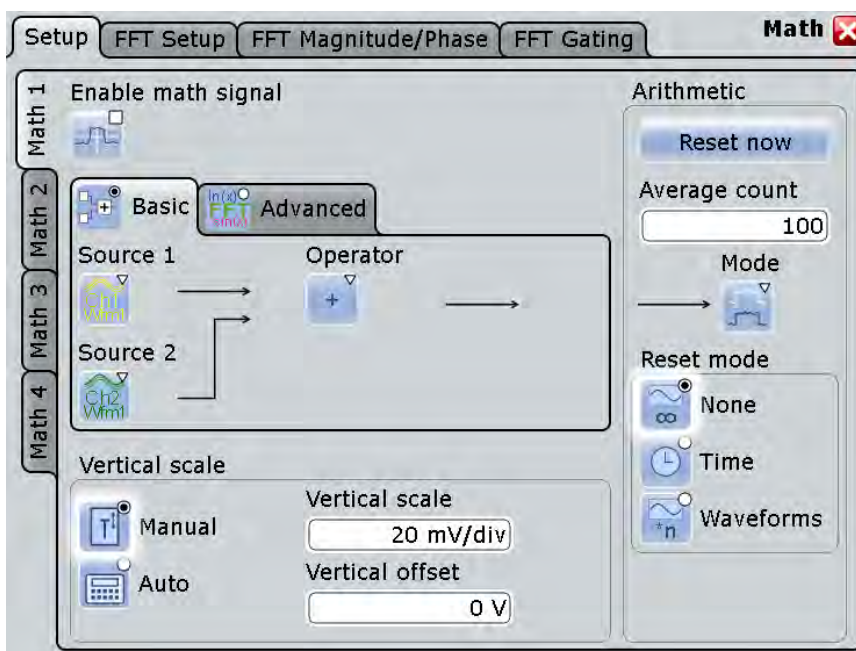

The settings for input of mathematical formulas in basic and advanced editors are described in separate chapters:

- [chapter 8.2.1.2, "Settings in the Basic Editor"](#), on page 292
- [chapter 8.2.2.2, "Advanced Formula Editor"](#), on page 294

The general settings for enabling, scaling and waveform arithmetic are:

Enable Math Signal	289
Vertical Scale	289
L Vertical scale mode (Manual/Auto)	289
L Vertical Scale	289
L Vertical Offset	289
Arithmetic	289
L Reset Now	290
L Acquisition/average count	290
L Mode	290
L Reset mode	290

Enable Math Signal

If activated, a diagram for the defined math waveform is displayed on the touch screen.

Remote command:

[CALCulate:MATH<m>:STATe](#) on page 847

Vertical Scale

Functions to set the vertical parameters of the math waveform.

Note: If an FFT expression is defined, the vertical scaling for spectrum displays is available: "Vertical maximum" and "Vertical range" instead of "Vertical Scale" and "Vertical Offset". See [chapter 8.3.3.2, "FFT Magnitude/Phase"](#), on page 309.

Vertical scale mode (Manual/Auto) ← Vertical Scale

By default, the vertical scale is adapted to the current measurement results automatically to provide an optimal display. However, if necessary, you can define scaling values manually to suit your requirements.

Note: When you change the scaling values manually using the "Scale" rotary knob, the scale mode is set to "Manual" temporarily. When you edit the math function, scaling is automatically set back to "Auto" mode. "Manual" mode is only maintained during math function changes if you select it yourself.

"Manual" Enter the required values for "Vertical scale" and "Vertical offset". For FFT, set "Vertical range" and "Vertical maximum".

"Auto" "Vertical scale" and "Vertical offset" are read-only. For FFT, only the "Vertical maximum" is read-only.

Vertical Scale ← Vertical Scale

Defines the scale of the y-axis in the math function diagram. The value is defined as "<unit> per division", e.g. *50m V/div*. In this case, the horizontal grid lines are displayed in intervals of 50 mV.

If the "[Vertical scale mode \(Manual/Auto\)](#)" on page 289 is set to "Auto", this setting is read-only.

Remote command:

[CALCulate:MATH<m>:VERTical:SCALE](#) on page 849

Vertical Offset ← Vertical Scale

Sets a voltage offset to adjust the vertical position of the math function on the screen. Negative values move the waveform up, positive values move it down.

If the "[Vertical scale mode \(Manual/Auto\)](#)" on page 289 is set to "Auto", this setting is read-only.

Remote command:

[CALCulate:MATH<m>:VERTical:OFFSet](#) on page 848

Arithmetic

Functions to specify the waveform arithmetic for the math waveforms.

Reset Now ← Arithmetic

Forces the immediate restart of the envelope and average calculation for all waveforms, ignoring the reset settings.

Remote command:

[ACQUIRE:ARESet:IMMEDIATE](#) on page 683

Acquisition/average count ← Arithmetic

Access:

- TRIGGER > "Control" tab > "Average count (N-single count)"
- ACQUISITION > "Average count"
- HORIZONTAL > "Ultra Segmentation" tab > disable "Acquire maximum" > "Required"
- MATH > "Setup" tab > "Average count"

The acquisition and average count has several effects:

- It sets the number of waveforms acquired with RUN N× SINGLE.
- It defines the number of waveforms used to calculate the average waveform. Thus, the instrument acquires sufficient waveforms to calculate the correct average if "Average" is enabled for waveform arithmetic. The higher the value is, the better the noise is reduced.
- It sets the number of acquisitions to be acquired in an Ultra Segmentation acquisition series. Thus, you can acquire exactly one Ultra Segmentation acquisition series with RUN N× SINGLE.
If Ultra Segmentation is enabled and configured to acquire the maximum number of acquisitions, the acquisition count is set to that maximum number and cannot be changed. See also: ["Number of acquisitions"](#) on page 115.
- It is the "Finished" criteria for the state of a mask test.

Remote command:

[ACQUIRE:COUNT](#) on page 683

Mode ← Arithmetic

Waveform arithmetic builds the resulting waveform from several consecutive acquisitions and subsequent math calculations of the signal. For details see ["Wfm Arithmetic"](#) on page 112.

"Original"	The original results are displayed
"Envelope"	The envelope curve of all acquired and calculated results is displayed
"Average"	The average of all acquired and calculated results is displayed
"RMS"	The root mean square of the math data is displayed. The result is the average power spectrum. If you measure the channel power on this RMS spectrum, you get the same result as for the average channel power measurement on waveforms.

Remote command:

[CALCulate:MATH<m>:ARITHmetics](#) on page 848

**Reset mode ← Arithmetic**

Defines when the envelope and average evaluation restarts.

- | | |
|--------|---|
| "None" | No restart, the number of acquisitions considered by the waveform arithmetics is not limited. |
|--------|---|



"Time" Restarts the envelope and average calculation after the time defined in "Reset time".



"Waveforms" Restarts the envelope and average calculation after a number of acquired waveforms defined in "Reset count".

Remote command:

[ACQUIRE:ARESet:MODE](#) on page 684

[ACQUIRE:ARESet:TIME](#) on page 684

[ACQUIRE:ARESet:WFMCOUNT](#) on page 684

8.2 Mathematical Functions and Formulas

You can enter mathematical expressions using two different modes:

- "Basic": a graphical editor allows you to define a simple math function quickly by selecting the source waveform(s) and the operator: [chapter 8.2.1, "Basic Editor"](#), on page 291.
- "Advanced": a formula editor allows you to define sophisticated math functions freely, as required to your needs: [chapter 8.2.2, "Advanced Expressions"](#), on page 293.

SCPI command:

- [CALCulate:MATH<m>\[:EXPRession\] \[:DEFine\]](#) on page 847

8.2.1 Basic Editor

In the basic editor, you can define the most common mathematical formulas without knowing their correct syntax.

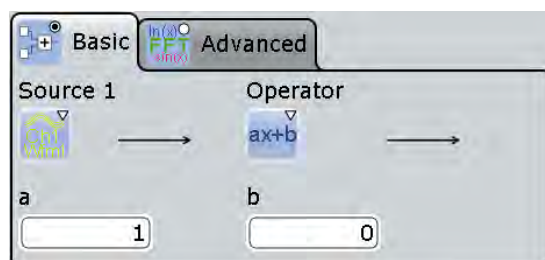

8.2.1.1 Defining a Formula in the Basic Editor

1. In the "Math" menu, select "Math Setup", or press the MATH key.
2. In the "Setup" tab, select the "Basic" tab.
3. Tap the "Source 1" and "Source 2" icons and select the signal source(s) to which the math function will be applied. For details on available signal sources, see ["Source 1 / 2"](#) on page 292.

4. Tap the "Operator" icon and select the mathematical function.
For details on available operators, see ["Operator"](#) on page 292.
5. If the operator requires additional parameters, enter them in the input fields.

8.2.1.2 Settings in the Basic Editor

Source 1 / 2.....	292
Operator.....	292
Noise reject.....	292
a / b.....	293
FIR: Type, Cut-Off.....	293

Source 1 / 2

Defines the signal source to be evaluated by the math function. Waveform 1 of each channel waveform can be selected.

Note: If you require other signal sources not listed here, use the formula editor provided in the "Advanced" tab. In advanced mode, any waveform of any input channel can be used as a source. See: [chapter 8.2.2, "Advanced Expressions"](#), on page 293.

Operator

Defines the type of operation to be performed on the selected signal sources. The following functions are available:

Note: If you require other operators not listed here, use the formula editor provided in the "Advanced" tab. See: [chapter 8.2.2, "Advanced Expressions"](#), on page 293.

"+"	Adds up the sources
"-"	Subtracts source 2 from source 1.
"x"	Multiplies source 1 by source 2.
" x "	Determines the absolute value of the source.
"dx/dt"	Differentiates the source value with respect to the time value.
"log(x)"	Calculates the logarithm of the source value based on 10.
"ln(x)"	Calculates the natural logarithm of the source value (based on e).
"ld(x)"	Calculates the binary logarithm of the source value (logarithmus dualis, based on 2).
"Rescale"	Rescales the source values by a factor a and an offset b: $ax+b$. See also: "a / b" on page 293.
"FIR filter"	Finite impulse response filter - highpass or lowpass filter for a specified cut-off frequency. See also: "FIR: Type, Cut-Off" on page 293.
"Mag(FFT(x))"	Determines the magnitude of the FFT for the source values.

Noise reject

In order to suppress noise effects during differentiation it can be useful not to consider two directly neighboring points to calculate dx (x_n-x_{n-1}), but rather to skip a number of samples inbetween and use a point a few samples further (e.g. x_n-x_{n-3}).

The number of samples shown here defines the number of neighboring samples that are skipped for differentiation.

Only available for the "dx/dt" operator.

a / b

Defines the values for the "Rescale" function (ax+b).

"a" is the factor the signal source is multiplied with

"b" is the offset of the signal source on the y-axis

FIR: Type, Cut-Off

The Finite Impulse Response filter ("Operator" = FIR) is a Gauss filter that requires two additional settings:

- "Type": defines whether the FIR filter is a highpass or lowpass filter.
- "Cut-Off": sets the limit frequency for the FIR filter.

The cut-off frequency depends on the horizontal resolution. The frequency for the lowpass filter can be set only in this range:

$$f_{g_3dB} = (0.0025 \dots 0.1) * f_{a_in}$$

Where: f_{g_3dB} = cut-off frequency to be set for the lowpass filter, and f_{a_in} = reciprocal of the resolution, or sample rate.

To check limit frequency for the highpass filter, convert it to an equivalent lowpass frequency:

$$f_{TP} = f_{a_in}/2 - f_{HP}$$

Where f_{HP} is the requested highpass limit frequency and f_{TP} the equivalent lowpass frequency that has to comply with the limits given above.

For advanced expression, see [table 8-10](#).

8.2.2 Advanced Expressions

In the "Advanced" tab, you can enter complex formulas to define a math waveform. The formula editor helps to enter formulas easily with correct syntax, using a large selection of operators and signal sources. Double-tap the "Advanced" tab to display the formula editor.



8.2.2.1 Defining a Formula in the Advanced Formula Editor

1. In the "Math" menu, select "Math Setup".

2. In the "Setup" tab, select the "Advanced" tab.
3. Double-tap the editing area.
The "Formula Editor" is displayed.
4. Enter the math formula including all required signal sources and operators by selecting the corresponding keys in the editor. For details on the available keys, see [chapter 8.2.2.2, "Advanced Formula Editor"](#), on page 294.
5. To insert a physical unit in the formula, proceed as follows:
 - a) If necessary, insert a decimal prefix using the "M/k/μ" key.
 - b) Insert an opening square bracket using the "[" key.
 - c) Insert the physical unit using the "V/A/Ω" key.
 - d) Insert a closing square bracket using the "]" key.The resulting expression could be, for example: `m[V]`
6. To perform a rescaling function, proceed as follows:
 - a) Select the rescaling function using the "ax+b" key.
 - b) Behind the left bracket, insert the signal source that is to be rescaled using one of the following keys:
 - "Ch" for a channel
 - "Math" for a math function
 - "Ref" for a reference waveform
 - "Meas" for a measurement
 - c) Insert a comma using the "," key.
 - d) Insert the "a" value, i.e. the scaling factor, using the number keys.
 - e) Insert a comma using the "," key.
 - f) Insert the "b" value, i.e. the scaling offset, using the number keys.
 - g) Insert the closing bracket using the ")" key.The resulting expression could be, for example: `rescale(Ch1Wfm1,3,4)`

8.2.2.2 Advanced Formula Editor

Using the formula editor you can define math functions freely, using a large selection of operators and signal sources. For a procedure on using the editor, see [chapter 8.2.2.1, "Defining a Formula in the Advanced Formula Editor"](#), on page 293.



The following tables describe the buttons of the formula editor and their usage.

Table 8-1: Basics

Icon	Description	Usage/Comment, <i>FormulaEditor</i> expression
(left bracket	enclose operands
,	comma	separates operands
)	right bracket	enclose operands
e / π	math. constants	e: Euler number: 2.7182... Pi: 3.1415...
[left square bracket	enclose unit
V / A / Ω	units	[<unit>]
]	right square bracket	enclose unit
x ^a	exponentiation with base x	x: base, a: exponent x ^a
/	division	
*	multiplication	
-	subtraction	
+	addition	
0...9	numeric characters	
.	decimal point	
Exp	exponentiation with base 10	e
Enter	expression complete	insert expression in Setup dialog and close the formula editor

Icon	Description	Usage/Comment, <i>FormulaEditor</i> expression
Clear	clear expression in editor	restart editing
Del	Delete	remove selected part of expression
Back	Backspace	remove last symbol, operator or operand to the left of the cursor
M / k / μ	SI-prefix for unit	<SI-prefix>[<unit>]

Table 8-2: Signal sources

Icon	Description	Usage/Comment, <i>FormulaEditor</i> expression
Ch	signal waveform	<i>Ch</i> <1...4> <i>Wfm</i> <1...3>
Math	math waveform	<i>Math</i> <1...4>
Ref	reference waveform	<i>Ref</i> <1...4>
Meas	measurement waveform	<i>Meas</i> <1...8>

Table 8-3: Cursor keys

Icon	Description	Usage/Comment, <i>FormulaEditor</i> expression
←	move cursor to beginning	
←	move cursor 1 step to the left	
→	move cursor 1 step to the right	
→	move cursor to end	

Table 8-4: Algebra

Icon	Description	Usage/Comment, <i>FormulaEditor</i> expression
x	absolute x value	<i>abs(x)</i>
\sqrt{x}	square root of x	<i>sqrt(x)</i>
x^2	$x*x$	<i>pow(x)</i>
\log_{10}	common logarithm (base 10)	<i>log(x)</i>
\log_e	natural logarithm (base e)	<i>ln(x)</i>
\log_2	binary logarithm (base 2)	<i>ld(x)</i>
e^x	exponentiation with base e	<i>exp(x)</i>
$\int x dx$	integral of x	<i>integral(x)</i>
d/dx	derivation of x	<i>derivation(x)</i>
ax+b	scaling of x	<i>rescale(x,a,b)</i>

Table 8-5: Bit operations

Icon	Description	Usage/Comment, <i>FormulaEditor</i> expression
digitize	convert to 0 or 1	<i>digitize(x)</i>
not	negation	<i>not(x)</i>
and		<i>and</i>
nand	negation of and	<i>nand</i>
or		<i>or</i>
nor	negation of or	<i>nor</i>
xor	exclusive or	<i>xor</i>
nxor	negation of exclusive or	<i>nxor</i>

Table 8-6: Comparison

Icon	Description	Usage/Comment, <i>FormulaEditor</i> expression
=	equal	=
≠	not equal	<>
<	smaller	<
>	greater	>
≤	smaller or equal	<=
≥	greater or equal	>=
More	display additional keys	

Table 8-7: FFT ("More" keys)

Icon	Description	Usage/Comment, <i>FormulaEditor</i> expression
FFT	magnitude of FFT value	<i>fftmag(x)</i>
FFT (φ)	FFT phase value	<i>fftphi(x)</i>
FFT -dφ*df	FFT group delay	<i>fftgroupdelay(x)</i>
FFT (re)	real part of FFT value	<i>fftre(x)</i>
FFT (im)	imag part of FFT value	<i>fftim(x)</i>

Table 8-8: Trigonometry ("More" keys)

Icon	Description	Usage/Comment, <i>FormulaEditor</i> expression
sinh	hyperbolic sinus	<i>sinh(x)</i>
cosh	hyperbolic cosinus	<i>cosh(x)</i>
tanh	hyperbolic tangens	<i>tanh(x)</i>

Table 8-9: Correlation ("More" keys)





Icon	Description	Usage/Comment, <i>FormulaEditor</i> expression
	cross correlation function of two waveforms Measures the similarity of two waveforms as a function of a time-lag applied to one of them Function limits the maximum record length to 4 MSa	<i>correlation(x1, x2)</i> with x1 = waveform 1 and x2 = waveform 2
	auto correlation Used to find repeating patterns, for example, a periodic signal obscured by noise	<i>autocorrelation(x)</i>
	biased / unbiased correlation	<i>biased(x) / unbiased(x)</i>

Table 8-10: Filter and power ("More" keys)

Icon	Description	Usage/Comment, <i>FormulaEditor</i> expression
	Electric power	Electric power is calculated from voltage, based on measurement impedance (see " Measurement impedance " on page 119) <i>elecpower(x) = U²/R</i>
FIR	Finite impulse response filter	<i>FIR(highpass,x,y)</i> or <i>FIR(lowpass,x,y)</i> with: x = source, y = cut-off frequency Example: <i>FIR(lowpass,Ch1Wfm1,2.5e+007)</i> sets a lowpass filter with 25 MHz cut-off frequency See also: " FIR: Type, Cut-Off " on page 293.
	parameter for FIR filter	<i>highpass / lowpass</i>

8.3 FFT Analysis

8.3.1 Fundamentals of FFT Analysis

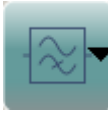
During FFT analysis, a signal in the time domain is converted to a spectrum of frequencies. As a result, either the magnitude or the phase of the determined frequencies can be displayed. FFT analysis can be restricted to an extract of the original time base, and the results display can be restricted to a specified frequency range.

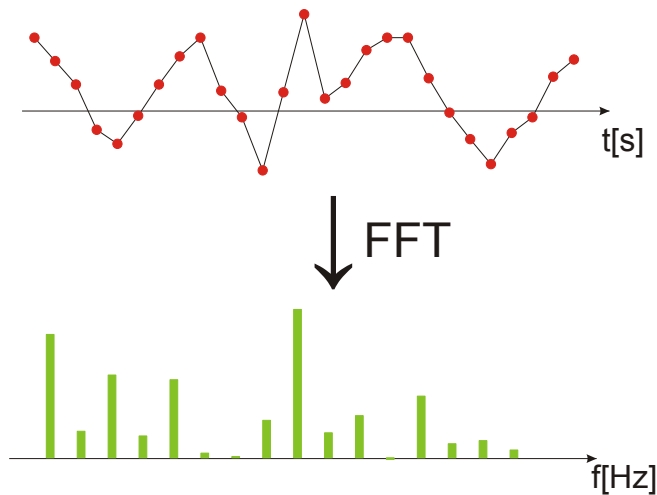

Frames

In order to convert the time domain signal to a frequency spectrum, an FFT (Fast Fourier Transformation) unit is used which converts a vector of input values into a discrete spectrum of frequencies.

Conventional oscilloscopes calculate one FFT per capture. The R&S RTO can calculate multiple FFTs per capture by dividing one capture into several frames. Thus, the RTO can visualize how the frequency content of a signal changes over time which helps to detect intermittent or sporadic signal details. Furthermore, the R&S RTO allows consecutive frames to overlap. This is especially useful in conjunction with window functions since it enables a gap-free frequency analysis of the signal.

The overlapping factor can be set freely. The higher the overlap factor, the more frames are used. This leads to more individual results and improves detection of transient signal effects. However, it also extends the duration of the calculation. The size of the frame depends on the number of input signal values (record length), the overlap factor, and the FFT size (number of samples used for FFT calculation).

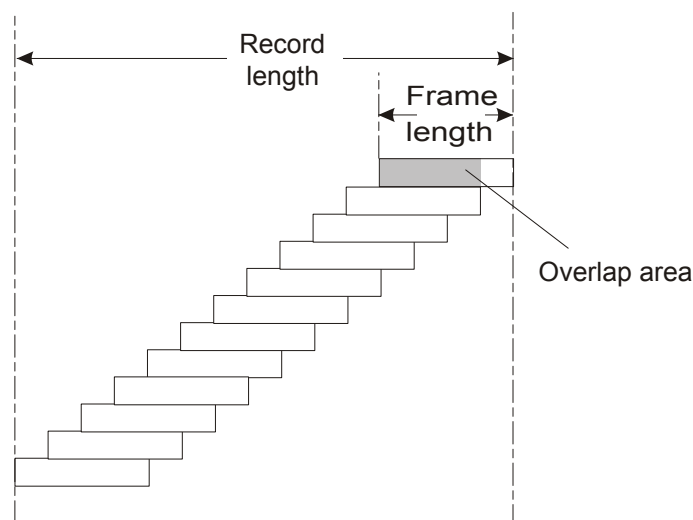

Window functions

Each frame is multiplied with a specific window function after sampling in the time domain. Windowing helps minimize the discontinuities at the end of the measured signal interval and thus reduces the effect of spectral leakage, increasing the frequency resolution.

There are a number of window functions that can be used in FFT analysis. Each of the window functions has specific characteristics, including some advantages and some trade-offs. These characteristics need to be considered carefully to find the optimum solution for the measurement task.

For details, see "[Window type](#)" on page 308.

Gating functions

You can restrict the time base of the input signal for which FFT analysis is to be performed. There are various methods to do so:

- Define absolute start and stop times for the time base extract
- Define relative start and stop values that define a percentage of the original time base
- Couple the time base extract for FFT to an active zoom area.

The gate area can be indicated in the signal diagram, if desired.

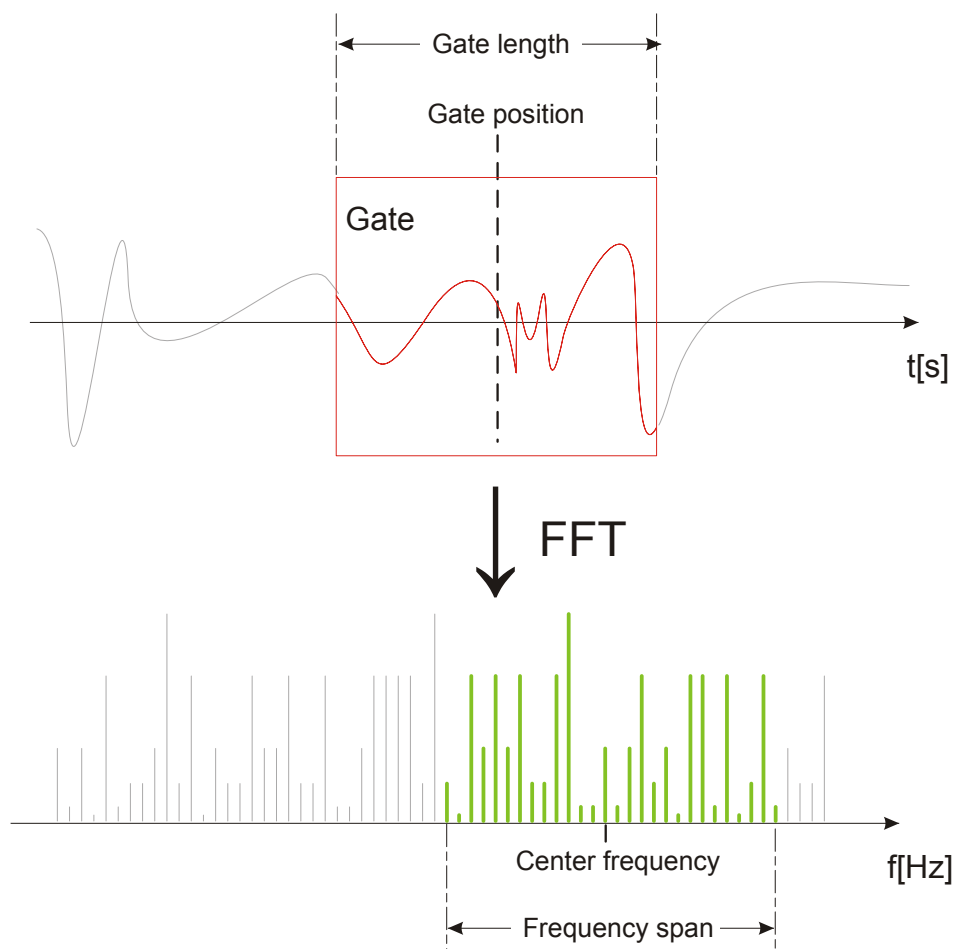

Restricting the result range

You can restrict the results of the FFT analysis to a specified frequency range. The frequency range can be defined in two ways:

- Define a center frequency and frequency span
- Define start and stop frequencies

Magnitude vs. phase display

The result of an FFT analysis is a spectrum of frequencies. Either the magnitudes or the phases of those frequencies are displayed, depending on the used FFT function. In "Basic" mode, and for the "Advanced" mode FFT functions $|FFT|$, $FFT(re)$ and $FFT(im)$, the magnitude is displayed. For the "Advanced" mode $FFT(\varphi)$ function, the phase is displayed.

For magnitude display, you can select the scale and range of magnitudes to be displayed. For linear scaling, the vertical value range of the input signal is used. For logarithmic scaling, the logarithmic power of the frequency is displayed. In this case, the input signal must be given in either Volt or Watt. The resulting value range is defined

by a maximum value and a range size. Logarithmic scaling can also be set in relation to a given reference value.

For phase display, you can select the unit and suppress phases beneath a threshold value which are most likely caused by noise. The value range $[-\pi, +\pi]$ or $[-180^\circ, +180^\circ]$ is used. Phase shifts due to a limitation of the value range can be eliminated using the "Unwrap" function.

Dependencies between FFT parameters

FFT analysis in the R&S RTO is highly configurable. Several parameters, including the resolution bandwidth, frequency span and center frequency, can be defined according to the user's requirements. Note, however, that several parameters are correlated and not all can be configured independently of the others.

The **resolution bandwidth** defines the minimum frequency separation at which the individual components of a spectrum can be distinguished. Small values result in a high precision, as the distance between two distinguishable frequencies is small. Higher values decrease the precision, but increase measurement speed.

The minimum achievable RBW is dependent on the integration time which is equivalent to the number of samples available for FFT calculation. If a higher spectral resolution is required the number of samples must be increased by using a higher sample rate or longer record length. To simplify operation some parameters are coupled and automatically calculated, such as record length and RBW.

The **frequency span** and **center frequency** define the start and stop frequency of the spectral diagram. By default, a suitable frequency range according to the resolution bandwidth is selected, in respect to performance and precision. Span and RBW settings are coupled, so that the parameters can be adjusted automatically as necessary.

With a **Span/RBW ratio** of 100 and a screen resolution of 1000 pixels, each frequency in the spectrum is displayed by 10 pixels. A span/RBW ratio of 1000 provides the highest resolution. For full flexibility the span/RBW coupling can also be disabled. Note, however, that a higher span/RBW ratio (i.e. low RBW values and large frequency spans) result in large amounts of data and extend the duration of the calculation.

Advanced FFT functions

In "Advanced" math definition mode, other FFT results than the basic frequency magnitude can be displayed.

- **FFT (ϕ)**: phase display
- **FFT (**im**)**: imaginary part of FFT value (magnitude)
- **FFT (**re**)**: real part of FFT value (magnitude)
- **FFT $-\mathbf{d}\phi*\mathbf{d}f$** (group delay): the negative derivative of the phase with respect to frequency; useful to measure phase distortion

8.3.2 Configuring FFT Waveforms

During FFT analysis, a signal in the time domain is converted to a spectrum of frequencies. A basic FFT waveform can be displayed very quickly. By defining additional FFT parameters, the waveform can be configured in more detail.

As a result, either the magnitude or the phase of the determined frequencies can be displayed, or more complex FFT functions. Analysis can be restricted to an extract of the original time base, and the results display can be restricted to a specified frequency range.

To display a basic FFT waveform

1. Tap the "FFT" icon on the toolbar, then tap the waveform for which the FFT is to be performed.



The first available math waveform is configured to use the selected waveform as a source and the "Mag(FFT(x))" operator and is enabled. The FFT waveform is displayed in a new diagram.

2. Alternatively, press the MATH key to open the "Math" dialog box.
3. In the "Setup" tab, in the "Basic" editor, select the input signal as "Source 1".
4. Select "Mag(FFT(x))" as the "Operator".
5. Select the "Enable math signal" icon.
6. If required, edit the FFT waveform parameters as described in ["To configure the FFT setup"](#) on page 303.

To configure the FFT setup

1. Select the "FFT Setup" tab of the "Math" dialog box.
2. By default, a suitable frequency range for the expected horizontal values according to the resolution bandwidth is selected, in respect to performance and precision. Span and RBW settings are coupled. If a more precise evaluation is required, for example for postprocessing in a different application, disable the coupling and change the frequency ranges and resolution bandwidth values as required.
 - a) Disable the "Span/RBW coupling".
 - b) Specify the frequency range to be displayed using one of the following methods:
 - Enter a "Center frequency" and a "Frequency span" that define the spectrum.
 - Enter a "Start frequency" and "Stop frequency" that define the spectrum.
 - Tap the "Full Span" button to display the complete spectrum resulting from the FFT analysis.

- c) Change the "Span/RBW ratio". The smaller the ratio, the higher the RBW becomes to display the same frequency span.
 - d) Define the resolution bandwidth for the FFT result.
The resolution bandwidth defines how precise the results are, i.e. how close together the individual frequencies can be. Small values result in a high precision, as the distance between two distinguishable frequencies is small. Higher values decrease the precision, but increase performance.
3. Select the most suitable "Window type" for your source data. Window functions are multiplied with the input values and thus can improve the FFT display. For details, see "[Window type](#)" on page 308.
 4. Select an arithmetic mode for the FFT frames. This mode defines how the individual frame results are combined to a final FFT waveform.
 5. Select an overlap factor for neighboring frames.
The higher the overlap factor, the more frames are used. This leads to more individual results and improves detection of transient signal effects. However, it also extends the duration of the calculation.

To configure magnitude results

1. Open the "FFT Magnitude/Phase" tab of the "Math" dialog box.
2. Select the scaling unit. Use logarithmic scaling only for input values in Volt or Watt.
3. Decide whether you want to configure the value range manually or use the automatic settings by tapping the corresponding icon.
4. In manual mode, define the size of the "Vertical range" and the "Vertical maximum" to be displayed.
5. In automatic mode, define the size of the "Range" to be displayed.
6. For logarithmic scaling in dB, also define the "Reference level" to be used.

To configure phase results

1. Open the "FFT Magnitude/Phase" tab of the "Math" dialog box.
2. Select the scaling unit.
3. To eliminate phase shifts due to a limitation of the value range, enable the "Unwrap" function.
4. To suppress small phase values due to noise, enable the "Suppression" function and enter a "Threshold" value.

To restrict the input values (gating)

1. In the "FFT Gating" tab of the "Math" dialog box, define the gate area, i.e. the extract of the time base in the original diagram for which the FFT analysis is to be performed. To do so, use one of the following methods:

- Select the "Absolute" mode and enter the "Start" and "Stop" times that define the gate area.
 - Select the "Relative" mode and enter the percentages of the total time base that define the "Relative Start" and "Relative Stop" times.
 - If a zoom area has already been defined in the original diagram and you want to use the same time base for FFT analysis, select "Zoom coupling" and then an active zoom diagram.
2. Tap the "Use gate" icon.
 3. To indicate the defined gate area in the original diagram, tap the "Show gate" icon.
The FFT waveform displays the spectrum for the indicated area in the original time base.

To display advanced FFT waveforms

In "Advanced" math definition mode, other FFT results than the basic frequency magnitude can be displayed.

1. In the "Setup" tab of the "Math" dialog box, select the "Advanced" expression editor.
2. Double-tap the edit area.
The "FormulaEditor" is displayed.
3. Tap the "More" key to display further functions in the editor.
4. Tap the required function key.
5. Select the source channel.
6. Close the parenthesis and tap "Enter".

8.3.3 FFT Configuration Settings

8.3.3.1 FFT Setup

In this tab you define the settings for the FFT window. The display can be restricted to the results for a certain time base extract and to a specified frequency range.

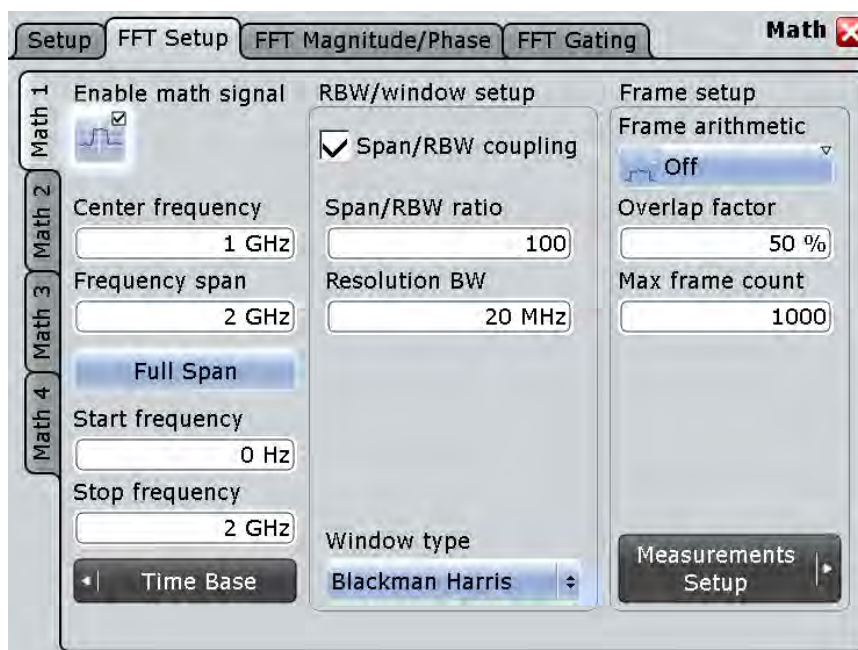

Enable Math Signal..... 306

Center frequency..... 306

Frequency span..... 307

Full span..... 307

Start frequency..... 307

Stop frequency..... 307

Span/RBW Coupling..... 307

Span/RBW Ratio..... 307

Resolution BW..... 308

Window type..... 308

Frame Arithmetics..... 308

Overlap Factor..... 309

Max frame count..... 309

Frame coverage..... 309

Enable Math Signal

If activated, a diagram for the defined math waveform is displayed on the touch screen.

Remote command:

[CALCulate:MATH<m>:STATe](#) on page 847

Center frequency

Defines the position of the displayed frequency range, which is (Center - Span/2) to (Center + Span/2). The width of the range is defined using the "Frequency span" setting.

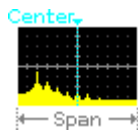

Remote command:

[CALCulate:MATH<m>:FFT:CFrequency](#) on page 852

Frequency span

The span is specified in Hertz and defines the width of the displayed frequency range, which is (Center - Span/2) to (Center + Span/2). The position of the span is defined using the "Center frequency" setting.

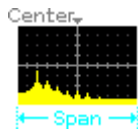

Remote command:

[CALCulate:MATH<m>:FFT:SPAN](#) on page 853

Full span

Displays the full frequency span.

Remote command:

[CALCulate:MATH<m>:FFT:FULLspan](#) on page 853

Start frequency

Defines the start frequency of the displayed frequency span.

Remote command:

[CALCulate:MATH<m>:FFT:START](#) on page 850

Stop frequency

Defines the stop frequency of the displayed frequency span.

Remote command:

[CALCulate:MATH<m>:FFT:STOP](#) on page 850

Span/RBW Coupling

Couples the frequency span to the "Resolution BW" setting.

Remote command:

[CALCulate:MATH<m>:FFT:BANDwidth\[:RESolution\]:AUTO](#) on page 854

Span/RBW Ratio

Defines the coupling ratio for Span/RBW. This setting is only available if [CALCulate:MATH<m>:FFT:BANDwidth\[:RESolution\]:AUTO](#) is ON.

Remote command:

[CALCulate:MATH<m>:FFT:BANDwidth\[:RESolution\]:RATio](#) on page 854

Resolution BW

Defines the resolution bandwidth. Note that the resolution bandwidth is correlated with the span, record length and acquisition time. If a constant record length is to be used, the RBW may be adapted if the required number of samples cannot be acquired. If span and RBW values are coupled, changing the span will also change the RBW.

For details see [chapter 8.3.1, "Fundamentals of FFT Analysis"](#), on page 298.

Remote command:

`CALCulate:MATH<m>:FFT:BANDwidth[:RESolution][:VALue]` on page 854

`CALCulate:MATH<m>:FFT:BANDwidth[:RESolution]:ADJusted?` on page 853

Window type

Windowing helps minimize the discontinuities at the end of the measured signal interval and thus reduces the effect of spectral leakage, increasing the frequency resolution.

Various different window functions are provided in the R&S RTO to suit different input signals. Each of the window functions has specific characteristics, including some advantages and some trade-offs. These characteristics need to be considered carefully to find the optimum solution for the measurement task.

Window type	Frequency resolution	Magnitude resolution	Measurement recommendation
Rectangular	Best	Worst	Separation of two tones with almost equal amplitudes and a small frequency distance
Hamming Hann	Good	Poor	Frequency response measurements, sine waves, periodic signals and narrow-band noise
Blackman Harris (default)	Worst	Best	Mainly for signals with single frequencies to detect harmonics Accurate single-tone measurements
Gaussian	Good	Good	Weak signals and short duration
Flattop2	Poor	Best	Accurate single-tone measurements
Kaiser Bessel	Poor	Good	Separation of two tones with differing amplitudes and a small frequency distance

Remote command:

`CALCulate:MATH<m>:FFT:WINDow:TYPE` on page 851

Frame Arithmetics

FFT analysis can only be performed on a maximum number of values at once. If more values must be calculated, the input signal is divided into frames, each of which is calculated separately. The frames need not be disjunct, i.e. they may overlap, so that some values have several FFT results. In this case, the arithmetic mode defines how the final result is calculated from the individual results.

The following methods are available:

"Off" The data of only one frame is taken into consideration. In effect, no arithmetics are processed.

"Envelope"	Detects the minimum and maximum values for FFT calculation over all frames. The resulting diagram shows two envelope waveforms: the minimums (floor) and maximums (roof). These envelopes indicate the range of all FFT values that occurred.
"Average"	The average is calculated over all frames.
"RMS"	The root mean square is calculated over all frames. The result is the average power spectrum. If you measure the channel power on this RMS spectrum, you get the same result as for the average channel power measurement on frames.

Remote command:

[CALCulate:MATH<m>:FFT:FRAME:ARITHmetics](#) on page 855

Overlap Factor

Defines the minimum factor by which two neighboring frames overlap. If the required number of frames to cover the input values allows for more overlap, the factor is increased.

The higher the overlap factor, the more frames are used. This leads to more individual results and improves detection of transient signal effects. However, it also extends the duration of the calculation.

Remote command:

[CALCulate:MATH<m>:FFT:FRAME:OFACTOR](#) on page 856

Max frame count

Restricts the maximum number of frames to be calculated. Due to the other parameter settings, the required number of frames may become very high, thus slowing performance. By restricting the number of frames, you can avoid performance loss without changing the other parameters.

Remote command:

[CALCulate:MATH<m>:FFT:FRAME:MAXCOUNT](#) on page 856

Frame coverage

Due to the [Max frame count](#) restriction, the waveform may only be analyzed partially. The "Frame coverage" indicates the percentage of the trace that was analyzed, i.e. which part of the trace was included in the frame calculation.

Remote command:

[CALCulate:MATH<m>:FFT:FRAME:COVERAGE?](#) on page 856

8.3.3.2 FFT Magnitude/Phase

In this tab you define the settings for the magnitude and phase of the frequencies.

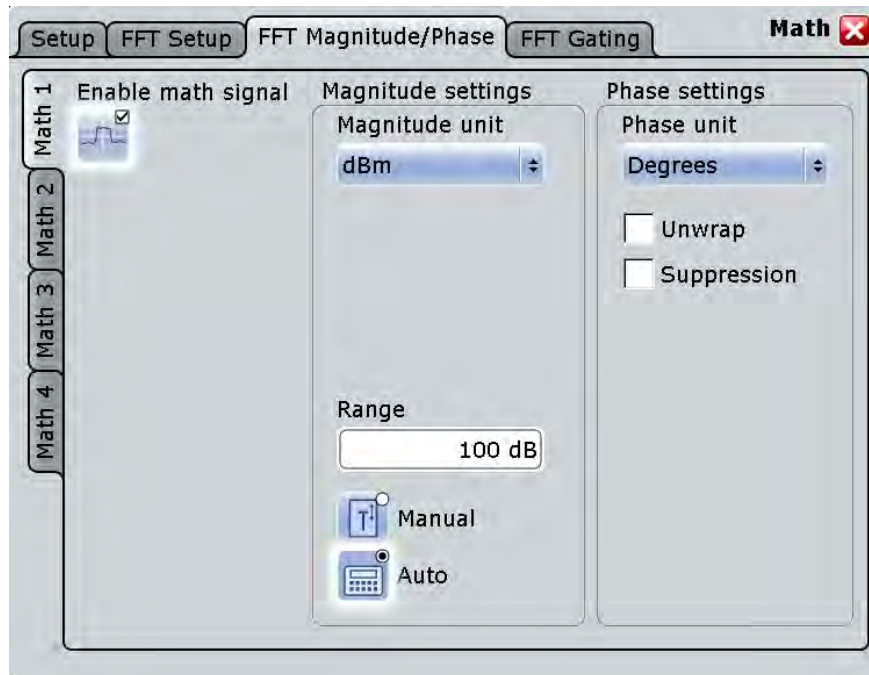

Enable Math Signal.....	310
Magnitude unit.....	310
Reference level.....	311
Vertical scale mode (Manual/Auto).....	311
Vertical maximum.....	311
Vertical range.....	311
Range.....	311
Phase unit.....	311
Unwrap.....	312
Suppression.....	312
Threshold.....	312

Enable Math Signal

If activated, a diagram for the defined math waveform is displayed on the touch screen.

Remote command:

`CALCulate:MATH<m>:STATe` on page 847

Magnitude unit

Defines the scaling of the y-axis. The display values are valid for 50Ω termination impedance.

"Linear"	linear scaling; displays the RMS value of the voltage
"dBm"	logarithmic scaling; related to 1 mW
"dB"	logarithmic scaling; related to reference level
"dBμV"	logarithmic scaling; related to 1 μV
"dBmV"	logarithmic scaling; related to 1 mV
"dBV"	logarithmic scaling; related to 1 V
"dBps"	logarithmic scaling; related to 1 ps

"dBns"	logarithmic scaling; related to 1 ns
"dB μ s"	logarithmic scaling; related to 1 μ s
"dBms"	logarithmic scaling; related to 1 ms
"dBs"	logarithmic scaling; related to 1 s

Remote command:

[CALCulate:MATH<m>:FFT:MAGNitude:SCALE](#) on page 860

Reference level

Defines the reference level for dB scaling.

Remote command:

[CALCulate:MATH<m>:FFT:MAGNitude:LEVel](#) on page 859

Vertical scale mode (Manual/Auto)

By default, the vertical scale is adapted to the current measurement results automatically to provide an optimal display. However, if necessary, you can define scaling values manually to suit your requirements.

Note: When you change the scaling values manually using the "Scale" rotary knob, the scale mode is set to "Manual" temporarily. When you edit the math function, scaling is automatically set back to "Auto" mode. "Manual" mode is only maintained during math function changes if you select it yourself.

"Manual"	Enter the required values for "Vertical scale" and "Vertical offset". For FFT, set "Vertical range" and "Vertical maximum".
"Auto"	"Vertical scale" and "Vertical offset" are read-only. For FFT, only the "Vertical maximum" is read-only.

Vertical maximum

Defines the maximum value on y-axis for spectrum displays. Only available for "Manual" scale mode.

Vertical range

Defines the range of FFT values to be displayed.

Remote command:

[CALCulate:MATH<m>:VERTical:RANGe](#) on page 849

Range

Defines the vertical value range in spectrum mode.

Remote command:

[CALCulate:MATH<m>:FFT:MAGNitude:RANGe](#) on page 859

Phase unit

Defines the scaling unit for phase display.

- Radians
- Degrees

Remote command:

[CALCulate:MATH<m>:FFT:PHASe:SCALE](#) on page 860

Unwrap

If enabled, phase shifts due to a limitation of the value range are eliminated.

Remote command:

[CALCulate:MATH<m>:FFT:PHASe:UNWRap](#) on page 861

Suppression

Enables noise suppression. Phase calculation is restricted to frequencies with a minimum magnitude, the threshold value.

Remote command:

[CALCulate:MATH<m>:FFT:PHASe:SUPPReSSion](#) on page 860

Threshold

Defines the minimum frequency magnitude for which phases are calculated. This setting is only available if "Suppression" is enabled.

Remote command:

[CALCulate:MATH<m>:FFT:PHASe:THReShold](#) on page 861

8.3.3.3 FFT Gating

FFT gating allows you to restrict FFT analysis to a certain time base of the input signal.

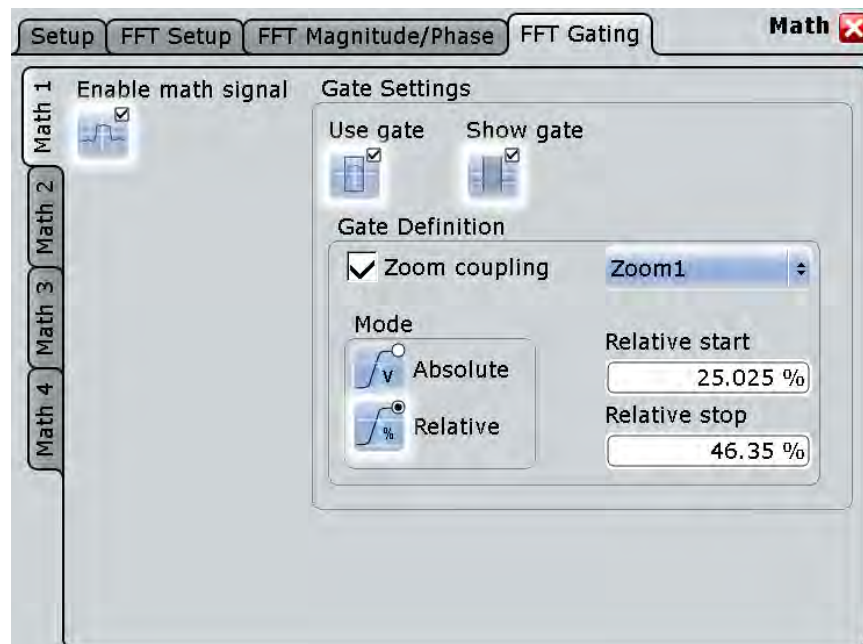

If no gate is used, you can define the type of "Record Length/RBW Coupling" here.

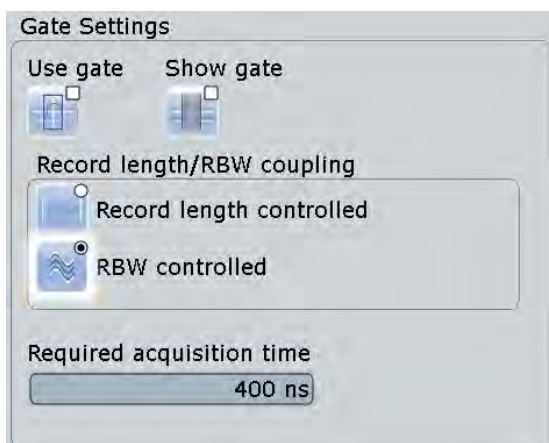

Enable Math Signal..... 313

Use Gate..... 313

Show gate..... 313

Gate Definition..... 313

 L Zoom coupling..... 314

 L Mode..... 314

 L (Relative) Start..... 314

 L (Relative) Stop..... 314

Record Length/RBW Coupling..... 315

Required acquisition time..... 315

Enable Math Signal

If activated, a diagram for the defined math waveform is displayed on the touch screen.

Remote command:

[CALCulate:MATH<m>:STATe](#) on page 847

Use Gate

Enables FFT gating.

If enabled, the "Gate Definition" settings are displayed. If disabled, record length and RBW settings are displayed.

When a gate is used, the RBW is adapted, if necessary. The smaller the gate, the higher the RBW.

For details see [chapter 8.3.1, "Fundamentals of FFT Analysis"](#), on page 298.

Show gate

Displays the gate area in the source diagram.

Remote command:

[CALCulate:MATH<m>:FFT:GATE:SHOW](#) on page 858

[MEASurement<m>:GATE:SHOW](#) on page 845

[SEARCh:GATE:SHOW](#) on page 904

Gate Definition

Defines the gate settings for FFT gating.

Zoom coupling ← Gate Definition

Zoom coupling is available if a zoom is defined. As long as "Zoom coupling" is enabled, the gate area is defined identically to the zoom area - if you change the zoom, the gate changes as well.

If several zoom diagrams are defined, select the zoom diagram to be used for gating. The "Start" and "Stop" values of the gate are adjusted accordingly.

Zoom coupling can be set for measurement gates, FFT gates, and search gates.

Remote command:

[CALCulate:MATH<m>:FFT:GATE:ZCOupling](#) on page 858

[MEASurement<m>:GATE:ZCOupling](#) on page 845

[SEARch:GATE:ZCOupling](#) on page 905

[SEARch:GATE:ZDIagram](#) on page 905

Mode ← Gate Definition

Defines whether the gate settings are configured using absolute or relative values.

"Absolute" The gate is defined by absolute start and stop values.

"Relative" The gate's start and stop values are defined by a percentage of the value range.

Remote command:

[CALCulate:MATH<m>:FFT:GATE:MODE](#) on page 857

[MEASurement<m>:GATE:MODE](#) on page 844

[SEARch:GATE:MODE](#) on page 904

(Relative) Start ← Gate Definition

Defines the starting value for the gate.

Remote command:

[CALCulate:MATH<m>:FFT:GATE:ABSolute:START](#) on page 857

[CALCulate:MATH<m>:FFT:GATE:RELative:START](#) on page 858

[MEASurement<m>:GATE:ABSolute:START](#) on page 844

[MEASurement<m>:GATE:RELative:START](#) on page 844

[SEARch:GATE:ABSolute:START](#) on page 904

[SEARch:GATE:RELative:START](#) on page 905

(Relative) Stop ← Gate Definition

Defines the end value for the gate.

Remote command:

[CALCulate:MATH<m>:FFT:GATE:ABSolute:STOP](#) on page 857

[CALCulate:MATH<m>:FFT:GATE:RELative:STOP](#) on page 858

[MEASurement<m>:GATE:ABSolute:STOP](#) on page 844

[MEASurement<m>:GATE:RELative:STOP](#) on page 844

[SEARch:GATE:ABSolute:STOP](#) on page 904

[SEARch:GATE:RELative:STOP](#) on page 905

Record Length/RBW Coupling

The record length and resolution bandwidth are coupled during FFT analysis. If you change one value, the other must be adapted accordingly. You can keep either value constant, thus preventing automatic adaptation when the other parameter is changed. However, this may cause the FFT analysis to fail.

For details see [chapter 8.3.1, "Fundamentals of FFT Analysis"](#), on page 298.

"Record length controlled" The record length remains constant. If not enough samples are available for the selected RBW, the RBW will be decreased.

"RBW controlled" The RBW is not adapted, i.e. remains as defined by the user. The required acquisition time for this RBW is indicated. If necessary and possible, the record length is extended to acquire the required number of samples.

Remote command:

[CALCulate:MATH<m>:FFT:GATE:COUPLing](#) on page 854

Required acquisition time

The required acquisition time is calculated for the defined RBW value if "RBW constant" is selected, and is displayed for information only. If the required acquisition time is not available (e.g. because acquisition has already been stopped), an error message is displayed in the "FFT Setup" tab indicating that not enough samples are available for the defined RBW.

Remote command:

[TIMEbase:RACTime?](#) on page 855

9 Mask Testing

9.1 About Mask Testing

Masks are used to determine whether the signal remains within specified limits, e.g. to uncover signal anomalies or test compliance and stability of digital signals. The limits are specified as "mask", which is laid over the input signal in the display. Thus you can easily detect where the signal violates the mask.

Mask testing with R&S RTO has only a minor impact on the acquisition rate, thus mask violations are detected very fast and reliably.

With R&S RTO, you can define own masks easily. Specific actions can be executed when mask violations occur. For error analysis, you can stop the acquisition on a failed test and use the history view to look at the previous waveforms.

Mask test

A mask test consists of:

- Mask definition
- Waveform to be tested
- Fail criteria for test
- Actions to be taken on violation or successful completion

Mask Definition

A mask can be created in several ways:

- The individual mask points are defined, either on the touch screen or as numerical values. This mask type is called *user mask*.
For details, see [chapter 9.3.2.1, "Mask Definition: User Mask"](#), on page 328.
- The mask is derived from an existing waveform. This mask type is called *waveform mask*.
For details, see [chapter 9.3.2.2, "Mask Definition: Waveform Mask"](#), on page 331.

Fail Criteria for Testing

The fail criteria for a mask test is set by two parameters: "Fail condition" and "Violation tolerance". Fail condition defines if sample hits or the number of acquisitions with sample hits are considered. Violation tolerance sets the number of tolerable sample hits or acquisition hits. A test has failed if the number of sample hits or acquisition hits exceeds the limit of violation tolerance hits.

See also: ["Fail condition, Violation tolerance"](#) on page 327.

9.1.1 Results of a Mask Test

The result box of a mask test shows the following test results:

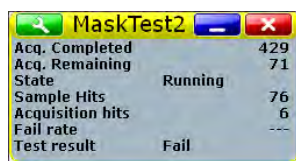

MaskTest2	
Acq. Completed	429
Acq. Remaining	71
State	Running
Sample Hits	76
Acquisition hits	6
Fail rate	---
Test result	Fail

Acq. completed

Number of tested acquisitions.

Remote command:

[MTESt:RESult:COUNT:WAVeforms?](#) on page 876

Acq. remaining

Remaining acquisitions until "Average count / Nx Single count" is reached.

The value is useful if you test a specified number of acquisitions with action "Stop acquisition" on violation, or if the acquisition has been stopped manually before the required number of acquisitions has been acquired.

See also: [chapter 9.2.4, "Running a Mask Test"](#), on page 324.

Remote command:

[MTESt:RESult:COUNT:REMaining?](#) on page 876

State

Shows if the test has been completed. The state is set to "Finished" when "Nx Single count" acquisitions are tested and the number of "Acq. remaining" is 0. as long as the number of tested acquisitions is less the "Nx Single count" number, the state is "Running".

If you run the acquisition with RUN CONT, or the number of played history acquisitions exceeds "Nx Single count", the mask testing is performed according to fail criteria settings independently of the test state. The testing is not stopped when the state is set to "Finished".

Remote command:

[MTESt:RESult:STATe?](#) on page 876

Sample hits

Number of samples that hit the mask.

Remote command:

[MTESt:RESult:COUNT:FAILures?](#) on page 877

Acquisition hits

Number of acquisitions that contained at least one sample hit.

Remote command:

[MTESt:RESult:COUNT:FWAVeforms?](#) on page 877

Fail rate

Ratio of acquisition hits to the number of tested acquisitions.

Remote command:

[MTESt:RESult:FRATe?](#) on page 877

Test result

A test has failed if the number of sample hits or acquisition hits exceeds the limit of "Violation tolerance" hits.

Remote command:

`MTESt:RESult[:RESult]?` on page 876

9.2 Working with Masks

This chapter explains step-by-step how mask tests are setup and preformed. For the explanation of the individual settings, see [chapter 9.3, "Reference for Masks"](#), on page 325.

• Setting Up User Masks	318
• Setting Up a Mask Test	322
• Configuring the Mask and Hit Display	322
• Running a Mask Test	324
• Saving and Loading Masks	324
• Mask Testing on History Acquisitions	325

9.2.1 Setting Up User Masks

9.2.1.1 Creating New User Masks

There are two ways to create a new mask:

- Graphical way by tapping the mask points on the touch screen,
- Numerical entry of the x- and y-values of the mask points.

You can combine both methods. For example, at first you enter the mask quickly on the touch screen, and then modify the point coordinates with precise values.

To create a mask graphically on the touch screen

1. Tap the "Masks" icon on the toolbar.



2. Tap the corner points of the mask segment on the touch screen.
3. To finish the segment and mask definition, double-tap the last point, or tap the "Select" icon on the toolbar.



Note: Tapping any icon on the toolbar finishes the mask definition.

4. Tap outside the mask to deselect the mask segment.

You can also enter only two points to create a line. When you finish the mask segment by double-tapping the second point, the display region above or below the line is defined as mask. If the line is in the upper half of the display, the region above the line becomes the mask (upper region). If the line is in the lower half, the region below the line is taken (lower region).

To create a mask numerically in the dialog box

The settings mentioned here are described in detail in [chapter 9.3.2.1, "Mask Definition: User Mask"](#), on page 328.

1. Press the MASKS key on the front panel.
2. Select the "Mask Definition" tab.
3. Create a new mask test:
 - a) Tap the "+"-icon in the lower left corner.
 - b) Enter a name for the new mask test.A new, empty tab for the mask test appears.
4. Check the horizontal and vertical units and adjust them, if necessary.
5. In the "Mask segments" area, tap "Insert" to create a new mask segment.
6. Set the corner points of the mask segment:
 - a) In the "Definition of segment" area, tap "Insert".
Point 1 appears.
 - b) Tap the X-cell and enter the X-value of the point.
 - c) Tap the Y-cell and enter the Y-value of the point.
 - d) To insert the next point:
 - Tap "Insert" to add a point before the selected point.
 - Tap "Append" to add a point at the end of the list.
 - e) Set the X- and Y-values for this point.
 - f) Repeat the last two steps until all points are defined.

9.2.1.2 Modifying User Masks

To change an existing mask definition, you can also use the graphical method on the touch screen, or the numerical way, or combine both.

With the graphical method, you can:

- Move, add, and delete segments
- Move and delete points

Adding points to an existing segment graphically is not possible.

With the numerical method, in the "Mask Definition" tab, you have all modification possibilities. You can delete and add points and segments, change the coordinates, and also stretch a segment, or move it by adding an offset.

To add a mask segment on the touch screen

1. Tap a mask segment of the mask test that you want to complement.
2. Tap the "Masks" icon on the toolbar.



3. Tap the corner points of the new mask segment on the touch screen.
4. To finish the segment and mask definition, double-tap the last point, or tap the "Select" icon on the toolbar.

**To delete a mask segment on the touch screen**

1. On the toolbar, tap the "Delete" icon.



2. Tap the mask segment to be deleted.

To delete a point on the touch screen

1. Tap the mask segment from which you want to delete a point.
The selected segment is now in definition mode, shown with blue color.
2. On the toolbar, tap the "Delete" icon.



3. Tap the point to be deleted.

To move a segment on the touch screen

1. Drag&drop the segment to the new position.
2. Tap outside the mask to deselect the mask segment.

To move a point on the touch screen

1. Tap the mask segment to be changed.
2. Drag&drop the point to the new position.
3. Tap outside the mask to deselect the mask segment.

To change the mask definition numerically

The settings mentioned here are described in detail in [chapter 9.3.2.1, "Mask Definition: User Mask"](#), on page 328.

1. Press the MASKS key on the front panel.
2. Select the "Mask Definition" tab.
3. On the left, select the mask test for which you want to change the mask definition.
4. To add or delete a mask segment, tap the segment's row in the "Mask segments" table and tap the required button below:
 - "Insert": to add a new segment before the selected segment.
 - "Append": to add a new segment at the end of the list.
 - "Remove": to delete the selected mask segment from the list.

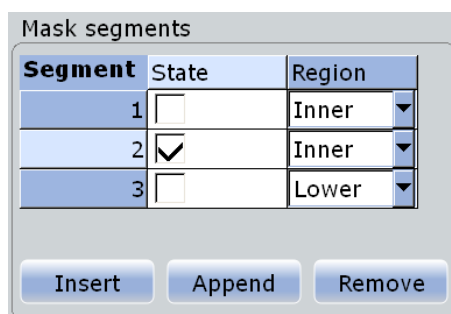

5. To add, delete, or move a point of a segment:
 - a) Select the segment in the "Mask segments" table.
 - b) Select the point in the "Definition of segment" table.
 - c) To add or delete the selected point, use the buttons below the table.
 - "Insert": to add a new point before the selected point.
 - "Append": to add a new point at the end of the list.
 - "Remove": to delete the selected point from the list.
 - d) To move the selected point, change the X- and Y-values.

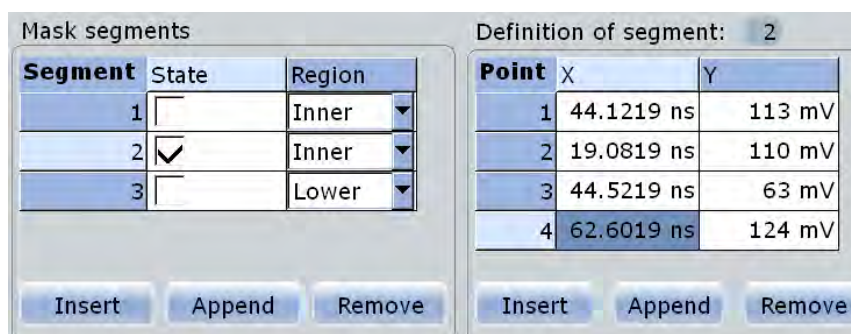

To rescale and move a mask segment

The settings mentioned here are described in detail in [chapter 9.3.2.1, "Mask Definition: User Mask"](#), on page 328.

1. Press the MASKS key on the front panel.

2. Select the "Mask Definition" tab.
3. On the left, select the mask test for which you want to change the mask definition.
4. Select the required segment in the "Mask segments" table.
5. To stretch or compress the selected mask segment, enter the "X-Factor" for horizontal scaling and the "Y-Factor" for vertical scaling. The x-values and y-values of all points are multiplied with the corresponding factor. Factors >1 stretch the mask segment, while factors between 0 and 1 compress it. Negative values are possible and change the algebraic sign.
6. To move the selected mask segment, enter the "X-Offset" for horizontal direction and the "Y-Offset" for vertical direction. The specified offset is added to the corresponding values of all points.
7. Tap "Recalculate" to perform the scaling and/or move.

9.2.2 Setting Up a Mask Test

In addition to the mask definition, the mask test contains further settings:

- the waveform to be tested
- the criteria for a failed test
- the actions to be taken if a test has failed or has been completed successfully

1. Press the MASKS key on the front panel.
2. Select the "Test Definition" tab.
3. Select the "Source" to be tested.
4. Set the conditions for a failed test:
 - a) Fail condition: select if sample hits or the number of acquisitions with sample hits are considered.
 - b) Violation tolerance: number of tolerable sample hits or acquisition hits.

A test has failed if the number of sample hits or acquisition hits exceeds the limit of violation tolerance hits.

5. Select the "Event Actions / Reset" tab.
6. For each action, select when the action will be executed:
 - "On violation" if the mask test has failed
 - "On successful completion"

9.2.3 Configuring the Mask and Hit Display

The display of masks and mask violation is the same for all mask tests.

The settings mentioned here are described in detail in [chapter 9.3.4, "Mask Display"](#), on page 336.

1. Press the MASKS key on the front panel.
2. Select the "Mask Display" tab.
3. Select "Show mask" to display the masks of all enabled mask tests on the screen.
4. Define how the sample hits are displayed:
 - a) Select "Highlight hits" to display the sample hits.
 - b) Set the "Highlight time" or "Infinite highlight".
Set the "Color" of the sample hits.
5. Define the color of the masks segments depending on the violation state:
 - Mask without violation
 - Mask with violation
 - Mask with contact: This color shows that the edge of the mask segment was touched. In this case, the resolution is not sufficient to detect if the mask was really hit or not. Zoom into the concerned area to see the correct result.

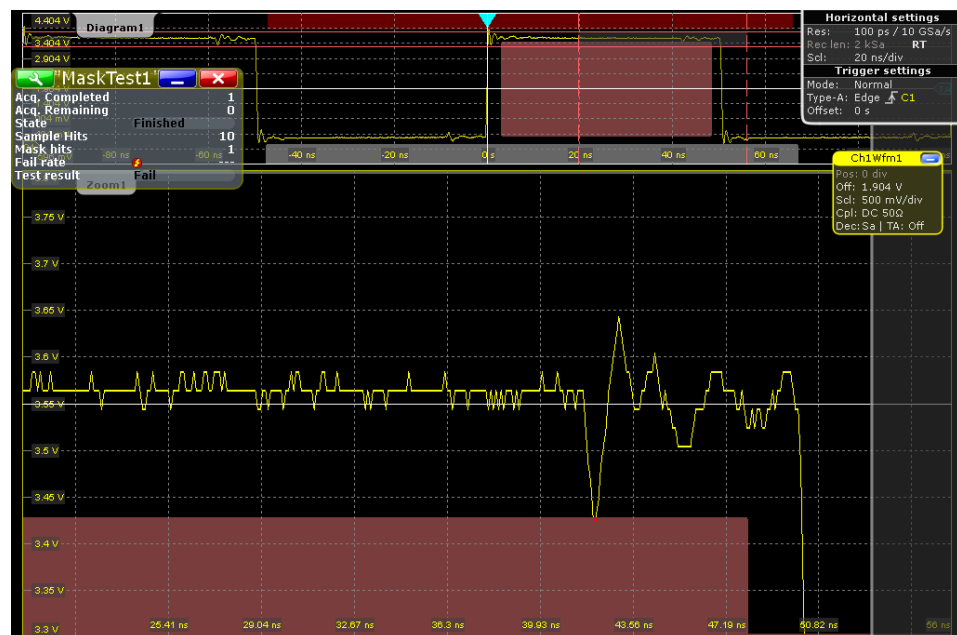

9.2.4 Running a Mask Test

Before you can start a mask test, make sure that the mask setup is complete:

- The mask is defined, see [chapter 9.2.1.1, "Creating New User Masks"](#), on page 318 and [chapter 9.2.1.2, "Modifying User Masks"](#), on page 319.
- The mask test is defined, see [chapter 9.2.2, "Setting Up a Mask Test"](#), on page 322
- The mask display is configured, see [chapter 9.2.3, "Configuring the Mask and Hit Display"](#), on page 322.

You can perform continuous testing or test a specified number of acquisitions.

1. Press the MASKS key on the front panel.
2. Select the "Test Definition" tab.
3. Select "Enable test".
If the acquisition is running, the test starts immediately.
4. If the acquisition is not running, press RUN CONT.
The tests starts and runs until you stop the acquisition or the stop action is executed if defined.
5. To test a specified number of acquisitions:
 - a) Press the ACQUISITION key.
 - b) Set the "Average count" to the number of acquisitions.
See also: "[Acquisition/average count](#)" on page 113
 - c) Press RUN N× SINGLE.

Note: If you run the acquisition with RUN CONT, the state of the mask test is set to "Finished" when this number of acquisitions has been captured but the mask testing continues until the acquisition will be stopped.

9.2.5 Saving and Loading Masks

Mask test definitions remain on the instrument until they are changed or deleted, or PRESET is performed. If you want to keep a mask test, you can save and reload them.

To save a mask

1. Press the MASKS key on the front panel.
2. Select the "Test Definition" tab.
3. To save the mask file in the current directory, change the file name if needed, and tap "Save".
You can use the automatic file name generation, see "[To define the automatic file name pattern](#)" on page 365.
4. To select the directory and enter the file name, tap "Save As".

To load a mask

1. To load the specified mask file, tap "Load."
2. To load the mask from a different file, tap "Open". Select the file from the file selection dialog box.

9.2.6 Mask Testing on History Acquisitions

In the same way as for running acquisitions, you can set up and perform the mask testing also on history waveforms.

The requirements for mask testing on history waveforms are also the same:

- The mask is defined, see [chapter 9.2.1.1, "Creating New User Masks"](#), on page 318 and [chapter 9.2.1.2, "Modifying User Masks"](#), on page 319.
 - The mask test is defined, see [chapter 9.2.2, "Setting Up a Mask Test"](#), on page 322
 - The mask display is configured, see [chapter 9.2.3, "Configuring the Mask and Hit Display"](#), on page 322.
1. Perform and finish the acquisition.
 2. Press HISTORY.
 3. In the quick-access "History" dialog box, tap "Play".

The mask testing is performed on the complete history memory, starting with the oldest acquisition. The state of the mask test is set to "Finished" when "Nx Single count" acquisitions are tested.

For details on history, see [chapter 5.4, "History"](#), on page 207.

9.3 Reference for Masks**9.3.1 Test Definition**

The "Test Definition" tab provides all settings for the mask test itself: the waveform to be tested, pass/fail conditions, and saving/loading the mask definition.



The content of the "Test Definition" tab depends on the selected definition type: "User" or "Waveform". If "Waveform" is selected, the main mask settings can be set directly on the "Test Definition" tab. For a description of these settings, see [chapter 9.3.2.2, "Mask Definition: Waveform Mask"](#), on page 331.



Make sure that the correct "Mask Test" tab is selected on the left side before you enter the settings.

SCPI commands:

[MTEST:ADD](#) on page 863

[MTEST:REMOve](#) on page 863

Enable test

Activates and deactivates the mask test. If the acquisition is running, the test starts immediately. Otherwise, the test starts when acquisition is started.

The testing is stopped when acquisition is stopped, or if a stop action is configured with [Stop acq.](#)

Closing the result box also disables the mask test.

Remote command:

[MTEST\[:STATe\]](#) on page 864

Source

Selects the waveform to be tested against the mask. All channel waveforms can be tested.

Remote command:

[MTEST:SOURce](#) on page 864

Definition type

Sets the method of mask definition.

"User"	The mask is created manually by tapping the mask points on the touch screen and/or by entering the numerical x- and y-values of the mask points.
"Waveform"	The mask is created from an existing waveform. The waveform builds the upper and lower limit line of the mask, and the limits are moved and stretched. The result is a tolerance tube around the waveform that is used as mask.
"Eye"	Requires jitter option R&S RTO-K12. The mask is created by selecting the shape and setting its dimensions according to the test standard. See: chapter 17.3, "Mask Testing on Eye Diagrams" , on page 557.

Remote command:

[MTEST:CTYPe](#) on page 865

Fail condition, Violation tolerance

The fail criteria for a mask test is set by two parameters: "Fail condition" and "Violation tolerance".

"Fail condition" defines the kind of hits to be considered for test evaluation:

- "Samples": Considers the number of samples that hit the mask.
- "Acquisitions": Considers the number of acquisitions that contain at least one sample hit. How many samples hit the mask in that acquisition is not relevant.

"Violation tolerance" sets the number of tolerable sample hits or acquisition hits.

A test has failed if the number of sample hits or acquisition hits exceeds the limit of violation tolerance hits.

Example:

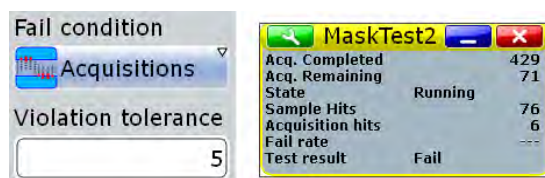

The example test has failed when the sixth acquisition violated the mask.

Remote command:

[MTEST:CONDition](#) on page 864

[MTEST:TOLerance](#) on page 865

Save / load mask test

Provides all functions to store and recall a mask test. The mask definition, defined actions and fail conditions are stored in an R&S RTO-specific xml file.

"Load, Save"	Recalls or stores the specified file.
"Open, Save As"	Opens a dialog box where you can select the directory the file name. See also: chapter 11.2.4, "File Selection Dialog" , on page 386.

"Delete" Opens a dialog box where you can select the file to be deleted.

Remote command:

`MTEST:FILE:NAME` on page 866

`MTEST:FILE:SAVE` on page 866

`MTEST:FILE:OPEN` on page 866

`MTEST:FILE:DELeTe` on page 867

9.3.2 Mask Definition

With mask definition, you define the shape of the mask - the form and position of its limit lines. The content of the "Mask Definition" tab depends on the selected "Definition type": "User" or "Waveform".

The "Definition type" is a common setting on the top of the tab, see "Definition type" on page 326.

Below, you find the specific settings:

9.3.2.1 Mask Definition: User Mask

A user mask is defined by entering the time and voltage values for all corner points of the mask segments. A user mask has at least one segment. Complex masks can have up to 16 segments.

An inner segment is an area defined by three or more points. Upper and lower segments limit the signal on top and bottom of the screen. They are defined by a line, the region above or below the line is set automatically as mask segment.

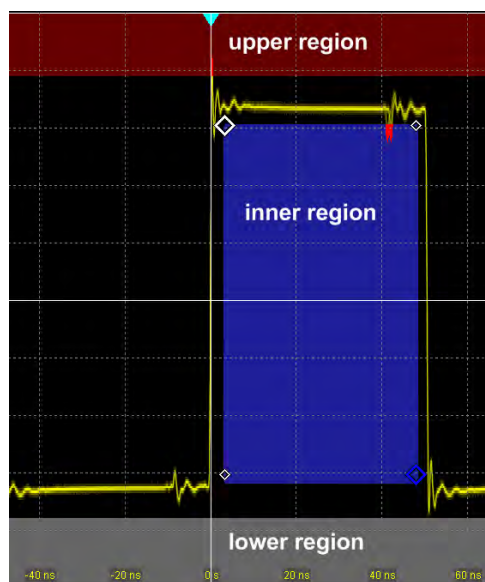

Alternatively, you can set the corner points on the touch screen and adjust the values in the "Mask Definition" tab.

To save the mask, select the "Test Definition" tab and save the mask test.

Settings overview:

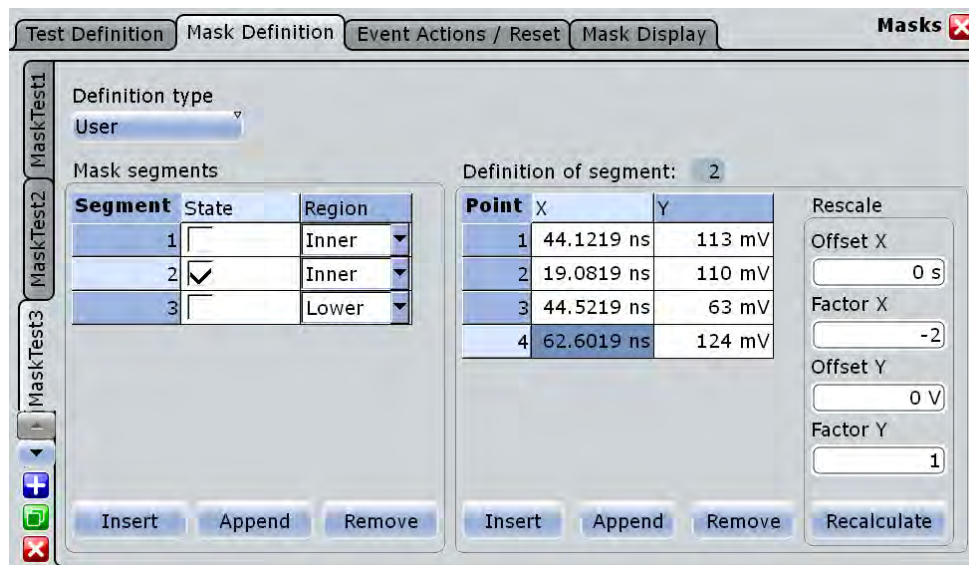

Make sure that the correct "Mask Test" tab is selected on the left side before you enter the settings.

Mask segments

Defines the number and state of mask segments for the selected mask test. Here you can:

- Insert a new segment before the selected segment.
- Append a new segment at the end of the list.
- Remove the selected mask segment from the list.
- Select the region that builds the mask.
 - Inner region: the segment points form a closed geometrical shape, which is the mask segment.
 - Upper region: the segment points are connected to a line, the display area above this line is the mask segment.
 - Lower region: the segment points are connected to a line, the display area below this line is the mask segment.
- Enable and disable the mask segments individually. Disabled segments are not considered by running tests.

Remote command:

[MTESt:SEGMENT:STATE](#) on page 867

[MTESt:SEGMENT:ADD](#) on page 868

[MTESt:SEGMENT:REMOVE](#) on page 868

[MTESt:SEGMENT:INSERT](#) on page 868

[MTESt:SEGMENT:REGION](#) on page 868

[MTESt:SEGMENT:COUNT?](#) on page 868

Definition of segment

The number of the selected segment is shown above the table. In the definition table, the individual points of the selected mask segment are listed with exact horizontal and vertical numerical coordinates. Here you can:

- Insert a new point before the selected point.
- Append a new point at the end of the list.
- Remove the selected point from the list.
- Change the x- and y-values of each point. To scale or move the complete segment, use offset and factor values, see [Rescale](#).

Remote command:

[MTESt:SEGMENT:POINT:ADD](#) on page 869

[MTESt:SEGMENT:POINT:REMOVe](#) on page 869

[MTESt:SEGMENT:POINT:INSert](#) on page 869

[MTESt:SEGMENT:POINT:X](#) on page 870

[MTESt:SEGMENT:POINT:Y](#) on page 870

[MTESt:SEGMENT:POINT:COUNT?](#) on page 870

Rescale

You can rescale and move mask segments by numerical input of factors and offsets. The values change the selected mask segment and take effect on "Recalculate".

Offset X ← Rescale

Moves the mask segment horizontally. The specified offset is added to the x-values of all points of the selected mask segment.

To take effect, tap "Recalculate".

Remote command:

[MTESt:SEGMENT:RESCale:XOFFset](#) on page 871

Factor X ← Rescale

Stretches or compresses the selected mask segment in horizontal direction. The x-values of all points of the selected mask segment are multiplied with this factor. Factors >1 stretch the mask segment, while factors between 0 and 1 compress it. Negative values are possible and change the algebraic sign.

To take effect, tap "Recalculate".

Remote command:

[MTESt:SEGMENT:RESCale:XFACTOR](#) on page 871

Offset Y ← Rescale

Moves the mask segment vertically. The specified offset is added to the y-values of all points of the selected mask segment.

To take effect, tap "Recalculate".

Remote command:

[MTESt:SEGMENT:RESCale:YOFFset](#) on page 872

Factor Y ← Rescale

Stretches or compresses the selected mask segment in vertical direction. The y-values of all points of the selected mask segment are multiplied with this factor. Factors >1 stretch the mask segment, while factors between 0 and 1 compress it. Negative values are possible and change the algebraic sign.

To take effect, tap "Recalculate".

Remote command:

`MTESt:SEGMent:RESCale:YFACTOR` on page 871

Recalculate ← Rescale

Multiplies and adds the given x- and y-factors and offsets to the coordinates of all points of the selected mask segment.

Remote command:

`MTESt:SEGMent:RESCale:RECalculate` on page 871

9.3.2.2 Mask Definition: Waveform Mask

A waveform mask is created from an existing waveform. The waveform builds the upper and lower limit line of the mask, and the limits are moved and stretched. The result is a tolerance tube around the waveform that is used as mask.

During mask testing using a waveform mask, the record length is limited to 1 MSample.

The source for a waveform mask is a reference waveform. The reference waveform can be defined before mask definition, or loaded from a file, or it is created from the waveform to be tested.

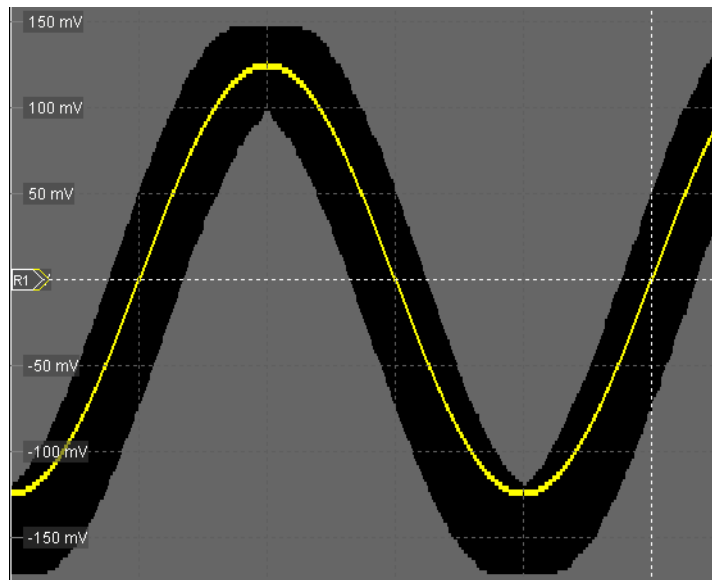

Settings overview:

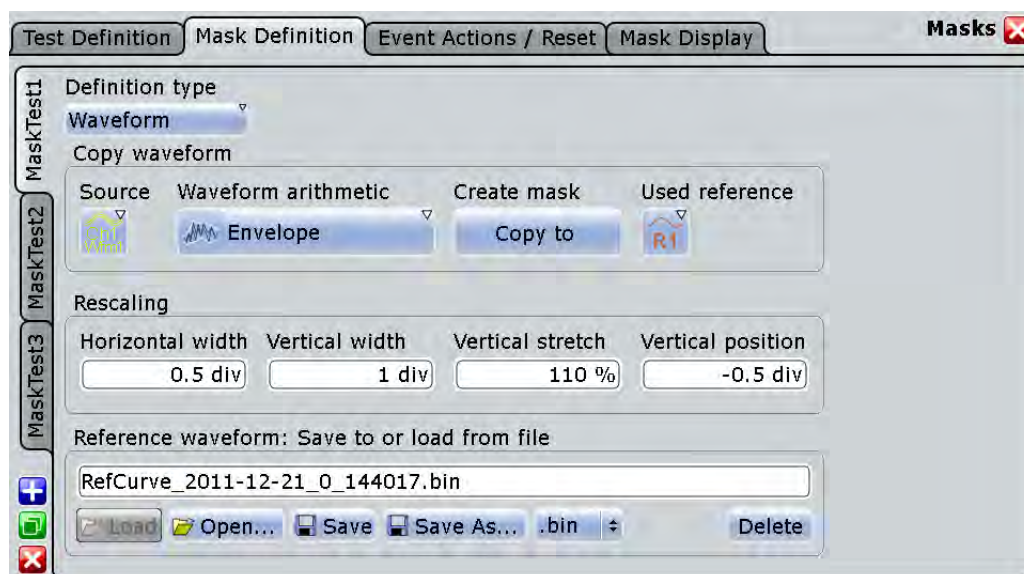

Common settings:

- "Definition type" on page 326
- "Source" on page 326
- "Wfm Arithmetic" on page 112

Create mask

Creates the upper and lower mask limit from the selected reference waveform. If the reference waveform was not defined before, it is created automatically from the mask test "Source" waveform which is selected in the "Test Definition" tab.

Remote command:

[MTEST:WFMLupdate](#) on page 873

Used reference

Sets the reference waveform from which the mask is created.

The reference waveform can be created before with "Reference Waveform Setup", or loaded from a file in the lower part of the dialog box. If the reference waveform was not defined before mask definition, it is created automatically from the mask test "Source" waveform.

Remote command:

[MTEST:REFWfm](#) on page 872

Horizontal width

Sets the width of the mask in horizontal direction. The specified number of divisions is added to the positive x-values and subtracted from the negative x-values of the mask limits in relation to the source waveform of the mask. The overall mask width is twice the specified horizontal width.

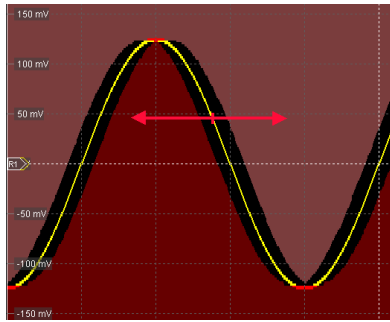

Fig. 9-1: Waveform mask with horizontal width = 0.2 div

Remote command:

`MTESt:WFMRescale:XWIDth` on page 873

Vertical width

Sets the width of the waveform mask in vertical direction. The specified number of divisions is added to the y-values of the upper mask limit and subtracted from the y-values of the lower mask limit. Thus, the upper half of the mask is pulled upwards, the lower half is pulled down, and the overall height of the mask is twice the vertical width.

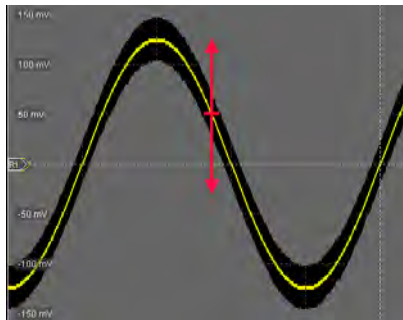

Fig. 9-2: Waveform mask with vertical width = 0.5 div

Remote command:

`MTESt:WFMRescale:YWIDth` on page 873

Vertical stretch

Sets the vertical scaling to stretch the mask in y-direction. The scaling axis is the horizontal line through the lowest value of the lower mask limit. Values > 100% stretch the mask, and values < 100% compress it.

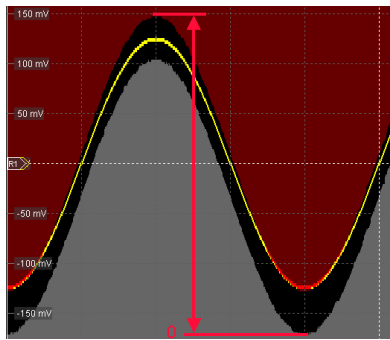

Fig. 9-3: Waveform mask with vertical width = 0.5 div, vertical position = -0.5 div, vertical stretch = 110%

Remote command:

[MTESt:WFMRescale:YSTRetch](#) on page 874

Vertical position

Moves the mask vertically within the display.

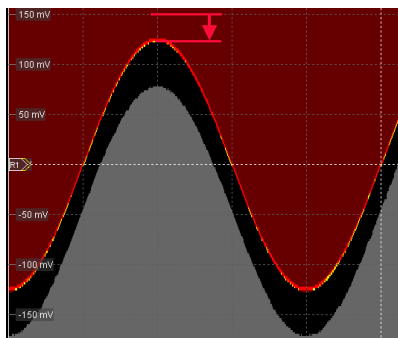

Fig. 9-4: Waveform mask with vertical width = 0.5 div and vertical position = -0.5 div

Remote command:

[MTESt:WFMRescale:YPOSITION](#) on page 874

Reference waveform: save to or load from file

Loads the waveform from the selected file to the "Reference" and creates the mask immediately.

See also: ["Save to or load from file"](#) on page 217.

9.3.3 Event Actions /Reset

The settings in this tab define what happens when the mask test has failed or when it has passed successfully. Furthermore, you can reset all totals and results in the "Mask Test" result boxes.

Most actions can be initiated either on failure or on success:

- On violation
The action is initiated as soon as the fail criteria is fulfilled.
- On successful completion

The action is initiated when the RUN N× SINGLE acquisition has finished and the fail criteria is not fulfilled - the fail condition and violation tolerance limit have not been reached.

There are two usual test practices:

- Testing a defined number of waveforms against the mask and initiate an action when the acquisition cycle has been completed without failure:
 - Set the number of acquisitions to be tested: "Average count (N-single count)"
 - Start RUN N× SINGLE
- Testing a continuous acquisition or a defined number of waveforms against the mask and initiate an action as soon as the fail criteria is fulfilled

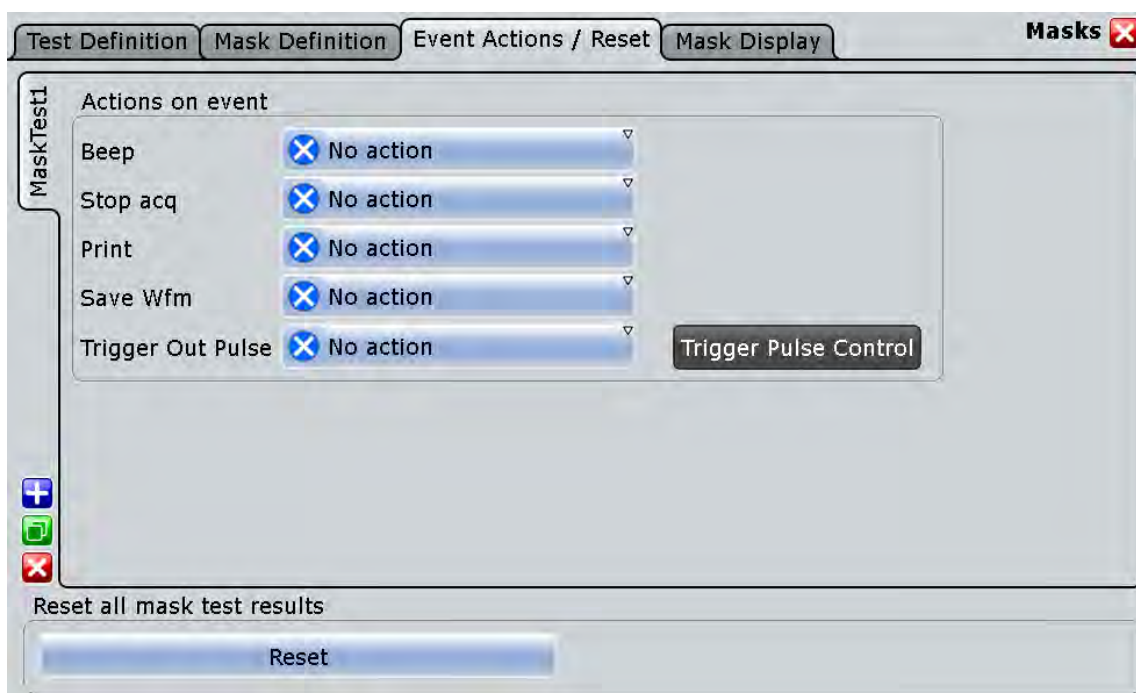

Make sure that the correct "Mask Test" tab is selected on the left side before you enter the settings.

Beep

Generates a beep sound.

Remote command:

[MTESt:ONViolation:BEEP](#) on page 874

Stop acq.

Stops the waveform acquisition on mask violation.

Remote command:

[MTESt:ONViolation:STOP](#) on page 875

Print

Prints a screenshot including the mask test results to the printer defined in the "Print" dialog box (see [chapter 11.1.1, "Configuring Printer Output and Printing"](#), on page 360).

Remote command:

[MTESt:ONViolation:PRINT](#) on page 875

Save Wfm

Saves the failed waveform as a reference waveform to the file specified in FILE > "Save/Recall" > "Waveform".

Remote command:

[MTESt:ONViolation:SAVewaveform](#) on page 875

Trigger Out Pulse

Creates a pulse on the EXT TRIGGER OUT connector on mask violation or successful completion of the test cycle. If the measurement scenario is complex, the interval between two pulses is at least 30 ms.

If this event is enabled and the mask test is running, the trigger control option "Enable trigger out" is disabled. Thus, the trigger out pulse is provided only on mask test result but not when a trigger occurs. The pulse is provided always with the minimum delay of 800 ns, the "Delay" cannot be set.

In some test scenarios, the instrument detects mask violation at display update. Therefore the minimum time difference between two pulses is 30 ms.

Reset

Clears all totals and results in all "Mask Test" result boxes.

Remote command:

[MTESt:RST](#) on page 864

9.3.4 Mask Display

The "Mask Display" tab contains all settings for mask and hit display.

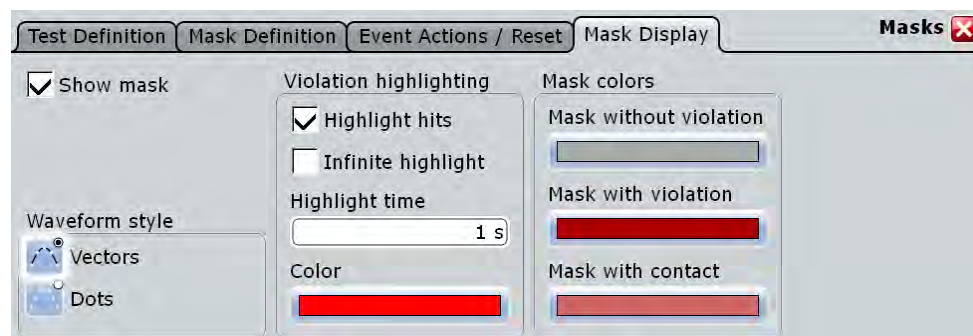
**Show mask**

Switches the display of all mask segments on or off.

Waveform style

See: "[Style](#)" on page 184.

Highlight hits

If selected, the mask hits are highlighted on the screen. You can define the color and the time of the hit display.

Infinite highlight

If selected, the mask hits are highlighted for an unlimited period of time.

Highlight time

Sets the time how long the mask hits are highlighted.

Color

Sets the color of samples that violated the mask.

Mask without violation

Sets the color of masks segments that were not hit.

Mask with violation

Sets the color of mask segments the signal has entered into.

Mask with contact

Sets the color of masks segments that were touched at the border. In this case, the resolution is not sufficient to detect if the mask was really hit or not. Zoom into the concerned area to see the actual result.

10 Search Functions

Search functions allow you to detect and analyze specific events in the acquired data quickly and simply. You can search in various waveforms for several events at once. The search area can be limited by a gate.

The search parameters for search on analog and digital channels are defined in the same way as the trigger conditions. The results are displayed in a result box and optionally shown in a zoom window.

10.1 Overview: Search Definition and Results

10.1.1 Search Definition

You can define up to 8 different searches and let them run simultaneously. For each search, you define the criteria, the parameters of each criterion, the gate, and the result display.

The instrument keeps the settings until the next preset. If you save a user-defined preset, the search settings are included in the preset.

Each search is configured in a separate tab and contains:

- **Search control**
If you enable a search and run an acquisition, the search is performed continuously on the acquired data until acquisition is stopped.
If acquisition is stopped and you enable a search, the data of the last acquisition is searched.
Enabling the search zoom window disables the search, stops a running acquisition, and displays the search results of the last acquisition in the zoom window.
- **Source**
Waveform that is searched for one or more events. You can search in analog and digital signals, math or reference waveforms, and tracks.
- **Search criteria and parameters**
Various search criteria are available, depending on the source waveform. For usual time-based waveforms, trigger searches are available. Most parameters known from trigger event definition can also be configured as search conditions. Unlike triggering, you can configure several event types to be searched for simultaneously.
If the source is an FFT spectrum, you can perform a frequency marker search by using the cursor measurement and defining the peak excursion. See [chapter 7.1.3.3, "Peak Search Tab"](#), on page 228.
- **Search gate**
Searches can be performed on the entire waveform, or only on a defined area (gate). The gate can be coupled to an existing zoom. Gating is not available for searches on digital signals.

- *Result presentation*
For each search, you define how the search results are displayed: in a result table and/or in a search zoom window.
- *Noise rejection*
Hysteresis for the selected source is defined for each search separately, in absolute or relative values.

SCPI commands:

- [SEARCH:ADD](#) on page 878
- [SEARCH:REMove](#) on page 879

10.1.2 Search Results

The results are displayed in a table and optionally in a zoom window.

Search Results box

The results of each search are tabulated in a "Search Results" box. If you search for several event types in parallel, the results are presented in several tabs - one for each search event and one for the combined results. Each tab contains a table with the position and, if available, further parameters for each result. The tables can be sorted by x-position or value, and you can define a maximum number of table entries in the "Result Presentation" dialog box. As with all result boxes, you can minimize it, display it like a diagram, and define the default position.

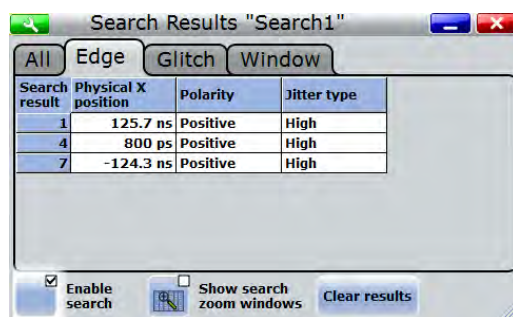

Search zoom windows

Search zoom windows allow you to analyze the search results in more detail. By default, the zoom is displayed for the selected search result. The zoom area is indicated in the diagram that displays the source waveform of the search.

Enabling the search zoom window disables the search, stops a running acquisition, and displays the search results of the last acquisition in the zoom window.

- ▶ Tap a result line in the result table to set the zoom to this event.

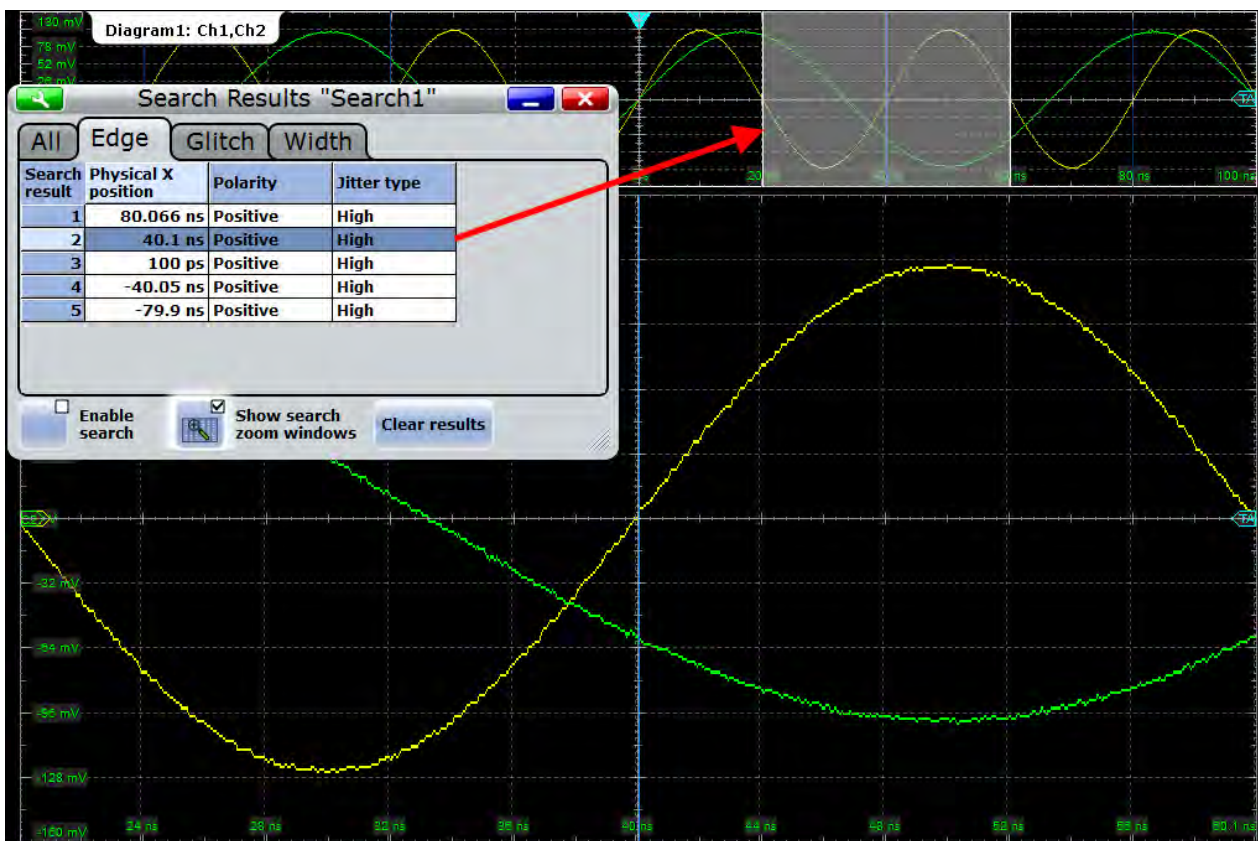

SCPI commands for result query:

- [SEARCH:RESult\[:ALL\]?](#) on page 912

10.2 Search Setup

The search setup includes the source selection, the selection of search events (criteria), event-specific search conditions, and search control.

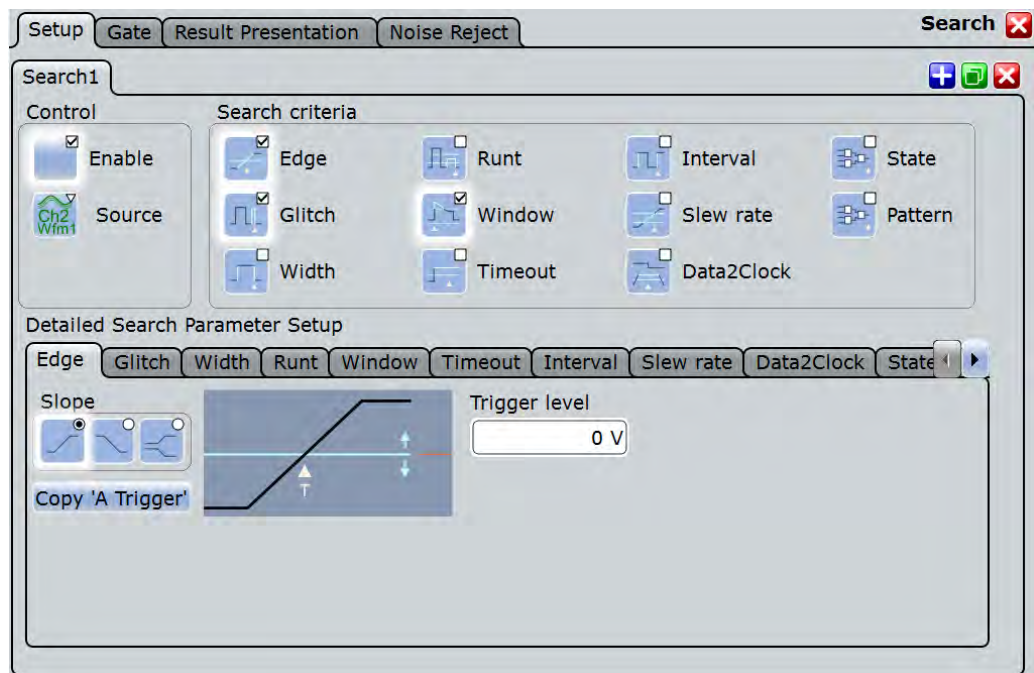

10.2.1 Search Criteria

Access: SEARCH > "Setup" tab

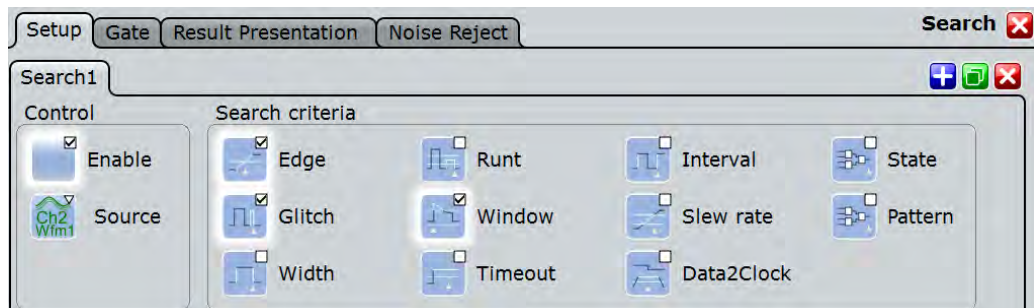

Enable

If you enable a search and run an acquisition, the search is performed continuously on the acquired data until acquisition is stopped.

If acquisition is stopped and you enable a search, the data of the last acquisition is searched.

Remote command:

[SEARCH:ONLine](#) on page 879

[SEARCH:ALL](#) on page 879

Source

Defines the waveform to be searched. The source can be any analog and digital input signal, math or reference waveform or track.

Depending on the selected source, different search criteria are available. For digital channel sources, only edge, width, timeout and Data2Clock trigger searches can be used.

Remote command:

[SEARCH:SOURCE](#) on page 879

Edge, Glitch, Width, Runt, Window, Timeout, Interval, Slew rate, Data2Clock, State, Pattern

Includes or excludes the search criteria in the next search. You can enable several event types for simultaneous search.

Remote command:

[SEARCH:TRIGger:EDGE\[:STATE\]](#) on page 880

[SEARCH:TRIGger:GLITCh\[:STATE\]](#) on page 880

[SEARCH:TRIGger:WIDTh\[:STATE\]](#) on page 881

[SEARCH:TRIGger:RUNT\[:STATE\]](#) on page 880

[SEARCH:TRIGger:WINDow\[:STATE\]](#) on page 881

[SEARCH:TRIGger:TIMEout\[:STATE\]](#) on page 880

[SEARCH:TRIGger:INTerval\[:STATE\]](#) on page 880

[SEARCH:TRIGger:SLEWrate\[:STATE\]](#) on page 880

[SEARCH:TRIGger:DATatoclock\[:STATE\]](#) on page 880

[SEARCH:TRIGger:STATE\[:STATE\]](#) on page 880

[SEARCH:TRIGger:PATTern\[:STATE\]](#) on page 880

10.2.2 Search Parameters

For trigger-like searches, most parameters available for trigger event definition can also be configured as search conditions. However, not only signal channels, but also math and reference waveforms can be selected as the search source. Each event type is defined in a separate subtab.

• Edge	342
• Glitch	343
• Width	344
• Runt	345
• Window	346
• Timeout	347
• Interval	347
• Slew Rate	348
• Data2Clock	349
• State	350
• Pattern	350

10.2.2.1 Edge

The edge search works the same way as the edge trigger.

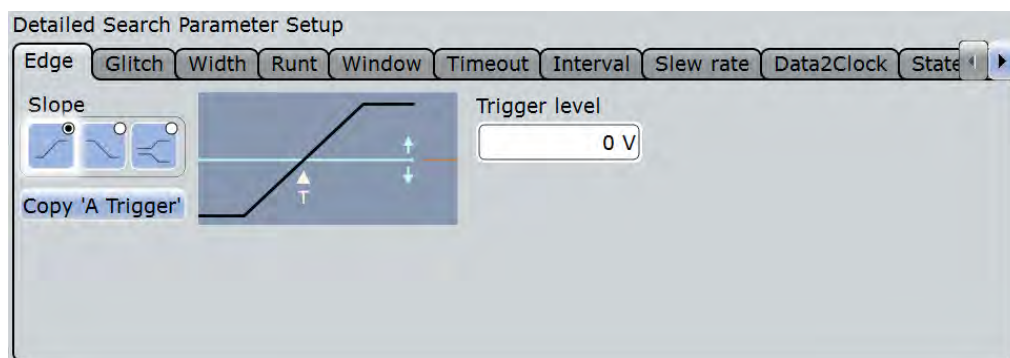

Slope

Sets the edge type: rising edge ("Positive"), falling edge ("Negative"), or both.

Remote command:

[SEARCh:TRIGger:EDGE:SLOPe](#) on page 882

Trigger level

Sets the voltage level for trigger search. The value is used for all search event types that require one trigger level. The search trigger level is search-specific, you can define different levels in different searches for the same event.

Remote command:

[SEARCh:TRIGger:LEVel\[:VALue\]](#) on page 881

Copy 'A Trigger'

Copies the trigger type-specific settings from the A-trigger configuration to the search settings. The source itself is not copied.

Remote command:

[SEARCh:TRIGger:EDGE:ACOPY](#) on page 881
[SEARCh:TRIGger:GLITCh:ACOPY](#) on page 881
[SEARCh:TRIGger:WINDow:ACOPY](#) on page 881
[SEARCh:TRIGger:WIDTh:ACOPY](#) on page 881
[SEARCh:TRIGger:RUNT:ACOPY](#) on page 881
[SEARCh:TRIGger:WINDow:ACOPY](#) on page 881
[SEARCh:TRIGger:TIMEout:ACOPY](#) on page 881
[SEARCh:TRIGger:INTerval:ACOPY](#) on page 881
[SEARCh:TRIGger:SLEWrate:ACOPY](#) on page 881
[SEARCh:TRIGger:DATatoclock:ACOPY](#) on page 881
[SEARCh:TRIGger:STATe:ACOPY](#) on page 881
[SEARCh:TRIGger:PATTern:ACOPY](#) on page 881

10.2.2.2 Glitch

The glitch search works the same way as the glitch trigger. To apply the trigger settings to search, tap [Copy 'A Trigger'](#).

The glitch search is not available if the search source is a digital channel.

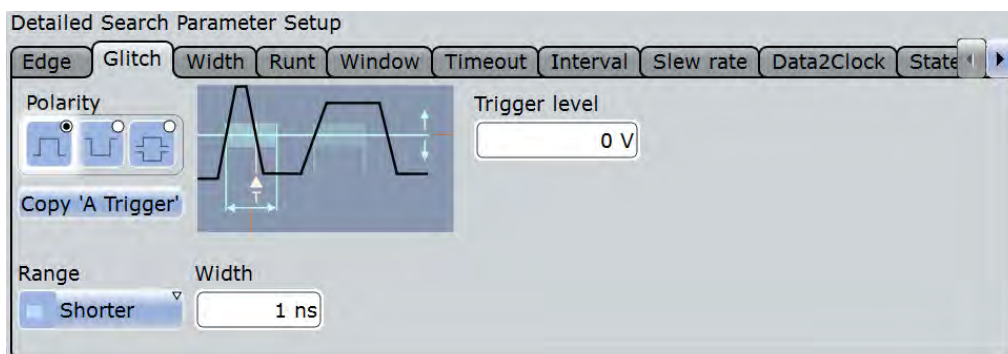

Polarity, Range, Width

See trigger settings:

- "Range" on page 145
- "Width" on page 145
- "Polarity" on page 145

Remote command:

[SEARCH:TRIGGER:GLITCH:POLARITY](#) on page 882

[SEARCH:TRIGGER:GLITCH:RANGE](#) on page 883

[SEARCH:TRIGGER:GLITCH:WIDTH](#) on page 883

Trigger level

Sets the voltage level for trigger search. The value is used for all search event types that require one trigger level. The search trigger level is search-specific, you can define different levels in different searches for the same event.

Remote command:

[SEARCH:TRIGGER:LEVEL\[:VALUE\]](#) on page 881

10.2.2.3 Width

The width search works the same way as the width trigger. To apply the trigger settings to search, tap [Copy 'A Trigger'](#).

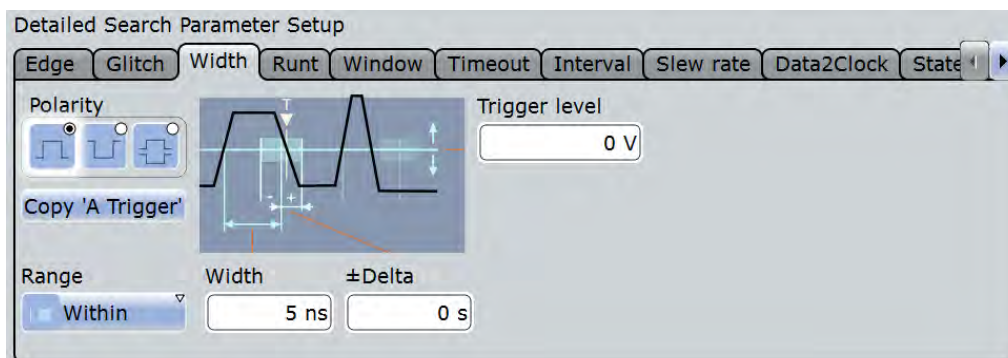

Polarity, Range, Width, ±Delta

See trigger settings:

- "Polarity" on page 146

While the width trigger can only analyze positive or negative polarity, searching for a width is also possible for both polarities at the same time ("Either").

- "Range" on page 146
- "Width" on page 147
- "±Delta" on page 147

Remote command:

[SEARCH:TRIGGER:WIDTH:POLARITY](#) on page 890

[SEARCH:TRIGGER:WIDTH:RANGE](#) on page 891

[SEARCH:TRIGGER:WIDTH:WIDTH](#) on page 891

[SEARCH:TRIGGER:WIDTH:DELTA](#) on page 890

Trigger level

Sets the voltage level for trigger search. The value is used for all search event types that require one trigger level. The search trigger level is search-specific, you can define different levels in different searches for the same event.

Remote command:

[SEARCH:TRIGGER:LEVEL\[:VALUE\]](#) on page 881

10.2.2.4 Runt

The runt search settings are the same as the runt trigger settings. To apply the trigger settings to search, tap [Copy 'A Trigger'](#).

The runt search is not available if the search source is a digital channel.

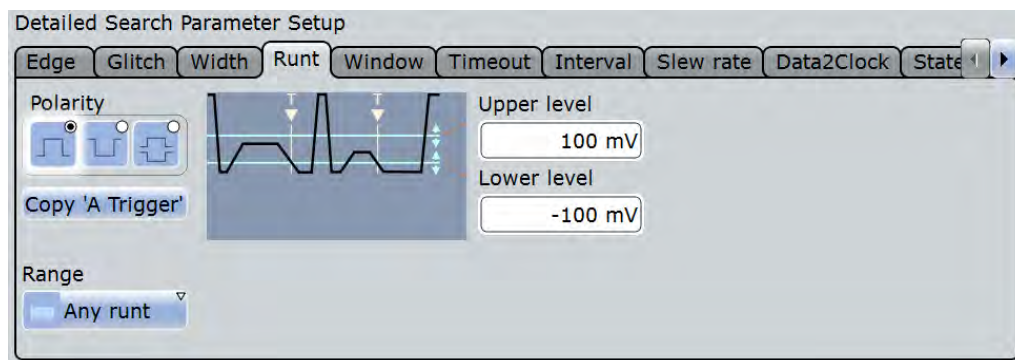

Polarity, Range, Runt width, ±Delta

Time limit for the runt, see trigger settings:

- "Polarity" on page 145
- "Range" on page 148
- "Runt width" on page 148
- "±Delta" on page 148

Remote command:

[SEARCH:TRIGGER:RUNT:POLARITY](#) on page 885

[SEARCH:TRIGGER:RUNT:RANGE](#) on page 886

[SEARCH:TRIGGER:RUNT:WIDTH](#) on page 886

[SEARCH:TRIGGER:RUNT:DELTA](#) on page 885

Upper level, Lower level

Set the upper and lower voltage thresholds. The amplitude of a runt crosses the first threshold twice in succession without crossing the second one.

Remote command:

[SEARCH:TRIGger:LEVel:RUNT:UPPer](#) on page 887

[SEARCH:TRIGger:LEVel:RUNT:LOWer](#) on page 887

10.2.2.5 Window

The window search settings are the same as the window trigger settings. This search type is not available if the search source is a digital channel. To apply the trigger settings to search, tap [Copy 'A Trigger'](#).

The window search is not available if the search source is a digital channel.

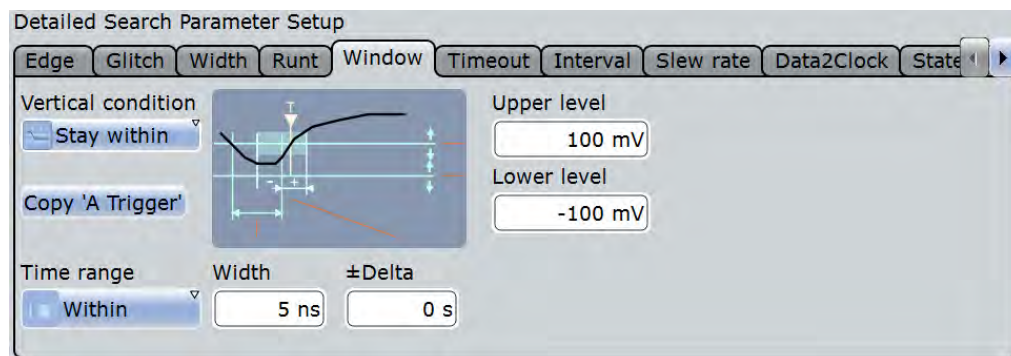
**Vertical condition**

Defines the run of the signal relative to the window, see ["Vertical condition"](#) on page 149.

Remote command:

[SEARCH:TRIGger:WINDow:RANGe](#) on page 892

Time condition, Width, ±Delta

Set the time limit for the vertical condition, see

- ["Time condition"](#) on page 149
- ["Width"](#) on page 150
- ["±Delta"](#) on page 150

Remote command:

[SEARCH:TRIGger:WINDow:TIMerange](#) on page 893

[SEARCH:TRIGger:WINDow:WIDTh](#) on page 893

[SEARCH:TRIGger:WINDow:DELTA](#) on page 892

Upper level, Lower level

Set the upper and lower voltage thresholds. The amplitude of a runt crosses the first threshold twice in succession without crossing the second one.

Remote command:

[SEARCH:TRIGger:LEVel:WINDow:UPPer](#) on page 894

[SEARCH:TRIGger:LEVel:WINDow:LOWer](#) on page 894

10.2.2.6 Timeout

The timeout search settings are the same as the timeout trigger settings. To apply the trigger settings to search, tap [Copy 'A Trigger'](#).

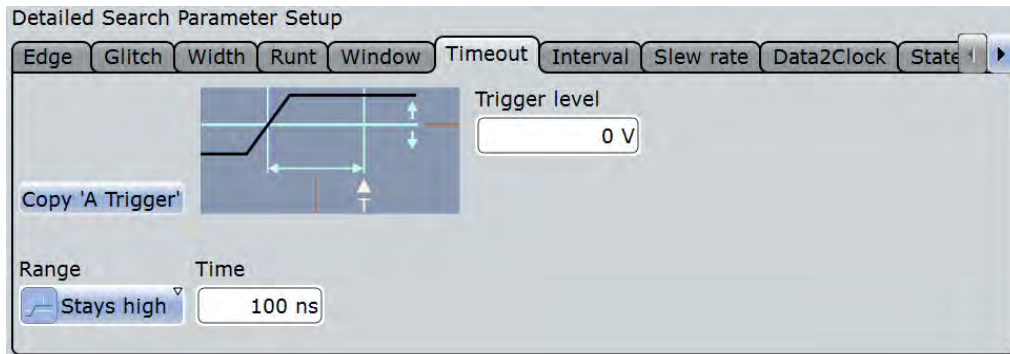

Range, Time

Set the timeout condition, see

- ["Range"](#) on page 151
- ["Time"](#) on page 151

Remote command:

[SEARCH:TRIGger:TIMEout:RANGe](#) on page 889

[SEARCH:TRIGger:TIMEout:TIME](#) on page 890

Trigger level

Sets the voltage level for trigger search. The value is used for all search event types that require one trigger level. The search trigger level is search-specific, you can define different levels in different searches for the same event.

Remote command:

[SEARCH:TRIGger:LEVel\[:VALue\]](#) on page 881

10.2.2.7 Interval

The interval search settings are the same as the interval trigger settings. To apply the trigger settings to search, tap [Copy 'A Trigger'](#).

The interval search is not available if the search source is a digital channel.

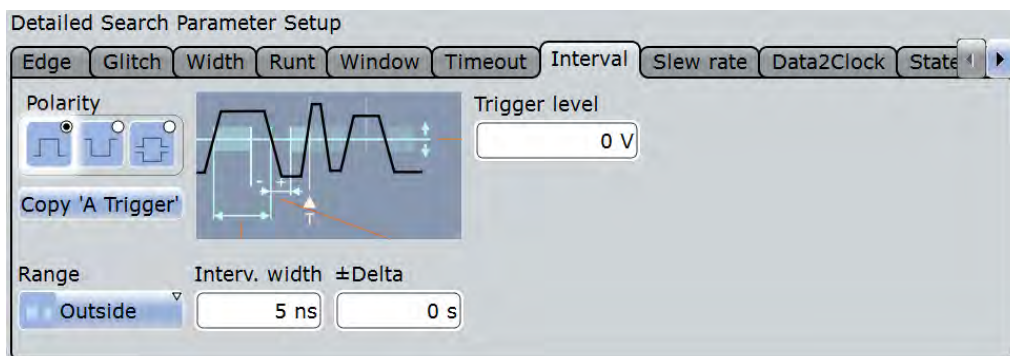

Polarity, Range, Interv. width, \pm Delta

Set the interval condition, see

- "Polarity" on page 145
While the interval trigger can only analyze only positive or negative polarity, searching for a width is also possible for both polarities at the same time ("Either").
- "Range" on page 152
- "Interv. width" on page 152
- " \pm Delta" on page 152

Remote command:

`SEARCH:TRIGger:INTerval:POLarity` on page 884

`SEARCH:TRIGger:INTerval:RANGe` on page 884

`SEARCH:TRIGger:INTerval:WIDTh` on page 884

`SEARCH:TRIGger:INTerval:DELTA` on page 883

Trigger level

Sets the voltage level for trigger search. The value is used for all search event types that require one trigger level. The search trigger level is search-specific, you can define different levels in different searches for the same event.

Remote command:

`SEARCH:TRIGger:LEVel[:VALue]` on page 881

10.2.2.8 Slew Rate

The slew rate search settings are the same as the slew rate trigger settings. To apply the trigger settings to search, tap [Copy 'A Trigger'](#).

The slew rate search is not available if the search source is a digital channel.

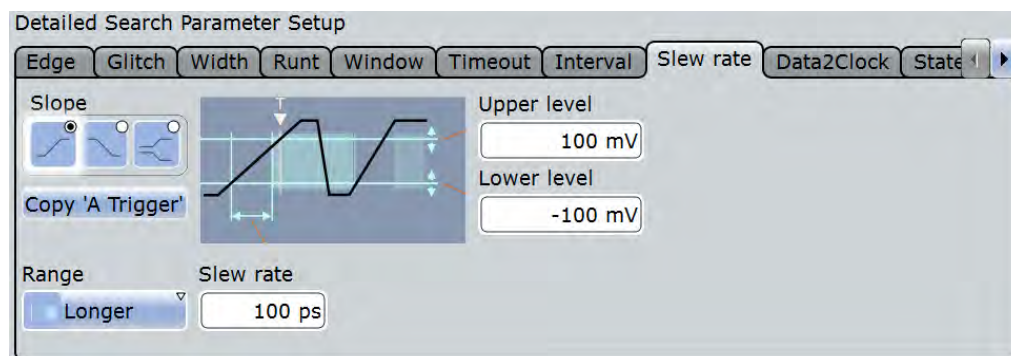
**Polarity, Range, Slew rate, \pm Delta**

- "Slope" on page 143
- "Range" on page 153
- "Slew rate" on page 153

- "[±Delta](#)" on page 154

Remote command:

[SEARCH:TRIGger:SLEWrate:SLOPe](#) on page 888

[SEARCH:TRIGger:SLEWrate:RANGe](#) on page 887

[SEARCH:TRIGger:SLEWrate:TIME](#) on page 888

[SEARCH:TRIGger:SLEWrate:DELTA](#) on page 887

Upper level, Lower level

Set the upper and lower voltage thresholds. When the signal crosses a level, the slew rate measurement starts or stops depending on the selected slope.

Remote command:

[SEARCH:TRIGger:LEVel:TRANSition:UPPer](#) on page 889

[SEARCH:TRIGger:LEVel:TRANSition:LOWer](#) on page 889

10.2.2.9 Data2Clock

The Data2Clock search settings are the same as the Data2Clock trigger settings. To apply the trigger settings to search, tap [Copy 'A Trigger'](#).

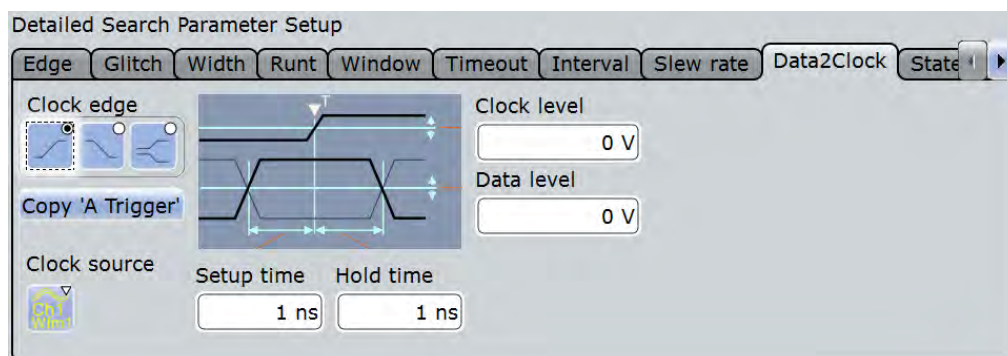

Clock source, Clock edge, Clock level

Set the clock settings. Both "Clock level" and "Clock edge" define the starting point for calculation of the setup and hold time.

Remote command:

[SEARCH:TRIGger:DATatoclock:CSOource](#) on page 895

[SEARCH:TRIGger:DATatoclock:CEdGe](#) on page 894

[SEARCH:TRIGger:DATatoclock:CLEVel](#) on page 895

Data level

Sets the voltage level for the data signal. At this level, the setup and hold time is measured.

Remote command:

[SEARCH:TRIGger:LEVel\[:VALue\]](#) on page 881

Setup time, Hold time

Sets the minimum time **before** (Setup) and **after** (Hold) the clock edge while the data signal must stay steady above or below the data level.

See also: "[Setup time](#)" on page 155 and "[Hold time](#)" on page 155.

Remote command:

[SEARCH:TRIGger:DATatoclock:STIME](#) on page 896

[SEARCH:TRIGger:DATatoclock:HTIME](#) on page 895

10.2.2.10 State

The state search is a qualified edge search. To apply the trigger settings to search, tap [Copy 'A Trigger'](#).

The state search is only available for analog channel sources (Ch1 to Ch4).

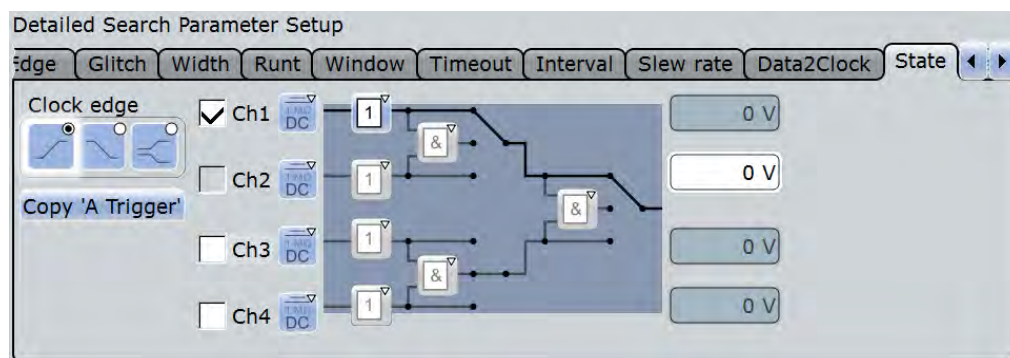

Clock source, Clock edge

Define the clock settings. The clock signal is the waveform to be searched.

Remote command:

[SEARCH:TRIGger:STATe:CSource](#) on page 901

[SEARCH:TRIGger:STATe:CEdGe](#) on page 901

[SEARCH:TRIGger:STATe:CLEVel](#) on page 901

State pattern

State settings are the same as for the state trigger. For details, see [chapter 4.3.2, "Trigger Qualification"](#), on page 163.

Remote command:

[SEARCH:TRIGger:STATe:A\[:ENABLe\]](#) on page 902

[SEARCH:TRIGger:STATe:A:LOGic](#) on page 902

[SEARCH:TRIGger:STATe:AB:LOGic](#) on page 903

[SEARCH:TRIGger:STATe:ABCD:LOGic](#) on page 903

10.2.2.11 Pattern

The pattern search combines a logical combination of the input channels with a timing condition. The settings are the same as for the pattern trigger. To apply the trigger settings to search, tap [Copy 'A Trigger'](#).

The pattern search is only available for analog channel sources (Ch1 to Ch4).

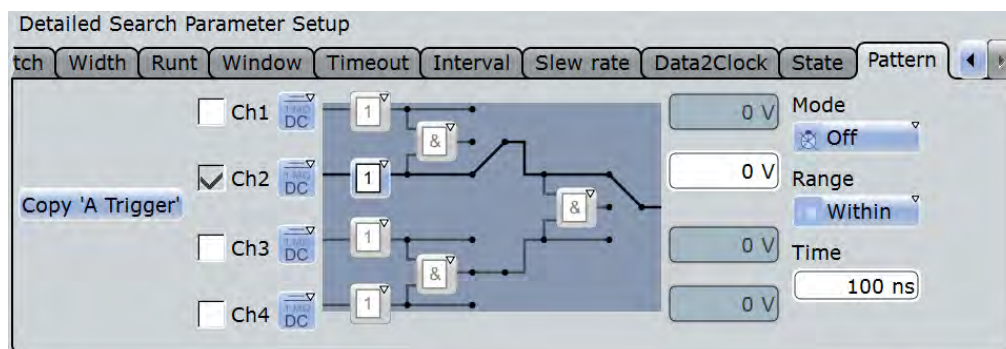

Pattern

Pattern search settings are the same as for the pattern trigger. For details, see "[Pattern](#)" on page 164.

Remote command:

[SEARCH:TRIGGER:PATTERN:A\[:ENABLE\]](#) on page 896

[SEARCH:TRIGGER:PATTERN:A:LOGIC](#) on page 897

[SEARCH:TRIGGER:PATTERN:AB:LOGIC](#) on page 898

[SEARCH:TRIGGER:PATTERN:ABCD:LOGIC](#) on page 898

Timing condition: Mode, Range, Time, Width, \pm Delta

Additional time limitation to the pattern, see "[State timing](#)" on page 157

Remote command:

[SEARCH:TRIGGER:PATTERN:MODE](#) on page 898

[SEARCH:TRIGGER:PATTERN:TIMEOUT:MODE](#) on page 899

[SEARCH:TRIGGER:PATTERN:TIMEOUT\[:TIME\]](#) on page 899

[SEARCH:TRIGGER:PATTERN:WIDTH:RANGE](#) on page 899

[SEARCH:TRIGGER:PATTERN:WIDTH\[:WIDTH\]](#) on page 900

[SEARCH:TRIGGER:PATTERN:WIDTH:DELTA](#) on page 900

10.2.3 Configuring the Search Setup

There are two ways to create a search: creating a simple default search using the toolbar icon, or setting up a more complex search using the dialog box.

To perform a simple search

1. If more than one waveform is in the diagram, select the waveform to be searched by tapping it in the diagram.
2. Select the "Search" icon on the toolbar.



3. Tap the diagram with the waveform to be searched, or drag a rectangle on the diagram to define the search area.

If the source is a time-based waveform, the default edge search is configured as "Search<x>" and performed. The "Search Results" box is displayed, and the acquisition is stopped.

To create and configure a user-defined search

1. Press the SEARCH key.
2. Tap the "Copy" icon to copy an existing search configuration, or the "Add" icon.



3. Enter a name for the search using the on-screen keyboard.
4. Select the "Setup" tab.
5. Select the "Source" waveform on which you want to perform the search.
6. To configure a trigger search, proceed as follows:
 - a) Select the events to be included in the search.
 - b) Define the settings of the first search event.
To use the same conditions as defined in the trigger configuration of the A-event, tap "Copy 'A-Trigger'". The selected trigger settings are applied to the search settings.
 - c) Repeat the previous steps to define further events for the same search.
7. To perform the search only on a part of the waveform, configure the gate in the "Gate" tab as described in [chapter 10.3.2, "Defining the Search Gate"](#), on page 354.
8. To filter out noise from the search results, configure noise rejection as described in [chapter 10.5.2, "Defining Noise Rejection for Searches"](#), on page 359.

10.3 Search Gate

The gate defines the search area within the source waveform. You can use absolute or relative values to define the gate, or couple it to a previously defined zoom area.

10.3.1 Gate Settings

The search gate settings are identical to those for gate areas for measurements or FFT analysis.

Gating is not available if the search source is a digital channel.

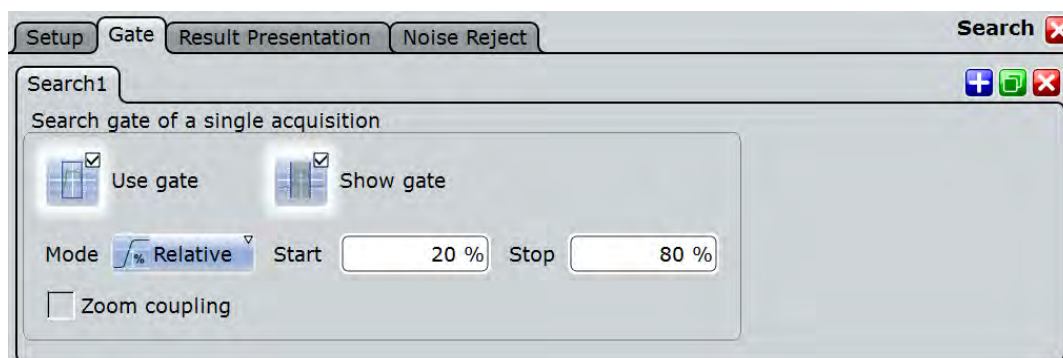
**Use Gate**

Performs the search only on the defined gate area of the source waveform.

Remote command:

[SEARCh:GATE\[:STATe\]](#) on page 903

Show gate

Displays the gate area in the source diagram.

Remote command:

[CALCulate:MATH<m>:FFT:GATE:SHOW](#) on page 858

[MEASurement<m>:GATE:SHOW](#) on page 845

[SEARCh:GATE:SHOW](#) on page 904

Mode

Defines whether the gate settings are configured using absolute or relative values.

"Absolute" The gate is defined by absolute start and stop values.

"Relative" The gate's start and stop values are defined by a percentage of the value range.

Remote command:

[CALCulate:MATH<m>:FFT:GATE:MODE](#) on page 857

[MEASurement<m>:GATE:MODE](#) on page 844

[SEARCh:GATE:MODE](#) on page 904

(Relative) Start

Defines the starting value for the gate.

Remote command:

[CALCulate:MATH<m>:FFT:GATE:ABSolute:START](#) on page 857

[CALCulate:MATH<m>:FFT:GATE:RELative:START](#) on page 858

[MEASurement<m>:GATE:ABSolute:START](#) on page 844

[MEASurement<m>:GATE:RELative:START](#) on page 844

[SEARCh:GATE:ABSolute:START](#) on page 904

[SEARCh:GATE:RELative:START](#) on page 905

(Relative) Stop

Defines the end value for the gate.

Remote command:

[CALCulate:MATH<m>:FFT:GATE:ABSolute:STOP](#) on page 857

[CALCulate:MATH<m>:FFT:GATE:RELative:STOP](#) on page 858

[MEASurement<m>:GATE:ABSolute:STOP](#) on page 844

[MEASurement<m>:GATE:RELative:STOP](#) on page 844

[SEARCh:GATE:ABSolute:STOP](#) on page 904

[SEARCh:GATE:RELative:STOP](#) on page 905

Zoom coupling

Zoom coupling is available if a zoom is defined. As long as "Zoom coupling" is enabled, the gate area is defined identically to the zoom area - if you change the zoom, the gate changes as well.

If several zoom diagrams are defined, select the zoom diagram to be used for gating. The "Start" and "Stop" values of the gate are adjusted accordingly.

Zoom coupling can be set for measurement gates, FFT gates, and search gates.

Remote command:

[CALCulate:MATH<m>:FFT:GATE:ZCOupling](#) on page 858

[MEASurement<m>:GATE:ZCOupling](#) on page 845

[SEARCh:GATE:ZCOupling](#) on page 905

[SEARCh:GATE:ZDIagram](#) on page 905

10.3.2 Defining the Search Gate

If you create a search using the "Search" toolbar icon, you can directly define the gate by dragging a rectangle on the diagram. Otherwise, you define the gate in the "Gate" tab of the "Search" dialog box.

1. Press the SEARCH key and select the "Gate" tab.
2. Select the search for which you want to define the gate.
3. Use one of the following methods:
 - Set the absolute or relative "Mode" and enter the start and stop values of the gate area.
 - If a zoom area has already been defined for the waveform, couple the gate area to the zoom area by selecting the "Zoom coupling" option. If several zoom diagrams are defined, select the zoom diagram to be used for gating.
4. Tap "Use gate" to enable the gate.
5. Optionally, tap "Show gate" to display the gate area in the diagram.

10.4 Result Presentation

Search results are displayed in a table in the "Search Results" box. The result tables can be sorted by x-position or value. You can define a maximum number of table entries.

In addition, a zoom window for a selected search result can be displayed so that you can analyze the result in more detail.

10.4.1 Result Presentation Settings

The following settings configure the layout of the result table in the "Search Results" box and the size and position of the search zoom window.

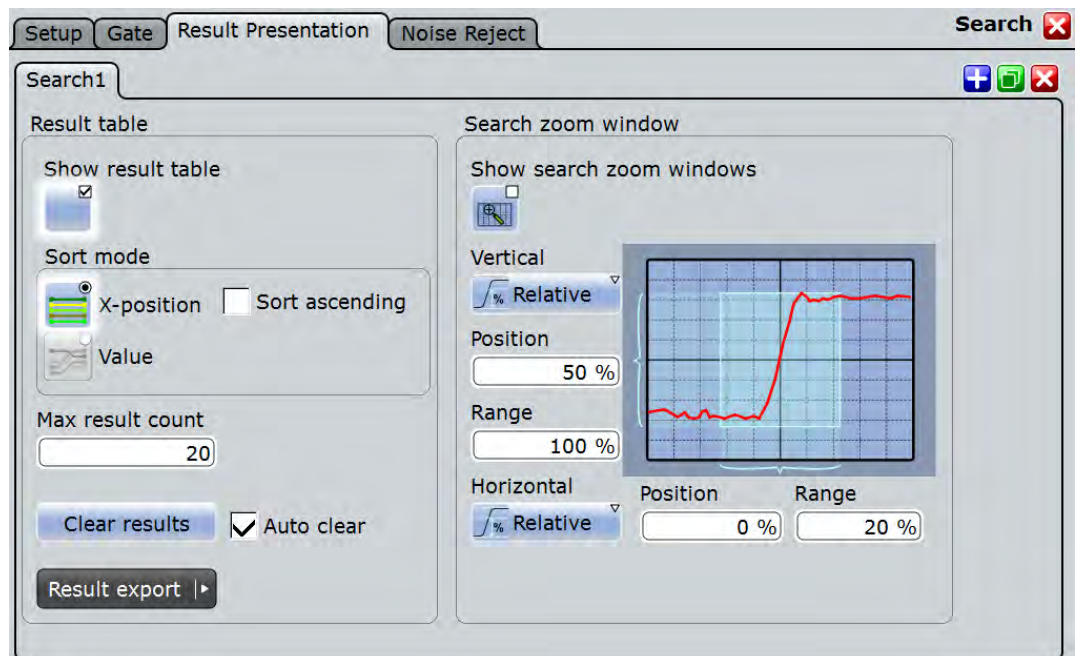

Result table

These settings refer to the search result table.

Show result table ← Result table

Displays or hides the search result table.

Remote command:

[SEARCh:RESult:SHOW](#) on page 911

Sort mode ← Result table

Sorts the search results by x-value position or value of the result.

Remote command:

[SEARCh:RESult:SORT\[:MODE\]](#) on page 912

Sort ascending ← **Result table**

By default, the results are listed in descending order, i.e. the largest value at the top. To change the sorting direction, enable "Sort ascending".

Remote command:

[SEARCh:RESult:SORT:ASCending](#) on page 911

Max result count

Defines the maximum number of entries in the search result table.

Remote command:

[SEARCh:RESult:LIMit](#) on page 911

Auto clear

Automatically clears the results before each new search.

Clear results

Clears the search results once to start a new search.

Remote command:

[SEARCh:CLEar](#) on page 878

Search zoom window

The search results can be displayed in a zoom window, which allows you to analyze the search results in more detail.

The zoom window settings are identical to those for other waveforms. Note that the settings for the search zoom window are also changed when you move the search zoom area manually, and that they remain valid for **all** search result zoom windows.

The search zoom area is marked in the waveform diagram. You can change the color of the area with: "Display" menu > "Diagram layout" > "[Search result gate symbol color](#)" on page 188.

Show search zoom windows ← **Search zoom window**

If enabled, a zoom window is displayed for the currently selected search result. The zoom area is indicated in the diagram that displays the source waveform of the search.

Remote command:

[SEARCh:RESDiagram:SHOW](#) on page 909

Vertical ← **Search zoom window**

Defines whether absolute or relative values are used to specify the y-axis values.

Remote command:

[LAYout:ZOOM:VERTical:MODE](#) on page 766

[SEARCh:RESDiagram:VERT:MODE](#) on page 910

Position / Relative position (vertical) ← Search zoom window

Defines the y-value of the centerpoint of the zoom area.

Remote command:

[LAYout:ZOOM:VERTical:ABSolute:POSition](#) on page 766

[LAYout:ZOOM:VERTical:RELative:POSition](#) on page 767

[SEARch:RESDiagram:VERT:ABSolute:POSition](#) on page 909

[SEARch:RESDiagram:VERT:RELative:POSition](#) on page 910

Range / Relative Range (vertical) ← Search zoom window

Defines the height of the zoom area.

Remote command:

[LAYout:ZOOM:VERTical:RELative:SPAN](#) on page 768

[LAYout:ZOOM:VERTical:ABSolute:SPAN](#) on page 767

[SEARch:RESDiagram:VERT:ABSolute:SPAN](#) on page 910

[SEARch:RESDiagram:VERT:RELative:SPAN](#) on page 910

Horizontal ← Search zoom window

Defines whether absolute or relative values are used to specify the x-axis values.

Remote command:

[LAYout:ZOOM:HORIZ:MODE](#) on page 763

[SEARch:RESDiagram:HORIZ:MODE](#) on page 908

Position / Relative position (horizontal) ← Search zoom window

Defines the x-value of the centerpoint of the zoom area.

Remote command:

[LAYout:ZOOM:HORIZ:ABSolute:POSition](#) on page 763

[LAYout:ZOOM:HORIZ:RELative:POSition](#) on page 765

Range / Relative Range (horizontal) ← Search zoom window

Defines the width of the zoom area.

Remote command:

[LAYout:ZOOM:HORIZ:ABSolute:SPAN](#) on page 764

[LAYout:ZOOM:HORIZ:RELative:SPAN](#) on page 765

[SEARch:RESDiagram:HORIZ:ABSolute:SPAN](#) on page 908

[SEARch:RESDiagram:HORIZ:RELative:SPAN](#) on page 909

10.4.2 Configuring the Search Results Presentation

Initially, the "Search Results" box is displayed in front of the other diagrams or as result icon on the signal bar, depending on the default setting in the "Diagram Layout" tab. Alternatively, you can display it in its own area on the screen, like any other diagram.

For details, see "Displaying Results" in the "Getting Started" manual.

To configure the result tables

1. Press the SEARCH key to open the "Search" dialog box.

2. Select the tab for the search you want to configure.
3. Select the "Result Presentation" tab.
4. Select "Show result table" to display the "Search Results" box.
5. Select the sort mode of the result table.
6. By default, the results are listed in descending order, i.e. the largest value at the top. To change the sorting direction, enable "Sort ascending".
7. Define a maximum number of results to be displayed in the result table in the "Max result count" field.

To display search zoom windows

1. In the "Search Results" box, select "Show search zoom windows".
This disables a running search and a running acquisition.
2. If you need to adjust the search zoom area, you can drag the area or their edges on the screen. You can also enter the limits of the search zoom window in the "Search > Results Presentation" tab.
Be aware, that the zoom window settings are valid for all results of a search definition, so if you change the settings drastically for one result, they may not be correct for the next search result you switch to.
For details, see [chapter 5.2.2, "Zooming for Details"](#), on page 194.
3. The zoom area is indicated in the diagram that displays the source waveform of the search. The zoom window is displayed for the currently selected search result.
Directly after a search this is the first result that was found.
Select the result line in the result box for which you want to display the zoom window.

10.5 Noise Reject

Noise rejection for searches is very similar to noise rejection for triggers. You can reject noise by setting a hysteresis in order to avoid finding events caused by noise oscillation around the trigger level.

10.5.1 Noise Reject Settings

You can select the hysteresis mode and value for each analog and digital input channel, math and reference waveform.

The noise reject settings are similar to those for triggers, see also [chapter 4.3.3, "Noise Reject"](#), on page 166.

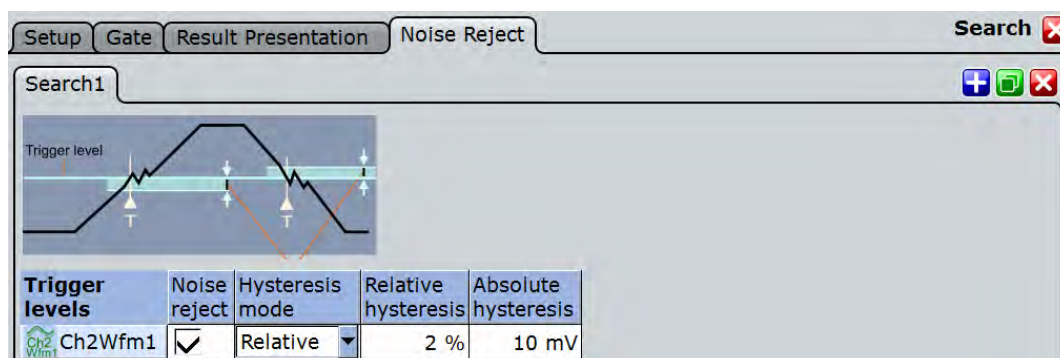

Noise reject

If enabled, the hysteresis is considered for the search.

Remote command:

[SEARCH:TRIGger:LEVel:NOISe\[:STATe\]](#) on page 907

Hysteresis mode

Defines whether values absolute or relative to the vertical scaling are used.

Remote command:

[SEARCH:TRIGger:LEVel:NOISe:MODE](#) on page 906

Relative / Absolute hysteresis

Defines a range in absolute or relative values around the search level. If the signal jitters inside this range and crosses the level, no search event is detected.

Absolute hysteresis values are adapted when the relative hysteresis is changed, and vice versa.

If you change the vertical scaling, either the relative or the absolute value is adjusted automatically.

Remote command:

[SEARCH:TRIGger:LEVel:NOISe:ABSolute](#) on page 906

[SEARCH:TRIGger:LEVel:NOISe:RELative](#) on page 907

10.5.2 Defining Noise Rejection for Searches

1. Press the SEARCH key to open the "Search" dialog box.
2. Select the "Noise reject" tab.
3. Select the tab for the search you want to configure.
4. Define the absolute or relative hysteresis. If you change one value, the other is automatically calculated.

11 Data and Results Management

This chapter describes how to manage measurement settings and results and other data.

- [Saving, Loading and Printing Data](#).....360
- [Reference for FILE Settings](#).....365
- [Reference for PRINT Settings](#).....387

11.1 Saving, Loading and Printing Data

After a measurement with the R&S RTO you would usually like to save the results for further evaluation or comparison. You can save the results of a measurement as a data file containing the waveform data, or print or save the current measurement display to a printer or a file. In order to repeat measurements at different times or perform similar measurements with different test data, it is useful to save the used instrument settings and load them again later. These tasks are described here.

- [Configuring Printer Output and Printing](#)..... 360
- [Saving and Loading Waveform Data](#)..... 361
- [Saving and Loading Settings](#)..... 362
- [Restoring Settings](#).....364
- [Defining Default File Paths and Names](#)..... 365

11.1.1 Configuring Printer Output and Printing

If you want to store the graphical results of the measurement, you can either print the current display on a printer or save an image to a file.

You can configure the format and colors used for printing, inverse the colors, and edit the image. A preview of the current print image is shown for reference.

1. Press the PRINT key to display the "Print" dialog box.
2. Tap the printer selection box to select the printer to use for printing.
3. Tap the "Color" selection box to configure black and white or color images.
4. Tap the "Orientation" selection box to select the paper format.
5. To enhance waveform printouts on white paper, enable the "Inverse color" option.
6. If the current display is likely to have changed since you opened the "Print" dialog box (e.g. due to a running measurement), tap the "Update image" button.
The current print image is updated.
7. In order to zoom into the image preview, enable the "Zoom" option beneath the preview area.

The image is enlarged and scrollbars are displayed to scroll through the print image.

8. To edit the image in an external application and process it further from there, tap the "Edit image" button.

The print image is opened in the Paint application. Edit the image as necessary, and store or print the file from there. Alternatively, save the file and close the Paint application to return to the "Print" dialog. Then print or save the (edited) image as described below. The changes are not shown in the preview.

9. To print the image to the selected printer, tap the "Print" button.
10. To save the print image to the specified file, tap the "Save" button.
To save it to a different file, tap the "Save As" button and select the file in the file selection dialog box.

11.1.2 Saving and Loading Waveform Data

You can save the data of a channel, math or reference waveform to an `.xml`, `.csv`, or `.bin` file. The data export of several channels into one file is also possible. Files in `.bin` format can be reloaded to the R&S RTO as reference waveforms.

Not only a complete waveform can be saved, but also a part of it, limited by a previously defined zoom, cursor lines, measurement gate or user-defined time values.

It is also possible to save history data to file. Furthermore, you can save a "live record" of a running RUN Nx SINGLE acquisition to one data file.

For details on waveform save/recall settings, see [chapter 11.2.2.2, "Waveforms - Export Settings"](#), on page 374.

The following procedures are described:

- ["To save a waveform or a part of a waveform to a file"](#) on page 361
- ["To export waveform data of a running acquisition"](#) on page 362
- ["To save the history"](#) on page 210
- ["To load a reference waveform"](#) on page 215
["To save a reference waveform"](#) on page 214

To save a waveform or a part of a waveform to a file

1. Press the FILE key.
2. Tap the "Waveforms/Results" tab.
3. Tap the "Waveforms" sub-tab.
4. Select the waveform(s) to be saved:
 - To save one waveform, tap the "Source" icon and select the waveform.
 - To save data of several channels, enable "Multi channel" and select the channels.

5. In the "Scope" list, select the part of the waveform record to be saved. Zoom, cursor and gate segments require the according setup for the selected waveform before saving. For "Manual", enter the "Start" and "Stop" time of the section.
6. Check the file name under "Save to file" and change it if needed. Usually, auto-naming is used.
7. Check the file format and the "Export format" settings and change them if needed.
8. Tap "Save" to save the waveform data to the specified file.
Tap "Save As" to save the waveform data to a different file or file type. Select the file from the file selection dialog box.

To export waveform data of a running acquisition

1. Select the waveform(s) to be saved and the scope as described in ["To save a waveform or a part of a waveform to a file"](#) on page 361, step 1 to 5.
2. If you want to save only a section of each waveform, set the "Scope".
3. Enable "Data logging".
4. Enter the number of acquisitions to be acquired and saved in "Acq count".
5. Check the file name under "Save to file" and change it, if needed. Usually, auto-naming is used.
6. Tap "Start Export" to start the acquisition and to save the acquired waveform data to the specified file.

To load waveform data as a reference waveform

In order to re-load waveform data from a previous measurement, the waveform must have been stored as a reference waveform in a BIN file before.

The procedure is described in ["To load a reference waveform"](#) on page 215

11.1.3 Saving and Loading Settings

In order to repeat measurements at different times or perform similar measurements with different test data, it is useful to save the used instrument settings and load them again later. Furthermore, it can be helpful to refer to the instrument settings of a particular measurement when analyzing the results. Therefore, you can easily save the instrument settings of a measurement. In addition to the measurement-related settings, user-specific settings concerning the display and data management can also be saved and loaded.

Settings can be stored in a file with user-defined name and location, or in a quick save-set. The settings in a saveset can be saved and retrieved very quickly at the touch of a button, so savesets are ideal for frequently used measurements.

For details on save/recall instrument settings and associated remote commands, see [chapter 11.2.1.1, "Settings"](#), on page 366.

To save instrument settings in a SaveSet

1. Press the FILE key.
2. Select the "Save/Recall" tab.
3. Select the "Settings" tab.
4. Tap one of the three available "Save" buttons in the "Quick savesets" area.

The current instrument settings are saved in the selected SaveSet.

To load instrument settings from a SaveSet

1. Press the FILE key.
2. Select the "Save/Recall" tab.
3. Select the "Settings" tab.
4. Tap the required "Recall" button in the "Quick savesets" area.

The saved settings are loaded to the R&S RTO.

**Restoring Default Settings**

After loading saved instrument settings, you can restore the default settings by pressing the PRESET key or the "Factory Defaults" button in the "User Defined Preset" tab. For details see [chapter 11.1.4, "Restoring Settings"](#), on page 364.

To save settings to a file

1. Press the FILE key.
2. Select the "Save/Recall" tab.
3. Select the "Settings" tab to save instrument settings, or the "User Preferences" tab to save user-specific settings.
4. Tap "Save" to save the settings to the specified file.
Tap "Save As" to save the settings to a different file. Select the file from the file selection dialog box.

The current settings are saved to the selected file.

To load settings from a file

1. Press the FILE key.
2. Select the "Save/Recall" tab.
3. Select the "Settings" tab to load instrument settings, or the "User Preferences" tab to load user-specific settings.
4. Tap "Load" to load the settings from the specified file.

Tap "Open" to load the settings from a different file. Select the file from the file selection dialog box.

The saved settings are loaded to the R&S RTO.

11.1.4 Restoring Settings

When you have changed many different settings on the instrument and are no longer sure which settings are causing which effect in the measurement, you may want to restore the default settings and start anew. Depending on the situation and which data is to be restored, the following methods are available:

- Restoring the instrument settings to their default values
- Restoring settings from a file (see ["To load settings from a file"](#) on page 363)
- Restoring the default instrument settings and user-specific settings to a saved state in one step during one measurement session
- Restoring all settings on the R&S RTO to the factory-defined values

For details on save/recall instrument settings and associated remote commands, see [chapter 11.2.1.1, "Settings"](#), on page 366.

To restore the instrument settings to their default values

- ▶ Press the PRESET key.

The instrument settings are restored to their default values.

To restore the default instrument settings and user-specific settings to a saved state in one step

This method is only available during one measurement session.

1. Press the FILE key.
2. Select the "Save/Recall" tab.
3. Select the "User-defined preset" tab.
4. Tap the "Save" button to save the current user-specific settings temporarily in a SaveSet. The SaveSet remains available until you switch off the instrument, then it is deleted.
5. Enable the "Enable user-defined preset" option.
6. At any time during the same measurement session, press the PRESET key.

The instrument settings are reset to their default values, the user-specific settings are reset to the values saved in the SaveSet.

To restore all settings on the R&S RTO to the factory-defined values

1. Press the FILE key.
2. Select the "Save/Recall" tab.

3. Select the "User-defined Preset" tab.
4. Tap the "Factory defaults" button.

All settings on the R&S RTO are reset to their factory-defined values.

11.1.5 Defining Default File Paths and Names

When a save or load operation is performed, a default file name and path is provided. You can configure which path is used and how the file name is generated. In the file selection dialog box you can change the folder and name as desired.

To define the default file path

1. Press the FILE key.
2. Select the "Autonaming" tab.
3. Double-tap the "Default path for all file operations" field.
The directory selection dialog box is opened.
4. Select the folder in which the data is to be stored by default.
5. To restore the factory-set default path, tap "Reset" next to the path field.

To define the automatic file name pattern

The automatic file name pattern can consist of the following elements:

<Prefix>_<UserText>_<Date>_<Index>_<Time>

The prefix depends on the data type to be stored and cannot be changed by the user. The other elements can be enabled or disabled as required.

1. Press the FILE key.
2. Select the "Autonaming" tab.
3. To insert a user-defined text after the prefix, enter the text in the edit field.
4. To insert the current date, time or an index (serial number), enable the corresponding option.

The specified elements are used to generate the default file name for the next storage operation.

11.2 Reference for FILE Settings

The FILE key provides functions for saving and restoring data on the instrument. The following types of data can be saved and loaded:

- Instrument and measurement settings
- User-specific display settings

- Preset values
- Waveform data
- Histogram data
- Results

A naming pattern is available and can be adjusted to simplify a clear data storage.

- [Save/Recall](#)..... 366
- [Waveforms / Results](#)..... 368
- [Autonaming](#)..... 385
- [File Selection Dialog](#)..... 386

11.2.1 Save/Recall

In this tab you define the storage settings for each type of data to be saved.

For information on data export in I/Q mode (option R&S RTO-K11), see [chapter 16.3, "I/Q Data Output"](#), on page 541.

- [Settings](#)..... 366
- [User Preferences](#)..... 367
- [User-defined Preset](#)..... 368

11.2.1.1 Settings

In this tab, the storage configuration for instrument settings is defined. These settings contain the complete instrument and measurement configuration except for user-specific display settings stored as "User Preferences". You can save an unlimited number of setting files. For the most frequently used measurements, store the settings in "Quick savesets" and recall them very quickly.

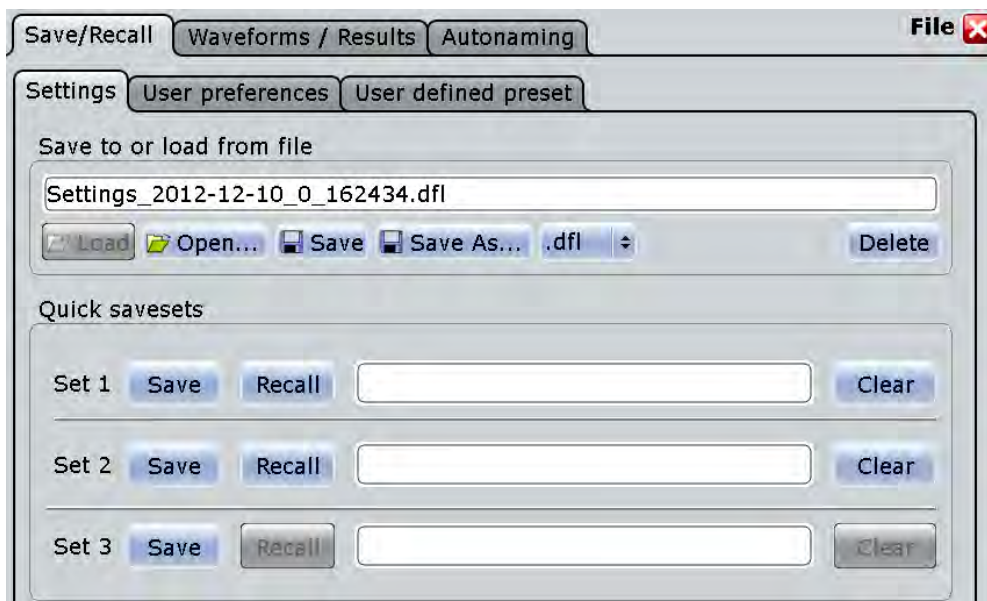

Save to or load from file

Enter the file name to load or to save the setting data to, and select the file format with the format button on the right. Double-tap the file name to open the file selection dialog box. See also: [chapter 11.2.4, "File Selection Dialog"](#), on page 386.

By default, settings file names have the prefix "Settings_".

"Load"	Loads the specified file.
"Open"	Opens a file selection dialog box and loads the selected file.
"Save"	Saves the data to the selected file.
"Save As..."	Opens the file selection dialog box and saves the data to the selected file.
".dfi/.xml"	Selects the file format.
"Delete"	Deletes the selected file.

Remote command:

[MMEemory:SAV](#) on page 919

[MMEemory:RCL](#) on page 919

Quick savesets

A saveset stores the current measurement and instrument settings at the touch of a button, and reloads them in the same way. Three savesets are available for the most frequently used measurements.

Savesets are stored automatically with standard names, so it is useful to describe the settings in a comment.

"Save"	Saves the current measurement and instrument settings to one of the three savesets.
"Recall"	Loads the instrument settings from one of the three savesets.
"Comment"	Double-tap the edit field to describe the settings saved in the selected saveset.
"Clear"	Deletes the selected saveset.

11.2.1.2 User Preferences

In this tab, the storage settings for user-specific display settings (diagram layout, toolbar, and transparency settings) are defined. By default, these file names have the prefix "UserPreferences_".

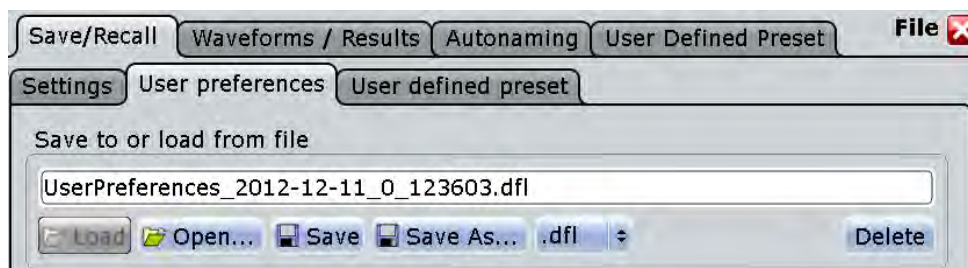
**Save to or load from file**

The file name to load or to save the data to.

By default, user preference file names have the prefix "UserPreferences_".
For details, see the [Save to or load from file](#) function in the "Settings" tab.

11.2.1.3 User-defined Preset

A user-defined preset contains the complete instrument setup including display settings, except for transparency and intensity. You can save the current configuration to a preset file, and load a previously saved preset file. You can then specify that these settings are to be applied, in addition to the standard instrument settings, with the PRESET function.

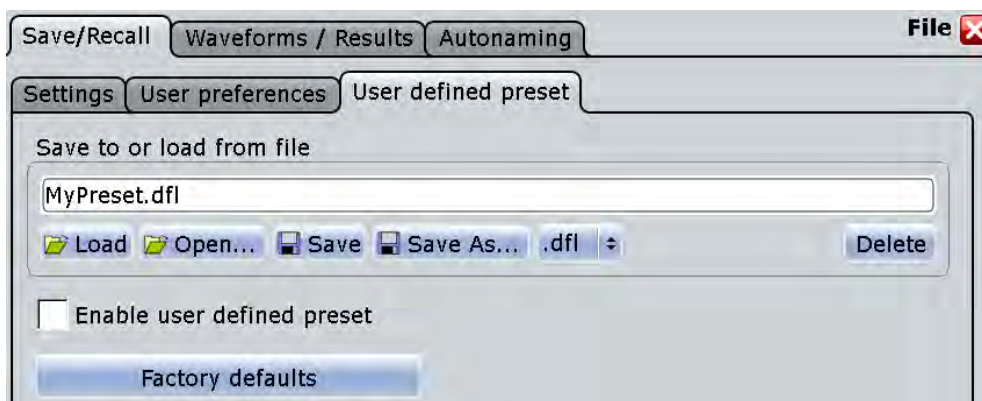

Save to or load from file

The file name with extension .dfl to load or to save the settings to.

For details, see the [Save to or load from file](#) function in the "Settings" tab.

Enable user-defined preset

If enabled, the settings from the selected preset file are restored when the PRESET key is pressed.

If disabled, PRESET sets the instrument to the factory defaults.

Factory defaults

Resets the instrument to the factory default settings, to the initial state. Factory settings comprise all instrument settings, including display, intensity and transparency settings. After loading factory defaults, perform a self-alignment to synchronize the signal data ("File" menu > "Selfalignment").

Remote command:

[SYSTem: PRESet](#) on page 934

11.2.2 Waveforms / Results

- [Waveform File Formats](#).....369
- [Waveforms - Export Settings](#).....374
- [Waveform Histograms](#).....379
- [Numeric Results](#).....381
- [Long Term / Meas Histograms](#).....382

11.2.2.1 Waveform File Formats

Waveforms can be stored in XML, CSV, or BIN format.



Reloading waveforms

In order to reload waveform data as a reference waveform, it must be stored in BIN format.

If multiple channels are exported, reloading is not possible.

If multiple acquisitions of one waveform are exported (Data logging or Multiple waveforms), only the first acquisition can be reloaded.

If the signal is a spectrum, reloading is only possible for waveforms with "Magnitude unit" = Linear. Waveforms with logarithmic unit cannot be reloaded.

Data of all waveforms is saved in two files. One file contains the waveform data values and is indicated by *Wfm.* in the file name. The second file contains the header data, for example, time scale, vertical scale, vertical and horizontal positions, interpolation mode and much more. Header data is required to restore the waveform from data, or to analyze the data values of the data file.

Header Files

The header files of XML and BIN waveform files are written in XML format. The header files of CSV waveform files are written in CSV format. You can open the header files and use their information for data analysis.

CSV header files only contain the property names and values, one property per row.

```
Resolution:1e-010:
RecordLength:1000:
```

XML header files contain more information than CSV header files. The additional information is required to reload the stored waveforms with their correct settings.

```
<Prop Avail="0" ValueKey="" Name="Resolution" Value="1e-010" UserValue="0"
Step="1e-011" Default="0" Min="0" Max="1e+026" StepDefault="1e-011"
StepFactor="10" Resolution="0" UnitId="55" UnitName="s" UnitPowerProduct=""
BitGroupSize="0" Format="0"></Prop>

<Prop Avail="0" ValueKey="" Name="RecordLength" Value="1000" UserValue="1000"
Step="1" Default="1000" Min="0" Max="4294967295" StepDefault="1" StepFactor="10"
Resolution="1" UnitId="93" UnitName="Sa" UnitPowerProduct="" BitGroupSize="0"
Format="0"></Prop>
```

Header files contain the following properties:

Table 11-1: Header file properties

Value	Description
General	
FirmwareVersion	Firmware version that is installed on the R&S RTO (last entry in the header file)

Value	Description
Source	Name of the exported waveform
MultiChannelExport	Indication whether multiple channels are exported simultaneously
Resolution	Time between two samples <i>Resolution = 1 / Sample Rate</i>
SignalResolution	Time between two samples in this waveform. The value can differ from Resolution if the source is, for example, a spectrum, a bus signal, a correlation or a measurement. The value is determined automatically considering the waveform parameters and their dependencies. If the signal is a spectrum, the value indicates the frequency range of FFT bins.
EnhancementMode	Method to increase the sample rate if the required sample rate is higher than the ADC sample rate.
InterpolationMode	Interpolation method. The value is relevant when the enhancement mode is interpolated time.
DecimationMode	Method to reduce the number of data samples to achieve the required sample rate
DecimationFactor	Factor to the number of data samples to achieve the required sample rate <i>Decimation factor = ADC sample rate / Sample rate</i>
TraceArithmetics	Off, Envelope, or Average
InterleavedTraceCount	Number of y-values saved at each sampling time. The value is usually 1. The value is 2, if min and max values are saved for each sample, for example, for envelope waveforms.
Record length	
RecordLength	Number of samples in a waveform record of one acquisition
HWRRecordLength	Equivalent to the RecordLength
SignalRecordLength	Number of required samples in the waveform. The value can differ from RecordLength and HWRRecordLength if the source is, for example, a spectrum, a bus signal, a correlation or a measurement. The value is determined automatically considering the waveform parameters and their dependencies. If the signal is a spectrum, the value indicates the number of FFT bins.
SignalHardwareRecordLength	Number of samples actually available in this waveform, including the number of required samples in the waveform and the additional samples needed for further computation
LeadingSettlingSamples	Number of additional samples before the beginning of waveform samples. These additional samples are needed for further computation, for example, for filters.
Horizontal system	
TimeScale	Horizontal scale in seconds per division
HorizontalDivisionCount	Number of horizontal divisions
RescaleCenterTime	Horizontal position, the time distance between the reference point and the zero point of the diagram
RescaleCenterPoint	Position of the reference point in % of the screen

Value	Description
ReferencePoint	Position of the zero point in % of the screen
TriggerOffset	Time distance from the trigger point to the zero point of the diagram
Horizontal waveform parameters	
XStart	Horizontal start value of the waveform (time or frequency) *)
XStop	Horizontal stop value of the waveform (time or frequency)
HardwareXStart	Actual horizontal start value of data, including the settling time for further computation *)
HardwareXStop	Actual horizontal stop value of data, including the settling time for further computation
	*) If the waveform is a spectrum, the XStart and HardwareXStart values may be slightly smaller than the specified start frequency, or even get negative. The spectrum is centered on the center frequency, and the frequency range covered by one spectral bin is given by the SignalResolution. Hence, the spectral bin in the center of the spectrum always covers the range [CenterFrequency; CenterFrequency + SignalResolution]. As a result, the range covered by the first spectral bin in the spectrum may reach further than the start frequency specified by the user. It is ensured that the specified start frequency is included in the frequency range.
Vertical system	
VerticalScale	Vertical scale of the waveform in Volts per division, or other unit / division
VerticalDivisionCount	Number of vertical divisions
VerticalPosition	Vertical position of the waveform in divisions
VerticalOffset	Vertical offset of the waveform in Volts, or other unit
NofQuantisationLevels	Theoretical number of quantization levels in the signal. This value depends on the waveform format (8 bit, 16 bit, ...). In case of a math waveform, it depends on the quantization levels of the operands and on the operator type.
Vertical waveform parameters	
BaseYStart	Vertical start value of the waveform
BaseYStop	Vertical stop value of the waveform
Math waveform	
BaseUnit	Base unit of a mathematic waveform, for example, linear unit
ViewUnit	User-selected unit of a mathematic waveform, for example, logarithmic unit for a spectrum. The value is only valid if the exported waveform is a math waveform.
ViewUnitRelative	Indication of a relative unit. It is true if the math waveform has the ViewUnit "dB", for example. The value is only valid if the exported waveform is a math waveform.
ViewReferenceLevel	Reference level for a relative unit. The value is only valid if the exported waveform is a math waveform, and the unit is relative.
FFT	
CenterFreq	Center frequency of the spectrum

Value	Description
FreqSpan	Frequency span of the spectrum
FrequencyStart	Start frequency of the spectrum
FrequencyStop	Stop frequency of the spectrum
WindowType	Window used for the spectrum computation
ResolutionBW	Resolution bandwidth of the spectrum
AdjustedResolutionBW	Actual resolution bandwidth of a spectrum waveform. The value is only valid if the exported waveform is a spectrum.
GateRBWCoupling	Indication whether the record length or the resolution bandwidth is a constant for the spectrum computation
Parameters for power calculation	
Impedance	Impedance used for power calculation
NoiseBandwidth	Noise bandwidth of a spectrum waveform, required for power calculation. The value is only valid if the exported waveform is a spectrum.
Parameters for internal use	
SourceType	Source qualifier
TraceType	Waveform qualifier
ValueType	
TOADone	
BaseUnitRelative	Base unit indication
UseInterSampleTriggerOffset	
ISO_TRG SC_POST SC_TRG	

Waveform Value Files

The waveform value files - indicated by `*Wfm.*` in the file name - contain the actual waveform data. Usually only Y-values - mostly voltage values - are written subsequently. If the signal is a spectrum, the data of the last frame is written.

If the waveform consists of minimum and maximum values, two Y-values per sample are written, and the property `InterleavedTraceCount` in the header file is `>1`. This applies to envelope waveforms, for example.

The option "Interleaved X/Y" allows you to include horizontal values into the file.

At multi-channel export, the Y-values of the selected channels are written in interleaved order.

- One channel, single acquisition export
 - Normal waveform:
 $Y_0; Y_1; Y_2; Y_3; \dots$
 - Envelope waveform:

- Ymin₀; Ymax₀; Ymin₁; Ymax₁; Ymin₂; Ymax₂; Ymin₃; Ymax₃; ...
- Normal waveform, interleaved x/y data:
X₀; Y₀; X₁; Y₁; X₂; Y₂; X₃; Y₃; ...
 - Envelope waveform, interleaved x/y data:
X₀; Ymin₀; Ymax₀; X₁; Ymin₁; Ymax₁; X₂; Ymin₂; Ymax₂; X₃; Ymin₃; Ymax₃; ...
 - Multi-channel, single acquisition export
In the example, two channels are exported.
 - Normal waveforms:
YCh1₀; YCh2₀; YCh1₁; YCh2₁; YCh1₂; YCh2₂; YCh1₃; YCh2₃; ...
 - Envelope waveforms, channel 1 and channel 2 are envelopes:
YCh1min₀; YCh1max₀; YCh2min₀; YCh2max₀; Ymin₁; Ymax₁; YCh2min₁;
YCh2max₁; Ymin₂; Ymax₂; YCh2min₂; YCh2max₂; Ymin₃; Ymax₃; YCh2min₃;
YCh2max₃; ...
 - Normal waveforms, interleaved x/y data:
X₀; YCh1₀; YCh2₀; X₁; YCh1₁; YCh2₁; X₂; YCh1₂; YCh2₂; X₃; YCh1₃; YCh2₃; ...
 - Envelope waveform and normal waveform, interleaved x/y data:
X₀; YCh1min₀; YCh1max₀; YCh2₀; X₁; YCh1min₁; YCh1max₁; YCh2₁; X₂;
YCh1min₂; YCh1max₂; YCh2₂; X₃; YCh1min₃; YCh1max₃; YCh2₃; ...

In XML and CSV waveform value files, the data of each sample is grouped. The example shows the values of two samples for two waveforms and interleaved x/y data. The first waveform is an envelope, the second one is a normal waveform.

In CSV files, the data values for a given sampling time is written in one row.

```
-1.96e-008    -0.0079051387    -0.0059288535    -0.1027668
-1.95e-008    -0.0098814229    -0.0079051387    -0.10474309
```

In XML format, an empty line marks the beginning of the next sample.

```
<Data>-1.96e-008</Data>
<Data>-0.0079051387 </Data>
<Data>-0.0059288535 </Data>
<Data>-0.1027668 </Data>

<Data>-1.95e-008</Data>
<Data>-0.0098814229 </Data>
<Data>-0.0079051387 </Data>
<Data>-0.1027668 </Data>
```

If multiple acquisitions (Data logging / Multiple waveforms) are exported, the first acquisition is written in the same way as with single acquisition export. The following acquisitions are appended in the same way. If the signal is a spectrum, the last frame of each acquisition is saved.

Before and after the waveform data, the instrument writes some leading and trailing settling samples. They ensure that all measurements can be performed on the reloaded waveform that could be performed on the original waveform. The number of leading settling samples is provided in the header file.

Number of Samples in the Export File

In this section, a sample is defined as one or more values acquired at a given sampling time. The number of samples for one channel and acquisition is given in the header file by the property `SignalHardwareRecordLength`. This number includes the number of required samples in the waveform and additional samples at the beginning (leading samples) and the end of the file (trailing samples).

The number of additional samples is:

$$\text{No of additional samples} = \text{SignalHardwareRecordLength} - \text{SignalRecordLength}$$

The number of leading additional samples is given in the header file:

`LeadingSettlingSamples`.

The number of trailing additional samples is:

$$\begin{aligned} \text{No of trailing additional samples} &= \text{No of additional samples} - \text{LeadingSettlingSamples} \\ &= \text{SignalHardwareRecordLength} - \text{SignalRecordLength} - \text{LeadingSettlingSamples} \end{aligned}$$

If the waveform has more than one Y-value per sample (e.g. envelope), the property `InterleavedTraceCount` is > 1 , and the number of values in the file for this waveform is:

$$\text{No of values per waveform} = \text{InterleavedTraceCount} * \text{SignalHardwareRecordLength}$$

If multiple acquisitions are exported, the total number of values in the file is:

$$\text{No of values} = \text{InterleavedTraceCount} * \text{SignalHardwareRecordLength} * \text{No of exported acquisitions}$$

If "Interleaved x/y" is enabled, one horizontal value is added per sample. The total number of values in the file is:

$$\text{No of values} = (1 + \text{InterleavedTraceCount}) * \text{SignalHardwareRecordLength} * \text{No of exported acquisitions}$$

MSO option R&S RTO-B1:

If the data of digital channels is stored in BIN format, one bit is written for each sample. 8 data samples are written in one byte (data word). For example, 100 MSa are written into a 12.5 MByte BIN file. After reading the file, you have to extract the samples from the data words.

11.2.2.2 Waveforms - Export Settings

In this tab, the storage settings for waveform data are defined.

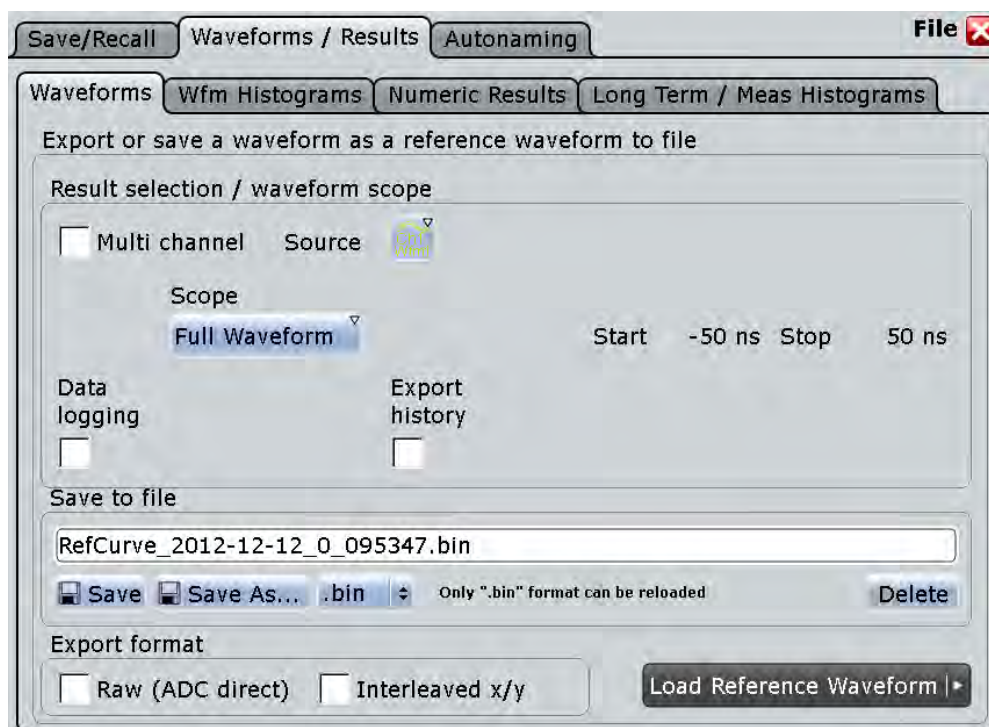

See also: [chapter 11.1.2, "Saving and Loading Waveform Data"](#), on page 361.

For details of data export in I/Q mode (option R&S RTO-K11), see [chapter 16.3, "I/Q Data Output"](#), on page 541.

Multi-channel export

Enables or disables the export of multiple input channels. If enabled, you can export the data of selected input channels ([Selected sources](#)) into one file. Reloading the exported waveforms is not possible, regardless of the selected file format.

If disabled, you can export one [Source](#) waveform.

Remote command:

[EXPort:WAVeform:MULTichannel](#) on page 921

Source

Selects the waveform to be exported if "Multichannel export" is disabled. Active waveforms of input channels, math signals and reference waveforms are available for export.

If the MSO option R&S RTO-B1 is installed, you can save also digital channels.

Remote command:

[EXPort:WAVeform:SOURce](#) on page 921

Selected sources

Select the channels to be included in data export if "Multichannel export" is enabled. Waveform1 of up to four input channels can be saved into one file.

Result selection / waveform scope					
<input checked="" type="checkbox"/> Multi channel	Selected sources	Channel 1	Channel 2	Channel 3	Channel 4
		<input checked="" type="checkbox"/>	<input type="checkbox"/>	<input checked="" type="checkbox"/>	<input type="checkbox"/>

Remote command:

[CHANnel<m>:EXPortstate](#) on page 922

Scope

Defines the part of the waveform record that has to be stored.

- "Full wave-
form" Saves the complete waveform record.
- "Zoom" Saves the data included in the zoom area if at least one zoom is defined for the source waveform. The start and stop values of the area are shown. If several zooms are defined, select the "Zoom" to be used for export.
- "Cursor" Saves the data between the cursor lines if at least one cursor measurement is defined for the source waveform. The start and stop values of the area between the cursor lines are shown. If several cursor sets are defined, select the "Cursor set" to be used for export.
- "Gate" Saves the data included in the measurement gate if a gated measurement is defined for the source waveform. Select the "Measurement" for which the required gate is defined. The start and stop values of the gate are shown.
- "Manual" Saves the data between user-defined "Start" and "Stop" values.

Remote command:

[EXPort:WAVeform:SCOPE](#) on page 922

[EXPort:WAVeform:START](#) on page 923

[EXPort:WAVeform:STOP](#) on page 923

[EXPort:WAVeform:ZOOM](#) on page 923

[EXPort:WAVeform:CURSorset](#) on page 923

[EXPort:WAVeform:MEAS](#) on page 924

Data logging / Multiple Wfms

The "Data logging / Multiple Wfms" setting enables the export of subsequent acquisitions of the selected waveforms. If "Export history" is disabled, the setting is named "Data logging", and it exports the data of a running Nx Single acquisition. If "Export history" is enabled, the setting is named "Multiple Wfms", and it exports the history waveform data to file.

If multiple acquisitions of one waveform are exported into a BIN file, the first acquisition can be reloaded as reference waveform.

"Data logging" enables the export of all waveforms of an Nx Single acquisition into one file. The waveform records are written in historical order one after the other, either the complete records or the sections as defined in "Scope". Set the number of acquisitions to be acquired and stored with "Acq. count". The maximum amount of data that can be written is shown in "Max. file size".

Enabling "Data logging" stops a running acquisition. To start the logging, tap [Start Export](#) or press RUN N× SINGLE.

Pressing "Run cont" disables data logging.

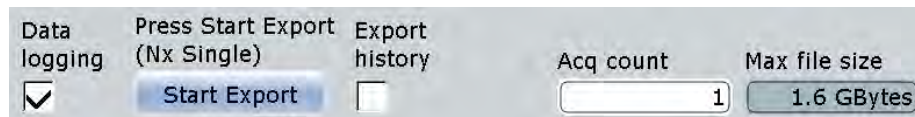

If "Export history" is enabled, the option "Multiple Wfms" allows you to save several or all history waveforms. Define the part of the history to be exported using "Start acq" and "Stop acq".

Remote command:

[EXPort:WAVeform:DLOGging](#) on page 924

Start Export

Starts an Nx Single acquisition series and simultaneously saves the waveform data to a file.

If "Export history" is enabled, the button starts the history replay and simultaneously saves the history waveforms.

Remote command:

[RUNSingle](#) on page 676 (Nx Single acquisition)

[CHANnel<m>\[:WAVeform<n>\]:HISTory:PLAY](#) on page 773 (History export)

Export history

Enables the history mode and the export of history waveforms to file. The setting is also available in the "History" dialog box under the designation "Show history".

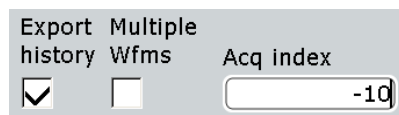

To save one waveform from the history, enter the number of the required acquisition in "Acq index".

To save several subsequent history waveforms, enable "Multiple Wfms" and define the range of the waveforms to be saved using "Start acq" and "Stop acq". These range settings are also available in the "History" dialog box.

Start the history replay and simultaneous saving with "Start Export".

Remote command:

[CHANnel<m>\[:WAVeform<n>\]:HISTory\[:STATe\]](#) on page 771

[CHANnel<m>\[:WAVeform<n>\]:HISTory:START](#) on page 772

[CHANnel<m>\[:WAVeform<n>\]:HISTory:STOP](#) on page 772

Save to file

Enter the file name to save the waveform to. Double-tap the file name to open the file selection dialog box.

By default, the file name has the prefix "RefCurves_". You can define a pattern for automatic naming in the "Autonaming" tab.

- "Save" Saves the waveform as a reference waveform in the selected file.
- "Save As..." Opens the file selection dialog box and saves the waveform to the selected file. See also [chapter 11.2.4, "File Selection Dialog"](#), on page 386
- ".bin/.xml/.csv" Selects the file format. Note that reference waveforms can be loaded from `.bin` files only.
See also: [chapter 11.2.2.1, "Waveform File Formats"](#), on page 369.

Remote command:

`EXPort:WAVeform:NAME` on page 921

`EXPort:WAVeform:SAVE` on page 921

Interleaved x/y

Includes horizontal values in the export data (time or frequency values, depending on the waveform). X and Y-values are written alternately to the file. If disabled, only Y-values - mostly voltage values - are written.

Interleaved x/y data cannot be exported as raw values, the "Raw (ADC direct)" option is not available.

The setting is not available for the export of digital channel data.

Remote command:

`EXPort:WAVeform:INCXvalues` on page 925

Raw (ADC direct)

Enables the export of data in the raw sample format of the ADC. The data format is integer 8 bit. This format reduces the file size (1 Byte/sample instead of 4 Bytes/sample in binary files) but decreases the precision of the values.

Only y-values are exported, the "Interleaved x/y" option is not available.

Currently, the setting is not available for the export of digital channel data.

Data conversion:

To convert INT8 data to physical quantities, e.g. voltages, use the following formulas:

$$\text{ConversionFactor} = \text{VerticalScale} * \text{VerticalDivisionCount} / \text{NofQuantisationLevels}$$

$$\text{PhysicalQuantity} = (\text{Value_ADC} * \text{ConversionFactor}) + \text{VerticalOffset}$$

The raw values are written in the `*.Wfm.*` file, all other values can be found in the corresponding header file.

VerticalScale	0.05
NofQuantisationLevels	253
VerticalDivisionCount	10
Value_ADC	-61

ConversionFactor	$0.05 * 10 / 253 = 0,00197628$
Voltage	$(-61 * 0,00197628) + 0 = -120,5 \text{ mV}$

Remote command:

[EXPort:WAVeform:RAW](#) on page 925

[FORMat \[:DATA\]](#) on page 673 (FORM:DATA INT, 8)

11.2.2.3 Waveform Histograms

Access: FILE > "Waveforms/Results > Wfm Histograms"

The waveform histogram export saves data in two files. The * .Wfm. * file contains 256 or 512 absolute or relative histogram values. The other file is the header file.

Contents of the header file:

- Source waveform of the histogram
- Histogram mode: vertical or horizontal
- Incidence of exported values: absolute or relative
- Histogram range: XStart, XStop, YStart, YStop
- Name of the exported histogram

Data conversion:

Using the header data, you can calculate the waveform value to which a histogram value belongs:

$$YValue = (YStop - YStart) / HistogramValuesCount * HistogramValueNumber + YStart$$

YStart	-0.25 V
YStop	0.25 V
HistogramValuesCount	256 (total number of written rows in an CSV file)
HistogramValueNumber	68 (number of the row in an CSV file)
Y-Value	$(0.25 - (-0.25)) / 256 * 68 - 0.25 = -0.11719 \text{ V}$

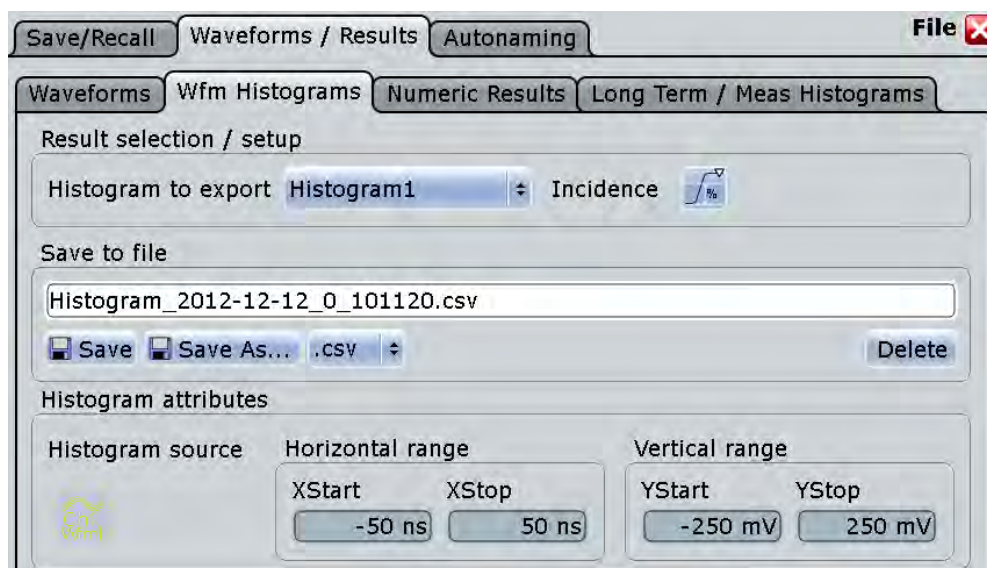

Histogram to export

Selects the histogram to be exported. All active waveform histograms are shown in the list.

Measurement histograms can also be exported, see [chapter 11.2.2.5, "Long Term / Meas Histograms"](#), on page 382.

Remote command:

[EXPort:HISTogram:SElect](#) on page 926

Incidence

Sets the mode of exported histogram data: relative or absolute count of values. If relative values are exported, the sum of all values is 1, and the count of each value is set in relation to the sum.

Remote command:

[EXPort:HISTogram:INCidence](#) on page 927

Save to file

Enter the file name to save the waveform histogram to. Double-tap the file name to open the file selection dialog box.

By default, the file name has the prefix "Histogram_". You can define a pattern for automatic naming in the "Autonaming" tab. The default directory is:

Windows XP:

C:\Documents and Settings\All Users\Documents\Rohde-Schwarz\RTO\Histograms.

Windows 7:

C:\Users\Public\Documents\Rohde-Schwarz\RTO\Histograms

"Save" Saves the histogram data in the selected file.

"Save As..." Opens the file selection dialog box and saves the histogram data to the selected file. See also [chapter 11.2.4, "File Selection Dialog"](#), on page 386

".bin/.xml/.csv" Selects the file format.

Remote command:

[EXPort:HISTogram:NAME](#) on page 927

[EXPort:HISTogram:SAVE](#) on page 927

[EXPort:HISTogram:DATA?](#) on page 927

Histogram source, Horizontal range, Vertical range

Show the source and the limits of the histogram area for information. The ranges are set in the "Histogram" dialog box ("Meas" menu > "Histogram"). See also: [chapter 7.2.4.13, "Histogram Setup"](#), on page 285.

11.2.2.4 Numeric Results

In this tab, you can select the result boxes to be saved, and define the storage settings.

Access: FILE > "Waveforms/Results > Numeric Results"

Access to the tab is also available in all tabs where measurement and analysis settings are defined, for example, in the "Measurements Setup", "Cursors Setup", and "Masks Test Definition" tabs: Simply tap the "Result Export" button.

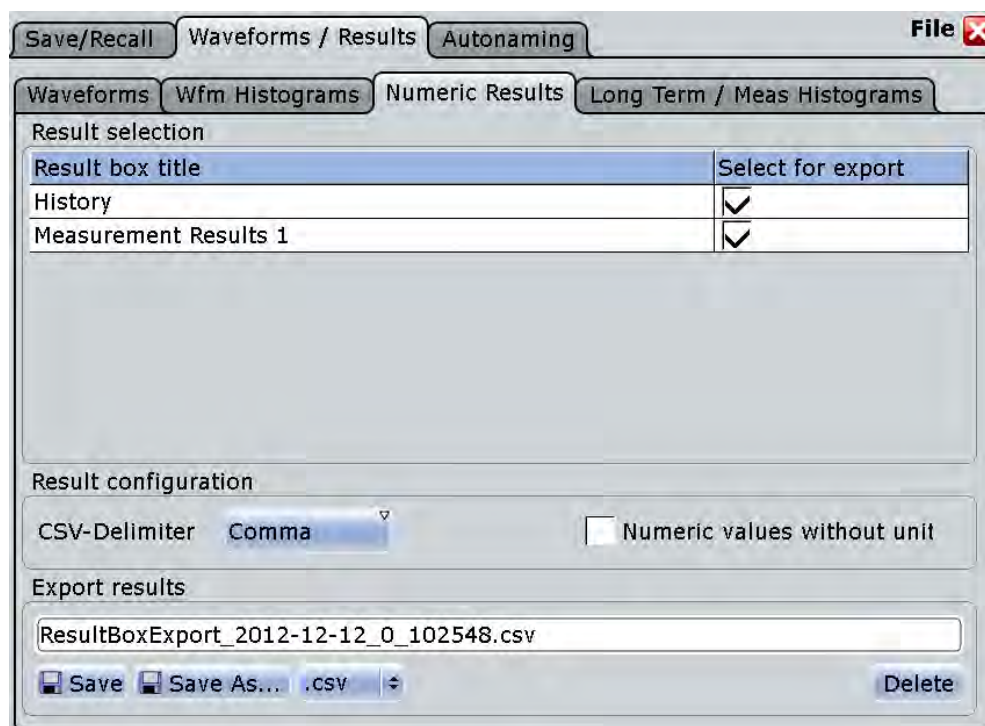

Result selection

The table lists all result boxes that are currently open, including minimized boxes and docked boxes. Select the results that you want to save to file. All results are written into one file.

Note: If the result box is minimized, only the columns shown on the result icon are saved (2 columns). Statistical results are not shown on the minimized results icon, and they are not saved.

CSV-Delimiter

Selects the value delimiter that is used to convert the values in columns. For MS Excel, the semicolon is recommended to be used.

Numeric values without unit

By default, numeric result values are written with their unit to the file. If the option is enabled, the values are saved with more decimal places.

Export results

Enter the file name to save the results to. Double-tap the file name to open the file selection dialog box.

By default, the file name has the prefix "ResultBoxExport_". You can define a pattern for automatic naming in the "Autonaming" tab.

- | | |
|--------------|---|
| "Save" | Saves the selected results to the indicated file. |
| "Save As..." | Opens the file selection dialog box and saves the selected results to the selected file. See also chapter 11.2.4, "File Selection Dialog" , on page 386 |
| ".csv/.html" | Selects the file format. <ul style="list-style-type: none"> • CSV: Comma-Separated Values.
You can select the value delimiter with "CSV-Delimiter" to ensure that the file can be read by the analyzing software. The decimal separator is the point.
Tipp for using MS Excel: It is recommended that you use the semicolon as csv delimiter. When you open the file with MS Excel, use "File > Open" and follow the wizard to set the separators correctly, or set the separator settings with "Tools > Options > International". • HTML: Results are saved as web page for display in a browser. |

11.2.2.5 Long Term / Meas Histograms

Access: FILE > "Waveforms / Results > Long Term / Meas Histograms"

You can export the data of long term measurements and the measurement histogram data to file .

The measurement export saves results in two files. The *.Wfm.* file contains data values, and the other file is the header file.

The header file contains:

- Source waveform of the measurement
- Measurement scale
- Export type = Histogram or Long term
- Exported measurement

- Histogram range: XStart, XStop, YStart, YStop
The range is only relevant for export type = histogram. The measurement axis is the X-axis, which can be a horizontal or vertical axis depending on the histogram mode.

Long term measurements: The *.Wfm.* file contains one value or value set for each long term measurement point. The maximum number of points is defined in the "Horizontal scaling" dialog box.

- If statistics are disabled, the current result of the main measurement is written - one double value per long term point.
- If statistics are enabled, six values for each long term point are saved:
 - Upper peak
 - Lower peak
 - Average
 - Standard deviation
 - Event count per point: number of measurement results that creates one long term point
 - Waveform count per point: number of waveforms included in one long term point.

Measurement histogram: The *.Wfm.* file contains 1000 absolute or relative histogram values.

Data conversion of measurement histogram data:

Using the header data, you can calculate the measurement value to which a histogram value belongs:

$$\text{MeasValue} = (\text{XStop} - \text{XStart}) / 1000 * \text{HistogramValueNumber} + \text{XStart}$$

Example: The 273rd histogram value is 0.491749. That means, the relative frequency of the measurement value 0.1246 V is 0.491749.

XStart	0.07 V
XStop	0.27 V
HistogramValueNumber	273 (number of the row in an CSV file)
MeasValue	$(0.27 - 0.07) / 1000 * 273 + 0.07 = 0.1246 \text{ V}$

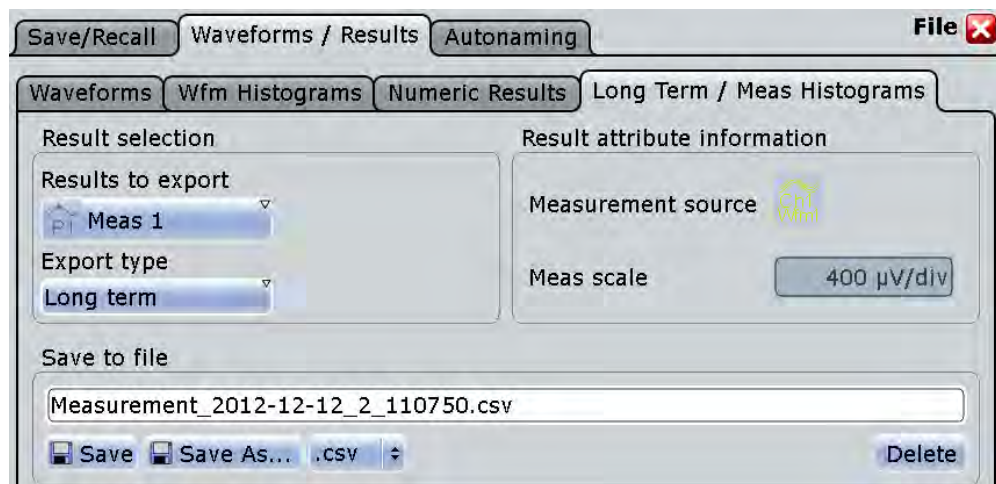

Results to export

Selects the measurement to be exported.

Remote command:

[EXPort:MEASurement:SElect](#) on page 928

Export type

You can export the result data of the long term measurement, or the measurement histogram. To export the data, the required type must be enabled in "Measurements > Long Term/Track": "Long term Enable" or "Histogram Enable".

Remote command:

[EXPort:MEASurement:TYPE](#) on page 928

Incidence

Sets the mode of exported histogram data: relative or absolute count of values. If relative values are exported, the sum of all values is 1, and the count of each value is set in relation to the sum.

Remote command:

[EXPort:HISTogram:INCidence](#) on page 927

Measurement source, Meas scale

Show the measurement settings source and scale for information.

Save to file

Enter the file name to save the measurement data to. Double-tap the file name to open the file selection dialog box.

By default, the file name has the prefix "Measurement_". You can define a pattern for automatic naming in the "Autonaming" tab. the default directory is:

Windows XP:

C:\Documents and Settings\All Users\Documents\Rohde-Schwarz\RTO\Measurements.

Windows 7:

C:\Users\Public\Documents\Rohde-Schwarz\RTO\Measurements

"Save"	Saves the measurement data in the selected file.
"Save As..."	Opens the file selection dialog box and saves the measurement data to the selected file. See also chapter 11.2.4, "File Selection Dialog" , on page 386
".bin/.xml/.csv"	Selects the file format.
Remote command:	
	EXPort:HISTogram:NAME on page 927
	EXPort:MEASurement:SAVE on page 929
	EXPort:MEASurement:DATA? on page 929

11.2.3 Autonoming

In this tab you can define the pattern for automatic file name generation. This name is used as the default file name in the file selection dialog box when data is saved to a new file ("Save As").

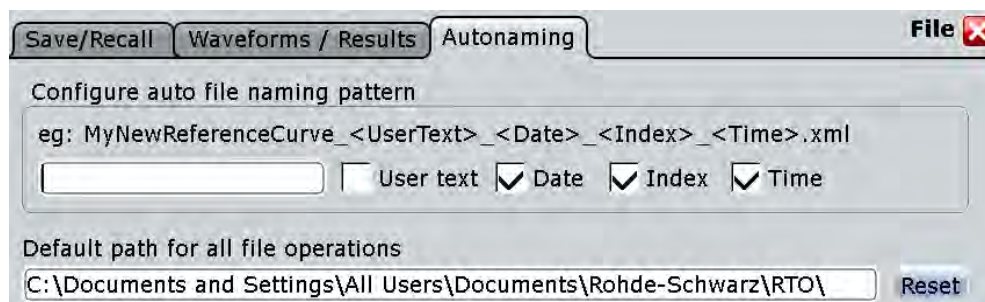

User text

User-defined text to be inserted after the prefix.

User text (enable)

If enabled, inserts the specified user text after the prefix.

Date

If enabled, inserts the current date.

Index

If enabled, inserts an index.

Time

If enabled, inserts the current time.

Default path for all file operations

Defines the default path displayed in the file selection dialog box for loading and storing operations.

Reset

Resets the default file path.

11.2.4 File Selection Dialog

The file selection dialog provides a file explorer from which you can select a file to load or to save data to.

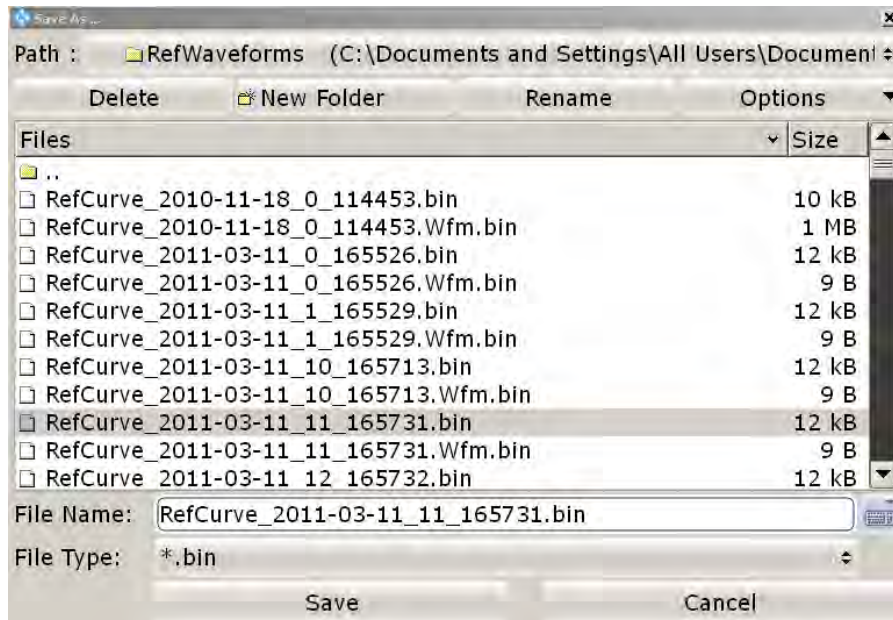

Path

Tap the path to change the current folder. The default folder is defined in ["Default path for all file operations"](#) on page 385.

You can save the data in a local folder on the instrument, to an external storage device (usually a USB flash drive), or to an folder on a connected network drive. The path list provides all available drives and folders.

Delete

Deletes the selected file

New Folder

Creates a new subfolder in the current folder.

Rename

Opens an online keyboard to enter a new name for the selected file or folder.

Options

Opens a menu with view and delete options.

- "Size" Shows the a column with the file sizes.
- "Last modified" Show a column with the date and time of the last modification of the file.
- "Multi-selection for delete" Enables multi-selection. Tap the files you want delete, and then tap the "Delete" button.

"Select all files for delete"

Selects all files in the current folder. Tap the "Delete" button to remove the files.

File Name

The file name to be loaded or stored to. Double-tap the file name to open the file selection dialog and select a different file name, or enter the file name directly using the online keyboard.

The default file name for new files is defined in the "Autonaming" tab, see [chapter 11.2.3, "Autonaming"](#), on page 385.

**Online keyboard**

Opens an online keyboard to enter the file name. Tap the ENTER key to close the keyboard.

File Type

The file extension of the file to be loaded or stored to.

Select

Selects the specified file for the open or save operation and closes the dialog box.

Cancel

Closes the dialog box without selecting a file.

11.3 Reference for PRINT Settings

The PRINT key provides functions for printing data to a printer or a file on the instrument.

The data to be printed is a screenshot of the graphic area, without any dialog boxes that may be open. The print image is created when you press the PRINT key or select "File" menu > "Print", and can be updated at any time.

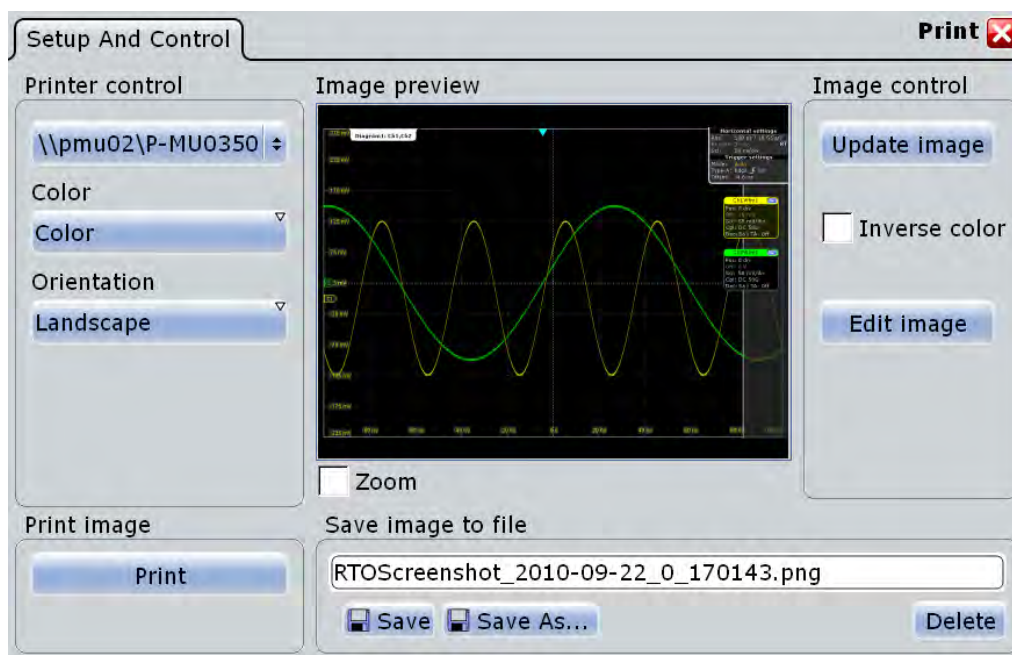

Printer.....	388
Color.....	389
Orientation.....	389
Image preview.....	389
L Zoom.....	389
Update image.....	389
Inverse color.....	389
Edit image.....	389
Print.....	389
Save image to file.....	390
L Save.....	390
L Save As.....	390
L Delete.....	390

Printer

Selects a configured printer. You can use a local printer or a network printer. The instrument firmware uses the Windows printer configuration, no additional printer setup is required. To make a printer available for R&S RTO, add and configure it in the Windows operating system:

Windows XP: "Printers and Faxes".

Windows 7: "Devices and Printers"

Depending on the printer driver, printing to a file is also possible. By default, the "RS Printer" drivers for JPG, PDF, PNG, and TIFF files are installed. To configure the name and storage location of the printed files, open the Windows printer configuration window (see above) and select "File > Printing Preferences > Save" for the required driver.

Remote command:

`SYSTem:COMMunicate:PRINter:SElect<1..2>` on page 933

Color

Defines the color mode for printing.

"Black and white" Black and white output

"Color" Color output

Remote command:

[HCOPY:DEVICE<m>:COLor](#) on page 931

Orientation

Toggles the page orientation between "Landscape" and "Portrait."

Remote command:

[HCOPY:PAGE:ORientation<1..2>](#) on page 931

Image preview

Shows a preview of the print image. The image is created when the PRINT key, or "File" menu > "Print", or "Update image" is selected.

Zoom ← Image preview

Enlarges the preview display and adds scrollbars to zoom into specific areas of the print image. Zooming does not affect the original display.

Update image

Updates the preview of the print image with the current display view, e.g. after changes to the settings have been made or an additional channel has been activated.

Inverse color

Inverts the colors of the output, i.e. a dark waveform is printed on a white background.

Remote command:

[HCOPY:DEVICE<m>:INVerse](#) on page 931

Edit image

Opens a temporary file with the current print image in a graphic editor. There you can edit the image. Save and print the image, or use "Save as" to set the file name and storage location. The changes are not shown in the preview.

Print

Prints the current print image together with saved editing changes on the selected [Printer](#).

If the printer is configured to print to a file, "Print" is an alternative of "Save image to file".

Remote command:

[HCOPY:DESTination<1..2>](#) on page 930

[HCOPY:IMMediate<m>\[:DUM\]](#) on page 932

[HCOPY:IMMediate<m>:NEXT](#) on page 932

Save image to file

Defines the file name if the print image is saved. By default, the file name has the prefix "RTOScreenshot_".

Double-tap the file name to open the file selection dialog box.

Remote command:

[HCOpy:DEvIce<m>:LANGUage](#) on page 931

[HCOpy:DESTination<1..2>](#) on page 930

[MMEMorY:NAME](#) on page 930

Save ← Save image to file

Saves the current print image to the specified file name.

Remote command:

[HCOpy:IMMediate<m>\[:DUM\]](#) on page 932

[HCOpy:IMMediate<m>:NEXT](#) on page 932

Save As... ← Save image to file

Opens the file selection dialog box and saves the current print image to the selected file name.

Delete ← Save image to file

Opens the file selection dialog box and deletes the selected file.

Remote command:

[MMEMorY:DELeTe](#) on page 917

12 General Instrument Setup

Some basic instrument settings concerning the user interface and general system are configurable and may need to be adapted to your specific requirements. Furthermore, the input channels may need to be aligned.

12.1 Setting Up the Instrument

The following setup procedures are described in other chapters of the documentation:

- [chapter 13.2, "Updating the Firmware"](#), on page 407
- [chapter 13.3, "Installing Options"](#), on page 409
- [chapter 13.4.2, "LXI Configuration"](#), on page 413
- [chapter 2.1.4, "Connecting External Devices"](#), on page 22

Basic setup procedures for the instrument are the following:

- [Performing a Self-alignment](#).....391
- [Aligning the Touchscreen](#).....392
- [Adjusting Passive Probes](#)..... 392

12.1.1 Performing a Self-alignment

The self-alignment aligns the data from several input channels vertically and horizontally in order to synchronize the time bases, amplitudes and positions. The self-alignment process includes a basic hardware check.

Recommendation on performing the self-alignment:

- when putting the instrument into operation for the first time
- after a firmware update
- once a week
- when major temperature changes occur ($> 5^{\circ}$)

NOTICE

Warm-up and prepare the instrument

Make sure that the instrument has been running and warming up before you start the self-alignment. The minimum warm-up time is indicated in the data sheet.

Remove the probes from the input connectors.

1. From the "File" menu, select "Selfalignment".
2. On the "Control" tab, tap "Start Alignment".

The alignment is performed, the process might take several minutes. A message box informs you about the running process, wait until this message box closes.

The overall pass/fail result is shown in the "Overall alignment state" field. The results of the individual alignment steps for each input channel are indicated in the "Results" tab. This information is mainly required if problems arise.

12.1.2 Aligning the Touchscreen

When the device is delivered, the touchscreen is initially calibrated. However, to ensure that the touchscreen responds to the finger contact correctly, a touchscreen alignment is required.

Alignment of the touchscreen is useful:

- At first use
 - If the position of the instrument has been changed and you cannot look straight on the screen
 - If another person operates the instrument
 - If you notice that touching a specific point on the screen does not achieve the correct response
1. Press the SETUP key.
 2. Select the "Screen" tab.
 3. Tap "Touchscreen Calibration".
A blinking cross appears in the lower left corner of the screen.
 4. Touch and hold the blinking cross until it stops blinking.
Repeat this action for the crosses in the other corners.
 5. Tap the RTO button in the task bar to display the instrument's user interface.

12.1.3 Adjusting Passive Probes

R&S RT-ZP10 passive probes are already pre-compensated to the R&S RTO front-end characteristics, and a compensation procedure is not required.

If you use other passive probes, the R&S RTO allows you to compensate it when it is connected to the instrument the first time. Compensation matches the probe cable capacitance to the oscilloscope input capacitance to assure good amplitude accuracy from DC to upper bandwidth limit frequencies. A poorly compensated probe reduces the performance of the probe-oscilloscope system and introduces measurement errors resulting in distorted waveforms and inaccurate results.

Two connector pins are located on the front panel. The right pin is on ground level. The left pin supplies a square wave signal with 1 kHz for low frequency probe compensation.

1. Connect the BNC connector of the probe to input CH1.
2. Connect the probe's ground connector to the right compensation pin, and the tip with the left pin.

3. Press AUTOSSET.
A square wave appears on the display.
4. Adjust the compensation trimmer of the probe to optimum square wave response.
For details, refer to the documentation of your probe.

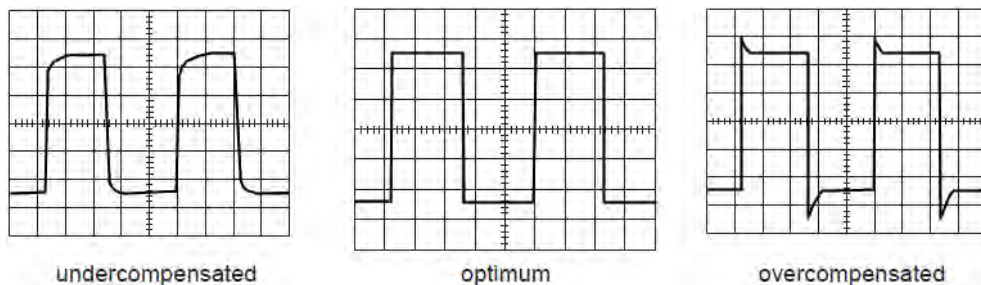

12.2 Reference for General Instrument Settings

The SETUP key provides functions for basic instrument settings.

"Self-alignment" is available from the "File" menu.

- [Setup](#).....393
- [Front Panel Setup](#).....402
- [Self-alignment](#).....403

12.2.1 Setup

- [System](#).....393
- [Screen](#).....395
- [SW Options](#).....398
- [HW Options](#).....399
- [Remote Settings](#).....399
- [LXI](#).....401

12.2.1.1 System

The settings on this tab are related to the basic instrument and system configuration.

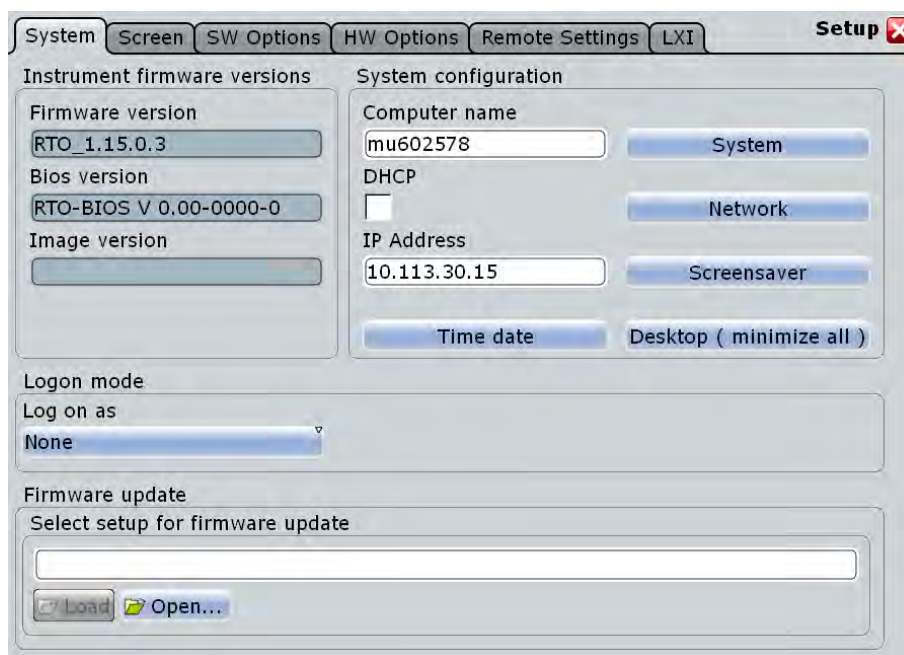

Firmware version

Indicates the firmware version currently installed on the instrument.

Remote command:

[DIAGnostic:SERVice:FWVersion?](#) on page 935

Bios version

Indicates the bios version currently installed on the instrument.

Image version

Indicates the image version currently installed on the instrument.

Desktop (minimize all)

Minimizes all displayed application windows on the instrument, so that the desktop becomes visible on the screen to access the Windows functionality.

This function is also available from the "File" menu.

Computer name, IP Address, DHCP

Indicates the currently defined computer name, the defined IP address and DHCP address enabling. These values are required to configure the instrument for work in a network.

NOTICE! Risk of network problems. All parameters can be edited here; however, beware that changing the computer name has major effects in a network. For details, see [chapter 13.4.1, "Setting Up a Network \(LAN\) Connection"](#), on page 410.

Remote command:

[DIAGnostic:SERVice:COMPutername](#) on page 935

System

Opens the standard Windows "System Properties" dialog box to configure system settings.

Network

Opens the standard Windows "Network Connections" dialog box to configure a network.

Screensaver

Opens the standard Windows "Display Properties" dialog box to configure a screensaver.

Time, date

Opens the standard Windows "Date and Time Properties" dialog box to set the correct date and time.

Note: Usually date and time are set correctly. To adjust your regional time, select the correct time zone rather than changing the time.

Remote command:

[SYSTem: DATE](#) on page 934

[SYSTem: TIME?](#) on page 935

Log on as

Sets the user that is automatically logged on during the startup process of the instrument. The change of this setting takes effect at the next instrument startup

"User autologon"	Auto-logout as standard user with limited access. Enter the "User name" and "Password" of the user who will log on at the next instrument startup.
"Admin autologon"	Auto-logout with unrestricted access to the instrument and network. The setting is only available for administrators. Enter the administrator "Password" to enable the auto-logout.
"None"	No auto-logout, user name and password are requested at instrument startup.

Select Setup for firmware update

Performs the firmware update.

See also: [chapter 13.2, "Updating the Firmware "](#), on page 407.

Load ← Select Setup for firmware update

Loads the specified file.

Open ← Select Setup for firmware update

Opens a file selection dialog box and loads the selected file (Setup_*.exe).

12.2.1.2 Screen

The settings on this tab are related to the screen display.

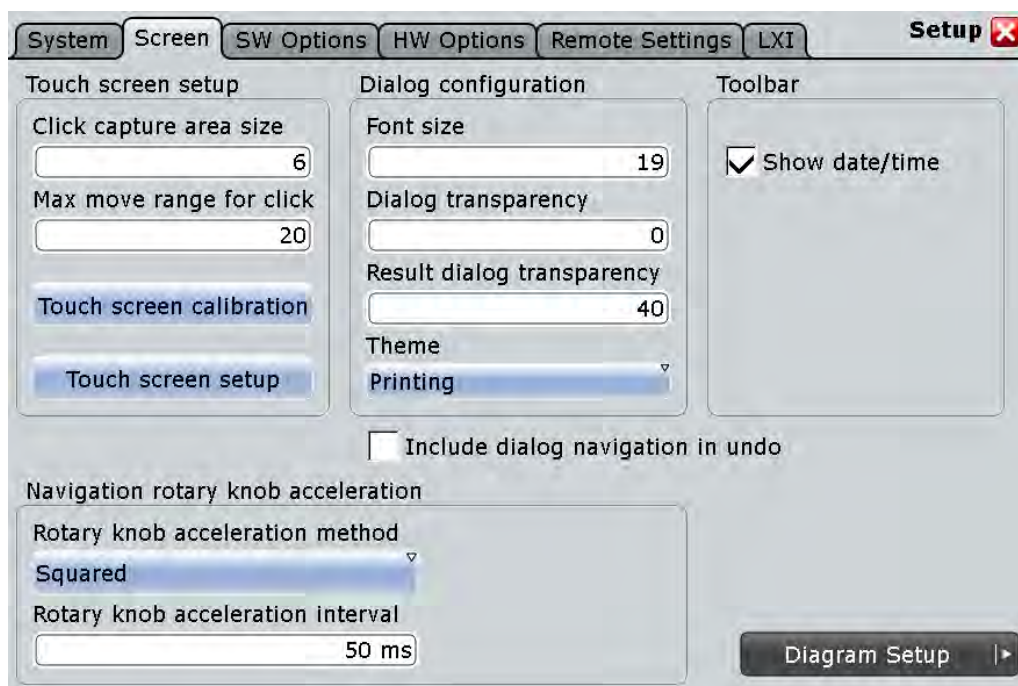

Click capture area size

Defines the number of pixels around each element (e.g. button, icon, data point) that create a capture area. If you tap your finger or click the mouse pointer within this capture area, this element is considered to be selected. If you tap or click outside this area, a different or no element is selected.

The larger the area, the easier is it to select an element. However, when selecting data points, for example, a large frame does not allow you to select precisely.

Max move range for click

Defines the maximum number of pixels around an element (e.g. data point) within which your pointing device must stay in order to "click" the element. When you tap your finger or click the mouse pointer on a specific element and move your finger or the mouse outside this range, it is considered to be a "moving" or "dragging") operation.

Touchscreen calibration

Opens the touch screen calibration application, see "Setting Up the Instrument" in the Quick Start Guide.

Touchscreen setup

Opens the touch screen configuration application for advanced touch screen setup and more sophisticated calibration.

Font size

Defines the font size of the text in dialog boxes.

Dialog transparency

Defines the transparency of the dialog box background. For high transparency values, you can see the waveform display in the background, and possibly check the effect of the changed setting. For lower transparency values, readability in the dialog box improves.

Result Dialog transparency

Defines the transparency of the measurement result boxes in the same way as [Dialog transparency](#).

Theme

Defines the color scheme and contrast of the dialog boxes. Different themes are provided to optimize the display for the most frequent operating situations.

"Default"	The default setting for standard operation according to user preferences
"Contrast"	Special setting for optimized contrast when using high transparency values for the dialog box background; dialog text is white, the background is dark-colored
"Printing"	Special setting for optimized printing; dialog text is black, background is light-colored

Include dialog navigation in undo

If enabled, navigation steps in dialogs are included and displayed when the undo function is used. Thus, you can see the changes to settings in dialogs as they are undone step by step.

If disabled, changes are also undone; however, the dialog is not displayed and you do not see which settings are restored.

Show date/time

Displays the current date and time on the toolbar.

Rotary knob acceleration method

Selects a method to accelerate the movement of the element on the screen compared to the actual movement of the rotary knob. Acceleration is useful if you need to move from one end of the screen to the other, for example. Without acceleration, you might have to turn the knob quite a while. On the other hand, acceleration can make precise selection difficult, since a small movement of the knob causes a relatively large movement on the screen.

"None"	No acceleration method used.
"Squared"	Moderate acceleration method used.
"Exponential"	Strong acceleration method used.

Rotary knob acceleration interval

Defines the delay time during which the movement of the rotary knob is analyzed before acceleration is applied. For short intervals, acceleration sets in quickly, but is not as effective. For long intervals, acceleration is more effective, however the delay time before a reaction occurs is longer. Furthermore, when you turn the knob slowly during finetuning, subsequent movements that occur during the same interval are accelerated, making precise selection difficult.

12.2.1.3 SW Options

This tab provides information on installed software options and functions to install new options via license keys.

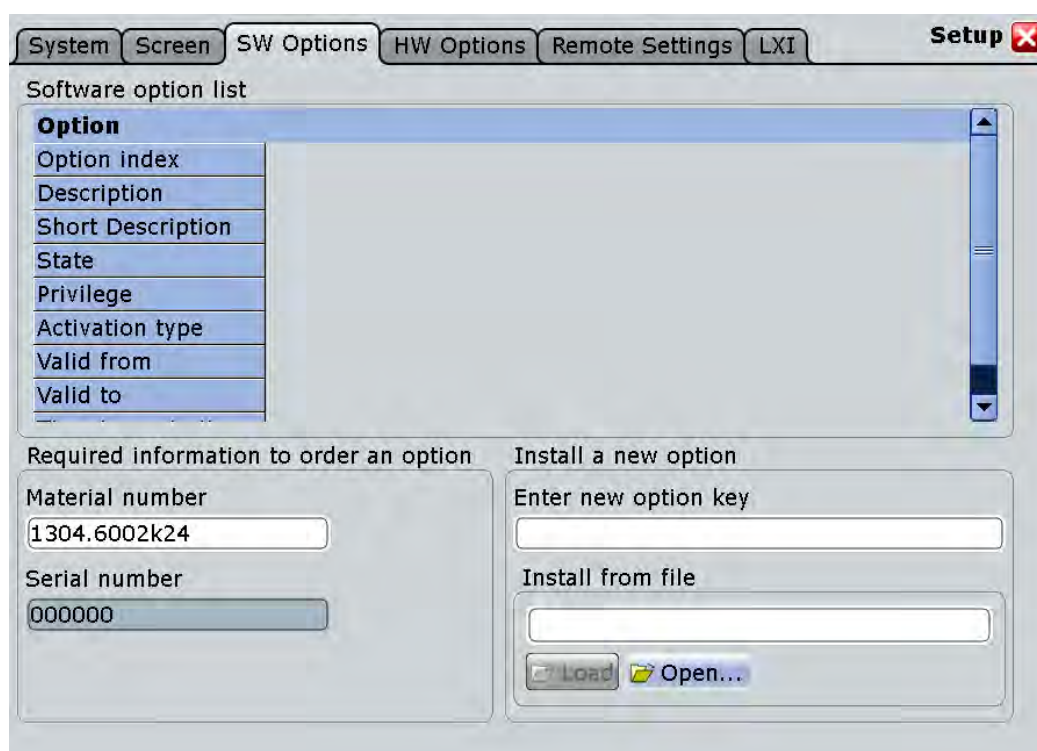

The "State" of the option indicates whether the installed option is an official or merely a beta-release version. Beta-release versions must be activated explicitly in the "Mode" dialog box (see [chapter 13.3.1, "Options in Beta State"](#), on page 410).

Option list

Indicates the installed options. The information provided in the "Option list" is for administration and troubleshooting purposes only. Should you require support for the option, provide this information to the service representative.

Material number, Serial number

Indicates the material number and serial number of your instrument. These numbers are required to order a new option.

Remote command:

[DIAGnostic:SERVice:PARTnumber](#) on page 936

[DIAGnostic:SERVice:SERialnumber?](#) on page 936

Enter new option key

For each option you order an option key is provided. Enter the option key here to activate the option.

Install from file

Alternatively to entering the option key manually, it can be read from a special option file provided with the option.

Load ← Install from file

Loads the specified file.

Open ← Install from file

Opens a file selection dialog box and loads the selected file.

12.2.1.4 HW Options

This tab provides information on the availability of hardware options.

12.2.1.5 Remote Settings

The settings on this tab are required for remote control of the instrument via a connected computer, see [chapter 21.1, "Basics"](#), on page 634.

Address

Indicates the GPIB address of the instrument if an optional GPIB bus card is installed.

The address can be edited here; however, beware that changing the address has major effects on the communication to the remote computer. For details see [chapter 21.1, "Basics"](#), on page 634.

Terminator

Specifies which symbol is used as a terminator in GPIB communication.

Transfer data format

Selects the data format that is used for transmission of waveform data from the instrument to the controlling computer.

Waveform data can be retrieved using the following commands:

- `CHANnel<m>[:WAVeform<n>]:DATA[:VALues]?`
- `CALCulate:MATH<m>:DATA[:VALues]?`
- `REFCurve<m>:DATA[:VALues]?`
- `DIGital<m>:DATA[:VALues]?`

The content of the data stream can be defined with `FILE > "Save/Recall > Waveforms > Interleaved X/Y"` (or `EXPort:WAVeform:INCXvalues`).

"Ascii" Data values are returned in ASCII format as a list of comma separated values in floating point format.

"FLOAT" Binary format. The data is stored as binary data (Definite Length Block Data according to IEEE 488.2).

"INT8" Signed integer data with length 8 bit.
For details on the formats, refer to the description of the remote command.

Remote command:

[FORMat\[:DATA\]](#) on page 673

Bit pattern format

Sets the format for all bit pattern queries.

Remote command:

[FORMat:BPATtern](#) on page 674

SCPI emulation mode

If option R&S RTO-K301 is installed, you can define the remote control behavior of the instrument.

"Tektronix DPO7000 / TDS540" Emulated remote commands of these Tektronix oscilloscopes are used.

"Native" By default, remote commands of R&S RTO are used.

Remote command:

[SYSTem:LANGuage](#) on page 675

SCPI emulation mode settings

"IDN response" and "OPT response" define the responses to commands `IDN*?` and `OPT*?` which are expected by the remote control scripts. Instead of the actual RTO identification and options, these specified strings are returned. Use the "Description" field to add a comment to the response settings.

The settings are only relevant if the SCPI emulation mode is set to Tektronix emulation (requires option R&S RTO-K301).

12.2.1.6 LXI

This tab provides settings for LXI, which allows you to connect your R&S RTO to other devices in a network. For details, see [chapter 13.4.2, "LXI Configuration"](#), on page 413.

LXI info	Value
Current version	1.3
LXI class	C
Computer name	MU609754
MAC address	00:1E:C9:37:0E:A5
IP address	10.113.10.49
Auto MDIX	Yes

Description

Instrument description of the R&S RTO.

Password

Password for LAN configuration. The default password is *LxiWebIfc*.

LAN Reset

Resets the LAN configuration to its default settings.

LXI Info

Displays the current LXI information from the R&S RTO.

"Current version"

Current LXI version

"LXI Class"

LXI device class

"Computer name"

Name of the R&S RTO as defined in the operating system

"MAC address"

Media Access Control address (MAC address), a unique identifier for the network card in the R&S RTO

"IP address"

IP address of the R&S RTO as defined in the operating system.

"Auto MDIX"

Enables the use of the built-in Auto-MDI(X) Ethernet functionality.

Reload Info

Reloads LXI configuration

12.2.2 Front Panel Setup

Front Panel settings adjust the luminosity of keys and screen.

LCD Intensity

Changes the background luminosity of the touch screen.

LED Intensity

Defines the luminosity of illuminated front panel keys and rotary knobs.

12.2.3 Self-alignment

When data from several input channels is displayed at the same time, it may be necessary to align the data vertically or horizontally in order to synchronize the time bases or amplitudes and positions. This is the case, for example, when strong temperature changes occur ($> 5^\circ$).

12.2.3.1 Control

Access: "File" menu > "Selfalignment"

**Start Alignment**

Starts the self-alignment procedure for all channels.

Remote command:

*CAL? on page 669

Date / Time / Overall alignment state

Show the date and the summary result of the self-alignment process: Passed or Failed. Detailed results are provided on the "Results" tab.

12.2.3.2 Results

For each channel, the results of the individual alignment steps are shown for all technical channel component. In case you require support, you may be asked to provide this information.



The screenshot shows a software window titled "Selfalignment" with a close button (red X) in the top right corner. The window has two tabs: "Control" and "Results", with "Results" currently selected. On the left side, there is a vertical list of channel icons labeled Ch1, Ch2, Ch3, and Ch4. The main area of the window contains a table with two columns: "Self alignment step" and "Alignment step results". The table lists 12 alignment steps, all of which have a result of "Ok".

Self alignment step	Alignment step results
THA offset	Ok
THA gain	Ok
Spc	Ok
Deskew	Ok
VarGain 50	Ok
FixGain 50	Ok
Offset 50	Ok
BufVarGain 1M	Ok
BufVarGain20dB1M	Ok
FixGain 1M	Ok
Offset 1M	Ok

13 Software and Network Operation

13.1 Operating System

The R&S RTO has a Windows operating system - Windows Embedded Standard 7 64 bit or Windows XP embedded.

The operating system has been configured according to the instrument's features and needs. To ensure that the instrument software functions properly, certain rules must be adhered to when using the operating system.

NOTICE

Risk of causing instrument unusability

The instrument is equipped with a Windows operating system. Additional software can therefore be installed on the instrument. The use and installation of additional software may impair instrument function. Thus, run only programs that Rohde & Schwarz has tested for compatibility with the instrument software.

The drivers and programs used on the instrument under Windows have been adapted to the instrument. Existing instrument software must always be modified using only update software released by Rohde & Schwarz.

Changes in the system setup are only required if the network configuration does not comply with the default settings (see [chapter 13.4.1.1, "Connecting the Instrument to the Network"](#), on page 411).

13.1.1 Virus Protection

Users must take appropriate steps to protect their instruments from infection. Beside the use of strong firewall settings and regularly scanning any removable storage device used with a Rohde & Schwarz instrument, it is also recommended that anti-virus software be installed on the instrument. While Rohde & Schwarz does NOT recommend running anti-virus software in the background ("on-access" mode) on Windows-based instruments, due to potentially degrading instrument performance, it does recommend running it during non-critical hours.

For details and recommendations, see the Rohde & Schwarz White Paper "Malware Protection" available at <http://www.rohde-schwarz.com/appnote/1EF73>.

13.1.2 Service Packs and Updates

Microsoft regularly creates security updates and other patches to protect Windows-based operating systems. These are released through the Microsoft Update website

and associated update server. Instruments using Windows, especially those that connect to a network, should be updated regularly.

For more details and information on configuring automatic updates see the R&S White Paper "Malware Protection" (available at <http://www.rohde-schwarz.com/appnote/1EF73>).

Changes in the system setup are only required when peripherals like keyboard or a printer are installed or if the network configuration does not comply with the default settings (see [chapter 13.4.1.1, "Connecting the Instrument to the Network"](#), on page 411). After the R&S RTO is started, the operating system boots and the instrument firmware is started automatically.

13.1.3 Logon

Windows requires that users identify themselves by entering a user name and password in a logon window. You can set up two types of user accounts, either an administrator account with unrestricted access to the computer/domain or a standard user account with limited access.

If the instrument is connected to the network, you are automatically logged on to the network at the same time you log on to the operating system. As a prerequisite, the user name and the password must be identical under Windows and on the network. The instrument provides an auto-logon function that can be configured for user and administrator access. The configuration requires the user name and password. All users except for the administrator are treated as standard user with limited access. See also: "[Log on as](#)" on page 395

By default, the user name for the administrator account is "instrument", and the user name for the standard user account is "NormalUser". In both cases the initial password is "894129". You can change the password for the standard user in the Windows configuration : "Start" menu > "Settings > Control Panel > User Accounts". Some administrative tasks require administrator rights, e.g. the configuration of a LAN network.

To configure the auto-logon for administrator

Starting situation: the auto-logon is configured for a standard user.

1. Press the SETUP key and select the "System" tab.
2. Set "Logon as" to "None".
3. Restart the instrument and log on as administrator.
4. Set the "Logon as" to "Admin autologon" and enter the administrator's password.

13.1.4 Accessing Windows functionality

All required Windows settings can be changed using the touchscreen and the on-screen keyboard that is part of the Windows system. However, modification is easier if you connect a mouse and/or keyboard to the instrument.

To access Windows

- ▶ On the "File" menu, select "Minimize application".

The application is minimized to the task bar and the "Start" menu becomes available.

To access Windows using an external keyboard

1. To open the "Start" menu, press the Windows key or the CTRL + ESC key combination on your keyboard.
2. To access the desktop, press the Windows key + D on your keyboard.

To access Windows settings directly from the firmware

Important Windows settings can be accessed directly from the R&S RTO interface.

1. Press the SETUP key and tap the "System" tab.
2. Select one of the settings buttons to access the corresponding Windows dialog box.

Once you have opened a Windows dialog box, the task bar and the "Start" menu are also available.

13.2 Updating the Firmware

The firmware on your R&S RTO may need to be updated in order to enable additional new features or if reasons for improvement come up. Ask your sales representative or check the www.scope-of-the-art.com/product/rto.html R&S RTO website for availability of firmware updates. The "Firmware" page provides the firmware installation file and the Release Notes.



Before updating the firmware on your instrument, read the Release Notes. The document informs about new and modified functions, known problems, and provides a detailed installation procedure that covers also specific installation scenarios.

1. Download the setup file `Setup_Rtx_x.xx.x.x.exe` from the www.scope-of-the-art.com/product/rto.html website and store it on a USB flash device, on a server network drive that can be accessed by the instrument, or directly on the instrument using Remote Desktop and a LAN connection.
2. Switch on the instrument and wait until the firmware is running.
3. **NOTICE!** Stop acquisition. The firmware update must not be performed during running acquisition.
If an acquisition is running, stop it by pressing RUN CONT or RUN N× SINGLE.
4. Insert the flash drive, or connect the instrument to the LAN.

5. Press the SETUP key, or tap "Setup" on the "File" menu.
6. Select the "System" tab.

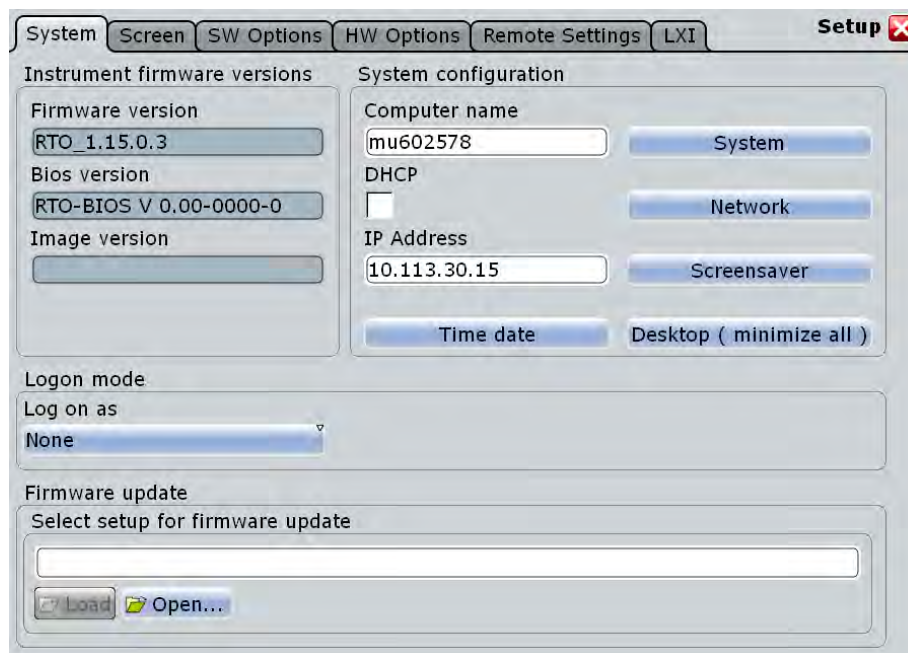

7. Tap "Open" under "Firmware update" on the bottom of the dialog box, and select the Setup* . exe file.
8. Change the path to the drive and directory which you prepared (USB flash device, remote PC directory or directory on a server), and tap "Select".
9. Tap "Next" in the installation dialog box and select the firmware packages. By default, all packages are installed.
10. Tap "Install" to start the update.
11. After the firmware update, the R&S RTO reboots automatically.
12. Depending on the previous firmware version, a reconfiguration of the hardware might be required during the first start of the firmware. The reconfiguration starts automatically, and a message box informs you about the process. Once the reconfiguration has finished, the instrument automatically reboots again.

Note: Do not switch off the instrument during the reconfiguration process!
13. The firmware update is complete. It is recommended that you perform a self-alignment after the update ("File > Selfalignment"). The self-alignment procedure is described in the "Getting Started" manual, chapter "Setting Up the Instrument". It may take several minutes.

13.3 Installing Options

Options are part of the instrument firmware. No additional installation is required. To activate an additional option, you need a license key. Consult your sales representative and provide the material number and serial number of your instrument to get a license key. The license key is provided in written form or in a file.

1. Press the SETUP key and select the "SW options" tab.

2. If you received a key in written form, enter the key in the "Enter new option key" field.
If you received a key in digital form as a file, Tap "Open" to open the file selection dialog box, navigate to the directory that contains the file, and select the option key file.
3. If you want to activate several options, repeat step 3 for each option.
4. Restart the instrument or restart the firmware.



The information provided in the "Option list" is for administration and troubleshooting purposes only. If you require support for the option, provide this information to the service representative.

See also: [chapter 12.2.1.3, "SW Options"](#), on page 398

13.3.1 Options in Beta State

Options may be released in beta state. These options require a license key and an additional activation.

To enable these options, press the MODE key, select the "Operation Mode" tab and activate "Enable options in beta state".

The activation is effective immediately until the next shut-down of the firmware.

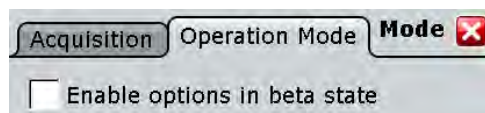

13.4 Operation in a Network

A LAN connection is the prerequisite for all network operations. The LAN connection settings can be configured directly in the Windows operating system, or with LXI (LAN eXtension for Instruments).

Remote operation (Windows 7)

The remote desktop connection of Windows Embedded Standard 7 can be used for instrument control and file transfer. Even on computers with non-Windows operating systems a remote desktop connection is possible using RDP-applications.

Remote operation (Windows XP)

The Remote Desktop Connection of Windows XP is not supported for instrument control. Remote Desktop can only be used for file transfer from and to the instrument.

Remote monitoring and control of the instrument from a connected computer is possible with a standard web browser and the common cross-platform technology Virtual Network Computing (VNC). You have to install the VNC server on the R&S RTO. Installation and configuration is described in the Application Note "Remote Monitoring and Control of the R&S RTO with a Web Browser", available on the Rohde & Schwarz Internet.

13.4.1 Setting Up a Network (LAN) Connection

The R&S RTO is equipped with a network interface and can be connected to an Ethernet LAN (local area network). Provided the appropriate rights have been assigned by the network administrator and the Windows firewall configuration is adapted accordingly, the interface can be used, for example:

- To transfer data between a controller and the tester, e.g. in order to run a remote control program. See chapter "Remote Control"
- To access or control the measurement from a remote computer using the "Remote Desktop" application (or a similar tool)

- To connect external network devices (e.g. printers)
- To transfer data from a remote computer and back, e.g. using network folders

This section describes how to configure the LAN interface. It includes the following topics:

- [chapter 13.4.1.1, "Connecting the Instrument to the Network"](#), on page 411
- [chapter 13.4.1.2, "Assigning the IP Address"](#), on page 412



LXI

The R&S RTO complies with LXI Class C. LXI gives you direct access to the LAN settings described below.

13.4.1.1 Connecting the Instrument to the Network

There are two methods to establish a LAN connection to the instrument:

- A non-dedicated network (Ethernet) connection from the instrument to an existing network made with an ordinary RJ-45 network cable. The instrument is assigned an IP address and can coexist with a computer and with other hosts on the same network.
- A dedicated network connection (Point-to-point connection) between the instrument and a single computer made with a (crossover) RJ-45 network cable. The computer must be equipped with a network adapter and is directly connected to the instrument. The use of hubs, switches, or gateways is not required, however, data transfer is still performed using the TCP/IP protocol. An IP address has to be assigned to the instrument and the computer, see [chapter 13.4.1.2, "Assigning the IP Address"](#), on page 412.

NOTICE

Risk of network failure

Before connecting the instrument to the network or configuring the network, consult your network administrator. Errors may affect the entire network.

- ▶ To establish a non-dedicated network connection, connect a commercial RJ-45 cable to one of the LAN ports.
To establish a dedicated connection, connect a (crossover) RJ-45 cable between the instrument and a single PC.

If the instrument is connected to the LAN, Windows automatically detects the network connection and activates the required drivers.

The network card can be operated with a 10/100/1000 Mbps Ethernet IEEE 802.3u interface.

13.4.1.2 Assigning the IP Address

Depending on the network capacities, the TCP/IP address information for the instrument can be obtained in different ways.

- If the network supports dynamic TCP/IP configuration using the Dynamic Host Configuration Protocol (DHCP), all address information can be assigned automatically.
- If the network does not support DHCP, or if the instrument is set to use alternate TCP/IP configuration, the addresses must be set manually.

By default, the instrument is configured to use dynamic TCP/IP configuration and obtain all address information automatically. This means that it is safe to establish a physical connection to the LAN without any previous instrument configuration.

NOTICE

Risk of network errors

Connection errors can affect the entire network. If your network does not support DHCP, or if you choose to disable dynamic TCP/IP configuration, you must assign valid address information before connecting the instrument to the LAN. Contact your network administrator to obtain a valid IP address.

Assigning the IP address on the instrument

1. Press the SETUP key and select the "System" tab.
2. Tap "Network".
3. Touch and hold (or right-click) "Local Area Connection" and select "Properties".
4. Windows XP:
On the "General" tab, select "Internet Protocol (TCP/IP)" and then select "Properties".
Windows 7:
On the "Networking" tab, select "Internet Protocol Version 4 (TCP/IPv4)" and then select "Properties".
5. Select "Use the following IP address" and enter the address information as obtained from the network administrator.
6. If necessary, select "Use the following DNS server addresses" and enter your own DNS addresses.

13.4.1.3 Using computer names

Alternatively to the IP address, each PC or instrument connected in a LAN can be accessed via an unambiguous computer name. Each instrument is delivered with an assigned computer name, but this name can be changed.

To change the computer name

1. Press the SETUP key and select the "System" tab or "LXI" tab.
The current computer name is displayed and can be edited.
2. Alternatively, tap "System" on the "System" tab.
3. Select "Change", enter the new computer name and confirm the entry.

13.4.1.4 Changing the Windows Firewall Settings

A firewall protects an instrument by preventing unauthorized users from gaining access to it through a network. Rohde & Schwarz highly recommends the use of the firewall on your instrument. Rohde & Schwarz instruments are shipped with the Windows firewall enabled and preconfigured in such a way that all ports and connections for remote control are enabled. For more details on firewall configuration see the Rohde & Schwarz White Paper "Malware Protection" (available at http://www2.rohde-schwarz.com/file_13784/1EF73_0E.pdf) and the Windows Help system.

Note that changing firewall settings requires administrator rights.

13.4.2 LXI Configuration

LAN eXtensions for Instrumentation (LXI) is an instrumentation platform for measuring instruments and test systems that is based on standard Ethernet technology. LXI is intended to be the LAN-based successor to GPIB, combining the advantages of Ethernet with the simplicity and familiarity of GPIB.

13.4.2.1 LXI Classes and LXI Functionality

LXI-compliant instruments are divided into three classes, A, B and C, with the functionality of the classes hierarchically based one upon the other:

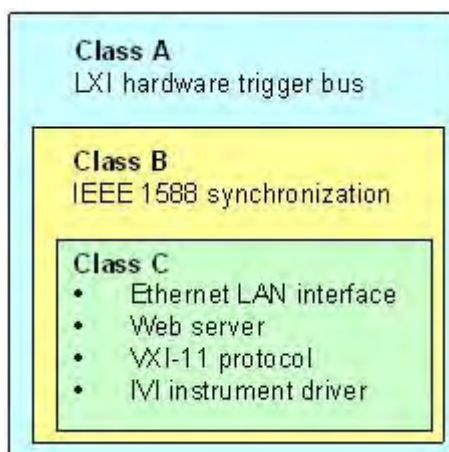

- **Class C** instruments are characterized by a common LAN implementation, including an ICMP ping responder for diagnostics. The instruments can be configured via a web browser; a LAN Configuration Initialize (LCI) mechanism resets the LAN

configuration. The LXI Class C instruments shall also support automatic detection in a LAN via the VXI-11 discovery protocol and programming by means of IVI drivers.

- **Class B** adds IEEE 1588 Precision Time Protocol (PTP) and peer-to-peer communication to the base class. IEEE 1588 allows all instruments on the same network to automatically synchronize to the most accurate clock available and then provide time stamps or time-based synchronization signals to all instruments with exceptional accuracy.
- **Class A** instruments are additionally equipped with the eight-channel hardware trigger bus (LVDS interface) defined in the LXI standard.



For information about the LXI standard refer to the LXI website at <http://www.lxistandard.org>. See also the article at the Rohde&Schwarz website: <http://www2.rohde-schwarz.com/en/technologies/connectivity/LXI/information/>.

Instruments of classes A and B can generate and receive software triggers via LAN messages and communicate with each other without involving the controller.

The R&S RTO complies with LXI Class C. In addition to the general class C features described above, it provides the following LXI-related functionality:

- Integrated "LXI Configuration" dialog box for LXI activation and reset of the LAN configuration (LAN Configuration Initialize, LCI).



Firmware update

After a firmware update, shut-down and re-start the instrument in order to enable the full LXI functionality.

13.4.2.2 LXI Configuration

The "LXI" tab of the "Setup" dialog box provides basic LXI functions and information for the R&S RTO.

The screenshot shows the LXI Setup interface with the following elements:

- Navigation tabs:** System, Screen, SW Options, HW Options, Remote Settings, LXI (selected), Setup (with a close icon).
- Description:** Rohde & Schwarz Oscilloscope / RTO / 000000
- Setup section:** Password field containing "LxiWebIfc". A "LAN Reset" button is located below the password field.
- Info section:** A table displaying LXI information and a "Reload info" button below it.

LXI info	Value
Current version	1.3
LXI class	C
Computer name	MU609754
MAC address	00:1E:C9:37:0E:A5
IP address	10.113.10.49
Auto MDIX	Yes

Default state of the network settings

"Reset" initiates the network configuration reset mechanism (LCI) for the instrument.

According to the LXI standard, an LCI must set the following parameters to a default state.

Parameter	Value
TCP/IP Mode	DHCP + Auto IP Address
Dynamic DNS	Enabled
ICMP Ping	Enabled
Password for LAN configuration	LxiWebIfc

The LAN settings are configured using the instrument's LXI Browser Interface.

13.4.2.3 LXI Browser Interface

The instrument's LXI browser interface works correctly with all W3C compliant browsers.

- Type the instrument's host name or IP address in the address field of the browser on your PC, e.g. "http://10.113.10.203".

The "Instrument Home Page" (welcome page) opens.

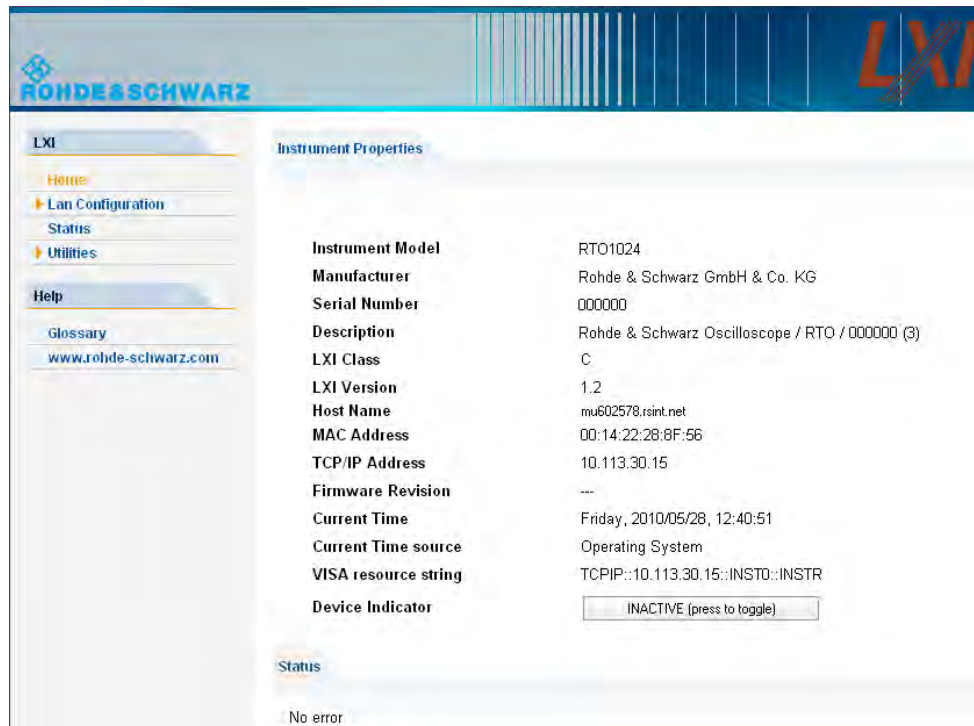

The instrument home page displays the device information required by the LXI standard including the VISA resource string in read-only format.



- ▶ Press the "Device Indicator" button to activate or deactivate the LXI status icon on the toolbar of the R&S RTO. A green LXI status symbol indicates that a LAN connection has been established; a red symbol indicates an error, for example, that no LAN cable is connected. While a device is connecting to the instrument, the LXI logo is blinking, and the "Host Name" is updated on the LXI home page. The "Device Indicator" setting is not password-protected.

The most important control elements in the navigation pane of the browser interface are the following :

- "LAN Configuration" opens the menu with configuration pages.
- "Status" displays information about the LXI status of the instrument.
- "Help > Glossary" opens a document with a glossary of terms related to the LXI standard.

13.4.2.4 LAN Configuration

The LAN configuration consists of three parts:

- "IP configuration" provides all mandatory LAN parameters.
- "Advanced LAN Configuration" provides LAN settings that are not declared mandatory by the LXI standard.
- "Ping Client" provides the ping utility to verify the connection between the instrument and other devices.

IP Configuration

The "LAN Configuration > IP configuration" web page displays all mandatory LAN parameters and allows their modification.

The screenshot shows the "LAN Parameters" configuration page. On the left is a navigation menu with "LXI" at the top, followed by "Home", "Lan Configuration" (with sub-items "IP Configuration", "Advanced Config", and "Ping Client"), "Status", "Utilities", "Help", "Glossary", and "www.rohde-schwarz.com". The main content area is titled "LAN Parameters" and contains the following fields:

- Hostname: mu602578.rsint.net
- Domain: rsint.net
- Description: Rohde & Schwarz WaveForm Analyzer / RTC
- TCP/IP Mode: Static IP Address (dropdown menu)
- IP Address: 10.113.30.15
- Subnet Mask: 255.255.0.0
- Default Gateway: 10.113.0.1
- DNS Server(s): 10.0.2.166, 10.0.23.159
- Dynamic DNS: Enabled, Disabled

At the bottom, there is a "Submit" button and a password field with the text "(Password required!)" next to it.

The "TCP/IP Mode" configuration field controls how the IP address for the instrument gets assigned (see also [chapter 13.4.1.2, "Assigning the IP Address"](#), on page 412). For the manual configuration mode, the static IP address, subnet mask, and default gateway are used to configure the LAN. The automatic configuration mode uses DHCP server or Dynamic Link Local Addressing (Automatic IP) to obtain the instrument IP address.



Changing the LAN configuration is password-protected. The password is *LxiWebIfc* (notice upper and lower case characters). This password cannot be changed in the current firmware version.

Advanced LAN Configuration

The screenshot shows the "Advanced LAN Configuration" page. On the left is the same navigation menu as in the previous screenshot. The main content area is titled "LAN Parameters" and contains the following fields:

- Negotiation: Auto Detect (dropdown menu)
- ICMP Ping: Enabled, Disabled
- VXI-11 Discovery: Disabled, Enabled
- mDNS and DNS-SD: Disabled, Enabled

At the bottom, there is a "Submit" button and a password field with the text "(Password required!)" next to it.

The "LAN Configuration > Advanced LAN Configuration" parameters are used as follows:

- The "Negotiation" configuration field provides different Ethernet speed and duplex mode settings. In general, the "Auto Detect" mode is sufficient.

- "ICMP Ping" must be enabled to use the ping utility.
- "VXI-11" is the protocol that is used to detect the instrument in the LAN. According to the standard, LXI devices must use VXI-11 to provide a detection mechanism; other additional detection mechanisms are permitted.
- mDNS and DNS-SD are two additional protocols: Multicast DNS and DNS Service Discovery. They are used for device communication in zero configuration networks working without DNS and DHCP

Ping Client

Ping is a utility that verifies the connection between the LXI-compliant instrument and another device. The ping command uses the ICMP echo request and echo reply packets to determine whether the LAN connection is functional. Ping is useful for diagnosing IP network or router failures. The ping utility is not password-protected.

To initiate a ping between the LXI-compliant instrument and a second connected device:

1. Enable "ICMP Ping" on the "Advanced LAN Configuration" page (enabled after an LCI).
2. On the "Ping Client" page, enter the IP address of the second device **without the ping command and without any further parameters** into the "Destination Address" field (e.g. *10.113.10.203*).
3. Click "Submit".

Ping Parameter

Destination Address

Result

```
Pinging 10.113.30.15 with 32 bytes of data:
Reply from 10.113.30.15: bytes=32 time<1ms TTL=128
Reply from 10.113.30.15: bytes=32 time<1ms TTL=128
Reply from 10.113.30.15: bytes=32 time<1ms TTL=128
Reply from 10.113.30.15: bytes=32 time<1ms TTL=128

Ping statistics for 10.113.30.15:
    Packets: Sent = 4, Received = 4, Lost = 0 (0%
loss),
```

14 Protocol Analysis (Base Functions and Options R&S RTO-K1 to K5)

With the R&S RTO and some additional options, you can analyze the following serial protocols:

- SPI (Serial Peripheral Interface) - decoding requires option R&S RTO-K1
- I²C (Inter-Integrated circuit bus) - decoding requires option R&S RTO-K1
- UART/RS232 (EIA-232 serial interface) - decoding requires option R&S RTO-K2
- CAN - decoding and triggering require option R&S RTO-K3
- LIN - decoding and triggering require option R&S RTO-K3
- FlexRay - decoding and triggering require option R&S RTO-K4
- Audio - decoding, triggering, track and trend analysis requires option R&S RTO-K5

Triggering on SPI, I²C and UART is available with the main R&S RTO without any options.

• Basics of Protocol Analysis	419
• I²C	426
• SPI Bus	439
• UART / RS232	448
• CAN (Option R&S RTO-K3)	457
• LIN (Option R&S RTO-K3)	467
• FlexRay (Option R&S RTO-K4)	476
• Audio Signals (Option R&S RTO-K5)	490

14.1 Basics of Protocol Analysis

Before you can analyze a serial signal, the bus has to be configured according to the protocol and specifics of the signal. The configuration contains:

- Assignment of the data and clock lines to the input channels
- Logical thresholds
- Protocol-specific settings

Serial data can be analyzed in two ways:

- **Triggering:** You can trigger on various events that are typical for the selected protocol type, for example, on start and stop of messages, on specific addresses, or on specified data patterns in the message.
Triggering on a trigger event sequence is not supported, and holdoff settings are not available.
For all serial protocols except for SPI, I²C and UART, triggering requires an option.
- **Protocol decoding:** The digitized signal data is displayed on the screen together with the decoded content of the messages in readable form, and the decoding results are listed in a table.
For all serial protocols, decoding requires an option.

14.1.1 Configuration - General Settings

For all protocols, configuration starts with the selection of the serial bus and the protocol. The "Trigger Setup" button leads directly to the trigger configuration.

Protocol-specific configuration settings are described in the protocol chapters:

- I²C: [chapter 14.2.2, "I²C Configuration"](#), on page 428
- SPI: [chapter 14.3.2, "SPI Configuration"](#), on page 440
- UART: [chapter 14.4.2, "UART Configuration"](#), on page 449
- LIN: [chapter 14.6.2, "LIN Configuration"](#), on page 468
- CAN: [chapter 14.5.1, "CAN Configuration"](#), on page 457
- FlexRay: [chapter 14.7.1, "FlexRay Configuration"](#), on page 477
- Audio: [chapter 14.8.2, "Audio Signal Configuration"](#), on page 492



Make sure that the tab of the correct serial bus is selected on the left side.

Protocol

Defines protocol type of the bus for bus configuration and trigger settings.

Remote command:

`BUS<m> : TYPE` on page 938

Decode

Enables the decoding of the selected bus. The signal icon appears on the signal bar.

This function is only available if at least one protocol option is installed. For triggering on I²C, SPI, and UART signals, the bus can be used as trigger source without any option, provided that the bus is configured correctly.

Remote command:

`BUS<m> [: STATE]` on page 938

14.1.2 Display

For all protocols, you can select to display the decoded signal as a table and to show the binary signal on the screen. Optionally, you can assign a label to the bus.



Bus label

Defines a label to be displayed with the bus.

Remote command:

[BUS<m>:LABel](#) on page 939

Show decode table

Opens a table with decoded data of the serial signal. The function requires the option for the analyzed protocol.

The decoding results are protocol-specific. They are described in the related chapters:

- I²C: [chapter 14.2.5, "I²C Decode Results \(Option R&S RTO-K1\)"](#), on page 436
- SPI: [chapter 14.3.4, "SPI Decode Results \(Option R&S RTO-K1\)"](#), on page 447
- UART: [chapter 14.4.4, "UART Decode Results \(Option R&S RTO-K2\)"](#), on page 454
- LIN: [chapter 14.6.5, "LIN Decode Results"](#), on page 475
- CAN: [chapter 14.5.4, "CAN Decode Results"](#), on page 465

Remote command:

[BUS<m>:RESult](#) on page 939

Show binary signals

For each configured line, the binary signal is displayed additionally to the decoded signal.

Show threshold lines

If selected, the threshold levels are displayed in the diagram.

Data format

Sets the data format for decoded data values in the "Decode results" box and on the display of the decoded signal.

Remote command:

[BUSFormat](#) on page 939

Binary bit order

Select MSB or LSB to define the data bit order in the display of the decoded signal. The setting is only available for the binary data format.

Binary bit group size

Sets the number of bits that forms a bit group in the display. The setting is only available for the binary data format.

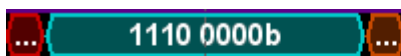

MSB first, bit group size = 4



LSB first, bit group size = 8

14.1.3 Label Lists

For all protocols using ID or address identification, it is possible to create label lists containing addresses or IDs, a symbolic name for each node (symbolic label), and some protocol-specific information. You can load label lists, and activate its usage for decoding. As a result, an additional "Label" column appears in the "Decode results" table, containing the symbolic label. The frame captions of the decoded signal show the symbolic label instead of the ID or address values so it is easy to identify the messages of the different bus nodes.

14.1.3.1 Content and Format of the PTT File

Label lists are stored as PTT (protocol translation table) files. The PTT file format is an extension of the CSV format (comma separated values). You can edit it with standard editors, for example, with MS Excel or a text editor.

The PTT file has three types of lines:

- Comment lines begin with a hash character #. A hash character at any other position in the line is treated like a standard character.
- Command lines begin with a commercial at character @. An @ character at any other position in the line is treated like a standard character.
- Standard lines are the lines that not qualify as comment or command lines. They build the core of the label list.

Command lines

Command lines define the version of the PTT file and the protocol name:

- @FILE_VERSION: must appear exactly once in the file

- **@PROTOCOL_NAME**: must appear at least once in the file. Thus, one file can contain several label lists for different protocols.

```
# --- Start of PTT file
@FILE_VERSION = 1.0
@PROTOCOL_NAME = i2c
[... Label list for I2C]
@PROTOCOL_NAME = can
[... Label list for CAN]
# --- End of PTT file
```

Standard lines

Standard lines define the contents of the label list. The rules for standard lines follow the csv convention, they are:

- Values are separated by commas
- Space characters following a delimiter are ignored
- Values with a special character (comma, newline, or double quote) must be enclosed in double quotes
- Text in double quotes must be escaped by double quote characters

Additionally, numeric values may be decimal integer (default) or hexadecimal integer (with prefix "0x")

```
# --- Start of PTT file
@FILE_VERSION = 1.0
@PROTOCOL_NAME = i2c
#   Following two lines are equal:
7,0x01,Temperature
7,0x01, Temperature
#   A comma must be enclosed in double quotes:
7,0x01,"Temperature, Pressure, and Volume"
#   A double quote must also be enclosed in double quotes:
7,0x7F,"Highspeed ""Master"" 01"
#   Following lines yield the same result:
7,0x11,Pressure
0x7,0x11,Pressure
0x7,17,Pressure
1,17,Pressure
```

Label lists are protocol-specific. Their contents are described in the corresponding protocol chapters:

- [chapter 14.2.4, "I²C Label List"](#), on page 435
- [chapter 14.5.3, "CAN Label List"](#), on page 463
- [chapter 14.6.4, "LIN Label List"](#), on page 473
- [chapter 14.7.3, "FlexRay Label List"](#), on page 485

14.1.3.2 Label List - General Settings

In the "Label List" tab, you can load, read and activate label list files.

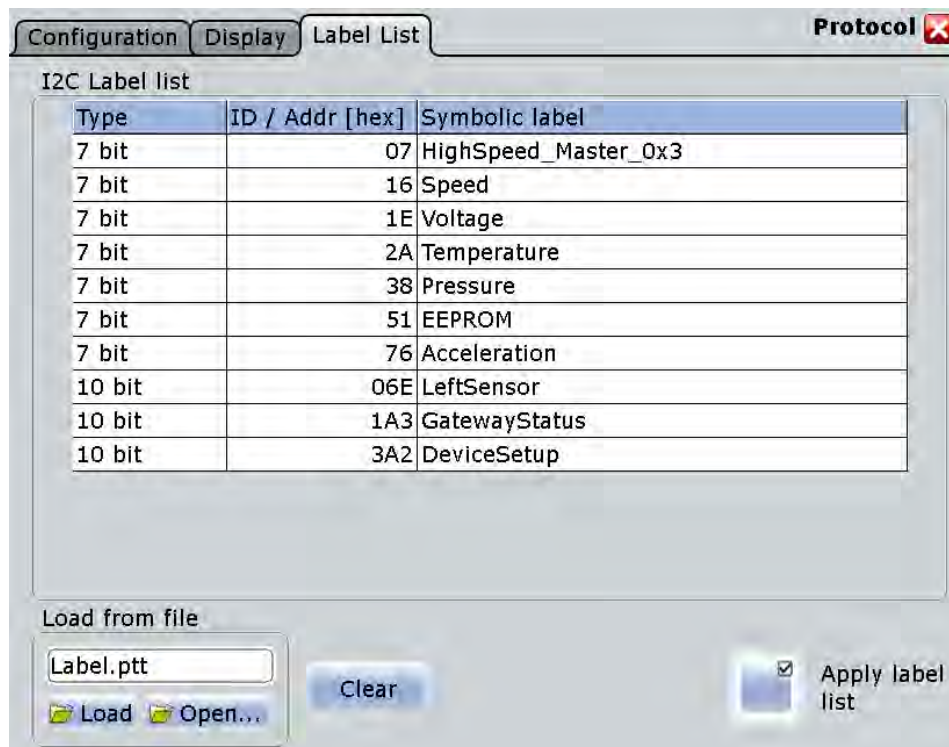

The common settings for all protocols are:

Load from file

Selects and loads a label list file. The file format is always PTT.

Label lists are protocol-specific. Their contents are described in the corresponding protocol chapters:

- [chapter 14.2.4, "I²C Label List"](#), on page 435
- [chapter 14.5.3, "CAN Label List"](#), on page 463
- [chapter 14.6.4, "LIN Label List"](#), on page 473
- [chapter 14.7.3, "FlexRay Label List"](#), on page 485

Clear

Deletes the label list from the instrument.

Apply label list

Activates the label list to be used for decoding. The "Label" appear in the "Decode results" table and in the frame captions of the decoded signal.

Remote command:

`BUS<m>:SYMBOLs` on page 957

14.1.4 Bit Pattern Editor

If you want to enter a specified address or data pattern, the bit pattern editor helps you to enter the pattern in various formats - decimal, hexadecimal, octal, binary and ASCII.



The editor displays the pattern in two columns. The left column always shows binary data. For the right column, you can select the format, the default depends on the data specifics. You can edit data in the left or right column. The keypad adapts itself to the column format, only keys appropriate to the format are enabled.

The data is grouped and converted in bit groups. The size of a bit group depends on the address or data specifics and is set by the instrument. Groups are automatically separated by blanks. The maximum size of a bit group is 64 bit, the most common group size is 1 byte.

"Overwrite mode": If disabled, the data behind the new digit is shifted to the right. Bit groups are rearranged automatically.

Format-specific information:

- Unsigned: Decimal data format without sign. It is available for I²C, SPI, UART, CAN, LIN and FlexRay protocols. If you enter a decimal number that is too large for the defined bit group, the number is truncated and a message appears. X (don't care) in the decimal column sets all binary digits of the bit group to X.
- Signed: Signed decimal format, available for audio protocols. The first bit represents the sign. You can use the 2's complement or 1's complement format.
- Binary: 0, 1 and X (don't care) are allowed.
- Hex: most common format in the right column.
- Octal: Each digit represents 3 bit.
- ASCII: In the ASCII column, "X" is the character X. The binary X (don't care) is not allowed. If an X is included in the binary value in the left column, the ASCII columns displays "\$" to indicate that the value is not defined.

Where applicable, frequently used values are provided in a "Predefined values" list below the pattern table, for example, reserved end words of data packets in the UART protocol.

14.2 I²C

The Inter-Integrated Circuit is a simple, low-bandwidth, low-speed protocol used for communication between on-board devices.

- [The I²C Protocol](#)..... 426
- [I²C Configuration](#)..... 428
- [I²C Trigger](#)..... 430
- [I²C Label List](#)..... 435
- [I²C Decode Results \(Option R&S RTO-K1\)](#)..... 436

14.2.1 The I²C Protocol

This chapter provides an overview of protocol characteristics, data format, address types and trigger possibilities. For detailed information, read the "I²C-bus specification and user manual" available on the NXP manuals web page at <http://www.nxp.com/>.

I²C characteristics

Main characteristics of I²C are:

- Two-wire design: serial clock (SCL) and serial data (SDA) lines
- Master-slave communication: the master generates the clock and addresses the slaves. Slaves receive the address and the clock. Both master and slaves can transmit and receive data.
- Addressing scheme: each slave device is addressable by a unique address. Multiple slave devices can be linked together and can be addressed by the same master.
- Read/write bit: specifies if the master will read (=1) or write (=0) the data.
- Acknowledge: takes place after every byte. The receiver of the address or data sends the acknowledge bit to the transmitter.

The R&S RTO supports all operating speed modes: high-speed, fast mode plus, fast mode, and standard mode.

Data transfer

The format of a simple I²C message (frame) with 7 bit addressing consists of the following parts:

- Start condition: a falling slope on SDA while SCL is high
- 7-bit address of the slave device that either will be written to or read from
- R/W bit: specifies if the data will be written to or read from the slave
- ACKnowledge bits: is issued by the receiver of the previous byte if the transfer was successful
Exception: At read access, the master terminates the data transmission with a NACK bit after the last byte.
- Data: a number of data bytes with an ACK bit after every byte
- Stop condition: a rising slope on SDA while SCL is high

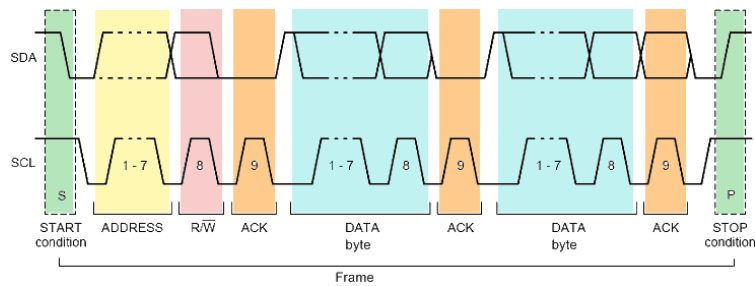

Fig. 14-1: I²C write access with 7-bit address

Address types: 7-bit and 10-bit

Slave addresses can be 7 or 10 bits long. A 7-bit address requires one byte, 7 bits for the address followed by the R/W bit.

A 10-bit address for write access requires two bytes: the first byte starts with the reserved sequence 11110, followed by the two MSB of the address and the write bit. The second byte contains the remaining 8 LSB of the address. The slave acknowledges each address byte.

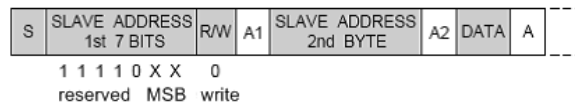

Fig. 14-2: 10-bit address, write access

A 10-bit address for read access requires three bytes. The first two bytes are identical to the write access address. The third byte repeats the address bits of the first byte and sets the read bit.

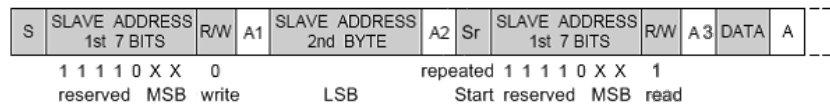

Fig. 14-3: 10-bit address, read access

Trigger

The R&S RTO can trigger on various parts of I²C messages. The data and clock lines must be connected to the input channels, triggering on math and reference waveforms is not possible.

You can trigger on:

- Start or stop condition
- Repeated start condition
- Transfer direction (read or write)
- Bytes with missing acknowledge bit
- Specific slave address or address range
- Specific data pattern in the message

14.2.2 I²C Configuration

14.2.2.1 Configuring I²C Protocol

The configuration of the I²C is simple - assign the two lines to input channels, and set the thresholds.

For details on configuration settings, see [chapter 14.2.2, "I²C Configuration"](#), on page 428.

To display the decoded signal, option R&S RTO-K1 is required.

1. Press the PROTOCOL key on the front panel.
2. At the left-hand side, select the vertical tab of the bus you want to set up.
3. Select the "Configuration" tab.
4. Tap the "Protocol" button and select the protocol: "I2C".
5. Optionally, you can enter a "Bus label" on the "Display" tab.
6. Tap the "SDA" button, and select the waveform of the data line.
7. Tap the "SCL" button, and select the waveform of the clock line.
8. Set the logical thresholds: Either according to technology definition with "Preset", or to the middle reference levels with "Set to 50%", or enter a user-defined value directly in the "Threshold" fields.

14.2.2.2 I²C Configuration Settings

Access: PROTOCOL > "Configuration" tab > "Protocol" = I2C



Make sure that the tab of the correct serial bus is selected on the left side.

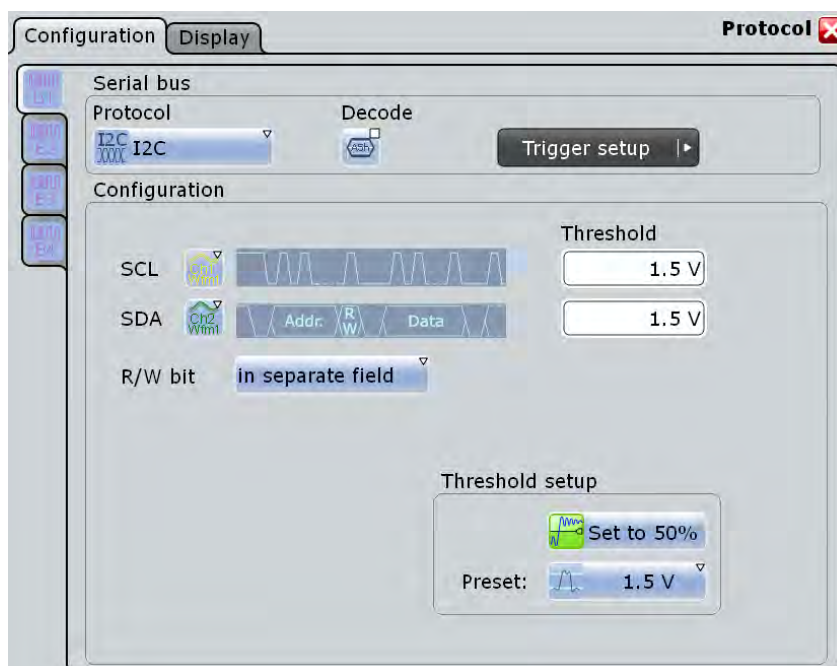

See also: [chapter 14.1.1, "Configuration - General Settings"](#), on page 420.

SDA, SCL

Set the waveforms of the data line (SDA) and clock line (SCL). Waveform 1 of channel signals, math waveforms, and reference waveforms can be used. Do not combine a reference waveform with channel or math waveform because the time correlation of these waveforms might differ.

Alternatively, digital channels can be used if MSO option R&S RTO-B1 is installed. Digital and analog channels cannot be used at the same time.

For triggering on a serial bus, analog or digital input channels are required. Math and reference waveforms are not available.

Remote command:

[BUS<m>: I2C: SDA: SOURce](#) on page 940

[BUS<m>: I2C: SCL: SOURce](#) on page 940

Threshold

Sets the threshold value for digitization of signals for each line. If the signal value on the line is higher than the threshold, the signal state is high (1 or true for the boolean logic). Otherwise, the signal state is considered low (0 or false) if the signal value is below the threshold.

There are three ways to set the threshold:

- "Threshold"
Enter the value directly in the field.
- "Set to 50%"
Executes the measurement of reference levels and sets the thresholds to the middle reference level of the measured amplitude.
- "Preset"

Selects the default threshold voltage for various signal technologies from a list. The value is set to "Manual" if the threshold was set with "Set to 50%", or was entered directly.

Note: If the sources are digital channels, the same threshold values are used for the parallel and the serial buses. You can set the thresholds either in the parallel bus configuration or in the serial bus configuration.

Remote command:

[BUS<m>:I2C:SCL:THReshold](#) on page 941

[BUS<m>:I2C:SDA:THReshold](#) on page 941

[BUS<m>:I2C:TECHnology](#) on page 941

[BUS<m>:SETRefllevels](#) on page 939

R/W bit

Defines if the R/W bit is considered separately or as part of the address. The setting affects the [Address setup](#) of the trigger conditions.

Remote command:

[BUS<m>:I2C:RWBit](#) on page 942

14.2.3 I²C Trigger

14.2.3.1 Triggering on I²C

Prerequisites: A I²C-bus is configured, see [chapter 14.2.2.1, "Configuring I²C Protocol"](#), on page 428. SDA and SCL lines are set to channel waveforms.

1. Press the TRIGGER key.
If the "Protocol Configuration" dialog box is open, you can tap the "Trigger Setup" button.
2. Tap the "Source" button and select the "Serial" trigger source.
3. Select the serial bus that is set to I²C.
4. Select the "Trigger type".
5. For more complex trigger types, enter the address and/or data conditions: address, acknowledge bits, R/W bit, and data pattern.
For details, see [chapter 14.2.3, "I²C Trigger"](#), on page 430

14.2.3.2 I²C Trigger Settings

Access: TRIGGER > "Source" = *Serial Bus* and "Protocol" = *I2C*



Make sure that:

- the trigger sequence is set to "A only"
- the trigger source is "Serial bus", and the data source(s) of the bus are channel signals
- the correct serial bus is selected
- the correct protocol is selected

Trigger type

Selects the trigger type for I²C analysis.

"Start" Sets the trigger to the start of the message. The start condition is a falling edge on SDA while SCL is high. The trigger instant is the falling edge of the SDA line. You can change the SDA and SCL lines here if necessary.



"Repeated start" Sets the trigger to a repeated start - when the start condition occurs without previous stop condition. Repeated start conditions occur when a master exchanges multiple messages with a slave without releasing the bus.



"Stop" Sets the trigger to the end of the message. The stop condition is a rising slope on SDA while SCL is high.



"No Ack (Missing Ack)" Missing acknowledge bit: the instrument triggers if the data line remains HIGH during the clock pulse following a transmitted byte. You can also localize specific missing acknowledge bits by setting the [No Ack conditions](#).

"Address" Sets the trigger to one specific address condition or a combination of address conditions. The trigger time is the falling clock edge of the acknowledge bit after the address.

- Address type
- Specified address or address range
- Read/Write bit

Description of trigger type specific settings: ["Address setup"](#) on page 433.

"Address OR" Triggers on one to four address conditions. Description of trigger type specific settings: ["Address OR conditions"](#) on page 434.

"Address and data" Sets the trigger to a combination of address and data condition. The address conditions are the same as for the "Address" trigger type, see ["Address setup"](#) on page 433 and ["Data setup"](#) on page 434.

Remote command:

`TRIGger<m>:I2C:MODE` on page 943

No Ack conditions

Selects which missing acknowledge bits is detected if the trigger type is set to "Missing Ack".

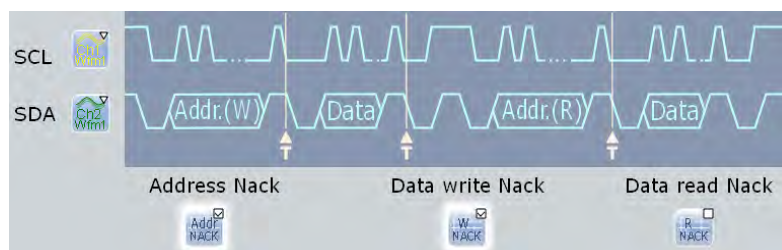

"Address Nack" No slave recognizes the address.

"Data write Nack" The addressed slave does not accept the data.

"Data read Nack" Marks the end of the read process when the master reads data from the slave. This Nack is sent according to the protocol definition, it is not an error.

Remote command:

[TRIGger<m>: I2C:ADNack](#) on page 944

[TRIGger<m>: I2C:DWNack](#) on page 944

[TRIGger<m>: I2C:DRNack](#) on page 944

Address setup

Specifies the address conditions:

The screenshot shows a dialog box titled "Address setup". It contains several fields and dropdown menus:

- Type:** A dropdown menu currently showing "7 bit".
- Condition:** A dropdown menu currently showing "<".
- Addr. min:** A text input field containing "[hex]00".
- R/W bit:** A dropdown menu currently showing "Write".
- Addr. max:** A text input field containing "[hex]00".

Type ← Address setup

Sets the address length to be triggered on: 7 bit, 7+1 bit, or 10 bit. Available settings depend on the [R/W bit](#) setting of the bus configuration.

For "7 bit" and "10 bit", enter the address bits in the [Addr. min / Addr. max](#) field, and use the ["R/W bit"](#) on page 434 field to select the transfer direction.

For "7+1 bit", enter the seven address bits and also the R/W bit in the "Address" field.

If the trigger type is "Address + data", you can set the address type "Any" to trigger on data only, regardless of the address.

Remote command:

[TRIGger<m>: I2C:AMODe](#) on page 945

Addr. min / Addr. max ← Address setup

Defines the bit pattern of the slave device address. The length of the entry is adjusted to the selected address type. In binary format, use the following characters: 1; 0; or X (any bit). The use of X is restricted to the "Address operator"s "Equal" and "Not equal".

The bit pattern editor helps you to enter the pattern in any format, see [chapter 14.1.4, "Bit Pattern Editor"](#), on page 425.

Depending on the [Condition](#), a specific address or an address range must be defined.

To trigger on any address, set the "Address operator" to "Equal" and enter X for each address bit.

Remote command:

[TRIGger<m>: I2C:ADDRes](#) on page 945

[TRIGger<m>: I2C:ADDTo](#) on page 946

Condition ← Address setup

Sets the operator to set a specific address ("Equal" or "Not equal") or an address range. The address values are set with [Addr. min / Addr. max](#).

Remote command:

[TRIGger<m>:I2C:ACONdition](#) on page 945

R/W bit ← Address setup

Toggles the trigger condition between Read and Write access of the master. Select "Either" if the transfer direction is not relevant for the trigger condition.

Remote command:

[TRIGger<m>:I2C:ACCess](#) on page 943

Address OR conditions

Triggers on one to four address conditions. For each condition to be used, select "Monitor".

Each condition requires an exact address. The definition of address ranges is not possible here. X (don't care) can be used.

Remote command:

[TRIGger<m>:I2C:ADOR<n>:ENABle](#) on page 946

[TRIGger<m>:I2C:ADOR<n>:ADRTYPE](#) on page 946

[TRIGger<m>:I2C:ADOR<n>\[:VALue\]](#) on page 947

[TRIGger<m>:I2C:ADOR<n>:RWBit](#) on page 947

Data setup

Specifies the data conditions:

Data setup		
Position	Index min	Index max
=	0	0
Condition	Value min	
=	[bin]0	
	Value max	
	[hex]0	

Position ← Data setup

Operator for the data position within a frame. You can define an exact position, or a position range. Select "Any", if the position of the required pattern is not relevant.

Remote command:

[TRIGger<m>:I2C:DPOPerator](#) on page 947

Index min, Index max ← Data setup

Sets the number of data bytes to be skipped after the address. The index 0 is associated with the first data byte. If the [Position](#) defines a range, the first and the last byte of interest are defined.

Remote command:

[TRIGger<m>:I2C:DPOsition](#) on page 948

[TRIGger<m>:I2C:DPTO](#) on page 948

Condition ← Data setup

Selects the operator for the "Data" pattern: "Equal", "Not equal", or a range definition.

Remote command:

[TRIGger<m>:I2C:DCONdition](#) on page 948

Value min / Value max ← Data setup

Specifies the data bit pattern. Enter the bytes in msb first bit order. The maximum pattern length is 64 bit. Waveform data is compared with the pattern byte-by-byte.

The instrument ensures that the max value is always \geq the min value, and X bits (don't care) are at the same position in both values.

The bit pattern editor helps you to enter the pattern, see [chapter 14.1.4, "Bit Pattern Editor"](#), on page 425.

Remote command:

[TRIGger<m>:I2C:DMIN](#) on page 949

[TRIGger<m>:I2C:DMAX](#) on page 949

14.2.4 I²C Label List

Label lists are protocol-specific. An I²C PTT file contains three values for each address:

- "Type": address type, 7-bit or 10-bit long
- "ID / Addr": hexadecimal address value
- "Symbolic label": name of the address, specifying its function in the bus network.

Example: I²C PTT file

```
# -----
@FILE_VERSION = 1.00
@PROTOCOL_NAME = i2c
# -----
# Labels for I2C protocol
# Column order: Identifier type, Identifier value, Label
# -----
7,0x1E,Voltage
7,0x38,Pressure
7,0x2A,Temperature
7,0x16,Speed
7,0x76,Acceleration
7,0x07,HighSpeed_Master_0x3
```

```

7, 0x51, EEPROM
10, 0x3A2, DeviceSetup
10, 0x1A3, GatewayStatus
10, 0x06E, LeftSensor
# -----

```

To use label lists, option R&S RTO-K1 is required.

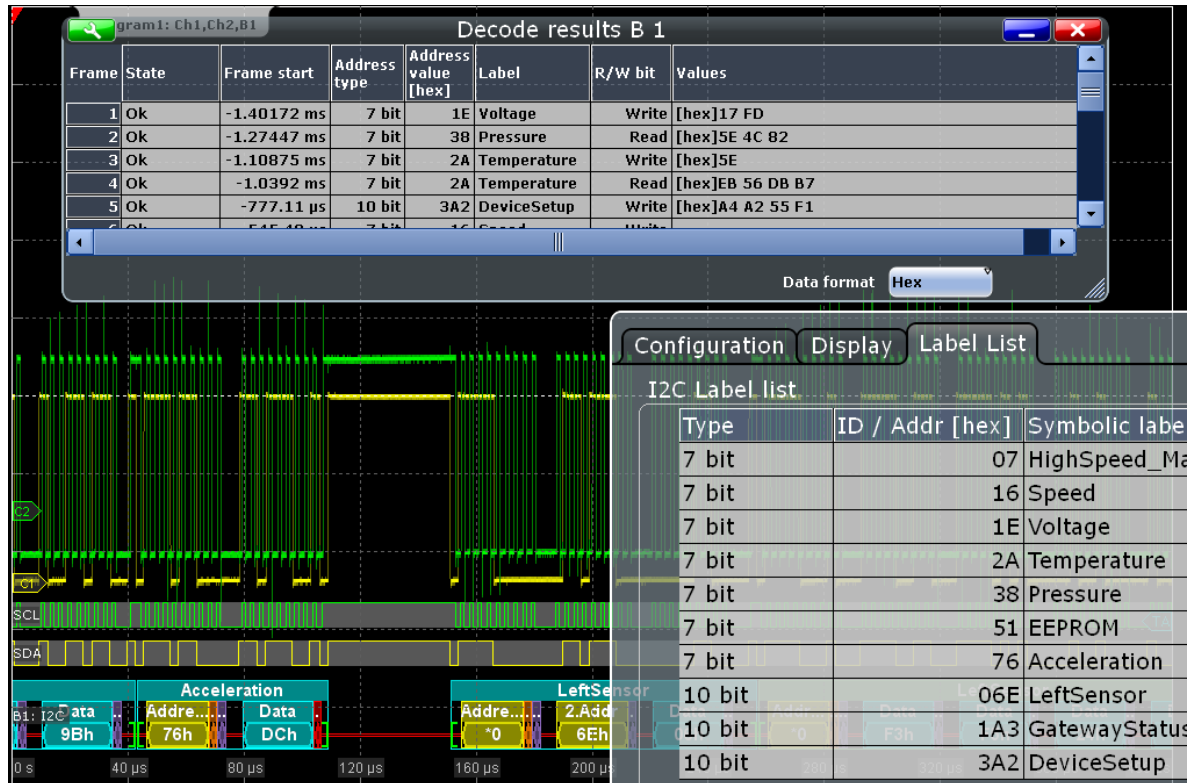

For general information on the "Label List" tab, see [chapter 14.1.3, "Label Lists"](#), on page 422.

SCPI command

- `BUS<m>:I2C:FRAME<n>:SYMBOL?` on page 958

14.2.5 I²C Decode Results (Option R&S RTO-K1)

If the option is installed, the "Decode" function in the "Configuration" tab is available. Enable "Decode" to display the decoded signal below the waveforms.

Additionally, you can display the binary signal and the detailed decoding results, see [chapter 14.1.2, "Display"](#), on page 420.

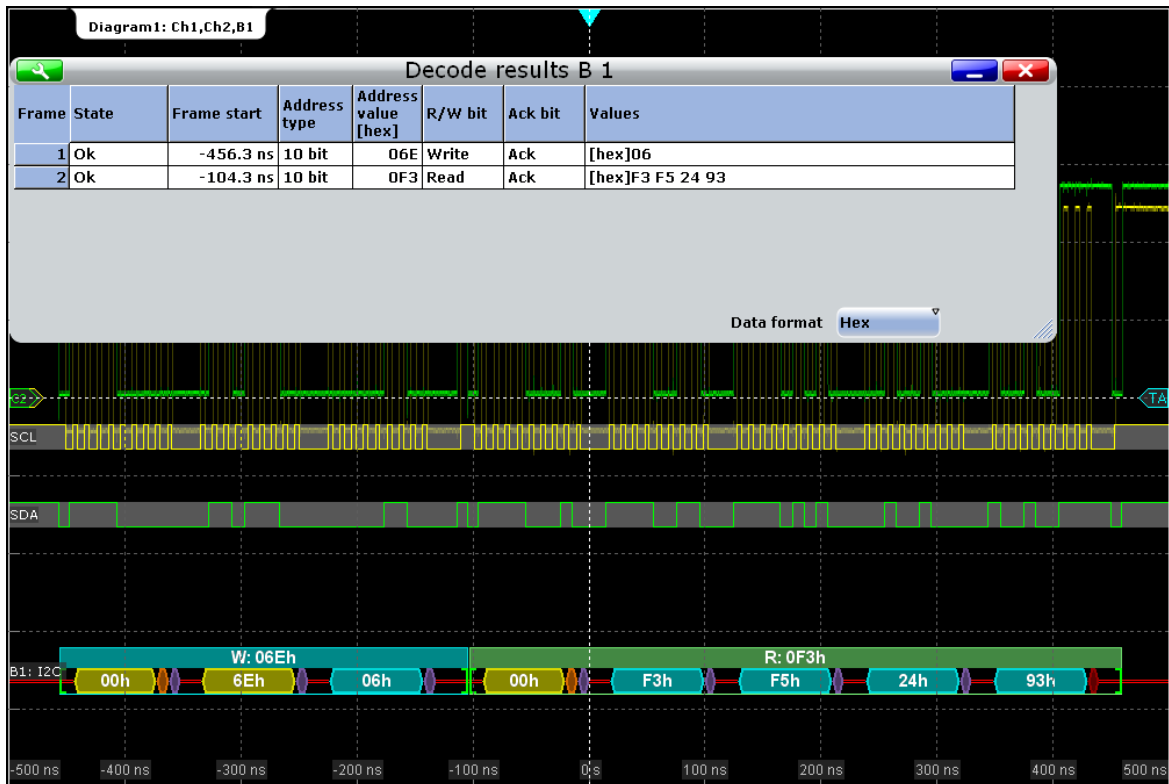

Fig. 14-4: Decoded and binary I2C signal, and decode results

- green brackets [...] = start and end of frame
- blue frame header = write frame ok, with transfer direction and address value
- green frame header = read frame ok, with transfer direction and address value
- yellow = address
- blue = correct data
- light orange = R/W bit
- purple = acknowledge bit
- red = No ack (missing acknowledge bit)

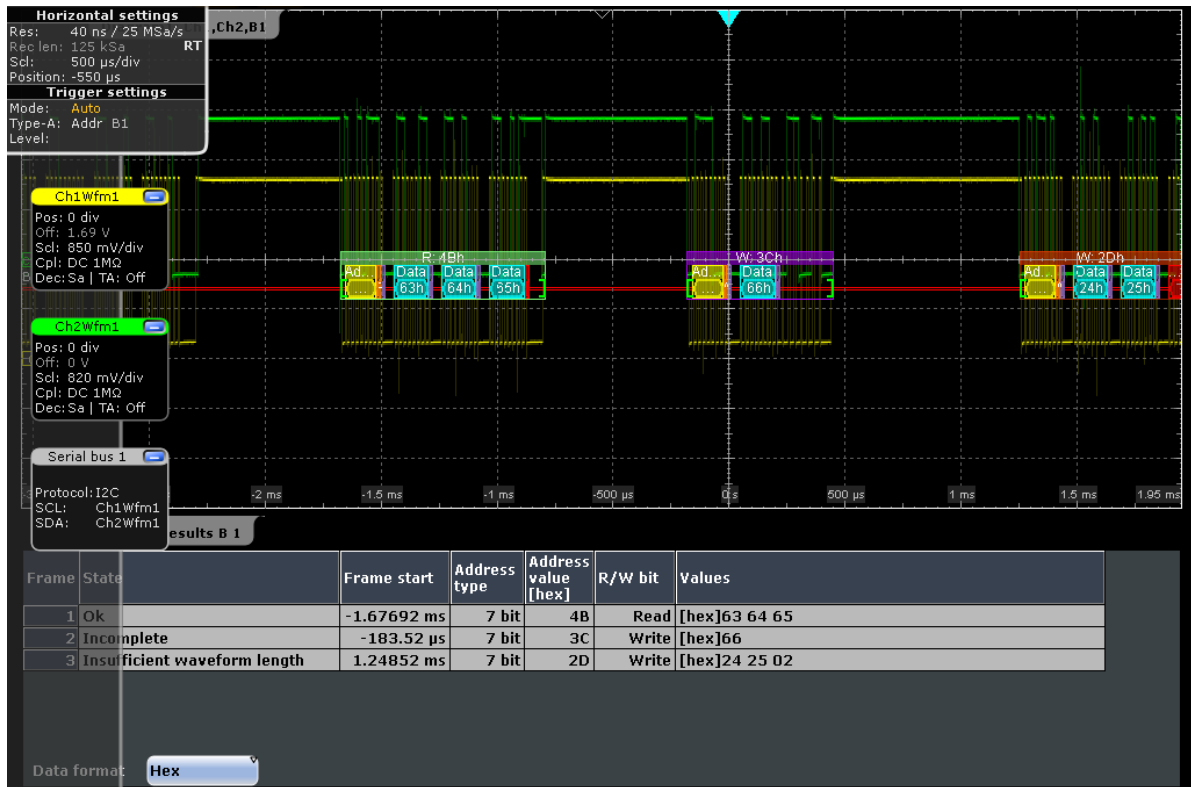

Fig. 14-5: Decoded I2C signal with incomplete data, and decode results

- magenta frame header = incomplete frame, missing bits in data words
- dark orange frame header = insufficient frame (end of acquisition before decoding has been completed), with transfer direction and address value
- red = insufficient data word (end of acquisition before end of word)

The "Decode results" box shows the detailed decoded data for each data frame.

Table 14-1: Content of the "Decode results" table

Column	Description
State	Overall state of the frame. "Insufficient waveform length" indicates that the frame is not completely contained in the acquisition. Change the horizontal scale, or move the reference point to the left to get a longer acquisition.
Frame start	Time of frame start
Address type	Address length, 7 bit or 10 bit
Address value (hex)	Hexadecimal value of the address
R/W bit	Value of the R/W bit
Ack bit	Value of the address acknowledge bit
Values	Value of all data bytes of the frame. The data format is selected below the table.

Example:

The signal in [figure 14-4](#) shows a write access followed by a read access, both with 10bit address. The decoded data shows a No Ack bit at the end of the read data. This No Ack bit is sent according to the protocol definition and is not an error. Thus, the decode results in the table indicate "Ack" for the second frame.

SCPI commands:

- [BUS<m>:I2C:FRAMe<n>:DATA?](#) on page 950
- [BUS<m>:I2C:FCOunt?](#) on page 950
- [BUS<m>:I2C:FRAMe<n>:AACcess?](#) on page 950
- [BUS<m>:I2C:FRAMe<n>:ACCess?](#) on page 951
- [BUS<m>:I2C:FRAMe<n>:ACOMplete?](#) on page 951
- [BUS<m>:I2C:FRAMe<n>:ADBStart?](#) on page 951
- [BUS<m>:I2C:FRAMe<n>:ADDRess?](#) on page 952
- [BUS<m>:I2C:FRAMe<n>:ADEVICE?](#) on page 952
- [BUS<m>:I2C:FRAMe<n>:AMODE?](#) on page 952
- [BUS<m>:I2C:FRAMe<n>:ASStart?](#) on page 953
- [BUS<m>:I2C:FRAMe<n>:RWBStart?](#) on page 953
- [BUS<m>:I2C:FRAMe<n>:STATus?](#) on page 953
- [BUS<m>:I2C:FRAMe<n>:STARt?](#) on page 954
- [BUS<m>:I2C:FRAMe<n>:STOP?](#) on page 954
- [BUS<m>:I2C:FRAMe<n>:BCOunt?](#) on page 955
- [BUS<m>:I2C:FRAMe<n>:BYTE<o>:ACCess?](#) on page 955
- [BUS<m>:I2C:FRAMe<n>:BYTE<o>:ACKStart?](#) on page 955
- [BUS<m>:I2C:FRAMe<n>:BYTE<o>:COMplete?](#) on page 956
- [BUS<m>:I2C:FRAMe<n>:BYTE<o>:STARt?](#) on page 956
- [BUS<m>:I2C:FRAMe<n>:BYTE<o>:VALue?](#) on page 957

14.3 SPI Bus

- [The SPI Protocol](#)..... 439
- [SPI Configuration](#)..... 440
- [SPI Trigger](#)..... 444
- [SPI Decode Results \(Option R&S RTO-K1\)](#)..... 447

14.3.1 The SPI Protocol

A 4-channel instrument is required for full support of the SPI protocol.

The Serial Peripheral Interface SPI is used for communication with slow peripheral devices, in particular, for transmission of data streams.

Main characteristics of SPI are:

- Master-slave communication
- No device addressing; The slave is accessed by a chip select, or slave select line.
- No acknowledgement mechanism to confirm receipt of data
- Duplex capability

Most SPI buses have four lines, two data and two control lines:

- Clock line to all slaves (SCLK)
- Slave Select or Chip Select line (SS or CS)
- Master data output, slave data input (MOSI or SDI)
- Master data input, slave data output (MISO or SDO)

When the master generates a clock and selects a slave device, data may be transferred in either or both directions simultaneously.

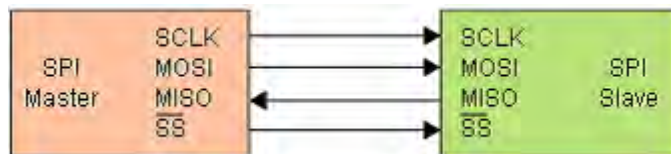

Fig. 14-6: Simple configuration of SPI bus

The data bits of a message are grouped by following criteria:

- A word contains a number of successive bits. The word length is defined in the protocol configuration.
- A frame contains a number of successive words, at least one word.

For SPI buses, the R&S RTO provides the following trigger possibilities:

- On frame start
- On a serial pattern
- On a serial pattern at a specified position

14.3.2 SPI Configuration

14.3.2.1 Configuring SPI Signals

For configuration, assign the lines to the input channels, and define the active states and the logical thresholds.

For details on configuration settings, see [chapter 14.3.2, "SPI Configuration"](#), on page 440.

1. Press the PROTOCOL key on the front panel.

2. At the left hand-side, select the vertical tab of the bus you want to set up.
3. Select the "Configuration" tab.
4. Tap the "Protocol" button and select the protocol: "SPI".
5. Optionally, you can enter a "Bus label" in the "Display" tab.
6. Tap the "SCLK Source" button, and select the waveform of the clock line.
7. Set the polarity (clock mode) for SCLK.
8. For each of the available SS, MISO and MOSI lines, assign the waveform and define the polarity (active state) of the line.
9. Set the logical thresholds: Either according to technology definition with "Preset", or to the middle reference levels with "Set to 50%", or enter a user-defined value directly in the "Threshold" fields.
10. Set the "Bit order", "Word length", and "Frame condition" according to your signal.

14.3.2.2 SPI Configuration Settings

Access: PROTOCOL > "Configuration" tab > "Protocol" = SPI



Make sure that the tab of the correct serial bus is selected on the left side.

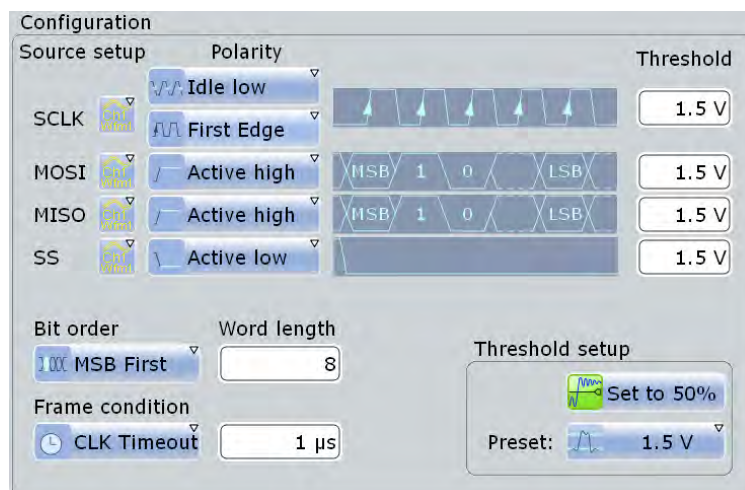

See also: [chapter 14.1.1, "Configuration - General Settings"](#), on page 420.

SCLK

Defines the settings for the clock line.

SCLK source ← SCLK

Sets the input channel of the clock line. Waveform 1 of channel signals, math waveforms, and reference waveforms can be used for decoding.

Alternatively, digital channels can be used if MSO option R&S RTO-B1 is installed. Digital and analog channels cannot be used at the same time.

For triggering on a serial bus, analog or digital input channels are required. Math and reference waveforms are not available.

Remote command:

[BUS<m>:SPI:SCLK:SOURce](#) on page 959

Polarity ← SCLK

Two settings define the clock mode: the clock polarity and the clock phase. Together, they determine the edges of the clock signal on which the data are driven and sampled. A master/slave pair must use the same parameter pair values to communicate.

The clock polarity is "Idle low" (idle = 0) or "Idle high" (idle = 1).

The clock phase defines the slope. It selects if data is stored with the rising or falling slope of the clock. The slope marks the begin of a new bit.

SS, MISO, MOSI

Configures the Slave Select, MISO and MOSI lines.

Source ← SS, MISO, MOSI

Sets the input channel of the selected line. Waveform 1 of channel signals, math waveforms, reference waveforms, or no waveform can be selected.

Alternatively, digital channels can be used if MSO option R&S RTO-B1 is installed. Digital and analog channels cannot be used at the same time.

For triggering on a serial bus, analog or digital input channels are required. Math and reference waveforms are not available.

Remote command:

[BUS<m>:SPI:SSElect:SOURce](#) on page 959

[BUS<m>:SPI:MISO:SOURce](#) on page 960

[BUS<m>:SPI:MOSI:SOURce](#) on page 961

Polarity ← SS, MISO, MOSI

Selects whether transmitted data or the slave select signal is high active (high = 1) or low active (low = 1).

Remote command:

[BUS<m>:SPI:SSElect:POLarity](#) on page 960

[BUS<m>:SPI:MISO:POLarity](#) on page 960

[BUS<m>:SPI:MOSI:POLarity](#) on page 961

Threshold

Sets the threshold value for digitization of signals for each line. If the signal value on the line is higher than the threshold, the signal state is high. Otherwise, the signal state is considered low if the signal value is below the threshold. The interpretation of HIGH and LOW is defined by the [Polarity](#).

There are three ways to set the threshold:

- "Threshold"
Enter the value directly in the field.

- "Set to 50%"
Executes the measurement of reference levels and sets the thresholds to the middle reference level of the measured amplitude.
- "Preset"
Selects the default threshold voltage for various signal technologies from a list. The value is set to "Manual" if the threshold was set with "Set to 50%", or was entered directly.

Note: If the sources are digital channels, the same threshold values are used for the parallel and the serial buses. You can set the thresholds either in the parallel bus configuration or in the serial bus configuration.

Remote command:

[BUS<m>:SPI:SCLK:THReshold](#) on page 962

[BUS<m>:SPI:MISO:THReshold](#) on page 962

[BUS<m>:SPI:MOSI:THReshold](#) on page 962

[BUS<m>:SPI:SSElect:THReshold](#) on page 962

[BUS<m>:SPI:TECHnology](#) on page 961

[BUS<m>:SETReflevels](#) on page 939

Bit order

Defines if the data of the messages starts with msb (most significant bit) or lsb (least significant bit). The display of the decoded signal considers this setting, results are displayed in the specified order.

Remote command:

[BUS<m>:SPI:BORDER](#) on page 958

Word length

Sets the number of bits in a word. The maximum length is 32 bit.

Remote command:

[BUS<m>:SPI:WSIZE](#) on page 959

Frame condition

Defines the start of a frame. A frame contains a number of successive words, at least one word.

"SS" Start and end of the frame is defined by the active state of the slave select signal.

"CLK timeout" Defines a timeout on the clock line SCLK as limiter between two frames. The timeout condition is used for SPI connections without an SS line. Enter the minimum clock idle time in the field.

Remote command:

[BUS<m>:SPI:FRCondition](#) on page 962

Timeout

Sets the minimum clock idle time if a timeout on the clock line SCLK is used as limiter between two frames.

See also: "[Frame condition](#)" on page 443.

Remote command:

`BUS<m>:SPI:TIMEout` on page 963

14.3.3 SPI Trigger

14.3.3.1 Triggering on SPI

Prerequisites: A bus is configured for the SPI signal to be analyzed.

1. Press the TRIGGER key.
2. Tap the "Source" button and select the "Serial" trigger source.
3. Select the serial bus that is set to SPI.
4. Select the "Trigger type".
5. For more complex trigger types, enter the data pattern conditions
For details, see [chapter 14.3.3, "SPI Trigger"](#), on page 444

14.3.3.2 SPI Trigger

Access: TRIGGER > "Source" = *Serial Bus* and "Protocol" = *SPI*

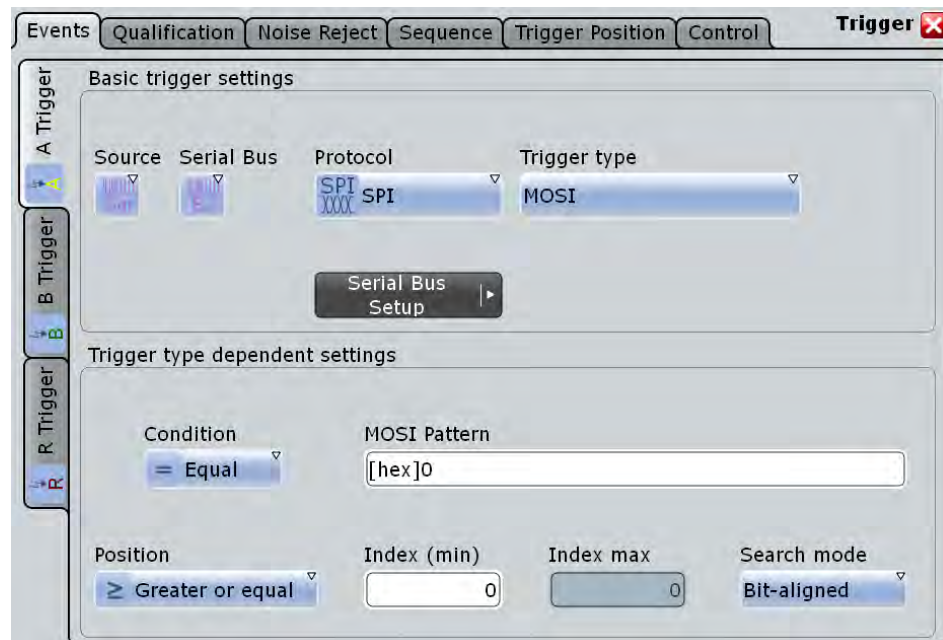



Make sure that:

- the trigger sequence is set to "A only"
- the trigger source is "Serial bus", and the data source(s) of the bus are channel signals
- the correct serial bus is selected
- the correct protocol is selected

Trigger type

Selects the trigger type for SPI analysis.

"Frame start (SS)" Trigger on the start of the frame when the slave select signal SS changes to the active state. This trigger type is available if [Frame condition](#) is set to "SS".

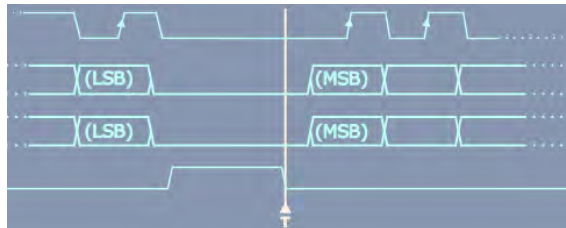

"Frame start (Timeout)" Triggers on the start of the frame when the clock idle time exceeds the "Timeout" time. This trigger type is available if [Frame condition](#) is set to "CLK timeout".

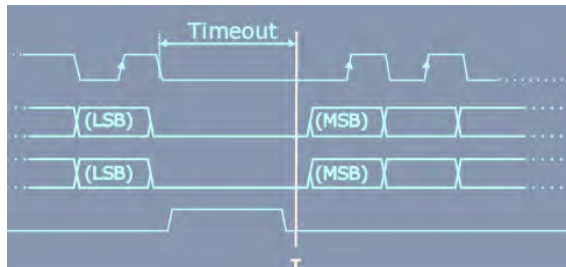

"MOSI" Sets the trigger to a specified data pattern expected on the MOSI line.

See: ["MOSI and MISO data conditions"](#) on page 445.

"MISO" Sets the trigger to a specified data pattern expected on the MISO line.

See: ["MOSI and MISO data conditions"](#) on page 445.

"MOSI/MISO" Sets the trigger to specified data patterns expected on the MOSI and MISO lines.

Remote command:

`TRIGger<m>:SPI:MODE` on page 963

MOSI and MISO data conditions

The trigger on MOSI and MISO patterns is defined in the same way:

The screenshot shows a configuration window for SPI data conditions. It includes the following fields and controls:

- Condition:** A dropdown menu currently set to "Equal".
- MOSI Pattern:** A text input field containing "[hex]0".
- MISO Pattern:** A text input field containing "[hex]0".
- Position:** A dropdown menu currently set to "Greater or equal".
- Index min:** A text input field containing "0".
- Index max:** A text input field containing "0".
- Search mode:** A dropdown menu currently set to "Bit-aligned".

Condition ← MOSI and MISO data conditions

Selects the operator for the "Data" pattern: "Equal" or "Not equal".

Remote command:

[TRIGGER<m>:SPI:FCONDITION](#) on page 965

MOSI pattern, MISO pattern ← MOSI and MISO data conditions

Specifies the data pattern to be found on the MOSI or MISO line, respectively. Enter the words in msb first bit order. The maximum pattern length is 256 bit if one pattern is defined. If both MOSI and MISO patterns are used, the maximum pattern length of each pattern is 128 bit. The starting point of the pattern is defined by [Index min](#), [Index max](#) and [Search mode](#).

The bit pattern editor helps you to enter the pattern, see [chapter 14.1.4, "Bit Pattern Editor"](#), on page 425.

Remote command:

[TRIGGER<m>:SPI:MOSIPATTERN](#) on page 966

[TRIGGER<m>:SPI:MISOPATTERN](#) on page 966

Position ← MOSI and MISO data conditions

Operator for the data position. You can define an exact position, a position range, or let the position undefined ("Any").

Remote command:

[TRIGGER<m>:SPI:DPOPERATOR](#) on page 964

Index min, Index max ← MOSI and MISO data conditions

The effect of data positioning depends on the [Search mode](#). It sets the number of bits or words before the first word of interest. These offset bits/words are skipped. If the position operator defines a range, the first and the last bit/word of interest are defined. The index 0 is associated with the first data bit or word.

Remote command:

[TRIGGER<m>:SPI:DPOSITION](#) on page 965

[TRIGGER<m>:SPI:DPTO](#) on page 965

Search mode ← MOSI and MISO data conditions

Defines how the specified data pattern is searched:

"Word-aligned" The pattern is matched only at word boundaries.

"Bit-aligned" Bit-by-bit: the pattern can start at any position in the message.

Remote command:

[TRIGGER<m>:SPI:PALIGNMENT](#) on page 964

14.3.4 SPI Decode Results (Option R&S RTO-K1)

If the option is installed, the "Decode" function in the "Configuration" tab is available. Enable "Decode" to display the decoded signal below the waveforms.

Additionally, you can display the binary signal and the detailed decoding results, see [chapter 14.1.2, "Display"](#), on page 420.



Fig. 14-7: Decoded and binary SPI signal with SCLK, MOSI, and SS line

- green brackets [...] = start and end of complete frame
- red brackets [...] = start and end of incomplete frame
- yellow = word
- red = error

The "Decode results" box shows the detailed decoded data for each data frame.

Frame	State	Frame start	Frame stop	Word Count	MOSI Values	MISO Values
1	Ok	-22.268 µs	-10.156 µs	2	---	[hex]6C 55
2	Ok	6.76 µs	18.872 µs	2	---	[hex]6C 55
3	Ok	35.788 µs	47.904 µs	2	---	[hex]6C 55
4	Incomplete last word	64.82 µs	74.996 µs	1	---	[hex]6C

Data format Hex

Fig. 14-8: Decode results

Table 14-2: Content of the "Decode results" table

Column	Description
State	Overall state of the frame
Frame start , Frame stop	Times of frame start and frame end
Word count	Number of words in the frame
MOSI values	Value of the MOSI data words. The data format is selected below the table.
MISO values	Value of the MISO data words. The data format is selected below the table.

Example:

In the figure above, the first three frames contain two words each. The fourth frame is incomplete, only one word of the frame was recognized

SCPI commands:

- [BUS<m>:SPI:FRAMe<n>:DATA?](#) on page 967
- [BUS<m>:SPI:FCOunt?](#) on page 967
- [BUS<m>:SPI:FRAMe<n>:STATus?](#) on page 967
- [BUS<m>:SPI:FRAMe<n>:START?](#) on page 968
- [BUS<m>:SPI:FRAMe<n>:STOP?](#) on page 968
- [BUS<m>:SPI:FRAMe<n>:WCOunt?](#) on page 969
- [BUS<m>:SPI:FRAMe<n>:WORD<o>:START?](#) on page 969
- [BUS<m>:SPI:FRAMe<n>:WORD<o>:STOP?](#) on page 969
- [BUS<m>:SPI:FRAMe<n>:WORD<o>:MISO?](#) on page 970
- [BUS<m>:SPI:FRAMe<n>:WORD<o>:MOSI?](#) on page 970

14.4 UART / RS232

14.4.1 The UART / RS232 Interface

The Universal Asynchronous Receiver/Transmitter UART converts a word of data into serial data, and vice versa. It is the base of many serial protocols like of RS-232. The UART uses only one line, or two lines for transmitter and receiver.

Data transfer

The data is transmitted in words, also referred to as symbols or characters. Each word consists of a start bit, several data bits, an optional parity bit, and one or more stop bits. Several words can form a package, or frame. The end of a package is marked with a reserved word or by a pause between two words.

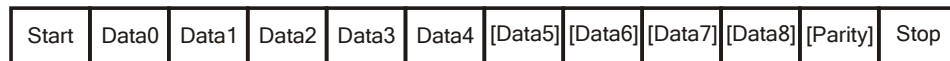

Fig. 14-9: Bit order in a UART word (symbol)

- The start bit is a logic 0.
- The stop bits and the idle state are always logic 1.

The UART protocol has no clock for synchronization. The receiver synchronizes by means of the start and stop bits, and the bit rate that must be known to the receiver.

Trigger

The R&S RTO can trigger on specified parts of UART serial signals:

- Start bit
- Packet start
- Parity errors, and breaks
- Stop errors
- A serial pattern at any or a specified position

14.4.2 UART Configuration

Access: PROTOCOL > "Configuration" tab > "Protocol" = *UART / RS232*



Make sure that the tab of the correct serial bus is selected on the left side.

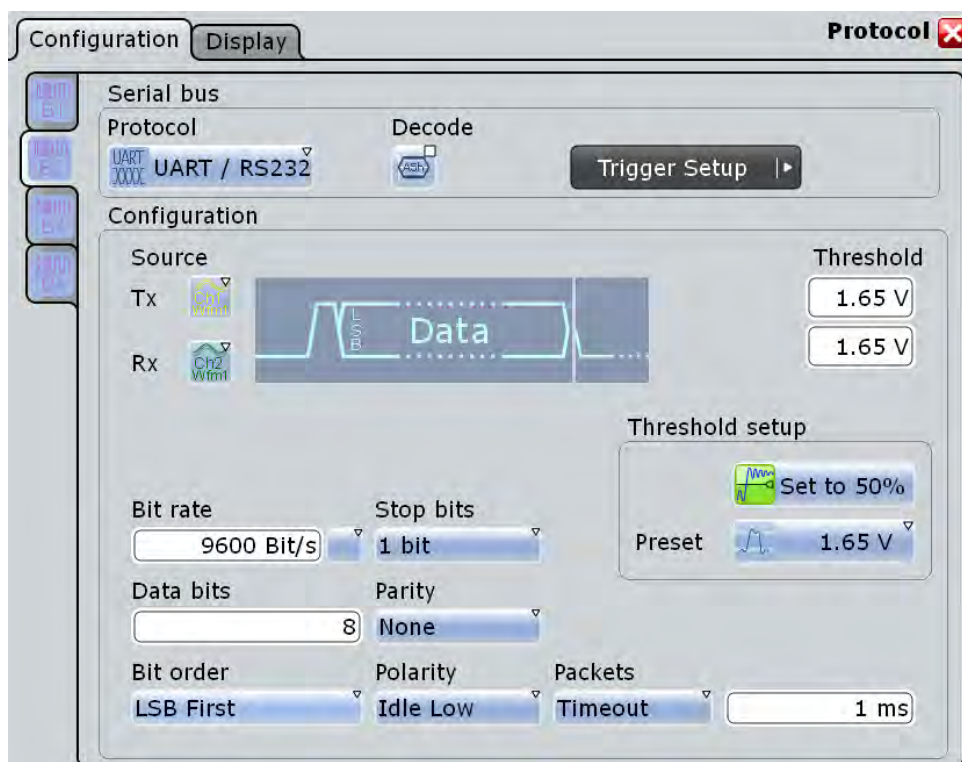

See also: [chapter 14.1.1, "Configuration - General Settings"](#), on page 420.

Source: Tx, Rx

Select the input channels for the transmitter and receiver signals.

Alternatively, digital channels can be used if MSO option R&S RTO-B1 is installed. Digital and analog channels cannot be used at the same time.

For triggering on a serial bus, analog or digital input channels are required. Math and reference waveforms are not available.

Remote command:

[BUS<m>:UART:TX:SOURce](#) on page 971

[BUS<m>:UART:RX:SOURce](#) on page 971

Threshold

Sets the threshold value for digitization of signals for each line. If the signal value on the line is higher than the threshold, the signal state is high. Otherwise, the signal state is considered low if the signal value is below the threshold. The interpretation of HIGH and LOW is defined by the [Polarity](#).

There are three ways to set the threshold:

- "Threshold"
Enter the value directly in the field.
- "Set to 50%"
Executes the measurement of reference levels and sets the thresholds to the middle reference level of the measured amplitude.
- "Preset"

Selects the default threshold voltage for various signal technologies from a list. The value is set to "Manual" if the threshold was set with "Set to 50%", or was entered directly.

Note: If the sources are digital channels, the same threshold values are used for the parallel and the serial buses. You can set the thresholds either in the parallel bus configuration or in the serial bus configuration.

Remote command:

[BUS<m>:UART:RX:THReshold](#) on page 972

[BUS<m>:UART:TX:THReshold](#) on page 972

[BUS<m>:UART:TECHnology](#) on page 972

[BUS<m>:SETRefllevels](#) on page 939

Polarity

Defines the logic levels of the bus. The idle state corresponds to a logic 1. the start bit to a logic 0. "Idle high" (high=1) is used, for example, for control signals, while "Idle low" (low=1) is defined for data lines (RS-232).

Remote command:

[BUS<m>:UART:POLarity](#) on page 974

Bit rate

Sets the number of transmitted bits per second. To select a bit rate from list of predefined values, tap the icon beside the "Bit rate" field. To enter a specific value, open the keypad. The list of predefined values is also available in the keypad.

Remote command:

[BUS<m>:UART:BITRate](#) on page 973

[BUS<m>:UART:BAUDrate](#) on page 973

Data bits

Sets the number of data bits of a word in a range from 5 to 8 bits.

Remote command:

[BUS<m>:UART:SSIZE](#) on page 975

Bit order

Defines if a word starts with msb (most significant bit) or lsb (least significant bit). The display of the decoded signal considers this setting, results are displayed in the specified order.

Stop bits

Sets the number of stop bits: 1 or 1.5 or 2 stop bits are possible.

Remote command:

[BUS<m>:UART:SBIT](#) on page 974

Parity

Defines the optional parity bit that is used for error detection.

"None" No parity bit is used.

"Odd" The parity bit is set to "1" if the number of data bits set to "1" is even.

"Even"	The parity bit is set to "1" if the number of data bits set to "1" is odd.
"Mark"	The parity bit is always a logic 1.
"Space"	The parity bit is always a logic 0.
"Don't care"	The parity is ignored.

Remote command:

[BUS<m>:UART:PARity](#) on page 973

Packets

Allows to define packets of several words in the data stream.

"None"	Packets are not considered.
"End word"	<p>Defines a pattern as end condition of a packet, for example, a reserved word like CR or LF. The bit pattern editor provides frequently used values in the "Predefined values" list below the pattern table.</p> <p>A new packet starts with the first start bit after the defined end pattern.</p>

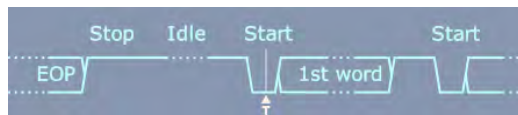

"Timeout"	<p>Defines a timeout between a stop bit and the next start bit. Enter the minimum time that marks the end of a packet.</p> <p>A new packet starts with the first start bit after the timeout.</p>
-----------	---

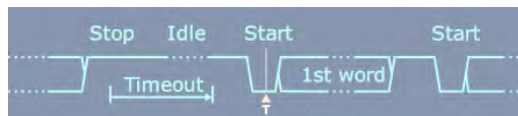

Remote command:

[BUS<m>:UART:BITime](#) on page 974

14.4.3 UART Trigger

The "Events" tab of the "Trigger" dialog box provides the trigger settings for the configured serial buses.

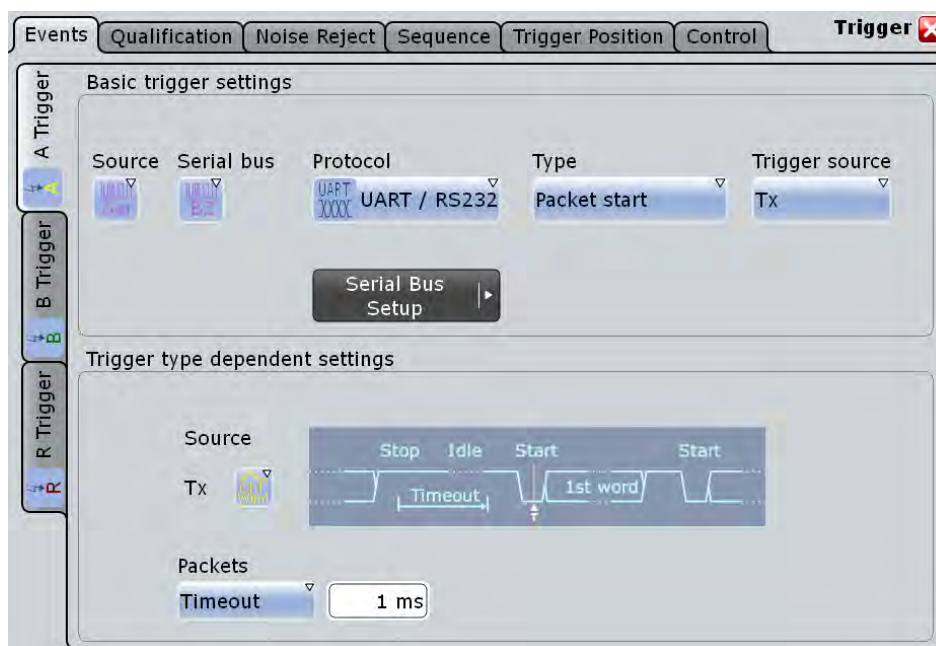

Make sure that:

- the trigger sequence is set to "A only"
- the trigger source is "Serial bus", and the data source(s) of the bus are channel signals
- the correct serial bus is selected
- the correct protocol is selected

Type

Selects the trigger type for UART analysis.

- | | |
|-------------------|--|
| "Start bit" | Triggers on a start bit. The start bit is the first low bit after a stop bit. |
| "Packet start" | Triggers on the begin of a data packet. The frame start is configured with " Packets " on page 452. |
| "Data" | Trigger on a serial pattern at a defined position in the data packet. The pattern can include several subsequent symbols (data frames). See " Data conditions " on page 454. |
| "Parity error" | Triggers on a parity error indicating a transmission error. This trigger type is only available if a parity is configured for the UART bus. |
| "Break condition" | Triggers if a start bit is not followed by a stop bit, the data line remains at logic 0 for longer than a UART word. |
| "Stop error" | Triggers if the stop bit is a logic 0. |

Remote command:

[TRIGger<m>:UART:TYPE](#) on page 975

Trigger source

Selects the transmitter or receiver line as trigger source.

Remote command:

[TRIGger<m>:UART:SOURce](#) on page 976

Data conditions

Specify the data conditions if the trigger type is set to "Data".

Trigger type dependent settings		
Condition	Pattern	
= Equal	[hex]0	
Position	Index min	Index max
[] In range	0	0

Condition ← Data conditions

Selects the operator for the "Data" pattern: "Equal" or "Not equal".

Remote command:

[TRIGger<m>:UART:FCONdition](#) on page 977

Pattern ← Data conditions

Specifies the data pattern to be found on the specified trigger source, in binary or hex format. Enter the words in msb first bit order. The starting point of the pattern is defined by [Position](#) and [Index min](#), [Index max](#).

The bit pattern editor helps you to enter the pattern, see [chapter 14.1.4, "Bit Pattern Editor"](#), on page 425.

Remote command:

[TRIGger<m>:UART:DATA](#) on page 977

Position ← Data conditions

Operator for the data position. You can defined an exact position, or a position range.

Remote command:

[TRIGger<m>:UART:DPOperator](#) on page 976

Index min, Index max ← Data conditions

Sets the number of words before the first word of interest. These offset words are ignored. If the [Position](#) defines a range, the first and the last word of interest are defined.

Remote command:

[TRIGger<m>:UART:DPOsition](#) on page 976

[TRIGger<m>:UART:DPTO](#) on page 977

14.4.4 UART Decode Results (Option R&S RTO-K2)

If the option is installed, the "Decode" function in the "Configuration" tab is available. Enable "Decode" to display the decoded signal below the waveforms.

Additionally, you can display the binary signal and the detailed decoding results, see [chapter 14.1.2, "Display"](#), on page 420.

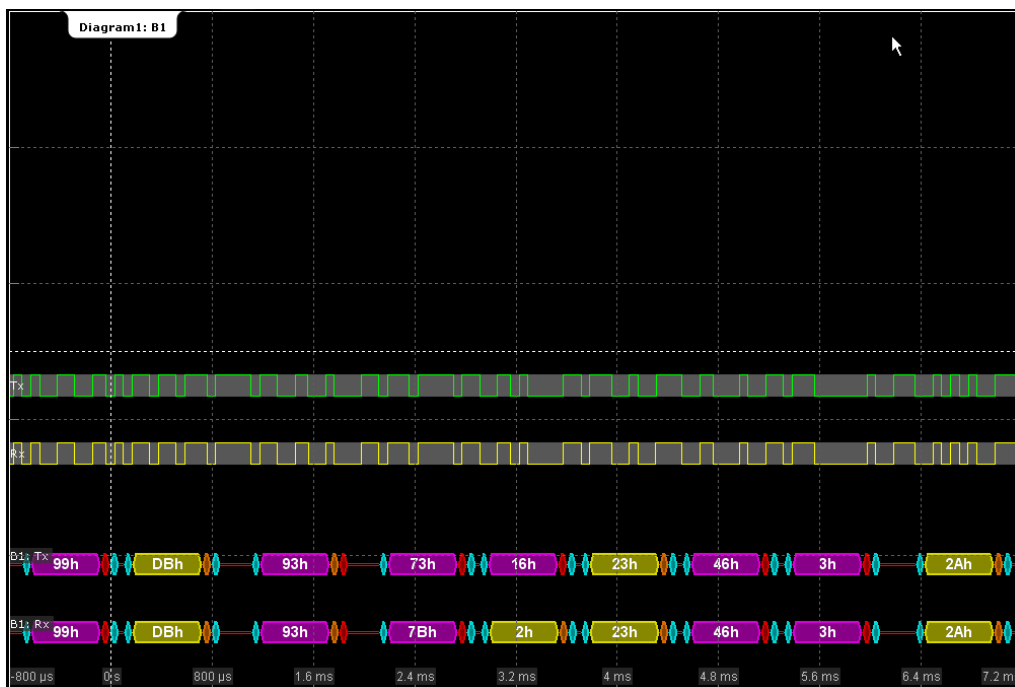

Fig. 14-10: Decoded and binary UART signal

- blue = start and stop bits if ok
- red = start error, stop error, parity error
- orange = parity bit if ok
- yellow = word ok
- magenta = word contains error

The "Decode results" box shows the detailed decoded data for each word.

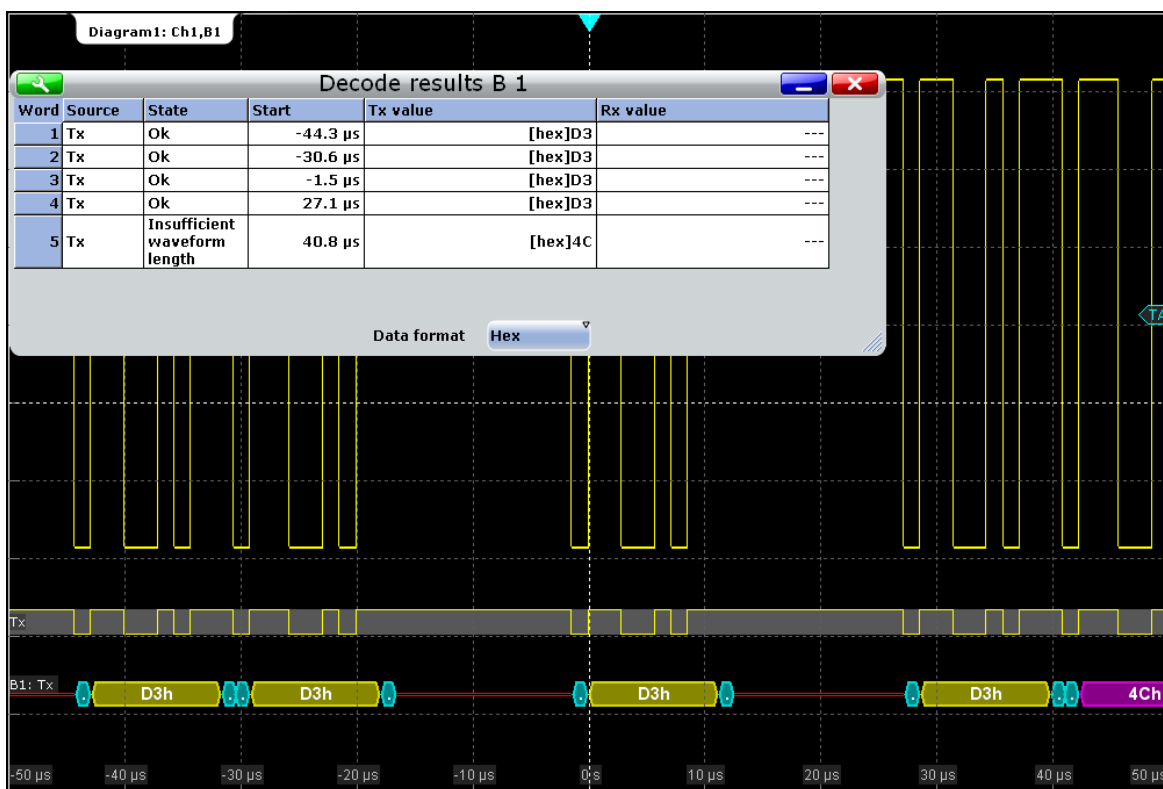

Fig. 14-11: Decode results of the UART signal

Table 14-3: Content of the "Decode results" table

Column	Description
Source	Line, Tx or Rx
State	Decoding state of the word. "Insufficient waveform length" indicates that the word is not completely contained in the acquisition. Change the horizontal scale, or move the reference point to the left to get a longer acquisition.
Start	Time of the word start (start bit)
Tx value	Value of the Tx word. The data format is selected below the table.
Rx value	Value of the Rx word. The data format is selected below the table.

SCPI commands:

- `BUS<m>:UART:WORD<n>:COUNT?` on page 978
- `BUS<m>:UART:WORD<n>:SOURCE?` on page 978
- `BUS<m>:UART:WORD<n>:STATE?` on page 979
- `BUS<m>:UART:WORD<n>:START?` on page 979
- `BUS<m>:UART:WORD<n>:TXVALUE?` on page 978
- `BUS<m>:UART:WORD<n>:RXVALUE?` on page 978

14.5 CAN (Option R&S RTO-K3)

CAN is the Controller Area Network, a bus system used within automotive network architecture.

14.5.1 CAN Configuration

Access: PROTOCOL > "Configuration" tab > "Protocol" = CAN



Make sure that the tab of the correct serial bus is selected on the left side.

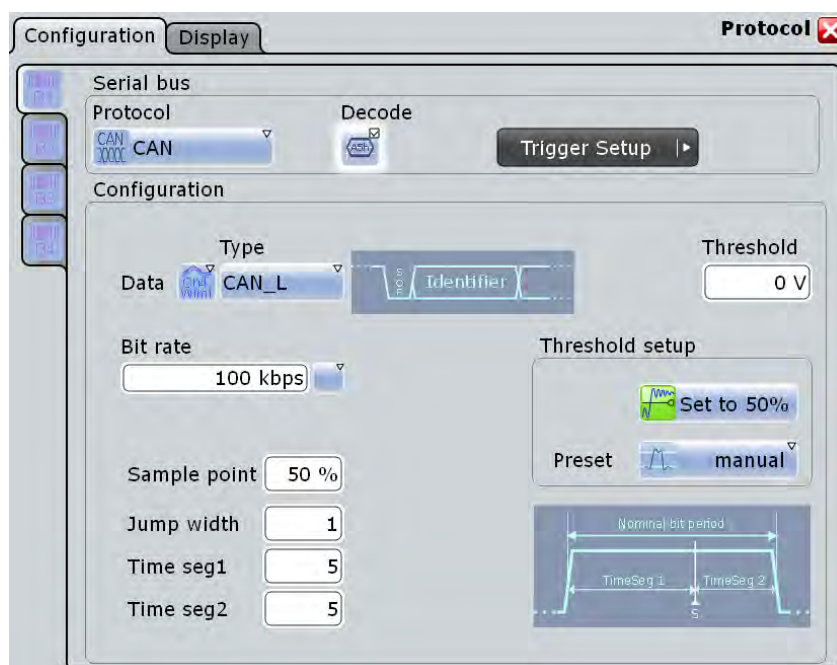

See also: [chapter 14.1.1, "Configuration - General Settings"](#), on page 420.

Data

Sets the source of the selected data line.

Alternatively, digital channels can be used if MSO option R&S RTO-B1 is installed. Digital and analog channels cannot be used at the same time.

For triggering on a serial bus, analog or digital input channels are required. Math and reference waveforms are not available.

Remote command:

`BUS<m>:CAN:DATA:SOURce` on page 980

Type

Selects the CAN-High or CAN-Low line. CAN uses both lines for differential signal transmission.

If you measure with a differential probe, connect the probe to both CAN-H and CAN-L lines, and select the data "Type" *CAN-H*.

If you use a single-ended probe, connect the probe to either CAN_L or CAN_H, and select the data type accordingly.

Remote command:

[BUS<m>:CAN:TYPE](#) on page 980

Threshold

Sets the threshold value for digitization of the signal. If the signal value on the line is higher than the threshold, the signal state is high (1 or true for the boolean logic). Otherwise, the signal state is considered low (0 or false).

There are three ways to set the threshold:

- "Threshold"
Enter the value directly in the field.
- "Set to 50%"
Executes the measurement of reference levels and sets the thresholds to the middle reference level of the measured amplitude.
- "Preset"
Selects the default threshold voltage for various signal technologies from a list. The value is set to "Manual" if the threshold was set with "Set to 50%", or was entered directly.

Note: If the sources are digital channels, the same threshold values are used for the parallel and the serial buses. You can set the thresholds either in the parallel bus configuration or in the serial bus configuration.

Remote command:

[BUS<m>:CAN:DATA:THReshold](#) on page 980

[BUS<m>:CAN:TECHnology](#) on page 981

[BUS<m>:SETRefllevels](#) on page 939

Bit rate

Sets the number of transmitted bits per second. The maximum bit rate for High Speed CAN is 1 Mbit/s. The bit rate is uniform and fixed for a given CAN bus.

To select a bit rate from the list of predefined values, tap the icon beside the "Bit rate" field. To enter a specific value, open the keypad. The list of predefined values is also available in the keypad.

Remote command:

[BUS<m>:CAN:BITRate](#) on page 981

Synchronization: Sample point, Time segments, Jump width

The CAN bus interface uses an asynchronous transmission scheme. The standard specifies a set of rules to resynchronize the local clock of a CAN node to the message.

The sample point divides the nominal bit period into two distinct time segments. The length of the time segments is defined in time quanta according to network and node conditions during CAN development.

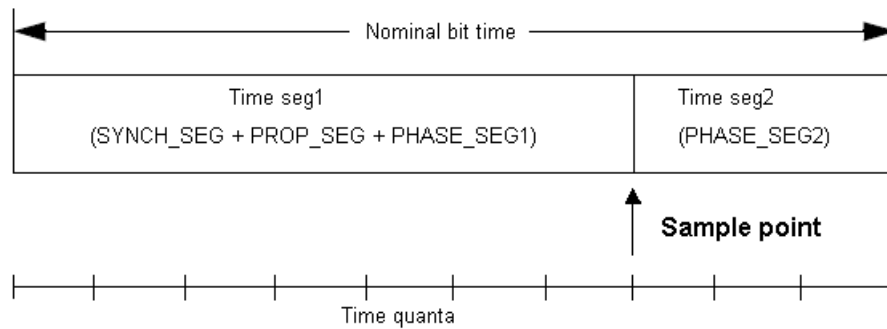

To specify the bit timing, enter either "Time seg1" and "Time seg2", or directly the "Sample point". Additionally, set the "Jump width".

- "Time seg1, Time seg2" Set the number of time quanta before the sample point (Time seg1) and after the sample point (Time seg2). The "Sample point" percentage value is adjusted accordingly. Time seg1 comprises the segments Synch_seg, Prop_seg, and Phase_seg1 which are specified in the CAN standard. Time seg2 matches Phase_seg2 from the standard. The maximum sum of Time seg1 and Time seg2 is 25.
- "Sample point" Sets the position of the sample point within the bit in percent of the nominal bit time. The time quanta values "Time seg1, Time seg2" are adjusted accordingly.
- "Jump width" Time segment1 may be lengthened or time segment2 may be shortened due to resynchronization. Resynchronization corrects the phase error of an edge caused by the drift of the oscillators. The jump width defines the maximum number of time quanta for phase correction. The maximum value of the jump width is 4, or $Time\ seg1 - Time\ seg2$ if this difference is lower than 4.

Remote command:

[BUS<m>:CAN:T1Segment](#) on page 982

[BUS<m>:CAN:T2Segment](#) on page 982

[BUS<m>:CAN:SAMPlepoint](#) on page 982

[BUS<m>:CAN:JWIDth](#) on page 982

14.5.2 CAN Trigger

Access: TRIGGER > "Source" = *Serial Bus* and "Protocol" = *CAN*

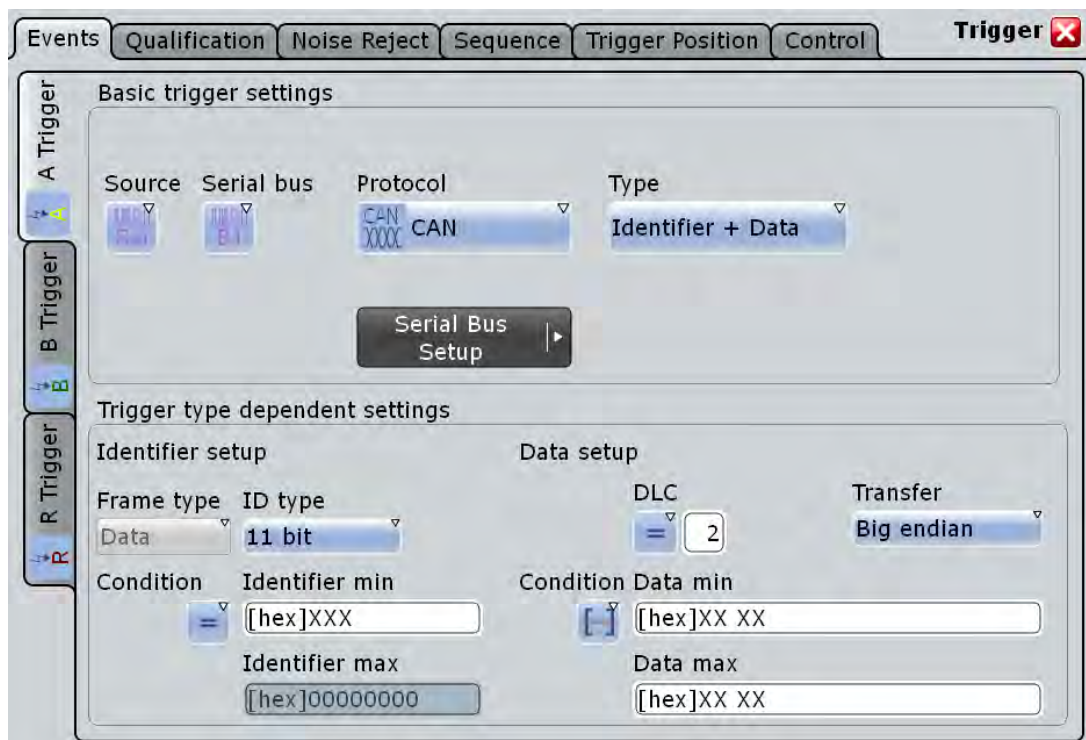

Make sure that:

- the trigger sequence is set to "A only"
- the trigger source is "Serial bus", and the data source(s) of the bus are channel signals
- the correct serial bus is selected
- the correct protocol is selected

Trigger type

Selects the trigger type for CAN analysis.

"Start of frame" Triggers on the first edge of the dominant SOF bit (synchronization bit).

"Frame type" Triggers on a specified frame type (data, remote, error, or overload). For data and remote frames, also the identifier format is considered.

For details, see:

- ["Frame type"](#) on page 461
- ["ID type"](#) on page 461

"Identifier" Sets the trigger to a specific message identifier or an identifier range. See ["Identifier setup: Condition, Identifier min, Identifier max"](#) on page 461.

"Identifier + Data" Sets the trigger to a combination of identifier and data condition. The instrument triggers at the end of the last byte of the specified data pattern.
The identifier conditions are the same as for the "Identifier" trigger type, see "Identifier setup: Condition, Identifier min, Identifier max" on page 461. Data conditions are set with "Data setup: DLC, Transfer, Condition, Data min, Data max" on page 462.

"Error condition" Identifies various errors in the frame, see "Error conditions: CRC, Bit stuffing, Form, Ack" on page 463.

Remote command:

TRIGger<m>:CAN:TYPE on page 983

Frame type

CAN has four frame types which can be used as trigger condition.

For data and remote frames, the identifier format has to be set with ID type.

"Data" The data frame is the only frame for actual data transmission.

"Remote" The remote frame initiates the transmission of data by another node. The frame format is the same as of data frames but without the data field.

"Error" When a node recognizes an error, it cancels transmission by sending an error frame.
The instrument triggers seven bit periods after the end of the error flag that is marked by a dominant-recessive edge.
The ID type is irrelevant for error frames.

"Overload" When a node needs a delay between data and/or remote frames, it sends an overload frame.
The instrument triggers seven bit periods after the end of the overload flag that is marked by a dominant-recessive edge.
The ID type is irrelevant for overload frames.

Remote command:

TRIGger<m>:CAN:FTYPE on page 984

ID type

Selects the length of the identifier:

"11 bit" Identifier length of the CAN base frame format. The instrument triggers on the sample point of the IDE bit.

"29 bit" Identifier length of the CAN extended frame format. The instrument triggers on the sample point of the RTR bit.

"Any" The ID type is not relevant. If the trigger type is "Identifier + Data", set the "ID type" to "Any" if you want to trigger only on data.

Remote command:

TRIGger<m>:CAN:ITYPe on page 985

Identifier setup: Condition, Identifier min, Identifier max

The identifier setup consists mainly of the condition and one or two identifier patterns. Additionally, ID type and frame type may qualify the identifier.

The trigger point depends on the ID type.

- "Frame type" Data frames and remote frames contain an identifier. Select the frame type to be triggered on, or select "Any" if the frame type is not relevant.
- "ID type" See: ["ID type"](#) on page 461.
- "Condition" Defines the operator to set a specific identifier ("Equal" or "Not equal") or an identifier range.
- "Identifier min" Defines the bit pattern of the message identifier. In binary format, use the following characters: 1; 0; or X (any bit). The use of X is restricted to the conditions "Equal" and "Not equal".
The length of the bit patterns is restricted to the selected "ID type".
The bit pattern editor helps you to enter the pattern in any format, see [chapter 14.1.4, "Bit Pattern Editor"](#), on page 425.
- "Identifier max" The second identifier pattern is required to specify a range with conditions "In range" and "Out of range".

Remote command:

[TRIGger<m>:CAN:ICONdition](#) on page 985

[TRIGger<m>:CAN:IMIN](#) on page 986

[TRIGger<m>:CAN:IMAX](#) on page 986

Data setup: DLC, Transfer, Condition, Data min, Data max

The data setup consists of the transfer direction, the number of bytes, the condition, and one or two data patterns.

To trigger only on data, set the "ID type" of the identifier setup to "Any".

- "Transfer" Sets the byte order (endianess) of the data transfer. With big endian, the most significant byte is transmitted first. The reverse order, least significant byte first, is called "Little endian".
- "DLC" Sets the Data Length Code, the number of data bytes to be found. For "Big Endian" transfer direction, you can trigger on a number of bytes less than the DLC of the frame, that means, on the beginning of the data pattern. For "Little Endian" transfer direction, the exact number of data bytes in the frame must be set.
Example: $DLC \geq 2$. The frame has at least two bytes, and you trigger on the data of the first two bytes.
- "Condition" Sets the operator to set a specific data pattern ("Equal" or "Not equal") or a data range.
- "Data min" Defines the data pattern. The pattern length is adjusted to the DLC setting (and vice versa), maximum is 8 bytes. Enter the pattern MSB first and with big endian byte order.
In binary format, use the following characters: 1; 0; or X (any bit). The bit pattern editor helps you to enter the pattern in any format, see [chapter 14.1.4, "Bit Pattern Editor"](#), on page 425.

"Data max" The second data pattern is required to specify a range with conditions "In range" and "Out of range".

Remote command:

[TRIGger<m>:CAN:BORDER](#) on page 987

[TRIGger<m>:CAN:DCONDITION](#) on page 986

[TRIGger<m>:CAN:DMIN](#) on page 986

[TRIGger<m>:CAN:DMAX](#) on page 987

[TRIGger<m>:CAN:DLCCONDITION](#) on page 987

[TRIGger<m>:CAN:DLC](#) on page 988

Error conditions: CRC, Bit stuffing, Form, Ack

If a CAN detects a bit stuffing error, form error, or ack error, it transmits an error flag at the next bit. The R&S RTO detects errors in the message and triggers on these errors even if no CAN node sends an error flag.

- CRC error
CAN uses the Cyclic Redundancy Check, which is a complex checksum calculation method. The transmitter calculates the CRC and sends the result in the CRC sequence. The receiver calculates the CRC in the same way. A CRC error occurs when the calculated result differs from the received value in the CRC sequence.
- Bit stuffing error
The frame segments Start Of Frame, Arbitration Field, Control Field, Data Field and CRC Sequence are coded by the bit stuffing method. The transmitter automatically inserts a complementary bit into the bit stream when it detects five consecutive bits of identical value in the bit stream to be transmitted. A stuff error occurs when the 6th consecutive equal bit level in the mentioned fields is detected.
- Form error
A form error occurs when a fixed-form bit field contains one or more illegal bits.
- Ack error
An acknowledgement error occurs when the transmitter does not receive an acknowledgment - a dominant bit during the Ack Slot.

Remote command:

[TRIGger<m>:CAN:CRCError](#) on page 989

[TRIGger<m>:CAN:BITSterror](#) on page 988

[TRIGger<m>:CAN:FORMerror](#) on page 989

[TRIGger<m>:CAN:ACKerror](#) on page 988

14.5.3 CAN Label List

Label lists are protocol-specific. A PTT file for CAN contains three values for each identifier:

- "Type": identifier type, 11-bit or 29-bit long
- "ID / Addr": hexadecimal identifier value
- "Symbolic label": symbolic name of the identifier, specifying its function in the bus network.

Example: CAN PTT file

```

# -----
@FILE_VERSION = 1.00
@PROTOCOL_NAME = can
# -----
# Labels for CAN protocol
# Column order: Identifier type, Identifier value, Label
# -----
11,0x064,Diag_Response
11,0x1E5,EngineData
11,0x0A2,Ignition_Info
11,0x1BC,TP_Console
11,0x333,ABSdata
11,0x313,Door_Left
11,0x314,Door_Right
29,0x01A54321,Throttle
29,0x13A00FA2,LightState
29,0x0630ABCD,Engine_Status
29,0x03B1C002,Airbag_Status
29,0x01234ABC,NM_Gateway
# -----

```

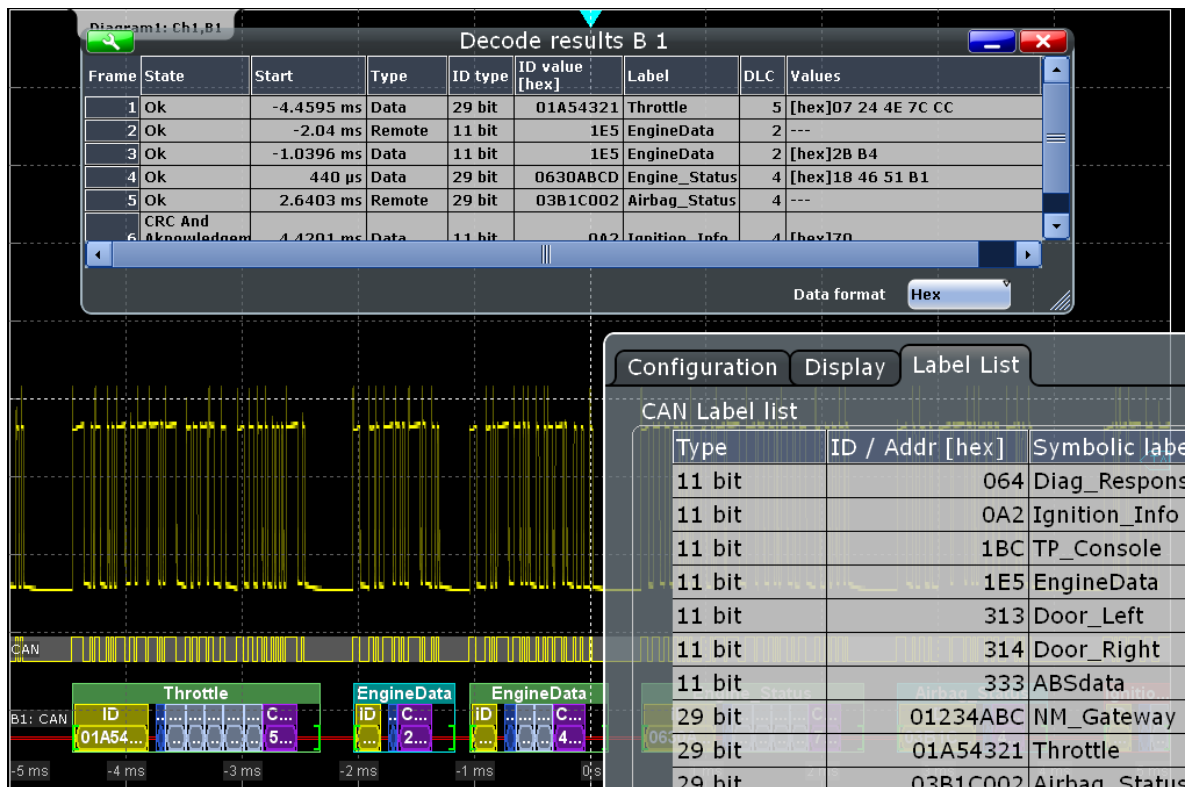

For general information on the "Label List" tab, see [chapter 14.1.3, "Label Lists"](#), on page 422.

SCPI command

- `BUS<m>:CAN:FRAME<n>:SYMBOL?` on page 995

14.5.4 CAN Decode Results

To display the decoded signal below the waveforms, enable "Decode" on the "Configuration" tab.

Additionally, you can display the binary signal and the detailed decoding results using the setting on the "Display" tab, see [chapter 14.1.2, "Display"](#), on page 420.

Data is decoded and displayed in the order of its reception. The endianness setting is not considered for decoding. The "Decode results" box shows the detailed decoded data for each frame as it is received.

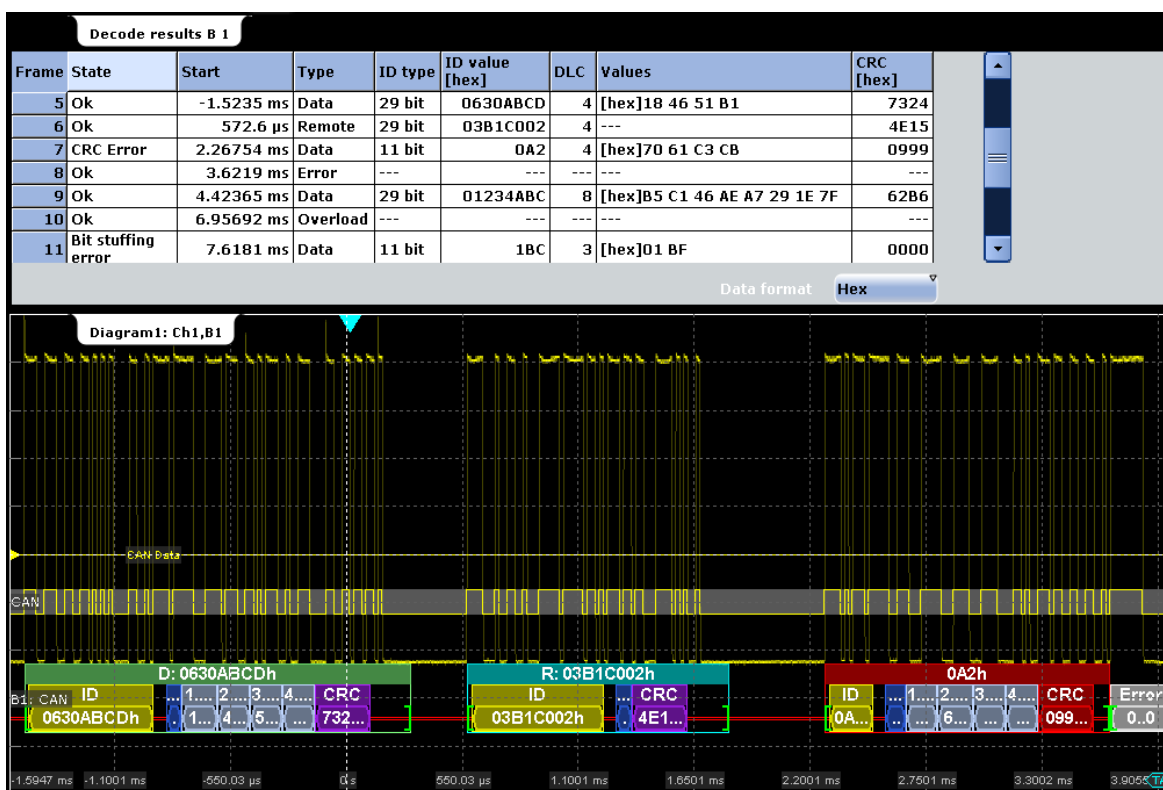

Fig. 14-12: Decoded and binary CAN signal, and decode results

- green brackets [...] = Start and end of frame
- green frame header = Data frame, ok
- cyan frame header = Remote frame, ok
- magenta frame header = Overload frame, ok
- red frame header = Frame contains an error
- no frame header = Error frame
- yellow = Identifier
- blue = DLC
- gray-blue = data
- purple = CRC (checksum)
- gray = Error frame
- red = Error occurred

Table 14-4: Content of the "Decode results" table

Column	Description
State	Overall state of the frame. "Insufficient waveform length" indicates that the frame is not completely contained in the acquisition. Change the horizontal scale, or move the reference point to the left to get a longer acquisition.
Start	Time of frame start
Type	Frame type: Data, Remote, Error, or Overload
ID type	11 bit standard format or 29 bit extended format
ID value (hex)	Identifier value, hexadecimal value
DLC	Data length code, number of data bytes
Values	Value of the data bytes. The data format is selected below the table. Remote frames do not transmit data, therefore "- -" is displayed.
CRC (hex)	Value of the Cyclic Redundance Check (checksum), hexadecimal value

SCPI commands:

- [BUS<m>:CAN:FCOunt?](#) on page 990
- [BUS<m>:CAN:FRAMe<n>:STATus?](#) on page 990
- [BUS<m>:CAN:FRAMe<n>:DATA?](#) on page 991
- [BUS<m>:CAN:FRAMe<n>:STARt?](#) on page 990
- [BUS<m>:CAN:FRAMe<n>:STOP?](#) on page 990
- [BUS<m>:CAN:FRAMe<n>:TYPE?](#) on page 991
- [BUS<m>:CAN:FRAMe<n>:ACKState?](#) on page 991
- [BUS<m>:CAN:FRAMe<n>:ACKValue?](#) on page 992
- [BUS<m>:CAN:FRAMe<n>:BSEPosition?](#) on page 994
- [BUS<m>:CAN:FRAMe<n>:BYTE<o>:STATe?](#) on page 994
- [BUS<m>:CAN:FRAMe<n>:BYTE<o>:VALue?](#) on page 995
- [BUS<m>:CAN:FRAMe<n>:CSState?](#) on page 991
- [BUS<m>:CAN:FRAMe<n>:CSValue?](#) on page 992
- [BUS<m>:CAN:FRAMe<n>:DLCState?](#) on page 991
- [BUS<m>:CAN:FRAMe<n>:DLCValue?](#) on page 993
- [BUS<m>:CAN:FRAMe<n>:IDState?](#) on page 991
- [BUS<m>:CAN:FRAMe<n>:IDTYpe?](#) on page 993
- [BUS<m>:CAN:FRAMe<n>:IDValue?](#) on page 993

14.6 LIN (Option R&S RTO-K3)

The Local Interconnect Network (LIN) is a simple, low-cost bus system used within automotive network architectures. LIN is usually a sub-network of a CAN bus. The primary purpose of LIN is the integration of uncritical sensors and actuators with low bandwidth requirements. Common applications in a motor vehicle are the control of doors, windows, wing mirrors, and wipers.

14.6.1 The LIN Protocol

This chapter provides an overview of protocol characteristics, frame format, identifiers and trigger possibilities. For detailed information, order the LIN specification on <http://www.lin-subbus.org/> (free of charge).

LIN characteristics

Main characteristics of LIN are:

- Single-wire serial communications protocol, based on the UART byte-word interface
- Single master, multiple slaves - usually up to 12 nodes
- Master-controlled communication: master coordinates communication with the LIN schedule and sends identifier to the slaves
- Synchronization mechanism for clock recovery by slave nodes without crystal or ceramics resonator

The R&S RTO supports several versions of the LIN standard: v1.3, v2.0, v2.1 and the american SAE J2602.

Data transfer

Basic communication concept of LIN:

- Communication in an active LIN network is always initiated by the master.
- Master sends a message header including the synchronization break, the synchronization byte, and the message identifier.
- The identified node sends the message response: one to eight data bytes and one checksum byte.
- Header and response form the message frame.

The data is transmitted in bytes using the UART byte-word interface without the parity bit. Each byte consists of a start bit, 8 bits and a stop bit.

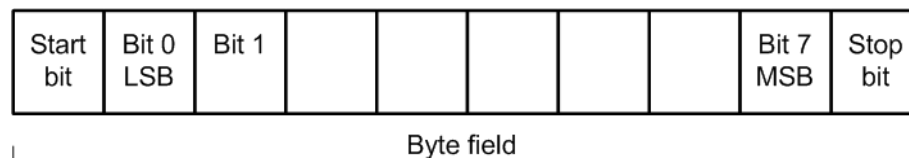

Fig. 14-13: Structure of a byte field

Data bytes are transmitted LSB first.

The identifier byte consists of 6 bits for the frame identifier and two parity bits. This combination is known as protected identifier.

Trigger

The R&S RTO can trigger on various parts of LIN frames. The data line must be connected to an input channel, triggering on math and reference waveforms is not possible.

You can trigger on:

- Frame start (synchronization field)
- Specific slave identifier or identifier range
- Data pattern in the message
- Wake up signal
- Checksum error (error in data), parity error (error in identifier)

14.6.2 LIN Configuration

Access: PROTOCOL > "Configuration" tab > "Protocol" = LIN



Make sure that the tab of the correct serial bus is selected on the left side.

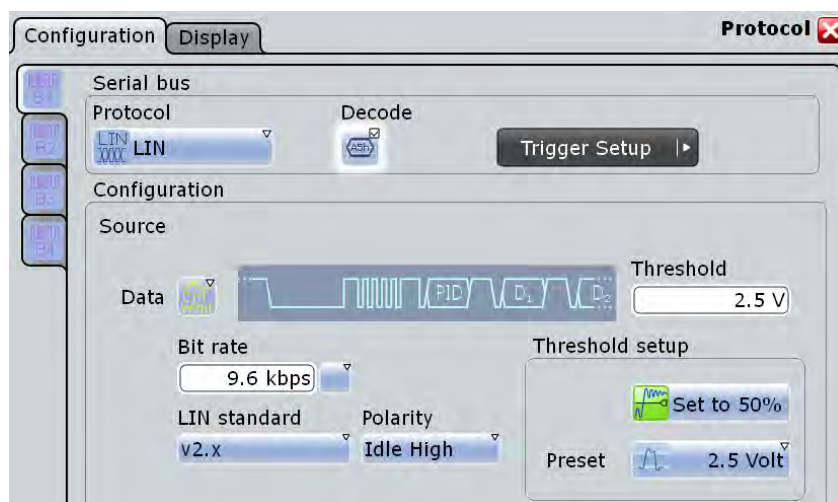

See also: [chapter 14.1.1, "Configuration - General Settings"](#), on page 420.

Data

Sets the source waveform of the data line.

Alternatively, digital channels can be used if MSO option R&S RTO-B1 is installed. Digital and analog channels cannot be used at the same time.

For triggering on a serial bus, analog or digital input channels are required. Math and reference waveforms are not available.

Remote command:

[BUS<m>:LIN:DATA:SOURce](#) on page 996

Threshold

Sets the threshold value for digitization of the signal. If the signal value on the line is higher than the threshold, the signal state is high. Otherwise, the signal state is considered low if the signal value is below the threshold. The interpretation of HIGH and LOW is defined by the [Polarity](#).

There are three ways to set the threshold:

- "Threshold"
Enter the value directly in the field.
- "Set to 50%"
Executes the measurement of reference levels and sets the thresholds to the middle reference level of the measured amplitude.
- "Preset"
Selects the default threshold voltage for various signal technologies from a list. The value is set to "Manual" if the threshold was set with "Set to 50%", or was entered directly.

Note: If the sources are digital channels, the same threshold values are used for the parallel and the serial buses. You can set the thresholds either in the parallel bus configuration or in the serial bus configuration.

Remote command:

[BUS<m>:LIN:DATA:THReshold](#) on page 996

[BUS<m>:LIN:TECHnology](#) on page 997

[BUS<m>:SETReflevels](#) on page 939

Bit rate

Sets the number of transmitted bits per second. The maximum bit rate for LIN is 20 kbit/s.

To select a bit rate from list of predefined values, tap the icon beside the "Bit rate" field. To enter a specific value, open the keypad. The list of predefined values is also available in the keypad.

If the "LIN standard" is "J2602", the bit rate is 10417 kbit/s and cannot be changed.

Remote command:

[BUS<m>:LIN:BITRate](#) on page 997

LIN standard

Selects the version of the LIN standard that is used in the DUT. The setting mainly defines the checksum version used during decoding.

The most common version is LIN 2.x. For mixed networks, or if the standard is unknown, set the LIN standard to "Auto".

Remote command:

[BUS<m>:LIN:STANdard](#) on page 998

Polarity

Defines the idle state of the bus. The idle state is the recessive state and corresponds to a logic 1.

Remote command:

[BUS<m>:LIN:POLarity](#) on page 998

14.6.3 LIN Trigger

Access: TRIGGER > "Source" = *Serial Bus* and "Protocol" = *LIN*

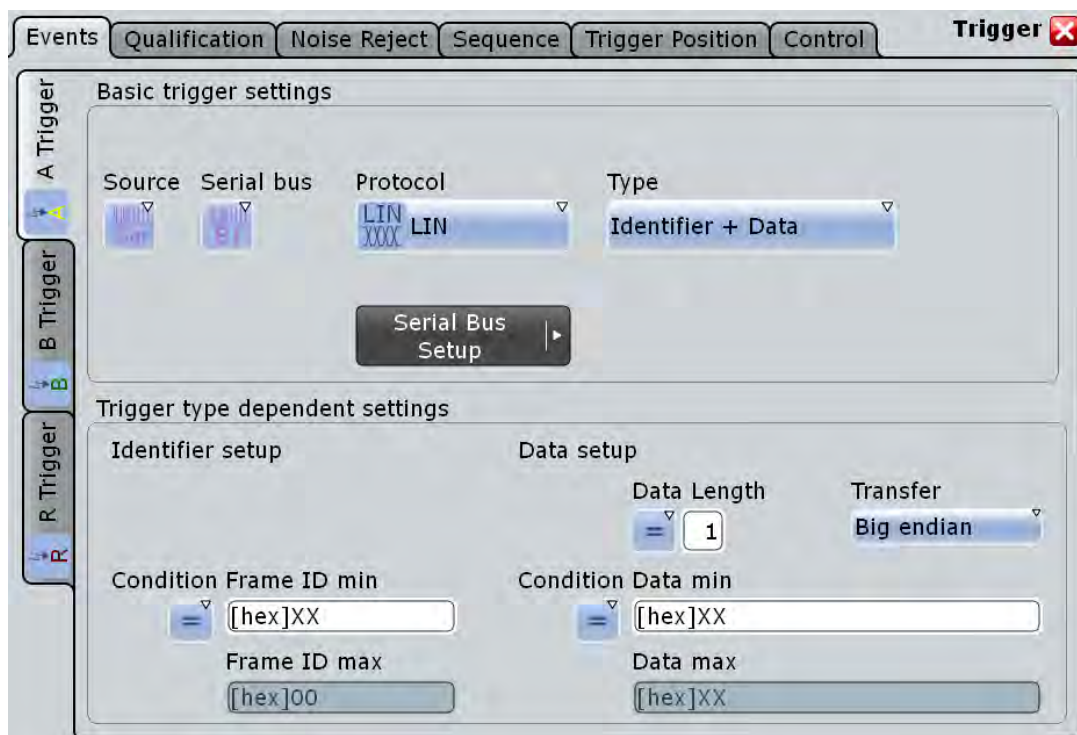

Make sure that:

- the trigger sequence is set to "A only"
- the trigger source is "Serial bus", and the data source(s) of the bus are channel signals
- the correct serial bus is selected
- the correct protocol is selected

Trigger type

Selects the trigger type for LIN analysis.

"Start of frame (Sync) Triggers on the stop bit of the sync field."



"Identifier"	Sets the trigger to one specific identifier or an identifier range. Enter only the 6 bit identifier without parity bits, not the protected identifier. Description of trigger type specific settings: " Identifier setup: Condition, Frame ID min, Frame ID max " on page 471.
"Identifier OR"	Sets the trigger to a combination of up to four identifiers. Description of trigger type specific settings: " Identifier OR setup: Monitor, Frame ID " on page 471
"Identifier + Data"	Sets the trigger to a combination of identifier and data condition. The instrument triggers at the end of the last byte of the specified data pattern. The identifier conditions are the same as for the "Identifier" trigger type, see Identifier setup: Condition, Frame ID min, Frame ID max . Data conditions are set with Data setup: Data length, Transfer, Condition, Data min, Data max .
"Wakeup frame"	Triggers after a wakeup frame.
"Error condition"	Identifies various errors in the frame, see " Error conditions " on page 473.

Remote command:

[TRIGger<m>:LIN:TYPE](#) on page 998

Identifier setup: Condition, Frame ID min, Frame ID max

The identifier setup consists of the condition and one or two identifier pattern.

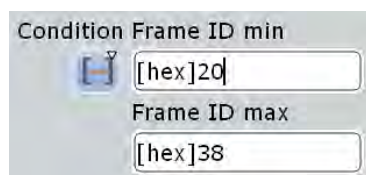

"Condition"	Defines the operator to set a specific identifier ("Equal" or "Not equal") or an identifier range.
"Frame ID min / Frame ID"	Defines the bit pattern of the slave identifier. Enter only the 6 bit identifier without parity bits, not the protected identifier. In binary format, use the following characters: 1; 0; or X (don't care). The bit pattern editor helps you to enter the pattern in any format, see chapter 14.1.4, "Bit Pattern Editor" , on page 425.
"Frame ID max"	The second identifier pattern is required to specify a range with conditions "In range" and "Out of range".

Remote command:

[TRIGger<m>:LIN:ICONdition](#) on page 999

[TRIGger<m>:LIN:IMIN](#) on page 1000

[TRIGger<m>:LIN:IMAX](#) on page 1000

Identifier OR setup: Monitor, Frame ID

Sets the trigger to a combination of up to four identifiers. Enter the patterns in the "Frame ID" fields. In binary and hex format, characters 1, 0, and X (don't care) are allowed. For each identifier pattern to be triggered on, enable "Monitor".



Remote command:

[TRIGger<m>:LIN:IDOR<n>:ENABle](#) on page 1003

[TRIGger<m>:LIN:IDOR<n>\[:VALue\]](#) on page 1003

Data setup: Data length, Transfer, Condition, Data min, Data max

The data setup consists of the transfer direction, the number of bytes, the condition, and one or two data patterns.

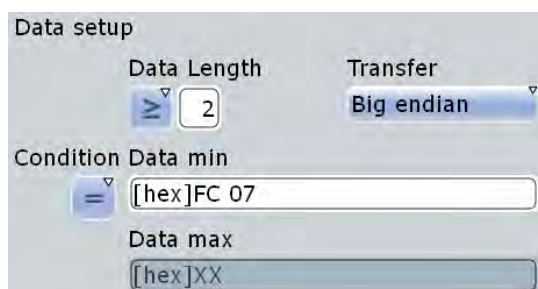

- "Transfer" Sets the byte order (endianess) of the data transfer. With "Big endian", the data is analyzed and evaluated in the order of reception. With "Little endian", the instrument reads the complete data and then compares it with the data pattern in reverse order. According to the standard, LIN data is transmitted in little endian transfer order.
- "Data length" Sets the length of the bit pattern to be found, in bytes. For "Big Endian" transfer direction, you can trigger on a number of bytes less than the data length of the frame, that means, on the beginning of the data pattern. For "Little Endian" transfer direction, the exact number of data bytes in the frame must be set.
Example: Data length \geq 2 and Transfer = Big endian. The frame has at least two bytes, and you trigger on the data of the first two bytes.
- "Condition" Sets the operator to set a specific data pattern ("Equal" or "Not equal") or an data range.
- "Data min" Defines the data pattern. The pattern length is adjusted to the data length setting (and vice versa), maximum is 8 bytes. Enter the pattern MSB first and with big endian byte order. The data is compared byte by byte.
In binary format, use the following characters: 1; 0; or X (don't care). The use of X is restricted to the operators "Equal" and "Not equal".

"Data max" The second data pattern is required to specify a range with conditions "In range" and "Out of range".

Remote command:

[TRIGger<m>:LIN:BORDER](#) on page 1001

[TRIGger<m>:LIN:DLECondition](#) on page 1002

[TRIGger<m>:LIN:DLEnGth](#) on page 1002

[TRIGger<m>:LIN:DCONdition](#) on page 1000

[TRIGger<m>:LIN:DMIN](#) on page 1001

[TRIGger<m>:LIN:DMAX](#) on page 1001

Error conditions

Triggers if one or more of the following errors occur:

- Checksum error
The checksum verifies the correct data transmission. It is the last byte of the frame response. The checksum includes not only the data but also the protected identifier (PID). To identify checksum errors caused by data, additional settings are required: Enter the bit pattern of the slave identifier ("Frame ID"), the number of data bytes ("Data length"), and select the used "LIN standard". See also: "[LIN standard](#)" on page 469.
- Identifier parity error
Parity bits are the bits 6 and 7 of the identifier. They verify the correct transmission of the identifier.
- Sync error
Synchronization error

	Frame ID	Data length	LIN standard
<input checked="" type="checkbox"/> Checksum error	<input type="text" value="[hex]20"/>	<input type="text" value="0"/>	Auto
<input checked="" type="checkbox"/> Identifier parity error			
<input checked="" type="checkbox"/> Sync error			

Remote command:

[TRIGger<m>:LIN:CHKSError](#) on page 1004

[TRIGger<m>:LIN:ERRPattern](#) on page 1004

[TRIGger<m>:LIN:CRCDatalen](#) on page 1005

[TRIGger<m>:LIN:STANdard](#) on page 1005

[TRIGger<m>:LIN:IPERror](#) on page 1004

[TRIGger<m>:LIN:SYERror](#) on page 1003

14.6.4 LIN Label List

Label lists are protocol-specific. A LIN PTT file contains two values for each identifier:

- "ID / Addr": hexadecimal identifier value
- "Symbolic label": symbolic name for the identifier

Example: LIN PTT file

```

# -----
@FILE_VERSION = 1.0
@PROTOCOL_NAME = lin
# -----
# Labels for LIN protocol
# Column order: Identifier, Label
# -----
# Labels for standard addresses
0x06,Dashboard
0x13,Gateway
0x1C,Temperature
0x21,Mirror
0x37,Indoor lights
# Labels for reserved addresses
0x3C,Master_Request_Frame
0x3D,Slave_Response_Frame
# -----

```

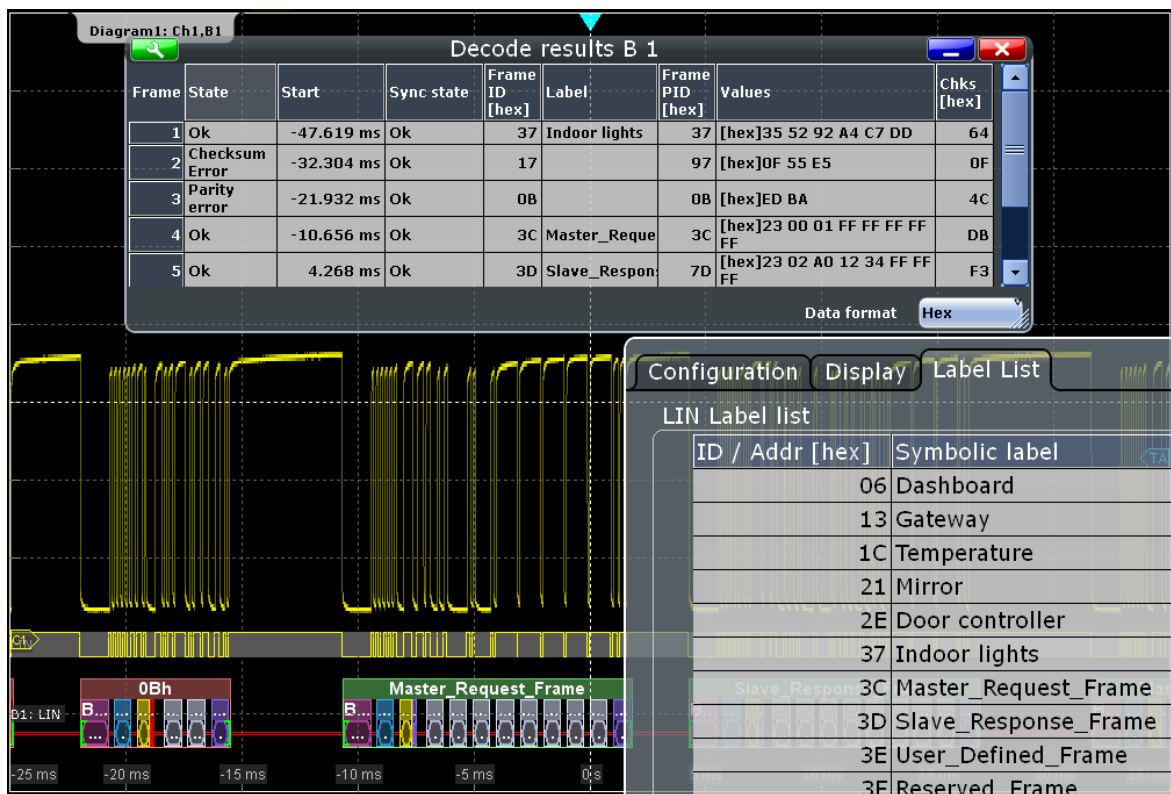

For general information on the "Label List" tab, see [chapter 14.1.3, "Label Lists"](#), on page 422.

SCPI command

- `BUS<m>:LIN:FRAME<n>:SYMBOL?` on page 1011

14.6.5 LIN Decode Results

To display the decoded signal below the waveforms, enable "Decode" on the "Configuration" tab.

Additionally, you can display the binary signal and the detailed decoding results using the setting on the "Display" tab, see [chapter 14.1.2, "Display"](#), on page 420.

Data is decoded and displayed in the order of its reception. The endianness setting is not considered for decoding. The "Decode results" box shows the detailed decoded data for each frame as it is received.

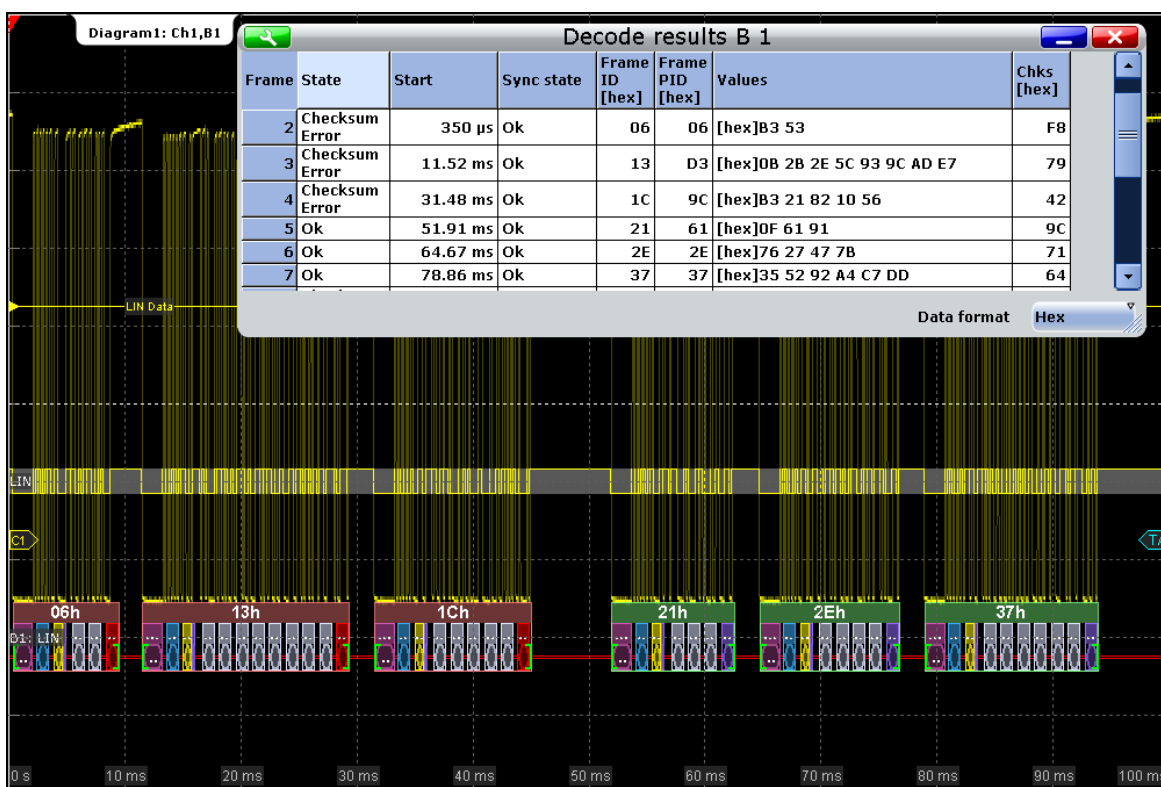

Fig. 14-14: Decoded and binary LIN signal, and decode results

- green brackets [...] = start and end of frame
- green frame header = frame state is ok
- red frame header = error in frame
- magenta frame header = wakeup frame
- magenta = break
- blue = sync
- yellow = frame ID ok
- grey = data bytes
- purple = parity bit, or checksum ok
- red = error in frame ID, or checksum, or parity bit

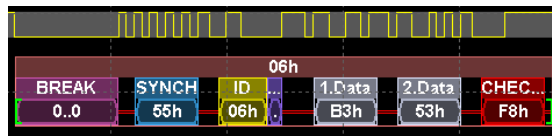

Fig. 14-15: Decoded frame with checksum error (frame No 1 in figure above)

Table 14-5: Content of the "Decode results" table

Column	Description
State	Overall state of the frame.
Start	Time of frame start
Sync state	Result of synchronization
Frame ID (hex)	Identifier value
Frame PID (hex)	Protected identifier
Values	Value of the data bytes. The data format is selected below the table.
Chks (hex)	Checksum value

SCPI commands:

- [BUS<m>:LIN:FCOunt?](#) on page 1005
- [BUS<m>:LIN:FRAMe<n>:STATus?](#) on page 1006
- [BUS<m>:LIN:FRAMe<n>:STARt?](#) on page 1006
- [BUS<m>:LIN:FRAMe<n>:STOP?](#) on page 1006
- [BUS<m>:LIN:FRAMe<n>:VERSion?](#) on page 1007
- [BUS<m>:LIN:FRAMe<n>:SYSTate?](#) on page 1009
- [BUS<m>:LIN:FRAMe<n>:IDSTate?](#) on page 1007
- [BUS<m>:LIN:FRAMe<n>:IDValue?](#) on page 1008
- [BUS<m>:LIN:FRAMe<n>:CSSTate?](#) on page 1009
- [BUS<m>:LIN:FRAMe<n>:CSValue?](#) on page 1009
- [BUS<m>:LIN:FRAMe<n>:IDPValue?](#) on page 1008
- [BUS<m>:LIN:FRAMe<n>:DATA?](#) on page 1007
- [BUS<m>:LIN:FRAMe<n>:BYTE<o>:STATe?](#) on page 1010
- [BUS<m>:LIN:FRAMe<n>:BYTE<o>:VALue?](#) on page 1010

14.7 FlexRay (Option R&S RTO-K4)

FlexRay is designed for use in safety-related distributed applications in the automotive industry. It is applied in real-time applications when higher data rates and reliable communication are required. In particular, FlexRay supports x-by-wire applications, for example, steer-by-wire or brake-by-wire.

14.7.1 FlexRay Configuration

Access: PROTOCOL > "Configuration" tab > "Protocol" = *FlexRay*



Make sure that the tab of the correct serial bus is selected on the left side.

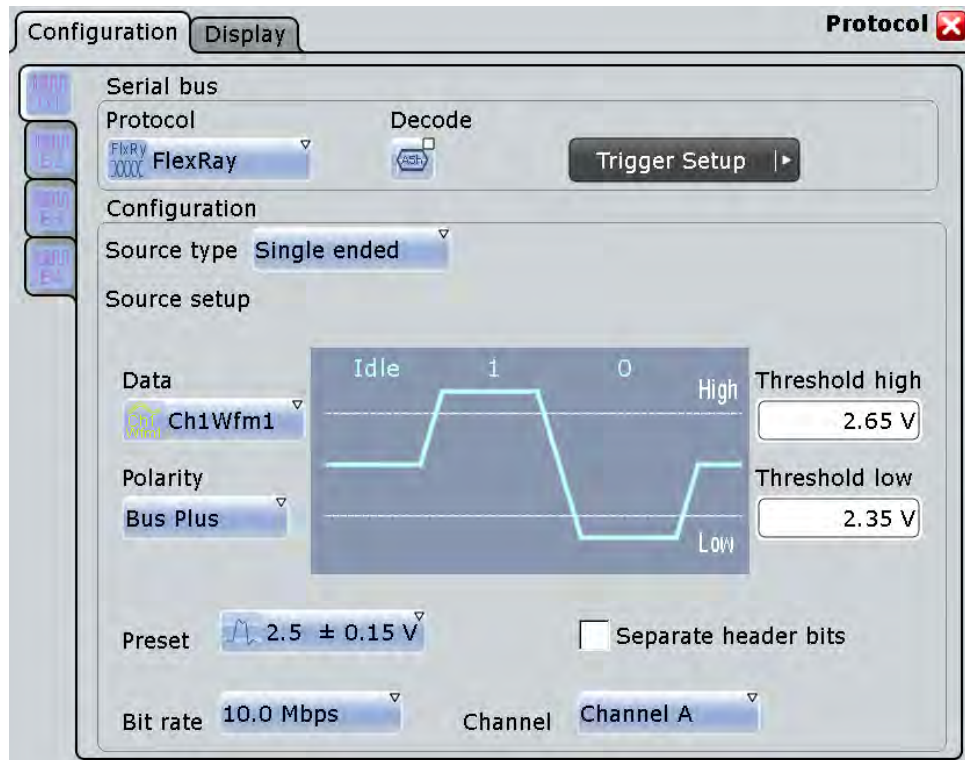

See also: [chapter 14.1.1, "Configuration - General Settings"](#), on page 420.

Source type

Sets the type of measurement. The instrument adjusts the thresholds to the selected source type.

- "Single-ended" For measurements with single-ended probes, or single-ended voltage measurements with differential probes on the FlexRay bus. Two thresholds have to be defined as absolute voltage levels.
- "Differential" For differential measurements on the FlexRay bus. This is the most common measurement. Two thresholds have to be defined as differential voltages.

"Logic" For measurements of logic signals, for example, of the logic signal inside the FlexRay node, between the communication controller and the bus driver. If MSO option R&S RTO-B1 is installed, you can use digital input channels. It is possible to measure simultaneously on a data line and on the enable line. Each line requires its own threshold.

Remote command:

[BUS<m>:FLXRay:SRCType](#) on page 1012

Data

Sets the input channel of the bus signal, or of the data line in case of a "Logic" source type. Waveform 1 of channel signals can be used. Reference and math waveforms are only available if the trigger source is one of the input channels but not the serial bus.

Alternatively to analog channels, digital channels can be used if MSO option R&S RTO-B1 is installed. Digital and analog channels cannot be used at the same time in a bus.

Remote command:

[BUS<m>:FLXRay:SOURce<n>](#) on page 1013

Enable

Sets the input channel of the enable line in case of a "Logic" source type. The enable line transfers the control signal of the bus guardian to the bus driver. None, or waveform 1 of channel signals can be used. Reference and math waveforms are only available if the trigger source is one of the input channels but not the serial bus.

Alternatively to analog channels, digital channels can be used if MSO option R&S RTO-B1 is installed. Digital and analog channels cannot be used at the same time in a bus.

Remote command:

[BUS<m>:FLXRay:SOURce<n>](#) on page 1013

Thresholds

Threshold values are used for digitization of the signal.

For measurements on a FlexRay bus, two thresholds are required to distinguish the three possible states of the signal - high, low and idle. If the signal value on the line is higher than the upper threshold, the signal state is high. Otherwise, the signal state is considered low if the signal value is below the lower threshold. If the value is between the threshold, the signal is in idle state.

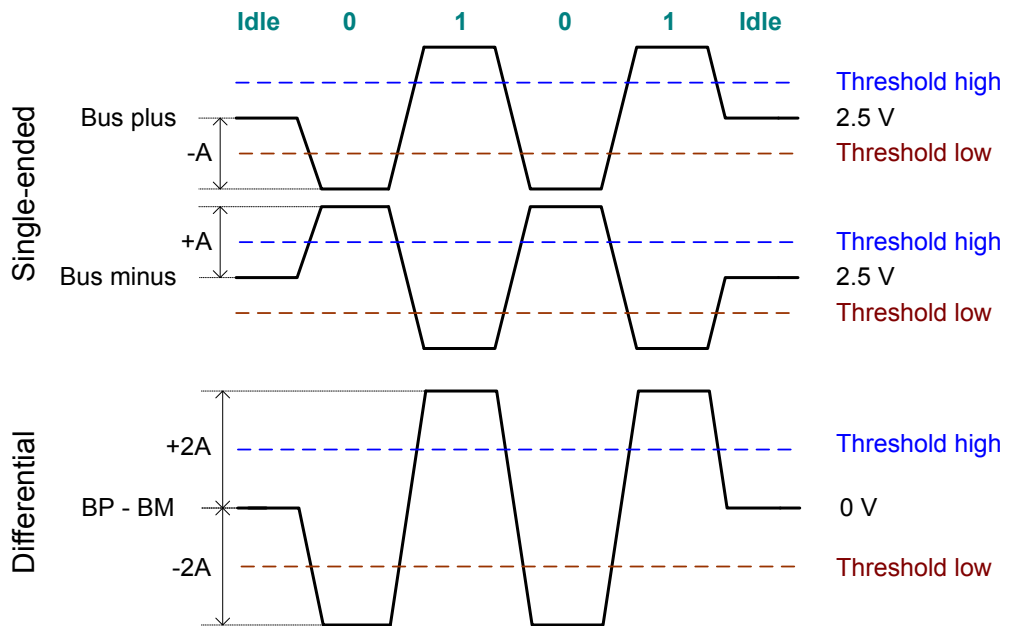

For measurements inside the FlexRay node (with "Source type" = "Logic"), each line requires its threshold level.

There are two ways to set the thresholds: selection of a predefined value, or direct entry of a value.

- "Preset"
Selects default threshold voltages from a list. The predefined values depend on the selected source type. The value is set to "Manual" if at least one threshold was entered directly.
- "Threshold high" and "Threshold low"
Upper and lower levels for single-ended or differential source types. You can enter the values directly in the fields.
- "Threshold data" and "Threshold enable"
Levels for data and enable line in case of logic source type. You can enter the values directly in the fields.

Note: If the sources are digital channels, the same threshold values are used for the parallel and the serial buses. You can set the thresholds either in the parallel bus configuration or in the serial bus configuration.

Remote command:

[BUS<m>:FLXRay:PRSingle](#) on page 1014

[BUS<m>:FLXRay:PRDiff](#) on page 1014

[BUS<m>:FLXRay:PRLogic](#) on page 1015

[BUS<m>:FLXRay:THReshold<n>](#) on page 1013

[BUS<m>:FLXRay:THData](#) on page 1014

[BUS<m>:FLXRay:THENable](#) on page 1013

[BUS<m>:SETReflevels](#) on page 939

Polarity

Selects the wire on which the bus signal is measured in case of "Single-ended" measurement: "Bus plus" or "Bus minus". The setting affects the digitization of the signal.

Remote command:

[BUS<m>:FLXRay:POLarity](#) on page 1015

Bit rate

Selects the number of transmitted bits per second from a list.

Remote command:

[BUS<m>:FLXRay:BITRate](#) on page 1015

Channel

Selects the FlexRay channel on which the signal is measured, either channel A or channel B. The setting is considered in the calculation of the frame CRC.

Remote command:

[BUS<m>:FLXRay:CHTYpe](#) on page 1016

Separate header bits

The setting affects the decoding and its display. If enabled, the leading five indicator bits of the header are decoded as five single bits. Otherwise, the indicator bits are shown as one word with word length five bits.

Remote command:

[BUS<m>:FLXRay:SEHB](#) on page 1016

14.7.2 FlexRay Trigger

Access: TRIGGER > "Source" = *Serial Bus* and "Protocol" = *FlexRay*

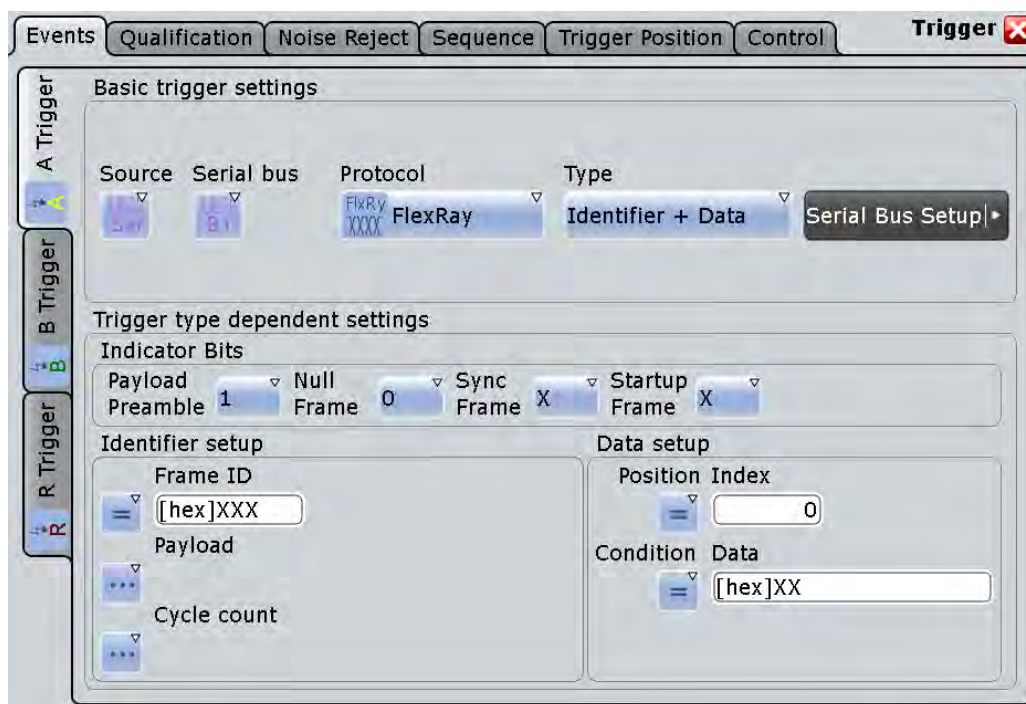

Make sure that:

- the trigger sequence is set to "A only"
- the trigger source is "Serial bus", and the data source(s) of the bus are channel signals
- the correct serial bus is selected
- the correct protocol is selected

Trigger type

Selects the trigger type for FlexRay analysis.

"Start of frame" Triggers on the first rising edge after the transmission start sequence (TSS).

"Identifier + data" Triggers on the decoded frame content, on header and payload data:

- Indicator bits, see ["Indicator bits"](#) on page 482
- Frame identifier, see ["Frame ID \(min/max\)"](#) on page 482
- Payload length, see ["Payload length \(min/max\)"](#) on page 483
- Cycle count, see ["Cycle count \(min, max\), Step"](#) on page 483
- Data position, see ["Position, Index \(min, max\) - Data setup"](#) on page 484
- Data bit pattern, see ["Condition, Data \(min, max\) - Data setup"](#) on page 484

"Symbol" Triggers on a symbol or wakeup pattern, see ["Symbol"](#) on page 484.

"Error condition" Triggers on one or more errors that are detected in the decoded data, see "Error conditions" on page 485.

Remote command:

[TRIGger<m>:FLXRay:TYPE](#) on page 1017

Indicator bits

Triggers on one or more indicator bits at the beginning of the header segment. Each bit can be set to 0, 1, or X (don't care).

Trigger type: "Identifier + data"

Reserved bit	Payload preamble	Null frame	Sync frame	Startup frame	Frame ID	Payload length	Header CRC	Cycle count	Payload	Trailer
Indicators 5 bits										

"Payload preamble" Indicates a Network Management Vector in the payload segment. The NMV allows the host processor to send data directly, without processing by the communication controller.

"Null frame" Indicates a frame without usable data.

"Sync frame" Indicates that the frame is used for synchronization of the FlexRay system. Only sync nodes can send this frame type.

"Startup frame" Indicates a startup frame used for startup of the network. Only specific start nodes can send this frame type.

Remote command:

[TRIGger<m>:FLXRay:PLPreamble](#) on page 1018

[TRIGger<m>:FLXRay:NUFframe](#) on page 1019

[TRIGger<m>:FLXRay:SYFframe](#) on page 1019

[TRIGger<m>:FLXRay:STFframe](#) on page 1019

Frame ID (min/max)

The frame ID contains the number of the slot in which the frame is transmitted. Each frame ID occurs only once during a FlexRay cycle.

Indicators	Frame ID	Payload length	Header CRC	Cycle count	Payload	Trailer
5 bits	11 bits	7 bits	11 bits	6 bits		

To trigger on a frame ID, you have to define a condition and one or two identifier patterns. The second identifier pattern is required to specify a range with conditions "In range" and "Out of range". In binary format, use the following characters: 1; 0; or X (any bit). The use of X is restricted to the conditions "Equal" and "Not equal". If the identifier is not relevant for the trigger setup, set it to "Off".

The maximum length of the pattern is 11 bit. The bit pattern editor helps you to enter the pattern in any format, see [chapter 14.1.4, "Bit Pattern Editor"](#), on page 425.

Trigger type: "Identifier + data"

Remote command:

[TRIGger<m>:FLXRay:FCONdition](#) on page 1020

[TRIGger<m>:FLXRay:FMIN](#) on page 1020

[TRIGger<m>:FLXRay:FMAX](#) on page 1020

Payload length (min/max)

The payload length contains the number of words transmitted in the payload segment. Information is transmitted in 2-byte words, so the number of data bytes in the payload segment is twice the payload length.

Indicators	Frame ID	Payload length	Header CRC	Cycle count	Payload	Trailer
5 bits	11 bits	7 bits	11 bits	6 bits		

To trigger on the payload length, you have to define a condition and one or two numbers of words. The second number is required to specify a range with conditions "In range" and "Out of range". If the payload length is not relevant for the trigger setup, set it to "Off".

Trigger type: "Identifier + data"

Remote command:

[TRIGger<m>:FLXRay:PCONdition](#) on page 1021

[TRIGger<m>:FLXRay:PMIN](#) on page 1021

[TRIGger<m>:FLXRay:PMAX](#) on page 1021

Cycle count (min, max), Step

The cycle count contains the number of the current FlexRay cycle.

Indicators	Frame ID	Payload length	Header CRC	Cycle count	Payload	Trailer
5 bits	11 bits	7 bits	11 bits	6 bits		

To trigger on the cycle count, you have to define a condition and one or two numbers. If the condition is a range ("In range" or "Out of range"), a second number "Cycle count max" is required.

Additionally, you can define a "Step" to trigger on each n-th cycle inside the given range. This allows for specific triggering if slot multiplexing is used.

If the cycle count is not relevant for the trigger setup, set it to "Off".

Trigger type: "Identifier + data"

Remote command:

[TRIGger<m>:FLXRay:CENable](#) on page 1022

[TRIGger<m>:FLXRay:CMIN](#) on page 1022

[TRIGger<m>:FLXRay:CMAX](#) on page 1022

[TRIGger<m>:FLXRay:CSTep](#) on page 1023

Position, Index (min, max) - Data setup

Sets the position of the first byte of data bit pattern within the payload segment. You can define an exact position, or a position range.

Trigger type: "Identifier + data"

- "Position" Operator for the data position. Select "Off", if the position of the required pattern is not relevant.
- "Index" Sets the number of data bytes to be skipped after start of the payload segment if "Position" is "Equal" or "Greater or equal". The index 0 is associated with the first data byte.
- "Index min, Index max" If the "Position" operator defines a range, the indexes of the first and the last byte are defined between which the required bit pattern may start.

Remote command:

[TRIGger<m>:FLXRay:DPOperator](#) on page 1023

[TRIGger<m>:FLXRay:DPOsition](#) on page 1024

[TRIGger<m>:FLXRay:DPTO](#) on page 1024

Condition, Data (min, max) - Data setup

Specifies the data bit pattern to be found in the payload segment. The starting point of the pattern is defined by "[Position, Index \(min, max\) - Data setup](#)" on page 484. The pattern comparison is byte-aligned, and the instrument triggers at the end of a byte.

- "Condition" Sets the operator to set a specific data pattern ("Equal" or "Not equal") or a data range.
- "Data (min/max)" Enter the bytes in msb first bit order. The maximum pattern length is 8 bytes.
In binary format, you can use the following characters: 1; 0; or X (any bit). The bit pattern editor helps you to enter the pattern in any format, see [chapter 14.1.4, "Bit Pattern Editor"](#), on page 425.

Remote command:

[TRIGger<m>:FLXRay:DCONdition](#) on page 1024

[TRIGger<m>:FLXRay:DMIN](#) on page 1025

[TRIGger<m>:FLXRay:DMAX](#) on page 1025

Symbol

Triggers on a symbol or on a wakeup pattern.

Trigger type: "Symbol"

- "CAS/MTS" Collision Avoidance Symbol / Media access Test Symbol. These symbols are identical and can be sent in the optional symbol window at the end of a communication cycle. They are used to avoid collisions during the system start.
- "Wakeup Pattern" The wakeup pattern is sent to activate the nodes of the system.

Remote command:

[TRIGger<m>:FLXRay:SYMBOL](#) on page 1025

Error conditions

Triggers on one or more errors in the frame.

Trigger type: "Error conditions"

"FSS"	Error in a Frame Start Sequence. FSS follows the Transmission Start Sequence TSS at the beginning of each frame.
"BSS"	Error in a Byte Start Sequence. The BSS is transmitted before each byte.
"FES"	Error in Frame End Sequence. FES indicates the end of each frame.
"Header CRC"	Error in a cyclic redundancy check code of the header data which covers mainly frame ID and payload length.
"Payload CRC"	Error in a cyclic redundancy check code of the complete frame.

Remote command:

[TRIGger<m>:FLXRay:FSSerror](#) on page 1026

[TRIGger<m>:FLXRay:BSSerror](#) on page 1025

[TRIGger<m>:FLXRay:FESerror](#) on page 1026

[TRIGger<m>:FLXRay:HRCerror](#) on page 1026

[TRIGger<m>:FLXRay:PCRCerror](#) on page 1026

14.7.3 FlexRay Label List

Label lists are protocol-specific. An FlexRay PTT file contains four values for each identifier:

- "ID / Addr": number of the slot in which the frame is transmitted
- "Base cycle" and "Repetition": define the cycle indexes for which the identifier applies. Base cycle defines the first applied cycle. There are 64 cycles in a FlexRay communication. The same identifier can be shared by different devices, and each device uses the identifier at different cycles. For example:
 0x0AB,0,2, Ignition_Info: uses cycles 0,2,4,6,...,62
 0x0AB,1,2, GearBoxInfo: uses cycles 1,3,5,7,...,63
- "Symbolic label": symbolic name of the identifier, specifying the device function.

Example: FlexRay PTT file

```
# -----
@FILE_VERSION = 1.0
@PROTOCOL_NAME = flexray
# -----
# Labels for FlexRay protocol
#   Column order: Identifier, Base cycle, Cycle repetition, Label
# -----
# ----Definition----
0x01D,0,2,DriveTrain
0x03D,3,3,EngineData
0x0AB,0,2,Ignition_Info
0x0AB,1,2,GearBoxInfo
```

```

0x1C4,1,2,ABSdata
0x1F5,0,1,BrakeControl
0x200,0,1,Engine_Status
0x2BA,0,1,Airbag_Status
0x2D9,0,1,TP_Console
0x340,0,2,CAN_Gateway
0x38B,55,1,MOST_Gateway
0x3EA,0,1,PressureInfo
# -----

```

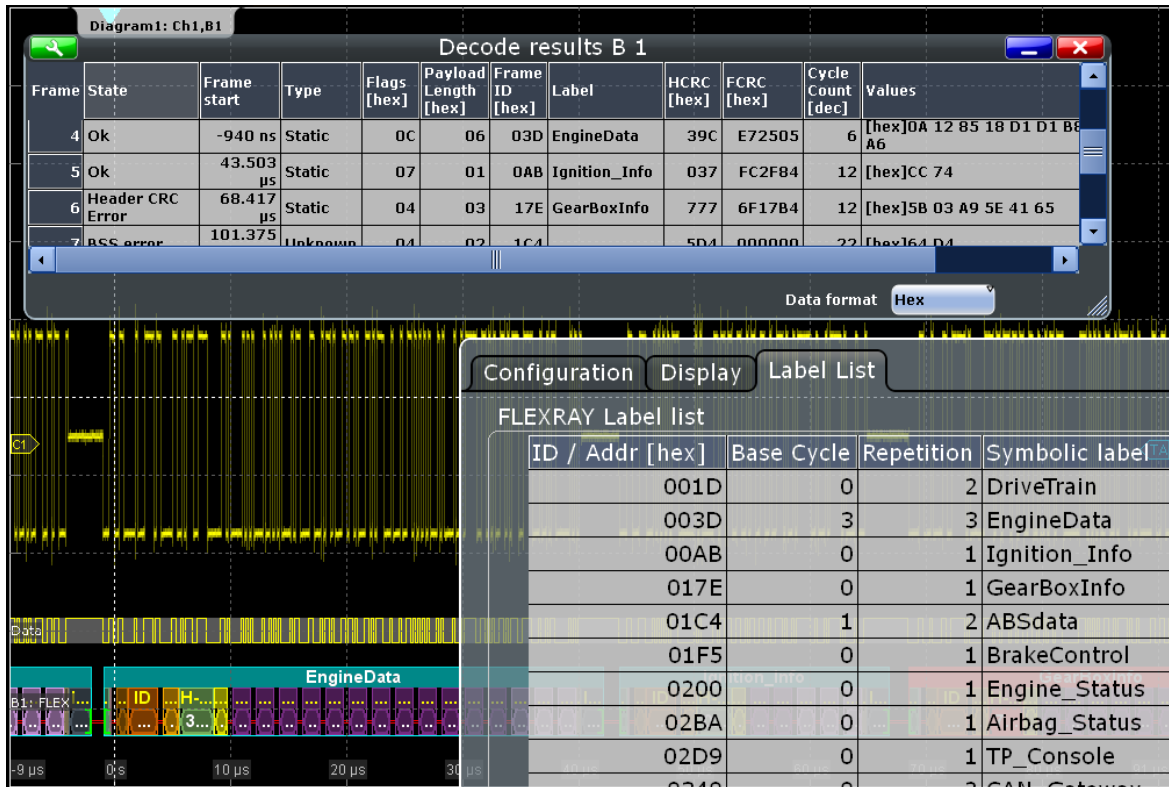

For general information on the "Label List" tab, see [chapter 14.1.3, "Label Lists"](#), on page 422.

SCPI command

- `BUS<m>:FLXRay:FRAMe<n>:SYMBol?` on page 1033

14.7.4 FlexRay Decode Results

To display the decoded signal below the waveforms, enable "Decode" on the "Configuration" tab.

Additionally, you can display the binary signal and the detailed decoding results using the corresponding settings on the "Display" tab, see [chapter 14.1.2, "Display"](#), on page 420.

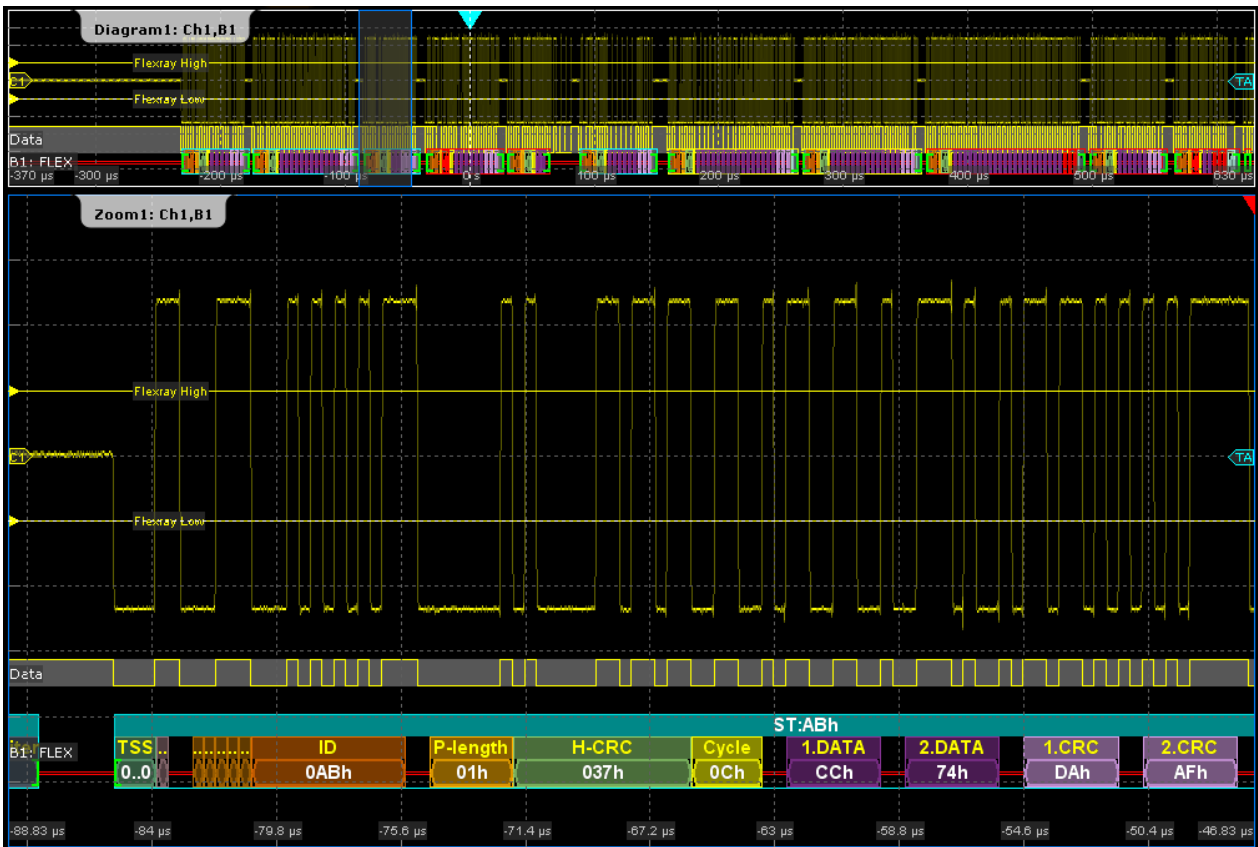

Fig. 14-16: FlexRay - decoded static slot

Data is decoded and displayed in the order of its reception. The "Decode results" box shows the detailed decoded data for each frame as it is received.



Fig. 14-17: FlexRay - decoded dynamic slot and results table

Table 14-6: Content of the "Decode results" table

Column	Description
State	Overall state of the frame. "Insufficient waveform length" indicates that the frame is not completely contained in the acquisition. Change the horizontal scale, or move the reference point to the left to get a longer acquisition.
Frame start	Time of frame start
Type	Frame type: Frame of the static segment, frame of the dynamic segment, wakeup frame, symbol in the frame
Flags	State of indicator bits
Payload length	Number of data words in the payload segment.
Frame ID	Value of the frame ID (slot number)
HCRC	Value of the header CRC
FCRC	Value of the frame CRC
Cycle count	Number of the current FlexRay cycle
Values	Value of the data bytes. The data format is selected below the table. Wakeup and symbol frames frames do not transmit data, therefore "-" is displayed.

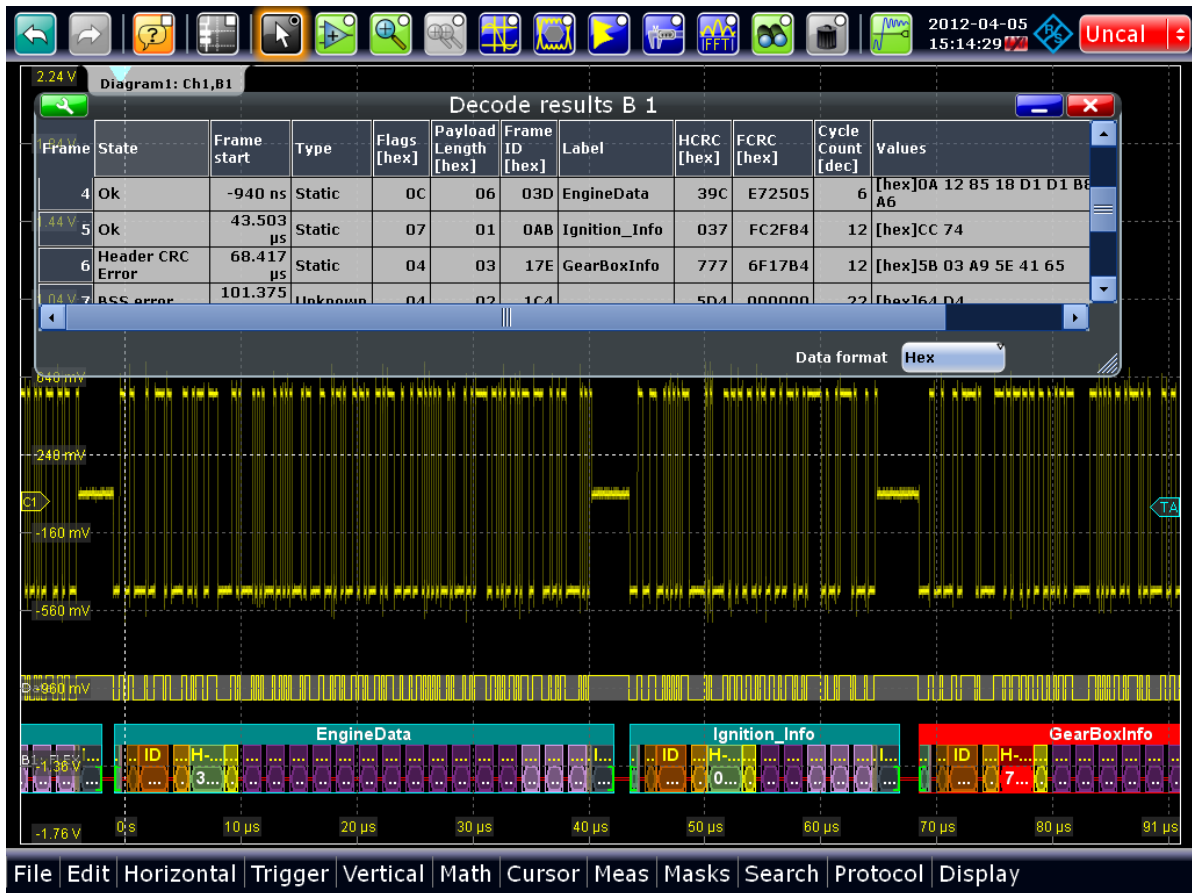

Fig. 14-18: FlexRay - decode results with applied label list

SCPI commands:

- `BUS<m>:FLXRay:FCOut? on page 1027`
- `BUS<m>:FLXRay:FRAMe<n>:DATA? on page 1029`
- `BUS<m>:FLXRay:FRAMe<n>:ADID? on page 1029`
- `BUS<m>:FLXRay:FRAMe<n>:CSState? on page 1030`
- `BUS<m>:FLXRay:FRAMe<n>:CSValue? on page 1031`
- `BUS<m>:FLXRay:FRAMe<n>:CYCount? on page 1030`
- `BUS<m>:FLXRay:FRAMe<n>:FCState? on page 1031`
- `BUS<m>:FLXRay:FRAMe<n>:FCValue? on page 1032`
- `BUS<m>:FLXRay:FRAMe<n>:FLAGs? on page 1029`
- `BUS<m>:FLXRay:FRAMe<n>:PAYLength? on page 1030`
- `BUS<m>:FLXRay:FRAMe<n>:STATus? on page 1027`
- `BUS<m>:FLXRay:FRAMe<n>:START? on page 1028`
- `BUS<m>:FLXRay:FRAMe<n>:STOP? on page 1028`
- `BUS<m>:FLXRay:FRAMe<n>:TYPE? on page 1028`

14.8 Audio Signals (Option R&S RTO-K5)

The R&S RTO can analyze several standard and de-facto industry standard signals: I²S Inter-IC Sound standard audio format, left justified and right justified data formats and Time Division Multiplexed (TDM) audio format.

• Audio Protocols	490
• Audio Signal Configuration	492
• Audio Trigger	496
• Audio Decode Results	499
• Track and Trend	502

14.8.1 Audio Protocols

All audio protocols use 3 lines:

- The clock line generates the bit clock.
- The word select line (WS, also known as word clock) defines the frame start and the maximum length of the data word.
For pulse code modulated signals (I²S standard, left and right justified data formats), the level of the WS signal assigns the data words to the left and right channels.
TDM uses frame synchronization pulses on the WS line to identify the beginning of a frame.
- The data line transmits the audio data in time-multiplexed data channels.

14.8.1.1 I²S Standard

I²S standard interfaces transmit two PCM coded audio channels. The WS line selects the channel being transmitted - left or right channel. Usually, 32 bits are transmitted on each channel. The data word can be shorter than the channel length, and the receiver ignores the remaining bits. The first byte of the audio word is delayed one clock period from the leading edge of the word select pulse. The R&S RTO can decode I²S standard signals with MSBF and LSBF bit order.

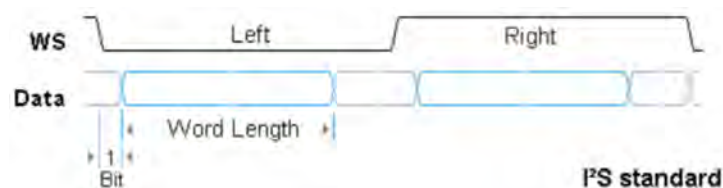

14.8.1.2 Left Justified Data Format

The left justified data format is very similar to the I²S standard, but the first byte of the audio word is aligned with the leading edge of the word select pulse. Thus the audio word is left justified within the frame. The data word can be shorter than the channel length.

In addition to the standard configuration, the R&S RTO can analyze also left justified data formats which send the data word with offset to the WS edge. The bit order can be MSBF or LSBF.

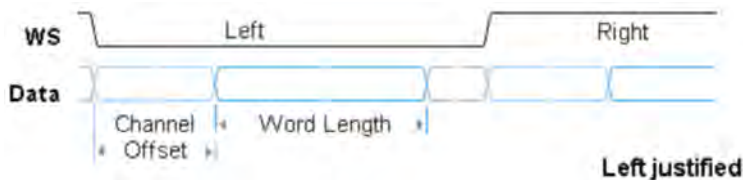

14.8.1.3 Right Justified Data Format

The right-justified data format is similar to the left-justified, but the last byte of the word in the frame is aligned with the trailing edge of the word select pulse. Thus the audio word is right-aligned within the frame.

The R&S RTO can decode right justified signals with MSBF and LSBF bit order.

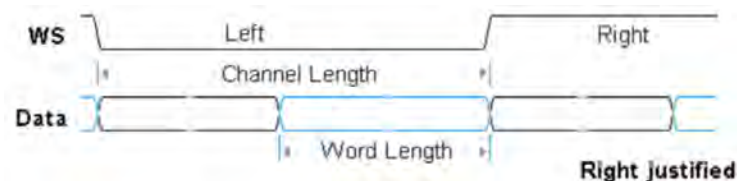

14.8.1.4 TDM

The Time Division Multiplexed (TDM) audio format is not standardized and provides high flexibility for transfer of more than two audio data channels on one line. On the word select line, it uses frame synchronization pulses to identify the beginning of a frame. On the data line, channel blocks of a defined length are transmitted. Each block contains an audio word that can be shorter than the channel length.

Each frame can start with frame offset bits, which precede the first channel. Inside the channel, the audio word also can have an offset to the channel start.

Channel length, channel offset and word length are dependent values:

$$\text{Channel length} \geq \text{Word length} + \text{Channel offset}$$

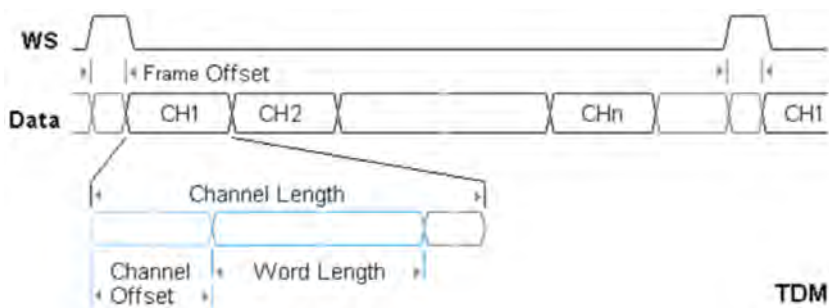

14.8.2 Audio Signal Configuration

Access: PROTOCOL > "Configuration" tab > "Protocol" = *Audio*

In the "Configuration" tab you configure the audio signal. Several audio signal variants are available: the I²S standard signal, the left- and right-justified data formats, and the TDM interface.

For all audio signal variants, you define the line sources and their polarities. Additionally, if coupling is active, one threshold for all sources; if coupling is not enabled, three thresholds for each source.

Specific settings for I²S standard signals are:

- "Channel order" on page 495
- "Word length" on page 495
- "Bit order" on page 495
- For left-justified data:
"Channel offset" on page 495
- For right-justified data:
"CH length" on page 496

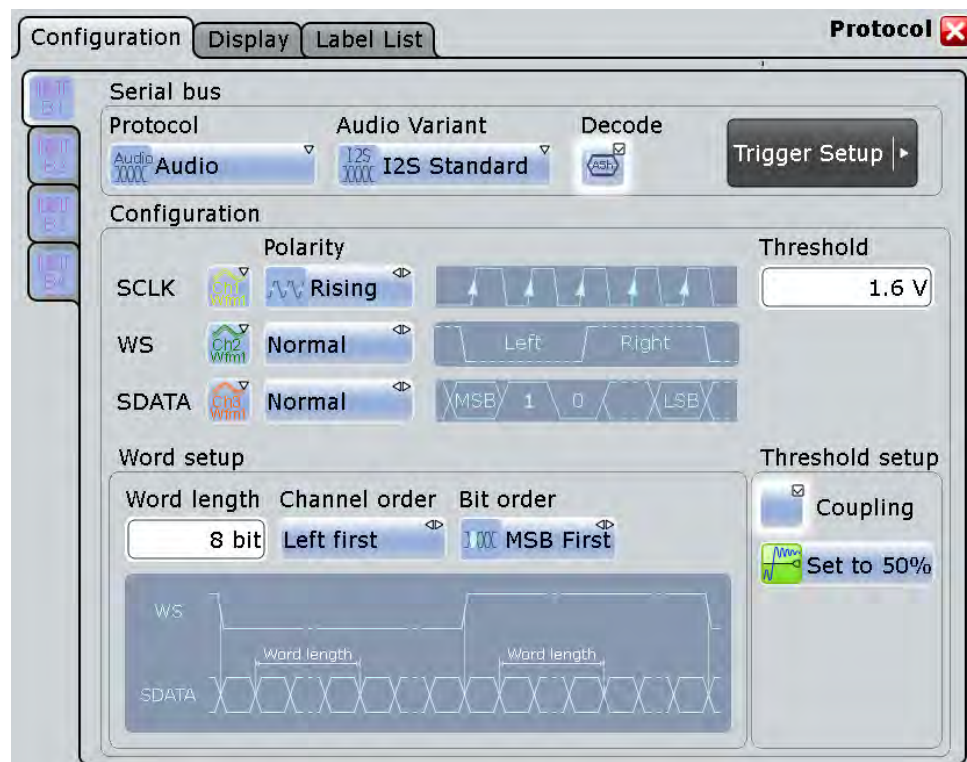

Specific settings for TDM audio signals are:

- "Word length" on page 495
- "Bit order" on page 495
- "Channel offset" on page 495
- "#TDM CHs" on page 496

- "Frame offset" on page 496
- "CH length" on page 496

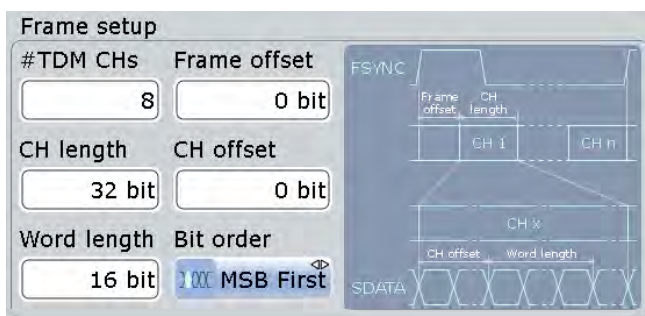

Make sure that the tab of the correct serial bus is selected on the left side.

Audio Variant

Selects the protocol variant of the audio signal. The configuration possibilities exceed the definitions of the standards.

- "I2S Standard" Inter-IC Sound standard audio format.
It uses the SCLK, WS and SDATA lines. The first byte of the audio word is delayed one clock period from the leading edge of the word select pulse.
- "Left justified" The left-justified data format uses the same lines as I²S standard. The first byte of the audio word is aligned with the leading edge of the word select pulse, or left-justified within the frame. The format is word-length independent.
- "Right justified" The right-justified data format is similar to the left-justified, but the last byte of the last word in the frame is aligned with the trailing edge of the word select pulse, or right-aligned within the frame. This format is not word-length independent.
- "TDM" The Time Division Multiplexed audio format is not standardized and provides high flexibility for transfer of up to 8 audio data channels on one line. Instead of word select, it uses frame synchronization pulses to identify the beginning of a frame. On the data line, channel blocks of a defined length are transmitted. Each block contains an audio word followed by a number of zero bits to complete the block.

Remote command:

`BUS<m>:I2S:AVARiant` on page 1033

SCLK

Selects the source of the clock line. Waveform 1 of channel signals, math waveforms, and reference waveforms can be used for decoding.

Alternatively, digital channels can be used if MSO option R&S RTO-B1 is installed. Digital and analog channels cannot be used at the same time.

For triggering on a serial bus, analog or digital input channels are required. Math and reference waveforms are not available.

Remote command:

[BUS<m>:I2S:CLOCK:SOURce](#) on page 1034

SCLK Polarity

Sets the polarity of the clock signal, that is the edge at which the instrument samples the data on the data line. Usually, the rising edge is used. The R&S RTO can also analyze the converse setup.

Remote command:

[BUS<m>:I2S:CLOCK:POLarity](#) on page 1034

WS / FSYNC

Selects the source of the word select line for I²S standard, left- and right-justified data formats, or the source of the frame synchronization pulse for TDM audio signals. The same waveforms as for [SCLK](#) are available, and the same restrictions are applied.

Remote command:

[BUS<m>:I2S:WSElect:SOURce](#) on page 1034

WS / FSYNC Polarity

For a word select line, the polarity defines the word select values assigned to the left and right channels.

- "Normal": usually, 0 indicates the left channel, and 1 indicates the right channel.
- "Inverted": 0 indicates the right channel, and 1 the left channel.

For an FSYNC line (TDM), the polarity defines the edge of the FSYNC pulse that identifies the beginning of a frame. The frame starts exactly at the next clock edge following the selected FSYNC edge.

- "Normal": usually, the frame begins with a rising edge.
- "Inverted": the frame begins with a falling edge.

Remote command:

[BUS<m>:I2S:WSElect:POLarity](#) on page 1035

SDATA

Selects the source of the audio data line. The same waveforms as for [SCLK](#) are available, and the same restrictions are applied.

Remote command:

[BUS<m>:I2S:DATA:SOURce](#) on page 1035

SDATA Polarity

Defines the interpretation of high and low signal states.

- "Active high": HIGH (signal level above the threshold level) = 1 and LOW (signal level below the threshold level) = 0
- "Active low": HIGH = 0 and LOW = 1

Remote command:

[BUS<m>:I2S:DATA:POLarity](#) on page 1036

Threshold setup

Sets the threshold value for digitization of signals for each line. If the signal value on the line is higher than the threshold, the signal state is high. Otherwise, the signal state is considered low if the signal value is below the threshold. The interpretation of HIGH and LOW is defined by the polarity.

There are three ways to set the threshold:

- "Set to 50%"
Executes the measurement of reference levels and sets the thresholds to the middle reference level of the measured amplitude.
This option is only available for analog sources.
- "Coupling"
Sets all thresholds to the same value. Enter the value in the "Threshold" field.
- "Threshold"
Enter individual values for each line directly in the fields.

Remote command:

[BUS<m>:I2S:TCoupling](#) on page 1036

[BUS<m>:I2S:CLOCK:THReshold](#) on page 1036

[BUS<m>:I2S:DATA:THReshold](#) on page 1037

[BUS<m>:I2S:WSElect:THReshold](#) on page 1036

[BUS<m>:SETReflevels](#) on page 939

Channel order

Defines if the left or the right channel is the first channel in the frame.

The setting is not available for TDM audio signals.

Remote command:

[BUS<m>:I2S:CHANnel:ORDer](#) on page 1037

Word length

Defines the number of bits in an audio data word. The minimum length is 4 bit, the maximum is 32 bit.

Remote command:

[BUS<m>:I2S:WLENgth](#) on page 1037

Bit order

Sets the bit order in the audio data words. Usually, the MSB is transmitted first.

Remote command:

[BUS<m>:I2S:BORDer](#) on page 1038

Channel offset

Sets the number of bits between the channel start and the start of the audio word. The setting is available for left-justified data format and TDM audio signals.

For TDM, possible values depend on the channel size and the word size. The maximum delay is *Channel length - Word length*.

Remote command:

[BUS<m>:I2S:CHANnel:OFFSet](#) on page 1038

#TDM CHs

Sets the number of channels transmitted on the TDM audio line.

Remote command:

[BUS<m>:I2S:CHANnel:TDMCount](#) on page 1038

Frame offset

Sets the number of bits between the frame start and the start of the first channel of a TDM audio line. The maximum offset is 256 bit. Each FSYNC edge restarts the offset count.

Remote command:

[BUS<m>:I2S:FOFFset](#) on page 1038

CH length

Sets the number of bits in a channel block for right-justified data format and TDM audio signals.

Remote command:

[BUS<m>:I2S:CHANnel:LENGth](#) on page 1039

14.8.3 Audio Trigger

Access: TRIGGER > "Source" = *Serial bus* and "Protocol" = *Audio*



Make sure that:

- the trigger sequence is set to "A only"
- the trigger source is "Serial bus", and the data source(s) of the bus are channel signals
- the correct serial bus is selected
- the correct protocol is selected

Type

Selects the trigger type.

"Data" Sets the trigger on a data word or a data range that occurs on a specified channel or on any channel. The instrument triggers on the last bit of the specified data pattern.

Description of specific trigger type settings:

- ["Channel"](#) on page 498
- ["Data condition"](#) on page 498

"Window" This trigger checks if the decoded data values stay inside a "window" that is formed by a data range and a time specified by a number of subsequent words. It considers a selected channel or all channels. The instrument triggers at the end of the last word. Thus, for example, you can trigger on a pause.

Description of specific trigger type settings:

- "Channel" on page 498
- "Data condition" on page 498
- "Window length" on page 498

"Frame condition" Sets the trigger on an AND combination of data conditions on different channels. The instrument triggers if all conditions are met inside one frame.

AND slot	Channel	Condition	Min	Max
1.	Left	[]	[dec]+10	[dec]+20
2.	Right	[]	[dec]+0	[dec]+10

Description of specific trigger type settings:

- "Channel" on page 498
- "Data condition" on page 498

Description of specific trigger type settings: "Channel" on page 498 and .

"Word select" Triggers on the selected edge of the WS line, that is, on the beginning of the left or right channel (I²S, left- and right-justified). For TDM signals, it triggers on the selected edge of the FSYNC line - on the beginning of a TDM frame.

The trigger time is the first clock edge after the selected WS/FSYNC edge.

Description of specific trigger type settings: "Word select: Slope" on page 499.

"Error condition" The oscilloscope uses the WS or FSYNC line to monitor the channel and frame length. An error is detected when two consecutive frames have different length. The instrument triggers on the first clock edge after error detection.

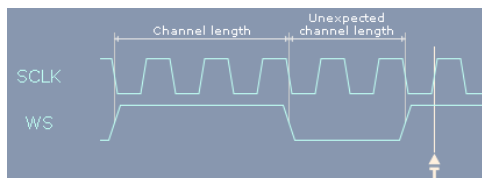

Fig. 14-19: Trigger on errors in I²S standard signal with clock polarity "Rising"

Remote command:

TRIGger<m>:I2S:TYPE on page 1039

Channel

Selects the audio channel on which the instrument looks for the specified data condition.

The setting is relevant for trigger types Data, Window and Frame condition.

Note: For TDM signals, the number of available channels depends on the configuration of the audio bus, see "[#TDM CHs](#)" on page 496.

Remote command:

[TRIGger<m>:I2S:TCONdition<n>:CHANnel](#) on page 1040

Data condition

The data condition setup consists of the operator and one or two data patterns.

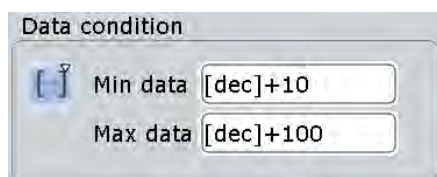

The settings are relevant for trigger types Data, Window and Frame condition.

- "Operator" Defines the operator to set a specific data word ("Equal" or "Not equal") or a data range.
- "Min data" Defines the data pattern. The data length is limited to the word length. Enter the pattern using the bit order defined in the signal configuration. X (don't care) is not allowed. Usually, audio words are signed numbers in 2's complement format. The bit pattern editor helps you to enter the pattern in any format, see [chapter 14.1.4, "Bit Pattern Editor"](#), on page 425.
- "Max data" The second data pattern is required to specify a range with conditions "In range" and "Out of range".

Remote command:

[TRIGger<m>:I2S:TCONdition<n>:CONDtion](#) on page 1041

[TRIGger<m>:I2S:TCONdition<n>:DMIN](#) on page 1042

[TRIGger<m>:I2S:TCONdition<n>:DMAX](#) on page 1042

Window length

Sets the number of words that is used as time limit for the "Window" trigger type. The instrument triggers if the data condition is fulfilled on the same channel for the given number of subsequent frames.

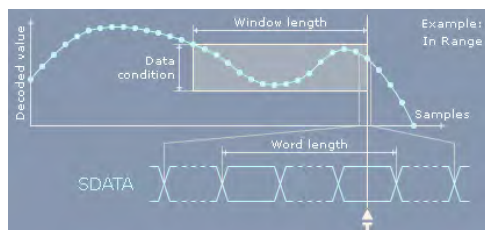

Remote command:

[TRIGger<m>:I2S:SOWords](#) on page 1043

Word select: Slope

Sets the edge of the WS or FSYNC signal as trigger condition. The instrument triggers on the first clock edge after the specified edge.

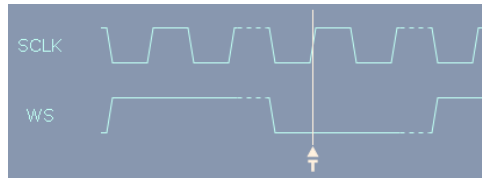

Fig. 14-20: Word select trigger on I²S standard signal with clock polarity "Rising" and "Normal" WS polarity (left = 0)

The WS edge indicates the start of the left or right channel. The FSYNC edge indicates the frame start. Consider the [WS / FSYNC Polarity](#) setting in the "Protocol Configuration" dialog box.

Remote command:

[TRIGger<m>:I2S:WSSLope](#) on page 1043

14.8.4 Audio Decode Results

To display the decoded signal below the waveforms, enable "Decode" on the "Configuration" tab.

Additionally, you can display the binary signal and the detailed decoding results using the settings on the "Display" tab, see [chapter 14.1.2, "Display"](#), on page 420.

Data is displayed in the order of its reception. All decoded values consider the "Bit order" configuration setting of the audio signal. Binary values in the combs of the decoded signal additionally consider the "Binary bit order" setting in the "Display" tab. Thus, you can read the bits of an LSB first signal in LSB first order while the results table displays the correct values MSB first.

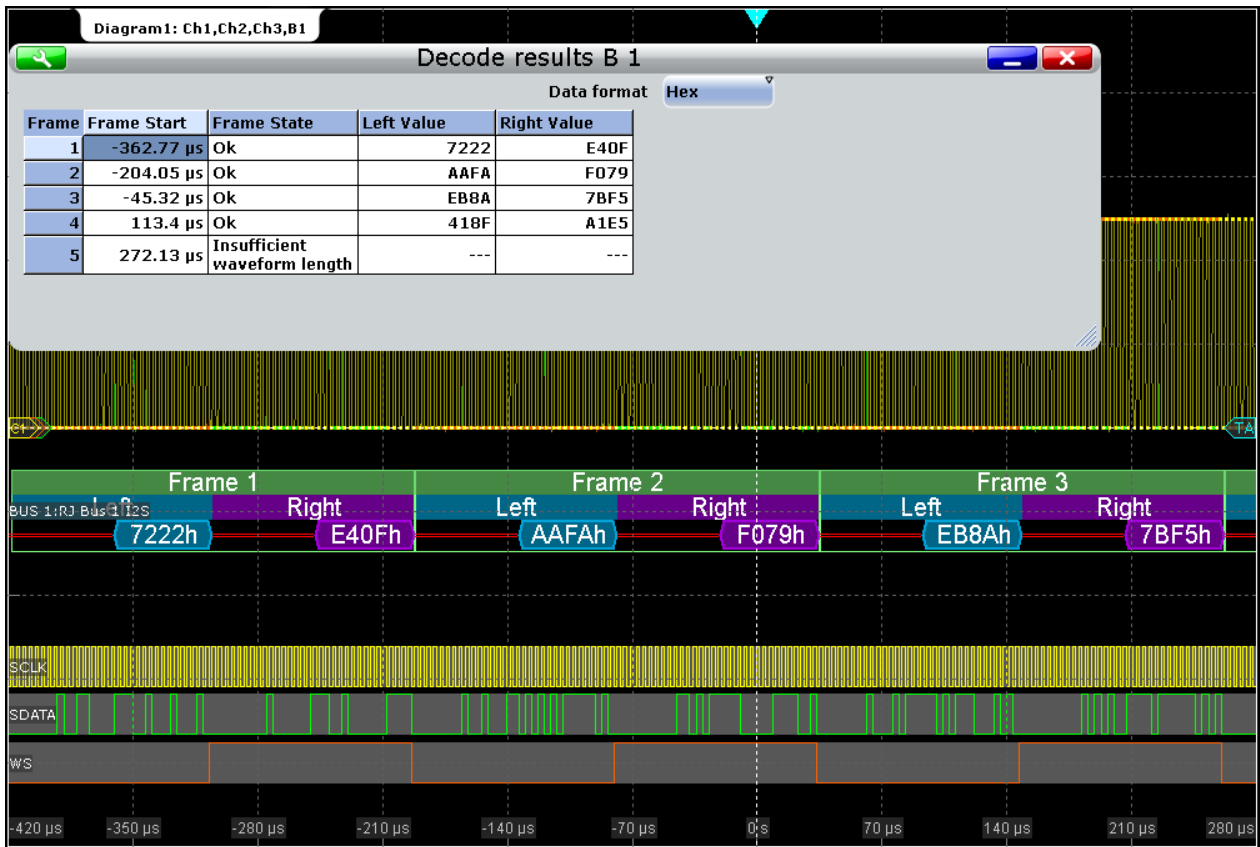

Fig. 14-21: Decoded audio signal, right-justified data format

- green = frame
- blue = left channel
- violet = right channel
- orange = frame/channel is not completely contained in the acquisition
- red = error

Table 14-7: Content of the "Decode results" table

Column	Description
Frame Start	Time of the frame start
Frame State	Overall state of the frame. "Insufficient waveform length" indicates that the frame is not completely contained in the acquisition.
Left Value	Data value of the left channel
Right Value	Data value of the right channel

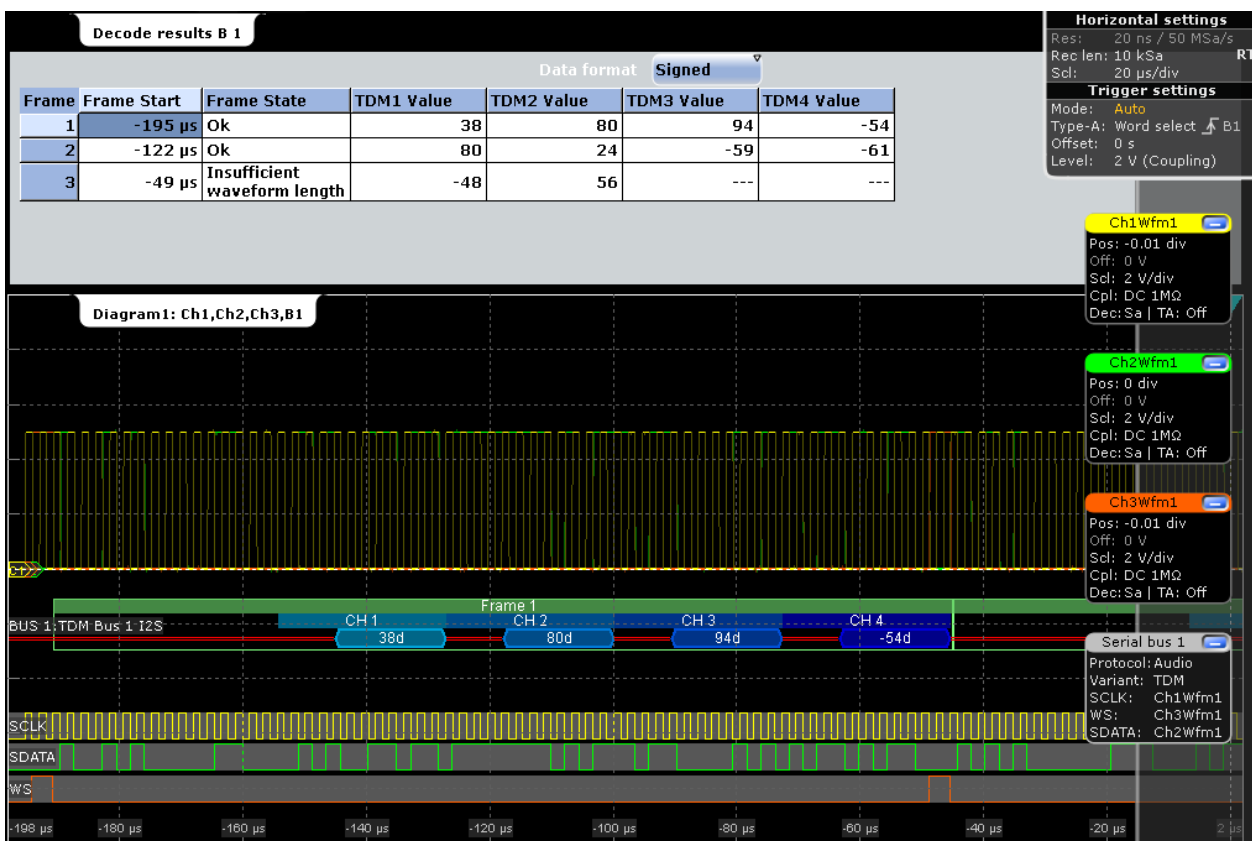

Fig. 14-22: Decoded TDM signal with 4 channels, frame offset 16 bit, channel offset 4 bit, word length 8 bit and inverted FSYNC and SDATA polarity

Table 14-8: Content of the "Decode results" table

Column	Description
Frame Start	Time of the frame start
Frame State	Overall state of the frame. "Insufficient waveform length" indicates that the frame is not completely contained in the acquisition.
TDM<x> Value	Data value of the TDM channel

SCPI commands:

- [BUS<m>:I2S:FCOunt?](#) on page 1044
- [BUS<m>:I2S:FRAMe<n>:STATe?](#) on page 1044
- [BUS<m>:I2S:FRAMe<n>:START?](#) on page 1044
- [BUS<m>:I2S:FRAMe<n>:STOP?](#) on page 1044
- [BUS<m>:I2S:FRAMe<n>:LEFT:VALue?](#) on page 1045
- [BUS<m>:I2S:FRAMe<n>:RIGHT:VALue?](#) on page 1045
- [BUS<m>:I2S:FRAMe<n>:LEFT:STATe?](#) on page 1045
- [BUS<m>:I2S:FRAMe<n>:RIGHT:STATe?](#) on page 1045
- [BUS<m>:I2S:FRAMe<n>:TDM<o>:STATe?](#) on page 1045

- [BUS<m>:I2S:FRAME<n>:TDM<o>:VALue?](#) on page 1046

14.8.5 Track and Trend

14.8.5.1 Track

The track is a waveform that shows measurement values in time-correlation to the audio signal. It is the graphical interpretation of all measurement values of a single acquisition. For audio signals, the measurement values on the vertical axis are the decoded values of the audio channels, the time scale is equivalent to the scale of the source waveforms.

You can display the values of several channels in one track, or create one track for each channel and display them in parallel.

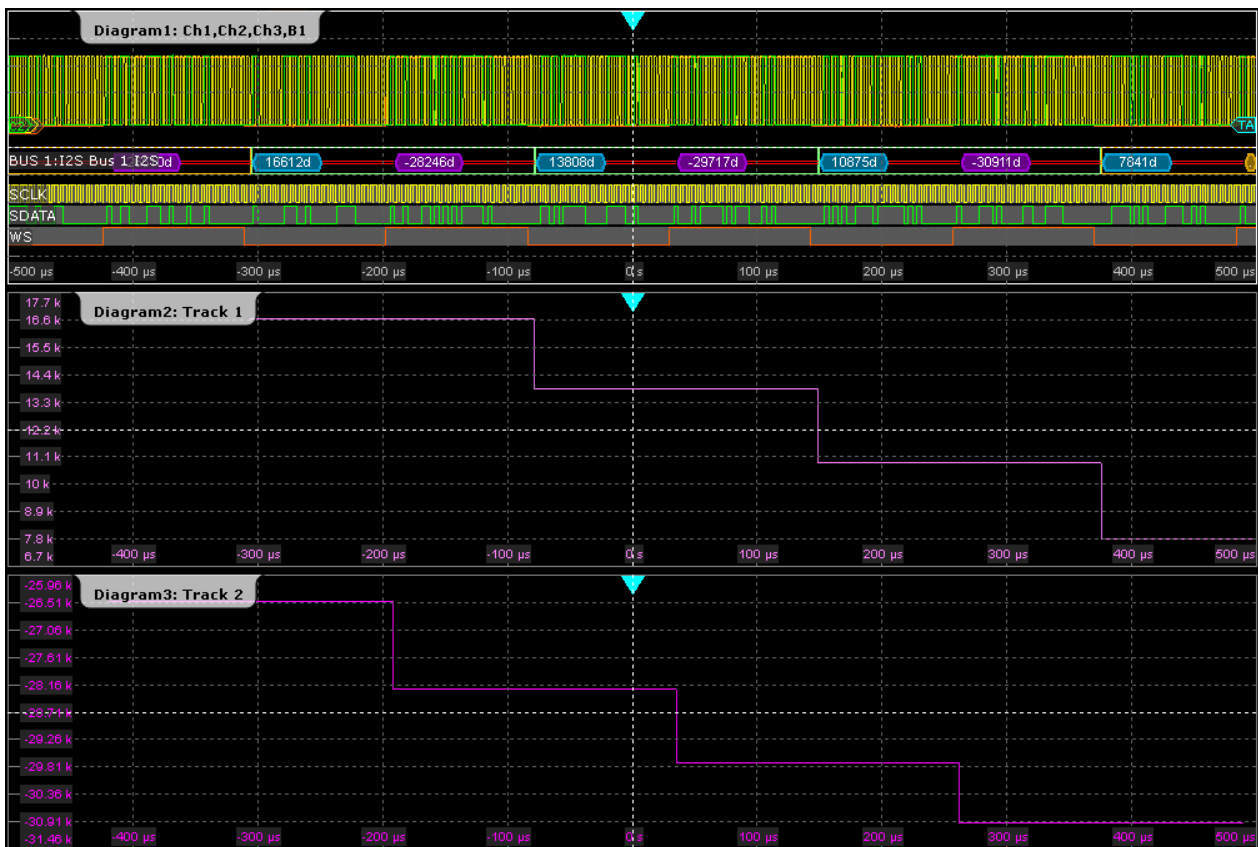

Fig. 14-23: Tracks of left and right channel of I²S standard signal

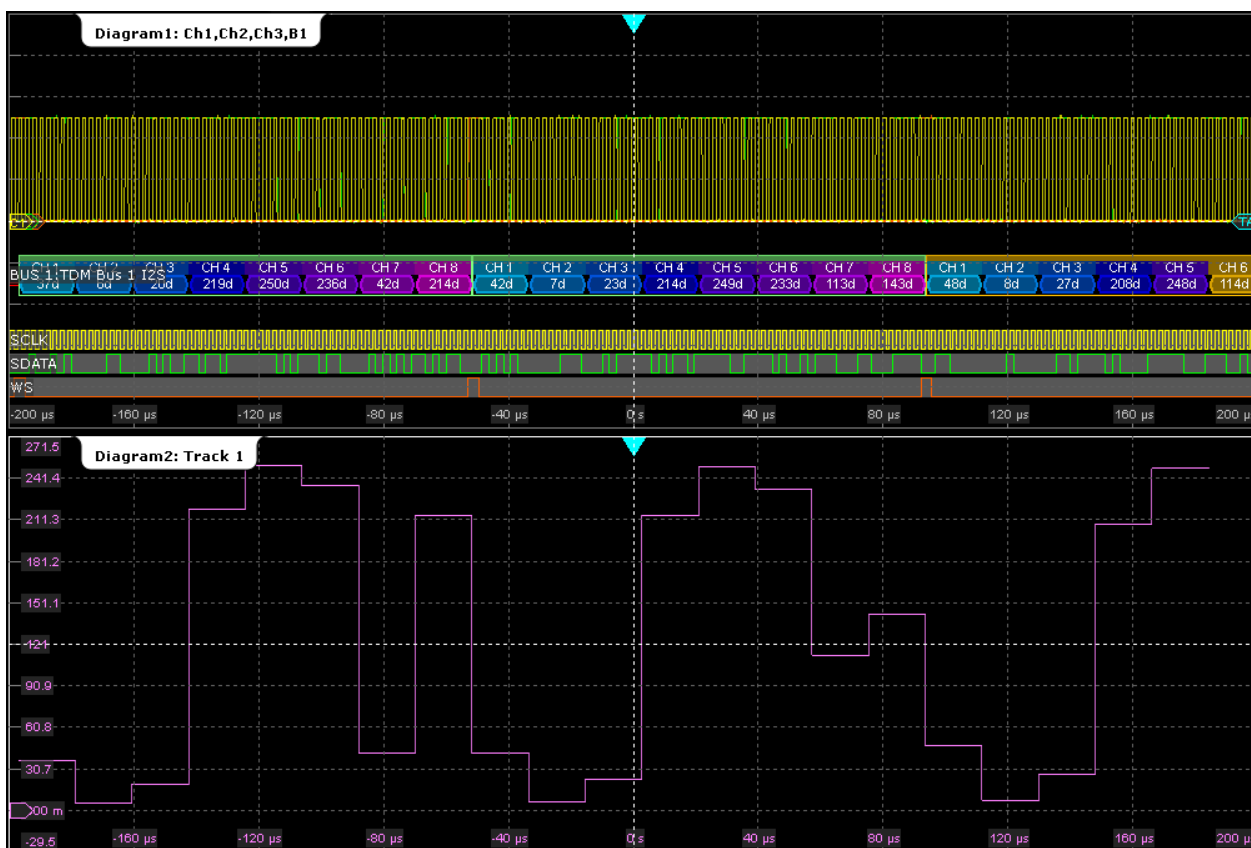

Fig. 14-24: Track of all 8 channels of a TDM signal

The track is a special measurement waveform, so it can be used for further analysis: cursor measurements and zoom.

Displaying and Configuring a Track

To get a first impression of the track, you can display it quickly. For further analysis, some configuration settings are available.

1. Press the PROTOCOL key.
2. Select the "Display" tab.
3. Tap the "Show Track Waveform(s)" button.
4. Select the "Audio channel" to be tracked.

The track waveform with default settings is enabled and displayed.

Tip: Alternatively, you can enable the track in the "Measurements" dialog box, on the "LongTerm/Track" tab if the audio serial bus is selected as source of the measurement on the "Setup" tab.

5. If you want to change the track settings, tap "Track Setup".
6. By default, the track is displayed using "Continuous auto scale". If you want to change the scaling, proceed as follows:

- Select the "LongTerm/Track" tab.
- Disable "Continuous auto scale".
- Adjust "Vertical scale" and "Vertical offset".

Track Settings in Protocol Setup

You can enable the track waveforms in the protocol display settings. As the track is based on measurement, you can use the "Measurement" dialog box alternatively, see "[Track Enabling in Measurement Setup](#)" on page 506.

Access: PROTOCOL > "Display tab"

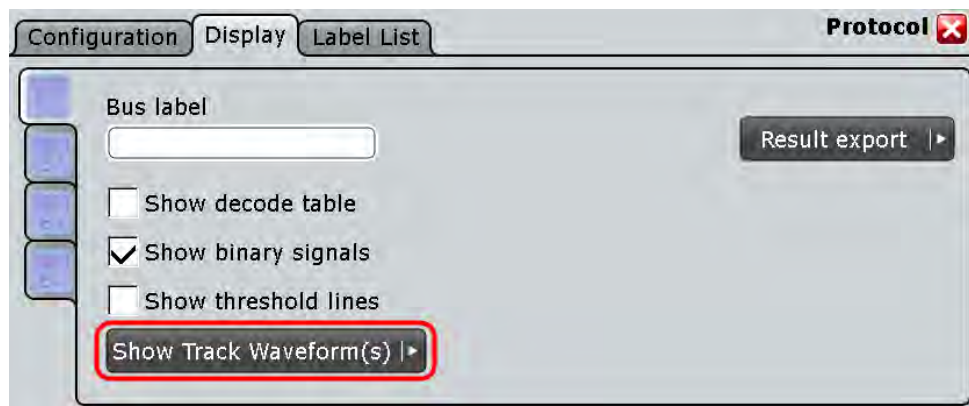

To set the vertical scale of the track waveform, use the measurement scale settings on the "Measurements - Long Term/Track" tab, see "[Meas scaling](#)" on page 280.

Show Track Waveform(s)

Enables and displays the track(s) for the selected channels of the decoded bus for the current acquisition using unsigned data format and continuous auto scale.

See also: [chapter 14.8.5.1, "Track"](#), on page 502.

Remote command:

[BUS<m>:I2S:TRACk:LEFT](#) on page 1046

[BUS<m>:I2S:TRACk:RIGHT](#) on page 1046

[BUS<m>:I2S:TRACk:TD1Ch](#) on page 1047

[BUS<m>:I2S:TRACk:TD2Ch](#) on page 1047

[BUS<m>:I2S:TRACk:TD3Ch](#) on page 1047

[BUS<m>:I2S:TRACk:TD4Ch](#) on page 1047

[BUS<m>:I2S:TRACk:TD5Ch](#) on page 1047

[BUS<m>:I2S:TRACk:TD6Ch](#) on page 1047

[BUS<m>:I2S:TRACk:TD7Ch](#) on page 1047

[BUS<m>:I2S:TRACk:TD8Ch](#) on page 1047

Track and Trend Settings in Measurement Setup

As track and trend are based on measurements, the main settings are available in the "Measurement" dialog box.

Access: "Meas" menu > "Setup" > "Protocol" subtab

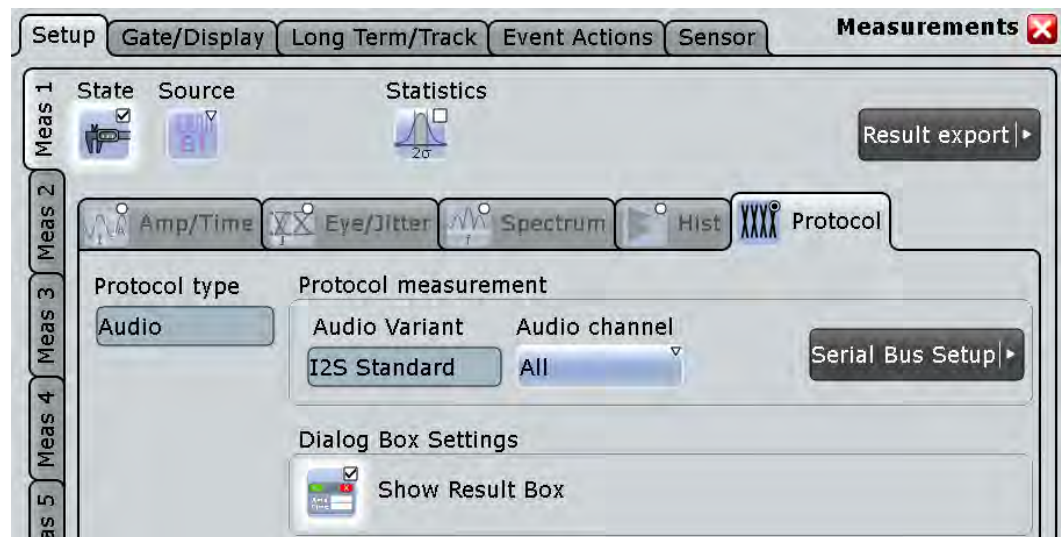

Protocol type, Audio variant

Show the current protocol settings for information

Audio channel

Selects the channel that is shown in the track and trend waveforms.

"All" displays all channels in one waveform.

Show Result Box

Hides or shows the measurement result box. For track and trend, no numerical results are available in the result box, so you can hide it.

Track Enabling in Measurement Setup

As the track is based on measurement, it can be set up in the "Long Term/Track" tab of the "Measurement" dialog box. Alternatively, you can enable the track in the protocol display settings, see ["Track Settings in Protocol Setup"](#) on page 504.

Access: "Meas" menu > "LongTerm/Track"

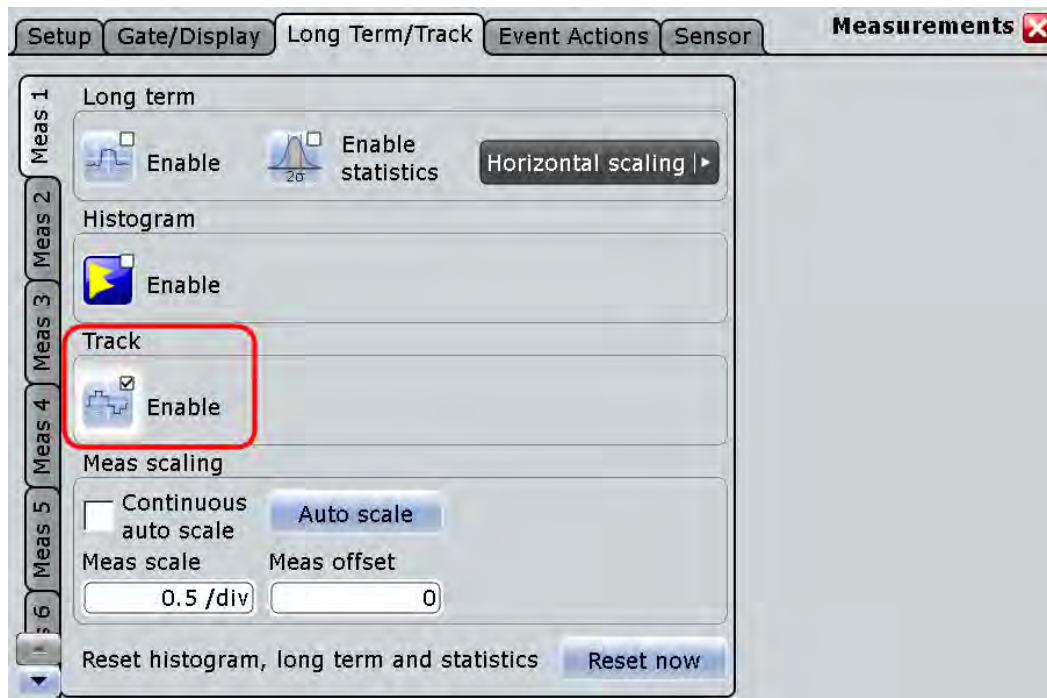

To set the vertical scale of the track waveform, use the measurement scale settings on "LongTerm/Track" tab, see ["Meas scaling"](#) on page 280.

Enable (Track)

Enables the track measurement and displays the track of the selected .

The track is available with the following applications:

- Option R&S RTO-K5 I²S Audio Signals
If this option is installed and decoding results of an audio bus are available, the track can be displayed for the selected [Audio channel](#).
See also: [chapter 14.8.5.1, "Track"](#), on page 502.
- Option R&S RTO-K12 Basic Jitter Analysis
If this option is installed, you can use tracks to display the jitter measurement results of an acquisition as a time-correlated waveform, see [chapter 17.1.5, "Track of Jitter Measurement Results"](#), on page 552.

Remote command:

`MEASurement<m>:TRACk[:STATe]` on page 840

14.8.5.2 Trend

The trend is a special long term measurement that shows the evolution of measurement values in a running continuous acquisitions. For audio signals, each decoded

channel value is a measurement result that creates a point on the trend curve. You can configure the number of points that builds the complete trend curve.

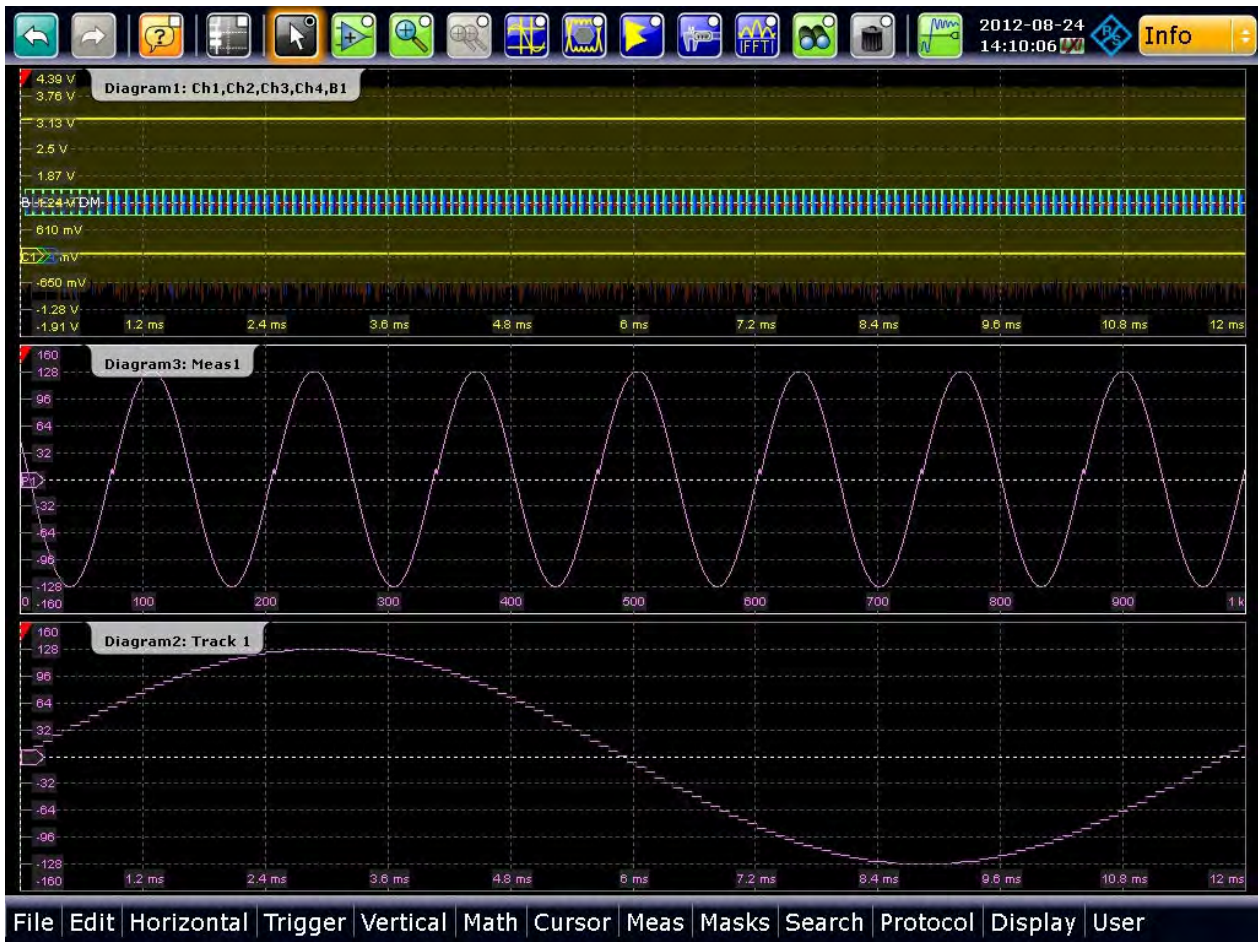
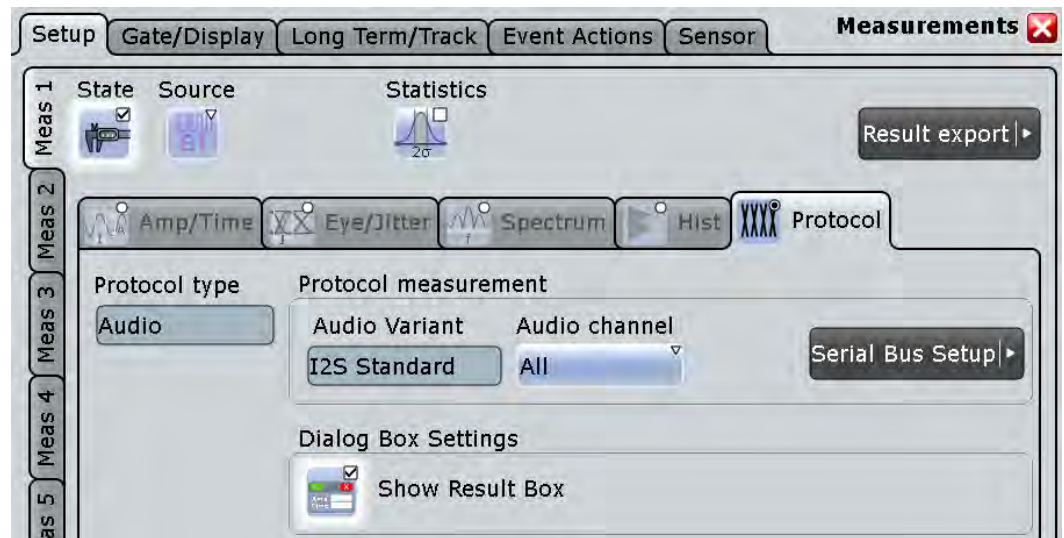

Fig. 14-25: Trend (Diagram3) and track of an audio signal

Displaying and Configuring the Trend

If an audio bus is configured, the MEAS key and the "Measurement" icon can identify the bus and preconfigure the measurement. The following procedure describes the complete trend setup using the "Meas" menu.

1. On the "Meas" menu, select "Setup".
2. Select the "Source" of the measurement: "Serial bus".
3. Select the "Audio channel" for which you want to analyze the trend.
4. Enable "State".



5. Select the "Long term/Track" tab.
6. Tap "Horizontal scaling".
7. Set the scale mode to "Measurements" and the number of "Measurements/point" to 1.

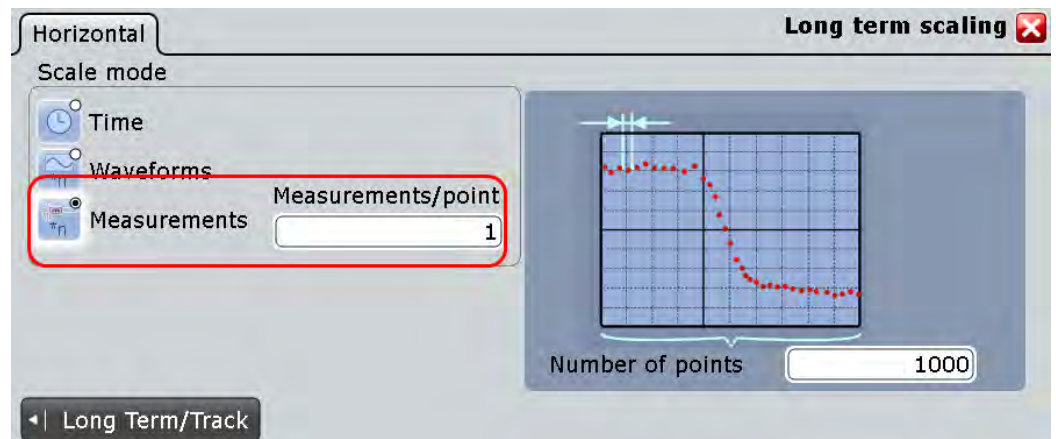

8. Tap "Long term/Track".
9. Set the "Vertical scaling" to "Continuous auto scale".
10. Under "Long term", select "Enable".

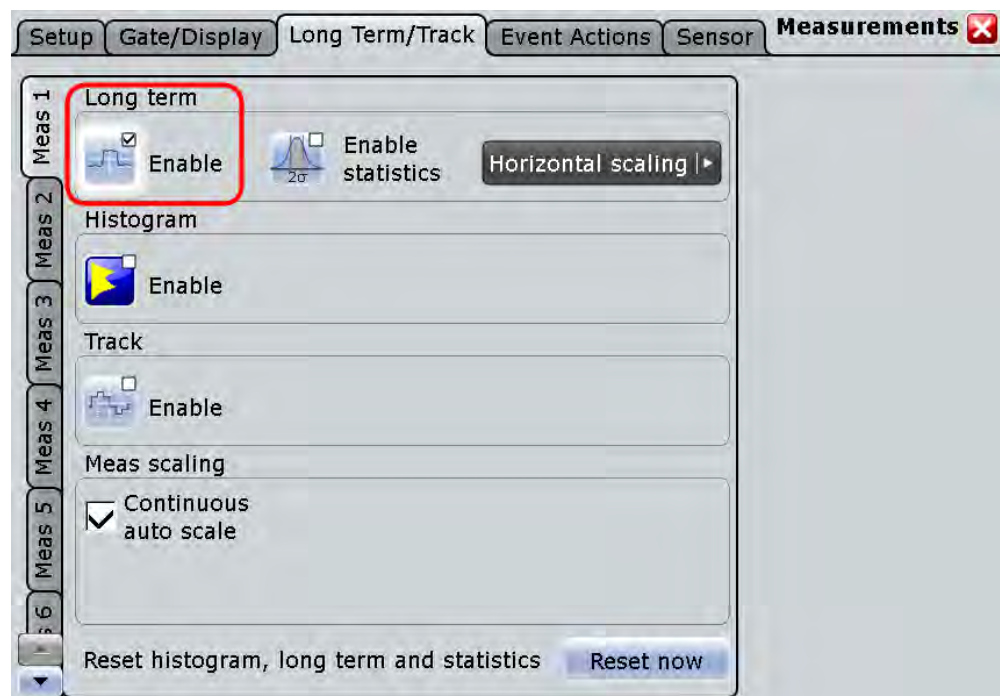

An empty trend diagram is displayed.

11. Start continuous acquisition.

The trend fills up with measurement points from left to right.

12. If you want to change the vertical scaling of the trend curve, disable "Continuous auto scale" and adjust "Vertical scale" and "Vertical offset".

15 Mixed Signal Option (MSO, R&S RTO-B1)

The Mixed Signal Option R&S RTO-B1 adds logic analyzer functions to the classical oscilloscope functions. Using the MSO option, you can analyze and debug embedded systems with mixed-signal designs that use analog signals and correlated digital signals simultaneously.

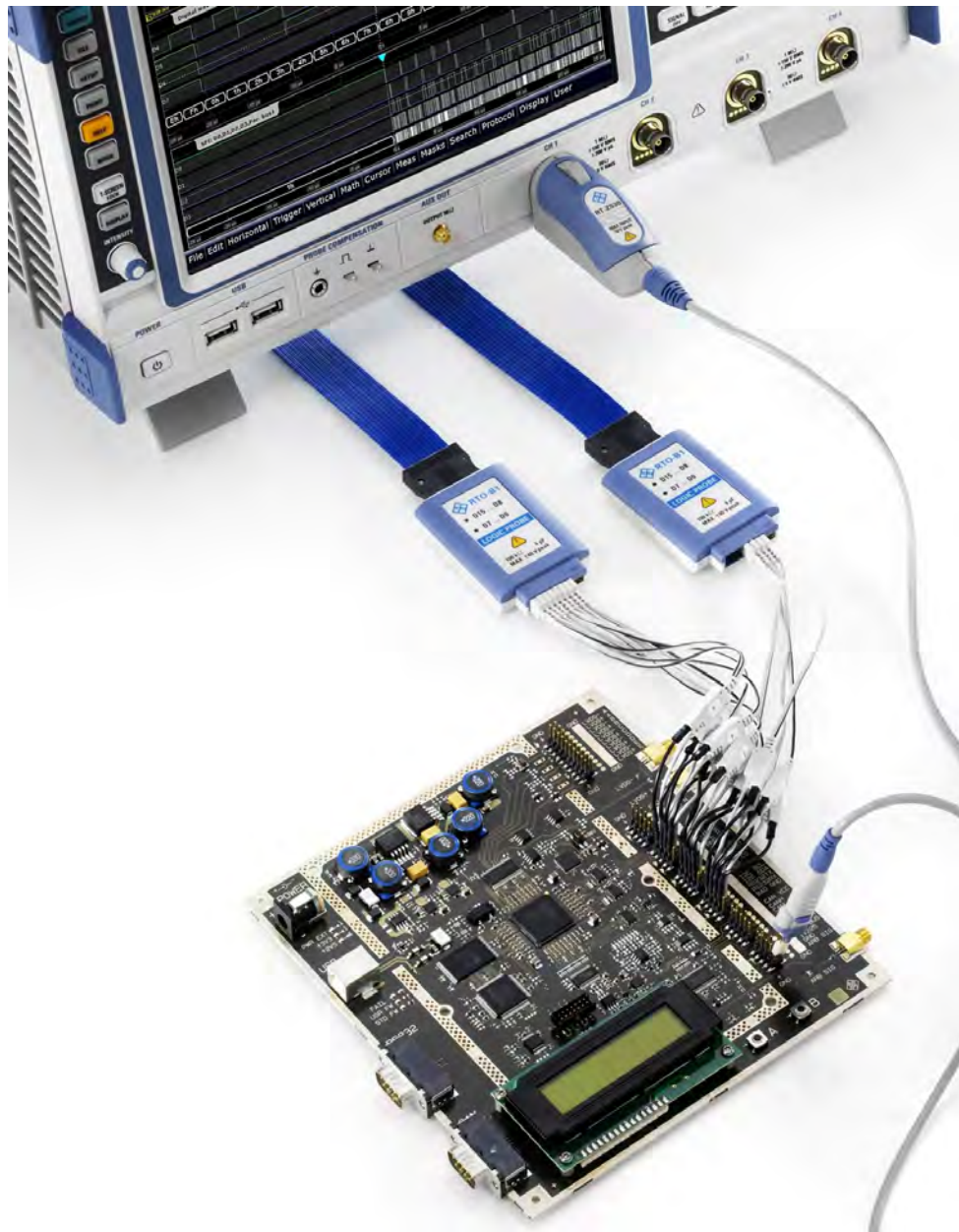

15.1 About MSO

The Mixed Signal Option provides 16 digital channels grouped in two logic probes (pods) with 8 channels each. The instrument ensures that analog and digital waveforms are time-aligned and synchronized so that critical timing interactions between analog and digital signals can be displayed and tested. The automatic alignment compensates the skew between the probe connectors of the analog channels and the probe boxes of the digital channels.

If digital channels are active, the equivalent-time sampling is not available.

Digital channels and parallel buses

Each digital channel can be displayed on the screen and used as trigger source. Digital channels may be grouped and displayed as a parallel bus. Up to four parallel buses can be configured; and two bus types are supported: clocked bus and unclocked bus. The clocked bus is available only on parallel bus 1 and 2. Each digital channel can be assigned to one *active* parallel bus only, the instrument disables conflicting buses automatically.

You can display each bus and use it as trigger source, as well. For each active parallel bus, the corresponding signal icon appears on the signal bar and indicates the assigned digital channels. Individual digital channels do not have a signal icon.

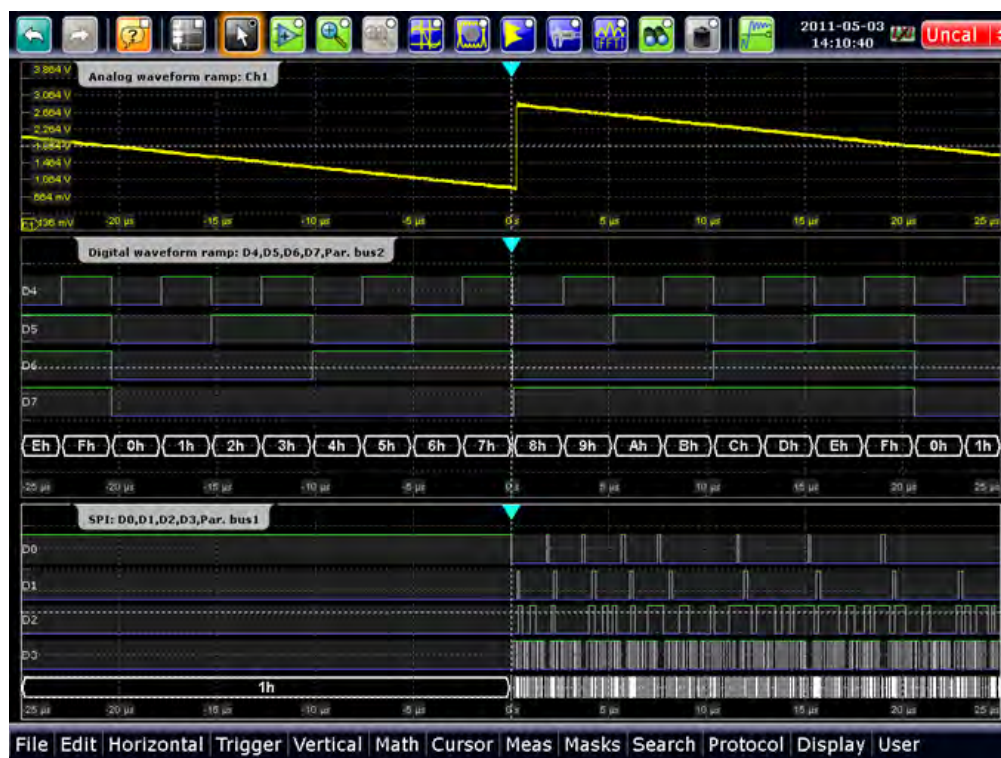

Display

You can adjust the display of the parallel bus signals and the individual digital channels to optimize the analysis of bus data:

- show the digital channels which are assigned to the bus, drag them to the optimal position, and scale them
- show the decoded bus signal in different ways:
 - comb display with numeric bus values
 - analog display with bus values as amplitudes (quasi-analog waveform)

You can also drag the bus waveforms on the display and scale them.

- show the result box of the decoded clocked bus signal

Each parallel bus is shown in a separate diagram, and the diagrams can be minimized and arranged as usual. The signal icon indicates the activities on the digital channels. See also: [chapter 15.2.4, "Adjusting the Display of Digital Channels and Parallel Buses"](#), on page 516.



The display update rate of the oscilloscope is adapted to the visual perception of human eyes, and it is slower than the acquisition rate. All analog and digital waveforms that are acquired during one display update cycle are overlapped and displayed at once. Thus you can see the cumulative occurrence of binary states and edge transitions on the screen at once. Bus signals are not overlapped. The trigger point is always visible on the display, it cannot be moved outside ("Restrict horizontal position to acquisition range" is enabled automatically).

To access and analyze one or more specific acquisitions, you can use the History Viewer in the common way.

Furthermore, you can zoom in digital signals and bus signal in the same way as in analog waveforms.

See also:

- [chapter 5.4, "History"](#), on page 207
- [chapter 5.2, "Zoom"](#), on page 193

Trigger possibilities

For digital trigger sources are all trigger types useful that require only one trigger level as trigger condition. This level is the logical threshold. Possible trigger sources are the individual digital channels, parallel bus signals, or any logical combination of digital channels. The following trigger types are available:

Table 15-1: Trigger types and digital trigger sources

Trigger type	Trigger source is		
	Digital channel	Logic combination of digital channels	Parallel bus
Edge	X	X	
Width	X	X	
Timeout	X	X	
Data2Clock	X		X
State		X	X
Pattern (with holdoff)		X	X
Serial Pattern	X	X	

For details, see: [chapter 15.3.5, "Trigger Settings for Digital Signals and Parallel Buses"](#), on page 524.

Additionally, you can define trigger holdoff conditions in the "Sequence" tab. See also: ["Holdoff mode"](#) on page 168.

Cursor Measurements

Cursor measurements can be performed on digital signals and *unclocked* parallel buses. In this case, only vertical cursor lines are used, and the corresponding time measurement results are displayed: t_1 , t_2 , Δt , and $1/\Delta t$. The instrument decodes the bus value at the cursor position and indicates it as Y-value.



Automatic Measurements

Several automatic time measurements can be performed on digital signals. As for all measurements, the instrument analyzes the type of the measurement source and displays only measurement types appropriate for the selected measurement source. If a digital channel is selected as measurement source, the positive pulse measurement (width of a positive pulse) is set as default measurement.

Statistical evaluation of time measurements and limit tests are also possible. The result of the limit test can initiate an action, for example, stopping the acquisition or saving the waveform.

Gating, eye/jitter measurements and histogram measurements on digital sources are not available.

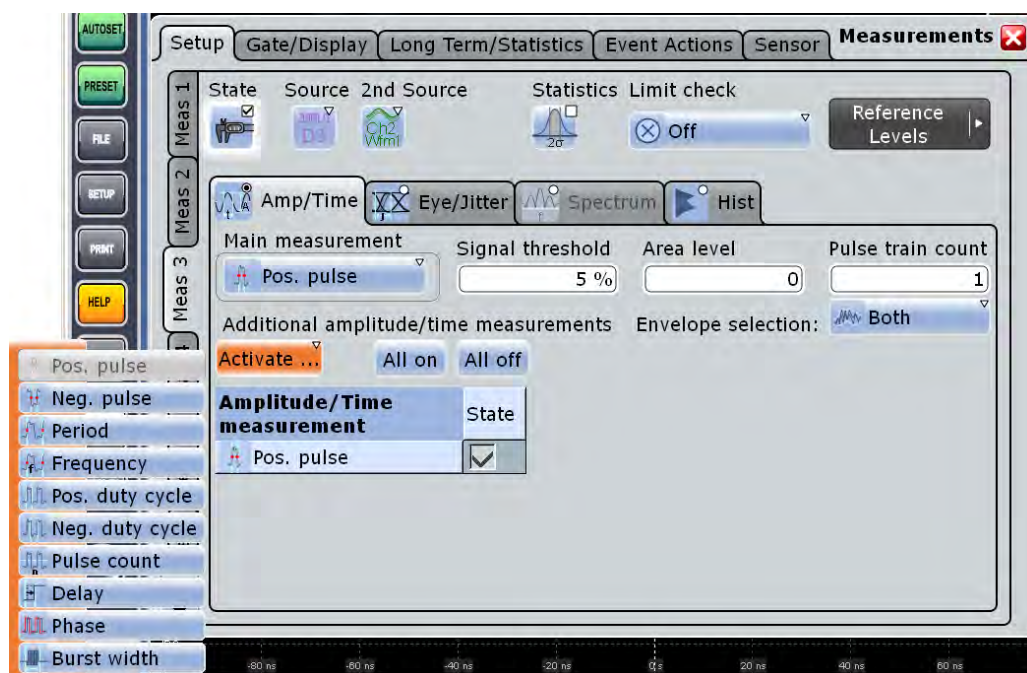

Fig. 15-1: Automatic measurements for digital signals

See also: ["Time Measurements"](#) on page 236.

Mathematics

A parallel bus that is displayed as quasi-analog waveform can be analyzed with FFT. To configure the FFT, use the "Advanced" mode and the formula editor.

Search

It is also possible to search on digital channels for specified conditions. Search condition use the same parameters as the trigger event definition. You can search for edge, width, timeout, and Data2Clock conditions.

Data export

The data of digital channels can be saved in the same way as analog waveform data. One source waveform per file can be saved.

If the data of digital channels is stored in BIN format, one bit is written for each sample. 8 data samples are written in one byte (data word). For example, 100 MSa are written into a 12.5 MByte BIN file. After reading the file, you have to extract the samples from the data words.

You can also export parallel bus data if the parallel bus is set to analog bus representation.

See also:

- [chapter 11.1.2, "Saving and Loading Waveform Data"](#), on page 361
- [chapter 11.2.2.2, "Waveforms - Export Settings"](#), on page 374

15.2 Analyzing Digital Signals

This chapter provides step-by-step procedures for working with the MSO R&S RTO-B1 option.

- [Using Digital Probes](#).....515
- [Configuring Digital Channels and Parallel Buses](#).....515
- [Setting the Logical Thresholds](#).....516
- [Adjusting the Display of Digital Channels and Parallel Buses](#).....516
- [Triggering on Digital Signals and Parallel Buses](#).....517
- [Performing Measurements on Digital Signals](#).....518

15.2.1 Using Digital Probes

Consider the following guidelines for good probing practices:

- The ground lead from each digital channel group (D15–D8 and D7–D0) should be attached to the ground of the device under test if any channel within the group is being used for data capture. The ground lead improves signal fidelity to the oscilloscope, ensuring accurate measurements.
 - For high-speed timing measurements (rise time < 3 ns), each digital channel probe should use its own ground.
1. Connect the digital probe cable to any of the MSO connectors on the rear panel of the instrument as shown on the Documentation Card delivered with the digital probe.
 2. Connect the ground lead on each set of channels (each pod) with a probe grabber.
 3. Connect a grabber to one of the probe leads.
 4. Connect the grabber to a node in the circuit you want to test.
 5. For high-speed signals, connect a ground lead to the probe lead, and connect the ground lead to ground in the device under test.
 6. Repeat these steps until you have connected all points of interest.

15.2.2 Configuring Digital Channels and Parallel Buses

The configuration of a parallel bus includes the selection and setup of the digital channels, the configuration of the bus display, and, if required, the clock configuration.

For a detailed description of the settings, see [chapter 15.3.1, "Parallel Buses - Configuration"](#), on page 518.

1. On the "Analysis" menu, tap "Parallel buses".
2. In the "State" column of the "Signal selection" table, enable the digital channels to be displayed and included in the bus.
To enable or disable all channels of a pod at once, tap "D0-D7" or "D8-D15".

Enabling one or more channels also enables the display of the signals - "Show dig. signals", and enables the parallel bus. If another active bus already uses the same digital channel(s), the instrument disables this bus and shows a message.

The digital signals are shown in the diagram, and the signal icon of the parallel bus appears on the signal bar. Using this bus icon, you can minimize, arrange, and switch off the bus together with its channels in the same way as you do with any waveform.

3. Optionally, you can enter a "Label" for each digital channel, and a "Deskew" value to time-align the channel.
4. Set the logical thresholds as described in [chapter 15.2.3, "Setting the Logical Thresholds"](#), on page 516.
5. If the bus has a clock signal, enable "Bus clocked" and select the "Clock source" and "Clock slope".

Now the configuration of the parallel bus is completed.

15.2.3 Setting the Logical Thresholds

For a detailed description of the settings, see ["Threshold setup"](#) on page 522. Threshold settings are the same for all *active* parallel buses.

1. On the "Analysis" menu, tap "Parallel buses".
2. To set the thresholds, use one of the following ways:
 - Use the same value for all digital channels and all parallel buses: Enable "Coupling" and set one threshold value, either select a predefined "Technology" value or enter a user-defined value.
 - Set different thresholds for the individual channel groups: Disable "Coupling" and set the threshold value for each group. As long as the buses are disabled, you can set different thresholds for each bus. Active buses use the same threshold and hysteresis values.
3. Set the "Hysteresis" for each threshold to avoid the change of signal states due to noise.

15.2.4 Adjusting the Display of Digital Channels and Parallel Buses

The display of digital channels and parallel buses is flexible, you can adjust it to your needs by combining the following settings:



1. Enable "Show bus" if you want to display the bus signal in the diagram. Under "Bus representation", select if you want to display the decoded bus signal with bus values ("Comb"), or show the bus values as amplitudes, similar to an analog waveform ("Analog").

2. Check the signal icon of the bus to monitor the activities on the digital channels even if they are not displayed in the diagram, or if the acquisition has been stopped:
 - blue: channel is low
 - green: channel is high
 - gray: channel state is changing
3. In the diagram, you can change the display order of the digital channels by dragging the individual channels to the required position.
4. To adjust the line height and vertical position of all digital channels at once, tap one of the digital channels and turn the vertical SCALE and POSITION rotary knobs. In the same way, you can move and scale the bus signal.
5. If the bus signal is displayed as quasi-analog waveform, you can double-tap the waveform to open the "Parallel buses" dialog box.
6. To switch off the display of the digital channels, disable "Show signals".



15.2.5 Triggering on Digital Signals and Parallel Buses

For a detailed description of the settings, see [chapter 15.3.5, "Trigger Settings for Digital Signals and Parallel Buses"](#), on page 524.

1. Press the TRIGGER key and select the "Events" tab.
2. Select the trigger "Source":
 - one of the digital channels "D0" ... "D15"



 - a logic combination of digital channels: "Logic"

 - one of the parallel buses "Par. bus1" ... "Par. bus4"



3. Select the trigger "Type".
4. Under "Trigger type dependent settings", configure the trigger.
5. For trigger source "Logic", enter the logical expression of the digital channel combination. Tap and hold the "Logical expression" field until the "Qualification Editor" opens. It provides all logic operators that can be used in the expression.



15.2.6 Performing Measurements on Digital Signals

Measurements on digital signals are performed in the same way as measurements on analog waveforms. For digital signals, only time measurements are useful. If a digital channel is selected as measurement source, the instrument sets the positive pulse measurement as main measurement and provides only the appropriate time measurement types for selection.

For detailed procedures, see:

- [chapter 7.2.3.1, "Starting an Automatic Measurement"](#), on page 253
- [chapter 7.2.3.2, "Configuring Measurements"](#), on page 254
- [chapter 7.2.3.6, "Using Gate Areas"](#), on page 258
- [chapter 7.2.3.8, "Compiling Measurement Statistics"](#), on page 259

15.3 Reference for MSO

- [Parallel Buses - Configuration](#).....518
- [Parallel Buses - Digital Probes](#).....523
- [Parallel Bus - Decode Table](#)..... 523
- [Digital Resolution](#)..... 524
- [Trigger Settings for Digital Signals and Parallel Buses](#).....524

15.3.1 Parallel Buses - Configuration

Access: "Analysis" menu > "Parallel buses"

Digital channels can be displayed individually, and they can be grouped and displayed as a parallel bus. You can configure and enable up to 4 parallel buses. Each digital channel can be assigned to one *active* parallel bus only, the instrument disables conflicting buses automatically.

For clocked buses, you can display the decoding results in a result box.

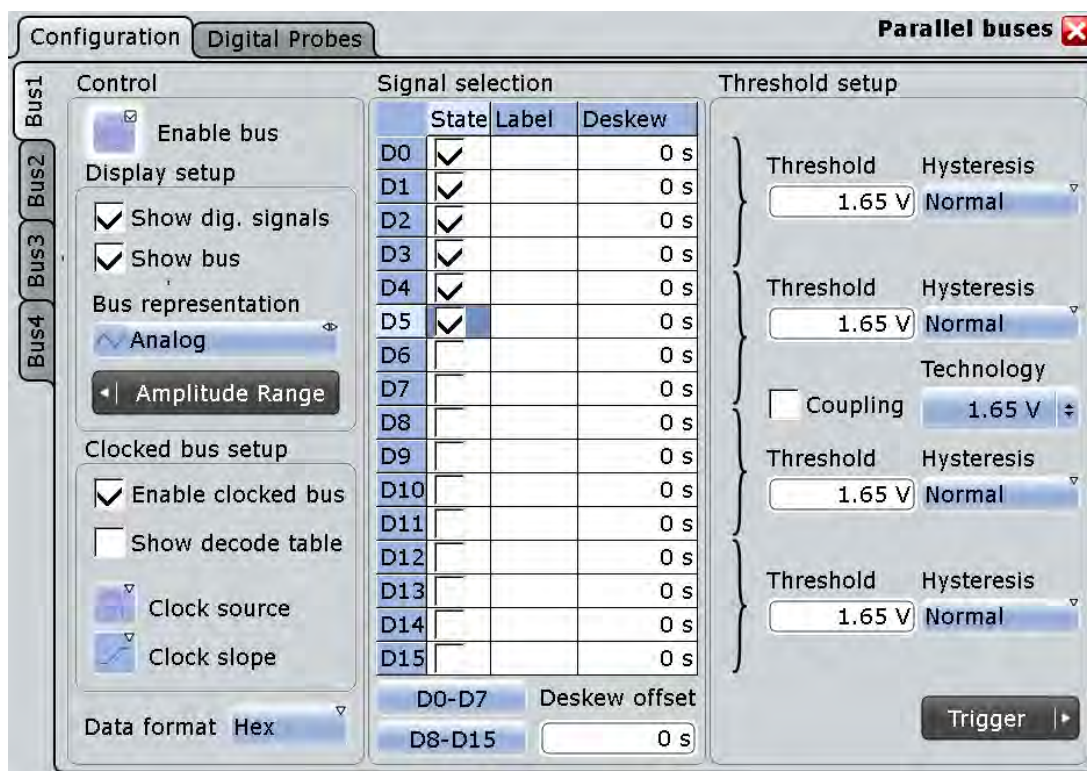

If you have configured several parallel buses and you want to modify the configuration or display settings, make sure that the tab of the correct bus is selected on the left side, and disable the bus before you change the settings.

- Enable bus..... 519
- Show dig. signals..... 520
- Show bus..... 520
- Bus representation..... 520
- Amplitude Range..... 520
- Clocked bus setup..... 521
- Data format..... 521
- Signal selection..... 521
 - └ D0-D7, D8-D15..... 522
 - └ Deskew offset..... 522
- Threshold setup..... 522

Enable bus

Enables the selected parallel bus. The corresponding signal icon appears on the signal bar.

If another *active* bus already uses the same digital channel(s), the instrument disables the other bus and shows a message.

Remote command:

BUS<m>:PARAllel:STATe on page 1052

Show dig. signals

If enabled, the selected digital channels are shown in the diagram. Each channel is displayed as a logic signal.

Remote command:

`BUS<m>:PARAllel:DISPlay:SHDI` on page 1056

Show bus

If enabled, the resulting bus signal and bus values are displayed in the diagram. Select the presentation type for the bus signal with [Bus representation](#).

Remote command:

`BUS<m>:PARAllel:DISPlay:SHBU` on page 1056

Bus representation

Defines how the parallel bus is displayed:

"Comb" Displays the decoded bus signal with bus values. When at least one digital channel changes its value, the bus value changes too.

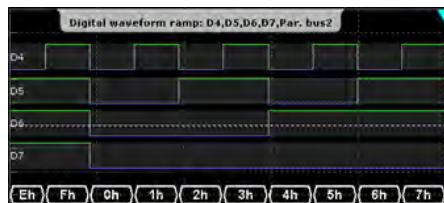

"Analog" Displays the bus values as signal amplitudes, similar to an analog waveform. Thus, a quasi-analog waveform is created.

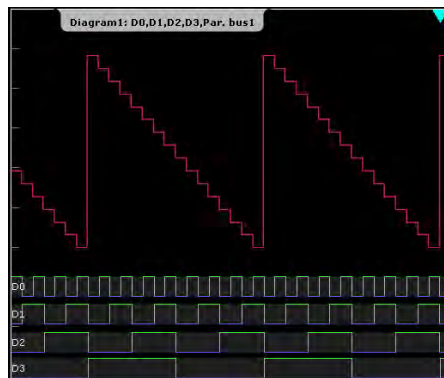

Remote command:

`BUS<m>:PARAllel:DISPlay:BTYP` on page 1056

Amplitude Range

If the bus representation is "Analog", the amplitude range defines the voltage range for the display of the analog bus. The highest bus value corresponds to the "Maximum voltage", and the lowest bus value to the "Minimum voltage".

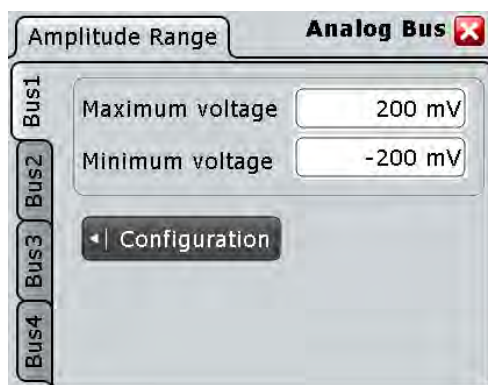

See also: ["Bus representation"](#) on page 520

Clocked bus setup

If a bus is a clocked bus, one of the digital channels serves as clock of the bus.

For an unclocked bus, the logical state of the bus is determined for each sample. For a clocked bus, the logical state is determined only at the specified clock edges.

The settings are only available for "Bus1" and "Bus2".

"Enable clocked bus" Enable this option, if the bus is a clocked bus.

"Show decode table" The decode table is only available for clocked buses to check the data words. If enabled, a results box opens with decoded values of the bus signal and its time. Each clock edge corresponds to one row in the table.

"Clock source" Selects the digital channel used as clock.

"Clock slope" Selects the slope of the clock signal at which all digital channels of the bus are analyzed.

Remote command:

[BUS<m>:PARallel:CLON](#) on page 1057

[BUS<m>:PARallel:CLOCK](#) on page 1057

[BUS<m>:PARallel:CLSLope](#) on page 1057

Data format

Sets the data format of bus values, which are displayed in the result box and on the comb bus display. Available formats are: Hex, Ascii, Octal, Binary, Signed, and Unsigned.

Signed and Unsigned are integer data types with maximum 16 bit length. Unsigned is used for positive integers. Signed is used for positive and negative integers.

Signal selection

In the table, you select and configure the digital channels that are used in the selected bus.

"State" Enables a digital channel, and assigns it to the bus.

"Label" You can enter a name for each digital channel. The name is displayed in the diagram.

"Deskew" Sets an individual delay for each digital channel to time-align it with other digital channels. The deskew value compensates delays that are known from the circuit specifics or caused by the different length of cables. The skew between the probe boxes of the digital channels and the probe connectors of the analog channels is automatically aligned by the instrument. You can also set a value that is applied to all digital channels, see "Deskew offset" on page 522.

Remote command:

`BUS<m>:PARAllel:BIT<n>[:STATe]` on page 1052 (all buses)

`DIGital<m>:DISPlay` on page 1048 (Bus1)

`BUS<m>:PARAllel:BIT<n>:LABel` on page 1055 (all buses)

`DIGital<m>:LABel` on page 1051 (Bus1)

`BUS<m>:PARAllel:BIT<n>:DESKew` on page 1055 (all buses)

`DIGital<m>:DESKew` on page 1051 (Bus1)

D0-D7, D8-D15 ← Signal selection

The buttons select or deselect all digital channels of a pod at once.

Deskew offset ← Signal selection

Sets a general delay for all digital channels. The resulting deskew of a digital channel is the sum of the general "Deskew offset" and the individual "Deskew".

Remote command:

`BUS<m>:PARAllel:DESoffset` on page 1055

Threshold setup

Sets the logical threshold. For each sample, the instrument compares the input voltage with the threshold value. If the input voltage is above the threshold, the signal state "1" is stored. Otherwise, the signal state "0" is stored if the input voltage is below the threshold.

To avoid the change of signal states due to noise, a hysteresis is considered.

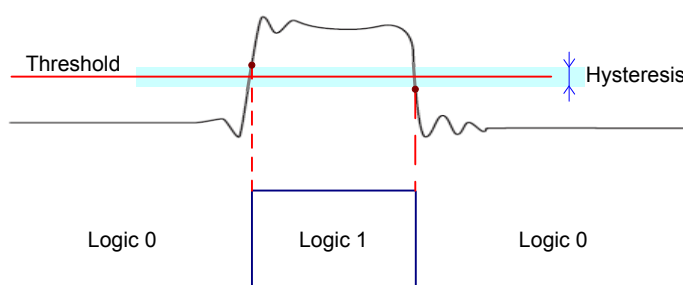

By default, same threshold and hysteresis value is used for all digital channels and all parallel buses: "Coupling" is enabled.

You can also set different thresholds for the individual channel groups: Disable "Coupling" and set the threshold value for each group. As long as the buses are disabled, you can set different thresholds for each bus. Active buses use the same threshold and hysteresis values, the settings of the last activated bus take effect.

The range of threshold levels and the minimum voltage swing are given in the data sheet.

"Threshold"	Enter the value directly in the field.
"Technology"	Selects the threshold voltage for various types of integrated circuits from a list and applies it to all digital channels. The value is set to "Manual" if a user-defined threshold was entered directly.
"Coupling"	Sets the threshold and the hysteresis for all digital channels and all buses to the same value.
"Hysteresis"	Defines the size of the hysteresis. Three values are available: <ul style="list-style-type: none"> • Normal: the instrument sets a small value suitable for the signal and its settings. Use this setting for clean signals. • Maximum: the instrument sets the maximum value that is possible and useful for the signal and its settings. Use this setting for noisy signals. • Robust: sets different hysteresis values for falling and rising edges to avoid an undefined state of the trigger system. Use this setting for very noisy signals. For details, see "Robust trigger" on page 141.

Remote command:

[BUS<m>:PARAllel:TECHnology](#) on page 1053 (all buses)

[DIGital<m>:TECHnology](#) on page 1049 (bus1)

[BUS<m>:PARAllel:THReshold<n>](#) on page 1052 (all buses)

[DIGital<m>:THReshold](#) on page 1049 (bus1)

[BUS<m>:PARAllel:THCoupling](#) on page 1054 (all buses)

[DIGital<m>:THCoupling](#) on page 1050 (bus1)

[BUS<m>:PARAllel:HYSTeresis<n>](#) on page 1054 (all buses)

[DIGital<m>:HYSTeresis](#) on page 1050 (bus1)

15.3.2 Parallel Buses - Digital Probes

Access: "Analysis" menu > "Parallel buses" > "Digital Probes" tab

Logic probes provided by R&S are recognized by the instrument. The fields show the characteristics of each recognized probe (pod) for information. "Write EEPROM" and "Flash it" are service functions.

15.3.3 Parallel Bus - Decode Table

The decode table shows the decoded values of the bus signal and the according time. Each clock edge corresponds to one row in the table. Below the table, you can select the data format of the bus values. Decoding is available for clocked buses to check the data words.

The results can be saved to a csv or html file, see [chapter 11.2.2.4, "Numeric Results"](#), on page 381.

15.3.4 Digital Resolution

Access: RES / REC LEN key

If an MSO option is installed and at least one digital channel is active, additional information appears on the "Resolution" tab of the "Horizontal" dialog box.

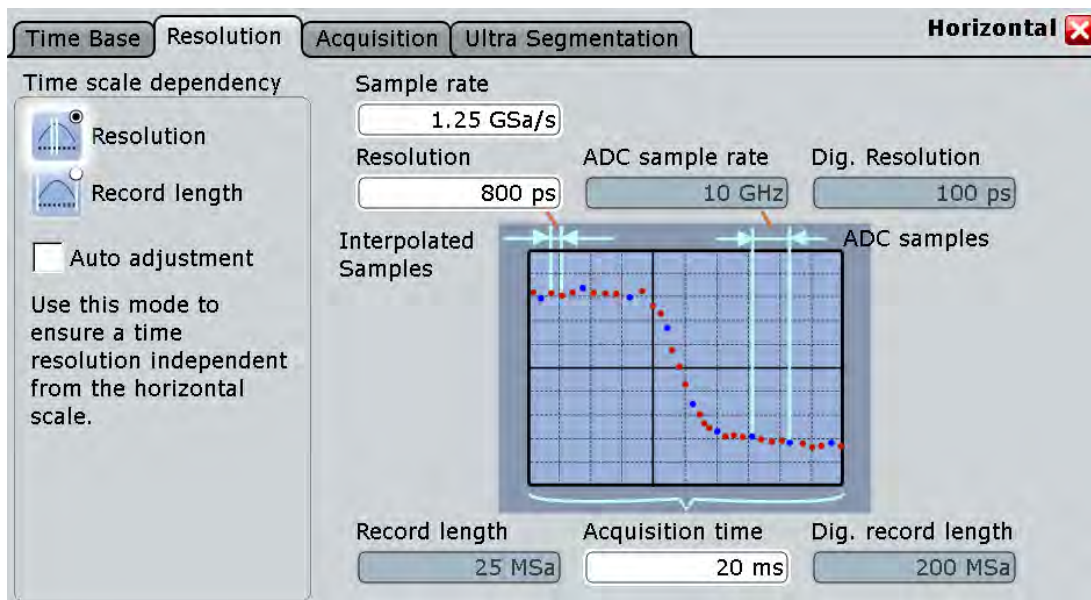

Dig. resolution, Dig. record length

The parameter show the current digital record length used by each digital channel, and the digital resolution of the digital channels. The maximum digital record length is always 200 MSa per digital channel. This number is independent of additionally installed memory.

If [Auto adjustment \(Time scale dependency\)](#) is enabled, the digital record length is the same as the record length of analog channels. If "Auto adjustment" is disabled, increasing the acquisition time increases the digital record length independently of the record length of analog channels until the maximum is reached, and the digital resolution remains constant. Further increase of the acquisition time impairs the digital resolution, it increases, too.

15.3.5 Trigger Settings for Digital Signals and Parallel Buses

Depending on the selected source, the instrument provides the appropriate trigger types and the corresponding trigger settings.

The settings in the "Event" tab are:

- [Basic Trigger Settings](#)..... 525
- [Edge](#)..... 526
- [Width](#)..... 526
- [Timeout](#)..... 528
- [Data2Clock](#)..... 529

- [State](#).....530
- [Pattern](#).....531
- [Serial Pattern](#).....534

15.3.5.1 Basic Trigger Settings

The basic trigger settings for MSO are the trigger source and the trigger type. They are selected in the upper part of the "Trigger" dialog box.









Make sure that the trigger sequence is set to "A only".

Additionally, you can define trigger holdoff conditions in the "Sequence" tab. See also: "[Holdoff mode](#)" on page 168.

Source

If the Mixed Signal Option is installed, the variety of trigger sources of the A-event setup is enhanced with specific digital trigger sources. You can select as trigger source:

- one of the digital channels "D0" ... "D15"
 - 
 - 
 - 
- a logic combination of digital channels: "Logic"
 - 
- one of the parallel buses "Par. bus1" ... "Par. bus4"
 - 
 - 
 - 

Remote command:

`TRIGger<m>:SOURce` on page 702

Type

Depending on the selected source, the instrument provides the appropriate trigger types and the corresponding trigger settings. For mixed signal analysis, the following trigger types are available:

- [Edge](#), see page 526
- [Width](#), see page 526
- [Timeout](#), see page 528
- [Data2Clock](#), see page 529
- [State](#), see page 530
- [Pattern](#), see page 531
- [Serial Pattern](#), see page 534

Remote command:

`TRIGger<m>:PARallel:TYPE` on page 1059

15.3.5.2 Edge

Using the edge trigger, you can also trigger on a single digital channel (a logic bit), and a logical combination of digital channels.

Depending on the selected trigger source, different trigger settings are available. The trigger level is already set - in MSO the logical threshold is used as trigger level.

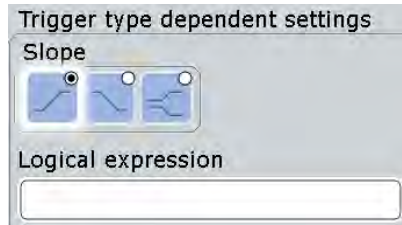

Fig. 15-2: Edge trigger settings for trigger source = logical combination of digital channels (Logic)

Slope

Defines the edge - the state transition - of the signal.

"Rising" Means a 0 to 1 transition of the state.

"Falling" Means a 1 to 0 transition of the state.

"Either" Triggers on any activity on the selected trigger source.

Remote command:

[TRIGger<m>:PARallel:EDGE:SLOPe](#) on page 1060

Logical expression

Defines a logical combination of several digital channels as trigger condition if "Logic" is set for "Source". If the "Slope" is rising, the trigger occurs when the logical expression comes true. If the "Slope" is falling, the trigger occurs when the logical expression comes false.

Remote command:

[TRIGger<m>:PARallel:EDGE:EXPReSSion\[:DEFine\]](#) on page 1060

15.3.5.3 Width

The width trigger detects positive and/or negative pulses of a pulse width (duration) inside or outside of a defined time limit. It can trigger on a single digital channel or a logical combination of digital channels.

The instrument triggers at the end of the detected pulse.

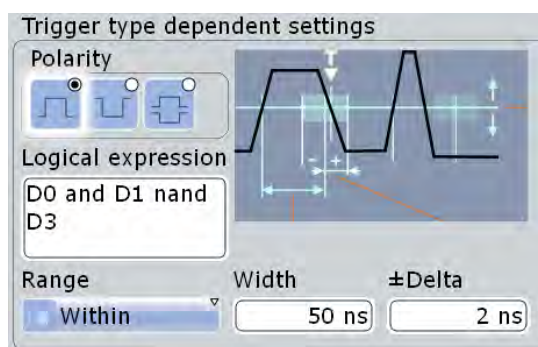

Fig. 15-3: Width trigger settings for trigger source = logical combination of digital channels

Range

Selects how the range of a pulse width is defined:

- "Within" Triggers on pulses inside a given time range. The time limit is defined by $Width \pm Delta$.
- "Outside" Triggers on pulses shorter or longer than a given time range. The time limit definition is the same as for "Within" range.
- "Shorter" Triggers on pulses shorter than the given "Width".
- "Longer" Triggers on pulses longer than the given "Width".

Remote command:

[TRIGger<m>:PARallel:WIDTh:RANGe](#) on page 1061

Width

For the ranges "Shorter" and "Longer", the width defines the maximum and minimum pulse width, respectively.

For the ranges "Within" and "Outside", the width defines the center of a range which is defined by the limits $\pm Delta$.

Remote command:

[TRIGger<m>:PARallel:WIDTh:WIDTh](#) on page 1061

$\pm Delta$

Defines a range around the given width value.

The combination "Range" = Within and $\pm Delta$ = 0 triggers on pulses with a pulse width that equals "Width".

The combination "Range" = Outside and $\pm Delta$ = 0 means to trigger on pulse widths \neq "Width".

Remote command:

[TRIGger<m>:PARallel:WIDTh:DELTA](#) on page 1062

Polarity

Sets the polarity of a pulse to "Positive", "Negative", or "Both".

When triggering on a positive pulse, the trigger event occurs on the high to low transition of the pulse if the timing condition is true. When triggering on a negative pulse, the trigger event occurs on the low to high transition of the pulse if the timing condition is true.

Remote command:

`TRIGger<m>:PARAllel:WIDTh:POLarity` on page 1061

Logical expression

Defines a logical combination of several digital channels as trigger condition if "Logic" is set for "Source". As long as the digital signals match the logical expression (true), the pulse is positive. Otherwise, the pulse is negative.

Remote command:

`TRIGger<m>:PARAllel:WIDTh:EXPReSSion[:DEFine]` on page 1060

15.3.5.4 Timeout

The timeout trigger event checks if the trigger source signal stays above or below the threshold voltage for a specified time lapse. In other words, the event occurs if the state condition remains unchanged for the specified time.

You can use the timeout trigger on a single digital channel, or a logical combination of digital channels.

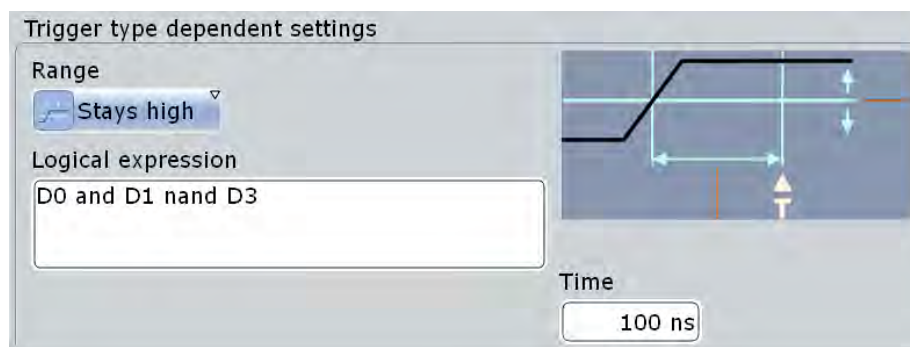

Fig. 15-4: Timeout trigger settings for trigger source = logical combination of digital channels

Range

Sets the state condition:

- "Stays high" The level of a digital channel stays above the threshold, or the logical expression for "Logic" trigger source is true.
- "Stays low" The level of a digital channel stays below the threshold, or the logical expression for "Logic" trigger source is false.
- "High or low" The signal state remains unchanged.

Remote command:

`TRIGger<m>:PARAllel:TIMEout:RANGe` on page 1062

Time

Defines the time limit for the timeout at which the instrument triggers.

Remote command:

[TRIGger<m>:PARAllel:TIMEout:TIME](#) on page 1063

Logical expression

Defines a logic combination of several digital channels as trigger condition if "Logic" is set for "Source". The "Qualification Editor" supports the entry of the expression.

Remote command:

[TRIGger<m>:PARAllel:TIMEout:EXPRession\[:DEFine\]](#) on page 1060

[TRIGger<m>:PARAllel:STATe:EXPRession\[:DEFine\]](#) on page 1060

[TRIGger<m>:PARAllel:PATTern:EXPRession\[:DEFine\]](#) on page 1060

[TRIGger<m>:PARAllel:SPATTern:EXPRession\[:DEFine\]](#) on page 1060

15.3.5.5 Data2Clock

The Data2Clock trigger event occurs when the state of the trigger source signal changes inside a given time before the clock edge (setup time) or after the clock edge (hold time). This trigger type is also known as setup/hold trigger. The trigger event occurs at the clock edge for which the setup and/or hold time was violated.

With Data2Clock trigger, you can trigger on a single digital channel, or a parallel bus to check several digital channels simultaneously. The clock signal is connected to one of the digital channels.

If you configure this trigger type for a parallel bus, the bus configuration is adjusted by the instrument if necessary. The bus is defined as clocked bus, and the clock source of the trigger is set as clock source of the bus.

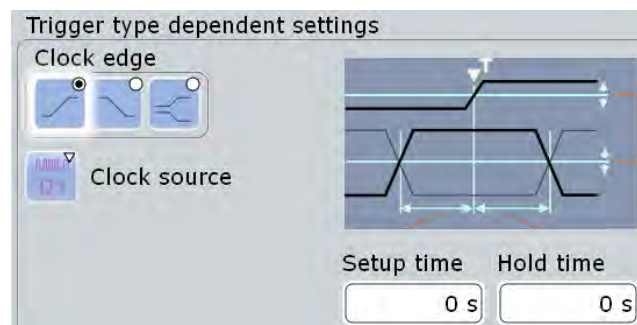

Fig. 15-5: Data2clock trigger settings

Clock source

Selects the digital channel of the clock signal.

Remote command:

[TRIGger<m>:PARAllel:DATatoclock:CSourc\[:VALue\]](#) on page 1059

[TRIGger<m>:PARAllel:STATe:CSourc:VALue](#) on page 1059

[TRIGger<m>:PARAllel:SPATTern:CSourc\[:VALue\]](#) on page 1059

Clock edge

Sets the edge of the clock signal. The crossing of the clock edge and the logical threshold defines the time reference point for the setup and hold time measurement.

Remote command:

[TRIGger<m>:PARAllel:DATatoclock:CSOURCE:EDGE](#) on page 1063

Setup time

Sets the minimum time *before* the clock edge while data should be stable and not change its state.

The setup time can be negative. In this case, the setup interval starts after the clock edge, and the hold time starts after the setup time has expired. Thus, the hold time is always positive. If you change the negative setup time, the hold time is adjusted by the instrument.

Remote command:

[TRIGger<m>:PARAllel:DATatoclock:STIME](#) on page 1064

Hold time

Sets the minimum time *after* the clock edge while data should be stable and not change its state.

The hold time can be negative. In this case, the hold time ends before the clock edge, and the setup interval ends when the hold interval starts. Thus, the setup time is always positive. If you change the negative hold time, the setup time is adjusted by the instrument.

Remote command:

[TRIGger<m>:PARAllel:DATatoclock:HTIME](#) on page 1064

15.3.5.6 State

The state trigger detects the logical state of several logically combined digital channels at a given clock edge. The trigger source is a logical combination of digital channels or a parallel bus. The trigger occurs at the clock edge at which the state condition is true.

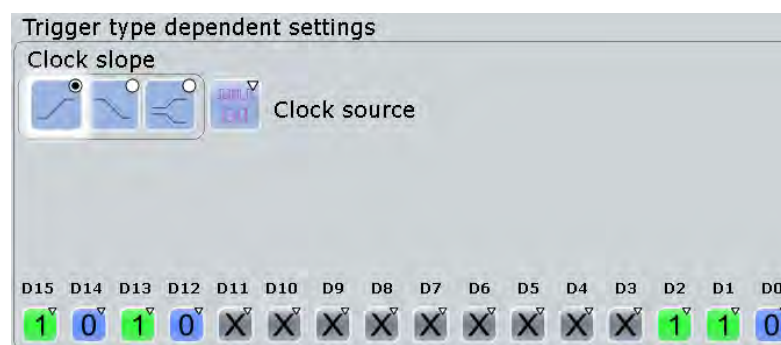

Fig. 15-6: State trigger settings for trigger source = parallel bus

Clock source

Selects the digital channel of the clock signal.

Remote command:

`TRIGger<m>:PARAllel:DATatoclock:CSOurce[:VALue]` on page 1059

`TRIGger<m>:PARAllel:STATe:CSOurce:VALue` on page 1059

`TRIGger<m>:PARAllel:SPATtern:CSOurce[:VALue]` on page 1059

Clock edge

Sets the edge of the clock signal. The crossing of the clock edge and the logical threshold defines the time at which the logical states and the bus value are analyzed.

Remote command:

`TRIGger<m>:PARAllel:STATe:CSOurce:EDGE` on page 1064

Channel states

For each digital channel that is used in the bus, set the required state: 1, 0, or X (don't care).

Remote command:

`TRIGger<m>:PARAllel:STATe:BIT<n>` on page 1065

Logical expression

Defines a logic combination of several digital channels as trigger condition if "Logic" is set for "Source". The "Qualification Editor" supports the entry of the expression.

Remote command:

`TRIGger<m>:PARAllel:TIMEout:EXPRession[:DEFine]` on page 1060

`TRIGger<m>:PARAllel:STATe:EXPRession[:DEFine]` on page 1060

`TRIGger<m>:PARAllel:PATTern:EXPRession[:DEFine]` on page 1060

`TRIGger<m>:PARAllel:SPATtern:EXPRession[:DEFine]` on page 1060

15.3.5.7 Pattern

The pattern trigger identifies a logical state of several logically combined digital channels (pattern) and a time limitation (holdoff). The pattern definition is defined by the logical expression, if "Logic" is used for trigger source. For a parallel bus trigger source, the pattern is defined by setting the state of each digital channel.

The timing starts when the pattern comes true. The decision level is the logical threshold.

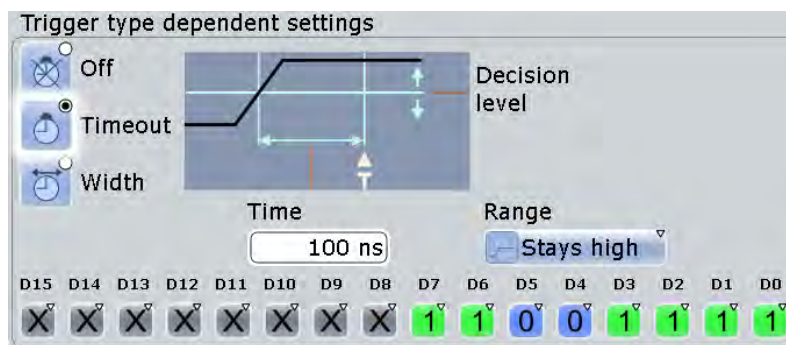

Fig. 15-7: Pattern trigger settings for trigger source = parallel bus and timeout

Channel states

For each digital channel that is used in the bus, set the required state: 1, 0, or X (don't care).

Remote command:

[TRIGger<m>:PARAllel:PATtern:BIT<n>](#) on page 1065

Logical expression

Defines a logic combination of several digital channels as trigger condition if "Logic" is set for "Source". The "Qualification Editor" supports the entry of the expression.

Remote command:

[TRIGger<m>:PARAllel:TIMEout:EXPReSSion\[:DEFine\]](#) on page 1060

[TRIGger<m>:PARAllel:STATe:EXPReSSion\[:DEFine\]](#) on page 1060

[TRIGger<m>:PARAllel:PATtern:EXPReSSion\[:DEFine\]](#) on page 1060

[TRIGger<m>:PARAllel:SPATtern:EXPReSSion\[:DEFine\]](#) on page 1060

Timing mode: Off, Timeout, Width

Sets the mode of the timing condition.

"Off" No timing condition, only the logical pattern condition is relevant.

"Timeout" Defines a minimum time qualification to avoid triggering on unstable or transitional conditions. Even in best-designed systems, there are slight delays between the signal when digital signals change states. This means that there are always transitional state conditions when signals are switching.
See ["Timeout settings"](#) on page 533 for a description of the settings. The trigger event occurs when the pattern stays unchanged for the specified time.

"Width" Sets a pulse width as timing condition, see ["Width settings"](#) on page 533. The pulse starts when the pattern comes true, and the trigger event occurs when the pattern comes false during the specified time limit.
Using this mode, you can, for example, trigger exclusively on unstable conditions - if the pattern is present for less than a specified time.

Remote command:

[TRIGger<m>:PARAllel:PATtern:MODE](#) on page 1065

Timeout settings

The timeout settings "Range" and "Time" appear if the timing mode is set to "Timeout".

Range ← Timeout settings

Sets the state condition:

- "Stays high" The pattern stays true for the specified time.
- "Stays low" The pattern stays false for the specified time.
- "High or low" The pattern remains unchanged for the specified time.

Remote command:

[TRIGger<m>:PARallel:PATtern:TIMEout:MODE](#) on page 1066

Time ← Timeout settings

Defines the time limit for the timeout at which the instrument triggers.

Remote command:

[TRIGger<m>:PARallel:PATtern:TIMEout\[:TIME\]](#) on page 1066

Width settings

The width settings "Range", "Width" and "±Delta" appear if the timing mode is set to "Width".

Range ← Width settings

Selects how the range of a pulse width is defined:

- "Within" Triggers when the pattern comes false inside a given time range. The time limit is defined by *Width ± Delta*.
- "Outside" Triggers when the pattern comes false before or after the given time range. The time limit definition is the same as for "Within" range.
- "Shorter" Triggers when the pattern comes false before the given "Width" has expired.
- "Longer" Triggers when the pattern comes false after the given "Width" has expired..

Remote command:

[TRIGger<m>:PARallel:PATtern:WIDTH:RANGE](#) on page 1067

Width ← Width settings

For the ranges "Shorter" and "Longer", the width defines the maximum and minimum time limit, respectively.

For the ranges "Within" and "Outside", the width defines the center of a range which is defined by the limits "±Delta".

Remote command:

[TRIGger<m>:PARallel:PATtern:WIDTH\[:WIDTH\]](#) on page 1067

±Delta ← Width settings

Defines a range around the given width value.

The combination "Range" = Within and "±Delta" = 0 triggers on pulses with a pulse width that equals "Width".

The combination "Range" = Outside and "±Delta" = 0 means to trigger on pulse widths ≠ "Width".

Remote command:

[TRIGger<m>:PARallel:PATtern:WIDTh:DELTA](#) on page 1068

15.3.5.8 Serial Pattern

The serial pattern trigger identifies a serial bit string trigger on a single digital channel, or for a logical combination of digital channels. The trigger requires a clocked bus; the bits are read at the specified clock edge. The trigger event occurs at the last clock edge of the serial bit string.

This trigger type allows you to trigger on specific address or data transmissions in serial input and output signals.

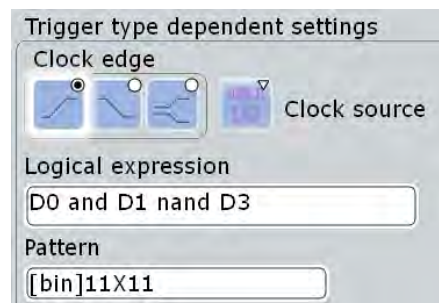

Fig. 15-8: Serial pattern trigger settings for trigger source = logical combination of digital channels

Clock edge

Sets the edge of the clock signal. The bit value is determined at the crossing of the clock edge and the logical threshold.

Remote command:

[TRIGger<m>:PARallel:SPATtern:CSourCe:EDGE](#) on page 1068

Clock source

Selects the digital channel of the clock signal.

Remote command:

[TRIGger<m>:PARallel:DATatoclock:CSourCe\[:VALue\]](#) on page 1059

[TRIGger<m>:PARallel:STATe:CSourCe:VALue](#) on page 1059

[TRIGger<m>:PARallel:SPATtern:CSourCe\[:VALue\]](#) on page 1059

Logical expression

Defines a logic combination of several digital channels as trigger condition if "Logic" is set for "Source". The "Qualification Editor" supports the entry of the expression.

Remote command:

[TRIGger<m>:PARallel:TIMEout:EXPRession\[:DEFine\]](#) on page 1060

[TRIGger<m>:PARallel:STATe:EXPRession\[:DEFine\]](#) on page 1060

[TRIGger<m>:PARallel:PATtern:EXPRession\[:DEFine\]](#) on page 1060

[TRIGger<m>:PARallel:SPATtern:EXPRession\[:DEFine\]](#) on page 1060

Pattern

Defines the serial bit string on which to trigger. Touch and hold the "Pattern" field to open the "Bit Pattern Editor" where you can enter the pattern in various formats. The pattern has to be defined exactly, X (don't care) is not supported in binary format.

See also: [chapter 14.1.4, "Bit Pattern Editor"](#), on page 425

Remote command:

`TRIGger<m>:PARallel:SPATtern:PATtern` on page 1068

16 I/Q Software Interface (Option R&S RTO-K11)

The option R&S RTO-K11 "I/Q Software Interface" acquires modulated signals and outputs I/Q data for further analysis using other software, for example, MATLAB.

Rohde & Schwarz provides also specific software for analysis of I/Q data on external computer:

- R&S FS-K96 OFDM Vector Signal Analysis Software
- FS-K10xPC LTE Analysis Software

Except for the I/Q data recording, the option also provides the NFC trigger type, a specific trigger for Near Field Communication analysis.

- [I/Q Mode](#)..... 536
- [IQ Sampling Setup](#)..... 537
- [I/Q Data Output](#)..... 541
- [NFC Trigger](#)..... 543

16.1 I/Q Mode

Access: MODE > "Acquisition" tab

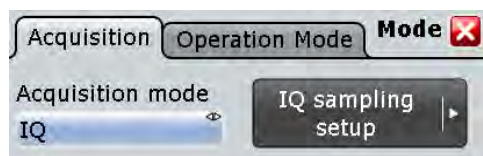

The I/Q mode is a special operating mode of R&S RTO. In this mode, the usual analyzing tools (cursor, zoom, measurements, FFT and so on) of the oscilloscope are deactivated. The instrument displays the magnitude of the I/Q vector to get an impression of the data before it is exported.

Triggering is performed on the input data before conversion to I/Q data, using the usual R&S RTO trigger functionality. In case of complex input signals, the instrument triggers on one component of the complex signal (I or Q) depending on the selected trigger source.

Acquisition mode

Sets the operation mode of the instrument.

- | | |
|----------|---|
| "Normal" | Usual oscilloscope mode |
| "IQ" | I/Q mode to record I/Q data.
The analyzing tools on the toolbar are deactivated, and the magnitude of the I/Q vector is displayed. |

Remote command:

[IQ:STATe](#) on page 1069

16.2 IQ Sampling Setup

In the "IQ Sampling" dialog box you configure the complete I/Q sampling for real and complex input signals.

Access: MODE > "Acquisition" tab > "Acquisition mode" = I/Q > "IQ Sampling Setup"

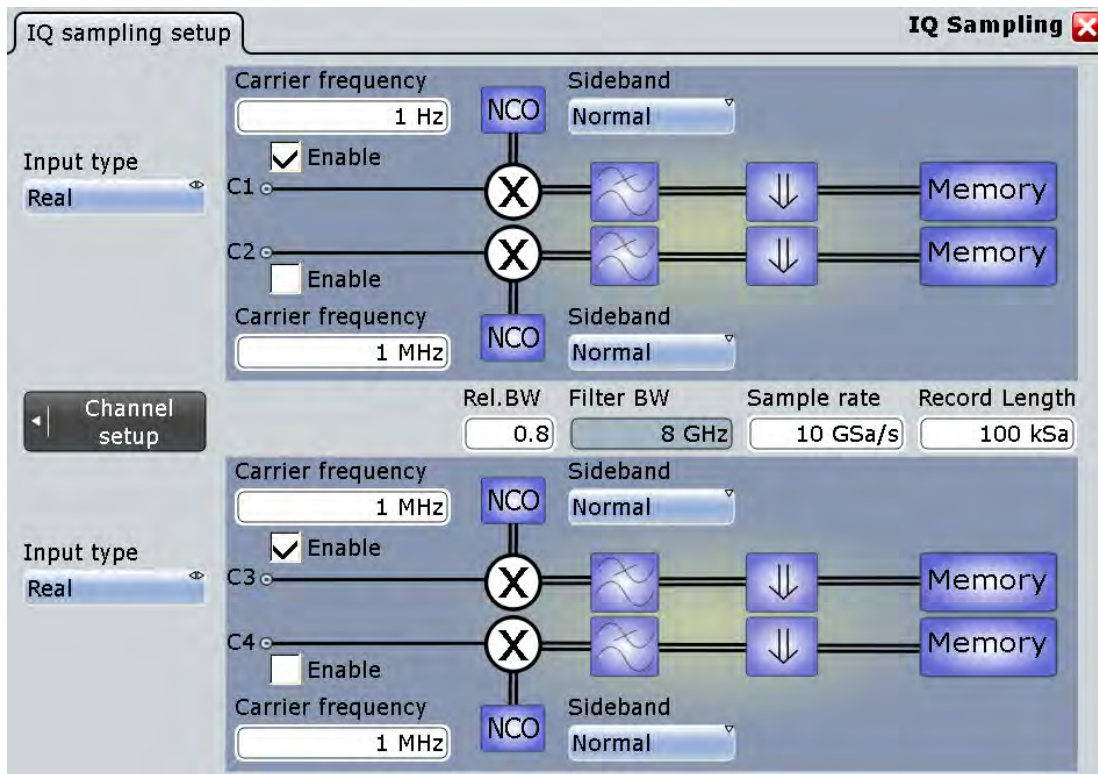

As is usual, the signal icons of the enabled channels show the current settings. In I/Q mode, the I/Q settings are shown:

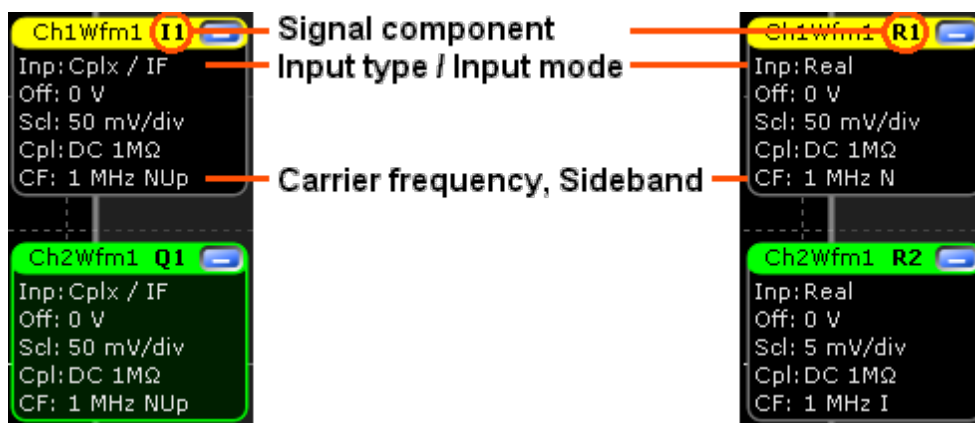

Fig. 16-1: Signal icons. Left side: complex input signal in IF range with carrier frequency 1 MHz and normal/upper sideband. Ch 1 is the in-phase component, ch 2 the quadrature component. Right side: Real input signal with carrier frequency 1 MHz. Ch 1 has normal sideband, Ch2 has inverse sideband.

Input type, Input mode

"Input type" sets the format of the input signal. "Input mode" selects the frequency band of a complex input signal.

The R&S RTO I/Q Software Interface support three formats of input signals.

- Real RF signals

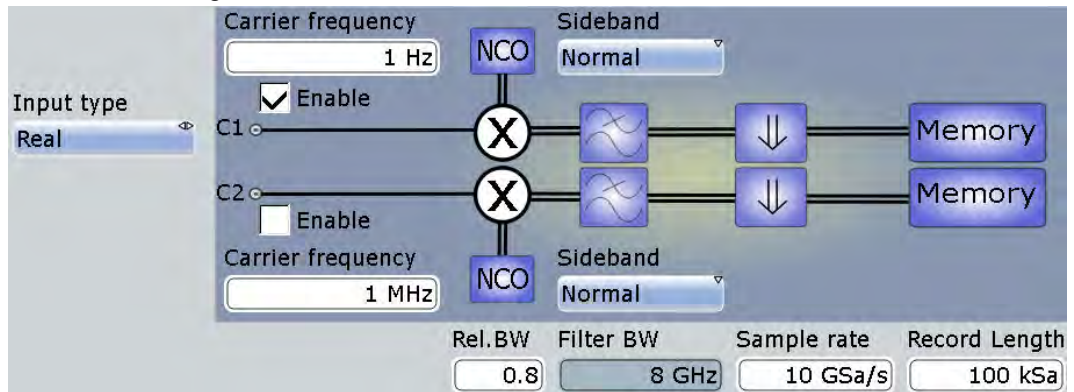

- The input signal is down-converted, filtered and resampled to the sample rate of the output I/Q signal.
- One channel is required for each input signal. Thus up to four real signals can be recorded in parallel.
- Sideband settings: see "[Sideband \(real input\)](#)" on page 540.

- Complex I/Q baseband signals

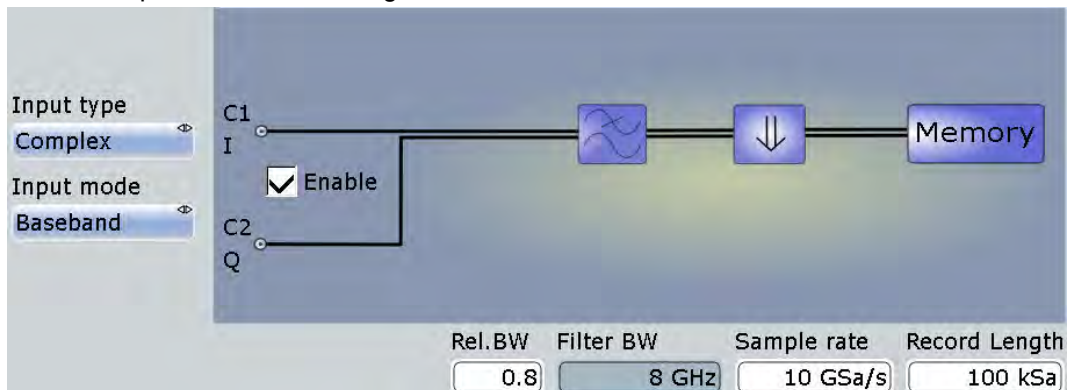

- The input signal is filtered and resampled to the sample rate of the output I/Q signal.
- Two input channels are required for each input signal, one for the in-phase component, and one for the quadrature component. Thus up to two complex input signals can be recorded in parallel.

- Complex I/Q signals in low IF range

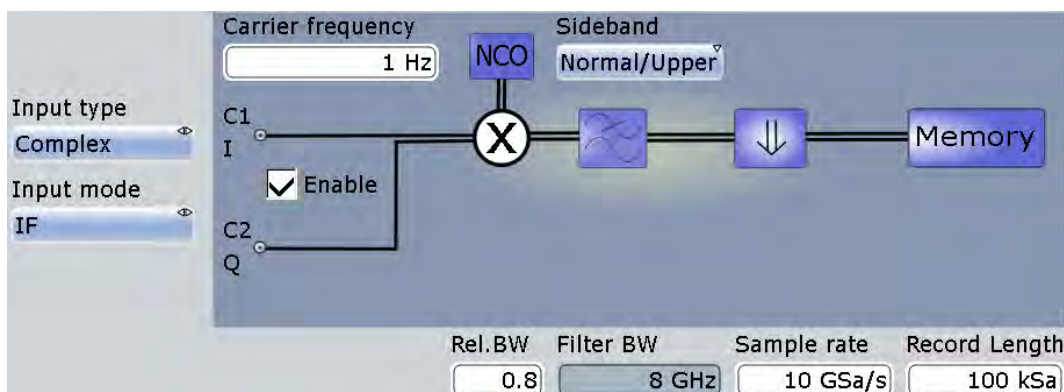

- The input signal is down-converted, filtered and resampled to the sample rate of the output I/Q signal.
- Two input channels are required for each input signal, one for the in-phase component, and one for the quadrature component. Thus up to two complex input signals can be recorded in parallel.
- Sideband settings: see "[Sideband \(complex IF input\)](#)" on page 540.

Remote command:

[CHANnel<m>: IQ: INPType](#) on page 1070

[CHANnel<m>: IQ: INPMode](#) on page 1070

Rel. BW, Filter BW

"Rel. BW" sets the bandwidth factor to define the filter bandwidth:

$$\text{Filter BW} = \text{Relative BW} * \text{Sample rate}$$

Remote command:

[IQ:RBWidth](#) on page 1070

[IQ:BWIDth?](#) on page 1071

Sample rate

Sets the required sample rate of the output I/Q data.

Remote command:

[IQ:SRATe](#) on page 1071

Record length

Sets the required record length of the output I/Q data. The resulting acquisition time of the I/Q data is:

$$\text{Acquisition time} = \text{Record length} / \text{Sample rate}$$

Remote command:

[IQ:RLENgth](#) on page 1071

Show channel

Switches the channel signal on or off. The signal icon appears on the signal bar. The waveform of the last acquisition is displayed in the diagram.

Remote command:

[CHANnel<m>: STATe](#) on page 685

Carrier freq.

Sets the carrier frequency of the modulated RF signal or of the complex signal in IF range.

Remote command:

[CHANnel<m>:IQ:CFrequency](#) on page 1071

Sideband (real input)

Defines the frequency position of the RF spectrum in the input signal: normal or inverse. The position is important for correct down-conversion and filtering.

- "Normal" position of the RF spectrum

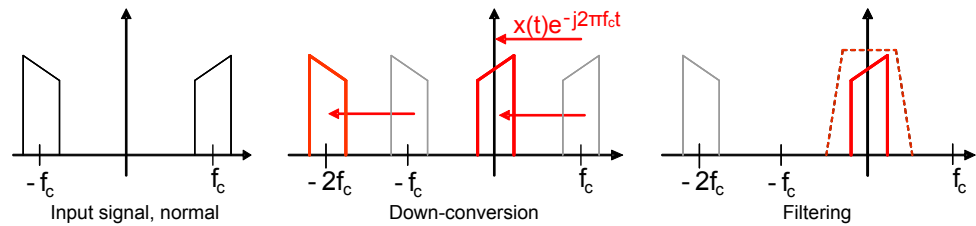

- "Inverse" position of the RF spectrum

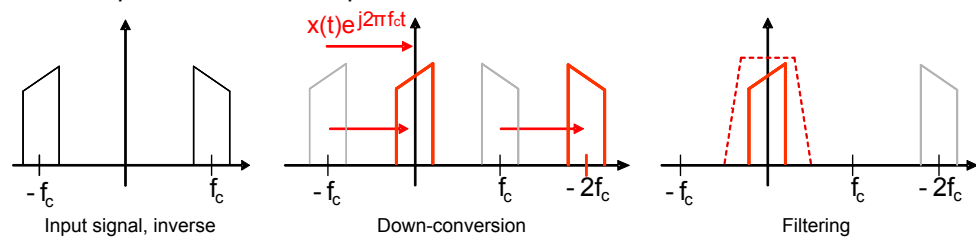

Remote command:

[CHANnel<m>:IQ:SBRF](#) on page 1072

Sideband (complex IF input)

Defines the sideband and the frequency position of complex modulated input signal in IF range.

- "Normal/Upper": Upper sideband in normal position

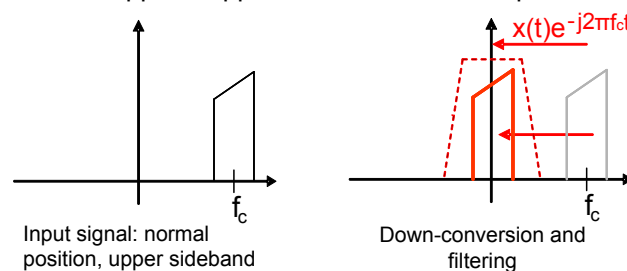

- "Normal/Lower": Lower sideband in normal position

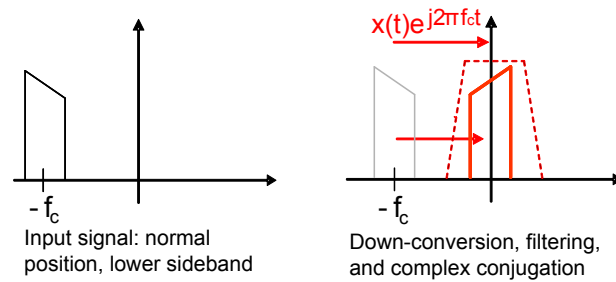

- "Inverse/Upper": Upper sideband in inverse position

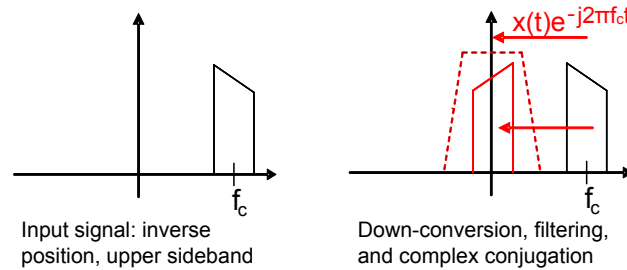

- "Inverse/Lower": Lower sideband in inverse position

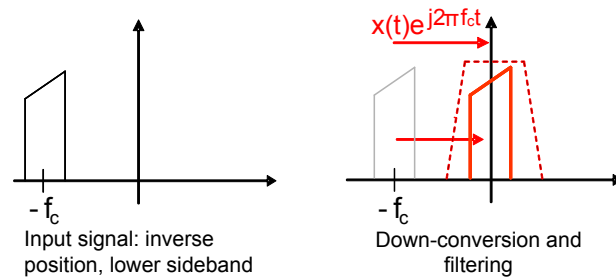

Remote command:

[CHANnel<m>:IQ:SBIF](#) on page 1072

16.3 I/Q Data Output

The recorded I/Q data can be saved manually on hard disc or USB flash device for further analysis, or extracted using remote control from an external computer. If supported by the R&S analysis option, a direct connection and data usage via LAN is also possible.

Access: FILE > "Save/Recall" tab > "Waveforms" tab

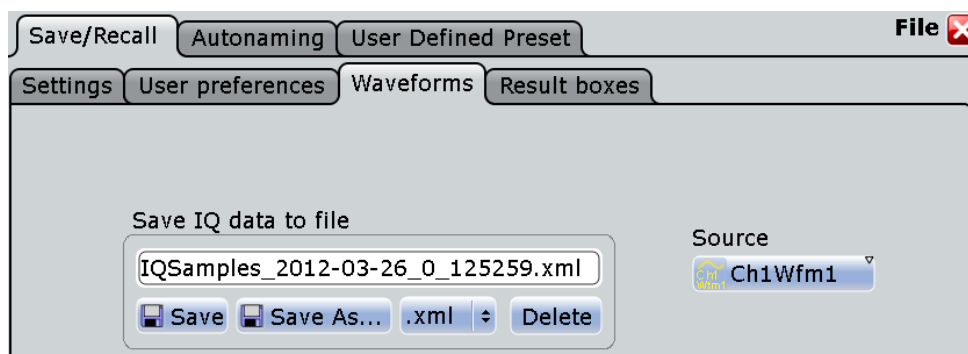

In I/Q mode, the "Waveforms" tab provides all functions to save the recorded I/Q data.

Source

Selects the channel for which the I/Q data is saved. For each input channel, a separate output file is written.

In case of a complex input signal that requires two input channels, the results of sources Ch1Wfm1 and Ch2Wfm1 are identical, as well as the results of Ch3Wfm1 and Ch4Wfm1.

Save IQ data to file

Enter the file name to save the I/Q data to. Double-tap the file name to open the file selection dialog box.

By default, the file name has the prefix "IQSamples_". You can define a pattern for automatic naming in the "Autonaming" tab.

- | | |
|-----------------------------------|---|
| "Save" | Saves the I/Q data in the selected file. |
| "Save As..." | Opens the file selection dialog box and saves the I/Q data to the selected file. See also chapter 11.2.4, "File Selection Dialog" , on page 386 |
| ".iqw/.iq.tar/.bin
/.xml/.csv" | Selects the file format.
iqw: specific format for analysis with R&S I/Q data analysis software. It contains the I and Q values in interleaved order.
iq.tar: iq-tar file format, packed format containing several files: an I/Q parameter XML file, an I/Q data binary file, and an optional I/Q preview XSLT file (stylesheet). A detailed specification of the iq-tar file format is given in http://www.rohde-schwarz.com/en/manual/manual-r-s-iq-tar-file-format-specification-manuals-gb1_78701-37313.html .
csv, xml, and bin: usual formats that are also used for common waveform export, see chapter 11.2.2.1, "Waveform File Formats" , on page 369. |

Remote command:

`CHANnel<m>:IQ:DATA[:VALues]?` on page 1073

`CHANnel<m>:IQ:DATA:HEADer?` on page 1073

16.4 NFC Trigger

The Near Field Communication (NFC) trigger triggers on characteristic events of NFC signals, in particular on polling requests of a device, for example, of a mobile phone.

The trigger source is the NFC signal connected to one of the channel inputs.

You can analyze the triggered signal in two ways:

- In normal instrument mode, you can display and analyze the signal in the time domain.
- In IQ mode, you can acquire and save I/Q data for external analysis on a computer. The R&S RTO display shows the magnitude of the I/Q vector.

Access: TRIGGER > "Setup" tab > "Type" = NFC

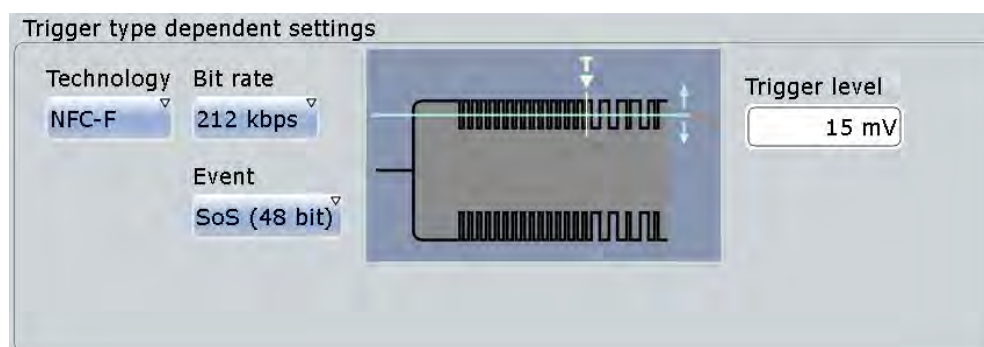

Technology

Selects the NFC technology, the communication protocol used by the input signal.

- | | |
|---------|------------------------------------|
| "NFC-A" | compatible to ISO/IEC 14443A |
| "NFC-B" | compatible to ISO/IEC 14443B |
| "NFC-F" | compatible to JIS X6319-4 (FeliCa) |

Remote command:

[TRIGger<m>:NFC:TECHnology](#) on page 1074

Bit rate

Sets the bit rate of the signal. For NFC-A and NFC-B, the bit rate is always 106 kBit per second. For NFC-F, the bit rate can be either 212 or 424 kBit per second.

Remote command:

[TRIGger<m>:NFC:BITRate](#) on page 1074

Event

Sets the trigger on:

- NFC-A:
ALL_REQ or SENS_REQ command (polling requests)
- NFC-B:
ALLB_REQ or SENSB_REQ command
- NFC-F:

Start of Sequence pattern with 48 bit or 96 bit length

Remote command:

[TRIGger<m>:NFC:EVENT](#) on page 1074

Trigger level

Sets the voltage level for the trigger event. You can also drag the trigger level marker on the display (TA or TB on the right edge of the display). The range of the trigger level is limited in a way so that always a hysteresis for stable trigger conditions is available.

Remote command:

[TRIGger<m>:LEVel<n>\[:VALue\]](#) on page 704

17 Jitter Analysis and Clock Data Recovery (Options R&S RTO-K12/13)

Jitter describes the timing errors in a system. It is a significant and undesired factor in high-speed serial communication designs because it causes transmission errors.

The jitter analysis option R&S RTO-K12 provides common analysis and visualization tools for signal integrity analysis and jitter characterization:

- Automated jitter measurements in time domain
- Track graph of jitter measurement results
- Jitter spectrum
- Eye mask definition and analysis
- Software-based clock data recovery

A wizard guides you through the configuration of most common jitter analysis tasks.

In addition, the option R&S RTO-K13 provides hardware-based clock data recovery. The resulting clock edge stream can be used as trigger source for the CDR trigger.

17.1 Jitter Measurements

The R&S RTO provides two ways to set up jitter measurements:

- The jitter wizard for most common jitter measurements
- The usual measurement setup in the "Jitter" category

Both ways are described in the following chapters.

• Jitter Wizard	545
• Jitter Measurement Types	546
• Jitter Measurement Settings	547
• Jitter Statistics and Histogram	551
• Track of Jitter Measurement Results	552
• Jitter Spectrum	552

17.1.1 Jitter Wizard

The jitter wizard guides you through the configuration of most common jitter analysis tasks:

- Period and frequency
- Cycle-to-cycle jitter
- Time interval error (TIE)
- Skew

After selecting and setting up the measurement type, you can adjust the scaling and the reference level and decide which results you want to see:

- Source signals
- Track of measurement
- Histogram of measurement
- FFT spectrum of track

Other jitter measurement types and more complex setups can be configured using the "Measurement" and "CDR Setup" dialog boxes which are described in the following chapters.

17.1.2 Jitter Measurement Types



The measurement category "Jitter" gathers all measurement types which are useful for jitter analysis. These measurement types are specific jitter measurements as well as the following amplitude/time measurement types.







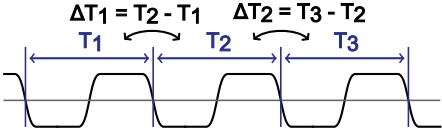

- Period
- Frequency
- Setup time
- Hold time
- Setup/Hold ratio

The amplitude/time measurement types are described in ["Time Measurements"](#) on page 236.

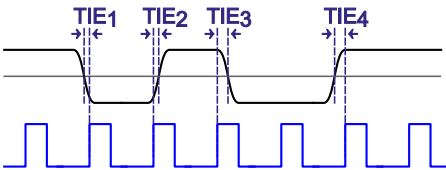
The specific jitter measurement types are described in the following table.

Table 17-1: Jitter measurement types

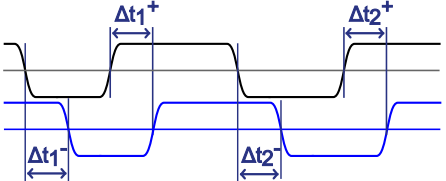
	Measurement type	Description/Result
	Cycle-cycle jitter	<p>Difference between the periods of two adjacent cycles. The measurement is based on the period measurement. You can select the slope from which the period is measured.</p> $\Delta T_{Period\ k} = T_{Period\ k+1} - T_{Period\ k} \quad \text{for } k = 1, \dots, K-1$ 
	N-cycle jitter	<p>Difference between the period of cycles that are N cycles apart. The measurement is based on the period measurement. You can select the slope from which the period is measured.</p> $\Delta T_{Period\ kN} = T_{Period\ k+N} - T_{Period\ k} \quad \text{for } k = 1, \dots, K-N$
	Cycle-cycle width	<p>Difference between the pulse width of two adjacent cycles. The measurement is based on the pulse width measurement. You can select the pulse polarity to be measured.</p> $\Delta T_{Pulse\ k} = T_{Pulse\ k+1} - T_{Pulse\ k} \quad \text{for } k = 1, \dots, K-1$

	Measurement type	Description/Result
	Cycle-cycle duty cycle	<p>Difference between the duty cycle of two adjacent cycles. The measurement is based on the duty cycle measurement. You can select the pulse polarity for the duty cycle measurement.</p> $\Delta R_{Cyc\ k} = R_{Cyc\ k+1} - R_{Cyc\ k} \quad \text{for } k = 1, \dots, K-1$
	Time interval error	<p>Time difference between the slope of the input signal and the slope of a reference signal. The reference signal can be a captured clock waveform, or a clock generated by clock data recovery (CDR, software algorithm or hardware generation). You can select the slope from which the TIE is measured.</p> $TIE_k = t_{Signal\ k} - t_{Clock\ k} \quad \text{for } k = 1, \dots, K$ 
	Unit interval	<p>Period of the clock signal. If no clock signal is available, it is recovered by CDR. The period is calculated as the time difference between two consecutive clock edges of the same polarity.</p> $UI_k = t_{Clock\ k+1} - t_{Clock\ k} \quad \text{for } k = 1, \dots, K-1$
	Data rate	<p>Frequency of the clock signal. If no clock signal is available, it is recovered by CDR. The measurement is based on the unit interval measurement.</p> $R_{Clock\ k} = 1 / UI_k \quad \text{for } k = 1, \dots, K-1$
	Skew delay	<p>Delay between the edges of two interdependent waveforms. The measurement is a simplified variant of the "Delay" measurement assuming that both sources are similar except for the delay.</p> $\Delta t_k = t_{Ak} - t_{Bk} \quad \text{for } k = 1, \dots, K$ 
	Skew phase	<p>Phase difference between the edges of two waveforms.</p> $Skew\ delay / Period * 360^\circ = \Delta t_k / \Delta T_{Period\ k} * 360^\circ$

Limit and margin checks are also available for jitter measurements, see "[Limit check](#)" on page 263. Limit and margin checks are based on the amplitude/time measurements.

17.1.3 Jitter Measurement Settings

Jitter measurements are only available for sources in the time domain.

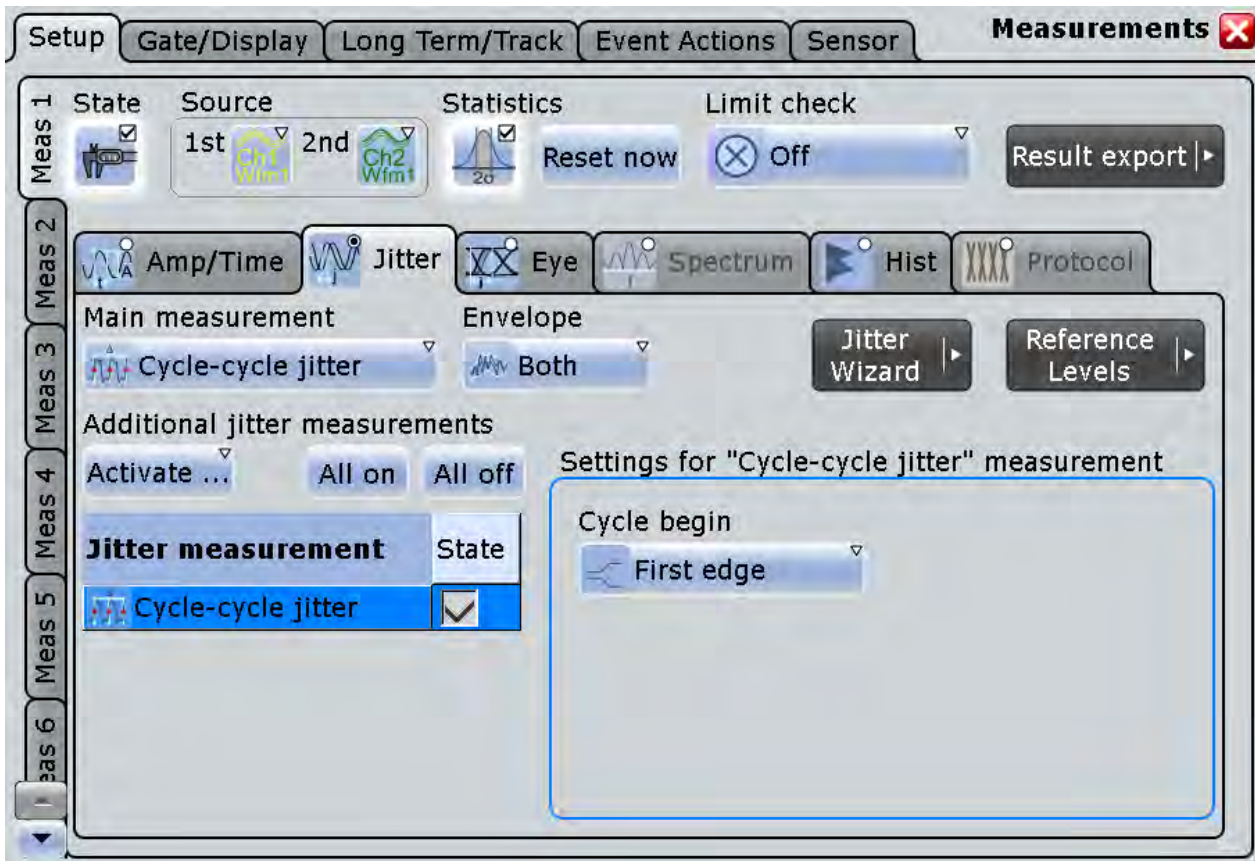

17.1.3.1 Measurement Type Selection

Main Measurement

Defines the main jitter measurement type. This measurement is the one referred to if the measurement result is used as a source for math calculations. The main measurement cannot be disabled.

The default measurement type for jitter measurements is "Period". For details on the available measurement types, see [chapter 17.1.2, "Jitter Measurement Types"](#), on page 546.

Remote command:

`MEASurement<m>:MAIN` on page 792

Additional jitter measurements

In addition to the main measurement type, further jitter measurements can be performed simultaneously. The selected measurement types are displayed in an overview table.

Beside the table, specific settings for the selected measurement type are shown. When you select a measurement type, check and adjust its specific setting(s).

For details on the available measurement types, see [chapter 17.1.2, "Jitter Measurement Types"](#), on page 546.

"Activate" opens the measurement table to select individual measurements

"All on" enables all available additional measurements.

"All off" Deactivates all selected measurements in the table.

Remote command:

[MEASurement<m>:ADDITIONal](#) on page 794

Envelope

See "Envelope" on page 266

17.1.3.2 Clock Measurement Settings

The cycle-cycle measurements are intended to analyze the quality of clock signals. They require a few settings for period and pulse width measurement.

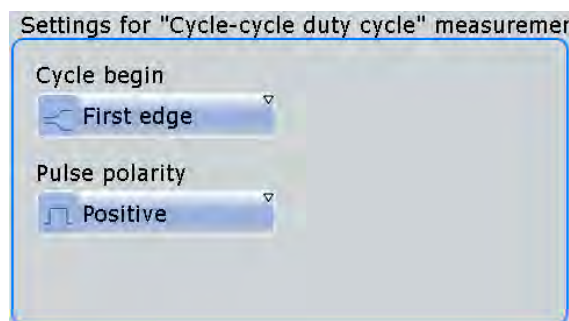

Cycle begin

Selects the slope at which the periods and thus the jitter is measured.

The setting is available for the following measurements: cycle-cycle jitter, N-cycle jitter, and cycle-cycle duty cycle.

"First edge" Measures the period from the first edge that is found, no matter of its direction.

"Positive" Measures the period at positive going edges.

"Negative" Measures the period at negative going edges.

"Either" Measures the period at both positive and negative going edges. This option is useful, for example, to check the clock stability of a double data rate clock.

Remote command:

[MEASurement<m>:JITTer:CCSLope](#) on page 1076

Cycle offset

Sets the distance between the cycles whose periods are taken for the jitter measurement. For example, if "Cycle offset" = $N = 3$, the periods of the first cycle and of the fourth cycle ($N + 1 = 4$) are measured, and their difference is the N-cycle jitter.

The setting is available for the N-cycle jitter measurement.

Remote command:

[MEASurement<m>:JITTer:COFFset](#) on page 1077

Pulse polarity

Sets the polarity of pulses for which the pulse width is measured to obtain the cycle-cycle width and the cycle-cycle duty cycle.

The setting is available for the following measurements: cycle-cycle width and cycle-cycle duty cycle.

"Positive" Pulse width of positive pulses is measured.

"Negative" Pulse width of negative pulses is measured.

Remote command:

[MEASurement<m>:JITTer:PULSe](#) on page 1077

17.1.3.3 Data Measurement Settings

The measurements time interval error, unit interval and data rate are intended to analyze serial data. The clock can be an explicit clock signal, or it can be recovered from the data signal using one of the clock recovery algorithms.

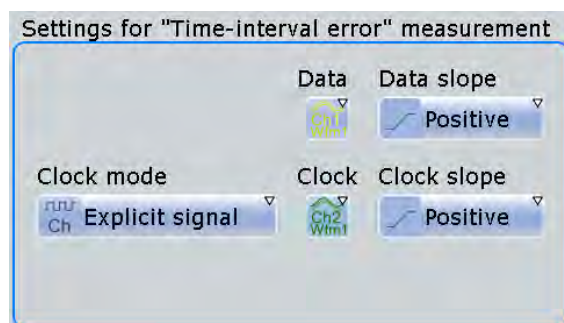
**Clock slope / Data slope**

Set the edges that are used for measurements.

"Data slope" is only relevant for time interval error measurements with real clock signal.

"Positive" The positive clock slope can be used, for example, for single data rate (SDR) signals with bit start at the positive clock edge.

"Negative" The negative clock slope can be used, for example, for SDR signals with bit start at the negative clock edge.

"Either" For clock edges, this option can be used for double data rate (DDR) signals. For data edges, it is the most common setting.

Remote command:

[MEASurement<m>:JITTer:SOURce<n>:TIESlope](#) on page 1078

Clock mode

Defines the origin of the clock signal - whether an existing clock signal or waveform, or a clock generated using one of the CDR methods.

"Explicit signal" The clock is an existing clock signal.

"Software CDR 1 / 2" The clock is generated by a software algorithm. The R&S RTO provides two setups for software CDR, which can be configured and used independently. To configure the CDR, tap "CDR Setup" in the "Analysis" menu.

Remote command:

[MEASurement<m>:JITTer:CDRMode](#) on page 1078

17.1.3.4 Delay Measurement Settings

The measurements skew delay and skew phase are intended to measure the time difference between the edges of two waveforms. The measurements are simplified variants of the "Delay" and "Phase" measurements assuming that both sources are similar except for the delay.

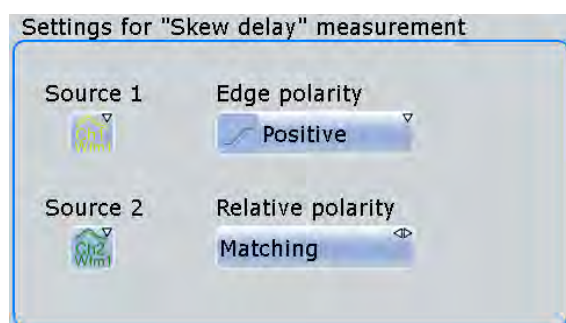

Edge polarity

Sets the edge of the first waveform from which the skew delay or phase is measured: positive, negative or both.

Remote command:

[MEASurement<m>:JITTer:SKWSlope](#) on page 1079

Relative polarity

Sets the edge of the second waveform relative to the first waveform.

"Matching" Measures from positive to positive edge or from negative to negative edge.

"Inverse" Measures from positive to negative edge or from negative to positive edge.

Remote command:

[MEASurement<m>:JITTer:SKWRelation](#) on page 1079

17.1.4 Jitter Statistics and Histogram

Since jitter is a random component of all signals, statistical measurement results are required to characterize the jitter.

To get measurements statistics of a jitter measurement

Prerequisite: the jitter measurement types are selected and configured.

1. Open the "Measurements" dialog box for the jitter measurement by tapping the "Tools" icon in the result box.
2. On the "Setup" tab, enable "Statistics".
3. On the "Gate/Display" tab, enable "Multiple meas".

The histogram plots the density of data. It shows the frequency of occurrence of the measurement values. The maximum count of a measurement value is assigned to the full height of the histogram diagram (= 1000). All other count values are displayed relative to the maximum.

To enable the histogram

1. On the "Long Term/Track" tab, under "Histogram", tap "Enable".
2. If the histogram is not displayed as expected, disable "Continuous auto scale" and adjust the "Meas scale".

17.1.5 Track of Jitter Measurement Results

A track graph displays the results of the main jitter measurement from a single acquisition as a time-correlated waveform. To generate the track graph, multiple measurement points are required. Therefore enabling the track automatically activates the multiple measurement mode.

You can perform amplitude and time measurements on the track waveform. Therefore, configure a new measurement, e.g. "Meas 2", that uses the track waveform as measurement source.

You can also zoom into the track waveform, perform cursor measurements on it, and export the track.

17.1.6 Jitter Spectrum

An extension of jitter measurements is the FFT analysis of track waveforms of jitter measurements. The results are displayed in the frequency domain as a jitter spectrum. The modulation frequency is displayed on the horizontal axis, and the amplitude of modulation on the vertical axis. Using FFT, periodic components can be detected.

17.2 Clock Data Recovery

The process of clock data recovery (CDR) generates a reference clock from a high-speed serial data stream that is sent without a dedicated clock signal. The generated clock signal matches the frequency and is aligned to the phase of the data stream.

There are two ways to recover the clock signal:

- Using software algorithms that calculate the clock from data signal edges
- Using hardware CDR (option R&S RTO-K13)

17.2.1 Software CDR

You can define two independent CDR instances to recover clock signals. These clock signals are used for data timing measurements: time interval error, unit interval, and data rate (frequency of the clock signal).

You can also display the recovered clock signal as a math waveform, see [chapter 17.2.3, "Displaying the Recovered Clock Signal"](#), on page 557.

Access: "Analysis" menu > "CDR Setup" > "SW"

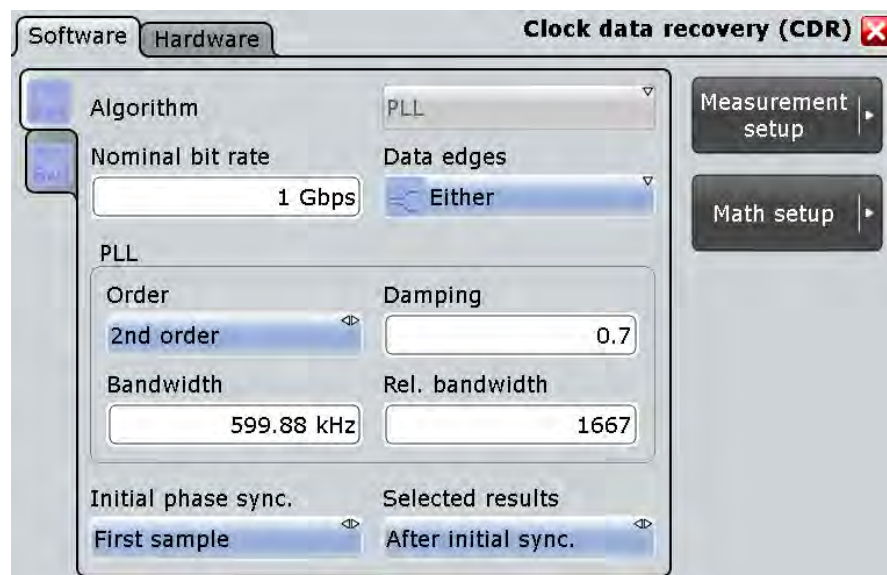

Algorithm

Sets the software algorithm that is used for clock data recovery. Currently, only PLL is supported.

PLL is the phase-locked loop control system. It can follow slow deviations in the frequency of the data stream. Thus, it acts as high-pass filter with respect to the jitter that remains on the signal.

Remote command:

`CDR:SOFTWARE<m>:ALGORITHM` on page 1080

Nominal bit rate

Sets the quiescent frequency of the PLL. It corresponds to the data rate of the data stream from which the clock is to be recovered.

Remote command:

`CDR:SOFTWARE<m>:BITRATE` on page 1080

Data edges

Selects the edges of the data stream that are used for the clock recovery.

- "Either": Both positive and negative edges are used
- "Positive / Negative": Only one edge direction is used. Use one of these settings if the other edge might deliver unreliable results.

Remote command:

[CDR:SOFTware<m>:ESLope](#) on page 1081

PLL settings

Phase-locked loop parameters are listed below.

Note: Nomial bit rate, bandwidth and relative bandwidth are interacting settings. Modifying one parameter also changes one of the dependent parameters.

"Order"	Sets the order of the PLL: first or second order. PLL of higher order can compensate for more complex jitter behavior.
"Bandwidth"	Sets the PLL bandwidth. It defines the part of the spectrum that the PLL can follow during synchronization. The PLL bandwidth is usually defined by the transmission standard.
"Rel. bandwidth"	Sets the relative bandwidth, that is the ratio of the nominal bit rate to the PLL bandwidth.
"Damping"	Sets the damping factor, which is only relevant for second order PLL.

Remote command:

[CDR:SOFTware<m>:PLL:ORDer](#) on page 1082

[CDR:SOFTware<m>:PLL:BWIDth](#) on page 1082

[CDR:SOFTware<m>:PLL:RELBwidth](#) on page 1082

[CDR:SOFTware<m>:PLL:DAMPing](#) on page 1083

Initial phase sync.

Defines the phase reference for the first clock edge.

"First sample"	The first clock edge matches the first sample of the waveform at the left border of the display.
"First data edge"	The first clock edge matches the first edge of the data signal.

Remote command:

[CDR:SOFTware<m>:SYNC](#) on page 1081

Selected results

The PLL requires some time to synchronize to the phase of the data stream. You can select when the CDR algorithm returns clock edges:

"After initial sync."	The clock edges of the synchronization time are discarded; results are gathered after initial synchronization of the CDR. . Thus, meaningful TIE measurement results can be obtained.
"All"	All clock edges are used.

Remote command:

[CDR:SOFTware<m>:RESults](#) on page 1081

17.2.2 Hardware CDR (Option R&S RTO-K13)

Hardware-based clock data recovery uses the digital CDR module to recover the clock edges. These clock edges can be used as trigger source for the CDR trigger.

17.2.2.1 Hardware CDR Setup

Access: "Analysis" menu > "CDR Setup" > "HW"

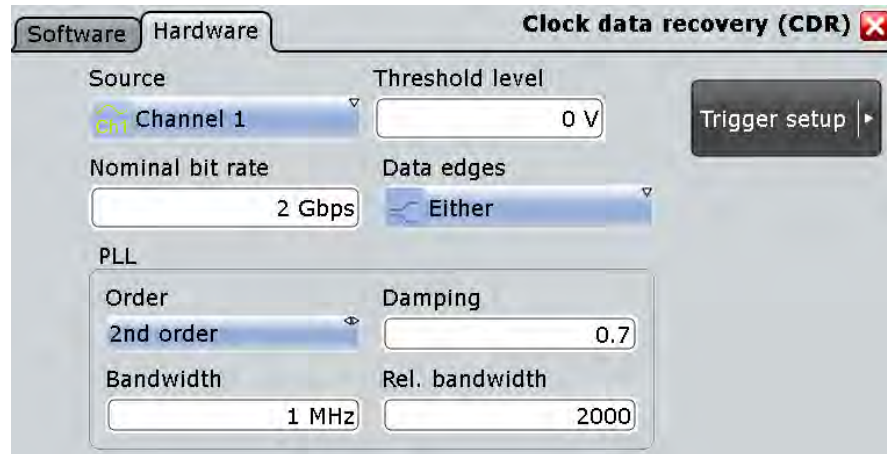

Source

Selects the channel signal that is used for clock recovery.

The source cannot be changed if the CDR trigger is selected in the trigger setup. In this case, the instrument triggers on the recovered clock; trigger source and CDR source are the same.

Remote command:

[CDR:HARDware:SOURce](#) on page 1083

Threshold level

Sets the threshold to determine the position of rising and falling edges in the data input signal. The threshold level is also the trigger level for the specified input channel.

Remote command:

[TRIGger<m>:LEVel<n>\[:VALue\]](#) on page 704

Nominal bit rate

Sets the quiescent frequency of the PLL. It corresponds to the data rate of the data stream from which the clock is to be recovered.

Remote command:

[CDR:HARDware:BITRate](#) on page 1083

Data edges

Selects the edges of the data stream that are used for the clock recovery.

- "Either": Both positive and negative edges are used

- "Positive / Negative": Only one edge direction is used. Use one of these settings if the other edge might deliver unreliable results.

Remote command:

[CDR:HARDware:ESLope](#) on page 1084

PLL settings

Phase-locked loop parameters are listed below.

Note: Nomial bit rate, bandwidth and relative bandwidth are interacting settings. Modifying one parameter also changes one of the dependent parameters.

- "Order" Sets the order of the PLL: first or second order. PLL of higher order can compensate for more complex jitter behavior.
- "Bandwidth" Sets the PLL bandwidth. It defines the part of the spectrum that the PLL can follow during synchronization. The PLL bandwidth is usually defined by the transmission standard.
- "Rel. band-width" Sets the relative bandwidth, that is the ratio of the nominal bit rate to the PLL bandwidth.
- "Damping" Sets the damping factor, which is only relevant for second order PLL.

Remote command:

[CDR:HARDware:PLL:ORDer](#) on page 1084

[CDR:HARDware:PLL:BWIDth](#) on page 1084

[CDR:HARDware:PLL:RELBwidth](#) on page 1084

[CDR:HARDware:PLL:DAMPing](#) on page 1085

17.2.2.2 CDR Trigger

The CDR trigger triggers on the edges of the clock edge stream that is recovered from a data signal using the hardware CDR. The trigger point corresponds to the clock edge that indicates the bit start.

Access: directly from the hardware CDR setup, or TRIGGER > "Events" tab > "Type" = CDR

The screenshot displays the 'Hardware CDR Setup' interface. It is divided into two main sections: 'Trigger type dependent settings' and 'CDR settings'.

Trigger type dependent settings:

- Source:** Shows a signal waveform with a trigger point marked by a vertical dashed line.
- Recovered clock:** Shows a square wave derived from the source signal, with a trigger point marked by a vertical dashed line.
- UI offset:** A numeric input field set to 0.2.
- Trigger level:** A numeric input field set to -632 μV .
- Find level:** A button with a green arrow icon.

CDR settings:

- Nom. bit rate: 2 Gbps
- PLL order: 2nd order
- PLL BW: 1 MHz
- Bit rate/BW: 2000
- Data edges: Either

A 'Hardware CDR Setup' button with a right-pointing arrow is located at the bottom right of the interface.

UI offset

Defines an offset for the clock edge in relation to the bit start, the beginning of the unit interval. The UI offset is a number between 0 and 1. Value 0 matches sets the clock edge to the beginning of the bit period; value 0.5 sets the clock edge to the middle of the bit period.

Remote command:

[CDR:HARDware:UIOffset](#) on page 1086

Trigger level

Sets the voltage level for the trigger event. For CDR, the trigger level is also the threshold level for the specified input channel.

Remote command:

[TRIGger<m>:LEVel<n>\[:VALue\]](#) on page 704

17.2.3 Displaying the Recovered Clock Signal

The clock signal that is recovered by software CDR can be displayed as a math waveform.

1. Press the MATH key.
2. On the "Setup" tab, select the "Advanced" subtab.
3. Double-tap the entry field to open the formula editor.
4. Tap "More".
5. Tap "CDR" and select the software algorithm: SW1 or SW2.
6. Tap the "Ch" icon and select the channel of the data signal.
7. Tap the ")" icon to complete the expression.
8. Tap "Enter".
9. Enable the math signal.

17.3 Mask Testing on Eye Diagrams

Mask testing on eye diagrams allows you to test data signals against eye shapes that are required in the standards. You can select the shape of the eye, enter its dimensions and position the eye on the display. The fail criteria is defined as usual for R&S RTO mask tests, see ["Fail condition, Violation tolerance"](#) on page 327.

The eye mask definition cannot be saved as a mask test. You can save the settings as user defined preset and recall them by loading the preset file. See: [chapter 11.2.1.3, "User-defined Preset"](#), on page 368.

Example:

Eye pattern on a 2.5 Gb/s differential signal using PLL. The eye is open with a PRBS31 pattern.

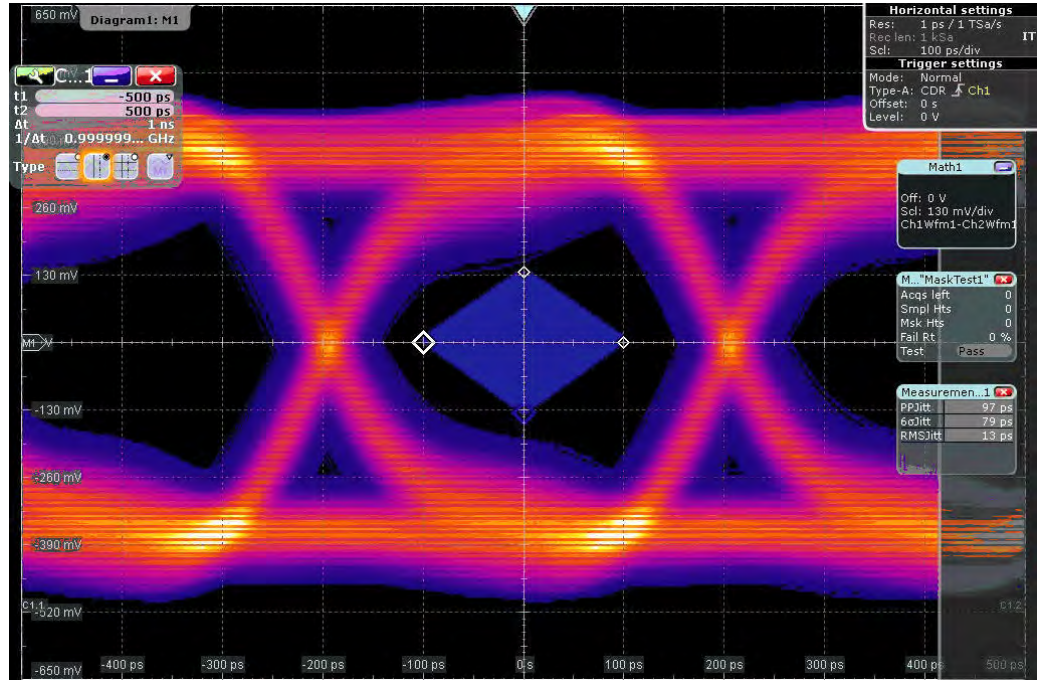

The mask test is set to stop on violation. When an error occurred, the history mode is used to show the cause of the failure. In this case, a single bit transition after a long run caused the error (12 ones followed by a single zero).

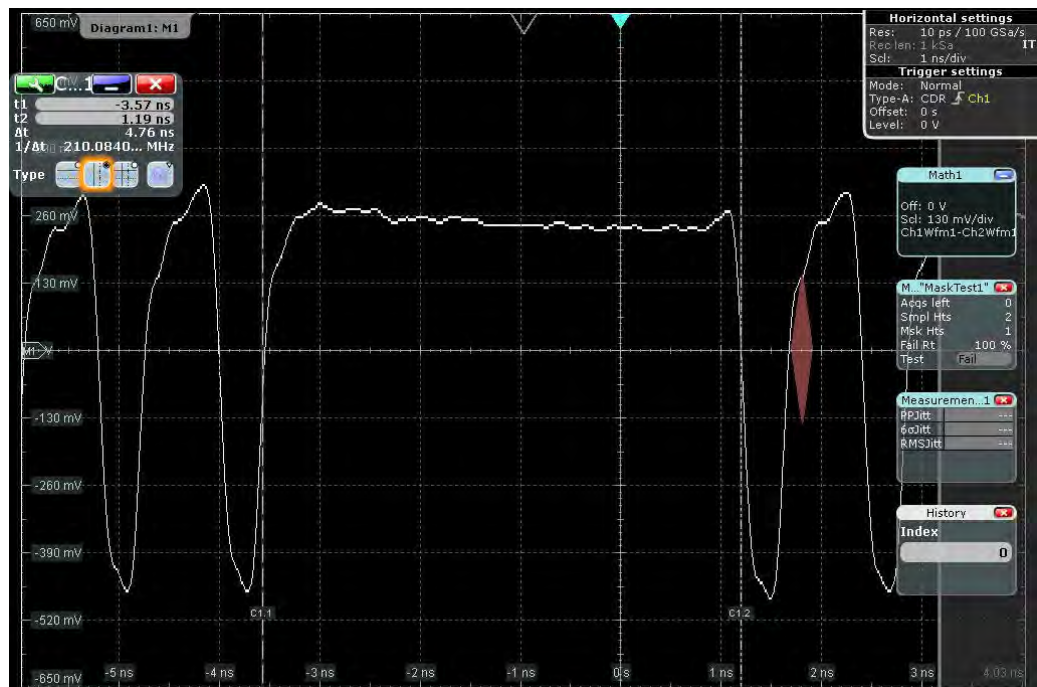

17.3.1 Mask Definition

The jitter option R&S RTO-K12 provides a further definition type to define a mask: "Definition type" = "Eye". The mask definition tab provides all settings that are needed to define the mask according to the relevant protocol standard.

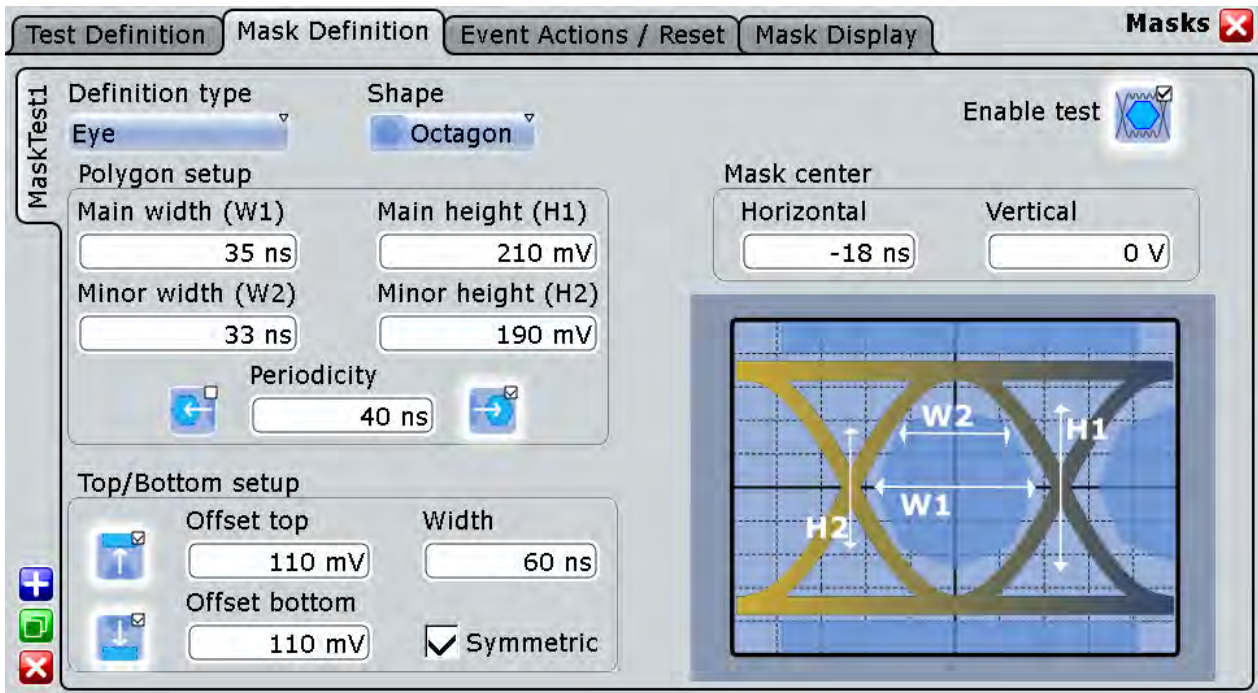

Shape

Defines the outline of the eye mask: square, diamond, hexagon or octagon.

Remote command:

[MTESt: EYEMask: TYPE](#) on page 1087

Main width (W1), Minor width (W2)

Main width defines the width of all eye mask shapes. Minor width defines the secondary width for hexagon and octagon mask shapes.

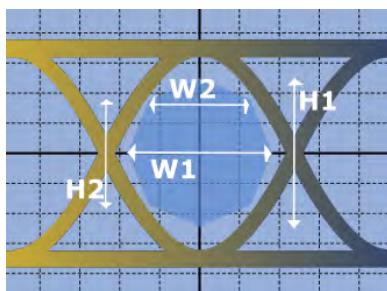

Fig. 17-1: Main and minore widths and heights of an octagon eye mask

Remote command:

[MTESt: EYEMask: WIDTH<m> \[:VALue \]](#) on page 1087

Main height (H1), Minor height (H2)

Main height defines the height of all eye mask shapes. Minor height defines the secondary height for octagon mask shapes.

Remote command:

`MTESt:EYEMask:HEIGht<m>[:VALue]` on page 1087

Periodicity

The icons copy the eye shape to the left and to the right. The value defines the time distance between the shape centers.

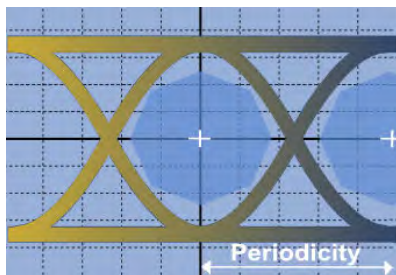

Fig. 17-2: Eye mask with right periodicity

Remote command:

`MTESt:EYEMask:MSKLeft` on page 1088

`MTESt:EYEMask:MSKRight` on page 1088

`MTESt:EYEMask:HPERiod` on page 1088

Top/Bottom setup

The icons enable the upper and/or lower regions of the mask. Use the following settings to configure these regions:

"Offset top, Offset bottom" Voltage distance from the eye shape center that limit the upper and lower regions.

"Symmetric" Sets bottom and top offsets to the same value so that the outer regions are symmetric to the eye shape.

"Width" Time width of the outer regions, symmetric to the eye shape center.

Remote command:

`MTESt:EYEMask:MSKBottom` on page 1088

`MTESt:EYEMask:MSKTop` on page 1088

`MTESt:EYEMask:BOFFset` on page 1089

`MTESt:EYEMask:TOFFset` on page 1089

`MTESt:EYEMask:TBSYmmetric` on page 1089

`MTESt:EYEMask:TBWidth` on page 1089

Mask center: Horizontal, Vertical

Set the horizontal (time) and vertical (voltage) values of the eye shape enter and thus define the position of the eye shape on the display.

Remote command:

`MTESt:EYEMask:HPOSition` on page 1089

`MTESt:EYEMask:VPOSition` on page 1090

Enable test

Starts the mask testing.

18 Power Analysis (Option R&S RTO-K31)

With the R&S RTO and option R&S RTO-K31 you can perform power analysis measurements.

The following power measurements are available:

- Power Quality
- Inrush Current
- Current Harmonic
- Modulation Analysis
- Dynamic ON Resistance
- Slew Rate
- Safe Operating Area (S.O.A.)
- Turn On/Off
- Switching Loss
- Power Efficiency
- Ripple
- Transient Response
- Spectrum

18.1 Power Measurement Selection

Access: "Analysis"> "Power"

The "Power Menu" is the entry point to all power measurements and the general setting required for them.

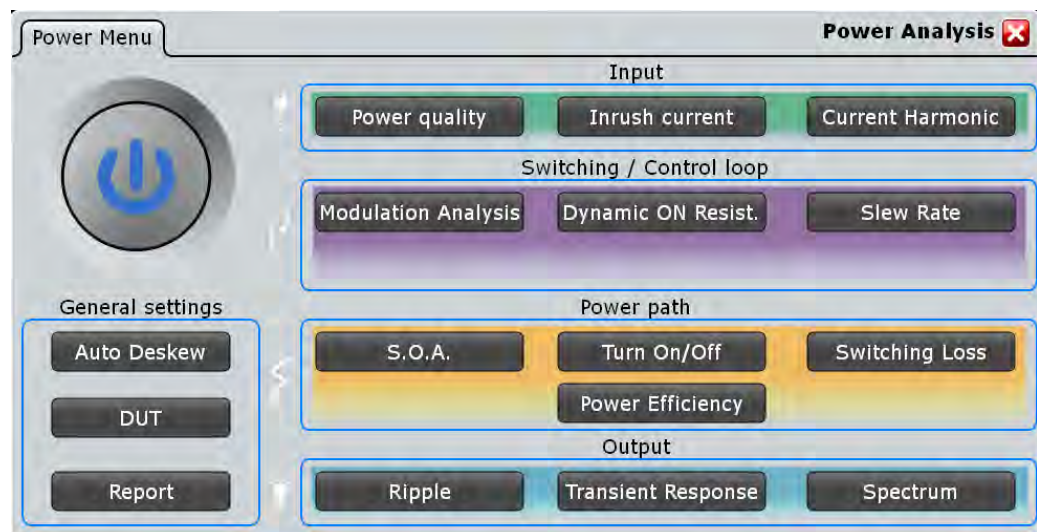

The tab has several areas:

- "General Settings": general settings, that can be used by all measurements, like deskewing.
- "Input": measurements for performing input line analysis. They are used to measure the characteristics of the input power as well as the effects the power supply exudes to the input line.
- "Switching and Control Loop": measurements for characterizing the switching properties of a device.
- "Power Path": measurements for analysing the behavior of the devices that control the power flow through the SMPS circuit, including switching devices and inductors.
- "Output": measurements for characterizing the behavior and quality of the SMPS output voltage.

18.1.1 General Settings

18.1.1.1 Auto Deskew

The "Auto Deskew" dialog box guides you through the auto deskew of your current and voltage probes.

Required equipment:

- R&S RT-ZF20 power deskew fixture
- Rohde & Schwarz voltage probe
- Rohde & Schwarz current probe

1. Select "Analysis" > "Power".
2. Under "General", select "Auto Deskew".
3. Connect the voltage probe and the current probe to the oscilloscope.
4. Connect the probes to the R&S RT-ZF20 power deskew fixture as shown in the "Channels" tab:

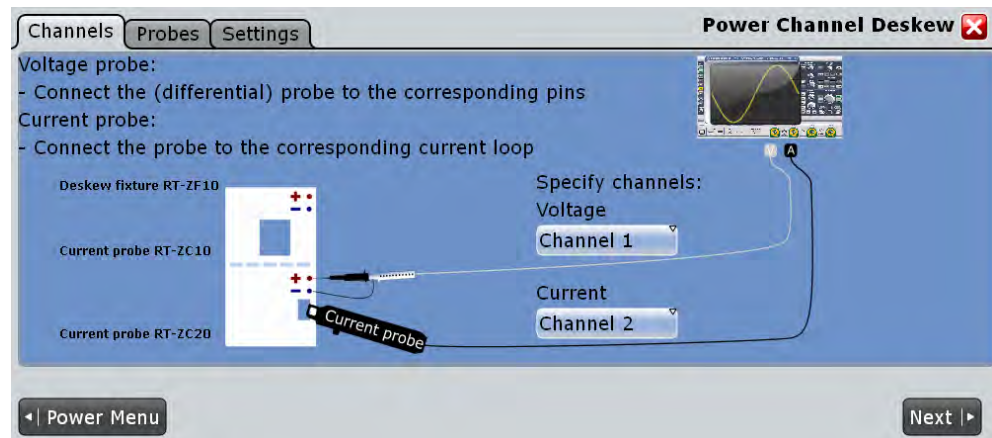

5. Select the correct channels for the "Current Source" and the "Voltage Source".
6. Tap "Next".
7. Check and complete the probe setup in the "Probes" tab.
Current probes and high-voltage differential probes cannot be automatically detected by the instrument. Tap "Predefined probe" and select the correct probe type.
8. Tap the "Settings" tab.
9. Set the ["Overwrite present skew setup"](#) on page 566 and ["Activate user defined preset"](#) on page 566 options. These settings define whether the instrument uses the deskew result for user-defined preset and general skew settings.
10. Tap "Auto deskew".

The probes are deskewed and the measurement can be started.

If no deskew fixture is available, you have to deskew your probes manually, see [chapter 3.3.3, "Probes"](#), on page 119.

Probes

In the "Probes" tab you check and set up your voltage and current probes.

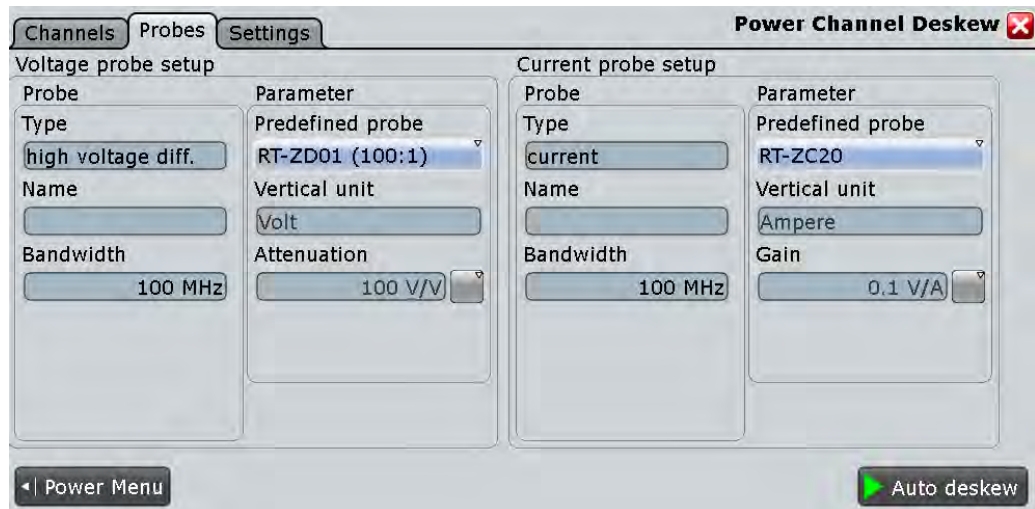

Type, Name, Bandwidth, Probe unit, Auto attenuation

Many probes are recognized by the instrument. The fields show the characteristics of a recognized probe for information. If the instrument cannot recognize the probe, the "Type" is "None".

Remote command:

[PROBe<m>:SETup:TYPE?](#) on page 696

[PROBe<m>:SETup:NAME?](#) on page 696

[PROBe<m>:SETup:BANDwidth?](#) on page 697

[PROBe<m>:SETup:ATTenuation\[:AUTO\]?](#) on page 691

Predefined probe, Vertical unit, Attenuation

Current probes R&S RT-ZCxx, the high voltage active probe R&S RT-ZD01 and the transmission line probe R&S RT-ZZ80 are not recognized automatically but the parameters of these probes are known to the instrument. Select the correct probe type and enter additional parameters if required. The corresponding "Vertical unit" and the "Attenuation" or "Gain" are set.

For an auto deskew, only Rohde & Schwarz probes are supported.

Settings

In this tab you can define the preset behaviour and how the auto deskew results are stored.

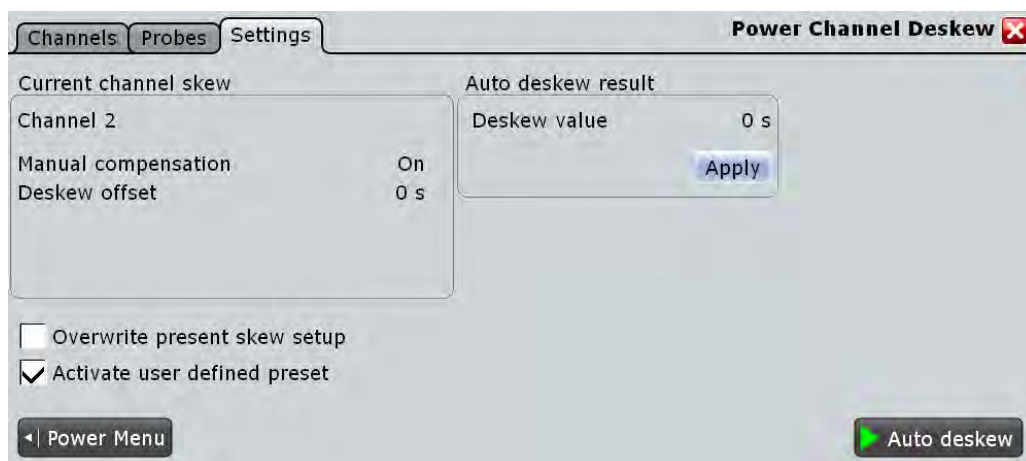

Current channel skew

Shows the skew settings of the channel connected to the current probe. Skew settings are defined in the "Horizontal > Skew" dialog box.

See also: [chapter 3.3.5.2, "Skew"](#), on page 131

Overwrite present skew setup

If disabled, the instrument only stores the result of the auto deskew procedure as a separate value and doesn't use it. This value can be used at a later time for power measurements. The general skew offset under "Current channel skew" remains unchanged.

If enabled, the result of the auto deskew procedure is used for all measurements on the selected channel. It is shown under "Current channel skew".

Remote command:

`POWer:DESKew:RESet` on page 1092

Auto deskew result

Available only if "Overwrite present skew setup" is disabled.

"Deskew value" Result of the auto deskew.

Remote command:

`POWer:DESKew:TIME?` on page 1092

"Apply" Writes the result of the auto deskew to the "Skew offset" of the selected channel.

Remote command:

`POWer:DESKew:CURRent` on page 1091

Activate user defined preset

If enabled, the deskew values are written to a user defined preset file, and the user defined preset is enabled. Thus, the probe setup and deskew values are not influenced by a manual PRESET.

See also: [chapter 11.2.1.3, "User-defined Preset"](#), on page 368.

Remote command:

[POWer:DESKew:UDPReset](#) on page 1092

Auto Deskew

Starts an auto deskew.

Make sure that the probes are configured correctly before you start the deskewing.

Remote command:

[POWer:DESKew:EXECute](#) on page 1091

18.1.1.2 DUT

Access: "Analysis" > "Power" > "DUT".

In this dialog you can describe your device under test (DUT). The information set in this dialog can be used on the title page for a report generated from the "Power Analysis" measurements, see ["Content"](#) on page 571.

The screenshot shows a software dialog box titled "Settings" with a "DUT" label and a close button. The dialog is divided into two main sections. On the left, there are four input fields: "Device under test (DUT)" containing "Demoboard", "User" containing "Rohde&Schwarz", "Site" containing "Munich", and "Temperature" containing "25 °". Each input field has a small icon to its right. On the right side, there is a "Description" text area containing the word "Demo". At the bottom left of the dialog, there is a button labeled "Power Menu".

Device under test (DUT)

Enter a name for your DUT.

Remote command:

[POWer:REPort:DUT](#) on page 1093

User

Enter a user.

Remote command:

[POWer:REPort:USER](#) on page 1093

Site

Enter a site.

Remote command:

[POWer:REPort:SITE](#) on page 1093

Temperature

Enter the temperature.

Remote command:

[POWER:REPort:TEMPerature](#) on page 1093

Description

Enter a description.

Remote command:

[POWER:REPort:DESCRiption](#) on page 1093

18.1.1.3 Report

Access "Analysis">"Power" > "Report".

Test Results

After executing a measurement, you can press "Add to report" and save the results. In this tab you can manage all saved measurement results.

At the top of the tab you can switch through the different "Power Analysis" measurements.

Test results | Layout | Content | **Report** ✖

Inrush Current

DUT	Date	Time	Comment	Add
Demoboard	20/08/2013	14:57:45		<input checked="" type="checkbox"/>
Demoboard	20/08/2013	14:58:11		<input checked="" type="checkbox"/>
Demoboard	20/08/2013	14:58:11		<input checked="" type="checkbox"/>

Select all
Deselect all
Invert selection
Remove selected

Insert Remove Append

Directory
Data\Rohde-Schwarz\RTO\Reports\Demoboard\Inrush Current\20130820-145811

Report_2013-08-20_0_145750.pdf

Power Menu Load Open... Save Save As... .pdf New Delete

Report Table

Shows a list of the available measurements.

After you select a [Directory](#) you can manage previous report results from this directory. To add a measurement report press "Insert" or "Append". To remove a measurement report press "Remove".

"DUT"	Shows the name of the DUT, see chapter 18.1.1.2, "DUT" , on page 567.
"Date"	Shows the date of the measurement.
"Time"	Shows at what time, the measurement result was added to report.
"Comment"	Enters a comment.
"Add"	Adds the selected measurement to the report.

Remote command:

[POWer:REPort:TEST:ADD](#) on page 1094

[POWer:REPort:TEST:COMMeNt](#) on page 1096

[POWer:REPort:TEST:COUNt](#) on page 1097

[POWer:REPort:TEST:INSert](#) on page 1094

[POWer:REPort:TEST:LSENd?](#) on page 1097

[POWer:REPort:TEST:REMOve](#) on page 1094

Selection

Manages the selection of the result reports.

Select all ← Selection

Selects all result reports.

Remote command:

[POWer:REPort:TEST:SEA](#) on page 1095

Deselect all ← Selection

Deselects all result reports.

Remote command:

[POWer:REPort:TEST:DSEA](#) on page 1095

Invert Selection ← Selection

Inverts the selection of all result reports, meaning that all selected result reports are deselected and vice versa.

Remote command:

[POWer:REPort:TEST:ISE](#) on page 1095

Remove selected ← Selection

Removes the selected result report.

Remote command:

[POWer:REPort:TEST:RSE](#) on page 1095

Directory

Selects the directory, from which previous report results are inserted into the report table. You can use this directory to insert previously recorded report data into the current report.

Remote command:

[POWer:REPort:TEST:DIRectory](#) on page 1096

Report Path

Enter the file name to load or to save the report to, and select the file format with the format button on the right.

"Load"	Loads the most recently created report with the Windows default viewer application for the pdf/rtf file format.
"Open"	Opens a file selection dialog box and loads the selected file.
"Save"	Saves the data to the selected file.
"Save As..."	Opens the file selection dialog box and saves the data to the selected file.
".pdf/.rtf"	Selects the file format.
"New"	Creates new file.
"Delete"	Deletes the selected file.

Remote command:

[POWER:REPort:FILE:DELeTe](#) on page 1094

[POWER:REPort:FILE:NAME](#) on page 1094

[POWER:REPort:FILE:NEW](#) on page 1094

[POWER:REPort:FILE:SAVE](#) on page 1094

Layout

In this tab you can set up a layout for your report.

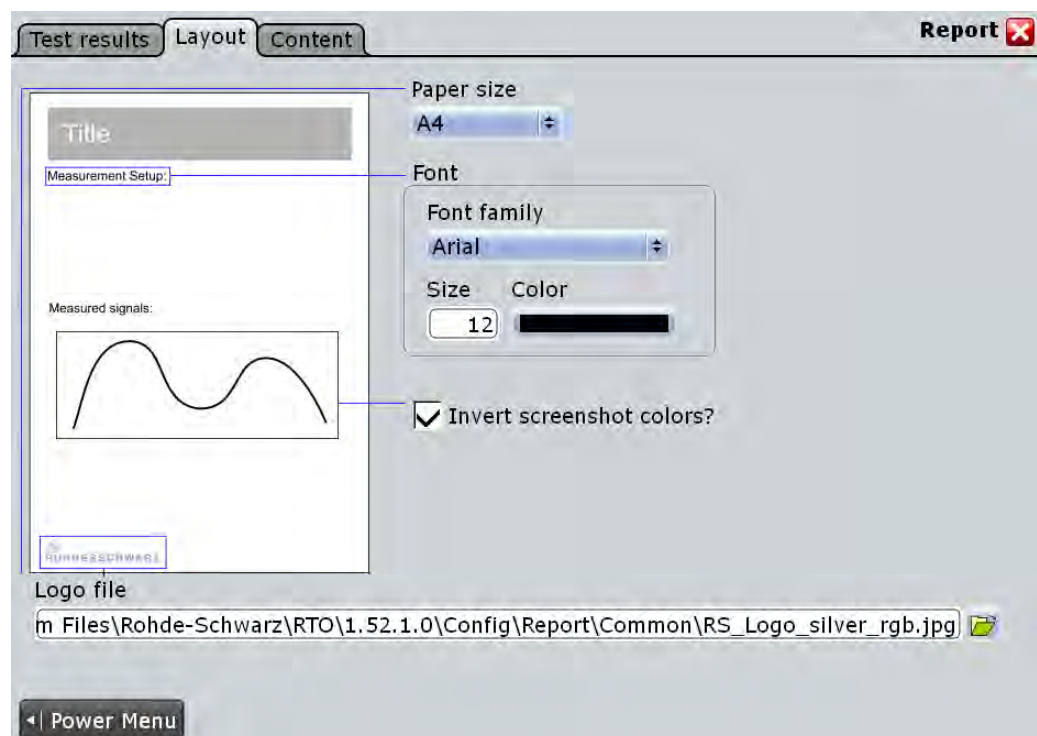

Paper size

Selects the paper size.

"A4" Selects A4.

"US Letter" Selects US Letter.

Remote command:

[POWer:REPort:PAPersize](#) on page 1094

Font

Sets the font for the report

Font Family ← Font

Selects the font family.

"Arial" Selects the font Arial.

"Helvetica" Selects the font Helvetica.

Remote command:

[POWer:REPort:FONT:FAMI](#) on page 1094

Size ← Font

Sets the font size.

Remote command:

[POWer:REPort:FONT:SIZE](#) on page 1094

Color ← Font

Sets the font color.

Remote command:

[POWer:REPort:FONT:COLO](#) on page 1094

Invert Screenshot Colors

Inverts the screenshot colors.

Remote command:

[POWer:REPort:INVert](#) on page 1095

Logo File

Selects a path to a logo picture file.

Remote command:

[POWer:REPort:LOGO](#) on page 1094

Content

In this tab you can select the contents of your report. For each content you can select how often it is included in the report:

- "Always": Shows the respective contents for each measurement.
- "Never": Doesn't show the respective contents in the report.
- "Once": Shows the respective contents once at the beginning of the report.

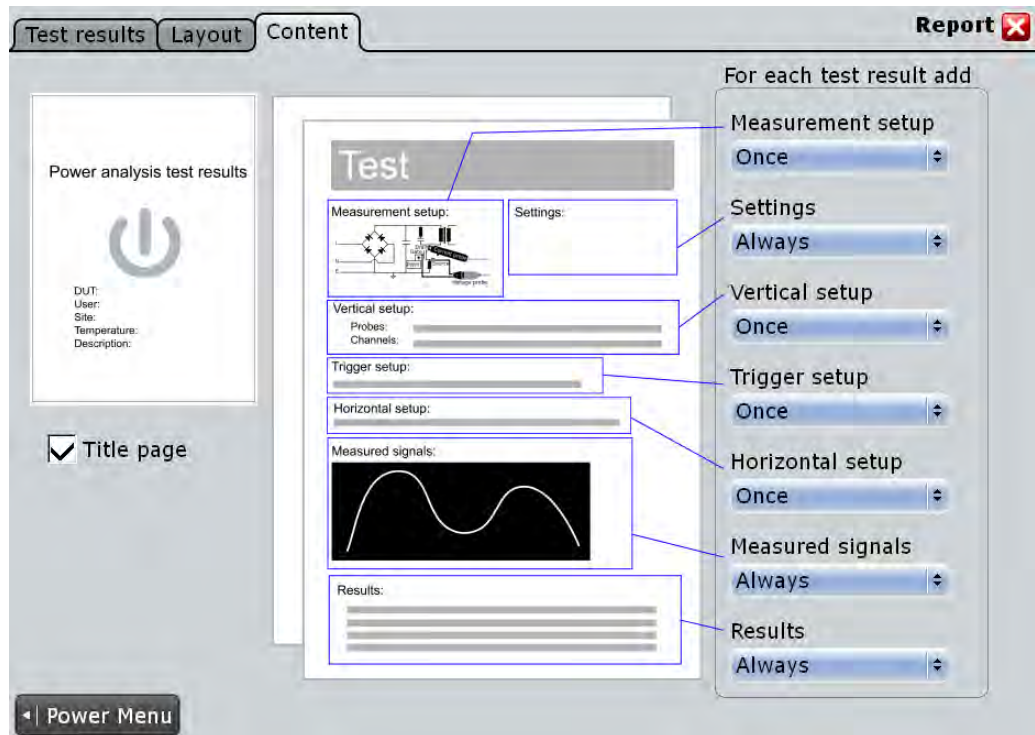

Title Page

Adds a Title page to the report. The contents can be set up in the "DUT" dialog, see [chapter 18.1.1.2, "DUT"](#), on page 567.

Remote command:

`POWer:REPort:CONTent:TITLe` on page 1093

Measurement Setup

Adds a graphic of the measurement setup.

Remote command:

`POWer:REPort:CONTent:MSETup` on page 1093

Settings

Adds the settings of the analysis.

Remote command:

`POWer:REPort:CONTent:SETTings` on page 1093

Vertical Setup

Adds the vertical setup settings.

Remote command:

`POWer:REPort:CONTent:VSETup` on page 1093

Trigger Setup

Adds the trigger setup settings.

Remote command:

`POWer:REPort:CONTent:TSETup` on page 1093

Horizontal Setup

Adds the horizontal setup settings.

Remote command:

[POWER:REPort:CONTent:HSETup](#) on page 1093

Measured signals

Adds a diagram of the measured signal.

Remote command:

[POWER:REPort:CONTent:MSIGnal](#) on page 1093

Results

Adds the result box.

Remote command:

[POWER:REPort:CONTent:RESU](#) on page 1093

18.2 Overview of Power Measurement Setup

Each power analysis measurement dialog box consists of the following tabs:

- Channels
- Settings
- Details

At the bottom of each tab you can find two buttons. Tapping "Power Menu", you can return to the power analysis measurement selection. "Execute" starts the power measurement.

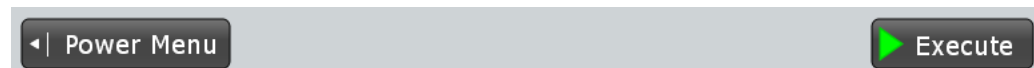

18.2.1 Channels Tab

In the "Channels" tab you find information on the experimental setup of the selected power measurement. A short description explains what probes are needed and how to connect them. The description is supported by a block diagram of the experimental setup that shows the connection points for the probes.

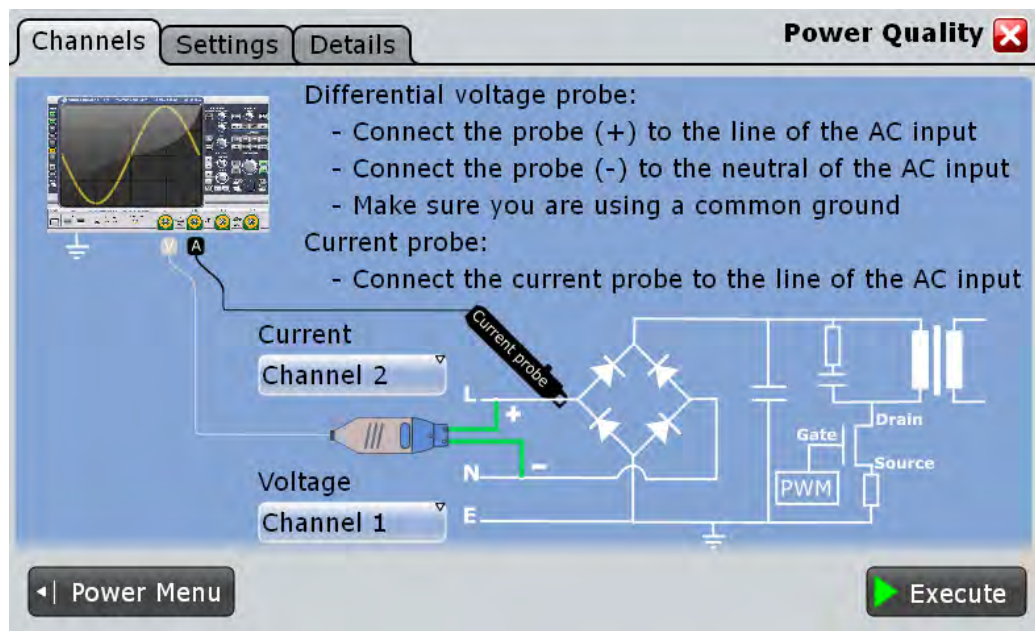

Depending on the selected power measurement, one or two voltage sources and current sources are required.

Current Source

Sets the channel for the current source.

Remote command:

[POWer:SOURce:CURRent<1..2>](#) on page 1091

Voltage Source

Sets the channel for the voltage source input.

Remote command:

[POWer:SOURce:VOLTage<1..4>](#) on page 1091

18.2.2 Settings Tab

In the "Settings" tab you configure the measurement and display settings. The settings depend on the selected power measurement.

For detailed information, see the "Settings" chapter of the relevant power measurement description.

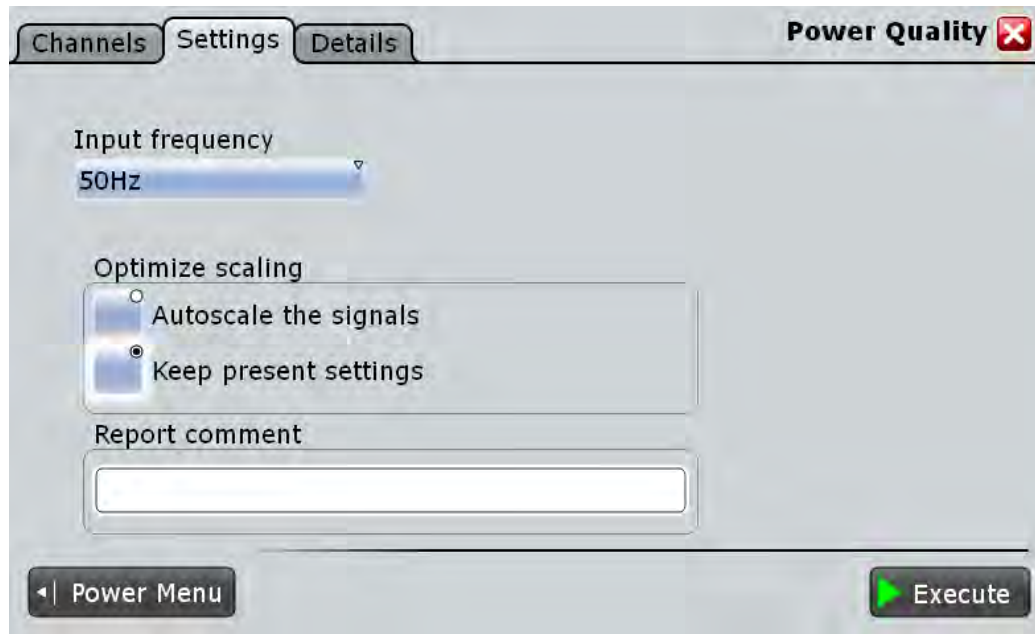

18.2.3 Details Tab

In the "Details" tab you find information on the measurement resources used by the selected power measurement.

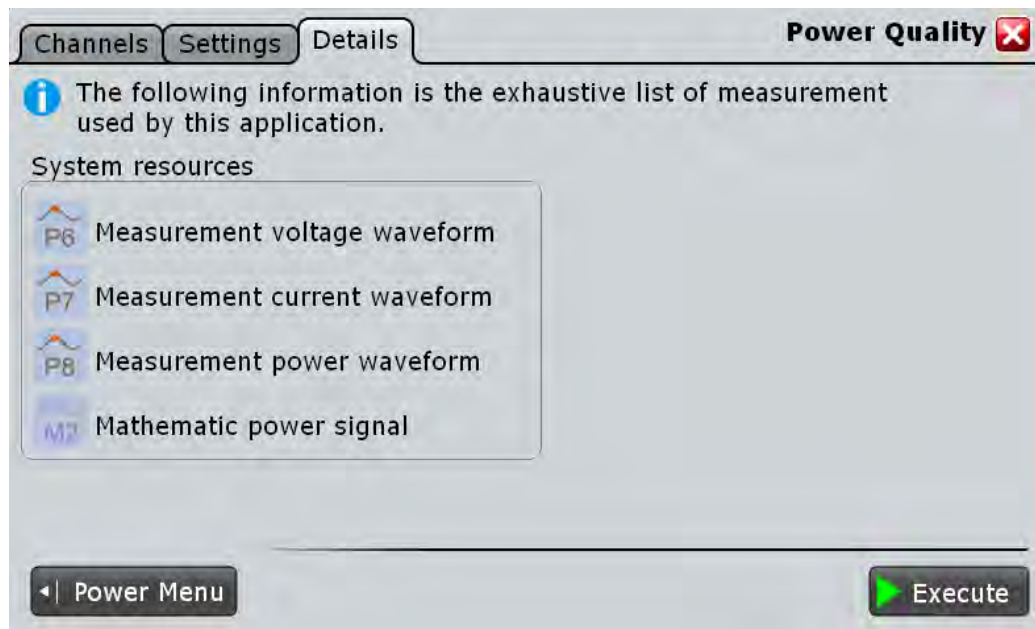

The following resources may be used:

- Measurements
- Mathematic waveforms
- Cursors

- XY-diagrams

The instrument enables the required resources when the power measurement is started.

18.3 Power Quality

In an electric circuit power is a measure for the rate of flow of energy at a certain point of the circuit. The real power of a circuit, or the energy that can be used for work, is the portion of energy that is transferred in one direction over a complete cycle of the AC waveform. In AC circuits, however, inductive and capacitive elements can store energy temporarily. This portion of the power flow known as reactive power is then returned to the source without doing any work.

The "Power Quality" analysis measurements include the real power, the reactive power and the apparent power as well as the power factor. The crest factors and the phase angle between the current and voltage are also measured. These properties describe the power transfer in the system and allow you to characterize the power quality of the system.

Required probes:

- Differential voltage probe
- Current probe

18.3.1 Power Quality Results

The results of "Power Quality" measurements are provided in two ways:

- The diagram shows the graphical presentation of:
 - the voltage waveform
 - the current waveform
 - the power waveform that is the product of the current and voltage waveforms
- The result box displays the numeric measurement results.

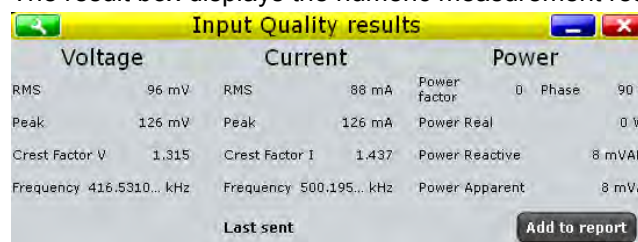

Input Quality results							
Voltage		Current		Power			
RMS	96 mV	RMS	88 mA	Power factor	0	Phase	90 °
Peak	126 mV	Peak	126 mA	Power Real			0 W
Crest Factor V	1.315	Crest Factor I	1.437	Power Reactive			8 mVAR
Frequency	416.5310... kHz	Frequency	500.195... kHz	Power Apparent			8 mVA
Last sent				Add to report			

To measure and display the power quality, the instrument uses the following measurements and waveforms:

- "P6" Meas 6 to measure the voltage
- "P7" Meas 7 to measure the current
- "P8" Meas 8 to measure the power
- "M2" Math 2 to calculate the power

The used resources are listed in the "Details" tab. See also: [chapter 18.2.3, "Details Tab"](#), on page 575.

Voltage and current results

The voltage and current results are defined as follows:

Result	Description
RMS	Square root of the mean of the square of the current or voltage averaged over N cycles
Peak	Highest measured magnitude value of the voltage or current
Crest factor	Peak value / RMS value
Frequency	Frequency of the signal

Power results

The power in a system is described by several physical quantities: real power, reactive power, complex power, and phase angle. In [figure 18-1](#) you can see how these quantities are related if the voltage and the current are sinusoidal signals.

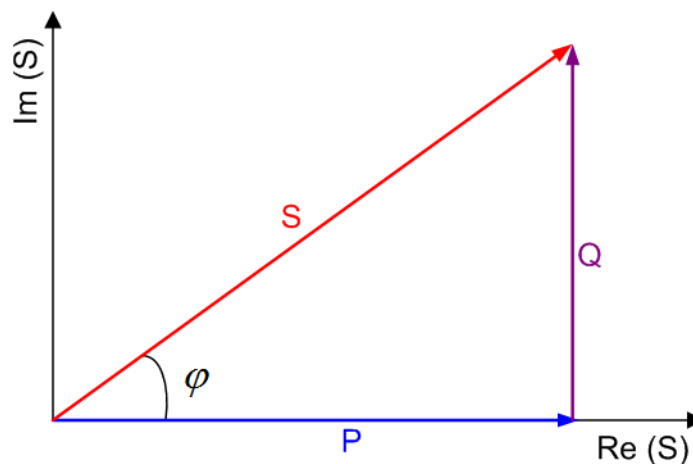

Fig. 18-1: Power diagram for sinusoidal signals

P = real power [W]

Q = reactive power [VAR]

S = complex power [VA]

φ = phase angle between the current and the voltage sine waves [°]

The power results are defined as follows:

Result	Unit	Formula	Description
Power factor, P_{Factor}	-	$P_{Factor} = P / S $	Measure of the system efficiency. The value varies between -1 and 1.
Phase, φ	°	$\varphi = \arccos(P_{Factor})$	Phase angle between the current and the voltage sine waves.

Real power, P	W	$P = V_{INSTANTENEOUS} \cdot I_{INSTANTENEOUS}$ (averaged over N cycles)	Energy of the system that can be used to do work.
Reactive power, Q	VAR (Volt-Ampere reactive)	$Q = S \sin \phi$	Power flow that is temporarily stored in a system because of the inductive and capacitive elements.
Apparent power, S	VA	$ S = V_{RMS} \cdot I_{RMS}$ (averaged over N cycles)	S is the magnitude of the vector sum of real and reactive power (the complex power S).

The following remote commands are used for handling the measurement results:

- [POWER:QUALITY:RESult:CURRent:CREStfactor?](#) on page 1098
- [POWER:QUALITY:RESult:CURRent:FREQuency?](#) on page 1098
- [POWER:QUALITY:RESult:CURRent:PEAK?](#) on page 1098
- [POWER:QUALITY:RESult:CURRent:RMS?](#) on page 1098
- [POWER:QUALITY:RESult:POWer:APParent?](#) on page 1098
- [POWER:QUALITY:RESult:POWer:PFACTOR?](#) on page 1098
- [POWER:QUALITY:RESult:POWer:PHASe?](#) on page 1098
- [POWER:QUALITY:RESult:POWer:REACTive?](#) on page 1098
- [POWER:QUALITY:RESult:POWer:REALpower?](#) on page 1098
- [POWER:QUALITY:RESult:VOLTage:CREStfactor?](#) on page 1098
- [POWER:QUALITY:RESult:VOLTage:FREQuency?](#) on page 1098
- [POWER:QUALITY:RESult:VOLTage:PEAK?](#) on page 1098
- [POWER:QUALITY:RESult:VOLTage:RMS?](#) on page 1098
- [POWER:QUALITY:REPort:ADD](#) on page 1098

18.3.2 Configuring Power Quality

For details of the configuration settings, see [chapter 18.3.3, "Power Quality Settings"](#), on page 579.

1. Select "Analysis" > "Power".
2. Under "Input", select "Power Quality".
3. Connect the differential voltage probe and the current probe to the oscilloscope.
4. Deskew the probes as described in [chapter 18.1.1.1, "Auto Deskew"](#), on page 563.
5. Connect the probes to the DUT as shown in the "Channels" tab:

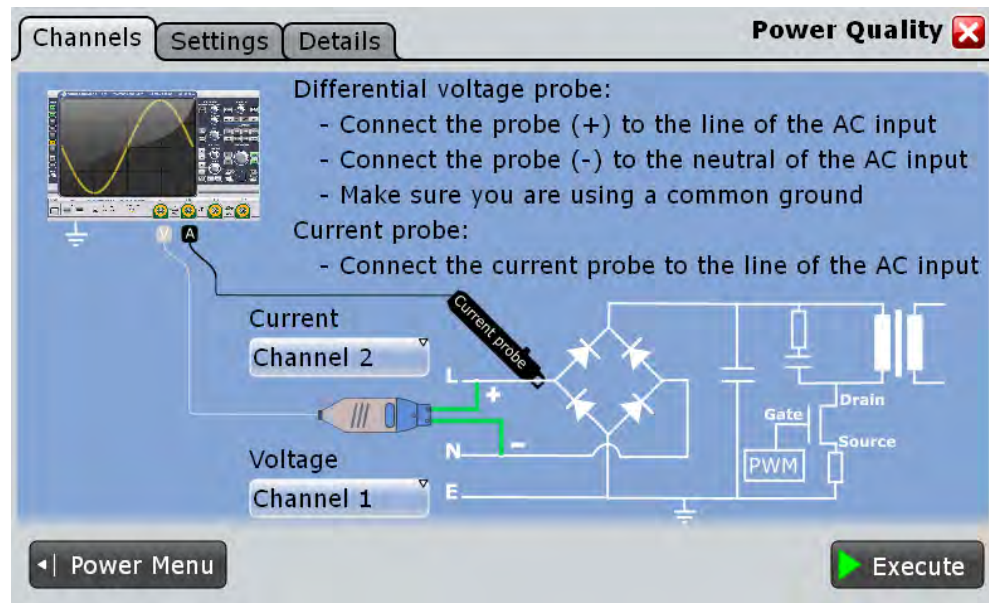

6. Select the correct channels of the "Current Source" and the "Voltage Source".
7. Select the "Settings" tab.
8. Set the "Input frequency" according to your signal.
9. Select an "Optimize Scaling" option.
10. Tap "Execute".

On the screen you can see the measurement waveforms of the current, the voltage and the power. Additionally, the result box with numeric measurement results is shown. For details, see [chapter 18.3.1, "Power Quality Results"](#), on page 576.

18.3.3 Power Quality Settings

In the "Channels" tab, you set the current source and the voltage source, see also: [chapter 18.2.1, "Channels Tab"](#), on page 573.

In the "Settings" tab you configure the power measurement parameters and display settings.

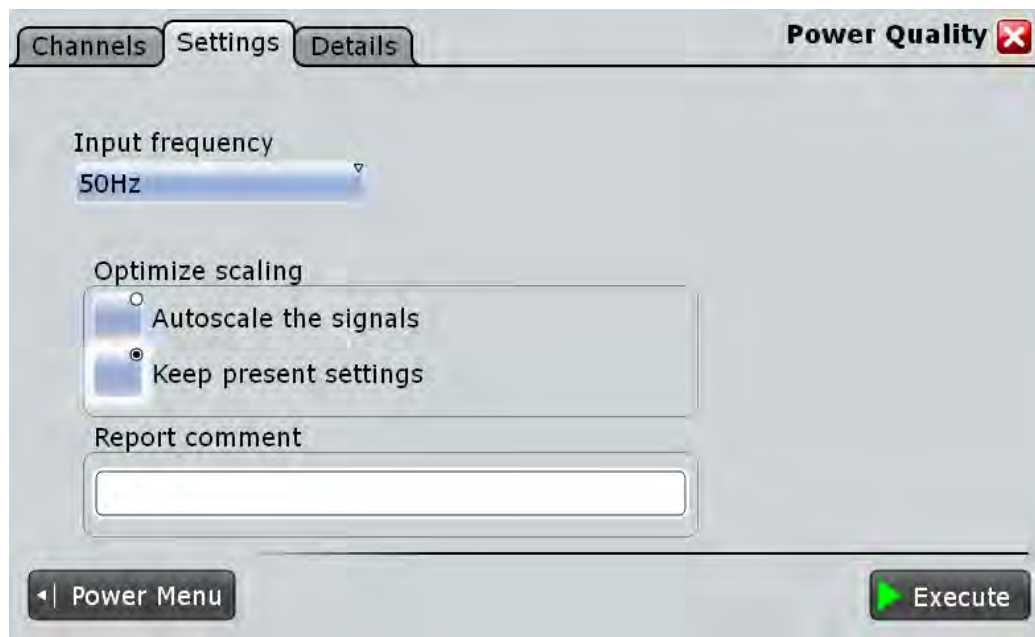
**Input Frequency**

Selects the input frequency of the source signal.

Remote command:

[POWER:QUALity:FREQ](#) on page 1098

Optimize scaling

Selects the scaling for the display of the results.

"Autoscale the signals"

Automatically selects the most appropriate scale for the display of the results.

"Keep present settings"

The present display settings are not changed.

Remote command:

[POWER:QUALity:AUTO](#) on page 1097

Report comment

In this field you can write a comment that will be displayed in the measurement report, for example, a measurement description.

Execute

Starts the "Power Quality" measurement.

Remote command:

[POWER:QUALity:EXECute](#) on page 1098

18.4 Inrush Current

The "Inrush Current" analysis measures the peak of the input current that is drawn by the device, when the device is first turned on.

Required probes:

- Current probe

18.4.1 Inrush Current Results

The results of "Inrush Current" measurements are provided in two ways:

- The diagram shows the graphical presentation of:
 - the current waveform
- The result box displays the following numeric measurement results:
 - "Start time" / "Stop time" define the time period for the present gate
 - The "Value" stands for the maximum amplitude of the current for the present time period. This is the inrush current for the correspondent gate.



Start time	Stop time	Value	
1	0 s	100 µs	158.103 mA

To measure and display the inrush current, the instrument uses the following measurements and waveforms:

- "P1" to "P5": Meas 1 to Meas 5 to measure the inrush current of "Gate 1" to "Gate 5"

The used resources are listed in the "Details" tab. See also: [chapter 18.2.3, "Details Tab"](#), on page 575.

The following remote commands are used for handling the measurement results:

- `POWer:INRush:GATE<m>:VALue` on page 1100
- `POWer:INRush:REPort:ADD` on page 1101

18.4.2 Configuring Inrush Current

For details of the configuration settings, see [chapter 18.4, "Inrush Current"](#), on page 581.

1. Select "Analysis" > "Power".
2. Under "Input", select "Inrush Current".
3. Connect the current probe to the oscilloscope.
4. Select the correct channel for the "Current Source".

5. Select "Vertical" > "Probe Setup" > "Channel" and set your probe parameters.
6. Connect the probes to the DUT as shown in the "Channels" tab:

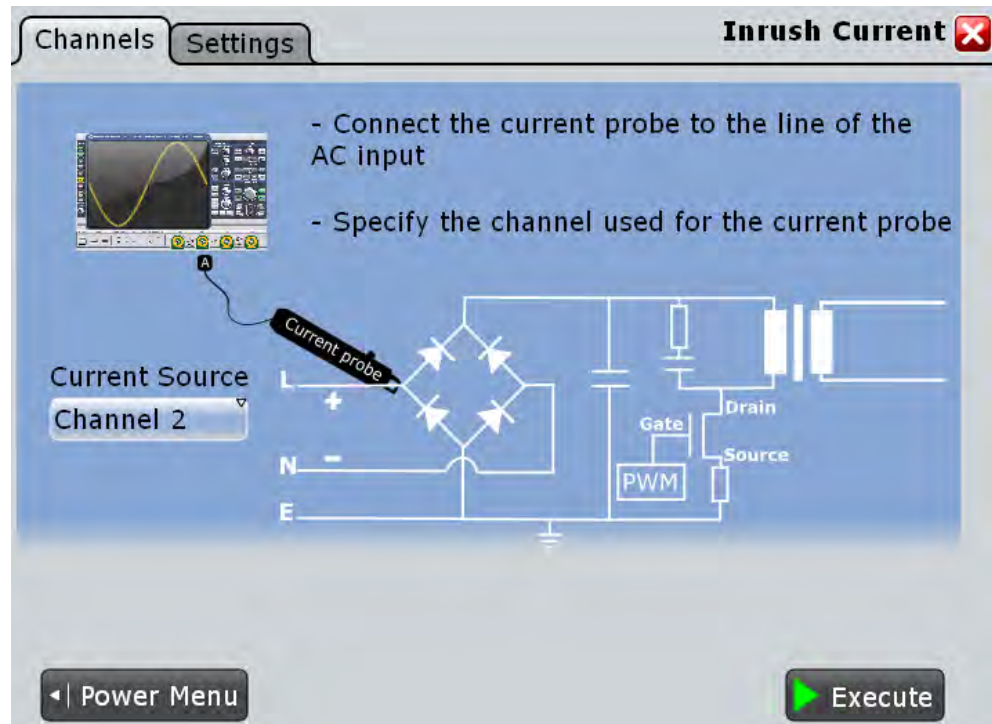

7. Select the "Settings" tab.
8. Set the "Trigger current value".
9. Set the "Maximum current" that shall be displayed in the vertical scale.
10. In the "Gate configuration" table, define the different time periods. You can set up to five different gates.
11. Tap "Execute".
12. Start the DUT.

On the screen you can see the result box with the inrush current of each gate. For details, see [chapter 18.4.1, "Inrush Current Results"](#), on page 581.

18.4.3 Inrush Current Settings

In the "Channels" tab, you set the current source, see also: [chapter 18.2.1, "Channels Tab"](#), on page 573.

In the "Settings" tab you configure the inrush current measurement parameters and display settings.

Channels Settings **Inrush Current** ✖

Configure the gates according to your inrush current specification.

i To avoid saturation, set the vertical scale maximum current

A Maximum current

Gate 1 Gate 2 Gate 3

Inrush Current	Start time	Stop time
1	0 s	100 μs

Trigger (T) current value

Report comment

◀ Power Menu ▶ Execute

Maximum current

Sets the maximum expected current for the vertical scale. Set the value according to your signal in order to avoid saturation.

Remote command:

[POWER:INRush:MAXCurrent](#) on page 1100

Trigger current value (T)

Sets the current value for the trigger. The measurement starts after the signal of the DUT reaches this current value.

Remote command:

[POWER:INRush:TRIGger](#) on page 1100

Gate Configuration

In this table you can configure different gates (time periods). You can configure up to five different gates. The time periods of the defined gates may overlap.

To add a gate press "Insert" or "Append". To remove a gate press "Remove".

Remote command:

[POWER:INRush:ADD](#) on page 1099

[POWER:INRush:INSert](#) on page 1099

[POWER:INRush:REMOve](#) on page 1099

Inrush current ← Gate Configuration

Shows the index of the gate.

Remote command:

`POWer: INRush: COUNT?` on page 1099

Start time ← Gate Configuration

Sets the start measuring time for the selected gate.

Remote command:

`POWer: INRush: GATE<m>: START` on page 1100

Stop time ← Gate Configuration

Sets the stop measuring time for the selected gate.

Remote command:

`POWer: INRush: GATE<m>: STOP` on page 1100

Report comment

In this field you can write a comment that will be displayed in the measurement report, for example, a measurement description.

Execute

Starts the "Inrush Current " measurement.

Remote command:

`POWer: INRush: EXECute` on page 1099

18.5 Current Harmonic

Current harmonics appear in an electric power system due to non linear electric loads. The harmonics can be ejected back into the AC line and disturb other equipment on the grid. In order to avoid this disturbance there are often standards of compliance that consumer or industry end-products should meet.

The "Current Harmonic" analysis tests the devices according to the pre-compliance standards EN 61000-3-2, MIL-STD-1399 and RTCA DO-160F.

Required probes:

- Differential voltage probe
- Current probe

18.5.1 Current Harmonic Results

The results of "Current Harmonic" measurements are provided in two ways:

- The diagram shows the graphical presentation of:
 - the voltage waveform
 - the current waveform
 - the power waveform

- The result box displays a bar chart or a table with the numerical measurement results up to the 40th harmonics.

To switch the display, tap "Show table" or "Show plot" accordingly

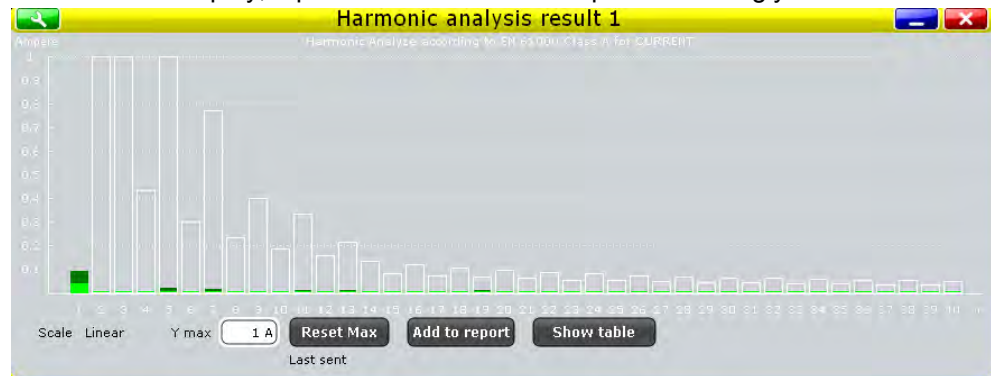

Harmonic index	Frequency	Value	Maximum	Standard limit
1	50 Hz	34.235 mA	89.068 mA	0 A
2	99.9 Hz	2 µA	68 µA	1.08 A
3	149.9 Hz	3 µA	3.827 mA	2.3 A
4	199.8 Hz	3 µA	75 µA	430 mA
5	249.8 Hz	4 µA	15.009 mA	1.14 A
6	299.8 Hz	4 µA	69 µA	300 mA
7	349.7 Hz	3 µA	13.406 mA	770 mA
8	399.7 Hz	3 µA	74 µA	230 mA
9	449.6 Hz	4 µA	3.659 mA	400 mA
10	499.6 Hz	2 µA	85 µA	184 mA
11	549.5 Hz	4 µA	5.035 mA	330 mA
12	599.5 Hz	4 µA	75 µA	153.333 mA
13	649.5 Hz	4 µA	7.677 mA	210 mA
14	699.4 Hz	5 µA	84 µA	131.429 mA
15	749.4 Hz	4 µA	3.622 mA	80 mA

To measure and display the current harmonic, the instrument uses the following measurements and waveforms:

- "P6" Meas 6 to measure the power waveform
- "P7" Meas 7 to measure the spectrum voltage
- "P8" Meas 8 to measure the spectrum current
- "M2" Math 2 to calculate the power
- "M3" Math 3 to calculate the FFT of the voltage
- "M4" Math 4 to calculate the FFT of the current

The used resources are listed in the "Details" tab. See also: [chapter 18.2.3, "Details Tab"](#), on page 575.

The current harmonic results are defined as follows:

Result Table	Bar Chart Match	Description
Harmonic Index	Value of the X-Axis	The harmonic order
Frequency	-	The frequency value of the signal
Value	Value of the Y-Axis. Shown by a green bar	The present value of the current harmonic
Maximum	Shown by a darkened green bar	The maximum measured value

Result Table	Bar Chart Match	Description
Standard limit	Shown by a white bar	The maxim allowed value according to the selected standard
"Y max"	"Y max"	Sets the upper limit for the display of the Y scale. This value can be reset with the "Reset Max" button

The following remote commands are used for handling the measurement results:

- `POWer:HARMonics:RESult<m>:FREQuency<n>:VALue?` on page 1102
- `POWer:HARMonics:RESult<m>:MAXValue<n>:VALue?` on page 1102
- `POWer:HARMonics:RESult<m>:STDinuse?` on page 1102
- `POWer:HARMonics:RESult<m>:STDValue<n>:VALue?` on page 1102
- `POWer:HARMonics:RESult<m>:VALue<n>:VALue?` on page 1102
- `POWer:HARMonics:REPort:ADD` on page 1102

18.5.2 Configuring Current Harmonic

For details of the configuration settings, see [chapter 18.5.3, "Current Harmonic Settings"](#), on page 587.

1. Select "Analysis">"Power".
2. Under "Power Analysis", select "Current Harmonic".
3. Connect the differential voltage probe and the current probe to the oscilloscope.
4. Deskew the probes as described in [chapter 18.1.1.1, "Auto Deskew"](#), on page 563.
5. Connect the probes to the DUT as shown in the "Channels" tab:

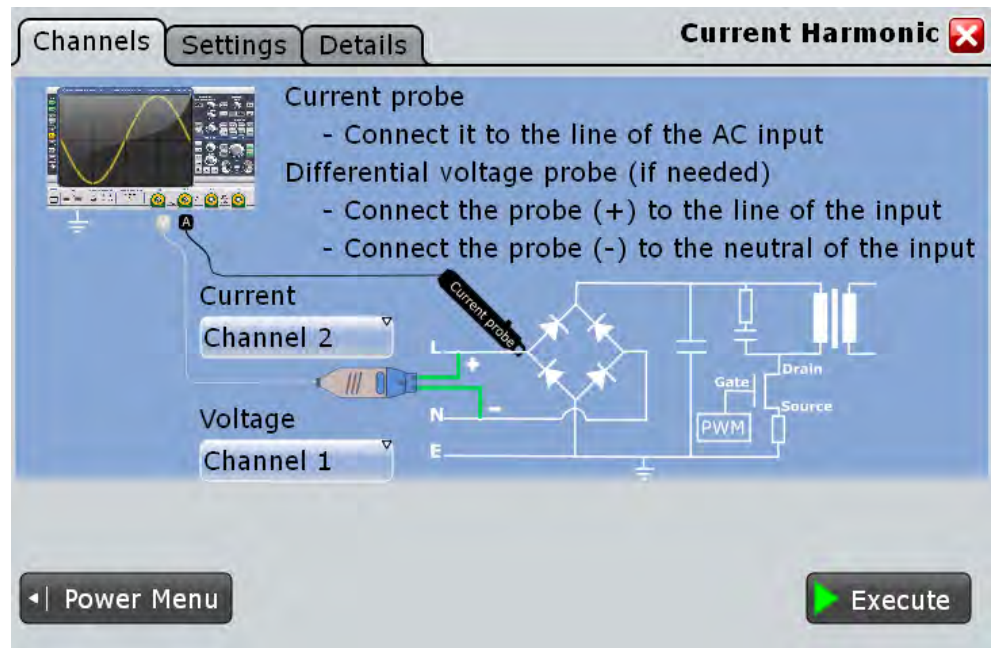

6. Select the correct channels for the "Current Source" and the "Voltage Source".
7. Select the "Settings" tab.
8. Set the "Standard in use"
9. Set the "Frequency" according to your signal.
10. Select an "Optimize Scaling" option.
11. Tap "Execute".

On the screen you can see the measurement of the current, the voltage and the power. Additionally there is a table giving information about important measurement parameters. For details, see [chapter 18.5.1, "Current Harmonic Results"](#), on page 584.

18.5.3 Current Harmonic Settings

In the "Channels" tab, you set the current source and the voltage source, see also: [chapter 18.2.1, "Channels Tab"](#), on page 573.

In the "Settings" tab you configure the current harmonic measurement parameters and display settings.

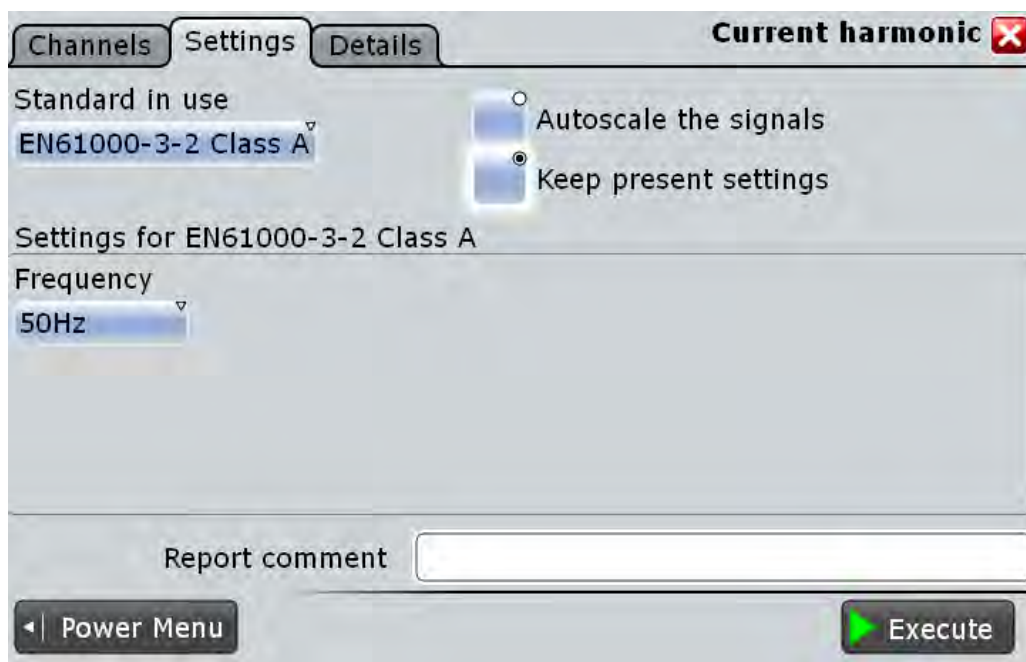

Standard in use

Select the standard in use. For a list of the available standards, see [table 18-1](#).

Table 18-1: Current Harmonic pre-compliance standards

Standard	Application
EN 61000-3-2 Class A	Balanced 3-phase equipment, household appliances (excluding equipment identified as class D), tools (excluding portable tools), dimmers for incandescent lamps, audio equipment
EN 61000-3-2 Class B	Portable tools, not professional arc welding equipment
EN 61000-3-2 Class C	Lighting equipment
EN 61000-3-2 Class D	PC, PC monitors, radio, or TV receivers with an input power less than or equal to 600W
MIL-STD-1399	Military shipboard user equipment
RTCA DO-160	Environmental tests of avionics hardware

Remote command:

[POWER:HARMonics:STAN](#) on page 1102

Frequency

Selects the frequency of the input signal.

Remote command:

[POWER:HARMonics:ENFR](#) on page 1101

[POWER:HARMonics:MIFR](#) on page 1101

[POWER:HARMonics:DOFR](#) on page 1101

Revised Current

Available only for "Standard" > "RTCA DO-160".

Selects how the results are evaluated. Available are the following settings:

- Evaluation with current source only
- Evaluation with voltage source and revised current law
 - Display opposite voltage harmonic result chart
 - Do not display voltage result

Remote command:

`POWer:HARMonics:EVAL` on page 1101

`POWer:HARMonics:VOLT` on page 1102

Optimize scaling

Selects the scaling for the display of the results.

"Autoscale the signals"

Automatically selects the most appropriate scale for the display of the results.

"Keep present settings"

The present display settings are not changed.

Remote command:

`POWer:HARMonics:AUTO` on page 1101

Report comment

In this field you can write a comment that will be displayed in the measurement report, for example, a measurement description.

Execute

Starts the "Current Harmonics" measurement.

Remote command:

`POWer:HARMonics:EXECute` on page 1102

18.6 Modulation Analysis

The "Modulation Analysis " measures the control pulse signal to a switching device.

Required probes:

- Differential voltage probe
- Current probe

18.6.1 Modulation Analysis Results

The results of "Modulation Analysis " measurements are provided in two ways:

- The diagram shows the graphical presentation of:
 - the voltage or the current waveform
 - for "Type >Turn on" a track of the frequency and the duty cycle.

- (Optional for "Type > Continuous" measurement) Two histograms display the density distribution of the measurement results in dependence of the frequency and the positive duty cycle.
- The result box displays the numeric measurement results.

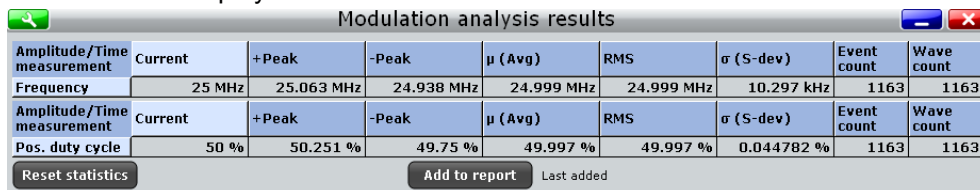

Amplitude/Time measurement	Current	+Peak	-Peak	μ (Avg)	RMS	σ (S-dev)	Event count	Wave count
Frequency	25 MHz	25.063 MHz	24.938 MHz	24.999 MHz	24.999 MHz	10.297 kHz	1163	1163
Amplitude/Time measurement	Current	+Peak	-Peak	μ (Avg)	RMS	σ (S-dev)	Event count	Wave count
Pos. duty cycle	50 %	50.251 %	49.75 %	49.997 %	49.997 %	0.044782 %	1163	1163

Reset statistics Add to report Last added

To measure and display the power quality, the instrument uses the following measurements and waveforms:

- "P7" Meas 7 to measure the positive duty cycle
- "P8" Meas 8 to measure the frequency

The used resources are listed in the "Details" tab. See also: [chapter 18.2.3, "Details Tab"](#), on page 575.

Table 18-2: Statistic result parameters

Label	Description
Current	Currently measured value
+Peak	Positive peak value (maximum)
-Peak	Negative peak value (minimum)
μ (Avg)	Average
RMS	Root mean square
σ (S-dev)	Standard deviation
Event count	Number of measured pulses
Wave count	Number of waveforms (acquisitions) the measurement is based on

"Modulation Analysis" is a statistical evaluation that will be reset only if the measurement setup is changed or you reset the statistics.

The following remote commands are used for handling the measurement results:

- `POWer:MODulation:RESult:ACTual?` on page 1104
- `POWer:MODulation:RESult:AVG?` on page 1104
- `POWer:MODulation:RESult:EVTCount?` on page 1104
- `POWer:MODulation:RESult:NPEak?` on page 1104
- `POWer:MODulation:RESult:PPEak?` on page 1104
- `POWer:MODulation:RESult:RMS?` on page 1104
- `POWer:MODulation:RESult:STDDev?` on page 1104
- `POWer:MODulation:RESult:WFMCCount?` on page 1104
- `POWer:MODulation:REPort:ADD` on page 1103

18.6.2 Configuring Modulation Analysis

For details of the configuration settings, see [chapter 18.6.3, "Modulation Analysis Settings"](#), on page 591.

1. Select "Analysis" > "Power".
2. Under "Switching / Control Loop" select "Modulation Analysis".
3. Connect the differential voltage probe and the current probe to the oscilloscope.
4. Deskew the probes as described in [chapter 18.1.1.1, "Auto Deskew"](#), on page 563.
5. Connect the probes to the DUT as shown in the "Channels" tab:

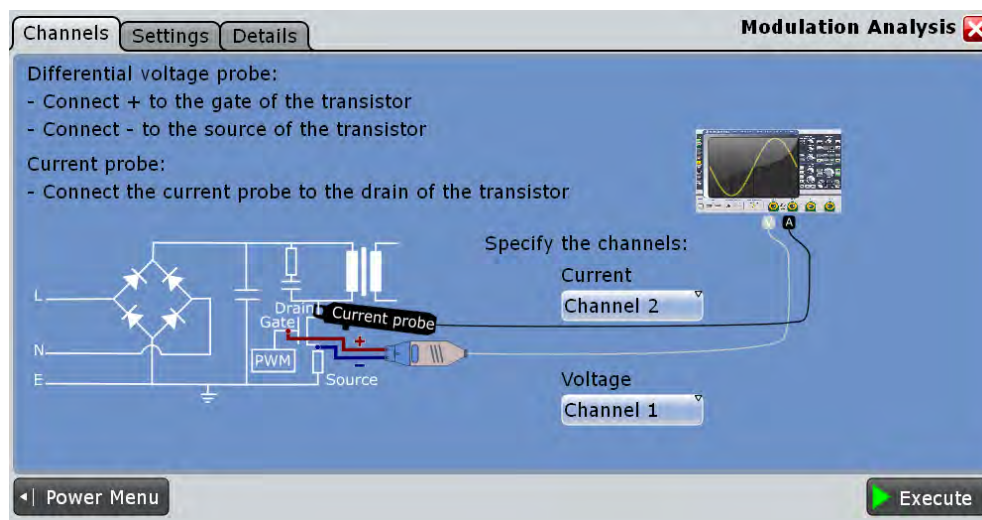

6. Select the correct channels for the "Current Source" and the "Voltage Source".
7. Select the "Settings" tab.
8. Set the "Source" and the "Type" of measurement.
9. Select an "Optimize Scaling" option.
10. Tap "Execute".

On the screen you can see the measurement waveforms of the current or the voltage. Additionally, the result box with numeric measurement results is shown. For details, see [chapter 18.6.1, "Modulation Analysis Results"](#), on page 589.

18.6.3 Modulation Analysis Settings

In the "Channels" tab, you set the current source and the voltage source, see also: [chapter 18.2.1, "Channels Tab"](#), on page 573.

In the "Settings" tab you configure the modulation analysis parameters and display settings.

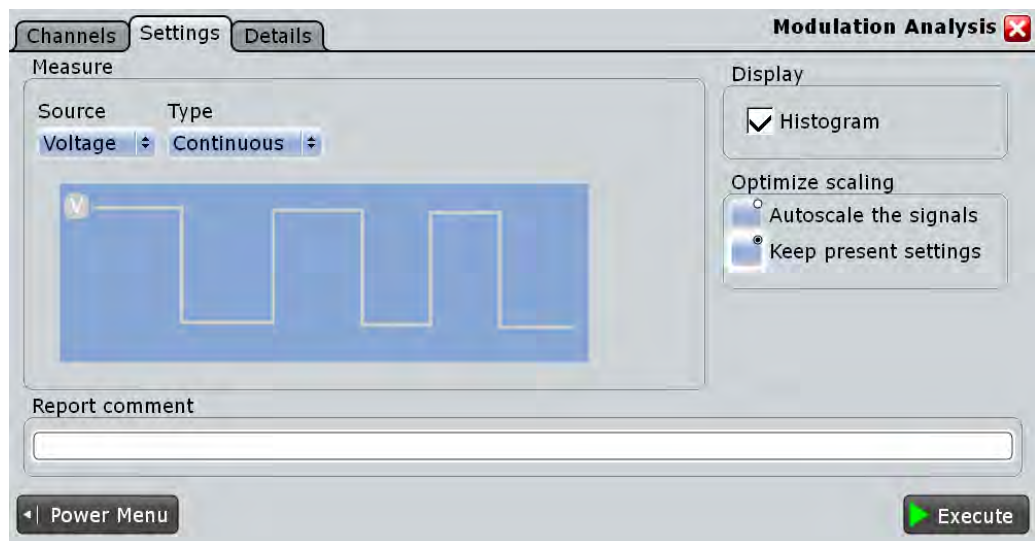
**Source**

Selects the source for the measurement.

Remote command:

[POWER:MODulation:SOURce](#) on page 1104

Type

Selects the type of signal flow for the measurement

"Continuous" The measurement is running continuously.

"Turn on" The measurement runs once when the DUT is turned on.

Remote command:

[POWER:MODulation:TYPE](#) on page 1104

Display Histogram

Available only for "Type" > "Continuous".

Enables the display of two histograms after the measurement is executed. The histograms show the density distribution of the measurement results in dependence of the frequency/ duty cycle in a graphic. Thus they illustrate the statistics of the measurements.

Remote command:

[POWER:MODulation:DHISTogram](#) on page 1103

Optimize scaling

Selects the scaling for the display of the results.

"Autoscale the signals"

Automatically selects the most appropriate scale for the display of the results.

"Keep present settings"

The present display settings are not changed.

Remote command:

[POWER:MODulation:AUTO](#) on page 1103

Report comment

In this field you can write a comment that will be displayed in the measurement report, for example, a measurement description.

Execute

Starts the "Modulation Analysis" measurement.

Remote command:

`POWer:MODulation:EXECute` on page 1103

18.7 Dynamic On Resistance

The "Dynamic ON Resistance" analysis measures the resistance of a switching device, during operation. Because voltage and current may vary in time, the resistance is not constant, thus it is called dynamic ON resistance. It is defined as the ratio dV/dI .

The resistance-related voltage should be measured during a stable part of the switch node waveform, when the undershoot and ringing have decayed, after the high-to-low voltage transition.

Required probes:

- Differential voltage probe
- Current probe

18.7.1 Dynamic On Resistance Results

The results of "Dynamic On Resistance" measurements are provided in two ways:

- The diagram shows the graphical presentation of:
 - the voltage waveform
 - the current waveform
- The result box displays the dynamic on resistance value.



To measure and display the dynamic on resistance, the instrument uses the following measurements and waveforms:

- "P5" Meas 5 to measure the amplitude of the voltage
- "P6" Meas 6 to measure the amplitude of the voltage
- "P7" Meas 7 to measure the amplitude of the current
- "P8" Meas 8 to measure the amplitude of the current
- "C1 " Cursor 1 to measure gate ["t₀" , "t₁"]
- "C2 " Cursor 2 to measure gate ["t₂" , "t₃"]

The used resources are listed in the "Details" tab. See also: [chapter 18.2.3, "Details Tab"](#), on page 575.

The dynamic on resistance displayed as the result is defined as:

$$R = \frac{V(t_2) - V(t_0)}{I(t_3) - I(t_1)}$$

The points "t₀", "t₁", "t₂" and "t₃" are defined by the cursor lines displayed in the result diagram of the measurement. You can move the cursor lines to define another area of interest.

The following remote commands are used for handling the measurement results:

- `POWer:DONRes:RESult:RESistance?` on page 1105
- `POWer:DONRes:GATE<m>:START` on page 1105
- `POWer:DONRes:GATE<m>:STOP` on page 1105
- `POWer:DONRes:REPort:ADD` on page 1105

18.7.2 Configuring Dynamic On Resistance

For details of the configuration settings, see [chapter 18.7.3, "Dynamic On Resistance Settings"](#), on page 595.

1. Select "Analysis" > "Power".
2. Under "Switching / Control Loop" select "Dynamic On Resistance".
3. Connect the differential voltage probe and the current probe to the oscilloscope.
4. Deskew the probes as described in [chapter 18.1.1.1, "Auto Deskew"](#), on page 563.
5. Connect the probes to the DUT as shown in the "Channels" tab:

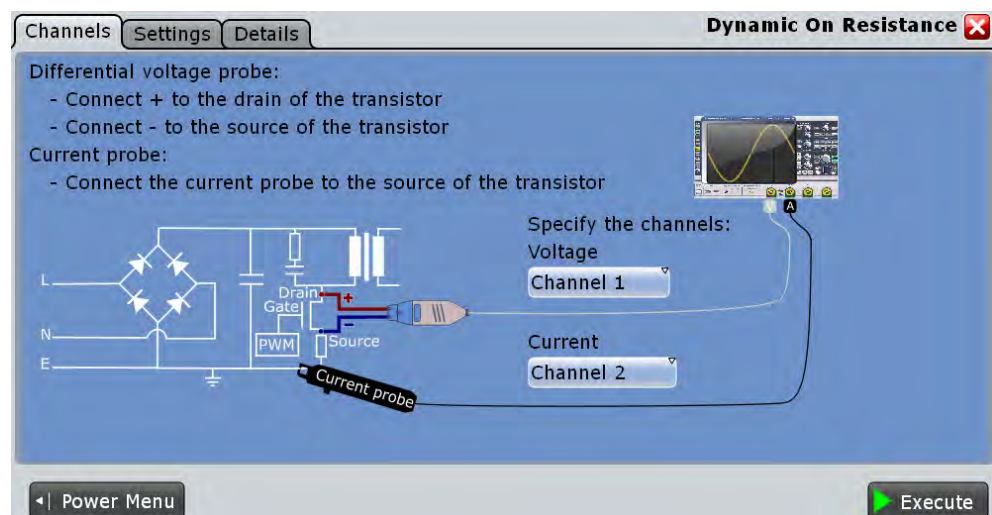

6. Select the correct channels for the "Current Source" and the "Voltage Source".
7. Select the "Settings" tab.

8. If "Average" is selected, enter the "Average count", that is the number of waveforms used for average calculation.
9. Set the reset condition for the average calculation:
 - If "Time" is selected, enter the "Reset time".
 - If "Waveforms" is selected, enter the "Reset count".
10. Select an "Optimize Scaling" option.
11. Tap "Execute".
12. If needed adjust the cursors manually. You can tap on a cursor and change its position with the NAVIGATION ROTARY KNOB.

On the screen you can see the measurement waveforms of the current and the voltage. Additionally, the result box displays the dynamic on resistance. For details, see [chapter 18.7.1, "Dynamic On Resistance Results"](#), on page 593.

18.7.3 Dynamic On Resistance Settings

In the "Channels" tab, you set the current source and the voltage source, see also: [chapter 18.2.1, "Channels Tab"](#), on page 573.

In the "Settings" tab you configure the power measurement parameters and display settings.

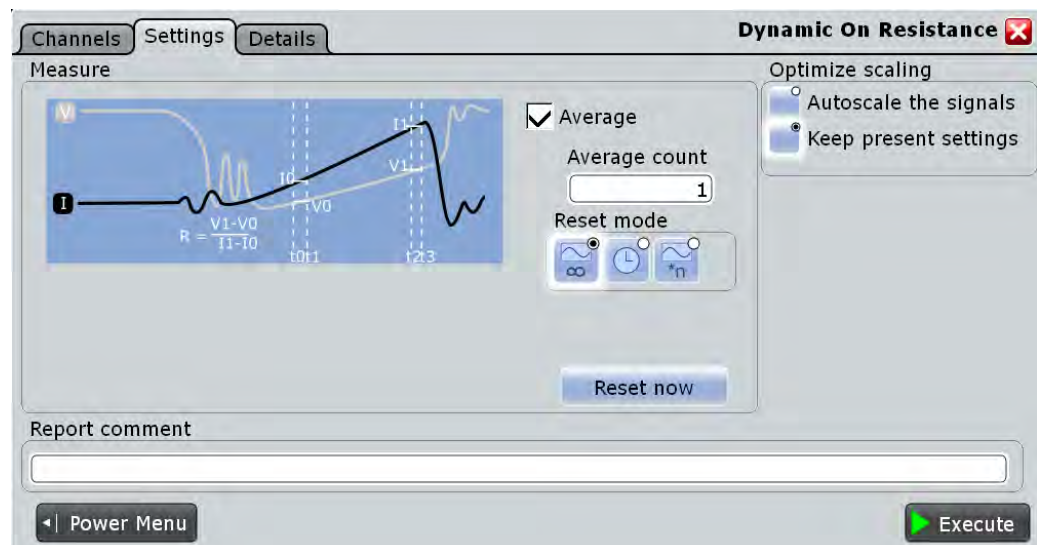

Average

Enables the "Average" method for building the resulting waveform. The average is calculated from the data of the current acquisition and a number of acquisitions before. The method reduces random noise and other heterodyne signals. It requires a stable, triggered and periodic signal for correct function. The number of acquisitions for average calculation is defined with "Average count", and the "Reset mode" defines the restart condition.

Remote command:

[POWer: DONRes:AVG](#) on page 1105

**Reset mode**

Defines when the envelope and average evaluation restarts.



"None" No restart, the number of acquisitions considered by the waveform arithmetics is not limited.



"Time" Restarts the envelope and average calculation after the time defined in "Reset time".



"Waveforms" Restarts the envelope and average calculation after a number of acquired waveforms defined in "Reset count".

Remote command:

[ACQuire:ARESet:MODE](#) on page 684

[ACQuire:ARESet:TIME](#) on page 684

[ACQuire:ARESet:WFMCOUNT](#) on page 684

Reset Now

Forces the immediate restart of the envelope and average calculation for all waveforms, ignoring the reset settings.

Remote command:

[ACQuire:ARESet:IMMediate](#) on page 683

Optimize scaling

Selects the scaling for the display of the results.

"Autoscale the signals"

Automatically selects the most appropriate scale for the display of the results.

"Keep present settings"

The present display settings are not changed.

Remote command:

[POWer: DONRes:AUTO](#) on page 1105

Report comment

In this field you can write a comment that will be displayed in the measurement report, for example, a measurement description.

Execute

Starts the "Dynamic On Resistance" measurement.

Remote command:

`POWer:DONRes:EXECute` on page 1105

18.8 Slew Rate

The "Slew Rate" analysis measures the rate of change of the voltage or current waveform during the switching of the switching transistor.

Required probes:

- Differential voltage probe
- Current probe

18.8.1 Slew Rate Results

The results of "Slew Rate" measurements are provided in two ways:

- The diagram shows the graphical presentation of:
 - the voltage waveform
 - the current waveform
 - a waveform of the derivative of voltage and current
- The result box displays the numeric measurement results. For a detailed description, see [table 18-2](#).



Slew rate results								
Amplitude/Time measurement	Current	+Peak	-Peak	μ (Avg)	RMS	σ (S-dev)	Event count	Wave count
Max	20.769 MV*Hz	39.526 MV*Hz	20.123 MV*Hz	21.417 MV*Hz	21.475 MV*Hz	1.5773 MV*Hz	4614	4614
Min	-21.155 MV*Hz	-20.083 MV*Hz	-39.526 MV*Hz	-21.542 MV*Hz	21.601 MV*Hz	1.6011 MV*Hz	4614	4614

Reset statistics Add to report Last added

To measure and display the slew rate, the instrument uses the following measurements and waveforms:

- "P8" Meas 8 to measure the amplitude of the current or voltage waveform
- "M2" Math 4 to calculate the time derivative of the current or voltage waveform
- "C1" Cursor 1 to determine the measurement area

The used resources are listed in the "Details" tab. See also: [chapter 18.2.3, "Details Tab"](#), on page 575.

The following remote commands are used for handling the measurement results:

- `POWer:SLEWrate:RESult:ACTual?` on page 1107
- `POWer:SLEWrate:RESult:AVG?` on page 1107
- `POWer:SLEWrate:RESult:EVTCount?` on page 1107
- `POWer:SLEWrate:RESult:NPEak?` on page 1107
- `POWer:SLEWrate:RESult:PPEak?` on page 1107

- [POWER:SLEWrate:RESult:RMS?](#) on page 1107
- [POWER:SLEWrate:RESult:STDDev?](#) on page 1107
- [POWER:SLEWrate:RESult:WFMCCount?](#) on page 1107
- [POWER:SLEWrate:REPort:ADD](#) on page 1107

18.8.2 Configuring Slew Rate

For details of the configuration settings, see [chapter 18.8.3, "Slew Rate Settings"](#), on page 599.

1. Select "Analysis" > "Power".
2. Under "Switching / Control Loop" dialog select "Slew Rate".
3. Connect the differential voltage probe and the current probe to the oscilloscope.
4. Deskew the probes as described in [chapter 18.1.1.1, "Auto Deskew"](#), on page 563.
5. Connect the probes to the DUT as shown in the "Channels" tab:

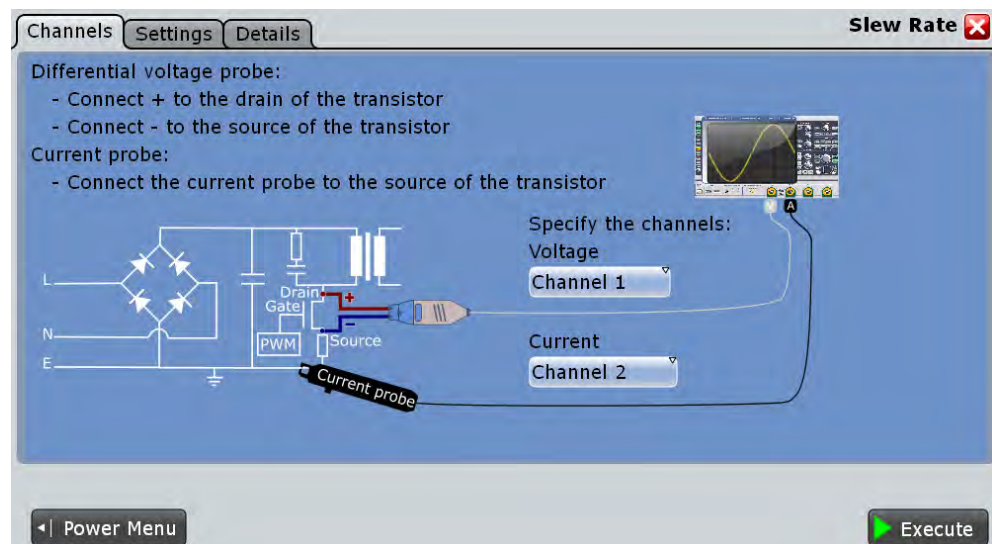

6. Select the correct channels for the "Current Source" and the "Voltage Source".
7. Select the "Settings" tab.
8. Select the "Source".
9. If "Average" is selected, enter the "Average count", that is the number of waveforms used for average calculation.
10. Set the reset condition for the average calculation:
 - If "Time" is selected, enter the "Reset time".
 - If "Waveforms" is selected, enter the "Reset count".
11. Select an "Optimize Scaling" option.

12. Tap "Execute".

On the screen you can see the measurement waveforms of the slew rate, the current and the voltage. The result box with numeric measurement results is shown. For details, see [chapter 18.8.1, "Slew Rate Results"](#), on page 597.

18.8.3 Slew Rate Settings

In the "Channels" tab, you set the current source and the voltage source, see also: [chapter 18.2.1, "Channels Tab"](#), on page 573.

In the "Settings" tab you configure the slew rate measurement parameters and display settings.

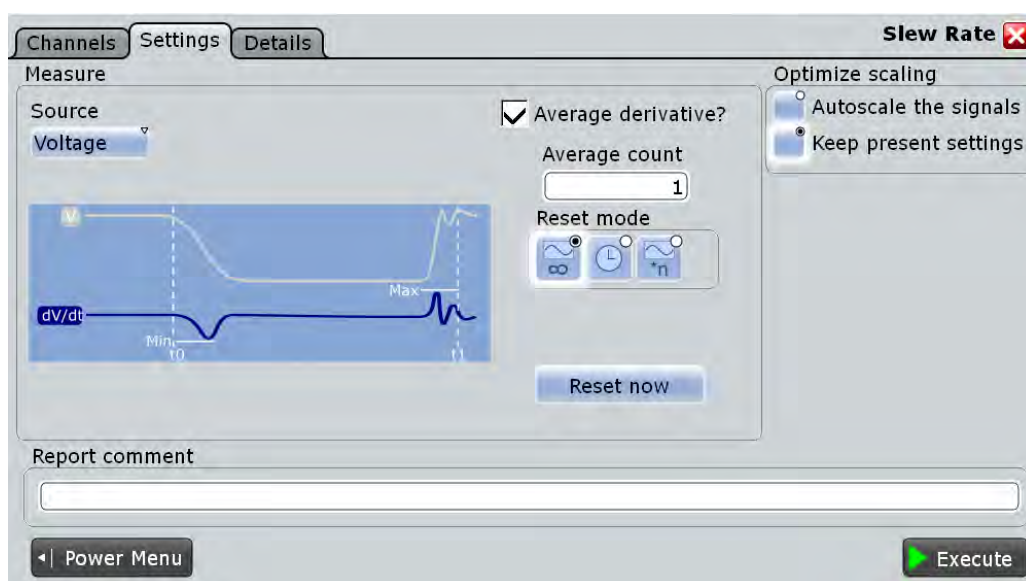

Source

Selects dV/dt or dI/dt as the source of the measurement.

Remote command:

`POWER:SLEWrate:SOURce` on page 1107

Average

Enables the "Average" method for building the resulting waveform. The average is calculated from the data of the current acquisition and a number of acquisitions before. The method reduces random noise and other heterodyne signals. It requires a stable, triggered and periodic signal for correct function. The number of acquisitions for average calculation is defined with "Average count", and the "Reset mode" defines the restart condition.

Remote command:

`POWER:SLEWrate:AVGDeriv` on page 1106



Reset mode

Defines when the envelope and average evaluation restarts.



"None" No restart, the number of acquisitions considered by the waveform arithmetics is not limited.



"Time" Restarts the envelope and average calculation after the time defined in "Reset time".

"Waveforms" Restarts the envelope and average calculation after a number of acquired waveforms defined in "Reset count".

Remote command:

[ACQUIRE:ARESet:MODE](#) on page 684

[ACQUIRE:ARESet:TIME](#) on page 684

[ACQUIRE:ARESet:WFMCOUNT](#) on page 684

Reset Now

Forces the immediate restart of the envelope and average calculation for all waveforms, ignoring the reset settings.

Remote command:

[ACQUIRE:ARESet:IMMEDIATE](#) on page 683

Optimize scaling

Selects the scaling for the display of the results.

"Autoscale the signals"

Automatically selects the most appropriate scale for the display of the results.

"Keep present settings"

The present display settings are not changed.

Remote command:

[POWER:SLEWrate:AUTO](#) on page 1106

Report comment

In this field you can write a comment that will be displayed in the measurement report, for example, a measurement description.

Execute

Starts the "Slew Rate" measurement.

Remote command:

[POWER:SLEWrate:EXECUTE](#) on page 1106

18.9 Safe Operating Area (S.O.A.)

The safe operating area is defined by the voltage and current conditions over which a power semiconductor device is expected to operate without self-damage. The "Safe Operating Area" analysis provides a diagram of the safe operating conditions of your device.

Required probes:

- Differential voltage probe

- Current probe

18.9.1 Safe Operating Area Results

The results of "Safe Operating Area" measurements are provided in the following ways:

- The diagram shows the graphical presentation of:
 - the voltage waveform
 - the current waveform
- A logarithmic or linear XY diagram of the calculated voltage (x-axis) and current (y-axis) waveforms. This curve is a graphical representation of the power handling capability of the device under various conditions.
- The result box displays the numeric measurement results. Additionally, you can see the mask definition and change the scale in the "SOA Control" dialog. If the state of "Enable mask test" is "On" an extra result box appears, see also [table 18-3](#).

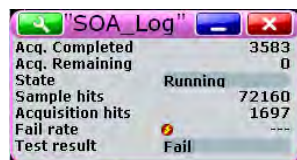

To measure and display the safe operating area, the instrument uses the following measurements and diagrams:

- "XY1" XY Diagram 1 to measure the logarithmic waveform
- "XY2" XY Diagram 2 to measure the linear waveform
- "M1" Math 1 to calculate the voltage signal
- "M2" Math 2 to calculate the current signal

The used resources are listed in the "Details" tab. See also: [chapter 18.2.3, "Details Tab"](#), on page 575.

The results of the safe operating area mask test are described in [table 18-3](#).

Table 18-3: Results of the mask test

Result	Description
Acq. completed	Number of tested acquisitions
Acq. remaining	Remaining acquisitions until "Average count / Nx Single count" is reached
State	Shows if the test has been completed. The state is set to "Finished" when "Nx Single count" acquisitions are tested and the number of "Acq. remaining" is 0. As long as the number of tested acquisitions is less the "Nx Single count" number, the state is "Running". If you run the acquisition with RUN CONT, or the number of played history acquisitions exceeds "Nx Single count", the mask testing is performed according to fail criteria settings independently of the test state. The testing is not stopped when the state is set to "Finished".
Sample hits	Number of samples that hit the mask
Acquisition hits	Number of acquisitions that contained at least one sample hit
Fail rate	Ratio of acquisition hits to the number of tested acquisitions
Test result	A test has failed if the number of sample hits or acquisition hits exceeds the limit of "Violation tolerance" hits

The following remote commands are used for handling the measurement results:

- `POWer:SOA:SWITCh` on page 1110
- `POWer:SOA:REPort:ADD` on page 1109

18.9.2 Configuring Safe Operating Area

For details of the configuration settings, see [chapter 18.9.3, "Safe Operating Area Settings"](#), on page 603.

1. Select "Analysis" > "Power".
2. Under "Power Path", select "Safe Operating Area".
3. Connect the differential voltage probe and the current probe to the oscilloscope.
4. Deskew the probes as described in [chapter 18.1.1.1, "Auto Deskew"](#), on page 563.
5. Connect the probes to the DUT as shown in the "Channels" tab:

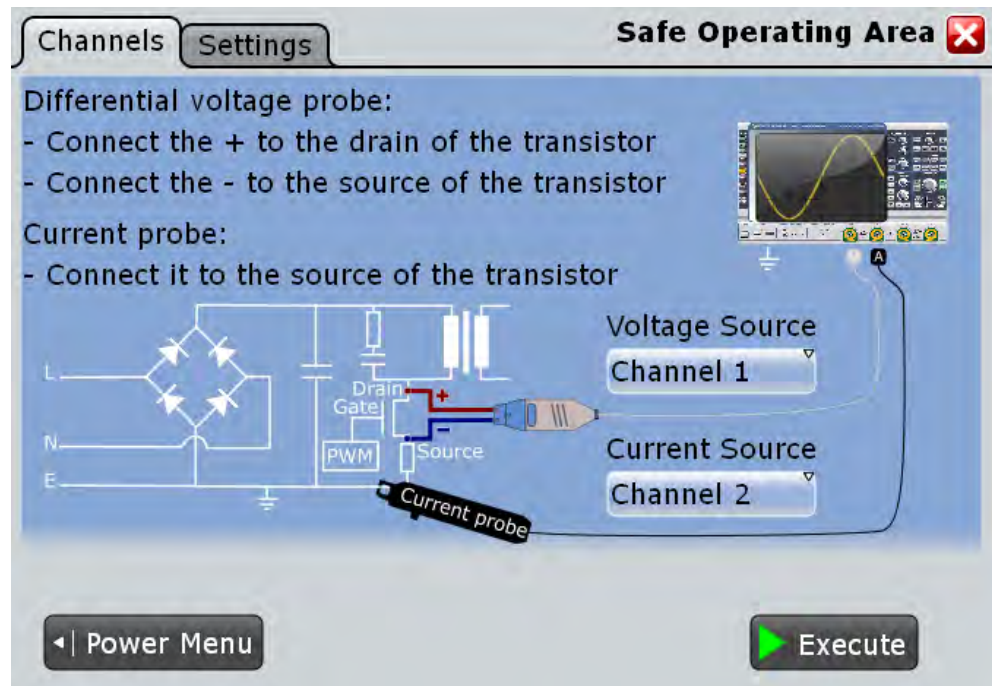

6. Select the correct channels of the "Current Source" and the "Voltage Source".
7. Select the "Settings" tab.
8. Select the state of the "Enable mask test".
9. Select the "Scale".
10. Define the SOA Points.
11. Tap "Execute".

On the screen you can see the measurement waveforms of the Additionally, the result box with numeric measurement results is shown. For details, see [chapter 18.9.1, "Safe Operating Area Results"](#), on page 601.

18.9.3 Safe Operating Area Settings

In the "Channels" tab, you set the current source and the voltage source, see also: [chapter 18.2.1, "Channels Tab"](#), on page 573.

In the "Settings" tab you configure the safe operating area parameters and display settings.

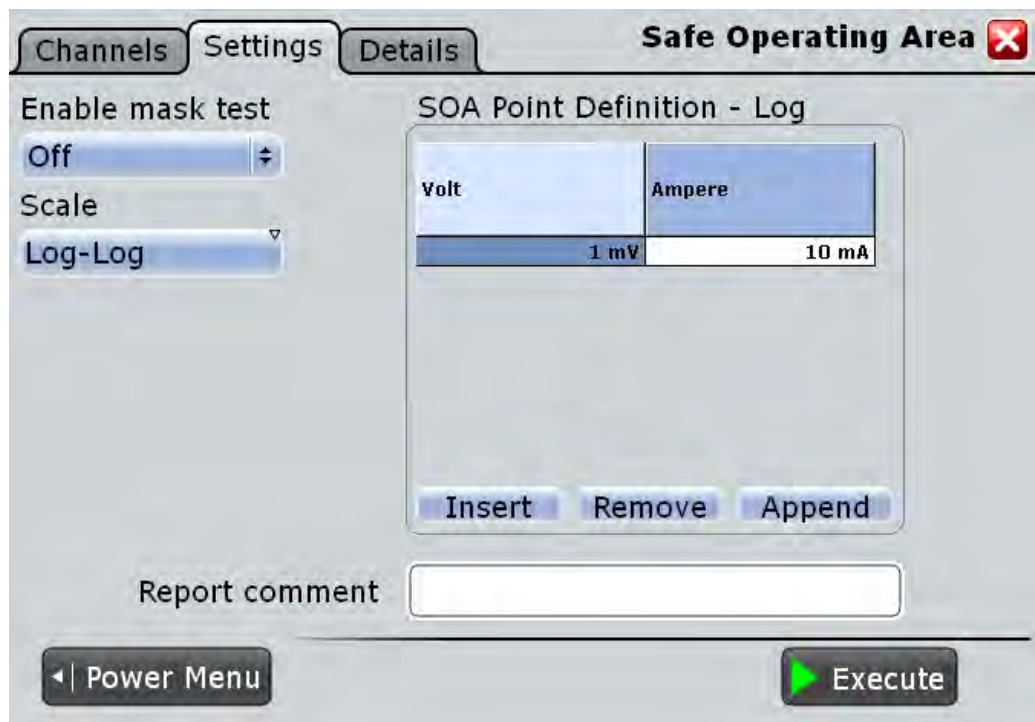
**Enable mask test**

Enables a mask test.

Remote command:

[POWer:SOA:MASK](#) on page 1109

Scale

Selects the scale for the result diagram.

Remote command:

[POWer:SOA:SCALE](#) on page 1110

SOA point definition

To add a point press "Insert" or "Append". To remove a point press "Remove".

Remote command:

[POWer:SOA:LINear:ADD](#) on page 1108

[POWer:SOA:LOGarithmic:ADD](#) on page 1108

[POWer:SOA:LINear:COUNT?](#) on page 1108

[POWer:SOA:LOGarithmic:COUNT?](#) on page 1108

[POWer:SOA:LINear:INSert](#) on page 1109

[POWer:SOA:LOGarithmic:INSert](#) on page 1109

[POWer:SOA:LINear:REMove](#) on page 1108

[POWer:SOA:LOGarithmic:REMove](#) on page 1108

Volt ← SOA point definition

Sets the voltage value of the SOA point.

Remote command:

[POWer:SOA:LINear:POINt<m>:VOLTag](#) on page 1109

Ampere ← SOA point definition

Sets the current value of the SOA point.

Remote command:

[POWer:SOA:LINear:POINt<m>:CURRent](#) on page 1109

Report comment

In this field you can write a comment that will be displayed in the measurement report, for example, a measurement description.

Execute

Starts the "Safe Operating Area" measurement.

Remote command:

[POWer:SOA:EXECute](#) on page 1108

18.10 Turn On/ Off

"Turn On/Off" analysis measures how fast a power supply takes to reach a certain percentage of the steady state output level when initially turned on or turned off.

Common measuring scenarios include:

- Turn on time: measurement of the time it takes for the DC output to reach 90 % of the expected steady state level, after the power supply is initially turned on.
- Turn off time: measurement of the time it takes for the DC output to reach 10 % of the expected steady state level, after the power supply is initially turned off.

Required probes:

- Differential voltage probe
- Passive or differential voltage probe

18.10.1 Turn On/ Off Results

The results of "Turn On/ Off" measurements are provided in two ways:

- The diagram shows the graphical presentation of:
 - the input voltage waveform
 - the output voltage waveform
- The result box displays the "Turn on time" or the "Turn off time".



To measure and display the turn on and turn off time, the instrument uses the following measurements and waveforms:

- "P8" Meas 8 to measure the delay time.

The used resources are listed in the "Details" tab. See also: [chapter 18.2.3, "Details Tab"](#), on page 575.

The "Turn on time" is measured as the time between the trigger point ("Trigger level on" value is reached) and the time the given percentage of the "Steady state level" is reached, see [figure 18-2](#).

The "Turn off time" is measured as the time between the trigger point, delayed with the set "Time", ("Trigger level on" value is reached) and the time the given percentage of the "Steady state level" is reached, see [figure 18-3](#).

The following remote commands are used for handling the measurement results:

- `POWer:ONOFF:RESult:TOFF?` on page 1111
- `POWer:ONOFF:RESult:TON?` on page 1111
- `POWer:ONOFF:REPort:ADD` on page 1111

18.10.2 Configuring Turn On/ Off

For details of the configuration settings, see [chapter 18.10.3, "Turn On/ Off Settings"](#), on page 607.

1. Select "Analysis">"Power".
2. Under "Power Path", select "Turn On/ Off".
3. Connect the probes to the DUT as shown in the "Channels" tab:

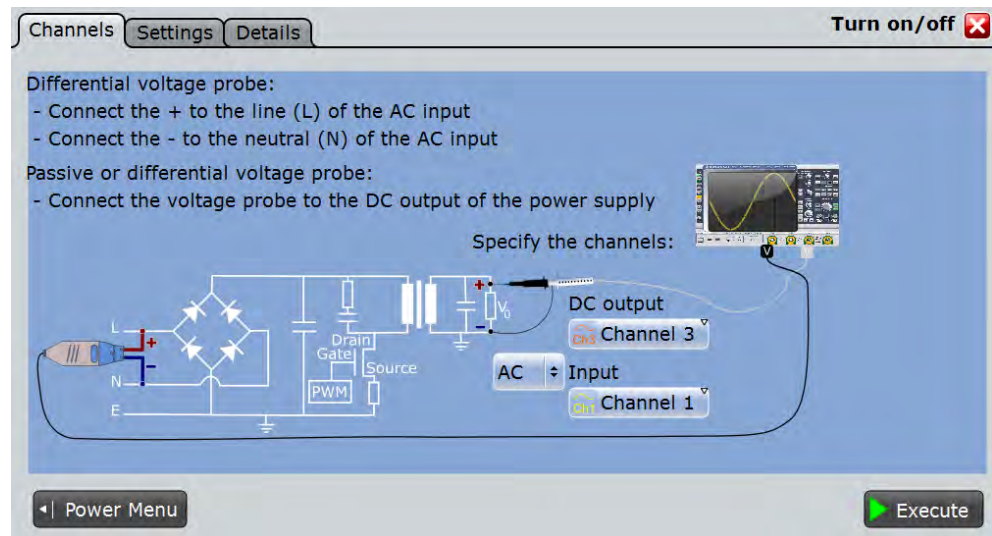

4. Select the correct channels for the "DC output" and the "AC input" or the "DC input".
5. Select the "Settings" tab.
6. Select whether you want to measure "Turn on" or "Turn off".
7. Set the "Steady state level" and the "Trigger level" according to your requirements.
8. Tap "Execute".
9. Turn on/off the DUT.

On the screen you can see the measurement. Additionally, the result box displays the turn on or the turn off time. For details, see [chapter 18.10.1, "Turn On/ Off Results"](#), on page 605.

18.10.3 Turn On/ Off Settings

In the "Channels" tab, you set the current source and the voltage source, see also: [chapter 18.2.1, "Channels Tab"](#), on page 573.

In the "Settings" tab you configure the turn on and the turn off parameters.

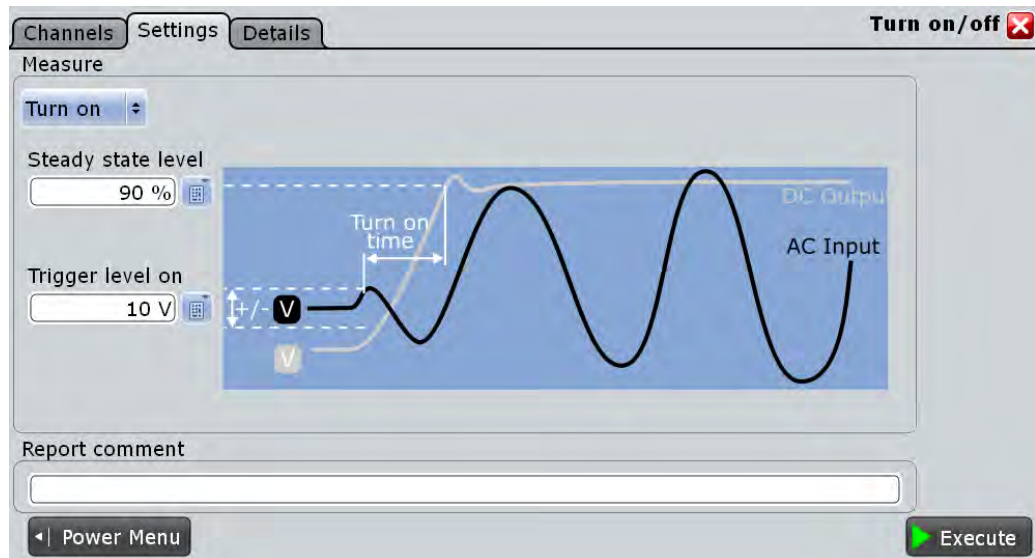

Fig. 18-2: Settings turn on time

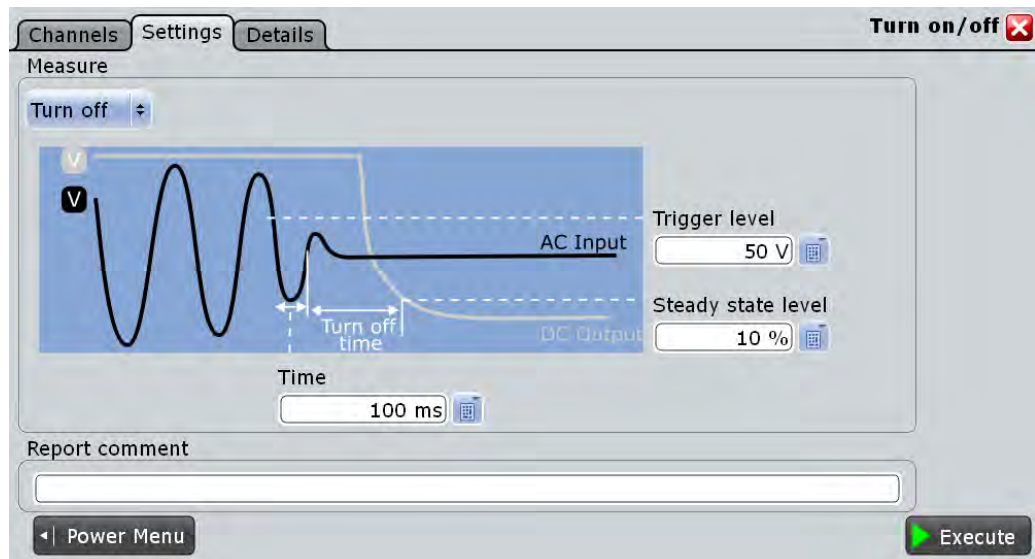

Fig. 18-3: Settings turn off time

Input Type

To access this setting select the "Channels" tab.

Selects the AC or DC input type.

Remote command:

[POWer:ONOff:INPut](#) on page 1111

Measurement Type

Selects the "Turn on" or the "Turn off " measurement.

Remote command:

`POWer:ONOFF:STATE` on page 1112

`POWer:ONOFF:TYPE` on page 1112

Turn on

Enables the configuration of the turn on time measurement.

Steady state level-Turn on ← Turn on

Sets the percentage of the steady state level of the DC output that has to be reached.

Remote command:

`POWer:ONOFF:DSON` on page 1111

Trigger level on ← Turn on

Triggers the beginning of the measurements at the moment the AC or DC input voltage reaches the set value.

Remote command:

`POWer:ONOFF:ATON` on page 1110

`POWer:ONOFF:DTON` on page 1110

Turn off

Enables the configuration of the turn off time measurement.

Steady state level- Turn off ← Turn off

Sets the percentage of the steady state level of the DC output that has to be reached.

Remote command:

`POWer:ONOFF:DSOFF` on page 1111

Trigger level ← Turn off

Triggers the beginning of the measurements at the moment the AC or DC input voltage reaches the set value.

Remote command:

`POWer:ONOFF:ATOFF` on page 1110

`POWer:ONOFF:DTOFF` on page 1110

Time ← Turn off

Sets the time the start of the measurement of the turn off time is delay with, after the trigger point.

Remote command:

`POWer:ONOFF:TIME` on page 1112

Report comment

In this field you can write a comment that will be displayed in the measurement report, for example, a measurement description.

Execute

Starts the "Power Quality" measurement.

Remote command:

POWER:ONOFF:EXECute on page 1111

18.11 Switching Loss

The "Switching Loss" analysis measures the power and energy losses of a switching device, that occur during the switching phases and the conduction phase of the switching transistor.

Required probes:

- Differential voltage probe
- Current probe

18.11.1 Switching Loss Results

The results of "Switching Loss" measurements are provided in two ways:

- The diagram shows the graphical presentation of:
 - the voltage waveform
 - the current waveform
 - the power waveform
- The result box displays the numeric measurement results for the enabled measurement parameters in dependence of the energy and the power. To switch the display, tap "Energy" or "Power" accordingly.

For a detailed description, see [table 18-2](#).

	Current	+Peak	-Peak	μ (Avg)	RMS	σ (S-dev)	Event count	Wave count
Switching frequency	25 MHz	25.063 MHz	24.938 MHz	25.002 MHz	25.002 MHz	14.067 kHz	939	939
Turn on	14.495 pJ	14.764 pJ	14.319 pJ	14.522 pJ	14.522 pJ	55.786 fJ	939	939
Turn off	-150.16 pJ	-149.56 pJ	-150.57 pJ	-150.06 pJ	150.06 pJ	141.46 fJ	939	939
Conduction	52.31 pJ	52.845 pJ	51.932 pJ	52.355 pJ	52.356 pJ	137.34 fJ	939	939
Non conduction	102.36 pJ	103.33 pJ	102.28 pJ	102.79 pJ	102.79 pJ	142.88 fJ	939	939
Total	18.679 pJ	20.02 pJ	18.493 pJ	19.265 pJ	19.267 pJ	249.99 fJ	939	939

	Current	+Peak	-Peak	μ (Avg)	RMS	σ (S-dev)	Event count	Wave count
Switching frequency	25 MHz	25.063 MHz	24.938 MHz	25.001 MHz	25.001 MHz	13.867 kHz	540	540
Turn on	361.31 μW	369.12 μW	358.01 μW	363.07 μW	363.07 μW	1.4188 μW	540	540
Turn off	-3.7435 mW	-3.7421 mW	-3.7645 mW	-3.7518 mW	3.7518 mW	3.4786 μW	540	540
Conduction	1.3109 mW	1.3212 mW	1.2984 mW	1.309 mW	1.309 mW	3.4703 μW	540	540
Non conduction	2.5668 mW	2.5803 mW	2.5585 mW	2.5699 mW	2.5699 mW	3.5069 μW	540	540
Total	487.35 μW	499.66 μW	463.74 μW	481.61 μW	481.65 μW	6.1242 μW	540	540

To measure and display the switching loss, the instrument uses the following measurements and cursors:

- "P3"... "P8": Meas 3 ... Meas 8 to measure the voltage

- "M4" Math 4 to calculate the power
- "C3" Cursor 3 to define time points " t_0 " and " t_1 "
- "C4" Cursor 4 to define time points " t_2 " and " t_3 "

The used resources are listed in the "Details" tab. See also: [chapter 18.2.3, "Details Tab"](#), on page 575.

"Switching Loss" is a statistical evaluation that will be reset only if the measurement setup is changed or you reset the statistics.

The switching loss phases that can be defined during the measurement are shown in [figure 18-4](#) and described in [table 18-4](#).

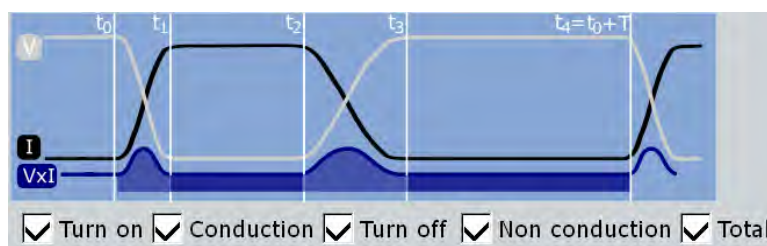

Fig. 18-4: Switching loss phases

Table 18-4: Switching loss phases

Phase	Definition Points	Description
Turn on	The area between " t_0 " and " t_1 "	The time after switching the device, during which the current rises until it reaches the saturation current level.
Conduction	The area between " t_1 " and " t_2 "	The time during which the voltage is at the transistors saturated minimum and the current flows.
Turn off	The area between " t_2 " and " t_3 "	The time during which after a short delay time the voltage rises until it reaches its final value.
Non conduction	The area between " t_3 " and " t_4 "	The time during current doesn't flow. The losses during this period should be theoretically zero.
Total	The area between " t_0 " and " t_4 "	The period of one switching cycle.

The following remote commands are used for handling the measurement results:

- `POWer:SWITching:GATE:COND:START` on page 1114
- `POWer:SWITching:GATE:COND:STOP` on page 1114
- `POWer:SWITching:GATE:NCON:START` on page 1114
- `POWer:SWITching:GATE:NCON:STOP` on page 1114
- `POWer:SWITching:GATE:TOFF:START` on page 1114
- `POWer:SWITching:GATE:TOFF:STOP` on page 1114
- `POWer:SWITching:GATE:TON:START` on page 1114
- `POWer:SWITching:GATE:TON:STOP` on page 1114
- `POWer:SWITching:RESult:ENERgy:ACTual?` on page 1114

- [POWER:SWITChing:RESult:ENERgy:AVG?](#) on page 1114
- [POWER:SWITChing:RESult:ENERgy:EVTCount?](#) on page 1114
- [POWER:SWITChing:RESult:ENERgy:NPEak?](#) on page 1114
- [POWER:SWITChing:RESult:ENERgy:PPEak?](#) on page 1114
- [POWER:SWITChing:RESult:ENERgy:RMS?](#) on page 1114
- [POWER:SWITChing:RESult:ENERgy:STDDev?](#) on page 1114
- [POWER:SWITChing:RESult:ENERgy:WFMCount?](#) on page 1114
- [POWER:SWITChing:RESult:POWER:ACTual?](#) on page 1115
- [POWER:SWITChing:RESult:POWER:AVG?](#) on page 1115
- [POWER:SWITChing:RESult:POWER:EVTCount?](#) on page 1115
- [POWER:SWITChing:RESult:POWER:NPEak?](#) on page 1115
- [POWER:SWITChing:RESult:POWER:PPEak?](#) on page 1115
- [POWER:SWITChing:RESult:POWER:RMS?](#) on page 1115
- [POWER:SWITChing:RESult:POWER:STDDev?](#) on page 1115
- [POWER:SWITChing:RESult:POWER:WFMCount?](#) on page 1115
- [POWER:SWITChing:REPort:ADD](#) on page 1113

18.11.2 Configuring Switching Loss

For details of the configuration settings, see [chapter 18.11.3, "Switching Loss Settings"](#), on page 613.

1. Select "Analysis" > "Power".
2. Under "Power Path", select "Switching Loss".
3. Connect the differential voltage probe and the current probe to the oscilloscope.
4. Deskew the probes as described in [chapter 18.1.1.1, "Auto Deskew"](#), on page 563.
5. Connect the probes to the DUT as shown in the "Channels" tab:

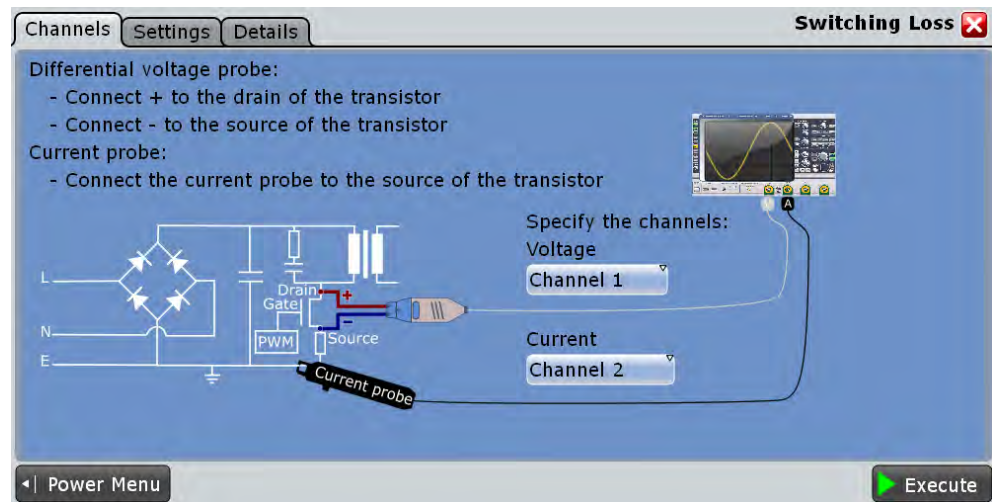

6. Select the correct channels for the "Current Source" and the "Voltage Source".
7. Select the "Settings" tab.
8. Enable the parameters you want to measure.
9. Select an "Optimize Scaling" option.
10. Tap "Execute".

On the screen you can see the measurement waveforms of the current, the voltage and the power. Additionally, the result box with numeric measurement results is shown. For details, see [chapter 18.11.1, "Switching Loss Results"](#), on page 610.

18.11.3 Switching Loss Settings

In the "Channels" tab, you set the current source and the voltage source, see also: [chapter 18.2.1, "Channels Tab"](#), on page 573.

In the "Settings" tab you configure the switching loss parameters and display settings.

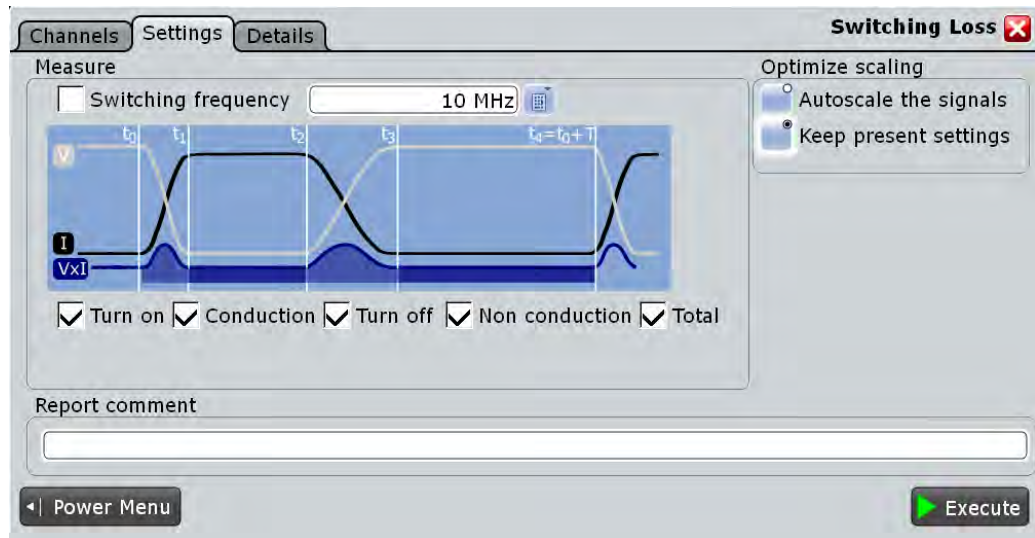

Measure

In this area you can select the parameters that are included in the analysis after executing the measurement.

Switching frequency ← Measure

Enables the measurements of the switching frequency. If disabled you can enter the value of the switching frequency.

Remote command:

[POWER:SWITching:SWIFrequency](#) on page 1113

[POWER:SWITching:SWIT](#) on page 1113

Turn on

Enables the measurements during the turn on period.

Remote command:

[POWER:SWITching:TON](#) on page 1114

Conduction

Enables the measurements during the conduction period.

Remote command:

[POWER:SWITching:COND](#) on page 1114

Turn off

Enables the measurements during the turn off period.

Remote command:

[POWER:SWITching:TOFF](#) on page 1114

Non conduction

Enables the measurements during the non conduction period.

Remote command:

[POWER:SWITching:NCON](#) on page 1114

Total

Enables the measurements of the total period

Remote command:

[POWER:SWITChing:TOTal](#) on page 1114

Optimize scaling

Selects the scaling for the display of the results.

"Autoscale the signals"

Automatically selects the most appropriate scale for the display of the results.

"Keep present settings"

The present display settings are not changed.

Remote command:

[POWER:SWITChing:AUTO](#) on page 1113

Report comment

In this field you can write a comment that will be displayed in the measurement report, for example, a measurement description.

Execute

Starts the "Switching Loss" measurement.

Remote command:

[POWER:SWITChing:EXECute](#) on page 1113

18.12 Power Efficiency

This measurement requires one of the following 4-channel instrument models:
R&S RTO1004, R&S RTO1014, R&S RTO1024, R&S RTO1044.

"Power Efficiency" analysis measures the input and the output power of a power supply. The power efficiency of the power supply is then calculated as the ratio of the output power and the input power.

Required probes:

- Two differential voltage probes
- Two current probes

18.12.1 Power Efficiency Results

The results of "Power Efficiency" measurements are provided in two ways:

- The diagram shows the graphical presentation of:
 - the voltage input waveform
 - the current input waveform
 - the voltage output waveform
 - the voltage input waveform

- the power input waveform
- the power output waveform
- The result box displays the numeric measurement results of the "Input power", "Output power" and the "Efficiency". For a detailed description, see [table 18-2](#).

Result	Current	+Peak	-Peak	μ (Avg)	RMS	σ (S-dev)	Event count	Wave count
Input Power	-570.37 μW	-559.03 μW	-577.39 μW	-569.16 μW	569.17 μW	3.0434 μW	745	1153
Output Power	8.9271 mW	8.9377 mW	8.9145 mW	8.9262 mW	8.9262 mW	3.5203 μW	745	1153
Efficiency	-1565.2 %	-1548.5 %	-1593.5 %	-1568.7 %	1568.7 %	8.0868 %	745	1153

To measure and display the power quality, the instrument uses the following measurements and waveforms:

- "P7" Meas 7 to measure the input power waveform
- "P8" Meas 8 to measure the output power waveform
- "M2" Math 2 to calculate the input power
- "M3" Math 3 to calculate the output power

The used resources are listed in the "Details" tab. See also: [chapter 18.2.3, "Details Tab"](#), on page 575.

"Power Efficiency" is a statistical evaluation that will be reset only if the measurement setup is changed or you reset the statistics.

The following remote commands are used for handling the measurement results:

- `POWER:EFFiciency:RESult<m>:ACTual?` on page 1116
- `POWER:EFFiciency:RESult<m>:AVG?` on page 1116
- `POWER:EFFiciency:RESult<m>:EVTCount?` on page 1116
- `POWER:EFFiciency:RESult<m>:NPEak?` on page 1116
- `POWER:EFFiciency:RESult<m>:PPEak?` on page 1116
- `POWER:EFFiciency:RESult<m>:RMS?` on page 1116
- `POWER:EFFiciency:RESult<m>:STDDev?` on page 1116
- `POWER:EFFiciency:RESult<m>:WFMCount?` on page 1116
- `POWER:EFFiciency:REPort:ADD` on page 1116

18.12.2 Configuring Power Efficiency

For details of the configuration settings, see [chapter 18.12.3, "Power Efficiency Settings"](#), on page 617.

1. Select "Analysis" > "Power".
2. Under "Power Path", select "Power Efficiency".
3. Connect the differential voltage probes and the current probes to the oscilloscope.
4. Deskew the probes as described in [chapter 18.1.1.1, "Auto Deskew"](#), on page 563.

5. Connect the probes to the DUT as shown in the graphic of the "Channels" tab:

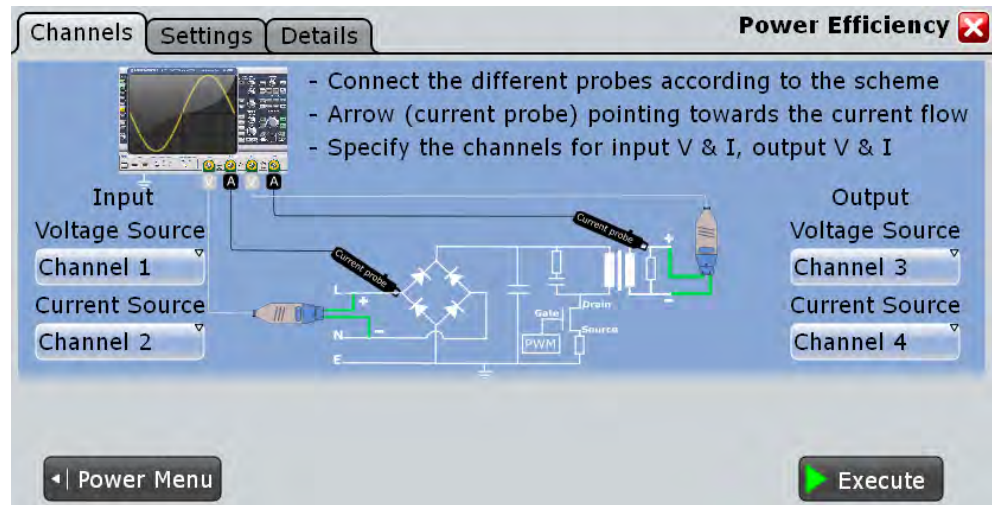

6. Select the correct channels for the "Current Source" and the "Voltage Source" of the input and the output.
7. Select the "Settings" tab.
8. Select an "Optimize Scaling" option.
9. Tap "Execute".

On the screen you can see the measurement waveforms of the input power and the output power. Additionally, the result box with numeric measurement results is shown. For details, see [chapter 18.12.1, "Power Efficiency Results"](#), on page 615

18.12.3 Power Efficiency Settings

In the "Channels" tab, you set the current source and the voltage source, see also: [chapter 18.2.1, "Channels Tab"](#), on page 573.

In the "Settings" tab you configure the power efficiency display settings.

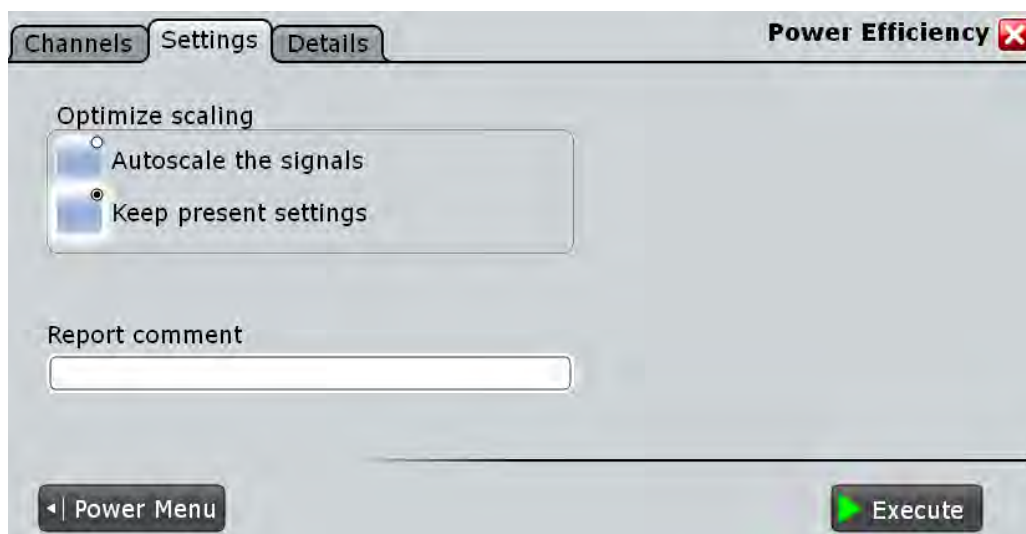
**Optimize scaling**

Selects the scaling for the display of the results.

"Autoscale the signals"

Automatically selects the most appropriate scale for the display of the results.

"Keep present settings"

The present display settings are not changed.

Remote command:

[POWER:EFFiciency:AUTO](#) on page 1115

Report comment

In this field you can write a comment that will be displayed in the measurement report, for example, a measurement description.

Execute

Starts the "Power Efficiency" measurement.

Remote command:

[POWER:EFFiciency:EXECute](#) on page 1116

18.13 Output Ripple

The "Output Ripple" analysis measures the ripple of the device output. You can measure the voltage ripple alone or the voltage and the current ripple simultaneously. In this measurement the peak-to-peak extremes of the output DC signal are of interest. The measurement also includes the AC-RMS of the output DC signal, that is calculated as a standard derivation.

Required probes:

- Voltage probe

- (Optional) Current probe

18.13.1 Output Ripple Results

The results of "Output Ripple" measurements are provided in two ways:

- The diagram shows the graphical presentation of:
 - the voltage waveform
 - (optional) the current waveform
- The result box displays the numeric measurement results for the voltage and for the current ripple. For details, see [table 18-5](#).

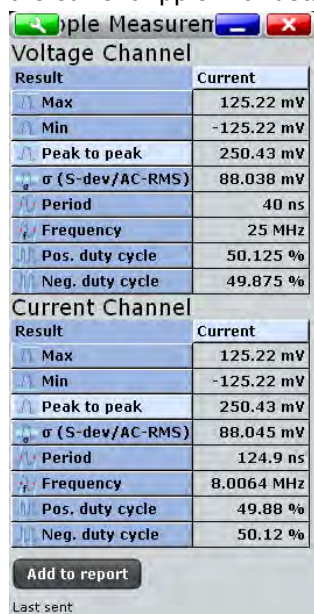





To measure and display the output ripple, the instrument uses the following measurements and waveforms:

- "P7" Meas 7 to measure the current
- "P8" Meas 8 to measure the voltage

The used resources are listed in the "Details" tab. See also: [chapter 18.2.3, "Details Tab"](#), on page 575.

Table 18-5: Properties output ripple

	Meas. type	Symbol	Description/Result
	Max	X_{Max}	Absolute maximum value of the waveform.
	Min	X_{Min}	Absolute minimum value of the waveform.
	Peak to peak	X_{PkPk}	Peak-to-peak value of the waveform: the difference of maximum and minimum values. $X_{Ampl} = X_{Max} - X_{Min}$

	Meas. type	Symbol	Description/Result
	σ (S-dev/AC-RMS)	σ_X	Standard deviation of the waveform samples
	Period	T_{Period}	Time of the left-most signal period of the waveform - the time difference between two consecutive waveform edges measured on the middle reference level. The measurement requires at least one complete period of a triggered signal. Multiple measurement is possible.
	Frequency	f_{Period}	Frequency of the signal, reciprocal value of the period. $f_{Period} = 1 / T_{Period}$
	Pos. duty cycle	R_{PosCyc}	Positive duty cycle: Width of a positive pulse in relation to the period in %. The measurement requires at least one complete period of a triggered signal. Multiple measurement is possible. $R_{PosCyc} = \frac{T_{PosPulse}}{T_{Period}} \cdot 100\%$
	Neg. duty cycle	R_{NegCyc}	Negative duty cycle: Width of a negative pulse in relation to the period in %. The measurement requires at least one complete period of a triggered signal. Multiple measurement is possible. $R_{NegCyc} = \frac{T_{NegPulse}}{T_{Period}} \cdot 100\%$

The following remote commands are used for handling the measurement results:

- [POWER:RIPPLE:RESult:FREQuency?](#) on page 1117
- [POWER:RIPPLE:RESult:MAXimum?](#) on page 1117
- [POWER:RIPPLE:RESult:MINimum?](#) on page 1117
- [POWER:RIPPLE:RESult:NDCYcle?](#) on page 1117
- [POWER:RIPPLE:RESult:PDCYcle?](#) on page 1118
- [POWER:RIPPLE:RESult:PDEL?](#) on page 1118
- [POWER:RIPPLE:RESult:PERiod?](#) on page 1118
- [POWER:RIPPLE:RESult:STDDev?](#) on page 1118
- [POWER:RIPPLE:REPort:ADD](#) on page 1117

18.13.2 Configuring Output Ripple

For details of the configuration settings, see [chapter 18.13.3, "Output Ripple Settings"](#), on page 621.

1. Select "Analysis" > "Power".
2. Under "Output", select "Ripple".
3. Connect the voltage probe to the oscilloscope.

4. If you want to measure the current ripple enable the current channel and connect the current probe to the oscilloscope.
5. If you want to measure both the voltage and the current ripple deskew the probes as described in [chapter 18.1.1.1, "Auto Deskew"](#), on page 563.
6. Connect the probes to the DUT as shown in the "Channels" tab:

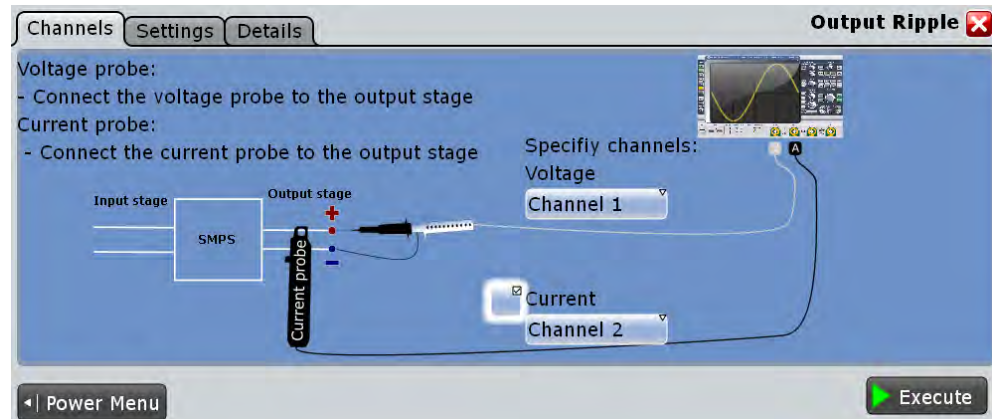

7. Select the correct channels for the "Voltage Source" and the "Current Source".
8. Select the "Settings" tab.
9. Set the "SMPS switching frequency" according to your signal.
10. Select an "Optimize Scaling" option.
11. Tap "Execute".

On the screen you can see the measurement waveforms of the current and the voltage. Additionally, the result box with numeric measurement results is shown. For details, see [chapter 18.13.1, "Output Ripple Results"](#), on page 619.

18.13.3 Output Ripple Settings

In the "Channels" tab, you set the current source and the voltage source, see also: [chapter 18.2.1, "Channels Tab"](#), on page 573 and `POWer:RIPPlE:CURRent` on page 1117)

In the "Settings" tab you configure the ripple parameters and display settings.

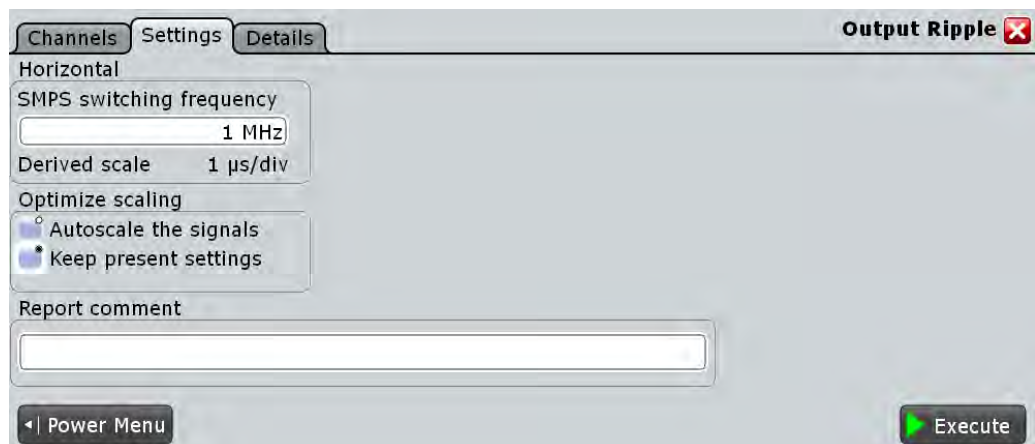

Horizontal

Configures the horizontal scale of the result diagram.

SMPS switching frequency ← Horizontal

Sets the SMPS switching frequency. Set the value according to your DUT.

Remote command:

[POWER:RIPPLE:FREQUENCY](#) on page 1117

Derived scale ← Horizontal

Shows the scale of the the displayed results. This value is calculated as the inverse of the "SMPS switching frequency"

Optimize scaling

Selects the scaling for the display of the results.

"Autoscale the signals"

Automatically selects the most appropriate scale for the display of the results.

"Keep present settings"

The present display settings are not changed.

Remote command:

[POWER:RIPPLE:AUTOSCALE](#) on page 1117

Report comment

In this field you can write a comment that will be displayed in the measurement report, for example, a measurement description.

Execute

Starts the "Output Ripple" measurement.

Remote command:

[POWER:RIPPLE:EXECUTE](#) on page 1117

18.14 Transient Response

The "Transient Response" analysis measures the response of a system to a change from equilibrium. This response is described by different properties like the rise time, the overshoot, the settling time, the peak time and the delay time.

Required probes:

- One or two voltage probes
- Current probe

18.14.1 Transient Response Results

The results of "Power Quality" measurements are provided in two ways:

- The diagram shows the graphical presentation of:
 - the voltage waveform(s)
 - the current waveform
- The result box displays the numeric measurement results.



To measure and display the transient response, the instrument uses the following measurements and waveforms:

- "P8" Meas 8 to measure the rise time and the overshoot
- "C2" Cursor 2 to measure the settling time
- "C3" Cursor 3 to measure the peak time
- "C4" Cursor 4 to calculate the delay time

The used resources are listed in the "Details" tab. See also: [chapter 18.2.3, "Details Tab"](#), on page 575.

The results describing the transient response of the system are shown in [figure 18-5](#) and described in [table 18-6](#).

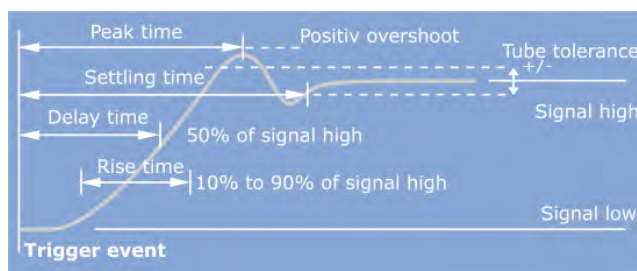

Fig. 18-5: Graphical presentation of the transient response properties

Table 18-6: Transient response

Result	Description
Rise time	The time needed for the signal to change from 10% to 90% of the specified signal high.
Overshoot level	The maximum swing level above the signal high.
Settling time	The time elapsed from the trigger event to the time the output enters and remains within the tube tolerance band.
Peak time	The time needed for the response to reach the first peak of the overshoot.
Delay time	The time needed for the response to reach half of the signal high value, after the trigger event.

The following remote commands are used for handling the measurement results:

- `POWer:TRANSient:RESult[:ACTual]?` on page 1119
- `POWer:TRANSient:REPort:ADD` on page 1119

18.14.2 Configuring Transient Response

For details of the configuration settings, see [chapter 18.14.3, "Transient Response Settings"](#), on page 625.

1. Select "Analysis" > "Power".
2. Under "Output", select "Transient Response".
3. Connect the voltage probe(s) and the current probe to the oscilloscope.
4. Deskew the probes as described in [chapter 18.1.1.1, "Auto Deskew"](#), on page 563.
5. Connect the probes to the DUT as shown in the "Channels" tab:

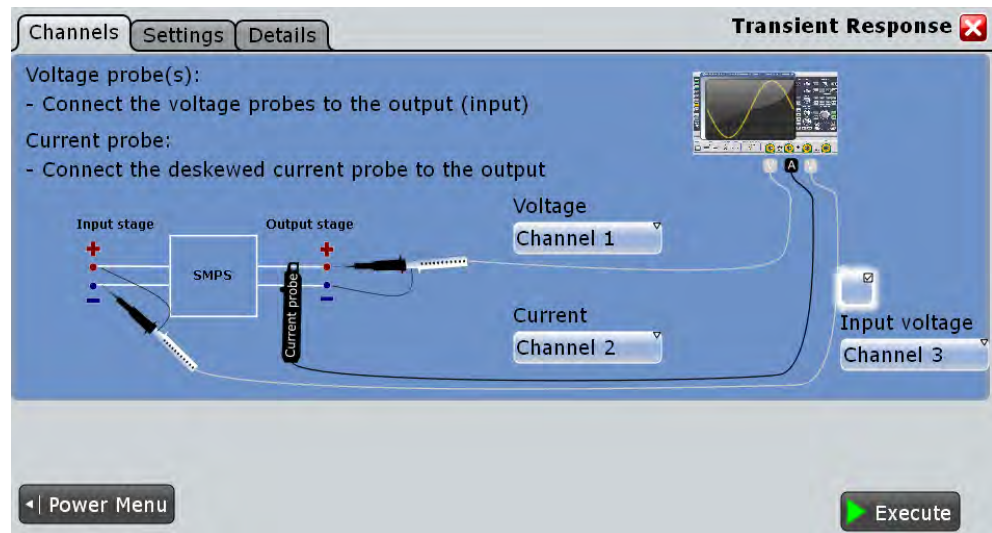

6. Select the correct channels for the "Current Source" and the "Voltage Source".
7. Select the "Settings" tab.
8. Set the "Trigger" settings according to your signal.
9. Set the "Tube tolerance", "Signal high" and "Signal low" according to your requirements.
10. Set the "SMPS switching frequency" according to your device.
11. Select an "Optimize Scaling" option.
12. Tap "Execute".
13. If needed adjust the cursors manually. You can tap on a cursor and change its position with the NAVIGATION ROTARY KNOB.

On the screen you can see the measurement of the current and the voltage . Additionally there is a table giving information about important measurement parameters. For details, see [chapter 18.14.1, "Transient Response Results"](#), on page 623.

18.14.3 Transient Response Settings

In the "Channels" tab, you set the current source and the voltage sources, see also: [chapter 18.2.1, "Channels Tab"](#), on page 573 and `POWer:TRANsient:INPut` on page 1119.

In the "Settings" tab you configure the transient response measurement parameters and display settings.

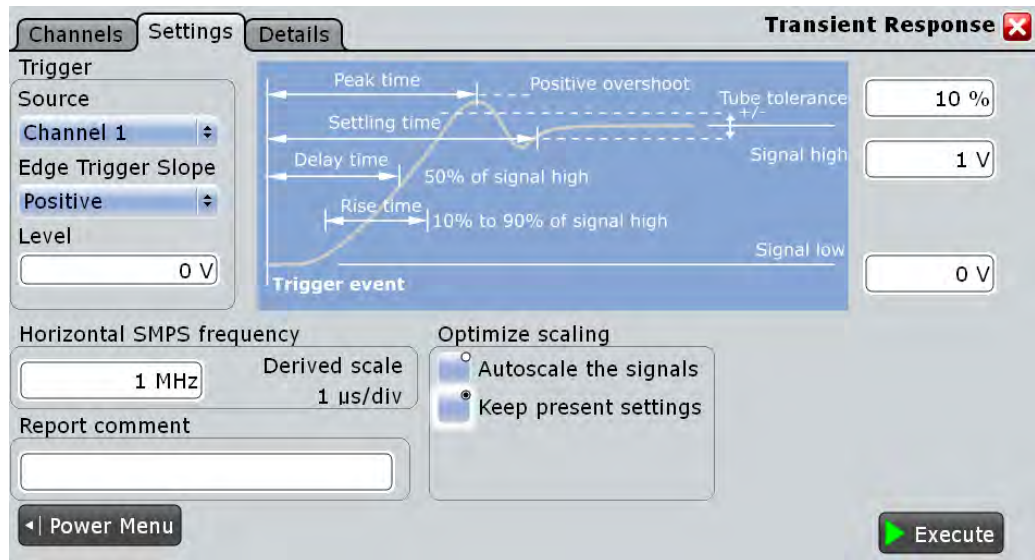
**Trigger**

Sets the properties of the trigger.

Source ← Trigger

Sets the source channel of the trigger.

Remote command:

[POWER:TRANSient:TRGChannel](#) on page 1120

Edge Trigger Slope ← Trigger

Sets the edge type for the trigger event.

"Positive" Selects the rising edge, that is a positive voltage change.

"Negative" Selects the falling edge, that is a negative voltage change.

"Both" Selects the rising as well as the falling edge.

Remote command:

[POWER:TRANSient:TRGSlope](#) on page 1120

Level ← Trigger

Sets the voltage or current level for the trigger event.

Remote command:

[POWER:TRANSient:TRGLevel](#) on page 1120

Tube tolerance

Specifies a tolerated error band for the signal level.

Remote command:

[POWER:TRANSient:HYSTeresis](#) on page 1119

Signal high

Sets the expected signal high voltage value.

Remote command:

[POWer:TRANsient:SIGHigh](#) on page 1120

Signal low

Sets the expected signal low voltage value.

Remote command:

[POWer:TRANsient:SIGLow](#) on page 1120

Horizontal

Configures the horizontal scale of the result diagram.

SMPS switching frequency ← Horizontal

Sets the SMPS switching frequency. Set the value according to your DUT.

Remote command:

[POWer:TRANsient:FREQuency](#) on page 1119

Derived scale ← Horizontal

Shows the scale of the the displayed results. This value is calculated as the inverse of the "SMPS switching frequency"

Optimize scaling

Selects the scaling for the display of the results.

"Autoscale the signals"

Automatically selects the most appropriate scale for the display of the results.

"Keep present settings"

The present display settings are not changed.

Remote command:

[POWer:TRANsient:AUToscale](#) on page 1118

Report comment

In this field you can write a comment that will be displayed in the measurement report, for example, a measurement description.

Execute

Starts the "Transient Response" measurement.

Remote command:

[POWer:TRANsient:EXECute](#) on page 1119

18.15 Output Spectrum

"Output Spectrum" analysis measures the spectrum of the output voltage. The results can be applied to see typical side effect problems of the SMPS application, such as switching frequency components of internal SMPS.

Required probes:

- Voltage probe

18.15.1 Output Spectrum Results

After executing the "Output Spectrum" measurement the following windows are displayed:

The results of "Power Quality" measurements are provided in two ways:

- Two diagrams that shows the graphical presentation of:
 - the voltage waveform
 - the spectrum
- The result box displays the positions of the measured peaks.

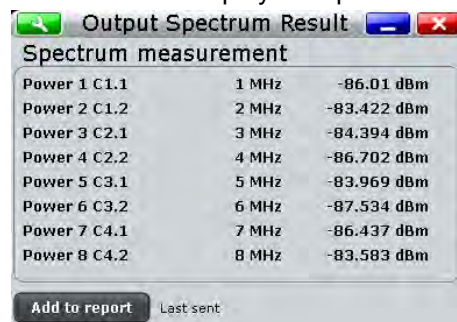

Spectrum measurement		
Power 1 C1.1	1 MHz	-86.01 dBm
Power 2 C1.2	2 MHz	-83.422 dBm
Power 3 C2.1	3 MHz	-84.394 dBm
Power 4 C2.2	4 MHz	-86.702 dBm
Power 5 C3.1	5 MHz	-83.969 dBm
Power 6 C3.2	6 MHz	-87.534 dBm
Power 7 C4.1	7 MHz	-86.437 dBm
Power 8 C4.2	8 MHz	-83.583 dBm

Buttons: Add to report, Last sent

To measure and display the output spectrum, the instrument uses the following measurements and waveforms:

- "M4" Math 4 to calculate the magnitude of the FFT for the voltage source values
- "C1" to "C4": Cursor 1 to Cursor 4 to determine the positions of the peaks

The used resources are listed in the "Details" tab. See also: [chapter 18.2.3, "Details Tab"](#), on page 575.

The measured peaks have different origin. Analyzing the frequencies gives information about the influences on the output signal.

The following remote commands are used for handling the measurement results:

- `POWer:SPECTrum:RESult<m>:FREQuency?` on page 1121
- `POWer:SPECTrum:RESult<m>:LEVel?` on page 1122
- `POWer:SPECTrum:REPort:ADD` on page 1121

18.15.2 Configuring Output Spectrum

For details of the configuration settings, see [chapter 18.15.3, "Output Spectrum Settings"](#), on page 629.

1. Select "Analysis">"Power".
2. Under "Output", select "Spectrum".
3. Select the "Channels" tab.
4. Connect the probe to the DUT and to the oscilloscope as shown in the graphic:

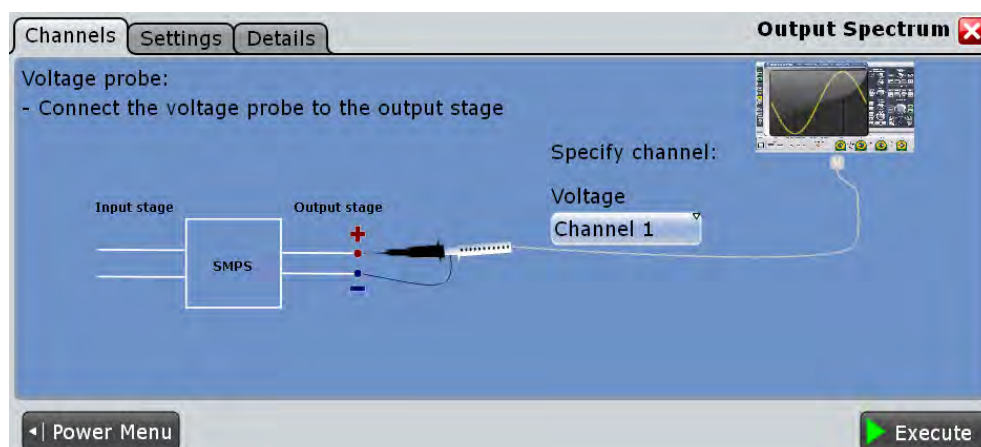

5. Select the correct channel for the "Voltage Source".
6. Select the "Settings" tab.
7. Set the "SMPS switching frequency" according to your signal.
8. Select an "Optimize Scaling" option.
9. Tap "Execute".
10. Set the positions of the cursors according to the measured spectrum. You can tap on a cursor and change its position with the NAVIGATION ROTARY KNOB.

On the screen you can see the measurement of the spectrum. Additionally, the result box shows the position of the peaks. For details, see [chapter 18.15.1, "Output Spectrum Results"](#), on page 628.

18.15.3 Output Spectrum Settings

In the "Channels" tab, you set the voltage source, see also: [chapter 18.2.1, "Channels Tab"](#), on page 573.

In the "Settings" tab you configure the spectrum measurement parameters and display settings.

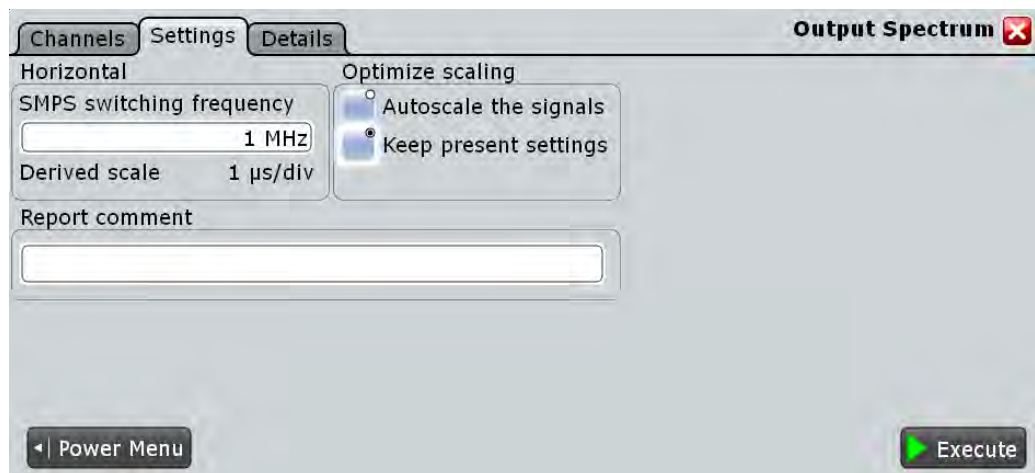
**Horizontal**

Configures the horizontal scale of the result diagram.

SMPS switching frequency ← Horizontal

Sets the SMPS switching frequency. Set the value according to your DUT.

Remote command:

[POWer:SPECTrum:FREQuency](#) on page 1121

Derived scale ← Horizontal

Shows the scale of the the displayed results. This value is calculated as the inverse of the "SMPS switching frequency"

Optimize scaling

Selects the scaling for the display of the results.

"Autoscale the signals"

Automatically selects the most appropriate scale for the display of the results.

"Keep present settings"

The present display settings are not changed.

Remote command:

[POWer:SPECTrum:AUToscale](#) on page 1121

Report comment

In this field you can write a comment that will be displayed in the measurement report, for example, a measurement description.

Execute

Starts the "Output Spectrum" measurement.

Remote command:

[POWer:SPECTrum:EXECute](#) on page 1121

19 USB 2.0 Compliance Test (Option R&S RTO-K21)

The R&S RTO-K21 option enables the automatic testing of USB 2.0 compliance (high-speed) as well as USB 1.1 (full-speed) and USB 1.0 (low-speed).

In addition to the R&S RTO-K21 option, USB 2.0 compliance testing requires the following Rohde & Schwarz components:

- R&S RT-ZF1 USB 2.0 compliance test fixture set, comprising two test boards – the load board and the signal quality board.
- R&S ScopeSuite software. The software guides you step-by-step through the test sequences, configures the oscilloscope, automatically performs measurements and compiles the results in a measurement report.

Note the following requirements:

- The R&S RTO-K21 option requires a 4-channel instrument model with at least 2 GHz bandwidth: R&S RTO1024 or R&S RTO1044. For R&S RTO1014 or R&S RTO1004, a bandwidth extension 2 GHz or 4 GHz (R&S RTO-B201 to 205) is required.
- The free-of-charge R&S ScopeSuite software requires the Windows 7 operating system. It can be installed on a computer or directly on the R&S RTO if the instrument has Windows 7.
- Make sure that you use the latest version of the USBHSET tool. Check the following websites for downloads:
 - USB 3.0 host: www.usb.org/developers/tools/
 - USB 2.0 host: www.usb.org/developers/tools/usb20_tools/

Regularly check the USB-IF website compliance.usb.org/index.asp?Update-File=Electrical&Format=Standard for USB-IF compliance updates.

As an example, the test setup for USB device tests is shown below.

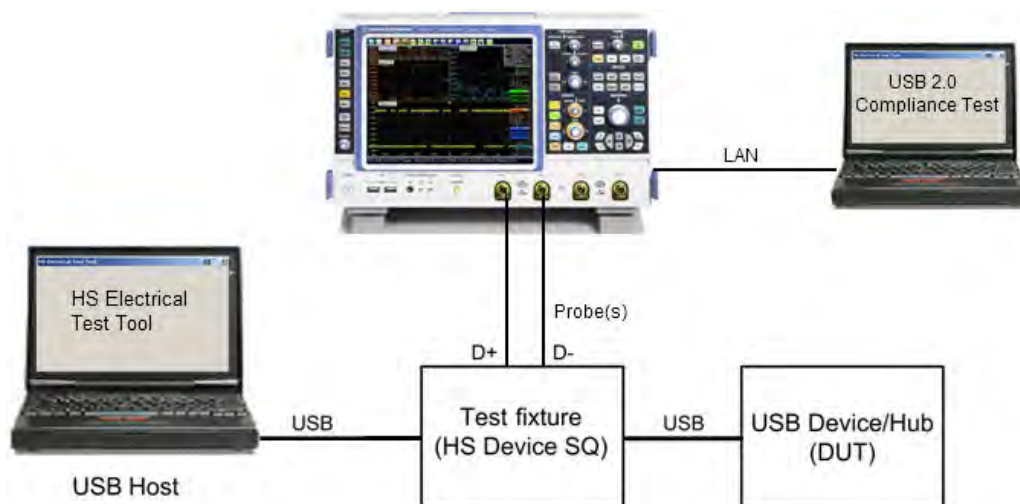

The test fixture and the USB compliance test procedures are described in separate manuals:

- "R&S®RTO-K21 USB 2.0 Compliance Test, Test Procedures"
- "R&S®RT-ZF1 USB 2.0 Compliance Test Fixture Set, Manual"

20 Ethernet Compliance Test (Option R&S RTO-K22)

The R&S RTO-K22 option enables the automatic testing of Ethernet standards 10BASE-T, 100BASE-TX, 1000BASE-T, 10GBASE-T.

In addition to the R&S RTO-K22 option, Ethernet compliance testing requires the following Rohde & Schwarz components:

- R&S RT-ZF2 Ethernet compliance test fixture set, comprising two test boards – the load board and the signal quality board.
- R&S ScopeSuite software. The software guides you step-by-step through the test sequences, configures the oscilloscope, automatically performs measurements and compiles the results in a measurement report.

Note the following requirements:

- Ethernet compliance tests 10/100/1000BASE-T require an oscilloscope with at least 600 MHz bandwidth: R&S RTO1002, or R&S RTO1004, or higher; and probes with at least 1 GHz bandwidth: R&S RT-ZD10 or higher.
- The free-of-charge R&S ScopeSuite software requires the Windows 7 64 bit operating system. It can be installed on a computer or directly on the R&S RTO if the instrument has Windows 7.

The test fixture and the Ethernet compliance test procedures are described in the separate manuals:

- "R&S®RTO-K22 Ethernet Compliance Test, Test Procedures"
- "R&S®RT-ZF2 Ethernet Compliance Test Fixture Set, Manual"

21 Remote Control

21.1 Basics

This chapter provides basic information on operating an instrument via remote control.

21.1.1 Remote Control Interfaces and Protocols

The instrument supports different interfaces for remote control. The following table gives an overview.

Table 21-1: Remote control interfaces and protocols

Interface	Protocols, VISA address string	Remarks
Local Area Network (LAN)	Protocol: VXI-11 VISA address string: TCPIP:: <ip address="">::inst0::INSTR</ip>	The LAN connector is located on rear panel of the instrument. The interface is based on TCP/IP and supports the VXI-11 protocol. See also: <ul style="list-style-type: none"> • "VXI-11 Protocol" on page 636 • chapter 21.1.1.1, "VISA Libraries", on page 634
GPIB (IEC/IEEE Bus Interface)	VISA address string: GPIB::primary address[:INSTR] (no secondary address)	The optional GPIB bus interface according to standard IEC 625.1/IEEE 488.1 is located on the rear panel of the instrument. See also: chapter 21.1.1.3, "GPIB Interface (IEC/IEEE Bus Interface)" , on page 636.



Within this interface description, the term GPIB is used as a synonym for the IEC/IEEE bus interface.

SCPI (Standard Commands for Programmable Instruments)

SCPI commands - messages - are used for remote control. Commands that are not taken from the SCPI standard follow the SCPI syntax rules. The instrument supports the SCPI version 1999. The SCPI standard is based on standard IEEE 488.2 and aims at the standardization of device-specific commands, error handling and the status registers. The tutorial "Automatic Measurement Control - A tutorial on SCPI and IEEE 488.2" from John M. Pieper (R&S order number 0002.3536.00) offers detailed information on concepts and definitions of SCPI.

21.1.1.1 VISA Libraries

VISA is a standardized software interface library providing input and output functions to communicate with instruments. Instrument access via VXI11 protocol is usually achieved from high level programming platforms using VISA as an intermediate abstrac-

tion layer. VISA encapsulates the low level VXI or even GPIB function calls and thus makes the transport interface transparent for the user.

The I/O channel (LAN or TCP/IP, USB, GPIB,...) is selected at initialization time by means of the channel-specific address string ("VISA resource string") indicated in [table 21-1](#), or by an appropriately defined VISA alias (short name). A VISA installation is a prerequisite for remote control of R&S RTO.

For more information about VISA refer to the VISA user documentation.

21.1.1.2 LAN Interface

To be integrated in a LAN, the instrument is equipped with a LAN interface, consisting of a connector, a network interface card and protocols. For remote control via a network, the PC and the instrument must be connected via the LAN interface to a common network with TCP/IP network protocol. They are connected using a commercial RJ45 cable. The TCP/IP network protocol and the associated network services are pre-configured on the instrument. Software for instrument control and the VISA program library for specified protocols must be installed on the controller.

IP address

Only the IP address of the instrument is required to set up the connection. It is part of the "VISA resource string" used by programs to identify and control the instrument. The VISA resource string has the form:

```
TCPIP::::inst0::INSTR
```

where:

- `IP address` identifies the instrument in the network
- `inst0` is the LAN device name. VISA supports several devices running on the instrument. On R&S RTO, only one device is configured, so the LAN device name can be omitted.
- `INSTR` indicates that the VXI-11 protocol is used

Example: If the instrument has the IP address *192.1.2.3*, the valid resource string is:

```
TCPIP::192.1.2.3::INSTR
```

If the LAN is supported by a DNS server, the host name can be used instead of the IP address. The DNS server (Domain Name System server) translates the host name to the IP address. The VISA resource string has the form:

```
TCPIP::::inst0::INSTR
```

Example: If the computer name is *RSRT1*, the valid resource string is:

```
TCPIP::RSRT1::INSTR.
```

See also:

- Find IP address: SETUP > "System" tab, see [chapter 12.2.1.1, "System"](#), on page 393
- [chapter 13.4.1.2, "Assigning the IP Address"](#), on page 412

VXI-11 Protocol

The VXI-11 standard is based on the ONC RPC (Open Network Computing Remote Procedure Call) protocol which in turn relies on TCP/IP as the network/transport layer. The TCP/IP network protocol and the associated network services are preconfigured. TCP/IP ensures connection-oriented communication, where the order of the exchanged messages is adhered to and interrupted links are identified. With this protocol, messages cannot be lost.

21.1.1.3 GPIB Interface (IEC/IEEE Bus Interface)

To be able to control the instrument via the GPIB bus, the instrument and the controller must be linked by a GPIB bus cable. A GPIB bus card, the card drivers and the program libraries for the programming language used must be provided in the controller. The controller must address the instrument with the GPIB bus address.

Characteristics

- Up to 15 instruments can be connected
- The total cable length is restricted to a maximum of 15 m; the cable length between two instruments should not exceed 2m.
- A wired "OR"-connection is used if several instruments are connected in parallel.

GPIB Instrument Address

In order to operate the instrument via remote control, it must be addressed using the GPIB address. The remote control address is factory-set to 20, but it can be changed in the network environment settings. For remote control, addresses 0 through 30 are allowed. The GPIB address is maintained after a reset of the instrument settings.

See also: "[Address](#)" on page 400.

21.1.2 Starting and Stopping Remote Control

21.1.2.1 Starting a Remote Control Session

When you switch on the instrument, it is always in manual operation state ("local" state) and can be operated via the front panel, the touch screen and external keyboard and/or mouse.

- ▶ To start remote control:
 - Send a command from the controller.
 - VXI-11 protocol (LAN or USB interface): Use `>R` interface message.

While remote control is active, the instrument settings are optimized for maximum measurement speed; the display is switched off. Operation via the front panel is disabled.

On the touch screen, two buttons appear in the upper left corner: "Local" and "View".

21.1.2.2 Using the display during remote control

You can observe the screen while a remote control script is executed. This is helpful for program test purposes but tends to slow down the measurement. Therefore it is recommended that you switch off the display in real measurement applications where a tested program script is to be executed repeatedly.

- ▶ To switch on the display, do one of the following:
 - Tap the "View" button in the upper left corner of the touch screen.
 - Use the `SYSTem:DISPlay:UPDate ON` command.
- ▶ To switch off the display, do one of the following:
 - Tap the "View" button again.
 - Use the `SYSTem:DISPlay:UPDate OFF` command.

21.1.2.3 Returning to Manual Operation

The instrument switches back to manual operation when the remote connection is closed. Besides, you can return to manual operation manually or via remote control.

- ▶ To return to manual operation:
 - Tap the "Local" button in the upper left corner of the touch screen.
 - VXI-11 protocol: Use `>L` interface message.

21.1.3 Messages

21.1.3.1 Instrument Messages

Instrument messages are employed in the same way for all interfaces, if not indicated otherwise in the description.

There are different types of instrument messages, depending on the direction they are sent:

- Commands
- Instrument responses

Commands

Commands (program messages) are messages the controller sends to the instrument. They operate the instrument functions and request information. The commands are subdivided according to two criteria:

- According to the effect they have on the instrument:

- **Setting commands** cause instrument settings such as a reset of the instrument or setting the frequency.
- **Queries** cause data to be provided for remote control, e.g. for identification of the instrument or polling a parameter value. Queries are formed by directly appending a question mark to the command header.
- According to their definition in standards:
 - **Common commands**: their function and syntax are precisely defined in standard IEEE 488.2. They are employed identically on all instruments (if implemented). They refer to functions such as management of the standardized status registers, reset and self test.
 - **Instrument control commands** refer to functions depending on the features of the instrument such as frequency settings. Many of these commands have also been standardized by the SCPI committee. These commands are marked as "SCPI compliant" in the command reference chapters. Commands without this SCPI label are device-specific, however, their syntax follows SCPI rules as permitted by the standard.

Instrument responses

Instrument responses (response messages and service requests) are messages the instrument sends to the controller after a query. They can contain measurement results, instrument settings and information on the instrument status.

See also:

- Structure and syntax of the instrument messages are described in [chapter 21.1.4, "SCPI Command Structure"](#), on page 640.
- Detailed description of all messages: [chapter 21.2, "Command Reference"](#), on page 663

21.1.3.2 Interface Messages

Interface messages are transmitted to the instrument on the data lines. They are used to communicate between the controller and the instrument. Interface messages can only be sent by instruments that have GPIB bus functionality.

GPIB Interface Messages

Interface messages are transmitted to the instrument on the data lines, with the attention line (ATN) being active (LOW). They are used for communication between the controller and the instrument and can only be sent by a computer which has the function of a GPIB bus controller. GPIB interface messages can be further subdivided into:

- **Universal commands**: act on all instruments connected to the GPIB bus without previous addressing
- **Addressed commands**: only act on instruments previously addressed as listeners

Universal Commands

Universal commands are encoded in the range 10 through 1F hex. They affect all instruments connected to the bus and do not require addressing.

Command	Effect on the instrument
DCL (Device Clear)	Aborts the processing of the commands just received and sets the command processing software to a defined initial state. Does not change the instrument settings.
IFC (Interface Clear) *)	Resets the interfaces to the default setting.
LLO (Local Lockout)	The LOC/IEC ADDR key is disabled.
SPE (Serial Poll Enable)	Ready for serial poll.
SPD (Serial Poll Disable)	End of serial poll.
PPU (Parallel Poll Unconfigure)	End of the parallel-poll state.
*) IFC is not a real universal command, it is sent via a separate line; however, it also affects all instruments connected to the bus and does not require addressing	

Addressed Commands

Addressed commands are encoded in the range 00 through 0F hex. They only affect instruments addressed as listeners.

Command	Effect on the instrument
GET (Group Execute Trigger)	Triggers a previously active instrument function (e.g. a sweep). The effect of the command is the same as with that of a pulse at the external trigger signal input.
GTL (Go to Local)	Transition to the "local" state (manual control).
GTR (Go to Remote)	Transition to the "remote" state (remote control).
PPC (Parallel Poll Configure)	Configures the instrument for parallel poll.
SDC (Selected Device Clear)	Aborts the processing of the commands just received and sets the command processing software to a defined initial state. Does not change the instrument setting.

LAN Interface Messages

In the LAN connection, the interface messages are called low-level control messages. These messages can be used to emulate interface messages of the GPIB bus.

Command	Long term	Effect on the instrument
&ABO	Abort	Aborts processing of the commands just received.
&DCL	Device Clear	Aborts processing of the commands just received and sets the command processing software to a defined initial state. Does not change the instrument setting.
>L	Go to Local	Transition to the "local" state (manual control). (The instrument automatically returns to remote state when a remote command is sent UNLESS &NREN was sent before.)
>R	Go to Remote	Enables automatic transition from local state to remote state by a subsequent remote command (after &NREN was sent).

Command	Long term	Effect on the instrument
&GET	Group Execute Trigger	Triggers a previously active instrument function (e.g. a sweep). The effect of the command is the same as with that of a pulse at the external trigger signal input.
&LLO	Local Lockout	Disables transition from remote control to manual control by means of the front panel keys.
&NREN	Not Remote Enable	Disables automatic transition from local state to remote state by a subsequent remote command. (To re-activate automatic transition use >R.)
&POL	Serial Poll	Starts a serial poll.

21.1.4 SCPI Command Structure

SCPI commands consist of a so-called header and, in most cases, one or more parameters. The header and the parameters are separated by a "white space" (ASCII code 0 to 9, 11 to 32 decimal, e.g. blank). The headers may consist of several mnemonics (keywords). Queries are formed by appending a question mark directly to the header.

The commands can be either device-specific or device-independent (common commands). Common and device-specific commands differ in their syntax.

21.1.4.1 Syntax for Common Commands

Common (=device-independent) commands consist of a header preceded by an asterisk (*) and possibly one or more parameters.

Examples:

*RST	RESET	Resets the instrument.
*ESE	EVENT STATUS ENABLE	Sets the bits of the event status enable registers.
*ESR?	EVENT STATUS QUERY	Queries the contents of the event status register.
*IDN?	IDENTIFICATION QUERY	Queries the instrument identification string.

21.1.4.2 Syntax for Device-Specific Commands



Not all commands used in the following examples are necessarily implemented in the instrument.

For demonstration purposes only, assume the existence of the following commands for this section:

- DISPLAY[:WINDow<1...4>]:MAXimize <Boolean>
- FORMat:READings:DATA <type>[,<length>]
- HCOpy:DEvice:COLor <Boolean>
- HCOpy:DEvice:CMAP:COLor:RGB <red>,<green>,<blue>
- HCOpy[:IMMediate]
- HCOpy:ITEM:ALL
- HCOpy:ITEM:LABel <string>
- HCOpy:PAGE:DIMensions:QUADrant [<N>]
- HCOpy:PAGE:ORientation LANDscape | PORTrait
- HCOpy:PAGE:SCALE <numeric value>
- MMEMory:COpy <file_source>,<file_destination>
- SENSE:BANDwidth|BWIDth[:RESolution] <numeric_value>
- SENSE:FREQuency:STOP <numeric value>
- SENSE:LIST:FREQuency <numeric_value>{,<numeric_value>}

Long and short form

The mnemonics feature a long form and a short form. The short form is marked by upper case letters, the long form corresponds to the complete word. Either the short form or the long form can be entered; other abbreviations are not permitted.

Example:

HCOpy:DEvice:COLor ON is equivalent to HCOP:DEV:COL ON.



Case-insensitivity

Upper case and lower case notation only serves to distinguish the two forms in the manual, the instrument itself is case-insensitive.

Numeric suffixes

If a command can be applied to multiple instances of an object, e.g. specific channels or sources, the required instances can be specified by a suffix added to the command. Numeric suffixes are indicated by angular brackets (<1...4>, <n>, <i>) and are replaced by a single value in the command. Entries without a suffix are interpreted as having the suffix 1.

Example:

Definition: `HCOPY:PAGE:DIMensions:QUADrant [<N>]`

Command: `HCOP:PAGE:DIM:QUAD2`

This command refers to the quadrant 2.

**Different numbering in remote control**

For remote control, the suffix may differ from the number of the corresponding selection used in manual operation. SCPI prescribes that suffix counting starts with 1. Suffix 1 is the default state and used when no specific suffix is specified.

Some standards define a fixed numbering, starting with 0. If the numbering differs in manual operation and remote control, it is indicated for the corresponding command.

Optional mnemonics

Some command systems permit certain mnemonics to be inserted into the header or omitted. These mnemonics are marked by square brackets in the description. The instrument must recognize the long command to comply with the SCPI standard. Some commands are considerably shortened by these optional mnemonics.

Example:

Definition: `HCOPY[:IMMEDIATE]`

Command: `HCOP:IMM` is equivalent to `HCOP`

**Optional mnemonics with numeric suffixes**

Do not omit an optional mnemonic if it includes a numeric suffix that is relevant for the effect of the command.

Example:

Definition: `DISPlay[:WINDow<1...4>]:MAXimize <Boolean>`

Command: `DISP:MAX ON` refers to window 1.

In order to refer to a window other than 1, you must include the optional `WINDow` parameter with the suffix for the required window.

`DISP:WIND2:MAX ON` refers to window 2.

Parameters

Parameters must be separated from the header by a "white space". If several parameters are specified in a command, they are separated by a comma (.). For a description of the parameter types, refer to [chapter 21.1.4.3, "SCPI Parameters"](#), on page 643.

Example:

Definition: `HCOPY:DEvice:CMAP:COLor:RGB <red>, <green>, <blue>`

Command: `HCOP:DEV:CMAP:COL:RGB 3, 32, 44`

Special characters

	<p>Parameters</p> <p>A vertical stroke in parameter definitions indicates alternative possibilities in the sense of "or". The effect of the command differs, depending on which parameter is used.</p> <p>Example:</p> <p>Definition:HCOPY:PAGE:ORIENTATION LANDscape PORTRait</p> <p>Command HCOP:PAGE:ORI LAND specifies landscape orientation</p> <p>Command HCOP:PAGE:ORI PORT specifies portrait orientation</p> <p>Mnemonics</p> <p>A selection of mnemonics with an identical effect exists for several commands. These mnemonics are indicated in the same line; they are separated by a vertical stroke. Only one of these mnemonics needs to be included in the header of the command. The effect of the command is independent of which of the mnemonics is used.</p> <p>Example:</p> <p>DefinitionSENSE:BANDwidth BWIDTH[:RESolution] <numeric_value></p> <p>The two following commands with identical meaning can be created:</p> <p>SENS:BAND:RES 1</p> <p>SENS:BWID:RES 1</p>
[]	<p>Mnemonics in square brackets are optional and may be inserted into the header or omitted.</p> <p>Example: HCOPY[:IMMEDIATE]</p> <p>HCOP:IMM is equivalent to HCOP</p>
{ }	<p>Parameters in curly brackets are optional and can be inserted once or several times, or omitted.</p> <p>Example: SENSE:LIST:FREQUENCY <numeric_value>{,<numeric_value>}</p> <p>The following are valid commands:</p> <p>SENS:LIST:FREQ 10</p> <p>SENS:LIST:FREQ 10,20</p> <p>SENS:LIST:FREQ 10,20,30,40</p>

21.1.4.3 SCPI Parameters

Many commands are supplemented by a parameter or a list of parameters. The parameters must be separated from the header by a "white space" (ASCII code 0 to 9, 11 to 32 decimal, e.g. blank). Allowed parameters are:

- Numeric values
- Special numeric values
- Boolean parameters
- Text
- Character strings
- Block data

The parameters required for each command and the allowed range of values are specified in the command description.

Numeric values

Numeric values can be entered in any form, i.e. with sign, decimal point and exponent. Values exceeding the resolution of the instrument are rounded up or down. The mantissa may comprise up to 255 characters, the exponent must lie inside the value range -32000 to 32000. The exponent is introduced by an "E" or "e". Entry of the exponent alone is not allowed. In the case of physical quantities, the unit can be entered. Allowed unit prefixes are G (giga), MA (mega), MOHM and MHZ (also allowed), K (kilo), M (milli), U (micro) and N (nano). If the unit is missing, the basic unit is used.

Example: `SENS:FREQ:STOP 1.5GHz = SENS:FREQ:STOP 1.5E9`

Units

For physical quantities, the unit can be entered. Allowed unit prefixes are:

- G (giga)
- MA (mega), MOHM, MHZ
- K (kilo)
- M (milli)
- U (micro)
- N (nano)

If the unit is missing, the basic unit is used.

Example:

`SENSe:FREQ:STOP 1.5GHz = SENSe:FREQ:STOP 1.5E9`

Some settings allow relative values to be stated in percent. According to SCPI, this unit is represented by the `PCT` string.

Example:

`HCOP:PAGE:SCAL 90PCT`

Special numeric values

The texts listed below are interpreted as special numeric values. In the case of a query, the numeric value is provided.

- **MIN/MAX**
MINimum and MAXimum denote the minimum and maximum value.
- **DEF**
DEFault denotes a preset value which has been stored in the EPROM. This value conforms to the default setting, as it is called by the `*RST` command.
- **UP/DOWN**
UP, DOWN increases or reduces the numeric value by one step. The step width can be specified via an allocated step command for each parameter which can be set via UP, DOWN.
- **INF/NINF**

INFinity, Negative INFinity (NINF) represent the numeric values 9.9E37 or -9.9E37, respectively. INF and NINF are only sent as instrument responses.

- **NAN**

Not A Number (NAN) represents the value 9.91E37. NAN is only sent as a instrument response. This value is not defined. Possible causes are the division of zero by zero, the subtraction of infinite from infinite and the representation of missing values.

Example:

Setting command: `SENSe:LIST:FREQ MAXimum`

Query: `SENS:LIST:FREQ?`, Response: `3.5E9`



Queries for special numeric values

The numeric values associated to `MAXimum`/`MINimum`/`DEFault` can be queried by adding the corresponding mnemonics to the command. They must be entered following the quotation mark.

Example: `SENSe:LIST:FREQ? MAXimum`

Returns the maximum numeric value as a result.

Boolean Parameters

Boolean parameters represent two states. The "ON" state (logically true) is represented by "ON" or a numeric value 1. The "OFF" state (logically untrue) is represented by "OFF" or the numeric value 0. The numeric values are provided as the response for a query.

Example:

Setting command: `HCOPY:DEV:COL ON`

Query: `HCOPY:DEV:COL?`

Response: `1`

Text parameters

Text parameters observe the syntactic rules for mnemonics, i.e. they can be entered using a short or long form. Like any parameter, they have to be separated from the header by a white space. In the case of a query, the short form of the text is provided.

Example:

Setting command: `HCOPY:PAGE:ORIENTATION LANDscape`

Query: `HCOP:PAGE:ORI?`

Response: `LAND`

Character strings

Strings must always be entered in quotation marks (' or ").

Example:

```
HCOP:ITEM:LABel "Test1" or HCOP:ITEM:LABel 'Test1'
```

Block data

Block data is a format which is suitable for the transmission of large amounts of data. A command using a block data parameter has the following structure:

Example:

```
FORMat:READings:DATA #45168xxxxxxxx
```

The ASCII character # introduces the data block. The next number indicates how many of the following digits describe the length of the data block. In the example the 4 following digits indicate the length to be 5168 bytes. The data bytes follow. During the transmission of these data bytes all end or other control signs are ignored until all bytes are transmitted.

#0 specifies a data block of indefinite length. The use of the indefinite format requires a `NL^END` message to terminate the data block. This format is useful when the length of the transmission is not known or if speed or other considerations prevent segmentation of the data into blocks of definite length.

21.1.4.4 Overview of Syntax Elements

The following table provides an overview of the syntax elements:

:	The colon separates the mnemonics of a command. In a command line the separating semicolon marks the uppermost command level.
;	The semicolon separates two commands of a command line. It does not alter the path.
,	The comma separates several parameters of a command.
?	The question mark forms a query.
*	The asterisk marks a common command.
'' ''	Quotation marks introduce a string and terminate it (both single and double quotation marks are possible).
#	The hash symbol introduces binary, octal, hexadecimal and block data. <ul style="list-style-type: none"> • Binary: #B10110 • Octal: #O7612 • Hexa: #HF3A7 • Block: #21312
	A "white space" (ASCII-Code 0 to 9, 11 to 32 decimal, e.g. blank) separates the header from the parameters.

21.1.4.5 Structure of a command line

A command line may consist of one or several commands. It is terminated by one of the following:

- a <New Line>
- a <New Line> with EOI
- an EOI together with the last data byte

Several commands in a command line must be separated by a semicolon ";". If the next command belongs to a different command system, the semicolon is followed by a colon.

Example:

```
MMEM: COPY "Test1", "MeasurementXY"; :HCOP: ITEM ALL
```

This command line contains two commands. The first command belongs to the MMEM system, the second command belongs to the HCOP system.

If the successive commands belong to the same system, having one or several levels in common, the command line can be abbreviated. To this end, the second command after the semicolon starts with the level that lies below the common levels. The colon following the semicolon must be omitted in this case.

Example:

```
HCOP: ITEM ALL; :HCOP: IMM
```

This command line contains two commands. Both commands are part of the HCOP command system, i.e. they have one level in common.

When abbreviating the command line, the second command begins with the level below HCOP. The colon after the semicolon is omitted. The abbreviated form of the command line reads as follows:

```
HCOP: ITEM ALL; IMM
```

A new command line always begins with the complete path.

Example:

```
HCOP: ITEM ALL
```

```
HCOP: IMM
```

21.1.4.6 Responses to Queries

A query is defined for each setting command unless explicitly specified otherwise. It is formed by adding a question mark to the associated setting command. According to SCPI, the responses to queries are partly subject to stricter rules than in standard IEEE 488.2.

- The requested parameter is transmitted without a header.
Example: `HCOP: PAGE: ORI?`, **Response:** `LAND`
- Maximum values, minimum values and all other quantities that are requested via a special text parameter are returned as numeric values.
Example: `SENSe: FREQuency: STOP? MAX`, **Response:** `3.5E9`

- Numeric values are output without a unit. Physical quantities are referred to the basic units or to the units set using the `Unit` command. The response `3.5E9` in the previous example stands for 3.5 GHz.
- Truth values (Boolean values) are returned as `0` (for OFF) and `1` (for ON).

Example:

Setting command: `HCOpy:DEV:COL ON`

Query: `HCOpy:DEV:COL?`

Response: `1`

- Text (character data) is returned in a short form.

Example:

Setting command: `HCOpy:PAGE:ORIENTATION LANDscape`

Query: `HCOpy:PAGE:ORI?`

Response: `LAND`

21.1.5 Command Sequence and Synchronization

IEEE 488.2 defines a distinction between overlapped and sequential commands:

- A sequential command is one which finishes executing before the next command starts executing. Commands that are processed quickly are usually implemented as sequential commands.
- An overlapping command is one which does not automatically finish executing before the next command starts executing. Usually, overlapping commands take longer to process and allow the program to do other tasks while being executed. If overlapping commands do have to be executed in a defined order, e.g. in order to avoid wrong measurement results, they must be serviced sequentially. This is called synchronization between the controller and the instrument.

Setting commands within one command line, even though they may be implemented as sequential commands, are not necessarily serviced in the order in which they have been received. In order to make sure that commands are actually carried out in a certain order, each command must be sent in a separate command line.

Example: Commands and queries in one message

The response to a query combined in a program message with commands that affect the queried value is not predictable.

The following commands always return the specified result:

```
:FREQ:STAR 1GHZ;SPAN 100 :FREQ:STAR?
```

Result:

```
1000000000 (1 GHz)
```

Whereas the result for the following commands is not specified by SCPI:

```
:FREQ:STAR 1GHz;STAR?;SPAN 1000000
```

The result could be the value of `START` before the command was sent since the instrument might defer executing the individual commands until a program message terminator is received. The result could also be 1 GHz if the instrument executes commands as they are received.



As a general rule, send commands and queries in different program messages.

Example: Overlapping command with *OPC

The instrument implements `SINGLE` as an overlapped command. Assuming that `SINGLE` takes longer to execute than `*OPC`, sending the following command sequence results in initiating a sweep and, after some time, setting the `OPC` bit in the `ESR`:

```
SINGLE; *OPC.
```

Sending the following commands still initiates a sweep:

```
SINGLE; *OPC; *CLS
```

However, since the operation is still pending when the instrument executes `*CLS`, forcing it into the "Operation Complete Command Idle" State (OCIS), `*OPC` is effectively skipped. The `OPC` bit is not set until the instrument executes another `*OPC` command.

21.1.5.1 Preventing Overlapping Execution

To prevent an overlapping execution of commands, one of the commands `*OPC`, `*OPC?` or `*WAI` can be used. All three commands cause a certain action only to be carried out after the hardware has been set. By suitable programming, the controller can be forced to wait for the corresponding action to occur.

Table 21-2: Synchronization using *OPC, *OPC? and *WAI

Com-mand	Action	Programming the controller
*OPC	Sets the Operation Complete bit in the <code>ESR</code> after all previous commands have been executed.	<ul style="list-style-type: none"> Setting bit 0 in the <code>ESE</code> Setting bit 5 in the <code>SRE</code> Waiting for service request (SRQ)
*OPC?	Stops command processing until 1 is returned. This is only the case after the Operation Complete bit has been set in the <code>ESR</code> . This bit indicates that the previous setting has been completed.	Sending <code>*OPC?</code> directly after the command whose processing should be terminated before other commands can be executed.
*WAI	Stops further command processing until all commands sent before <code>*WAI</code> have been executed.	Sending <code>*WAI</code> directly after the command whose processing should be terminated before other commands are executed.

Command synchronization using `*WAI` or `*OPC?` appended to an overlapped command is a good choice if the overlapped command takes only little time to process. The two synchronization techniques simply block overlapped execution of the command.

For time consuming overlapped commands it is usually desirable to allow the controller or the instrument to do other useful work while waiting for command execution. Use one of the following methods:

*OPC with a service request

1. Set the `OPC` mask bit (bit no. 0) in the `ESE`: `*ESE 1`
2. Set bit no. 5 in the `SRE`: `*SRE 32` to enable `ESB` service request.

3. Send the overlapped command with *OPC
4. Wait for a service request

The service request indicates that the overlapped command has finished.

***OPC? with a service request**

1. Set bit no. 4 in the SRE: *SRE 16 to enable MAV service request.
2. Send the overlapped command with *OPC?
3. Wait for a service request

The service request indicates that the overlapped command has finished.

Event Status Register (ESE)

1. Set the OPC mask bit (bit no. 0) in the ESE: *ESE 1
2. Send the overlapped command without *OPC, *OPC? or *WAI
3. Poll the operation complete state periodically (by means of a timer) using the sequence: *OPC; *ESR?

A return value (LSB) of 1 indicates that the overlapped command has finished.

***OPC? with short timeout**

1. Send the overlapped command without *OPC, *OPC? or *WAI
2. Poll the operation complete state periodically (by means of a timer) using the sequence: <short timeout>; *OPC?
3. A return value (LSB) of 1 indicates that the overlapped command has finished. In case of a timeout, the operation is ongoing.
4. Reset timeout to former value
5. Clear the error queue with `SYStem:ERRor?` to remove the "-410, Query interrupted" entries.

Using several threads in the controller application

As an alternative, provided the programming environment of the controller application supports threads, separate threads can be used for the application GUI and for controlling the instrument(s) via SCPI.

A thread waiting for a *OPC? thus will not block the GUI or the communication with other instruments.

21.1.6 Status Reporting System

The status reporting system stores all information on the current operating state of the instrument, and on errors which have occurred. This information is stored in the status

registers and in the error queue. Both can be queried via GPIB bus or LAN interface (STATus... commands).

21.1.6.1 Structure of a SCPI Status Register

Each standard SCPI register consists of 5 parts. Each part has a width of 16 bits and has different functions. The individual bits are independent of each other, i.e. each hardware status is assigned a bit number which is valid for all five parts. Bit 15 (the most significant bit) is set to zero for all parts. Thus the contents of the register parts can be processed by the controller as positive integers.

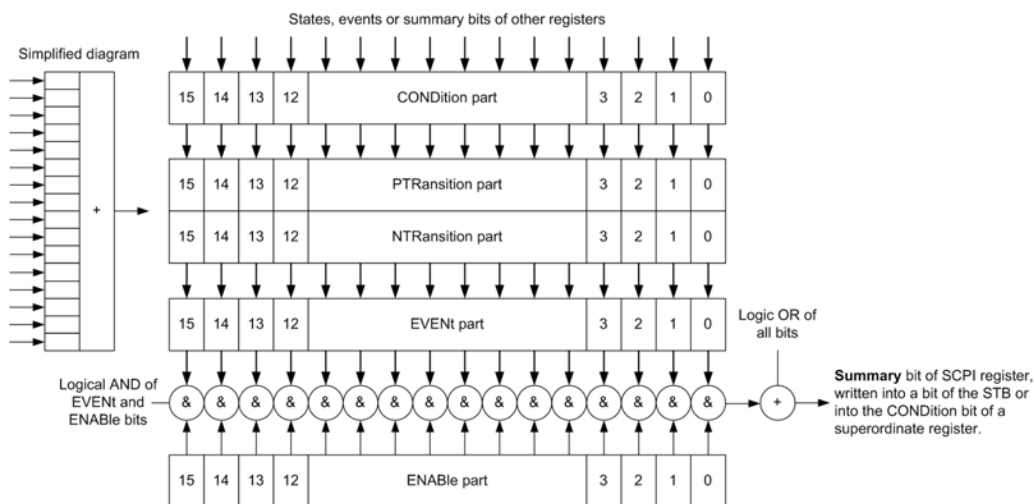

Fig. 21-1: The status-register model

Description of the five status register parts

The five parts of a SCPI register have different properties and functions:

- CONDition**
 The CONDition part is written into directly by the hardware or the sum bit of the next lower register. Its contents reflect the current instrument status. This register part can only be read, but not written into or cleared. Its contents are not affected by reading.
- PTRansition / NTRansition**
 The two transition register parts define which state transition of the CONDition part (none, 0 to 1, 1 to 0 or both) is stored in the EVENT part.
 The **Positive-TTransition** part acts as a transition filter. When a bit of the CONDition part is changed from 0 to 1, the associated PTR bit decides whether the EVENT bit is set to 1.
 - PTR bit =1: the EVENT bit is set.
 - PTR bit =0: the EVENT bit is not set.
 This part can be written into and read as required. Its contents are not affected by reading.

The **Negative-TRansition** part also acts as a transition filter. When a bit of the `CONDition` part is changed from 1 to 0, the associated `NTR` bit decides whether the `EVENT` bit is set to 1.

- `NTR` bit =1: the `EVENT` bit is set.
- `NTR` bit =0: the `EVENT` bit is not set.

This part can be written into and read as required. Its contents are not affected by reading.

- **EVENT**

The `EVENT` part indicates whether an event has occurred since the last reading, it is the "memory" of the condition part. It only indicates events passed on by the transition filters. It is permanently updated by the instrument. This part can only be read by the user. Reading the register clears it. This part is often equated with the entire register.

- **ENABLE**

The `ENABLE` part determines whether the associated `EVENT` bit contributes to the sum bit (see below). Each bit of the `EVENT` part is "ANDed" with the associated `ENABLE` bit (symbol '&'). The results of all logical operations of this part are passed on to the sum bit via an "OR" function (symbol '+').

`ENABLE` bit = 0: the associated `EVENT` bit does not contribute to the sum bit

`ENABLE` bit = 1: if the associated `EVENT` bit is "1", the sum bit is set to "1" as well.

This part can be written into and read by the user as required. Its contents are not affected by reading.

Sum bit

The sum bit is obtained from the `EVENT` and `ENABLE` part for each register. The result is then entered into a bit of the `CONDition` part of the higher-order register.

The instrument automatically generates the sum bit for each register. Thus an event can lead to a service request throughout all levels of the hierarchy.

21.1.6.2 Hierarchy of status registers

As shown in the following figure, the status information is of hierarchical structure.

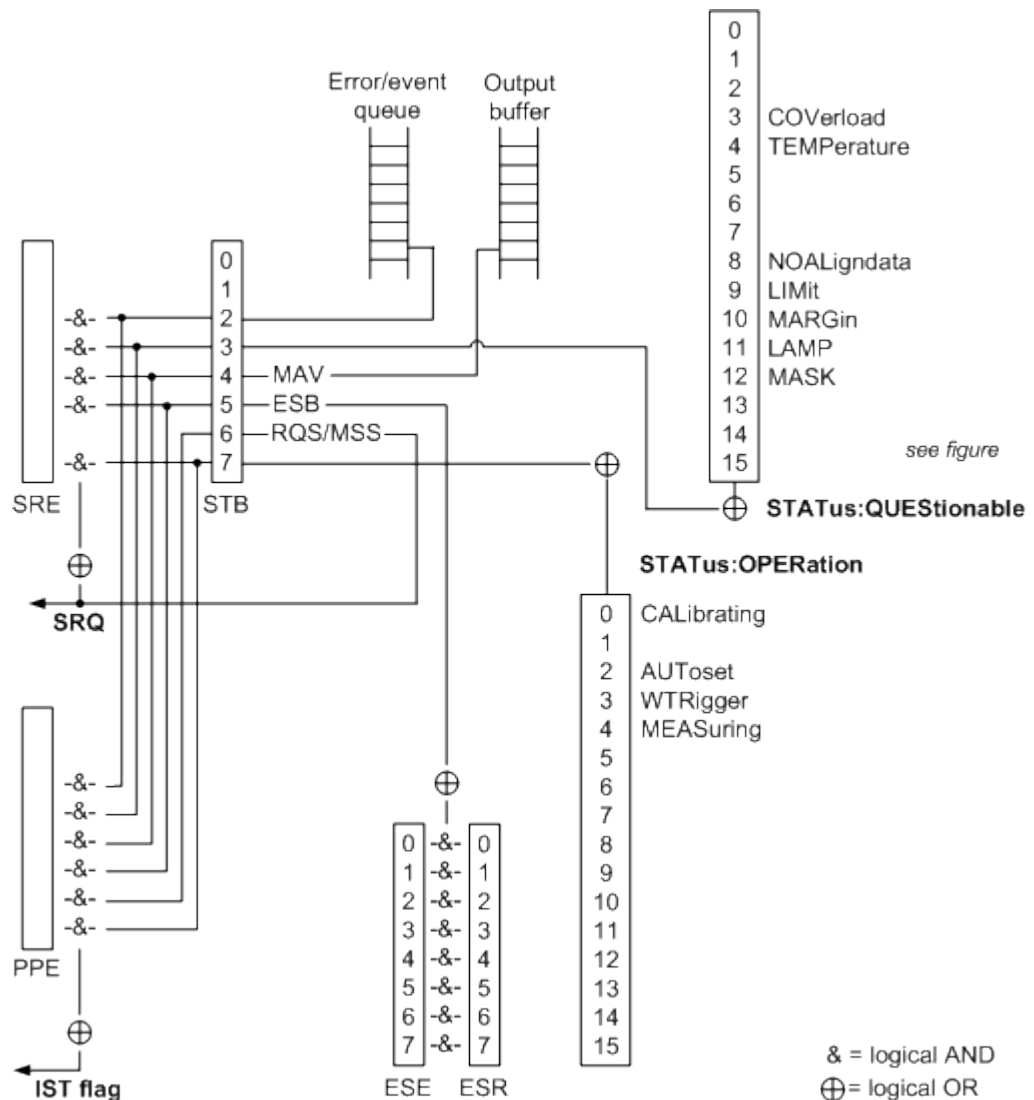

Fig. 21-2: Overview of the status registers hierarchy

- **STB, SRE**
 The STatus Byte (STB) register and its associated mask register Service Request Enable (SRE) form the highest level of the status reporting system. The STB provides a rough overview of the instrument status, collecting the information of the lower-level registers.
- **ESR, SCPI registers**
 The STB receives its information from the following registers:
 - The Event Status Register (ESR) with the associated mask register standard Event Status Enable (ESE).
 - The STATUS:OPERation and STATUS:QUESTIONable registers which are defined by SCPI and contain detailed information on the instrument.
- **IST, PPE**

The `IST` flag ("Individual Status"), like the `SRQ`, combines the entire instrument status in a single bit. The `PPE` fulfills the same function for the `IST` flag as the `SRE` for the service request.

- **Output buffer**

The output buffer contains the messages the instrument returns to the controller. It is not part of the status reporting system but determines the value of the `MAV` bit in the `STB` and thus is represented in the overview.

All status registers have the same internal structure.



SRE, ESE

The service request enable register `SRE` can be used as `ENABLE` part of the `STB` if the `STB` is structured according to SCPI. By analogy, the `ESE` can be used as the `ENABLE` part of the `ESR`.

21.1.6.3 Contents of the Status Registers

In the following sections, the contents of the status registers are described in more detail.

Status Byte (STB) and Service Request Enable Register (SRE)

The `Status Byte` (STB) is already defined in IEEE 488.2. It provides a rough overview of the instrument status by collecting the pieces of information of the lower registers. A special feature is that bit 6 acts as the sum bit of the remaining bits of the status byte.

The STB can thus be compared with the `CONDition` part of an SCPI register and assumes the highest level within the SCPI hierarchy.

The STB is read using the command `*STB?` or a serial poll.

The `Status Byte` (STB) is linked to the `Service Request Enable` (SRE) register. Each bit of the STB is assigned a bit in the SRE. Bit 6 of the SRE is ignored. If a bit is set in the SRE and the associated bit in the STB changes from 0 to 1, a service request (SRQ) is generated. The SRE can be set using the command `*SRE` and read using the command `*SRE?`.

Table 21-3: Meaning of the bits used in the status byte

Bit No.	Meaning
0...1	Not used
2	Error Queue not empty The bit is set when an entry is made in the error queue. If this bit is enabled by the SRE, each entry of the error queue generates a service request. Thus an error can be recognized and specified in greater detail by polling the error queue. The poll provides an informative error message. This procedure is to be recommended since it considerably reduces the problems involved with remote control.

Bit No.	Meaning
3	<p>QUESTionable status register summary bit</p> <p>The bit is set if an <code>EVENT</code> bit is set in the <code>QUESTionable</code> status register and the associated <code>ENABLe</code> bit is set to 1. A set bit indicates a questionable instrument status, which can be specified in greater detail by querying the <code>STATus:QUESTionable</code> status register.</p>
4	<p>MAV bit (message available)</p> <p>The bit is set if a message is available in the output queue which can be read. This bit can be used to enable data to be automatically read from the instrument to the controller.</p>
5	<p>ESB bit</p> <p>Sum bit of the event status register. It is set if one of the bits in the event status register is set and enabled in the event status enable register. Setting of this bit indicates a serious error which can be specified in greater detail by polling the event status register.</p>
6	<p>MSS bit (master status summary bit)</p> <p>The bit is set if the instrument triggers a service request. This is the case if one of the other bits of this registers is set together with its mask bit in the service request enable register <code>SRE</code>.</p>
7	<p><code>STATus:OPERation</code> status register summary bit</p> <p>The bit is set if an <code>EVENT</code> bit is set in the <code>OPERation</code> status register and the associated <code>ENABLe</code> bit is set to 1. A set bit indicates that the instrument is just performing an action. The type of action can be determined by querying the <code>STATus:OPERation</code> status register.</p>

IST Flag and Parallel Poll Enable Register (PPE)

As with the `SRQ`, the `IST` flag combines the entire status information in a single bit. It can be read by means of a parallel poll (see "[Parallel Poll](#)" on page 661) or using the command `*IST?`.

The parallel poll enable register (`PPE`) determines which bits of the `STB` contribute to the `IST` flag. The bits of the `STB` are "ANDed" with the corresponding bits of the `PPE`, with bit 6 being used as well in contrast to the `SRE`. The `IST` flag results from the "ORing" of all results. The `PPE` can be set using commands `*PRE` and read using command `*PRE?`.

Event Status Register (ESR) and Event Status Enable Register (ESE)

The `ESR` is defined in IEEE 488.2. It can be compared with the `EVENT` part of a `SCPI` register. The event status register can be read out using command `*ESR?`.

The `ESE` corresponds to the `ENABLe` part of a `SCPI` register. If a bit is set in the `ESE` and the associated bit in the `ESR` changes from 0 to 1, the `ESB` bit in the `STB` is set. The `ESE` register can be set using the command `*ESE` and read using the command `*ESE?`.

Table 21-4: Meaning of the bits used in the event status register

Bit No.	Meaning
0	<p>Operation Complete</p> <p>This bit is set on receipt of the command <code>*OPC</code> exactly when all previous commands have been executed.</p>
1	Not used

Bit No.	Meaning
2	<p>Query Error</p> <p>This bit is set if either the controller wants to read data from the instrument without having sent a query, or if it does not fetch requested data and sends new instructions to the instrument instead. The cause is often a query which is faulty and hence cannot be executed.</p>
3	<p>Device-dependent Error</p> <p>This bit is set if a device-dependent error occurs. An error message with a number between -300 and -399 or a positive error number, which denotes the error in greater detail, is entered into the error queue.</p>
4	<p>Execution Error</p> <p>This bit is set if a received command is syntactically correct but cannot be performed for other reasons. An error message with a number between -200 and -300, which denotes the error in greater detail, is entered into the error queue.</p>
5	<p>Command Error</p> <p>This bit is set if a command is received, which is undefined or syntactically incorrect. An error message with a number between -100 and -200, which denotes the error in greater detail, is entered into the error queue.</p>
6	<p>User Request</p> <p>This bit is set when the instrument is switched over to manual control.</p>
7	<p>Power On (supply voltage on)</p> <p>This bit is set on switching on the instrument.</p>

STATus:OPERation Register

In the `CONDition` part, this register contains information on which actions the instrument is executing. In the `EVENT` part, it contains information on which actions the instrument has executed since the last reading.

It can be read using the commands `STATus:OPERation:CONDition?` or `STATus:OPERation[:EVENT]?`, see also [chapter 21.2.23.1, "STATus:OPERation Register"](#), on page 1123.

Table 21-5: Bits in the STATus:OPERation register

Bit No.	Meaning
0	<p><code>CALibrating</code></p> <p>This bit is set as long as the instrument is performing a self alignment or a selftest.</p>
1	Not used
2	<p><code>AUToSet</code></p> <p>This bit is set while the instrument is performing an auto setup.</p>
3	<p><code>WTRigger</code></p> <p>This bit is set while the instrument is waiting for the trigger.</p>
4	<p><code>MEASuring</code></p> <p>The bit is set as long as an acquisition - sampling and postprocessing - is running. In run continuous mode, the bit is always set.</p>
5 - 15	Not used

STATus:QUEStionable Register

This register contains information about indefinite states which may occur if the unit is operated without meeting the specifications. It can be read using the commands `STATus:QUEStionable:CONDition?` and `STATus:QUEStionable[:EVENT]?`

The remote commands for the STATus:QUEStionable register are described in [chapter 21.2.23.2, "STATus:QUEStionable Registers"](#), on page 1123 .

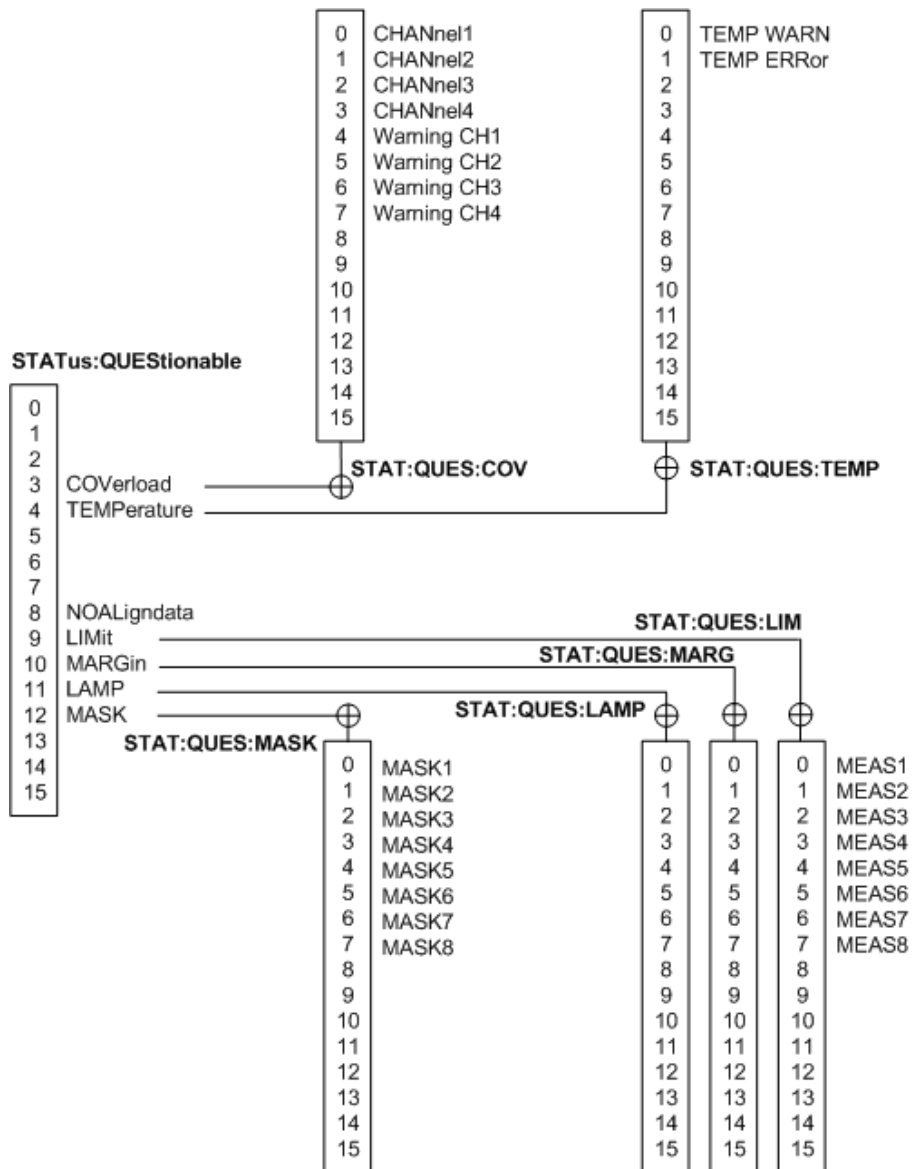

Fig. 21-3: Overview of the STATus:QUEStionable register

Table 21-6: Bits in the STATus:QUEStionable register

Bit No.	Meaning
0 to 2	not used
3	COVerload This bit is set if a questionable channel overload occurs (see "STATus:QUEStionable:COVerload register" on page 658).
4	TEMPerature This bit is set if a questionable temperature occurs (see "STATus:QUEStionable:TEMPerature register" on page 659).
5 to 7	Not used
8	NOALigndata This bit is set if no alignment data is available - the instrument is uncalibrated.
9	LIMit This bit is set if a limit value is violated (see "STATus:QUEStionable:LIMit, STATus:QUEStionable:MARGin, STATus:QUEStionable:LAMP registers" on page 659).
10	MARGin This bit is set if a margin value is violated (see "STATus:QUEStionable:LIMit, STATus:QUEStionable:MARGin, STATus:QUEStionable:LAMP registers" on page 659).
11	LAMP (Low AMPlitude) This bit is set if the magnitude of the signal is too low to get reliable measurement results.
12	MASK This bit is set if a mask value is violated (see "STATus:QUEStionable:MASK register" on page 659)
13 to 14	Not used
15	This bit is always 0.

STATus:QUEStionable:COVerload register

This register contains all information about overload of the channels. The bit is set if the assigned channel is overloaded, or if an overload risk occurred (overload warning).

Table 21-7: Bits in the STATus:QUEStionable:COVerload register

Bit No.	Meaning
0	Overload on CHANnel1
1	Overload on CHANnel2
2	Overload on CHANnel3
3	Overload on CHANnel4
4	Overload warning for CHANnel1
5	Overload warning for CHANnel2

Bit No.	Meaning
6	Overload warning for CHANne13
7	Overload warning for CHANne14

STATus:QUESTionable:TEMPerature register

This register contains information about the instrument's temperature.

Table 21-8: Bits in the STATus:QUESTionable:TEMPerature register

Bit No.	Meaning
0	TEMP WARN This bit is set if a temperature warning on channel 1, 2, 3 or 4 occurred.
1	TEMP ERROr This bit is set if a temperature error on channel 1, 2, 3 or 4 occurred.

STATus:QUESTionable:LIMit, STATus:QUESTionable:MARGin, STATus:QUESTionable:LAMP registers

These registers contain information about the observance of the limits or margins of measurements. For LIMit and MARGin, this bit is set if the limits or margins of the main or additional measurement of assigned measurement are violated. The LAMP (Low AMPlitude) bit is set if the magnitude of the signal is too low to get reliable measurement results.

Table 21-9: Bits in the STATus:QUESTionable:LIMit, STATus:QUESTionable.MARGin, and STATus:QUESTionable:AMP registers

Bit No.	Meaning
0	MEAS1
1	MEAS2
2	MEAS3
3	MEAS4
4	MEAS5
5	MEAS6
6	MEAS7
7	MEAS8

STATus:QUESTionable:MASK register

This register contains information about the violation of masks. This bit is set if the assigned mask is violated.

Table 21-10: Bits in the STATus:QUESTionable:MASK register

Bit No.	Meaning
0	MASK1
1	MASK2

Bit No.	Meaning
2	MASK3
3	MASK4
4	MASK5
5	MASK6
6	MASK7
7	MASK8

21.1.6.4 Application of the Status Reporting System

The purpose of the status reporting system is to monitor the status of one or several devices in a measuring system. To do this and react appropriately, the controller must receive and evaluate the information of all devices. The following standard methods are used:

- **Service request (SRQ)** initiated by the instrument
- **Serial poll** of all devices in the bus system, initiated by the controller in order to find out who sent a SRQ and why
- **Parallel poll** of all devices
- Query of a **specific instrument status** by means of commands
- Query of the **error queue**

Service Request

Under certain circumstances, the instrument can send a service request (SRQ) to the controller. Usually this service request initiates an interrupt at the controller, to which the control program can react appropriately. As evident from [figure 21-2](#), an SRQ is always initiated if one or several of bits 2, 3, 4, 5 or 7 of the status byte are set and enabled in the SRE. Each of these bits combines the information of a further register, the error queue or the output buffer. The `ENABLe` parts of the status registers can be set such that arbitrary bits in an arbitrary status register initiate an SRQ. In order to make use of the possibilities of the service request effectively, all bits should be set to "1" in enable registers SRE and ESE.

The SRQ is the only possibility for the instrument to become active on its own. Each controller program should cause the instrument to initiate a service request if errors occur. The program should react appropriately to the service request.

Serial Poll

In a serial poll, just as with command `*STB`, the status byte of an instrument is queried. However, the query is realized via interface messages and is thus clearly faster.

The serial poll method is defined in IEEE 488.1 and used to be the only standard possibility for different instruments to poll the status byte. The method also works for instruments which do not adhere to SCPI or IEEE 488.2.

The serial poll is mainly used to obtain a fast overview of the state of several instruments connected to the controller.

Parallel Poll

In a parallel poll, up to eight instruments are simultaneously requested by the controller using a single command to transmit 1 bit of information each on the data lines, i.e., to set the data line allocated to each instrument to a logical "0" or "1".

In addition to the SRE register, which determines the conditions under which an SRQ is generated, there is a Parallel Poll Enable register (PPE) which is ANDed with the STB bit by bit, considering bit 6 as well. This register is ANDed with the STB bit by bit, considering bit 6 as well. The results are ORed, the result is possibly inverted and then sent as a response to the parallel poll of the controller. The result can also be queried without parallel poll using the command `*IST?`.

The instrument first has to be set for the parallel poll using the command `PPC`. This command allocates a data line to the instrument and determines whether the response is to be inverted. The parallel poll itself is executed using `PPE`.

The parallel poll method is mainly used to find out quickly which one of the instruments connected to the controller has sent a service request. To this effect, SRE and PPE must be set to the same value.

Query of an instrument status

Each part of any status register can be read using queries. There are two types of commands:

- The common commands `*ESR?`, `*IDN?`, `*IST?`, `*STB?` query the higher-level registers.
- The commands of the `STATUS` system query the SCPI registers (`STATUS:QUESTIONABLE...`)

The returned value is always a decimal number that represents the bit pattern of the queried register. This number is evaluated by the controller program.

Queries are usually used after an SRQ in order to obtain more detailed information on the cause of the SRQ.

Decimal representation of a bit pattern

The STB and ESR registers contain 8 bits, the SCPI registers 16 bits. The contents of a status register are specified and transferred as a single decimal number. To make this possible, each bit is assigned a weighted value. The decimal number is calculated as the sum of the weighted values of all bits in the register that are set to 1.

Bits	0	1	2	3	4	5	6	7	...
Weight	1	2	4	8	16	32	64	128	...

Example:

The decimal value 40 = 32 + 8 indicates that bits no. 3 and 5 in the status register (e.g. the `QUESTIONABLE` status summary bit and the `ESB` bit in the `STATUS` Byte) are set.

Error Queue

Each error state in the instrument leads to an entry in the error queue. The entries of the error queue are detailed plain text error messages that can be looked up in the Error Log or queried via remote control using `SYSTEM:ERROR[:NEXT]?` or `SYSTEM:ERROR:ALL?`. Each call of `SYSTEM:ERROR[:NEXT]?` provides one entry from the error queue. If no error messages are stored there any more, the instrument responds with 0, "No error".

The error queue should be queried after every SRQ in the controller program as the entries describe the cause of an error more precisely than the status registers. Especially in the test phase of a controller program the error queue should be queried regularly since faulty commands from the controller to the instrument are recorded there as well.

21.1.6.5 Reset Values of the Status Reporting System

The following table contains the different commands and events causing the status reporting system to be reset. None of the commands, except `*RST` and `SYSTEM:PRESet`, influence the functional instrument settings. In particular, `DCL` does not change the instrument settings.

Table 21-11: Reset of the status reporting system

Event	Switching on supply voltage Power-On-Status-Clear		DCL, SDC (Device Clear, Selected Device Clear)	*RST or SYS- Tem:PRE- Set	STA- Tus:PRE- Set	*CLS
	0	1				
Clear STB, ESR	-	yes	-	-	-	yes
Clear SRE, ESE	-	yes	-	-	-	-
Clear PPE	-	yes	-	-	-	-
Clear EVENT parts of the registers	-	yes	-	-	-	yes
Clear ENABLE parts of all OPERATION and QUESTIONABLE registers; Fill ENABLE parts of all other registers with "1".	-	yes	-	-	yes	-
Fill PTRansition parts with "1"; Clear NTRansition parts	-	yes	-	-	yes	-
Clear error queue	yes	yes	-	-	-	yes
Clear output buffer	yes	yes	yes	1)	1)	1)

Event	Switching on supply voltage		DCL, SDC (Device Clear, Selected Device Clear)	*RST or SYS-Tem:PRE-Set	STA-Tus:PRE-Set	*CLS
	Power-On-Status-Clear					
Effect	0	1				
Clear command processing and input buffer	yes	yes	yes	-	-	-
1) The first command in a command line that immediately follows a <PROGRAM MESSAGE TERMINATOR> clears the output buffer.						

21.1.7 General Programming Recommendations

Initial instrument status before changing settings

Manual operation is designed for maximum possible operating convenience. In contrast, the priority of remote control is the "predictability" of the instrument status. Thus, when a command attempts to define incompatible settings, the command is ignored and the instrument status remains unchanged, i.e. other settings are not automatically adapted. Therefore, control programs should always define an initial instrument status (e.g. using the *RST command) and then implement the required settings.

Command sequence

As a general rule, send commands and queries in different program messages. Otherwise, the result of the query may vary depending on which operation is performed first (see also Preventing Overlapping Execution).

Reacting to malfunctions

The service request is the only possibility for the instrument to become active on its own. Each controller program should instruct the instrument to initiate a service request in case of malfunction. The program should react appropriately to the service request.

Error queues

The error queue should be queried after every service request in the controller program as the entries describe the cause of an error more precisely than the status registers. Especially in the test phase of a controller program the error queue should be queried regularly since faulty commands from the controller to the instrument are recorded there as well.

21.2 Command Reference

This chapter provides the description of all remote commands available for R&S RTO.

21.2.1 Conventions used in Remote Command Description

Note the following conventions used in the remote command descriptions:

- **Command usage**
If not specified otherwise, commands can be used both for setting and for querying parameters.
If a command can be used for setting or querying only, or if it initiates an event, the usage is stated explicitly.
- **Parameter usage**
If not specified otherwise, a parameter can be used to set a value and it is the result of a query.
Parameters required only for setting are indicated as **Setting parameters**.
Parameters required only to refine a query are indicated as **Query parameters**.
Parameters that are only returned as the result of a query are indicated as **Return values**.
- **Conformity**
Commands that are taken from the SCPI standard are indicated as **SCPI confirmed**. All commands used by the R&S RTO follow the SCPI syntax rules.
- **Asynchronous commands**
A command which does not automatically finish executing before the next command starts executing (overlapping command) is indicated as an **Asynchronous command**.
- **Reset values (*RST)**
Default parameter values that are used directly after resetting the instrument (*RST command) are indicated as ***RST** values, if available.
- **Default unit**
This is the unit used for numeric values if no other unit is provided with the parameter.

21.2.2 Finding the Appropriate Command

In the following chapters, the commands are sorted according to the menu and dialog structure of the instrument.

A list of all commands in alphabetical order is given in the "List of Commands" at the end of this documentation.

To find the appropriate command for a setting easily, you can use the context help:

1. Enable the "Tooltip" icon on the toolbar.



2. Tap the parameter for which you need information.
The tooltip opens.
3. Tap the "Show Help" button in the lower right corner of the tooltip.

The "Help" window opens and displays the comprehensive description and the corresponding remote command.

4. Tap the remote command link to open the command description.

21.2.3 Frequently Used Parameters and Suffixes

This chapter describes in general those parameters and suffixes that are used in several subsystems.

21.2.3.1 Waveform Suffix

The numeric waveform suffix is used in some commands to indicate the source waveform number from which the reference level is taken, and to assign color tables to waveforms.



Depending on the command, not all suffix values are supported. For example, in REFLevel commands, only suffixes 2...21 are allowed. The range of supported suffix numbers is indicated in the description of the individual commands.

NOTICE

Suffix 1

Suffix 1 means that no waveform is assigned. The first waveform C1W1 corresponds to suffix number 2.

Waveform number	Description
1	None
2...4	Channel 1 waveforms: C1W1, C1W2, C1W3
5...7	Channel 2 waveforms: C2W1, C2W2, C2W3
8...10	Channel 3 waveforms: C3W1, C3W2, C3W3
11...13	Channel 4 waveforms: C4W1, C4W2, C4W3
14...17	Math waveforms: M1, M2, M3, M4
18...21	Reference waveforms: R1, R2, R3, R4
22...25	XY-waveforms: XY1, XY2, XY3, XY4
26...34	Measurement results: MRESult1, MRESult2, MRESult3, MRESult4, MRESult5, MRESult6, MRESult7, MRESult8 34 = IMResult, result of immediate measurements available on Tektronix instruments. Only relevant for Tektronix emulation (option R&S RTO-K301)
35...38	Serial buses: SBUS1, SBUS2, SBUS3, SBUS4
39...54	Digital channels: D0...D15 (option R&S RTO-B1)

Waveform number	Description
55...58	Digital buses: MSO1, MSO2, MSO3, MSO4 (option R&S RTO-B1)
59	not used
60...67	Track waveforms: TRK1, TRK2, TRK3, TRK4, TRK5, TRK6, TRK7, TRK8 Available for audio signals and jitter analysis (options R&S RTO-K5/K12)

21.2.3.2 Waveform Parameter

Many commands requires one of the waveforms to be specified as source. The following table lists all waveforms. For each command using a waveform parameter, the available waveforms are specified in the command description.

Alternatively, digital channels can be used if MSO option R&S RTO-B1 is installed. Digital and analog channels cannot be used at the same time.

For triggering on a serial bus, analog or digital input channels are required. Math and reference waveforms are not available.

Waveform	Description
C1W1 C1W2 C1W3	Channel 1 waveforms
C2W1 C2W2 C2W3	Channel 2 waveforms
C2W3 C3W1 C3W2	Channel 3 waveforms
C4W1 C4W2 C4W3	Channel 4 waveforms
M1 M2 M3 M4	Math waveforms
R1 R2 R3 R4	Reference waveforms
XY1 XY2 XY3 XY4	XY-waveforms
MRESult1 MRESult2 MRESult3 MRESult4 MRESult5 MRESult6 MRESult7 MRESult8 IMResult	Measurement results Result of immediate measurements available on Tektronix instruments. Only relevant for Tektronix emulation (option R&S RTO-K301).
SBUS1 SBUS2 SBUS3 SBUS4	Serial buses
D0 D1 D2 D3 D4 D5 D6 D7 D8 D9 D10 D11 D12 D13 D14 D15	Digital channels (option R&S RTO-B1)
MSOB1 MSOB2 MSOB3 MSOB4	Digital buses (option R&S RTO-B1)
TRK1 TRK2 TRK3 TRK4 TRK5 TRK6 TRK7 TRK8	Track waveforms (option R&S RTO-K5)

21.2.3.3 Slope Parameter

The slope parameter is used with several trigger and search condition commands.

Slope	Description
POSitive	Rising edge, that is a positive voltage change.
NEGative	Falling edge, that is a negative voltage change
EITHer	rising as well as the falling edge.

21.2.3.4 Polarity Parameter

The polarity parameter is used with several trigger and search condition commands.

Polarity	Description
POSitive	Positive going pulses.
NEGative	Negative going pulses.
EITHer	Both positive and negative going pulses.

21.2.3.5 Event Parameter

The event parameter is used with commands defining an action for mask testing, limit checks and margin checks.

Event	Description
NOAction	The action is not initiated.
SUCCess	The action is initiated if the operation finished successfully: <ul style="list-style-type: none"> Limits or margins were not exceeded during the entire measurement Mask test passed
VIOLation	The action is initiated if the operation finished with error: <ul style="list-style-type: none"> Limits or margins were violated during the measurement Mask test failed

21.2.3.6 Bit Pattern Parameter

Bit pattern parameter are required with commands triggering on address, identifier, or data pattern.

To set the pattern value, you can use either a numeric parameter as defined in the SCPI standard, or a string parameter.

Bit pattern in numeric parameter

In a numeric parameter, the values are listed byte-by-byte, with bytes separated by commas and MSB first. The default numeral format is decimal, other formats can be indicated by a format identifier (#B = binary, #H = hexadecimal, #Q = octal). Currently, no format for signed values is available.

Example: Parameter with three bytes, decimal byte values are 10, 20, 30

- TRIGger:CAN:DMIN 10,20,30

- TRIGger:CAN:DMIN #B00001010, #B00010100, #B00011110
- TRIGger:CAN:DMIN #H0A, #H14, #H1E
- TRIGger:CAN:DMIN #Q012, #Q024, #Q036

Bit pattern in string parameter

In a string, the complete binary pattern is written without separation of bytes, for example:

```
TRIGger:CAN:DMIN '000010100001010000011110'
```

Unlike a numeric parameter, the string parameter accepts wildcards for single bits (X = don't care). Whether wildcards can be used or not depends on the remote command. Usually, address and identifier parameter require unique patterns while data parameters may contain wildcards.

Mostly the length of the bit pattern is defined, for example, by the I²C address type, the CAN identifier type, or the data length code. In these cases, it is recommended that you enter the complete bit pattern. If you enter a shorter pattern, the instrument fills up the pattern with X bits to the right of the defined pattern.

Example: You want to trigger on an 11 bit CAN address and enter the bit pattern '11100011' (8 bits only). The instrument uses the pattern '11100011XXX' for triggering.

Query for a pattern

The pattern format for the return value of a pattern is defined by the [FORMat:BPATtern](#) command.

21.2.4 Common Commands

Common commands are described in the IEEE 488.2 (IEC 625-2) standard. These commands have the same effect and are employed in the same way on different devices. The headers of these commands consist of "*" followed by three letters. Many common commands are related to the Status Reporting System.

Available common commands:

*CAL?	669
*CLS	669
*ESE	669
*ESR?	669
*IDN?	669
*IST?	670
*OPC	670
*OPT?	670
*PCB	670
*PRE	671
*PSC	671
*RCL	671
*RST	671
*SAV	671

*SRE.....	672
*STB?.....	672
*TRG.....	672
*TST?.....	672
*WAI.....	672

*CAL?

Performs a self-alignment of the instrument and then generates a status response. Return values $\neq 0$ indicate an error.

Usage: Query only

*CLS

Clear status

Sets the status byte (STB), the standard event register (ESR) and the `EVENT` part of the `QUESTIONABLE` and the `OPERATION` registers to zero. The command does not alter the mask and transition parts of the registers. It clears the output buffer.

Usage: Setting only

*ESE <Value>

Event status enable

Sets the event status enable register to the specified value. The query returns the contents of the event status enable register in decimal form.

Parameters:

<Value> Range: 0 to 255

*ESR?

Event status read

Returns the contents of the event status register in decimal form and subsequently sets the register to zero.

Return values:

<Contents> Range: 0 to 255

Usage: Query only

*IDN?

Identification

Returns the instrument identification.

Return values:

<ID> "Rohde&Schwarz,<device type>,<serial number>,<firmware version>"

Example:

Rohde&Schwarz,RTO,1316.1000k14/200153,1.30.0.25

Usage:

Query only

***IST?**

Individual status query

Returns the contents of the IST flag in decimal form. The IST flag is the status bit which is sent during a parallel poll.

Return values:

<ISTflag> 0 | 1

Usage:

Query only

***OPC**

Operation complete

Sets bit 0 in the event status register when all preceding commands have been executed. This bit can be used to initiate a service request. The query form writes a "1" into the output buffer as soon as all preceding commands have been executed. This is used for command synchronization.

***OPT?**

Option identification query

Queries the options included in the instrument. For a list of all available options and their description refer to the CD-ROM.

Return values:

<Options> The query returns a list of options. The options are returned at fixed positions in a comma-separated string. A zero is returned for options that are not installed.

Usage:

Query only

***PCB <Address>**

Pass control back

Indicates the controller address to which remote control is returned after termination of the triggered action.

Setting parameters:

<Address> Range: 0 to 30

Usage:

Setting only

***PRE** <Value>

Parallel poll register enable

Sets parallel poll enable register to the indicated value. The query returns the contents of the parallel poll enable register in decimal form.

Parameters:

<Value> Range: 0 to 255

***PSC** <Action>

Power on status clear

Determines whether the contents of the `ENABLE` registers are preserved or reset when the instrument is switched on. Thus a service request can be triggered when the instrument is switched on, if the status registers ESE and SRE are suitably configured. The query reads out the contents of the "power-on-status-clear" flag.

Parameters:

<Action> 0 | 1
0
The contents of the status registers are preserved.
1
Resets the status registers.

***RCL** <Number>

Recall

Loads the instrument settings from an intermediate memory identified by the specified number. The instrument settings can be stored to this memory using the command `*SAV` with the associated number.

It also activates the instrument settings which are stored in a file and loaded using `MMEMory:LOAD:STATe`.

***RST**

Reset

Sets the instrument to a defined default status. The default settings are indicated in the description of commands.

Usage: Setting only

***SAV** <Number>

Save

Stores the current instrument settings under the specified number in an intermediate memory. The settings can be recalled using the command [*RCL](#) with the associated number.

To transfer the stored instrument settings to a file, use [MMEMoRY:STORe:STATe](#).

***SRE** <Contents>

Service request enable

Sets the service request enable register to the indicated value. This command determines under which conditions a service request is triggered.

Parameters:

<Contents> Contents of the service request enable register in decimal form.
 Bit 6 (MSS mask bit) is always 0.
 Range: 0 to 255

***STB?**

Status byte query

Reads the contents of the status byte in decimal form.

Usage: Query only

***TRG**

Trigger

Triggers all actions waiting for a trigger event. In particular, [*TRG](#) generates a manual trigger signal. This common command complements the commands of the [TRIGger](#) subsystem.

Usage: Event

***TST?**

Self test query

Triggers selftests of the instrument and returns an error code in decimal form (see Service Manual supplied with the instrument). "0" indicates no errors occurred.

Usage: Query only

***WAI**

Wait to continue

Prevents servicing of the subsequent commands until all preceding commands have been executed and all signals have settled (see also command synchronization and [*OPC](#)).

Usage: Event

21.2.5 General Remote Settings

This chapter describes commands that have effect on many other remote commands in different applications of the instrument.

FORMat[:DATA]	673
FORMat:BPATtern	674
SYSTem:DISPlay:UPDate	675
SYSTem:KLOCK	675
SYSTem:LANGuage	675

FORMat[:DATA] <Format>, [<Length>]

Selects the data format that is used for transmission of waveform data from the instrument to the controlling computer.

Waveform data can be retrieved using the following commands:

- [CHANnel<m>\[:WAVeform<n>\]:DATA\[:VALues\]?](#)
- [CALCulate:MATH<m>:DATA\[:VALues\]?](#)
- [REFCurve<m>:DATA\[:VALues\]?](#)
- [DIGital<m>:DATA\[:VALues\]?](#)

The content of the data stream can be defined with [EXPort:WAVeform:INCXvalues](#)

Parameters:

<Format>,[<Length>] ASCII | REAL,32 | INT,8

ASCII

Data values are returned in ASCII format as a list of comma separated values in floating point format. The length can be omitted. It is 0 which means that the instrument selects the number of digits to be returned. The query returns both values (ASC, 0).

REAL,32

Binary format. The data is stored as binary data (Definite Length Block Data according to IEEE 488.2). Each waveform value is formatted in 32 Bit IEEE 754 Floating-Point-Format.

The schema of the result string is as follows:

#41024<value1><value2>...<value n> with:

#4 = number of digits (= 4 in the example) of the following number

1024 = number of following data bytes (= 1024 in the example)

<value> = 4-byte floating point values

If the data exceeds 1 GB, the result string starts with header #0 (unknown length), followed by the data values.

INT,8

Signed integer data with length 8 bit. It defines that

CHANnel<m>[:WAVeform<n>]:DATA[:VALues]? returns the raw sample data of the ADC as integers. The result string has the same schema as the REAL format.

CALCulate:MATH<m>:DATA[:VALues]? and

REFCurve<m>:DATA[:VALues]? return the waveform data in 8 bit integer format. This format reduces the file size but decreases also the precision of the values.

Data conversion is described in "[Raw \(ADC direct\)](#)" on page 378.

For digital channel data, the format is not available.

[EXPORT:WAVeform:INCXvalues](#) must be set OFF.

*RST: ASCII

Example:

FORMat:DATA REAL,32

FORMat:DATA?

REAL,32

Usage:

SCPI confirmed

FORMat:BPATtern <BitPatternFormat>

Sets the format for all remote bit pattern queries.

Parameters:

<BitPatternFormat> DEC | HEX | OCT | BIN | ASCII | STRG

*RST: HEX

Firmware/Software: V 1.25

SYSTem:DISPlay:UPDate <Enable>

Defines whether the display is updated while the instrument is in the remote state. If the display is switched off, the normal GUI is replaced by a static image while the instrument is in the remote state. Switching off the display can speed up the measurement. This is the recommended state.

See also: [chapter 21.1.2.2, "Using the display during remote control"](#), on page 637

Parameters:

<Enable> **ON | 1:** Display is shown and updated during remote control
OFF | 0: Display shows static image during remote control

Example:

```
SYSTem:DISPlay:UPDate 1
Switch on the display update.
```

SYSTem:KLOCK <Enable>

Locks or unlocks the local controls of the instrument. This includes the front panel keys, the keyboard, or other local interfaces. except for the "View" button on the display.

Parameters:

<Enable> **ON | 1:** Locks the local keys
OFF | 0: Keys are unlocked

Usage:

SCPI confirmed

SYSTem:LANGuage <Language>

Defines the remote control behavior of the instrument and sets the remote control command set.

Parameters:

<Language> String value. Available values:
 'SCPI': R&S RTO remote command set is used.
 "DPO7000" or 'TDS540': Compatible remote command set of Tektronix oscilloscopes DPO7000 or TDS540 is used. If one of these emulation modes is used, you can define alternative responses to the `IDN*?` and `OPT*?` commands on the SETUP > "Remote settings" tab.

Firmware/Software: V 1.35

Options: R&S RTO-K301

21.2.6 Acquisition and Setup

- [Starting and Stopping Acquisition](#)..... 676
- [Time Base](#)..... 676
- [Acquisition](#)..... 678
- [Vertical](#)..... 685

• Waveform Data	689
• Probes	690
• Digital Filter	699
• Skew	700
• Reference (OCXO Option R&S RTO)-B4	701

21.2.6.1 Starting and Stopping Acquisition

RUNContinuous	676
RUN	676
RUNSingle	676
SINGLE	676
STOP	676

RUNContinuous

RUN

Starts the continuous acquisition.

Usage: Event
 Asynchronous command

RUNSingle

SINGLE

Starts a defined number of acquisition cycles. The number of cycles is set with [ACquire:COUNT](#).

Usage: Event
 Asynchronous command

STOP

Stops the running acquisition.

Usage: Event
 Asynchronous command

21.2.6.2 Time Base

TIMebase:SCALE	677
TIMebase:RANGe	677
TIMebase:DIVisions?	677
TIMebase:HORizontal:POSition	677
TIMebase:REFerence	678
TIMebase:ROLL:ENABLE	678
TIMebase:ROLL:MTIME	678

TIMEbase:SCALE <TimeScale>

Sets the horizontal scale - the time per division on the x-axis - for all channel and math waveforms.

The setting accuracy depends on the current resolution (sample rate) and the setting for resolution enhancement:

- In interpolated time mode if sample rate > ADC sample rate:
Any value for the horizontal scale can be set due to the interpolation factor.
- In real time mode and equivalent time mode for all sample rates; and in interpolated time mode if sample rate < ADC sample rate:
The resolution is an integer multiple of the ADC sample rate.

Parameters:

<TimeScale> Range: 25E-12 to 50
 Increment: 1E-12
 *RST: 10E-9
 Default unit: s/div

TIMEbase:RANGe <AcquisitionTime>

Defines the time of one acquisition, that is the time across the 10 divisions of the diagram: $TimeScale * 10$.

Parameters:

<AcquisitionTime> Range: 250E-12 to 500
 Increment: 1E-12
 *RST: 0.5
 Default unit: s

TIMEbase:DIVisions?

Queries the number of horizontal divisions on the screen. The number cannot be changed.

Return values:

<HorizDivCount> Range: 4 to 20
 Increment: 2
 *RST: 10

Usage: Query only

TIMEbase:HORizontal:POSition <RescaleCenterTime>

Defines the time distance between the reference point and the trigger point (the zero point of the diagram). The reference point marks the rescaling center of the time scale.

Parameters:

<RescaleCenterTime>Range: -100E+24 to 100E+24
 Increment: 1E-12
 *RST: 0
 Default unit: s

Firmware/Software: V 1.50

TIMEbase:REFerence <RescaleCenterPos>

Sets the position of the reference point in % of the screen. The reference point marks the rescaling center of the time scale. If you modify the time scale, the reference point remains fixed on the screen, and the scale is stretched or compresses to both sides of the reference point.

Parameters:

<RescaleCenterPos> Range: 0 to 100
 Increment: 1
 *RST: 50
 Default unit: %

TIMEbase:ROLL:ENABLE <Mode>

Activates the automatic roll mode.

Parameters:

<Mode> AUTO | OFF
 AUTO: the instrument activates the roll mode under specific conditions.
 See: "[Mode](#)" on page 107
 *RST: AUTO

TIMEbase:ROLL:MTIME <MinHorizGain>

The roll mode is enabled automatically if the acquisition time exceeds the given value, and if [TIMEbase:ROLL:ENABLE](#) is set to AUTO.

Parameters:

<MinHorizGain> Treshold value for roll mode enabling.
 Range: 1 to 600
 Increment: 1
 *RST: 10
 Default unit: s

21.2.6.3 Acquisition

AUToscale	679
ACQUIRE:POINts:AUTO	679
ACQUIRE:POINts:MAXimum	679

ACQUIRE:POINTS:ARATE?	680
ACQUIRE:SRATE	680
ACQUIRE:RESOLUTION	680
ACQUIRE:POINTS[:VALUE]	680
ACQUIRE:MODE	681
ACQUIRE:INTERPOLATE	681
CHANNEL<m>[:WAVEFORM<n>][:STATE]	682
CHANNEL<m>[:WAVEFORM<n>]:TYPE	682
CHANNEL<m>[:WAVEFORM<n>]:ARITHMETICS	683
ACQUIRE:COUNT	683
ACQUIRE:ARESET:IMMEDIATE	683
ACQUIRE:ARESET:MODE	684
ACQUIRE:ARESET:TIME	684
ACQUIRE:ARESET:WFMCOUNT	684
ACQUIRE:SEGMENTED:STATE	684
ACQUIRE:SEGMENTED:MAX	685
ACQUIRE:SEGMENTED:AUTOPLAY	685

AUTOscale

Performs an autoset process: analyzes the enabled channel signals, and obtains appropriate horizontal, vertical, and trigger settings to display stable waveforms.

Usage: Event
 Asynchronous command

ACQUIRE:POINTS:AUTO <RecLengthManual>

Selection to keep constant either the resolution or the record length when you adjust the time scale (`TIMEbase:SCALE`) or acquisition time (`TIMEbase:RANGE`).

Parameters:

<RecLengthManual> RESolution | RECLength

RESolution

Resolution is kept constant. Set the required resolution value with `ACQUIRE:RESOLUTION`.

RECLength

The record length is kept constant. Set the required record length value with `ACQUIRE:POINTS[:VALUE]`.

*RST: RESolution

ACQUIRE:POINTS:MAXimum <RecLengthLim>

Sets a limit for the record length to prevent very large records. This value only takes effect if a constant resolution is selected with `ACQUIRE:POINTS:AUTO`. If you increase the time scale, the resolution remains constant and the record length increases until the limit is reached. Further increase of the time scale changes the resolution and keeps the record length limit.

Parameters:

<RecLengthLim> Range: 1000 to 1E+9
 Increment: 2
 *RST: 1E+6
 Default unit: Sa

ACQUIRE:POINTS:ARATE?

Retrieves the sample rate of the ADC, that is the number of points that are sampled by the ADC in one second.

Return values:

<ADCSampleRate> Range: 10E+9 and 20E+9
 *RST: 10E+9
 Default unit: Sa/s

Usage: Query only

ACQUIRE:SRATE <SampleRate>

Defines the sample rate, that is the number of recorded waveform samples per second.

See also: "[Sample rate](#)" on page 108.

Parameters:

<SampleRate> Range: 2 to 20E+12
 Increment: 1
 *RST: 10E+9
 Default unit: Sa/s

ACQUIRE:RESOLUTION <Resolution>

Indicates the time between two waveform points in the record.

Parameters:

<Resolution> A fine resolution with low values produces a more precise waveform record.
 Range: 1E-15 to 0.5
 Increment: 10E-12
 *RST: 100E-12
 Default unit: s

ACQUIRE:POINTS[:VALue] <RecordLength>

Indicates the record length, the number of recorded waveform points that build the waveform across the acquisition time. [:VALue] can be omitted.

Parameters:

<RecordLength> Number of recorded waveform points.
 Range: 1000 to 1000000000
 Increment: 2
 *RST: 1000
 Default unit: Sa

ACQUIRE:MODE <EnhancementMode>

Selects the method of adding waveform points to the samples of the ADC in order to fill the record length.

See also: "[Resolution enhancement](#)" on page 110.

Parameters:

<EnhancementMode> RTIME | ITIME | ETIME

RTIME

Real Time Mode: The sampled points of the input signal are used to build the waveform, no waveform points are added.

ITIME

Interpolated time: Interpolation of waveform points with the method set by the interpolation mode, see [ACQUIRE:INTERPOLATE](#) on page 681.

ETIME

Equivalent time: The waveform points are taken from several acquisitions of a repetitive signal at a different time in relation to the trigger point.

*RST: ITIME

ACQUIRE:INTERPOLATE <IntpolMode>

Selects the interpolation method if [ACQUIRE:MODE ITIME](#) (interpolated time) is set for enhancement.

See also: "[Interpolation mode](#)" on page 111.

Parameters:

<IntpolMode> LINear | SINX | SMHD

LINear

Linear interpolation between two adjacent sample points

SINX

Interpolation by means of a $\sin(x)/x$ curve.

SMHD

Sample/Hold causes a histogram-like interpolation.

*RST: SINX

CHANnel<m>[:WAVEform<n>][:STATe] <State>

Activates or deactivates a waveform. [:STATe] can be omitted.

Suffix:

<m>	1..4 Selects the input channel.
<n>	1..3 Selects the waveform. For each channel, up to three waveforms can be analyzed. If WAVEform<n> is omitted, waveform 1 is addressed.

Parameters:

<State>	ON OFF
*RST:	OFF

CHANnel<m>[:WAVEform<n>]:TYPE <DecimationMode>

Selects the method to reduce the data stream of the ADC to a stream of waveform points with lower sample rate.

See also: "[Decimation](#)" on page 112.

Suffix:

<m>	1..4 Selects the input channel.
<n>	1..3 Selects the waveform. For each channel, up to three waveforms can be analyzed. If WAVEform<n> is omitted, waveform 1 is addressed.

Parameters:

<DecimationMode> SAMPLE | PDETECT | HRESOLUTION | RMS

SAMPLE

One of n samples in a sample interval of the ADC is recorded as waveform point.

PDETECT

Peak Detect: the minimum and the maximum of n samples in a sample interval are recorded as waveform points.

HRESOLUTION

High resolution: The average of n sample points is recorded as waveform point.

RMS

The waveform point is the root mean square of n sample values.

*RST: SAMPLE

CHANnel<m>[:WAVEform<n>]:ARITHmatics <TrArith>

Selects the method to build the resulting waveform from several consecutive acquisitions of the signal.

See also: "[Wfm Arithmetic](#)" on page 112.

Suffix:

<m>	1..4 Selects the input channel.
<n>	1..3 Selects the waveform. For each channel, up to three waveforms can be analyzed. If WAVEform<n> is omitted, waveform 1 is addressed.

Parameters:

<TrArith>	OFF ENVELOpe AVERAge
	OFF The data of the current acquisition is recorded according to the decimation settings.
	ENVELOpe Detects the minimum and maximum values in a sample interval over a number of acquisitions. To define the reset method, use ...
	AVERAge Calculates the average from the data of the current acquisition and a number of acquisitions before. To define the number of acquisitions, use ACQUIRE:COUNT .
*RST:	OFF

ACQUIRE:COUNT <MaxAcqCount>

The acquisition and average count has a double effect:

- it sets the number of waveforms acquired with [RUNSingle](#).
- it defines the number of waveforms used to calculate the average waveform, and

Parameters:

<MaxAcqCount>	Range: 1 to 16777215
	Increment: 10
*RST:	1

ACQUIRE:ARESet:IMMediate

Forces the immediate restart of the envelope and average calculation for all waveforms.

Usage: Event

Firmware/Software: V 1.36

ACquire:ARESet:MODE <ArithRst>

Defines when the envelope and average evaluation restarts.

Parameters:

<ArithRst> NONE | TIME | WFMS

TIME

Restarts the envelope and average calculation after the time defined with [ACquire:ARESet:TIME](#).

WFMS

Restarts the envelope and average calculation after a number of acquired waveforms defined with [ACquire:ARESet:WFMCOUNT](#).

*RST: NONE

Firmware/Software: V 1.36

ACquire:ARESet:TIME <EnvelopeTimeout>

Defines the time after which the envelope and average evaluation restarts.

The setting is relevant if [ACquire:ARESet:MODE](#) is set to TIME.

Parameters:

<EnvelopeTimeout> Range: 0.1 to 10000
Increment: 0.01
*RST: 0.1
Default unit: s

Firmware/Software: V 1.36

ACquire:ARESet:WFMCOUNT <MaxAcqCount>

Defines the number of acquired waveforms after which the envelope and average evaluation restarts.

The setting is relevant if [ACquire:ARESet:MODE](#) is set to WFMS.

Parameters:

<MaxAcqCount> Range: 1 to 16777215
Increment: 10
*RST: 1

Firmware/Software: V 1.36

ACquire:SEGmented:STATe <State>

Switches the Ultra Segmentation mode on and off.

See also: [chapter 3.3.1.4, "Ultra Segmentation"](#), on page 113.

Parameters:

<State> ON | OFF
 *RST: OFF

ACQUIRE:SEGMENTED:MAX <MaxAcquisitions>

The number of acquisitions in a Ultra Segmentation acquisition series depends on the record length.

Parameters:

<MaxAcquisitions> ON | OFF
ON
 The maximum possible number of acquisitions in a series is used.
OFF
 Acquires the number of acquisitions defined using [ACQUIRE:COUNT](#).
 *RST: OFF

ACQUIRE:SEGMENTED:AUTOREPLAY <EnabReplayAfterAcq>

If enabled, the instrument starts processing and displaying the data as soon as the acquisition series is captured completely. Depending on the number of acquisitions, it may take some time until the acquisition series is displayed. If the setting is disabled, the instrument only captures the data and stores it in the sample memory.

Parameters:

<ReplayAfterAcq> ON | OFF
 *RST: ON

Firmware/Software: FW 1.40

21.2.6.4 Vertical

CHANnel<m>:STATE	685
CHANnel<m>:COUPling	686
CHANnel<m>:GND	686
CHANnel<m>:SCALE	686
CHANnel<m>:RANGe	687
CHANnel<m>:POSition	687
CHANnel<m>:OFFSet	688
CHANnel<m>:BANDwidth	688
CHANnel<m>:IMPedance	688
CHANnel<m>:OVERload	689

CHANnel<m>:STATE <State>

Switches the channel signal on or off.

Suffix:

<m> 1..4
Selects the input channel.

Parameters:

<State> ON | OFF
*RST: OFF

CHANnel<m>:COUPling <Coupling>

Selects the connection of the indicated channel signal.

Suffix:

<m> 1..4
Selects the input channel.

Parameters:

<Coupling> DC | DCLimit | AC
DC
Direct connection with 50 Ω termination.
DCLimit
Direct connection with 1 M Ω termination.
AC
Connection through DC capacitor.
*RST: DCLimit

CHANnel<m>:GND <State>

Connects the signal to the ground.

Suffix:

<m> 1..4

Parameters:

<State> ON | OFF
*RST: OFF

CHANnel<m>:SCALe <Scale>

Sets the vertical scale for the indicated channel.

Suffix:

<m> 1..4
Selects the input channel.

Parameters:

<Scale>	Scale value, given in Volts per division.
Range:	Depends on attenuation factors and coupling. With 1:1 probe and external attenuations and 50 Ω input coupling, the vertical scale (input sensitivity) is 1 mV/div to 1 V/div. For 1 M Ω input coupling, it is 1 mV/div to 10 V/div. If the probe and/or external attenuation is changed, multiply the values by the attenuation factors to get the actual scale range.
Increment:	1E-3
*RST:	0.05
Default unit:	V/div

CHANnel<m>:RANGe <Range>

Sets the voltage range across the 10 vertical divisions of the diagram. Use the command alternatively instead of [CHANnel<m>:SCALE](#).

Suffix:

<m>	1..4
	Selects the input channel.

Parameters:

<Range>	Voltage range value
Range:	Depends on attenuation factors and coupling. With 1:1 probe and external attenuations and 50 Ω input coupling, the range is 10 mV to 10 V. For 1 M Ω input coupling, it is 10 mV to 100 V. If the probe and/or external attenuation is changed, multiply the range values by the attenuation factors.
Increment:	0.01
*RST:	0.5
Default unit:	V/div

CHANnel<m>:POSition <Position>

Sets the vertical position of the indicated channel as a graphical value.

Suffix:

<m>	1..4
	Selects the input channel.

Parameters:

<Position>	Positive values move the waveform up, negative values move it down.
Range:	-5 to 5
Increment:	0.02
*RST:	0
Default unit:	div

CHANnel<m>:OFFSet <Offset>

The offset voltage is subtracted to correct an offset-affected signal. The offset of a signal is determined and set by the autoset procedure.

See also: "[Offset](#)" on page 117

Suffix:

<m> 1..4
Selects the input channel.

Parameters:

<Offset> Negative values move the waveform up, positive values move it down.
Range: Depends on attenuation factors, input coupling, and the offset compensation range of active probes. The nominal offset range for 1:1 attenuation and probe offset compensation = 0 is specified in the data sheet.
Increment: 0.01
*RST: 0
Default unit: V

CHANnel<m>:BANDwidth <BandwidthLimit>

Selects the bandwidth limit for the indicated channel.

Suffix:

<m> 1..4
Selects the input channel.

Parameters:

<BandwidthLimit> FULL | B800 | B200 | B20
FULL
Use full bandwidth.
B800
Limit to 800 MHz. Available for 50 Ω coupling. The value is only relevant if the instrument's bandwidth is > 800 MHz.
B200
Limit to 200 MHz.
B20
Limit to 20 MHz.
*RST: FULL

CHANnel<m>:IMPedance <Impedance>

Sets the impedance of the channel for power calculations and measurements.

Suffix:

<m> 1..4
Selects the input channel.

Parameters:

<Impedance> Range: 1 to 100E+3
Increment: 1
*RST: 50
Default unit: Ohm

CHANnel<m>:OVERload <Overload>

Retrieves the overload status of the specified channel from the status bit. When the overload problem is solved, the command resets the status bit.

Suffix:

<m> 1..4
Selects the input channel.

Parameters:

<Overload> ON | OFF
Use OFF to reset the overload status bit.
*RST: OFF

Example:

CHANnel12:OVERload?
Queries the overload status of channel 2.
CHANnel12:OVERload OFF
Resets the overload status bit.

21.2.6.5 Waveform Data

To set the export data format, see [FORMat \[: DATA \]](#) on page 673.

CHANnel<m>[:WAVEform<n>]:DATA:HEADER?..... 689
CHANnel<m>[:WAVEform<n>]:DATA[:VALUES]?..... 690

CHANnel<m>[:WAVEform<n>]:DATA:HEADER?

Returns the header of channel waveform data.

Table 21-12: Header data

Position	Meaning	Example
1	XStart in s	-9.477E-008 = - 94,77 ns
2	XStop in s	9.477E-008 = 94,77 ns
3	Record length of the waveform in Samples	200000
4	Number of values per sample interval. For most waveforms the result is 1, for peak detect and envelope waveforms it is 2. If the number is 2, the number of returned values is twice the number of samples (record length).	1

Suffix:	
<m>	1..4 Selects the input channel.
<n>	1..3 Selects the waveform. If [WAVEform<n>] is omitted, waveform 1 is addressed.
Example:	CHAN1:WAV1:DATA:HEAD? -9.477E-008,9.477E-008,200000,1
Usage:	Query only SCPI confirmed

CHANnel<m>[:WAVEform<n>]:DATA[:VALues]?

Returns the data of the channel waveform points for transmission from the instrument to the controlling computer. The data can be used in MATLAB, for example.

To set the export format, use [FORMat\[:DATA\]](#).

You can retrieve only Y-values (usually voltage values), or X- and Y-values. Use [EXPort:WAVEform:INCXvalues](#) to define this.

Suffix:	
<m>	1..4 Selects the input channel.
<n>	1..3 Selects the waveform. If [WAVEform<n>] is omitted, waveform 1 is addressed.
Return values:	
<Data>	List of values according to the format and content settings.
Example:	FORM ASC EXP:WAV:INCX OFF CHAN1:WAV1:DATA? -0.125000,-0.123016,-0.123016,-0.123016, -0.123016,-0.123016,...
Usage:	Query only

21.2.6.6 Probes

PROBe<m>:SETup:STATe?	691
PROBe<m>:SETup:ATTenuation:MODE	691
PROBe<m>:SETup:ATTenuation[:AUTO]?	691
PROBe<m>:SETup:ATTenuation:DEFProbe	692
PROBe<m>:SETup:ATTenuation:UNIT	692
PROBe<m>:SETup:ATTenuation:MANual	693
PROBe<m>:SETup:GAIN:AUTO?	693
PROBe<m>:SETup:GAIN:MANual	693
CHANnel<m>:EATScale	693

CHANnel<m>:EATTenuation.....	694
PROBe<m>:SETup:ZA15.....	694
PROBe<m>:SETup:OFFSet:AZERo.....	694
PROBe<m>:SETup:OFFSet:TOMean.....	695
PROBe<m>:SETup:CMOFFset.....	695
PROBe<m>:SETup:MODE.....	695
PROBe<m>:SETup:TYPE?.....	696
PROBe<m>:SETup:NAME?.....	696
PROBe<m>:SETup:IMPedance?.....	697
PROBe<m>:SETup:CAPacitance?.....	697
PROBe<m>:SETup:BANDwidth?.....	697
PROBe<m>:SETup:DISPlaydiff.....	698
PROBe<m>:ID:SWVersion?.....	698
PROBe<m>:ID:PRDate?.....	698
PROBe<m>:ID:PARTnumber?.....	698
PROBe<m>:ID:SRNumber?.....	699

PROBe<m>:SETup:STATe?

Queries if the probe at the specified input channel is active (detected) or not active (not detected). To switch the probe on, use [CHANnel<m>:STATe](#).

Suffix:

<m> 1..4

Return values:

<State> DETected | NDETECTED
*RST: NDETECTED

Usage: Query only

PROBe<m>:SETup:ATTenuation:MODE <ProbeAttMode>

Set the mode to MANual if the instrument does not detect the probe.

Suffix:

<m> 1..4
Selects the input channel.

Parameters:

<ProbeAttMode> AUTO | MANual
*RST: AUTO

PROBe<m>:SETup:ATTenuation[:AUTO]?

Queries the attenuation of the probe.

Suffix:

<m> 1..4
Selects the input channel.

Return values:

<ProbeAttModeAuto> Range: 1E-3 to 1000
 *RST: 1
 Default unit: V/V

Usage: Query only

PROBe<m>:SETup:ATTenuation:DEFProbe <PredefinedProbe>

Selects a predefined probe. These are probes that are not recognized automatically but the parameters of the probe are known to the instrument.

Suffix:

<m> 1..4
 Selects the input channel.

Parameters:

<PredefinedProbe> ZC10 | ZC20 | ZD01A100 | ZD01A1000 | ZZ80 | FREE

ZC10 | ZC20

Current probe R&S RT-ZC10 or R&S RT-ZC20

ZD01A100 | ZD01A1000

High voltage differential probe R&S RT-ZD01, attenuation ratio 100:1 or 1000:1 according to the setting on the probe control box

ZZ80

Transmission line passive probe R&S RT-ZZ80

FREE

Any other probe that is not recognized by the instrument.

*RST: FREE

Firmware/Software: V 1.27

PROBe<m>:SETup:ATTenuation:UNIT <ProbeAttUnit>

Sets the unit for the connected probe type if [PROBe<m>:SETup:ATTenuation:MODE](#) on page 691 is set to `MANual`.

Suffix:

<m> 1..4
 Selects the input channel.

Parameters:

<ProbeAttUnit> V | A | W
 Voltage probe (V), current probe (A), power probe (W)
 *RST: V

PROBe<m>:SETup:ATTenuation:MANual <AttManual>

Sets the attenuation for the connected probe if `PROBe<m>:SETup:ATTenuation:MODE` on page 691 is set to `MANual`.

Suffix:

<m> 1..4
Selects the input channel.

Parameters:

<AttManual> Range: 100E-6 to 10000
Increment: 0.1
*RST: 10
Default unit: depends on the selected unit

PROBe<m>:SETup:GAIN:AUTO?

Returns the gain of an automatically detected current probe.

Suffix:

<m> 1..4
Selects the input channel. The number of channels depends on the instrument.

Return values:

<GainAuto> Range: 1E-3 to 1000
*RST: 1
Default unit: V/A

Usage: Query only

PROBe<m>:SETup:GAIN:MANual <GainManual>

Sets the gain of a current probe.

Suffix:

<m> 1..4
Selects the input channel. The number of channels depends on the instrument.

Parameters:

<GainManual> Range: 100E-6 to 10000
Increment: 100E-6
*RST: 0.1
Default unit: V/A

CHANnel<m>:EATScale <ExtAttScale>

Sets the attenuation scale for an external divider.

Suffix:

<m> 1..4
Selects the input channel.

Parameters:

<ExtAttScale> LIN | LOG
*RST: LIN

CHANnel<m>:EATTenuation <ExtAtt>

Sets the attenuation of an external voltage divider that is part of the DUT before the measuring point. The external attenuation is included in the measurement, and the instrument shows the results that would be measured before the divider.

Suffix:

<m> 1..4
Selects the input channel.

Parameters:

<ExtAtt> Values and unit depend on the selected scale ([CHANnel<m>:EATScale](#)).

Range: Linear scale: 1E-3 to 1E+6, logarithmic scale: -60 dB to 120 dB
Increment: 0.01
*RST: 1

PROBe<m>:SETup:ZA15 <Enable>

If you use the external attenuator R&S RT-ZA15 together with one of the differential active probes R&S RT-ZD10/20/30, enable RT-ZA15 to include the external attenuation in the measurements.

Suffix:

<m> 1..4
Selects the input channel.

Parameters:

<Enable> ON | OFF
*RST: OFF

PROBe<m>:SETup:OFFSet:AZERo

Performs an automatic correction of the zero error. If the DUT is ground-referenced, the AutoZero function can improve the measurement results.

See also: "[Detect AutoZero, Use AutoZero](#)" on page 125

Suffix:

<m> 1..4
Selects the input channel.

Usage: Event

PROBe<m>:SETup:OFFSet:TOMean

Performs an automatic compensation for a DC component of the specified input signal using the result of a background mean measurement.

Suffix:

<m> 1..4
Selects the input channel.

Usage: Event

PROBe<m>:SETup:CMOffset <CMOffset>

Sets the common-mode offset. The setting is only available for differential probes.

Suffix:

<m> 1..4
Selects the input channel.

Parameters:

<CMOffset> Range: -100E+24 to 100E+24
Increment: 1E-3
*RST: 0
Default unit: V

PROBe<m>:SETup:MODE <Mode>

Select the action that is started with the micro button on the probe head.

See also: "[Micro button action](#)" on page 125.

Suffix:

<m> 1..4
Selects the input channel.

Parameters:

<Mode> RCONtinuous | RSINgle | AUToset | AZERo | SEToffsettomean | PRINT | SITFile | NOACtion

RCONtinuous

Run continuous: The acquisition is running as long as the probe button is pressed.

RSINgle

Run single: starts one acquisition.

AUTOSET

Starts the autotest procedure.

AZero

AutoZero: performs an automatic correction of the zero error.

SEToffsettomean

Set offset to mean: performs an automatic compensation for a DC component of the input signal.

PRINT

Prints the current display according to the printer set with `SYSTEM:COMMunicate:PRINter:SElect<1..2>`.

SITFile

Save Image To File:

Directs the display image to a file. The `MMEMory:NAME` command defines the file name. The file format is defined with `HCOPY:DEVice<m>:LANGuage`.

NOACtion

Nothing is started on pressing the micro button.

*RST: RCONtinuous

PROBe<m>:SETup:TYPE?

Queries the type of the probe.

Suffix:

<m> 1..4
Selects the input channel.

Return values:

<Type> String containing one of the following values:
– None (no probe detected)
– Passive Probe
– active single-ended

Usage: Query only

PROBe<m>:SETup:NAME?

Queries the name of the probe.

Suffix:
 <m> 1..4
 Selects the input channel.

Return values:
 <Name> Name string

Usage: Query only

PROBe<m>:SETup:IMPedance?

Queries the termination of the probe.

Suffix:
 <m> 1..4
 Selects the input channel.

Return values:
 <InputImpedance> Range: 100E-15 to 1E+9
 *RST: 50
 Default unit: Ω

Usage: Query only

PROBe<m>:SETup:CAPacitance?

Queries the input capacitance of the probe.

Suffix:
 <m> 1..4
 Selects the input channel.

Return values:
 <InputCapacity> Range: 100E-15 to 1E-9
 *RST: 10E-12
 Default unit: F

Usage: Query only

PROBe<m>:SETup:BANDwidth?

Queries the bandwidth of the probe.

Suffix:
 <m> 1..4
 Selects the input channel.

Return values:
 <Bandwidth> Range: 1E+6 to 20E+9
 *RST: 1E+9
 Default unit: Hz

Usage: Query only

PROBe<m>:SETup:DISPlaydiff <DisplayDiff>

Selects the input voltages to be measured by the ProbeMeter of an R&S differential active probe.

See also: "[Differential active probes](#)" on page 100.

Suffix:

<m> 1..4
Selects the input channel.

Parameters:

<DisplayDiff> DIFFerential | SINGleended
DIFFerential
Measures differential and common mode voltages
SINGleended
Measures the voltage between the positive/negative signal socket and the ground.
 *RST: DIFFerential

PROBe<m>:ID:SWVersion?

Queries the version of the probe firmware.

Suffix:

<m> 1..4
Selects the input channel.

Return values:

<Softwareversion> Version number in a string.

Usage: Query only

PROBe<m>:ID:PRDate?

Queries the production date of the probe.

Suffix:

<m> 1..4
Selects the input channel.

Return values:

<ProductionDate> Date in a string.

Usage: Query only

PROBe<m>:ID:PARTnumber?

Queries the R&S part number of the probe.

Suffix:

<m> 1..4
Selects the input channel.

Return values:

<PartNumber> Part number in a string.

Usage: Query only

PROBe<m>:ID:SRNumber?

Queries the serial number of the probe.

Suffix:

<m> 1..4
Selects the input channel.

Return values:

<SerialNo> Serial number in a string.

Usage: Query only

21.2.6.7 Digital Filter

CHANnel<m>:DIGFilter:STATe.....	699
CHANnel<m>:DIGFilter:CUToff.....	699
TRIGger<m>:COUPling.....	700
TRIGger<m>:RFReject<n>.....	700

CHANnel<m>:DIGFilter:STATe <State>

Enables the DSP filter.

Suffix:

<m> 1..4
Selects the input channel.

Parameters:

<State> ON | OFF
*RST: OFF

CHANnel<m>:DIGFilter:CUToff <CutOffLP>

Sets the limit frequency of the Lowpass filter for input channels.

The filter value is applied to two channels in R&S RTO1022 and R&S RTO1024, or applied to all available channels in R&S RTO1012 and R&S RTO1014.

Suffix:

<m> 1..4
Selects the input channel.

Parameters:

<CutOffLP> Range: 100E+3 to 4E+9
Increment: 1000
*RST: 1E+6
Default unit: Hz

TRIGger<m>:COUPling <DigitalTrigCoup>

Selects the filter for the trigger channel(s). Other channels must use the same filter, or proceed unfiltered.

Suffix:

<m> 1..3

Parameters:

<DigitalTrigCoup> OFF | RFReject

OFF

The trigger signal is not filtered.

RFReject

Frequencies higher a given limit are rejected, lower frequencies pass the filter. The limit is set with [TRIGger<m>:RFReject<n>](#)

.

*RST: OFF

TRIGger<m>:RFReject<n> <RejectBandwidth>

Sets the limit frequency, if the trigger coupling is set to RFReject. See [TRIGger<m>:COUPling](#).

Suffix:

<m> 1..3
Event in a trigger sequence: 1 = A-event, 2 = B-event, 3 = R-event.

Parameters:

<RejectBandwidth> Range: 100E+3 to 4E+9
Increment: 1000
*RST: 1E+6
Default unit: Hz

21.2.6.8 Skew

[CHANnel<m>:SKEW:MANual](#)..... 700
[CHANnel<m>:SKEW:TIME](#)..... 701

CHANnel<m>:SKEW:MANual <ManualCompensation>

If enabled, the skew offset value ([CHANnel<m>:SKEW:TIME](#)) is used for compensation. This improves horizontal and trigger accuracy.

Suffix:

<m> 1..4
Selects the input channel.

Parameters:

<ManualCompensation> ON | OFF
*RST: ON

CHANnel<m>:SKEW:TIME <Offset>

Sets an delay value, that is known from the circuit specifics but cannot be compensated by the instrument automatically. It affects only the selected input channel.

Suffix:

<m> 1..4
Selects the input channel.

Parameters:

<Offset> Range: -100E-9 to 100E-9
Increment: 1E-12
*RST: 0
Default unit: s

21.2.6.9 Reference (OCXO Option R&S RTO)-B4

[SENSe\[:ROSCillator\]:SOURce](#)..... 701

[SENSe\[:ROSCillator\]:EXTernal:FREQUENCY](#)..... 701

SENSe[:ROSCillator]:SOURce <RefOscillatorSrc>

Enables the use of the external reference signal instead of the internal OCXO reference.

Parameters:

<RefOscillatorSrc> INTernal | EXTernal
*RST: INTernal

SENSe[:ROSCillator]:EXTernal:FREQUENCY <ExternalRef>

Sets the frequency of an external reference input signal that is connected to the external reference input on the rear panel.

Parameters:

<ExternalRef> Range: 1E+6 to 20E+6
Increment: 1E+6
*RST: 10E+6
Default unit: Hz

21.2.7 Trigger

- [Basic Trigger Settings](#)..... 702
- [Edge Trigger](#)..... 706
- [Glitch Trigger](#)..... 709
- [Width Trigger](#)..... 710
- [Runt Trigger](#)..... 712
- [Window Trigger](#)..... 714
- [Timeout Trigger](#)..... 717
- [Interval Trigger](#)..... 717

• Slew Rate Trigger.....	719
• Data2Clock Trigger.....	722
• State Trigger.....	723
• Pattern Trigger.....	724
• Serial Pattern Trigger.....	727
• TV/Video Trigger.....	728
• Trigger Qualification.....	733
• Noise Reject.....	736
• Trigger Sequence.....	738
• Horizontal Position.....	744
• Trigger Control.....	745

21.2.7.1 Basic Trigger Settings

DISPlay:TRIGger:LINes.....	702
TRIGger<m>:SOURce.....	702
TRIGger<m>:TYPE.....	703
TRIGger<m>:LEVel<n>[:VALue].....	704
TRIGger<m>:FINDlevel.....	705
TRIGger<m>:ROBust.....	705
TRIGger<m>:ECOupling.....	706
TRIGger<m>:SCOupling.....	706

DISPlay:TRIGger:LINes <State>

Hides or shows the trigger levels in the diagrams.

Parameters:

<State> ON | OFF
 *RST: OFF

TRIGger<m>:SOURce <SourceDetailed>

Selects the source of the trigger signal.

Suffix:

<m> 1..3
 Event in a trigger sequence: 1 = A-event, 2 = B-event, 3 = R-event.
 Available values depend on the selected trigger source. For input channels CHAN1...4, a trigger sequence can be configured, and suffix values 1, 2, and 3 are allowed.
 For all other trigger sources, only suffix 1 is allowed.
 See also: [TRIGger<m>:SEquence:MODE](#)

Parameters:

<SourceDetailed>	CHAN1 CHAN2 CHAN3 CHAN4 EXTErnalog SBUS D0 D1 D2 D3 D4 D5 D6 D7 D8 D9 D10 D11 D12 D13 D14 D15 LOGIC MSOB1 MSOB2 MSOB3 MSOB4
	CHAN1...CHAN4 Input channels
	EXTErnalog External analog signal connected to the External Trigger Input on the rear panel. For this source, only the analog edge trigger is available.
	SBUS Serial bus
	D0...D15 Digital channels (option R&S RTO-B1) See also: chapter 21.2.18.3, "Trigger Settings for Digital Signals and Parallel Buses" , on page 1058
	LOGic Logic combination of digital channels, used as trigger source (option R&S RTO-B1)
	MSOB1 MSOB2 MSOB3 MSOB4 Parallel bus (option R&S RTO-B1)
	*RST: CHAN1

TRIGger<m>:TYPE <Type>

Selects the trigger type to trigger on analog channels or the external trigger input.

See also: [chapter 4.3.1, "Events and Trigger Types"](#), on page 138.

To trigger on digital channels and parallel buses, use **TRIGger<m>:PARAllel:TYPE**.

Suffix:

<m>	1..3
	Indicates the event in a trigger sequence: 1 = A-event, 2 = B-event, 3 = R-event.

Parameters:

<Type>

EDGE | GLITCh | WIDTH | RUNT | WINDOW | TIMEout |
INTERval | SLEWrate | DATatoclock | STATE | PATtern |
ANEDge | SERPattern | NFC | TV | CDR

Most of the type values are self-explanatory.

DATatoclockData2Clock: analyzes the relative timing between a data signal and the synchronous clock signal. For trigger settings, see [chapter 21.2.7.10, "Data2Clock Trigger"](#), on page 722.**ANEDge**Analog edge trigger: only available if the trigger source is the EXT TRIGGER INPUT on the rear panel. The analog edge trigger uses the analog input signal. For trigger settings, see [chapter 21.2.7.2, "Edge Trigger"](#), on page 706.See also: "[External trigger input, analog and digital trigger system](#)" on page 134**SERPattern**Serial Pattern for signals with serial data patterns in relation to a clock signal. For trigger settings, see [chapter 21.2.7.13, "Serial Pattern Trigger"](#), on page 727**NFC**Specific trigger for Near Field Communication testing, requires option R&S RTO-K11. For NFC trigger settings, see [chapter 21.2.19.3, "NFC Trigger"](#), on page 1074.**TV**Video trigger. For TV trigger settings, see [chapter 21.2.7.14, "TV/Video Trigger"](#), on page 728.**CDR**Trigger on the edges of a recovered clock signal, requires option R&S RTO-K13. For CDR trigger settings, see [chapter 17.2.2.2, "CDR Trigger"](#), on page 556.

*RST: EDGE

TRIGger<m>:LEVel<n>[:VALue] <Level>

Sets the trigger level for the specified event and source.

If the trigger source is serial bus, the trigger level is set by the thresholds in the protocol configuration.

The clock data recovery module (CDR option R&S RTO-K13) uses the trigger level also as threshold to detect signal edges. In this case, m = 1 and n = 1 | 2 | 3 | 4.

Suffix:

<m>

1..3

Indicates the event in a trigger sequence: 1 = A-event, 2 = B-event, 3 = R-event.

<n> 1..9
 Indicates the trigger source:
 1...4 = channel 1 to 4, available for all events m = 1 ..3
 5 = External Trigger Input on the rear panel for analog signals,
 available for A-event, m = 1
 6...9 = not available

Parameters:

<Level> Voltage for the trigger level.
 Range: -10 to 10
 Increment: 1E-3
 *RST: 0
 Default unit: V

Example:

```
TRIG:LEV5 0.01
```

Sets the trigger level for the external trigger signal to 10 mV.

```
TRIG2:LEV3 0.2
```

Sets the trigger level for the B-event and B-trigger source channel 3 to 200 mV.

TRIGger<m>:FINDlevel

Sets the trigger level automatically. The command is not available for an external trigger source.

Suffix:

<m> 1..3
 Indicates the event in a trigger sequence: 1 = A-event, 2 = B-event, 3 = R-event.

Usage:

Event
 Asynchronous command

TRIGger<m>:ROBust <Robust>

The "robust trigger" setting is relevant for all trigger types with an event condition that is based on the time difference between a rising and a falling edge. These trigger types are: glitch, width, runt, timeout, window, data2clock, pattern, and serial pattern. It avoids an undefined state of the trigger system that might occur due to hysteresis, for example, when triggering on the envelope of a modulated signal.

See also: "[Robust trigger](#)" on page 141

Suffix:

<m> 1..3
 Event in a trigger sequence: 1 = A-event, 2 = B-event, 3 = R-event.

Parameters:

<Robust> ON | OFF
 *RST: OFF

TRIGger<m>:ECOupling <TrigLevEvtCoup>

Sets the trigger levels of the channels to the values of the indicated event.

Suffix:

<m> 1..3
Indicates the event in a trigger sequence: 1 = A-event, 2 = B-event, 3 = R-event (reset event).

Parameters:

<TrigLevEvtCoup> ON | OFF
*RST: ON

TRIGger<m>:SCOupling <TrigLevSrcCoup>

Sets the trigger levels of all channels to the value of channel 1 for the indicated trigger event.

Suffix:

<m> 1..3
Indicates the trigger event in a trigger sequence: 1 = A-event, 2 = B-event, 3 = R-event (reset event).

Parameters:

<TrigLevSrcCoup> ON | OFF
*RST: OFF

21.2.7.2 Edge Trigger

TRIGger<m>:EDGE:SLOPe.....	706
TRIGger<m>:ANEDge:COUPling.....	707
TRIGger<m>:ANEDge:CUToff:HIGHPass.....	707
TRIGger<m>:ANEDge:CUToff:LOWPass.....	707
TRIGger<m>:ANEDge:FILTer.....	708
TRIGger<m>:ANEDge:GND.....	708
TRIGger<m>:ANEDge:SLOPe.....	709

TRIGger<m>:EDGE:SLOPe <Slope>

Defines the edge for the edge trigger event.

Suffix:

<m> 1..3
Event in a trigger sequence: 1 = A-event, 2 = B-event, 3 = R-event.

Parameters:

<Slope> POSitive | NEGative | EITHer
See [chapter 21.2.3.3, "Slope Parameter"](#), on page 666.
*RST: POSitive

TRIGger<m>:ANEDge:COUPling <Coupling>

Sets the coupling for the analog trigger signal.

Suffix:

<m> 1..3
Only suffix 1 = A-event is allowed, the analog edge trigger is not available for B- and R-events.

Parameters:

<Coupling> DC | DCLimit | AC
DC
Direct connection with 50 Ω termination, passes both DC and AC components of the trigger signal.
DCLimit
Direct connection with 1 MΩ termination, passes both DC and AC components of the trigger signal.
AC
Connection through DC capacitor, removes DC and very low-frequency components.
*RST: DCLimit

TRIGger<m>:ANEDge:CUToff:HIGHPass <AnalogCutOffHP>

Frequencies below the "Cut-off" frequency are rejected, higher frequencies pass the filter.

Suffix:

<m> 1..3
Only suffix 1 = A-event is allowed, the analog edge trigger is not available for B- and R-events.

Parameters:

<AnalogCutOffHP> KHZ5 | KHZ50 | MHZ50
Cut-off frequency
KHZ5
5 kHz
KHZ50
50 kHz
MHZ50
50 MHz
*RST: KHZ50

TRIGger<m>:ANEDge:CUToff:LOWPass <AnalogCutOffLP>

Frequencies higher than the "Cut-off" frequency are rejected, lower frequencies pass the filter.

Suffix:
 <m> 1..3
 Only suffix 1 = A-event is allowed, the analog edge trigger is not available for B- and R-events.

Parameters:
 <AnalogCutOffLP> KHZ5 | KHZ50 | MHZ50
KHZ5
 5 kHz
KHZ50
 50 kHz
MHZ50
 50 MHz
 *RST: KHZ50

TRIGger<m>:ANEDge:FILTer <Filter>

The analog trigger signal is used for triggering; you can directly select an additional filter to reject high or low frequencies.

Suffix:
 <m> 1..3
 Only suffix 1 = A-event is allowed, the analog edge trigger is not available for B- and R-events.

Parameters:
 <Filter> OFF | LFReject | RFReject
OFF
 The trigger signal is not filtered.
LFReject
 Frequencies higher than the "Cut-off" frequency are rejected, lower frequencies pass the filter.
 You can adjust the "Cut-off" frequency using the [TRIGger<m>:ANEDge:CUToff:LOWPass](#) command, the default is 50 kHz.
RFReject
 Frequencies below the "Cut-off" frequency are rejected, higher frequencies pass the filter.
 You can adjust the "Cut-off" frequency using the [TRIGger<m>:ANEDge:CUToff:HIGHPass](#) command, the default is 50 kHz.
 *RST: OFF

TRIGger<m>:ANEDge:GND <Ground>

Connects the analog signal to the ground.

Suffix:
 <m> 1..3
 Only suffix 1 = A-event is allowed, the analog edge trigger is not available for B- and R-events.

Parameters:

<Ground> ON | OFF
 *RST: OFF

TRIGger<m>:ANEDge:SLOPe <Slope>

Sets the edge for the trigger event.

Suffix:

<m> 1..3
 Only suffix 1 = A-event is allowed, the analog edge trigger is not available for B- and R-events.

Parameters:

<Slope> POSitive | NEGative
 See [chapter 21.2.3.3, "Slope Parameter"](#), on page 666.
 *RST: POSitive

21.2.7.3 Glitch Trigger

The glitch trigger is not available for the B-event (Suffix = 2).

TRIGger<m>:GLITch:POLarity	709
TRIGger<m>:GLITch:RANGe	709
TRIGger<m>:GLITch:WIDTh	710

TRIGger<m>:GLITch:POLarity <Polarity>

Defines the polarity of a pulse, that is the direction of the first pulse slope.

Suffix:

<m> 1..3
 Event in a trigger sequence: 1 = A-event, 3 = R-event.

Parameters:

<Polarity> POSitive | NEGative | EITHer
 See [chapter 21.2.3.4, "Polarity Parameter"](#), on page 667.
 *RST: POSitive

TRIGger<m>:GLITch:RANGe <RangeMode>

Selects which glitches are identified: shorter or longer than the width specified using [TRIGger<m>:GLITch:WIDTh](#).

Suffix:

<m> 1 | 3
 Event in a trigger sequence: 1 = A-event, 3 = R-event.

Parameters:

<RangeMode> SHORter | LONGer

SHORter

Glitches shorter than the specified width are identified.

LONGer

Glitches longer than the specified width are identified.

*RST: SHORter

TRIGger<m>:GLITCh:WIDTh <Width>

Sets the length of a glitch. The instrument triggers on pulses shorter or longer than this value, depending on the [TRIGger<m>:GLITCh:RANGe](#) command.

You need to know the expected pulse widths of the circuit to set the glitch width correctly.

Suffix:

<m> 1 | 3

Event in a trigger sequence: 1 = A-event, 3 = R-event.

Parameters:

<Width> Range: 100E-12 to 10000

Increment: 100E-6

*RST: 1E-9

Default unit: s

21.2.7.4 Width Trigger

The width trigger is not available for the B-event (Suffix = 2).

TRIGger<m>:WIDTh:POLarity	710
TRIGger<m>:WIDTh:RANGe	711
TRIGger<m>:WIDTh:WIDTh	711
TRIGger<m>:WIDTh:DELTA	711

TRIGger<m>:WIDTh:POLarity <Polarity>**Suffix:**

<m> 1..3

Event in a trigger sequence: 1 = A-event, 3 = R-event.

Parameters:

<Polarity> POSitive | NEGative

See [chapter 21.2.3.4, "Polarity Parameter"](#), on page 667.

*RST: POSitive

TRIGger<m>:WIDTh:RANGe <RangeMode>

Defines how the range of a pulse width is defined in relation to the width and delta specified using `TRIGger<m>:WIDTh:WIDTh` and `TRIGger<m>:WIDTh:DELTA`, respectively.

Suffix:

<m> 1 | 3
Event in a trigger sequence: 1 = A-event, 3 = R-event.

Parameters:

<RangeMode> WITHin | OUTSide | SHORter | LONGer

WITHin

Triggers on pulses inside a given range. The range is defined by the width \pm delta.

OUTSide

Triggers on pulses outside a given range. The range is defined by the width \pm delta.

SHORter

Triggers on pulses shorter than the given width.

LONGer

Triggers on pulses longer than the given width.

*RST: WITHin

TRIGger<m>:WIDTh:WIDTh <Width>

For the ranges "Within" and "Outside" (defined using `TRIGger<m>:WIDTh:RANGe`), the width defines the center of a range which is defined by the limits " \pm Delta" (see `TRIGger<m>:WIDTh:DELTA` on page 711).

For the ranges "Shorter" and "Longer", the width defines the maximum and minimum pulse width, respectively.

Suffix:

<m> 1 | 3
Event in a trigger sequence: 1 = A-event, 3 = R-event.

Parameters:

<Width> Range: 100E-12 to 10000
Increment: 100E-9
*RST: 5E-9
Default unit: s

TRIGger<m>:WIDTh:DELTA <WidthDelta>

Defines a range around the width value specified using `TRIGger<m>:WIDTh:WIDTh`.

Suffix:

<m> 1 | 3
Event in a trigger sequence: 1 = A-event, 3 = R-event.

Parameters:

<WidthDelta> Range: 0 to 432
 Increment: 500E-12
 *RST: 0
 Default unit: s

21.2.7.5 Runt Trigger

The runt trigger is not available for the B-event (Suffix = 2).

TRIGger<m>:RUNT:POLarity.....	712
TRIGger<m>:LEVel<n>:RUNT:UPPer.....	712
TRIGger<m>:LEVel<n>:RUNT:LOWer.....	712
TRIGger<m>:RUNT:RANGe.....	713
TRIGger<m>:RUNT:WIDTh.....	713
TRIGger<m>:RUNT:DELTA.....	714

TRIGger<m>:RUNT:POLarity <Polarity>**Suffix:**

<m> 1..3
 Event in a trigger sequence: 1 = A-event, 3 = R-event.

Parameters:

<Polarity> POSitive | NEGative | EITHer
 See [chapter 21.2.3.4, "Polarity Parameter"](#), on page 667.
 *RST: POSitive

TRIGger<m>:LEVel<n>:RUNT:UPPer <Level>

Sets the upper voltage threshold.

Suffix:

<m> 1 | 3
 Event in a trigger sequence: 1 = A-event, 3 = R-event.

<n> 1..9
 Indicates the trigger source:
 1...4 = channel 1...4
 5...9 = not available

Parameters:

<Level> Range: -10 to 10
 Increment: 1E-3
 *RST: 0.1
 Default unit: V

TRIGger<m>:LEVel<n>:RUNT:LOWer <Level>

Sets the lower voltage threshold.

Suffix:

<m> 1 | 3
Event in a trigger sequence: 1 = A-event, 3 = R-event.

<n> 1..9
Indicates the trigger source:
1...4 = channel 1...4
5...9 = not available

Parameters:

<Level> Range: -10 to 10
Increment: 1E-3
*RST: -0.1
Default unit: V

TRIGger<m>:RUNT:RANGe <Mode>

Defines the time limit of the runt pulse in relation to the [TRIGger<m>:RUNT:WIDTh](#) and [TRIGger<m>:RUNT:DELTA](#) settings.

Suffix:

<m> 1 | 3
Event in a trigger sequence: 1 = A-event, 3 = R-event.

Parameters:

<Mode> ANY | LONGer | SHORter | WITHin | OUTSide

ANY
Triggers on all runts fulfilling the level condition, without time limitation.

LONGer
Triggers on runts longer than the given "Runt width".

SHORter
Triggers on runts shorter than the given "Runt width".

WITHin
Triggers if the runt length is inside a given time range. The range is defined by "Runt width" and "±Delta".

OUTSide
Triggers if the runt length is outside a given time range. The range is defined by "Runt width" and "±Delta".

*RST: ANY

TRIGger<m>:RUNT:WIDTh <Width>

Defines the upper or lower voltage threshold. This command is not available if [TRIGger<m>:RUNT:RANGe](#) is set to "ANY".

Suffix:

<m> 1 | 3
Event in a trigger sequence: 1 = A-event, 3 = R-event.

Parameters:

<Width> Range: 100E-12 to 10000
 Increment: 100E-9
 *RST: 5E-9
 Default unit: s

TRIGger<m>:RUNT:DELTA <WidthDelta>

Defines a range around the runt width specified using `TRIGger<m>:RUNT:WIDTh`. This command is only available if `TRIGger<m>:RUNT:RANGe` is set to "WITHin" or "OUTSide".

Suffix:

<m> 1 | 3
 Event in a trigger sequence: 1 = A-event, 3 = R-event.

Parameters:

<WidthDelta> Range: 100E-12 to 864
 Increment: 100E-9
 *RST: 100E-12
 Default unit: s

21.2.7.6 Window Trigger

The window trigger is not available for the B-event (Suffix = 2).

<code>TRIGger<m>:LEVel<n>:WINDow:UPPer</code>	714
<code>TRIGger<m>:LEVel<n>:WINDow:LOWer</code>	715
<code>TRIGger<m>:WINDow:RANGe</code>	715
<code>TRIGger<m>:WINDow:TIME</code>	715
<code>TRIGger<m>:WINDow:WIDTh</code>	716
<code>TRIGger<m>:WINDow:DELTA</code>	716

TRIGger<m>:LEVel<n>:WINDow:UPPer <Level>

Sets the upper voltage limit for the window.

Suffix:

<m> 1 | 3
 Event in a trigger sequence: 1 = A-event, 3 = R-event.

<n> 1..9
 Indicates the trigger source:
 1...4 = channel 1...4
 5...9 = not available

Parameters:

<Level> Range: -10 to 10
 Increment: 1E-3
 *RST: 0.1
 Default unit: V

TRIGger<m>:LEVel<n>:WINDow:LOWer <Level>

Sets the lower voltage limit for the window.

Suffix:

<m>	1 3 Event in a trigger sequence: 1 = A-event, 3 = R-event.
<n>	1..9 Indicates the trigger source: 1...4 = channel 1...4 5...9 = not available

Parameters:

<Level>	Range: -10 to 10 Increment: 1E-3 *RST: -0.1 Default unit: V
---------	--

TRIGger<m>:WINDow:RANGe <RangeMode>

Defines the signal run in relation to the window:

Suffix:

<m>	1 3 Event in a trigger sequence: 1 = A-event, 3 = R-event.
-----	---

Parameters:

<RangeMode>	ENTer EXIT WITHin OUTSide ENTer Triggers when the signal crosses the upper or lower level and thus enters the window made up of these two levels. EXIT Triggers when the signal leaves the window. WITHin Triggers if the signal stays between the upper and lower level for a specified time. The time is defined using the TRIGger<m>:WINDow:TIME command. OUTSide Triggers if the signal stays above the upper level or below the lower level for a specified time. The time is defined using the TRIGger<m>:WINDow:TIME command. *RST: ENTer
-------------	---

TRIGger<m>:WINDow:TIME <TimeRangeMode>

Defines the limit of the window in relation to the time specified using [TRIGger<m>:WINDow:WIDTh](#) and [TRIGger<m>:WINDow:DELTA](#). Time conditioning is available for [TRIGger<m>:WINDow:RANGe](#) = "WITHin" and "OUTSide".

Suffix:

<m> 1 | 3
Event in a trigger sequence: 1 = A-event, 3 = R-event.

Parameters:

<TimeRangeMode> WITHin | OUTSide | SHORter | LONGer

WITHin

Triggers if the signal stays inside or outside the vertical window limits at least for the time *Width - Delta* and for *Width + Delta* at the most.

OUTSide

"Outside" is the opposite definition of "Within". The instrument triggers if the signal stays inside or outside the vertical window limits for a time shorter than *Width - Delta* or longer than *Width + Delta*.

SHORter

Triggers if the signal crosses vertical limits before the specified "Width" time is reached.

LONGer

Triggers if the signal crosses vertical limits before the specified "Width" time is reached.

*RST: WITHin

TRIGger<m>:WINDow:WIDTh <Width>

For the ranges "Within" and "Outside" (defined using [TRIGger<m>:WINDow:RANGe](#)), the width defines the center of a time range which is defined by the limits " \pm Delta" (see [TRIGger<m>:WINDow:DELTA](#) on page 716).

For the ranges "Shorter" and "Longer", it defines the maximum and minimum time lapse, respectively.

Suffix:

<m> 1 | 3
Event in a trigger sequence: 1 = A-event, 3 = R-event.

Parameters:

<Width> Range: 100E-12 to 10000
Increment: 100E-9
*RST: 5E-9
Default unit: s

TRIGger<m>:WINDow:DELTA <WidthDelta>

Defines a range around the "Width" value specified using [TRIGger<m>:WINDow:WIDTh](#).

Suffix:

<m> 1 | 3
Event in a trigger sequence: 1 = A-event, 3 = R-event.

Parameters:

<WidthDelta> Range: 0 to 432
 Increment: 500E-12
 *RST: 0
 Default unit: s

21.2.7.7 Timeout Trigger

The timeout trigger is not available for the B-event (Suffix = 2).

TRIGger<m>:TIMeout:RANGe.....717
 TRIGger<m>:TIMeout:TIME.....717

TRIGger<m>:TIMeout:RANGe <TimeoutMode>

Defines the relation of the signal level to the trigger level.

Suffix:

<m> 1 | 3
 Event in a trigger sequence: 1 = A-event, 3 = R-event.

Parameters:

<TimeoutMode> HIGH | LOW | EITHer

HIGH

The signal level stays above the trigger level.

LOW

The signal level stays below the trigger level.

EITHer

The signal level stays above or below the trigger level.

*RST: HIGH

TRIGger<m>:TIMeout:TIME <Time>

Defines the time limit for the timeout at which the instrument triggers.

Suffix:

<m> 1 | 3
 Event in a trigger sequence: 1 = A-event, 3 = R-event.

Parameters:

<Time> Range: 100E-12 to 10000
 Increment: 100E-9
 *RST: 100E-9
 Default unit: s

21.2.7.8 Interval Trigger

The interval trigger is not available for the B-event (Suffix = 2).

TRIGger<m>:INTerval:POLarity.....	718
TRIGger<m>:INTerval:RANGe.....	718
TRIGger<m>:INTerval:WIDTh.....	718
TRIGger<m>:INTerval:DELTA.....	719

TRIGger<m>:INTerval:POLarity <Polarity>

Indicates the polarity of a pulse, that is the direction of the first pulse slope.

Suffix:

<m> 1..3
Event in a trigger sequence: 1 = A-event, 3 = R-event.

Parameters:

<Polarity> POSitive | NEGative | EITHer
See [chapter 21.2.3.4, "Polarity Parameter"](#), on page 667.
*RST: POSitive

TRIGger<m>:INTerval:RANGe <RangeMode>

Defines the range of an interval in relation to the interval width specified using [TRIGger<m>:INTerval:WIDTh](#) and [TRIGger<m>:INTerval:DELTA](#).

Suffix:

<m> 1 | 3
Event in a trigger sequence: 1 = A-event, 3 = R-event.

Parameters:

<RangeMode> WITHin | OUTSide | SHORter | LONGer

WITHin
Triggers on pulses inside a given range. The range is defined by the interval width $\pm\delta$.

OUTSide
Triggers on pulses outside a given range. The range is defined by the interval width $\pm\delta$.

SHORter
Triggers on pulses shorter than the given interval width.

LONGer
Triggers on pulses longer than the given interval width.
*RST: OUTSide

TRIGger<m>:INTerval:WIDTh <Width>

Defines the time between two pulses.

Suffix:

<m> 1 | 3
Event in a trigger sequence: 1 = A-event, 3 = R-event.

Parameters:

<Width> Range: 100E-12 to 10000
 Increment: 100E-9
 *RST: 5E-9
 Default unit: s

TRIGger<m>:INTerval:DELTA <WidthDelta>

Defines a range around the "Interval width" value specified using [TRIGger<m>:INTerval:WIDTh](#) on page 718.

Suffix:

<m> 1 | 3
 Event in a trigger sequence: 1 = A-event, 3 = R-event.

Parameters:

<WidthDelta> Range: 0 to 10
 Increment: 100E-9
 *RST: 0
 Default unit: s

21.2.7.9 Slew Rate Trigger

The slew rate trigger is not available for the B-event (Suffix = 2).

TRIGger<m>:SLEW:SLOPe	719
TRIGger<m>:LEVel<n>:SLEW:UPPer	719
TRIGger<m>:LEVel<n>:SLEW:LOWer	720
TRIGger<m>:SLEW:RANGe	720
TRIGger<m>:SLEW:RATE	721
TRIGger<m>:SLEW:DELTA	721

TRIGger<m>:SLEW:SLOPe <Slope>

Selects the edge type for the trigger event.

Suffix:

<m> 1..3
 Event in a trigger sequence: 1 = A-event, 3 = R-event.

Parameters:

<Slope> POSitive | NEGative | EITHer
 See [chapter 21.2.3.3, "Slope Parameter"](#), on page 666.
 *RST: POSitive

TRIGger<m>:LEVel<n>:SLEW:UPPer <Level>

Defines the upper voltage threshold. When the signal crosses this level, the slew rate measurement starts or stops depending on the selected slope.

Suffix:

<m> 1 | 3
Event in a trigger sequence: 1 = A-event, 3 = R-event.

<n> 1..9
Indicates the trigger source:
1...4 = channel 1...4
5...9 = not available

Parameters:

<Level> Range: -10 to 10
Increment: 1E-3
*RST: 0.1
Default unit: V

TRIGger<m>:LEVel<n>:SLEW:LOWer <Level>

Defines the lower voltage threshold. When the signal crosses this level, the slew rate measurement starts or stops depending on the selected slope.

Suffix:

<m> 1 | 3
Event in a trigger sequence: 1 = A-event, 3 = R-event.

<n> 1..9
Indicates the trigger source:
1...4 = channel 1...4
5...9 = not available

Parameters:

<Level> Range: -10 to 10
Increment: 1E-3
*RST: -0.1
Default unit: V

TRIGger<m>:SLEW:RANGe <RangeMode>

Defines the time limit for the slew rate in relation to the upper or lower trigger level (see [TRIGger<m>:SLEW:RATE](#) on page 721 and [TRIGger<m>:SLEW:DELTA](#) on page 721). The time measurement starts when the signal crosses the first trigger level - the upper or lower level depending on the selected slope - and stops when the signal crosses the second level.

Suffix:

<m> 1 | 3
Event in a trigger sequence: 1 = A-event, 3 = R-event.

Parameters:

<RangeMode> INSRange | OUTRange | LTHan | GTHan

INSRange

Triggers on pulses inside a given range. The range is defined by the slew rate $\pm\delta$.

OUTRange

Triggers on pulses outside a given range. The range is defined by the slew rate $\pm\delta$.

LTHan

Triggers on pulses shorter than the given slew rate.

GTHan

Triggers on pulses longer than the given slew rate.

*RST: GTHan

TRIGger<m>:SLEW:RATE <Time>

For the ranges "Within" and "Outside", the slew rate defines the center of a range which is defined by the limits " $\pm\Delta$ ".

For the ranges "Shorter" and "Longer", the slew rate defines the maximum and minimum slew rate limits, respectively. When the signal crosses this level, the slew rate measurement starts or stops depending on the selected slope (see [TRIGger<m>:SLEW:SLOPe](#) on page 719).

Suffix:

<m> 1 | 3
Event in a trigger sequence: 1 = A-event, 3 = R-event.

Parameters:

<Time> Range: 100E-12 to 10000
Increment: 100E-9
*RST: 100E-12
Default unit: s

TRIGger<m>:SLEW:DELTA <TimeDelta>

Defines a time range around the slew rate specified using [TRIGger<m>:SLEW:RATE](#).

Suffix:

<m> 1 | 3
Event in a trigger sequence: 1 = A-event, 3 = R-event.

Parameters:

<TimeDelta> Range: 0 to 10
Increment: 100E-9
*RST: 0
Default unit: s

21.2.7.10 Data2Clock Trigger

The Data2Clock trigger is only available for the A-event (Suffix = 1).

TRIGger<m>:DATatoclock:CSOource[:VALue].....	722
TRIGger<m>:DATatoclock:CSOource:EDGE.....	722
TRIGger<m>:DATatoclock:CSOource:LEVel.....	722
TRIGger<m>:DATatoclock:HTIME.....	723
TRIGger<m>:DATatoclock:STIME.....	723

TRIGger<m>:DATatoclock:CSOource[:VALue] <ClockSource>

Selects the source of the clock signal.

Suffix:

<m> 1..3
 A-event only

Parameters:

<ClockSource> CHAN1 | CHAN2 | CHAN3 | CHAN4
 Input channel
*RST: CHAN1

TRIGger<m>:DATatoclock:CSOource:EDGE <ClockEdge>

Sets the edge of the clock signal to define the time reference point for the setup and hold time.

Suffix:

<m> 1
 A-event only

Parameters:

<ClockEdge> POSitive | NEGative | EITHer
 See [chapter 21.2.3.3, "Slope Parameter"](#), on page 666.
*RST: POSitive

TRIGger<m>:DATatoclock:CSOource:LEVel <ClockLevel>

Sets the voltage level for the clock signal. Both this command and [TRIGger<m>:DATatoclock:CSOource:EDGE](#) define the starting point for calculation of the setup and hold time.

Suffix:

<m> 1
 A-event only

Parameters:

<ClockLevel> Range: -10 to 10
 Increment: 1E-3
 *RST: 0
 Default unit: V

TRIGger<m>:DATatoclock:HTIME <HoldTime>

Sets the minimum time **after** the clock edge while the data signal must stay steady above or below the data level.

The hold time can be negative. In this case, the setup time is always positive. The setup/hold interval starts before the clock edge (setup time) and ends before the clock edge (hold time). If you change the negative hold time, the setup time is adjusted by the instrument.

Suffix:

<m> 1
 A-event only

Parameters:

<HoldTime> Range: -99.999E-9 to 100E-9
 Increment: 1E-9
 *RST: 0
 Default unit: s

TRIGger<m>:DATatoclock:STIME <SetupTime>

Sets the minimum time **before** the clock edge while the data signal must stay steady above or below the data level.

The setup time can be negative. In this case, the hold time is always positive. The setup/hold interval starts after the clock edge (setup time) and ends after the clock edge (hold time). If you change the negative setup time, the hold time is adjusted by the instrument.

Suffix:

<m> 1
 A-event only

Parameters:

<SetupTime> Range: -99.999E-9 to 100E-9
 Increment: 1E-9
 *RST: 0
 Default unit: s

21.2.7.11 State Trigger

The state trigger combines the edge trigger settings with trigger qualification. It is not available for the B-event (Suffix = 2).

Use the following commands:

- `TRIGger<m>:EDGE:SLOPe` on page 706
- `TRIGger<m>:LEVel<n>[:VALue]` on page 704
- `TRIGger<m>:SCOupling` on page 706
- `TRIGger<m>:QUALify<n>:A[:ENABle]` on page 734 ()
- `TRIGger<m>:QUALify<n>:A:LOGic` on page 735
- `TRIGger<m>:QUALify<n>:AB:LOGic` on page 736

The pattern commands are listed for channel 1, use the similar commands for channels 2, 3, and 4.

21.2.7.12 Pattern Trigger

The pattern trigger is only available for the A-event (Suffix = 1).

The pattern is defined using the commands:

- `TRIGger<m>:QUALify<n>:A[:ENABle]` on page 734 ()
- `TRIGger<m>:QUALify<n>:A:LOGic` on page 735
- `TRIGger<m>:QUALify<n>:AB:LOGic` on page 736

These are the commands for channel 1, use the similar commands for channels 2, 3, and 4.

<code>TRIGger<m>:PATtern:MODE</code>	724
<code>TRIGger<m>:PATtern:TIMEout:MODE</code>	725
<code>TRIGger<m>:PATtern:TIMEout[:TIME]</code>	725
<code>TRIGger<m>:PATtern:WIDTh:RANGe</code>	726
<code>TRIGger<m>:PATtern:WIDTh[:WIDTh]</code>	726
<code>TRIGger<m>:PATtern:WIDTh:DELta</code>	726

`TRIGger<m>:PATtern:MODE <Mode>`

Adds additional time limitation to the pattern definition.

Suffix:

`<m>` 1..3
 1 = A-event only

Parameters:

<Mode>

OFF | TIMEout | WIDTH

OFF

No time limitation. The event occurs if the pattern condition is fulfilled.

TIMEout

Defines how long the result of the pattern condition must be true or false. The duration of the timeout is defined using

`TRIGger<m>:PATTern:TIMEout[:TIME]`.

WIDTH

Defines a time range for keeping up the true result of the pattern condition. The range is defined using `TRIGger<m>:PATTern:`

`WIDTH:RANGe`.

*RST: OFF

TRIGger<m>:PATTern:TIMEout:MODE <TimeoutMode>

Defines the condition for the timeout.

Suffix:

<m>

1..3

1 = A-event only

Parameters:

<TimeoutMode>

HIGH | LOW

HIGH

The result stays high.

LOW

The result stays low.

*RST: HIGH

TRIGger<m>:PATTern:TIMEout[:TIME] <Time>

Defines how long the result of the pattern condition must be true or false.

Suffix:

<m>

1..3

1 = A-event only

Parameters:

<Time>

Range: 100E-12 to 10000

Increment: 100E-9

*RST: 100E-9

Default unit: s

TRIGger<m>:PATTern:WIDTh:RANGe <WidthRangeMode>

Defines how the range of a pulse width is defined for keeping up the true result of the pattern condition. The width and delta are specified using `TRIGger<m>:PATTern:WIDTh[:WIDTh]` and `TRIGger<m>:PATTern:WIDTh:DELTA`, respectively.

Suffix:

<m> 1..3
1 = A-event only

Parameters:

<WidthRangeMode> WITHin | OUTSide | SHORter | LONGer

WITHin

Triggers on pulses inside a given range. The range is defined by the width $\pm\delta$.

OUTSide

Triggers on pulses outside a given range. The range is defined by the width $\pm\delta$.

SHORter

Triggers on pulses shorter than the given width.

LONGer

Triggers on pulses longer than the given width.

*RST: WITHin

TRIGger<m>:PATTern:WIDTh[:WIDTh] <Width>

For the ranges "Within" and "Outside" (defined using `TRIGger<m>:PATTern:WIDTh:RANGe`), the width defines the center of a range which is defined by the limits " $\pm\Delta$ " (see `TRIGger<m>:PATTern:WIDTh:DELTA` on page 726).

For the ranges "Shorter" and "Longer", the width defines the maximum and minimum pulse width, respectively.

Suffix:

<m> 1..3
1 = A-event only

Parameters:

<Width> Range: 100E-12 to 10000
Increment: 100E-9
*RST: 5E-9
Default unit: s

TRIGger<m>:PATTern:WIDTh:DELTA <WidthDelta>

Defines a range around the width value specified using `TRIGger<m>:PATTern:WIDTh[:WIDTh]`.

Suffix:
 <m> 1..3
 1 = A-event only

Parameters:
 <WidthDelta> Range: 0 to 432
 Increment: 500E-12
 *RST: 0
 Default unit: s

21.2.7.13 Serial Pattern Trigger

The serial pattern trigger is only available for the A-event (Suffix = 1).

TRIGger<m>:SPATtern:CSOource:VALue]	727
TRIGger<m>:SPATtern:CSOource:EDGE	727
TRIGger<m>:SPATtern:CSOource:LEVel	727
TRIGger<m>:SPATtern:PATTern	728

TRIGger<m>:SPATtern:CSOource[:VALue] <ClockSource>

Defines the source of the clock signal.

Suffix:
 <m> 1..3
 A-event only

Parameters:
 <ClockSource> CHAN1 | CHAN2 | CHAN3 | CHAN4
 Input channel
 *RST: CHAN1

TRIGger<m>:SPATtern:CSOource:EDGE <ClockEdge>

Together with the clock level (see [TRIGger<m>:SPATtern:CSOource:LEVel](#) on page 727), the clock edge defines the point in time when the state of the data signal is checked.

Suffix:
 <m> 1
 A-event only

Parameters:
 <ClockEdge> POSitive | NEGative | EITHer
 See [chapter 21.2.3.3, "Slope Parameter"](#), on page 666.
 *RST: POSitive

TRIGger<m>:SPATtern:CSOource:LEVel <ClockLevel>

Defines the voltage level for the clock signal.

Suffix:

<m> 1
A-event only

Parameters:

<ClockLevel> Range: -10 to 10
Increment: 1E-3
*RST: 0
Default unit: V

TRIGger<m>:SPATtern:PATtern <Pattern>

The pattern contains the bits of the serial data to be found in the data stream. The maximum length of the pattern is 128 bit.

Suffix:

<m> 1
A-event only

Parameters:

<Pattern> Numeric or string pattern, see [chapter 21.2.3.6, "Bit Pattern Parameter"](#), on page 667. The string parameter accepts the bit value X (don't care).

21.2.7.14 TV/Video Trigger

The TV or video trigger requires a channel input as trigger source ([TRIGger<m>:SOURce](#)). It is only available for the A-event (Suffix = 1).

Make sure to set the trigger level - the threshold of the sync pulse - with [TRIGger<m>:LEVel<n>\[:VALue\]](#).

TRIGger<m>:TV:STANdard	728
TRIGger<m>:TV:MODE	729
TRIGger<m>:TV:POLarity	730
TRIGger<m>:TV:LINE	730
TRIGger<m>:TV:LFIeld	731
TRIGger<m>:TV:CUSTom:SCANmode	732
TRIGger<m>:TV:CUSTom:LDURation	732
TRIGger<m>:TV:CUSTom:STYPe	732
TRIGger<m>:TV:CUSTom:SDURation	733

TRIGger<m>:TV:STANdard <Standard>

Sets the TV standard.

Suffix:

<m> 1..3
Event in a trigger sequence: 1 = A-event only

Parameters:

<Standard>

CUSTom | PAL | PALM | NTSC | SECam | P480L60HZ |
 P720L30HZ | P720L50HZ | P720L60HZ | I1080L50HZ |
 I1080L60HZ | P1080L24HZ | P1080L24HZSF | P1080L25HZ |
 P1080L30HZ | P1080L50HZ | P1080L60HZ

CUSTom

User-defined signal. Configure the signal using:

TRIGger<m>:TV:CUSTom:SCANmode

TRIGger<m>:TV:CUSTom:STYPe

TRIGger<m>:TV:CUSTom:LDURation

TRIGger<m>:TV:CUSTom:SDURation

PAL | PALM | NTSC | SECam

SDTV standards. PALM = PAL-M

PxxxxLyyHZ

HDTV standards using progressive scanning (P). xxxx indicates the number of active lines, yy is the frame rate.

IxxxxLxxHZ

HDTV standards using interlaced scanning (I). xxxx indicates the number of active lines, yy is the field rate.

P1080L24HZSF

1080p/24sF is a HDTV standard using progressive segmented frame scanning.

*RST: PAL

Firmware/Software: FW 1.40

TRIGger<m>:TV:MODE <Mode>

Selects the lines or fields on which the instrument can trigger. Available modes depend on the scanning system.

Suffix:

<m>

1..3

Event in a trigger sequence: 1 = A-event only

Parameters:

<Mode>

ALL | ODD | EVEN | ALINe | LINE

ALL

All fields, triggers on the frame start (progressive scanning) or field start (interlaced and progressive segmented frame scanning)

ODD | EVEN

Only available for interlaced scanning and progressive segmented frame scanning. Triggers on the field start of the odd or even field.

ALINe

All lines, triggers on all line starts.

LINE

Triggers on a specified line. To set the line number, use `TRIGger<m>:TV:LINE`. For NTSC signals, set also the field with `TRIGger<m>:TV:LFIeld`.

*RST: ALL

Firmware/Software: FW 1.40

TRIGger<m>:TV:POLarity <Polarity>

Sets the polarity of the *signal*. Note that the sync pulse has the opposite polarity, for example, a positive signal has a negative sync pulse.

Suffix:

<m>

1..3

Event in a trigger sequence: 1 = A-event only

Parameters:

<Polarity>

POSitive | NEGative

*RST: POSitive

Firmware/Software: FW 1.40

TRIGger<m>:TV:LINE <LineNumber>

Specifies the line number to trigger on. The command is relevant if `TRIGger<m>:TV:MODE` is set to `LINE`.

Usually the lines of the frame are counted beginning from the frame start. For NTSC signals, the lines are counted per field, not per frame. For these signals, set also the field with `TRIGger<m>:TV:LFIeld`.

Suffix:

<m>

1..3

Event in a trigger sequence: 1 = A-event only

Parameters:

<LineNumber> Range: Depends on the standard, see table below
 Increment: 1
 *RST: 1

Firmware/Software: FW 1.40

Standard	Minimum value	Maximum value
PAL	1	625
PAL-M	1	525
NTSC	1	263 in odd field 262 in even field
SECAM	1	625
480p/60 (P480L60HZ)	1	525
720p/30 (P720L30HZ) 720p/50 (P720L50HZ) 720p/60 (P720L60HZ)	1	750
1080i/50 (I1080L50HZ) 1080i/60 (I1080L60HZ) 1080p/24 (P1080L24HZ) 1080p/24sF (P1080L24HZSF) 1080p/25 (P1080L25HZ) 1080p/30 (P1080L30HZ) 1080p/50 (P1080L50HZ) 1080p/60 (P1080L60HZ)	1	1125

TRIGger<m>:TV:LField <LineField>

The commands is only relevant for NTSC signals and sets the field in which the line number is counted.

Suffix:

<m> 1..3
 Event in a trigger sequence: 1 = A-event only

Parameters:

<LineField> FIELD1 | FIELD2
 FIELD1 = odd field
 FIELD2 = even field
 *RST: FIELD1

Firmware/Software: FW 1.40

TRIGger<m>:TV:CUSTom:SCANmode <ScanMode>

Sets the scanning system. Only relevant if **TRIGger<m>:TV:STANdard** is set to **CUSTom**.

See also: "Scan" on page 162.

Suffix:

<m> 1..3
Event in a trigger sequence: 1 = A-event only

Parameters:

<ScanMode> INTerlaced | PROGressive | SEGmented
SEGmented: Progressive segmented frame uses progressive scanning to capture the frame, and interlaced scanning for transmission and display.
*RST: INTerlaced

Firmware/Software: FW 1.40

TRIGger<m>:TV:CUSTom:LDURation <LinePeriod>

Sets the duration of a line, the time between two successive sync pulses. Only relevant if **TRIGger<m>:TV:STANdard** is set to **CUSTom**.

Suffix:

<m> 1..3
Event in a trigger sequence: 1 = A-event only

Parameters:

<LinePeriod> Range: 1E-6 to 500E-6
Increment: 100E-9
*RST: 64E-6
Default unit: s

Firmware/Software: FW 1.40

TRIGger<m>:TV:CUSTom:STYPe <SyncPulseType>

Sets the type of the sync pulse. Only relevant if **TRIGger<m>:TV:STANdard** is set to **CUSTom**.

Suffix:

<m> 1..3
Event in a trigger sequence: 1 = A-event only

Parameters:

<SyncPulseType> BIlevel | TRILevel

BIlevel

Bi-level sync pulse, usually used in SDTV signals

TRILevel

Tri-level sync pulse, used in HDTV signals

*RST: BIlevel

Firmware/Software: FW 1.40**TRIGger<m>:TV:CUSTom:SDURation <SyncPulseDuration>**

Sets the width of the sync pulse. Only relevant if **TRIGger<m>:TV:STANdard** is set to **CUSTom**.

Suffix:

<m> 1..3

Event in a trigger sequence: 1 = A-event only

Parameters:

<SyncPulseDuration> Range: 100E-9 to 100E-6

Increment: 100E-9

*RST: 4.7E-6

Default unit: s

Firmware/Software: FW 1.40**21.2.7.15 Trigger Qualification**

The A-event and B-event in a trigger sequence can have their own trigger qualification. Qualification is not available for R-events (Event-Suffix m = 3) and some trigger types.

The trigger type to which the qualification belongs is defined by a suffix.

Table 21-13: Trigger type suffixes

Suffix	Trigger type
1	EDGE
2	GLITCh
3	WIDTh
4	RUNT
5	WINDow
6	TIMeout
7	INTerval
8	qualification is not supported (SLEWrate)
9	qualification is not supported (DATatoclock)
10	STATe

Suffix	Trigger type
11	PATtern
12	qualification is not supported (ANEDge)
13	currently not used
14	currently not used
15	qualification is not supported (SERPattern)
16	NFC (Near Field Communication), requires option R&S RTO-K11
17	qualification is not supported (TV)
18	qualification is not supported (CDR)

TRIGger<m>:QUALify<n>:STATe.....	734
TRIGger<m>:QUALify<n>:A[:ENABLE].....	734
TRIGger<m>:QUALify<n>:B[:ENABLE].....	734
TRIGger<m>:QUALify<n>:C[:ENABLE].....	735
TRIGger<m>:QUALify<n>:D[:ENABLE].....	735
TRIGger<m>:QUALify<n>:A:LOGic.....	735
TRIGger<m>:QUALify<n>:B:LOGic.....	735
TRIGger<m>:QUALify<n>:C:LOGic.....	735
TRIGger<m>:QUALify<n>:D:LOGic.....	735
TRIGger<m>:QUALify<n>:AB:LOGic.....	736
TRIGger<m>:QUALify<n>:CD:LOGic.....	736
TRIGger<m>:QUALify<n>:ABCD:LOGic.....	736

TRIGger<m>:QUALify<n>:STATe <AddTrigLogic>

Enables the use of the qualification definition for the selected trigger event.

Suffix:

<m>	1..3 Event in a trigger sequence: 1 = A-event, 2 = B-event.
<n>	1..18 Defines the trigger type, see table 21-13 .

Parameters:

<AddTrigLogic>	ON OFF
	ON The qualification expression is considered for the trigger event.
	OFF The qualification expression is ignored for the trigger event.
*RST:	OFF

TRIGger<m>:QUALify<n>:A[:ENABLE] <State>

TRIGger<m>:QUALify<n>:B[:ENABLE] <State>

TRIGger<m>:QUALify<n>:C[:ENABle] <State>

TRIGger<m>:QUALify<n>:D[:ENABle] <State>

Select the channels to be considered for qualification, for pattern trigger and for state trigger:

- A[:ENABle]: CH1
- B[:ENABle]: CH2
- C[:ENABle]: CH3
- D[:ENABle]: CH4

For qualification and state trigger, you can select all channel signals except for the trigger source. In pattern trigger setup, the trigger source channel is selected by default, and you can select all other channel signals.

Suffix:

<m> 1..3
Event in a trigger sequence: 1 = A-event, 2 = B-event (qualification only).

<n> 1..18
Defines the trigger type, see [table 21-13](#).

Parameters:

<State> ON | OFF

ON
The qualification expression is considered.

OFF
The qualification expression is ignored.

*RST: OFF

TRIGger<m>:QUALify<n>:A:LOGic <Operator>

TRIGger<m>:QUALify<n>:B:LOGic <Operator>

TRIGger<m>:QUALify<n>:C:LOGic <Operator>

TRIGger<m>:QUALify<n>:D:LOGic <Operator>

Defines the logic for the indicated channel:

- A: CH1
- B: CH2
- C: CH3
- D: CH4

Suffix:

<m> 1..3
Event in a trigger sequence: 1 = A-event, 2 = B-event.

<n> 1..18
Defines the trigger type, see [table 21-13](#).

Parameters:

<Operator> DIReCt | NOT

DIReCt
Input value remains unchanged

NOT
Input value is inverted

*RST: DIReCt

TRIGger<m>:QUALify<n>:AB:LOGic <Operator>
TRIGger<m>:QUALify<n>:CD:LOGic <Operator>
TRIGger<m>:QUALify<n>:ABCD:LOGic <Operator>

Defines the logical combination of the indicated channels after evaluating the previous logical operations:

- AB: CH1 and CH2
- CD: CH3 and CH4
- ABCD: all four channels

Suffix:

<m> 1..3
Event in a trigger sequence: 1 = A-event, 2 = B-event.

<n> 1..18
Defines the trigger type, see [table 21-13](#).

Parameters:

<Operator> AND | NAND | OR | NOR

AND
logical AND, conjunctive combination

NAND
logical NOT AND

OR
logical OR, disjunctive combination

NOR
logical NOT OR

*RST: AND

21.2.7.16 Noise Reject

TRIGger<m>:LEVel<n>:NOISe[:STATe].....	736
TRIGger<m>:LEVel<n>:NOISe:MODE.....	737
TRIGger<m>:LEVel<n>:NOISe:ABSolute.....	737
TRIGger<m>:LEVel<n>:NOISe:RELative.....	738

TRIGger<m>:LEVel<n>:NOISe[:STATe] <HysteresisMode>

Selects how the hysteresis is set.

Suffix:

<m> 1..3
Event in a trigger sequence, the suffix is irrelevant.

<n> 1..9
Indicates the trigger source:
1...4 = channel 1 to 4, available for all events m = 1 ..3
5 = External Trigger Input on the rear panel for analog signals, available for A-event, m = 1
6...9 = not available

Parameters:

<HysteresisMode> AUTO | MANual

AUTO

This is the recommended mode. The hysteresis is set by the instrument to reject at least the internal noise of the instrument.

You can define a higher minimum value using `TRIGger<m>:`

`LEVel<n>:NOISe:ABSolute`.

MANual

The hysteresis is defined directly with `TRIGger<m>:`

`LEVel<n>:NOISe:ABSolute`.

*RST: AUTO

TRIGger<m>:LEVel<n>:NOISe:MODE <HystSizeMode>

Selects how the hysteresis is set.

Suffix:

<m> 1..3
Event in a trigger sequence, the suffix is irrelevant.

<n> 1..9
Indicates the trigger source:
1...4 = channel 1 to 4, available for all events m = 1 ..3
5 = External Trigger Input on the rear panel for analog signals, available for A-event, m = 1
6...9 = not available

Parameters:

<HystSizeMode> ABS | REL

ABS

The hysteresis is set in absolute values (voltage).

REL

The hysteresis is defined in relative values (div).

*RST: ABS

TRIGger<m>:LEVel<n>:NOISe:ABSolute <HystAbs>

Defines a range in absolute values around the trigger level. If the signal jitters inside this range and crosses the trigger level thereby, no trigger event occurs.

Suffix:

<m>	1..3 Event in a trigger sequence, the suffix is irrelevant.
<n>	1..9 Indicates the trigger source: 1...4 = channel 1 to 4, available for all events m = 1 ..3 5 = External Trigger Input on the rear panel for analog signals, available for A-event, m = 1 6...9 = not available

Parameters:

<HystAbs>	Range: 0 to the value corresponding to five divisions. The exact maximum value depends on the selected vertical scale. Increment: 1E-3 *RST: 0 Default unit: V
-----------	---

TRIGger<m>:LEVel<n>:NOISe:RELative <HystRel>

Defines a range in percent around the trigger level. If the signal jitters inside this range and crosses the trigger level thereby, no trigger event occurs.

Suffix:

<m>	1..3 Event in a trigger sequence, the suffix is irrelevant.
<n>	1..9 Indicates the trigger source: 1...4 = channel 1 to 4, available for all events m = 1 ..3 5 = External Trigger Input on the rear panel for analog signals, available for A-event, m = 1 6...9 = not available

Parameters:

<HystRel>	Range: 0 to 50 Increment: 1 *RST: 0 Default unit: %
-----------	--

21.2.7.17 Trigger Sequence

TRIGger<m>:SEQuence:MODE.....	739
TRIGger<m>:SEQuence:DELAy.....	739
TRIGger<m>:SEQuence:COUNt.....	739
TRIGger<m>:SEQuence:RESet:EVENt.....	740
TRIGger<m>:SEQuence:RESet:TIMeout[:ENABle].....	740
TRIGger<m>:SEQuence:RESet:TIMeout:TIME.....	740
TRIGger<m>:HOLDoff:MODE.....	741
TRIGger<m>:HOLDoff:TIME.....	741

TRIGger<m>:HOLDoff:EVENTs.....	742
TRIGger<m>:HOLDoff:MIN.....	742
TRIGger<m>:HOLDoff:MAX.....	743
TRIGger<m>:HOLDoff:AUTotime?.....	743
TRIGger<m>:HOLDoff:SCALing.....	744

TRIGger<m>:SEQUence:MODE <Type>

Selects the type of the sequence.

See also: [chapter 4.3.4, "Sequence"](#), on page 167.

Suffix:

<m> 1..3
The suffix is irrelevant.

Parameters:

<Type> AONLy | ABR

AONLy

Triggers only on A-events. Additionally, a holdoff condition can be set. If AONLy sequence is set, all inputs (input channels, serial and parallel buses, digital channels etc.) can be used as trigger source.

ABR

Triggers if all conditions of A- and B-events, as well as additional delay and reset timeout or R-event (reset) conditions are fulfilled. This trigger sequence requires that input channels CHAN1...4 are set as trigger sources for all events.

*RST: AONLy

TRIGger<m>:SEQUence:DELay <Delay>

Sets the time the instrument waits after an A-event until it recognizes B-events.

Suffix:

<m> 1..3
The suffix is irrelevant.

Parameters:

<Delay> Range: 0 to 50
Increment: 1E-12
*RST: 0
Default unit: s

TRIGger<m>:SEQUence:COUNT <Events>

Sets the number of B-events to be fulfilled after an A-event. The last B-event causes the trigger.

Suffix:

<m> 1..3
The suffix is irrelevant.

Parameters:

<Events> Range: 1 to 2147483647
Increment: 1
*RST: 1

TRIGger<m>:SEQuence:RESet:EVENT <EnabRstEvt>

If set to ON, the trigger sequence is restarted by the R-event if the specified number of B-event does not occur.

Suffix:

<m> 1..3
The suffix is irrelevant.

Parameters:

<EnabRstEvt> ON | OFF
*RST: OFF

TRIGger<m>:SEQuence:RESet:TIMEout[:ENABLE] <State>

If set to ON, the instrument waits for the time defined using [TRIGger<m>:SEQuence:RESet:TIMEout:TIME](#) for the specified number of B-events. If no trigger occurs during that time, the sequence is restarted with the A-event.

Suffix:

<m> 1..3
The suffix is irrelevant.

Parameters:

<State> ON | OFF
*RST: OFF

TRIGger<m>:SEQuence:RESet:TIMEout:TIME <ResetTimeout>

The time the instrument waits for the number of B-events specified using [TRIGger<m>:SEQuence:COUNT](#) before the sequence is restarted with the A-event.

Suffix:

<m> 1..3
The suffix is irrelevant.

Parameters:

<ResetTimeout> Range: 0 to 50
Increment: 1E-12
*RST: 0
Default unit: s

TRIGger<m>:HOLDoff:MODE <Mode>

Selects the method to define the holdoff condition.

The trigger holdoff defines when the next trigger after the current will be recognized. Thus, it affects the next trigger to occur after the current one. Holdoff helps to obtain stable triggering when the oscilloscope is triggering on undesired events.

Suffix:

<m> 1..3
For holdoff settings, only suffix 1 (A-event) is available.

Parameters:

<Mode> TIME | EVENTs | RANDom | AUTO | OFF

TIME

Defines the holdoff directly as a time period. The next trigger occurs only after the "Holdoff time" has passed (defined using [TRIGger<m>:HOLDoff:TIME](#)).

EVENTs

Defines the holdoff as a number of trigger events. The next trigger occurs only when this number of events is reached. The number of triggers to be skipped is defined using [TRIGger<m>:HOLDoff:EVENTs](#).

RANDom

Defines the holdoff as a random time limited by [TRIGger<m>:HOLDoff:MIN](#) on page 742 and [TRIGger<m>:HOLDoff:MAX](#) on page 743. For each acquisition cycle, the instrument selects a new random holdoff time from the specified range.

AUTO

The holdoff time is calculated automatically based on the current horizontal scale.

OFF

No holdoff

*RST: OFF

TRIGger<m>:HOLDoff:TIME <Time>

Defines the holdoff time period. The next trigger occurs only after this time has passed. The setting is relevant if the holdoff mode is set to TIME.

See also:

- [TRIGger<m>:HOLDoff:MODE](#)

Suffix:

<m> 1..3
For holdoff settings, only suffix 1 (A-event) is available.

Parameters:

<Time> Range: 100E-9 to 10
 Increment: 200E-6
 *RST: 1E-3
 Default unit: s

Example:

```
TRIGger1:HOLDoff:MODE TIME
TRIGger<m>:HOLDoff:TIME 1ms
The holdoff time is set to 1 ms.
```

TRIGger<m>:HOLDoff:EVENTs <Events>

Defines the number of triggers to be skipped. The next trigger only occurs when this number of events is reached. The setting is relevant if the holdoff mode is set to EVENTS.

See also:

- [TRIGger<m>:HOLDoff:MODE](#)

Suffix:

<m> 1..3
 For holdoff settings, only suffix 1 (A-event) is available.

Parameters:

<Events> Range: 1 to 2147483647
 Increment: 10
 *RST: 1

Example:

```
TRIGger1:HOLDoff:MODE EVENTs
TRIGger<m>:HOLDoff:EVENTs 5
```

TRIGger<m>:HOLDoff:MIN <RandomMinTime>

Defines the lower limit for the random time holdoff. The setting is relevant if the holdoff mode is set to RANDOM.

See also:

- [TRIGger<m>:HOLDoff:MODE](#)
- [TRIGger<m>:HOLDoff:MAX](#)

Suffix:

<m> 1..3
 For holdoff settings, only suffix 1 (A-event) is available.

Parameters:

<RandomMinTime> Range: 100E-9 to 5
 Increment: 200E-6
 *RST: 1E-3
 Default unit: s

Example: TRIGger1:HOLDoff:MODE RANDOM
 TRIGger<m>:HOLDoff:MIN 1ms
 TRIGger<m>:HOLDoff:MAX 2ms
 The holdoff time is set randomly between 1 ms and 2 ms.

TRIGger<m>:HOLDoff:MAX <RandomMaxTime>

Defines the upper limit for the random time holdoff. The setting is relevant if the holdoff mode is set to RANDOM.

See also:

- [TRIGger<m>:HOLDoff:MODE](#)
- [TRIGger<m>:HOLDoff:MIN](#)

Suffix:

<m> 1..3
 For holdoff settings, only suffix 1 (A-event) is available.

Parameters:

<RandomMaxTime> Range: 100E-9 to 10
 Increment: 200E-6
 *RST: 2E-3
 Default unit: s

TRIGger<m>:HOLDoff:AUTotime?

Returns the resulting holdoff time if the holdoff mode is set to AUTO: *Auto time = Auto time scaling * Horizontal scale*. The auto time scaling factor is defined with [TRIGger<m>:HOLDoff:SCALing](#).

See also: [TRIGger<m>:HOLDoff:MODE](#)

Suffix:

<m> 1..3
 For holdoff settings, only suffix 1 (A-event) is available.

Return values:

<AutoTime> Holdoff time
 Range: 100E-9 to 10
 *RST: 1E-3
 Default unit: s

Example:

```
TRIGger1:HOLDoff:MODE AUTO
TRIGger1:HOLDoff:SCALing 0.5
TRIGger<m>:HOLDoff:AUTotime?
1ms
Result if the horizontal scale is 1 ns/div
```

Usage: Query only

TRIGger<m>:HOLDoff:SCALing <AutoTimeScaling>

Sets the auto time scaling factor the horizontal scale is multiplied with: *Auto time = Auto time scaling * Horizontal scale*. The setting is relevant if the holdoff mode is set to AUTO.

See also:

- [TRIGger<m>:HOLDoff:MODE](#)
- [TRIGger<m>:HOLDoff:AUTotime?](#) on page 743

Suffix:

<m> 1..3
For holdoff settings, only suffix 1 (A-event) is available.

Parameters:

<AutoTimeScaling> Range: 1E-3 to 1000
Increment: 1
*RST: 0.5

21.2.7.18 Horizontal Position

TIMEbase:HORizontal:POSition	744
TIMEbase:REFerence	744
TIMEbase[:TRIGger]:POSition	745
TRIGger<m>:OFFSet:LIMited	745

TIMEbase:HORizontal:POSition <RescaleCenterTime>

Defines the time distance between the reference point and the trigger point (the zero point of the diagram). The reference point marks the rescaling center of the time scale.

Parameters:

<RescaleCenterTime>Range: -100E+24 to 100E+24
Increment: 1E-12
*RST: 0
Default unit: s

Firmware/Software: V 1.50

TIMEbase:REFerence <RescaleCenterPos>

Sets the position of the reference point in % of the screen. The reference point marks the rescaling center of the time scale. If you modify the time scale, the reference point remains fixed on the screen, and the scale is stretched or compresses to both sides of the reference point.

Parameters:

<RescaleCenterPos> Range: 0 to 100
Increment: 1
*RST: 50
Default unit: %

TIMEbase[:TRIGger]:POSition <Offset>

Defines the time distance from the trigger point to the zero point of the diagram. If the trigger offset is 0, the trigger point matches the zero point.

Legacy command. Use `TIMEbase:HORizontal:POSition` instead.

Parameters:

<Offset> Range: -500 to 500
 Increment: 0.01
 *RST: 0
 Default unit: s

TRIGger<m>:OFFSet:LIMited <State>

Legacy command. Only relevant in connection with `TIMEbase[:TRIGger]:POSition`.

If ON, the range of the trigger offset is limited considering the acquisition time and the reference point. The trigger cannot be set outside the visible waveform diagram.

Suffix:

<m> 1..3
 The numeric suffix is irrelevant.

Parameters:

<State> ON | OFF
 *RST: OFF

21.2.7.19 Trigger Control

<code>TRIGger<m>:MODE</code>	745
<code>TRIGger<m>:FORCe</code>	746
<code>TRIGger<m>:OUT:StAtE</code>	746
<code>TRIGger<m>:OUT:POLarity</code>	746
<code>TRIGger<m>:OUT:PLENgtH</code>	747
<code>TRIGger<m>:OUT:DELay</code>	747

TRIGger<m>:MODE <TriggerMode>

Sets the trigger mode which determines the behaviour of the instrument if no trigger occurs.

See also: "[Trigger mode](#)" on page 174

Suffix:

<m> 1..3
 The numeric suffix is irrelevant.

Parameters:

<TriggerMode> AUTO | NORMAl | FREerun

AUTO

The instrument triggers repeatedly after a time interval if the trigger conditions are not fulfilled. If a real trigger occurs, it takes precedence. The time interval depends on the time base.

NORMAl

The instrument acquires a waveform only if a trigger occurs.

FREerun

The instrument triggers after a very short time interval - faster than in AUTO mode. Real triggers are ignored

*RST: AUTO

TRIGger<m>:FORCe

If the acquisition is running in normal mode and no valid trigger occurs, forcing the trigger provokes an immediate single acquisition. Thus you can confirm that a signal is available and use the waveform display to determine how to trigger on it.

Suffix:

<m> 1..3
irrelevant

Usage: Event

TRIGger<m>:OUT:STATe <State>

Enables/disables the trigger out signal that is provided to the EXT TRIGGER OUT connector on the rear panel when a trigger occurs.

Suffix:

<m> 1..3
The suffix is irrelevant.

Parameters:

<State> ON | OFF
*RST: OFF

TRIGger<m>:OUT:POLarity <Polarity>

Sets the polarity of the trigger out pulse.

Suffix:

<m> 1..3
The suffix is irrelevant.

Parameters:

<Polarity> POSitive | NEGative
*RST: POSitive

TRIGger<m>:OUT:PLENgtH <PulseLength>

Sets the length of the trigger out pulse.

Suffix:

<m> 1..3
The suffix is irrelevant.

Parameters:

<PulseLength> Range: 4E-9 to 1E-3
Increment: 20E-9
*RST: 100E-9
Default unit: s

TRIGger<m>:OUT:DELay <Delay>

Sets the delay of the first pulse edge to the trigger point.

The setting is not available if a mask test or measurement is running and the on-violation event is set to trigger out pulse.

Suffix:

<m> 1..3
The suffix is irrelevant.

Parameters:

<Delay> Range: 800E-9 to 1
Increment: 1E-9
*RST: 800E-9
Default unit: s

21.2.8 Display

- [Signal Colors / Persistence](#)..... 747
- [Color Tables](#)..... 750
- [Diagram Layout](#)..... 752
- [Waveform Labels](#)..... 758
- [Zoom](#)..... 761
- [XY-Diagram](#)..... 769
- [History](#)..... 771

21.2.8.1 Signal Colors / Persistence

- [DISPlay:PERsistence\[:STATe\]](#)..... 748
- [DISPlay:PERsistence:INFinite](#)..... 748
- [DISPlay:PERsistence:TIME](#)..... 748
- [DISPlay:PERsistence:RESet](#)..... 748
- [DISPlay:INTensity](#)..... 748

DISPlay:DIAGram:STYLe.....	749
DISPlay:COLor:SIGNaL<m>:ASSign.....	749
DISPlay:COLor:SIGNaL<m>:USE.....	749

DISPlay:PERSiStence[:STATe] <State>

If enabled, each new data point in the diagram area remains on the screen for the duration defined using `DISPlay:PERSiStence:TIME`, or as long as `DISPlay:PERSiStence:INFinite` is enabled.

If disabled, the signal value is only displayed as long as it actually occurs.

Parameters:

<State> ON | OFF
 *RST: ON

DISPlay:PERSiStence:INFinite <State>

If persistence is enabled (`DISPlay:PERSiStence[:STATe]`), each new data point in the diagram area remains on the screen infinitely until this command is set to "OFF".

Parameters:

<State> ON | OFF
 *RST: OFF

DISPlay:PERSiStence:TIME <Time>

If persistence is enabled (`DISPlay:PERSiStence[:STATe]`), each new data point in the diagram area remains on the screen for the duration defined here.

Parameters:

<Time> Range: 0.05 to 50
 Increment: 0.05
 *RST: 0.05
 Default unit: s

DISPlay:PERSiStence:RESet

Resets the display, removing persistent values.

Usage: Event

DISPlay:INTensity <Intensity>

This value determines the strength of the waveform line in the diagram. Enter a percentage between 0 (not visible) and 100% (very strong).

The exact mapping of the cumulative value occurrences according to the assigned color table is guaranteed only if the intensity is set to 50% (default). All other intensity values falsify the mapping but may improve the visibility of the signal.

See also: [chapter 5.1.2.1, "Editing Waveform Colors"](#), on page 178.

Parameters:

<Intensity> Range: 0 to 100
 Increment: 1
 *RST: 50
 Default unit: %

DISPlay:DIAGram:STYLE <Style>

Select the style in which the waveform is displayed.

Parameters:

<Style> VECTors | DOTS

VECTors

The individual data points are connected by a line.

DOTS

Only the individual data points are displayed.

*RST: VECTors

DISPlay:COLor:SIGNal<m>:ASSign <ColorTable>

Assigns the color table to the specified signal.

Suffix:

<m> 1..67
 Waveform number, see [chapter 21.2.3.1, "Waveform Suffix"](#),
 on page 665.

Parameters:

<ColorTable> Color table name to be assigned to the signal.

DISPlay:COLor:SIGNal<m>:USE <UseColorTable>

If enabled, the selected waveform is displayed according to its assigned color table.

If this option is disabled, the default color table is used, i.e. the intensity of the specific signal color varies according to the cumulative occurrence of the values.

Suffix:

<m> 1..67
 Waveform number, see [chapter 21.2.3.1, "Waveform Suffix"](#),
 on page 665.

Parameters:

<UseColorTable> ON | OFF
 *RST: OFF

21.2.8.2 Color Tables

| | |
|---|-----|
| DISPlay:COLor:PALETTE:ADD..... | 750 |
| DISPlay:COLor:PALETTE:REMove..... | 750 |
| DISPlay:COLor:PALETTE:COUNT?..... | 750 |
| DISPlay:COLor:PALETTE:POINT:ADD..... | 750 |
| DISPlay:COLor:PALETTE:POINT:INSert..... | 750 |
| DISPlay:COLor:PALETTE:POINT:REMove..... | 751 |
| DISPlay:COLor:PALETTE:POINT[VALue]..... | 751 |
| DISPlay:COLor:PALETTE:POINT:COUNT?..... | 751 |

DISPlay:COLor:PALETTE:ADD <Name>

Adds a new color table with the specified name.

Setting parameters:

<Name> color table

Usage: Setting only

DISPlay:COLor:PALETTE:REMove <Name>

Removes the specified color table.

Setting parameters:

<Name> color table

Usage: Setting only

DISPlay:COLor:PALETTE:COUNT?

Queries the number of configured color maps.

Usage: Query only

DISPlay:COLor:PALETTE:POINT:ADD <PaletteName>

Appends a new row at the end of the color table.

Setting parameters:

<PaletteName> color table

Usage: Setting only

DISPlay:COLor:PALETTE:POINT:INSert <PaletteName>, <PointIndex>

Inserts the entry at the specified index in the color table.

Setting parameters:

<PaletteName> color table

<PointIndex> row number in the color table

Usage: Setting only

DISPlay:COLor:PALETTE:POINT:REMOve <PaletteName>, <PointIndex>

Removes the entry with the specified index from the color table.

Setting parameters:

<PaletteName> color table

<PointIndex> row number in the color table

Usage: Setting only

DISPlay:COLor:PALETTE:POINT[:VALue] <ColorTableName>, <ColorTableColorPointIdx>, <Position>, <Color>

DISPlay:COLor:PALETTE:POINT[:VALue]? <ColorTableName>, <ColorTableColorPointIdx>

Inserts a new entry or queries the specified entry in the specified color table.

Parameters:

<Position> cumulative occurrence value

Range: 0 to 100

Increment: 1

*RST: 50

Default unit: %

<Color> ARGB value of the color to be used for the table entry. ARGB=<Opacity(alpha) value><red value><green value><blue value>, in hexadecimal or decimal format.

Range: 0 to 4294967295

Increment: 1

*RST: 0

Parameters for setting and query:

<ColorTableName> color table to be edited

<ColorTableColorPointIdx> (row number) of the new entry in the color table

DISPlay:COLor:PALETTE:POINT:COUNT? <PaletteName>

Queries the number of entries in the color table.

Query parameters:

<PaletteName> color table

Usage: Query only

21.2.8.3 Diagram Layout

| | |
|---------------------------------------|-----|
| DISPlay:DIAGram:GRID..... | 752 |
| DISPlay:DIAGram:CROSShair..... | 752 |
| DISPlay:DIAGram:FINegrid..... | 752 |
| DISPlay:DIAGram:LABels..... | 753 |
| DISPlay:DIAGram:TITLe..... | 753 |
| DISPlay:DIAGram:YFIXed..... | 753 |
| DISPlay:SIGBar[:STATe]..... | 753 |
| DISPlay:SIGBar:POSition..... | 753 |
| DISPlay:SIGBar:HIDE[:AUTO]..... | 754 |
| DISPlay:SIGBar:HIDE:TIME..... | 754 |
| DISPlay:SIGBar:HIDE:HEAD..... | 754 |
| DISPlay:SIGBar:HIDE:TRANSparency..... | 754 |
| DISPlay:SIGBar:COLor:BORDER..... | 754 |
| DISPlay:SIGBar:COLor:FILL..... | 755 |
| DISPlay:RESultboxes:DEFaultpos..... | 755 |
| LAYout:ADD..... | 755 |
| LAYout:REMOve..... | 756 |
| LAYout:SHOW..... | 756 |
| LAYout:SIGNal:ASSign..... | 756 |
| LAYout:SIGNal:AXIS..... | 757 |
| LAYout:SIGNal:UNASsign..... | 757 |

DISPlay:DIAGram:GRID <Show>

If enabled, a grid is displayed in the diagram area.

Parameters:

<Show> ON | OFF
 *RST: ON

DISPlay:DIAGram:CROSShair <Crosshair>

If selected, a crosshair is displayed in the diagram area. A crosshair allows you to select a specific data point by its co-ordinates.

Parameters:

<Crosshair> ON | OFF
 *RST: ON

DISPlay:DIAGram:FINegrid <ShowFineScale>

If ON, the crosshair is displayed as a ruler with scale markers. If OFF, the crosshair is shown as dashed lines.

Parameters:

<ShowFineScale> ON | OFF
 *RST: ON

Firmware/Software: V 1.50

DISPlay:DIAGram:LABels <ShowLabels>

If enabled, labels mark values on the x- and y-axes in specified intervals in the diagram.

Parameters:

<ShowLabels> ON | OFF
 *RST: ON

DISPlay:DIAGram:TITLe <DiagTitleState>

If enabled, the tab titles of all diagrams are displayed: "Diagram1", "Diagram2" ...

If disabled, the tab titles are not shown except for those in a tabbed diagram. In tabbed diagrams, the tab titles are required to change the tabs.

Parameters:

<DiagTitleState> ON | OFF
 *RST: ON

DISPlay:DIAGram:YFIXed <YGridFixed>

If enabled, the horizontal grid lines remain in their position when the position of the curve is changed. Only the values at the grid lines are adapted. This reflects the behavior of traditional oscilloscopes.

Parameters:

<YGridFixed> ON | OFF
 *RST: ON

DISPlay:SIGBar[:STATe] <State>

If enabled, the signal bar is displayed in the diagram area.

Parameters:

<State> ON | OFF
 *RST: ON

DISPlay:SIGBar:POSition <Position>

The signal bar can be placed vertically at the right (default position) or at the left, or horizontally at the top, bottom or center of the diagram to ensure best visibility of the waveforms.

Parameters:

<Position> LEFT | RIGHT
 *RST: RIGHT

DISPlay:SIGBar:HIDE[:AUTO] <AutoHide>

If enabled, the signal bar disappears automatically after some time, similar to the Windows task bar. With the commands `DISPlay:SIGBar:HIDE:TIME` and `DISPlay:SIGBar:HIDE:TRANsparency`, you can define when and how the signal bar hides.

The signal bar reappears if you tap it, or if an action changes the content of the bar.

Parameters:

<AutoHide> ON | OFF
 *RST: OFF

DISPlay:SIGBar:HIDE:TIME <AutoHideTime>

Sets the time when the signal bar is faded out if `DISPlay:SIGBar:HIDE[:AUTO]` is "ON".

Parameters:

<AutoHideTime> Range: 0.03 to 86.4E+3
 Increment: 0.5
 *RST: 5
 Default unit: s

DISPlay:SIGBar:HIDE:HEAD <HideHeadAlso>

If enabled, the "Auto hide" function hides also the horizontal and trigger label at the top of the signal bar.

Parameters:

<HideHeadAlso> ON | OFF
 *RST: ON

DISPlay:SIGBar:HIDE:TRANsparency <HidingTransparency>

Sets the transparency of the signal bar when the signal bar is faded out with `DISPlay:SIGBar:HIDE[:AUTO]`.

Parameters:

<HidingTransparency> Range: 20 to 70
 Increment: 5
 *RST: 50
 Default unit: %

DISPlay:SIGBar:COLor:BORDER <BorderColor>

Defines the color of the signal bar border.

See also: "[To change the colors](#)" on page 82.

Parameters:

<BorderColor> ARGB color value
 Range: 0 to 4294967295
 Increment: 1
 *RST: 0

DISPlay:SIGBar:COLor:FILL <FillColor>

Define the fill color of the signal bar.

See also: ["To change the colors"](#) on page 82.

Parameters:

<FillColor> ARGB color value
 Range: 0 to 4294967295
 Increment: 1
 *RST: 0

DISPlay:RESultboxes:DEFaultpos <State>

Defines where a new result box opens.

Parameters:

<State> PREV | FLOA

PREV

Preview: The result box opens as a minimized result icon on the signal bar. It shows only two columns and a few rows of the results.

FLOA

Floating: The result box opens as a box similar to a dialog box in front of the diagrams. It can be moved and shows all results.

*RST: does not affect the setting

LAYout:ADD <NodeName>, <ParentType>, <InsertBefore>, <FirstSource>, <DiagramName>

Adds a new diagram with a waveform on the screen, in relation to an existing diagram.

Setting parameters:

<NodeName> String with the name of the existing diagram

<ParentType> HORizontal | VERTical | TAB

Position of the new diagram in relation to the existing one.

HORizontal

Besides the existing diagram

VERTical

Above or below the existing diagram

TAB

In a new tab in the existing diagram

| | |
|-----------------|---|
| <InsertBefore> | ON OFF
If on, the new diagram is inserted to the left (for HORizontal), above (for VERTical) or in a tab in front the existing diagram.
HOR, ON = left to the existing diagram, defined in <NodeName>
HOR, OFF = right to the existing diagram
VERT, ON = above the existing diagram
VERT, OFF = below the existing diagram |
| <FirstSource> | C1W1 C1W2 C1W3 C2W1 C2W2 C2W3 C3W1 C3W2 C3W3 C4W1 C4W2 C4W3 M1 M2 M3 M4 R1 R2 R3 R4 XY1 XY2 XY3 XY4 MRESult1 MRESult2 MRESult3 MRESult4 MRESult5 MRESult6 MRESult7 MRESult8 SBUS1 SBUS2 SBUS3 SBUS4 D0 D1 D2 D3 D4 D5 D6 D7 D8 D9 D10 D11 D12 D13 D14 D15 MSOB1 MSOB2 MSOB3 MSOB4 TRK1 TRK2 TRK3 TRK4 TRK5 TRK6 TRK7 TRK8
Waveform to be displayed in the new diagram, see chapter 21.2.3.2, "Waveform Parameter" , on page 666. |
| <DiagramName> | String with the name of the new diagram. |
| Example: | <code>LAYout:ADD 'Diagram2', TAB, ON, C4W1, 'MyDiagram3'</code>
Creates a new diagram 'MyDiagram3' with waveform C4W1 in a new tab that is laid in front of 'Diagram2'. |
| Usage: | Setting only |

LAYout:REMove <DiagramName>

Closes the specified diagram. The waveforms are displayed as minimized waveforms in their signal icons in the signal bar.

Setting parameters:

<DiagramName> String with the name of the diagram

Usage: Setting only

LAYout:SHOW <DiagramName>

Selects the specified diagram.

Setting parameters:

<DiagramName> String with the name of the diagram

Usage: Setting only

LAYout:SIGNal:ASSign <DiagramName>, <Source>

Shows the specified waveform in the selected diagram.

Setting parameters:

<DiagramName> String with the diagram name

<Source> NONE | C1W1 | C1W2 | C1W3 | C2W1 | C2W2 | C2W3 | C3W1 | C3W2 | C3W3 | C4W1 | C4W2 | C4W3 | M1 | M2 | M3 | M4 | R1 | R2 | R3 | R4 | XY1 | XY2 | XY3 | XY4 | MRESult1 | MRESult2 | MRESult3 | MRESult4 | MRESult5 | MRESult6 | MRESult7 | MRESult8 | SBUS1 | SBUS2 | SBUS3 | SBUS4 | D0 | D1 | D2 | D3 | D4 | D5 | D6 | D7 | D8 | D9 | D10 | D11 | D12 | D13 | D14 | D15 | MSOB1 | MSOB2 | MSOB3 | MSOB4 | TRK1 | TRK2 | TRK3 | TRK4 | TRK5 | TRK6 | TRK7 | TRK8

Waveform to be assigned, see [chapter 21.2.3.2, "Waveform Parameter"](#), on page 666

Usage: Setting only

LAYout:SIGNal:AXIS <DiagramName>, <Source>, <XSource>

Creates an XY-diagram by adding a second waveform to a diagram with a channel, math or reference waveform.

Setting parameters:

<DiagramName> String with the name of the diagram where the waveform is added.

<Source> C1W1 | C1W2 | C1W3 | C2W1 | C2W2 | C2W3 | C3W1 | C3W2 | C3W3 | C4W1 | C4W2 | C4W3 | M1 | M2 | M3 | M4 | R1 | R2 | R3 | R4

Waveform to be added, see [chapter 21.2.3.2, "Waveform Parameter"](#), on page 666

<XSource> ON | OFF

If on, the added waveform is assigned to the x-axis.
If off, it is assigned to the y-axis.

Usage: Setting only

LAYout:SIGNal:UNASsign <Source>

Removes the specified waveform from the diagram.

Setting parameters:

<Source> NONE | C1W1 | C1W2 | C1W3 | C2W1 | C2W2 | C2W3 | C3W1 | C3W2 | C3W3 | C4W1 | C4W2 | C4W3 | M1 | M2 | M3 | M4 | R1 | R2 | R3 | R4 | XY1 | XY2 | XY3 | XY4 | MRESult1 | MRESult2 | MRESult3 | MRESult4 | MRESult5 | MRESult6 | MRESult7 | MRESult8 | SBUS1 | SBUS2 | SBUS3 | SBUS4 | D0 | D1 | D2 | D3 | D4 | D5 | D6 | D7 | D8 | D9 | D10 | D11 | D12 | D13 | D14 | D15 | MSOB1 | MSOB2 | MSOB3 | MSOB4 | TRK1 | TRK2 | TRK3 | TRK4 | TRK5 | TRK6 | TRK7 | TRK8

See [chapter 21.2.3.2, "Waveform Parameter"](#), on page 666

*RST: NONE

Usage: Setting only

21.2.8.4 Waveform Labels

To create a new waveform label, use `DISPlay:SIGNal:LABel:ADD`. Using the other `DISP:SIGN:LAB:...` commands, you can query the text and position of a label, and modify the initial settings. The `<LabelID>` and `<Source>` parameters identify each label uniquely. Note that it is not possible to query the `<LabelID>`, or to read it on the user interface.

| | |
|--|-----|
| <code>DISPlay:SIGNal:LABel:ADD</code> | 758 |
| <code>DISPlay:SIGNal:LABel:REMove</code> | 759 |
| <code>DISPlay:SIGNal:LABel:TEXT</code> | 759 |
| <code>DISPlay:SIGNal:LABel:POSMode</code> | 759 |
| <code>DISPlay:SIGNal:LABel:HORizontal:ABSolute:POSition</code> | 760 |
| <code>DISPlay:SIGNal:LABel:VERTical:ABSolute:POSition</code> | 760 |
| <code>DISPlay:SIGNal:LABel:HORizontal:RELative:POSition</code> | 761 |
| <code>DISPlay:SIGNal:LABel:VERTical:RELative:POSition</code> | 761 |

DISPlay:SIGNal:LABel:ADD `<LabelID>`, `<Source>`, `<LabelText>`, `<PositionMode>`,
`<XPositon>`, `<YPositon>`

Creates a new waveform label for the specified source waveform.

Setting parameters:

| | |
|-----------------------------------|--|
| <code><LabelID></code> | String with the label identifier. The <code><LabelID></code> and <code><Source></code> parameters identify each label uniquely, so the label ID must be unique for the given waveform. Note the <code><LabelID></code> because it is not possible to query it, or to read it on the user interface. |
| <code><Source></code> | C1W1 C1W2 C1W3 C2W1 C2W2 C2W3 C3W1 C3W2 C3W3 C4W1 C4W2 C4W3 M1 M2 M3 M4 R1 R2 R3 R4 XY1 XY2 XY3 XY4 MRESult1 MRESult2 MRESult3 MRESult4 MRESult5 MRESult6 MRESult7 MRESult8 IMResult SBUS1 SBUS2 SBUS3 SBUS4 D0 D1 D2 D3 D4 D5 D6 D7 D8 D9 D10 D11 D12 D13 D14 D15 MSOB1 MSOB2 MSOB3 MSOB4 TRK1 TRK2 TRK3 TRK4 TRK5 TRK6 TRK7 TRK8
Waveform to that the label belongs |
| <code><LabelText></code> | String with the label text that is shown on the display |
| <code><PositionMode></code> | ABS REL
ABS
Position in time and voltage values, or in other units depending on the waveform character. Absolute positions move with the waveform display when the scales, the vertical position or offset, or the reference point are changed.
REL
Fixed label position in percent of the screen counting from the upper left corner. |

| | |
|-----------------|---|
| <XPositon> | Horizontal position of the label text. Values, range and unit depend on the position mode, the waveform position and scaling. For relative position mode, the range is 0 to 100 %. |
| <YPositon> | Vertical position of the label text. Values, range and unit depend on the position mode, the waveform position and scaling. For relative position mode, the range is 0 to 100 %. |
| Example: | <pre>DISPlay:SIGNal:LABel:ADD 'Label1', C1W1, 'Label on C1W1', REL, 20, 20</pre> <p>Adds the label text 'Label on C1W1' to waveform1 of channel1 at relative position 20% from the upper left corner of the screen. The label ID is 'Label1'.</p> |
| Example: | <pre>DISPlay:SIGNal:LABel:ADD 'Label1', C2W1, 'Label on C2W1', ABS, 10e-09, 0.1</pre> <p>Adds the label text 'Label on C2W1' to waveform1 of channel2 at absolute position 10 ns and 0.1 V. The label ID is 'Label1'.</p> |
| Usage: | Setting only |

DISPlay:SIGNal:LABel:REMOve <LabelID>, <Source>

Deletes the specifies waveform label.

Setting parameters:

<LabelID>	String with the label identifier.
<Source>	All waveforms, see DISPlay:SIGNal:LABel:ADD

Example: `DISPlay:SIGNal:LABel:REMOve 'Label1', C1W1`

Usage: Setting only

DISPlay:SIGNal:LABel:TEXT <LabelID>, <Source>, <LabelText>

DISPlay:SIGNal:LABel:TEXT? <LabelID>, <Source>

Modifies or queries the text of the specified label.

Parameters:

<LabelText>	String with the label text that is shown
-------------	--

Parameters for setting and query:

<LabelID>	String with the label identifier.
<Source>	All waveforms, see DISPlay:SIGNal:LABel:ADD

DISPlay:SIGNal:LABel:POSMode <Source>, <PositionMode>

DISPlay:SIGNal:LABel:POSMode? <Source>

Modifies or queries the position mode: either relative to the diagram or with absolute values according to the units of the waveform. The position mode applies to all labels of the selected source. For different sources, different position modes can be selected.

Parameters:

<PositionMode> ABS | REL

ABS

Position in time and voltage values, or in other units depending on the waveform character. Absolute positions move with the waveform display when the scales, the vertical position or offset, or the reference point are changed.

Use `DISPlay:SIGNal:LABel:HORizontal:ABSolute:POSition` and `DISPlay:SIGNal:LABel:HORizontal:RELative:POSition` to set the position.

REL

Fixed label position in percent of the screen counting from the upper left corner.

Use `DISPlay:SIGNal:LABel:HORizontal:RELative:POSition` and `DISPlay:SIGNal:LABel:VERTical:RELative:POSition` to set the position.

Parameters for setting and query:

<Source> All waveforms, see `DISPlay:SIGNal:LABel:ADD`

`DISPlay:SIGNal:LABel:HORizontal:ABSolute:POSition` <LabelID>, <Source>, <Position>

`DISPlay:SIGNal:LABel:HORizontal:ABSolute:POSition?` <LabelID>, <Source>

`DISPlay:SIGNal:LABel:VERTical:ABSolute:POSition` <LabelID>, <Source>, <Position>

`DISPlay:SIGNal:LABel:VERTical:ABSolute:POSition?` <LabelID>, <Source>

Modifies or queries the absolute horizontal and vertical positions of the specified label if `DISPlay:SIGNal:LABel:POSMode` is set to ABS.

Parameters:

<Position> Range: depends on waveform position and scaling
Default unit: s and V, or in other units depending on the waveform character

Parameters for setting and query:

<LabelID> String with the label identifier.

<Source> All waveforms, see `DISPlay:SIGNal:LABel:ADD`

Example:

```
DISPlay:SIGNal:LABel:HORizontal:ABSolute:
```

```
POSition 'Label1', C2W1, 5e-09
```

```
DISPlay:SIGNal:LABel:VERTical:ABSolute:POSition
```

```
'Label1', C2W1, -0.1
```

Move the label to 5 ns and -0.1 V.

DISPlay:SIGNal:LABel:HORizontal:RELative:POSition <LabelID>, <Source>, <Position>

DISPlay:SIGNal:LABel:HORizontal:RELative:POSition? <LabelID>, <Source>

DISPlay:SIGNal:LABel:VERTical:RELative:POSition <LabelID>, <Source>, <Position>

DISPlay:SIGNal:LABel:VERTical:RELative:POSition? <LabelID>, <Source>

Modifies or queries the relative horizontal and vertical positions of the specified label if [DISPlay:SIGNal:LABel:POSMode](#) is set to REL.

Parameters:

<Position> Position in percent of the screen counting from the upper left corner.

Range: 0 to 100

Default unit: %

Parameters for setting and query:

<LabelID> String with the label identifier.

<Source> All waveforms, see [DISPlay:SIGNal:LABel:ADD](#)

Example:

```
DISPlay:SIGNal:LABel:HORizontal:RELative:
POSition 'Label1', C1W1, 30
```

```
DISPlay:SIGNal:LABel:VERTical:RELative:POSition
'Label1', C1W1, 70
```

Move the label to new relative position: horizontal at 30 % and vertical at 70 % of the screen.

21.2.8.5 Zoom

LAYout:ZOOM:ADD	762
LAYout:ZOOM:ADDCoupled	762
LAYout:ZOOM:ONEDiagram	763
LAYout:ZOOM:POSCoupling	763
LAYout:ZOOM:HORZ:MODE	763
LAYout:ZOOM:HORZ:ABSolute:POSition	763
LAYout:ZOOM:HORZ:ABSolute:SPAN	764
LAYout:ZOOM:HORZ:ABSolute:START	764
LAYout:ZOOM:HORZ:ABSolute:STOP	764
LAYout:ZOOM:HORZ:RELative:POSition	765
LAYout:ZOOM:HORZ:RELative:SPAN	765
LAYout:ZOOM:HORZ:RELative:START	765
LAYout:ZOOM:HORZ:RELative:STOP	766
LAYout:ZOOM:VERTical:MODE	766
LAYout:ZOOM:VERTical:ABSolute:POSition	766
LAYout:ZOOM:VERTical:ABSolute:SPAN	767
LAYout:ZOOM:VERTical:ABSolute:START	767
LAYout:ZOOM:VERTical:ABSolute:STOP	767
LAYout:ZOOM:VERTical:RELative:POSition	767
LAYout:ZOOM:VERTical:RELative:SPAN	768

LAYout:ZOOM:VERTical:RELative:START.....	768
LAYout:ZOOM:VERTical:RELative:STOP.....	768
LAYout:ZOOM:REMove.....	769

LAYout:ZOOM:ADD <NodeName>, <ParentType>, <InsertBefore>, <XStart>, <XStop>, <YStart>, <YStop>, <ZoomName>

Adds a new zoom diagram based on the specified waveform.

Setting parameters:

<NodeName>	String with the name of diagram to be zoomed
<ParentType>	VERTical, OFF The new zoom diagram is displayed below the original one.
<InsertBefore>	OFF Position of the zoom diagram, depending on ParentType
<XStart>	Defines the x-value at the beginning of the zoom area.
<XStop>	Defines the x-value at the end of the zoom area.
<YStart>	Defines the y-value at the beginning of the zoom area.
<YStop>	Defines the y-value at the end of the zoom area.
<NewZoomName>	String with the name of the new zoom diagram.

Example: LAYout:ZOOM:ADD 'Diagram1', VERT, OFF, -10e-9, 20e-9, -0.1, 0.05, 'MyZoom1'
Creates the zoom diagram 'MyZoom1' for 'Diagram1'.

Example: See [chapter 21.3.1.1, "Creating Zoom Diagrams"](#), on page 1127

Usage: Setting only

LAYout:ZOOM:ADDCoupled <ZoomName>, <XOffset>, <YOffset>, <NewZoomName>

Creates a new zoom diagram based on the settings of an existing zoom area for the same source.

Parameters:

<NewZoomName>	Defines the name of the new zoom diagram.
---------------	---

Setting parameters:

<ZoomName>	Defines the name of the zoom diagram to be copied.
<XOffset>	Defines an offset to the existing zoom area in x direction.
<YOffset>	Defines an offset to the existing zoom area in y direction.

LAYout:ZOOM:ONEDiagram <ShowInOne>

Shows all zooms of a diagram in one zoom window. The zoomed areas are overlaid for better comparison of the zoomed waveforms.

The command takes effect on all zoom diagrams.

Parameters:

<ShowInOne> ON | OFF
 *RST: OFF

LAYout:ZOOM:POSCoupling <DiagramName>, <ZoomName>, <PositionCoupl>
LAYout:ZOOM:POSCoupling? <DiagramName>, <ZoomName>

Enables or disables the position coupling of coupled zooms. If position coupling is enabled and one zoom area is moved, the other coupled zoom areas are moved, too, and keep their distance.

Parameters:

<PositionCoupl> ON | OFF
 *RST: OFF

Parameters for setting and query:

<DiagramName> String with the name of the diagram on which the zoom is based
 <ZoomName> String with the name of the zoom diagram

LAYout:ZOOM:HORZ:MODE <DiagramName>, <ZoomName>, <Mode>
LAYout:ZOOM:HORZ:MODE? <DiagramName>, <ZoomName>

Defines whether absolute or relative values are used to specify the x-axis values. Since the zoom area refers to the active signal, relative values ensure that the zoom area remains the same.

Parameters:

<Mode> ABS | REL
 Mode used to specify the x-axis values of the zoom area.
 *RST: ABS

Parameters for setting and query:

<DiagramName> Name of the diagram on which the zoom area is based.
 <ZoomName> Name of the zoom diagram

Example: See [chapter 21.3.1.1, "Creating Zoom Diagrams"](#),
 on page 1127

LAYout:ZOOM:HORZ:ABSolute:POSition <DiagramName>,
 <ZoomName>, <Position>
LAYout:ZOOM:HORZ:ABSolute:POSition? <DiagramName>, <ZoomName>

Defines the x-value of the centerpoint of the zoom area.

Parameters:

<Position> Range: -100E+24 to 100E+24
 Increment: 0.01
 *RST: 0.01

Parameters for setting and query:

<DiagramName> Name of the diagram on which the zoom area is based.
 <ZoomName> Name of the zoom diagram

LAYout:ZOOM:HORIZ:ABSolute:SPAN <DiagramName>, <ZoomName>,

LAYout:ZOOM:HORIZ:ABSolute:SPAN? <DiagramName>, <ZoomName>

Defines the width of the zoom area.

Parameters:

 Range: 0 to 100E+24
 Increment: 0.01
 *RST: 0.01

Parameters for setting and query:

<DiagramName> Name of the diagram on which the zoom area is based.
 <ZoomName> Name of the zoom diagram

LAYout:ZOOM:HORIZ:ABSolute:START <DiagramName>, <ZoomName>, <Start>

LAYout:ZOOM:HORIZ:ABSolute:START? <DiagramName>, <ZoomName>

Defines the lower limit of the zoom area on the x-axis.

Parameters:

<Start> Range: -100E+24 to 100E+24
 Increment: 0.01
 *RST: 0.01

Parameters for setting and query:

<DiagramName> Name of the diagram on which the zoom area is based.
 <ZoomName> Name of the zoom diagram

LAYout:ZOOM:HORIZ:ABSolute:STOP <DiagramName>, <ZoomName>, <Stop>

LAYout:ZOOM:HORIZ:ABSolute:STOP? <DiagramName>, <ZoomName>

Defines the upper limit of the zoom area on the x-axis.

Parameters:

<Stop> Range: -100E+24 to 100E+24
 Increment: 0.01
 *RST: 0.01

Parameters for setting and query:

<DiagramName> Name of the diagram on which the zoom area is based.
 <ZoomName> Name of the zoom diagram

LAYout:ZOOM:HORIZ:RELative:POSition <DiagramName>,
<ZoomName>,<RelPosi>

LAYout:ZOOM:HORIZ:RELative:POSition? <DiagramName>, <ZoomName>

Defines the x-value of the centerpoint of the zoom area.

Parameters:

<RelPosi> Relative position of the centerpoint (x-value)
 Range: -100E+24 to 100E+24
 Increment: 0.1
 *RST: 100
 Default unit: %

Parameters for setting and query:

<DiagramName> Name of the diagram on which the zoom area is based.
 <ZoomName> Name of the zoom diagram

Example: See [chapter 21.3.1.1, "Creating Zoom Diagrams"](#),
on page 1127

LAYout:ZOOM:HORIZ:RELative:SPAN <DiagramName>,
<ZoomName>,<RelativeSpan>

LAYout:ZOOM:HORIZ:RELative:SPAN? <DiagramName>, <ZoomName>

Defines the width of the zoom area.

Parameters:

<RelativeSpan> Range: -100E+24 to 100E+24
 Increment: 0.1
 *RST: 0
 Default unit: %

Parameters for setting and query:

<DiagramName> Name of the diagram on which the zoom area is based.
 <ZoomName> Name of the zoom diagram

Example: See [chapter 21.3.1.1, "Creating Zoom Diagrams"](#),
on page 1127

LAYout:ZOOM:HORIZ:RELative:STARt <DiagramName>,
<ZoomName>,<RelativeStart>

LAYout:ZOOM:HORIZ:RELative:STARt? <DiagramName>, <ZoomName>

Defines the lower limit of the zoom area on the x-axis.

Parameters:

<RelativeStart> Range: -100E+24 to 100E+24
 Increment: 0.1
 *RST: 0
 Default unit: %

Parameters for setting and query:

<DiagramName> Name of the diagram on which the zoom area is based.

<ZoomName> Name of the zoom diagram

LAYout:ZOOM:HORZ:RELative:STOP <DiagramName>,
<ZoomName>,<RelativeStop>

LAYout:ZOOM:HORZ:RELative:STOP? <DiagramName>, <ZoomName>

Defines the upper limit of the zoom area on the x-axis.

Parameters:

<RelativeStop> Range: -100E+24 to 100E+24
Increment: 0.1
*RST: 100
Default unit: %

Parameters for setting and query:

<DiagramName> Name of the diagram on which the zoom area is based.

<ZoomName> Name of the zoom diagram

LAYout:ZOOM:VERTical:MODE <DiagramName>, <ZoomName>,<Mode>

LAYout:ZOOM:VERTical:MODE? <DiagramName>, <ZoomName>

Defines whether absolute or relative values are used to specify the y-axis values.

Since the zoom area refers to the active signal, relative values ensure that the zoom area remains the same.

Parameters:

<Mode> ABS | REL
Mode used to specify the y-axis values of the zoom area.
*RST: ABS

Parameters for setting and query:

<DiagramName> Name of the diagram on which the zoom area is based.

<ZoomName> Name of the zoom diagram

LAYout:ZOOM:VERTical:ABSolute:POSITION <DiagramName>,
<ZoomName>,<Position>

LAYout:ZOOM:VERTical:ABSolute:POSITION? <DiagramName>, <ZoomName>

Defines the y-value of the centerpoint of the zoom area.

Parameters:

<Position> Range: -100E+24 to 100E+24
Increment: 0.01
*RST: 0.01

Parameters for setting and query:

<DiagramName> Name of the diagram on which the zoom area is based.

<ZoomName> Name of the zoom diagram

LAYout:ZOOM:VERTical:ABSolute:SPAN <DiagramName>, <ZoomName>,
LAYout:ZOOM:VERTical:ABSolute:SPAN? <DiagramName>, <ZoomName>

Defines the height of the zoom area.

Parameters:

 Range: 0 to 100E+24
 Increment: 0.01
 *RST: 0.01

Parameters for setting and query:

<DiagramName> Name of the diagram on which the zoom area is based.
 <ZoomName> Name of the zoom diagram

LAYout:ZOOM:VERTical:ABSolute:START <DiagramName>, <ZoomName>,<Start>
LAYout:ZOOM:VERTical:ABSolute:START? <DiagramName>, <ZoomName>

Defines the lower limit of the zoom area on the y-axis.

Parameters:

<Start> Range: -100E+24 to 100E+24
 Increment: 0.01
 *RST: 0.01

Parameters for setting and query:

<DiagramName> Name of the diagram on which the zoom area is based.
 <ZoomName> Name of the zoom diagram

LAYout:ZOOM:VERTical:ABSolute:STOP <DiagramName>, <ZoomName>,<Stop>
LAYout:ZOOM:VERTical:ABSolute:STOP? <DiagramName>, <ZoomName>

Defines the upper limit of the zoom area on the y-axis.

Parameters:

<Stop> Range: -100E+24 to 100E+24
 Increment: 0.01
 *RST: 0.01

Parameters for setting and query:

<DiagramName> Name of the diagram on which the zoom area is based.
 <ZoomName> Name of the zoom diagram

LAYout:ZOOM:VERTical:RELative:POSition <DiagramName>,
 <ZoomName>,<RelPosi>
LAYout:ZOOM:VERTical:RELative:POSition? <DiagramName>, <ZoomName>

Defines the y-value of the centerpoint of the zoom area.

Parameters:

<RelPosi> Relative position of the centerpoint (y-value)
 Range: -100E+24 to 100E+24
 Increment: 0.1
 *RST: 100
 Default unit: %

Parameters for setting and query:

<DiagramName> Name of the diagram on which the zoom area is based.
 <ZoomName> Name of the zoom diagram

LAYout:ZOOM:VERTical:RELative:SPAN <DiagramName>,
 <ZoomName>,<RelativeSpan>

LAYout:ZOOM:VERTical:RELative:SPAN? <DiagramName>, <ZoomName>

Defines the height of the zoom area.

Parameters:

<RelativeSpan> Range: -100E+24 to 100E+24
 Increment: 0.1
 *RST: 0
 Default unit: %

Parameters for setting and query:

<DiagramName> Name of the diagram on which the zoom area is based.
 <ZoomName> Name of the zoom diagram

LAYout:ZOOM:VERTical:RELative:START <DiagramName>,
 <ZoomName>,<RelativeStart>

LAYout:ZOOM:VERTical:RELative:START? <DiagramName>, <ZoomName>

Defines the lower limit of the zoom area on the y-axis.

Parameters:

<RelativeStart> Range: -100E+24 to 100E+24
 Increment: 0.1
 *RST: 0
 Default unit: %

Parameters for setting and query:

<DiagramName> Name of the diagram on which the zoom area is based.
 <ZoomName> Name of the zoom diagram

LAYout:ZOOM:VERTical:RELative:STOP <DiagramName>,
 <ZoomName>,<RelativeStop>

LAYout:ZOOM:VERTical:RELative:STOP? <DiagramName>, <ZoomName>

Defines the upper limit of the zoom area on the y-axis.

Parameters:

<RelativeStop> Range: -100E+24 to 100E+24
 Increment: 0.1
 *RST: 100
 Default unit: %

Parameters for setting and query:

<DiagramName> Name of the diagram on which the zoom area is based.
 <ZoomName> Name of the zoom diagram

LAYout:ZOOM:REMOve <DiagramName>, <ZoomName>

Removes the specified zoom diagram.

Setting parameters:

<DiagramName> Name of the diagram on which the zoom area is based.
 <ZoomName> Name of the zoom diagram

Example: See [chapter 21.3.1.1, "Creating Zoom Diagrams"](#),
 on page 1127

Usage: Setting only

21.2.8.6 XY-Diagram

WAVeform<m>:XYCurve:RATio.....	769
WAVeform<m>:XYCurve:STATe.....	769
WAVeform<m>:XYCurve:SWAP.....	770
WAVeform<m>:XYCurve:XSource.....	770
WAVeform<m>:XYCurve:YSource.....	770

WAVeform<m>:XYCurve:RATio <ConstantXYRatio>

If enabled, the x- and y-axes maintain a constant ratio in the diagram.

Suffix:

<m> 1..4
 XY-diagram

Parameters:

<ConstantXYRatio> ON | OFF
 *RST: ON

WAVeform<m>:XYCurve:STATe <State>

Activates an XY-waveform.

Suffix:

<m> 1..4
 XY-diagram

Parameters:

<State> ON | OFF
 *RST: OFF

WAVeform<m>:XYCurve:SWAP

Replaces the source of the x-axis with the source of the y-axis and vice versa.

Suffix:

<m> 1..4
 XY-diagram

Usage: Event

WAVeform<m>:XYCurve:XSource <XYCurveXSource>

Defines the signal source that supplies the x-values of the XY-diagram.

Suffix:

<m> 1..4
 XY-diagram

Parameters:

<XYCurveXSource> NONE | C1W1 | C1W2 | C1W3 | C2W1 | C2W2 | C2W3 | C3W1 | C3W2 | C3W3 | C4W1 | C4W2 | C4W3 | M1 | M2 | M3 | M4 | R1 | R2 | R3 | R4
 Source of x-values, see [chapter 21.2.3.2, "Waveform Parameter"](#), on page 666
 *RST: NONE

WAVeform<m>:XYCurve:YSource <XYCurveYSource>

Defines the signal source that supplies the y-values of the XY-diagram.

Suffix:

<m> 1..4
 XY-diagram

Parameters:

<XYCurveYSource> NONE | C1W1 | C1W2 | C1W3 | C2W1 | C2W2 | C2W3 | C3W1 | C3W2 | C3W3 | C4W1 | C4W2 | C4W3 | M1 | M2 | M3 | M4 | R1 | R2 | R3 | R4
 Source of y-values, see [chapter 21.2.3.2, "Waveform Parameter"](#), on page 666
 *RST: NONE

21.2.8.7 History

CHANnel<m>[:WAVeform<n>]:HISTory[:STATe].....	771
ACQuire:AVAIlable?.....	771
CHANnel<m>[:WAVeform<n>]:HISTory:CURRent.....	771
CHANnel<m>[:WAVeform<n>]:HISTory:STARt.....	772
CHANnel<m>[:WAVeform<n>]:HISTory:STOP.....	772
CHANnel<m>[:WAVeform<n>]:HISTory:TPACq.....	773
CHANnel<m>[:WAVeform<n>]:HISTory:PLAY.....	773
CHANnel<m>[:WAVeform<n>]:HISTory:REPLay.....	773
CHANnel<m>[:WAVeform<n>]:HISTory:TSDate?.....	774
CHANnel<m>[:WAVeform<n>]:HISTory:TSABsolute?.....	774
CHANnel<m>[:WAVeform<n>]:HISTory:TSRelative?.....	774

CHANnel<m>[:WAVeform<n>]:HISTory[:STATe] <State>

Enables or disables the history display.

Suffix:

<m> 1..4

Selects the input channel.

<n> 1..3

Selects the waveform. For each channel, up to three waveforms can be analyzed. If WAVeform<n> is omitted, waveform 1 is addressed.

Parameters:

<State> ON | OFF

*RST: OFF

ACQuire:AVAIlable?

Returns the number of acquisitions currently saved in the memory. This number of acquisitions is available for history viewing. It is also the number of acquisitions in an Ultra Segmentation acquisition series.

Return values:

<AcqCount> Range: 0 to 4294967295

Usage: Query only

Firmware/Software: V 1.25

CHANnel<m>[:WAVeform<n>]:HISTory:CURRent <CurrAcqIdx>

Accesses a particular acquisition in the memory to display it. The query returns the index of the segment that is shown.

Suffix:

<m> 1..4

Selects the input channel.

<n> 1..3
 Selects the waveform. For each channel, up to three waveforms can be analyzed. If WAVEform<n> is omitted, waveform 1 is addressed.

Parameters:

<CurrAcqIdx> History index: the newest segment has the index "0", older segments have a negative index: -(n-1), -1 , 0
 where n is the number of acquired segments.
 Range: 0 to -(n-1)
 Increment: 1

CHANnel<m>[:WAVEform<n>]:HISTory:STARt <StartAcqIdx>

Sets the index of the oldest history acquisition for the history viewing.

Suffix:

<m> 1..4
 Selects the input channel.

<n> 1..3
 Selects the waveform. For each channel, up to three waveforms can be analyzed. If WAVEform<n> is omitted, waveform 1 is addressed.

Parameters:

<StartAcqIdx> The start index is always negative.
 Range: 0 to -(n-1)
 Increment: 1

CHANnel<m>[:WAVEform<n>]:HISTory:STOP <StopAcqIdx>

Sets the index of the latest segment to be displayed in the history viewer.

Suffix:

<m> 1..4
 Selects the input channel.

<n> 1..3
 Selects the waveform. For each channel, up to three waveforms can be analyzed. If WAVEform<n> is omitted, waveform 1 is addressed.

Parameters:

<StopAcqIdx> Index of the stop acquisition. The newest acquisition always has the index "0".
 Range: 0 to -(n-1)
 Increment: 1

CHANnel<m>[:WAVEform<n>]:HISTory:TPACq <TimePerAcq>

Sets the display time for one acquisition. The shorter the time, the faster is the replay.

Suffix:

<m> 1..4

Selects the input channel.

<n> 1..3

Selects the waveform. For each channel, up to three waveforms can be analyzed. If WAVEform<n> is omitted, waveform 1 is addressed.

Parameters:

<TimePerAcq> Range: 40E-6 to 10
Increment: 1
*RST: 0.05
Default unit: s

CHANnel<m>[:WAVEform<n>]:HISTory:PLAY

Starts and stops the replay of the history waveforms.

Suffix:

<m> 1..4

Selects the input channel.

<n> 1..3

Selects the waveform. For each channel, up to three waveforms can be analyzed. If WAVEform<n> is omitted, waveform 1 is addressed.

Usage:

Event
Asynchronous command

CHANnel<m>[:WAVEform<n>]:HISTory:REPLay <AutoRepeat>

If ON, the replay of the history waveform sequence repeats automatically. Otherwise, the replay stops at the stop index set with [CHANnel<m>\[:WAVEform<n>\]:HISTory:STOP](#).

Suffix:

<m> 1..4

Selects the input channel.

<n> 1..3

Selects the waveform. For each channel, up to three waveforms can be analyzed. If WAVEform<n> is omitted, waveform 1 is addressed.

Parameters:

<AutoRepeat> ON | OFF
*RST: OFF

Usage: Asynchronous command

CHANnel<m>[:WAVEform<n>]:HISTory:TSDate?

Returns the date of the current acquisition that is shown in the history viewer (CHANnel<m>[:WAVEform<n>]:HISTory:CURRENT).

Suffix:

<m> 1..4
Selects the input channel.

<n> 1..3
Selects the waveform. For each channel, up to three waveforms can be analyzed. If WAVEform<n> is omitted, waveform 1 is addressed.

Return values:

<DateAbsString> String with date of the current acquisition (absolute time)

Usage: Query only

CHANnel<m>[:WAVEform<n>]:HISTory:TSABsolute?

Returns the absolute daytime of the current acquisition that is shown in the history viewer (CHANnel<m>[:WAVEform<n>]:HISTory:CURRENT).

Suffix:

<m> 1..4
Selects the input channel.

<n> 1..3
Selects the waveform. For each channel, up to three waveforms can be analyzed. If WAVEform<n> is omitted, waveform 1 is addressed.

Return values:

<TimeAbsString> String containing the time and unit

Usage: Query only

CHANnel<m>[:WAVEform<n>]:HISTory:TSRelative?

Returns the relative time of the current acquisition - the time difference to the newest acquisition (index = 0).

See also: (CHANnel<m>[:WAVEform<n>]:HISTory:CURRENT).

Suffix:

<m> 1..4
Selects the input channel.

<n> 1..3
 Selects the waveform. For each channel, up to three waveforms can be analyzed. If WAVEform<n> is omitted, waveform 1 is addressed.

Return values:

<TimeRelative> Range: -100E+24 to 100E+24
 Default unit: s

Usage: Query only

21.2.9 Reference Waveforms

- [Reference](#).....775
- [Scaling](#).....777
- [Waveform Data](#).....781

21.2.9.1 Reference

REFCurve<m>:SOURce	775
REFCurve<m>:STATe	775
REFCurve<m>:NAME	776
REFCurve<m>:OPEN	776
REFCurve<m>:UPDate	776
REFCurve<m>:SAVE	776
REFCurve<m>:DELeTe	777
REFCurve<m>:CLEar	777
REFCurve<m>:RESTore	777

REFCurve<m>:SOURce <Source>

Selects the source waveform to be used as a reference.

Suffix:

<m> 1..4
 Reference waveform

Parameters:

<Source> C1W1 | C1W2 | C1W3 | C2W1 | C2W2 | C2W3 | C3W1 | C3W2 |
 C3W3 | C4W1 | C4W2 | C4W3 | M1 | M2 | M3 | M4 | R1 | R2 |
 R3 | R4
 Source of the reference waveform, see [chapter 21.2.3.2, "Waveform Parameter"](#), on page 666
 *RST: C1W1

REFCurve<m>:STATe <State>

If enabled, the reference waveform is displayed in the diagram.

Suffix:

<m> 1..4
Reference waveform

Parameters:

<State> ON | OFF
*RST: OFF

REFCurve<m>:NAME <Name>

Defines the name of the reference waveform file to be loaded, saved or deleted.

Suffix:

<m> 1..4
Reference waveform

Parameters:

<Name> Path and name of the file that contains the reference waveform or to which the reference waveform is to be stored (.xml or .bin format), enclosed in single quotes.

REFCurve<m>:OPEN

Loads the reference waveform file selected by [REFCurve<m>:NAME](#) on page 776.

Suffix:

<m> 1..4
Reference waveform

Usage: Event

REFCurve<m>:UPDATE

Copies the selected source waveform (see [REFCurve<m>:SOURCE](#) on page 775) with all its settings to the memory of the reference waveform.

Suffix:

<m> 1..4
Reference waveform

Usage: Event

REFCurve<m>:SAVE

Saves the reference waveform to the file selected by [REFCurve<m>:NAME](#) on page 776.

Suffix:

<m> 1..4
Reference waveform

Usage: Event

REFCurve<m>:DElete

Deletes the reference waveform file selected by [REFCurve<m>:NAME](#) on page 776.

Suffix:

<m> 1..4
Reference waveform

Usage: Event

REFCurve<m>:CLEar

The selected reference waveform is no longer displayed, its memory is deleted.

Suffix:

<m> 1..4
Reference waveform

Usage: Event

REFCurve<m>:RESTore

Restores the settings of the source waveform, if vertical scaling is set to "Independent" (see [REFCurve<m>:VMODE](#) on page 777).

Suffix:

<m> 1..4
Reference waveform

Usage: Event
SCPI confirmed

21.2.9.2 Scaling

REFCurve<m>:VMODE	777
REFCurve<m>:SCALE	778
REFCurve<m>:POSITION	778
REFCurve<m>:RESCale:VERTical:STATE	778
REFCurve<m>:RESCale:VERTical:FACTor	779
REFCurve<m>:RESCale:VERTical:OFFSet	779
REFCurve<m>:HMODE	779
REFCurve<m>:RESCale:HORizontal:STATE	780
REFCurve<m>:RESCale:HORizontal:FACTor	780
REFCurve<m>:RESCale:HORizontal:OFFSet	780

REFCurve<m>:VMODE <VerticalMode>

Selects the coupling of vertical settings.

Suffix:

<m> 1..4
Reference waveform

Parameters:

<VerticalMode> COUPlEd | INDePendent

COUPlEd

Vertical position and scale of the source are used.

INDePendent

Scaling and position can be set specific to the reference waveform.

*RST: INDePendent

REFCurve<m>:SCALE <VerticalScale>

Sets the scale factor for the reference waveform if vertical scaling is set to "Independent" (see [REFCurve<m>:VMODE](#) on page 777).

Suffix:

<m> 1..4
Reference waveform

Parameters:

<VerticalScale> Range: 1E-15 to 100E+24
Increment: 10E-6
*RST: 0.5
Default unit: V/div

Usage: SCPI confirmed

REFCurve<m>:POSition <VertPosi>

Moves the reference waveform and its horizontal axis up or down in the diagram, if vertical scaling is set to "Independent" (see [REFCurve<m>:VMODE](#) on page 777).

Suffix:

<m> 1..4
Reference waveform

Parameters:

<VertPosi> Range: -100E+24 to 100E+24
Increment: 0.2
*RST: 0
Default unit: div

Usage: SCPI confirmed

REFCurve<m>:RESCale:VERTical:STATe <State>

Enables and disables the vertical stretching. Stretching changes the display of the waveform independent of the vertical scale and position.

Suffix:

<m> 1..4
Reference waveform

Parameters:

<State> ON | OFF
 *RST: OFF

REFCurve<m>:RESCale:VERTical:FACTOR <ScaleFactor>

Defines the vertical stretching factor. A factor greater than 1 stretches the waveform vertically, a factor lower than 1 compresses the curve.

Suffix:

<m> 1..4
 Reference waveform

Parameters:

<ScaleFactor> Range: -1E+6 to 1E+6
 Increment: 0.1
 *RST: 1

REFCurve<m>:RESCale:VERTical:OFFSet <Offset>

Moves the reference waveform vertically. Like vertical offset of channel waveforms, the offset of a reference waveform is subtracted from the measured value.

Suffix:

<m> 1..4
 Reference waveform

Parameters:

<Offset> Negative values shift the waveform up, positive values shift it down.
 Range: -100E+24 to 100E+24
 Increment: 1E-6
 *RST: 0
 Default unit: V

REFCurve<m>:HMODe <HorizontalMode>

Selects the coupling of horizontal settings.

Suffix:

<m> 1..4
 Reference waveform

Parameters:

<HorizontalMode> ORIGINAL | COUPled

ORIGINAL

Horizontal scaling and reference point of the source waveform are used.

COUPled

The current horizontal settings of the diagram are used.

*RST: ORIGINAL

REFCurve<m>:RESCale:HORizontal:STATe <State>

Enables and disables the horizontal stretching.

Stretching changes the display of the waveform independent of the horizontal settings of the source waveform and of the horizontal diagram settings.

Suffix:

<m> 1..4
Reference waveform

Parameters:

<State> ON | OFF
*RST: OFF

REFCurve<m>:RESCale:HORizontal:FACTOR <ScaleFactor>

A factor greater than 1 stretches the waveform horizontally, a factor lower than 1 compresses the curve.

Suffix:

<m> 1..4
Reference waveform

Parameters:

<ScaleFactor> Range: 1E-6 to 1E+6
Increment: 0.1
*RST: 1

REFCurve<m>:RESCale:HORizontal:OFFSet <Offset>

Moves the waveform horizontally. Positive values shift the waveform to the right, negative values shift it to the left.

Suffix:

<m> 1..4
Reference waveform

Parameters:

<Offset> Range: -100E+24 to 100E+24
 Increment: 0.01
 *RST: 0
 Default unit: s

21.2.9.3 Waveform Data

REFCurve<m>:DATA:STYPe?..... 781
 REFCurve<m>:DATA:HEADer?..... 781
 REFCurve<m>:DATA[:VALues]?..... 782

REFCurve<m>:DATA:STYPe?

Returns the signal type of the source of the reference waveform.

Suffix:

<m> 1..4
 Reference waveform

Return values:

<SignalType> SOUR | SPEC | CORR | NONE
 SOURce = normal signal
 SPECtrum = FFT spectrum, specific math signal
 CORRelation = correlated signal, specific math signal
 NONE = undefined

Usage:

Query only
 SCPI confirmed

REFCurve<m>:DATA:HEADer?

Returns information on the reference waveform.

Table 21-14: Header data

Position	Meaning	Example
1	XStart in s	-9.477E-008 = - 94,77 ns
2	XStop in s	9.477E-008 = 94,77 ns
3	Record length of the waveform in Samples	200000
4	Number of values per sample interval. For reference waveforms the number is always 1.	1

Suffix:

<m> 1..4
 Reference waveform

Example:

REFC:DATA:HEAD?
 -9.477E-008,9.477E-008,200000,1

Usage: Query only
SCPI confirmed

REFCurve<m>:DATA[:VALues]?

Returns the data of the channel waveform points for transmission from the instrument to the controlling computer. The data can be used in MATLAB, for example.

To set the export format, use [FORMat \[:DATA\]](#).

You can retrieve only Y-values, or X- and Y-values. Use [EXPort:WAVeform:INCXvalues](#) to define this.

Suffix:
<m> 1..4
Reference waveform

Return values:
<Data> List of values according to the format and content settings.

Usage: Query only

21.2.10 Cursor Measurements

CURSor<m>:AOFF	782
CURSor<m>:STATe	783
CURSor<m>:FUNction	783
CURSor<m>:TRACking[:STATe]	783
CURSor<m>:SOURce	784
CURSor<m>:X1Position	784
CURSor<m>:X2Position	784
CURSor<m>:XCoupling	784
CURSor<m>:Y1Position	785
CURSor<m>:Y2Position	785
CURSor<m>:YCOupling	785
CURSor<m>:X1ENvelope	786
CURSor<m>:X2ENvelope	786
CURSor<m>:XDELta[:VALue]?	787
CURSor<m>:XDELta:INVerse?	787
CURSor<m>:YDELta[:VALue]?	787
CURSor<m>:YDELta:SLOPe	788
CURSor<m>:MAXimum[:PEAK]	788
CURSor<m>:MAXimum:LEFT	788
CURSor<m>:MAXimum:RIGHT	788
CURSor<m>:MAXimum:NEXT	788
CURSor<m>:PEXCursion	789

CURSor<m>:AOFF

This command switches all cursors off.

Suffix:
 <m> 1..4
 The numeric suffix is ignored.

Usage: Event

CURSor<m>:STATe <State>

Switches the indicated cursor on or off.

Suffix:
 <m> 1..4
 Selects the cursor.

Parameters:
 <State> ON | OFF
 *RST: OFF

CURSor<m>:FUNCTion <Type>

Defines the type of the indicated cursor.

Suffix:
 <m> 1..4
 Selects the cursor.

Parameters:
 <Type> HORizontal | VERTical | PAIRed

HORizontal
 A pair of horizontal cursor lines.

VERTical
 A pair of vertical cursor lines.

PAIRed
 Both vertical and horizontal cursor line pairs.

*RST: PAIRed

CURSor<m>:TRACking[:STATe] <TrackCurve>

If set to ON, the horizontal cursor lines follow the waveform.

Suffix:
 <m> 1..4
 Selects the cursor.

Parameters:
 <TrackCurve> ON | OFF
 *RST: OFF

CURSor<m>:SOURce <CursorSource>

Defines the source of the cursor measurement.

Suffix:

<m> 1..4
Selects the cursor.

Parameters:

<CursorSource> NONE | C1W1 | C1W2 | C1W3 | C2W1 | C2W2 | C2W3 | C3W1 | C3W2 | C3W3 | C4W1 | C4W2 | C4W3 | M1 | M2 | M3 | M4 | R1 | R2 | R3 | R4 | XY1 | XY2 | XY3 | XY4 | D0 | D1 | D2 | D3 | D4 | D5 | D6 | D7 | D8 | D9 | D10 | D11 | D12 | D13 | D14 | D15 | MSOB1 | MSOB2 | MSOB3 | MSOB4 | TRK1 | TRK2 | TRK3 | TRK4 | TRK5 | TRK6 | TRK7 | TRK8
Source of the cursor measurement, see [chapter 21.2.3.2, "Waveform Parameter"](#), on page 666
*RST: NONE

CURSor<m>:X1Position <XPosition1>

Defines the position of the left vertical cursor line.

Suffix:

<m> 1..4
Selects the cursor.

Parameters:

<XPosition1> Range: 0 to 500
Increment: 0.1
*RST: 0

CURSor<m>:X2Position <XPosition2>

Defines the position of the right vertical cursor line.

Suffix:

<m> 1..4
Selects the cursor.

Parameters:

<XPosition2> Range: 0 to 500
Increment: 0.1
*RST: 0
Default unit: s

CURSor<m>:XCOupling <Coupling>

Defines the positioning mode of the vertical cursor.

Suffix:

<m> 1..4
Selects the cursor.

Parameters:

<Coupling> ON | OFF
ON
Moving one cursor line moves the other cursor line too. The cursor lines always remain a fixed distance.
OFF
Each cursor line is positioned independently.
*RST: OFF

CURSOr<m>:Y1Position <YPosition1>

Defines the position of the lower horizontal cursor line.

If [CURSOr<m>:TRACking\[:STATe\]](#) is enabled, the query returns the measurement result - the lower vertical value of the waveform.

Suffix:

<m> 1..4
Cursor measurement

Parameters:

<YPosition1> Range: -50 to 50
Increment: 0.01
*RST: 0
Default unit: The unit depends on the type of the waveform.

CURSOr<m>:Y2Position <YPosition2>

Defines the position of the upper horizontal cursor line.

If [CURSOr<m>:TRACking\[:STATe\]](#) is enabled, the query returns the measurement result - the upper vertical value of the waveform.

Suffix:

<m> 1..4
Cursor measurement

Parameters:

<YPosition2> Range: -50 to 50
Increment: 0.01
*RST: 0
Default unit: The unit depends on the type of the waveform.

CURSOr<m>:YCOupling <Coupling>

Defines the positioning mode of the horizontal cursor. If the horizontal cursor lines track the waveform, the y-coupling is irrelevant ([CURSOr<m>:MODE TRACk](#)).

Suffix:

<m> 1..4
Selects the cursor.

Parameters:

<Coupling> ON | OFF

ON
Moving one cursor line moves the other cursor line too. The cursor lines always remain a fixed distance.

OFF
Each cursor line is positioned independently.

*RST: OFF

CURSOr<m>:X1ENvelope <EnvelopeCurve1>

If the waveform arithmetics are set to envelope curve (see [CHANnel<m>\[:WAVEform<n>\]:ARITHmetics](#) on page 683) and [CURSOr<m>:TRACking\[:STATe\]](#) is set to "ON", this setting defines how the first horizontal cursor is positioned.

Suffix:

<m> 1..4
math waveform

Parameters:

<EnvelopeCurve1> MIN | MAX

MIN
The horizontal cursor is set to the crossing point of the vertical cursor with the minimum waveform envelope.

MAX
The horizontal cursor is set to the crossing point of the vertical cursor with the maximum waveform envelope.

*RST: MAX

CURSOr<m>:X2ENvelope <EnvelopeCurve2>

If the waveform arithmetics are set to envelope curve (see [CHANnel<m>\[:WAVEform<n>\]:ARITHmetics](#) on page 683) and [CURSOr<m>:TRACking\[:STATe\]](#) is set to "ON", this setting defines how the second horizontal cursor is positioned.

Suffix:

<m> 1..4
math waveform

Parameters:

<EnvelopeCurve2> MIN | MAX

MIN

The horizontal cursor is set to the crossing point of the vertical cursor with the minimum waveform envelope.

MAX

The horizontal cursor is set to the crossing point of the vertical cursor with the maximum waveform envelope.

*RST: MIN

CURSor<m>:XDELta[:VALue]?

Queries the delta value (distance) of two vertical cursor lines.

Suffix:

<m> 1..4
Selects the cursor.

Return values:

<Delta> Range: -100E+24 to 100E+24
*RST: 0
Default unit: s

Usage: Query only**CURSor<m>:XDELta:INVerse?**

Queries the inverse value of the delta value (distance) of the two vertical cursor lines.

Suffix:

<m> 1..4
Selects the cursor.

Return values:

<DeltaInverse> Range: -100E+24 to 100E+24
*RST: 0
Default unit: Hz

Usage: Query only**CURSor<m>:YDELta[:VALue]?**

Queries the delta value (distance) of the two horizontal cursor lines.

Suffix:

<m> 1..4
Selects the cursor.

Return values:

<Delta> Range: -100E+24 to 100E+24
*RST: 0

Usage: Query only

CURSor<m>:YDELta:SLOPe <DeltaSlope>

Returns the inverse value of the voltage difference - the reciprocal of the vertical distance of two horizontal cursor lines: $1/\Delta V$.

Suffix:

<m> 1..4
Selects the cursor.

Parameters:

<DeltaSlope> Range: -100E+24 to 100E+24
Increment: 0
*RST: 0

CURSor<m>:MAXimum[:PEAK]

Sets both cursors to the absolute peak value.

Suffix:

<m> 1..4
Selects the cursor (set).

Usage: Event

CURSor<m>:MAXimum:LEFT

Sets cursor 2 to the next maximum to the left of the current position.

Suffix:

<m> 1..4
Selects the cursor.

Usage: Event

CURSor<m>:MAXimum:RIGHT

Sets cursor 2 to the next peak to the right (from the current position).

Suffix:

<m> 1..4
Selects the cursor (set).

Usage: Event

CURSor<m>:MAXimum:NEXT

Sets cursor 2 to the next smaller peak (from the current position).

Suffix:	
<m>	1..4 Selects the cursor (set).
Usage:	Event

CURSor<m>:PEXCursion <PeakExcursion>

Defines the minimum level by which the waveform must rise or fall so that it will be identified as a maximum or a minimum by the search functions.

Suffix:	
<m>	1..4 irrelevant

Parameters:	
<PeakExcursion>	Range: 0 to 100 Increment: 1 *RST: 5 Default unit: dB

21.2.11 Automatic Measurements

This chapter contains all remote commands to set up automatic measurements and to analyze the measurement results.

Measurement selection: MEASurement<m>

With R&S RTO you can configure up to eight simultaneous measurements, and each can include several measurement types. For manual operation, these eight measurements are represented as tabs "Meas 1" to "Meas 8" in the "Measurements" dialog box. For remote operation, the measurement is indicated by the suffix <m>, containing the number of the measurement.

Only for remote operation in Tektronix emulation mode ([SYSTem:LANGuage](#) on page 675), an additional measurement with suffix number 9 is available for Tektronix' immediate measurements.

• General Settings	790
• Reference Level	796
• Amplitude/Time Measurement	810
• Eye Diagram Measurements	819
• Spectrum	821
• Histograms	825
• Display	834
• Limit check	835
• Statistics and Long-term Measurements	835
• Track and Trend	840
• Results	841
• Gating	843
• Event Actions	845

21.2.11.1 General Settings

MEASurement<m>[:ENABLE].....	790
MEASurement<m>:SOURce.....	790
MEASurement<m>:FSRC.....	791
MEASurement<m>:SSRC.....	791
MEASurement<m>:CATegory.....	792
MEASurement<m>:MAIN.....	792
MEASurement<m>:ADditiOnal.....	794
MEASurement<m>:AON.....	795
MEASurement<m>:AOFF.....	795
MEASurement<m>:CLEar.....	796
MEASurement<m>:MULTiple.....	796
MEASurement<m>:MNOMeas.....	796

MEASurement<m>[:ENABLE] <State>

Switches the indicated measurement on or off.

Suffix:

<m> 1..9
See "[Measurement selection: MEASurement<m>](#)" on page 789.

Parameters:

<State> ON | OFF
*RST: OFF

MEASurement<m>:SOURce <SignalSource>, [<SignalSource2>]

Defines the source of the measurement. Depending on the selected source type, only suitable measurement types are available.

Suffix:

<m> 1..9
See "[Measurement selection: MEASurement<m>](#)" on page 789.

Parameters:

<SignalSource> C1W1 | C1W2 | C1W3 | C2W1 | C2W2 | C2W3 | C3W1 | C3W2 |
C3W3 | C4W1 | C4W2 | C4W3 | M1 | M2 | M3 | M4 | R1 | R2 |
R3 | R4 | SBUS1 | SBUS2 | SBUS3 | SBUS4 | D0 | D1 | D2 |
D3 | D4 | D5 | D6 | D7 | D8 | D9 | D10 | D11 | D12 | D13 | D14 |
D15 | TRK1 | TRK2 | TRK3 | TRK4 | TRK5 | TRK6 | TRK7 |
TRK8

Source of the measurement, see [chapter 21.2.3.2, "Waveform Parameter"](#), on page 666

Digital channels are provided with option R&S RTO-B1.

Serial bus is available as measurement source if an audio bus is configured (option R&S RTO-K5)

<SignalSource2> C1W1 | C1W2 | C1W3 | C2W1 | C2W2 | C2W3 | C3W1 | C3W2 | C3W3 | C4W1 | C4W2 | C4W3 | M1 | M2 | M3 | M4 | R1 | R2 | R3 | R4 | D0 | D1 | D2 | D3 | D4 | D5 | D6 | D7 | D8 | D9 | D10 | D11 | D12 | D13 | D14 | D15 | TRK1 | TRK2 | TRK3 | TRK4 | TRK5 | TRK6 | TRK7 | TRK8

Digital channels are only available if <SignalSource> is a digital channel.

MEASurement<m>:FSRC <MeasSrc>

Defines the first measurement source.

the command is an alternative to [MEASurement<m>:SOURCE](#).

Suffix:

<m> 1..9
See "[Measurement selection: MEASurement<m>](#)" on page 789.

Parameters:

<MeasSrc> C1W1 | C1W2 | C1W3 | C2W1 | C2W2 | C2W3 | C3W1 | C3W2 | C3W3 | C4W1 | C4W2 | C4W3 | M1 | M2 | M3 | M4 | R1 | R2 | R3 | R4 | SBUS1 | SBUS2 | SBUS3 | SBUS4 | D0 | D1 | D2 | D3 | D4 | D5 | D6 | D7 | D8 | D9 | D10 | D11 | D12 | D13 | D14 | D15 | TRK1 | TRK2 | TRK3 | TRK4 | TRK5 | TRK6 | TRK7 | TRK8

Source of the measurement, see [chapter 21.2.3.2, "Waveform Parameter"](#), on page 666

SBUS1 ... SBUS4

Serial bus is available as measurement source if an audio bus is configured (option R&S RTO-K5)

D0 ... D15

Digital channels are provided with option R&S RTO-B1.

Firmware/Software: V 2.00

MEASurement<m>:SSRC <MeasSource2>

Defines the second measurement source.

the command is an alternative to [MEASurement<m>:SOURCE](#).

Suffix:

<m> 1..9
See "[Measurement selection: MEASurement<m>](#)" on page 789.

Parameters:

<MeasSource2> C1W1 | C1W2 | C1W3 | C2W1 | C2W2 | C2W3 | C3W1 | C3W2 | C3W3 | C4W1 | C4W2 | C4W3 | M1 | M2 | M3 | M4 | R1 | R2 | R3 | R4 | D0 | D1 | D2 | D3 | D4 | D5 | D6 | D7 | D8 | D9 | D10 | D11 | D12 | D13 | D14 | D15 | TRK1 | TRK2 | TRK3 | TRK4 | TRK5 | TRK6 | TRK7 | TRK8

Second source of the measurement, see [chapter 21.2.3.2, "Waveform Parameter"](#), on page 666

Digital channels are only available if a digital channel is set as first measurement source using `MEASurement<m>:FSRC`.

Firmware/Software: V 2.00

MEASurement<m>:CATegory <Category>

Defines the measurement category.

Suffix:

<m> 1..9
See "[Measurement selection: MEASurement<m>](#)" on page 789.

Parameters:

<Category> AMPTime | JITTer | EYEJitter | SPECtrum | HISTogram | PROTOcol

AMPTime
Amplitude and time measurements

JITTer
Jitter measurements, only available isf option R&S RTO-K12 is installed

EYEJitter
Eye diagram measurements

SPECtrum
Spectrum measurements

HISTogram
Histogram measurements

PROTOcol
Protocol measurements (track and trend)

*RST: AMPTime

Example: See "[Creating and Reading Histograms](#)" on page 1129

MEASurement<m>:MAIN <MeasType>

Defines or queries the main measurement. This measurement is the one referred to if the measurement waveform is used as a source for math calculations. The main measurement type must belong to the same category as the other types assigned to the same measurement waveform, if there are any.

For details on the measurement types and categories, see [chapter 7.2.1, "Measurements, Measurement Types, and Results"](#), on page 230.

Suffix:

<m>

1..9

See "[Measurement selection: MEASurement<m>](#)" on page 789.**Parameters:**

<MeasType>

Amplitude/time measurements

HIGH | LOW | AMPLitude | MAXimum | MINimum | PDELta | MEAN | RMS | STDDev | POVershoot | NOVershoot | AREA | RTIME | FTIME | PPULse | NPULse | PERiod | FREQuency | PDCYcle | NDCYcle | CYCarea | CYCMean | CYCRms | CYCStddev | PULCnt | DELay | PHASe | BWIDth | PSWitching | NSWitching | PULSetrain | EDGecount | SHT | SHR | DTOTrigger | PROBemeter

See [chapter 21.2.11.3, "Amplitude/Time Measurement"](#), on page 810.

*RST value for amplitude/time measurements: AMPLitude.

Jitter measurements

CCJitter | NCJitter | CCWidth | CCDutycycle | TIE | UINterval | DRATe | SKWDelay | SKWPhase

Only available if option R&S RTO-K12 is installed. See [chapter 21.2.20.1, "Jitter Measurements \(Option R&S RTO-K12\)"](#), on page 1075.

Eye diagram measurements

ERPercent | ERDB | EHEight | EWIDth | ETOP | EBASe | QFACTor | RMSNoise | SNRatio | DCDistortion | ERTIME | EFTIME | EBRate | EAMPLitude | PPJitter | STDJitter | RMSJitter

See [chapter 21.2.11.4, "Eye Diagram Measurements"](#), on page 819.

*RST value for eye/jitter measurements: ERPercent.

Spectrum measurements

CPOWer | OBWidth | SBWidth | THD | HAR

See [chapter 21.2.11.5, "Spectrum"](#), on page 821.

*RST value spectrum measurements: CPOWer.

Histogram measurements

WCOunt | WSAMples | HSAMples | HPEak | PEAK | UPEak-value | LPEakvalue | HMAXimum | HMINimum | MEDian | MAX-Min | HMEan | HSTDdev | M1STDdev | M2STDdev | M3STDdev | MKPositive | MKNegative

See "[Histogram Measurement](#)" on page 830.

*RST value for histogram measurements: WCOunt.

Example:

See "[Creating and Reading Histograms](#)" on page 1129

MEASurement<m>:ADDITIONal <MeasType>, <State>

MEASurement<m>:ADDITIONal? <MeasType>

Enables or disables an additional measurement. Only one measurement type can be enabled or disabled per command. The query returns the state of the specified measurement type.

Note that each measurement waveform can only perform measurements from the same category. For example, if you enable an amplitude measurement for measurement waveform 1, then you cannot enable an eye width measurement for the same waveform.

For details on the measurement types and categories, see [chapter 7.2.1, "Measurements, Measurement Types, and Results"](#), on page 230.

Suffix:

<m>

1..9

See "[Measurement selection: MEASurement<m>](#)" on page 789.

Parameters:

<State>

ON | OFF

Enables or disables the measurement type.

Parameters for setting and query:

<MeasType>

Amplitude/time measurements

HIGH | LOW | AMPLitude | MAXimum | MINimum | PDELta | MEAN | RMS | STDDev | POVershoot | NOVershoot | AREA | RTIME | FTIME | PPULse | NPULse | PERiod | FREQuency | PDCYcle | NDCYcle | CYCarea | CYCMean | CYCRms | CYCStddev | PULCnt | DELay | PHASe | BWIDth | PSWitching | NSWitching | PULSetrain | EDGecount | SHT | SHR | DTOTrigger | PROBemeter

See [chapter 21.2.11.3, "Amplitude/Time Measurement"](#), on page 810.

Jitter measurements

CCJitter | NCJitter | CCWidth | CCDutycycle | TIE | UINterval | DRATE | SKWDelay | SKWPhase

Only available if option R&S RTO-K12 is installed. See [chapter 21.2.20.1, "Jitter Measurements \(Option R&S RTO-K12\)"](#), on page 1075.

Eye diagram measurements

ERPercent | ERDB | EHEight | EWIDth | ETOP | EBASe | QFACTor | RMSNoise | SNRatio | DCDistortion | ERTIME | EFTIME | EBRate | EAMPLitude | PPJitter | STDJitter | RMSJitter

See [chapter 21.2.11.4, "Eye Diagram Measurements"](#), on page 819.

Spectrum measurements

CPOWER | OBWidth | SBWidth | THD | HAR

See [chapter 21.2.11.5, "Spectrum"](#), on page 821.

Histogram measurements

WCOunt | WSAMples | HSAMples | HPEak | PEAK | UPEakvalue | LPEakvalue | HMAXimum | HMINimum | MEDian | MAXMin | HMEan | HSTDdev | M1STDdev | M2STDdev | M3STDdev | MKPositive | MKNegative

See ["Histogram Measurement"](#) on page 830.

MEASurement<m>:AON

Enables all additional measurements in all categories of the indicated measurement.

Suffix:

<m> 1..9

See ["Measurement selection: MEASurement<m>"](#) on page 789.

Usage: Event

MEASurement<m>:AOFF

Disables all additional measurements in all categories of the indicated measurement.

Suffix:
 <m> 1..9
 See "Measurement selection: MEASurement<m>" on page 789.

Usage: Event

MEASurement<m>:CLEar

Deletes the statistic results of the indicated measurement.

Suffix:
 <m> 1..9
 See "Measurement selection: MEASurement<m>" on page 789.

Usage: Event

MEASurement<m>:MULTiple <MultiMeas>

The measurement is performed repeatedly if the measured parameter occurs several times inside the defined gate.

Suffix:
 <m> 1..9
 See "Measurement selection: MEASurement<m>" on page 789.

Parameters:
 <MultiMeas> ON | OFF
 *RST: OFF

MEASurement<m>:MNOMeas <MaxNoOfMeas>

Sets the maximum number of measurements per acquisition if multiple measurement is enabled (MEASurement<m>:MULTiple is ON).

Suffix:
 <m> 1..9
 See "Measurement selection: MEASurement<m>" on page 789.

Parameters:
 <MaxNoOfMeas> Range: 2 to 1000000
 Increment: 1
 *RST: 1000

21.2.11.2 Reference Level

- [General Reference Level Settings](#)..... 797
- [Automatic Configuration](#).....799
- [Manual Configuration](#).....801
- [Hysteresis](#)..... 806
- [Tube](#).....806
- [Results](#)..... 809

General Reference Level Settings

REFLevel<m>:LDETection	797
REFLevel<m>:RELative:MODE	797
REFLevel<m>:USRLevel	798
REFLevel<m>:LMODE	799

REFLevel<m>:LDETection <LevelDetection>

Defines whether the reference level is configured manually or automatically.

For automatic configuration, select the signal level to be used (see [REFLevel<m>:AUTO:MODE](#) on page 799).

Suffix:

<m> 2..21
Source waveform, see [chapter 21.2.3.1, "Waveform Suffix"](#), on page 665.

Parameters:

<LevelDetection> AUTO | MANual
*RST: AUTO

Example:

```
REFLevel2:LDETection MANual
```

Sets manual level configuration for Channel1/Waveform1. C1W1 corresponds to suffix number 2.

Example:

See: [chapter 21.3.2.1, "Setting Reference Levels"](#), on page 1128

REFLevel<m>:RELative:MODE <RelativeLevels>

The lower, middle and upper reference levels, defined as percentages of the high signal level.

Suffix:

<m> 2..21
Source waveform, see [chapter 21.2.3.1, "Waveform Suffix"](#), on page 665.

Parameters:

<RelativeLevels> FIVE | TEN | TWENTY | USER

FIVE

5/50/95

TEN

10/50/90

TWENTY

20/50/80

USER

Set the reference levels to individual values with

[REFLevel<m>:RELative:LOWer](#), [REFLevel<m>:RELative:MIDDLE](#), and [REFLevel<m>:RELative:UPPer](#).

*RST: TEN

Example:

REFL2:REL:MODE FIVE

Reference levels for Channel1/Waveform1: Lower reference level = 5% of high signal level, middle reference level = 50% of high signal level, upper reference level = 95% of high signal level

Example:

See: "[Manual reference level definition using relative values](#)" on page 1128

Usage:

SCPI confirmed

REFLevel<m>:USRLevel <UserLevel>

Defines whether the user-defined signal levels or user-defined reference levels are used for the measurements.

Suffix:

<m>

2..21

Source waveform, see [chapter 21.2.3.1, "Waveform Suffix"](#), on page 665.

Parameters:

<UserLevel> USIGNal | UREF

USIGNal

The high and low signal levels are defined by the user.

UREF

The reference levels are defined by the user.

*RST: USIGNal

Example:

REFLevel2:USRLevel UREF

Sets user-defined reference levels to be used for Channel1/Waveform1. C1W1 corresponds to suffix number 2.

Example:

See: "[Manual reference level definition using absolute values](#)" on page 1128

REFLevel<m>:LMODe <LevelMode>

Defines whether the reference is configured using absolute or relative values.

Suffix:

<m> 2..21
Source waveform, see [chapter 21.2.3.1, "Waveform Suffix"](#), on page 665.

Parameters:

<LevelMode> ABS | REL
*RST: REL

Example:

REFLevel12:LMODe ABS
Sets definition of reference levels to absolute values for Channel1/Waveform1. C1W1 corresponds to suffix number 2.

Example:

See: "[Manual reference level definition using relative values](#)" on page 1128

Automatic Configuration

REFLevel<m>:AUTO:MODE	799
REFLevel<m>:AUTO[:STATe]	800
REFLevel<m>:AUTO:COUNT	801

REFLevel<m>:AUTO:MODE <AutoLevelMode>

Defines the high and low signal levels from which the reference levels are derived.

This setting is only available for automatic reference level mode (see [REFLevel<m>:LDETection](#) on page 797).

Suffix:

<m> 1..67
Source waveform, see [chapter 21.2.3.1, "Waveform Suffix"](#), on page 665.

Parameters:

<AutoLevelMode>	AUTO PPRobability MPRobability ABSolutepeak UPLM UMLP UALM
	AUTO Auto select absolute probability: most suitable signal levels for the selected measurement
	PPRobability Peak probability: signal levels with the highest probability value
	MPRobability Mean probability: signal levels with mean probability
	ABSolutepeak Absolute peak: absolute peak signal levels
	UPLM Upper absolute peak, lower mean probability: high signal level is the upper absolute peak, low signal level is the level with the mean probability in the lower half of the histogram.
	UMLP Upper mean probability, lower absolute peak: high signal level is the level with mean probability in the upper half of the histogram, low signal level is the lower absolute peak.
	UALM Upper absolute peak, lower manual value: high signal level is the maximum result value of the amplitude measurement; low signal level is manually set using REFLevel<m>:RELative:LOWer .
	*RST: AUTO
Example:	<code>REFLevel15:AUTO:MODE PPRobability</code> Sets the automatic reference level mode for Channel2/Waveform1 to "Peak probability". C2W1 corresponds to suffix number 5.
Example:	See: " Automatic level detection, peak probability " on page 1128
Usage:	SCPI confirmed

REFLevel<m>:AUTO[:STATe] <HistgAveraging>

Enables averaging over several histograms to determine the reference levels. The number of histograms to consider is defined using [REFLevel<m>:AUTO:COUNT](#).

This function is only available in automatic reference level mode (see [REFLevel<m>:LDEtection](#) on page 797).

Suffix:

<m>	2..21 Source waveform, see chapter 21.2.3.1, "Waveform Suffix" , on page 665.
------------------	--

Parameters:

<HistgAveraging> ON | OFF
 *RST: OFF

Usage: SCPI confirmed

REFLevel<m>:AUTO:COUNT <Weight>

Defines the number of histograms to calculate the average from if [REFLevel<m>:AUTO\[:STATe\]](#) is set to ON.

This function is only available in automatic reference level mode (see [REFLevel<m>:LDEtection](#) on page 797).

Suffix:

<m> 2..21
 Source waveform, see [chapter 21.2.3.1, "Waveform Suffix"](#), on page 665.

Parameters:

<Weight> Range: 2 to 128
 Increment: 2
 *RST: 128

Usage: SCPI confirmed

Manual Configuration

- [User Signal Level](#).....801
- [User Reference Level](#).....803

User Signal Level

[REFLevel<m>:ABSolute:HIGH](#).....801
[REFLevel<m>:ABSolute:LOW](#).....802
[REFLevel<m>:ABSolute:TDistance](#).....802
[REFLevel<m>:ABSolute:BDistance](#).....803

REFLevel<m>:ABSolute:HIGH <SignalHigh>

The signal value that represents a high level.

Suffix:

<m> 2..21
 Source waveform, see [chapter 21.2.3.1, "Waveform Suffix"](#), on page 665.

Parameters:

<SignalHigh> Range: -100E+24 to 100E+24
 Increment: 1E-3
 *RST: 0
 Default unit: V

Example: REFLevel2:ABSolute:HIGH 0.015
Sets the high signal level for Channel1/Waveform1 to 15 mV. C1W1 corresponds to suffix number 2.

Usage: SCPI confirmed

REFLevel<m>:ABSolute:LOW <SignalLow>

The signal value that represents a low level.

Suffix:
<m> 2..21
Source waveform, see [chapter 21.2.3.1, "Waveform Suffix"](#), on page 665.

Parameters:
<SignalLow> Range: -100E+24 to 100E+24
Increment: 1E-3
*RST: 0
Default unit: V

Example: REFLevel2:ABSolute:Low 0.0015
Sets the low signal level for Channel1/Waveform1 to 1.5 mV. C1W1 corresponds to suffix number 2.

Usage: SCPI confirmed

REFLevel<m>:ABSolute:TDISTance <TopDistance>

The distance between the high signal level and the upper reference level.

Suffix:
<m> 2..21
Source waveform, see [chapter 21.2.3.1, "Waveform Suffix"](#), on page 665.

Parameters:
<TopDistance> Range: 0 to 100E+24
Increment: 1E-3
*RST: 0
Default unit: V

Example: REFLevel2:ABSolute:TDISTance 0.0002
Sets the top distance for Channel1/Waveform1 to 0.2 mV. C1W1 corresponds to suffix number 2.

Example: See: ["Manual reference level definition using absolute values"](#) on page 1128

Usage: SCPI confirmed

REFLevel<m>:ABSolute:BDIStance <BottomDistance>

The distance between the lower reference level and the low signal value.

Suffix:

<m> 2..21
Source waveform, see [chapter 21.2.3.1, "Waveform Suffix"](#), on page 665.

Parameters:

<BottomDistance> Range: 0 to 100E+24
Increment: 1E-3
*RST: 0
Default unit: V

Example:

REFLevel2:ABSolute:BDIStance 0.0002
Sets the bottom distance for Channel1/Waveform1 to 0.2 mV. C1W1 corresponds to suffix number 2.

Example:

See: "[Manual reference level definition using absolute values](#)" on page 1128

Usage:

SCPI confirmed

User Reference Level

REFLevel<m>:ABSolute:ULEVel	803
REFLevel<m>:ABSolute:MLEVEL	804
REFLevel<m>:ABSolute:LLEVEL	804
REFLevel<m>:RELative:UPPer	805
REFLevel<m>:RELative:MIDDLE	805
REFLevel<m>:RELative:LOWer	806

REFLevel<m>:ABSolute:ULEVel <UpperLevel>

The upper reference level, required e.g. to determine a rise.

Suffix:

<m> 2..21
Source waveform, see [chapter 21.2.3.1, "Waveform Suffix"](#), on page 665.

Parameters:

<UpperLevel> Range: -100E+24 to 100E+24
Increment: 1E-3
*RST: 0
Default unit: V

Example:

REFLevel2:ABSolute:ULEVel 0.01
Sets the upper reference level for Channel1/Waveform1 to 10 mV. C1W1 corresponds to suffix number 2.

Example:

See: "[Manual reference level definition using absolute values](#)" on page 1128

Usage: SCPI confirmed

REFLevel<m>:ABSolute:MLEVel <MiddleLevel>

The middle reference level.

Suffix:

<m> 2..21
Source waveform, see [chapter 21.2.3.1, "Waveform Suffix"](#), on page 665.

Parameters:

<MiddleLevel> Range: -100E+24 to 100E+24
Increment: 1E-3
*RST: 0
Default unit: V

Example: REFLevel2:ABSolute:MLEVel 0.005
Sets the middle reference level for Channel1/Waveform1 to 5 mV. C1W1 corresponds to suffix number 2.

Example: See: ["Manual reference level definition using absolute values"](#) on page 1128

Usage: SCPI confirmed

REFLevel<m>:ABSolute:LLEVel <LowerLevel>

The lower reference level, required e.g. to determine a fall.

Suffix:

<m> 2..21
Source waveform, see [chapter 21.2.3.1, "Waveform Suffix"](#), on page 665.

Parameters:

<LowerLevel> Range: -100E+24 to 100E+24
Increment: 1E-3
*RST: 0
Default unit: V

Example: REFLevel2:ABSolute:LLEVel 0.001
Sets the lower reference level for Channel1/Waveform1 to 1 mV. C1W1 corresponds to suffix number 2.

Example: See: ["Manual reference level definition using absolute values"](#) on page 1128

Usage: SCPI confirmed

REFLevel<m>:RELative:UPPer <UppRefLevRel>

Sets the upper relative reference level if `REFLevel<m>:RELative:MODE` is set to `USER`.

Suffix:

<m> 2..21
Source waveform, see [chapter 21.2.3.1, "Waveform Suffix"](#), on page 665.

Parameters:

<UppRefLevRel> Percentage of the high signal level.
Range: 0 to 100
Increment: 1
*RST: 90
Default unit: %

Example: `REFLevel8:RELative:LOWer 85`
Sets the upper reference level for Channel3/Waveform1 to 85%. C3W1 corresponds to suffix number 8.

Example: See: ["Manual reference level definition using relative values"](#) on page 1128

Usage: SCPI confirmed

REFLevel<m>:RELative:MIDDle <MiddleRefLevRel>

Sets the middle relative reference level if `REFLevel<m>:RELative:MODE` is set to `USER`.

Suffix:

<m> 2..21
Source waveform, see [chapter 21.2.3.1, "Waveform Suffix"](#), on page 665.

Parameters:

<MiddleRefLevRel> Percentage of the high signal level.
Range: 0 to 100
Increment: 1
*RST: 50
Default unit: %

Example: `REFLevel8:RELative:MIDDle 50`
Sets the middle reference level for Channel3/Waveform1 to 50%. C3W1 corresponds to suffix number 8.

Example: See: ["Manual reference level definition using relative values"](#) on page 1128

Usage: SCPI confirmed

REFLevel<m>:RELative:LOWer <LowRefLevRel>

Sets the lower relative reference level if [REFLevel<m>:RELative:MODE](#) is set to USER.

Suffix:

<m> 2..21
Source waveform, see [chapter 21.2.3.1, "Waveform Suffix"](#), on page 665.

Parameters:

<LowRefLevRel> Percentage of the high signal level.
Range: 0 to 100
Increment: 1
*RST: 10
Default unit: %

Example:

REFLevel8:RELative:LOWer 15
Sets the lower reference level for Channel3/Waveform1 to 15 %. C3W1 corresponds to suffix number 8.

Example:

See: ["Manual reference level definition using relative values"](#) on page 1128

Usage:

SCPI confirmed

Hysteresis**REFLevel<m>:RELative:HYSTeresis <Hysteresis>**

Defines a hysteresis for the middle reference level. A rise or fall from the middle reference value that does not exceed the hysteresis is rejected as noise.

Suffix:

<m> 2..21
Source waveform, see [chapter 21.2.3.1, "Waveform Suffix"](#), on page 665.

Parameters:

<Hysteresis> Range: 0 to 50
Increment: 1
*RST: 5
Default unit: %

Tube

REFLevel<m>:RELative:OTUBe	807
REFLevel<m>:RELative:ITUBe	807
REFLevel<m>:ABSolute:TOTube	807
REFLevel<m>:ABSolute:TITube	808
REFLevel<m>:ABSolute:BITube	808
REFLevel<m>:ABSolute:BOTube	808

REFLevel<m>:RELative:OTUBe <RelOuterDist>

Defines a percentage of the signal level by which the absolute signal level may be larger than the high signal level or lower than the low signal level to be considered high or low, respectively.

Suffix:

<m> 2..21
Source waveform, see [chapter 21.2.3.1, "Waveform Suffix"](#), on page 665.

Parameters:

<RelOuterDist> Range: 0 to 100
Increment: 1
*RST: 10
Default unit: %

Usage: SCPI confirmed

REFLevel<m>:RELative:ITUBe <RelativeInnDist>

Defines a percentage of the signal level by which the absolute signal level may be higher than the low signal level or lower than the high signal level to be considered low or high, respectively.

Suffix:

<m> 2..21
Source waveform, see [chapter 21.2.3.1, "Waveform Suffix"](#), on page 665.

Parameters:

<RelativeInnDist> Range: 0 to 50
Increment: 1
*RST: 0
Default unit: %

Usage: SCPI confirmed

REFLevel<m>:ABSolute:TOTube <TopOuterDist>

Defines an area above the high signal level which is still considered to be high level.

Suffix:

<m> 2..21
Source waveform, see [chapter 21.2.3.1, "Waveform Suffix"](#), on page 665.

Parameters:

<TopOuterDist> Range: 0 to 100E+24
Increment: 1E-3
*RST: 0
Default unit: V

Usage: SCPI confirmed

REFLevel<m>:ABSolute:TITube <TopInnerDist>

Defines an area beneath the high signal level which is still considered to be high level.

Suffix:

<m> 2..21
Source waveform, see [chapter 21.2.3.1, "Waveform Suffix"](#), on page 665.

Parameters:

<TopInnerDist> Range: 0 to 100E+24
Increment: 1E-3
*RST: 0
Default unit: V

Usage: SCPI confirmed

REFLevel<m>:ABSolute:BITube <BottomInnerDist>

Defines an area above the low signal level which is still considered to be low level.

Suffix:

<m> 2..21
Source waveform, see [chapter 21.2.3.1, "Waveform Suffix"](#), on page 665.

Parameters:

<BottomInnerDist> Range: 0 to 100E+24
Increment: 1E-3
*RST: 0
Default unit: V

Usage: SCPI confirmed

REFLevel<m>:ABSolute:BOTube <BottomOuterDist>

Defines an area beneath the low signal level which is still considered to be low level.

Suffix:

<m> 2..21
Source waveform, see [chapter 21.2.3.1, "Waveform Suffix"](#), on page 665.

Parameters:

<BottomOuterDist> Range: 0 to 100E+24
Increment: 1E-3
*RST: 0
Default unit: V

Usage: SCPI confirmed

Results

MEASurement<m>:REFLevel:RESult:LOWer?	809
MEASurement<m>:REFLevel:RESult:MIDDLE?	809
MEASurement<m>:REFLevel:RESult:UPPer?	809
MEASurement<m>:REFLevel:RESult:SIGLow?	809
MEASurement<m>:REFLevel:RESult:SIGHigh?	809
MEASurement<m>:REFLevel:RESult:BINNer?	809
MEASurement<m>:REFLevel:RESult:BOUter?	810
MEASurement<m>:REFLevel:RESult:TINNer?	810
MEASurement<m>:REFLevel:RESult:TOUTer?	810

MEASurement<m>:REFLevel:RESult:LOWer?**MEASurement<m>:REFLevel:RESult:MIDDLE?****MEASurement<m>:REFLevel:RESult:UPPer?**

Return the lower, middle, and upper reference level, respectively.

Suffix:

<m> 1..9

See "[Measurement selection: MEASurement<m>](#)" on page 789.

Return values:

<Level> Range: -100E+24 to 100E+24
*RST: 0

Usage: Query only

MEASurement<m>:REFLevel:RESult:SIGLow?**MEASurement<m>:REFLevel:RESult:SIGHigh?**

Return the signal value that represents a low or high level, respectively.

Suffix:

<m> 1..9

See "[Measurement selection: MEASurement<m>](#)" on page 789.

Return values:

<Level> Range: -100E+24 to 100E+24
*RST: 0

Usage: Query only

MEASurement<m>:REFLevel:RESult:BINNer?

Returns the area above the low signal level which is still considered to be low level.

Suffix:

<m> 1..9

See "[Measurement selection: MEASurement<m>](#)" on page 789.

Return values:

<BottomInner> Range: -100E+24 to 100E+24
*RST: 0

Usage: Query only

MEASurement<m>:REFLevel:RESult:BOUter?

Returns the area beneath the low signal level which is still considered to be low level.

Suffix:

<m> 1..9

See "[Measurement selection: MEASurement<m>](#)" on page 789.

Return values:

<BottomOuter> Range: -100E+24 to 100E+24
*RST: 0

Usage: Query only

MEASurement<m>:REFLevel:RESult:TINner?

Returns the area beneath the high signal level which is still considered to be high level.

Suffix:

<m> 1..9

See "[Measurement selection: MEASurement<m>](#)" on page 789.

Return values:

<TopInner> Range: -100E+24 to 100E+24
*RST: 0

Usage: Query only

MEASurement<m>:REFLevel:RESult:TOUTer?

Returns the area above the high signal level which is still considered to be high level.

Suffix:

<m> 1..9

See "[Measurement selection: MEASurement<m>](#)" on page 789.

Return values:

<TopOuter> Range: -100E+24 to 100E+24
*RST: 0

Usage: Query only

21.2.11.3 Amplitude/Time Measurement

The following table lists the measurement suffixes and the <MeasType> parameter value with a short description.

For a detailed description, see [chapter 7.2.1.2, "Amplitude/Time Measurements"](#), on page 234.

Table 21-15: Amplitude and time measurement types

Meas. suffix	<MeasType> parameter value	Meas. type	Description/Result
1	HIGH	High	High signal level
2	LOW	Low	Low signal level
3	AMPLitude	Amplitude	Amplitude of the signal
4	MAXimum	Max	Maximum value of the waveform
5	MINimum	Min	Minimum value of the waveform
6	PDELta	Peak to peak	Peak-to-peak value of the waveform
7	MEAN	Mean	Mean value of the waveform
8	RMS	RMS	RMS (Root Mean Square) value of the voltage
9	STDDev	σ (S-dev)	Standard deviation of the waveform
10	POVershoot	Pos. overshoot	Positive overshoot of a square wave
11	NOVershoot	Neg. overshoot	Negative overshoot of a square wave
12	AREA	Area	Area beneath the waveform (integral)
13	RTIME	Rise time	Rise time of the left-most rising edge of the waveform.
14	FTIME	Fall time	Falling time of the left-most falling edge of the waveform.
15	PPULse	Pos. pulse	Width of a positive pulse – a rising edge followed by a falling edge. The measurement requires at least one complete period of a triggered signal.
16	NPULse	Neg. pulse	Width of a negative pulse – a falling edge followed by a rising edge. The measurement requires at least one complete period of a triggered signal.
17	PERiod	Period	Length of the left-most signal period of the waveform
18	FREQuency	Frequency	Frequency of the signal. The result is based on the period measurement.
19	PDCYcle	Pos. duty cycle	Positive duty cycle. The measurement requires at least one complete period of a triggered signal.
20	NDCYcle	Neg. duty cycle	Negative duty cycle. The measurement requires at least one complete period of a triggered signal.
21	CYCarea	Cycle area	Area (integral) beneath one cycle
22	CYCMean	Cycle mean	Mean value of one cycle
23	CYCRms	Cycle RMS	The RMS (Root Mean Square) value of one cycle
24	CYCStddev	Cycle σ (S-dev)	Standard deviation of one cycle
25	PULCnt	Pulse count	Number of positive or negative pulses of the waveform, or both
26	DElay	Delay	Time difference between the any edges of two measurement sources at any reference level. The measurement result is negative if the edge of the second source comes before the edge of the first source.

Meas. suffix	<MeasType> parameter value	Meas. type	Description/Result
27	PHASe	Phase	Phase difference between two waveforms
28	BWIDth	Burst width	Duration of one burst, measured from the first edge to the last
29	PSWitching	Pos. switching	Settling time at rising edges
30	NSWitching	Neg. switching	Settling time at falling edges
31	PULSetrain	Pulse train	Duration of N positive pulses, measured from the rising edge of the first pulse to the falling edge of the N-th pulse. N has to be configured.
32	EDGecount	Edge count	Number of positive or negative edges of the waveform, or both
33	SETup	Setup time	Parameters to query the setup and hold times.
34	HOLD	Hold time	Use these parameters only in queries with MEASurement<m>:ARES? on page 842 and MEASurement<n>:RESult... commands.
35	SHT	Setup/Hold time	Setting parameter to enable Setup/Hold time measurements. Use this parameter only as setting with MEASurement<m>:MAIN on page 792 and MEASurement<m>:ADDITIONal on page 794
36	SHR	Setup/Hold ratio	Setup/Hold ratio measurement. Setup/Hold ratio is the ratio of the setup time to the sum of hold and setup time: $T_{Setup} / (T_{Setup} + T_{Hold})$ Used as setting to activate the Setup/Hold ratio measurement with MEASurement<m>:MAIN on page 792 and MEASurement<m>:ADDITIONal on page 794 Used also in queries with MEASurement<m>:ARES? on page 842 and MEASurement<n>:RESult... commands.
46	DTOTrigger	Delay to trigger	Time between the trigger event and a following signal slope. High accuracy even if the trigger event is outside the acquisition data.
47	PROBemeter	Trig. ProbeMeter	DC voltage measured by the connected active R&S probe
37 to 45	Used for jitter measurements (limit checks) see chapter 21.2.20.1, "Jitter Measurements (Option R&S RTO-K12)" , on page 1075.		



Change of PROBemeter suffix

The suffix of the PROBemeter parameter has been changed. In FW ≤ 1.50, the suffix is 46. In FW ≥ 1.52, the suffix is 47.

MEASurement<m>:ENVSelect	813
MEASurement<m>:DETThreshold	813
MEASurement<m>:AMPTime:ALEVel	814
MEASurement<m>:AMPTime:PSLope	814

MEASurement<m>:AMPTime:DElay<n>:DIRection.....	814
MEASurement<m>:AMPTime:DElay<n>:ECOunt.....	815
MEASurement<m>:AMPTime:DElay<n>:LSElect.....	815
MEASurement<m>:AMPTime:DElay<n>:SLOPe.....	815
MEASurement<m>:AMPTime:PTCount.....	815
MEASurement<m>:AMPTime:ESLOpe.....	816
MEASurement<m>:AMPTime:CSLOpe.....	816
MEASurement<m>:AMPTime:CLCK<n>:LSElect.....	816
MEASurement<m>:AMPTime:DATA<n>:LSElect.....	817
MEASurement<m>:AMPTime:DTOTrigger<n>:SLOPe.....	817
MEASurement<m>:AMPTime:DTOTrigger<n>:LSElect.....	817
MEASurement<m>:AMPTime:LCHeck<n>:VALid.....	818
MEASurement<m>:AMPTime:LCHeck<n>:LOWer:LIMit.....	818
MEASurement<m>:AMPTime:LCHeck<n>:UPPer:LIMit.....	818
MEASurement<m>:AMPTime:LCHeck<n>:LOWer:MARGin.....	818
MEASurement<m>:AMPTime:LCHeck<n>:UPPer:MARGin.....	818

MEASurement<m>:ENVSelect <EnvelopeCurve>

The command is only relevant for measurements on envelope waveforms. It selects the envelope to be used for measurement.

Suffix:

<m> 1..9
See "[Measurement selection: MEASurement<m>](#)" on page 789.

Parameters:

<EnvelopeCurve> MIN | MAX | BOTH
 MIN: measures on the lower envelope
 MAX: measures on the upper envelope
 BOTH: the envelope is ignored and the waveform measured as usual
 *RST: BOTH

Firmware/Software: V 1.25

MEASurement<m>:DETThreshold <SignDetectThres>

Defines the value above which measurement results are displayed. Values beneath the threshold are considered to be noise and they are ignored.

Suffix:

<m> 1..9
irrelevant

Parameters:

<SignDetectThres> Range: 0 to 50
 Increment: 1
 *RST: 5
 Default unit: %

MEASurement<m>:AMPTime:ALEVel <AreaLevel>

Defines the reference level used to integrate the waveform.

Suffix:

<m> 1..9
See "[Measurement selection: MEASurement<m>](#)" on page 789.

Parameters:

<AreaLevel> Range: -100E+24 to 100E+24
Increment: 0
*RST: 0
Default unit: V

MEASurement<m>:AMPTime:PSLope <PulsesSlope>

Sets the first slope of the pulses to be counted. The setting is only relevant for pulse count measurement (MEASurement<m>:MAIN PULCnt or MEASurement<m>:ADDITIONAL PULCnt, ON).

Suffix:

<m> 1..9
See "[Measurement selection: MEASurement<m>](#)" on page 789.

Parameters:

<PulsesSlope> POSitive | NEGative | EITHER
Count either positive or negative pulses, or both.
*RST: POSitive

MEASurement<m>:AMPTime:DELay<n>:DIRection <EdgeCountDirection>

Selects the direction for counting slopes for each source: from the beginning of the waveform, or from the end.

Suffix:

<m> 1..9
See "[Measurement selection: MEASurement<m>](#)" on page 789.

<n> 1..2
Selects the source number.

Parameters:

<EdgeCountDirection>FRFI | FRLA
FRFI - FRom FIrst, counting starts with the first edge of the waveform.
FRLA - FRom LAsT, counting starts with the last edge of the waveform.
*RST: FRFI

MEASurement<m>:AMPTime:DELay<n>:ECOunt <EdgeIndex>

Sets the number of the edge that is relevant for delay measurement for each source.

Suffix:

<m>	1..9	See " Measurement selection: MEASurement<m> " on page 789.
<n>	1..2	Selects the source number.

Parameters:

<EdgeIndex>	Edge number
	Range: 1 to 100000
	Increment: 1
	*RST: 1

MEASurement<m>:AMPTime:DELay<n>:LSElect <DelayLevSelection>

Selects the reference level on which the time is measured for each source.

Suffix:

<m>	1..9	See " Measurement selection: MEASurement<m> " on page 789.
<n>	1..2	Selects the source number.

Parameters:

<DelayLevSelection>	UPPer MIDDle LOWer
	*RST: MIDDle

MEASurement<m>:AMPTime:DELay<n>:SLOPe <Slope>

Sets the edge of each source, between which the delay is measured.

Suffix:

<m>	1..9	See " Measurement selection: MEASurement<m> " on page 789.
<n>	1..2	Selects the source number.

Parameters:

<Slope>	POSitive NEGative EITHer
	*RST: POSitive

MEASurement<m>:AMPTime:PTCount <PulseCount>

Sets the number of positive pulses for the pulse train measurement. It measures the duration of N positive pulses from the rising edge of the first pulse to the falling edge of the N-th pulse.

Suffix:

<m> 1..9
See "[Measurement selection: MEASurement<m>](#)" on page 789.

Parameters:

<PulseCount> Range: 1 to 2147483647
Increment: 1
*RST: 1

MEASurement<m>:AMPTime:ESLope <EdgesSlope>

Sets the edge direction to be counted: rising edges, falling edges, or both. The setting is only relevant for edge count measurement (MEASurement<m>:MAIN EDGecount or MEASurement<m>:ADDITIONal EDGecount, ON).

Suffix:

<m> 1..9
See "[Measurement selection: MEASurement<m>](#)" on page 789.

Parameters:

<EdgesSlope> POSitive | NEGative | EITHER
*RST: POSitive

MEASurement<m>:AMPTime:CSLope <SetupHoldClockSlope>

Sets the edge of the clock from which the setup and hold times are measured.

Suffix:

<m> 1..9
See "[Measurement selection: MEASurement<m>](#)" on page 789.

Parameters:

<SetupHoldClockSlope> POSitive | NEGative | EITHER
EITHER
The clock edges next to the data edge are considered regardless of the clock slope.
*RST: POSitive

MEASurement<m>:AMPTime:CLCK<n>:LSElect <ClockLevel>

Selects the reference level of the clock on which the time is measured. Reference level and clock slope define the time point for setup and hold measurements.

Suffix:

<m> 1..9
See "[Measurement selection: MEASurement<m>](#)" on page 789.

<n> 1..2
The suffix is irrelevant, omit it.

Parameters:

<ClockLevel> UPPer | MIDDle | LOWer
 *RST: MIDDle

MEASurement<m>:AMPTime:DATA<n>:LSElect <DataLevel>

Selects the reference level of the data on which the setup and hold time are measured.

Suffix:

<m> 1..9
 See "[Measurement selection: MEASurement<m>](#)" on page 789.

<n> 1..2
 The suffix is irrelevant, omit it.

Parameters:

<DataLevel> UPPer | MIDDle | LOWer
 *RST: MIDDle

MEASurement<m>:AMPTime:DTOTrigger<n>:SLOPe <Slope>

Sets the edge direction to be used for delay measurement.

Suffix:

<m> 1..9
 See "[Measurement selection: MEASurement<m>](#)" on page 789.

<n> 1..2
 The suffix is irrelevant.

Parameters:

<Slope> POSitive | NEGative | EITHer
 *RST: POSitive

MEASurement<m>:AMPTime:DTOTrigger<n>:LSElect <RefLevel>

Selects the reference level of the measurement source on which the delay is measured.

Suffix:

<m> 1..9
 See "[Measurement selection: MEASurement<m>](#)" on page 789.

<n> 1..2
 The suffix is irrelevant.

Parameters:

<RefLevel> UPPer | MIDDle | LOWer
 *RST: MIDDle

MEASurement<m>:AMPTime:LCHeck<n>:VALid <ValidRange>

Enables or disables limit checking for amplitude vs. time measurements in the specified measurement channel.

Suffix:

<m>	1..9 See " Measurement selection: MEASurement<m> " on page 789.
<n>	1..47 Number of the amplitude/time measurement type, see table 21-15 .

Parameters:

<ValidRange>	ILIMit ULIMit LLIMit OLIMit
	ILIMit Inside (within) limit; between the upper and lower limit values
	ULIMit Upper limit; above the upper limit value
	LLIMit Lower limit; below the lower limit value
	OLIMit Outside limit; above the upper limit or below the lower limit values
*RST:	ILIMit

MEASurement<m>:AMPTime:LCHeck<n>:LOWer:LIMit <Limit>**MEASurement<m>:AMPTime:LCHeck<n>:UPPer:LIMit <UpperLimit>**

Define the lower and upper limit for limit checking, respectively. The valid range is defined using the [MEASurement<m>:AMPTime:LCHeck<n>:VALid](#) command.

Suffix:

<m>	1..9 See " Measurement selection: MEASurement<m> " on page 789.
<n>	1..47 Number of the amplitude/time measurement type, see table 21-15 .

Parameters:

<UpperLimit>	Range: -100 to 100
	Increment: 10E-6
*RST:	0

MEASurement<m>:AMPTime:LCHeck<n>:LOWer:MARGin <Margin>**MEASurement<m>:AMPTime:LCHeck<n>:UPPer:MARGin <Margin>**

Define the lower and upper margins for the limit check, respectively. Margins are not as strict as limits and must be within the valid value range. The valid range is defined using the [MEASurement<m>:AMPTime:LCHeck<n>:VALid](#) command.

Suffix:

<m> 1..9
See "[Measurement selection: MEASurement<m>](#)" on page 789.

<n> 1..47
Number of the amplitude/time measurement type, see [table 21-15](#).

Parameters:

<Margin> Range: -100 to 100
Increment: 10E-6
*RST: 0

21.2.11.4 Eye Diagram Measurements

The following table lists the measurement suffixes and the <MeasType> parameter value with a short description.

For a detailed description, see [chapter 7.2.1.3, "Eye Diagram Measurements"](#), on page 238.

Table 21-16: Eye diagram measurement types

Meas. suffix	<MeasType> parameter value	Meas. type	Description/Result
1			not used
2	ERPercent	Extinction ratio (%)	Eye base / Eye top *100 Prerequisite: Eye base > 0 and Eye top > 0
3	ERDB	Extinction ratio (dB)	10*log (Eye top / Eye base)
4	EHEight	Eye height	Vertical eye opening
5	EWIDth	Eye width	Horizontal eye opening
6	ETOP	Eye top	Mean of the upper vertical histogram
7	EBASe	Eye base	Mean of the lower vertical histogram
8...9			not used
10	QFActor	Q factor	(Eye top – Eye base) / (σ_{top} + σ_{base})
11...13			not used
14	RMSNoise	Noise (RMS)	Quadratic mean of the noise of eye top and eye base
15	SNRatio	S/N ratio	Signal-to-noise ratio 10 * log (Eye amplitude / Noise RMS)
16	DCDistortion	Duty cycle distortion	20 * log (Eye amplitude / Noise RMS)
17	ERTime	Eye rise time	Duration for signal to rise from 10% to 90% of the high signal level
18	EFTime	Eye fall time	Duration for signal to fall from 90% to 10% of the high signal level

Meas. suffix	<MeasType> parameter value	Meas. type	Description/Result
19	EBRate	Eye bit rate	Frequency between two crossings
20	EAMplitude	Eye amplitude	Eye top - Eye base
21...27			not used
28	PPJitter	Jitter (peak to peak)	Average of the jitter for both crossing points ($\sigma_{\text{crossing1}} + \sigma_{\text{crossing2}}$) / 2
29	STDJitter	Jitter (6σ)	Jitter *6
30	RMSJitter	Jitter (RMS)	Quadratic mean of the jitter at both crossing points

MEASurement<m>:EYEJitter:LCHeck<n>:VALid.....	820
MEASurement<m>:EYEJitter:LCHeck<n>:LOWer:LIMit.....	820
MEASurement<m>:EYEJitter:LCHeck<n>:UPPer:LIMit.....	820
MEASurement<m>:EYEJitter:LCHeck<n>:LOWer:MARGin.....	821
MEASurement<m>:EYEJitter:LCHeck<n>:UPPer:MARGin.....	821

MEASurement<m>:EYEJitter:LCHeck<n>:VALid <ValidRange>

Enables or disables limit checking for eye/jitter measurements in the specified measurement channel.

Suffix:

<m>	1..9 See " Measurement selection: MEASurement<m> " on page 789.
<n>	1..30 Number of eye/jitter measurement type, see table 21-16 .

Parameters:

<ValidRange>	ILIMit ULIMit LLIMit OLIMit
	ILIMit Inside (within) limit; between the upper and lower limit values
	ULIMit Upper limit; above the upper limit value
	LLIMit Lower limit; below the lower limit value
	OLIMit Outside limit; above the upper limit or below the lower limit values
*RST:	ILIMit

MEASurement<m>:EYEJitter:LCHeck<n>:LOWer:LIMit <LowerLimit>

MEASurement<m>:EYEJitter:LCHeck<n>:UPPer:LIMit <UpperLimit>

Define the lower and upper limit for the limit check, respectively. The valid range is defined using the [MEASurement<m>:EYEJitter:LCHeck<n>:VALid](#) command.

Suffix:

<m> 1..9
See "[Measurement selection: MEASurement<m>](#)" on page 789.

<n> 1..30
Number of eye/jitter measurement type, see [table 21-16](#).

Parameters:

<LowerLimit> Range: -100 to 100
<UpperLimit> Increment: 10E-6
*RST: 0

MEASurement<m>:EYejitter:LCHeck<n>:LOWer:MARGin <LowerMargin>

MEASurement<m>:EYejitter:LCHeck<n>:UPPer:MARGin <UpperMargin>

Defines the upper margin for the limit check. Margins are not as strict as limits and must be within the valid value range. The valid range is defined using the [MEASurement<m>:EYejitter:LCHeck<n>:VALid](#) command.

Suffix:

<m> 1..9
See "[Measurement selection: MEASurement<m>](#)" on page 789.

<n> 1..30
Number of eye/jitter measurement type, see [table 21-16](#).

Parameters:

<Lower Margin> Range: -100 to 100
<UpperMargin> Increment: 10E-6
*RST: 0

21.2.11.5 Spectrum

The following table lists the measurement suffixes and the <MeasType> parameter value with a short description.

For a detailed description, see [chapter 7.2.1.5, "Spectrum Measurements"](#), on page 242.

Table 21-17: Spectrum measurement types

Meas. suffix	<MeasType> parameter value	Meas. type	Description/Result
1	CPOWer	Channel power	Power integrated over the sample values defined by a center frequency and a bandwidth; based on a defined impedance; the result is given in mW
2	OBWidth	Occupied band-width	From the defined center frequency, symmetric sample value pairs to the left and right are integrated until a user-defined percentage of the total power is reached

Meas. suffix	<MeasType> parameter value	Meas. type	Description/Result
3	SBWidth	Bandwidth	n dB down Bandwidth; the samples to the left and right of the peak value are analyzed until the n dB threshold is exceeded; the frequencies at which the threshold is exceeded define the limits of the requested bandwidth
4	THD	Total harmonic distortion	Power sum of the harmonic waves divided by the power of the fundamental wave.
5..8			not used
9	HAR	Harmonic search	

MEASurement<m>:SPECTrum:CPOWER:BANDwidth.....	822
MEASurement<m>:SPECTrum:OBANDwidth.....	822
MEASurement<m>:SPECTrum:CPOWER:CFRequency.....	823
MEASurement<m>:SPECTrum:NDBDown.....	823
MEASurement<m>:SPECTrum:NREJect.....	823
MEASurement<m>:SPECTrum:LCHeck<n>:VALid.....	823
MEASurement<m>:SPECTrum:LCHeck<n>:LOWer:LIMit.....	824
MEASurement<m>:SPECTrum:LCHeck<n>:UPPer:LIMit.....	824
MEASurement<m>:SPECTrum:LCHeck<n>:LOWer:MARGin.....	824
MEASurement<m>:SPECTrum:LCHeck<n>:UPPer:MARGin.....	824

MEASurement<m>:SPECTrum:CPOWER:BANDwidth <ChPowBandwidth>

Defines the bandwidth over which the channel power is calculated.

Suffix:

<m> 1..9
See "[Measurement selection: MEASurement<m>](#)" on page 789.

Parameters:

<ChPowBandwidth> Range: 0 to 4E+9
Increment: 1
*RST: 0
Default unit: Hz

MEASurement<m>:SPECTrum:OBANDwidth <OccupiedBW>

Defines the percentage of the total power used to determine the occupied bandwidth.

Suffix:

<m> 1..9
See "[Measurement selection: MEASurement<m>](#)" on page 789.

Parameters:

<OccupiedBW> Range: 0.1 to 99.9
Increment: 1
*RST: 20
Default unit: %

MEASurement<m>:SPECtrum:CPOWER:CFRequency <CenterFreq>

Defines the center frequency from which the channel power is calculated over the specified bandwidth.

Suffix:

<m> 1..9

See "[Measurement selection: MEASurement<m>](#)" on page 789.

Parameters:

<CenterFreq> Range: 0 to 6E+9
 Increment: 1
 *RST: 0
 Default unit: Hz

MEASurement<m>:SPECtrum:NDBDown <NDbDown>

Defines the threshold until which the samples to the left and right of the peak value are analyzed in order to determine the "N dB down bandwidth".

Suffix:

<m> 1..9

See "[Measurement selection: MEASurement<m>](#)" on page 789.

Parameters:

<NDbDown> Range: 0 to 100
 Increment: 1
 *RST: 20
 Default unit: dB

MEASurement<m>:SPECtrum:NREJect <NoiseReject>

Defines the threshold beneath which values are rejected as noise.

Suffix:

<m> 1..9

See "[Measurement selection: MEASurement<m>](#)" on page 789.

Parameters:

<NoiseReject> Range: 0 to 100
 Increment: 1
 *RST: 0
 Default unit: dB

MEASurement<m>:SPECtrum:LCHeck<n>:VALid <ValidRange>

Enables or disables limit checking for spectrum measurements in the specified measurement channel.

Suffix:

<m> 1..9

See "[Measurement selection: MEASurement<m>](#)" on page 789.

<n> 1..9
Number of spectrum measurement type, see [table 21-17](#).

Parameters:

<ValidRange>

ILIMit | ULIMit | LLIMit | OLIMit

ILIMit

Inside (within) limit; between the upper and lower limit values

ULIMit

Upper limit; above the upper limit value

LLIMit

Lower limit; below the lower limit value

OLIMit

Outside limit; above the upper limit or below the lower limit values

*RST: ILIMit

MEASurement<m>:SPECtrum:LCHeck<n>:LOWer:LIMit <LowerLimit>**MEASurement<m>:SPECtrum:LCHeck<n>:UPPer:LIMit** <UpperLimit>

Define the lower and upper limits for the limit check, respectively. The valid range is defined using the [MEASurement<m>:SPECtrum:LCHeck<n>:VALid](#) command.

Suffix:

<m> 1..9
See "[Measurement selection: MEASurement<m>](#)" on page 789.

<n> 1..9
Number of spectrum measurement type, see [table 21-17](#).

Parameters:

<UpperLimit>

Range: -100 to 100

Increment: 10E-6

*RST: 0

MEASurement<m>:SPECtrum:LCHeck<n>:LOWer:MARGIN <LowerMargin>**MEASurement<m>:SPECtrum:LCHeck<n>:UPPer:MARGIN** <UpperMargin>

Define the lower and upper margins for the limit check, respectively. Margins are not as strict as limits and must be within the valid value range. The valid range is defined using the [MEASurement<m>:SPECtrum:LCHeck<n>:VALid](#) command.

Suffix:

<m> 1..9
See "[Measurement selection: MEASurement<m>](#)" on page 789.

<n> 1..9
Number of spectrum measurement type, see [table 21-17](#).

Parameters:

<UpperMargin> Range: -100 to 100
 Increment: 10E-6
 *RST: 0

21.2.11.6 Histograms

See also: [chapter 21.2.15.3, "Waveform Histogram Export"](#), on page 926

- [Histogram Display](#)..... 825
- [Histogram Measurement](#)..... 830

Histogram Display

LAYout:HISTogram:ADD	825
LAYout:HISTogram:SOURce	826
LAYout:HISTogram:MODE	826
LAYout:HISTogram:HORIZ:MODE	827
LAYout:HISTogram:HORIZ:ABSolute:START	827
LAYout:HISTogram:HORIZ:ABSolute:STOP	827
LAYout:HISTogram:HORIZ:RELative:START	827
LAYout:HISTogram:HORIZ:RELative:STOP	828
LAYout:HISTogram:VERTical:MODE	828
LAYout:HISTogram:VERTical:ABSolute:START	828
LAYout:HISTogram:VERTical:ABSolute:STOP	828
LAYout:HISTogram:VERTical:RELative:START	829
LAYout:HISTogram:VERTical:RELative:STOP	829
LAYout:HISTogram:RESet	829
LAYout:HISTogram:REMove	829

LAYout:HISTogram:ADD <HistogramName>, <Source>, <XStart>, <XStop>, <YStart>, <YStop>, <Relative>, <eOrientation>

Defines and displays a new histogram for the specified source.

Note: To define the mode of the histogram (vertical or horizontal), use the [LAYout:HISTogram:MODE](#) command.

Setting parameters:

<HistogramName> String defining the histogram name which is used to refer to the histogram by other functions.

<Source> NONE | C1W1 | C1W2 | C1W3 | C2W1 | C2W2 | C2W3 | C3W1 | C3W2 | C3W3 | C4W1 | C4W2 | C4W3 | M1 | M2 | M3 | M4 | R1 | R2 | R3 | R4
 Data source of the histogram, see [chapter 21.2.3.2, "Waveform Parameter"](#), on page 666
 *RST: NONE

<XStart> Defines the start value of the x-value range.

<XStop> Defines the stop value of the x-value range.

<YStart>	Defines the start value of the y-value range.
<YStop>	Defines the stop value of the y-value range.
<Relative>	ON OFF Defines whether relative or absolute values are used for the value range definition.
<Orientation>	VERTical HORizontal
Example:	See " Creating and Reading Histograms " on page 1129
Usage:	Setting only

LAYout:HISTogram:SOURce <HistogramName>,<HistogramSource>

LAYout:HISTogram:SOURce? <HistogramName>

Defines the source of the histogram. Any analog input signal, math or reference waveform and measurement can be selected.

Parameters:

<HistogramSource> NONE | C1W1 | C1W2 | C1W3 | C2W1 | C2W2 | C2W3 | C3W1 | C3W2 | C3W3 | C4W1 | C4W2 | C4W3 | M1 | M2 | M3 | M4 | R1 | R2 | R3 | R4 | MRESult1 | MRESult2 | MRESult3 | MRESult4 | MRESult5 | MRESult6 | MRESult7 | MRESult8

Waveform source of the histogram, see [chapter 21.2.3.2, "Waveform Parameter"](#), on page 666. If a measurement is the histogram source, the density distribution of the results of the main measurement is displayed.

*RST: NONE

Parameters for setting and query:

<HistogramName> String parameter

LAYout:HISTogram:MODE <HistogramName>,<Mode>

LAYout:HISTogram:MODE? <HistogramName>

Defines or queries the type of histogram.

Parameters:

<Mode> VERTical | HORizontal

VERTical

Amplitude histogram (horizontal bars across amplitude)

HORizontal

Time or frequency histogram (vertical bars over time/frequencies)

*RST: VERTical

Parameters for setting and query:

<HistogramName> The name of the histogram as defined using [LAYout:HISTogram:ADD](#) on page 825.

LAYout:HISTogram:HORZ:MODE <HistogramName>,<Mode>
LAYout:HISTogram:HORZ:MODE? <HistogramName>

Defines or queries whether the value range limits are entered as absolute or relative values.

Parameters:

<Mode> ABS | REL
 *RST: ABS

Parameters for setting and query:

<HistogramName>

LAYout:HISTogram:HORZ:ABSolute:START <HistogramName>,<Start>
LAYout:HISTogram:HORZ:ABSolute:START? <HistogramName>

Defines the horizontal start value of the histogram.

Parameters:

<Start> Range: -100E+24 to 100E+24
 Increment: 0.01
 *RST: 0.01

Parameters for setting and query:

<HistogramName>

LAYout:HISTogram:HORZ:ABSolute:STOP <HistogramName>,<Stop>
LAYout:HISTogram:HORZ:ABSolute:STOP? <HistogramName>

Defines the horizontal stop value of the histogram.

Parameters:

<Stop> Range: -100E+24 to 100E+24
 Increment: 0.01
 *RST: 0.01

Parameters for setting and query:

<HistogramName>

LAYout:HISTogram:HORZ:RELative:START <HistogramName>,<RelativeStart>
LAYout:HISTogram:HORZ:RELative:START? <HistogramName>

Defines the horizontal start value of the histogram.

Parameters:

<RelativeStart> Range: -100E+24 to 100E+24
 Increment: 0.1
 *RST: 0
 Default unit: %

Parameters for setting and query:

<HistogramName>

Usage: SCPI confirmed

LAYout:HISTogram:HORZ:RELative:STOP <HistogramName>,<RelativeStop>
LAYout:HISTogram:HORZ:RELative:STOP? <HistogramName>

Defines the horizontal stop value of the histogram.

Parameters:

<RelativeStop> Range: -100E+24 to 100E+24
 Increment: 0.1
 *RST: 100
 Default unit: %

Parameters for setting and query:

<HistogramName>

Usage: SCPI confirmed

LAYout:HISTogram:VERTical:MODE <HistogramName>,<Mode>
LAYout:HISTogram:VERTical:MODE? <HistogramName>

Defines or queries whether the value range limits are entered as absolute or relative values.

Parameters:

<Mode> ABS | REL
 *RST: ABS

Parameters for setting and query:

<HistogramName>

LAYout:HISTogram:VERTical:ABSolute:START <HistogramName>,<Start>
LAYout:HISTogram:VERTical:ABSolute:START? <HistogramName>

Defines the vertical start value of the histogram.

Parameters:

<Start> Range: -100E+24 to 100E+24
 Increment: 0.01
 *RST: 0.01

Parameters for setting and query:

<HistogramName>

LAYout:HISTogram:VERTical:ABSolute:STOP <HistogramName>,<Stop>
LAYout:HISTogram:VERTical:ABSolute:STOP? <HistogramName>

Defines the vertical stop value of the histogram.

Parameters:

<Stop> Range: -100E+24 to 100E+24
 Increment: 0.01
 *RST: 0.01

Parameters for setting and query:

<HistogramName>

LAYout:HISTogram:VERTical:RELative:STARt <HistogramName>,<RelativeStart>

LAYout:HISTogram:VERTical:RELative:STARt? <HistogramName>

Defines the vertical start value of the histogram.

Parameters:

<RelativeStart> Range: -100E+24 to 100E+24
 Increment: 0.1
 *RST: 0
 Default unit: %

Parameters for setting and query:

<HistogramName>

Usage: SCPI confirmed

LAYout:HISTogram:VERTical:RELative:STOP <HistogramName>,<RelativeStop>

LAYout:HISTogram:VERTical:RELative:STOP? <HistogramName>

Defines the vertical stop value of the histogram.

Parameters:

<RelativeStop> Range: -100E+24 to 100E+24
 Increment: 0.1
 *RST: 100
 Default unit: %

Parameters for setting and query:

<HistogramName>

Usage: SCPI confirmed

LAYout:HISTogram:RESet <HistogramName>

Resets the values to begin a new histogram.

Setting parameters:

<HistogramName>

Usage: Setting only

LAYout:HISTogram:REMove <Name>

Removes the specified histogram.

Setting parameters:

<Name>

Usage: Setting only**Histogram Measurement**

The main and additional histogram measurements are done with `MEASurement<m>:MAIN` and `MEASurement<m>:ADDITIONal`.

See also: "[Creating and Reading Histograms](#)" on page 1129.

The following table lists the measurement suffixes and the <MeasType> parameter value with a short description.

For a detailed description of histograms, see [chapter 7.2.1.4, "Histograms"](#), on page 240.

Table 21-18: Histogram measurement types

Meas. suffix	<MeasType> parameter value	Meas. type	Description/Result
1	WCOunt	Waveform count	Number of acquisitions (waveforms) the histogram is based on
2	WSAMples	Waveform samples	Number of samples from the most recent acquisition included in the current histogram
3	HSAMples	Histogram samples	Number of samples from all acquisitions included in the current histogram
4	HPEak	Histogram peak	Maximum sample value in the histogram
5	PEAK	Peak value	Signal value at the histogram peak
6	UPEakvalue	Upper peak value	Signal value at the maximum sample value in the upper half of the histogram
7	LPEakvalue	Lower peak value	Signal value at the maximum sample value in the lower half of the histogram
8	HMAXimum	Maximum	Highest signal value with a probability > 0
9	HMINimum	Minimum	Lowest signal value with a probability > 0
10	MEDian	Median	Signal value for which half the samples lie above, the other half below in the histogram
11	MAXMin	Max - Min	Range of signal values with a probability > 0
12	HMEan	Mean	Weighted arithmetic average of the histogram
13	HSTDdev	σ (S-dev)	Standard deviation of the sample numbers
14	M1STddev	Mean $\pm\sigma$	Range between (mean value + standard deviation) and (mean value - standard deviation)
15	M2STddev	Mean $\pm 2*\sigma$	Range between (mean value + 3 * standard deviation) and (mean value - 2 * standard deviation)
16	M3STddev	Mean $\pm 3*\sigma$	Range between (mean value + 3 * standard deviation) and (mean value - 2 * standard deviation)

Meas. suffix	<MeasType> parameter value	Meas. type	Description/Result
17	MKPositive	Marker + Probability %	Marker value (according to the selected probability domain marker type) plus the defined limit. Note that the value is restricted to the histogram range.
18	MKNegative	Marker - Probability %	Marker value (according to the selected probability domain marker type) minus the defined limit. Note that the value is restricted to the histogram range.

MEASurement<m>:HISTogram:SElect	831
MEASurement<m>:HISTogram:PROBability:TYPE	831
MEASurement<m>:HISTogram:PROBability:LIMit	832
MEASurement<m>:HISTogram:LCHeck<n>:VALid	832
MEASurement<m>:HISTogram:LCHeck<n>:LOWer:LIMit	833
MEASurement<m>:HISTogram:LCHeck<n>:UPPer:LIMit	833
MEASurement<m>:HISTogram:LCHeck<n>:LOWer:MARGin	833
MEASurement<m>:HISTogram:LCHeck<n>:UPPer:MARGin	833

MEASurement<m>:HISTogram:SElect <HistogramName>

Selects the histogram on which the measurement is based.

Suffix:

<m> 1..9
See "[Measurement selection: MEASurement<m>](#)" on page 789.

Parameters:

<HistogramName> String with the name of the histogram

Example: See "[Creating and Reading Histograms](#)" on page 1129

MEASurement<m>:HISTogram:PROBability:TYPE <Marker>

Defines the marker reference in the probability domain.

Suffix:

<m> 1..9
See "[Measurement selection: MEASurement<m>](#)" on page 789.

Parameters:

<Marker>	PEAK UPPK LWPK MAXimum MINimum MEDian MEAN
	PEAK The y-value with the maximum sample value in the histogram
	UPPK The y-value at the maximum sample value in the upper half of the histogram
	LWPK The y-value at the maximum sample value in the lower half of the histogram
	MAXimum The highest y-value with a probability > 0
	MINimum The lowest y-value with a probability > 0
	MEDian The y-value for which half the samples lie above, the other half below in the histogram
	MEAN The weighted arithmetic average of the histogram
	*RST: PEAK

MEASurement<m>:HISTogram:PROBability:LIMit <Limit>

Defines a range around the probability marker.

Suffix:

<m>	1..9 See " Measurement selection: MEASurement<m> " on page 789.
-----	--

Parameters:

<Limit>	Range: 0 to 100
	Increment: 10
	*RST: 10
	Default unit: %

MEASurement<m>:HISTogram:LCHeck<n>:VALid <ValidRange>

Enables or disables limit checking for histogram measurements in the specified measurement channel.

Suffix:

<m>	1..9 See " Measurement selection: MEASurement<m> " on page 789.
<n>	1..18 Number of histogram measurement type, see table 21-18 .

Parameters:

<ValidRange> ILIMit | ULIMit | LLIMit | OLIMit

ILIMit

Inside (within) limit; between the upper and lower limit values

ULIMit

Upper limit; above the upper limit value

LLIMit

Lower limit; below the lower limit value

OLIMit

Outside limit; above the upper limit or below the lower limit values

*RST: ILIMit

MEASurement<m>:HISTogram:LCHeck<n>:LOWer:LIMit <LowerLimit>

MEASurement<m>:HISTogram:LCHeck<n>:UPPer:LIMit <UpperLimit>

Define the lower and upper limits for the limit check, respectively. The valid range is defined using the [MEASurement<m>:HISTogram:LCHeck<n>:VALid](#) command.

Suffix:

<m> 1..9

See "[Measurement selection: MEASurement<m>](#)" on page 789.

<n> 1..18

Number of histogram measurement type, see [table 21-18](#).

Parameters:

<Lower Limit> Range: -100 to 100

<UpperLimit> Increment: 10E-6

*RST: 0

MEASurement<m>:HISTogram:LCHeck<n>:LOWer:MARGin <LowerMargin>

MEASurement<m>:HISTogram:LCHeck<n>:UPPer:MARGin <UpperMargin>

Define the lower and upper margins for the limit check, respectively. Margins are not as strict as limits and must be within the valid value range. The valid range is defined using the [MEASurement<m>:HISTogram:LCHeck<n>:VALid](#) command.

Suffix:

<m> 1..9

See "[Measurement selection: MEASurement<m>](#)" on page 789.

<n> 1..18

Number of histogram measurement type, see [table 21-18](#).

Parameters:

<Lower Margin> Range: -100 to 100

<UpperMargin> Increment: 10E-6

*RST: 0

21.2.11.7 Display

MEASurement<m>:DISPlay:LEVels.....	834
MEASurement<m>:DISPlay:RESults.....	834
MEASurement<m>:DISPlay:STYLe.....	834
MEASurement<m>:DISPlay:HISTogram.....	835

MEASurement<m>:DISPlay:LEVels <DisplayLevels>

If enabled, the reference levels used for the measurement are displayed in the diagram.

Suffix:

<m> 1..9
See "[Measurement selection: MEASurement<m>](#)" on page 789.

Parameters:

<DisplayLevels> ON | OFF
*RST: OFF

MEASurement<m>:DISPlay:RESults <DisplayResult>

If enabled, the intermediate result lines required to obtain the measurement result (e.g. signal thresholds) are displayed in the measurement diagram.

Suffix:

<m> 1..9
See "[Measurement selection: MEASurement<m>](#)" on page 789.

Parameters:

<DisplayResult> ON | OFF
*RST: OFF

MEASurement<m>:DISPlay:STYLe <DisplayStyle>

Selects the style in which the measurement waveform is displayed.

Suffix:

<m> 1..9
See "[Measurement selection: MEASurement<m>](#)" on page 789.

Parameters:

<DisplayStyle> LINE | MARKer
LINE
The individual data points are connected by a line.
MARKer
Only the individual data points are displayed as markers.
*RST: LINE

MEASurement<m>:DISPlay:HISTogram <DispHistg>

Displays a histogram for the source of the selected measurement.

Suffix:

<m> 1..9
See "Measurement selection: MEASurement<m>" on page 789.

Parameters:

<DispHistg> ON | OFF
*RST: OFF

21.2.11.8 Limit check

MEASurement<m>:LCheck..... 835

MEASurement<m>:LCheck <LimitCheckState>

Defines the type of the limit check that can run together with the measurement.

Suffix:

<m> 1..9
See "Measurement selection: MEASurement<m>" on page 789.

Parameters:

<LimitCheckState> OFF | LIMit | LMARgin
OFF
No limit check.
LIMit
Only limits are checked.
LMARgin
Limits and margins are checked.
*RST: OFF

21.2.11.9 Statistics and Long-term Measurements

See also: chapter 21.2.15.4, "Long Term Measurement Results and Measurement Histogram Export", on page 928.

MEASurement<m>:STATistics[:ENABLE]..... 836
MEASurement<m>:STATistics:HISTogram..... 836
MEASurement<m>:STATistics:MODE..... 836
MEASurement<m>:STATistics:RCOunt..... 837
MEASurement<m>:STATistics:RMEascount..... 837
MEASurement<m>:STATistics:RTIME..... 837
MEASurement<m>:STATistics:RESet..... 838
MEASurement<m>:VERTical:CONT..... 838
MEASurement<m>:VERTical:AUTO..... 838
MEASurement<m>:VERTical:OFFSet..... 838
MEASurement<m>:VERTical:SCALE..... 839

MEASurement<m>:LTMeas[:STATe].....	839
MEASurement<m>:LTMeas:COUNT.....	839
MEASurement<m>:LTMeas:TIME.....	840
MEASurement<m>:LTMeas:ENVSensor:STATe.....	840

MEASurement<m>:STATistics[:ENABLE] <StatisticsState>

Enables statistics calculation for the measurement.

For details on the statistics results, see [chapter 7.2.1, "Measurements, Measurement Types, and Results"](#), on page 230.

Suffix:

<m> 1..9
See "[Measurement selection: MEASurement<m>](#)" on page 789.

Parameters:

<StatisticsState> ON | OFF
*RST: OFF

MEASurement<m>:STATistics:HISTogram <ShowHistogram>

Displays a histogram of the statistical results. Enabling the histogram enables also the calculation and display of statistics for the measurement results if statistics were disabled. the histogram shows the cumulative occurrence distribution of mean measurement results in a graphic.

Suffix:

<m> 1..9
See "[Measurement selection: MEASurement<m>](#)" on page 789.

Parameters:

<ShowHistogram> ON | OFF
*RST: OFF

MEASurement<m>:STATistics:MODE <ResetMode>

Defines when the statistics for long term measurements are reset.

Suffix:

<m> 1..9
See "[Measurement selection: MEASurement<m>](#)" on page 789.

Parameters:

<ResetMode> TIME | WFMS | MEAS

TIME

Sets one long term measurement point after the time defined using `MEASurement<m>:STATistics:RTIME`.

WFMS - Waveforms

Sets one long term measurement point after a number of acquired waveforms defined using `MEASurement<m>:STATistics:RCOUNT`.

MEAS

Sets one long term measurement point after a number of measurement results.

*RST: TIME

MEASurement<m>:STATistics:RCOUNT <RstWfmCount>

Defines the number of measured waveforms from which one point of the long term measurement is created (reset of statistics).

Suffix:

<m> 1..9

See "[Measurement selection: MEASurement<m>](#)" on page 789.

Parameters:

<RstWfmCount> Range: 1 to 65535
Increment: 10
*RST: 1000

MEASurement<m>:STATistics:RMEAscount <RstMeasCount>

Defines the number of measurement results from which one point of the long term measurement is created.

This setting is only available if `MEASurement<m>:STATistics:MODE` is set to MEAS.

Suffix:

<m> 1..9

See "[Measurement selection: MEASurement<m>](#)" on page 789.

Parameters:

<RstMeasCount> Range: 1 to 65535
Increment: 10
*RST: 1000

MEASurement<m>:STATistics:RTIME <ResetTime>

Defines the time or period after which the statistics are reset.

Suffix:

<m> 1..9
See "[Measurement selection: MEASurement<m>](#)" on page 789.

Parameters:

<ResetTime> Range: 0.1 to 2.14748E+9
Increment: 1E-3
*RST: 0.2
Default unit: s

MEASurement<m>:STATistics:RESet

Resets the histogram, the long term measurement and the statistics.

Suffix:

<m> 1..9
See "[Measurement selection: MEASurement<m>](#)" on page 789.

Usage: Event

MEASurement<m>:VERTical:CONT <AutoScale>

If enabled, automatic vertical scaling is performed whenever the waveform does not fit in the diagram during the long term measurement period.

Suffix:

<m> 1..9
See "[Measurement selection: MEASurement<m>](#)" on page 789.

Parameters:

<AutoScale> ON | OFF
*RST: ON

Firmware/Software: V 1.50

MEASurement<m>:VERTical:AUTO

If enabled, vertical scaling is adapted to the current measurement results automatically during the long term measurement period.

Suffix:

<m> 1..9
See "[Measurement selection: MEASurement<m>](#)" on page 789.

Usage: Event
SCPI confirmed

MEASurement<m>:VERTical:OFFSet <VerticalOffset>

Defines a vertical offset for the long term measurement.

Suffix:
 <m> 1..9
 See "[Measurement selection: MEASurement<m>](#)" on page 789.

Parameters:
 <VerticalOffset> Range: -100E+24 to 100E+24
 Increment: 1E-6
 *RST: 0
 Default unit: div

Usage: SCPI confirmed

MEASurement<m>:VERTical:SCALE <VerticalScale>

Defines the vertical scaling per division, so that the scaling can be adapted automatically during the long term measurement period.

Suffix:
 <m> 1..9
 See "[Measurement selection: MEASurement<m>](#)" on page 789.

Parameters:
 <VerticalScale> Range: 1E-15 to 10E+24
 Increment: 10E-6
 *RST: 0.5
 Default unit: V/div

Usage: SCPI confirmed

MEASurement<m>:LTMeas[:STATe] <ShowDiagram>

Enables long term measurement for a defined number of measurement points (see [MEASurement<m>:LTMeas:COUNT](#) on page 839) or a specified time (see [MEASurement<m>:LTMeas:TIME](#) on page 840).

Suffix:
 <m> 1..9
 See "[Measurement selection: MEASurement<m>](#)" on page 789.

Parameters:
 <ShowDiagram> ON | OFF
 *RST: OFF

MEASurement<m>:LTMeas:COUNT <MeasCount>

Defines the total number of points to be measured during the long term measurement.

Suffix:
 <m> 1..9
 See "[Measurement selection: MEASurement<m>](#)" on page 789.

Parameters:

<MeasCount> Range: 1000 to 200000
 Increment: 10
 *RST: 1000

MEASurement<m>:LTMeas:TIME <MeasurementTime>

Defines the total duration of the long term measurement.

This setting is only available if `MEASurement<m>:STATistics:MODE` is set to "Time".

Suffix:

<m> 1..9
 See "[Measurement selection: MEASurement<m>](#)" on page 789.

Parameters:

<MeasurementTime> Range: 0.01 to 2.14748E+9
 Increment: 1
 *RST: 200
 Default unit: s

MEASurement<m>:LTMeas:ENVSensor:STATE <EnvState>

Enables the evaluation of a connected environment sensor.

Suffix:

<m> 1..9
 See "[Measurement selection: MEASurement<m>](#)" on page 789.

Parameters:

<EnvState> ON | OFF
 *RST: OFF

21.2.11.10 Track and Trend

<code>MEASurement<m>:TRACK[:STATE]</code>	840
<code>MEASurement<m>:TRACK:DATA:HEADER?</code>	841
<code>MEASurement<m>:TRACK:DATA:STYPe?</code>	841
<code>MEASurement<m>:TRACK:DATA[:VALues]?</code>	841

MEASurement<m>:TRACK[:STATE] <State>

Enables the track measurement and displays the track.

See also: "[Enable \(Track\)](#)" on page 280

Suffix:

<m> 1..9
 See "[Measurement selection: MEASurement<m>](#)" on page 789.

Parameters:

<State> ON | OFF
 *RST: OFF

MEASurement<m>:TRACk:DATA:HEADer?

Returns the header of the track.

Suffix:

<m> 1..9
 See "[Measurement selection: MEASurement<m>](#)" on page 789.

Usage: Query only

MEASurement<m>:TRACk:DATA:STYPe?

Returns the data type: TRK (track)

Suffix:

<m> 1..9
 See "[Measurement selection: MEASurement<m>](#)" on page 789.

Usage: Query only

MEASurement<m>:TRACk:DATA[:VALues]?

Returns the data of track points for transmission from the instrument to the controlling computer. The data can be used in MATLAB, for example.

To set the export format, use `FORMat [: DATA]`.

Suffix:

<m> 1..9
 See "[Measurement selection: MEASurement<m>](#)" on page 789.

Usage: Query only

21.2.11.11 Results

MEASurement<m>:ARES?	842
MEASurement<m>:RESult[:ACTual]?	842
MEASurement<m>:RESult:AVG?	842
MEASurement<m>:RESult:EVTCount?	842
MEASurement<m>:RESult:NPEak?	842
MEASurement<m>:RESult:PPEak?	842
MEASurement<m>:RESult:RMS?	842
MEASurement<m>:RESult:WFMCOUNT?	842
MEASurement<m>:RESult:STDDev?	842

MEASurement<m>:ARES?

Returns the results of all selected measurements in all categories.

Suffix:

<m> 1..9
See "[Measurement selection: MEASurement<m>](#)" on page 789.

Return values:

<sData> Result string

Usage: Query only

MEASurement<m>:RESult[:ACTual]? [<MeasType>]

MEASurement<m>:RESult:AVG? [<MeasType>]

MEASurement<m>:RESult:EVTCount? [<MeasType>]

MEASurement<m>:RESult:NPEak? [<MeasType>]

MEASurement<m>:RESult:PPEak? [<MeasType>]

MEASurement<m>:RESult:RMS? [<MeasType>]

MEASurement<m>:RESult:WFMCCount? [<MeasType>]

MEASurement<m>:RESult:STDDev? [<MeasType>]

Return the specified statistic result of the specified measurement type. If no parameter is specified, the result of the main measurement is returned. The main measurement is defined using [MEASurement<m>:MAIN](#).

- [:ACTual]: current measurement result
- AVG: average of the long-term measurement results
- EVTCount: number of measurement results in the long-term measurement
- NPEak: negative peak value of the long-term measurement results
- PPEak: positive peak value of the long-term measurement results
- RMS: RMS value of the long-term measurement results
- STDDev: standard deviation of the long-term measurement results

For a detailed description of the results see [chapter 7.2.1.4, "Histograms"](#), on page 240.

Suffix:

<m> 1..9
See "[Measurement selection: MEASurement<m>](#)" on page 789.

Query parameters:

<MeasType>

Amplitude/time measurements

HIGH | LOW | AMPLitude | MAXimum | MINimum | PDELta |
 MEAN | RMS | STDDev | POVershoot | NOVershoot | AREA |
 RTIME | FTIME | PPULse | NPULse | PERiod | FREQuency |
 PDCYcle | NDCYcle | CYCarea | CYCMean | CYCRms |
 CYCStddev | PULCnt | DELay | PHASe | BWIDth | PSWitching |
 NSWitching | PULSetrain | EDGecount | SETUp | HOLD | SHR |
 DTOTrigger | PROBemeter

See [chapter 21.2.11.3, "Amplitude/Time Measurement"](#),
 on page 810.

Jitter measurements (option R&S RTO-K12)

CCJitter | NCJitter | CCWidth | CCDutycycle | TIE | UINterval |
 DRATE | SKWDelay | SKWPhase

See [chapter 21.2.20.1, "Jitter Measurements \(Option R&S RTO-K12\)"](#), on page 1075

Eye diagram measurements

ERPercent | ERDB | EHEight | EWIDth | ETOP | EBASe |
 QFACTor | RMSNoise | SNRatio | DCDistortion | ERTime |
 EFTIME | EBRate | EAMPLitude | PPJitter | STDJitter | RMSJitter

See [chapter 21.2.11.4, "Eye Diagram Measurements"](#),
 on page 819.

Spectrum measurements

CPOWER | OBWidth | SBWidth | THD | HAR

See [chapter 21.2.11.5, "Spectrum"](#), on page 821.

Histogram measurements

WCOunt | WSAMples | HSAMples | HPEak | PEAK | UPEak-
 value | LPEakvalue | HMAXimum | HMINimum | MEDian | MAX-
 Min | HMEan | HSTDdev | M1STDdev | M2STDdev | M3STDdev |
 MKPositive | MKNegative

See ["Histogram Measurement"](#) on page 830.

Example:

See ["Creating and Reading Histograms"](#) on page 1129

Usage:

Query only

21.2.11.12 Gating

MEASurement<m>:GATE[:STATe].....	844
MEASurement<m>:GATE:MODE.....	844
MEASurement<m>:GATE:ABSolute:START.....	844
MEASurement<m>:GATE:ABSolute:STOP.....	844
MEASurement<m>:GATE:RELative:START.....	844
MEASurement<m>:GATE:RELative:STOP.....	844
MEASurement<m>:GATE:NOISe.....	845
MEASurement<m>:GATE:SHOW.....	845
MEASurement<m>:GATE:ZCOupling.....	845

MEASurement<m>:GATE[:STATe] <State>

Considers the gating settings of the source waveform for the measurement.

Suffix:

<m> 1..9
See "[Measurement selection: MEASurement<m>](#)" on page 789.

Parameters:

<State> ON | OFF
*RST: OFF

MEASurement<m>:GATE:MODE <Mode>

Defines whether the gate settings are configured using absolute or relative values.

Suffix:

<m> 1..9
See "[Measurement selection: MEASurement<m>](#)" on page 789.

Parameters:

<Mode> ABS | REL
*RST: ABS

MEASurement<m>:GATE:ABSolute:START <Time>**MEASurement<m>:GATE:ABSolute:STOP <Time>**

Define the absolute start and end values for the gate.

Suffix:

<m> 1..9
See "[Measurement selection: MEASurement<m>](#)" on page 789.

Parameters:

<Time> Range: -100E+24 to 100E+24
Increment: 0.01
*RST: 0.01

Usage: SCPI confirmed

MEASurement<m>:GATE:RELative:START <RelativeStart>**MEASurement<m>:GATE:RELative:STOP <RelativeStop>**

Define the relative start and end values for the gate, respectively.

Suffix:

<m> 1..9
See "[Measurement selection: MEASurement<m>](#)" on page 789.

Parameters:

<RelativeStart> Range: 0 to 100
 <RelativeStop> Increment: 0.1
 *RST: 100
 Default unit: %

Usage: SCPI confirmed

MEASurement<m>:GATE:NOISe <NoiseEvalArea>**Suffix:**

<m> 1..9
 See "[Measurement selection: MEASurement<m>](#)" on page 789.

Parameters:

<NoiseEvalArea> UPPer | LOWer
 *RST: LOWer

MEASurement<m>:GATE:SHOW <DisplayState>

Indicates the gate area in the source diagram.

Suffix:

<m> 1..9
 See "[Measurement selection: MEASurement<m>](#)" on page 789.

Parameters:

<DisplayState> ON | OFF
 *RST: OFF

MEASurement<m>:GATE:ZCOupling <ZoomCoupling>

If enabled, the gate area is defined identically to the zoom area for the zoom diagram.

Suffix:

<m> 1..9
 See "[Measurement selection: MEASurement<m>](#)" on page 789.

Parameters:

<ZoomCoupling> ON | OFF
 *RST: OFF

21.2.11.13 Event Actions

MEASurement<m>:ONViolation:BEEP	846
MEASurement<m>:ONViolation:ACQStop	846
MEASurement<m>:ONViolation:PRINT	846
MEASurement<m>:ONViolation:WFMSave	846

MEASurement<m>:ONViolation:BEEP <Beep>

Generates a beep sound for the specified event.

Suffix:

<m> 1..9
See ["Measurement selection: MEASurement<m>"](#) on page 789.

Parameters:

<Beep> NOAction | SUCcEss | VIOLation
See [chapter 21.2.3.5, "Event Parameter"](#), on page 667
*RST: NOAction

MEASurement<m>:ONViolation:ACQStop <StopAcq>

Stops data acquisition for the specified event.

Suffix:

<m> 1..9
See ["Measurement selection: MEASurement<m>"](#) on page 789.

Parameters:

<StopAcq> NOAction | VIOLation
See [chapter 21.2.3.5, "Event Parameter"](#), on page 667
*RST: NOAction

MEASurement<m>:ONViolation:PRINT <Print>

Prints a screenshot including the measurement results to the printer defined using [SYSTem:COMMunicate:PRINter:SElect<1..2>](#) for the specified event.

Suffix:

<m> 1..9
See ["Measurement selection: MEASurement<m>"](#) on page 789.

Parameters:

<Print> NOAction | SUCcEss | VIOLation
See [chapter 21.2.3.5, "Event Parameter"](#), on page 667
*RST: NOAction

MEASurement<m>:ONViolation:WFMSave <SaveWfm>

Saves the waveform data.

Suffix:

<m> 1..9
See ["Measurement selection: MEASurement<m>"](#) on page 789.

Parameters:

<SaveWfm> NOAction | SUCCESS | VIOLation

See [chapter 21.2.3.5, "Event Parameter"](#), on page 667

*RST: NOAction

21.2.12 Mathematics

- [General Mathematics](#)..... 847
- [FFT](#)..... 849
- [Waveform Data](#)..... 861

21.2.12.1 General Mathematics

CALCulate:MATH<m>[:EXPRession][:DEFine]	847
CALCulate:MATH<m>:STATe	847
CALCulate:MATH<m>:ARITHmetics	848
CALCulate:MATH<m>:VERTical:OFFSet	848
CALCulate:MATH<m>:VERTical:RANGe	849
CALCulate:MATH<m>:VERTical:SCALE	849

CALCulate:MATH<m>[:EXPRession][:DEFine] <RemComplExpr>

Defines the math expression to be calculated for the specified math channel.

For an overview of corresponding expressions for the available keys in the Formula Editor, see [chapter 8.2.2.2, "Advanced Formula Editor"](#), on page 294.

Suffix:

<m> 1..4
Selects the math waveform.

Parameters:

<RemComplExpr> String with regular expression for calculation

Example:

CALC:MATH 'Ch1Wfm1*Ch2Wfm1 '
Defines the multiplication of waveforms Ch1Wfm1 and Ch2Wfm1.

Usage: SCPI confirmed

CALCulate:MATH<m>:STATe <State>

Enables the math waveform display.

Suffix:

<m> 1..4
math waveform

Parameters:

<State> ON | OFF
*RST: OFF

Usage: SCPI confirmed

CALCulate:MATH<m>:ARITHmetics <Arithmetics>

Selects the method to build the resulting math waveform from consecutive acquisitions. The processing is similar to the waveform arithmetics - instead of the acquired waveforms the results of the mathematic formula are used to create envelope, average and RMS.

To define the reset condition for arithmetics calculation, use [ACQUIRE:ARESet:MODE](#).

Suffix:

<m> 1..4
Selects the math waveform.

Parameters:

<Arithmetics> OFF | ENVELOpe | AVERAge | RMS
waveform arithmetic mode

OFF

The math waveform is built according to the mathematic formula.

ENVELOpe

Detects the minimum and maximum math values in an sample interval over a number of acquisitions.

AVERAge

Calculates the average from the math data of the current acquisition and a number of acquisitions before. To define the number of acquisitions, use [ACQUIRE:COUNT](#).

RMS

The resulting math waveform is the root mean square of the current acquisition and a number of acquisitions before. The result is the average power spectrum. Number of acquisitions:

[ACQUIRE:COUNT](#)

*RST: OFF

CALCulate:MATH<m>:VERTical:OFFSet <VerticalOffset>

Sets a voltage offset to adjust the vertical position of the math function on the screen.

Suffix:

<m> 1..4
math waveform

Parameters:

<VerticalOffset> Negative values move the waveform up, positive values move it down.
 Range: -100E+24 to 100E+24
 Increment: 0.01
 *RST: 0
 Default unit: div

Usage: SCPI confirmed

CALCulate:MATH<m>:VERTical:RANGe <VerticalRange>

Defines the range of FFT values to be displayed.

Suffix:

<m> 1..4
 math waveform

Parameters:

<VerticalRange> Range: 0 to 100E+24
 Increment: 0.01
 *RST: 0
 Default unit: div

Usage: SCPI confirmed

CALCulate:MATH<m>:VERTical:SCALE <VerticalScale>

Defines the scale of the y-axis in the math function diagram. The value is defined as "V per division", e.g. *50V/div*. In this case, the horizontal grid lines are displayed in intervals of 50 V.

Suffix:

<m> 1..4
 math waveform

Parameters:

<VerticalScale> Range: 1E-15 to 100E+24
 Increment: 10E-6
 *RST: 0.5
 Default unit: V/div

Usage: SCPI confirmed

21.2.12.2 FFT

CALCulate:MATH<m>:FFT:STARt.....	850
CALCulate:MATH<m>:FFT:STOP.....	850
CALCulate:MATH<m>:FFT:WINDow:TYPE.....	851
CALCulate:MATH<m>:FFT:CFRequency.....	852
CALCulate:MATH<m>:FFT:FULLspan.....	853
CALCulate:MATH<m>:FFT:SPAN.....	853

CALCulate:MATH<m>:FFT:BANDwidth[:RESolution]:ADJusted?	853
CALCulate:MATH<m>:FFT:BANDwidth[:RESolution]:AUTO	854
CALCulate:MATH<m>:FFT:BANDwidth[:RESolution]:RATio	854
CALCulate:MATH<m>:FFT:BANDwidth[:RESolution][:VALue]	854
CALCulate:MATH<m>:FFT:GATE:COUPling	854
TIMEbase:RACTime?	855
CALCulate:MATH<m>:FFT:FRAMe:ARITHmetics	855
CALCulate:MATH<m>:FFT:FRAMe:COVerge?	856
CALCulate:MATH<m>:FFT:FRAMe:MAXCount	856
CALCulate:MATH<m>:FFT:FRAMe:OFACtor	856
CALCulate:MATH<m>:FFT:GATE:ABSolute:STARt	857
CALCulate:MATH<m>:FFT:GATE:ABSolute:STOP	857
CALCulate:MATH<m>:FFT:GATE:MODE	857
CALCulate:MATH<m>:FFT:GATE:RELative:STARt	858
CALCulate:MATH<m>:FFT:GATE:RELative:STOP	858
CALCulate:MATH<m>:FFT:GATE:SHOW	858
CALCulate:MATH<m>:FFT:GATE:ZCOupling	858
CALCulate:MATH<m>:FFT:GATE[:STATe]	859
CALCulate:MATH<m>:FFT:MAGNitude:LEVel	859
CALCulate:MATH<m>:FFT:MAGNitude:RANGe	859
CALCulate:MATH<m>:FFT:MAGNitude:SCALE	860
CALCulate:MATH<m>:FFT:PHASe:SCALE	860
CALCulate:MATH<m>:FFT:PHASe:SUPPression	860
CALCulate:MATH<m>:FFT:PHASe:THReshold	861
CALCulate:MATH<m>:FFT:PHASe:UNWRap	861

CALCulate:MATH<m>:FFT:STARt <StartFreq>

Defines the start frequency of the displayed frequency span.

Suffix:

<m> 1..4
 math waveform

Parameters:

<StartFreq> start frequency
 Range: 0 to 5E+9
 Increment: 1
 *RST: 2E+9
 Default unit: Hz

CALCulate:MATH<m>:FFT:STOP <StopFreq>

Defines the stop frequency of the displayed frequency span.

Suffix:

<m> 1..4
 math waveform

Parameters:

<StopFreq> stop frequency
Range: 0 to 5E+9
Increment: 1
*RST: 2E+9
Default unit: Hz

CALCulate:MATH<m>:FFT:WINDow:TYPE <WindowType>

Windowing helps minimize the discontinuities at the end of the measured signal interval and thus reduces the effect of spectral leakage, increasing the frequency resolution.

Various different window functions are provided in the R&S RTO to suit different input signals. Each of the window functions has specific characteristics, including some advantages and some trade-offs. These characteristics need to be considered carefully to find the optimum solution for the measurement task.

Suffix:

<m> 1..4
math waveform

Parameters:

<WindowType>

RECTangular | HAMMING | HANN | BLACKharris | GAUSSian | FLATTOP2 | FLAT2 | KAISerbessel

RECTangular

The rectangular window has the best frequency resolution, but a poor amplitude accuracy and is recommended for separating two tones with almost equal amplitudes and a small frequency distance.

HAMMING

The Hamming window is bell shaped and has a good frequency resolution and fair amplitude accuracy. It is recommended for frequency response measurements as well as sine waves, periodic signals and narrow-band noise

HANN

The Hann window is bell shaped and has a slightly worse frequency resolution but smaller sidelobe level than the Hamming window. The applications are the same.

BLACKharris

The Blackman window is bell shaped and has a poor frequency resolution, but very good amplitude accuracy. It is recommended mainly for signals with single frequencies to detect harmonics.

GAUSSian

Good frequency resolution and best magnitude resolution, recommended for weak signals and short duration

FLATTOP2 | FLAT2

The flattop window has a poor frequency resolution, but the best amplitude accuracy and the sharpest side lobe. It is recommended for accurate single-tone amplitude measurements.

KAISerbessel

The Kaiser-Bessel window has a fair frequency resolution and good amplitude accuracy, and a very high sidelobe level. It is recommended for separating two tones with differing amplitudes and a small frequency distance.

*RST: BLACKharris

CALCulate:MATH<m>:FFT:CFrequency <CenterFreq>

Defines the position of the displayed frequency range, which is $(\text{Center} - \text{Span}/2)$ to $(\text{Center} + \text{Span}/2)$. The width of the range is defined using the [CALCulate:MATH<m>:FFT:SPAN](#) command.

Suffix:

<m>

1..4

math waveform

Parameters:

<CenterFreq> center frequency
 Range: 0 to 2E+12
 Increment: 1
 *RST: 2.5E+9
 Default unit: Hz

CALCulate:MATH<m>:FFT:FULLspan

Performs FFT calculation for the full frequency span.

Suffix:

<m> 1..4
 math waveform

Usage: Event

CALCulate:MATH<m>:FFT:SPAN <FreqSpan>

The span is specified in Hertz and defines the width of the displayed frequency range, which is (Center - Span/2) to (Center + Span/2). The position of the span is defined using the [CALCulate:MATH<m>:FFT:CFrequency](#) command.

Suffix:

<m> 1..4
 Math waveform

Parameters:

<FreqSpan> Frequency span
 Range: 1 to 4E+12
 Increment: 1
 *RST: 5E+9
 Default unit: Hz

CALCulate:MATH<m>:FFT:BANDwidth[:RESolution]:ADJusted?

Queries the effective resolution bandwidth.

Suffix:

<m> 1..4
 math waveform

Return values:

<AdjResBW> effective resolution bandwidth
 Range: -100E+24 to 100E+24
 *RST: 0
 Default unit: Hz

Usage: Query only

CALCulate:MATH<m>:FFT:BANDwidth[:RESolution]:AUTO <State>

Couples the frequency span to the RBW.

Suffix:

<m> 1..4
math waveform

Parameters:

<State> ON | OFF
*RST: ON

CALCulate:MATH<m>:FFT:BANDwidth[:RESolution]:RATio <SpanRBWRatio>

This command defines the ratio of span (Hz) / resolution bandwidth (Hz).

Suffix:

<m> 1..4
math waveform

Parameters:

<SpanRBWRatio> ratio span / resolution bandwidth
Range: 1 to 1000
Increment: 1
*RST: 100

CALCulate:MATH<m>:FFT:BANDwidth[:RESolution][:VALue] <ResolutionBW>

This command defines the resolution bandwidth.

Suffix:

<m> 1..4
math waveform

Parameters:

<ResolutionBW> resolution bandwidth
Range: 0.01 to 2E+6
Increment: 0.01
*RST: 2E+6
Default unit: Hz

CALCulate:MATH<m>:FFT:GATE:COUPling <GateRBWCoupling>

Defines the behaviour of the record length or RBW value in dependency to the other FFT parameters.

See also:

- ["Record Length/RBW Coupling"](#) on page 315
- [chapter 8.3.1, "Fundamentals of FFT Analysis"](#), on page 298

Suffix:

<m> 1...4
math waveform

Parameters:

<GateRBWCoupling> LENGth | RBW

LENGth

The record length remains constant. If not enough samples are available for the selected RBW, the RBW will be decreased.

RBW

The RBW is not adapted, i.e. remains as defined by the user. The required acquisition time for this RBW is indicated. If necessary and possible, the record length is extended to acquire the required number of samples.

*RST: RBW

Usage: SCPI confirmed

TIMEbase:RACTime?

Queries the required acquisition time. If FFT gating is used and the resolution BW is set to constant, record length can be extended to acquire the required number of samples. In this case, the required acquisition time differs from the adjusted acquisition time ([TIMEbase:RANGe](#)).

Return values:

<RequiredAcqTime> Required acquisition time for FFT
Range: 250E-12 to 500
*RST: 0.5
Default unit: s

Usage: Query only

CALCulate:MATH<m>:FFT:FRAME:ARITHmetics <Arithmetics>

The arithmetic mode defines how the final FFT result is calculated from the individual frame results.

Suffix:

<m> 1..4
Selects the math waveform.

Parameters:

<Arithmetics> OFF | ENVELOpe | AVERAge | RMS
See "[Frame Arithmetics](#)" on page 308
*RST: OFF

CALCulate:MATH<m>:FFT:FRAME:COVerge?

Due to the restriction of the number of frames (see [CALCulate:MATH<m>:FFT:FRAME:MAXCount](#) on page 856), the waveform may only be analyzed partially. This command queries the percentage of the trace that was analyzed, i.e. which part of the trace was included in the frame calculation.

Suffix:

<m> 1...4
math waveform

Return values:

<FrameCoverage> Range: 0 to 100
*RST: 100
Default unit: %

Usage:

Query only
SCPI confirmed

CALCulate:MATH<m>:FFT:FRAME:MAXCount <MaxFrameCount>

Restricts the maximum number of frames to be calculated. Due to the other parameter settings, the required number of frames may become very high, thus slowing performance. By restricting the number of frames, you can avoid performance loss without changing the other parameters.

Suffix:

<m> 1...4
math waveform

Parameters:

<MaxFrameCount> Range: 1 to 10000
Increment: 10
*RST: 1000

Usage:

SCPI confirmed

CALCulate:MATH<m>:FFT:FRAME:OFACtor <OverlapFactor>

Defines the minimum factor by which two neighboring frames overlap. If the required number of frames to cover the input values allows for more overlap, the factor is increased.

The higher the overlap factor, the more frames are used. This leads to more individual results and improves detection of transient signal effects. However, it also extends the duration of the calculation.

Suffix:

<m> 1...4
math waveform

Parameters:

<OverlapFactor> Range: 0 to 90
 Increment: 1
 *RST: 50
 Default unit: %

Usage: SCPI confirmed

CALCulate:MATH<m>:FFT:GATE:ABSolute:START <Start>

Defines the starting value for the gate.

Suffix:

<m> 1...4
 math waveform

Parameters:

<Start> Range: -100E+24 to 100E+24
 Increment: 0.01
 *RST: 0.01

Usage: SCPI confirmed

CALCulate:MATH<m>:FFT:GATE:ABSolute:STOP <Stop>

Defines the end value for the gate.

Suffix:

<m> 1...4
 math waveform

Parameters:

<Stop> Range: -100E+24 to 100E+24
 Increment: 0.01
 *RST: 0.01

Usage: SCPI confirmed

CALCulate:MATH<m>:FFT:GATE:MODE <Mode>

Defines whether the gate settings are configured using absolute or relative values.

Suffix:

<m> 1...4
 math waveform

Parameters:

<Mode> ABS | REL
 *RST: ABS

Usage: SCPI confirmed

CALCulate:MATH<m>:FFT:GATE:RELative:START <RelativeStart>

Defines the starting value for the gate in percent.

Suffix:

<m> 1...4
 math waveform

Parameters:

<RelativeStart> Range: -100E+24 to 100E+24
 Increment: 0.1
 *RST: 0
 Default unit: %

Usage: SCPI confirmed

CALCulate:MATH<m>:FFT:GATE:RELative:STOP <RelativeStop>

Defines the end value for the gate in percent.

Suffix:

<m> 1...4
 math waveform

Parameters:

<RelativeStop> Range: -100E+24 to 100E+24
 Increment: 0.1
 *RST: 100
 Default unit: %

Usage: SCPI confirmed

CALCulate:MATH<m>:FFT:GATE:SHOW <DisplayState>

Indicates the gate area in the source diagram.

Suffix:

<m> 1...4
 math waveform

Parameters:

<DisplayState> ON | OFF
 *RST: OFF

Usage: SCPI confirmed

CALCulate:MATH<m>:FFT:GATE:ZCOupling <ZoomCoupling>

If enabled, the gate area is defined identically to the zoom area for the zoom diagram.

Suffix:

<m> 1...4
 math waveform

Parameters:
 <ZoomCoupling> ON | OFF
 *RST: OFF
Usage: SCPI confirmed

CALCulate:MATH<m>:FFT:GATE[:STATE] <State>

Enables FFT gating.

Suffix:
 <m> 1...4
 math waveform

Parameters:
 <State> ON | OFF
 *RST: OFF

Usage: SCPI confirmed

CALCulate:MATH<m>:FFT:MAGNitude:LEVel <VerticalMax>

Defines the reference level for dB scaling.

Suffix:
 <m> 1..4
 math waveform

Parameters:
 <VerticalMax> Range: -100E+24 to 100E+24
 Increment: 0.01
 *RST: 0
 Default unit: div

Usage: SCPI confirmed

CALCulate:MATH<m>:FFT:MAGNitude:RANGe <Range>

Defines the vertical value range in spectrum mode.

Suffix:
 <m> 1...4
 math waveform

Parameters:
 <Range> Range: 1 to 500
 Increment: 1
 *RST: 100
 Default unit: dB

Usage: SCPI confirmed

CALCulate:MATH<m>:FFT:MAGNitude:SCALE <MagnitudeScale>

Defines the scaling of the y-axis. The display values are valid for 50Ω termination impedance.

For details on the available scaling modes, see "[Magnitude unit](#)" on page 310.

Suffix:

<m> 1..4
math waveform

Parameters:

<MagnitudeScale> LINear | DBM | DB | DBUV | DBMV | DBV | DBPS | DBNS | DBUS | DBMS | DBS | DBHZ | DBKHZ | DBMHZ | DBGHZ

LINear

linear scaling; displays the RMS value of the voltage

DBM | DB | DBUV | DBMV | DBV | DBPS | DBNS | DBUS | DBMS | DBS | DBHZ | DBKHZ | DBMHZ | DBGHZ

logarithmic scaling: dBm, dB (related to reference level), dBμV, dBmV, dBV, dBps, dBns, dBμs, dBms, dBs, dBHz, dBkHz, dBMHz, dbGHz

*RST: DBM

Usage: SCPI confirmed

CALCulate:MATH<m>:FFT:PHASe:SCALE <PhaseScale>

Defines the scaling unit for phase display.

Suffix:

<m> 1...4
math waveform

Parameters:

<PhaseScale> DEGRees | RADians
*RST: DEGRees

Usage: SCPI confirmed

CALCulate:MATH<m>:FFT:PHASe:SUPPression <Suppression>

Enables noise suppression. Phase calculation is restricted to frequencies with a minimum magnitude, the threshold value (see [CALCulate:MATH<m>:FFT:PHASe:THReshold](#) on page 861).

Suffix:

<m> 1...4
math waveform

Parameters:

<Suppression> ON | OFF
*RST: OFF

Usage: SCPI confirmed

CALCulate:MATH<m>:FFT:PHASe:THReshold <SupprThres>

Defines the minimum frequency magnitude for which phases are calculated. This setting is only available if `CALCulate:MATH<m>:FFT:PHASe:SUPPReSSion` is set to "ON".

Suffix:

<m> 1...4
math waveform

Parameters:

<SupprThres> Range: -180 to 180
Increment: 0.1
*RST: 0
Default unit: dBm

Usage: SCPI confirmed

CALCulate:MATH<m>:FFT:PHASe:UNWRap <Unwrap>

If enabled, phase shifts due to a limitation of the value range are eliminated.

Suffix:

<m> 1...4
math waveform

Parameters:

<Unwrap> ON | OFF
*RST: OFF

Usage: SCPI confirmed

21.2.12.3 Waveform Data

<code>CALCulate:MATH<m>:DATA:STYPe?</code>	861
<code>CALCulate:MATH<m>:DATA:HEADer?</code>	862
<code>CALCulate:MATH<m>:DATA[:VALues]?</code>	862

CALCulate:MATH<m>:DATA:STYPe?

Returns the signal type of the source of the math waveform.

Suffix:

<m> 1..4
Selects the math waveform.

Return values:

<SignalType> SOUR | SPEC | CORR | MEAS | NONE
 SOURce = normal signal
 SPECtrum = FFT spectrum, specific math signal
 CORRelation = correlated signal, specific math signal
 MEAsurement = result of a measurement
 XY = XY-signal
 SBUS = Serial bus
 NONE = undefined

Usage:

Query only
 SCPI confirmed

CALCulate:MATH<m>:DATA:HEADer?

Returns the header of math waveform data. The header contains attributes of the waveform.

Table 21-19: Header data

Position	Meaning	Example
1	XStart in s	-9.477E-008 = - 94,77 ns
2	XStop in s	9.477E-008 = 94,77 ns
3	Record length of the waveform in Samples	200000
4	Number of values per sample interval. For most waveforms the result is 1, for peak detect and envelope waveforms it is 2. If the number is 2, the number of returned values is twice the number of samples (record length).	1

Suffix:

<m> 1..4
 Selects the math waveform.

Example:

CALC:MATH4:DATA:HEAD
 -9.477E-008,9.477E-008,200000,1

Usage:

Query only
 SCPI confirmed

CALCulate:MATH<m>:DATA[:VALues]?

Returns the data of the math waveform points for transmission from the instrument to the controlling computer. The data can be used in MATLAB, for example.

To set the export format, use [FORMat \[:DATA\]](#).

You can retrieve only Y-values, or X- and Y-values. Use [EXPort:WAVEform:INCXvalues](#) to define this.

Suffix:	
<m>	1..4 Selects the math waveform.
Return values:	
<Data>	List of values according to the format and content settings.
Usage:	Query only

21.2.13 Mask Testing

• Mask Test Definition	863
• Mask Definition: User Mask	867
• Mask Definition: Waveform Mask	872
• Event Actions	874
• Results	875

21.2.13.1 Mask Test Definition

MTEST:ADD	863
MTEST:REMOve	863
MTEST[:STATe]	864
MTEST:RST	864
MTEST:SOURce	864
MTEST:CONDition	864
MTEST:TOLerance	865
MTEST:CTYPe	865
MTEST:FILE:NAME	866
MTEST:FILE:SAVE	866
MTEST:FILE:OPEN	866
MTEST:FILE:DELeTe	867

MTEST:ADD <MaskTestName>

Creates a new mask test definition with the specified name.

Setting parameters:

<MaskTestName> String with the name of the mask test

Example: See [chapter 21.3.3.1, "Creating a user mask"](#), on page 1130

Usage: Setting only

MTEST:REMOve <MaskTestName>

Deletes the mask test definition with the specified name.

Setting parameters:

<MaskTestName> String with the name of the mask test

Usage: Setting only

MTESt[:STATe] <MaskTestName>,<State>

MTESt[:STATe]? <MaskTestName>

Activates and deactivates the mask test. If the acquisition is running, the test starts immediately. Otherwise, the test starts when acquisition is started.

The testing is stopped when acquisition is stopped, also due to the [MTESt:ONViolation:STOP](#) command, or if [MASK\[:STATe\]](#) is set to "OFF".

Parameters:

<State> ON | OFF
 *RST: OFF

Parameters for setting and query:

<MaskTestName> String with the name of the mask test

Example: See [chapter 21.3.3.1, "Creating a user mask"](#), on page 1130

MTESt:RST

Clears all totals and results in all "Mask Test" result boxes.

Usage: Event

Firmware/Software: FW 1.35

MTESt:SOURce <MaskTestName>,<MaskTestSource>

MTESt:SOURce? <MaskTestName>

Selects the waveform to be tested against the mask. All channel waveforms can be tested.

Parameters:

<MaskTestSource> NONE | C1W1 | C1W2 | C1W3 | C2W1 | C2W2 | C2W3 | C3W1 |
 C3W2 | C3W3 | C4W1 | C4W2 | C4W3

Waveform to be tested, see [chapter 21.2.3.2, "Waveform Parameter"](#), on page 666

*RST: NONE

Parameters for setting and query:

<MaskTestName> String containing the name of the mask test

MTESt:CONDition <MaskTestName>,<PassFailMode>

MTESt:CONDition? <MaskTestName>

Sets the first criteria for a failed test, the kind of hits to be considered for test evaluation. A test has failed if the number of sample hits or acquisition hits exceeds the limit defined by [MTESt:TOLerance](#).

Parameters:

<PassFailMode> SAMPlEs | ACQuisitions

SAMPlEs

Considers the number of samples that hit the mask.

ACQuisitions

Considers the number of acquisitions that contain at least one sample hit. How many samples hit the mask in that acquisition is not relevant.

*RST: SAMPlEs

Parameters for setting and query:

<MaskTestName> String with the name of the mask test

MTESt:TOLerance <MaskTestName>,<ToViolCount>

MTESt:TOLerance? <MaskTestName>

Sets the second criteria for a failed test, the number of tolerable sample hits or acquisition hits. Use **MTESt:CONDition** to define which hits are considered for test evaluation.

Parameters:

<ToViolCount> Range: 0 to 4000000000
 Increment: 1
 *RST: 0

Parameters for setting and query:

<MaskTestName> String with the name of the mask test

MTESt:CTYPe <MaskTestName>,<DefinitionType>

MTESt:CTYPe? <MaskTestName>

Sets the method of mask definition.

Parameters:

<DefinitionType> USER | WFML | EYEMask

USER

The mask segments are created by entering the numerical x- and y-values of the mask points.

See: [chapter 21.2.13.2, "Mask Definition: User Mask"](#), on page 867

WFML

The mask is created from the envelope of an existing waveform.

See: [chapter 21.2.13.3, "Mask Definition: Waveform Mask"](#), on page 872

EYEMask

Mask for eye diagram testing. This mask type is available if option R&S RTO-K12 is installed.

See: [chapter 21.2.20.5, "Eye Mask Testing \(Option R&S RTO-K12\)"](#), on page 1086...

*RST: USER

Parameters for setting and query:

<MaskTestName> String with the name of the mask test

MTESt:FILE:NAME <MaskTestName>, <Path>

MTESt:FILE:NAME? <MaskTestName>

Specifies a file to save the mask test.

Parameters:

<Path> String containing path and file name, format .xml

Parameters for setting and query:

<MaskTestName> String with the name of the mask test

MTESt:FILE:SAVE <MaskTestName>

Saves the specified mask test. It contains the mask definition, defined actions and fail conditions.

Setting parameters:

<MaskTestName> String with the name of the mask test

Usage: Setting only

MTESt:FILE:OPEN <MaskTestName>

Loads the specified mask test to the instrument.

Setting parameters:

<MaskTestName> String with the name of the mask test

Usage: Setting only

MTESt:FILE:DELeTe <MaskTestName>

Deletes the specified mask test.

Setting parameters:

<MaskTestName> String with the name of the mask test

Usage: Setting only

21.2.13.2 Mask Definition: User Mask

The chapter contains commands required for the definition of user masks - [MTESt:CTYPe](#) is set to `USER`.

**Segment and point indices**

In remote control, the numbering of segments and points starts from 0. But in manual operation, the numbering starts from 1.

MTESt:SEGMENT:STATE	867
MTESt:SEGMENT:ADD	868
MTESt:SEGMENT:COUNT?	868
MTESt:SEGMENT:INSert	868
MTESt:SEGMENT:REMove	868
MTESt:SEGMENT:REGion	868
MTESt:SEGMENT:POINT:ADD	869
MTESt:SEGMENT:POINT:INSert	869
MTESt:SEGMENT:POINT:REMove	869
MTESt:SEGMENT:POINT:COUNT?	870
MTESt:SEGMENT:POINT:X	870
MTESt:SEGMENT:POINT:Y	870
MTESt:SEGMENT:RESCale:RECalculate	871
MTESt:SEGMENT:RESCale:XFACTOR	871
MTESt:SEGMENT:RESCale:YFACTOR	871
MTESt:SEGMENT:RESCale:XOFFset	871
MTESt:SEGMENT:RESCale:YOFFset	872

MTESt:SEGMENT:STATE <MaskTestName>, <MaskSegIdx>,<State>

MTESt:SEGMENT:STATE? <MaskTestName>, <MaskSegIdx>

Enables and disables the mask segment. Disabled segments are not considered by running tests.

Parameters:

<State> ON | OFF
*RST: ON

Parameters for setting and query:

<MaskTestName> String with the name of the mask test

<MaskSegIdx> Number of the segment. Counting starts from 0.

MTESt:SEGMENT:ADD <MaskTestName>

Creates a new segment in the mask definition.

Setting parameters:

<MaskTestName> String with the name of the mask test

Example: See [chapter 21.3.3.1, "Creating a user mask"](#), on page 1130

Usage: Setting only

MTESt:SEGMENT:COUNT? <MaskTestName>

Returns the number of segments in the mask definition

Query parameters:

<MaskTestName> String with the name of the mask test

Return values:

<Count> Number of segments

Usage: Query only

MTESt:SEGMENT:INSERT <MaskTestName>, <MaskSegIdx>

Inserts a new segment before the specified index in the mask definition.

Setting parameters:

<MaskTestName> String with the name of the mask test

<MaskSegIdx> Number of the segment. Counting starts from 0.

Usage: Setting only

MTESt:SEGMENT:REMOVE <MaskTestName>, <MaskSegIdx>

Removes the specified segment from the mask definition.

Setting parameters:

<MaskTestName> String with the name of the mask test

<MaskSegIdx> Number of the segment. Counting starts from 0.

Usage: Setting only

MTESt:SEGMENT:REGION <MaskTestName>, <MaskSegIdx>, <Region>**MTESt:SEGMENT:REGION?** <MaskTestName>, <MaskSegIdx>

Defines the region of the segment that builds the mask.

Parameters:

<Region> UPPer | LOWer | INNer

UPPer

the segment points are connected to a line, the display area above this line is the mask segment

LOWer

the segment points are connected to a line, the display area below this line is the mask segment

INNer

the segment points form a closed geometrical shape, which is the mask segment

*RST: INNer

Parameters for setting and query:

<MaskTestName> String with the name of the mask test

<MaskSegIdx> Number of the segment. Counting starts from 0.

Example: See [chapter 21.3.3.1, "Creating a user mask"](#), on page 1130

MTESt:SEGment:POINT:ADD <MaskTestName>, <MaskSegIdx>

Adds a new point to the segment definition.

Setting parameters:

<MaskTestName> String with the name of the mask test

<MaskSegIdx> Number of the segment. Counting starts from 0.

Example: See [chapter 21.3.3.1, "Creating a user mask"](#), on page 1130

Usage: Setting only

MTESt:SEGment:POINT:INSert <MaskTestName>, <MaskSegIdx>, <MaskSegPointIdx>

Inserts a new point before the specified mask segment point.

Setting parameters:

<MaskTestName> String with the name of the mask test

<MaskSegIdx> Number of the segment. Counting starts from 0.

<MaskSegPointIdx> Number of the point. Counting starts from 0.

Usage: Setting only

MTESt:SEGment:POINT:REMOve <MaskTestName>, <MaskSegIdx>, <MaskSegPointIdx>

Removes the specified point from the mask segment.

Setting parameters:

<MaskTestName> String with the name of the mask test
 <MaskSegIdx> Number of the segment. Counting starts from 0.
 <MaskSegmPointIdx> Number of the point. Counting starts from 0.

Usage: Setting only

MTES:SEGMent:POINT:COUNT? <MaskTestName>, <MaskSegIdx>

Returns the number of defined points for the specified mask segment.

Query parameters:

<MaskTestName> String with the name of the mask test
 <MaskSegIdx> Number of the segment. Counting starts from 0.

Usage: Query only

MTES:SEGMent:POINT:X <MaskTestName>, <MaskSegIdx>,
 <MaskSegmPointIdx>, <X>

MTES:SEGMent:POINT:X? <MaskTestName>, <MaskSegIdx>,
 <MaskSegmPointIdx>

Defines the x-value of the mask segment point.

Parameters:

<X> Range: -100E+24 to 100E+24
 Increment: 1E-6
 *RST: 0
 Default unit: s

Parameters for setting and query:

<MaskTestName> String with the name of the mask test
 <MaskSegIdx> Number of the segment. Counting starts from 0.
 <MaskSegmPointIdx> Number of the point. Counting starts from 0.

Example: See [chapter 21.3.3.1, "Creating a user mask"](#), on page 1130

MTES:SEGMent:POINT:Y <MaskTestName>, <MaskSegIdx>,
 <MaskSegmPointIdx>, <Y>

MTES:SEGMent:POINT:Y? <MaskTestName>, <MaskSegIdx>,
 <MaskSegmPointIdx>

Defines the y-value of the mask segment point.

Parameters:

<Y> Range: -100E+24 to 100E+24
 Increment: 1E-6
 *RST: 0
 Default unit: V

Parameters for setting and query:

- <MaskTestName> String with the name of the mask test
- <MaskSegIdx> Number of the segment. Counting starts from 0.
- <MaskSegmPointIdx> Number of the point. Counting starts from 0.

Example: See [chapter 21.3.3.1, "Creating a user mask"](#), on page 1130

MTESt:SEGMENT:RESCale:RECalculate <MaskTestName>, <MaskSegIdx>

Multiplies and adds the given x- and y-factors and offsets to the coordinates of all points of the selected mask segment.

Setting parameters:

- <MaskTestName> String with the name of the mask test
- <MaskSegIdx> Number of the segment. Counting starts from 0.

Usage: Setting only

MTESt:SEGMENT:RESCale:XFACTOR <MaskTestName>, <MaskSegIdx>, <ExpansionFactor>**MTESt:SEGMENT:RESCale:XFACTOR?** <MaskTestName>, <MaskSegIdx>**MTESt:SEGMENT:RESCale:YFACTOR** <MaskTestName>, <MaskSegIdx>, <ExpansionFactor>**MTESt:SEGMENT:RESCale:YFACTOR?** <MaskTestName>, <MaskSegIdx>

Stretches or compresses the selected mask segment in horizontal (XFACTOR) or vertical direction (YFACTOR). The x- or y-values of all points of the selected mask segment are multiplied with this factor. Factors >1 stretch the mask segment, while factors between 0 and 1 compress it. Negative values are possible and change the algebraic sign.

Only takes effect after the [MTESt:SEGMENT:RESCale:RECalculate](#) command.

Parameters:

- <ExpansionFactor> Range: -100 to 100
Increment: 1
*RST: 1

Parameters for setting and query:

- <MaskTestName> String with the name of the mask test
- <MaskSegIdx> Number of the segment. Counting starts from 0.

MTESt:SEGMENT:RESCale:XOFFSET <MaskTestName>, <MaskSegIdx>, <OffsetX>**MTESt:SEGMENT:RESCale:XOFFSET?** <MaskTestName>, <MaskSegIdx>

Moves the mask segment horizontally. The specified offset is added to the x-values of all points of the selected mask segment.

Only takes effect after the [MTESt:SEGMENT:RESCale:RECalculate](#) command.

Parameters:

<OffsetX> Range: -50 to 50
 Increment: 1E-9
 *RST: 0
 Default unit: s

Parameters for setting and query:

<MaskTestName> String with the name of the mask test
 <MaskSegIdx> Number of the segment. Counting starts from 0.

Firmware/Software: V 1.25

MTESt:SEGment:RESCale:YOffset <MaskTestName>, <MaskSegIdx>, <OffsetY>
MTESt:SEGment:RESCale:YOffset? <MaskTestName>, <MaskSegIdx>

Moves the mask segment vertically. The specified offset is added to the y-values of all points of the selected mask segment.

Only takes effect after the [MTESt:SEGment:RESCale:RECalculate](#) command.

Parameters:

<OffsetY> Range: -1000 to 1000
 Increment: 1E-6
 *RST: 0
 Default unit: V

Parameters for setting and query:

<MaskTestName> String with the name of the mask test
 <MaskSegIdx> Number of the segment. Counting starts from 0.

21.2.13.3 Mask Definition: Waveform Mask

The chapter contains commands required for the definition of waveform masks -
[MTESt:CTYPe](#) is set to `WFML`.

MTESt:REFWfm	872
MTESt:WFMLupdate	873
MTESt:WFMRRescale:XWIDth	873
MTESt:WFMRRescale:YWIDth	873
MTESt:WFMRRescale:YPOSition	874
MTESt:WFMRRescale:YSTRetch	874

MTESt:REFWfm <MaskTestName>,<Source>
MTESt:REFWfm? <MaskTestName>

Sets the reference waveform from which the mask is created.

The reference waveform can be created before, or loaded from a file with [REFCurve](#) commands, see [chapter 21.2.9.1, "Reference"](#), on page 775.

Parameters:

<Source> REF1 | REF2 | REF3 | REF4
 *RST: REF1

Parameters for setting and query:

<MaskTestName> String containing the name of the mask test

MTESt:WFMLupdate <MaskTestName>

Creates the upper and lower mask limit from the envelope of the selected reference waveform. If the reference waveform was not defined before, it is created automatically from the mask test source waveform which is set with `MTESt:SOURce`.

Setting parameters:

<MaskTestName> String containing the name of the mask test

Usage: Setting only

MTESt:WFMRescale:XWIDTH <MaskTestName>,<HorizontalWidth>**MTESt:WFMRescale:XWIDTH?** <MaskTestName>

Sets the width of the mask in horizontal direction. The specified factor in divisions is added to the positive x-values and subtracted from the negative x-values of the mask limits in relation to the source waveform of the mask.

Parameters:

<HorizontalWidth> Range: 0 to 1000
 Increment: 0.01
 *RST: 0
 Default unit: div

Parameters for setting and query:

<MaskTestName> String containing the name of the mask test

MTESt:WFMRescale:YWIDTH <MaskTestName>,<VerticalWidth>**MTESt:WFMRescale:YWIDTH?** <MaskTestName>

Sets the width of the waveform mask in vertical direction. The specified factor in divisions is added to the y-values of the upper mask limit and subtracted from the y-values of the lower mask limit. Thus, the upper half of the mask is pulled upwards, the lower half is pulled down.

Parameters:

<VerticalWidth> Vertical mask width in divisions
 Range: 0 to 1000
 Increment: 0.01
 *RST: 0
 Default unit: div

Parameters for setting and query:

<MaskTestName> String containing the name of the mask test

MTESt:WFMRescale:YPOSITION <MaskTestName>,<VertPosi>
MTESt:WFMRescale:YPOSITION? <MaskTestName>

Moves the mask vertically within the display.

Parameters:

<VertPosi> Range: -1000 to 1000
 Increment: 0.01
 *RST: 0
 Default unit: div

Parameters for setting and query:

<MaskTestName> String containing the name of the mask test

MTESt:WFMRescale:YSTRetch <MaskTestName>,<VerticalStretch>
MTESt:WFMRescale:YSTRetch? <MaskTestName>

Sets the vertical scaling to stretch the mask in y-direction. The scaling axis is the horizontal line through the lowest value of the lower mask limit.

Parameters:

<VerticalStretch> Scale factor in %
 Range: 10 to 1000
 Increment: 1
 *RST: 100
 Default unit: %

Parameters for setting and query:

<MaskTestName> String containing the name of the mask test

21.2.13.4 Event Actions

MTESt:ONViolation:BEEP.....	874
MTESt:ONViolation:STOP.....	875
MTESt:ONViolation:PRINT.....	875
MTESt:ONViolation:SAVewaveform.....	875

MTESt:ONViolation:BEEP <MaskTestName>,<Beep>
MTESt:ONViolation:BEEP? <MaskTestName>

Generates a beep sound for the specified event.

Parameters:

<Beep> NOAction | SUCCess | VIOLation
 See [chapter 21.2.3.5, "Event Parameter"](#), on page 667
 *RST: NOAction

Parameters for setting and query:

<MaskTestName> String with the name of the mask test

MTEST:ONViolation:STOP <MaskTestName>,<StopAcq>

MTEST:ONViolation:STOP? <MaskTestName>

Stops data acquisition for the specified event.

Parameters:

<StopAcq> NOAction | VIOLation

See [chapter 21.2.3.5, "Event Parameter"](#), on page 667

*RST: NOAction

Parameters for setting and query:

<MaskTestName> String with the name of the mask test

MTEST:ONViolation:PRINT <MaskTestName>,<Print>

MTEST:ONViolation:PRINT? <MaskTestName>

Prints a screenshot including the measurement results to the printer defined using [SYSTEM:COMMunicate:PRINter:SElect<1..2>](#) for the specified event.

Parameters:

<Print> NOAction | SUCCess | VIOLation

See [chapter 21.2.3.5, "Event Parameter"](#), on page 667

*RST: NOAction

Parameters for setting and query:

<MaskTestName> String with the name of the mask test

MTEST:ONViolation:SAVewaveform <MaskTestName>,<SaveWfm>

MTEST:ONViolation:SAVewaveform? <MaskTestName>

Saves the waveform data.

Parameters:

<SaveWfm> NOAction | SUCCess | VIOLation

See [chapter 21.2.3.5, "Event Parameter"](#), on page 667

*RST: NOAction

Parameters for setting and query:

<MaskTestName> String with the name of the mask test

21.2.13.5 Results

MTEST:RESult:STATe?	876
MTEST:RESult[:RESult]?	876
MTEST:RESult:COUNt:WAVEforms?	876
MTEST:RESult:COUNt:REMAining?	876
MTEST:RESult:COUNt:FWAVEforms?	877
MTEST:RESult:COUNt:FAILures?	877
MTEST:RESult:FRATe?	877

MTESt:RESult:STATe? <MaskTestName>

Shows if the test is running or has finished. The state is set to "Finished" if no acquisitions remain (see [MTESt:RESult:COUNt:REMaining?](#) on page 876).

Query parameters:

<MaskTestName>

Return values:

<State> RUNNING | FINISHED
*RST: RUNNING

Usage: Query only

MTESt:RESult[:RESult]? <MaskTestName>

Returns the test result.

A test has failed if the number of sample hits or acquisition hits exceeds the limit of "Violation tolerance" hits (see [MTESt:TOLerance](#) on page 865, [MTESt:RESult:COUNt:FAILures?](#) on page 877 and [MTESt:RESult:COUNt:FWAVEforms?](#) on page 877).

Query parameters:

<MaskTestName>

Return values:

<TestResult> PASS | FAIL
*RST: PASS

Usage: Query only

MTESt:RESult:COUNt:WAVEforms? <MaskTestName>

Returns the number of tested acquisitions.

Query parameters:

<MaskTestName>

Return values:

<AcqsCompleted> Range: 0 to 100E+24
*RST: 0

Usage: Query only

MTESt:RESult:COUNt:REMaining? <MaskTestName>

Remaining acquisitions until "Average count / Nx Single count" is reached.

The value is useful if you test a specified number of acquisitions with action "Stop acquisition" on violation, or if the acquisition has been stopped manually.

See also: [chapter 9.2.4, "Running a Mask Test"](#), on page 324.

Query parameters:

<MaskTestName>

Return values:

<AcqsRemaining> Range: 0 to 100E+24
 *RST: 0

Usage: Query only**MTESt:RESult:COUNt:FWAVeforms? <MaskTestName>**

Returns the number of acquisitions that contained at least one sample hit.

Query parameters:

<MaskTestName>

Return values:

<AcquisitionHits> Range: 0 to 100E+24
 *RST: 0

Usage: Query only**MTESt:RESult:COUNt:FAILures? <MaskTestName>**

Returns the number of sample hits that violated the mask.

Query parameters:

<MaskTestName>

Return values:

<SampleHits> Range: 0 to 100E+24
 *RST: 0

Usage: Query only**MTESt:RESult:FRATe? <MaskTestName>**

Ratio of acquisition hits to the number of tested acquisitions.

Query parameters:

<MaskTestName>

Return values:

<FailRate> Range: -100E+24 to 100E+24
 *RST: 0
 Default unit: %

Usage: Query only

21.2.14 Search

• General Search Settings.....	878
• Basic Trigger Search Conditions.....	880
• Edge Search Conditions.....	882
• Glitch Search Conditions.....	882
• Interval Search Conditions.....	883
• Runt Search Conditions.....	885
• Slew Rate Search Conditions.....	887
• Timeout Search Conditions.....	889
• Width Search Conditions.....	890
• Window Search Conditions.....	892
• Data2Clock Search Conditions.....	894
• Pattern Search Conditions.....	896
• State Search Conditions.....	900
• Search Scope Settings.....	903
• Noise Rejection.....	906
• Search Results.....	907

21.2.14.1 General Search Settings

SEARch:ADD.....	878
SEARch:CLEAr.....	878
SEARch:REMOve.....	879
SEARch:SOURce.....	879
SEARch:ONLine.....	879
SEARch:ALL.....	879

SEARch:ADD <SearchName>

Creates a new search definition with the specified name.

Setting parameters:

<SearchName> String with the name of the search

Example: See [chapter 21.3.4.1, "Searching for a pulse of specified width"](#), on page 1131

Usage: Setting only

SEARch:CLEAr <SearchName>

Clears the search results once to start a new search.

Setting parameters:

<SearchName> Search definition

Usage: Setting only

SEARCh:REMOve <SearchName>

Deletes the specified search definition.

Setting parameters:

<SearchName> String with the name of the search

Usage: Setting only

SEARCh:SOURce <SearchName>,<Source>**SEARCh:SOURce?** <SearchName>

Defines the source on which the search conditions are applied. The source can be any analog or digital channel, math or reference waveform.

Parameters:

<Source> C1W1 | C1W2 | C1W3 | C2W1 | C2W2 | C2W3 | C3W1 | C3W2 |
C3W3 | C4W1 | C4W2 | C4W3 | M1 | M2 | M3 | M4 | R1 | R2 |
R3 | R4 | D0 | D1 | D2 | D3 | D4 | D5 | D6 | D7 | D8 | D9 | D10 |
D11 | D12 | D13 | D14 | D15 | TRK1 | TRK2 | TRK3 | TRK4 |
TRK5 | TRK6 | TRK7 | TRK8

Source of the search, see [chapter 21.2.3.2, "Waveform Parameter"](#), on page 666

*RST: NONE

Parameters for setting and query:

<SearchName> String with the name of the search

Example: See [chapter 21.3.4.1, "Searching for a pulse of specified width"](#), on page 1131

SEARCh:ONLine <SearchName>,<OnlineState>**SEARCh:ONLine?** <SearchName>

If enabled, a search is performed repeatedly for each new data acquisition.

Parameters:

<OnlineState> ON | OFF

*RST: OFF

Parameters for setting and query:

<SearchName> Search definition

SEARCh:ALL <SearchName>

Performs a search for all results on the existing data from the selected source.

Setting parameters:

<SearchName> Search definition

Example: See [chapter 21.3.4.1, "Searching for a pulse of specified width"](#), on page 1131

Usage: Setting only
 Asynchronous command

21.2.14.2 Basic Trigger Search Conditions

SEARch:TRIGger:DATatoclock[:STATe].....	880
SEARch:TRIGger:EDGE[:STATe].....	880
SEARch:TRIGger:GLITch[:STATe].....	880
SEARch:TRIGger:INTerval[:STATe].....	880
SEARch:TRIGger:PATTern[:STATe].....	880
SEARch:TRIGger:RUNT[:STATe].....	880
SEARch:TRIGger:SLEWrate[:STATe].....	880
SEARch:TRIGger:STATe[:STATe].....	880
SEARch:TRIGger:TIMeout[:STATe].....	880
SEARch:TRIGger:WIDTh[:STATe].....	881
SEARch:TRIGger:WINDow[:STATe].....	881
SEARch:TRIGger:LEVel[:VALue].....	881
SEARch:TRIGger:DATatoclock:ACOPY.....	881
SEARch:TRIGger:EDGE:ACOPY.....	881
SEARch:TRIGger:GLITch:ACOPY.....	881
SEARch:TRIGger:INTerval:ACOPY.....	881
SEARch:TRIGger:PATTern:ACOPY.....	881
SEARch:TRIGger:RUNT:ACOPY.....	881
SEARch:TRIGger:SLEWrate:ACOPY.....	881
SEARch:TRIGger:STATe:ACOPY.....	881
SEARch:TRIGger:TIMeout:ACOPY.....	881
SEARch:TRIGger:WIDTh:ACOPY.....	881
SEARch:TRIGger:WINDow:ACOPY.....	881
SEARch:TRIGger:EDGE:BCOPY.....	882

SEARch:TRIGger:DATatoclock[:STATe] <SearchName>,<State>
SEARch:TRIGger:DATatoclock[:STATe]? <SearchName>
SEARch:TRIGger:EDGE[:STATe] <SearchName>,<State>
SEARch:TRIGger:EDGE[:STATe]? <SearchName>
SEARch:TRIGger:GLITch[:STATe] <SearchName>,<State>
SEARch:TRIGger:GLITch[:STATe]? <SearchName>
SEARch:TRIGger:INTerval[:STATe] <SearchName>,<State>
SEARch:TRIGger:INTerval[:STATe]? <SearchName>
SEARch:TRIGger:PATTern[:STATe] <SearchName>,<State>
SEARch:TRIGger:PATTern[:STATe]? <SearchName>
SEARch:TRIGger:RUNT[:STATe] <SearchName>,<State>
SEARch:TRIGger:RUNT[:STATe]? <SearchName>
SEARch:TRIGger:SLEWrate[:STATe] <SearchName>,<State>
SEARch:TRIGger:SLEWrate[:STATe]? <SearchName>
SEARch:TRIGger:STATe[:STATe] <SearchName>,<State>
SEARch:TRIGger:STATe[:STATe]? <SearchName>
SEARch:TRIGger:TIMeout[:STATe] <SearchName>,<State>
SEARch:TRIGger:TIMeout[:STATe]? <SearchName>

SEARch:TRIGger:WIDTh[:STATe] <SearchName>,<State>
SEARch:TRIGger:WIDTh[:STATe]? <SearchName>
SEARch:TRIGger:WINDow[:STATe] <SearchName>,<State>
SEARch:TRIGger:WINDow[:STATe]? <SearchName>

Includes the search conditions for the selected trigger event type in the next search.

Parameters:

<State> ON | OFF
 *RST: OFF

Parameters for setting and query:

<SearchName> Search definition

SEARch:TRIGger:LEVel[:VALue] <SearchName>, <SignalSource>, <Value>
SEARch:TRIGger:LEVel[:VALue]? <SearchName>, <SignalSource>

Sets the voltage level for the trigger level that is used to determine other parameters.

Parameters:

<Value> Voltage value

Parameters for setting and query:

<SearchName> String with the name of the search

<SignalSource> C1W1 | C1W2 | C1W3 | C2W1 | C2W2 | C2W3 | C3W1 | C3W2 |
 C3W3 | C4W1 | C4W2 | C4W3 | M1 | M2 | M3 | M4 | R1 | R2 |
 R3 | R4 | D0 | D1 | D2 | D3 | D4 | D5 | D6 | D7 | D8 | D9 | D10 |
 D11 | D12 | D13 | D14 | D15

Source of the search, see [chapter 21.2.3.2, "Waveform Parameter"](#), on page 666

SEARch:TRIGger:DATatoclock:ACOPy <SearchName>
SEARch:TRIGger:EDGE:ACOPy <SearchName>
SEARch:TRIGger:GLITch:ACOPy <SearchName>
SEARch:TRIGger:INTerval:ACOPy <SearchName>
SEARch:TRIGger:PATTern:ACOPy <SearchName>
SEARch:TRIGger:RUNT:ACOPy <SearchName>
SEARch:TRIGger:SLEWrate:ACOPy <SearchName>
SEARch:TRIGger:STATe:ACOPy <SearchName>
SEARch:TRIGger:TIMEout:ACOPy <SearchName>
SEARch:TRIGger:WIDTh:ACOPy <SearchName>
SEARch:TRIGger:WINDow:ACOPy <SearchName>

Copies the trigger event configuration from Trigger A for the selected channel source to the search condition settings.

See [chapter 4.3.1, "Events and Trigger Types"](#), on page 138.

Setting parameters:

<SearchName> Search definition

Usage: Setting only

SEARch:TRIGger:EDGE:BCOPy <SearchName>

Copies the trigger event configuration from trigger B for the selected channel source to the search condition settings.

Setting parameters:

<SearchName> String with name of the search

Usage: Setting only

21.2.14.3 Edge Search Conditions

Trigger level setting: [SEARch:TRIGger:LEVEl\[:VALue\]](#) on page 881

[SEARch:TRIGger:EDGE:SLOPe](#)..... 882

SEARch:TRIGger:EDGE:SLOPe <SearchName>,<Slope>**SEARch:TRIGger:EDGE:SLOPe?** <SearchName>

Selects the edge type.

Parameters:

<Slope> POSitive | NEGative | EITHer

See [chapter 21.2.3.3, "Slope Parameter"](#), on page 666.

*RST: POSitive

Parameters for setting and query:

<SearchName> Search definition

21.2.14.4 Glitch Search Conditions

Trigger level setting: [SEARch:TRIGger:LEVEl\[:VALue\]](#) on page 881

[SEARch:TRIGger:GLITch:POLarity](#)..... 882

[SEARch:TRIGger:GLITch:RANGe](#)..... 883

[SEARch:TRIGger:GLITch:WIDTh](#)..... 883

SEARch:TRIGger:GLITch:POLarity <SearchName>,<Polarity>**SEARch:TRIGger:GLITch:POLarity?** <SearchName>

Indicates the polarity of a pulse, that is the direction of the first pulse slope.

Parameters:

<Polarity> POSitive | NEGative | EITHer

See [chapter 21.2.3.4, "Polarity Parameter"](#), on page 667.

*RST: POSitive

Parameters for setting and query:

<SearchName> Search definition

SEARCh:TRIGger:GLITCh:RANGe <SearchName>,<RangeMode>

SEARCh:TRIGger:GLITCh:RANGe? <SearchName>

Selects which glitches are identified: shorter or longer than the specified width (see [SEARCh:TRIGger:GLITCh:WIDTh](#) on page 883).

Parameters:

<RangeMode> SHORter | LONGer
 *RST: SHORter

Parameters for setting and query:

<SearchName> Search definition

SEARCh:TRIGger:GLITCh:WIDTh <SearchName>,<Width>

SEARCh:TRIGger:GLITCh:WIDTh? <SearchName>

Sets the length of a glitch. The instrument triggers on pulses shorter or longer than this value (see also [SEARCh:TRIGger:GLITCh:RANGe](#) on page 883).

You need to know the expected pulse widths of the circuit to set the glitch width correctly.

Parameters:

<Width> Range: 100E-12 to 1E-3
 Increment: 100E-6
 *RST: 1E-9
 Default unit: s

Parameters for setting and query:

<SearchName> Search definition

21.2.14.5 Interval Search Conditions

Trigger level setting: [SEARCh:TRIGger:LEVel\[:VALue\]](#) on page 881

SEARCh:TRIGger:INTerval:DELTA	883
SEARCh:TRIGger:INTerval:POLarity	884
SEARCh:TRIGger:INTerval:RANGe	884
SEARCh:TRIGger:INTerval:WIDTh	884

SEARCh:TRIGger:INTerval:DELTA <SearchName>,<WidthDelta>

SEARCh:TRIGger:INTerval:DELTA? <SearchName>

Defines a range around the "Interval width" value (see [SEARCh:TRIGger:INTerval:WIDTh](#) on page 884).

Parameters:

<WidthDelta> Range: 0 to 10
 Increment: 100E-9
 *RST: 0
 Default unit: s

Parameters for setting and query:

<SearchName> Search definition

SEARCH:TRIGger:INTERval:POLarity <SearchName>,<Polarity>

SEARCH:TRIGger:INTERval:POLarity? <SearchName>

Indicates the polarity of a pulse, that is the direction of the first pulse slope.

Parameters:

<Polarity> POSitive | NEGative | EITHer

See [chapter 21.2.3.4, "Polarity Parameter"](#), on page 667.

*RST: POSitive

Parameters for setting and query:

<SearchName> Search definition

SEARCH:TRIGger:INTERval:RANGE <SearchName>,<RangeMode>

SEARCH:TRIGger:INTERval:RANGE? <SearchName>

Selects how the range of an interval is defined based on the interval width and delta (see [SEARCH:TRIGger:INTERval:WIDTH](#) on page 884 and [SEARCH:TRIGger:INTERval:DELTA](#) on page 883).

Parameters:

<RangeMode> WITHin | OUTSide | SHORter | LONGer

WITHin

Triggers on pulse intervals inside a given range. The range is defined by "Interv. width" and "±Delta".

OUTSide

Triggers on intervals outside a given range. The range definition is the same as for "Within" range.

SHORter

Triggers on intervals shorter than the given "Interv. width".

LONGer

Triggers on intervals longer than the given "Interv. width".

*RST: OUTSide

Parameters for setting and query:

<SearchName> Search definition

SEARCH:TRIGger:INTERval:WIDTH <SearchName>,<Width>

SEARCH:TRIGger:INTERval:WIDTH? <SearchName>

Defines the time between two pulses.

Parameters:

<Width> Range: 100E-12 to 864
 Increment: 100E-9
 *RST: 5E-9
 Default unit: s

Parameters for setting and query:

<SearchName> Search definition

21.2.14.6 Runt Search Conditions

SEARch:TRIGger:RUNT:DELTA.....	885
SEARch:TRIGger:RUNT:POLarity.....	885
SEARch:TRIGger:RUNT:RANGe.....	886
SEARch:TRIGger:RUNT:WIDTh.....	886
SEARch:TRIGger:LEVel:RUNT:LOWer.....	887
SEARch:TRIGger:LEVel:RUNT:UPPer.....	887

SEARch:TRIGger:RUNT:DELTA <SearchName>, <WidthDelta>

SEARch:TRIGger:RUNT:DELTA? <SearchName>

Defines a range around the given runt width.

Parameters:

<WidthDelta> Range: 100E-12 to 864
 Increment: 100E-9
 *RST: 100E-12
 Default unit: s

Parameters for setting and query:

<SearchName> Search definition

SEARch:TRIGger:RUNT:POLarity <SearchName>, <Polarity>

SEARch:TRIGger:RUNT:POLarity? <SearchName>

Indicates the polarity of a pulse, that is the direction of the first pulse slope.

Parameters:

<Polarity> POSitive | NEGative | EITHER
 See [chapter 21.2.3.4, "Polarity Parameter"](#), on page 667.
 *RST: POSitive

Parameters for setting and query:

<SearchName> Search definition

SEARCh:TRIGger:RUNT:RANGe <SearchName>,<Mode>

SEARCh:TRIGger:RUNT:RANGe? <SearchName>

Selects how the time limit of the runt pulse is defined based on the runt width and delta (see [SEARCh:TRIGger:RUNT:WIDTh](#) on page 886 and [SEARCh:TRIGger:RUNT:DELTA](#) on page 885).

Parameters:

<Mode> ANY | LONGer | SHORter | WITHin | OUTSide

ANY

Triggers on all runts fulfilling the level condition, without time limitation.

LONGer

Triggers on runts longer than the given "Runt width".

SHORter

Triggers on runts shorter than the given "Runt width".

WITHin

Triggers if the runt length is inside a given time range. The range is defined by "Runt width" and "±Delta".

OUTSide

Triggers if the runt length is outside a given time range. The range definition is the same as for "Within" range.

*RST: ANY

Parameters for setting and query:

<SearchName> Search definition

SEARCh:TRIGger:RUNT:WIDTh <SearchName>,<Width>

SEARCh:TRIGger:RUNT:WIDTh? <SearchName>

For the ranges "Shorter" and "Longer", the runt width defines the maximum and minimum pulse width, respectively.

For the ranges "Within" and "Outside", the runt width defines the center of a range which is defined by "±Delta".

The range is defined using [SEARCh:TRIGger:RUNT:RANGe](#) on page 886.

Parameters:

<Width> Range: 100E-12 to 864
 Increment: 100E-9
 *RST: 5E-9
 Default unit: s

Parameters for setting and query:

<SearchName> Search definition

SEARCh:TRIGger:LEVel:RUNT:LOWer <SearchName>, <SignalSource>, <Value>
SEARCh:TRIGger:LEVel:RUNT:LOWer? <SearchName>, <SignalSource>
SEARCh:TRIGger:LEVel:RUNT:UPPer <SearchName>, <SignalSource>, <Value>
SEARCh:TRIGger:LEVel:RUNT:UPPer? <SearchName>, <SignalSource>

Set the lower and upper voltage threshold, respectively.

Parameters:

<Value> Voltage value

Parameters for setting and query:

<SearchName> String with the name of the search

<SignalSource> C1W1 | C1W2 | C1W3 | C2W1 | C2W2 | C2W3 | C3W1 | C3W2 |
 C3W3 | C4W1 | C4W2 | C4W3 | M1 | M2 | M3 | M4 | R1 | R2 |
 R3 | R4 | D0 | D1 | D2 | D3 | D4 | D5 | D6 | D7 | D8 | D9 | D10 |
 D11 | D12 | D13 | D14 | D15

Source of the search, see [chapter 21.2.3.2, "Waveform Parameter"](#), on page 666

21.2.14.7 Slew Rate Search Conditions

SEARCh:TRIGger:SLEWrate:DELTA	887
SEARCh:TRIGger:SLEWrate:RANGe	887
SEARCh:TRIGger:SLEWrate:SLOPe	888
SEARCh:TRIGger:SLEWrate:TIME	888
SEARCh:TRIGger:LEVel:TRANsition:LOWer	889
SEARCh:TRIGger:LEVel:TRANsition:UPPer	889

SEARCh:TRIGger:SLEWrate:DELTA <SearchName>,<TimeDelta>

SEARCh:TRIGger:SLEWrate:DELTA? <SearchName>

Defines a time range around the given slew rate.

Parameters:

<TimeDelta> Range: 0 to 10
 Increment: 100E-9
 *RST: 0
 Default unit: s

Parameters for setting and query:

<SearchName> String with the name of the search

SEARCh:TRIGger:SLEWrate:RANGe <SearchName>,<RangeMode>

SEARCh:TRIGger:SLEWrate:RANGe? <SearchName>

Selects how the time limit for the slew rate is defined. The time measurement starts when the signal crosses the first trigger level - the upper or lower level depending on the selected slope - and stops when the signal crosses the second level.

Parameters:

<RangeMode> INSRange | OUTRange | LTHan | GTHan

INSRange

Triggers on slew rates inside a given time range. The range is defined by "Slew rate" and "±Delta".

OUTRange

Triggers on slew rates outside a given time range. The range definition is the same as for "Within" range.

LTHan

Triggers on slew rates shorter than the given "Slew rate" limit.

GTHan

Triggers on slew rates longer than the given "Slew rate" limit.

*RST: GTHan

Parameters for setting and query:

<SearchName> String with the name of the search

SEARCh:TRIGger:SLEWrate:SLOPe <SearchName>,<Slope>

SEARCh:TRIGger:SLEWrate:SLOPe? <SearchName>

Selects the edge type.

Parameters:

<Slope> POSitive | NEGative | EITHER

See [chapter 21.2.3.3, "Slope Parameter"](#), on page 666.

*RST: POSitive

Parameters for setting and query:

<SearchName> String with the name of the search

SEARCh:TRIGger:SLEWrate:TIME <SearchName>,<Time>

SEARCh:TRIGger:SLEWrate:TIME? <SearchName>

For the ranges "Within" and "Outside", the slew rate defines the center of a range which is defined by the limits "±Delta".

For the ranges "Shorter" and "Longer", the slew rate defines the maximum and minimum slew rate limits, respectively.

The range is defined using [SEARCh:TRIGger:SLEWrate:RANGe](#).

Parameters:

<Time> Range: 100E-12 to 864

Increment: 100E-9

*RST: 100E-12

Default unit: s

Parameters for setting and query:

<SearchName> String with the name of the search

SEARCh:TRIGger:LEVel:TRANsition:LOWer <SearchName>, <SignalSource>, <Value>

SEARCh:TRIGger:LEVel:TRANsition:LOWer? <SearchName>, <SignalSource>

SEARCh:TRIGger:LEVel:TRANsition:UPPer <SearchName>, <SignalSource>, <Value>

SEARCh:TRIGger:LEVel:TRANsition:UPPer? <SearchName>, <SignalSource>

Set the lower and upper voltage thresholds, respectively. When the signal crosses this level, the slew rate measurement starts or stops depending on the selected slope.

Parameters:

<Value> Voltage value

Parameters for setting and query:

<SearchName> String with the name of the search

<SignalSource> C1W1 | C1W2 | C1W3 | C2W1 | C2W2 | C2W3 | C3W1 | C3W2 | C3W3 | C4W1 | C4W2 | C4W3 | M1 | M2 | M3 | M4 | R1 | R2 | R3 | R4 | D0 | D1 | D2 | D3 | D4 | D5 | D6 | D7 | D8 | D9 | D10 | D11 | D12 | D13 | D14 | D15

Source of the search, see [chapter 21.2.3.2, "Waveform Parameter"](#), on page 666

21.2.14.8 Timeout Search Conditions

Trigger level setting: [SEARCh:TRIGger:LEVel\[:VALue\]](#) on page 881

[SEARCh:TRIGger:TIMEout:RANGE](#)..... 889

[SEARCh:TRIGger:TIMEout:TIME](#)..... 890

SEARCh:TRIGger:TIMEout:RANGE <SearchName>,<TimeoutMode>

SEARCh:TRIGger:TIMEout:RANGE? <SearchName>

Selects the relation of the signal level to the trigger level:

Parameters:

<TimeoutMode> HIGH | LOW | EITHer

HIGH

The signal level stays above the trigger level.

LOW

The signal level stays below the trigger level.

EITHer

The signal level stays above or below the trigger level.

*RST: HIGH

Parameters for setting and query:

<SearchName> Search definition

SEARCh:TRIGger:TIMEout:TIME <SearchName>,<Time>
SEARCh:TRIGger:TIMEout:TIME? <SearchName>

Defines the time limit for the timeout at which the instrument triggers.

Parameters:

<Time> Range: 100E-12 to 864
 Increment: 100E-9
 *RST: 100E-9
 Default unit: s

Parameters for setting and query:

<SearchName> Search definition

21.2.14.9 Width Search Conditions

Trigger level setting: [SEARCh:TRIGger:LEVEl\[:VALue\]](#) on page 881

[SEARCh:TRIGger:WIDTH:DELTA](#).....890
[SEARCh:TRIGger:WIDTH:POLarity](#).....890
[SEARCh:TRIGger:WIDTH:RANGE](#).....891
[SEARCh:TRIGger:WIDTH:WIDTH](#).....891

SEARCh:TRIGger:WIDTH:DELTA <SearchName>,<WidthDelta>
SEARCh:TRIGger:WIDTH:DELTA? <SearchName>

Defines a range around the given width value (see also [SEARCh:TRIGger:WIDTH:WIDTH](#) on page 891).

Parameters:

<WidthDelta> Range: 0 to 432
 Increment: 500E-12
 *RST: 0
 Default unit: s

Parameters for setting and query:

<SearchName> Search definition

Example: See [chapter 21.3.4.1, "Searching for a pulse of specified width"](#),
 on page 1131

SEARCh:TRIGger:WIDTH:POLarity <SearchName>,<Polarity>
SEARCh:TRIGger:WIDTH:POLarity? <SearchName>

Indicates the polarity of a pulse, that is the direction of the first pulse slope.

Parameters:

<Polarity> POSitive | NEGative | EITHer
 See [chapter 21.2.3.4, "Polarity Parameter"](#), on page 667.
 *RST: POSitive

Parameters for setting and query:

<SearchName> Search definition

SEARCh:TRIGger:WIDTh:RANGe <SearchName>,<RangeMode>

SEARCh:TRIGger:WIDTh:RANGe? <SearchName>

Selects how the range of a pulse width is defined in relation to the width and delta (see [SEARCh:TRIGger:WIDTh:WIDTh](#) on page 891 and [SEARCh:TRIGger:WIDTh:DELTA](#) on page 890).

Parameters:

<RangeMode> WITHin | OUTSide | SHORter | LONGer

WITHin

Triggers on pulses inside a given range. The range of the pulse width is defined by "Width" and "±Delta".

OUTSide

Triggers on pulses outside a given range. The range definition is the same as for "Within" range.

SHORter

Triggers on pulses shorter than the given "Width".

LONGer

Triggers on pulses longer than the given "Width".

*RST: WITHin

Parameters for setting and query:

<SearchName> Search definition

Example: See [chapter 21.3.4.1, "Searching for a pulse of specified width"](#), on page 1131

SEARCh:TRIGger:WIDTh:WIDTh <SearchName>,<Width>

SEARCh:TRIGger:WIDTh:WIDTh? <SearchName>

For the ranges "Within" and "Outside", the width defines the center of a range which is defined by the limits "±Delta".

For the ranges "Shorter" and "Longer", the width defines the maximum and minimum pulse width, respectively.

The range is defined using [SEARCh:TRIGger:WIDTh:RANGe](#).

Parameters:

<Width> Range: 100E-12 to 864
 Increment: 100E-9
 *RST: 5E-9
 Default unit: s

Parameters for setting and query:

<SearchName> Search definition

Example: See [chapter 21.3.4.1, "Searching for a pulse of specified width"](#), on page 1131

21.2.14.10 Window Search Conditions

SEARCH:TRIGger:WINDow:DELTA	892
SEARCH:TRIGger:WINDow:RANGe	892
SEARCH:TRIGger:WINDow:TIMerange	893
SEARCH:TRIGger:WINDow:WIDTh	893
SEARCH:TRIGger:LEVel:WINDow:LOWer	894
SEARCH:TRIGger:LEVel:WINDow:UPPer	894

SEARCH:TRIGger:WINDow:DELTA <SearchName>,<WidthDelta>
SEARCH:TRIGger:WINDow:DELTA? <SearchName>

Defines a range around the "Width" value (see [SEARCH:TRIGger:WINDow:WIDTh](#) on page 893).

Parameters:

<WidthDelta> Range: 0 to 432
 Increment: 500E-12
 *RST: 0
 Default unit: s

Parameters for setting and query:

<SearchName> Search definition

SEARCH:TRIGger:WINDow:RANGe <SearchName>,<RangeMode>
SEARCH:TRIGger:WINDow:RANGe? <SearchName>

Selects how the signal run is compared with the window.

Parameters:

<RangeMode> ENTEr | EXIT | WITHin | OUTSide

ENTEr

Triggers when the signal crosses the upper or lower level and thus enters the window made up of these two levels.

EXIT

Triggers when the signal leaves the window.

WITHin

Triggers if the signal stays between the upper and lower level for a specified time. The time is defined in various ways by the [SEARCH:TRIGger:WINDow:TIMerange](#) command.

OUTSide

Triggers if the signal stays above the upper level or below the lower level for a specified time. The time is also defined by the [SEARCH:TRIGger:WINDow:TIMerange](#) command.

*RST: ENTEr

Parameters for setting and query:

<SearchName> Search definition

SEARCh:TRIGger:WINDow:TIMerange <SearchName>,<TimeRangeMode>

SEARCh:TRIGger:WINDow:TIMerange? <SearchName>

Selects how the time limit of the window is defined. Time conditioning is available for the vertical conditions "WITHin" and "OUTSide" (see [SEARCh:TRIGger:WINDow:RANGe](#) on page 892).

Parameters:

<TimeRangeMode> WITHin | OUTSide | SHORter | LONGer

WITHin

Triggers if the signal stays inside or outside the vertical window limits at least for the time *Width - Delta* and for *Width + Delta* at the most.

OUTSide

"Outside" is the opposite definition of "Within". The instrument triggers if the signal stays inside or outside the vertical window limits for a time shorter than *Width - Delta* or longer than *Width + Delta*.

SHORter

Triggers if the signal crosses vertical limits before the specified "Width" time is reached.

LONGer

Triggers if the signal crosses vertical limits before the specified "Width" time is reached.

*RST: WITHin

Parameters for setting and query:

<SearchName> Search definition

SEARCh:TRIGger:WINDow:WIDTh <SearchName>,<Width>

SEARCh:TRIGger:WINDow:WIDTh? <SearchName>

For the ranges "Within" and "Outside", the width defines the center of a time range which is defined by the limits " $\pm\Delta$ ".

For the ranges "Shorter" and "Longer", it defines the maximum and minimum time lapse, respectively.

The range is defined using [SEARCh:TRIGger:WINDow:RANGe](#).

Parameters:

<Width> Range: 100E-12 to 864
 Increment: 100E-9
 *RST: 5E-9
 Default unit: s

Parameters for setting and query:**<SearchName>** Search definition**SEARch:TRIGger:LEVel:WINDow:LOWer** <SearchName>, <SignalSource>, <Value>**SEARch:TRIGger:LEVel:WINDow:LOWer?** <SearchName>, <SignalSource>**SEARch:TRIGger:LEVel:WINDow:UPPer** <SearchName>, <SignalSource>, <Value>**SEARch:TRIGger:LEVel:WINDow:UPPer?** <SearchName>, <SignalSource>

Set the lower and upper voltage limits for the window.

Parameters:**<Value>** Voltage value**Parameters for setting and query:****<SearchName>** String with the name of the search**<SignalSource>** C1W1 | C1W2 | C1W3 | C2W1 | C2W2 | C2W3 | C3W1 | C3W2 | C3W3 | C4W1 | C4W2 | C4W3 | M1 | M2 | M3 | M4 | R1 | R2 | R3 | R4 | D0 | D1 | D2 | D3 | D4 | D5 | D6 | D7 | D8 | D9 | D10 | D11 | D12 | D13 | D14 | D15Source of the search, see [chapter 21.2.3.2, "Waveform Parameter"](#), on page 666**21.2.14.11 Data2Clock Search Conditions**Data level setting: [SEARch:TRIGger:LEVel\[:VALue\]](#) on page 881[SEARch:TRIGger:DATatoclock:CEdGe](#)..... 894[SEARch:TRIGger:DATatoclock:CLEVel](#).....895[SEARch:TRIGger:DATatoclock:CSource](#)..... 895[SEARch:TRIGger:DATatoclock:HTIME](#).....895[SEARch:TRIGger:DATatoclock:STIME](#)..... 896**SEARch:TRIGger:DATatoclock:CEdGe** <SearchName>,<ClockEdge>**SEARch:TRIGger:DATatoclock:CEdGe?** <SearchName>

Sets the edge of the clock signal to define the time reference point for the setup and hold time.

Parameters:**<ClockEdge>** POSitive | NEGative | EITHERSee [chapter 21.2.3.3, "Slope Parameter"](#), on page 666.***RST:** POSitive**Parameters for setting and query:****<SearchName>** Search definition

SEARCh:TRIGger:DATatoclock:CLeVel <SearchName>,<ClockLevel>
SEARCh:TRIGger:DATatoclock:CLeVel? <SearchName>

Sets the voltage level for the clock signal. Both this command and [SEARCh:TRIGger:DATatoclock:CEdGe](#) define the starting point for calculation of the setup and hold time.

Parameters:

<ClockLevel> Range: -10 to 10
 Increment: 1E-3
 *RST: 0
 Default unit: V

Parameters for setting and query:

<SearchName> Search definition

SEARCh:TRIGger:DATatoclock:CSourCe <SearchName>,<ClockSource>
SEARCh:TRIGger:DATatoclock:CSourCe? <SearchName>

Selects the waveform used for the clock signal.

Parameters:

<ClockSource> C1W1 | C1W2 | C1W3 | C2W1 | C2W2 | C2W3 | C3W1 | C3W2 |
 C3W3 | C4W1 | C4W2 | C4W3 | M1 | M2 | M3 | M4 | R1 | R2 |
 R3 | R4
 Source of the clock signal, see [chapter 21.2.3.2, "Waveform Parameter"](#), on page 666
 *RST: C1W1

Parameters for setting and query:

<SearchName> Search definition name

SEARCh:TRIGger:DATatoclock:HTIME <SearchName>,<HoldTime>
SEARCh:TRIGger:DATatoclock:HTIME? <SearchName>

Sets the minimum time **after** the clock edge while the data signal must stay steady above or below the data level.

The hold time can be negative. In this case, the setup time is always positive. The setup/hold interval starts before the clock edge (setup time) and ends before the clock edge (hold time). If you change the negative hold time, the setup time is adjusted by the instrument.

Parameters:

<HoldTime> Range: -99.999E-9 to 0.1
 Increment: 1E-9
 *RST: 0
 Default unit: s

Parameters for setting and query:

<SearchName> Search definition

SEARCh:TRIGger:DATatoclock:STIME <SearchName>,<SetupTime>
SEARCh:TRIGger:DATatoclock:STIME? <SearchName>

Sets the minimum time **before** the clock edge while the data signal must stay steady above or below the data level.

The setup time can be negative. In this case, the hold time is always positive. The setup/hold interval starts after the clock edge (setup time) and ends after the clock edge (hold time). If you change the negative setup time, the hold time is adjusted by the instrument.

Parameters:

<SetupTime> Range: -99.999E-9 to 0.1
 Increment: 1E-9
 *RST: 0
 Default unit: s

Parameters for setting and query:

<SearchName> Search definition

21.2.14.12 Pattern Search Conditions

SEARCh:TRIGger:PATTern:A[:ENABLE]	896
SEARCh:TRIGger:PATTern:B[:ENABLE]	896
SEARCh:TRIGger:PATTern:C[:ENABLE]	896
SEARCh:TRIGger:PATTern:D[:ENABLE]	896
SEARCh:TRIGger:PATTern:A:LOGic	897
SEARCh:TRIGger:PATTern:B:LOGic	897
SEARCh:TRIGger:PATTern:C:LOGic	897
SEARCh:TRIGger:PATTern:D:LOGic	897
SEARCh:TRIGger:PATTern:AB:LOGic	898
SEARCh:TRIGger:PATTern:CD:LOGic	898
SEARCh:TRIGger:PATTern:ABCD:LOGic	898
SEARCh:TRIGger:PATTern:MODE	898
SEARCh:TRIGger:PATTern:TIMEout:MODE	899
SEARCh:TRIGger:PATTern:TIMEout[:TIME]	899
SEARCh:TRIGger:PATTern:WIDTh:RANGe	899
SEARCh:TRIGger:PATTern:WIDTh[:WIDTh]	900
SEARCh:TRIGger:PATTern:WIDTh:DELTA	900

SEARCh:TRIGger:PATTern:A[:ENABLE] <Searchname>, <State>
SEARCh:TRIGger:PATTern:A[:ENABLE]? <Searchname>
SEARCh:TRIGger:PATTern:B[:ENABLE] <Searchname>, <State>
SEARCh:TRIGger:PATTern:B[:ENABLE]? <Searchname>
SEARCh:TRIGger:PATTern:C[:ENABLE] <Searchname>, <State>
SEARCh:TRIGger:PATTern:C[:ENABLE]? <Searchname>
SEARCh:TRIGger:PATTern:D[:ENABLE] <Searchname>, <State>
SEARCh:TRIGger:PATTern:D[:ENABLE]? <Searchname>

Enables the channel to be considered in the pattern search. The trigger source channel is selected by default.

- A[:ENABle]: CH1
- B[:ENABle]: CH2
- C[:ENABle]: CH3
- D[:ENABle]: CH4

Digital channels are not available.

Parameters:

<State> ON | OFF

Parameters for setting and query:

<Searchname> String with name of the search

Firmware/Software: FW 1.40

SEARCh:TRIGger:PATtern:A:LOGic <Searchname>, <Operator>

SEARCh:TRIGger:PATtern:A:LOGic? <Searchname>

SEARCh:TRIGger:PATtern:B:LOGic <Searchname>, <Operator>

SEARCh:TRIGger:PATtern:B:LOGic? <Searchname>

SEARCh:TRIGger:PATtern:C:LOGic <Searchname>, <Operator>

SEARCh:TRIGger:PATtern:C:LOGic? <Searchname>

SEARCh:TRIGger:PATtern:D:LOGic <Searchname>, <Operator>

SEARCh:TRIGger:PATtern:D:LOGic? <Searchname>

Defines the logic for the indicated channel:

- A: CH1
- B: CH2
- C: CH3
- D: CH4

Parameters:

<Operator> DIRect | NOT

DIRect

Input value remains unchanged

NOT

Input value is inverted

Parameters for setting and query:

<Searchname> String with the name of the search

Firmware/Software: FW 1.40

SEARCh:TRIGger:PATtern:AB:LOGic <Searchname>, <Operator>
SEARCh:TRIGger:PATtern:AB:LOGic? <Searchname>
SEARCh:TRIGger:PATtern:CD:LOGic <Searchname>, <Operator>
SEARCh:TRIGger:PATtern:CD:LOGic? <Searchname>
SEARCh:TRIGger:PATtern:ABCD:LOGic <Searchname>, <Operator>
SEARCh:TRIGger:PATtern:ABCD:LOGic? <Searchname>

Defines the logical combination of the indicated channels after evaluating the previous logical operations:

- AB: CH1 and CH2
- CD: CH3 and CH4
- ABCD: result of AB and CD

Parameters:

<Operator> AND | NAND | OR | NOR
 AND: logical AND, conjunctive combination
 NAND: logical NOT AND
 OR: logical OR, disjunctive combination
 NOR: logical NOT OR

Parameters for setting and query:

<Searchname> String with the name of the search

Firmware/Software: FW 1.40

SEARCh:TRIGger:PATtern:MODE <SearchName>, <Mode>
SEARCh:TRIGger:PATtern:MODE? <SearchName>

Adds additional time limitation to the pattern definition.

Parameters:

<Mode> OFF | TIMEout | WIDTHh
 OFF
 No time limitation. The event is found if the pattern condition is fulfilled.
 TIMEout
 Defines how long the result of the pattern condition stays high or low. The duration of the timeout is defined using [SEARCh:TRIGger:PATtern:TIMEout\[:TIME\]](#) The result state is defined using [SEARCh:TRIGger:PATtern:TIMEout:MODE](#).
 WIDTHh
 Defines a time range for keeping up the true result of the pattern condition. The range is defined using [SEARCh:TRIGger:PATtern:WIDTHh:RANGe](#).
 *RST: OFF

Parameters for setting and query:

<SearchName> String with the name of the search

Firmware/Software: FW 1.40

SEARCh:TRIGger:PATtern:TIMEout:MODE <SearchName>, <TimeoutMode>
SEARCh:TRIGger:PATtern:TIMEout:MODE? <SearchName>

Defines the condition for the timeout.

Parameters:

<TimeoutMode> HIGH | LOW | EITHER

EITHER

High or low, the pattern remains unchanged for the given time.

*RST: HIGH

Parameters for setting and query:

<SearchName> String with the name of the search

Firmware/Software: FW 1.40

SEARCh:TRIGger:PATtern:TIMEout[:TIME] <SearchName>, <Time>
SEARCh:TRIGger:PATtern:TIMEout[:TIME]? <SearchName>

Defines how long the result of the pattern condition must keep the given state.

Parameters:

<Time> Range: 100E-12 to 864

Increment: 100E-9

*RST: 100E-9

Default unit: s

Parameters for setting and query:

<SearchName> String with the name of the search

Firmware/Software: FW 1.40

SEARCh:TRIGger:PATtern:WIDTh:RANGe <SearchName>, <WidthRangeMode>
SEARCh:TRIGger:PATtern:WIDTh:RANGe? <SearchName>

Defines the time range of a pulse width for keeping up the true result of the pattern condition. The width and delta are specified using [SEARCh:TRIGger:PATtern:WIDTh\[:WIDTh\]](#) and [SEARCh:TRIGger:PATtern:WIDTh:DELTA](#).

Parameters:

<WidthRangeMode> WITHin | OUTSide | SHORter | LONGer

WITHin | OUTSide

Triggers on pulses inside or outside a given range. The range is defined by the width \pm delta.

SHORter | LONGer

Triggers on pulses shorter or longer than the given width.

*RST: WITHin

Parameters for setting and query:

<SearchName> String with the name of the search

Firmware/Software: FW 1.40

SEARch:TRIGger:PATtern:WIDTh[:WIDTh] <SearchName>, <Width>
SEARch:TRIGger:PATtern:WIDTh[:WIDTh]? <SearchName>

For the ranges WITHin and OUTSide, the width defines the center of a range that is defined by the limits $\pm\delta$.

For the ranges SHORter and LONGer, the width defines the maximum and minimum pulse width, respectively.

To set the range mode, use `SEARch:TRIGger:PATtern:WIDTh:RANGe`. To set the delta value, use `SEARch:TRIGger:PATtern:WIDTh:DELTA`.

Parameters:

<Width> Range: 100E-12 to 864
 Increment: 100E-9
 *RST: 5E-9
 Default unit: s

Parameters for setting and query:

<SearchName> String with the name of the search

Firmware/Software: FW 1.40

SEARch:TRIGger:PATtern:WIDTh:DELTA <SearchName>,<WidthDelta>
SEARch:TRIGger:PATtern:WIDTh:DELTA? <SearchName>

Defines a range around the width value specified using `SEARch:TRIGger:PATtern:WIDTh[:WIDTh]`.

Parameters:

<WidthDelta> Range: 0 to 432
 Increment: 500E-12
 *RST: 0
 Default unit: s

Parameters for setting and query:

<SearchName> String with the name of the search

Firmware/Software: FW 1.40

21.2.14.13 State Search Conditions

<code>SEARch:TRIGger:STATe:CSource</code>	901
<code>SEARch:TRIGger:STATe:CEdGe</code>	901
<code>SEARch:TRIGger:STATe:CLEVel</code>	901
<code>SEARch:TRIGger:STATe:A[:ENABle]</code>	902
<code>SEARch:TRIGger:STATe:B[:ENABle]</code>	902
<code>SEARch:TRIGger:STATe:C[:ENABle]</code>	902
<code>SEARch:TRIGger:STATe:D[:ENABle]</code>	902
<code>SEARch:TRIGger:STATe:A:LOGic</code>	902
<code>SEARch:TRIGger:STATe:B:LOGic</code>	902
<code>SEARch:TRIGger:STATe:C:LOGic</code>	902
<code>SEARch:TRIGger:STATe:D:LOGic</code>	902

SEARCh:TRIGger:STATe:AB:LOGic	903
SEARCh:TRIGger:STATe:CD:LOGic	903
SEARCh:TRIGger:STATe:ABCD:LOGic	903

SEARCh:TRIGger:STATe:CSource <SearchName>,<ClockSource>
SEARCh:TRIGger:STATe:CSource? <SearchName>

Sets the source of the clock signal.

Parameters:

<ClockSource> C1W1 | C2W1 | C3W1 | C4W1
 *RST: NONE

Parameters for setting and query:

<SearchName> String with the name of the search

Firmware/Software: FW 1.40

SEARCh:TRIGger:STATe:CEdGe <SearchName>,<ClockEdge>
SEARCh:TRIGger:STATe:CEdGe? <SearchName>

Sets the trigger edge of the clock signal.

Parameters:

<ClockEdge> POSitive | NEGative | EITHER
 *RST: POSitive

Parameters for setting and query:

<SearchName> String with the name of the search

Firmware/Software: FW 1.40

SEARCh:TRIGger:STATe:CLEVel <SearchName>,<ClockLevel>
SEARCh:TRIGger:STATe:CLEVel? <SearchName>

Sets the trigger level of the clock signal.

The command has the same effect as with [SEARCh:TRIGger:LEVel\[:VALue\]](#).

Parameters:

<ClockLevel> Range: -10 to 10
 Increment: 1E-3
 *RST: 0
 Default unit: V

Parameters for setting and query:

<SearchName> String with the name of the search

Firmware/Software: FW 1.40

```

SEARCh:TRIGger:STATe:A[:ENABle] <Searchname>, <State>
SEARCh:TRIGger:STATe:A[:ENABle]? <Searchname>
SEARCh:TRIGger:STATe:B[:ENABle] <Searchname>, <State>
SEARCh:TRIGger:STATe:B[:ENABle]? <Searchname>
SEARCh:TRIGger:STATe:C[:ENABle] <Searchname>, <State>
SEARCh:TRIGger:STATe:C[:ENABle]? <Searchname>
SEARCh:TRIGger:STATe:D[:ENABle] <Searchname>, <State>
SEARCh:TRIGger:STATe:D[:ENABle]? <Searchname>

```

Enables the channel to be considered in the state search. You can enable all channel signals except for the trigger source.

- A[:ENABle]: CH1
- B[:ENABle]: CH2
- C[:ENABle]: CH3
- D[:ENABle]: CH4

Digital channels are not available.

Parameters:

<State> ON | OFF

Parameters for setting and query:

<Searchname> String with the name of the search

Firmware/Software: FW 1.40

```

SEARCh:TRIGger:STATe:A:LOGic <Searchname>, <Operator>
SEARCh:TRIGger:STATe:A:LOGic? <Searchname>
SEARCh:TRIGger:STATe:B:LOGic <Searchname>, <Operator>
SEARCh:TRIGger:STATe:B:LOGic? <Searchname>
SEARCh:TRIGger:STATe:C:LOGic <Searchname>, <Operator>
SEARCh:TRIGger:STATe:C:LOGic? <Searchname>
SEARCh:TRIGger:STATe:D:LOGic <Searchname>, <Operator>
SEARCh:TRIGger:STATe:D:LOGic? <Searchname>

```

Defines the logic for the indicated channel:

- A: CH1
- B: CH2
- C: CH3
- D: CH4

Parameters:

<Operator> DIReCt | NOT

DIReCt

Input value remains unchanged

NOT

Input value is inverted

Parameters for setting and query:

<Searchname> String with the name of the search

Firmware/Software: FW 1.40

SEARCH:TRIGger:STATE:AB:LOGic <Searchname>, <Operator>

SEARCH:TRIGger:STATE:AB:LOGic? <Searchname>

SEARCH:TRIGger:STATE:CD:LOGic <Searchname>, <Operator>

SEARCH:TRIGger:STATE:CD:LOGic? <Searchname>

SEARCH:TRIGger:STATE:ABCD:LOGic <Searchname>, <Operator>

SEARCH:TRIGger:STATE:ABCD:LOGic? <Searchname>

Defines the logical combination of the indicated channels after evaluating the previous logical operations:

- AB: CH1 and CH2
- CD: CH3 and CH4
- ABCD: result of AB and CD

Parameters:

<Operator> AND | NAND | OR | NOR
 AND: logical AND, conjunctive combination
 NAND: logical NOT AND
 OR: logical OR, disjunctive combination
 NOR: logical NOT OR

Parameters for setting and query:

<Searchname> String with the name of the search

Firmware/Software: FW 1.40

21.2.14.14 Search Scope Settings

SEARCH:GATE[:STATE]	903
SEARCH:GATE:MODE	904
SEARCH:GATE:SHOW	904
SEARCH:GATE:ABSolute:START	904
SEARCH:GATE:ABSolute:STOP	904
SEARCH:GATE:RELative:START	905
SEARCH:GATE:RELative:STOP	905
SEARCH:GATE:ZCOupling	905
SEARCH:GATE:ZDIagram	905

SEARCH:GATE[:STATE] <SearchName>, <State>

SEARCH:GATE[:STATE]? <SearchName>

Performs the search only on the defined gate area of the source waveform.

Parameters:

<State> ON | OFF
 *RST: OFF

Parameters for setting and query:

<SearchName> Search definition

SEARCH:GATE:MODE <SearchName>,<Mode>
SEARCH:GATE:MODE? <SearchName>

Defines whether the gate settings are configured using absolute or relative values.

Parameters:

<Mode> ABS | REL
 *RST: ABS

Parameters for setting and query:

<SearchName> Search definition

SEARCH:GATE:SHOW <SearchName>,<DisplayState>
SEARCH:GATE:SHOW? <SearchName>

If enabled, the gate area is indicated in the source diagram.

Parameters:

<DisplayState> ON | OFF
 *RST: OFF

Parameters for setting and query:

<SearchName> Search definition

SEARCH:GATE:ABSolute:START <SearchName>,<Start>
SEARCH:GATE:ABSolute:START? <SearchName>

Defines the starting value for the gate.

Parameters:

<Start> Range: -100E+24 to 100E+24
 Increment: 0.01
 *RST: 0.01

Parameters for setting and query:

<SearchName> Search definition

SEARCH:GATE:ABSolute:STOP <SearchName>,<Stop>
SEARCH:GATE:ABSolute:STOP? <SearchName>

Defines the end value for the gate.

Parameters:

<Stop> Range: -100E+24 to 100E+24
 Increment: 0.01
 *RST: 0.01

Parameters for setting and query:

<SearchName> Search definition

SEARCh:GATE:RELative:START <SearchName>,<RelativeStart>
SEARCh:GATE:RELative:START? <SearchName>

Defines the starting value for the gate.

Parameters:

<RelativeStart> Range: -100E+24 to 100E+24
 Increment: 0.1
 *RST: 0
 Default unit: %

Parameters for setting and query:

<SearchName> Search definition

SEARCh:GATE:RELative:STOP <SearchName>,<RelativeStop>
SEARCh:GATE:RELative:STOP? <SearchName>

Defines the end value for the gate.

Parameters:

<RelativeStop> Range: -100E+24 to 100E+24
 Increment: 0.1
 *RST: 100
 Default unit: %

Parameters for setting and query:

<SearchName> Search definition

SEARCh:GATE:ZCOupling <SearchName>,<ZoomCoupling>
SEARCh:GATE:ZCOupling? <SearchName>

If enabled, the gate area is set to the limits of a zoom area.

The zoom diagramm is selected using [SEARCh:GATE:ZDIagram](#).

Parameters:

<ZoomCoupling> ON | OFF
 *RST: OFF

Parameters for setting and query:

<SearchName> String with the name of the search

SEARCh:GATE:ZDIagram <SearchName>,<DiagramName>,<ZoomName>
SEARCh:GATE:ZDIagram? <SearchName>

Selects the zoom to which the gate area is set if [SEARCh:GATE:ZCOupling](#) is set to "ON".

Parameters:

<DiagramName> String with the name of the diagram on which the zoom area is based.

<ZoomName> String with the name of the zoom.

Parameters for setting and query:

<SearchName> String with the name of the search

Example:

```
SEARCh:GATE:ZCOupling 'Search1',ON
SEARCh:GATE:ZDIagram 'Search1','Diagram1',
'Zoom2'
SEARCh:GATE:ZDIagram? 'Search1'
<-- Diagram1;Zoom2
```

Enables the zoom coupling to define the gate, and selects Zoom2 as gate area. Zoom2 is based on Diagram1.

21.2.14.15 Noise Rejection

SEARCh:TRIGger:LEVel:NOISe:ABSolute.....	906
SEARCh:TRIGger:LEVel:NOISe:MODE.....	906
SEARCh:TRIGger:LEVel:NOISe:RELative.....	907
SEARCh:TRIGger:LEVel:NOISe[:STATe].....	907

SEARCh:TRIGger:LEVel:NOISe:ABSolute <SearchName>, <SignalSource>, <Value>

Defines the trigger hysteresis, a range in absolute values around the trigger level. If the signal jitters inside this range and crosses the trigger level, no trigger event is detected.

Parameters:

<Value> Hysteresis value

Setting parameters:

<SearchName> String with the name of the search

<SignalSource> C1W1 | C1W2 | C1W3 | C2W1 | C2W2 | C2W3 | C3W1 | C3W2 | C3W3 | C4W1 | C4W2 | C4W3 | M1 | M2 | M3 | M4 | R1 | R2 | R3 | R4 | D0 | D1 | D2 | D3 | D4 | D5 | D6 | D7 | D8 | D9 | D10 | D11 | D12 | D13 | D14 | D15

Source of the search, see [chapter 21.2.3.2, "Waveform Parameter"](#), on page 666

SEARCh:TRIGger:LEVel:NOISe:MODE <SearchName>, <SignalSource>, <Mode>

SEARCh:TRIGger:LEVel:NOISe:MODE? <SearchName>, <SignalSource>

Defines whether absolute values or relative values to the vertical scaling are used as a hysteresis for noise rejection.

Parameters:

<Mode> ABS | REL

Parameters for setting and query:

<SearchName> String with the name of the search

<SignalSource> C1W1 | C1W2 | C1W3 | C2W1 | C2W2 | C2W3 | C3W1 | C3W2 | C3W3 | C4W1 | C4W2 | C4W3 | M1 | M2 | M3 | M4 | R1 | R2 | R3 | R4 | D0 | D1 | D2 | D3 | D4 | D5 | D6 | D7 | D8 | D9 | D10 | D11 | D12 | D13 | D14 | D15

Source of the trigger waveform, see [chapter 21.2.3.2, "Waveform Parameter"](#), on page 666

SEARch:TRIGger:LEVel:NOISe:RELative <SearchName>, <SignalSource>, <Value>

Defines a range around the trigger level in relative values. If the signal jitters inside this range and crosses the trigger level, no trigger event is detected.

Parameters:

<Value> Hysteresis value in %

Setting parameters:

<SearchName> String with the name of the search

<SignalSource> C1W1 | C1W2 | C1W3 | C2W1 | C2W2 | C2W3 | C3W1 | C3W2 | C3W3 | C4W1 | C4W2 | C4W3 | M1 | M2 | M3 | M4 | R1 | R2 | R3 | R4 | D0 | D1 | D2 | D3 | D4 | D5 | D6 | D7 | D8 | D9 | D10 | D11 | D12 | D13 | D14 | D15

Source of the search, see [chapter 21.2.3.2, "Waveform Parameter"](#), on page 666

SEARch:TRIGger:LEVel:NOISe[:STATe] <SearchName>, <SignalSource>, <State>
SEARch:TRIGger:LEVel:NOISe[:STATe]? <SearchName>, <SignalSource>

If enabled, the noise reject settings for the waveform are considered for the search.

Parameters:

<State> ON | OFF

Parameters for setting and query:

<SearchName> String with the name of the search

<SignalSource> C1W1 | C1W2 | C1W3 | C2W1 | C2W2 | C2W3 | C3W1 | C3W2 | C3W3 | C4W1 | C4W2 | C4W3 | M1 | M2 | M3 | M4 | R1 | R2 | R3 | R4 | D0 | D1 | D2 | D3 | D4 | D5 | D6 | D7 | D8 | D9 | D10 | D11 | D12 | D13 | D14 | D15

Source of the search, see [chapter 21.2.3.2, "Waveform Parameter"](#), on page 666

21.2.14.16 Search Results

SEARch:RESDiagram:HORIZ:ABSolute:POSition.....	908
SEARch:RESDiagram:HORIZ:ABSolute:SPAN.....	908
SEARch:RESDiagram:HORIZ:MODE.....	908
SEARch:RESDiagram:HORIZ:RELative:POSition.....	909
SEARch:RESDiagram:HORIZ:RELative:SPAN.....	909
SEARch:RESDiagram:SHOW.....	909

SEARCH:RESDiagram:VERT:ABSolute:POSition.....	909
SEARCH:RESDiagram:VERT:ABSolute:SPAN.....	910
SEARCH:RESDiagram:VERT:MODE.....	910
SEARCH:RESDiagram:VERT:RELative:POSition.....	910
SEARCH:RESDiagram:VERT:RELative:SPAN.....	910
SEARCH:RESult:LIMit.....	911
SEARCH:RESult:SHOW.....	911
SEARCH:RESult:SORT:ASCending.....	911
SEARCH:RESult:SORT[:MODE].....	912
SEARCH:RESult[:ALL]?.....	912

SEARCH:RESDiagram:HORIZ:ABSolute:POSition <SearchName>,<Position>
SEARCH:RESDiagram:HORIZ:ABSolute:POSition? <SearchName>

Defines the x-value of the centerpoint of the zoom area.

Parameters:

<Position> Range: -100E+24 to 100E+24
 Increment: 0.01
 *RST: 0.01

Parameters for setting and query:

<SearchName> Search definition

SEARCH:RESDiagram:HORIZ:ABSolute:SPAN <SearchName>,
SEARCH:RESDiagram:HORIZ:ABSolute:SPAN? <SearchName>

Defines the width of the zoom area.

Parameters:

 Range: 0 to 100E+24
 Increment: 0.01
 *RST: 0.01

Parameters for setting and query:

<SearchName> Search definition

SEARCH:RESDiagram:HORIZ:MODE <SearchName>,<Mode>
SEARCH:RESDiagram:HORIZ:MODE? <SearchName>

Defines whether absolute or relative values are used to specify the x-axis values.

Parameters:

<Mode> ABS | REL
 *RST: ABS

Parameters for setting and query:

<SearchName> Search definition

SEARCh:RESDiagram:HORIZ:RELative:POSition <SearchName>,<RelPosi>
SEARCh:RESDiagram:HORIZ:RELative:POSition? <SearchName>

Defines the x-value of the centerpoint of the zoom area.

Parameters:

<RelPosi> Range: -100E+24 to 100E+24
 Increment: 0.1
 *RST: 100
 Default unit: %

Parameters for setting and query:

<SearchName> Search definition

SEARCh:RESDiagram:HORIZ:RELative:SPAN <SearchName>,<RelativeSpan>
SEARCh:RESDiagram:HORIZ:RELative:SPAN? <SearchName>

Defines the width of the zoom area.

Parameters:

<RelativeSpan> Range: -100E+24 to 100E+24
 Increment: 0.1
 *RST: 0
 Default unit: %

Parameters for setting and query:

<SearchName> Search definition

SEARCh:RESDiagram:SHOW <SearchName>,<ShowSearchWind>
SEARCh:RESDiagram:SHOW? <SearchName>

If enabled, a zoom window is displayed for the currently selected search result. The zoom area is indicated in the diagram that displays the source waveform of the search.

Parameters:

<ShowSearchWind> ON | OFF
 *RST: OFF

Parameters for setting and query:

<SearchName> Search definition

SEARCh:RESDiagram:VERT:ABSolute:POSition <SearchName>,<Position>
SEARCh:RESDiagram:VERT:ABSolute:POSition? <SearchName>

Defines the y-value of the centerpoint of the zoom area.

Parameters:

<Position> Range: -100E+24 to 100E+24
 Increment: 0.01
 *RST: 0.01

Parameters for setting and query:

<SearchName> Search definition

SEARCH:RESDiagram:VERT:ABSolute:SPAN <SearchName>,

SEARCH:RESDiagram:VERT:ABSolute:SPAN? <SearchName>

Defines the height of the zoom area.

Parameters:

 Range: 0 to 100E+24
 Increment: 0.01
 *RST: 0.01

Parameters for setting and query:

<SearchName> Search definition

SEARCH:RESDiagram:VERT:MODE <SearchName>,<Mode>

SEARCH:RESDiagram:VERT:MODE? <SearchName>

Defines whether absolute or relative values are used to specify the y-axis values.

Parameters:

<Mode> ABS | REL
 *RST: ABS

Parameters for setting and query:

<SearchName> Search definition

SEARCH:RESDiagram:VERT:RELative:POSition <SearchName>,<RelPosi>

SEARCH:RESDiagram:VERT:RELative:POSition? <SearchName>

Defines the y-value of the centerpoint of the zoom area.

Parameters:

<RelPosi> Range: -100E+24 to 100E+24
 Increment: 0.1
 *RST: 100
 Default unit: %

Parameters for setting and query:

<SearchName> Search definition

SEARCH:RESDiagram:VERT:RELative:SPAN <SearchName>,<RelativeSpan>

SEARCH:RESDiagram:VERT:RELative:SPAN? <SearchName>

Defines the height of the zoom area.

Parameters:

<RelativeSpan> Range: -100E+24 to 100E+24
 Increment: 0.1
 *RST: 0
 Default unit: %

Parameters for setting and query:

<SearchName> Search definition

SEARCH:RESult:LIMit <SearchName>,<ResultListLimit>

SEARCH:RESult:LIMit? <SearchName>

Defines the maximum number of entries in the search result table.

Parameters:

<ResultListLimit> Range: 1 to 100
 Increment: 1
 *RST: 20

Parameters for setting and query:

<SearchName> Search definition

Example: See [chapter 21.3.4.1, "Searching for a pulse of specified width"](#),
 on page 1131

SEARCH:RESult:SHOW <SearchName>,<ShowResultTable>

SEARCH:RESult:SHOW? <SearchName>

Displays or hides the search result table.

Parameters:

<ShowResultTable> ON | OFF
 *RST: OFF

Parameters for setting and query:

<SearchName> Search definition

SEARCH:RESult:SORT:ASCending <SearchName>,<SortAscending>

SEARCH:RESult:SORT:ASCending? <SearchName>

If enabled, the results are listed in ascending order, i.e. the smallest value at the top.

Parameters:

<SortAscending> ON | OFF
 *RST: OFF

Parameters for setting and query:

<SearchName> Search definition

SEARch:RESult:SORt[:MODE] <SearchName>,<SortMode>
SEARch:RESult:SORt[:MODE]? <SearchName>

Sorts the search result table by x-value position or value of the result.

Parameters:

<SortMode> POSition | VALue

POSition

Sorts the search result table by the x-value position.

VALue

Sorts the search result table by the value of the result.

*RST: POSition

Parameters for setting and query:

<SearchName> Search definition

SEARch:RESult[:ALL]? <SearchName>

Returns all search results.

Query parameters:

<SearchName> Search definition

Return values:

<Data> List of search results, separated by commas. For each result, six values are returned:

1. Acquisition index, currently always 0.
2. X-position of the search result
3. Y-position of the search result, currently not relevant
4. Type of the search result (Edge, Glitch, ...)
5. Slope or polarity of the search result
6. For runt, glitch, width, and window searches, the value contains the width. For timeout and interval searches, it contains the timeout. For transition searches, it contains the slew rate. For all other searches, the value is not relevant. If a value is not relevant, 9.91E+37 is returned.

Example:

```
SEAR:RES? 'Search1'
0,1.5375e-007,-84,Edge,Positive,9.91E+37,
0,5.3e-008,-84,Edge,Positive,9.91E+37
```

The query returns two search results for edge search on rising edges at X-position 153,75 ns and 53 ns.

Usage:

Query only

21.2.15 Data Management

• Instrument Settings.....	913
• Waveform Data Export.....	920
• Waveform Histogram Export.....	926
• Long Term Measurement Results and Measurement Histogram Export.....	928
• Screenshots.....	929

21.2.15.1 Instrument Settings

The Mass MEMemory subsystem provides commands to access the storage media and to save and reload instrument settings.

File and directory names

The <file_name> and <directory_name> parameters are strings. Some commands use a fixed directory; for others the <file_name> can contain the complete path including the drive name and all subdirectories, e.g. 'C:\TEMP\TRASH\test.txt' for the file named test.txt in the TEMP\TRASH subdirectory of the internal hard disk drive C:\. If no complete path is specified, the file location is relative to the current directory, queried with MMEMory:CDIRectory?. The file name itself may contain the period as a separator for extensions.

File and directory names can be chosen according to Windows™ conventions; the restrictions placed on file names known from DOS systems do not apply. All letters and numbers are allowed, as well as the special characters "_", "^", "\$", "~", "!", "#", "%", "&", "-", "{", "}", "(", ")", "@", and "'". Reserved file names are CON, AUX, COM1, ..., COM4, LPT1, ..., LPT3, NUL and PRN.

The use of wildcards ? and * is not allowed.

MMEMory:DRIVes?.....	914
MMEMory:MSIS.....	914
MMEMory:DCATalog?.....	914
MMEMory:DCATalog:LENGth?.....	914
MMEMory:CDIRectory.....	915
MMEMory:MDIRectory.....	915
MMEMory:RDIRectory.....	915
MMEMory:CATalog?.....	915
MMEMory:CATalog:LENGth?.....	916
MMEMory:COPI.....	916
MMEMory:MOVE.....	917
MMEMory:DELeTe.....	917
MMEMory:DATA.....	918
MMEMory:ATTRibute.....	918
MMEMory:SAV.....	919
MMEMory:RCL.....	919
MMEMory:STORe:STATe.....	919
MMEMory:LOAD:STATe.....	920

MMEMory:DRIVes?

Returns a list of the logical drives of the instrument as configured in the operating system.

Return values:

<Drive> List of strings, for example, "C:\", "F:\", "H:\"

Usage: Query only

MMEMory:MSIS [<msus>]

Changes the default storage device to the indicated drive or network server.

Parameters:

<msus> String parameter. Drives are indicated with their drive letter, network servers require the UNC format.

Example: `MMEM:MSIS 'C:'`

Example: `MMEM:MSIS '\\server1\share1'`

MMEMory:DCATalog? [<PathName>]

Returns the subdirectories of the current or of a specified directory.

Query parameters:

<PathName> String parameter to specify the directory. If the directory is omitted, the command queries the contents of the current directory, to be set and queried with [MMEMory:CDIRectory](#).

Return values:

<FileEntry> Names of the subdirectories separated by colons. The first two strings are related to the parent directory.

Example: `MMEM:DCAT?`
`".", "..", "Documents and Settings", "Program Files", "temp"`

Usage: Query only

MMEMory:DCATalog:LENGth? [<PathName>]

Returns the number of subdirectories of the current or of a specified directory. The number includes the parent directory strings "." and ".." and corresponds to the number of strings returned by the [MMEMory:DCATalog?](#) command.

Query parameters:

<PathName> String parameter to specify the directory. If the directory is omitted, the command queries the contents of the current directory, to be set and queried with [MMEMory:CDIRectory](#).

Return values:

<FileEntryCount> Number of parent and subdirectories.

Example: MMEM:DCAT:LENG?
5

Usage: Query only

MMEMory:CDIRectory [<DirectoryName>]

Changes the default directory for file access.

Parameters:

<DirectoryName> String parameter to specify the directory. If the string also contains a drive letter or network server name, the command [MMEMory:MSIS](#) is executed implicitly.

*RST: "\

Example: MMEM:CDIR 'C:\USER\DATA'

Usage: SCPI confirmed

MMEMory:MDIRectory <DirectoryName>

Creates a new directory with the specified name.

Setting parameters:

<DirectoryName> String parameter to specify the new directory. If the path consists of several subdirectories, the complete tree will be created if necessary. If no drive letter or server name is indicated, the directory is created on the default storage device specified with [MMEMory:MSIS](#).

Example: MMEM:MDIR 'C:\USER\DATA'

Usage: Setting only

MMEMory:RDIRectory <DirectoryName>

Deletes the specified directory.

Setting parameters:

<DirectoryName> String parameter to specify the directory to be deleted.

Example: MMEM:RDIR 'C:\USER\TEST'

Usage: Setting only

MMEMory:CATalog? [<PathName>][, <Format>]

Returns the a list of files contained in the specified directory. The result corresponds to the number of files returned by the [MMEMory:CATalog:LENGth](#) command.

Query parameters:

<PathName>	String parameter to specify the directory. If the directory is omitted, the command queries directory specified with MMEMory:CDIRectory .
<Format>	ALL WTIME ALL: Extended result including file, date, time and attributes WTIME: Extended result including file, date, time

Return values:

<UsedMemory>	Total amount of storage currently used in the directory, in bytes.
<FreeMemory>	Total amount of storage available in the directory, in bytes.
<FileEntry>	All files and subdirectories of the directory are listed with their file name, format and size in bytes. The first two strings are related to the parent directory.

Example:

```
MMEM:CAT 'C:\USER\DATA'?
529479,1831777894400,".,DIR,0","..,DIR,0",
"Backup,DIR,0","CSS,DIR,0","DATEN,DIR,0",
"Commands.jar,BIN,529479","FAVORITES,DIR,0",
"LOG,DIR,0","DATA,DIR,0","test,DIR,0",
"TotalCMD,DIR,0"
```

Usage:	Query only SCPI confirmed
---------------	------------------------------

MMEMory:CATalog:LENGth? [<PathName>]

Returns the number of files and subdirectories of the current or specified directory. The number includes the parent directory strings "." and ".." and it corresponds to the number of <FileEntry> strings returned by the [MMEMory:CATalog?](#) command.

Query parameters:

<PathName>	String parameter, directory to be queried. If the directory is omitted, the current directory is queried, specified with MMEMory:CDIRectory .
------------	---

Return values:

<Count>	Number of files and subdirectories including parent directory entries.
---------	--

Example:

```
MMEM:CAT:LENG?
11
```

Usage:	Query only
---------------	------------

MMEMory:COPY <FileSource>[, <FileDestination>]

Copies an existing file to a new file.

Setting parameters:

- <FileSource> String parameter, contains name and path of the file to be copied. Wildcards (* and ?) are allowed.
- <FileDestination> String parameter, contains name and path of the new file. If the file already exists, it is overwritten without notice. If no file destination is specified, the source file is written to the current directory specified with [MMEMory:CDIRectory](#).

Example:

```
MMEM: COPY 'C:\Documents and Settings\All Users\
Documents\Rohde-Schwarz\RTO\RefWaveforms\
RefCurve_2011-03-16*.bin', 'E:'
```

Copies all reference waveforms saved on March 16, 2011 to an external storage medium, mapped to drive E:\.

Usage:

Setting only
SCPI confirmed

MMEMory:MOVE <FileSource>, <FileDestination>

Moves the specified file to a new location on the same drive and renames it.

Setting parameters:

- <FileSource> String parameter, contains name and path of the file to be copied. Wildcards (* and ?) are allowed. Therefore, specify a directory for <FileDestination>. Renaming is not possible.
- <FileDestination> String parameter, contains name and path of the new file. If no path is specified, the <FileSource> directory is used - the file is renamed.

Example:

```
MMEM: MOVE 'C:\USER\DATA\SETUP.CFG', 'C:\STORE'
```

Moves the file "Setup.cfg" from the directory C:\USER\DATA to C:\STORE.

Usage:

Setting only
SCPI confirmed

MMEMory:DELeTe <FileName>

Removes the specified file(s). To delete directories, use [MMEMory:RDIRectory](#) on page 915.

Setting parameters:

- <FileName> String parameter to specify the name and directory of the file to be removed. Wildcards (* and ?) are allowed. If no path is defined, the current directory is used, specified with [MMEMory:CDIRectory](#).

Example:

```
MMEM: DEL '* .CFG'
```

Deletes all cfg files from the current directory.

Usage: Setting only
SCPI confirmed

MMEMory:DATA <FileName>, <Data>

MMEMory:DATA? <FileName>

Stores data in the specified file to the storage location specified using [MMEMory:CDIRectory](#).

Parameters:

<Data> <block>
488.2 block data format. The delimiter EOI must be selected to achieve correct data transfer.
The block begins with character '#'. The next digit is the length of the length information, followed by this given number of digits providing the number of bytes in the following binary data.

Parameters for setting and query:

<FileName> String parameter, the name of the file the data is stored to.

Example: MMEM:DATA 'abc.txt' #216This is the file
#2: the length information has two digits
16: the binary data has 16 bytes

MMEMory:ATTRibute <FileName>, <Attributes>

MMEMory:ATTRibute? <FileName>

Sets file attributes for the specified file(s). The command can be used for files only.

Setting parameters:

<Attributes> String with attributes and setting information.
'+' before the attribute: sets the attribute
'-' before the attribute: deletes the attribute
'R': read only
'A': archive file
'S': system file
'H': hidden file

Parameters for setting and query:

<FileName> String parameter, contains name and path of the file. Wildcards (* and ?) are allowed.

Return values:

<FileEntry> String containing: "<file_name>,<file_attributes>"

Example: MMEM:ATTR 'C:\USER\DATA*.LOG', '-R -A'
Deletes the read-only and archive attributes from all LOG files in the directory C:\USER\DATA*.LOG.

Example: MMEM:ATTR? 'C:\USER\DATA*.*'
 "Datei1.LOG,A", "Datei2.LOG,A",
 "Datei3.LOG,ASH", "Datei4.DLL,RSH",
 "Datei5.INI,SH"

MMEMory:SAV <FileDestination>

Stores the current instrument settings to the specified file.

This command has the same effect as the combination of *SAV and MMEMory:STORe:STATe.

Parameters:

<FileDestination> String parameter specifying path and filename of the target file. Wildcards are not allowed.

Example: MMEM:SAV 'C:\mysavefile.dfl'
 Saves the current instrument settings to the file mysavefile.dfl located in the directory C:\.

Usage: Event

MMEMory:RCL <FileSource>

Restores the instrument settings from the specified file.

This command has the same effect as the combination of MMEMory:LOAD:STATe and *RCL.

Parameters:

'<FileSource>' String parameter specifying the path and filename of the source file. Wildcards are not allowed.

Example: MMEM:RCL 'C:\mysavefile.dfl'
 Loads and activates the instrument settings from the file mysavefile.dfl located in the directory C:\.

Usage: Event

MMEMory:STORe:STATe <MemoryNumber>, <FileName>

Stores the instrument settings from the specified internal memory to the specified file. To store the current instrument settings to the internal memory, use *SAV first.

Setting parameters:

<MemoryNumber> Number of the internal memory
 Range: 1 to 99

<FileName> String parameter specifying the complete path and filename of the source file.

Example: *SAV 4
 MMEM:STORe:STATe 4, 'C:
 \Settings\Settings_1051.dfl'
 Saves current instrument settings to the internal memory number 4. Then stores the settings from the internal memory number 4 to the file C:\Settings\Settings_1051.dfl.

Usage: Setting only

MMEMory:LOAD:STATe <MemoryNumber>, <FileName>

Loads the instrument settings from the specified file to the specified internal memory. After the file has been loaded, the settings must be activated using a *RCL command.

Setting parameters:

<MemoryNumber> Number of the internal memory
 Range: 1 to 99

<FileName> String parameter specifying the complete path and filename of the source file.

Example: MMEM:LOAD:STATe 4, 'C:
 \Settings\Settings_1051.dfl'
 *RCL 4
 Loads instrument settings from the file C:\Settings\Settings_1051.dfl to the internal memory number 4, and then activates the settings in internal memory number 4.

Usage: Setting only

21.2.15.2 Waveform Data Export

EXPort:WAVeform:NAME.....	921
EXPort:WAVeform:SAVE.....	921
EXPort:WAVeform:MULTichannel.....	921
EXPort:WAVeform:SOURce.....	921
CHANnel<m>:EXPortstate.....	922
EXPort:WAVeform:SCOPE.....	922
EXPort:WAVeform:START.....	923
EXPort:WAVeform:STOP.....	923
EXPort:WAVeform:ZOOM.....	923
EXPort:WAVeform:CURSorset.....	923
EXPort:WAVeform:MEAS.....	924
EXPort:WAVeform:DLOGging.....	924
EXPort:WAVeform:INCXvalues.....	925
EXPort:WAVeform:RAW.....	925
EXPort:WAVeform:DISPlayoff.....	926
EXPort:WAVeform:FASTexport.....	926

EXPort:WAVeform:NAME <FileName>

Sets the file name, file format and path to save the waveform to.

See also: [chapter 11.2.2.1, "Waveform File Formats"](#), on page 369

Parameters:

<FileName> String with path and file name with extension .xml, .bin, or .csv

Example:

```
EXPort:WAVeform:NAME 'C:\temp\Export_Ch1.xml'
EXPort:WAVeform:SAVE
```

Saves the waveform data in XML format to
C:\temp\Export_Ch1.xml.

Example:

```
EXPort:WAVeform:NAME 'C:\temp\Export_Ch2.bin'
EXPort:WAVeform:SAVE
```

Saves the waveform data in binary format to
C:\temp\Export_Ch2.bin.

Firmware/Software: V 1.25

EXPort:WAVeform:SAVE

Saves the waveform(s) to the file specified with [EXPort:WAVeform:NAME](#). The file format is also set using the `...NAME` command.

Example:

See [chapter 21.3.5.2, "Exporting Waveform Data to File"](#), on page 1132

Usage:

Event

Firmware/Software: V 1.25

EXPort:WAVeform:MULTichannel <MultiChExport>

Enables or disables the multichannel export.

If enabled, select the channels to be exported using the [CHANnel<m>:EXPortstate](#) command.

If disabled, select the waveform to be exported using the [EXPort:WAVeform:SOURce](#) command.

Parameters:

<MultiChExport> ON | OFF
*RST: OFF

EXPort:WAVeform:SOURce <Source>

Selects the waveform to be exported from the active waveforms of input channels, math signals, reference waveforms and digital channels.

The commands takes effect if [EXPort:WAVeform:MULTichannel](#) is OFF.

Parameters:

<Source> C1W1 | C1W2 | C1W3 | C2W1 | C2W2 | C2W3 | C3W1 | C3W2 |
C3W3 | C4W1 | C4W2 | C4W3 | M1 | M2 | M3 | M4 | R1 | R2 |
R3 | R4 | D0 | D1 | D2 | D3 | D4 | D5 | D6 | D7 | D8 | D9 | D10 |
D11 | D12 | D13 | D14 | D15

Example: See [chapter 21.3.5.2, "Exporting Waveform Data to File"](#),
on page 1132

Firmware/Software: V 1.25

CHANnel<m>:EXPortstate <ExportState>

Includes or excludes the indicated channel in waveform export. The data of channel waveform 1 is exported.

The commands takes effect if `EXPort:WAVeform:MULTichannel` is ON.

Suffix:

<m> 1..4
Selects the input channel.

Parameters:

<ExportState> ON | OFF
*RST: OFF

EXPort:WAVeform:SCOPE <Scope>

Defines the part of the waveform record that has to be stored.

Parameters:

<Scope> WFM | ZOOM | CURSor | GATE | MANual

WFM
Complete waveform

ZOOM
Data included in the zoom area if a zoom is defined for the source waveform.

CURSor
Data between the cursor lines if a cursor measurement is defined for the source waveform.

GATE
data included in the measurement gate if a gated measurement is defined for the source waveform.

MANual
Saves the data between user-defined start and stop values to be set with `EXPort:WAVeform:START` and `EXPort:WAVeform:STOP`.

*RST: WFM

Example: See [chapter 21.3.5.2, "Exporting Waveform Data to File"](#), on page 1132

Firmware/Software: V 1.25

EXPort:WAVeform:START <Start>

Sets the start value of the waveform section for export, if `EXPort:WAVeform:SCOPE` is set to `Manual`.

Parameters:

<Start>	Range:	-100E+24 to 100E+24
	Increment:	0.01
	*RST:	0.01
	Default unit:	s

Firmware/Software: V 1.25

EXPort:WAVeform:STOP <Stop>

Sets the end value of the waveform section for export, if `EXPort:WAVeform:SCOPE` is set to `Manual`.

Parameters:

<Stop>	Range:	-100E+24 to 100E+24
	Increment:	0.01
	*RST:	0.01
	Default unit:	s

Firmware/Software: V 1.25

EXPort:WAVeform:ZOOM <DiagramName>, <ZoomName>

EXPort:WAVeform:ZOOM? <DiagramName>

Sets the zoom area to be used for limited data export if `EXPort:WAVeform:SCOPE` is set to `ZOOM`.

Parameters:

<ZoomName>	Name of the zoom diagram
------------	--------------------------

Parameters for setting and query:

<DiagramName>	Name of the diagram on which the zoom area is based.
---------------	--

Example: See ["Exporting Interleaved x/y Data of a Zoom to CSV File"](#) on page 1134

Firmware/Software: V 1.25

EXPort:WAVeform:CURSorset <Cursorset>

Sets the cursor set to be used for limited data export if `EXPort:WAVeform:SCOPE` is set to `CURSor`.

Parameters:

<Cursorset> CURSOR1 | CURSOR2 | CURSOR3 | CURSOR4
 *RST: CURSOR1

Firmware/Software: V 1.25

EXPort:WAVeform:MEAS <MeasGate>

Sets the gate to be used for limited data export if `EXPort:WAVeform:SCOPE` is set to GATE.

Parameters:

<MeasGate> MEAS1 | MEAS2 | MEAS3 | MEAS4 | MEAS5 | MEAS6 |
 MEAS7 | MEAS8 | IMEAS
 Measurement for which the gate is defined.
 *RST: MEAS1

Example: See ["Exporting Raw Data of a Measurement Gate to BIN File"](#)
 on page 1133

Firmware/Software: V 1.25

EXPort:WAVeform:DLOGging <DataLogging>

The command enables the export of subsequent acquisitions of the selected waveforms. The waveforms are taken from a running Nx Single acquisition (data logging, history is disabled), or from the history (multiple waveforms, history is enabled).

If the history is disabled (`CHANnel<m>[:WAVeform<n>]:HISTory[:STATE]`) and data logging is enabled, a specified number of waveforms is transferred to file directly during RUN Nx SINGLE acquisition. Enabling data logging stops a running acquisition. Set the number of acquisitions to be acquired and stored with `ACQUIRE:COUNT` and start export using `RUNSingle`.

If the history is enabled, the subsequent waveforms are taken from the history. Specify the range with `CHANnel<m>[:WAVeform<n>]:HISTory:START` and `CHANnel<m>[:WAVeform<n>]:HISTory:STOP`. Then play the history with `CHANnel<m>[:WAVeform<n>]:HISTory:PLAY`.

The commands `EXPort:WAVeform:SAVE`, `CHANnel<m>[:WAVeform<n>]:DATA[:VALUES]?` and `CHANnel<m>[:WAVeform<n>]:DATA:HEADER?` are not available if data logging is enabled. The `RUNContinuous` command disables data logging.

If data logging is off, and the history is enabled, one waveform out of the history is written to file. Specify the waveform using `CHANnel<m>[:WAVeform<n>]:HISTory:CURRENT` and save it using `EXPort:WAVeform:SAVE`.

Parameters:

<DataLogging> ON | OFF
 *RST: OFF

Example: See:
["Exporting Multiple Running Acquisitions of a Single Waveform to XML File"](#) on page 1134
["Exporting Multiple Acquisition of the History to XML File"](#) on page 1135
["Exporting a Single Acquisition of the History to BIN File"](#) on page 1134

Firmware/Software: V 1.25

EXPort:WAVeform:INCXvalues <IncHorValues>

Includes horizontal values in the retrieved data (time or frequency values, depending on the waveform). X and Y-values are written alternately to the file. If disabled, only Y-values - mostly voltage values - are written. The X-values are always returned in 64 bit real format, regardless of the defined data format.

The setting is not available for the export of raw data.

The command affects the content of export files as well as data retrieved with:

- [CHANnel<m> \[:WAVeform<n> \] :DATA \[:VALues \] ?](#)
- [CALCulate:MATH<m> :DATA \[:VALues \] ?](#)
- [REFCurve<m> :DATA \[:VALues \] ?](#)

Parameters:

<IncHorValues> ON | OFF
 *RST: OFF

Example: See:
["Exporting Interleaved x/y Data of a Single Waveform to CSV File"](#) on page 1133
["Exporting Interleaved x/y Data of a Zoom to CSV File"](#) on page 1134

Firmware/Software: FW 1.40

EXPort:WAVeform:RAW <RawValues>

Enables the export of raw sample data of the ADC, and sets the data format in binary files to integer 8 bit. This format reduces the file size but decreases also the precision of the values.

The setting is not available for the export of digital channel data and for the export of interleaved X/Y values.

Parameters:

<RawValues> ON | OFF
 *RST: OFF

Example: See:
["Exporting Raw Data of a Single Waveform to BIN File"](#)
 on page 1132
["Exporting Raw Data of a Measurement Gate to BIN File"](#)
 on page 1133

Firmware/Software: FW 1.40

EXPort:WAVeform:DISPlayoff <FastExport>

Enables or disables the display update during an Nx SINGLE acquisition.

Parameters:

<FastExport> ON | OFF
 ON: Disables the display update for maximum export speed.
 OFF: Enables the display update. The export is slower.
 *RST: OFF

Firmware/Software: V 2.00

EXPort:WAVeform:FASTexport <Enable>

To improve the performance of data export to file, the measurements are performed slower while the data export speeds up.

Setting parameters:

<Enable> ON | OFF

Example: See [chapter 21.3.5.2, "Exporting Waveform Data to File"](#),
 on page 1132

Usage: Setting only

Firmware/Software: V 1.47

21.2.15.3 Waveform Histogram Export

EXPort:HISTogram:SElect	926
EXPort:HISTogram:INCidence	927
EXPort:HISTogram:NAME	927
EXPort:HISTogram:SAVE	927
EXPort:HISTogram:DATA?	927

EXPort:HISTogram:SElect <Name>

Selects the histogram to be exported.

Parameters:

<Name> String with the histogram name.

Example: See ["Exporting Histogram Data to File"](#) on page 1129

Firmware/Software: V 1.47

EXPort:HISTogram:INCidence <Incidence>

Sets the mode of exported data: relative or absolute frequency of amplitude values.

Parameters:

<Incidence> ABS | REL
 *RST: REL

Example: See "[Exporting Histogram Data to File](#)" on page 1129

Firmware/Software: V 1.47

EXPort:HISTogram:NAME <Path>

Sets the file name and path to save the histogram to.

Parameters:

<Path> String with path and file name. The file extension defines the file format: XML, CSV, or BIN.

Example: See "[Exporting Histogram Data to File](#)" on page 1129

Firmware/Software: V 1.47

EXPort:HISTogram:SAVE

Saves the histogram to the file specified with [EXPort:HISTogram:NAME](#).

Example: See "[Exporting Histogram Data to File](#)" on page 1129

Usage: Event

Firmware/Software: V 1.47

EXPort:HISTogram:DATA?

Transfers the histogram data to the controlling computer. The data can be used in MATLAB, for example.

To set the export data format, use [FORMat \[:DATA \]](#).

Return values:

<Data> List of values according to the format settings and [EXPort:HISTogram:INCidence](#).
 See also: [chapter 11.2.2.3, "Waveform Histograms"](#), on page 379

Example: See "[Transferring Histogram Data](#)" on page 1129

Usage: Query only

Firmware/Software: V 1.47

21.2.15.4 Long Term Measurement Results and Measurement Histogram Export

EXPort:MEASurement:SElect.....	928
EXPort:MEASurement:TYPE.....	928
EXPort:MEASurement:NAME.....	928
EXPort:MEASurement:SAVE.....	929
EXPort:MEASurement:DATA?.....	929

EXPort:MEASurement:SElect <SelectedMeas>

Selects the measurement for export of long term or measurement histogram data.

Parameters:

<SelectedMeas> MEAS1 | MEAS2 | MEAS3 | MEAS4 | MEAS5 | MEAS6 |
MEAS7 | MEAS8
*RST: MEAS1

Example: See "[Exporting Long Term Measurement Data to File](#)"
on page 1130

Firmware/Software: V 1.47

EXPort:MEASurement:TYPE <ExportType>

You can export the result data of the long term measurement, or the measurement histogram.

To export the measurement histogram, it must be enabled using [MEASurement<m>:STATistics:HISTogram](#).

To export the long term results, the long term measurement must be enabled using [MEASurement<m>:LTMeas\[:STATE\]](#).

Parameters:

<ExportType> LONGTERM | HISTOGRAM
*RST: HISTOGRAM

Example: See "[Exporting Long Term Measurement Data to File](#)"
on page 1130

Firmware/Software: V 1.47

EXPort:MEASurement:NAME <Path>

Sets the file name and path to save the long term or measurement histogram data to.

Parameters:

<Path> String with path and file name. The file extension defines the file format: XML, CSV, or BIN.

Example: See "[Exporting Long Term Measurement Data to File](#)"
on page 1130

Firmware/Software: V 1.47

EXPort:MEASurement:SAVE

Saves the long term or measurement histogram results to the file specified using [EXPort:MEASurement:NAME](#).

The measurement data can be exported as absolute or relative values, which is defined using [EXPort:HISTogram:INCidence](#).

Example: See ["Exporting Long Term Measurement Data to File"](#) on page 1130

Usage: Event

Firmware/Software: V 1.47

EXPort:MEASurement:DATA?

Transfers the long term measurement data to the controlling computer. The data can be used in MATLAB, for example.

To set the export data format, use [FORMat\[:DATA\]](#).

Return values:

<Data> List of values according to the format settings
 Long term data:
 If statistics are enabled ([MEASurement<m>:STATistics\[:ENABLE\]](#)), six values for each long term point are returned: maximum, minimum, average, standard deviation, number of measured results per long term point, number of waveforms per long term point.
 If statistics are disabled, the current value of each long term point is returned.
 For measurement histograms, absolute values are returned.
 See also: [chapter 11.2.2.5, "Long Term / Meas Histograms"](#), on page 382

Example: See ["Transferring Long Term Measurement Data"](#) on page 1130

Usage: Query only

Firmware/Software: V 1.47

21.2.15.5 Screenshots

The HCOPY subsystem and some other commands control the output of display information for documentation purposes on output devices (printer and clipboard) or files. The instrument allows two independent output configurations which can be set separately with the suffix.

HCOPY:DESTination<1..2>	930
MMEMory:NAME	930
HCOPY:DEVice<m>:LANGuage	931

HCOPY:PAGE:ORientation<1..2>.....	931
HCOPY:DEvice<m>:COLor.....	931
HCOPY:DEvice<m>:INVerse.....	931
HCOPY:CMAP<m>:DEFault.....	932
HCOPY:IMMediate<m>[:DUM].....	932
HCOPY:IMMediate<m>:NEXT.....	932
SYSTem:COMMunicate:PRINter:ENUMerate:FIRSt?.....	933
SYSTem:COMMunicate:PRINter:ENUMerate[:NEXT]?.....	933
SYSTem:COMMunicate:PRINter:SElect<1..2>.....	933

HCOPY:DESTination<1..2> <Medium>

Selects the output medium: file, printer or clipboard.

Suffix:

<1..2> Selects the output configuration.

Parameters:

<Medium> MMEM | SYST:COMM:PRIN | SYST:COMM:CLIP

String parameter

MMEM

Directs the display image to a file. The `MMEMory:NAME` command defines the file name. The file format is defined with `HCOPY:DEvice<m>:LANGuage`.

SYST:COMM:PRIN

Directs the display image to the printer. The printer is selected with the `SYSTem:COMMunicate:PRINter:SElect<1..2>` command. The `HCOPY:DESTination` command should always be sent after setting the printer.

SYST:COMM:CLIP

Directs the hardcopy to the clipboard.

*RST: SYST:COMM:CLIP

Example:

HCOPY:DEST 'SYST:COMM:PRIN'

See also [chapter 21.3.5.1, "Saving a Screenshot to File"](#), on page 1131

MMEMory:NAME <FileName>

Defines the file name when an image of the display is stored to a file rather than printed to a printer using the `HCOPY:IMMediate<m>[:DUM]` command.

Setting parameters:

<FileName> String parameter specifying path and file name of the screenshot

Example:

See [chapter 21.3.5.1, "Saving a Screenshot to File"](#), on page 1131

Usage:

Setting only
SCPI confirmed

HCOPY:DEVICE<m>:LANGUage <FileFormat>

Defines the file format for output of the display image to file.

To set the output to file, use `HCOPY:DESTINATION<1..2>` with parameter 'MMEM'.

Suffix:

<m> 1..2
Selects the output configuration.

Parameters:

<FileFormat> PNG | JPG | BMP | TIFF | PDF
*RST: PNG

Example:

See [chapter 21.3.5.1, "Saving a Screenshot to File"](#), on page 1131

HCOPY:PAGE:ORientation<1..2> <Orientation>

Defines the page orientation for output of the display image to a printer.

To set the output to printer, use `HCOPY:DESTINATION<1..2>` with parameter 'SYST:COMM:PRIN'.

Suffix:

1..2 Selects the output configuration.

Parameters:

<Orientation> PORTRait | LANDscape
*RST: LANDscape

HCOPY:DEVICE<m>:COLor <Color>

Selects between color and monochrome printing of the display image.

To set the output to printer, use `HCOPY:DESTINATION<1..2>` with parameter 'SYST:COMM:PRIN'.

Suffix:

<m> 1..2
Selects the output configuration.

Parameters:

<Color> ON | OFF
ON: Color output
OFF: Black and white output
*RST: ON

HCOPY:DEVICE<m>:INVerse <InverseColor>

Inverts the colors of the output, i.e. a dark waveform is printed on a white background.

Suffix:

<m> 1..2
Selects the output configuration.

Parameters:

<InverseColor> ON | OFF
*RST: ON

Firmware/Software: V 1.27

HCOPY:CMAP<m>:DEFault <PrintColorSet>

Defines the default color set for printing of the display image.

To set the output to printer, use [HCOPY:DESTination<1..2>](#) with parameter 'SYST:COMM:PRIN'.

Suffix:

<m> 1..2
Selects the output configuration.

Parameters:

<PrintColorSet> DEF1 | DEF4
DEF1
Current screen colors with white background and black grid.
DEF4
Current screen colors without any changes (black background).
*RST: DEF1

HCOPY:IMMEDIATE<m>[:DUM]

Starts the immediate output of the display image to printer, file, or clipboard, depending on the [HCOPY:DESTination<1..2>](#) setting.

Suffix:

<m> 1..2
Selects the output configuration.

Example: See [chapter 21.3.5.1, "Saving a Screenshot to File"](#), on page 1131

Usage: Event

HCOPY:IMMEDIATE<m>:NEXT

Starts the output of the next display image to printer, file, or clipboard, depending on the [HCOPY:DESTination<1..2>](#) setting.

If the output is printed to a file, the file name used in the last saving process is automatically counted up to the next unused name.

Suffix:
<m> 1..2
Selects the output configuration.

Example: See [chapter 21.3.5.1, "Saving a Screenshot to File"](#), on page 1131

Usage: Event

SYSTem:COMMunicate:PRINter:ENUMerate:FIRSt?

Queries the name of the first printer in the list of printers that is configured in the Windows operating system.

To query the names of other installed printers, use the `SYSTem:COMMunicate:PRINter:ENUMerate[:NEXT]?` command.

Return values:
<PrinterName> If no printer is configured an empty string is returned.

Usage: Query only

SYSTem:COMMunicate:PRINter:ENUMerate[:NEXT]?

Queries the name of the next printer that is configured in the Windows operating system.

Before you send the ...NEXT command, send `SYSTem:COMMunicate:PRINter:ENUMerate:FIRSt?` to return to the beginning of the printer list and query the name of the first printer.

Return values:
<PrinterName> After all available printer names have been returned, an empty string enclosed by quotation marks (") is returned for the next query. Further queries are answered by a query error.

Usage: Query only

SYSTem:COMMunicate:PRINter:SELEct<1..2> <PrinterName>

Selects a configured printer.

Parameters:
<PrinterName> Enter the string as it is returned with `SYSTem:COMMunicate:PRINter:ENUMerate:FIRSt?` or `SYSTem:COMMunicate:PRINter:ENUMerate[:NEXT]?`.

21.2.16 General Instrument Setup

This chapter describes commands related to SETUP > "System" and "File" > "Exit". For commands related to SETUP > "Remote Settings", see [chapter 21.2.5, "General Remote Settings"](#), on page 673.

SYSTem:EXIT.....	934
SYSTem:PRESet.....	934
SYSTem:RESet.....	934
SYSTem:DATE.....	934
SYSTem:TIME?.....	935
SYSTem:DEVice:ID?.....	935
DIAGnostic:SERVice:FWVersion?.....	935
DIAGnostic:SERVice:COMPutername.....	935
DIAGnostic:SERVice:PARTnumber.....	936
DIAGnostic:SERVice:SERialnumber?.....	936
SYSTem:VERSion?.....	936
SYSTem:DFPRint.....	936
SYSTem:ERRor:ALL?.....	936
SYSTem:ERRor[:NEXT]?.....	937
SYSTem:ERRor:CODE:ALL?.....	937
SYSTem:ERRor:CODE[:NEXT]?.....	937
SYSTem:ERRor:COUNT?.....	938

SYSTem:EXIT

Starts the shutdown of the firmware.

Usage: Event

SYSTem:PRESet

Resets the instrument to the factory default settings, to the initial state. Factory settings comprise all instrument settings, including display, intensity and transparency settings. After loading factory defaults, perform a self-alignment to synchronize the signal data.

Usage: Event

SYSTem:RESet

Resets the instrument settings to defaults appropriate for remote control of the instrument. The last loaded user-defined preset is used. The command is equivalent to *RST.

Usage: Event

SYSTem:DATE <Year>, <Month>, <Day>

Sets the date of the internal calendar.

Parameters:

<Year>	Year, to be entered as a four-digit number (including the century and millenium information)
<Month>	Month, 1 (January) to 12 (December)
<Day>	Day, 1 to the maximum number of days in the specified month
*RST:	does not affect the date settings

Example:

SYSTem:DATE?
Returned value: 2011, 09, 13

Usage:

SCPI confirmed

SYSTem:TIME? <Hour>, <Minute>, <Second>

Returns the UTC (Universal Time Coordinated) of the internal clock. To define the current local time, use the time zone setting of the operating system (SETUP > "Time, date")

Example:

SYSTem:TIME?
Returned value: 15, 09, 20. UTC is 15:09:20.

Usage:

Query only
SCPI confirmed

SYSTem:DEvice:ID?

Returns the instrument ID - that is the material number and the serial number

Return values:

<ID> String containing the material number and the serial number

Example:

1316.1000K24-001122-jT

Usage:

Query only

DIAGnostic:SERvice:FWVersion?

Returns the firmware version that is currently installed on the instrument.

Return values:

<FirmwareVersion> Version string

Usage:

Query only

DIAGnostic:SERvice:COMPutername <ComputerName>

Returns the computer name that is currently defined. The computer name is required when configuring a network.

Parameters:

<ComputerName> Name string

DIAGnostic:SERVice:PARTnumber <MaterialNumber>

Returns the material number of your instrument. This number is required to order a new option, and in case of service.

Parameters:

<MaterialNumber> Number string

DIAGnostic:SERVice:SERialnumber?

Returns the serial number of your instrument. This number is required to order a new option, and in case of service.

Return values:

<SerialNumber> Number string

Usage: Query only

SYSTem:VERSion?

Queries the SCPI version number to which the instrument complies. The instrument complies to the final SCPI version 1999.0.

Usage: Query only
 SCPI confirmed

SYSTem:DFPRint [<Path>]

The device footprint contains the configuration of the instrument, installed modules, installed software and software licenses. This information is written in the device footprint xml file might be useful in case of maintenance or support request.

The query returns the information as block data. The setting command saves the device footprint xml file in the specified path.

It is also possible to access the device footprint xml file via the LXI web browser. Therefore, the directory containing the xml file must be enabled for sharing.

Setting parameters:

<Path> String parameter, specifying the target path of the footprint file.

Return values:

<DeviceFootprint> Content of the device footprint xml file as block data

SYSTem:ERRor:ALL?

Queries the error/event queue for all unread items and removes them from the queue. The response is a comma separated list of error number and a short description of the error in FIFO order.

Positive error numbers are instrument-dependent. Negative error numbers are reserved by the SCPI standard.

Return values:

<Error> List of: Error/event_number,"Error/event_description">[:Device-dependent info]"
If the queue is empty, the response is 0,"No error"

Usage:

Query only
SCPI confirmed

SYSTem:ERRor[:NEXT]?

Queries the error/event queue for the oldest item and removes it from the queue. The response consists of an error number and a short description of the error.

Positive error numbers are instrument-dependent. Negative error numbers are reserved by the SCPI standard.

Return values:

<Error> Error/event_number,"Error/event_description">[:Device-dependent info]"
If the queue is empty, the response is 0,"No error"

Usage:

Query only
SCPI confirmed

SYSTem:ERRor:CODE:ALL?

Queries the error/event queue for all unread items and removes them from the queue. The response is a comma separated list of error numbers in FIFO order.

Positive error numbers are instrument-dependent. Negative error numbers are reserved by the SCPI standard.

Return values:

<Error> If the queue is empty, the response is 0

Usage:

Query only
SCPI confirmed

SYSTem:ERRor:CODE[:NEXT]?

Queries the error/event queue for the oldest item and removes it from the queue. The response is the error number.

Positive error numbers are instrument-dependent. Negative error numbers are reserved by the SCPI standard.

Return values:

<Error> If the queue is empty, the response is 0

Usage:

Query only
SCPI confirmed

SYSTem:ERRor:COUNT?

Queries the number of entries in the error queue.

Return values:

<Count> If the queue is empty, the response is 0

Usage:

Query only
SCPI confirmed

21.2.17 Protocols

- [General Setup](#)..... 938
- [I²C](#) 940
- [SPI](#)..... 958
- [UART](#)..... 971
- [CAN \(Option R&S RTO-K3\)](#)..... 980
- [LIN \(Option R&S RTO-K3\)](#)..... 996
- [FlexRay \(Option R&S RTO-K4\)](#)..... 1012
- [Audio Signals \(Option R&S RTO-K5\)](#)..... 1033

21.2.17.1 General Setup

BUS<m>:TYPE	938
BUS<m>[:STATe]	938
BUS<m>:SETReflevels	939
BUS<m>:LABel	939
BUS<m>:RESult	939
BUSFormat	939

BUS<m>:TYPE <Type>

Defines the bus or protocol type for analysis.

Suffix:

<m> 1..4
Selects the serial bus.

Parameters:

<Type> I2C | SPI | UART | CAN | LIN | FLXRay | I2S
*RST: I2C

Usage:

Asynchronous command

BUS<m>[:STATe] <State>

Switches the protocol display on or off.

Suffix:

<m> 1..4
Selects the serial bus.

Parameters:

<State> ON | OFF
 *RST: OFF

Usage: Asynchronous command

BUS<m>:SETReflevels

Executes the measurement of reference levels and sets the thresholds to the middle reference level of the measured amplitude.

Suffix:

<m> 1..4
 Selects the serial bus.

Usage: Event
 Asynchronous command

Firmware/Software: FW 1.45

BUS<m>:LABel <Label>

Defines a label to be displayed with the bus.

Suffix:

<m> 1..4
 Selects the serial bus.

Parameters:

<Label> String containing the label text.

Usage: Asynchronous command

BUS<m>:RESult <ShowResultTable>

Opens a table with decoded data of the serial signal. The function requires the option for the analyzed protocol.

Suffix:

<m> 1..4
 Selects the serial bus.

Parameters:

<ShowResultTable> ON | OFF
 *RST: OFF

Usage: Asynchronous command

BUSFormat <DataFormat>

Sets the data format for decoded data values in the "Decode results" box and on the display of the decoded signal.

Parameters:

<DataFormat> HEX | OCT | BIN | ASCII | SIGN | USIG
 *RST: HEX

Usage: Asynchronous command

Firmware/Software: FW 1.45

21.2.17.2 I²C

- [Configuration](#)..... 940
- [Trigger](#)..... 942
- [Decoding Results \(Option R&S RTO-K1\)](#)..... 949
- [Label List \(Option R&S RTO-K1\)](#)..... 957

Configuration

BUS<m>:I2C:SCL:SOURce	940
BUS<m>:I2C:SDA:SOURce	940
BUS<m>:I2C:SCL:THReshold	941
BUS<m>:I2C:SDA:THReshold	941
BUS<m>:I2C:TECHnology	941
BUS<m>:I2C:RWBit	942

BUS<m>:I2C:SCL:SOURce <SCLSource>

Sets the waveform of the clock line.

Suffix:

<m> 1..4
 Selects the serial bus.

Parameters:

<SCLSource> C1W1 | C2W1 | C3W1 | C4W1 | M1 | M2 | M3 | M4 | R1 | R2 |
 R3 | R4 | D0 | D1 | D2 | D3 | D4 | D5 | D6 | D7 | D8 | D9 | D10 |
 D11 | D12 | D13 | D14 | D15

Digital and analog channels cannot be used at the same time for data and clock lines.

See [chapter 21.2.3.2, "Waveform Parameter"](#), on page 666

*RST: C1W1

Usage: Asynchronous command

BUS<m>:I2C:SDA:SOURce <SDASource>

Sets the waveform of the data line.

Suffix:

<m> 1..4
 Selects the serial bus.

Parameters:

<SDASource> C1W1 | C2W1 | C3W1 | C4W1 | M1 | M2 | M3 | M4 | R1 | R2 | R3 | R4 | D0 | D1 | D2 | D3 | D4 | D5 | D6 | D7 | D8 | D9 | D10 | D11 | D12 | D13 | D14 | D15

Digital and analog channels cannot be used at the same time for data and clock lines.

See [chapter 21.2.3.2, "Waveform Parameter"](#), on page 666

*RST: C1W1

Usage:

Asynchronous command

BUS<m>:I2C:SCL:THReshold <SCLThreshold>

Sets a user-defined threshold value for the clock line.

Alternatively, you can set the threshold according to the signal technology with [BUS<m>:I2C:TECHnology](#).

Suffix:

<m> 1..4
Selects the serial bus.

Parameters:

<SCLThreshold> User-defined clock threshold
Range: -12 to 12
Increment: 0.1
*RST: 0
Default unit: V

BUS<m>:I2C:SDA:THReshold <SDAThreshold>

Sets a user-defined threshold value for the data line.

Alternatively, you can set the threshold according to the signal technology with [BUS<m>:I2C:TECHnology](#).

Suffix:

<m> 1..4
Selects the serial bus.

Parameters:

<SDAThreshold> User-defined data threshold
Range: -12 to 12
Increment: 0.1
*RST: 0
Default unit: V

BUS<m>:I2C:TECHnology <Technology>

Sets the threshold voltage clock and data lines as defined for various signal technologies.

Suffix:

<m> 1..4
Selects the serial bus.

Parameters:

<Technology> V15 | V25 | V165 | V125 | V09 | VM13 | V38 | V20 | V0 | MAN
V15 | V25 | V165 | V125 | V09 | V38 | V20 | V0
 1.5 V, 2.5 V, 1.65 V ... respectively
VM13
 -1.3 V (negative value)
MAN
 Manual setting of user-defined values with `BUS<m>:I2C:SCL:THReshold` and `BUS<m>:I2C:SDA:THReshold`.
 *RST: V165

Usage: SCPI confirmed

BUS<m>:I2C:RWBit <BusConfig>

Defines if the R/W bit of a 7-bit address is considered separately or as part of the address. The setting defines which address lengths are available with `TRIGger<m>:I2C:AMODE`.

Suffix:

<m> 1..4
Selects the serial bus.

Parameters:

<BusConfig> SEParate | INADdress
SEParate
 Address types BIT7 and BIT10 are available.
INADdress
 Address types BIT7_RW and BIT10 are available.
 *RST: SEParate

Firmware/Software: FW 1.35

Trigger

<code>TRIGger<m>:I2C:MODE</code>	943
<code>TRIGger<m>:I2C:ACCess</code>	943
<code>TRIGger<m>:I2C:ADNack</code>	944
<code>TRIGger<m>:I2C:DWNack</code>	944
<code>TRIGger<m>:I2C:DRNack</code>	944
<code>TRIGger<m>:I2C:AMODE</code>	945
<code>TRIGger<m>:I2C:ACONdition</code>	945
<code>TRIGger<m>:I2C:ADDRess</code>	945
<code>TRIGger<m>:I2C:ADDTTo</code>	946
<code>TRIGger<m>:I2C:ADOR<n>:ENABLE</code>	946
<code>TRIGger<m>:I2C:ADOR<n>:ADRTypE</code>	946

TRIGger<m>:I2C:ADOR<n>[:VALue].....	947
TRIGger<m>:I2C:ADOR<n>:RWBit.....	947
TRIGger<m>:I2C:DPOPerator.....	947
TRIGger<m>:I2C:DPOStion.....	948
TRIGger<m>:I2C:DPTO.....	948
TRIGger<m>:I2C:DCONdition.....	948
TRIGger<m>:I2C:DMIN.....	949
TRIGger<m>:I2C:DMAX.....	949

TRIGger<m>:I2C:MODE <Type>

Selects the trigger type for I²C analysis.

See: "Trigger type" on page 431

Suffix:

<m> 1..3
Event in a trigger sequence: 1 = A-event only

Parameters:

<Type> START | REPStart | STOP | NACK | ADDRess | ADOR | ADAT

START
Start condition

REPStart
Repeated start - the start condition occurs without previous stop condition.

STOP
Stop condition, end of frame

NACK
Missing acknowledge bit. To localize specific missing acknowledge bits, use TRIGger<m>:I2C:ADNack, TRIGger<m>:I2C:DWNack, and TRIGger<m>:I2C:DRNack.

ADDRess
Triggers on one specific address

ADOR
Triggers on an OR combination with up to four address conditions.

ADAT
Triggers on a combination of address and data condition.

*RST: START

Usage: Asynchronous command

TRIGger<m>:I2C:ACCess <RWBitAddress>

Sets the trigger condition for the R/W bit - the transfer direction of the data.

Suffix:

<m> 1..3
Event in a trigger sequence: 1 = A-event only

Parameters:

<RWBitAddress> READ | WRITe | EITHer

EITHer

Transfer direction is not relevant.

*RST: EITHer

Usage:

Asynchronous command

TRIGger<m>:I2C:ADNack <AddressNack>

Triggers if the address acknowledge bit is missing - no slave recognizes the address.

Suffix:

<m> 1..3

Event in a trigger sequence: 1 = A-event only

Parameters:

<AddressNack> ON | OFF

*RST: ON

Usage:

Asynchronous command

TRIGger<m>:I2C:DWNack <DataWriteNack>

Triggers if a data acknowledge bit is missing - the addressed slave does not accept the data.

Suffix:

<m> 1..3

Event in a trigger sequence: 1 = A-event only

Parameters:

<DataWriteNack> ON | OFF

*RST: ON

Usage:

Asynchronous command

TRIGger<m>:I2C:DRNack <DataReadNack>

Triggers on the end of the read process when the master reads data from the slave. This Nack is sent according to the protocol definition, it is not an error.

Suffix:

<m> 1..3

Event in a trigger sequence: 1 = A-event only

Parameters:

<DataReadNack> ON | OFF

*RST: ON

Usage:

Asynchronous command

TRIGger<m>:I2C:AMODe <AddressType>

Sets the address length. The setting affects the address input with [TRIGger<m>:I2C:ADDRESS](#) and [TRIGger<m>:I2C:ADDTTo](#).

Suffix:

<m> 1..3
Event in a trigger sequence: 1 = A-event only

Parameters:

<AddressType> BIT7 | BIT7_RW | BIT10 | ANY
Available address types depend on [BUS<m>:I2C:RWBit SEPa-rate](#) | [INADDRESS](#).

BIT7 | BIT10

Only address bits have to be entered for address.

BIT7_RW

Seven address bits and also the R/W bit have to be entered for address.

ANY

Only available for trigger type "Address + data" ([TRIGger<m>:I2C:MODE ADAT](#)). Used to trigger on data only, regardless of the address.

*RST: BIT7

Usage: Asynchronous command

TRIGger<m>:I2C:ACONdition <AddressOperator>

Sets the operator to set a specific address or an address range. The address values are set with [TRIGger<m>:I2C:ADDRESS](#) and [TRIGger<m>:I2C:ADDTTo](#).

Suffix:

<m> 1..3
Event in a trigger sequence: 1 = A-event only

Parameters:

<AddressOperator> EQUal | NEQUal | LTHan | LETHan | GTHan | GETHan | INRange | OORange
*RST: EQUal

Firmware/Software: V 1.25

TRIGger<m>:I2C:ADDRESS <Address>

Triggers on the specified slave address, or sets the the start value of an address range depending on the condition set with [TRIGger<m>:I2C:ACONdition](#).

Suffix:

<m> 1..3
Event in a trigger sequence: 1 = A-event only

Parameters:

<Address> Numeric or string pattern, see [chapter 21.2.3.6, "Bit Pattern Parameter"](#), on page 667.

TRIGger<m>:I2C:ADDTo <AddressTo>

Sets the the end value of an address range if the condition is set to an address range with [TRIGger<m>:I2C:ACONdition](#).

Suffix:

<m> 1..3
Event in a trigger sequence: 1 = A-event only

Parameters:

<AddressTo> Numeric or string pattern, see [chapter 21.2.3.6, "Bit Pattern Parameter"](#), on page 667.

Usage:

Asynchronous command

TRIGger<m>:I2C:ADOR<n>:ENABLE <UseAddress>

Includes the indicated ADOR address in the "address OR" trigger condition.

Suffix:

<m> 1..3
Event in a trigger sequence: 1 = A-event only

<n> 1..4
Index of the address in an "address OR" condition (OR slot)

Parameters:

<UseAddress> ON | OFF
*RST: OFF

TRIGger<m>:I2C:ADOR<n>:ADRTYPE <AddressType>

Sets the address type for the indicated ADOR address in the "address OR" trigger condition.

Suffix:

<m> 1..3
Event in a trigger sequence: 1 = A-event only

<n> 1..4
Index of the address in an "address OR" condition (OR slot)

Parameters:

<AddressType> BIT7 | BIT7_RW | BIT10
*RST: BIT7

TRIGger<m>:I2C:ADOR<n>[:VALue] <Address>

Defines the address pattern of the indicated ADOR address in the "address OR" trigger condition.

Suffix:

<m> 1..3
Event in a trigger sequence: 1 = A-event only

<n> 1..4
Index of the address in an "address OR" condition (OR slot)

Parameters:

<Address> Numeric or string pattern, see [chapter 21.2.3.6, "Bit Pattern Parameter"](#), on page 667.

TRIGger<m>:I2C:ADOR<n>:RWBit <RWBit>

Defines the R/W bit of the indicated ADOR address in the "address OR" trigger condition.

Suffix:

<m> 1..3
Event in a trigger sequence: 1 = A-event only

<n> 1..4
Index of the address in an "address OR" condition (OR slot)

Parameters:

<RWBit> UNDEFINED | READ | WRITe | EITHER

UNDEFINED

Return value only

*RST: EITHER

TRIGger<m>:I2C:DPOPerator <DataPosiOperator>

Sets the operator for the data position. You can defined an exact position, or a position range.

Suffix:

<m> 1..3
Event in a trigger sequence: 1 = A-event only

Parameters:

<DataPosiOperator> ANY | EQUal | GETHan | RANGE

ANY

The position of the required pattern is not relevant.

EQUal | GETHan

Equal, Greater or equal than. These conditions require one data position to be set with [TRIGger<m>:I2C:DPOsition](#).

RANGE

In range: Set the minimum and maximum value of the range with [TRIGger<m>:I2C:DPOsition](#) and [TRIGger<m>:I2C:DPTO](#).

*RST: ANY

TRIGger<m>:I2C:DPOsition <DataPosition>

Sets the number of data bytes before the first byte of interest. These bytes are ignored.

Suffix:

<m> 1..3
Event in a trigger sequence: 1 = A-event only

Parameters:

<DataPosition> The index 0 is associated with the first data byte.
Range: 0 to 4095
Increment: 1
*RST: 0

TRIGger<m>:I2C:DPTO <DataPositionTo>

Defines the last byte of interest, if [TRIGger<m>:I2C:DPOperator](#) is set to RANGE.

Suffix:

<m> 1..3
Event in a trigger sequence: 1 = A-event only

Parameters:

<DataPositionTo> Range: 0 to 4095
Increment: 1
*RST: 0

TRIGger<m>:I2C:DCONDition <DataOperator>

Sets the operator to set a specific data value or a data range.

Suffix:

<m> 1..3
Event in a trigger sequence: 1 = A-event only

Parameters:

<DataOperator> EQUal | NEQual | LTHan | LETHan | GTHan | GETHan |
 INRange | OORange
 *RST: EQUal

TRIGger<m>:I2C:DMIN <DataPattern>

Specifies the data bit pattern, or sets the the start value of a data pattern range.. Enter the bytes in msb first bit order. The maximum pattern length is 64 bit. Waveform data is compared with the pattern byte-by-byte.

Suffix:

<m> 1..3
 Event in a trigger sequence: 1 = A-event only

Parameters:

<DataPattern> Numeric or string pattern, see [chapter 21.2.3.6, "Bit Pattern Parameter"](#), on page 667. The string parameter accepts the bit value X (don't care).

Usage: Asynchronous command

Firmware/Software: V 1.30

TRIGger<m>:I2C:DMAX <DataPattern>

Sets the the end value of an data range if [TRIGger<m>:I2C:DCONdition](#) is set to INRange or OORange.

Suffix:

<m> 1..3
 Event in a trigger sequence: 1 = A-event only

Parameters:

<DataPatternTo> Numeric or string pattern, see [chapter 21.2.3.6, "Bit Pattern Parameter"](#), on page 667. The string parameter accepts the bit value X (don't care).

Usage: Asynchronous command

Firmware/Software: V 1.30

Decoding Results (Option R&S RTO-K1)

BUS<m>:I2C:FRAMe<n>:DATA?	950
BUS<m>:I2C:FCOunt?	950
BUS<m>:I2C:FRAMe<n>:AACcess?	950
BUS<m>:I2C:FRAMe<n>:ACCess?	951
BUS<m>:I2C:FRAMe<n>:ACOMplete?	951
BUS<m>:I2C:FRAMe<n>:ADBStart?	951
BUS<m>:I2C:FRAMe<n>:ADDRess?	952
BUS<m>:I2C:FRAMe<n>:ADEVice?	952
BUS<m>:I2C:FRAMe<n>:AMODE?	952

BUS<m>:I2C:FRAMe<n>:AStart?	953
BUS<m>:I2C:FRAMe<n>:RWBStart?	953
BUS<m>:I2C:FRAMe<n>:STATus?	953
BUS<m>:I2C:FRAMe<n>:START?	954
BUS<m>:I2C:FRAMe<n>:STOP?	954
BUS<m>:I2C:FRAMe<n>:BCOunt?	955
BUS<m>:I2C:FRAMe<n>:BYTE<o>:ACCess?	955
BUS<m>:I2C:FRAMe<n>:BYTE<o>:ACKStart?	955
BUS<m>:I2C:FRAMe<n>:BYTE<o>:COMPLete?	956
BUS<m>:I2C:FRAMe<n>:BYTE<o>:START?	956
BUS<m>:I2C:FRAMe<n>:BYTE<o>:VALue?	957

BUS<m>:I2C:FRAMe<n>:DATA?

Returns the data words of the specified frame.

Suffix:

<m>	1..4	Selects the serial bus.
<n>	*	Selects the frame.

Return values:

<Data>	Comma-separated list of values. To set the value format, use FORMat:BPATtern .
--------	--

Usage: Query only

BUS<m>:I2C:FCOunt?

Returns the number of decoded frames.

Suffix:

<m>	1..4	Selects the serial bus.
-----	------	-------------------------

Return values:

<Count>	Total number of decoded frames.
---------	---------------------------------

Usage: Query only

BUS<m>:I2C:FRAMe<n>:AACCCess?

Returns the address acknowledge bit value for the indicated frame.

Suffix:

<m>	1..4	Selects the serial bus.
<n>	*	Selects the frame.

Return values:

<AddressAckBit> INComplete | ACK | NACK | EITHER
 *RST: INComplete

Usage: Query only

BUS<m>:I2C:FRAMe<n>:ACCess?

Returns the value of the R/W bit of the indicated frame.

Suffix:

<m> 1..4
 Selects the serial bus.
 <n> *
 Selects the frame.

Return values:

<RWBit> UNDEFINED | READ | WRITe | EITHER
 *RST: UNDEFINED

Usage: Query only

BUS<m>:I2C:FRAMe<n>:ACOMplete?

Returns if the address is completely contained in the acquisition.

Suffix:

<m> 1..4
 Selects the serial bus.
 <n> *
 Selects the frame.

Return values:

<AddressComplete> ON | OFF
 *RST: OFF

Usage: Query only

BUS<m>:I2C:FRAMe<n>:ADBStart?

Returns the start time of the address acknowledge bit.

Suffix:

<m> 1..4
 Selects the serial bus.
 <n> *
 Selects the frame.

Return values:

<AddressAckBitStart> Range: -100E+24 to 100E+24
 *RST: 0
 Default unit: s

Usage: Query only

BUS<m>:I2C:FRAMe<n>:ADDRess?

Returns the address value of the indicated frame *including* the R/W bit.

Suffix:

<m> 1..4
 Selects the serial bus.

<n> *
 Selects the frame.

Return values:

<AddressValue> To set the value format, use [FORMat:BPATtern](#).
 The values below – range, increment and default – are decimal values.
 Range: 0 to 2047
 *RST: 0

Usage: Query only

BUS<m>:I2C:FRAMe<n>:ADEVice?

Returns the pure device address of the indicated frame *without* the R/W bit.

Suffix:

<m> 1..4
 Selects the serial bus.

<n> *
 Selects the frame.

Return values:

<DevAddressValue> To set the value format, use [FORMat:BPATtern](#).
 The values below – range, increment and default – are decimal values.
 Range: 0 to 1023
 *RST: 0

Usage: Query only

BUS<m>:I2C:FRAMe<n>:AMODE?

Returns the address length.

Suffix:

<m> 1..4
Selects the serial bus.

<n> *
Selects the frame.

Return values:

<AddressType> BIT7 | BIT7_RW | BIT10 | AUTO | ANY
*RST: BIT7

Usage: Query only

BUS<m>:I2C:FRAMe<n>:ASStart?

Returns the start time of the address for the indicated frame.

Suffix:

<m> 1..4
Selects the serial bus.

<n> *
Selects the frame.

Return values:

<AddressStart> Range: -100E+24 to 100E+24
*RST: 0
Default unit: s

Usage: Query only

BUS<m>:I2C:FRAMe<n>:RWBStart?

Returns the start time of the R/W bit

Suffix:

<m> 1..4
Selects the serial bus.

<n> *
Selects the frame.

Return values:

<RWBitStart> Range: -100E+24 to 100E+24
*RST: 0
Default unit: s

Usage: Query only

BUS<m>:I2C:FRAMe<n>:STATus?

Returns the overall state of the frame.

Suffix:

<m> 1..4
Selects the serial bus.

<n> *
Selects the frame.

Return values:

<FrameState> INComplete | OK | UNEXpstop | INSufficient | ADDifferent

INComplete

The stop bit is missing.

OK

The frame is valid.

UNEXpstop

A stop bit was detected but clock and data are continued.

INSufficient

The frame is not completely contained in the acquisition. The acquired part of the frame is valid.

ADDifferent

Error in 10 bit address. In case of a read access on a 10 bit address, the first address byte is sent twice, first as write, the second as read. The first seven bits of the byte must be identical. If they are not identical, the ADDiffernt error is indicated.

*RST: OK

Usage: Query only

BUS<m>:I2C:FRAMe<n>:STARt?

Returns the start time of the specified frame.

Suffix:

<m> 1..4
Selects the serial bus.

<n> *
Selects the frame.

Return values:

<FrameStart> Range: -100E+24 to 100E+24

*RST: 0

Default unit: s

Usage: Query only

BUS<m>:I2C:FRAMe<n>:STOP?

Returns the end time of the specified frame.

Suffix:

<m>	1..4 Selects the serial bus.
<n>	* Selects the frame.

Return values:

<FrameStop>	Range: -100E+24 to 100E+24 *RST: 0 Default unit: s
-------------	--

Usage: Query only

BUS<m>:I2C:FRAMe<n>:BCOunt?

Returns the number of bytes in the specified frame

Suffix:

<m>	1..4 Selects the input channel.
<n>	* Selects the frame.

Return values:

<Count>	Byte count
---------	------------

Usage: Query only

BUS<m>:I2C:FRAMe<n>:BYTE<o>:ACCess?

Returns the acknowledge bit value of the specified data byte.

Suffix:

<m>	1..4 Selects the serial bus.
<n>	* Selects the frame.
<o>	* Selects the byte number.

Return values:

<ByteAckBit>	INComplete ACK NACK EITHER *RST: INComplete
--------------	--

Usage: Query only

BUS<m>:I2C:FRAMe<n>:BYTE<o>:ACKStart?

Returns the start time of the acknowledge bit of the specified byte.

Suffix:

<m>	1..4 Selects the serial bus.
<n>	* Selects the frame.
<o>	* Selects the byte number.

Return values:

<ByteAckBitStart>	To set the value format, use FORMat:BPATtern . The values below – range, increment and reset – are decimal values. Range: -100E+24 to 100E+24 *RST: 0 Default unit: s
-------------------	---

Usage: Query only

BUS<m>:I2C:FRAMe<n>:BYTE<o>:COMplete?

Returns if the indicated byte is completely contained in the acquisition.

Suffix:

<m>	1..4 Selects the serial bus.
<n>	* Selects the frame.
<o>	* Selects the byte number.

Return values:

<ByteComplete>	ON OFF *RST: OFF
----------------	-----------------------

Usage: Query only

BUS<m>:I2C:FRAMe<n>:BYTE<o>:STARt?

Returns the start time of the specified data byte.

Suffix:

<m>	1..4 Selects the serial bus.
<n>	* Selects the frame.
<o>	* Selects the byte number.

Return values:

<ByteStart> Range: -100E+24 to 100E+24
 *RST: 0
 Default unit: s

Usage: Query only

BUS<m>:I2C:FRAMe<n>:BYTE<o>:VALue?

Returns the data value of the specified byte.

Suffix:

<m> 1..4
 Selects the serial bus.

<n> *
 Selects the frame.

<o> *
 Selects the byte number.

Return values:

<ByteData> To set the value format, use [FORMat:BPATtern](#).
 The values below – range, increment and default – are decimal values.

Range: 0 to 255
 *RST: 0

Usage: Query only

Label List (Option R&S RTO-K1)

[BUS<m>:SYMBols](#)..... 957

[BUS<m>:I2C:FRAMe<n>:SYMBol?](#)..... 958

BUS<m>:SYMBols <UseTranslation>

Activates the lable list to be used for decoding.

Suffix:

<m> 1..4
 Selects the serial bus.

Parameters:

<UseTranslation> ON | OFF
 *RST: OFF

Usage: Asynchronous command

Firmware/Software: FW 1.36

BUS<m>:I2C:FRAMe<n>:SYMBol?

Returns the symbolic label of the specified frame if the label list is enabled.

Suffix:

<m>	1..4 Selects the serial bus.
<n>	* Selects the number of the frame in the current acquisition, 1...n.

Return values:

<Label> String with symbolic name of the address

Usage: Query only

Firmware/Software: FW 1.36

21.2.17.3 SPI

- [Configuration](#)..... 958
- [Trigger](#)..... 963
- [Decoding Results \(Option R&S RTO-K1\)](#)..... 966

Configuration

BUS<m>:SPI:BORDER	958
BUS<m>:SPI:WSIZE	959
BUS<m>:SPI:SCLK:SOURce	959
BUS<m>:SPI:SSElect:SOURce	959
BUS<m>:SPI:SSElect:POLarity	960
BUS<m>:SPI:MISO:SOURce	960
BUS<m>:SPI:MISO:POLarity	960
BUS<m>:SPI:MOSI:SOURce	961
BUS<m>:SPI:MOSI:POLarity	961
BUS<m>:SPI:TECHnology	961
BUS<m>:SPI:SCLK:THReshold	962
BUS<m>:SPI:MISO:THReshold	962
BUS<m>:SPI:MOSI:THReshold	962
BUS<m>:SPI:SSElect:THReshold	962
BUS<m>:SPI:FRCondition	962
BUS<m>:SPI:TIMeout	963

BUS<m>:SPI:BORDER <BitOrder>

Defines if the data of the messages starts with msb (most significant bit) or lsb (least significant bit).

Suffix:

<m>	1..4 Selects the serial bus.
-----	---------------------------------

Parameters:

<BitOrder> LSBF | MSBF
 *RST: MSBF

Usage: Asynchronous command

BUS<m>:SPI:WSize <WordLength>

Sets the number of bits in a message.

Suffix:

<m> 1..4
 Selects the serial bus.

Parameters:

<WordLength> Number of bits
 Range: 4 to 32
 Increment: 1
 *RST: 8

Usage: Asynchronous command

BUS<m>:SPI:SCLK:SOURce <SCLKsource>

Sets the input channel of the clock line.

Suffix:

<m> 1..4
 Selects the serial bus.

Parameters:

<SCLKsource> C1W1 | C2W1 | C3W1 | C4W1 | M1 | M2 | M3 | M4 | R1 | R2 |
 R3 | R4 | D0 | D1 | D2 | D3 | D4 | D5 | D6 | D7 | D8 | D9 | D10 |
 D11 | D12 | D13 | D14 | D15

Digital and analog channels cannot be used at the same time for data, clock and slave select lines.

See [chapter 21.2.3.2, "Waveform Parameter"](#), on page 666

*RST: C1W1

Usage: Asynchronous command

BUS<m>:SPI:SSElect:SOURce <SSsource>

Sets the input channel of the Slave Select line.

Suffix:

<m> 1..4
 Selects the serial bus.

Parameters:

<SSsource> NONE | C1W1 | C2W1 | C3W1 | C4W1 | M1 | M2 | M3 | M4 |
R1 | R2 | R3 | R4 | D0 | D1 | D2 | D3 | D4 | D5 | D6 | D7 | D8 |
D9 | D10 | D11 | D12 | D13 | D14 | D15

Digital and analog channels cannot be used at the same time for data, clock and slave select lines.

See [chapter 21.2.3.2, "Waveform Parameter"](#), on page 666

*RST: NONE

Usage:

Asynchronous command

BUS<m>:SPI:SSElect:POLarity <SSPolarity>

Selects whether transmitted slave select signal is high active (high = 1) or low active (low = 1).

Suffix:

<m> 1..4
Selects the serial bus.

Parameters:

<SSPolarity> ACTLow | ACTHigh
*RST: ACTLow

Usage:

Asynchronous command

BUS<m>:SPI:MISO:SOURce <MISOsource>

Sets the input channel of the MISO line.

Suffix:

<m> 1..4
Selects the serial bus.

Parameters:

<MISOsource> NONE | C1W1 | C2W1 | C3W1 | C4W1 | M1 | M2 | M3 | M4 |
R1 | R2 | R3 | R4 | D0 | D1 | D2 | D3 | D4 | D5 | D6 | D7 | D8 |
D9 | D10 | D11 | D12 | D13 | D14 | D15

Digital and analog channels cannot be used at the same time for data, clock and slave select lines.

See [chapter 21.2.3.2, "Waveform Parameter"](#), on page 666

*RST: NONE

Usage:

Asynchronous command

BUS<m>:SPI:MISO:POLarity <MISOPolarity>

Selects whether transmitted data is high active (high = 1) or low active (low = 1).

Suffix:

<m> 1..4
Selects the serial bus.

Parameters:

<MISOPolarity> ACTLow | ACTHigh
*RST: ACTHigh

Usage:

Asynchronous command

BUS<m>:SPI:MOSI:SOURce <MOSISource>

Sets the input channel of the MOSI line.

Suffix:

<m> 1..4
Selects the serial bus.

Parameters:

<MOSISource> NONE | C1W1 | C2W1 | C3W1 | C4W1 | M1 | M2 | M3 | M4 |
R1 | R2 | R3 | R4 | D0 | D1 | D2 | D3 | D4 | D5 | D6 | D7 | D8 |
D9 | D10 | D11 | D12 | D13 | D14 | D15

Digital and analog channels cannot be used at the same time for data, clock and slave select lines.

See [chapter 21.2.3.2, "Waveform Parameter"](#), on page 666

*RST: NONE

Usage:

Asynchronous command

BUS<m>:SPI:MOSI:POLarity <MOSIPolarity>

Selects whether transmitted data is high active (high = 1) or low active (low = 1).

Suffix:

<m> 1..4
Selects the serial bus.

Parameters:

<MOSIPolarity> ACTLow | ACTHigh
*RST: ACTHigh

Usage:

Asynchronous command

BUS<m>:SPI:TECHnology <Technology>

Sets the threshold voltage clock, slave select and data lines as defined for various signal technologies.

Suffix:

<m> 1..4
Selects the serial bus.

Parameters:

<Technology> V15 | V25 | V165 | V125 | V09 | VM13 | V38 | V20 | V0 | MAN

V15 | V25 | V165 | V125 | V09 | V38 | V20 | V0

1.5 V, 2.5 V, 1.65 V ... respectively

VM13

-1.3 V (negative value)

MAN

Manual setting of user-defined values with

BUS<m>:SPI:SCLK|SSEL|MISO|MOSI:THReshold.

*RST: V165

Usage:

SCPI confirmed

BUS<m>:SPI:SCLK:THReshold <SCLKThreshold>

BUS<m>:SPI:MISO:THReshold <MISOThreshold>

BUS<m>:SPI:MOSI:THReshold <MOSIThreshold>

BUS<m>:SPI:SSElect:THReshold <SSThreshold>

Set user-defined threshold values for the clock, MISO, MOSI and slave select lines.

Alternatively, you can set the thresholds according to the signal technology with

[BUS<m>:SPI:TECHnology](#).

Suffix:

<m> 1..4
Selects the serial bus.

Parameters:

<SSThreshold> User-defined value
Range: -12 to 12
Increment: 0.1
*RST: 0
Default unit: V

BUS<m>:SPI:FRCondition <FrameCondition>

Defines the start of a frame. A frame contains a number of successive words, at least one word.

Suffix:

<m> 1..4
Selects the serial bus.

Parameters:

<FrameCondition> SS | CLKTimeout

SS

Start and end of the frame is defined by the active state of the slave select signal, see [BUS<m>:SPI:SSElect:POLarity](#).

CLKTimeout

Defines a timeout on the clock line SCLK as limiter between two frames. The timeout condition is used for SPI connections without an SS line.

*RST: SS

BUS<m>:SPI:TIMEout <ClockTimeout>

Defines a timeout on the clock line SCLK as limiter between two frames. The timeout condition is used for SPI connections without an SS line.

Suffix:

<m> 1..4
Selects the serial bus.

Parameters:

<ClockTimeout> Range: 50E-9 to 10
Increment: 1E-6
*RST: 1E-3
Default unit: s

Trigger

TRIGger<m>:SPI:MODE	963
TRIGger<m>:SPI:PALignment	964
TRIGger<m>:SPI:DPOperator	964
TRIGger<m>:SPI:DPOStition	965
TRIGger<m>:SPI:DPTO	965
TRIGger<m>:SPI:FCONdition	965
TRIGger<m>:SPI:MISopattern	966
TRIGger<m>:SPI:MOSipattern	966

TRIGger<m>:SPI:MODE <Type>

Selects the trigger type for SPI analysis.

Suffix:

<m> 1..3
Event in a trigger sequence: 1 = A-event only

Parameters:

<Type>

SSActive | TIMEout | MOSI | MISO | MOMI

SSActive

Start of the message: slave select signal SS changes to the active state.

TIMEout

Triggers on the next message start after the "Timeout" time.

MOSI

Triggers on a specified data pattern in that is expected on the MOSI line. Define the pattern with `TRIGger<m>:SPI:MOSipattern`.

MISO

Triggers on a specified data pattern in that is expected on the MISO line. Define the pattern with `TRIGger<m>:SPI:MISOpattern`

MOMI

Triggers on a specified data patterns on the MISO and MOSI lines.

*RST: SSActive

Usage:

Asynchronous command

TRIGger<m>:SPI:PALignment <DataAlignment>

Defines how the specified data pattern is searched.

Suffix:

<m>

1..3

Event in a trigger sequence: 1 = A-event only

Parameters:

<DataAlignment>

WORD | BIT

WORD

The pattern is matched only at word boundaries.

BIT

Bit-by bit: the pattern can be at any position in the data word.

*RST: WORD

Usage:

Asynchronous command

TRIGger<m>:SPI:DPOperator <DataPosiOperator>

Sets the operator for the data position. You can defined an exact position, or a position range.

Suffix:

<m>

1..3

Event in a trigger sequence: 1 = A-event only

Parameters:

<DataPosiOperator> ANY | EQUal | NEQual | GETHan | INRange

ANY

The position of the required pattern is not relevant.

EQUal | NEQual | GETHan

Equal, Not equal, Greater or equal than. These conditions require one data position to be set with `TRIGger<m>:SPI:DPOStion`.

INRange

Set the minimum and maximum value of the range with `TRIGger<m>:SPI:DPOStion` and `TRIGger<m>:SPI:DPTO`.

*RST: ANY

TRIGger<m>:SPI:DPOStion <DataPosition>

Sets the number of bits or words to be ignored before the first bit or word of interest. The effect is defined by `TRIGger<m>:SPI:PALignment`.

Suffix:

<m> 1..3
Event in a trigger sequence: 1 = A-event only

Parameters:

<DataPosition> The index 0 is associated with the first data byte.
Range: 0 to 4095 for triggering on one line (MISO or MOSI), 2047 for triggering on both lines.
Increment: 1
*RST: 0

TRIGger<m>:SPI:DPTO <DataPositionTo>

Defines the last bit or word of interest, if `TRIGger<m>:SPI:DPOPerator` is set to `INRange`.

Suffix:

<m> 1..3
Event in a trigger sequence: 1 = A-event only

Parameters:

<DataPositionTo> Range: 0 to 4095 for triggering on one line (MISO or MOSI), 2047 for triggering on both lines.
Increment: 1
*RST: 0

TRIGger<m>:SPI:FCONdition <DataOperator>

Selects the operator for the MISO and MOSI pattern.

Suffix:
 <m> 1..3
 Event in a trigger sequence: 1 = A-event only

Parameters:
 <DataOperator> EQUal | NEQual
 *RST: EQUal

Firmware/Software: V 1.25

TRIGger<m>:SPI:MISOpattern <MISOPattern>

Specifies the pattern to be triggered on the MOSI line.

Suffix:
 <m> 1..3
 Event in a trigger sequence: 1 = A-event only

Parameters:
 <MISOPattern> Numeric or string pattern, see [chapter 21.2.3.6, "Bit Pattern Parameter"](#), on page 667. The string parameter accepts the bit value X (don't care).

Usage: Asynchronous command

TRIGger<m>:SPI:MOSIpattern <MOSIPattern>

Specifies the pattern to be triggered on the MOSI line.

Suffix:
 <m> 1..3
 Event in a trigger sequence: 1 = A-event only

Parameters:
 <MOSIPattern> Numeric or string pattern, see [chapter 21.2.3.6, "Bit Pattern Parameter"](#), on page 667. The string parameter accepts the bit value X (don't care).

Usage: Asynchronous command

Decoding Results (Option R&S RTO-K1)

BUS<m>:SPI:FRAME<n>:DATA?	967
BUS<m>:SPI:FCOunt?	967
BUS<m>:SPI:FRAME<n>:STATus?	967
BUS<m>:SPI:FRAME<n>:START?	968
BUS<m>:SPI:FRAME<n>:STOP?	968
BUS<m>:SPI:FRAME<n>:WCOunt?	969
BUS<m>:SPI:FRAME<n>:WORD<o>:START?	969
BUS<m>:SPI:FRAME<n>:WORD<o>:STOP?	969
BUS<m>:SPI:FRAME<n>:WORD<o>:MISO?	970
BUS<m>:SPI:FRAME<n>:WORD<o>:MOSI?	970

BUS<m>:SPI:FRAME<n>:DATA?

Returns the data words of the specified frame.

Suffix:

<m>	1..4 Selects the serial bus.
<n>	* Selects the frame.

Parameters:

<Data>	Comma-separated list of data words. To set the value format, use FORMat:BPATtern .
--------	--

Usage:	Query only Asynchronous command
---------------	------------------------------------

BUS<m>:SPI:FCOunt?

Returns the number of decoded frames.

Suffix:

<m>	1..4 Selects the serial bus.
-----	---------------------------------

Return values:

<Count>	Total number of decoded frames.
---------	---------------------------------

Usage:	Query only
---------------	------------

Firmware/Software:	V 1.27
---------------------------	--------

BUS<m>:SPI:FRAME<n>:STATus?

Returns the overall state of the specified frame.

Suffix:

<m>	1..4 Selects the serial bus.
<n>	* Selects the frame.

Return values:

<FrameState> OK | VOID | INCFirst | INCLast | INSufficient
 OK: the frame is valid.
 VOID: the frame is empty.
 INCFirst: INComplete First word. The first word does not have the expected word length.
 INCLast: INComplete Last word. The last word does not have the expected word length.
 INSufficient: The frame is not completely contained in the acquisition. The acquired part of the frame is valid.
 *RST: OK

Usage: Query only

BUS<m>:SPI:FRAMe<n>:START?

Returns the start time of the specified frame.

Suffix:

<m> 1..4
 Selects the serial bus.
 <n> *
 Selects the frame.

Return values:

<FrameStart> Range: -100E+24 to 100E+24
 *RST: 0
 Default unit: s

Usage: Query only

BUS<m>:SPI:FRAMe<n>:STOP?

Returns the end time of the specified frame.

Suffix:

<m> 1..4
 Selects the serial bus.
 <n> *
 Selects the frame.

Return values:

<FrameStop> Range: -100E+24 to 100E+24
 *RST: 0
 Default unit: s

Usage: Query only

BUS<m>:SPI:FRAME<n>:WCOunt?

Returns the number of words in the specified frame.

Suffix:

<m> 1..4
Selects the serial bus.

<n> *
Selects the frame.

Return values:

<WordCount> Range: 0 to 4096
*RST: 0

Usage: Query only

Firmware/Software: V 1.27

BUS<m>:SPI:FRAME<n>:WORD<o>:START?

Returns the start time of the specified data word.

Suffix:

<m> 1..4
Selects the serial bus.

<n> *
Selects the frame.

<o> *
Selects the word number.

Return values:

<WordStart> Range: -100E+24 to 100E+24
*RST: 0
Default unit: s

Usage: Query only

BUS<m>:SPI:FRAME<n>:WORD<o>:STOP?

Returns the end time of the specified data word.

Suffix:

<m> 1..4
Selects the serial bus.

<n> *
Selects the frame.

<o> *
Selects the word number.

Return values:

<WordStop> Range: -100E+24 to 100E+24
 *RST: 0
 Default unit: s

Usage: Query only

BUS<m>:SPI:FRAME<n>:WORD<o>:MISO?

Returns the data value of the specified word on the MISO line.

Suffix:

<m> 1..4
 Selects the serial bus.

<n> *
 Selects the frame.

<o> *
 Selects the word number.

Return values:

<MISOValue> To set the value format, use [FORMat:BPATtern](#).
 The values below – range, increment and reset – are decimal values.

Range: 0 to 4294967295
 *RST: 0

Usage: Query only

BUS<m>:SPI:FRAME<n>:WORD<o>:MOSI?

Returns the data value of the specified word on the MOSI line.

Suffix:

<m> 1..4
 Selects the serial bus.

<n> *
 Selects the frame.

<o> *
 Selects the word number.

Return values:

<MOSIValue> To set the value format, use [FORMat:BPATtern](#).
 The values below – range, increment and reset – are decimal values.

Range: 0 to 4294967295
 *RST: 0

Usage: Query only

21.2.17.4 UART

- [UART Configuration](#)..... 971
- [UART Trigger](#)..... 975
- [Decoding Results \(Option R&S RTO-K1\)](#)..... 978

UART Configuration

BUS<m>:UART:RX:SOURce	971
BUS<m>:UART:TX:SOURce	971
BUS<m>:UART:RX:THReshold	972
BUS<m>:UART:TX:THReshold	972
BUS<m>:UART:TECHnology	972
BUS<m>:UART:BITRate	973
BUS<m>:UART:BAUDrate	973
BUS<m>:UART:PARity	973
BUS<m>:UART:BITime	974
BUS<m>:UART:POLarity	974
BUS<m>:UART:SBIT	974
BUS<m>:UART:SSIZe	975

BUS<m>:UART:RX:SOURce <RxSource>

Selects the input channel for the receiver signal.

Suffix:

<m> 1..4
Selects the serial bus.

Parameters:

<RxSource> NONE | C1W1 | C2W1 | C3W1 | C4W1 | M1 | M2 | M3 | M4 |
R1 | R2 | R3 | R4 | D0 | D1 | D2 | D3 | D4 | D5 | D6 | D7 | D8 |
D9 | D10 | D11 | D12 | D13 | D14 | D15

Digital and analog channels cannot be used at the same time for RX and TX lines.

See [chapter 21.2.3.2, "Waveform Parameter"](#), on page 666

*RST: NONE

Usage: Asynchronous command

BUS<m>:UART:TX:SOURce <TxSource>

Selects the input channel for the transmitter signal.

Suffix:

<m> 1..4
Selects the serial bus.

Parameters:

<TxSource> NONE | C1W1 | C2W1 | C3W1 | C4W1 | M1 | M2 | M3 | M4 |
R1 | R2 | R3 | R4 | D0 | D1 | D2 | D3 | D4 | D5 | D6 | D7 | D8 |
D9 | D10 | D11 | D12 | D13 | D14 | D15

Digital and analog channels cannot be used at the same time for RX and TX lines.

See [chapter 21.2.3.2, "Waveform Parameter"](#), on page 666

*RST: NONE

Usage:

Asynchronous command

BUS<m>:UART:RX:THReshold <RxThreshold>

Sets a user-defined threshold value for the Rx line.

Alternatively, you can set the threshold according to the signal technology with [BUS<m>:UART:TECHnology](#).

Suffix:

<m> 1..4
Selects the serial bus.

Parameters:

<RxThreshold> User-defined clock threshold
Range: -12 to 12
Increment: 0.1
*RST: 0
Default unit: V

BUS<m>:UART:TX:THReshold <TxThreshold>

Sets a user-defined threshold value for the Tx line.

Alternatively, you can set the threshold according to the signal technology with [BUS<m>:UART:TECHnology](#).

Suffix:

<m> 1..4
Selects the serial bus.

Parameters:

<TxThreshold> User-defined clock threshold
Range: -12 to 12
Increment: 0.1
*RST: 0
Default unit: V

BUS<m>:UART:TECHnology <Technology>

Sets the threshold voltage Tx and Rx lines as defined for various signal technologies.

Suffix:

<m> 1..4
Selects the serial bus.

Parameters:

<Technology> V15 | V25 | V165 | V125 | V09 | VM13 | V38 | V20 | V0 | MAN

V15 | V25 | V165 | V125 | V09 | V38 | V20 | V0

1.5 V, 2.5 V, 1.65 V ... respectively

VM13

-1.3 V (negative value)

MAN

Manual setting of user-defined values with [BUS<m>:UART:RX:THReshold](#) and [BUS<m>:UART:TX:THReshold](#).

*RST: V165

Usage: SCPI confirmed

BUS<m>:UART:BITRate <Bitrate>

Sets the number of transmitted bits per second.

Suffix:

<m> 1..4

Parameters:

<Bitrate> Range: 300 to 20000000
Increment: 1
*RST: 9600
Default unit: bps

Usage: Asynchronous command

BUS<m>:UART:BAUDrate <Bitrate>

Same as [BUS<m>:UART:BITRate](#).

Suffix:

<m> 1..4

Parameters:

<Bitrate> Range: 300 to 20000000
Increment: 1
*RST: 9600
Default unit: bps

Usage: Asynchronous command

BUS<m>:UART:PARity <Parity>

Defines the optional parity bit that is used for error detection.

See also: "[Parity](#)" on page 451.

Suffix:
 <m> 1..4
 Selects the serial bus.

Parameters:
 <Parity> NONE | ODD | EVEN | MARK | SPC | DC

MARK
 The parity bit is always a logic 1.

SPC
 SPaCe: The parity bit is always a logic 0.

DC
 Don't Care: the parity is ignored.

*RST: NONE

Usage: Asynchronous command

BUS<m>:UART:BITime <InterframeTime>

Defines a timeout between a stop bit and the next start bit. The frame start is the first start bit after the interframe time.

Suffix:
 <m> 1..4
 Selects the serial bus.

Parameters:
 <InterframeTime> Range: 1E-6 to 1
 Increment: 1
 *RST: 1E-3
 Default unit: s

Usage: Asynchronous command

BUS<m>:UART:POLarity <Polarity>

Defines the idle state of the bus. The idle state corresponds to a logic 1. The transmitted data on the bus is high (high = 1) or low (low = 1) active.

Suffix:
 <m> 1..4
 Selects the serial bus.

Parameters:
 <Polarity> IDLLow | IDLHigh
 *RST: IDLHigh

Usage: Asynchronous command

BUS<m>:UART:SBIT <StopBits>

Sets the number of stop bits: 1; 1.5 or 2 stop bits are possible.

Suffix:

<m> 1..4
Selects the serial bus.

Parameters:

<StopBits> B1 | B15 | B2
*RST: B1

Usage:

Asynchronous command

BUS<m>:UART:SSize <DataBits>

Sets the number of data bits in a message.

Suffix:

<m> 1..4
Selects the serial bus.

Parameters:

<DataBits> Number of data bits
Range: 5 to 8
Increment: 1
*RST: 8

Usage:

Asynchronous command

UART Trigger

TRIGger<m>:UART:TYPE.....	975
TRIGger<m>:UART:SOURce.....	976
TRIGger<m>:UART:DPOPerator.....	976
TRIGger<m>:UART:DPOStion.....	976
TRIGger<m>:UART:DPTO.....	977
TRIGger<m>:UART:FCONdition.....	977
TRIGger<m>:UART:DATA.....	977

TRIGger<m>:UART:TYPE <Type>

Selects the trigger type for UART analysis.

See also: "Type" on page 453

Suffix:

<m> 1..3
Event in a trigger sequence: 1 = A-event only

Parameters:

<Type> STBT | PCKS | DATA | PRER | BRKC | STPerror
 STBT: Start bit
 PCKS: Packet start
 DATA: Serial pattern
 PRER: Parity error
 BRKC: Break condition
 STPerror: Stop error
 *RST: STBT

Usage: Asynchronous command

TRIGger<m>:UART:SOURce <Source>

Selects the transmitter or receiver line as trigger source.

Suffix:

<m> 1..3
 Event in a trigger sequence: 1 = A-event only

Parameters:

<Source> TX | RX
 *RST: TX

Usage: Asynchronous command

TRIGger<m>:UART:DPOPerator <DataPosiOperator>

Sets the operator for the data position. You can defined an exact position, or a position range.

Suffix:

<m> 1..3
 Event in a trigger sequence: 1 = A-event only

Parameters:

<DataPosiOperator> EQUal | NEQual | GETHan | INRange
 *RST: GETHan

Usage: Asynchronous command

TRIGger<m>:UART:DPOStition <DataPosition>

Sets the number of words before the first word of interest. These offset words are ignored.

Suffix:

<m> 1..3
 Event in a trigger sequence: 1 = A-event only

Parameters:

<DataPosition> Number of words
 Range: 0 to 32767
 Increment: 1
 *RST: 0

Usage: Asynchronous command

TRIGger<m>:UART:DPTO <DataPositionTo>

Defines the last word of interest, if [TRIGger<m>:UART:DPOperator](#) defines a position range.

Suffix:

<m> 1..3
 Event in a trigger sequence: 1 = A-event only

Parameters:

<DataPositionTo> Range: 0 to 32767
 Increment: 1
 *RST: 0

Usage: Asynchronous command

TRIGger<m>:UART:FCONdition <DataOperator>

Selects the operator for the data pattern ([TRIGger<m>:UART:DATA](#)).

Suffix:

<m> 1..3
 Event in a trigger sequence: 1 = A-event only

Parameters:

<DataOperator> EQUal | NEQual
 *RST: EQUal

TRIGger<m>:UART:DATA <Data>

Specifies the data pattern to be found on the specified trigger source, in binary or hex format. Enter the words in msb first bit order.

Suffix:

<m> 1..3
 Event in a trigger sequence: 1 = A-event only

Parameters:

<Data> Numeric or string pattern, see [chapter 21.2.3.6, "Bit Pattern Parameter"](#), on page 667. The string parameter accepts the bit value X (don't care).

Usage: Asynchronous command

Decoding Results (Option R&S RTO-K1)

BUS<m>:UART:WORD<n>:RXValue?	978
BUS<m>:UART:WORD<n>:TXValue?	978
BUS<m>:UART:WORD<n>:COUNT?	978
BUS<m>:UART:WORD<n>:SOURce?	978
BUS<m>:UART:WORD<n>:START?	979
BUS<m>:UART:WORD<n>:STATe?	979

BUS<m>:UART:WORD<n>:RXValue?**BUS<m>:UART:WORD<n>:TXValue?**

Returns the value of the specified word on the Rx line or Tx line, respectively.

Suffix:

<m>	1..4 Selects the serial bus.
<n>	* Selects the word.

Return values:

<RxValue>	To set the value format, use FORMat:BPATtern .
<TxValue>	The values below – range, increment and reset – are decimal values.
	Range: 0 to 255
	*RST: 0

Usage: Query only

BUS<m>:UART:WORD<n>:COUNT?

Returns the number of words in the acquisition.

Suffix:

<m>	1..4 Selects the serial bus.
<n>	* The suffix is irrelevant.

Return values:

<Count>	Number of words
---------	-----------------

Usage: Query only

BUS<m>:UART:WORD<n>:SOURce?

Returns the line on which the specified word was transferred.

Suffix:

<m>	1..4 Selects the serial bus.
-----	---------------------------------

<n> *
Selects the word.

Return values:

<WordSource> TX | RX
*RST: TX

Usage: Query only

BUS<m>:UART:WORD<n>:START?

Returns the start time of the specified word.

Suffix:

<m> 1..4
Selects the serial bus.

<n> *
Selects the word.

Return values:

<WordStart> Range: -100E+24 to 100E+24
*RST: 0
Default unit: s

Usage: Query only

BUS<m>:UART:WORD<n>:STATE?

Returns the status of the specified word.

Suffix:

<m> 1..4
Selects the serial bus.

<n> *
Selects the word.

Return values:

<WordState> OK | FRStArT | FREnD | FRME | BREak | STERror | SPERror |
PRERror | INSufficient
OK: the frame is valid.
BREak: stop bit error with 0x00 word
STERror: StarT ERror, incorrect start bit
SPERror: StoP ERror, incorrect stop bit
PRERror: PaRity ERror, incorrect parity bit.
INSufficient: The frame is not completely contained in the acquisition. The acquired part of the frame is valid.
*RST: OK

Usage: Query only

21.2.17.5 CAN (Option R&S RTO-K3)

• CAN Configuration.....	980
• CAN Trigger.....	983
• CAN Decoding Results.....	989
• Label List.....	995

CAN Configuration

BUS<m>:CAN:DATA:SOURce.....	980
BUS<m>:CAN:TYPE.....	980
BUS<m>:CAN:DATA:THReshold.....	980
BUS<m>:CAN:TECHnology.....	981
BUS<m>:CAN:BITRate.....	981
BUS<m>:CAN:SAMPlepoint.....	982
BUS<m>:CAN:T1Segment.....	982
BUS<m>:CAN:T2Segment.....	982
BUS<m>:CAN:JWIDth.....	982

BUS<m>:CAN:DATA:SOURce <DataSource>

Sets the source of the data line that is selected with `BUS<m>:CAN:TYPE`.

Suffix:

<m> 1..4
Selects the serial bus.

Parameters:

<DataSource> C1W1 | C2W1 | C3W1 | C4W1 | M1 | M2 | M3 | M4 | R1 | R2 |
R3 | R4 | D0 | D1 | D2 | D3 | D4 | D5 | D6 | D7 | D8 | D9 | D10 |
D11 | D12 | D13 | D14 | D15
*RST: C1W1

Usage: Asynchronous command

BUS<m>:CAN:TYPE <SignalType>

Selects the CAN-High or CAN-Low line. Both lines are required for differential signal transmission used by CAN.

Suffix:

<m> 1..4
Selects the serial bus.

Parameters:

<SignalType> CANH | CANL
*RST: CANL

BUS<m>:CAN:DATA:THReshold <Threshold>

Sets a user-defined threshold value.

Alternatively, you can set the threshold according to the signal technology with [BUS<m>:CAN:TECHnology](#).

Suffix:

<m> 1..4
Selects the serial bus.

Parameters:

<Threshold> Range: -12 to 12
Increment: 0.1
*RST: 0
Default unit: V

BUS<m>:CAN:TECHnology <Technology>

Sets the threshold voltage as defined for various signal technologies.

Suffix:

<m> 1..4
Selects the serial bus.

Parameters:

<Technology> V25 | V3 | V2 | V0 | MAN
V25
2.5 Volt (CMOS 5.0 V)
V3
3.0 Volt (CAN_H HS / CAN_L LS)
V2
2.0 Volt (CAN_L HS / CAN_H LS)
V0
Ground
MAN
Manual setting of user-defined values with [BUS<m>:CAN:DATA:THReshold](#).
*RST: V25

BUS<m>:CAN:BITRate <Bitrate>

Sets the number of transmitted bits per second.

Suffix:

<m> 1..4
Selects the serial bus.

Parameters:

<Bitrate> Range: 100 to 5000000
Increment: 1
*RST: 100000
Default unit: bps

BUS<m>:CAN:SAMPlEpoint <SamplePoint>

Sets the position of the sample point within the bit in percent of the nominal bit time.

Alternatively, you can set the sample point with [BUS<m>:CAN:T1Segment](#) and [BUS<m>:CAN:T2Segment](#).

Suffix:

<m> 1..4
Selects the serial bus.

Parameters:

<SamplePoint> Range: 10 to 90
Increment: 5
*RST: 50
Default unit: %

BUS<m>:CAN:T1Segment <TimeSeg1>**BUS<m>:CAN:T2Segment** <TimeSeg2>

Set the number of time quanta before the sample point (T1Segment) and after the sample point (T2Segment). T1Segment comprises the segments Synch_seg, Prop_seg, and Phase_seg1 which are specified in the CAN standard. T2Segment matches Phase_seg2 specified in the CAN standard.

Make sure to set both values for correct definition of the sample point. Alternatively, you can use [BUS<m>:CAN:SAMPlEpoint](#).

See also: "[Synchronization: Sample point, Time segments, Jump width](#)" on page 458

Suffix:

<m> 1..4
Selects the serial bus.

Parameters:

<TimeSeg2> Time quanta
Range: 1 to 25
Increment: 1
*RST: 5

BUS<m>:CAN:JWIDth <JumpWidth>

Defines the maximum number of time quanta for phase correction. Time segment1 may be lengthened or Time segment2 may be shortened due to resynchronization. Resynchronization corrects the phase error of an edge caused by the drift of the oscillators.

Suffix:

<m> 1..4
Selects the serial bus.

Parameters:

<JumpWidth>	Time quanta
	Range: 1 to 25
	Increment: 1
	*RST: 1

CAN Trigger

TRIGger<m>:CAN:TYPE.....	983
TRIGger<m>:CAN:FTYPE.....	984
TRIGger<m>:CAN:ITYPe.....	985
TRIGger<m>:CAN:ICONdition.....	985
TRIGger<m>:CAN:IMIN.....	986
TRIGger<m>:CAN:IMAX.....	986
TRIGger<m>:CAN:DCONdition.....	986
TRIGger<m>:CAN:DMIN.....	986
TRIGger<m>:CAN:DMAX.....	987
TRIGger<m>:CAN:BORDER.....	987
TRIGger<m>:CAN:DLCCONdition.....	987
TRIGger<m>:CAN:DLC.....	988
TRIGger<m>:CAN:ACKerror.....	988
TRIGger<m>:CAN:BITSterror.....	988
TRIGger<m>:CAN:CRCError.....	989
TRIGger<m>:CAN:FORMerror.....	989

TRIGger<m>:CAN:TYPE <Type>

Selects the trigger type for LIN analysis.

See: "[Trigger type](#)" on page 460.

Suffix:

<m>	1..3
	Event in a trigger sequence: 1 = A-event only

Parameters:

<Type>

STOF | FTYP | ID | IDDT | ERRC

STOF

STart Of Frame: triggers on the first edge of the dominant SOF bit (synchronization bit).

FTYP

Frame TYPE: triggers on a specified frame type (data, remote, error, or overload) and on the identifier format.

To set the frame type, use `TRIGger<m>:CAN:FTYPE`. Set the identifier format with `TRIGger<m>:CAN:ITYPe`

ID

IDentifier: Sets the trigger to one specific identifier or an identifier range. To set the identifier, use `TRIGger<m>:CAN:ICONdition`, `TRIGger<m>:CAN:IMIN`, and `TRIGger<m>:CAN:IMAX`.

IDDT

IDentifier and DaTa: Combination of identifier and data conditions To set the identifier condition, use `TRIGger<m>:CAN:ICONdition`, `TRIGger<m>:CAN:IMIN`, and `TRIGger<m>:CAN:IMAX`.

To set the data condition, use `TRIGger<m>:CAN:DCondition`, `TRIGger<m>:CAN:DMIN`, and `TRIGger<m>:CAN:DMAX`.

ERRC

ERRor Condition: Define the error types with `TRIGger<m>:CAN:ACKerror`, `TRIGger<m>:CAN:BITSterror`, `TRIGger<m>:CAN:CRCError`, and `TRIGger<m>:CAN:FORMerror`.

*RST: STOF

TRIGger<m>:CAN:FTYPE <FrameType>

Selects the CAN frame type if `TRIGger<m>:CAN:TYPE` is set to FTYP (frame type) or ID (identifier).

For data and remote frames, the identifier format has to be set with `TRIGger<m>:CAN:ITYPe`.

See also: "Frame type" on page 461

Suffix:

<m>

1..3

Event in a trigger sequence: 1 = A-event only

Parameters:

<FrameType> ANY | DATA | REMote | ERRor | OVERload
 Available values depend on the [TRIGger<m>:CAN:TYPE](#) setting:
 If the trigger type is set to FTYP (frame type), you can set the values DATA | REMote | ERRor | OVERload.
 If the trigger type is set to ID (identifier), you can set the values ANY | DATA | REMote.
 *RST: ANY

TRIGger<m>:CAN:ITYPE <IdentifierType>

Selects the format of data and remote frames.

Suffix:

<m> 1..3
 Event in a trigger sequence: 1 = A-event only

Parameters:

<IdentifierType> ANY | B11 | B29
B11
 11 bit identifier (standard format). The instrument triggers on the sample point of the IDE bit.
B29
 29 bit identifier (extended format). The instrument triggers on the sample point of the RTR bit.
 *RST: ANY

TRIGger<m>:CAN:ICONdition <IdentifierOperator>

Sets the operator to set a specific identifier or an identifier range.

Suffix:

<m> 1..3
 Event in a trigger sequence: 1 = A-event only

Parameters:

<IdentifierOperator> EQUal | NEQual | LTHan | LETHan | GTHan | GETHan | INRange | OORange
EQUal | NEQual | LTHan | LETHan | GTHan | GETHan
 Equal, Not equal, Less than, Less or equal than, Greater Than, Greater or equal than. These condition require one identifier pattern to be set with [TRIGger<m>:CAN:IMIN](#).
INRange | OORange
 In range / Out of range: Set the minimum and maximum value of the range with [TRIGger<m>:CAN:IMIN](#) and [TRIGger<m>:CAN:IMAX](#) on page 986.
 *RST: EQUal

TRIGger<m>:CAN:IMIN <IdPattern>

Specifies a message identifier pattern, or sets the the start value of an identifier range.

Suffix:

<m> 1..3
Event in a trigger sequence: 1 = A-event only

Parameters:

<IdPattern> Numeric or string pattern, see [chapter 21.2.3.6, "Bit Pattern Parameter"](#), on page 667.

TRIGger<m>:CAN:IMAX <IdPatternTo>

Sets the the end value of an identifier range if [TRIGger<m>:CAN:ICONdition](#) is set to [INRange](#) or [OORange](#).

Suffix:

<m> 1..3
Event in a trigger sequence: 1 = A-event only

Parameters:

<IdPatternTo> Numeric or string pattern, see [chapter 21.2.3.6, "Bit Pattern Parameter"](#), on page 667.

TRIGger<m>:CAN:DCondition <DataOperator>

Sets the operator to set a specific data pattern or a data pattern range.

Suffix:

<m> 1..3
Event in a trigger sequence: 1 = A-event only

Parameters:

<DataOperator> [EQUal](#) | [NEQUal](#) | [LTHan](#) | [LETHan](#) | [GTHan](#) | [GETHan](#) | [INRange](#) | [OORange](#)
[EQUal](#) | [NEQUal](#) | [LTHan](#) | [LETHan](#) | [GTHan](#) | [GETHan](#)
Equal, Not equal, Less than, Less or equal than, Greater Than, Greater or equal than. These conditions require one data pattern to be set with [TRIGger<m>:CAN:DMIN](#).
[INRange](#) | [OORange](#)
In range / Out of range: Set the minimum and maximum value of the range with [TRIGger<m>:CAN:DMIN](#) and [TRIGger<m>:CAN:DMAX](#).
*RST: [EQUal](#)

TRIGger<m>:CAN:DMIN <DataPattern>

Specifies a data pattern, or sets the the start value of a data pattern range.

Suffix:

<m> 1..3
Event in a trigger sequence: 1 = A-event only

Parameters:

<DataPattern> Numeric or string pattern, see [chapter 21.2.3.6, "Bit Pattern Parameter"](#), on page 667. The string parameter accepts the bit value X (don't care).

TRIGger<m>:CAN:DMAX <DataPatternTo>

Sets the the end value of an data range if [TRIGger<m>:CAN:DCONdition](#) is set to [INRange](#) or [OORange](#).

Suffix:

<m> 1..3
Event in a trigger sequence: 1 = A-event only

Parameters:

<DataPatternTo> Numeric or string pattern, see [chapter 21.2.3.6, "Bit Pattern Parameter"](#), on page 667. The string parameter accepts the bit value X (don't care).

TRIGger<m>:CAN:BORDER <Endianness>

Sets the byte order (endianness) of the data transfer.

Suffix:

<m> 1..3
Event in a trigger sequence: 1 = A-event only

Parameters:

<Endianness> BENDian | LENDian
BENDian
Big endian, most significant byte first.
LENDian
Little endian, least significant byte first.
*RST: BENDian

TRIGger<m>:CAN:DLCCONdition <DLCOperator>

Operator to set the data length code for triggering on CAN data. For big endian transfer direction, you can trigger on a number of bytes less than the DLC of the frame, that means, on the beginning of the data pattern. For little endian transfer direction, the exact number of data bytes in the frame must be set. The number of data bytes to be found is set with [TRIGger<m>:CAN:DLC](#) on page 988.

Example: $DLC \geq 2$. The frame has at least two bytes, and you trigger on the data of the first two bytes.

See also: [TRIGger<m>:CAN:BORDER](#) on page 987.

Suffix:

<m> 1..3
Event in a trigger sequence: 1 = A-event only

Parameters:

<DLCOperator> EQUal | GETHan
For little endian transfer direction, EQUal must be set.
*RST: GETHan

TRIGger<m>:CAN:DLC <WordCount>

Sets the Data Length Code, the number of data bytes to be found. For complete definition, set also the operator with [TRIGger<m>:CAN:DLCCondition](#) on page 987.

Suffix:

<m> 1..3
Event in a trigger sequence: 1 = A-event only

Parameters:

<WordCount> Range: 1 to 8
Increment: 1
*RST: 1

TRIGger<m>:CAN:ACKerror <AckError>

Triggers when the transmitter does not receive an acknowledgment - a dominant bit during the Ack Slot.

The trigger type has to be set before: [TRIGger<m>:CAN:TYPE](#) to ERRc.

Suffix:

<m> 1..3
Event in a trigger sequence: 1 = A-event only

Parameters:

<AckError> ON | OFF
*RST: ON

TRIGger<m>:CAN:BITSterror <BitStuffingError>

Triggers if a stuff error occurs - when the 6th consecutive equal bit level in the mentioned fields is detected.

The trigger type has to be set before: [TRIGger<m>:CAN:TYPE](#) to ERRc.

Suffix:

<m> 1..3
Event in a trigger sequence: 1 = A-event only

Parameters:

<BitStuffingError> ON | OFF
*RST: ON

TRIGger<m>:CAN:CRCError <ChecksumError>

Triggers on CRC errors. A CRC error occurs when the CRC calculated by the receiver differs from the received value in the CRC sequence.

The trigger type has to be set before: **TRIGger<m>:CAN:TYPE** to **ERRC**.

Suffix:

<m> 1..3
Event in a trigger sequence: 1 = A-event only

Parameters:

<ChecksumError> ON | OFF
*RST: ON

TRIGger<m>:CAN:FORMError <FormError>

Triggers when a fixed-form bit field contains one or more illegal bits.

The trigger type has to be set before: **TRIGger<m>:CAN:TYPE** to **ERRC**.

Suffix:

<m> 1..3
Event in a trigger sequence: 1 = A-event only

Parameters:

<FormError> ON | OFF
*RST: ON

CAN Decoding Results

BUS<m>:CAN:FCOut?	990
BUS<m>:CAN:FRAMe<n>:STATus?	990
BUS<m>:CAN:FRAMe<n>:STARt?	990
BUS<m>:CAN:FRAMe<n>:STOP?	990
BUS<m>:CAN:FRAMe<n>:TYPE?	991
BUS<m>:CAN:FRAMe<n>:DATA?	991
BUS<m>:CAN:FRAMe<n>:ACKState?	991
BUS<m>:CAN:FRAMe<n>:CSState?	991
BUS<m>:CAN:FRAMe<n>:DLCState?	991
BUS<m>:CAN:FRAMe<n>:IDState?	991
BUS<m>:CAN:FRAMe<n>:ACKValue?	992
BUS<m>:CAN:FRAMe<n>:CSValue?	992
BUS<m>:CAN:FRAMe<n>:DLCValue?	993
BUS<m>:CAN:FRAMe<n>:IDType?	993
BUS<m>:CAN:FRAMe<n>:IDValue?	993
BUS<m>:CAN:FRAMe<n>:BSEPosition?	994
BUS<m>:CAN:FRAMe<n>:BYTE<o>:STATe?	994
BUS<m>:CAN:FRAMe<n>:BYTE<o>:VALue?	995

BUS<m>:CAN:FCOunt?

Returns the number of decoded frames.

Suffix:

<m> 1..4
Selects the serial bus.

Return values:

<Count> Total number of decoded frames.

Usage: Query only

BUS<m>:CAN:FRAME<n>:STATus?

Returns the overall state of the selected frame.

Suffix:

<m> 1..4
Selects the serial bus.

<n> *
Selects the frame.

Return values:

<FrameState> OK | BTST | CRCD | ACKD | CRC | EOFD | NOACK | CAERror |
FCERror | INSufficient

OK: the frame is valid.

BTST: Bit stuffing error occurred.

CRCD: Wrong CRC delimiter occurred.

ACKD: Wrong ACK delimiter occurred.

CRC: Cyclic redundancy check failed.

EOFD: Wrong end of frame.

NOACK: Acknowledge is missing.

CAERror: CRC error followed by an acknowledgement error
(missing acknowledge)

FCERror: CRC error followed by a form error (wrong CRC delimit-
er or wrong ACK delimiter)

INSufficient: The frame is not completely contained in the acqui-
sition. The acquired part of the frame is valid.

*RST: OK

Usage: Query only

BUS<m>:CAN:FRAME<n>:STARt?**BUS<m>:CAN:FRAME<n>:STOP?**

Return the start time and stop time of the selected frame.

Suffix:

<m> 1..4
Selects the serial bus.

<n> *
Selects the frame.

Return values:

<FrameStart> Time
<FrameStop> Range: -100E+24 to 100E+24
*RST: 0
Default unit: s

Usage: Query only

BUS<m>:CAN:FRAME<n>:TYPE?

Returns the frame type of the selected frame.

Suffix:

<m> 1..4
Selects the serial bus.

<n> *
Selects the frame.

Return values:

<FrameType> DATA | REMote | ERR | OVLD
Data, remote, error or overload frame.
*RST: DATA

Usage: Query only

BUS<m>:CAN:FRAME<n>:DATA?

Returns the data bytes of the specified frame.

Suffix:

<m> 1..4
Selects the serial bus.

<n> *
Selects the frame.

Return values:

<Data> Comma-separated list of values. To set the value format, use [FORMat:BPATtern](#).

Usage: Query only

BUS<m>:CAN:FRAME<n>:ACKState?**BUS<m>:CAN:FRAME<n>:CSState?****BUS<m>:CAN:FRAME<n>:DLCState?****BUS<m>:CAN:FRAME<n>:IDState?**

Return the states of following parts of a message

- ACKState: state of acknowledgement field

- CSSTate: state of checksum field (CRC)
- DLCState: state of data length code
- IDState: identifier state

Suffix:

<m> 1..4
Selects the serial bus.

<n> *
Selects the frame.

Return values:

<State> OK | UNDF
UNDF: Undefined
*RST: OK

Usage: Query only

BUS<m>:CAN:FRAME<n>:ACKValue?

Returns the value of the acknowledge slot for the selected frame.

Suffix:

<m> 1..4
Selects the serial bus.

<n> *
Selects the frame.

Return values:

<AckValue> To set the value format, use [FORMat:BPATtern](#).
The values below – range, increment and reset – are decimal values.

Range: 0 to 1
*RST: 0

Usage: Query only

BUS<m>:CAN:FRAME<n>:CSValue?

Returns the CRC sequence value of the selected frame.

Suffix:

<m> 1..4
Selects the serial bus.

<n> *
Selects the frame.

Return values:

<ChecksumValue> To set the value format, use [FORMat:BPATtern](#).
The values below – range, increment and reset – are decimal values.

Range: 0 to 65535
*RST: 0

Usage: Query only

BUS<m>:CAN:FRAME<n>:DLCValue?

Returns the data length code of the selected frame - the number of data bytes in the frame.

Suffix:

<m> 1..4
Selects the serial bus.

<n> *
Selects the frame.

Return values:

<DataLengthCode> Number of data bytes in decimal values.

Range: 0 to 15
*RST: 0

Usage: Query only

BUS<m>:CAN:FRAME<n>:IDType?

Returns the identifier type of the selected frame, the identifier format of data and remote frames.

Suffix:

<m> 1..4
Selects the serial bus.

<n> *
Selects the frame.

Return values:

<IdentifierType> ANY | B11 | B29
B11: standard format, 11 bit
B29: extended format, 29 bit

*RST: B11

Usage: Query only

BUS<m>:CAN:FRAME<n>:IDValue?

Returns the identifier value of the selected frame.

Suffix:

<m> 1..4
Selects the serial bus.

<n> *
Selects the frame.

Return values:

<IdentifierValue> To set the value format, use [FORMat:BPATtern](#).
The values below – range, increment and reset – are decimal values.

Range: 0 to 536870911

*RST: 0

Usage: Query only

BUS<m>:CAN:FRAME<n>:BSEPosition?

Returns the location of a bit stuffing error.

Suffix:

<m> 1..4
Selects the serial bus.

<n> *
Selects the frame.

Return values:

<BitStuffingErrorPos> Time when the error occurred

Range: -100E+24 to 100E+24

*RST: 0

Default unit: s

Usage: Query only

BUS<m>:CAN:FRAME<n>:BYTE<o>:STATe?

Returns the state of the specified byte.

Suffix:

<m> 1..4
Selects the serial bus.

<n> *
Selects the frame.

<o> *
Selects the byte number.

Return values:

<ByteState> OK | UNDF

UNDF: Undefined

*RST: OK

Usage: Query only

BUS<m>:CAN:FRAME<n>:BYTE<o>:VALue?

Returns the value of the specified byte.

Suffix:

<m>	1..4 Selects the serial bus.
<n>	* Selects the frame.
<o>	* Selects the byte number.

Return values:

<ByteValue> To set the value format, use [FORMat:BPATtern](#).
The values below – range, increment and reset – are decimal values.

Range:	0 to 255
*RST:	0

Usage: Query only

Label List

BUS<m>:SYMBOLs	995
BUS<m>:CAN:FRAME<n>:SYMBOL?	995

BUS<m>:SYMBOLs <UseTranslation>

Activates the label list to be used for decoding.

Suffix:

<m>	1..4 Selects the serial bus.
-----	---------------------------------

Parameters:

<UseTranslation>	ON OFF
*RST:	OFF

Usage: Asynchronous command

Firmware/Software: FW 1.36

BUS<m>:CAN:FRAME<n>:SYMBOL?

Returns the symbolic label of the specified frame if the label list is enabled.

Suffix:

<m>	1..4 Selects the serial bus.
-----	---------------------------------

<n>	*	Selects the number of the frame in the current acquisition, 1...n.
Return values:		
<Label>		String with symbolic label of the identifier
Example:		BUS:CAN:FRAMe:SYMBol? Response: Temperature
Usage:		Query only
Firmware/Software:		FW 1.36

21.2.17.6 LIN (Option R&S RTO-K3)

- [LIN Configuration](#)..... 996
- [LIN Trigger](#)..... 998
- [LIN Decoding Results](#)..... 1005
- [Label List](#)..... 1011

LIN Configuration

BUS<m>:LIN:DATA:SOURce	996
BUS<m>:LIN:DATA:THReshold	996
BUS<m>:LIN:TECHnology	997
BUS<m>:LIN:BITRate	997
BUS<m>:LIN:POLarity	998
BUS<m>:LIN:STANdard	998

BUS<m>:LIN:DATA:SOURce <DataSource>

Sets the waveform of the data line.

Suffix:

<m>	1..4	Selects the serial bus.
-----	------	-------------------------

Parameters:

<DataSource>	C1W1 C2W1 C3W1 C4W1 M1 M2 M3 M4 R1 R2 R3 R4 D0 D1 D2 D3 D4 D5 D6 D7 D8 D9 D10 D11 D12 D13 D14 D15
--------------	---

See [chapter 21.2.3.2, "Waveform Parameter"](#), on page 666

*RST: C1W1

Usage: Asynchronous command

BUS<m>:LIN:DATA:THReshold <Threshold>

Sets a user-defined threshold value.

Alternatively, you can set the threshold according to the signal technology with

[BUS<m>:LIN:TECHnology](#).

Suffix:

<m> 1..4
Selects the serial bus.

Parameters:

<Threshold> Range: -12 to 12
Increment: 0.1
*RST: 0
Default unit: V

BUS<m>:LIN:TECHnology <Technology>

Sets the threshold voltage as defined for various signal technologies.

Suffix:

<m> 1..4
Selects the serial bus.

Parameters:

<Technology> V15 | V25 | V35 | V6 | V9 | MAN

V15

1.5 Volt (TTL)

V25

2.5 Volt (CMOS 5.0 V)

V35 | V6 | V9

3.5 V (7 V supply), 6.0 V (12 V supply), 9.0 V (18 V supply) respectively

MAN

Manual setting of user-defined values with [BUS<m>:LIN:DATA:THReshold](#).

*RST: V35

Usage: SCPI confirmed

BUS<m>:LIN:BITRate <Bitrate>

Sets the number of transmitted bits per second.

Suffix:

<m> 1..4
Selects the serial bus.

Parameters:

<Bitrate> Range: 1000 to 20000
Increment: 1
*RST: 9600
Default unit: bps

BUS<m>:LIN:POLarity <Polarity>

Defines the idle state of the bus. The idle state is the rezessive state and corresponds to a logic 1.

Suffix:

<m> 1..4
Selects the serial bus.

Parameters:

<Polarity> IDLLow | IDLHigh
*RST: IDLHigh

BUS<m>:LIN:STANdard <Standard>

Selects the version of the LIN standard.

See also: "[LIN standard](#)" on page 469

Suffix:

<m> 1..4
Selects the serial bus.

Parameters:

<Standard> V1X | V2X | J2602 | AUTO
*RST: AUTO

LIN Trigger

TRIGger<m>:LIN:TYPE.....	998
TRIGger<m>:LIN:ICONdition.....	999
TRIGger<m>:LIN:IMIN.....	1000
TRIGger<m>:LIN:IMAX.....	1000
TRIGger<m>:LIN:DCONdition.....	1000
TRIGger<m>:LIN:DMIN.....	1001
TRIGger<m>:LIN:DMAX.....	1001
TRIGger<m>:LIN:BORDER.....	1001
TRIGger<m>:LIN:DLECondition.....	1002
TRIGger<m>:LIN:DLENgth.....	1002
TRIGger<m>:LIN:IDOR<n>:ENABle.....	1003
TRIGger<m>:LIN:IDOR<n>:[:VALue].....	1003
TRIGger<m>:LIN:SYERror.....	1003
TRIGger<m>:LIN:IPERror.....	1004
TRIGger<m>:LIN:CHKSError.....	1004
TRIGger<m>:LIN:ERRPattern.....	1004
TRIGger<m>:LIN:CRCDatalen.....	1005
TRIGger<m>:LIN:STANdard.....	1005

TRIGger<m>:LIN:TYPE <Type>

Selects the trigger type for LIN analysis.

See: "Trigger type" on page 470.

Suffix:

<m> 1..3
Event in a trigger sequence: 1 = A-event only

Parameters:

<Type> SYNC | ID | IDOR | IDDT | WKFR | ERRC

SYNC

Start of the frame, triggers on the stop bit of the sync field.

ID

Sets the trigger to one specific identifier or an identifier range.

To set the identifier, use `TRIGger<m>:LIN:ICONdition`, `TRIGger<m>:LIN:IMIN` on page 1000, and `TRIGger<m>:LIN:IMAX` on page 1000.

IDOR

Triggers on an OR combination with up to four identifier conditions. For each identifier condition, enable it with `TRIGger<m>:LIN:IDOR<n>:ENABLE` and set the value with `TRIGger<m>:LIN:IDOR<n>[:VALue]`

IDDT

Combination of identifier and data conditions

To set the identifier condition, use `TRIGger<m>:LIN:ICONdition`, `TRIGger<m>:LIN:IMIN`, and `TRIGger<m>:LIN:IMAX`.

To set the data condition, use `TRIGger<m>:LIN:DCONdition`, `TRIGger<m>:LIN:DMIN`, and `TRIGger<m>:LIN:DMAX`.

WKFR

Wakeup frame

ERRC

Error condition. Define the error types with `TRIGger<m>:LIN:CHKSError` on page 1004, `TRIGger<m>:LIN:IPERror`, and `TRIGger<m>:LIN:SYERror`

*RST: SYNC

TRIGger<m>:LIN:ICONdition <IdentifierOperator>

Sets the operator to set a specific identifier or an identifier range.

Suffix:

<m> 1..3
Event in a trigger sequence: 1 = A-event only

Parameters:

<IdentifierOperator> EQUal | NEQual | LTHan | LETHan | GTHan | GETHan | INRange | OORange

EQUal | NEQual | LTHan | LETHan | GTHan | GETHan

Equal, Not equal, Less than, Less or equal than, Greater Than, Greater or equal than. These condition require one identifier pattern to be set with [TRIGger<m>:LIN:IMIN](#)

INRange | OORange

In range / Out of range: Set the minimum and maximum value of the range with [TRIGger<m>:LIN:IMIN](#) and [TRIGger<m>:LIN:IMAX](#)

*RST: EQUal

TRIGger<m>:LIN:IMIN <IdPattern>

Specifies a slave identifier pattern, or sets the the start value of an identifier range.

Suffix:

<m> 1..3
Event in a trigger sequence: 1 = A-event only

Parameters:

<IdPattern> Numeric or string pattern, see [chapter 21.2.3.6, "Bit Pattern Parameter"](#), on page 667.

TRIGger<m>:LIN:IMAX <IdPatternTo>

Sets the the end value of an identifier range if [TRIGger<m>:LIN:ICONdition](#) is set to [INRange](#) or [OORange](#).

Suffix:

<m> 1..3
Event in a trigger sequence: 1 = A-event only

Parameters:

<IdPatternTo> Numeric or string pattern, see [chapter 21.2.3.6, "Bit Pattern Parameter"](#), on page 667.

TRIGger<m>:LIN:DCONDITION <DataOperator>

Sets the operator to set a specific data pattern or a data pattern range.

Suffix:

<m> 1..3
Event in a trigger sequence: 1 = A-event only

Parameters:

<DataOperator> EQUal | NEQual | LTHan | LETHan | GTHan | GETHan |
 INRange | OORange

EQUal | NEQual | LTHan | LETHan | GTHan | GETHan
 Equal, Not equal, Less than, Less or equal than, Greater Than,
 Greater or equal than. These conditions require one data pattern
 to be set with [TRIGger<m>:LIN:DMIN](#).

INRange | OORange
 In range / Out of range: Set the minimum and maximum value of
 the range with [TRIGger<m>:LIN:DMIN](#) and [TRIGger<m>:
 LIN:DMAX](#)

*RST: EQUal

TRIGger<m>:LIN:DMIN <DataPattern>

Specifies a data pattern, or sets the the start value of a data pattern range.

Suffix:

<m> 1..3
 Event in a trigger sequence: 1 = A-event only

Parameters:

<DataPattern> Numeric or string pattern, see [chapter 21.2.3.6, "Bit Pattern
 Parameter"](#), on page 667. The string parameter accepts the bit
 value X (don't care).

TRIGger<m>:LIN:DMAX <DataPatternTo>

Sets the the end value of an data range if [TRIGger<m>:LIN:DCondition](#) is set to
 INRange or OORange.

Suffix:

<m> 1..3
 Event in a trigger sequence: 1 = A-event only

Parameters:

<DataPatternTo> Numeric or string pattern, see [chapter 21.2.3.6, "Bit Pattern
 Parameter"](#), on page 667. The string parameter accepts the bit
 value X (don't care).

TRIGger<m>:LIN:BORDER <Endianness>

Sets the byte order (endianness) of the data transfer.

According to the standard, LIN data is transmitted in little endian transfer order.

Suffix:

<m> 1..3
 Event in a trigger sequence: 1 = A-event only

Parameters:

<Endianness> BENDian | LENDian

BENDian

Big endian, data is analyzed and evaluated in the order of reception.

LENDian

Little endian, the instrument reads the complete data and then compares it with the data pattern in reverse order.

*RST: BENDian

TRIGger<m>:LIN:DLECondition <DLCOperator>

Operator to set the data length code for triggering on LIN data. For big endian transfer direction, you can trigger on a number of bytes less than the data length of the frame, that means, on the beginning of the data pattern. For little endian transfer direction, the exact number of data bytes in the frame must be set. The number of data bytes to be found is set with [TRIGger<m>:LIN:DLEnGth](#) on page 1002.

Example: Data length ≥ 2 and Transfer = Big endian. The frame has at least two bytes, and you trigger on the data of the first two bytes.

See also: [TRIGger<m>:LIN:BOrDer](#) on page 1001 .

Suffix:

<m> 1..3
Event in a trigger sequence: 1 = A-event only

Parameters:

<DLCOperator> EQUal | GETHan
For little endian transfer direction, EQUal must be set.
*RST: GETHan

TRIGger<m>:LIN:DLEnGth <WordCount>

Sets the length of the bit pattern to be found, in bytes. For "Big Endian" transfer direction, you can trigger on a number of bytes less than the data length of the frame, that means, on the beginning of the data pattern. For "Little Endian" transfer direction, the exact number of data bytes in the frame must be set.

For complete definition, set also the operator with [TRIGger<m>:LIN:DLECondition](#) on page 1002.

Suffix:

<m> 1..3
<m> 1..3
Event in a trigger sequence: 1 = A-event only

Parameters:

<WordCount> Range: 1 to 8
 Increment: 1
 *RST: 1

TRIGger<m>:LIN:IDOR<n>:ENABLE <UseIdentifier>

Includes the indicated IDOR address in the "identifier OR" trigger condition.

Suffix:

<m> 1..3
 Event in a trigger sequence: 1 = A-event only

<n> 1..4
 Index of the identifier in an "identifier OR" condition

Parameters:

<UseIdentifier> ON | OFF
 *RST: OFF

Firmware/Software: V 1.25

TRIGger<m>:LIN:IDOR<n>[:VALue] <IdentifierPattern>

Defines the pattern of the indicated IDOR identifier in the "identifier OR" trigger condition.

Suffix:

<m> 1..3
 Event in a trigger sequence: 1 = A-event only

<n> 1..4
 Index of the identifier in an "identifier OR" condition

Parameters:

<IdentifierPattern> Numeric or string pattern, see [chapter 21.2.3.6, "Bit Pattern Parameter"](#), on page 667. The parameter accepts the bit value X (don't care).

Firmware/Software: V 1.25

TRIGger<m>:LIN:SYERror <SyncError>

Triggers if a synchronization error occurs.

The trigger type has to be set before: **TRIGger<m>:LIN:TYPE** to **ERRC**.

Suffix:

<m> 1..3
 Event in a trigger sequence: 1 = A-event only

Parameters:

<SyncError> ON | OFF
 *RST: ON

TRIGger<m>:LIN:IPERror <IdParityError>

Triggers if an error occurs in the identifier parity bits. These are the bits 6 and 7 of the identifier.

The trigger type has to be set before: [TRIGger<m>:LIN:TYPE](#) to `ERRC`.

Suffix:

<m> 1..3
 Event in a trigger sequence: 1 = A-event only

Parameters:

<IdParityError> ON | OFF
 *RST: ON

TRIGger<m>:LIN:CHKSError <ChecksumError>

Triggers on checksum errors according to the LIN standard set with [BUS<m>:LIN:STANdard](#).

The trigger type has to be set before: [TRIGger<m>:LIN:TYPE](#) to `ERRC`.

The frame identifier must be set with [TRIGger<m>:LIN:ERRPattern](#) on page 1004 and the data length with [TRIGger<m>:LIN:CRCDatalen](#) on page 1005.

Suffix:

<m> 1..3
 Event in a trigger sequence: 1 = A-event only

Parameters:

<ChecksumError> ON | OFF
 *RST: ON

TRIGger<m>:LIN:ERRPattern <ErrorPattern>

Sets the frame identifier to trigger on a checksum error with [TRIGger<m>:LIN:CHKSError](#) on page 1004.

Suffix:

<m> 1..3
 Event in a trigger sequence: 1 = A-event only

Parameters:

<ErrorPattern> Numeric or string pattern, see [chapter 21.2.3.6, "Bit Pattern Parameter"](#), on page 667.

Firmware/Software: V 1.25

TRIGger<m>:LIN:CRCDatalen <CRCDataLength>

Sets the number of data bytes to trigger on CRC errors (**TRIGger<m>:LIN:TYPE** is set to **ERRC** and **TRIGger<m>:LIN:CHKSError** is set **ON**.)

Suffix:

<m> 1..3
Event in a trigger sequence: 1 = A-event only

Parameters:

<CRCDataLength> Range: 0 to 8
Increment: 1
*RST: 0

TRIGger<m>:LIN:STANdard <ChecksumStandard>

Sets the LIN standard to trigger on CRC errors (**TRIGger<m>:LIN:TYPE** is set to **ERRC** and **TRIGger<m>:LIN:CHKSError** is set **ON**.)

See also: "[LIN standard](#)" on page 469.

Suffix:

<m> 1..3
Event in a trigger sequence: 1 = A-event only

Parameters:

<ChecksumStandard> V1X | V2X | J2602 | AUTO
*RST: AUTO

LIN Decoding Results

BUS<m>:LIN:FCOut?	1005
BUS<m>:LIN:FRAMe<n>:STATus?	1006
BUS<m>:LIN:FRAMe<n>:START?	1006
BUS<m>:LIN:FRAMe<n>:STOP?	1006
BUS<m>:LIN:FRAMe<n>:VERSion?	1007
BUS<m>:LIN:FRAMe<n>:DATA?	1007
BUS<m>:LIN:FRAMe<n>:IDSTate?	1007
BUS<m>:LIN:FRAMe<n>:IDValue?	1008
BUS<m>:LIN:FRAMe<n>:IDPValue?	1008
BUS<m>:LIN:FRAMe<n>:SYSTate?	1009
BUS<m>:LIN:FRAMe<n>:CSSTate?	1009
BUS<m>:LIN:FRAMe<n>:CSValue?	1009
BUS<m>:LIN:FRAMe<n>:BYTE<o>:STATe?	1010
BUS<m>:LIN:FRAMe<n>:BYTE<o>:VALue?	1010

BUS<m>:LIN:FCOut?

Returns the number of decoded frames.

Suffix:

<m> 1..4
Selects the serial bus.

Return values:

<Count> Total number of decoded frames.

Usage: Query only

BUS<m>:LIN:FRAME<n>:STATus?

Returns the overall state of the selected frame.

Suffix:

<m> 1..4
Selects the serial bus.

<n> *
Selects the frame.

Return values:

<FrameState> OK | UART | CHCKsum | VERS | LENer | SPERror | PRERror | SYERror | WAKeup | CPERror | INSufficient
 UART: at least one UART error occured. LIN uses UART words without parity bit.
 CHCKsum: checksum error
 VERS: the version of the LIN standard is not valid
 LENer: unexpected length
 SPERror: stop error
 PRERror: parity error in identifier
 SYERror: synchronization error
 WAKeup: the frame is a wakeup frame
 CPERror: parity error and checksum error
 INSufficient: the frame is not completely contained in the acquisition. The decoded part of the frame is valid.
 *RST: OK

Usage: Query only

BUS<m>:LIN:FRAME<n>:START?**BUS<m>:LIN:FRAME<n>:STOP?**

Returns the start time and stop time of the selected frame, respectively.

Suffix:

<m> 1..4
Selects the serial bus.

<n> *
Selects the frame.

Return values:

<FrameStart> Range: -100E+24 to 100E+24
 <FrameStop> *RST: 0
 Default unit: s

Usage: Query only

BUS<m>:LIN:FRAMe<n>:VERSion?

Returns the version of the LIN standard for the specified frame.

Suffix:

<m> 1..4
 Selects the serial bus.
 <n> *
 Selects the frame.

Return values:

<FrameVersion> V1X | V2X | UNK
 UNK: Unknown
 *RST: UNK

Usage: Query only

BUS<m>:LIN:FRAMe<n>:DATA?

Returns the data bytes of the specified frame.

Suffix:

<m> 1..4
 Selects the serial bus.
 <n> *
 Selects the frame.

Return values:

<Data> Comma-separated list of data bytes. To set the value format,
 use [FORMat:BPATtern](#).

Usage: Query only

BUS<m>:LIN:FRAMe<n>:IDState?

Returns the identifier state of the selected frame.

Suffix:

<m> 1..4
 Selects the serial bus.
 <n> *
 Selects the frame.

Return values:

<IdentifierState> OK | STERror | SPERror | PRERror | UVAL | NOEXists |
 INSufficient
 STERror: start error
 SPERror: stop error
 PRERror: parity error
 UVAL: unexpected value
 NOEXists: byte does not exist
 INSufficient: the frame is not completely contained in the acquisition. The decoded part of the frame is valid.
 *RST: OK

Usage: Query only

BUS<m>:LIN:FRAMe<n>:IDValue?

Returns the identifier value of the selected frame.

Suffix:

<m> 1..4
 Selects the serial bus.
 <n> *
 Selects the frame.

Return values:

<IdentifierValue> To set the value format, use [FORMat:BPATtern](#).
 The values below – range, increment and reset – are decimal values.
 Range: 0 to 63
 *RST: 0

Usage: Query only

BUS<m>:LIN:FRAMe<n>:IDPValue?

Returns the value of the identifier parity bits of the selected frame.

Suffix:

<m> 1..4
 Selects the serial bus.
 <n> *
 Selects the frame.

Return values:

<IdentifierParity> To set the value format, use [FORMat:BPATtern](#).
 The values below – range, increment and reset – are decimal values.
 Range: 0 to 3
 *RST: 0

Usage: Query only

BUS<m>:LIN:FRAME<n>:SYSTate?

Returns the state of the sync field for the specified frame.

Suffix:

<m> 1..4
Selects the serial bus.

<n> *
Selects the frame.

Return values:

<SyncState> OK | STERror | SPERror | UVAL | NOEXists | INSufficient
 STERror: start error
 SPERror: stop error
 UVAL: unexpected value
 NOEXists: byte does not exist
 INSufficient: the frame is not completely contained in the acquisition. The decoded part of the frame is valid.
 *RST: OK

Usage: Query only

BUS<m>:LIN:FRAME<n>:CSSTate?

Returns the checksum state of the specified frame.

Suffix:

<m> 1..4
Selects the serial bus.

<n> *
Selects the frame.

Return values:

<ChecksumState> OK | STERror | SPERror | UVAL | NOEXists | INSufficient
 STERror: start error
 SPERror: stop error
 UVAL: unexpected value
 NOEXists: byte does not exist
 INSufficient: the frame is not completely contained in the acquisition. The decoded part of the frame is valid.
 *RST: OK

Usage: Query only

BUS<m>:LIN:FRAME<n>:CSValue?

Returns the checksum value of the specified frame.

Suffix:

<m> 1..4
Selects the serial bus.

<n> *
Selects the frame.

Return values:

<ChecksumValue> To set the value format, use [FORMat:BPATtern](#).
The values below – range, increment and reset – are decimal values.

Range: 0 to 255

*RST: 0

Usage: Query only

BUS<m>:LIN:FRAMe<n>:BYTE<o>:STATe?

Returns the state of the specified byte.

Suffix:

<m> 1..4
Selects the serial bus.

<n> *
Selects the frame.

<o> *
Selects the byte number.

Return values:

<ByteState> OK | STERror | SPERror | UVAL | NOEXists | INSufficient
 STERror: start error
 SPERror: stop error
 UVAL: unexpected value
 NOEXists: byte does not exist
 INSufficient: the frame is not completely contained in the acquisition. The decoded part of the frame is valid.

*RST: OK

Usage: Query only

BUS<m>:LIN:FRAMe<n>:BYTE<o>:VALue?

Returns the value of the specified byte.

Suffix:

<m> 1..4
Selects the serial bus.

<n> *
Selects the frame.

<0> *
Selects the byte.

Return values:

<ByteValue> To set the value format, use `FORMat:BPATtern`.
The values below – range, increment and reset – are decimal values.

Range: 0 to 255

*RST: 0

Usage: Query only

Label List

`BUS<m>:SYMBols`..... 1011

`BUS<m>:LIN:FRAMe<n>:SYMBol?`..... 1011

BUS<m>:SYMBols <UseTranslation>

Activates the lable list to be used for decoding.

Suffix:

<m> 1..4
Selects the serial bus.

Parameters:

<UseTranslation> ON | OFF
*RST: OFF

Usage: Asynchronous command

Firmware/Software: FW 1.36

BUS<m>:LIN:FRAMe<n>:SYMBol?

Returns the symbolic label of the specified frame if the label list is enabled.

Suffix:

<m> 1..4
Selects the serial bus.

<n> *
Selects the number of the frame in the current acquisition, 1...n.

Return values:

<Label> String with symbolic name of the identifier

Example:

`BUS:LIN:FRAMe2:SYMBol?`

Response: Temperature

Usage: Query only

Firmware/Software: FW 1.36

21.2.17.7 FlexRay (Option R&S RTO-K4)

• FlexRay Configuration.....	1012
• FlexRay Trigger.....	1016
• FlexRay Decoding Results.....	1027
• Label List.....	1032

FlexRay Configuration

BUS<m>:FLXRay:SRCType.....	1012
BUS<m>:FLXRay:SOURce<n>.....	1013
BUS<m>:FLXRay:THReshold<n>.....	1013
BUS<m>:FLXRay:THENable.....	1013
BUS<m>:FLXRay:THData.....	1014
BUS<m>:FLXRay:PRSingle.....	1014
BUS<m>:FLXRay:PRDiff.....	1014
BUS<m>:FLXRay:PRLogic.....	1015
BUS<m>:FLXRay:POLarity.....	1015
BUS<m>:FLXRay:BITRate.....	1015
BUS<m>:FLXRay:CHTType.....	1016
BUS<m>:FLXRay:SEHB.....	1016

BUS<m>:FLXRay:SRCType <SourceType>

Sets the type of measurement.

Suffix:

<m> 1..4
Selects the serial bus.

Parameters:

<SourceType> SINGLE | DIFFerential | LOGic

SINGLE

Used for measurements with single-ended probes or single-ended voltage measurements with differential probes on the FlexRay bus. Two thresholds have to be defined as absolute voltage levels, see [BUS<m>:FLXRay:THReshold<n>](#) on page 1013.

DIFFerential

Used for differential measurements on the FlexRay bus. This is the most common measurement. Two thresholds have to be defined as differential voltages.

LOGic

Used for measurements of the logic signal inside the FlexRay node, between the communication controller and the bus driver. It is possible to measure simultaneously on a data line and on the "enable" line. Each line requires its own threshold.

*RST: SINGLE

BUS<m>:FLXRay:SOURce<n> <Sources>

Sets the input channel of the bus signal, or of the data and enable lines in case of a LOGic source type.

Suffix:

<m>	1..4 Selects the serial bus.
<n>	1 2 Selects the source: 1 = bus signal or data line, 2 = enable line

Parameters:

<Sources>	NONE C1W1 C2W1 C3W1 C4W1 M1 M2 M3 M4 R1 R2 R3 R4 D0 D1 D2 D3 D4 D5 D6 D7 D8 D9 D10 D11 D12 D13 D14 D15 NONE: only available for SOURce2 (enable line) Reference and math waveforms are only available if the trigger source is one of the input channels but not the serial bus. Digital and analog channels cannot be used at the same time for data and enable lines.
-----------	--

BUS<m>:FLXRay:THReshold<n> <THResholds>

Sets the thresholds for the bus signal if the source type is SINGLE or DIFFerential.

For LOGic source type, use [BUS<m>:FLXRay:THData](#) on page 1014 and [BUS<m>:FLXRay:THENable](#) on page 1013.

Suffix:

<m>	1..4 Selects the serial bus.
<n>	1 2 1 = threshold high, 2 = threshold low

Parameters:

<THResholds>	Differential or absolute voltage level, depending on the source type. See BUS<m>:FLXRay:SRCType on page 1012.
--------------	---

BUS<m>:FLXRay:THENable <ThresholdEnable>

Sets the threshold for the enable line if the source type is LOGic.

Suffix:

<m>	1..4 Selects the serial bus.
-----	---------------------------------

Parameters:

<ThresholdEnable>	Range: -12 to 12 Increment: 0.1 *RST: 2.65 Default unit: V
-------------------	---

BUS<m>:FLXRay:THData <ThresholdData>

Sets the threshold for the data line if the source type is LOGic.

Suffix:

<m> 1..4
Selects the serial bus.

Parameters:

<ThresholdData> Range: -12 to 12
Increment: 0.1
*RST: 2.35
Default unit: V

BUS<m>:FLXRay:PRSingle <PresetSingleEnded>

Selects a default threshold voltage if [BUS<m>:FLXRay:SRCType](#) is set to SINGle.

Suffix:

<m> 1..4
Selects the serial bus.

Parameters:

<PresetSingleEnded> MV150 | MV200 | MV250 | MV300 | MAN
MV150 | MV200 | MV250 | MV300
2.5 ± 0.15 V; 2.5 ± 0.2 V; 2.5 ± 0.25 V; 2.5 ± 0.3 V, respectively
MAN
Manual setting of user-defined values with [BUS<m>:FLXRay:THReshold<n>](#) on page 1013.
*RST: MV150

BUS<m>:FLXRay:PRDiff <PresetDifferential>

Selects a default threshold voltage if [BUS<m>:FLXRay:SRCType](#) is set to DIFFerential.

Suffix:

<m> 1..4
Selects the serial bus.

Parameters:

<PresetDifferential> MV150 | MV200 | MV250 | MV300 | MAN
MV150 | MV200 | MV250 | MV300
±150 mV, ±200 mV, ±250 mV, ±300 mV respectively
MAN
Manual setting of user-defined values with [BUS<m>:FLXRay:THReshold<n>](#) on page 1013.
*RST: MV150

BUS<m>:FLXRay:PRLogic <PresetLogic>

Selects a default threshold voltage if **BUS<m>:FLXRay:SRCType** is set to **LOGic**.

Suffix:

<m> 1..4
Selects the serial bus.

Parameters:

<PresetLogic> V25 | V165 | V125 | V09 | V0 | MAN
V25 | V165 | V125 | V09 | V0
2.5 V (CMOS 5.0 V); 1.65 V (CMOS 3.5V), 1.25 V (CMOS 2.5V),
0.9 V (CMOS 1.8V), 0 V (ground)
MAN
Manual setting of user-defined values with **BUS<m>:FLXRay:THReshold<n>** on page 1013.
*RST: V25

BUS<m>:FLXRay:POLarity <Polarity>

Selects the wire on which the bus signal is measured in case of **SINGLE** source type. The setting affects the digitization of the signal.

Suffix:

<m> 1..4
Selects the serial bus.

Parameters:

<Polarity> BPLus | BMINus
*RST: BPLus

BUS<m>:FLXRay:BITRate <Bitrate>

Selects the number of transmitted bits per second.

Suffix:

<m> 1..4
Selects the serial bus.

Parameters:

<Bitrate> M10 | M5 | M2_5
10, 5, or 2.5 Mbit/s.
The return value of 2.5 Mbit/s is M25.
*RST: M10

Example:

```
BUS:FLXRay:BITRate M2_5
BUS:FLXRay:BITRate?
M25
```

BUS<m>:FLXRay:CHType <Channel>

Selects the channel on which the signal is measured. The setting is considered in the calculation of the frame CRC.

Suffix:

<m> 1..4
Selects the serial bus.

Parameters:

<Channel> CHA | CHB
Channel A or channel B
*RST: CHA

BUS<m>:FLXRay:SEHB <SeparateHeaderBits>

The command affects the decoding and its display. If ON, the leading five indicator bits of the header are decoded as five single bits. Otherwise, the indicator bits are shown as one word with word length five bit.

Suffix:

<m> 1..4
Selects the serial bus.

Parameters:

<SeparateHeaderBits>ON | OFF
*RST: OFF

FlexRay Trigger

TRIGger<m>:FLXRay:TYPE.....	1017
TRIGger<m>:FLXRay:PLPReamble.....	1018
TRIGger<m>:FLXRay:NUFRame.....	1019
TRIGger<m>:FLXRay:SYFRame.....	1019
TRIGger<m>:FLXRay:STFRame.....	1019
TRIGger<m>:FLXRay:FCONdition.....	1020
TRIGger<m>:FLXRay:FMIN.....	1020
TRIGger<m>:FLXRay:FMAX.....	1020
TRIGger<m>:FLXRay:PCONdition.....	1021
TRIGger<m>:FLXRay:PMIN.....	1021
TRIGger<m>:FLXRay:PMAX.....	1021
TRIGger<m>:FLXRay:CENable.....	1022
TRIGger<m>:FLXRay:CMIN.....	1022
TRIGger<m>:FLXRay:CMAX.....	1022
TRIGger<m>:FLXRay:CSTep.....	1023
TRIGger<m>:FLXRay:DPOperator.....	1023
TRIGger<m>:FLXRay:DPOStition.....	1024
TRIGger<m>:FLXRay:DPTO.....	1024
TRIGger<m>:FLXRay:DCONdition.....	1024
TRIGger<m>:FLXRay:DMIN.....	1025
TRIGger<m>:FLXRay:DMAX.....	1025

TRIGger<m>:FLXRay:SYMBOL.....	1025
TRIGger<m>:FLXRay:BSError.....	1025
TRIGger<m>:FLXRay:FSError.....	1026
TRIGger<m>:FLXRay:FSSerror.....	1026
TRIGger<m>:FLXRay:HCRError.....	1026
TRIGger<m>:FLXRay:PCRError.....	1026

TRIGger<m>:FLXRay:TYPE <Type>

Selects the trigger type for FlexRay analysis.

Suffix:

<m>

1..3

Event in a trigger sequence: 1 = A-event only

Parameters:

<Type>

STOF | IDDT | SYMBoI | ERRc

STOF

STart Of Frame: triggers on the first rising edge after the transmission start sequence (TSS).

IDDT

IDentifier and DaTa: triggers on the decoded frame content, on header and payload data.

For all settings that are not needed for the trigger condition, make sure to set its condition to OFF.

Indicator bits: see [TRIGger<m>:FLXRay:NUFRame](#)

Frame identifier: sets the trigger to one specific frame ID or an identifier range. To set the identifier, use [TRIGger<m>:FLXRay:FCONdition](#), [TRIGger<m>:FLXRay:FMIN](#), and [TRIGger<m>:FLXRay:FMAX](#).

Payload length: trigger on the number of words in the payload segment. To set the payload length, use [TRIGger<m>:FLXRay:PCONdition](#), [TRIGger<m>:FLXRay:PMIN](#), and [TRIGger<m>:FLXRay:PMAX](#).

Cycle count: trigger on the number of the current FlexRay cycle. To set the cycle count, use [TRIGger<m>:FLXRay:CENable](#), [TRIGger<m>:FLXRay:CMIN](#), [TRIGger<m>:FLXRay:CMAX](#), and [TRIGger<m>:FLXRay:CSTep](#).

Data position: sets the position of the data bit pattern within the payload segment. To set the data position, use [TRIGger<m>:FLXRay:DPOperator](#), [TRIGger<m>:FLXRay:DPOSITION](#), and [TRIGger<m>:FLXRay:DPTO](#).

Data bit pattern: sets the data bit pattern to be found in the payload segment. The starting point of the pattern is defined by the data position. To set the bit pattern, use [TRIGger<m>:FLXRay:DCONdition](#), [TRIGger<m>:FLXRay:DMIN](#), and [TRIGger<m>:FLXRay:DMAX](#).

SYMBoI

Triggers on a symbol or wakeup pattern. Set the required symbol with [TRIGger<m>:FLXRay:SYMBoI](#)

ERRc

ERRor Condition: triggers on one or more errors that are detected in the decoded data. Use [TRIGger<m>:FLXRay:BSSerror](#), [TRIGger<m>:FLXRay:FESerror](#), [TRIGger<m>:FLXRay:FSSerror](#), and [TRIGger<m>:FLXRay:PCRCerror](#).

*RST: STOF

TRIGger<m>:FLXRay:PLPReamble <PayloadPreamble>

Triggers on the payload preamble indicator bit that indicates a Network Management Vector in the payload segment.

Suffix:

<m> 1..3
Event in a trigger sequence: 1 = A-event only

Parameters:

<PayloadPreamble> ONE | ZERO | DC
Bit value: 1, 0, or X (don't care)
*RST: ONE

TRIGger<m>:FLXRay:NUFRame <NullFrame>

Triggers on the null frame indicator bit, a frame without usable data.

Suffix:

<m> 1..3
Event in a trigger sequence: 1 = A-event only

Parameters:

<NullFrame> ONE | ZERO | DC
Bit value: 1, 0, or X (don't care)
*RST: ZERO

TRIGger<m>:FLXRay:SYFRame <SyncFrame>

Triggers on the sync frame used for synchronization of the FlexRay system. Only sync nodes can send this frame type.

Suffix:

<m> 1..3
Event in a trigger sequence: 1 = A-event only

Parameters:

<SyncFrame> ONE | ZERO | DC
Bit value: 1, 0, or X (don't care)
*RST: DC

TRIGger<m>:FLXRay:STFRame <StartupFrame>

Triggers on startup frames used for startup of the network. Only specific start nodes can send this frame type.

Suffix:

<m> 1..3
Event in a trigger sequence: 1 = A-event only

Parameters:

<StartupFrame> ONE | ZERO | DC
Bit value: 1, 0, or X (don't care)
*RST: DC

TRIGger<m>:FLXRay:FCONdition <IdentifierOperator>

Sets the operator to set a frame ID or a frame ID range.

Suffix:

<m> 1..3
Event in a trigger sequence: 1 = A-event only

Parameters:

<IdentifierOperator> OFF | EQUal | NEQual | LTHan | LETHan | GTHan | GETHan | INRange | OORange

OFF

The frame ID is not relevant for the trigger condition.

EQUal | NEQual | LTHan | LETHan | GTHan | GETHan

Equal, Not equal, Less than, Less or equal than, Greater Than, Greater or equal than. These conditions require one frame ID to be set with [TRIGger<m>:FLXRay:FMIN](#).

INRange | OORange

In range / Out of range: Set the minimum and maximum value of the range with [TRIGger<m>:FLXRay:FMIN](#) and [TRIGger<m>:FLXRay:FMAX](#).

*RST: EQUal

TRIGger<m>:FLXRay:FMIN <IdPattern>

Specifies a frame identifier pattern - the number of the slot - or sets the the start value of an identifier range.

Suffix:

<m> 1..3
Event in a trigger sequence: 1 = A-event only

Parameters:

<IdPattern> Numeric or string pattern, see [chapter 21.2.3.6, "Bit Pattern Parameter"](#), on page 667.

TRIGger<m>:FLXRay:FMAX <IdPatternTo>

Sets the the end value of an identifier range if the condition [TRIGger<m>:FLXRay:FCONdition](#) is set to [INRange](#) or [OORange](#).

Suffix:

<m> 1..3
Event in a trigger sequence: 1 = A-event only

Parameters:

<IdPatternTo> Numeric or string pattern, see [chapter 21.2.3.6, "Bit Pattern Parameter"](#), on page 667.

TRIGger<m>:FLXRay:PCONdition <PLOperator>

Sets the operator for the payload length trigger setting. You can defined an exact value, or a range.

Suffix:

<m> 1..3
Event in a trigger sequence: 1 = A-event only

Parameters:

<PLOperator> OFF | EQUal | NEQual | LTHan | LETHan | GTHan | GETHan | INRange | OORange

OFF

The payload length is not relevant for the trigger condition.

EQUal | NEQual | LTHan | LETHan | GTHan | GETHan

Equal, Not equal, Less than, Less or equal than, Greater Than, Greater or equal than. These conditions require one payload length to be set with [TRIGger<m>:FLXRay:PMIN](#).

INRange | OORange

In range / Out of range: Set the minimum and maximum value of the range with [TRIGger<m>:FLXRay:PMIN](#) and [TRIGger<m>:FLXRay:PMAX](#).

*RST: OFF

TRIGger<m>:FLXRay:PMIN <PayloadLength>

Specifies a payload length - the number of words in the payload segment - or sets the the start value of an payload length range. Information is transmitted in 2-byte words, so the number of data bytes in the payload segment is twice the payload length.

Suffix:

<m> 1..3
Event in a trigger sequence: 1 = A-event only

Parameters:

<PayloadLength> Range: 0 to 127
Increment: 1
*RST: 0

TRIGger<m>:FLXRay:PMAX <PayloadLengthTo>

Sets the the end value of a payload length range if the condition [TRIGger<m>:FLXRay:PCONdition](#) is set to [INRange](#) or [OORange](#).

Suffix:

<m> 1..3
Event in a trigger sequence: 1 = A-event only

Parameters:

<PayloadLengthTo> Range: 0 to 127
 Increment: 1
 *RST: 0

TRIGger<m>:FLXRay:CENable <CycleCount>

Sets the operator to define a cycle count or a cycle count range.

Suffix:

<m> 1..3
 Event in a trigger sequence: 1 = A-event only

Parameters:

<CycleCount> OFF | EQUal | NEQual | LTHan | LETHan | GTHan | GETHan |
 INRange | OORange

OFF

The cycle count is not relevant for the trigger condition.

EQUal | NEQual | LTHan | LETHan | GTHan | GETHan

Equal, Not equal, Less than, Less or equal than, Greater Than, Greater or equal than. These conditions require one cycle count number to be set with [TRIGger<m>:FLXRay:CMIN](#).

INRange | OORange

In range / Out of range: Set the minimum and maximum value of the range with [TRIGger<m>:FLXRay:CMIN](#) and [TRIGger<m>:FLXRay:CMAX](#).

*RST: OFF

TRIGger<m>:FLXRay:CMIN <CycleCount>

Specifies a cycle count - the number of the current FlexRay cycle - or sets the the start value of an cycle count range.

Suffix:

<m> 1..3
 Event in a trigger sequence: 1 = A-event only

Parameters:

<CycleCount> Range: 0 to 63
 Increment: 1
 *RST: 0

TRIGger<m>:FLXRay:CMAX <CycleCountTo>

Sets the the end value of a cycle count range if the condition [TRIGger<m>:FLXRay:CENable](#) on page 1022 is set to [INRange](#) or [OORange](#).

Suffix:

<m> 1..3
Event in a trigger sequence: 1 = A-event only

Parameters:

<CycleCountTo> Range: 0 to 63
Increment: 1
*RST: 0

TRIGger<m>:FLXRay:CSTep <CycleCountStep>

Specifies a step to trigger on each n-th cycle inside the given range. This allows for specific triggering if slot multiplexing is used.

The condition [TRIGger<m>:FLXRay:CENable](#) on page 1022 must be set to `INRange` or `OORange`.

Suffix:

<m> 1..3
Event in a trigger sequence: 1 = A-event only

Parameters:

<CycleCountStep> Range: 1 to 63
Increment: 1
*RST: 1

TRIGger<m>:FLXRay:DPOperator <DataPosiOperator>

Sets the operator for the data position. You can defined an exact position, or a position range.

Suffix:

<m> 1..3
Event in a trigger sequence: 1 = A-event only

Parameters:

<DataPosiOperator> OFF | EQUAL | GETHan | INRange

OFF

The data position is not relevant for the trigger condition.

EQUAL | GETHan

Equal, Greater or equal than. These conditions require one data position to be set with [TRIGger<m>:FLXRay:DPOsition](#).

INRange

In range: Set the minimum and maximum value of the range with [TRIGger<m>:FLXRay:DPOsition](#) and [TRIGger<m>:FLXRay:DPTO](#).

*RST: EQUAL

TRIGger<m>:FLXRay:DPOsition <DataPosition>

Sets the number of data bytes to be skipped after start of the payload segment

Suffix:

<m> 1..3
Event in a trigger sequence: 1 = A-event only

Parameters:

<DataPosition> Range: 0 to 255
Increment: 1
*RST: 0

TRIGger<m>:FLXRay:DPTO <DataPositionTo>

Defines the last byte of interest, if the position operator [TRIGger<m>:FLXRay:DPOperator](#) defines a range.

Suffix:

<m> 1..3
Event in a trigger sequence: 1 = A-event only

Parameters:

<DataPositionTo> Range: 0 to 255
Increment: 1
*RST: 0

TRIGger<m>:FLXRay:DCONDition <DataOperator>

Sets the operator to set a specific data pattern or a data pattern range.

Suffix:

<m> 1..3
Event in a trigger sequence: 1 = A-event only

Parameters:

<DataOperator> OFF | EQUal | NEQual | LTHan | LETHan | GTHan | GETHan | INRange | OORange

OFF

The data position is not relevant for the trigger condition.

EQUal | NEQual | LTHan | LETHan | GTHan | GETHan

Equal, Not equal, Less than, Less or equal than, Greater Than, Greater or equal than. These conditions require one data position to be set with [TRIGger<m>:FLXRay:DMIN](#).

INRange | OORange

In range / Out of range: Set the minimum and maximum value of the range with [TRIGger<m>:FLXRay:DMIN](#) and [TRIGger<m>:FLXRay:DMAX](#).

*RST: EQUal

TRIGger<m>:FLXRay:DMIN <DataPattern>

Specifies a data pattern, or sets the the start value of a data pattern range.

Suffix:

<m> 1..3
Event in a trigger sequence: 1 = A-event only

Parameters:

<DataPattern> Numeric or string pattern, see [chapter 21.2.3.6, "Bit Pattern Parameter"](#), on page 667. The string parameter accepts the bit value X (don't care).

TRIGger<m>:FLXRay:DMAX <DataPatternTo>

Sets the the end value of an data range if the operator `TRIGger<m>:FLXRay:DCONdition` is set to `INRange` or `OORange`.

Suffix:

<m> 1..3
Event in a trigger sequence: 1 = A-event only

Parameters:

<DataPatternTo> Numeric or string pattern, see [chapter 21.2.3.6, "Bit Pattern Parameter"](#), on page 667. The string parameter accepts the bit value X (don't care).

TRIGger<m>:FLXRay:SYMBOL <Symbol>

Triggers on a symbol or on a wakeup pattern.

Suffix:

<m> 1..3
Event in a trigger sequence: 1 = A-event only

Parameters:

<Symbol> CASMts | WAKEup

CASMts

Collision Avoidance Symbol / Media access Test Symbol. These symbols are identical and can be sent in the optional symbol window at the end of a communication cycle. They are used to avoid collisions during the system start.

WAKEup

The wakeup pattern is sent to activate the nodes of the system.

*RST: CASMts

TRIGger<m>:FLXRay:BSSerror <BSSError>

Triggers on error in SyteStart Sequence. The BSS is transmitted before each byte.

Suffix:

<m> 1..3
Event in a trigger sequence: 1 = A-event only

Parameters:

<BSSError> ON | OFF
*RST: ON

TRIGger<m>:FLXRay:FESerror <FESerror>

Triggers on error in Frame End Sequence. FES indicates the end of each frame.

Suffix:

<m> 1..3
Event in a trigger sequence: 1 = A-event only

Parameters:

<FESerror> ON | OFF
*RST: ON

TRIGger<m>:FLXRay:FSSerror <FSSerror>

Triggers on Error in a Frame Start Sequence. FSS follows the Transmission Start Sequence TSS at the beginning of each frame.

Suffix:

<m> 1..3
Event in a trigger sequence: 1 = A-event only

Parameters:

<FSSerror> ON | OFF
*RST: ON

TRIGger<m>:FLXRay:HRCerror <CRCHerror>

Triggers on error in the Cyclic Redundancy Check of the header data (mainly frame ID and payload length).

Suffix:

<m> 1..3
Event in a trigger sequence: 1 = A-event only

Parameters:

<CRCHerror> ON | OFF
*RST: ON

TRIGger<m>:FLXRay:PCRCerror <CRCPerror>

Triggers on error in the Cyclic Redundancy Check of the payload data.

Suffix:

<m> 1..3
Event in a trigger sequence: 1 = A-event only

Parameters:

<CRCPayloadError> ON | OFF
*RST: ON

FlexRay Decoding Results

BUS<m>:FLXRay:FCOunt?	1027
BUS<m>:FLXRay:FRAMe<n>:STATus?	1027
BUS<m>:FLXRay:FRAMe<n>:STARt?	1028
BUS<m>:FLXRay:FRAMe<n>:STOP?	1028
BUS<m>:FLXRay:FRAMe<n>:TYPE?	1028
BUS<m>:FLXRay:FRAMe<n>:DATA?	1029
BUS<m>:FLXRay:FRAMe<n>:FLAGs?	1029
BUS<m>:FLXRay:FRAMe<n>:ADID?	1029
BUS<m>:FLXRay:FRAMe<n>:PAYLength?	1030
BUS<m>:FLXRay:FRAMe<n>:CYCount?	1030
BUS<m>:FLXRay:FRAMe<n>:CSState?	1030
BUS<m>:FLXRay:FRAMe<n>:CSValue?	1031
BUS<m>:FLXRay:FRAMe<n>:FCState?	1031
BUS<m>:FLXRay:FRAMe<n>:FCValue?	1032

BUS<m>:FLXRay:FCOunt?

Returns the number of decoded frames.

Suffix:

<m> 1..4
Selects the serial bus.

Return values:

<Count> Returns the number of decoded frames.

Usage: Query only

BUS<m>:FLXRay:FRAMe<n>:STATus?

Returns the overall state of the selected frame.

Suffix:

<m> 1..4
Selects the serial bus.

<n> *
Selects the frame.

Return values:

<FrameState> OK | FSS | BSS | FES | INDicator | HRCError | CRCerr | LENER | WAKEup | MTS | INSufficient

OK: the frame is valid.
 FSS: Frame Start Sequence after TSS is missing.
 BSS: Byte Start Sequence is missing.
 FES: error in the Frame End Sequence.
 INDicator: Error in indicator bits.
 HRCError: Header CRC is not valid.
 CRCerr: Payload CRC is not valid.
 LENER: Unexpected length of the frame.
 WAKEup: frame contains a wakeup pattern.
 MTS: frame contains a MTS or CAS symbol
 INSufficient: The frame is not completely contained in the acquisition. The acquired part of the frame is valid.

*RST: OK

Usage: Query only

BUS<m>:FLXRay:FRAMe<n>:START?**BUS<m>:FLXRay:FRAMe<n>:STOP?**

Return the start time and stop time of the selected frame.

Suffix:

<m> 1..4
 Selects the serial bus.

<n> *
 Selects the frame.

Return values:

<FrameStart> Time

<FrameStop> Range: -100E+24 to 100E+24
 *RST: 0
 Default unit: s

Usage: Query only

BUS<m>:FLXRay:FRAMe<n>:TYPE?

Returns the frame type of the selected frame.

Suffix:

<m> 1..4
 Selects the serial bus.

<n> *
 Selects the frame.

Return values:

<FrameType> UNKNown | STATic | DYNamic | WAKE | SYMBol
 STATic: frame of the static segment
 DYNamic: frame of the dynamic segment
 WAKE: frame contains wakeup pattern
 SYMBol: frame contains a MTS or CAS symbol
 *RST: STATic

Usage: Query only

BUS<m>:FLXRaY:FRAMe<n>:DATA?

Returns the data bytes of the specified frame.

Suffix:

<m> 1..4
 Selects the serial bus.
 <n> *
 Selects the frame.

Return values:

<Data> Comma-separated list of values. To set the value format, use [FORMat:BPATtern](#).

Usage: Query only

BUS<m>:FLXRaY:FRAMe<n>:FLAGs?

Returns the value of the indicator bits at the beginning of the header segment. The five bits are read as one word.

Suffix:

<m> 1..4
 Selects the serial bus.
 <n> *
 Selects the frame.

Return values:

<IndicatorBits> Range: 0 to 31
 *RST: 0

Usage: Query only

BUS<m>:FLXRaY:FRAMe<n>:ADID?

Returns the frame identifier, the number of the slot in which the frame is transmitted.

Suffix:

<m> 1..4
 Selects the serial bus.

<n> *
Selects the frame.

Return values:

<FrameIDvalue> To set the value format, use [FORMat:BPATtern](#) on page 674. The values below – range, increment and default – are decimal values.

Range: 0 to 2047

*RST: 0

Usage: Query only

BUS<m>:FLXRay:FRAMe<n>:PAYLength?

Returns the payload length, the number of data words in the payload segment. Information is transmitted in 2-byte words, so the number of data bytes in the payload segment is twice the payload length.

Suffix:

<m> 1..4
Selects the serial bus.

<n> *
Selects the frame.

Return values:

<Value> Range: 0 to 127
*RST: 0

Usage: Query only

BUS<m>:FLXRay:FRAMe<n>:CYCount?

Returns the number of the current FlexRay cycle.

Suffix:

<m> 1..4
Selects the serial bus.

<n> *
Selects the frame.

Return values:

<CycleCount> Range: 0 to 63
*RST: 0

Usage: Query only

BUS<m>:FLXRay:FRAMe<n>:CSState?

Returns the state of the cyclic redundancy check code of the header data.

Suffix:

<m>	1..4 Selects the serial bus.
<n>	* Selects the frame.

Return values:

<HeaderCRCstate>	OK UVAL INSufficient OK: the CRC is valid. UVAL: unexpected value INSufficient: the frame is not completely contained in the acquisition. The decoded part of the frame is valid.
*RST:	OK

Usage: Query only

BUS<m>:FLXRay:FRAME<n>:CSValue?

Returns the checksum value of the header CRC.

Suffix:

<m>	1..4 Selects the serial bus.
<n>	* Selects the frame.

Return values:

<HeaderCRCvalue>	To set the value format, use FORMat:BPATtern on page 674. The values below – range, increment and default – are decimal values. Range: 0 to 2047 *RST: 0
------------------	--

Usage: Query only

BUS<m>:FLXRay:FRAME<n>:FCState?

Returns the state of the cyclic redundancy check code of the frame data.

Suffix:

<m>	1..4 Selects the serial bus.
<n>	* Selects the frame.

Return values:

<FrameCRCstate> OK | UVAL | INSufficient
 OK: the CRC is valid.
 UVAL: unexpected value
 INSufficient: the frame is not completely contained in the acquisition. The decoded part of the frame is valid.
 *RST: OK

Usage: Query only

BUS<m>:FLXRay:FRAMe<n>:FCValue?

Returns the cyclic redundancy check code of the frame CRC.

Suffix:

<m> 1..4
 Selects the serial bus.

<n> *
 Selects the frame.

Return values:

<FrameCRCvalue> To set the value format, use [FORMat:BPATtern](#) on page 674. The values below – range, increment and default – are decimal values.

Range: 0 to 16777215
 *RST: 0

Usage: Query only

Label List

[BUS<m>:SYMBols](#)..... 1032
[BUS<m>:FLXRay:FRAMe<n>:SYMBol?](#)..... 1033

BUS<m>:SYMBols <UseTranslation>

Activates the lable list to be used for decoding.

Suffix:

<m> 1..4
 Selects the serial bus.

Parameters:

<UseTranslation> ON | OFF
 *RST: OFF

Usage: Asynchronous command

Firmware/Software: FW 1.36

BUS<m>:FLXRay:FRAMe<n>:SYMBol?

Returns the symbolic label of the specified frame if the label list is enabled.

Suffix:

<m>	1..4 Selects the serial bus.
<n>	* Selects the number of the frame in the current acquisition, 1...n.

Return values:

<Label> String with symbolic name of the identifier

Example:

BUS:FLXRay:FRAME2:SYMBOL?

Response: Temperature

Usage:

Query only

Firmware/Software: FW 1.36

21.2.17.8 Audio Signals (Option R&S RTO-K5)

- [Audio Signal Configuration](#)..... 1033
- [Audio Trigger](#)..... 1039
- [Audio Decode Results](#)..... 1043
- [Track and Trend](#)..... 1046

Audio Signal Configuration

BUS<m>:I2S:AVARiant	1033
BUS<m>:I2S:CLOCK:SOURce	1034
BUS<m>:I2S:CLOCK:POLarity	1034
BUS<m>:I2S:WSElect:SOURce	1034
BUS<m>:I2S:WSElect:POLarity	1035
BUS<m>:I2S:DATA:SOURce	1035
BUS<m>:I2S:DATA:POLarity	1036
BUS<m>:I2S:TCoupling	1036
BUS<m>:I2S:CLOCK:THReshold	1036
BUS<m>:I2S:WSElect:THReshold	1036
BUS<m>:I2S:DATA:THReshold	1037
BUS<m>:I2S:CHANnel:ORDer	1037
BUS<m>:I2S:WLENgth	1037
BUS<m>:I2S:BORDer	1038
BUS<m>:I2S:CHANnel:OFFSet	1038
BUS<m>:I2S:CHANnel:TDMCount	1038
BUS<m>:I2S:FOFFset	1038
BUS<m>:I2S:CHANnel:LENgth	1039

BUS<m>:I2S:AVARiant <AudioVariant>

Selects the audio signal type.

For details, see "[Audio Variant](#)" on page 493.

Suffix:

<m> 1..4
Selects the serial bus.

Parameters:

<AudioVariant> I2S | LJ | RJ | TDM
I2S: Inter-IC Sound standard audio format.
LJ: left-justified data format
RJ: right-justified data format
TDM: Time Division Multiplexed audio format
*RST: I2S

BUS<m>:I2S:CLOCK:SOURce <I2SSettingsSCLK>

Selects the source of the clock line.

Suffix:

<m> 1..4
Selects the serial bus.

Parameters:

<I2SSettingsSCLK> C1W1 | C2W1 | C3W1 | C4W1 | M1 | M2 | M3 | M4 | R1 | R2 |
R3 | R4 | D0 | D1 | D2 | D3 | D4 | D5 | D6 | D7 | D8 | D9 | D10 |
D11 | D12 | D13 | D14 | D15
Digital channels require installation of R&S RTO-B1. Digital and
analog channels cannot be used at the same time. For triggering
on a serial bus, analog or digital input channels are required.
*RST: C1W1

BUS<m>:I2S:CLOCK:POLarity <BitClockEdge>

Sets the polarity of the clock signal, that is the edge at which the instrument samples
the data on the data line.

Suffix:

<m> 1..4
Selects the serial bus.

Parameters:

<BitClockEdge> FALLing | RISing
*RST: RISing

BUS<m>:I2S:WSElect:SOURce <I2SSettingsWS>

Selects the source of the word select line for I²S standard, left- und right-justified data
formats, or the source of the frame synchronization pulse for TDM audio signals.

Suffix:

<m> 1..4
Selects the serial bus.

Parameters:

<l2SSettingsWS> C1W1 | C2W1 | C3W1 | C4W1 | M1 | M2 | M3 | M4 | R1 | R2 |
R3 | R4 | D0 | D1 | D2 | D3 | D4 | D5 | D6 | D7 | D8 | D9 | D10 |
D11 | D12 | D13 | D14 | D15

Digital channels require installation of R&S RTO-B1. Digital and analog channels cannot be used at the same time. For triggering on a serial bus, analog or digital input channels are required.

*RST: C1W1

BUS<m>:l2S:WSElect:POLarity <WSPolarity>

For a word select line, the polarity defines the signal values assigned to the left and right channels.

For an FSYNC line (TDM), the polarity defines the edge of the FSYNC pulse that identifies the beginning of a frame.

Suffix:

<m> 1..4
Selects the serial bus.

Parameters:

<WSPolarity> NORMal | INVert
NORMal: 0 = left, 1 = right channel; or rising edge for TDM
INVert: 1= left, 0 = right channel; or falling edge for TDM

*RST: NORMal

BUS<m>:l2S:DATA:SOURce <l2SSettingsSDAT>

Selects the source of the audio data line.

Suffix:

<m> 1..4
Selects the serial bus.

Parameters:

<l2SSettingsSDAT> C1W1 | C2W1 | C3W1 | C4W1 | M1 | M2 | M3 | M4 | R1 | R2 |
R3 | R4 | D0 | D1 | D2 | D3 | D4 | D5 | D6 | D7 | D8 | D9 | D10 |
D11 | D12 | D13 | D14 | D15

Digital channels require installation of R&S RTO-B1. Digital and analog channels cannot be used at the same time. For triggering on a serial bus, analog or digital input channels are required.

*RST: C1W1

BUS<m>:I2S:DATA:POLarity <SDataPolarity>

Defines the interpretation of high and low signal states on the data line.

Suffix:

<m> 1..4
Selects the serial bus.

Parameters:

<SDataPolarity> ACTLow | ACTHigh
ACTHigh: HIGH = 1 and LOW = 0
ACTLow: HIGH = 0 and LOW = 1
*RST: ACTHigh

BUS<m>:I2S:TCOupling <Coupling>

Sets all thresholds to the value of the clock threshold [BUS<m>:I2S:CLOCK:THReshold](#).

Suffix:

<m> 1..4
Selects the serial bus.

Parameters:

<Coupling> ON | OFF
*RST: ON

BUS<m>:I2S:CLOCK:THReshold <SCLKThreshold>

Sets the threshold value for the clock line SCLK.

If [BUS<m>:I2S:TCOupling](#) is ON, the command sets the threshold for all lines.

Suffix:

<m> 1..4
Selects the serial bus.

Parameters:

<SCLKThreshold> Range: -10 to 10
Increment: 1E-3
*RST: 1.6
Default unit: V

BUS<m>:I2S:WSElect:THReshold <WSThreshold>

Sets the threshold value for the word select and FSYNC lines.

Suffix:

<m> 1..4
Selects the serial bus.

Parameters:

<WSThreshold> Range: -10 to 10
 Increment: 1E-3
 *RST: 1.6
 Default unit: V

BUS<m>:I2S:DATA:THReshold <SDATAThreshold>

Sets the threshold value for the data line.

Suffix:

<m> 1..4
 Selects the serial bus.

Parameters:

<SDATAThreshold> Range: -10 to 10
 Increment: 1E-3
 *RST: 1.6
 Default unit: V

BUS<m>:I2S:CHANnel:ORDer <ChannelOrder>

Defines if the left or the right channel is the first channel in the frame.

The setting is not available for TDM audio signals.

Suffix:

<m> 1..4
 Selects the serial bus.

Parameters:

<ChannelOrder> LFIRst | RFIRst
 Left channel first or right first
 *RST: LFIRst

BUS<m>:I2S:WLENgth <WordLength>

Defines the number of bits in an audio data word.

Suffix:

<m> 1..4
 Selects the serial bus.

Parameters:

<WordLength> Range: 4 to 32
 Increment: 4
 *RST: 8
 Default unit: bit

BUS<m>:I2S:BORDER <BitOrder>

Sets the bit order of the audio data words.

Suffix:

<m> 1..4
Selects the serial bus.

Parameters:

<BitOrder> LSBF | MSBF
LSB first or MSB first
*RST: MSBF

BUS<m>:I2S:CHANnel:OFFSet <ChannelOffset>

Sets the number of bits between the channel start and the start of the audio word.

Suffix:

<m> 1..4
Selects the serial bus.

Parameters:

<ChannelOffset> Range: 0 to 32 (left-justified). TDM: maximum delay is
Channel length - Word length
Increment: 1
*RST: 0
Default unit: bit

BUS<m>:I2S:CHANnel:TDMCount <ChannelsTDM>

Sets the number of channels transmitted on the TDM audio line.

Suffix:

<m> 1..4
Selects the serial bus.

Parameters:

<ChannelsTDM> Range: 1 to 8
Increment: 1
*RST: 1

BUS<m>:I2S:FOFFset <FrameOffsetTDM>

Sets the number of bits between the frame start and the start of the first channel of a TDM audio line. Each FSYNC edge restarts the offset count.

Suffix:

<m> 1..4
Selects the serial bus.

Parameters:

<FrameOffsetTDM> Range: 0 to 256
 Increment: 1
 *RST: 0
 Default unit: bit

BUS<m>:I2S:CHANnel:LENGth <ChLengthTDM>

Sets the number of bits in a TDM channel block.

Suffix:

<m> 1..4
 Selects the serial bus.

Parameters:

<ChLengthTDM> Range: 4 to 32
 Increment: 4
 *RST: 8
 Default unit: bit

Audio Trigger

TRIGger<m>:I2S:TYPE.....	1039
TRIGger<m>:I2S:TCONdition<n>:CHANnel.....	1040
TRIGger<m>:I2S:TCONdition<n>:CONDtion.....	1041
TRIGger<m>:I2S:TCONdition<n>:DMIN.....	1042
TRIGger<m>:I2S:TCONdition<n>:DMAX.....	1042
TRIGger<m>:I2S:SOWords.....	1043
TRIGger<m>:I2S:WSSlope.....	1043

TRIGger<m>:I2S:TYPE <Type>

Selects the trigger type for audio signal analysis.

Suffix:

<m> 1..3
 Event in a trigger sequence: 1 = A-event only

Parameters:

<Type>

DATA | WINDow | CONDition | WSElect | ECONdition

DATA

Triggers on a data word or data range on a specified channel or on any channel.

To set the channel, use `TRIGger<m>:I2S:TCONdition<n>:CHANnel`.

To set the data condition, use:

`TRIGger<m>:I2S:TCONdition<n>:CONDtion`,

`TRIGger<m>:I2S:TCONdition<n>:DMIN` and `TRIGger<m>:I2S:TCONdition<n>:DMAX`.

WINDow

Triggers if the decoded data values stay inside a "window" that is formed by a data range and a time specified by a number of subsequent words. It considers a selected channel or all channels.

To set up a window trigger, you define the channel and data condition in the same way as for DATA trigger type. Additionally, you set the time limit with `TRIGger<m>:I2S:SOWords`.

CONDition

The frame condition trigger sets the trigger on an AND combination of data conditions on different channels. The instrument triggers if all conditions are met inside one frame.

To set up a CONDition trigger, you define up to four channel and data conditions in the same way as for DATA trigger type.

WSElect

WordSElect: Triggers on the selected edge of the WS line (I²S standard, left- and right-justified). For TDM signals, it triggers on the selected edge of the FSYNC line. Set the edge with `TRIGger<m>:I2S:WSSlope`.

ECONdition

ErrorCONDition: Triggers on irregularities between the WS or FSYNC edges.

*RST: DATA

Usage:

Asynchronous command

TRIGger<m>:I2S:TCONdition<n>:CHANnel <Channel>

Selects the audio channel on which the instrument looks for the specified data condition.

Suffix:

<m>

1..3

Event in a trigger sequence: 1 = A-event only

<n>	1..4 1 if trigger type is DATA or WINDow Specifies the condition number if trigger type is CONDition: – 1 2 for I ² S standard, left- und right-justified data formats – 1 2 3 4 for TDM signals
Parameters:	
<Channel>	ANY TDMCh1 TDMCh2 TDMCh3 TDMCh4 TDMCh5 TDMCh6 TDMCh7 TDMCh8 LEFT RIGHT ANY The instrument triggers on any channel on which the specified data is found. LEFT RIGHT Available for I ² S Standard, left- und right-justified data formats. TDMCh1 TDMCh2 TDMCh3 TDMCh4 TDMCh5 TDMCh6 TDMCh7 TDMCh8 Available for TDM audio signals Note: Available audio channels depend on the configuration of the audio bus. The command <code>BUS<m>:I2S:CHANnel:TDMCount</code> specifies the number of channels in a TDM frame. *RST: ANY

TRIGger<m>:I2S:TCONdition<n>:CONDtion <DataCondition>

Sets the operator to set a specific data pattern or a data pattern range.

Suffix:

<m>	1..3 Event in a trigger sequence: 1 = A-event only
<n>	1..4 1 if trigger type is DATA or WINDow Specifies the condition number if trigger type is CONDition: – 1 2 for I ² S standard, left- und right-justified data formats – 1 2 3 4 for TDM signals

Parameters:

<DataCondition> OFF | EQUal | NEQual | LTHan | LETHan | GTHan | GETHan | INRange | OORange

OFF
No range is defined.

EQUal | NEQual | LTHan | LETHan | GTHan | GETHan
Equal, Not equal, Less than, Less or equal than, Greater Than, Greater or equal than. These conditions require one data pattern to be set with `TRIGger<m>:I2S:TCONdition<n>:DMIN`.

INRange | OORange
In range / Out of range: Set the minimum and maximum value of the range with `TRIGger<m>:I2S:TCONdition<n>:DMIN` and `TRIGger<m>:I2S:TCONdition<n>:DMAX`.

*RST: OFF

TRIGger<m>:I2S:TCONdition<n>:DMIN <DataMinPattern>

Specifies a data pattern, or sets the the start value of a data pattern range.

Suffix:

<m> 1..3
Event in a trigger sequence: 1 = A-event only

<n> 1..4
1 if trigger type is DATA or WINDow
Specifies the condition number if trigger type is CONDition:
– 1 | 2 for I²S standard, left- und right-justified data formats
– 1 | 2 | 3 | 4 for TDM signals

Parameters:

<DataMinPattern> Numeric pattern in 2's complement format. See also: [chapter 21.2.3.6, "Bit Pattern Parameter"](#), on page 667

TRIGger<m>:I2S:TCONdition<n>:DMAX <DataMaxPattern>

Sets the the end value of an data range if the operator `TRIGger<m>:I2S:TCONdition<n>:CONDtion` is set to `INRange` or `OORange`.

Suffix:

<m> 1..3
Event in a trigger sequence: 1 = A-event only

<n> 1..4
1 if trigger type is DATA or WINDow
Specifies the condition number if trigger type is CONDition:
– 1 | 2 for I²S standard, left- und right-justified data formats
– 1 | 2 | 3 | 4 for TDM signals

Parameters:

<DataMaxPattern> Numeric pattern in 2's complement format. See also: [chapter 21.2.3.6, "Bit Pattern Parameter"](#), on page 667

TRIGger<m>:I2S:SOWords <SequenceOfWords>

Sets the number of words that is used as time limit for the "Window" trigger type. The instrument triggers if the data condition is fulfilled on the same channel for the given number of subsequent frames.

Suffix:

<m> 1..3
Event in a trigger sequence: 1 = A-event only

Parameters:

<SequenceOfWords> Range: 1 to 1000000
Increment: 1
*RST: 1
Default unit: word

Usage: Asynchronous command

TRIGger<m>:I2S:WSSlope <WSSlope>

Sets the edge of the WS or FSYNC signal as trigger condition. The instrument triggers on the first clock edge after the specified edge.

Suffix:

<m> 1..3
Event in a trigger sequence: 1 = A-event only

Parameters:

<WSSlope> POSitive | NEGative
*RST: POSitive

Usage: Asynchronous command

Audio Decode Results

BUS<m>:I2S:FCOut?	1044
BUS<m>:I2S:FRAMe<n>:STATe?	1044
BUS<m>:I2S:FRAMe<n>:STARt?	1044
BUS<m>:I2S:FRAMe<n>:STOP?	1044
BUS<m>:I2S:FRAMe<n>:LEFT:VALue?	1045
BUS<m>:I2S:FRAMe<n>:RIGHT:VALue?	1045
BUS<m>:I2S:FRAMe<n>:LEFT:STATe?	1045
BUS<m>:I2S:FRAMe<n>:RIGHT:STATe?	1045
BUS<m>:I2S:FRAMe<n>:TDM<o>:STATe?	1045
BUS<m>:I2S:FRAMe<n>:TDM<o>:VALue?	1046

BUS<m>:I2S:FCOunt?

Returns the number of decoded frames.

Suffix:

<m> 1..4
Selects the serial bus.

Return values:

<Count> Number of decoded audio frames

Usage: Query only

BUS<m>:I2S:FRAMe<n>:STATe?

Returns the overall state of the selected frame.

Suffix:

<m> 1..4
Selects the serial bus.

<n> *
Selects the frame.

Return values:

<FrameState> ERRor | OK | INSufficient
OK: the frame is valid.
ERRor: an error occurred in the frame.
INSufficient: The frame is not completely contained in the acquisition. The acquired part of the frame is valid.

Usage: Query only

BUS<m>:I2S:FRAMe<n>:START?**BUS<m>:I2S:FRAMe<n>:STOP?**

Return the start time and stop time of the selected frame.

Suffix:

<m> 1..4
Selects the serial bus.

<n> *
Selects the frame.

Return values:

<FrameStart> Range: -100E+24 to 100E+24
<FrameStop> *RST: 0

Usage: Query only

BUS<m>:I2S:FRAMe<n>:LEFT:VALue?
BUS<m>:I2S:FRAMe<n>:RIGHT:VALue?

Return the data values of the left and right channel, respectively.

Suffix:

<m>	1..4 Selects the serial bus.
<n>	* Selects the frame.

Return values:

<Value>	Comma-separated list of values. To set the value format, use FORMat:BPATtern .
Range:	0 to 4294967295
*RST:	0

Usage: Query only

BUS<m>:I2S:FRAMe<n>:LEFT:STATe?
BUS<m>:I2S:FRAMe<n>:RIGHT:STATe?

Return the status of the left and right channel of the selected frame.

Suffix:

<m>	1..4 Selects the serial bus.
<n>	* Selects the frame.

Return values:

<WordState>	ERRor OK INSufficient OK: the channel data is valid. ERRor: an error occurred in the channel. INSufficient: the channel is not completely contained in the acquisition.
-------------	--

Usage: Query only

BUS<m>:I2S:FRAMe<n>:TDM<o>:STATe?

Returns the state of the indicated channel of the selected frame.

Suffix:

<m>	1..4 Selects the serial bus.
<n>	* Selects the frame.
<o>	1..8 Selects the TDM channel.

Return values:

<State> ERRor | OK | INSufficient
 OK: the channel data is valid.
 ERRor: an error occurred in the channel.
 INSufficient: the channel is not completely contained in the acquisition.

Usage: Query only

BUS<m>:I2S:FRAMe<n>:TDM<o>:VALue?

Return the data value of the indicated TDM channel.

Suffix:

<m> 1..4
 Selects the serial bus.

<n> *
 Selects the frame.

<o> 1..8
 Selects the TDM channel.

Return values:

<Value> To set the value format, use [FORMat:BPATtern](#) on page 674.
 The values below – range, increment and default – are decimal values.

Usage: Query only

Track and Trend

BUS<m>:I2S:TRACk:LEFt	1046
BUS<m>:I2S:TRACk:RIghT	1046
BUS<m>:I2S:TRACk:TD1Ch	1047
BUS<m>:I2S:TRACk:TD2Ch	1047
BUS<m>:I2S:TRACk:TD3Ch	1047
BUS<m>:I2S:TRACk:TD4Ch	1047
BUS<m>:I2S:TRACk:TD5Ch	1047
BUS<m>:I2S:TRACk:TD6Ch	1047
BUS<m>:I2S:TRACk:TD7Ch	1047
BUS<m>:I2S:TRACk:TD8Ch	1047
MEASurement<m>:TRACk[:STATe]	1047
MEASurement<m>:TRACk:DATA:HEADer?	1047
MEASurement<m>:TRACk:DATA:STYPe?	1048
MEASurement<m>:TRACk:DATA[:VALues]?	1048

BUS<m>:I2S:TRACk:LEFt <Channel>

BUS<m>:I2S:TRACk:RIghT <Channel>

Enables or disables the track of the indicated channel. The commands are relevant for I²S standard, left-justified and right-justified audio data formats.

Suffix:

<m> 1..4
Selects the serial bus.

Parameters:

<Channel> ON | OFF
*RST: OFF

BUS<m>:I2S:TRACk:TD1Ch <TDMCh1>
BUS<m>:I2S:TRACk:TD2Ch <TDMCh2>
BUS<m>:I2S:TRACk:TD3Ch <TDMCh3>
BUS<m>:I2S:TRACk:TD4Ch <TDMCh4>
BUS<m>:I2S:TRACk:TD5Ch <TDMCh5>
BUS<m>:I2S:TRACk:TD6Ch <TDMCh6>
BUS<m>:I2S:TRACk:TD7Ch <TDMCh7>
BUS<m>:I2S:TRACk:TD8Ch <TDMCh8>

Enables or disables the track of the indicated channel. The commands are relevant for TDM audio data.

Suffix:

<m> 1..4
Selects the serial bus.

Parameters:

<TDMChX> ON | OFF
*RST: OFF

MEASurement<m>:TRACk[:STATe] <State>

Enables the track measurement and displays the track.

See also: "[Enable \(Track\)](#)" on page 280

Suffix:

<m> 1..9
See "[Measurement selection: MEASurement<m>](#)" on page 789.

Parameters:

<State> ON | OFF
*RST: OFF

MEASurement<m>:TRACk:DATA:HEADer?

Returns the header of the track.

Suffix:

<m> 1..9
See "[Measurement selection: MEASurement<m>](#)" on page 789.

Usage: Query only

MEASurement<m>:TRACk:DATA:STYPe?

Returns the data type: TRK (track)

Suffix:

<m> 1..9
See "[Measurement selection: MEASurement<m>](#)" on page 789.

Usage: Query only

MEASurement<m>:TRACk:DATA[:VALues]?

Returns the data of track points for transmission from the instrument to the controlling computer. The data can be used in MATLAB, for example.

To set the export format, use `FORMat [: DATA]`.

Suffix:

<m> 1..9
See "[Measurement selection: MEASurement<m>](#)" on page 789.

Usage: Query only

21.2.18 Mixed Signal Option (MSO, R&S RTO-B1)

This chapter describes the remote commands of MSO option R&S RTO-B1.

- [Digital Channels](#)..... 1048
- [Parallel Bus Configuration](#)..... 1051
- [Trigger Settings for Digital Signals and Parallel Buses](#)..... 1058
- [MSO Decoding Results](#)..... 1068

21.2.18.1 Digital Channels

All `DIGital:` commands affect only the settings of the first MSO bus (Bus1). The settings of all other parallel buses (Bus 2, 3,4) remain unchanged.

DIGital<m>:DISPlay	1048
DIGital<m>:TECHnology	1049
DIGital<m>:THReshold	1049
DIGital<m>:THCoupling	1050
DIGital<m>:HYSTeresis	1050
DIGital<m>:LABel	1051
DIGital<m>:DESKew	1051

DIGital<m>:DISPlay <Display>

Enables or disables the indicated digital channel, displays it, and enables the parallel Bus1 if the bus was disabled. That is, `BUS<m>:PARallel:DISPlay:SHDI` and `BUS<m>:PARallel:STATe` are set to ON automatically.

If another active bus already uses the selected digital channel, the instrument disables the other bus to avoid conflicts.

For Bus1, the `DIG:DISP` command has the same effect as `BUS<m>:PARallel:BIT<n>[:STATe]`. To enable digital channels for buses 2, 3 and 4, use the `BUS:PAR:BIT[:STAT]` command.

Suffix:

<m> 0..15
Number of the digital channel

Parameters:

<Display> ON | OFF

Firmware/Software: V 1.30

DIGital<m>:TECHnology <Technology>

Selects the threshold voltage for various types of integrated circuits and applies it to all digital channels.

The setting affects only the settings of the first MSO bus (Bus1). You can set the technology value for all buses with `BUS<m>:PARallel:TECHnology`.

Suffix:

<m> 0..15
The suffix is irrelevant.

Parameters:

<Technology> V15 | V25 | V165 | V125 | V09 | VM13 | V38 | V20 | V0 | MAN
See `BUS<m>:PARallel:TECHnology`

Firmware/Software: V 1.40

DIGital<m>:THReshold <Value>

Sets the logical threshold for the channel group to which the indicated digital channel belongs. The setting affects only the settings of the first MSO bus (Bus1).

The setting affects only the settings of the first MSO bus (Bus1). You can set the threshold for all buses with `BUS<m>:PARallel:TECHnology` or `BUS<m>:PARallel:THReshold<n>`.

See also: `DIGital<m>:THCoupling`

Suffix:

<m> 0..15
Number of the digital channel.
Channel groups: 0..3; 4..7; 8..11; 12..15

Parameters:

<Value> Range: -8.0 to 8.0
 Increment: 200.0e-12
 *RST: 0
 Default unit: V

Firmware/Software: V 1.30

DIGital<m>:THCOupling <State>

Sets the threshold and the hysteresis for all digital channels of parallel bus 1 to the same value.

The command `BUS<m>:PARallel:THCOupling` is used to set all buses.

Suffix:

<m> 0..15
 The suffix is irrelevant.

Parameters:

<State> ON | OFF

Firmware/Software: V 1.30

DIGital<m>:HYSTeresis <Hysteresis>

Defines the size of the hysteresis to avoid the change of signal states due to noise for the channel group to which the indicated digital channel belongs.

The setting affects only the settings of the first MSO bus (Bus1). You can set the hysteresis for all buses with `BUS<m>:PARallel:HYSTeresis<n>`.

See also: [DIGital<m>:THCOupling](#)

Suffix:

<m> 0..15
 Number of the digital channel
 Channel groups: 0..3; 4..7; 8..11; 12..15

Parameters:

<Hysteresis> MAXIMUM | ROBUST | NORMAL

MAXIMUM

Maximum value that is possible and useful for the signal and its settings

ROBUST

Different hysteresis values for falling and rising edges to avoid an undefined state of the trigger system.

NORMAL

The instrument sets a value suitable for the signal and its settings.

Firmware/Software: V 1.30

DIGital<m>:LABel <Label>

Sets a name for the indicated digital channel. The name is displayed in the diagram.

The setting affects only the settings of the first MSO bus (Bus1). You can set the label for all buses with `BUS<m>:PARAllel:BIT<n>:LABel`.

Suffix:

<m> 0..15
Number of the digital channel

Parameters:

<Label> String containing the channel name

Firmware/Software: V 1.30

DIGital<m>:DESKew <Deskew>

Sets an individual delay for each digital channel to time-align it with other digital channels. The deskew value compensates delays that are known from the circuit specifics or caused by the different length of cables.

The setting affects only the settings of the first MSO bus (Bus1). You can set the deskew for all buses with `BUS<m>:PARAllel:BIT<n>:DESKew`.

Suffix:

<m> 0..15
Number of the digital channel

Parameters:

<Deskew> Range: -200.0E-09 to 200.0E-09
Increment: 200.0E-12
*RST: 0
Default unit: s

21.2.18.2 Parallel Bus Configuration

The following commands configure the four parallel buses of R&S RTO-B1.

<code>BUS<m>:PARAllel:STATe</code>	1052
<code>BUS<m>:PARAllel:BIT<n>[:STATe]</code>	1052
<code>BUS<m>:PARAllel:THReshold<n></code>	1052
<code>BUS<m>:PARAllel:TECHnology</code>	1053
<code>BUS<m>:PARAllel:THCoupling</code>	1054
<code>BUS<m>:PARAllel:HYSTeresis<n></code>	1054
<code>BUS<m>:PARAllel:BIT<n>:DESKew</code>	1055
<code>BUS<m>:PARAllel:DESOffset</code>	1055
<code>BUS<m>:PARAllel:BIT<n>:LABel</code>	1055
<code>BUS<m>:PARAllel:DISPlay:SHDI</code>	1056
<code>BUS<m>:PARAllel:DISPlay:SHBU</code>	1056
<code>BUS<m>:PARAllel:DISPlay:BTYP</code>	1056
<code>BUS<m>:PARAllel:CLON</code>	1057

BUS<m>:PARAllel:CLOCK.....	1057
BUS<m>:PARAllel:CLSLope.....	1057
BUS<m>:PARAllel:CLEar.....	1057

BUS<m>:PARAllel:STATe <Enable>

Enables or disables the indicated parallel bus. The threshold settings of the bus take effect for all *active* parallel buses.

Dependencies: At least one digital channel must be enabled for the selected bus, otherwise the command does not work. The bus is enabled automatically if the first digital channel is enabled with `BUS<m>:PARAllel:BIT<n>[:STATe]` or `DIGital<m>:DISPlay`.

Suffix:

<m> 1..4
Selects the parallel bus.

Parameters:

<Enable> ON | OFF
*RST: OFF

Firmware/Software: V 1.30

BUS<m>:PARAllel:BIT<n>[:STATe] <Assigned>

Assigns the selected digital channel to the indicated bus, displays it, and enables the bus if the bus was disabled. That is, `BUS<m>:PARAllel:DISPlay:SHDI` and `BUS<m>:PARAllel:STATe` are set to ON automatically.

If another active bus already uses the selected digital channel, the instrument disables the other bus to avoid conflicts.

For parallel bus 1, the `BUS:PAR:BIT[:STATe]` command has the same effect as `DIGital<m>:DISPlay`.

Suffix:

<m> 1..4
Selects the parallel bus.

<n> 0..15
Selects the digital channel. Each digital channel provides a definite bit of the bus word.

Parameters:

<Assigned> ON | OFF
*RST: OFF

Firmware/Software: V 1.40

BUS<m>:PARAllel:THReshold<n> <Threshold>

Sets the logical threshold for the indicated channel group.

Alternatively, you can set the threshold with `BUS<m>:PARAllel:TECHnology`. For the parallel bus 1, you can also use `DIGital<m>:THReshold`.

See also: `DIGital<m>:THCoupling`

Suffix:

`<m>` 1..4
Selects the parallel bus.

`<n>` 1..4
Selects the channel group:
1 = dig. channels 0..3;
2 = dig. channels 4..7
3 = dig. channels 8..11
4 = dig. channels 12..15

Parameters:

`<Threshold>` Range: -8.0 to 8.0
Increment: 200.0e-12
*RST: 0
Default unit: V

Firmware/Software: V 1.40

BUS<m>:PARAllel:TECHnology <Technology>

Selects the threshold voltage for various types of integrated circuits and applies it to all digital channels.

Suffix:

`<m>` 1..4
Selects the parallel bus.

Parameters:

`<Technology>` V15 | V25 | V165 | V125 | V09 | VM13 | V38 | V20 | V0 | MAN
V15: TTL
V25: CMOS 5.0 V
V165: CMOS 3.3 V
V125: CMOS 2.5 V
V09: CMOS 1.85 V
VM13: ECL, -1.3 V
V38: PECL
V20: LVPECL
V0: Ground
MAN: Set a user-defined threshold value with `DIGital<m>:THReshold`
*RST: V165

Usage: SCPI confirmed

Firmware/Software: V 1.36

BUS<m>:PARAllel:THCOUpling <LevelCoupling>

Sets the threshold for all digital channels of the selected bus to the same value. Also the hysteresis value is applied to all digital channels.

For parallel bus 1, the command `DIGital<m>:THCOUpling` has the same effect.

Suffix:

<m> 1..4
The suffix is irrelevant.

Parameters:

<LevelCoupling> ON | OFF
*RST: ON

Firmware/Software: V 1.30

BUS<m>:PARAllel:HYSTEResis<n> <Hysteresis>

Defines the size of the hysteresis for the channel group to avoid the change of signal states due to noise.

For the parallel bus 1, you can also use `DIGital<m>:HYSTEResis`.

Suffix:

<m> 1..4
Selects the parallel bus.

<n> 1..4
Selects the channel group:
1 = dig. channels 0..3;
2 = dig. channels 4..7
3 = dig. channels 8..11
4 = dig. channels 12..15

Parameters:

<Hysteresis> MAXIMUM | ROBUST | NORMAL

MAXIMUM

Maximum value that is possible and useful for the signal and its settings

ROBUST

Different hysteresis values for falling and rising edges to avoid an undefined state of the trigger system.

NORMAL

The instrument sets a value suitable for the signal and its settings.

Firmware/Software: V 1.40

BUS<m>:PARAllel:BIT<n>:DESKew <Deskew>

Sets an individual delay for each digital channel to time-align it with other digital channels. The deskew value compensates delays that are known from the circuit specifics or caused by the different length of cables.

For the parallel bus 1, you can also use [DIGital<m>:DESKew](#).

Suffix:

<m>	1..4	Selects the parallel bus.
<n>	0..15	Number of the digital channel

Parameters:

<Deskew>	Range: -200E-9 to 200E-9
	Increment: 200E-12
	*RST: 0
	Default unit: s

BUS<m>:PARAllel:DESoffset <DeskewOffset>

Sets a general delay for all digital channels. The resulting deskew of a digital channel is the sum of this general value and the individual value set with [BUS<m>:PARAllel:BIT<n>:DESKew](#).

Suffix:

<m>	1..4	Selects the parallel bus.
-----	------	---------------------------

Parameters:

<DeskewOffset>	Range: -200E-9 to 200E-9
	Increment: 200E-12
	*RST: 0
	Default unit: s

BUS<m>:PARAllel:BIT<n>:LABel <Label>

Sets a name for the indicated digital channel. The name is displayed in the diagram.

For the parallel bus 1, you can also use [DIGital<m>:LABel](#).

Suffix:

<m>	1..4	Selects the parallel bus.
<n>	0..15	Number of the digital channel

Parameters:

<Label>	String containing the channel name
---------	------------------------------------

Firmware/Software: V 1.40

BUS<m>:PARAllel:DISPlay:SHDI <ShowDigitalSigns>

If enabled, the selected digital signals are shown in the diagram. Each channel is displayed as a logic signal.

See also: [DIGital<m>:DISPlay](#)

Suffix:

<m> 1..4
Selects the parallel bus.

Parameters:

<ShowDigitalSigns> ON | OFF
*RST: OFF

Firmware/Software: V 1.30

BUS<m>:PARAllel:DISPlay:SHBU <ShowBus>

Shows or hides the indicated parallel bus. If enabled, the resulting bus signal and bus values are displayed in the diagram.

Suffix:

<m> 1..4
Selects the parallel bus.

Parameters:

<ShowBus> ON | OFF
*RST: OFF

Firmware/Software: V 1.30

BUS<m>:PARAllel:DISPlay:BTYP <BusRepresentation>

Selects the display type of the indicated parallel bus.

Suffix:

<m> 1..4
Selects the parallel bus.

Parameters:

<BusRepresentation> COMB | ANALog

COMB

Displays the decoded bus signal with bus values.

ANALog

Displays the bus value as amplitude, similar to an analog waveform.

*RST: COMB

Firmware/Software: V 1.30

BUS<m>:PARAllel:CLON <Clocked>

Defines if the bus is a clocked bus - one of the digital channels serves as clock of the bus.

Suffix:

<m> 1 | 2
Selects the parallel bus. The clocked bus is available on parallel buses 1 and 2.

Parameters:

<Clocked> ON | OFF
*RST: OFF

Firmware/Software: V 1.36

BUS<m>:PARAllel:CLOCK <ClockSource>

Selects the digital channel used as clock of the indicated parallel bus.

Suffix:

<m> 1 | 2
Selects the parallel bus. The clocked bus is available on parallel buses 1 and 2.

Parameters:

<ClockSource> D0 | D1 | D2 | D3 | D4 | D5 | D6 | D7 | D8 | D9 | D10 | D11 | D12 | D13 | D14 | D15
Clock channel
*RST: D1

Firmware/Software: V 1.30

BUS<m>:PARAllel:CLSlope <ClockSlope>

Selects the slope of the clock signal at which all digital channels of the bus are analyzed.

Suffix:

<m> 1 | 2
Selects the parallel bus. The clocked bus is available on parallel buses 1 and 2.

Parameters:

<ClockSlope> POSitive | NEGative | EITHER
*RST: POSitive

Firmware/Software: V 1.36

BUS<m>:PARAllel:CLEar

Removes all assigned digital channels from the bus

Suffix:
 <m> 1..4
 Selects the parallel bus.

Usage: Event

Firmware/Software: V 1.30

21.2.18.3 Trigger Settings for Digital Signals and Parallel Buses

• General Commands	1058
• Edge Trigger	1060
• Width Trigger	1060
• Timeout Trigger	1062
• Data2Clock Trigger	1063
• State Trigger	1064
• Pattern Trigger	1065
• Serial Pattern Trigger	1068

General Commands

TRIGger<m>:SOURce	1058
TRIGger<m>:PARAllel:TYPE	1059
TRIGger<m>:PARAllel:DATatoclock:CSOURce:VALue	1059
TRIGger<m>:PARAllel:STATe:CSOURce:VALue	1059
TRIGger<m>:PARAllel:SPATtern:CSOURce:VALue	1059
TRIGger<m>:PARAllel:EDGE:EXPRession[:DEFine]	1060
TRIGger<m>:PARAllel:WIDTh:EXPRession[:DEFine]	1060
TRIGger<m>:PARAllel:TIMeout:EXPRession[:DEFine]	1060
TRIGger<m>:PARAllel:STATe:EXPRession[:DEFine]	1060
TRIGger<m>:PARAllel:PATTern:EXPRession[:DEFine]	1060
TRIGger<m>:PARAllel:SPATtern:EXPRession[:DEFine]	1060

TRIGger<m>:SOURce <SourceDetailed>

Selects the source of the trigger signal.

Suffix:
 <m> 1..3
 Event in a trigger sequence: 1 = A-event, 2 = B-event, 3 = R-event.
 Available values depend on the selected trigger source. For input channels CHAN1...4, a trigger sequence can be configured, and suffix values 1, 2, and 3 are allowed.
 For all other trigger sources, only suffix 1 is allowed.
 See also: [TRIGger<m>:SEquence:MODE](#)

Parameters:

<SourceDetailed> CHAN1 | CHAN2 | CHAN3 | CHAN4 | EXTErnalog | SBUS |
 D0 | D1 | D2 | D3 | D4 | D5 | D6 | D7 | D8 | D9 | D10 | D11 | D12 |
 D13 | D14 | D15 | LOGIC | MSOB1 | MSOB2 | MSOB3 | MSOB4

CHAN1...CHAN4
 Input channels

EXTErnalog
 External analog signal connected to the External Trigger Input on the rear panel. For this source, only the analog edge trigger is available.

SBUS
 Serial bus

D0...D15
 Digital channels (option R&S RTO-B1)
 See also: [chapter 21.2.18.3, "Trigger Settings for Digital Signals and Parallel Buses"](#), on page 1058

LOGic
 Logic combination of digital channels, used as trigger source (option R&S RTO-B1)

MSOB1 | MSOB2 | MSOB3 | MSOB4
 Parallel bus (option R&S RTO-B1)

*RST: CHAN1

TRIGger<m>:PARAllel:TYPE <Type>

Selects the trigger type to trigger on digital channels and parallel buses.

To trigger on analog channels or the external trigger input, use [TRIGger<m>:TYPE](#).

Suffix:

<m> 1..3
 Event in a trigger sequence: 1 = A-event only

Parameters:

<Type> EDGE | WIDTH | TIMEout | DATatoclock | STATE | PATTErn |
 SERPattern

*RST: EDGE

TRIGger<m>:PARAllel:DATatoclock:CSOURCE[:VALue] <ClockSource>

TRIGger<m>:PARAllel:STATE:CSOURCE:VALue <ClockSource>

TRIGger<m>:PARAllel:SPATTErn:CSOURCE[:VALue] <ClockSource>

Selects the digital channel of the clock signal.

Suffix:

<m> 1..3
 Event in a trigger sequence: 1 = A-event only

Parameters:

<ClockSource> D0 | D1 | D2 | D3 | D4 | D5 | D6 | D7 | D8 | D9 | D10 | D11 | D12 |
D13 | D14 | D15
*RST: D0

TRIGger<m>:PARAllel:EDGE:EXPRession[:DEFine] <LogicalExpr>
TRIGger<m>:PARAllel:WIDTh:EXPRession[:DEFine] <LogicalExpr>
TRIGger<m>:PARAllel:TIMEout:EXPRession[:DEFine] <LogicalExpr>
TRIGger<m>:PARAllel:STATe:EXPRession[:DEFine] <LogicalExprSigns>
TRIGger<m>:PARAllel:PATtern:EXPRession[:DEFine] <LogicalExprSigns>
TRIGger<m>:PARAllel:SPATtern:EXPRession[:DEFine] <LogicalExpr>

Defines a logical combination of several digital channels as trigger condition if [TRIGger<m>:SOURce](#) is set to LOGIC.

Suffix:

<m> 1..3
Event in a trigger sequence: 1 = A-event only

Parameters:

<LogicalExpr> String with logical expression

Example: TRIGger:PARAllel:EDGE:EXPRession 'D1 and D2'

Usage: SCPI confirmed

Edge Trigger

See also:

- [TRIGger<m>:PARAllel:EDGE:EXPRession\[:DEFine\]](#) on page 1060
- [TRIGger<m>:PARAllel:EDGE:SLOPe](#).....1060

TRIGger<m>:PARAllel:EDGE:SLOPe <Slope>

Defines the edge - the state transition - of the signal to trigger on a single digital channel (a logic bit), or a logical combination of digital channels.

Suffix:

<m> 1..3
Event in a trigger sequence: 1 = A-event only

Parameters:

<Slope> POSitive | NEGative | EITHer
*RST: POSitive

Width Trigger

See also:

- [TRIGger<m>:PARAllel:WIDTh:EXPRession\[:DEFine\]](#) on page 1060

TRIGger<m>:PARAllel:WIDTh:POLarity.....	1061
TRIGger<m>:PARAllel:WIDTh:RANGe.....	1061
TRIGger<m>:PARAllel:WIDTh:WIDTh.....	1061
TRIGger<m>:PARAllel:WIDTh:DELTA.....	1062

TRIGger<m>:PARAllel:WIDTh:POLarity <Polarity>

Sets the polarity of a pulse. When triggering on a positive pulse, the trigger event occurs on the high to low transition of the pulse if the timing condition is true. When triggering on a negative pulse, the trigger event occurs on the low to high transition of the pulse if the timing condition is true.

Suffix:

<m> 1..3
Event in a trigger sequence: 1 = A-event only

Parameters:

<Polarity> POSitive | NEGative | EITHer
*RST: POSitive

TRIGger<m>:PARAllel:WIDTh:RANGe <RangeMode>

Selects how the range of a pulse width is defined:

Suffix:

<m> 1..3
Event in a trigger sequence: 1 = A-event only

Parameters:

<RangeMode> WITHin | OUTSide | SHORter | LONGer

WITHin | OUTSide

Pulses inside or outside a given time range. The time range *Width ± Delta* is defined by TRIGger<m>:PARAllel:WIDTh:WIDTh and TRIGger<m>:PARAllel:WIDTh:DELTA.

SHORter | LONGer

Pulses shorter or longer than a given width defined by TRIGger<m>:PARAllel:WIDTh:WIDTh

*RST: WITHin

TRIGger<m>:PARAllel:WIDTh:WIDTh <Width>

Sets the limit for the pulse width.

The effect depends on TRIGger<m>:PARAllel:WIDTh:RANGe.

- For the ranges SHORter and LONGer, the width defines the maximum and minimum pulse width, respectively.
- For the ranges WITHin and OUTSide, the width defines the center of a range which is defined by the limits TRIGger<m>:PARAllel:WIDTh:DELTA.

Suffix:

<m> 1..3
Event in a trigger sequence: 1 = A-event only

Parameters:

<Width> Range: 200E-12 to 10000
Increment: 200E-9
*RST: 5E-9
Default unit: s

TRIGger<m>:PARAllel:WIDTh:DELTA <WidthDelta>

Defines a range around the given width value. the setting is relevant if [TRIGger<m>:PARAllel:WIDTh:RANGe](#) is set to WITHin or OUTSide. The width is set with [TRIGger<m>:PARAllel:WIDTh:WIDTh](#).

Suffix:

<m> 1..3
Event in a trigger sequence: 1 = A-event only

Parameters:

<WidthDelta> Range: 0 to 432
Increment: 600E-12
*RST: 0
Default unit: s

Timeout Trigger

See also:

- [TRIGger<m>:PARAllel:TIMEout:EXPRession\[:DEFine\]](#) on page 1060
- | | |
|---|------|
| TRIGger<m>:PARAllel:TIMEout:RANGe | 1062 |
| TRIGger<m>:PARAllel:TIMEout:TIME | 1063 |

TRIGger<m>:PARAllel:TIMEout:RANGe <TimeoutMode>

Sets the state condition.

Suffix:

<m> 1..3
Event in a trigger sequence: 1 = A-event only

Parameters:

<TimeoutMode> HIGH | LOW | EITHER

HIGH

The level of a digital channel stays above the threshold, or the logical expression for LOGic trigger source is true.

LOW

The level of a digital channel stays below the threshold, or the logical expression for LOGic trigger source is false.

EITHER

The signal state remains unchanged.

*RST: HIGH

TRIGger<m>:PARAllel:TIMEout:TIME <Time>

Defines the time limit for the timeout at which the instrument triggers.

Suffix:

<m> 1..3
Event in a trigger sequence: 1 = A-event only

Parameters:

<Time> Range: 100E-12 to 10000
Increment: 100E-9
*RST: 100E-9
Default unit: s

Data2Clock Trigger

See also:

- [TRIGger<m>:PARAllel:DATatoclock:CSource\[:VALue\]](#) on page 1059

TRIGger<m>:PARAllel:DATatoclock:CSource:EDGE	1063
TRIGger<m>:PARAllel:DATatoclock:STIME	1064
TRIGger<m>:PARAllel:DATatoclock:HTIME	1064

TRIGger<m>:PARAllel:DATatoclock:CSource:EDGE <ClockEdge>

Sets the edge of the clock signal. The crossing of the clock edge and the logical threshold defines the time reference point for the setup and hold time measurement.

Suffix:

<m> 1..3
Event in a trigger sequence: 1 = A-event only

Parameters:

<ClockEdge> POSitive | NEGative | EITHER
*RST: POSitive

TRIGger<m>:PARAllel:DATatoclock:STIME <SetupTime>

Sets the minimum time *before* the clock edge while data should be stable and not change its state.

See also: "[Setup time](#)" on page 530

Suffix:

<m> 1..3
Event in a trigger sequence: 1 = A-event only

Parameters:

<SetupTime> Range: -99.8E-9 to 100E-9
Increment: 1E-9
*RST: 0
Default unit: s

TRIGger<m>:PARAllel:DATatoclock:HTIME <HoldTime>

Sets the minimum time *after* the clock edge while data should be stable and not change its state.

See also: "[Hold time](#)" on page 530

Suffix:

<m> 1..3
Event in a trigger sequence: 1 = A-event only

Parameters:

<HoldTime> Range: -99.8E-9 to 100E-9
Increment: 1E-9
*RST: 0
Default unit: s

State Trigger

See also:

- [TRIGger<m>:PARAllel:STATe:CSourCe:VALue](#) on page 1059
- [TRIGger<m>:PARAllel:STATe:EXPRession\[:DEFine\]](#) on page 1060

[TRIGger<m>:PARAllel:STATe:CSourCe:EDGE](#).....1064
[TRIGger<m>:PARAllel:STATe:BIT<n>](#).....1065

TRIGger<m>:PARAllel:STATe:CSourCe:EDGE <Slope>

Sets the edge of the clock signal. The crossing of the clock edge and the logical threshold defines the time at which the logical states and the bus value are analyzed.

Suffix:

<m> 1..3
Event in a trigger sequence: 1 = A-event only

Parameters:

<Slope> POSitive | NEGative | EITHER
 *RST: POSitive

TRIGger<m>:PARAllel:STATe:BIT<n> <Bit>

Sets the required state for each digital channel that is used in the bus.

Suffix:

<m> 1..3
 Event in a trigger sequence: 1 = A-event only

<n> 0..15
 Number of the digital channel

Parameters:

<Bit> HIGH | LOW | DONTCARE
 Bit value: 1, 0, or X

Pattern Trigger**TRIGger<m>:PARAllel:PATtern:BIT<n> <Bit>**

Sets the required state for each digital channel that is used in the bus.

Suffix:

<m> 1..3
 Event in a trigger sequence: 1 = A-event only

<n> 0..15
 Number of the digital channel

Parameters:

<Bit> HIGH | LOW | DONTCARE
 Bit value: 1, 0, or X

TRIGger<m>:PARAllel:PATtern:MODE <Mode>

Sets the mode of the timing condition.

Suffix:

<m> 1..3
 Event in a trigger sequence: 1 = A-event only

Parameters:

<Mode>

OFF | TIMEout | WIDTH

OFF

No timing condition, only the logical pattern condition is relevant.

TIMEout

Defines a minimum time qualification to avoid triggering on unstable or transitional conditions. Use `TRIGger<m>:PARAllel:PATtern:TIMEout:MODE` and `TRIGger<m>:PARAllel:PATtern:TIMEout[:TIME]` to specify the timeout.

WIDTH

Sets a pulse width as timing condition. The pulse starts when the pattern comes true, and the trigger event occurs when the pattern comes false during the specified time limit. Use `TRIGger<m>:PARAllel:PATtern:WIDTH:RANGE`, `TRIGger<m>:PARAllel:PATtern:WIDTH[:WIDTH]`, and `TRIGger<m>:PARAllel:PATtern:WIDTH:DELTA` to specify the width.

*RST: OFF

TRIGger<m>:PARAllel:PATtern:TIMEout:MODE <TimeoutMode>

Sets the state condition for the timeout qualification if `TRIGger<m>:PARAllel:PATtern:MODE` is set to TIMEout. To set the time limit, use `TRIGger<m>:PARAllel:PATtern:TIMEout[:TIME]`.

Suffix:

<m>

1..3

Event in a trigger sequence: 1 = A-event only

Parameters:

<TimeoutMode>

HIGH | LOW | EITHER

HIGH: The pattern stays true for the specified time.

LOW: The pattern stays false for the specified time.

EITHER: The pattern remains unchanged for the specified time.

*RST: HIGH

TRIGger<m>:PARAllel:PATtern:TIMEout[:TIME] <Time>

Defines the time limit for the timeout at which the instrument triggers.

Suffix:

<m>

1..3

Event in a trigger sequence: 1 = A-event only

Parameters:

<Time>

Range: 100E-12 to 10000

Increment: 100E-9

*RST: 100E-9

Default unit: s

TRIGger<m>:PARAllel:PATtern:WIDTh:RANGe <WidthRangeMode>

Selects how the range of a pulse width is defined if `TRIGger<m>:PARAllel:PATtern:MODE` is set to `WIDTh`.

Suffix:

<m> 1..3
Event in a trigger sequence: 1 = A-event only

Parameters:

<WidthRangeMode> WITHin | OUTSide | SHORter | LONGer

WITHin

Triggers when the pattern comes false inside a given time range. The time limit is defined by `TRIGger<m>:PARAllel:PATtern:WIDTh[:WIDTh]` and `TRIGger<m>:PARAllel:PATtern:WIDTh:DELta` (*Width ± Delta*).

OUTSide

Triggers when the pattern comes false before or after the given time range. The time limit definition is the same as for `WITHin` range.

SHORter | LONGer

Triggers when the pattern comes false before or after the given width has expired. Width is set with `TRIGger<m>:PARAllel:PATtern:WIDTh[:WIDTh]`.

*RST: WITHin

TRIGger<m>:PARAllel:PATtern:WIDTh[:WIDTh] <Width>

The effect depend on the setting of the `TRIGger<m>:PARAllel:PATtern:WIDTh:RANGe` command.

For the ranges `SHORter` and `LONGer`, the width defines the maximum and minimum time limit, respectively.

For the ranges `WITHin` and `OUTSide`, the width defines the center of a range which is defined by the limits "±Delta".

Suffix:

<m> 1..3
Event in a trigger sequence: 1 = A-event only

Parameters:

<Width> Range: 100E-12 to 10000
Increment: 100E-9
*RST: 5E-9
Default unit: s

TRIGger<m>:PARAllel:PATtern:WIDTh:DELTA <WidthDelta>

Defines a range around the width value set with [TRIGger<m>:PARAllel:PATtern:WIDTh\[:WIDTh\]](#).

Suffix:

<m> 1..3
Event in a trigger sequence: 1 = A-event only

Parameters:

<WidthDelta> Range: 0 to 432
Increment: 500E-12
*RST: 0
Default unit: s

Serial Pattern Trigger

See also:

- [TRIGger<m>:PARAllel:SPATtern:CSource\[:VALue\]](#) on page 1059
- [TRIGger<m>:PARAllel:SPATtern:EXPRession\[:DEFine\]](#) on page 1060

TRIGger<m>:PARAllel:SPATtern:CSource:EDGE <ClockEdge>

Sets the edge of the clock signal. The bit value is determined at the crossing of the clock edge and the logical threshold.

Suffix:

<m> 1..3
Event in a trigger sequence: 1 = A-event only

Parameters:

<ClockEdge> POSitive | NEGative | EITHER
*RST: POSitive

TRIGger<m>:PARAllel:SPATtern:PATtern <Pattern>

Defines the serial bit string on which to trigger.

Suffix:

<m> 1..3
Event in a trigger sequence: 1 = A-event only

Parameters:

<Pattern> Numeric or string pattern, see [chapter 21.2.3.6, "Bit Pattern Parameter"](#), on page 667. The bit value X (don't care) is not allowed.

21.2.18.4 MSO Decoding Results

[DIGital<m>:DATA:HEADer?](#)..... 1069
[DIGital<m>:DATA\[:VALues\]?](#)..... 1069

DIGital<m>:DATA:HEADer?**Suffix:**

<m> 0..15

Usage: Query only
SCPI confirmed**DIGital<m>:DATA[:VALues]?**

Returns the data of the indicated digital channel. for transmission from the instrument to the controlling computer. The data can be used in MATLAB, for example.

To set the export format, use `FORMat [:DATA]`.

Suffix:<m> 0..15
Selects the digital channel.**Return values:**

<Data> List of values according to the format settings.

Usage: Query only**21.2.19 I/Q Software Interface (Option R&S RTO-K11)**

- [I/Q Sampling Settings](#)..... 1069
- [I/Q Data Output](#)..... 1072
- [NFC Trigger](#)..... 1074

21.2.19.1 I/Q Sampling Settings

To switch on input channels, use `CHANnel<m>:STATe`.

IQ:STATe	1069
CHANnel<m>:IQ:INPTyPe	1070
CHANnel<m>:IQ:INPMoDe	1070
IQ:RBWidth	1070
IQ:BWIDth?	1071
IQ:SRATe	1071
IQ:RLENGth	1071
CHANnel<m>:IQ:CFRequency	1071
CHANnel<m>:IQ:SBRF	1072
CHANnel<m>:IQ:SBIF	1072

IQ:STATe <IQMode>

Activates the I/Q mode of the instrument.

Parameters:

<IQMode> ON | OFF
 ON: I/Q mode
 OFF: normal oscilloscope mode
 *RST: OFF

CHANnel<m>:IQ:INPType <IQInputType>

Sets the type of the input signal.

Suffix:

<m> 1..4

Parameters:

<IQInputType> REAL | COMPLex

REAL

Real RF signal. One real RF signal requires one input channel, thus up to four real signals can be recorded in parallel.

COMPLex

Complex I/Q signal in baseband or low IF range. One complex input signal requires two input channels. The In-Phase component must be connected to channel 1 or 3, and the Quadrature component must be connected to channel 2 or 4. Thus up to two complex input signals can be recorded in parallel.

*RST: REAL

CHANnel<m>:IQ:INPMode <IQInputMode>

Selects the frequency band of a complex input signal.

Suffix:

<m> 1..4
 Selects the input channel.

Parameters:

<IQInputMode> BASeband | RFIF
 Baseband or intermediate frequency (RFIF)
 *RST: BASeband

IQ:RBWidth <RelBandwidth>

sets the bandwidth factor to define the filter bandwidth.

*Filter BW = Relative BW * Sample rate*

Parameters:

<RelBandwidth> Range: 0.04 to 0.8
 Increment: 0.01
 *RST: 0.8

IQ:BWIDth?

Returns the filter bandwidth.

See also: [IQ:BWIDth?](#) on page 1071

Return values:

<AbsBandwidth>	Range:	0 to 10E+9
	Increment:	1
	*RST:	4E+9
	Default unit:	Hz

Usage: Query only

IQ:SRATe <SampleRate>

Sets the required sample rate of the output I/Q data.

Parameters:

<SampleRate>	Range:	1000 to 10E+9
	Increment:	1
	*RST:	10E+9
	Default unit:	Sa/s

IQ:RLENgth <RecLength>

Sets the required record length of the output I/Q data. The resulting acquisition time of the I/Q data is:

$$\text{Acquisition time} = \text{Record length} / \text{Sample rate}$$

Parameters:

<RecLength>	Range:	1000 to 10000000
	Increment:	1
	*RST:	100000
	Default unit:	Sa

CHANnel<m>:IQ:CFRequency <IQCarrierFreq>

Sets the carrier frequency of the modulated RF signal or of the complex signal in IF range.

Prerequisites:

- [CHANnel<m>:IQ:INPType](#) on page 1070 is set to `REAL` or:
- [CHANnel<m>:IQ:INPType](#) on page 1070 is set to `COMPLex` and [CHANnel<m>:IQ:INPMode](#) on page 1070 is set to `RFIF`

Suffix:

<m>	1..4
-----	------

Selects the input channel.

Parameters:

<IQCarrierFreq> Range: 100 to 5E+9
 Increment: 100
 *RST: 1E+6
 Default unit: Hz

CHANnel<m>:IQ:SBRF <IQSidebandRF>

Defines the frequency position of the RF spectrum in the input signal: normal or inverse. The position is important for correct down-conversion and filtering.

Prerequisite: [CHANnel<m>:IQ:INPType](#) on page 1070 is set to `REAL`

For details, see "[Sideband \(real input\)](#)" on page 540

Suffix:

<m> 1..4
 Selects the input channel.

Parameters:

<IQSidebandRF> INVerse | NORMAl
 *RST: NORMAl

CHANnel<m>:IQ:SBIF <IQSidebandIF>

Defines the sideband and the frequency position of complex modulated input signal in IF range.

Prerequisites: [CHANnel<m>:IQ:INPType](#) on page 1070 is set to `COMPLex` and
[CHANnel<m>:IQ:INPMode](#) on page 1070 is set to `RFIF`

For details, see "[Sideband \(complex IF input\)](#)" on page 540

Suffix:

<m> 1..4
 Selects the input channel.

Parameters:

<IQSidebandIF> NUPPer | NLOWer | IUPPer | ILOWer
 NUPPer: Upper sideband in normal position
 NLOWer: Lower sideband in normal position
 IUPPer: Upper sideband in inverse position
 ILOWer: Lower sideband in inverse position
 *RST: NUPPer

21.2.19.2 I/Q Data Output

[CHANnel<m>:IQ:DATA\[:VALues\]?](#).....1073
[CHANnel<m>:IQ:DATA:HEADer?](#).....1073

CHANnel<m>:IQ:DATA[:VALues]?

Returns the recorded I/Q data.

Suffix:

<m> 1..4
Selects the input channel.
In case of a complex input signal that requires two input channels, the results of sources Ch1 and Ch2 are identical, as well as the results of Ch3 and Ch4.

Return values:

<Data> In-phase and and Quadrature floating values in interleaved order.

Example:

```
CHAN1:IQ:DATA?
-9.6296054835E-005, -1.5046258568E-006,
0.0001013283545, 1.5832555391E-006,
-0.00014297277085, -2.233616442E-006,
0.000192677413, 3.0105845781E-006,
-0.00020517286612, -3.2058260331E-006,
-0.002648930531, -4.1546467401E-005,
-0.0028401580639, -4.4135249482E-005,
-0.0028636774514, -4.4877564505E-005, ...
```

Usage: Query only

CHANnel<m>:IQ:DATA:HEADer?

Returns the header of I/Q data.

Table 21-20: Header data

Position	Meaning	Example
1	XStart, acquisition time before trigger, in s	-5E-008 = - 50 ns
2	XStop, acquisition time after trigger, in s	5E-008 = 50 ns
3	Record length of the waveform in Samples	1000
4	Number of values per sample interval. For I/Q data the result is 1.	1

Suffix:

<m> 1..4
Selects the input channel.

Example:

```
CHAN1:IQ:DATA:HEAD?
-5E-008, 5E-008, 1000, 1
```

Usage: Query only
SCPI confirmed

21.2.19.3 NFC Trigger

TRIGger<m>:NFC:TECHnology.....	1074
TRIGger<m>:NFC:BITRate.....	1074
TRIGger<m>:NFC:EVENT.....	1074

TRIGger<m>:NFC:TECHnology <Technology>

Selects the NFC technology, the communication protocol used by the input signal.

Suffix:

<m> 1..3
Event in a trigger sequence: 1 = A-event only

Parameters:

<Technology> NFCA | NFCB | NFCF
*RST: NFCA

TRIGger<m>:NFC:BITRate <Bitrate>

Sets the bit rate of the signal. For NFC-A and NFC-B, the bit rate is always 106 kBit per second. For NFC-F, the bit rate can be either 212 or 424 kBit per second.

Suffix:

<m> 1..3
Event in a trigger sequence: 1 = A-event only

Parameters:

<Bitrate> KBPS106 | KBPS212 | KBPS424
*RST: KBPS106

TRIGger<m>:NFC:EVENT <Event>

Sets the event to be triggered on.

Suffix:

<m> 1..3
Event in a trigger sequence: 1 = A-event only

Parameters:

<Event>

ALL | SEN | ALLB | SENB | SOS48 | SOS96

ALL | SEN

ALL_REQ and SENS_REQ commands (polling requests), only with NFC-A technology

ALLB | SENB

ALLB_REQ and SENSB_REQ commands, only with NFC-B technology

SOS48 | SOS96

Start of sequence, 48 bit 96 bit land length, only with NFC-F technology

*RST: SEN

21.2.20 Jitter Measurements and Clock Data Recovery (Options R&S RTO-K12/13)

This chapter describes the remote commands of jitter option R&S RTO-K12 and CDR option R&S RTO-K13. The options are available for R&S RTO firmware version 1.50 and higher.

- [Jitter Measurements \(Option R&S RTO-K12\)](#)..... 1075
- [Clock Data Recovery \(Software-based, Option R&S RTO-K12\)](#).....1080
- [Clock Data Recovery \(Hardware-based, Option R&S RTO-K13\)](#)..... 1083
- [CDR Trigger](#)..... 1085
- [Eye Mask Testing \(Option R&S RTO-K12\)](#)..... 1086

21.2.20.1 Jitter Measurements (Option R&S RTO-K12)

The following table lists the measurement suffixes and the <MeasType> parameter value with a short description.

For a detailed description, see [chapter 17.1.2, "Jitter Measurement Types"](#), on page 546.

Table 21-21: Jitter measurement types

Meas. suffix	<MeasType> parameter value	Meas. type	Description/Result
37	CCJitter	Cycle-cycle jitter	Difference between the periods of two adjacent cycles. The measurement is based on the period measurement.
38	NCJitter	N-cycle jitter	Difference between the period of cycles that are N cycles apart. The measurement is based on the period measurement.
39	CCWidth	Cycle-cycle width	Difference between the pulse width of two adjacent cycles. The measurement is based on the pulse width measurement.
40	CCDutycycle	Cycle-cycle duty cycle	Difference between the duty cycle of two adjacent cycles. The measurement is based on the duty cycle measurement.

Meas. suffix	<MeasType> parameter value	Meas. type	Description/Result
41	TIE	Time interval error	Time difference between the slope of the input signal and the slope of a reference signal. The reference signal can be a captured clock waveform, or a clock generated by clock data recovery (CDR, software algorithm or hardware generation).
42	UINterval	Unit interval	Period of the clock signal. If no clock signal is available, it is recovered by CDR. The period is calculated as the time difference between two consecutive clock edges of the same polarity.
43	DRATe	Data rate	Frequency of the clock signal. If no clock signal is available, it is recovered by CDR. The measurement is based on the unit interval measurement.
44	SKWDelay	Skew delay	Delay between the edges of two interdependent waveforms.
45	SKWPhase	Skew phase	Phase difference between the edges of two waveforms.
1 to 36; 46	Used for amplitude/time measurements (limit checks). The jitter category uses the same limit checks as amplitude/time. See chapter 21.2.11.3, "Amplitude/Time Measurement" , on page 810.		

MEASurement<m>:JITTer:CCSLope	1076
MEASurement<m>:JITTer:PULSe	1077
MEASurement<m>:JITTer:COFFset	1077
MEASurement<m>:JITTer:CDRMode	1078
MEASurement<m>:JITTer:SOURce<n>:TIESlope	1078
MEASurement<m>:JITTer:SKWSlope	1079
MEASurement<m>:JITTer:SKWRelation	1079

MEASurement<m>:JITTer:CCSLope <CCSLope>

Selects the slope at which the periods and thus the jitter is measured.

The command is available for the following measurements: cycle-cycle jitter, N-cycle jitter, and cycle-cycle duty cycle ([MEASurement<m>:MAIN](#) and/or [MEASurement<m>:ADDITIONal](#) are set to measurement types CCJitter | NCJitter | CCDutycycle).

Suffix:

<m>

1..9

See "[Measurement selection: MEASurement<m>](#)" on page 789.

Parameters:

<CCSlope>

FIRSt | POSitive | NEGative | EITHer

FIRSt

Measures the period from the first edge that is found, no matter of its direction.

POSitive

Measures the period at positive going edges.

NEGative

Measures the period at negative going edges.

EITHer

Measures the period at both positive and negative going edges. This option is useful, for example, to check the clock stability of a double data rate clock.

*RST: FIRSt

MEASurement<m>:JITTer:PULSe <PulsePolarity>

Sets the polarity of pulses for which the pulse width is measured to obtain the cycle-cycle width and the cycle-cycle duty cycle.

The command is available for the following measurements: cycle-cycle width and cycle-cycle duty cycle ([MEASurement<m>:MAIN](#) and/or [MEASurement<m>:ADDITIONal](#) are set to measurement types CCWidth | CCDutycycle).

Suffix:

<m>

1..9

See "[Measurement selection: MEASurement<m>](#)" on page 789.**Parameters:**

<PulsePolarity>

POSitive | NEGative

Pulse width of positive or negative pulses is measured, respectively.

*RST: POSitive

MEASurement<m>:JITTer:COFFset <CycleOffset>

Sets the distance between the cycles whose periods are taken for the jitter measurement. For example, if "Cycle offset" = $N = 3$, the periods of the first cycle and of the fourth ($N + 1 = 4$) cycle are measured, and their difference is the N-cycle jitter.

The command is available for the N-cycle jitter measurement ([MEASurement<m>:MAIN](#) and/or [MEASurement<m>:ADDITIONal](#) are set to measurement type NCJitter).

Suffix:

<m>

1..9

See "[Measurement selection: MEASurement<m>](#)" on page 789.

Parameters:

<CycleOffset> Range: 1 to 2147483647
 Increment: 1
 *RST: 2

MEASurement<m>:JITTer:CDRMode <CDRMode>

Defines the origin of the clock signal - whether a real clock signal or a clock generated using one of the CDR methods.

The command is available for the following measurements: time-interval error, unit interval and data rate ([MEASurement<m>:MAIN](#) and/or [MEASurement<m>:ADDITIONal](#) are set to measurement types TIE | UINTErval | DRATE).

Suffix:

<m> 1..9
 See "[Measurement selection: MEASurement<m>](#)" on page 789.

Parameters:

<CDRMode> SIGNAL | SW1 | SW2

SIGNAL

The clock is a real clock signal.

SW1 | SW2

The clock is generated by a software algorithm. You can define two software algorithms for CDR. To configure the CDR, use the `CDR:SOFTWARE` commands.

*RST: SW1

MEASurement<m>:JITTer:SOURce<n>:TIESlope <TIESlope>

Sets the clock and data edges that are used for measurements. Clock or data is defined by the `SOURCE` suffix <n>.

The command is available for the following measurements: time-interval error, unit interval and data rate ([MEASurement<m>:MAIN](#) and/or [MEASurement<m>:ADDITIONal](#) are set to measurement types TIE | UINTErval | DRATE).

Suffix:

<m> 1..9
 See "[Measurement selection: MEASurement<m>](#)" on page 789.

<n> 1..2
 1 = data slope (only relevant for time interval error measurements with explicit clock signal)
 2 = clock slope

Parameters:

<TIESlope> POSitive | NEGative | EITHer

POSitive

The positive clock slope can be used, for example, for single data rate (SDR) signals with bit start at the positive clock edge.

NEGative

The negative clock slope can be used, for example, for SDR signals with bit start at the negative clock edge.

EITHer

For clock edges, this option can be used for double data rate (DDR) signals.

For data edges, it is the most common setting.

*RST: EITHer

MEASurement<m>:JITTer:SKWSlope <SkewSlope>

Sets the edge of the first waveform from which the skew delay or phase is measured: positive, negative or both.

The command is available for the following measurement types: skew delay and skew phase ([MEASurement<m>:MAIN](#) and/or [MEASurement<m>:ADDITIONal](#) are set to measurement types SKWDelay | SKWPhase).

Suffix:

<m> 1..9

See "[Measurement selection: MEASurement<m>](#)" on page 789.

Parameters:

<SkewSlope> POSitive | NEGative | EITHer

*RST: POSitive

MEASurement<m>:JITTer:SKWRelation <SkewRelation>

Sets the edge of the second waveform relative to the first waveform.

The command is available for the following measurement types: skew delay and skew phase ([MEASurement<m>:MAIN](#) and/or [MEASurement<m>:ADDITIONal](#) are set to measurement types SKWDelay | SKWPhase).

Suffix:

<m> 1..9

See "[Measurement selection: MEASurement<m>](#)" on page 789.

Parameters:

<SkewRelation> MATChing | INVerse

MATChing

Measures from positive to positive edge or from negative to negative edge.

INVerse

Measures from positive to negative edge or from negative to positive edge.

*RST: MATChing

21.2.20.2 Clock Data Recovery (Software-based, Option R&S RTO-K12)

CDR:SOFTware<m>:ALGorithm.....	1080
CDR:SOFTware<m>:BITRate.....	1080
CDR:SOFTware<m>:ESLope.....	1081
CDR:SOFTware<m>:SYNC.....	1081
CDR:SOFTware<m>:RESults.....	1081
CDR:SOFTware<m>:PLL:ORDER.....	1082
CDR:SOFTware<m>:PLL:BWIDth.....	1082
CDR:SOFTware<m>:PLL:RELBwidth.....	1082
CDR:SOFTware<m>:PLL:DAMPing.....	1083

CDR:SOFTware<m>:ALGorithm <Algorithm>

Sets the software algorithm that is used for clock data recovery.

Suffix:

<m> 1..2
 Number of the software CDR setup

Parameters:

<Algorithm> PLL
 PLL is the phase-locked loop control system. It can follow slow deviations in the frequency of the data stream.
 *RST: PLL

CDR:SOFTware<m>:BITRate <Bitrate>

Sets the quiescent frequency of the PLL. It corresponds to the data rate of the data stream from which the clock is to be recovered.

Suffix:

<m> 1..2
 Number of the software CDR setup

Parameters:

<Bitrate> Range: 200E+3 to 5E+9
 Increment: 10
 *RST: 1E+9
 Default unit: bps

CDR:SOFTware<m>:ESLope <Edge>

Selects the edges of the data stream that are used for the clock recovery.

- "Either": Both positive and negative edges are used
- "Positive / Negative": Only one edge direction is used. Use one of these settings if the other edge might deliver unreliable results.

Suffix:

<m> 1..2
Number of the software CDR setup

Parameters:

<Edge> POSitive | NEGative | EITHer
*RST: EITHer

CDR:SOFTware<m>:SYNC <InitialSync>

Defines the phase reference for the first clock edge.

Suffix:

<m> 1..2
Number of the software CDR setup

Parameters:

<InitialSync> SAMPlE | DATaedge

SAMPlE

The first clock edge matches the first sample of the waveform at the left border of the display.

DATaedge

The first clock edge matches the first edge of the data signal.

*RST: SAMPlE

CDR:SOFTware<m>:RESults <Results>

The PLL requires some time to synchronize to the phase of the data stream. You can select when the CDR algorithm returns clock edges.

Suffix:

<m> 1..2
Number of the software CDR setup

Parameters:

<Results>

ALL | AISYnc

ALL

All clock edges are used.

AISYnc

The clock edges of the synchronization time are discarded; results are gathered after initial synchronization of the CDR. Thus, meaningful TIE measurement results can be obtained.

*RST: AISYnc

CDR:SOFTware<m>:PLL:ORDER <PLLOrder>

Sets the order of the PLL: first or second order. PLL of higher order can compensate for more complex jitter behavior.

Suffix:

<m>

1..2

Number of the software CDR setup

Parameters:

<PLLOrder>

FIRSt | SEConD

*RST: FIRSt

CDR:SOFTware<m>:PLL:BWIDth <PLLBandwidth>

Sets the PLL bandwidth. It defines the part of the spectrum that the PLL can follow during synchronization. The PLL bandwidth is usually defined by the transmission standard.

Suffix:

<m>

1..2

Number of the software CDR setup

Parameters:

<PLLBandwidth>

Range: Nominal BITRate * Range of RELBwidth (dependent range)

Increment: 10

*RST: 599.88E+3

Default unit: Hz

CDR:SOFTware<m>:PLL:RELBwidth <PLLRelBandwidth>

Sets the relative bandwidth, that is the ratio of the nominal bit rate to the PLL bandwidth.

Suffix:

<m>

1..2

Number of the software CDR setup

Parameters:

<PLLRelBandwidth> Range: 10 to 5000
 Increment: 1
 *RST: 1667

CDR:SOFTware<m>:PLL:DAMPing <DampingFactor>

Sets the damping factor, which is only relevant for second order PLL.

Suffix:

<m> 1..2
 Number of the software CDR setup

Parameters:

<DampingFactor> Range: 0.5 to 1
 Increment: 0.01
 *RST: 0.7

21.2.20.3 Clock Data Recovery (Hardware-based, Option R&S RTO-K13)

CDR:HARDware:SOURce.....	1083
CDR:HARDware:BITRate.....	1083
CDR:HARDware:ESLope.....	1084
CDR:HARDware:PLL:ORDer.....	1084
CDR:HARDware:PLL:BWIDth.....	1084
CDR:HARDware:PLL:RELBwidth.....	1084
CDR:HARDware:PLL:DAMPing.....	1085
TRIGger<m>:LEVel<n>[:VALue].....	1085

CDR:HARDware:SOURce <Source>

Selects the channel signal that is used for clock recovery.

The source cannot be changed if the CDR trigger is selected in the trigger setup. In this case, the instrument triggers on the recovered clock; trigger source and CDR source are the same.

Parameters:

<Source> CHANnel1 | CHANnel2 | CHANnel3 | CHANnel4
 *RST: CHANnel1

CDR:HARDware:BITRate <Bitrate>

Sets the quiescent frequency of the PLL. It corresponds to the data rate of the data stream from which the clock is to be recovered.

CDR:HARDware:PLL:DAMPing <DampingFactor>

Sets the damping factor, which is only relevant for second order PLL.

Parameters:

<DampingFactor> Range: 0.5 to 1
 Increment: 0.01
 *RST: 0.7

TRIGger<m>:LEVel<n>[:VALue] <Level>

Sets the trigger level for the specified event and source.

If the trigger source is serial bus, the trigger level is set by the thresholds in the protocol configuration.

The clock data recovery module (CDR option R&S RTO-K13) uses the trigger level also as threshold to detect signal edges. In this case, m = 1 and n = 1 | 2 | 3 | 4.

Suffix:

<m> 1..3
 Indicates the event in a trigger sequence: 1 = A-event, 2 = B-event, 3 = R-event.

<n> 1..9
 Indicates the trigger source:
 1...4 = channel 1 to 4, available for all events m = 1 ..3
 5 = External Trigger Input on the rear panel for analog signals, available for A-event, m = 1
 6...9 = not available

Parameters:

<Level> Voltage for the trigger level.
 Range: -10 to 10
 Increment: 1E-3
 *RST: 0
 Default unit: V

Example:

TRIG:LEV5 0.01

Sets the trigger level for the external trigger signal to 10 mV.

TRIG2:LEV3 0.2

Sets the trigger level for the B-event and B-trigger source channel 3 to 200 mV.

21.2.20.4 CDR Trigger

CDR:HARDware:UIOffset..... 1086
 TRIGger<m>:LEVel<n>[:VALue]..... 1086

CDR:HARDware:UIOffset <UnitIntervalOffs>

Defines an offset for the bit start, the beginning of the unit interval. The trigger point corresponds to the clock edge that indicates the bit start. The UI offset is a number between 0 and 1. Value 0 matches sets the clock edge to the beginning of the bit period; value 0.5 sets the clock edge to the middle of the bit period.

Parameters:

<UnitIntervalOffs> Range: 0 to 1
 Increment: 0.01
 *RST: 0

TRIGger<m>:LEVel<n>[:VALue] <Level>

Sets the trigger level for the specified event and source.

If the trigger source is serial bus, the trigger level is set by the thresholds in the protocol configuration.

The clock data recovery module (CDR option R&S RTO-K13) uses the trigger level also as threshold to detect signal edges. In this case, m = 1 and n = 1 | 2 | 3 | 4.

Suffix:

<m> 1..3
 Indicates the event in a trigger sequence: 1 = A-event, 2 = B-event, 3 = R-event.

<n> 1..9
 Indicates the trigger source:
 1...4 = channel 1 to 4, available for all events m = 1 ..3
 5 = External Trigger Input on the rear panel for analog signals, available for A-event, m = 1
 6...9 = not available

Parameters:

<Level> Voltage for the trigger level.
 Range: -10 to 10
 Increment: 1E-3
 *RST: 0
 Default unit: V

Example:

TRIG:LEV5 0.01
 Sets the trigger level for the external trigger signal to 10 mV.
 TRIG2:LEV3 0.2
 Sets the trigger level for the B-event and B-trigger source channel 3 to 200 mV.

21.2.20.5 Eye Mask Testing (Option R&S RTO-K12)

MTESt:EYEMask:TYPE.....	1087
MTESt:EYEMask:HEIGHt<m>[:VALue].....	1087
MTESt:EYEMask:WIDTh<m>[:VALue].....	1087

MTESt:EYEMask:MSKRight.....	1088
MTESt:EYEMask:MSKLeft.....	1088
MTESt:EYEMask:HPERiod.....	1088
MTESt:EYEMask:MSKTop.....	1088
MTESt:EYEMask:MSKBottom.....	1088
MTESt:EYEMask:TOFFset.....	1089
MTESt:EYEMask:BOFFset.....	1089
MTESt:EYEMask:TBSYmmetric.....	1089
MTESt:EYEMask:TBWidth.....	1089
MTESt:EYEMask:HPOSition.....	1089
MTESt:EYEMask:VPOSition.....	1090

MTESt:EYEMask:TYPE <MaskTestName>,<Type>

MTESt:EYEMask:TYPE? <MaskTestName>

Defines the outline of the eye mask.

Parameters:

<Type> SQUare | DIAMond | HEXagon | OCTagon
 *RST: DIAMond

Parameters for setting and query:

<MaskTestName> String with the name of the mask test

MTESt:EYEMask:HEIGHt<m>[:VALue] <MaskTestName>, <value>

Defines the main height of all eye mask shapes and the minor height for octagon mask shapes.

Suffix:

<m> 1..2
 1 - main width
 2 - minor width

Parameters:

<value> Default unit: s

Setting parameters:

<MaskTestName> String with the name of the mask test

MTESt:EYEMask:WIDTh<m>[:VALue] <MaskTestName>, <value>

Defines the main width of all eye mask shapes and the minor width for hexagon and octagon mask shapes.

Suffix:

<m> 1..2
 1 - main width
 2 - minor width

Parameters:

<value> Default unit: s

Setting parameters:

<MaskTestName> String with the name of the mask test

MTESt:EYEMask:MSKRight <MaskTestName>,<Copy>

MTESt:EYEMask:MSKRight? <MaskTestName>

MTESt:EYEMask:MSKLeft <MaskTestName>,<Copy>

MTESt:EYEMask:MSKLeft? <MaskTestName>

Copies the eye shape to the right and left, respectively.

The distance of the copy is defined using [MTESt:EYEMask:HPERiod](#).

Parameters:

<Copy> ON | OFF

*RST: OFF

Parameters for setting and query:

<MaskTestName> String with the name of the mask test

MTESt:EYEMask:HPERiod <MaskTestName>,<InterpatternLength>

MTESt:EYEMask:HPERiod? <MaskTestName>

defines the time distance between the shape centers if [MTESt:EYEMask:MSKLeft](#) and/or [MTESt:EYEMask:MSKRight](#) are ON.

Parameters:

<InterpatternLength> Range: 0 to 100

Increment: 0.01

*RST: 0.5

Default unit: s

Parameters for setting and query:

<MaskTestName> String with the name of the mask test

MTESt:EYEMask:MSKTop <MaskTestName>,<Add>

MTESt:EYEMask:MSKTop? <MaskTestName>

MTESt:EYEMask:MSKBottom <MaskTestName>,<Add>

MTESt:EYEMask:MSKBottom? <MaskTestName>

Enable the upper (top) and lower (bottom) mask region, respectively.

Parameters:

<Add> ON | OFF

*RST: OFF

Parameters for setting and query:

<MaskTestName> String with the name of the mask test

MTESt:EYEMask:TOFFset <MaskTestName>,<Offset>
MTESt:EYEMask:TOFFset? <MaskTestName>
MTESt:EYEMask:BOFFset <MaskTestName>,<Offset>
MTESt:EYEMask:BOFFset? <MaskTestName>

Voltage distance from the eye shape center that limit the upper (TOFFset) and lower (BOFFset) regions.

Parameters:

<Offset> Range: 0 to 100
 Increment: 0.01
 *RST: 0.5
 Default unit: V

Parameters for setting and query:

<MaskTestName> String with the name of the mask test

MTESt:EYEMask:TBSYmmetric <MaskTestName>,<Symmetry>
MTESt:EYEMask:TBSYmmetric? <MaskTestName>

Sets bottom and top offsets to the same value so that the outer regions are symmetric to the eye shape.

Parameters:

<Symmetry> ON | OFF
 *RST: ON

Parameters for setting and query:

<MaskTestName> String with the name of the mask test

MTESt:EYEMask:TBWidth <MaskTestName>,<RectangleLength>
MTESt:EYEMask:TBWidth? <MaskTestName>

Sets the time width of the outer regions, symmetric to the eye shape center.

Parameters:

<RectangleLength> Range: 0 to 100
 Increment: 0.01
 *RST: 0.5
 Default unit: s

Parameters for setting and query:

<MaskTestName> String with the name of the mask test

MTESt:EYEMask:HPOsition <MaskTestName>,<PatOffsetX>
MTESt:EYEMask:HPOsition? <MaskTestName>

Sets the horizontal (time) value of the eye shape enter and thus defines the horizontal position of the eye shape on the display.

Parameters:

<PatOffsetX> Range: -100 to 100
 Increment: 0.01
 *RST: 0
 Default unit: s

Parameters for setting and query:

<MaskTestName> String with the name of the mask test

MTES: EYEMask: VPosition <MaskTestName>, <PatOffsetY>

MTES: EYEMask: VPosition? <MaskTestName>

Sets the vertical (voltage) value of the eye shape enter and thus defines the vertical position of the eye shape on the display.

Parameters:

<PatOffsetY> Range: -100 to 100
 Increment: 0.01
 *RST: 0
 Default unit: V

Parameters for setting and query:

<MaskTestName> String with the name of the mask test

21.2.21 Power Analysis (Option R&S RTO-K31)

• General	1090
• Deskew	1091
• Report	1092
• Power Quality	1097
• Inrush Current	1099
• Current Harmonic	1101
• Modulation Analysis	1103
• Dynamic ON Resistance	1104
• Slew Rate	1106
• S.O.A	1108
• Turn On/Off	1110
• Switching Loss	1112
• Power Efficiency	1115
• Ripple	1116
• Transient Response	1118
• Spectrum	1121

21.2.21.1 General

POWER:ENABLE	1091
POWER:SOURce:CURRent<1..2>	1091
POWER:SOURce:VOLTage<1..4>	1091

POWer:ENABle

Activates the power mode and initializes the power measurements. If the power mode is disabled, the instrument does not accept any POWer command.

Use POWer:ENABle after each *RST.

Example: See [chapter 21.3.6.1, "Auto Deskew"](#), on page 1135

Usage: Event

POWer:SOURce:CURRent<1..2> <CurrentSource>

Sets the channel for the current source.

Parameters:

<CurrentSource> CHANnel1 | CHANnel2 | CHANnel3 | CHANnel4

Usage: Asynchronous command

POWer:SOURce:VOLTage<1..4> <VoltageSource>

Sets the channel for the voltage source input.

Parameters:

<VoltageSource> CHANnel1 | CHANnel2 | CHANnel3 | CHANnel4

Usage: Asynchronous command

21.2.21.2 Deskew

Programming example: [chapter 21.3.6.1, "Auto Deskew"](#), on page 1135

POWer:DESKew:CURRent.....	1091
POWer:DESKew:EXECute.....	1091
POWer:DESKew:RESet.....	1092
POWer:DESKew:TIME?.....	1092
POWer:DESKew:UDPReset.....	1092

POWer:DESKew:CURRent

Applies the result of the auto deskew to the "Skew offset" value.

Usage: Event

POWer:DESKew:EXECute

Starts the auto deskew.

Usage: Event
Asynchronous command

POWER:DESKew:RESet <OverwriteCurrSkew>

Overwrites the present skew setup.

Parameters:

<OverwriteCurrSkew> ON | OFF

*RST: ON

POWER:DESKew:TIME?

Queries the result of the auto deskew.

Return values:

<AutoDeskewOffs> Range: -100E-9 to 100E-9

*RST: 0

Default unit: s

Usage: Query only

POWER:DESKew:UDPReset <UserDefinedPreset>

Activates or deactivates a user defined setup. If ON, the instrument setup including probe setup and the deskew values are written to a user defined preset file (saveset) that can be loaded using [MMEMoRY:RCL](#) on page 919.

The default path is:

Windows XP:

C:\Documents and Settings\All
Users\Documents\Rohde-Schwarz\RTO\SaveSets.

Windows 7:

C:\Users\Public\Documents\Rohde-Schwarz\RTO\SaveSets\

Parameters:

<UserDefinedPreset> ON | OFF

*RST: ON

21.2.21.3 Report

POWER:REPort:CONTent:HSETup	1093
POWER:REPort:CONTent:MSETup	1093
POWER:REPort:CONTent:MSIGNAL	1093
POWER:REPort:CONTent:RESU	1093
POWER:REPort:CONTent:SETTings	1093
POWER:REPort:CONTent:TITLe	1093
POWER:REPort:CONTent:TSETup	1093
POWER:REPort:CONTent:VSETup	1093
POWER:REPort:DESCRiption	1093
POWER:REPort:DUT	1093

POWer:REPort:SITe.....	1093
POWer:REPort:TEMPerature.....	1093
POWer:REPort:USER.....	1093
POWer:REPort:FONT:COLO.....	1094
POWer:REPort:FONT:FAMI.....	1094
POWer:REPort:FONT:SIZE.....	1094
POWer:REPort:LOGO.....	1094
POWer:REPort:PAPersize.....	1094
POWer:REPort:FILE:DELeTe.....	1094
POWer:REPort:FILE:NAME.....	1094
POWer:REPort:FILE:NEW.....	1094
POWer:REPort:FILE:SAVE.....	1094
POWer:REPort:TEST:ADD.....	1094
POWer:REPort:TEST:INSert.....	1094
POWer:REPort:TEST:REMOve.....	1094
POWer:REPort:INVert.....	1095
POWer:REPort:TEST:DSEA.....	1095
POWer:REPort:TEST:ISE.....	1095
POWer:REPort:TEST:SEA.....	1095
POWer:REPort:TEST:RSE.....	1095
POWer:REPort:TEST:DIRectory.....	1096
POWer:REPort:TEST:COMMeNt.....	1096
POWer:REPort:TEST:COUNt.....	1097
POWer:REPort:TEST:LSENd?.....	1097

POWer:REPort:CONTent:HSETup <ContentHorizSetup>
POWer:REPort:CONTent:MSETup <ContentMeasSetup>
POWer:REPort:CONTent:MSIGNal <ContentMeasuredSigns>
POWer:REPort:CONTent:RESU <ContentResults>
POWer:REPort:CONTent:SETTings <ContentSettings>
POWer:REPort:CONTent:TITLe <ContentTitle>
POWer:REPort:CONTent:TSETup <ContentTrigSetup>
POWer:REPort:CONTent:VSETup <ContentVertSetup>

Sets how often the respective content is shown in the final report.

Parameters:

<ContentVertSetup> ALWAYS | NEVER | ONCE

*RST: ONCE

POWer:REPort:DESCRiption <Description>
POWer:REPort:DUT <DUT>
POWer:REPort:SITe <Site>
POWer:REPort:TEMPerature <Temperature>
POWer:REPort:USER <User>

Sets a value that can be shown at the titel page of a report.

Parameters:

<User>

POWer:REPort:FONT:COLO <FontColor>
POWer:REPort:FONT:FAMI <FontFamily>
POWer:REPort:FONT:SIZE <FontSize>
POWer:REPort:LOGO <LogoFile>
POWer:REPort:PAPersize <PaperSize>

Set the layout of your report.

Parameters:

<PaperSize> A4 | USL
 *RST: A4

POWer:REPort:FILE:DELeTe
POWer:REPort:FILE:NAME <Path>
POWer:REPort:FILE:NEW
POWer:REPort:FILE:SAVE

Manage files.

Usage: Event

POWer:REPort:TEST:ADD <MeasType>
POWer:REPort:TEST:INSert <MeasType>, <Index>
POWer:REPort:TEST:REMOve <MeasType>, <Index>

Manage reports.

Setting parameters:

<MeasType> QUAL | RUSH | HARM | MODU | DONR | SLEW | SOA | TURN |
SWIT | EFF | RIPP | TRANS | SPEC

QUAL

Power Quality

RUSH

Inrush Current

HARM

Current Harmonic

MODU

Modulation Analysis

DONR

Dynamic ON Resistance

SLEW

Slew Rate

SOA

Safe Operating Area (S.O.A.)

TURN

Turn On/Off

SWIT

Switching Loss

EFF

Power Efficiency

RIPP

Ripple

TRANS

Transient Response

SPEC

Spectrum

<Index>

Usage: Setting only

POWER:REPort:INVert <InvertScreenshotColor>

POWER:REPort:TEST:DSEA <MeasType>

POWER:REPort:TEST:ISE <MeasType>

POWER:REPort:TEST:SEA <MeasType>

POWER:REPort:TEST:RSE <MeasType>

Manage the selection of reports.

Parameters:

<MeasType>	QUAL RUSH HARM MODU DONR SLEW SOA TURN SWIT EFF RIPP TRANS SPEC
	QUAL Power Quality
	RUSH Inrush Current
	HARM Current Harmonic
	MODU Modulation Analysis
	DONR Dynamic ON Resistance
	SLEW Slew Rate
	SOA Safe Operating Area (S.O.A.)
	TURN Turn On/Off
	SWIT Switching Loss
	EFF Power Efficiency
	RIPP Ripple
	TRANS Transient Response
	SPEC Spectrum

POWER:REPort:TEST:DIRectory <MeasType>, <DirectoryPath>

POWER:REPort:TEST:DIRectory? <MeasType>

Selects the directory, in which the reports are saved.

Setting parameters:

<DirectoryPath>

Parameters for setting and query:

<MeasType>	QUAL RUSH HARM MODU DONR SLEW SOA TURN SWIT EFF RIPP TRANS SPEC
------------	---

POWER:REPort:TEST:COMMent <MeasType>, <Comment>

POWER:REPort:TEST:COMMent? <MeasType>

Sets a comment for the report.

Setting parameters:

<Comment>

Parameters for setting and query:

<MeasType> QUAL | RUSH | HARM | MODU | DONR | SLEW | SOA | TURN |
SWIT | EFF | RIPP | TRANS | SPEC

POWER:REPort:TEST:COUNT <MeasType>**Parameters:**

<MeasType> QUAL | RUSH | HARM | MODU | DONR | SLEW | SOA | TURN |
SWIT | EFF | RIPP | TRANS | SPEC

Return values:

<Count>

POWER:REPort:TEST:LSEnd? <MeasType>**Query parameters:**

<MeasType> QUAL | RUSH | HARM | MODU | DONR | SLEW | SOA | TURN |
SWIT | EFF | RIPP | TRANS | SPEC

Usage: Query only

21.2.21.4 Power Quality

POWER:QUALity:AUTO.....	1097
POWER:QUALity:EXECute.....	1098
POWER:QUALity:FREQ.....	1098
POWER:QUALity:REPort:ADD.....	1098
POWER:QUALity:RESult:CURRent:CREStfactor?.....	1098
POWER:QUALity:RESult:CURRent:FREQuency?.....	1098
POWER:QUALity:RESult:CURRent:PEAK?.....	1098
POWER:QUALity:RESult:CURRent:RMS?.....	1098
POWER:QUALity:RESult:POWER:APParent?.....	1098
POWER:QUALity:RESult:POWER:PFACTOR?.....	1098
POWER:QUALity:RESult:POWER:PHASe?.....	1098
POWER:QUALity:RESult:POWER:REACTive?.....	1098
POWER:QUALity:RESult:POWER:REALpower?.....	1098
POWER:QUALity:RESult:VOLTage:CREStfactor?.....	1098
POWER:QUALity:RESult:VOLTage:FREQuency?.....	1098
POWER:QUALity:RESult:VOLTage:PEAK?.....	1098
POWER:QUALity:RESult:VOLTage:RMS?.....	1098

POWER:QUALity:AUTO <Autoscale>

Selects the scaling for the display of the results.

Parameters:

<Autoscale> AUTO | MANUAL
 *RST: MANUAL

POWER:QUALity:EXECute

Starts the power quality measurement.

Usage: Event

POWER:QUALity:FREQ <Frequency>

Sets the input frequency of the source signal in Hz.

Parameters:

<Frequency> F_50 | F_60 | F_360 | F_400 | F_650 | F_800 | NF_F_650 |
 WF_F_800 | F_CUS
 *RST: F_50

POWER:QUALity:REPort:ADD

Adds the result to the report list.

Usage: Event

POWER:QUALity:RESult:CURRent:CREStfactor?
POWER:QUALity:RESult:CURRent:FREQuency?
POWER:QUALity:RESult:CURRent:PEAK?
POWER:QUALity:RESult:CURRent:RMS?
POWER:QUALity:RESult:POWer:APParent?
POWER:QUALity:RESult:POWer:PFACtor?
POWER:QUALity:RESult:POWer:PHASe?
POWER:QUALity:RESult:POWer:REACTive?
POWER:QUALity:RESult:POWer:REALpower?
POWER:QUALity:RESult:VOLTag:e:CREStfactor?
POWER:QUALity:RESult:VOLTag:e:FREQuency?
POWER:QUALity:RESult:VOLTag:e:PEAK?
POWER:QUALity:RESult:VOLTag:e:RMS?

Returns the value of the respective result.

Return values:

<RMS> Range: -1000 to 1000
 *RST: 1
 Default unit: V

Usage: Query only

21.2.21.5 Inrush Current

POWER:INRush:ADD.....	1099
POWER:INRush:INSert.....	1099
POWER:INRush:REMOve.....	1099
POWER:INRush:COUnT?.....	1099
POWER:INRush:EXECute.....	1099
POWER:INRush:GATE<m>:STARt.....	1100
POWER:INRush:GATE<m>:STOP.....	1100
POWER:INRush:GATE<m>:VALue.....	1100
POWER:INRush:MAXCurrent.....	1100
POWER:INRush:TRIGger.....	1100
POWER:INRush:REPOrt:ADD.....	1101

POWER:INRush:ADD

Adds a gate.

Usage: Event

POWER:INRush:INSert <GateIndex>

Inserts a gate.

Setting parameters:

<GateIndex>

Usage: Setting only

POWER:INRush:REMOve <GateIndex>

Removes a gate

Setting parameters:

<GateIndex>

Usage: Setting only

POWER:INRush:COUnT?

Queiries the number of inrush current gates.

Return values:

<Count>

Usage: Query only

POWER:INRush:EXECute

Starts the inrush current measurement.

Usage: Event
Asynchronous command

POWER:INRush:GATE<m>:START <StartTime>

POWER:INRush:GATE<m>:STOP <StopTime>

Sets the measuring time for the selected gate.

Suffix:

<m> *

Parameters:

<StopTime> Range: 0 to 10
Increment: 0
*RST: 100E-6
Default unit: s

POWER:INRush:GATE<m>:VALue <Value>

Returns the value of the inrush current.

Suffix:

<m> *

Parameters:

<Value> Range: -1000 to 1000
Increment: 0
*RST: 0
Default unit: A

POWER:INRush:MAXCurrent <MaxExpCurr>

Sets the maximum expected current for the vertical scale.

Parameters:

<MaxExpCurr> Range: -1000 to 1000
Increment: 0
*RST: 10
Default unit: A

POWER:INRush:TRIGger <TrigCurrValue>

Sets the current value for the trigger.

Parameters:

<TrigCurrValue> Range: -1000 to 1000
Increment: 0
*RST: 1
Default unit: A

POWER:INRush:REPort:ADD

Adds the result to the report list.

Usage: Event

21.2.21.6 Current Harmonic

POWER:HARMonics:AUTO.....	1101
POWER:HARMonics:DOFR.....	1101
POWER:HARMonics:ENFR.....	1101
POWER:HARMonics:MIFR.....	1101
POWER:HARMonics:EVAL.....	1101
POWER:HARMonics:EXECute.....	1102
POWER:HARMonics:REPort:ADD.....	1102
POWER:HARMonics:RESult<m>:FREQuency<n>:VALue?.....	1102
POWER:HARMonics:RESult<m>:MAXValue<n>:VALue?.....	1102
POWER:HARMonics:RESult<m>:STDinuse?.....	1102
POWER:HARMonics:RESult<m>:STDValue<n>:VALue?.....	1102
POWER:HARMonics:RESult<m>:VALue<n>:VALue?.....	1102
POWER:HARMonics:STAN.....	1102
POWER:HARMonics:VOLT.....	1102

POWER:HARMonics:AUTO <Autoscale>

Selects the scaling for the display of the results.

Parameters:

<Autoscale> AUTO | MANUAL
*RST: MANUAL

POWER:HARMonics:DOFR <160>

POWER:HARMonics:ENFR <61000>

POWER:HARMonics:MIFR <1399>

Selects the frequency of the input signal.

Parameters:

<1399> F_400 | F_60
*RST: F_400

POWER:HARMonics:EVAL <Current>

Sets the evaluation of the results for "Standard" > "RTCA DO-160".

Parameters:

<Current> REVISED | NOREVISED
*RST: NOREVISED

POWER:HARMonics:EXECute

Starts the current harmonic measurement.

Usage: Event

POWER:HARMonics:REPort:ADD

Adds the result to the report list.

Usage: Event

POWER:HARMonics:RESult<m>:FREQUency<n>:VALue?**POWER:HARMonics:RESult<m>:MAXValue<n>:VALue?****POWER:HARMonics:RESult<m>:STDinuse?****POWER:HARMonics:RESult<m>:STDValue<n>:VALue?****POWER:HARMonics:RESult<m>:VALue<n>:VALue?**

Returns the value of the respective result.

Suffix:

<m> 1..2

<n> *

Return values:

<Value> Range: -1000 to 1000
*RST: 0
Default unit: A

Usage: Query only

POWER:HARMonics:STAN <Use>

Sets a standard for the current harmonic measurement.

Parameters:

<Use> ENA | ENB | ENC | END | MIL | RTC
*RST: ENA

POWER:HARMonics:VOLT <Result>

Selects if the voltage results are displayed or not for "Standard" > "RTCA DO-160" and enabled "Evaluation with voltage source and revised current law".

Parameters:

<Result> VOLTDISP | NOVOLTDISP
*RST: NOVOLTDISP

Example: POW:HARM:STAN RTC
 POW:HARM:EVAL REVISED
 POW:HARM:VOLT NOVOLTDISP
 selects an evaluation with the revised current law and no voltage display

21.2.21.7 Modulation Analysis

POWer:MODulation:AUTO.....	1103
POWer:MODulation:DHISistogram.....	1103
POWer:MODulation:EXECute.....	1103
POWer:MODulation:REPort:ADD.....	1103
POWer:MODulation:RESult:ACTual?.....	1104
POWer:MODulation:RESult:AVG?.....	1104
POWer:MODulation:RESult:EVTCount?.....	1104
POWer:MODulation:RESult:NPEak?.....	1104
POWer:MODulation:RESult:PPEak?.....	1104
POWer:MODulation:RESult:RMS?.....	1104
POWer:MODulation:RESult:STDDev?.....	1104
POWer:MODulation:RESult:WFMCOUNT?.....	1104
POWer:MODulation:SOURce.....	1104
POWer:MODulation:TYPE.....	1104

POWer:MODulation:AUTO <Autoscale>

Selects the scaling for the display of the results.

Parameters:

<Autoscale> AUTO | MANUAL
 *RST: MANUAL

POWer:MODulation:DHISistogram <DispHistg>

Activates or deactivates the display of a histogram.

Parameters:

<DispHistg> ON | OFF
 *RST: ON

POWer:MODulation:EXECute

Starts the modulation analysis measurement.

Usage:

Event
 Asynchronous command

POWer:MODulation:REPort:ADD

Adds the result to the report list.

Usage: Event

POWer:MODulation:RESult:ACTual? <MeasType>
POWer:MODulation:RESult:AVG? <MeasType>
POWer:MODulation:RESult:EVTCount? <MeasType>
POWer:MODulation:RESult:NPEak? <MeasType>
POWer:MODulation:RESult:PPEak? <MeasType>
POWer:MODulation:RESult:RMS? <MeasType>
POWer:MODulation:RESult:STDDev? <MeasType>
POWer:MODulation:RESult:WFMCCount? <MeasType>

Return the specified statistic result of the specified measurement type.

- [:ACTual]: current measurement result
- AVG: average of the long-term measurement results
- EVTCount: number of measurement results in the long-term measurement
- NPEak: negative peak value of the long-term measurement results
- PPEak: positive peak value of the long-term measurement results
- RMS: RMS value of the long-term measurement results
- STDDev: standard deviation of the long-term measurement results

Query parameters:

<MeasType> FREQ | DUTY

Usage: Query only

POWer:MODulation:SOURce <Source>

Selects the source for the measurement.

Parameters:

<Source> CURRENT | VOLTAGE
 *RST: VOLTAGE

POWer:MODulation:TYPE <AnalysisType>

Sets the type of measurement.

Parameters:

<AnalysisType> TURNON | CONT
 *RST: CONT

21.2.21.8 Dynamic ON Resistance

POWer:DONRes:AUTO	1105
POWer:DONRes:AVG	1105
POWer:DONRes:EXECute	1105
POWer:DONRes:GATE<m>:START	1105

POWER:DONRes:GATE<m>:STOP.....	1105
POWER:DONRes:REPort:ADD.....	1105
POWER:DONRes:RESult:RESistance?.....	1105

POWER:DONRes:AUTO <Autoscale>

Selects the scaling for the display of the results.

Parameters:

<Autoscale> AUTO | MANUAL
 *RST: MANUAL

POWER:DONRes:AVG <Average>

Enables/disables averaging.

Parameters:

<Average> ON | OFF
 *RST: ON

POWER:DONRes:EXECute

Starts the dynamic on resistance measurement.

Usage: Event
 Asynchronous command

POWER:DONRes:GATE<m>:START <Start>

POWER:DONRes:GATE<m>:STOP <Stop>

Sets the value for the cursor.

Suffix:

<m> 1..2

Parameters:

<Stop>

POWER:DONRes:REPort:ADD

Adds the result to the report list.

Usage: Event

POWER:DONRes:RESult:RESistance?

Returns the the dynamic on resistance value.

Return values:

<Resistance> Range: -100E+24 to 100E+24
 *RST: 0
 Default unit: \x2126

Usage: Query only

21.2.21.9 Slew Rate

POWER:SLEWrate:AUTO.....	1106
POWER:SLEWrate:AVGDeriv.....	1106
POWER:SLEWrate:EXECute.....	1106
POWER:SLEWrate:GATE:START.....	1107
POWER:SLEWrate:GATE:STOP.....	1107
POWER:SLEWrate:REPort:ADD.....	1107
POWER:SLEWrate:RESult:ACTual?.....	1107
POWER:SLEWrate:RESult:AVG?.....	1107
POWER:SLEWrate:RESult:EVTCount?.....	1107
POWER:SLEWrate:RESult:NPEak?.....	1107
POWER:SLEWrate:RESult:PPEak?.....	1107
POWER:SLEWrate:RESult:RMS?.....	1107
POWER:SLEWrate:RESult:STDDev?.....	1107
POWER:SLEWrate:RESult:WFMCOUNT?.....	1107
POWER:SLEWrate:SOURce.....	1107

POWER:SLEWrate:AUTO <Autoscale>

Selects the scaling for the display of the results.

Parameters:

<Autoscale> AUTO | MANUAL
 *RST: MANUAL

POWER:SLEWrate:AVGDeriv <AvgDerivative>

Activates or deactivates average.

Parameters:

<AvgDerivative> ON | OFF
 *RST: ON

POWER:SLEWrate:EXECute

Starts the slew rate measurement.

Usage: Event
 Asynchronous command

POWer:SLEWrate:GATE:START <T0>
POWer:SLEWrate:GATE:STOP <T1>

Sets the value for the cursor.

Parameters:

<T1>

POWer:SLEWrate:REPort:ADD

Adds the result to the report list.

Usage: Event

POWer:SLEWrate:RESult:ACTual? <MeasType>
POWer:SLEWrate:RESult:AVG? <MeasType>
POWer:SLEWrate:RESult:EVTCount? <MeasType>
POWer:SLEWrate:RESult:NPEak? <MeasType>
POWer:SLEWrate:RESult:PPEak? <MeasType>
POWer:SLEWrate:RESult:RMS? <MeasType>
POWer:SLEWrate:RESult:STDDev? <MeasType>
POWer:SLEWrate:RESult:WFMCCount? <MeasType>

Return the specified statistic result of the specified measurement type.

- [:ACTual]: current measurement result
- AVG: average of the long-term measurement results
- EVTCount: number of measurement results in the long-term measurement
- NPEak: negative peak value of the long-term measurement results
- PPEak: positive peak value of the long-term measurement results
- RMS: RMS value of the long-term measurement results
- STDDev: standard deviation of the long-term measurement results

Query parameters:

<MeasType> MIN | MAX

Usage: Query only

POWer:SLEWrate:SOURce <Source>

Selects the source for the slew rate measurement.

Parameters:

<Source> CURRENT | VOLTAGE
 *RST: VOLTAGE

21.2.21.10 S.O.A

POWer:SOA:EXECute.....	1108
POWer:SOA:LINear:ADD.....	1108
POWer:SOA:LOGarithmic:ADD.....	1108
POWer:SOA:LINear:COUNT?.....	1108
POWer:SOA:LOGarithmic:COUNT?.....	1108
POWer:SOA:LINear:REMOve.....	1108
POWer:SOA:LOGarithmic:REMOve.....	1108
POWer:SOA:LINear:INSert.....	1109
POWer:SOA:LOGarithmic:INSert.....	1109
POWer:SOA:LINear:POINt<m>:CURRent.....	1109
POWer:SOA:LOGarithmic:POINt<m>:CURRent.....	1109
POWer:SOA:LINear:POINt<m>:VOLTagE.....	1109
POWer:SOA:LOGarithmic:POINt<m>:VOLTagE.....	1109
POWer:SOA:MASK.....	1109
POWer:SOA:REPort:ADD.....	1109
POWer:SOA:SCALE.....	1110
POWer:SOA:SWITCh.....	1110

POWer:SOA:EXECute

Starts the safe operating area measurement.

Usage: Event

POWer:SOA:LINear:ADD**POWer:SOA:LOGarithmic:ADD**

Adds a point.

Usage: Event

POWer:SOA:LINear:COUNT?**POWer:SOA:LOGarithmic:COUNT?**

Queries the number of points.

Return values:

<Count>

Usage: Query only

POWer:SOA:LINear:REMOve <GateIndex>**POWer:SOA:LOGarithmic:REMOve <GateIndex>**

Removes a point.

Setting parameters:

<GateIndex>

Usage: Setting only

POWER:SOA:LINear:INSert <GateIndex>
POWER:SOA:LOGarithmic:INSert <GateIndex>

Inserts a point.

Setting parameters:
 <GateIndex>

Usage: Setting only

POWER:SOA:LINear:POINT<m>:CURRent <Amp>
POWER:SOA:LOGarithmic:POINT<m>:CURRent <Amp>

Sets the current value for the respective point.

Suffix:
 <m> *

Parameters:
 <Amp> Range: 0.01 to 1000
 Increment: 0
 *RST: 0.01
 Default unit: A

POWER:SOA:LINear:POINT<m>:VOLTage <Volt>
POWER:SOA:LOGarithmic:POINT<m>:VOLTage <Volt>

Sets the voltage value for the respective point.

Suffix:
 <m> *

Parameters:
 <Volt> Range: 1E-3 to 1000
 Increment: 0
 *RST: 1E-3
 Default unit: V

POWER:SOA:MASK <Test>

Activates or deactivates a mask.

Parameters:
 <Test> ON | OFF
 *RST: OFF

POWER:SOA:REPort:ADD

Adds the result to the report list.

Usage: Event

POWer:SOA:SCALe <Scale>

Sets the scale for the measurement.

Parameters:

<Scale> LOG | LINEAR
 *RST: LOG

POWer:SOA:SWITCh <Switch>

Switches between linear and logarithmic scale.

Parameters:

<Switch> LOGLINEAR | LINEARLOG
 *RST: LOGLINEAR

21.2.21.11 Turn On/Off

POWer:ONOFF:ATOff.....	1110
POWer:ONOFF:ATON.....	1110
POWer:ONOFF:DTOFF.....	1110
POWer:ONOFF:DTON.....	1110
POWer:ONOFF:DSOFF.....	1111
POWer:ONOFF:DSON.....	1111
POWer:ONOFF:EXECute.....	1111
POWer:ONOFF:INPut.....	1111
POWer:ONOFF:REPort:ADD.....	1111
POWer:ONOFF:RESult:TOff?.....	1111
POWer:ONOFF:RESult:TOn?.....	1111
POWer:ONOFF:STATe.....	1112
POWer:ONOFF:TIME.....	1112
POWer:ONOFF:TYPE.....	1112

POWer:ONOFF:ATOff <ACTrigLevOff>**POWer:ONOFF:ATON** <ACTrigLevOn>

Triggers the beginning of the measurements at the moment the AC input voltage reaches the set value.

Parameters:

<ACTrigLevOn> Range: -1E+6 to 1E+6
 Increment: 1E-3
 *RST: 10
 Default unit: V

POWer:ONOFF:DTOFF <ACTrigLevOff>**POWer:ONOFF:DTON** <ACTrigLevOn>

Triggers the beginning of the measurements at the moment the DC input voltage reaches the set value.

Parameters:

<ACTrigLevOn> Range: -1E+6 to 1E+6
 *RST: 10
 Default unit: V

POWER:ONOFF:DSOFF <DCSteadyStateLevOff>

POWER:ONOFF:DSON <DCSteadyStateLevOn>

Sets the percentage of the steady state level of the DC output that has to be reached.

Parameters:

<DCSteadyStateLevOn> Range: 0 to 100
 Increment: 1
 *RST: 90
 Default unit: %

POWER:ONOFF:EXECute

Starts the turn on/off measurement.

Usage: Event
 Asynchronous command

POWER:ONOFF:INPut <InputType>

Sets the input type.

Parameters:

<InputType> AC | DC
 *RST: AC

POWER:ONOFF:REPort:ADD

Adds the result to the report list.

Usage: Event

POWER:ONOFF:RESult:TOFF?

POWER:ONOFF:RESult:TON?

Returns the result time.

Return values:

<TurnOnTime> Range: -100E+24 to 100E+24
 Increment: 100E-12
 *RST: 0
 Default unit: s

Usage: Query only

POWER:ONOFF:STATE <State>

Sets the state of the turn on/ turn off measurement.

Parameters:

<State> ON | OFF
 *RST: OFF

POWER:ONOFF:TIME <Time>

Sets the time, the start of the measurement of the turn off time is delay with, after the trigger point.

Parameters:

<Time> Range: 100E-12 to 10000
 Increment: 100E-9
 *RST: 0.1
 Default unit: s

POWER:ONOFF:TYPE <MeasType>

Selects the turn on or the turn off measurement.

Parameters:

<MeasType> TON | TOFF
 *RST: TON

21.2.21.12 Switching Loss

POWER:SWITching:AUTO.....	1113
POWER:SWITching:EXECute.....	1113
POWER:SWITching:REPort:ADD.....	1113
POWER:SWITching:SWIFrequency.....	1113
POWER:SWITching:SWIT.....	1113
POWER:SWITching:COND.....	1114
POWER:SWITching:NCON.....	1114
POWER:SWITching:TON.....	1114
POWER:SWITching:TOFF.....	1114
POWER:SWITching:TOTal.....	1114
POWER:SWITching:GATE:COND:START.....	1114
POWER:SWITching:GATE:COND:STOP.....	1114
POWER:SWITching:GATE:NCON:START.....	1114
POWER:SWITching:GATE:NCON:STOP.....	1114
POWER:SWITching:GATE:TOFF:START.....	1114
POWER:SWITching:GATE:TOFF:STOP.....	1114
POWER:SWITching:GATE:TON:START.....	1114
POWER:SWITching:GATE:TON:STOP.....	1114
POWER:SWITching:RESult:ENERgy:ACTual?.....	1114
POWER:SWITching:RESult:ENERgy:AVG?.....	1114

POWer:SWITching:RESult:ENERgy:EVTCount?.....	1114
POWer:SWITching:RESult:ENERgy:NPEak?.....	1114
POWer:SWITching:RESult:ENERgy:PPEak?.....	1114
POWer:SWITching:RESult:ENERgy:RMS?.....	1114
POWer:SWITching:RESult:ENERgy:STDDev?.....	1114
POWer:SWITching:RESult:ENERgy:WFMCount?.....	1114
POWer:SWITching:RESult:POWer:ACTual?.....	1115
POWer:SWITching:RESult:POWer:AVG?.....	1115
POWer:SWITching:RESult:POWer:EVTCount?.....	1115
POWer:SWITching:RESult:POWer:NPEak?.....	1115
POWer:SWITching:RESult:POWer:PPEak?.....	1115
POWer:SWITching:RESult:POWer:RMS?.....	1115
POWer:SWITching:RESult:POWer:STDDev?.....	1115
POWer:SWITching:RESult:POWer:WFMCount?.....	1115

POWer:SWITching:AUTO <Autoscale>

Selects the scaling for the display of the results.

Parameters:

<Autoscale> AUTO | MANUAL
 *RST: MANUAL

POWer:SWITching:EXECute

Starts the switching loss measurement.

Usage: Event
 Asynchronous command

POWer:SWITching:REPort:ADD

Adds the result to the report list.

Usage: Event

POWer:SWITching:SWIFrequency <SwitchingFreq>

Sets the switching frequency.

Parameters:

<SwitchingFreq> Range: 1 to 500E+9
 Increment: 1000
 *RST: 10E+6
 Default unit: Hz

POWer:SWITching:SWIT <MeasureSwitchingFreq>

Activates or deactivates the measurements of the switching frequency.

Parameters:

<MeasureSwitchingFreq> ON | OFF
 *RST: ON

POWER:SWITching:COND <MeasureConduction>
POWER:SWITching:NCON <MeasureNonConduction>
POWER:SWITching:TON <MeasureTurnOn>
POWER:SWITching:TOFF <MeasureTurnOff>
POWER:SWITching:TOTal <MeasureTotal>

Enables the measurement during the respective period.

Parameters:

<MeasureTotal> ON | OFF
 *RST: ON

POWER:SWITching:GATE:COND:START <T1>
POWER:SWITching:GATE:COND:STOP <T2>
POWER:SWITching:GATE:NCON:START <T3>
POWER:SWITching:GATE:NCON:STOP <T4>
POWER:SWITching:GATE:TOFF:START <T2>
POWER:SWITching:GATE:TOFF:STOP <T3>
POWER:SWITching:GATE:TON:START <T0>
POWER:SWITching:GATE:TON:STOP <T1>

Sets the value for the respective cursor.

Parameters:

<T1>

POWER:SWITching:RESult:ENERgy:ACTual? <MeasType>
POWER:SWITching:RESult:ENERgy:AVG? <MeasType>
POWER:SWITching:RESult:ENERgy:EVTCount? <MeasType>
POWER:SWITching:RESult:ENERgy:NPEak? <MeasType>
POWER:SWITching:RESult:ENERgy:PPEak? <MeasType>
POWER:SWITching:RESult:ENERgy:RMS? <MeasType>
POWER:SWITching:RESult:ENERgy:STDDev? <MeasType>
POWER:SWITching:RESult:ENERgy:WFMCCount? <MeasType>

Return the specified statistic result of the specified measurement type.

- [:ACTual]: current measurement result
- AVG: average of the long-term measurement results
- EVTCount: number of measurement results in the long-term measurement
- NPEak: negative peak value of the long-term measurement results
- PPEak: positive peak value of the long-term measurement results
- RMS: RMS value of the long-term measurement results
- STDDev: standard deviation of the long-term measurement results

Query parameters:

<MeasType> SWF | TON | TOF | CON | NCO | TOT

Usage: Query only

POWER:SWITching:RESult:POWER:ACTual? <MeasType>
POWER:SWITching:RESult:POWER:AVG? <MeasType>
POWER:SWITching:RESult:POWER:EVTCount? <MeasType>
POWER:SWITching:RESult:POWER:NPEak? <MeasType>
POWER:SWITching:RESult:POWER:PPEak? <MeasType>
POWER:SWITching:RESult:POWER:RMS? <MeasType>
POWER:SWITching:RESult:POWER:STDDev? <MeasType>
POWER:SWITching:RESult:POWER:WFMCOUNT? <MeasType>

Return the specified statistic result of the specified measurement type.

- [:ACTual]: current measurement result
- AVG: average of the long-term measurement results
- EVTCount: number of measurement results in the long-term measurement
- NPEak: negative peak value of the long-term measurement results
- PPEak: positive peak value of the long-term measurement results
- RMS: RMS value of the long-term measurement results
- STDDev: standard deviation of the long-term measurement results

Query parameters:

<MeasType> SWF | TON | TOF | CON | NCO | TOT

Usage: Query only**21.2.21.13 Power Efficiency**

POWER:EFFiciency:AUTO.....	1115
POWER:EFFiciency:EXECute.....	1116
POWER:EFFiciency:REPort:ADD.....	1116
POWER:EFFiciency:RESult<m>:ACTual?.....	1116
POWER:EFFiciency:RESult<m>:AVG?.....	1116
POWER:EFFiciency:RESult<m>:EVTCount?.....	1116
POWER:EFFiciency:RESult<m>:NPEak?.....	1116
POWER:EFFiciency:RESult<m>:PPEak?.....	1116
POWER:EFFiciency:RESult<m>:RMS?.....	1116
POWER:EFFiciency:RESult<m>:STDDev?.....	1116
POWER:EFFiciency:RESult<m>:WFMCOUNT?.....	1116

POWER:EFFiciency:AUTO <Autoscale>

Selects the scaling for the display of the results.

Parameters:

<Autoscale> AUTO | MANUAL

*RST: MANUAL

POWer:EFFiciency:EXECute

Starts the power efficiency measurement.

Usage: Event

POWer:EFFiciency:REPort:ADD

Adds the result to the report list.

Usage: Event

POWer:EFFiciency:RESult<m>:ACTual?**POWer:EFFiciency:RESult<m>:AVG?****POWer:EFFiciency:RESult<m>:EVTCount?****POWer:EFFiciency:RESult<m>:NPEak?****POWer:EFFiciency:RESult<m>:PPEak?****POWer:EFFiciency:RESult<m>:RMS?****POWer:EFFiciency:RESult<m>:STDDev?****POWer:EFFiciency:RESult<m>:WFMCCount?**

Return the specified statistic result of the specified measurement type.

- [:ACTual]: current measurement result
- AVG: average of the long-term measurement results
- EVTCount: number of measurement results in the long-term measurement
- NPEak: negative peak value of the long-term measurement results
- PPEak: positive peak value of the long-term measurement results
- RMS: RMS value of the long-term measurement results
- STDDev: standard deviation of the long-term measurement results

Suffix:

<m> 1..3

Return values:

<WaveformsCount> Range: 0 to 4E+9
*RST: 0

Usage: Query only

21.2.21.14 Ripple

POWer:RIPPlE:AUToscale.....	1117
POWer:RIPPlE:CURRent.....	1117
POWer:RIPPlE:EXECute.....	1117
POWer:RIPPlE:FREQuency.....	1117
POWer:RIPPlE:REPort:ADD.....	1117
POWer:RIPPlE:RESult:FREQuency?.....	1117
POWer:RIPPlE:RESult:MAXimum?.....	1117
POWer:RIPPlE:RESult:MINimum?.....	1117

POWer:RIPPlE:RESult:NDCYcle?.....	1117
POWer:RIPPlE:RESult:PDCYcle?.....	1118
POWer:RIPPlE:RESult:PDEL?.....	1118
POWer:RIPPlE:RESult:PERiod?.....	1118
POWer:RIPPlE:RESult:STDDev?.....	1118

POWer:RIPPlE:AUToscale <Autoscale>

Selects the scaling for the display of the results.

Parameters:

<Autoscale> AUTO | MANUAL
 *RST: MANUAL

POWer:RIPPlE:CURRent <TwoChMeas>

Activates or deactivates the input current.

Parameters:

<TwoChMeas> ON | OFF
 *RST: ON

POWer:RIPPlE:EXECute

Starts the ripple measurement.

Usage: Event
 Asynchronous command

POWer:RIPPlE:FREQuency <SmPsFrequency>

Sets the SMPS switching frequency.

Parameters:

<SmPsFrequency> Range: 1 to 100E+6
 Increment: 1
 *RST: 1E+6
 Default unit: Hz

POWer:RIPPlE:REPort:ADD

Adds the result to the report list.

Usage: Event

POWer:RIPPlE:RESult:FREQuency? <VoltageMeasType>
POWer:RIPPlE:RESult:MAXimum? <VoltageMeasType>
POWer:RIPPlE:RESult:MINimum? <VoltageMeasType>
POWer:RIPPlE:RESult:NDCYcle? <VoltageMeasType>

POWer:RIPple:RESult:PDCYcle? <VoltageMeasType>

POWer:RIPple:RESult:PDEL? <VoltageMeasType>

POWer:RIPple:RESult:PERiod? <VoltageMeasType>

POWer:RIPple:RESult:STDDev? <VoltageMeasType>

Return the specified statistic result of the specified measurement type.

- MAXimum: maximum value of the waveform
- MINimum: minimum value of the waveform
- PDELta: peak-to-peak value of the waveform
- STDDev: standard deviation of the long-term measurement results
- PERiod: Length of the left-most signal period of the waveform
- FREQUENCY: Frequency of the signal. The result is based on the period measurement.
- PDCYcle: positive duty cycle. The measurement requires at least one complete period of a triggered signal.
- NDCYcle: negative duty cycle. The measurement requires at least one complete period of a triggered signal.

Query parameters:

<VoltageMeasType> VOLTage | CURRent

Usage: Query only

21.2.21.15 Transient Response

Programming example: [chapter 21.3.6.2, "Transient Response Measurement"](#), on page 1137

POWer:TRANSient:AUToscale	1118
POWer:TRANSient:EXECute	1119
POWer:TRANSient:FREQUency	1119
POWer:TRANSient:HYSteresis	1119
POWer:TRANSient:INPut	1119
POWer:TRANSient:REPort:ADD	1119
POWer:TRANSient:RESult[:ACTual]?	1119
POWer:TRANSient:SIGHigh	1120
POWer:TRANSient:SIGLow	1120
POWer:TRANSient:TRGChannel	1120
POWer:TRANSient:TRGLevel	1120
POWer:TRANSient:TRGSlope	1120

POWer:TRANSient:AUToscale <Autoscale>

Selects the scaling for the display of the results.

Parameters:

<Autoscale> AUTO | MANUAL

*RST: MANUAL

POWer:TRANsient:EXECute

Starts the transient response measurement.

Usage: Event
Asynchronous command

POWer:TRANsient:FREQuency <SmPsFrequency>

Sets the SMPS switching frequency.

Parameters:

<SmPsFrequency> Range: 1 to 100E+6
Increment: 1
*RST: 1E+6
Default unit: Hz

POWer:TRANsient:HYSTeresis <ExpOutputSignToITube>

Specifies a tolerated error band for the signal level.

Parameters:

<ExpOutputSignToITube> Range: 10 to 50
Increment: 1
*RST: 10
Default unit: %

POWer:TRANsient:INPut <ThreeChMeas>

Activates or deactivates the input voltage.

Parameters:

<ThreeChMeas> ON | OFF
*RST: OFF

POWer:TRANsient:REPort:ADD

Adds the result to the report list.

Usage: Event

POWer:TRANsient:RESult[:ACTual]? <MeasType>

Returns the results of the transient response measurement.

Query parameters:

<MeasType> OVERshoot | RTIME | DELay | PEAKtime | SETTling

Usage: Query only

POWer:TRANsient:SIGHigh <ExpHighOutputSignLev>

Sets the expected signal high voltage value.

Parameters:

<ExpHighOutputSignLev> Range: -10 to 10
 Increment: 1E-3
 *RST: 1
 Default unit: V

POWer:TRANsient:SIGLow <ExpLowOutputSignLev>

Sets the expected signal low voltage value.

Parameters:

<ExpLowOutputSignLev> Range: -10 to 10
 Increment: 1E-3
 *RST: 0
 Default unit: V

POWer:TRANsient:TRGChannel <TriggerSource>

Sets the source channel of the trigger.

Parameters:

<TriggerSource> CHAN1 | CHANNEL1 | CHAN2 | CHANNEL2 | CHAN3 |
 CHANNEL3 | CHAN4 | CHANNEL4 | EXTernanalog | LINE |
 SBUS | MSD | MSDS | MSBU
 *RST: CHAN1

POWer:TRANsient:TRGLevel <TriggerLevel>**Parameters:**

<TriggerLevel> Range: -10 to 10
 Increment: 1E-3
 *RST: 0
 Default unit: V

POWer:TRANsient:TRGSlope <TriggerSlope>

Sets the edge type for the trigger event.

Parameters:

<TriggerSlope> POSitive | NEGative | EITHer
 *RST: POSitive

21.2.21.16 Spectrum

POWer:SPECtrum:AUToscale.....	1121
POWer:SPECtrum:EXECute.....	1121
POWer:SPECtrum:FREQuency.....	1121
POWer:SPECtrum:REPort:ADD.....	1121
POWer:SPECtrum:RESult<m>:FREQuency?.....	1121
POWer:SPECtrum:RESult<m>:LEVel?.....	1122

POWer:SPECtrum:AUToscale <Autoscale>

Selects the scaling for the display of the results.

Parameters:

<Autoscale> AUTO | MANUAL
 *RST: MANUAL

POWer:SPECtrum:EXECute

Starts the spectrum measurement.

Usage: Event
 Asynchronous command

POWer:SPECtrum:FREQuency <SmpsFrequency>

Sets the SMPS switching frequency.

Parameters:

<SmpsFrequency> Range: 1 to 100E+6
 Increment: 1
 *RST: 1E+6
 Default unit: Hz

POWer:SPECtrum:REPort:ADD

Adds the result to the report list.

Usage: Event

POWer:SPECtrum:RESult<m>:FREQuency?

Returns the result frequency.

Suffix:

<m> 1..8

Return values:

<MeasResult>

Usage: Query only

POWER:SPECTrum:RESult<m>:LEVEL?

Returns the result level.

Suffix:

<m> 1..8

Return values:

<MeasResult>

Usage: Query only

21.2.22 Maintenance

DIAGnostic:SERVice:STST:EXECute	1122
DIAGnostic:SERVice:STST:STATe?	1122
DIAGnostic:SERVice:PWD	1122

DIAGnostic:SERVice:STST:EXECute

Starts the selftest.

Usage: Event
Asynchronous command

DIAGnostic:SERVice:STST:STATe?

Returns the summary result of the selftest.

Return values:

<State> PSSD | FAILED | UNDEFINED
*RST: UNDEFINED

Usage: Query only

DIAGnostic:SERVice:PWD <Password>

Sets the password to enter the service mode.

Setting parameters:

<Password> Password string

Usage: Setting only

21.2.23 Status Reporting

• STATus:OPERation Register	1123
• STATus:QUEStionable Registers	1123

21.2.23.1 STATus:OPERation Register

STATus:OPERation provide information on the activity of the instrument.

STATus:OPERation:CONDition?.....	1123
STATus:OPERation[:EVENT]?.....	1123

STATus:OPERation:CONDition? STATus:OPERation[:EVENT]?

The CONDition command returns information on actions the instrument is currently executing. The contents of the register is retained.

The EVENT command returns information on actions the instrument has executed since the last reading. Reading the EVENT register deletes its contents.

Bits:

- 0 = CALibrating
- 2 = AUToset
- 3= WTRigger (wait for trigger)
- 4= MEASuring

See also: "[STATus:OPERation Register](#)" on page 656.

Usage: Query only

21.2.23.2 STATus:QUEStionable Registers

The commands of the STATus:QUEStionable subsystem control the status reporting structures of the STATus:QUEStionable registers:

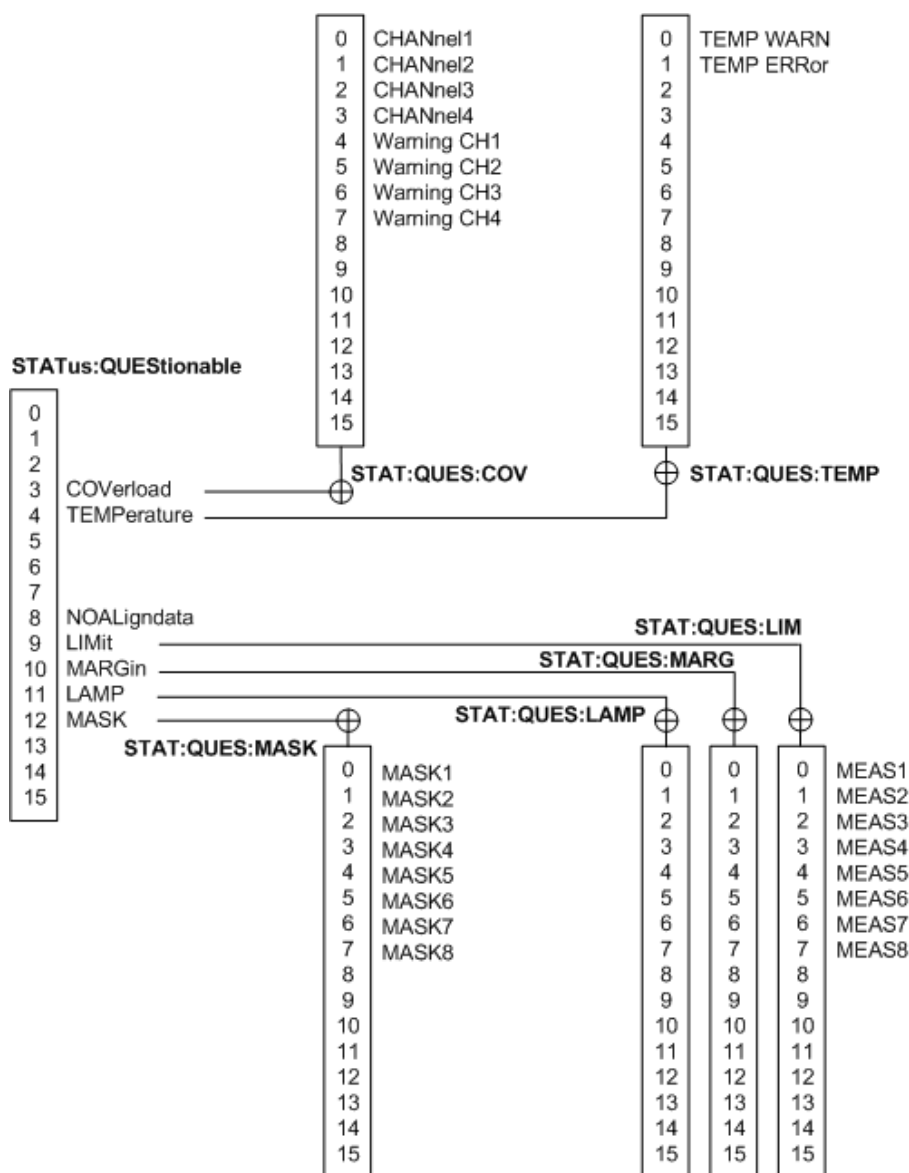

Fig. 21-4: Overview of the STATus:QUEStionable register

See also:

- [chapter 21.1.6.1, "Structure of a SCPI Status Register"](#), on page 651
- ["STATus:QUEStionable Register"](#) on page 657

The following commands are available:

STATus:QUEStionable:COVerload:CONDition?	1125
STATus:QUEStionable:TEMPerature:CONDition?	1125
STATus:QUEStionable:LIMit:CONDition?	1125
STATus:QUEStionable:MARGin:CONDition?	1125
STATus:QUEStionable:MASK:CONDition?	1125
STATus:QUEStionable:COVerload:ENABle	1125
STATus:QUEStionable:TEMPerature:ENABle	1125
STATus:QUEStionable:LIMit:ENABle	1125

STATus:QUESTionable:MARGin:ENABle.....	1125
STATus:QUESTionable:MASK:ENABle.....	1125
STATus:QUESTionable:COVerload[:EVENT]?	1126
STATus:QUESTionable:TEMPerature[:EVENT]?	1126
STATus:QUESTionable:LIMit[:EVENT]?	1126
STATus:QUESTionable:MARGin[:EVENT]?	1126
STATus:QUESTionable:MASK[:EVENT]?	1126
STATus:QUESTionable:COVerload:NTRansition.....	1126
STATus:QUESTionable:TEMPerature:NTRansition.....	1126
STATus:QUESTionable:LIMit:NTRansition.....	1126
STATus:QUESTionable:MARGin:NTRansition.....	1126
STATus:QUESTionable:MASK:NTRansition.....	1126
STATus:QUESTionable:COVerload:PTRansition.....	1126
STATus:QUESTionable:TEMPerature:PTRansition.....	1126
STATus:QUESTionable:LIMit:PTRansition.....	1126
STATus:QUESTionable:MARGin:PTRansition.....	1126
STATus:QUESTionable:MASK:PTRansition.....	1126

STATus:QUESTionable:COVerload:CONDition?
STATus:QUESTionable:TEMPerature:CONDition?
STATus:QUESTionable:LIMit:CONDition?
STATus:QUESTionable:MARGin:CONDition?
STATus:QUESTionable:MASK:CONDition?

Returns the contents of the CONDition part of the status register to check for questionable instrument or measurement states. Reading the CONDition registers does not delete the contents.

Usage: Query only
 SCPI confirmed

STATus:QUESTionable:COVerload:ENABle <Value>
STATus:QUESTionable:TEMPerature:ENABle <Value>
STATus:QUESTionable:LIMit:ENABle <Value>
STATus:QUESTionable:MARGin:ENABle <Value>
STATus:QUESTionable:MASK:ENABle <Value>

Sets the enable mask that allows true conditions in the EVENT part to be reported in the summary bit. If a bit is set to 1 in the enable part and its associated event bit transitions to true, a positive transition occurs in the summary bit and is reported to the next higher level.

Parameters:
 <Value> Bit mask in decimal representation

Example: STATus:QUESTionable:MASK:ENABle 24
 Set bits no. 3 and 4 of the STATus:QUESTionable:MASK:ENABle register part: $24 = 8 + 16 = 2^3 + 2^4$

Usage: SCPI confirmed

STATus:QUESTionable:COVerload[:EVENT]?
STATus:QUESTionable:TEMPerature[:EVENT]?
STATus:QUESTionable:LIMit[:EVENT]?
STATus:QUESTionable:MARGin[:EVENT]?
STATus:QUESTionable:MASK[:EVENT]?

Returns the contents of the EVENT part of the status register to check whether an event has occurred since the last reading. Reading an EVENT register deletes its contents.

Usage: Query only
SCPI confirmed

STATus:QUESTionable:COVerload:NTRansition <Value>
STATus:QUESTionable:TEMPerature:NTRansition <Value>
STATus:QUESTionable:LIMit:NTRansition <Value>
STATus:QUESTionable:MARGin:NTRansition <Value>
STATus:QUESTionable:MASK:NTRansition <Value>

Sets the negative transition filter. If a bit is set, a 1 to 0 transition in the corresponding bit of the condition register causes a 1 to be written in the corresponding bit of the event register.

Parameters:
<Value> Bit mask in decimal representation

Example: STATus:QUESTionable:MASK:NTRansition 24
Set bits no. 3 and 4 of the STATus:QUESTionable:MASK:NTRansition register part: $24 = 8 + 16 = 2^3 + 2^4$

Usage: SCPI confirmed

STATus:QUESTionable:COVerload:PTRansition <Value>
STATus:QUESTionable:TEMPerature:PTRansition <Value>
STATus:QUESTionable:LIMit:PTRansition <Value>
STATus:QUESTionable:MARGin:PTRansition <Value>
STATus:QUESTionable:MASK:PTRansition <Value>

Sets the positive transition filter. If a bit is set, a 0 to 1 transition in the corresponding bit of the condition register causes a 1 to be written in the corresponding bit of the event register.

Parameters:
<Value> Bit mask in decimal representation

Example: STATus:QUESTionable:MASK:PTRansition 24
Set bits no. 3 and 4 of the STATus:QUESTionable:MASK:PTRansition register part: $24 = 8 + 16 = 2^3 + 2^4$

Usage: SCPI confirmed

21.3 Programming Examples

21.3.1	Display.....	1127
21.3.1.1	Creating Zoom Diagrams.....	1127
21.3.2	Automatic Measurements.....	1128
21.3.2.1	Setting Reference Levels.....	1128
21.3.2.2	Waveform Histograms.....	1129
21.3.2.3	Long Term Measurements.....	1130
21.3.3	Mask Testing.....	1130
21.3.3.1	Creating a user mask.....	1130
21.3.4	Search.....	1131
21.3.4.1	Searching for a pulse of specified width.....	1131
21.3.5	Data Management.....	1131
21.3.5.1	Saving a Screenshot to File.....	1131
21.3.5.2	Exporting Waveform Data to File.....	1132
21.3.5.3	Exporting Measurement Results to File.....	1135
21.3.6	Power Analysis (Option R&S RTO-K31).....	1135
21.3.6.1	Auto Deskew.....	1135
21.3.6.2	Transient Response Measurement.....	1137

21.3.1 Display

21.3.1.1 Creating Zoom Diagrams

The example creates a zoom diagram, sets the relative size of the zoom area, and removes the zoom diagram.

Command description in: [chapter 21.2.8.5, "Zoom"](#), on page 761.

```
LAYout:ZOOM:ADD 'Diagram1', VERT, OFF, -10e-9, 20e-9, -0.1, 0.05, 'MyZoom1'
// Create an new zoom diagram for Diagram1
LAYout:ZOOM:HORIZ:MODE? 'Diagram1', 'MyZoom1'
<--ABS
// Query the horizontal zoom mode - return value: ABS
LAYout:ZOOM:HORIZ:MODE 'Diagram1', 'MyZoom1', REL
// Set horizontal zoom mode to relative
LAYout:ZOOM:HORIZ:REL:SPAN 'Diagram1', 'MyZoom1', 10
// Set horizontal zoom span in percent
LAYout:ZOOM:HORIZ:REL:POS 'Diagram1', 'MyZoom1', 15
// Set horizontal zoom position in percent
```

```
LAYout:ZOOM:REM 'Diagram1', 'MyZoom1'  
// Remove zoom diagram
```

21.3.2 Automatic Measurements

21.3.2.1 Setting Reference Levels

Command description in [chapter 21.2.11.2, "Reference Level"](#), on page 796.

Manual reference level definition using absolute values

The modes, the upper and lower reference level, and the top and bottom distance are set for waveform C1W1 (= suffix 2).

```
REFLevel2:LDEtection MANual  
REFLevel2:LMOde ABS  
REFLevel2:USRLevel UREF  
REFLevel2:ABSolute:LLEVel 0.001  
REFLevel2:ABSolute:BDistance 0.02  
REFLevel2:ABSolute:ULEVel 0.01  
REFLevel2:ABSolute:TDistance 0.03  
REFLevel2:ABSolute:MLEVel 0.005
```

Manual reference level definition using relative values

Reference levels are set to 15%, 50%, and 85% of the high signal level for waveform C3W1 (= suffix 8).

```
REFLevel8:LDEtection MANual  
REFLevel8:LMOde REL  
REFLevel8:RELative:MODE USER  
REFLevel8:RELative:LOWer 15  
REFLevel8:RELative:MIDDLE 50  
REFLevel8:RELative:UPPer 85
```

Automatic level detection, peak probability

Reference levels are set to the signal levels with the highest probability values for waveform C2W1 (= suffix 5).

```
REFLevel5:LDEtection Auto  
REFLevel5:AUTO:MODE PPRobability
```

21.3.2.2 Waveform Histograms

Creating and Reading Histograms

The example creates a histogram, activates two measurements (mean and standard deviation measurements of Histogram1), and queries the results of both measurements.

Command description in:

- [chapter 21.2.11.1, "General Settings"](#), on page 790
- ["Histogram Measurement"](#) on page 830
- [chapter 21.2.11.11, "Results"](#), on page 841

```
LAY:HIST:ADD 'Histogram1', C1W1, -2.5E-007, 2.5E-007, -1.32, 5.35, OFF, VERT
```

```
MEAS1 ON
MEAS1:HIST:SEL 'Histogram1'
MEAS1:CAT HIST
MEAS1:MAIN HME
```

```
MEAS2 ON
MEAS2:HIST:SEL 'Histogram1'
MEAS2:CAT HIST
MEAS2:MAIN HSTD
```

```
MEAS1:RES:ACT?
```

```
MEAS2:RES:ACT?
```

Exporting Histogram Data to File

The example writes the absolute data values of Histogram1 to C:\Histograms\Hist1.xml in XML format.

Command description in [chapter 21.2.15.3, "Waveform Histogram Export"](#), on page 926.

```
EXPoRT:HISToGRAM:SElect 'Histogram1'
EXPoRT:HISToGRAM:INCidence ABS
EXPoRT:HISToGRAM:NAME 'C:\Histograms\Hist1.xml'
EXPoRT:HISToGRAM:SAVE
```

Transferring Histogram Data

The example transfers the absolute values of Histogram1 to a controlling computer in ASCII format.

Command description in [chapter 21.2.15.3, "Waveform Histogram Export"](#), on page 926.

```
EXP:HIST:SEL 'Histogram1'
EXP:HIST:INC ABS
FRM ASC
```



```
EXP:HIST:DATA?
<--0,0,0,0,0,2037,5754804,4683496,3100169,2874565,...
```

21.3.2.3 Long Term Measurements

Exporting Long Term Measurement Data to File

The example writes the long term data of Meas1 to C:\Measurements\Meas1.csv in CSV format.

Command description in [chapter 21.2.15.4, "Long Term Measurement Results and Measurement Histogram Export"](#), on page 928.

```
EXPort:MEASurement:SEL MEAS1
EXPort:MEASurement:TYPE LONGTERM
EXPort:MEASurement:NAME 'C:\Measurements\Meas1.csv'
EXPort:MEASurement:SAVE
```

Transferring Long Term Measurement Data

The example transfers the long term data of Meas1 to a controlling computer in ASCII format.

Command description in [chapter 21.2.15.4, "Long Term Measurement Results and Measurement Histogram Export"](#), on page 928.

```
MEASurement:LTM ON
MEASurement:STAT ON
EXPort:MEASurement:SElect MEAS1
EXPort:MEASurement:TYPE LONGTERM
FORM ASC
EXPort:MEASurement:DATA?
<--50,0.24901185771,0.24731225296,0.24703557312,0.00069270717936,0,50,....
```

21.3.3 Mask Testing

21.3.3.1 Creating a user mask

Creates a new user mask "MyMask" with one inner segment, and turns the mask test on.

Command description in: [chapter 21.2.13, "Mask Testing"](#), on page 863.

```
MTEST:ADD 'MyMask'
MTEST:SEGM:ADD 'MyMask'
MTEST:SEGM:POIN:ADD 'MyMask', 0
MTEST:SEGM:POIN:X 'MyMask', 0, 0, -20e-9
MTEST:SEGM:POIN:Y 'MyMask', 0, 0, -0.1
MTEST:SEGM:POIN:ADD 'MyMask', 0
MTEST:SEGM:POIN:X 'MyMask', 0, 1, -20e-9
```

```

MTEST:SEGM:POIN:Y 'MyMask', 0, 1, 0.1
MTEST:SEGM:POIN:ADD 'MyMask', 0
MTEST:SEGM:POIN:X 'MyMask', 0, 2, 20e-9
MTEST:SEGM:POIN:Y 'MyMask', 0, 2, 0.1
MTEST:SEGM:POIN:ADD 'MyMask', 0
MTEST:SEGM:POIN:X 'MyMask', 0, 3, 20e-9
MTEST:SEGM:POIN:Y 'MyMask', 0, 3, -0.1
MTEST:SEGM:REG 'MyMask', 0, INNER
MTEST:STAT 'MyMask', ON

```

21.3.4 Search

21.3.4.1 Searching for a pulse of specified width

Search for positive pulses with pulse width $12 \pm 10 \mu\text{s}$ ($2 \mu\text{s}$ to $22 \mu\text{s}$).

Command description in: [chapter 21.2.14, "Search"](#), on page 878.

```

SEAR:ADD 'MySearch' // Create a new search
SEAR:TRIG:WIDT:STAT 'MySearch',1 // Configure search type
SEAR:SOUR 'MySearch',M1 // Configure search source - here Math1
SEAR:TRIG:WIDT:RANG 'MySearch',WITH // Configure search parameters
SEAR:TRIG:WIDT:WIDT 'MySearch',7e-6 // Configure search parameters
SEAR:TRIG:WIDT:DELT 'MySearch',1e-6 // Configure search parameters
SEAR:RES:LIM 'MySearch',1 // Set number of result lines in table to 1
SEAR:ALL 'MySearch' // Initiate search for all events

```

21.3.5 Data Management

- [Saving a Screenshot to File](#)..... 1131
- [Exporting Waveform Data to File](#)..... 1132
- [Exporting Measurement Results to File](#)..... 1135

21.3.5.1 Saving a Screenshot to File

Saves three display images in bmp format to the files `Print.bmp`, `Print_001.bmp`, and `Print_002.bmp` in the directory `C:\Temp`.

Command description in: [chapter 21.2.15.5, "Screenshots"](#), on page 929.

```

HCOP:DEST 'MMEM'
HCOP:DEV:LANG BMP
MMEM:NAME 'C:\Temp\Print.bmp'
HCOP:IMMediate
HCOP:IMM:NEXT
HCOP:IMM:NEXT

```

21.3.5.2 Exporting Waveform Data to File

Command description in:

- [chapter 21.2.15.2, "Waveform Data Export"](#), on page 920
- [chapter 21.2.15.1, "Instrument Settings"](#), on page 913
- [chapter 21.2.8.7, "History"](#), on page 771
- [Exporting a Single Waveform to XML File](#)..... 1132
- [Exporting Raw Data of a Single Waveform to BIN File](#)..... 1132
- [Exporting Raw Data of a Measurement Gate to BIN File](#)..... 1133
- [Exporting Interleaved x/y Data of a Single Waveform to CSV File](#)..... 1133
- [Exporting Interleaved x/y Data of a Zoom to CSV File](#)..... 1134
- [Exporting Multiple Running Acquisitions of a Single Waveform to XML File](#)..... 1134
- [Exporting a Single Acquisition of the History to BIN File](#)..... 1134
- [Exporting Multiple Acquisition of the History to XML File](#)..... 1135

Exporting a Single Waveform to XML File

Saves a single analog waveform completely to an XML file. Data logging is off.

```
EXPort:WAVeform:FASTexport ON
CHANnel:WAVeform1:STATe 1
RUNSingle
EXPort:WAVeform:SOURce C1W1
EXPort:WAVeform:SCOPE WFM
EXPort:WAVeform:NAME 'C:\Data\DataExportWfm_analog.xml'
EXPort:WAVeform:RAW OFF
EXPort:WAVeform:INCXvalues OFF
EXPort:WAVeform:DLOGging OFF
MMEM:DEL 'C:\Data\DataExportWfm_analog.*'
EXPort:WAVeform:SAVE
MMEM:DATA? 'C:\Data\DataExportWfm_analog.xml'
MMEM:DATA? 'C:\Data\DataExportWfm_analog.wfm.xml'
```

Exporting Raw Data of a Single Waveform to BIN File

Saves the data of a single analog waveform in integer 8 bit format (raw data) to a BIN file. Data logging is off.

Data conversion is described in "[Raw \(ADC direct\)](#)" on page 378.

```
EXPort:WAVeform:FASTexport ON
CHANnel:WAVeform1:STATe 1
RUNSingle
EXPort:WAVeform:SOURce C1W1
EXPort:WAVeform:SCOPE WFM
EXPort:WAVeform:NAME 'C:\Data\DataExportWfm_analog.bin'
EXPort:WAVeform:RAW ON
EXPort:WAVeform:INCXvalues OFF
EXPort:WAVeform:DLOGging OFF
MMEM:DEL 'C:\Data\DataExportWfm_analog.*'
EXPort:WAVeform:SAVE
```

```
MMEM:DATA? 'C:\Data\DataExportWfm_analog.bin'
MMEM:DATA? 'C:\Data\DataExportWfm_analog.wfm.bin'
```

Exporting Raw Data of a Measurement Gate to BIN File

Saves the data of a measurement gate in integer 8 bit format (raw data) to a BIN file. Data logging is off.

```
EXPort:WAVeform:FASTexport ON
CHANnel1:WAVeform1:STATe 1
MEASurement2:CATEgory AMPT
MEASurement2:MAIN MEAN
MEASurement2:ENABLe 1
MEASurement2:SOURce C1W1
MEASurement2:GATE:MODE ABS
MEASurement2:GATE:ABS:STARt -0.00012
MEASurement2:GATE:ABS:STOP -5e-06
MEASurement2:GATE:STATe On
EXPort:WAVeform:SOURce C1W1
EXPort:WAVeform:SCOPE GATE
EXPort:WAVeform:MEAS Meas2
RUNSingle
EXPort:WAVeform:NAME 'C:\Data\DataExportWfm_analog.bin'
EXPort:WAVeform:RAW ON
EXPort:WAVeform:INCXvalues OFF
EXPort:WAVeform:DLOGging OFF
MMEM:DEL 'C:\Data\DataExportWfm_analog.*'
EXPort:WAVeform:SAVE
MMEM:DATA? 'C:\Data\DataExportWfm_analog.bin'
MMEM:DATA? 'C:\Data\DataExportWfm_analog.wfm.bin'
```

Exporting Interleaved x/y Data of a Single Waveform to CSV File

Saves the x- and y- values of a single analog waveform to a CSV file. Data logging is off.

```
EXPort:WAVeform:FASTexport ON
CHANnel1:WAVeform1:STATe 1
RUNSingle
EXPort:WAVeform:SOURce C1W1
EXPort:WAVeform:SCOPE WFM
EXPort:WAVeform:NAME 'C:\Data\DataExportWfm_analog.csv'
EXPort:WAVeform:RAW OFF
EXPort:WAVeform:INCXvalues ON
EXPort:WAVeform:DLOGging OFF
MMEM:DEL 'C:\Data\DataExportWfm_analog.*'
EXPort:WAVeform:SAVE
MMEM:DATA? 'C:\Data\DataExportWfm_analog.csv'
MMEM:DATA? 'C:\Data\DataExportWfm_analog.wfm.csv'
```

Exporting Interleaved x/y Data of a Zoom to CSV File

Saves the x- and y- values that is displayed in a zoom diagram to a CSV file. Data logging is off.

```
EXPort:WAVeform:FASTexport ON
CHANnell:WAVeform1:STATe 1
LAYout:ZOOM:ADD 'Diagram1',HORIZONTAL,OFF,-0.00012,-5e-06,0.308,-0.092,'ExportAreaZoom'
RUNSingle
EXPort:WAVeform:SOURce C1W1
EXPort:WAVeform:SCOPE ZOOM
EXPort:WAVeform:ZOOM 'Diagram1', 'ExportAreaZoom'
EXPort:WAVeform:NAME 'C:\Data\DataExportWfm_analog.csv'
EXPort:WAVeform:RAW OFF
EXPort:WAVeform:INCXvalues ON
EXPort:WAVeform:DLOGging OFF
MMEM:DEL 'C:\Data\DataExportWfm_analog.*'
EXPort:WAVeform:SAVE
MMEM:DATA? 'C:\Data\DataExportWfm_analog.csv'
MMEM:DATA? 'C:\Data\DataExportWfm_analog.wfm.csv'
```

Exporting Multiple Running Acquisitions of a Single Waveform to XML File

Saves the data of 5 subsequent acquisitions of a single analog waveform to an XML file. Data logging is on.

```
EXPort:WAVeform:FASTexport ON
CHANnell:WAVeform1:STATe 1
EXPort:WAVeform:SOURce C1W1
EXPort:WAVeform:SCOPE WFM
EXPort:WAVeform:NAME 'C:\Data\DataExportWfm_analog.xml'
EXPort:WAVeform:RAW OFF
EXPort:WAVeform:INCXvalues OFF
ACQuire:COUNT 5
EXPort:WAVeform:DLOGging ON
MMEM:DEL 'C:\Data\DataExportWfm_analog.*'
RUNSingle
MMEM:DATA? 'C:\Data\DataExportWfm_analog.xml'
MMEM:DATA? 'C:\Data\DataExportWfm_analog.wfm.xml'
```

Exporting a Single Acquisition of the History to BIN File

Saves the oldest acquisition of the history to a BIN file. Data logging is off.

```
EXPort:WAVeform:FASTexport ON
CHANnell:WAVeform1:STATe 1
EXPort:WAVeform:SOURce C1W1
EXPort:WAVeform:SCOPE WFM
EXPort:WAVeform:NAME 'C:\Data\DataExportWfm_analog.bin'
EXPort:WAVeform:RAW OFF
EXPort:WAVeform:INCXvalues OFF
EXPort:WAVeform:DLOGging OFF
MMEM:DEL 'C:\Data\DataExportWfm_analog.*'
```

```

ACQuire:COUNT 5
RUNSingle
CHANnel:WAV1:HISTory:STATe ON
CHANnel:WAV1:HISTory:CURRent -4;*OPC
EXPort:WAVeform:SAVE
MME:DATA? 'C:\Data\DataExportWfm_analog.bin'
MME:DATA? 'C:\Data\DataExportWfm_analog.wfm.bin'

```

Exporting Multiple Acquisition of the History to XML File

Saves the data of 5 subsequent acquisitions of the history to an XML file. Data logging is on.

```

EXPort:WAVeform:FASTexport ON
CHANnel:WAVeform1:STATe 1
EXPort:WAVeform:SOURce C1W1
EXPort:WAVeform:SCOPE WFM
EXPort:WAVeform:NAME 'C:\Data\DataExportWfm_analog.xml'
EXPort:WAVeform:RAW OFF
EXPort:WAVeform:INCXvalues OFF
EXPort:WAVeform:DLOGging ON
MME:DEL 'C:\Data\DataExportWfm_analog.*'
ACQuire:COUNT 5
RUNSingle
CHANnel:WAV1:HISTory:STATe ON
CHANnel:WAV1:HISTory:STArT -4
CHANnel:WAV1:HISTory:STOP 0
CHANnel:WAV1:HISTory:REPLay OFF
CHANnel:WAV1:HISTory:PLAY
MME:DATA? 'C:\Data\DataExportWfm_analog.xml'
MME:DATA? 'C:\Data\DataExportWfm_analog.wfm.xml'

```

21.3.5.3 Exporting Measurement Results to File

See:

- ["Exporting Histogram Data to File"](#) on page 1129
- ["Transferring Histogram Data"](#) on page 1129
- ["Exporting Long Term Measurement Data to File"](#) on page 1130
- ["Transferring Long Term Measurement Data"](#) on page 1130

21.3.6 Power Analysis (Option R&S RTO-K31)

21.3.6.1 Auto Deskew

Configures the voltage and current probes for power measurements and executes the auto deskew.

Command description in [chapter 21.2.21.1, "General"](#), on page 1090 and [chapter 21.2.21.2, "Deskew"](#), on page 1091.



If the instrument refuses to accept `POWer` commands, activate the power mode using `:POWer:ENABle`.

```
*RST
//Activate two channels
:CHANnel1:STATe 1
:CHANnel2:STATe 1

//Activate power
:POWer:ENABle

//Select current and voltage sources
:POWer:SOURce:VOLTagel CHANnel1
:POWer:SOURce:CURRent1 CHANnel2

//Configure voltage probe on CH1 manually
//Not necessary if you use an active R&S voltage probe that is recognized by the instrument
:PROBe1:SETup:ATTenuation:MODE Manual
:PROBe:SETup:ATTenuation:DEFProbe ZD01a100
//selected high voltage differential probe 1:100

//Configure current probe on CH2 manually
//Always required because R&S current probes are not recognized automatically
PROBe2:SETup:ATTenuation:MODE Manual
PROBe2:SETup:ATTenuation:DEFProbe ZC20
//select 20MHz current probe ZC10 also possible

//Start deskew
//Overwrites the skew offset of CH2 (current probe), because :POWER:DESKew:RESet? == 1
//writes a user-defined preset file (UserDefinedPreset_AutoDeskew.dfl) and
//activates the user defined preset, because :POWER:DESKew:UDPRreset? == 1
:PoWer:DESKew:EXECute

//Check result
CHANnel2:SKEW:MAN?
CHANnel2:SKEW:TIME?
POWer:DESKew:TIME?
```

Effect of *RST and loading user-defined preset

Note that *RST resets the deskew values.

You can reload the deskew values as follows:

```
*RST
:POWer:ENABle
```

```
//Select voltage and current sources
:POWer:SOURce:VOLTagel CHANnel1
:POWer:SOURce:CURRent1 CHANnel2
//Reload deskew values
:POWer:DESKew:CURRent
//Load default saveset after FW restart
MMEM:RCL 'C:\Documents and Settings\All Users\Application Data\Rohde-Schwarz\
RTO\SaveSets\UserDefinedPreset_AutoDeskew.dfl'
```

21.3.6.2 Transient Response Measurement

Configures and executes a transient response measurement.

Command description in [chapter 21.2.21.15, "Transient Response"](#), on page 1118.

Make sure to configure and deskew the probes before the measurement, see [chapter 21.3.6.1, "Auto Deskew"](#), on page 1135.

```
//Activate power
:POWer:ENABle

//Expected smps frequency
:POW:TRANsient:FREQ 12500000

:POWer:TRANsient:AUToscale AUTO

:POWer:TRANsient:SIGHHigh 0.1
:POWer:TRANsient:SIGLow 0.025
:POWer:TRANsient:HYSTeresis 20

//Trigger channel
:POWer:TRANsient:TRGC CHAN2

//Edge trigger slope
:POWer:TRANsient:TRGS POS

//Trigger level
:POWer:TRANsient:TRGL 0.08

//Run measurement
:POWer:TRANsient:EXECute

//Reposition cursors to configure measurement points
CURSor2:X1Position -50e-9
CURSor2:X2Position 150e-9
CURSor3:X1Position -50e-9
CURSor3:X2Position 50e-9
CURSor4:X1Position -50e-9
CURSor4:X2Position 0

//Query cursors
```



```
:POWer:TRANsient:RESult? SETTling
:POWer:TRANsient:RESult? PEAKtime
:POWer:TRANsient:RESult? DELay
:POWer:TRANsient:RESult? RTIME
:POWer:TRANsient:RESult? OVERshoot

//Add to report
:Power:TRANsient:REPort:Add
```

22 Maintenance

The instrument does not need a periodic maintenance. Only the cleaning of the instrument is essential.

To protect the front panel and to transport the instrument to another workplace safely and easily, two accessories are provided:

- Soft case (R&S RTO-Z3, order number 1304.9118.02)
- Front cover (R&S RTO-Z1, order number 1304.9101.02)

Follow the instructions in the service manual and the safety instructions when exchanging modules or ordering spares. The order no. for spare parts is included in the service manual. The service manual includes further information particularly on troubleshooting, repair, exchange of modules (including adjustment of the OCXO oscillator) and alignment.

The "Board Detection/Maintenance dialog" box provides further information on your particular instrument configuration which may be helpful in case you require support.

The addresses of Rohde & Schwarz support centers can be found at <http://www.customersupport.rohde-schwarz.com>. A list of all service centers is available via <http://www.services.rohde-schwarz.com>.

22.1 Cleaning

The outside of the instrument can be cleaned sufficiently using a soft, lint-free dust cloth. Make sure that the fan openings are not obstructed.

WARNING

Shock hazard

Before cleaning the instrument, make sure that the instrument is switched off and disconnected from all power supplies.

NOTICE

Instrument damage caused by cleaning agents

Cleaning agents contain substances that may damage the instrument, for example cleaning agents that contain a solvent may damage the front panel labeling, plastic parts, or the display.

Never use cleaning agents such as solvents (thinners, acetone, etc), acids, bases, or other substances.

The outside of the instrument can be cleaned sufficiently using a soft, lint-free dust cloth.

NOTICE**Risk of instrument damage due to obstructed fans**

If the instrument is operated in dusty areas, the fans may become obstructed by dust or other particles in the process of time. Make sure to check and, if necessary, clean the fans regularly to ensure they operate properly at all times. If the instrument is run with obstructed fans for a longer period, it may become overheated which may cause damage.

22.2 Troubleshooting with RTOServiceReporter

The RTOServiceReporter creates and saves a complete bug report with all relevant setup, reporting, and log files. In case of a firmware failure, contact one of the Rohde & Schwarz support centers and send the report file for fast problem analysis.

1. On the R&S RTO display, open the "File" menu and tap "Minimize Application".
2. On the Windows desktop, execute the "RTOServiceReporter".
The system creates the report and saves it as zip file directly on the Windows desktop.
3. Send the report file to a Rohde & Schwarz support center.

22.3 Data Security

If you have to send the instrument to the service, or if the instrument is used in a secured environment, consider the document "Resolving Security Issues When Working in Secure Areas" that is delivered on the documentation CD-ROM and on the R&S RTO internet web page.

Instrument configuration data and user data are stored on a removable hard disk only. Thus it is sufficient to remove the hard disk before the instrument leaves a secured environment. Details are given in the document mentioned above.

22.4 Storing and Packing

The storage temperature range of the instrument is given in the data sheet. If the instrument is to be stored for a longer period of time, it must be protected against dust.

Repack the instrument as it was originally packed when transporting or shipping. The two protective foam plastic parts prevent the control elements and connectors from being damaged. The antistatic packing foil avoids any undesired electrostatic charging to occur.

If you do not use the original packaging, use a sturdy cardboard box of suitable size and provide for sufficient padding to prevent the instrument from slipping inside the package. Wrap antistatic packing foil around the instrument to protect it from electrostatic charging.

22.5 Performing a Selftest

The instrument selftest checks the hardware for correct operation. Perform the selftest if you suspect problems in hardware operation.

1. From the "File" menu, select "Selftest".
2. Tap "Selftest".

The test might take several minutes. The summary result is shown in the "State" field. In case you require support, you may be asked to provide this information.

22.6 Reference for Maintenance Settings

22.6.1 Board Detection/Maintenance

The "Board Detection/Maintenance" dialog box in the "File" menu provides service information for your R&S RTO. In case you require support, you may be asked to provide this information.

22.6.1.1 System Info

This tab provides general information on the hardware configuration, and indicates where system information can be found on the instrument.

22.6.1.2 Mainboard

This tab provides information on the mainboard configuration in your instrument.

22.6.1.3 Frontend

This tab provides information on the frontend configuration in your instrument.

22.6.1.4 Frontpanel

This tab provides information on the frontpanel module installed in your instrument.

22.6.1.5 MSO Option

This tab is only relevant if the MSO option R&S RTO-B1 is installed. The tab provides information on the MSO hardware module that is installed in your instrument.

22.6.1.6 Service

This tab allows the service personnel to enter a password that activates further service functions.

SCPI command: `DIAGnostic:SERVice:PWD` on page 1122

22.6.2 Selftest

The instrument selftest checks the hardware for correct operation. Perform the selftest if you suspect problems in hardware operation.

Selftest

Starts the selftest.

Remote command:

`*TST?` on page 672

State

Shows the summary result of the selftest: Pass or Fail.

Remote command:

`DIAGnostic:SERVice:STST:STATe?` on page 1122

Result

Opens a log file with detailed information on the selftest steps and hardware components operation. In case you require support, you may be asked to provide this information.

A Menu Overview

This section provides an overview of the menus together with a short description or link to the description.

- [File Menu](#)..... 1143
- [Horizontal Menu](#)..... 1144
- [Trigger Menu](#)..... 1144
- [Vertical Menu](#)..... 1145
- [Math Menu](#)..... 1145
- [Cursor Menu](#)..... 1145
- [Meas Menu](#)..... 1146
- [Masks Menu](#)..... 1146
- [Search Menu](#)..... 1146
- [Analysis Menu](#)..... 1147
- [Display Menu](#)..... 1147

A.1 File Menu

Menu item	Description	Corresponding key
Exit	Shuts down the firmware.	
Minimize Application	Shows the Windows desktop with the application icon of the R&S RTO firmware.	
Board Detection / Maintenance	chapter 22.6.1, "Board Detection/Maintenance" , on page 1141	
Mode	chapter 13.3.1, "Options in Beta State" , on page 410	MODE
Help	See "Getting Started" manual, chapter "Getting Information and Help"	HELP
Print	chapter 11.3, "Reference for PRINT Settings" , on page 387 chapter 11.1.1, "Configuring Printer Output and Printing" , on page 360	PRINT
Setup	chapter 12.2.1, "Setup" , on page 393	SETUP
Front Panel Setup	chapter 12.2.2, "Front Panel Setup" , on page 402	
Demo Board	For internal use only. Opens a setup dialog box for the demo board if a demo board is connected to the instrument.	
File	chapter 11.2, "Reference for FILE Settings" , on page 365	FILE
Selfalignment	chapter 12.2.3, "Self-alignment" , on page 403	
Selftest	chapter 22.6.2, "Selftest" , on page 1142	

A.2 Horizontal Menu

Menu item	Description	Corresponding key
Time Base	chapter 3.3.1.1, "Time Base" , on page 105	HORIZONTAL
Resolution	chapter 3.3.1.2, "Resolution" , on page 108	RES / REC LEN
Acquisition	chapter 3.3.1.3, "Acquisition" , on page 110	ACQUISITION
Ultra Segmentation	chapter 3.3.1.4, "Ultra Segmentation" , on page 113	
FFT Setup	chapter 8.3.3.1, "FFT Setup" , on page 305	
Reference	chapter 3.3.5.1, "Reference (OCXO, Option RTO-B4)" , on page 130	
Skew	chapter 3.3.5.2, "Skew" , on page 131	

A.3 Trigger Menu

Menu item	Description	Corresponding key
Trigger Events Setup	chapter 4.3.1, "Events and Trigger Types" , on page 138	TRIGGER
Trigger Slope	Opens a dialog box to select the slope or polarity, and the trigger type.	SLOPE
Trigger Mode	Selects the trigger mode in the submenu.	AUTO/NORMAL
Trigger Source	Opens a dialog box to select the trigger source. "Source" on page 139	SOURCE
Trigger Type	Selects the trigger type in the submenu.	
Force Trigger	Provokes an immediate single acquisition to confirm that a signal is available. Use the waveform display to determine how to trigger on it.	
Trigger Qualification	chapter 4.3.2, "Trigger Qualification" , on page 163	
Trigger Noise Reject	chapter 4.3.3, "Noise Reject" , on page 166	
Trigger Sequence	chapter 4.3.4, "Sequence" , on page 167	
Trigger Position	chapter 4.3.5, "Horizontal Position" , on page 171	
Trigger Control	chapter 4.3.6, "Control" , on page 173	
Digital Filter	chapter 3.3.4, "Digital Filter Setup" , on page 128	
Acquisition Info	Shows the current number of acquisitions that have been acquired.	

A.4 Vertical Menu

Menu item	Description	Corresponding key
Channels	chapter 3.3.2.1, "Channels" , on page 116	CH<N>
Power Calculation	chapter 3.3.2.2, "Power Calculation" , on page 118	
Probe Setup	chapter 3.3.3, "Probes" , on page 119	
Probe Maintenance	Opens a submenu: chapter 3.3.3.4, "Probe Attributes" , on page 127 chapter 3.3.3.5, "Calibration Results" , on page 128	
Digital Filter	chapter 3.3.4, "Digital Filter Setup" , on page 128	

A.5 Math Menu

Menu item	Description	Corresponding key
Math Setup	chapter 8.1.2, "Math Setup" , on page 288	MATH
FFT Setup	chapter 8.3.3.1, "FFT Setup" , on page 305	
FFT Magnitude/Phase	chapter 8.3.3.2, "FFT Magnitude/Phase" , on page 309	
FFT Gating	chapter 8.3.3.3, "FFT Gating" , on page 312	
Reference Waveform	Submenu: Setup, Scaling, Original Attributes: chapter 6.2, "Reference Waveforms" , on page 215	

A.6 Cursor Menu

Menu item	Description	Corresponding key
Setup	chapter 7.1.3.1, "Cursor Setup Tab" , on page 225	CURSOR
Style and Label	chapter 7.1.3.2, "Cursor Style and Label Tab" , on page 227	
Peak Search	chapter 7.1.3.3, "Peak Search Tab" , on page 228	

A.7 Meas Menu

Menu item	Description	Corresponding key
Setup	<ul style="list-style-type: none"> chapter 7.2.4.1, "Measurements Setup - General Settings", on page 261 chapter 7.2.4.2, "Measurements Setup - Amplitude/Time ", on page 264 chapter 7.2.4.4, "Measurements Setup - Eye ", on page 270 chapter 7.2.4.5, "Measurements Setup - Spectrum ", on page 271 chapter 7.2.4.6, "Measurements Setup - Histograms", on page 273 	MEAS Also activates the measurement
Gate/Display	chapter 7.2.4.8, "Measurements - Gate/Display Tab", on page 275	
Long Term/Statistics	chapter 7.2.4.9, "Measurements - Long Term/Track", on page 278	
Event Actions	chapter 7.2.4.11, "Measurements - Event Actions Tab", on page 282	
Histogram	chapter 7.2.4.13, "Histogram Setup", on page 285	
Reference Level	chapter 7.2.2.2, "Reference Level Settings", on page 246	
Advanced Delay Setup	Specific settings for delay measurement: "Advanced Delay Setup" on page 266	

A.8 Masks Menu

Menu item	Description	Corresponding key
Test Definition	chapter 9.3.1, "Test Definition", on page 325	MASKS Opens the last selected tab in the "Masks" dialog box.
Mask Definition	chapter 9.3.2.1, "Mask Definition: User Mask", on page 328	
Event Actions / Reset	chapter 9.3.3, "Event Actions /Reset ", on page 334	
Mask Display	chapter 9.3.4, "Mask Display", on page 336	

A.9 Search Menu

Menu item	Description	Corresponding key
Search Setup	chapter 10.2, "Search Setup", on page 340	SEARCH Opens the last selected tab in the "Search" dialog box.
Scope	chapter 10.3.1, "Gate Settings", on page 352	

Menu item	Description	Corresponding key
Result Presentation	chapter 10.4.1, "Result Presentation Settings" , on page 355	
Noise Reject	chapter 10.5.1, "Noise Reject Settings" , on page 358	

A.10 Analysis Menu

Menu item	Description	Corresponding key
Serial buses	Configuration a Opens a submenu: <ul style="list-style-type: none"> Configuration: chapter 14.1.1, "Configuration - General Settings", on page 420 Display: chapter 14.1.2, "Display", on page 420 	PROTOCOL Opens the last selected tab in the "Protocol" dialog box.
Parallel buses	Only if an MSO option is installed: chapter 15.3.1, "Parallel Buses - Configuration" , on page 518	

A.11 Display Menu

Menu item	Description	Corresponding key
Signal Colors / Persistence	chapter 5.1.3.1, "Signal Colors / Persistence" , on page 183	DISPLAY Opens the last selected tab in the "Display" dialog box.
Color Tables	chapter 5.1.3.2, "Color Tables" , on page 185 chapter 5.1.2.1, "Editing Waveform Colors" , on page 178	
Diagram Layout	chapter 5.1.3.3, "Diagram Layout" , on page 187	
XY-Diagram	chapter 5.3, "XY-diagram" , on page 204	
Zoom	chapter 5.2, "Zoom" , on page 193	ZOOM Also acitvates the zoom
Show history	Enables the history mode and opens the quick-access "History" dialog box. chapter 5.4, "History" , on page 207	HISTORY
History setup	Opens the "History" configuration dialog box without starting the history mode. chapter 5.4.3, "Reference for History" , on page 211	
Performance	Displays the current performance values of the instrument.	
Clear screen results	Deletes the current results in the result box together with the measurement and channel waveforms.	

Menu item	Description	Corresponding key
Toolbar	chapter 5.1.3.5, "Toolbar" , on page 192	
Signal Bar State	Switches the signal bar on or off. chapter 2.4.6, "Using the Signal bar" , on page 81	

List of Commands

*CAL?	669
*CLS	669
*ESE	669
*ESR?	669
*IDN?	669
*IST?	670
*OPC	670
*OPT?	670
*PCB	670
*PRE	671
*PSC	671
*RCL	671
*RST	671
*SAV	671
*SRE	672
*STB?	672
*TRG	672
*TST?	672
*WAI	672
ACQUIRE:ARESet:IMMediate	683
ACQUIRE:ARESet:MODE	684
ACQUIRE:ARESet:TIME	684
ACQUIRE:ARESet:WFMCOUNT	684
ACQUIRE:AVAILable?	771
ACQUIRE:COUNT	683
ACQUIRE:INTERpolate	681
ACQUIRE:MODE	681
ACQUIRE:POINTS:ARATE?	680
ACQUIRE:POINTS:AUTO	679
ACQUIRE:POINTS:MAXimum	679
ACQUIRE:POINTS[VALue]	680
ACQUIRE:RESolution	680
ACQUIRE:SEGMENTed:AUTOreplay	685
ACQUIRE:SEGMENTed:MAX	685
ACQUIRE:SEGMENTed:STATE	684
ACQUIRE:SRATE	680
AUToscale	679
BUS<m>:CAN:BITRate	981
BUS<m>:CAN:DATA:SOURce	980
BUS<m>:CAN:DATA:THReshold	980
BUS<m>:CAN:FCOUNT?	990
BUS<m>:CAN:FRAME<n>:ACKState?	991
BUS<m>:CAN:FRAME<n>:ACKValue?	992
BUS<m>:CAN:FRAME<n>:BSEPosition?	994
BUS<m>:CAN:FRAME<n>:BYTE<o>:STATE?	994
BUS<m>:CAN:FRAME<n>:BYTE<o>:VALue?	995
BUS<m>:CAN:FRAME<n>:CSState?	991

BUS<m>:CAN:FRAMe<n>:CSValue?	992
BUS<m>:CAN:FRAMe<n>:DATA?	991
BUS<m>:CAN:FRAMe<n>:DLCState?	991
BUS<m>:CAN:FRAMe<n>:DLCValue?	993
BUS<m>:CAN:FRAMe<n>:IDState?	991
BUS<m>:CAN:FRAMe<n>:IDType?	993
BUS<m>:CAN:FRAMe<n>:IDValue?	993
BUS<m>:CAN:FRAMe<n>:START?	990
BUS<m>:CAN:FRAMe<n>:STATus?	990
BUS<m>:CAN:FRAMe<n>:STOP?	990
BUS<m>:CAN:FRAMe<n>:SYMBol?	995
BUS<m>:CAN:FRAMe<n>:TYPE?	991
BUS<m>:CAN:JWIDth	982
BUS<m>:CAN:SAMPlepoint	982
BUS<m>:CAN:T1Segment	982
BUS<m>:CAN:T2Segment	982
BUS<m>:CAN:TECHnology	981
BUS<m>:CAN:TYPE	980
BUS<m>:FLXRy:BITRate	1015
BUS<m>:FLXRy:CHTYpe	1016
BUS<m>:FLXRy:FCOunt?	1027
BUS<m>:FLXRy:FRAMe<n>:ADID?	1029
BUS<m>:FLXRy:FRAMe<n>:CSState?	1030
BUS<m>:FLXRy:FRAMe<n>:CSValue?	1031
BUS<m>:FLXRy:FRAMe<n>:CYCount?	1030
BUS<m>:FLXRy:FRAMe<n>:DATA?	1029
BUS<m>:FLXRy:FRAMe<n>:FCState?	1031
BUS<m>:FLXRy:FRAMe<n>:FCValue?	1032
BUS<m>:FLXRy:FRAMe<n>:FLAGs?	1029
BUS<m>:FLXRy:FRAMe<n>:PAYLength?	1030
BUS<m>:FLXRy:FRAMe<n>:START?	1028
BUS<m>:FLXRy:FRAMe<n>:STATus?	1027
BUS<m>:FLXRy:FRAMe<n>:STOP?	1028
BUS<m>:FLXRy:FRAMe<n>:SYMBol?	1033
BUS<m>:FLXRy:FRAMe<n>:TYPE?	1028
BUS<m>:FLXRy:POLarity	1015
BUS<m>:FLXRy:PRDiff	1014
BUS<m>:FLXRy:PRLogic	1015
BUS<m>:FLXRy:PRSingle	1014
BUS<m>:FLXRy:SEHB	1016
BUS<m>:FLXRy:SOURce<n>	1013
BUS<m>:FLXRy:SRCType	1012
BUS<m>:FLXRy:THData	1014
BUS<m>:FLXRy:THENable	1013
BUS<m>:FLXRy:THReshold<n>	1013
BUS<m>:I2C:FCOunt?	950
BUS<m>:I2C:FRAMe<n>:AACcess?	950
BUS<m>:I2C:FRAMe<n>:ACcess?	951
BUS<m>:I2C:FRAMe<n>:ACOMplete?	951
BUS<m>:I2C:FRAMe<n>:ADBStart?	951

BUS<m>:I2C:FRAME<n>:ADDRESS?	952
BUS<m>:I2C:FRAME<n>:ADEVICE?	952
BUS<m>:I2C:FRAME<n>:AMODE?	952
BUS<m>:I2C:FRAME<n>:ASTART?	953
BUS<m>:I2C:FRAME<n>:BCOUNT?	955
BUS<m>:I2C:FRAME<n>:BYTE<o>:ACCESS?	955
BUS<m>:I2C:FRAME<n>:BYTE<o>:ACKSTART?	955
BUS<m>:I2C:FRAME<n>:BYTE<o>:COMPLETE?	956
BUS<m>:I2C:FRAME<n>:BYTE<o>:START?	956
BUS<m>:I2C:FRAME<n>:BYTE<o>:VALUE?	957
BUS<m>:I2C:FRAME<n>:DATA?	950
BUS<m>:I2C:FRAME<n>:RWBSTART?	953
BUS<m>:I2C:FRAME<n>:START?	954
BUS<m>:I2C:FRAME<n>:STATUS?	953
BUS<m>:I2C:FRAME<n>:STOP?	954
BUS<m>:I2C:FRAME<n>:SYMBOL?	958
BUS<m>:I2C:RWBIT	942
BUS<m>:I2C:SCL:SOURCE	940
BUS<m>:I2C:SCL:THRESHOLD	941
BUS<m>:I2C:SDA:SOURCE	940
BUS<m>:I2C:SDA:THRESHOLD	941
BUS<m>:I2C:TECHNOLOGY	941
BUS<m>:I2S:AVARIANT	1033
BUS<m>:I2S:BORDER	1038
BUS<m>:I2S:CHANNEL:LENGTH	1039
BUS<m>:I2S:CHANNEL:OFFSET	1038
BUS<m>:I2S:CHANNEL:ORDER	1037
BUS<m>:I2S:CHANNEL:TDMCOUNT	1038
BUS<m>:I2S:CLOCK:POLARITY	1034
BUS<m>:I2S:CLOCK:SOURCE	1034
BUS<m>:I2S:CLOCK:THRESHOLD	1036
BUS<m>:I2S:DATA:POLARITY	1036
BUS<m>:I2S:DATA:SOURCE	1035
BUS<m>:I2S:DATA:THRESHOLD	1037
BUS<m>:I2S:FCOUNT?	1044
BUS<m>:I2S:FOFFSET	1038
BUS<m>:I2S:FRAME<n>:LEFT:STATE?	1045
BUS<m>:I2S:FRAME<n>:LEFT:VALUE?	1045
BUS<m>:I2S:FRAME<n>:RIGHT:STATE?	1045
BUS<m>:I2S:FRAME<n>:RIGHT:VALUE?	1045
BUS<m>:I2S:FRAME<n>:START?	1044
BUS<m>:I2S:FRAME<n>:STATE?	1044
BUS<m>:I2S:FRAME<n>:STOP?	1044
BUS<m>:I2S:FRAME<n>:TDM<o>:STATE?	1045
BUS<m>:I2S:FRAME<n>:TDM<o>:VALUE?	1046
BUS<m>:I2S:TCOUPLING	1036
BUS<m>:I2S:TRACK:LEFT	1046
BUS<m>:I2S:TRACK:RIGHT	1046
BUS<m>:I2S:TRACK:TD1CH	1047
BUS<m>:I2S:TRACK:TD2CH	1047

BUS<m>:I2S:TRACK:TD3Ch.....	1047
BUS<m>:I2S:TRACK:TD4Ch.....	1047
BUS<m>:I2S:TRACK:TD5Ch.....	1047
BUS<m>:I2S:TRACK:TD6Ch.....	1047
BUS<m>:I2S:TRACK:TD7Ch.....	1047
BUS<m>:I2S:TRACK:TD8Ch.....	1047
BUS<m>:I2S:WLENgth.....	1037
BUS<m>:I2S:WSElect:POLarity.....	1035
BUS<m>:I2S:WSElect:SOURce.....	1034
BUS<m>:I2S:WSElect:THReshold.....	1036
BUS<m>:LABel.....	939
BUS<m>:LIN:BITRate.....	997
BUS<m>:LIN:DATA:SOURce.....	996
BUS<m>:LIN:DATA:THReshold.....	996
BUS<m>:LIN:FCOunt?.....	1005
BUS<m>:LIN:FRAME<n>:BYTE<o>:STATe?.....	1010
BUS<m>:LIN:FRAME<n>:BYTE<o>:VALue?.....	1010
BUS<m>:LIN:FRAME<n>:CSSTATe?.....	1009
BUS<m>:LIN:FRAME<n>:CSVALue?.....	1009
BUS<m>:LIN:FRAME<n>:DATA?.....	1007
BUS<m>:LIN:FRAME<n>:IDPVALue?.....	1008
BUS<m>:LIN:FRAME<n>:IDSTATe?.....	1007
BUS<m>:LIN:FRAME<n>:IDVALue?.....	1008
BUS<m>:LIN:FRAME<n>:START?.....	1006
BUS<m>:LIN:FRAME<n>:STATUs?.....	1006
BUS<m>:LIN:FRAME<n>:STOP?.....	1006
BUS<m>:LIN:FRAME<n>:SYMBol?.....	1011
BUS<m>:LIN:FRAME<n>:SYSTATe?.....	1009
BUS<m>:LIN:FRAME<n>:VERSion?.....	1007
BUS<m>:LIN:POLarity.....	998
BUS<m>:LIN:STANdard.....	998
BUS<m>:LIN:TECHnology.....	997
BUS<m>:PARAllel:BIT<n>:DESKew.....	1055
BUS<m>:PARAllel:BIT<n>:LABel.....	1055
BUS<m>:PARAllel:BIT<n>[:STATe].....	1052
BUS<m>:PARAllel:CLEar.....	1057
BUS<m>:PARAllel:CLOCK.....	1057
BUS<m>:PARAllel:CLON.....	1057
BUS<m>:PARAllel:CLSLope.....	1057
BUS<m>:PARAllel:DESOFFset.....	1055
BUS<m>:PARAllel:DISPlay:BTYP.....	1056
BUS<m>:PARAllel:DISPlay:SHBU.....	1056
BUS<m>:PARAllel:DISPlay:SHDI.....	1056
BUS<m>:PARAllel:HYSTEResis<n>.....	1054
BUS<m>:PARAllel:STATe.....	1052
BUS<m>:PARAllel:TECHnology.....	1053
BUS<m>:PARAllel:THCOupling.....	1054
BUS<m>:PARAllel:THReshold<n>.....	1052
BUS<m>:RESult.....	939
BUS<m>:SETRelevels.....	939

BUS<m>:SPI:BORDer.....	958
BUS<m>:SPI:FCOut?... ..	967
BUS<m>:SPI:FRAMe<n>:DATA?.....	967
BUS<m>:SPI:FRAMe<n>:STARt?.....	968
BUS<m>:SPI:FRAMe<n>:STATus?.....	967
BUS<m>:SPI:FRAMe<n>:STOP?.....	968
BUS<m>:SPI:FRAMe<n>:WCOut?... ..	969
BUS<m>:SPI:FRAMe<n>:WORD<o>:MISO?.....	970
BUS<m>:SPI:FRAMe<n>:WORD<o>:MOSI?.....	970
BUS<m>:SPI:FRAMe<n>:WORD<o>:STARt?.....	969
BUS<m>:SPI:FRAMe<n>:WORD<o>:STOP?.....	969
BUS<m>:SPI:FRCondition.....	962
BUS<m>:SPI:MISO:POLarity.....	960
BUS<m>:SPI:MISO:SOURce.....	960
BUS<m>:SPI:MISO:THReshold.....	962
BUS<m>:SPI:MOSI:POLarity.....	961
BUS<m>:SPI:MOSI:SOURce.....	961
BUS<m>:SPI:MOSI:THReshold.....	962
BUS<m>:SPI:SCLK:SOURce.....	959
BUS<m>:SPI:SCLK:THReshold.....	962
BUS<m>:SPI:SSElect:POLarity.....	960
BUS<m>:SPI:SSElect:SOURce.....	959
BUS<m>:SPI:SSElect:THReshold.....	962
BUS<m>:SPI:TECHnology.....	961
BUS<m>:SPI:TIMEout.....	963
BUS<m>:SPI:WSIZE.....	959
BUS<m>:SYMBols.....	957
BUS<m>:SYMBols.....	995
BUS<m>:SYMBols.....	1011
BUS<m>:SYMBols.....	1032
BUS<m>:TYPE.....	938
BUS<m>:UART:BAUDrate.....	973
BUS<m>:UART:BITime.....	974
BUS<m>:UART:BITRate.....	973
BUS<m>:UART:PARity.....	973
BUS<m>:UART:POLarity.....	974
BUS<m>:UART:RX:SOURce.....	971
BUS<m>:UART:RX:THReshold.....	972
BUS<m>:UART:SBIT.....	974
BUS<m>:UART:SSIZE.....	975
BUS<m>:UART:TECHnology.....	972
BUS<m>:UART:TX:SOURce.....	971
BUS<m>:UART:TX:THReshold.....	972
BUS<m>:UART:WORD<n>:COUNT?.....	978
BUS<m>:UART:WORD<n>:RXValue?.....	978
BUS<m>:UART:WORD<n>:SOURce?.....	978
BUS<m>:UART:WORD<n>:STARt?.....	979
BUS<m>:UART:WORD<n>:STATe?.....	979
BUS<m>:UART:WORD<n>:TXValue?.....	978
BUS<m>[:STATE].....	938

BUSFormat.....	939
CALCulate:MATH<m>:ARITHmatics.....	848
CALCulate:MATH<m>:DATA:HEADer?.....	862
CALCulate:MATH<m>:DATA:STYPe?.....	861
CALCulate:MATH<m>:DATA[:VALues]?.....	862
CALCulate:MATH<m>:FFT:BANDwidth[:RESolution]:ADJusted?.....	853
CALCulate:MATH<m>:FFT:BANDwidth[:RESolution]:AUTO.....	854
CALCulate:MATH<m>:FFT:BANDwidth[:RESolution]:RATio.....	854
CALCulate:MATH<m>:FFT:BANDwidth[:RESolution][:VALue].....	854
CALCulate:MATH<m>:FFT:CFRequency.....	852
CALCulate:MATH<m>:FFT:FRAMe:ARITHmatics.....	855
CALCulate:MATH<m>:FFT:FRAMe:COVerge?.....	856
CALCulate:MATH<m>:FFT:FRAMe:MAXCount.....	856
CALCulate:MATH<m>:FFT:FRAMe:OFACtor.....	856
CALCulate:MATH<m>:FFT:FULLspan.....	853
CALCulate:MATH<m>:FFT:GATE:ABSolute:START.....	857
CALCulate:MATH<m>:FFT:GATE:ABSolute:STOP.....	857
CALCulate:MATH<m>:FFT:GATE:COUPling.....	854
CALCulate:MATH<m>:FFT:GATE:MODE.....	857
CALCulate:MATH<m>:FFT:GATE:RELAtive:START.....	858
CALCulate:MATH<m>:FFT:GATE:RELAtive:STOP.....	858
CALCulate:MATH<m>:FFT:GATE:SHOW.....	858
CALCulate:MATH<m>:FFT:GATE:ZCOUpling.....	858
CALCulate:MATH<m>:FFT:GATE[:STATe].....	859
CALCulate:MATH<m>:FFT:MAGNitude:LEVel.....	859
CALCulate:MATH<m>:FFT:MAGNitude:RANGe.....	859
CALCulate:MATH<m>:FFT:MAGNitude:SCALe.....	860
CALCulate:MATH<m>:FFT:PHASe:SCALe.....	860
CALCulate:MATH<m>:FFT:PHASe:SUPPReSSion.....	860
CALCulate:MATH<m>:FFT:PHASe:THReshold.....	861
CALCulate:MATH<m>:FFT:PHASe:UNWRap.....	861
CALCulate:MATH<m>:FFT:SPAN.....	853
CALCulate:MATH<m>:FFT:START.....	850
CALCulate:MATH<m>:FFT:STOP.....	850
CALCulate:MATH<m>:FFT:WINDow:TYPE.....	851
CALCulate:MATH<m>:STATe.....	847
CALCulate:MATH<m>:VERTical:OFFSet.....	848
CALCulate:MATH<m>:VERTical:RANGe.....	849
CALCulate:MATH<m>:VERTical:SCALe.....	849
CALCulate:MATH<m>[:EXPRession][:DEFine].....	847
CDR:HARDware:BITRate.....	1083
CDR:HARDware:ESLope.....	1084
CDR:HARDware:PLL:BWIDth.....	1084
CDR:HARDware:PLL:DAMPing.....	1085
CDR:HARDware:PLL:ORDer.....	1084
CDR:HARDware:PLL:RELBwidth.....	1084
CDR:HARDware:SOURce.....	1083
CDR:HARDware:UIOFFset.....	1086
CDR:SOFTware<m>:ALGorithm.....	1080
CDR:SOFTware<m>:BITRate.....	1080

CDR:SOFTware<m>:ESLope.....	1081
CDR:SOFTware<m>:PLL:BWIDth.....	1082
CDR:SOFTware<m>:PLL:DAMPing.....	1083
CDR:SOFTware<m>:PLL:ORDer.....	1082
CDR:SOFTware<m>:PLL:RELBwidth.....	1082
CDR:SOFTware<m>:RESults.....	1081
CDR:SOFTware<m>:SYNC.....	1081
CHANnel<m>:BANDwidth.....	688
CHANnel<m>:COUPling.....	686
CHANnel<m>:DIGFilter:CUToff.....	699
CHANnel<m>:DIGFilter:STATe.....	699
CHANnel<m>:EATScale.....	693
CHANnel<m>:EATTenuation.....	694
CHANnel<m>:EXPortstate.....	922
CHANnel<m>:GND.....	686
CHANnel<m>:IMPedance.....	688
CHANnel<m>:IQ:CFRequency.....	1071
CHANnel<m>:IQ:DATA:HEADer?.....	1073
CHANnel<m>:IQ:DATA[:VALues]?.....	1073
CHANnel<m>:IQ:INPMode.....	1070
CHANnel<m>:IQ:INPTyPe.....	1070
CHANnel<m>:IQ:SBIF.....	1072
CHANnel<m>:IQ:SBRF.....	1072
CHANnel<m>:OFFSet.....	688
CHANnel<m>:OVERload.....	689
CHANnel<m>:POSition.....	687
CHANnel<m>:RANGe.....	687
CHANnel<m>:SCALE.....	686
CHANnel<m>:SKEW:MANual.....	700
CHANnel<m>:SKEW:TIME.....	701
CHANnel<m>:STATe.....	685
CHANnel<m>[:WAVeform<n>]:ARITHmatics.....	683
CHANnel<m>[:WAVeform<n>]:DATA:HEADer?.....	689
CHANnel<m>[:WAVeform<n>]:DATA[:VALues]?.....	690
CHANnel<m>[:WAVeform<n>]:HISTory:CURRent.....	771
CHANnel<m>[:WAVeform<n>]:HISTory:PLAY.....	773
CHANnel<m>[:WAVeform<n>]:HISTory:REPLay.....	773
CHANnel<m>[:WAVeform<n>]:HISTory:STARt.....	772
CHANnel<m>[:WAVeform<n>]:HISTory:STOP.....	772
CHANnel<m>[:WAVeform<n>]:HISTory:TPACq.....	773
CHANnel<m>[:WAVeform<n>]:HISTory:TSABsolute?.....	774
CHANnel<m>[:WAVeform<n>]:HISTory:TSDate?.....	774
CHANnel<m>[:WAVeform<n>]:HISTory:TSRelative?.....	774
CHANnel<m>[:WAVeform<n>]:HISTory[:STATe].....	771
CHANnel<m>[:WAVeform<n>]:TYPE.....	682
CHANnel<m>[:WAVeform<n>][:STATe].....	682
CURSor<m>:AOFF.....	782
CURSor<m>:FUNCTion.....	783
CURSor<m>:MAXimum:LEFT.....	788
CURSor<m>:MAXimum:NEXT.....	788

CURSor<m>:MAXimum:RIGHT.....	788
CURSor<m>:MAXimum[:PEAK].....	788
CURSor<m>:PEXCursion.....	789
CURSor<m>:SOURce.....	784
CURSor<m>:STATe.....	783
CURSor<m>:TRACking[:STATe].....	783
CURSor<m>:X1ENvelope.....	786
CURSor<m>:X1Position.....	784
CURSor<m>:X2ENvelope.....	786
CURSor<m>:X2Position.....	784
CURSor<m>:XCoupling.....	784
CURSor<m>:XDELta:INVerse?.....	787
CURSor<m>:XDELta[:VALue]?.....	787
CURSor<m>:Y1Position.....	785
CURSor<m>:Y2Position.....	785
CURSor<m>:YCOupling.....	785
CURSor<m>:YDELta:SLOPe.....	788
CURSor<m>:YDELta[:VALue]?.....	787
DIAGnostic:SERVice:COMPuTername.....	935
DIAGnostic:SERVice:FWVersion?.....	935
DIAGnostic:SERVice:PARTnumber.....	936
DIAGnostic:SERVice:PWD.....	1122
DIAGnostic:SERVice:SERialnumber?.....	936
DIAGnostic:SERVice:STST:EXECute.....	1122
DIAGnostic:SERVice:STST:STATe?.....	1122
DIGital<m>:DATA:HEADer?.....	1069
DIGital<m>:DATA[:VALues]?.....	1069
DIGital<m>:DESKew.....	1051
DIGital<m>:DISPlay.....	1048
DIGital<m>:HYSTEResis.....	1050
DIGital<m>:LABel.....	1051
DIGital<m>:TECHnology.....	1049
DIGital<m>:THCoupling.....	1050
DIGital<m>:THReshold.....	1049
DISPlay:COLor:PALette:ADD.....	750
DISPlay:COLor:PALette:COUNT?.....	750
DISPlay:COLor:PALette:POINT:ADD.....	750
DISPlay:COLor:PALette:POINT:COUNT?.....	751
DISPlay:COLor:PALette:POINT:INSert.....	750
DISPlay:COLor:PALette:POINT:REMOve.....	751
DISPlay:COLor:PALette:POINT[:VALue].....	751
DISPlay:COLor:PALette:REMOve.....	750
DISPlay:COLor:SIGNal<m>:ASSign.....	749
DISPlay:COLor:SIGNal<m>:USE.....	749
DISPlay:DIAGram:CROSShair.....	752
DISPlay:DIAGram:FINegrid.....	752
DISPlay:DIAGram:GRID.....	752
DISPlay:DIAGram:LABels.....	753
DISPlay:DIAGram:STYLe.....	749
DISPlay:DIAGram:TITLe.....	753

DISPlay:DIAGram:YFIxed.....	753
DISPlay:INTensity.....	748
DISPlay:PERsistence:INFinite.....	748
DISPlay:PERsistence:RESet.....	748
DISPlay:PERsistence:TIME.....	748
DISPlay:PERsistence[:STATe].....	748
DISPlay:RESultboxes:DEFaultpos.....	755
DISPlay:SIGBar:COLor:BORDER.....	754
DISPlay:SIGBar:COLor:FILL.....	755
DISPlay:SIGBar:HIDE:HEAD.....	754
DISPlay:SIGBar:HIDE:TIME.....	754
DISPlay:SIGBar:HIDE:TRANsparency.....	754
DISPlay:SIGBar:HIDE[:AUTO].....	754
DISPlay:SIGBar:POSition.....	753
DISPlay:SIGBar[:STATe].....	753
DISPlay:SIGNal:LABel:ADD.....	758
DISPlay:SIGNal:LABel:HORIZontal:ABSolute:POSition.....	760
DISPlay:SIGNal:LABel:HORIZontal:RELative:POSition.....	761
DISPlay:SIGNal:LABel:POSMode.....	759
DISPlay:SIGNal:LABel:REMOve.....	759
DISPlay:SIGNal:LABel:TEXT.....	759
DISPlay:SIGNal:LABel:VERTical:ABSolute:POSition.....	760
DISPlay:SIGNal:LABel:VERTical:RELative:POSition.....	761
DISPlay:TRIGger:LINes.....	702
EXPort:HISTogram:DATA?.....	927
EXPort:HISTogram:INCidence.....	927
EXPort:HISTogram:NAME.....	927
EXPort:HISTogram:SAVE.....	927
EXPort:HISTogram:SElect.....	926
EXPort:MEASurement:DATA?.....	929
EXPort:MEASurement:NAME.....	928
EXPort:MEASurement:SAVE.....	929
EXPort:MEASurement:SElect.....	928
EXPort:MEASurement:TYPE.....	928
EXPort:WAVEform:CURSorset.....	923
EXPort:WAVEform:DISPlayoff.....	926
EXPort:WAVEform:DLOGging.....	924
EXPort:WAVEform:FASTexport.....	926
EXPort:WAVEform:INCXvalues.....	925
EXPort:WAVEform:MEAS.....	924
EXPort:WAVEform:MULTichannel.....	921
EXPort:WAVEform:NAME.....	921
EXPort:WAVEform:RAW.....	925
EXPort:WAVEform:SAVE.....	921
EXPort:WAVEform:SCOPE.....	922
EXPort:WAVEform:SOURce.....	921
EXPort:WAVEform:STARt.....	923
EXPort:WAVEform:STOP.....	923
EXPort:WAVEform:ZOOM.....	923
FORMat:BPATtern.....	674

FORMat[:DATA].....	673
HCOPY:CMAP<m>:DEFault.....	932
HCOPY:DEStination<1..2>.....	930
HCOPY:DEVice<m>:COLor.....	931
HCOPY:DEVice<m>:INVerse.....	931
HCOPY:DEVice<m>:LANGUage.....	931
HCOPY:IMMediate<m>:NEXT.....	932
HCOPY:IMMediate<m>[:DUM].....	932
HCOPY:PAGE:ORlentation<1..2>.....	931
IQ:BWIDth?.....	1071
IQ:RBWIDth.....	1070
IQ:RELENgth.....	1071
IQ:SRATe.....	1071
IQ:STATe.....	1069
LAYout:ADD.....	755
LAYout:HISTogram:ADD.....	825
LAYout:HISTogram:HORIZ:ABSolute:START.....	827
LAYout:HISTogram:HORIZ:ABSolute:STOP.....	827
LAYout:HISTogram:HORIZ:MODE.....	827
LAYout:HISTogram:HORIZ:RELative:START.....	827
LAYout:HISTogram:HORIZ:RELative:STOP.....	828
LAYout:HISTogram:MODE.....	826
LAYout:HISTogram:REMove.....	829
LAYout:HISTogram:RESet.....	829
LAYout:HISTogram:SOURce.....	826
LAYout:HISTogram:VERTical:ABSolute:START.....	828
LAYout:HISTogram:VERTical:ABSolute:STOP.....	828
LAYout:HISTogram:VERTical:MODE.....	828
LAYout:HISTogram:VERTical:RELative:START.....	829
LAYout:HISTogram:VERTical:RELative:STOP.....	829
LAYout:REMove.....	756
LAYout:SHOW.....	756
LAYout:SIGNal:ASSign.....	756
LAYout:SIGNal:AXIS.....	757
LAYout:SIGNal:UNASsign.....	757
LAYout:ZOOM:ADD.....	762
LAYout:ZOOM:ADDCoupled.....	762
LAYout:ZOOM:HORIZ:ABSolute:POSition.....	763
LAYout:ZOOM:HORIZ:ABSolute:SPAN.....	764
LAYout:ZOOM:HORIZ:ABSolute:START.....	764
LAYout:ZOOM:HORIZ:ABSolute:STOP.....	764
LAYout:ZOOM:HORIZ:MODE.....	763
LAYout:ZOOM:HORIZ:RELative:POSition.....	765
LAYout:ZOOM:HORIZ:RELative:SPAN.....	765
LAYout:ZOOM:HORIZ:RELative:START.....	765
LAYout:ZOOM:HORIZ:RELative:STOP.....	766
LAYout:ZOOM:ONEDiagram.....	763
LAYout:ZOOM:POSCoupling.....	763
LAYout:ZOOM:REMove.....	769
LAYout:ZOOM:VERTical:ABSolute:POSition.....	766

LAYout:ZOOM:VERTical:ABSolute:SPAN.....	767
LAYout:ZOOM:VERTical:ABSolute:START.....	767
LAYout:ZOOM:VERTical:ABSolute:STOP.....	767
LAYout:ZOOM:VERTical:MODE.....	766
LAYout:ZOOM:VERTical:RELative:POSition.....	767
LAYout:ZOOM:VERTical:RELative:SPAN.....	768
LAYout:ZOOM:VERTical:RELative:START.....	768
LAYout:ZOOM:VERTical:RELative:STOP.....	768
MEASurement<m>:ADDITIONal.....	794
MEASurement<m>:AMPTime:ALEVel.....	814
MEASurement<m>:AMPTime:CLCK<n>:LSElect.....	816
MEASurement<m>:AMPTime:CSLope.....	816
MEASurement<m>:AMPTime:DATA<n>:LSElect.....	817
MEASurement<m>:AMPTime:DElay<n>:DIRection.....	814
MEASurement<m>:AMPTime:DElay<n>:ECOUNT.....	815
MEASurement<m>:AMPTime:DElay<n>:LSElect.....	815
MEASurement<m>:AMPTime:DElay<n>:SLOPe.....	815
MEASurement<m>:AMPTime:DTOTrigger<n>:LSElect.....	817
MEASurement<m>:AMPTime:DTOTrigger<n>:SLOPe.....	817
MEASurement<m>:AMPTime:ESLope.....	816
MEASurement<m>:AMPTime:LCHeck<n>:LOWer:LIMit.....	818
MEASurement<m>:AMPTime:LCHeck<n>:LOWer:MARGin.....	818
MEASurement<m>:AMPTime:LCHeck<n>:UPPer:LIMit.....	818
MEASurement<m>:AMPTime:LCHeck<n>:UPPer:MARGin.....	818
MEASurement<m>:AMPTime:LCHeck<n>:VALid.....	818
MEASurement<m>:AMPTime:PSLope.....	814
MEASurement<m>:AMPTime:PTCount.....	815
MEASurement<m>:AOFF.....	795
MEASurement<m>:AON.....	795
MEASurement<m>:ARES?.....	842
MEASurement<m>:CATegory.....	792
MEASurement<m>:CLear.....	796
MEASurement<m>:DEThreshold.....	813
MEASurement<m>:DISPlay:HISTogram.....	835
MEASurement<m>:DISPlay:LEVels.....	834
MEASurement<m>:DISPlay:RESults.....	834
MEASurement<m>:DISPlay:STYLe.....	834
MEASurement<m>:ENVSelect.....	813
MEASurement<m>:EYEJitter:LCHeck<n>:LOWer:LIMit.....	820
MEASurement<m>:EYEJitter:LCHeck<n>:LOWer:MARGin.....	821
MEASurement<m>:EYEJitter:LCHeck<n>:UPPer:LIMit.....	820
MEASurement<m>:EYEJitter:LCHeck<n>:UPPer:MARGin.....	821
MEASurement<m>:EYEJitter:LCHeck<n>:VALid.....	820
MEASurement<m>:FSRC.....	791
MEASurement<m>:GATE:ABSolute:START.....	844
MEASurement<m>:GATE:ABSolute:STOP.....	844
MEASurement<m>:GATE:MODE.....	844
MEASurement<m>:GATE:NOISe.....	845
MEASurement<m>:GATE:RELative:START.....	844
MEASurement<m>:GATE:RELative:STOP.....	844

MEASurement<m>:GATE:SHOW.....	845
MEASurement<m>:GATE:ZCOupling.....	845
MEASurement<m>:GATE[:STATe].....	844
MEASurement<m>:HISTogram:LCHeck<n>:LOWer:LIMit.....	833
MEASurement<m>:HISTogram:LCHeck<n>:LOWer:MARGin.....	833
MEASurement<m>:HISTogram:LCHeck<n>:UPPer:LIMit.....	833
MEASurement<m>:HISTogram:LCHeck<n>:UPPer:MARGin.....	833
MEASurement<m>:HISTogram:LCHeck<n>:VALid.....	832
MEASurement<m>:HISTogram:PROBability:LIMit.....	832
MEASurement<m>:HISTogram:PROBability:TYPE.....	831
MEASurement<m>:HISTogram:SElect.....	831
MEASurement<m>:JITTer:CCSLope.....	1076
MEASurement<m>:JITTer:CDRMode.....	1078
MEASurement<m>:JITTer:COFFset.....	1077
MEASurement<m>:JITTer:PULSe.....	1077
MEASurement<m>:JITTer:SKWRelation.....	1079
MEASurement<m>:JITTer:SKWSlope.....	1079
MEASurement<m>:JITTer:SOURce<n>:TIESlope.....	1078
MEASurement<m>:LCHeck.....	835
MEASurement<m>:LTMeas:COUNT.....	839
MEASurement<m>:LTMeas:ENVSensor:STATe.....	840
MEASurement<m>:LTMeas:TIME.....	840
MEASurement<m>:LTMeas[:STATe].....	839
MEASurement<m>:MAIN.....	792
MEASurement<m>:MNOMeas.....	796
MEASurement<m>:MULtiple.....	796
MEASurement<m>:ONViolation:ACQStop.....	846
MEASurement<m>:ONViolation:BEEP.....	846
MEASurement<m>:ONViolation:PRINt.....	846
MEASurement<m>:ONViolation:WFMSave.....	846
MEASurement<m>:REFLevel:RESult:BINNer?.....	809
MEASurement<m>:REFLevel:RESult:BOUter?.....	810
MEASurement<m>:REFLevel:RESult:LOWer?.....	809
MEASurement<m>:REFLevel:RESult:MIDdle?.....	809
MEASurement<m>:REFLevel:RESult:SIGHigh?.....	809
MEASurement<m>:REFLevel:RESult:SIGLow?.....	809
MEASurement<m>:REFLevel:RESult:TINNer?.....	810
MEASurement<m>:REFLevel:RESult:TOUter?.....	810
MEASurement<m>:REFLevel:RESult:UPPer?.....	809
MEASurement<m>:RESult:AVG?.....	842
MEASurement<m>:RESult:EVTCount?.....	842
MEASurement<m>:RESult:NPEak?.....	842
MEASurement<m>:RESult:PPEak?.....	842
MEASurement<m>:RESult:RMS?.....	842
MEASurement<m>:RESult:STDDev?.....	842
MEASurement<m>:RESult:WFMCount?.....	842
MEASurement<m>:RESult[:ACTual]?.....	842
MEASurement<m>:SOURce.....	790
MEASurement<m>:SPECtrum:CPOWer:BANDwidth.....	822
MEASurement<m>:SPECtrum:CPOWer:CFRequency.....	823

MEASurement<m>:SPEctrum:LCHeck<n>:LOWer:LIMit.....	824
MEASurement<m>:SPEctrum:LCHeck<n>:LOWer:MARGin.....	824
MEASurement<m>:SPEctrum:LCHeck<n>:UPPer:LIMit.....	824
MEASurement<m>:SPEctrum:LCHeck<n>:UPPer:MARGin.....	824
MEASurement<m>:SPEctrum:LCHeck<n>:VALid.....	823
MEASurement<m>:SPEctrum:NDBDown.....	823
MEASurement<m>:SPEctrum:NREJect.....	823
MEASurement<m>:SPEctrum:OBANdwidth.....	822
MEASurement<m>:SSRC.....	791
MEASurement<m>:STATistics:HISTogram.....	836
MEASurement<m>:STATistics:MODE.....	836
MEASurement<m>:STATistics:RCOunt.....	837
MEASurement<m>:STATistics:RESet.....	838
MEASurement<m>:STATistics:RMEascount.....	837
MEASurement<m>:STATistics:RTIME.....	837
MEASurement<m>:STATistics[:ENABle].....	836
MEASurement<m>:TRACk:DATA:HEADer?.....	841
MEASurement<m>:TRACk:DATA:HEADer?.....	1047
MEASurement<m>:TRACk:DATA:STYPe?.....	841
MEASurement<m>:TRACk:DATA:STYPe?.....	1048
MEASurement<m>:TRACk:DATA[:VALues]?.....	841
MEASurement<m>:TRACk:DATA[:VALues]?.....	1048
MEASurement<m>:TRACk[:STATe].....	840
MEASurement<m>:TRACk[:STATe].....	1047
MEASurement<m>:VERTical:AUTO.....	838
MEASurement<m>:VERTical:CONT.....	838
MEASurement<m>:VERTical:OFFSet.....	838
MEASurement<m>:VERTical:SCALE.....	839
MEASurement<m>[:ENABle].....	790
MMEMory:ATTRibute.....	918
MMEMory:CATalog:LENGth?.....	916
MMEMory:CATalog?.....	915
MMEMory:CDIRectory.....	915
MMEMory:COPI.....	916
MMEMory:DATA.....	918
MMEMory:DCATalog:LENGth?.....	914
MMEMory:DCATalog?.....	914
MMEMory:DELeTe.....	917
MMEMory:DRIVes?.....	914
MMEMory:LOAD:STATe.....	920
MMEMory:MDIRectory.....	915
MMEMory:MOVE.....	917
MMEMory:MSIS.....	914
MMEMory:NAME.....	930
MMEMory:RCL.....	919
MMEMory:RDIRectory.....	915
MMEMory:SAV.....	919
MMEMory:STORe:STATe.....	919
MTESt:ADD.....	863
MTESt:CONDition.....	864

MTESt:CTYPE.....	865
MTESt:EYEMask:BOFFset.....	1089
MTESt:EYEMask:HEIGht<m>[:VALue].....	1087
MTESt:EYEMask:HPERiod.....	1088
MTESt:EYEMask:HPOStion.....	1089
MTESt:EYEMask:MSKBottom.....	1088
MTESt:EYEMask:MSKLeft.....	1088
MTESt:EYEMask:MSKRight.....	1088
MTESt:EYEMask:MSKTop.....	1088
MTESt:EYEMask:TBSYmmetric.....	1089
MTESt:EYEMask:TBWidth.....	1089
MTESt:EYEMask:TOFFset.....	1089
MTESt:EYEMask:TYPE.....	1087
MTESt:EYEMask:VPOStion.....	1090
MTESt:EYEMask:WIDTh<m>[:VALue].....	1087
MTESt:FILE:DELeTe.....	867
MTESt:FILE:NAME.....	866
MTESt:FILE:OPEN.....	866
MTESt:FILE:SAVE.....	866
MTESt:ONViolation:BEEP.....	874
MTESt:ONViolation:PRINt.....	875
MTESt:ONViolation:SAVewaveform.....	875
MTESt:ONViolation:STOP.....	875
MTESt:REFWfm.....	872
MTESt:REMOve.....	863
MTESt:RESult:COUNt:FAILures?.....	877
MTESt:RESult:COUNt:FWAVEforms?.....	877
MTESt:RESult:COUNt:REMAining?.....	876
MTESt:RESult:COUNt:WAVEforms?.....	876
MTESt:RESult:FRATe?.....	877
MTESt:RESult:STATe?.....	876
MTESt:RESult[:RESult]?.....	876
MTESt:RST.....	864
MTESt:SEGment:ADD.....	868
MTESt:SEGment:COUNt?.....	868
MTESt:SEGment:INSert.....	868
MTESt:SEGment:POINt:ADD.....	869
MTESt:SEGment:POINt:COUNt?.....	870
MTESt:SEGment:POINt:INSert.....	869
MTESt:SEGment:POINt:REMOve.....	869
MTESt:SEGment:POINt:X.....	870
MTESt:SEGment:POINt:Y.....	870
MTESt:SEGment:REGion.....	868
MTESt:SEGment:REMOve.....	868
MTESt:SEGment:RESCale:RECalculate.....	871
MTESt:SEGment:RESCale:XFACTOR.....	871
MTESt:SEGment:RESCale:XOFFset.....	871
MTESt:SEGment:RESCale:YFACTOR.....	871
MTESt:SEGment:RESCale:YOFFset.....	872
MTESt:SEGment:STATe.....	867

MTESt:SOURce.....	864
MTESt:TOLerance.....	865
MTESt:WFMLupdate.....	873
MTESt:WFMRescale:XWIDth.....	873
MTESt:WFMRescale:YPOStion.....	874
MTESt:WFMRescale:YSTRetch.....	874
MTESt:WFMRescale:YWIDth.....	873
MTESt[:STATe].....	864
POWer:DESKew:CURRent.....	1091
POWer:DESKew:EXECute.....	1091
POWer:DESKew:RESet.....	1092
POWer:DESKew:TIME?.....	1092
POWer:DESKew:UDPReset.....	1092
POWer:DONRes:AUTO.....	1105
POWer:DONRes:AVG.....	1105
POWer:DONRes:EXECute.....	1105
POWer:DONRes:GATE<m>:STARt.....	1105
POWer:DONRes:GATE<m>:STOP.....	1105
POWer:DONRes:REPort:ADD.....	1105
POWer:DONRes:RESult:RESistance?.....	1105
POWer:EFFiciency:AUTO.....	1115
POWer:EFFiciency:EXECute.....	1116
POWer:EFFiciency:REPort:ADD.....	1116
POWer:EFFiciency:RESult<m>:ACTual?.....	1116
POWer:EFFiciency:RESult<m>:AVG?.....	1116
POWer:EFFiciency:RESult<m>:EVTCount?.....	1116
POWer:EFFiciency:RESult<m>:NPEak?.....	1116
POWer:EFFiciency:RESult<m>:PPEak?.....	1116
POWer:EFFiciency:RESult<m>:RMS?.....	1116
POWer:EFFiciency:RESult<m>:STDDev?.....	1116
POWer:EFFiciency:RESult<m>:WFMCOUNT?.....	1116
POWer:ENABle.....	1091
POWer:HARMonics:AUTO.....	1101
POWer:HARMonics:DOFR.....	1101
POWer:HARMonics:ENFR.....	1101
POWer:HARMonics:EVAL.....	1101
POWer:HARMonics:EXECute.....	1102
POWer:HARMonics:MIFR.....	1101
POWer:HARMonics:REPort:ADD.....	1102
POWer:HARMonics:RESult<m>:FREQuency<n>:VALue?.....	1102
POWer:HARMonics:RESult<m>:MAXValue<n>:VALue?.....	1102
POWer:HARMonics:RESult<m>:STDInuse?.....	1102
POWer:HARMonics:RESult<m>:STDValue<n>:VALue?.....	1102
POWer:HARMonics:RESult<m>:VALue<n>:VALue?.....	1102
POWer:HARMonics:STAN.....	1102
POWer:HARMonics:VOLT.....	1102
POWer:INRush:ADD.....	1099
POWer:INRush:COUNT?.....	1099
POWer:INRush:EXECute.....	1099
POWer:INRush:GATE<m>:STARt.....	1100

POWER:INRush:GATE<m>:STOP.....	1100
POWER:INRush:GATE<m>:VALue.....	1100
POWER:INRush:INSert.....	1099
POWER:INRush:MAXCurrent.....	1100
POWER:INRush:REMove.....	1099
POWER:INRush:REPort:ADD.....	1101
POWER:INRush:TRIGger.....	1100
POWER:MODulation:AUTO.....	1103
POWER:MODulation:DHIStoqram.....	1103
POWER:MODulation:EXECute.....	1103
POWER:MODulation:REPort:ADD.....	1103
POWER:MODulation:RESult:ACTual?.....	1104
POWER:MODulation:RESult:AVG?.....	1104
POWER:MODulation:RESult:EVTCount?.....	1104
POWER:MODulation:RESult:NPEak?.....	1104
POWER:MODulation:RESult:PPEak?.....	1104
POWER:MODulation:RESult:RMS?.....	1104
POWER:MODulation:RESult:STDDev?.....	1104
POWER:MODulation:RESult:WFMCCount?.....	1104
POWER:MODulation:SOURce.....	1104
POWER:MODulation:TYPE.....	1104
POWER:ONOf:ATOff.....	1110
POWER:ONOf:ATON.....	1110
POWER:ONOf:DSOff.....	1111
POWER:ONOf:DSOn.....	1111
POWER:ONOf:DTOff.....	1110
POWER:ONOf:DTON.....	1110
POWER:ONOf:EXECute.....	1111
POWER:ONOf:INPut.....	1111
POWER:ONOf:REPort:ADD.....	1111
POWER:ONOf:RESult:TOff?.....	1111
POWER:ONOf:RESult:TOnt?.....	1111
POWER:ONOf:STATe.....	1112
POWER:ONOf:TIME.....	1112
POWER:ONOf:TYPE.....	1112
POWER:QUALity:AUTO.....	1097
POWER:QUALity:EXECute.....	1098
POWER:QUALity:FREQ.....	1098
POWER:QUALity:REPort:ADD.....	1098
POWER:QUALity:RESult:CURRent:CREStfactor?.....	1098
POWER:QUALity:RESult:CURRent:FREQuency?.....	1098
POWER:QUALity:RESult:CURRent:PEAK?.....	1098
POWER:QUALity:RESult:CURRent:RMS?.....	1098
POWER:QUALity:RESult:POWer:APParent?.....	1098
POWER:QUALity:RESult:POWer:PFACTOR?.....	1098
POWER:QUALity:RESult:POWer:PHASe?.....	1098
POWER:QUALity:RESult:POWer:REACTive?.....	1098
POWER:QUALity:RESult:POWer:REALpower?.....	1098
POWER:QUALity:RESult:VOLTag:e:CREStfactor?.....	1098
POWER:QUALity:RESult:VOLTag:e:FREQuency?.....	1098

POWER:QUALity:RESult:VOLTage:PEAK?.....	1098
POWER:QUALity:RESult:VOLTage:RMS?.....	1098
POWER:REPort:CONTent:HSETup.....	1093
POWER:REPort:CONTent:MSETup.....	1093
POWER:REPort:CONTent:MSIGNAL.....	1093
POWER:REPort:CONTent:RESU.....	1093
POWER:REPort:CONTent:SETTings.....	1093
POWER:REPort:CONTent:TITLe.....	1093
POWER:REPort:CONTent:TSETup.....	1093
POWER:REPort:CONTent:VSETup.....	1093
POWER:REPort:DESCRiption.....	1093
POWER:REPort:DUT.....	1093
POWER:REPort:FILE:DELeTe.....	1094
POWER:REPort:FILE:NAME.....	1094
POWER:REPort:FILE:NEw.....	1094
POWER:REPort:FILE:SAVE.....	1094
POWER:REPort:FONT:COLO.....	1094
POWER:REPort:FONT:FAMI.....	1094
POWER:REPort:FONT:SIZE.....	1094
POWER:REPort:INVert.....	1095
POWER:REPort:LOGO.....	1094
POWER:REPort:PAPerSize.....	1094
POWER:REPort:SITe.....	1093
POWER:REPort:TEMPerature.....	1093
POWER:REPort:TEST:ADD.....	1094
POWER:REPort:TEST:COMMeNt.....	1096
POWER:REPort:TEST:COUNt.....	1097
POWER:REPort:TEST:DIRectory.....	1096
POWER:REPort:TEST:DSEA.....	1095
POWER:REPort:TEST:INSert.....	1094
POWER:REPort:TEST:ISE.....	1095
POWER:REPort:TEST:LSEnd?.....	1097
POWER:REPort:TEST:REMOve.....	1094
POWER:REPort:TEST:RSE.....	1095
POWER:REPort:TEST:SEA.....	1095
POWER:REPort:USER.....	1093
POWER:RIPPlE:AUToscale.....	1117
POWER:RIPPlE:CURRent.....	1117
POWER:RIPPlE:EXECute.....	1117
POWER:RIPPlE:FREQuency.....	1117
POWER:RIPPlE:REPort:ADD.....	1117
POWER:RIPPlE:RESult:FREQuency?.....	1117
POWER:RIPPlE:RESult:MAXimum?.....	1117
POWER:RIPPlE:RESult:MINimum?.....	1117
POWER:RIPPlE:RESult:NDCYcle?.....	1117
POWER:RIPPlE:RESult:PDCYcle?.....	1118
POWER:RIPPlE:RESult:PDEL?.....	1118
POWER:RIPPlE:RESult:PERiod?.....	1118
POWER:RIPPlE:RESult:STDDev?.....	1118
POWER:SLEWrate:AUTO.....	1106

POWER:SLEWrate:AVGDeriv.....	1106
POWER:SLEWrate:EXECute.....	1106
POWER:SLEWrate:GATE:START.....	1107
POWER:SLEWrate:GATE:STOP.....	1107
POWER:SLEWrate:REPort:ADD.....	1107
POWER:SLEWrate:RESult:ACTual?.....	1107
POWER:SLEWrate:RESult:AVG?.....	1107
POWER:SLEWrate:RESult:EVTCount?.....	1107
POWER:SLEWrate:RESult:NPEak?.....	1107
POWER:SLEWrate:RESult:PPEak?.....	1107
POWER:SLEWrate:RESult:RMS?.....	1107
POWER:SLEWrate:RESult:STDDev?.....	1107
POWER:SLEWrate:RESult:WFMCount?.....	1107
POWER:SLEWrate:SOURce.....	1107
POWER:SOA:EXECute.....	1108
POWER:SOA:LINear:ADD.....	1108
POWER:SOA:LINear:COUNt?.....	1108
POWER:SOA:LINear:INSert.....	1109
POWER:SOA:LINear:POINt<m>:CURRent.....	1109
POWER:SOA:LINear:POINt<m>:VOLTagE.....	1109
POWER:SOA:LINear:REMove.....	1108
POWER:SOA:LOGarithmic:ADD.....	1108
POWER:SOA:LOGarithmic:COUNt?.....	1108
POWER:SOA:LOGarithmic:INSert.....	1109
POWER:SOA:LOGarithmic:POINt<m>:CURRent.....	1109
POWER:SOA:LOGarithmic:POINt<m>:VOLTagE.....	1109
POWER:SOA:LOGarithmic:REMove.....	1108
POWER:SOA:MASK.....	1109
POWER:SOA:REPort:ADD.....	1109
POWER:SOA:SCALE.....	1110
POWER:SOA:SWITCh.....	1110
POWER:SOURce:CURRent<1..2>.....	1091
POWER:SOURce:VOLTagE<1..4>.....	1091
POWER:SPECtrum:AUToscale.....	1121
POWER:SPECtrum:EXECute.....	1121
POWER:SPECtrum:FREQuency.....	1121
POWER:SPECtrum:REPort:ADD.....	1121
POWER:SPECtrum:RESult<m>:FREQuency?.....	1121
POWER:SPECtrum:RESult<m>:LEVel?.....	1122
POWER:SWITChing:AUTO.....	1113
POWER:SWITChing:COND.....	1114
POWER:SWITChing:EXECute.....	1113
POWER:SWITChing:GATE:COND:START.....	1114
POWER:SWITChing:GATE:COND:STOP.....	1114
POWER:SWITChing:GATE:NCON:START.....	1114
POWER:SWITChing:GATE:NCON:STOP.....	1114
POWER:SWITChing:GATE:TOFF:START.....	1114
POWER:SWITChing:GATE:TOFF:STOP.....	1114
POWER:SWITChing:GATE:TON:START.....	1114
POWER:SWITChing:GATE:TON:STOP.....	1114

POWER:SWITChing:NCON.....	1114
POWER:SWITChing:REPort:ADD.....	1113
POWER:SWITChing:RESult:ENERgy:ACTual?.....	1114
POWER:SWITChing:RESult:ENERgy:AVG?.....	1114
POWER:SWITChing:RESult:ENERgy:EVTCount?.....	1114
POWER:SWITChing:RESult:ENERgy:NPEak?.....	1114
POWER:SWITChing:RESult:ENERgy:PPEak?.....	1114
POWER:SWITChing:RESult:ENERgy:RMS?.....	1114
POWER:SWITChing:RESult:ENERgy:STDDev?.....	1114
POWER:SWITChing:RESult:ENERgy:WFMCCount?.....	1114
POWER:SWITChing:RESult:POWer:ACTual?.....	1115
POWER:SWITChing:RESult:POWer:AVG?.....	1115
POWER:SWITChing:RESult:POWer:EVTCount?.....	1115
POWER:SWITChing:RESult:POWer:NPEak?.....	1115
POWER:SWITChing:RESult:POWer:PPEak?.....	1115
POWER:SWITChing:RESult:POWer:RMS?.....	1115
POWER:SWITChing:RESult:POWer:STDDev?.....	1115
POWER:SWITChing:RESult:POWer:WFMCCount?.....	1115
POWER:SWITChing:SWIFrequency.....	1113
POWER:SWITChing:SWIT.....	1113
POWER:SWITChing:TOFF.....	1114
POWER:SWITChing:TON.....	1114
POWER:SWITChing:TOTal.....	1114
POWER:TRANSient:AUToscale.....	1118
POWER:TRANSient:EXECute.....	1119
POWER:TRANSient:FREQuency.....	1119
POWER:TRANSient:HYSteresis.....	1119
POWER:TRANSient:INPut.....	1119
POWER:TRANSient:REPort:ADD.....	1119
POWER:TRANSient:RESult[:ACTual]?.....	1119
POWER:TRANSient:SIGHigh.....	1120
POWER:TRANSient:SIGLow.....	1120
POWER:TRANSient:TRGChannel.....	1120
POWER:TRANSient:TRGLevel.....	1120
POWER:TRANSient:TRGSlope.....	1120
PROBE<m>:ID:PARTnumber?.....	698
PROBE<m>:ID:PRDate?.....	698
PROBE<m>:ID:SRNumber?.....	699
PROBE<m>:ID:SWVersion?.....	698
PROBE<m>:SETup:ATTenuation:DEFProbe.....	692
PROBE<m>:SETup:ATTenuation:MANual.....	693
PROBE<m>:SETup:ATTenuation:MODE.....	691
PROBE<m>:SETup:ATTenuation:UNIT.....	692
PROBE<m>:SETup:ATTenuation[:AUTO]?.....	691
PROBE<m>:SETup:BANDwidth?.....	697
PROBE<m>:SETup:CAPacitance?.....	697
PROBE<m>:SETup:CMOffset.....	695
PROBE<m>:SETup:DISPlaydiff.....	698
PROBE<m>:SETup:GAIN:AUTO?.....	693
PROBE<m>:SETup:GAIN:MANual.....	693

PROBe<m>:SETup:IMPedance?	697
PROBe<m>:SETup:MODE	695
PROBe<m>:SETup:NAME?	696
PROBe<m>:SETup:OFFSet:AZERo	694
PROBe<m>:SETup:OFFSet:TOMean	695
PROBe<m>:SETup:STATe?	691
PROBe<m>:SETup:TYPE?	696
PROBe<m>:SETup:ZA15	694
REFCurve<m>:CLEAr	777
REFCurve<m>:DATA:HEADer?	781
REFCurve<m>:DATA:STYPe?	781
REFCurve<m>:DATA[:VALues]?	782
REFCurve<m>:DELete	777
REFCurve<m>:HMODE	779
REFCurve<m>:NAME	776
REFCurve<m>:OPEN	776
REFCurve<m>:POSition	778
REFCurve<m>:RESCale:HORizontal:FACTor	780
REFCurve<m>:RESCale:HORizontal:OFFSet	780
REFCurve<m>:RESCale:HORizontal:STATe	780
REFCurve<m>:RESCale:VERTical:FACTor	779
REFCurve<m>:RESCale:VERTical:OFFSet	779
REFCurve<m>:RESCale:VERTical:STATe	778
REFCurve<m>:RESTore	777
REFCurve<m>:SAVE	776
REFCurve<m>:SCALE	778
REFCurve<m>:SOURce	775
REFCurve<m>:STATe	775
REFCurve<m>:UPDate	776
REFCurve<m>:VMODE	777
REFLevel<m>:ABSolute:BDIStance	803
REFLevel<m>:ABSolute:BITube	808
REFLevel<m>:ABSolute:BOTube	808
REFLevel<m>:ABSolute:HIGH	801
REFLevel<m>:ABSolute:LLEVel	804
REFLevel<m>:ABSolute:LOW	802
REFLevel<m>:ABSolute:MLEVel	804
REFLevel<m>:ABSolute:TDIStance	802
REFLevel<m>:ABSolute:TITube	808
REFLevel<m>:ABSolute:TOTube	807
REFLevel<m>:ABSolute:ULEVel	803
REFLevel<m>:AUTO:COUNT	801
REFLevel<m>:AUTO:MODE	799
REFLevel<m>:AUTO[:STATe]	800
REFLevel<m>:LDETection	797
REFLevel<m>:LMODE	799
REFLevel<m>:RELative:HYSTeresis	806
REFLevel<m>:RELative:ITUBE	807
REFLevel<m>:RELative:LOWer	806
REFLevel<m>:RELative:MIDDLE	805

REFLevel<m>:RELative:MODE.....	797
REFLevel<m>:RELative:OTUBe.....	807
REFLevel<m>:RELative:UPPer.....	805
REFLevel<m>:USRLevel.....	798
RUN.....	676
RUNContinous.....	676
RUNSingle.....	676
SEARch:ADD.....	878
SEARch:ALL.....	879
SEARch:CLear.....	878
SEARch:GATE:ABSolute:STARt.....	904
SEARch:GATE:ABSolute:STOP.....	904
SEARch:GATE:MODE.....	904
SEARch:GATE:RELative:STARt.....	905
SEARch:GATE:RELative:STOP.....	905
SEARch:GATE:SHOW.....	904
SEARch:GATE:ZCOupling.....	905
SEARch:GATE:ZDIagram.....	905
SEARch:GATE[:STATe].....	903
SEARch:ONLine.....	879
SEARch:REMOve.....	879
SEARch:RESDiagram:HORIZ:ABSolute:POSition.....	908
SEARch:RESDiagram:HORIZ:ABSolute:SPAN.....	908
SEARch:RESDiagram:HORIZ:MODE.....	908
SEARch:RESDiagram:HORIZ:RELative:POSition.....	909
SEARch:RESDiagram:HORIZ:RELative:SPAN.....	909
SEARch:RESDiagram:SHOW.....	909
SEARch:RESDiagram:VERT:ABSolute:POSition.....	909
SEARch:RESDiagram:VERT:ABSolute:SPAN.....	910
SEARch:RESDiagram:VERT:MODE.....	910
SEARch:RESDiagram:VERT:RELative:POSition.....	910
SEARch:RESDiagram:VERT:RELative:SPAN.....	910
SEARch:RESult:LIMit.....	911
SEARch:RESult:SHOW.....	911
SEARch:RESult:SORT:ASCending.....	911
SEARch:RESult:SORT[:MODE].....	912
SEARch:RESult[:ALL]?.....	912
SEARch:SOURce.....	879
SEARch:TRIGger:DAtatoclock:ACOPY.....	881
SEARch:TRIGger:DAtatoclock:CEdGe.....	894
SEARch:TRIGger:DAtatoclock:CLEVel.....	895
SEARch:TRIGger:DAtatoclock:CSOURce.....	895
SEARch:TRIGger:DAtatoclock:HTIME.....	895
SEARch:TRIGger:DAtatoclock:STIME.....	896
SEARch:TRIGger:DAtatoclock[:STATe].....	880
SEARch:TRIGger:EDGE:ACOPY.....	881
SEARch:TRIGger:EDGE:BCOPY.....	882
SEARch:TRIGger:EDGE:SLOPe.....	882
SEARch:TRIGger:EDGE[:STATe].....	880
SEARch:TRIGger:GLITCh:ACOPY.....	881

SEARch:TRIGger:GLITch:POLarity.....	882
SEARch:TRIGger:GLITch:RANGe.....	883
SEARch:TRIGger:GLITch:WIDTh.....	883
SEARch:TRIGger:GLITch[:STATe].....	880
SEARch:TRIGger:INTerval:ACOPy.....	881
SEARch:TRIGger:INTerval:DELTA.....	883
SEARch:TRIGger:INTerval:POLarity.....	884
SEARch:TRIGger:INTerval:RANGe.....	884
SEARch:TRIGger:INTerval:WIDTh.....	884
SEARch:TRIGger:INTerval[:STATe].....	880
SEARch:TRIGger:LEVel:NOISe:ABSolute.....	906
SEARch:TRIGger:LEVel:NOISe:MODE.....	906
SEARch:TRIGger:LEVel:NOISe:RELative.....	907
SEARch:TRIGger:LEVel:NOISe[:STATe].....	907
SEARch:TRIGger:LEVel:RUNT:LOWer.....	887
SEARch:TRIGger:LEVel:RUNT:UPPer.....	887
SEARch:TRIGger:LEVel:TRANSition:LOWer.....	889
SEARch:TRIGger:LEVel:TRANSition:UPPer.....	889
SEARch:TRIGger:LEVel:WINDow:LOWer.....	894
SEARch:TRIGger:LEVel:WINDow:UPPer.....	894
SEARch:TRIGger:LEVel[:VALue].....	881
SEARch:TRIGger:PATTern:A:LOGic.....	897
SEARch:TRIGger:PATTern:A[:ENABle].....	896
SEARch:TRIGger:PATTern:AB:LOGic.....	898
SEARch:TRIGger:PATTern:ABCD:LOGic.....	898
SEARch:TRIGger:PATTern:ACOPy.....	881
SEARch:TRIGger:PATTern:B:LOGic.....	897
SEARch:TRIGger:PATTern:B[:ENABle].....	896
SEARch:TRIGger:PATTern:C:LOGic.....	897
SEARch:TRIGger:PATTern:C[:ENABle].....	896
SEARch:TRIGger:PATTern:CD:LOGic.....	898
SEARch:TRIGger:PATTern:D:LOGic.....	897
SEARch:TRIGger:PATTern:D[:ENABle].....	896
SEARch:TRIGger:PATTern:MODE.....	898
SEARch:TRIGger:PATTern:TImeout:MODE.....	899
SEARch:TRIGger:PATTern:TImeout[:TImE].....	899
SEARch:TRIGger:PATTern:WIDTh:DELTA.....	900
SEARch:TRIGger:PATTern:WIDTh:RANGe.....	899
SEARch:TRIGger:PATTern:WIDTh[:WIDTh].....	900
SEARch:TRIGger:PATTern[:STATe].....	880
SEARch:TRIGger:RUNT:ACOPy.....	881
SEARch:TRIGger:RUNT:DELTA.....	885
SEARch:TRIGger:RUNT:POLarity.....	885
SEARch:TRIGger:RUNT:RANGe.....	886
SEARch:TRIGger:RUNT:WIDTh.....	886
SEARch:TRIGger:RUNT[:STATe].....	880
SEARch:TRIGger:SLEWrate:ACOPy.....	881
SEARch:TRIGger:SLEWrate:DELTA.....	887
SEARch:TRIGger:SLEWrate:RANGe.....	887
SEARch:TRIGger:SLEWrate:SLOPe.....	888

SEARch:TRIGger:SLEWrate:TIME.....	888
SEARch:TRIGger:SLEWrate[:STATe].....	880
SEARch:TRIGger:STATe:A:LOGic.....	902
SEARch:TRIGger:STATe:A[:ENABle].....	902
SEARch:TRIGger:STATe:AB:LOGic.....	903
SEARch:TRIGger:STATe:ABCD:LOGic.....	903
SEARch:TRIGger:STATe:ACOPy.....	881
SEARch:TRIGger:STATe:B:LOGic.....	902
SEARch:TRIGger:STATe:B[:ENABle].....	902
SEARch:TRIGger:STATe:C:LOGic.....	902
SEARch:TRIGger:STATe:C[:ENABle].....	902
SEARch:TRIGger:STATe:CD:LOGic.....	903
SEARch:TRIGger:STATe:CEdGe.....	901
SEARch:TRIGger:STATe:CLEVel.....	901
SEARch:TRIGger:STATe:CSourCe.....	901
SEARch:TRIGger:STATe:D:LOGic.....	902
SEARch:TRIGger:STATe:D[:ENABle].....	902
SEARch:TRIGger:STATe[:STATe].....	880
SEARch:TRIGger:TIMEout:ACOPy.....	881
SEARch:TRIGger:TIMEout:RANGe.....	889
SEARch:TRIGger:TIMEout:TIME.....	890
SEARch:TRIGger:TIMEout[:STATe].....	880
SEARch:TRIGger:WIDTh:ACOPy.....	881
SEARch:TRIGger:WIDTh:DELTA.....	890
SEARch:TRIGger:WIDTh:POLarity.....	890
SEARch:TRIGger:WIDTh:RANGe.....	891
SEARch:TRIGger:WIDTh:WIDTh.....	891
SEARch:TRIGger:WIDTh[:STATe].....	881
SEARch:TRIGger:WINDow:ACOPy.....	881
SEARch:TRIGger:WINDow:DELTA.....	892
SEARch:TRIGger:WINDow:RANGe.....	892
SEARch:TRIGger:WINDow:TIMERange.....	893
SEARch:TRIGger:WINDow:WIDTh.....	893
SEARch:TRIGger:WINDow[:STATe].....	881
SENSe[:ROSCillator]:EXTErnal:FREQuency.....	701
SENSe[:ROSCillator]:SOURCe.....	701
SINGle.....	676
STATus:OPERation:CONDition?.....	1123
STATus:OPERation[:EVENT]?.....	1123
STATus:QUEStionable:COVerload:CONDition?.....	1125
STATus:QUEStionable:COVerload:ENABle.....	1125
STATus:QUEStionable:COVerload:NTRansition.....	1126
STATus:QUEStionable:COVerload:PTRansition.....	1126
STATus:QUEStionable:COVerload[:EVENT]?.....	1126
STATus:QUEStionable:LIMit:CONDition?.....	1125
STATus:QUEStionable:LIMit:ENABle.....	1125
STATus:QUEStionable:LIMit:NTRansition.....	1126
STATus:QUEStionable:LIMit:PTRansition.....	1126
STATus:QUEStionable:LIMit[:EVENT]?.....	1126
STATus:QUEStionable:MARGin:CONDition?.....	1125

STATus:QUEStionable:MARGin:ENABle.....	1125
STATus:QUEStionable:MARGin:NTRansition.....	1126
STATus:QUEStionable:MARGin:PTRansition.....	1126
STATus:QUEStionable:MARGin[:EVENT]?.....	1126
STATus:QUEStionable:MASK:CONDition?.....	1125
STATus:QUEStionable:MASK:ENABle.....	1125
STATus:QUEStionable:MASK:NTRansition.....	1126
STATus:QUEStionable:MASK:PTRansition.....	1126
STATus:QUEStionable:MASK[:EVENT]?.....	1126
STATus:QUEStionable:TEMPerature:CONDition?.....	1125
STATus:QUEStionable:TEMPerature:ENABle.....	1125
STATus:QUEStionable:TEMPerature:NTRansition.....	1126
STATus:QUEStionable:TEMPerature:PTRansition.....	1126
STATus:QUEStionable:TEMPerature[:EVENT]?.....	1126
STOP.....	676
SYSTem:COMMunicate:PRINter:ENUMerate:FIRSt?.....	933
SYSTem:COMMunicate:PRINter:ENUMerate[:NEXT]?.....	933
SYSTem:COMMunicate:PRINter:SELect<1..2>.....	933
SYSTem:DATE.....	934
SYSTem:DEVice:ID?.....	935
SYSTem:DFPRint.....	936
SYSTem:DISPlay:UPDate.....	675
SYSTem:ERRor:ALL?.....	936
SYSTem:ERRor:CODE:ALL?.....	937
SYSTem:ERRor:CODE[:NEXT]?.....	937
SYSTem:ERRor:COUNT?.....	938
SYSTem:ERRor[:NEXT]?.....	937
SYSTem:EXIT.....	934
SYSTem:KLOCK.....	675
SYSTem:LANGuage.....	675
SYSTem:PRESet.....	934
SYSTem:RESet.....	934
SYSTem:TIME?.....	935
SYSTem:VERSion?.....	936
TIMebase:DIVisions?.....	677
TIMebase:HORIZontal:POSition.....	677
TIMebase:HORIZontal:POSition.....	744
TIMebase:RACTime?.....	855
TIMebase:RANGe.....	677
TIMebase:REFerence.....	678
TIMebase:REFerence.....	744
TIMebase:ROLL:ENABle.....	678
TIMebase:ROLL:MTIME.....	678
TIMebase:SCALE.....	677
TIMebase[:TRIGger]:POSition.....	745
TRIGger<m>:ANEDge:COUPling.....	707
TRIGger<m>:ANEDge:CUToff:HIGHPass.....	707
TRIGger<m>:ANEDge:CUToff:LOWPass.....	707
TRIGger<m>:ANEDge:FILTer.....	708
TRIGger<m>:ANEDge:GND.....	708

TRIGger<m>:ANEDge:SLOPe.....	709
TRIGger<m>:CAN:ACKerror.....	988
TRIGger<m>:CAN:BITSterror.....	988
TRIGger<m>:CAN:BORDER.....	987
TRIGger<m>:CAN:CRCError.....	989
TRIGger<m>:CAN:DcONdition.....	986
TRIGger<m>:CAN:DLC.....	988
TRIGger<m>:CAN:DLCCONdition.....	987
TRIGger<m>:CAN:DMAX.....	987
TRIGger<m>:CAN:DMIN.....	986
TRIGger<m>:CAN:FORMError.....	989
TRIGger<m>:CAN:FTYPe.....	984
TRIGger<m>:CAN:ICONdition.....	985
TRIGger<m>:CAN:IMAX.....	986
TRIGger<m>:CAN:IMIN.....	986
TRIGger<m>:CAN:ITYPe.....	985
TRIGger<m>:CAN:TYPE.....	983
TRIGger<m>:COUPling.....	700
TRIGger<m>:DATatoclock:CSourCe:EDGE.....	722
TRIGger<m>:DATatoclock:CSourCe:LEVel.....	722
TRIGger<m>:DATatoclock:CSourCe[:VALue].....	722
TRIGger<m>:DATatoclock:HTIME.....	723
TRIGger<m>:DATatoclock:STIME.....	723
TRIGger<m>:ECOupling.....	706
TRIGger<m>:EDGE:SLOPe.....	706
TRIGger<m>:FINDlevel.....	705
TRIGger<m>:FLXRay:BSSerror.....	1025
TRIGger<m>:FLXRay:CENable.....	1022
TRIGger<m>:FLXRay:CMAx.....	1022
TRIGger<m>:FLXRay:CMIN.....	1022
TRIGger<m>:FLXRay:CSTep.....	1023
TRIGger<m>:FLXRay:DcONdition.....	1024
TRIGger<m>:FLXRay:DMAx.....	1025
TRIGger<m>:FLXRay:DMIN.....	1025
TRIGger<m>:FLXRay:DPOperator.....	1023
TRIGger<m>:FLXRay:DPOsition.....	1024
TRIGger<m>:FLXRay:DPTO.....	1024
TRIGger<m>:FLXRay:FcONdition.....	1020
TRIGger<m>:FLXRay:FESerror.....	1026
TRIGger<m>:FLXRay:FMAx.....	1020
TRIGger<m>:FLXRay:FMIN.....	1020
TRIGger<m>:FLXRay:FSSerror.....	1026
TRIGger<m>:FLXRay:HCRCError.....	1026
TRIGger<m>:FLXRay:NUFRame.....	1019
TRIGger<m>:FLXRay:PcONdition.....	1021
TRIGger<m>:FLXRay:PCRCError.....	1026
TRIGger<m>:FLXRay:PLPReamble.....	1018
TRIGger<m>:FLXRay:PMAx.....	1021
TRIGger<m>:FLXRay:PMIN.....	1021
TRIGger<m>:FLXRay:STFRame.....	1019

TRIGger<m>:FLXRay:SYFRame.....	1019
TRIGger<m>:FLXRay:SYMBOL.....	1025
TRIGger<m>:FLXRay:TYPE.....	1017
TRIGger<m>:FORCE.....	746
TRIGger<m>:GLITch:POLarity.....	709
TRIGger<m>:GLITch:RANGe.....	709
TRIGger<m>:GLITch:WIDTh.....	710
TRIGger<m>:HOLDoff:AUTotime?.....	743
TRIGger<m>:HOLDoff:EVENTs.....	742
TRIGger<m>:HOLDoff:MAX.....	743
TRIGger<m>:HOLDoff:MIN.....	742
TRIGger<m>:HOLDoff:MODE.....	741
TRIGger<m>:HOLDoff:SCALing.....	744
TRIGger<m>:HOLDoff:TIME.....	741
TRIGger<m>:I2C:ACCess.....	943
TRIGger<m>:I2C:ACONdition.....	945
TRIGger<m>:I2C:ADDResS.....	945
TRIGger<m>:I2C:ADDTo.....	946
TRIGger<m>:I2C:ADNack.....	944
TRIGger<m>:I2C:ADOR<n>:ADRTyPe.....	946
TRIGger<m>:I2C:ADOR<n>:ENABle.....	946
TRIGger<m>:I2C:ADOR<n>:RWBit.....	947
TRIGger<m>:I2C:ADOR<n>[:VALue].....	947
TRIGger<m>:I2C:AMODe.....	945
TRIGger<m>:I2C:DCONdition.....	948
TRIGger<m>:I2C:DMAX.....	949
TRIGger<m>:I2C:DMIN.....	949
TRIGger<m>:I2C:DPOPerator.....	947
TRIGger<m>:I2C:DPOStion.....	948
TRIGger<m>:I2C:DPTO.....	948
TRIGger<m>:I2C:DRNack.....	944
TRIGger<m>:I2C:DWNack.....	944
TRIGger<m>:I2C:MODE.....	943
TRIGger<m>:I2S:SOWords.....	1043
TRIGger<m>:I2S:TCONdition<n>:CHANnel.....	1040
TRIGger<m>:I2S:TCONdition<n>:CONDtion.....	1041
TRIGger<m>:I2S:TCONdition<n>:DMAX.....	1042
TRIGger<m>:I2S:TCONdition<n>:DMIN.....	1042
TRIGger<m>:I2S:TYPE.....	1039
TRIGger<m>:I2S:WSSLope.....	1043
TRIGger<m>:INTerval:DELTA.....	719
TRIGger<m>:INTerval:POLarity.....	718
TRIGger<m>:INTerval:RANGe.....	718
TRIGger<m>:INTerval:WIDTh.....	718
TRIGger<m>:LEVel<n>:NOISe:ABSolute.....	737
TRIGger<m>:LEVel<n>:NOISe:MODE.....	737
TRIGger<m>:LEVel<n>:NOISe:RELative.....	738
TRIGger<m>:LEVel<n>:NOISe[:STATe].....	736
TRIGger<m>:LEVel<n>:RUNT:LOWer.....	712
TRIGger<m>:LEVel<n>:RUNT:UPPer.....	712

TRIGger<m>:LEVel<n>:SLEW:LOWer.....	720
TRIGger<m>:LEVel<n>:SLEW:UPPer.....	719
TRIGger<m>:LEVel<n>:WINDow:LOWer.....	715
TRIGger<m>:LEVel<n>:WINDow:UPPer.....	714
TRIGger<m>:LEVel<n>[:VALue].....	704
TRIGger<m>:LEVel<n>[:VALue].....	1085
TRIGger<m>:LEVel<n>[:VALue].....	1086
TRIGger<m>:LIN:BORDer.....	1001
TRIGger<m>:LIN:CHKSError.....	1004
TRIGger<m>:LIN:CRCDatalen.....	1005
TRIGger<m>:LIN:DCONDition.....	1000
TRIGger<m>:LIN:DLECondition.....	1002
TRIGger<m>:LIN:DLEngth.....	1002
TRIGger<m>:LIN:DMAX.....	1001
TRIGger<m>:LIN:DMIN.....	1001
TRIGger<m>:LIN:ERRPattern.....	1004
TRIGger<m>:LIN:ICONDition.....	999
TRIGger<m>:LIN:IDOR<n>:ENABle.....	1003
TRIGger<m>:LIN:IDOR<n>[:VALue].....	1003
TRIGger<m>:LIN:IMAX.....	1000
TRIGger<m>:LIN:IMIN.....	1000
TRIGger<m>:LIN:IPERror.....	1004
TRIGger<m>:LIN:STANdard.....	1005
TRIGger<m>:LIN:SYERror.....	1003
TRIGger<m>:LIN:TYPE.....	998
TRIGger<m>:MODE.....	745
TRIGger<m>:NFC:BITRate.....	1074
TRIGger<m>:NFC:EVENT.....	1074
TRIGger<m>:NFC:TECHnology.....	1074
TRIGger<m>:OFFSet:LIMited.....	745
TRIGger<m>:OUT:DELay.....	747
TRIGger<m>:OUT:PLEngth.....	747
TRIGger<m>:OUT:POLarity.....	746
TRIGger<m>:OUT:STATe.....	746
TRIGger<m>:PARAllel:DATatoclock:CSourCe:EDGE.....	1063
TRIGger<m>:PARAllel:DATatoclock:CSourCe[:VALue].....	1059
TRIGger<m>:PARAllel:DATatoclock:HTIME.....	1064
TRIGger<m>:PARAllel:DATatoclock:STIME.....	1064
TRIGger<m>:PARAllel:EDGE:EXPRession[:DEFine].....	1060
TRIGger<m>:PARAllel:EDGE:SLOPe.....	1060
TRIGger<m>:PARAllel:PATTern:BIT<n>.....	1065
TRIGger<m>:PARAllel:PATTern:EXPRession[:DEFine].....	1060
TRIGger<m>:PARAllel:PATTern:MODE.....	1065
TRIGger<m>:PARAllel:PATTern:TIMEout:MODE.....	1066
TRIGger<m>:PARAllel:PATTern:TIMEout[:TIME].....	1066
TRIGger<m>:PARAllel:PATTern:WIDTh:DELTA.....	1068
TRIGger<m>:PARAllel:PATTern:WIDTh:RANGe.....	1067
TRIGger<m>:PARAllel:PATTern:WIDTh[:WIDTh].....	1067
TRIGger<m>:PARAllel:SPATTern:CSourCe:EDGE.....	1068
TRIGger<m>:PARAllel:SPATTern:CSourCe[:VALue].....	1059

TRIGger<m>:PARAllel:SPATtern:EXPRession[:DEFine].....	1060
TRIGger<m>:PARAllel:SPATtern:PATtern.....	1068
TRIGger<m>:PARAllel:STATe:BIT<n>.....	1065
TRIGger<m>:PARAllel:STATe:CSourCe:EDGE.....	1064
TRIGger<m>:PARAllel:STATe:CSourCe:VALue.....	1059
TRIGger<m>:PARAllel:STATe:EXPRession[:DEFine].....	1060
TRIGger<m>:PARAllel:TIMeout:EXPRession[:DEFine].....	1060
TRIGger<m>:PARAllel:TIMeout:RANGe.....	1062
TRIGger<m>:PARAllel:TIMeout:TIME.....	1063
TRIGger<m>:PARAllel:TYPE.....	1059
TRIGger<m>:PARAllel:WIDTh:DELTA.....	1062
TRIGger<m>:PARAllel:WIDTh:EXPRession[:DEFine].....	1060
TRIGger<m>:PARAllel:WIDTh:POLarity.....	1061
TRIGger<m>:PARAllel:WIDTh:RANGe.....	1061
TRIGger<m>:PARAllel:WIDTh:WIDTh.....	1061
TRIGger<m>:PATtern:MODE.....	724
TRIGger<m>:PATtern:TIMeout:MODE.....	725
TRIGger<m>:PATtern:TIMeout[:TIME].....	725
TRIGger<m>:PATtern:WIDTh:DELTA.....	726
TRIGger<m>:PATtern:WIDTh:RANGe.....	726
TRIGger<m>:PATtern:WIDTh[:WIDTh].....	726
TRIGger<m>:QUALify<n>:A:LOGic.....	735
TRIGger<m>:QUALify<n>:A[:ENABLE].....	734
TRIGger<m>:QUALify<n>:AB:LOGic.....	736
TRIGger<m>:QUALify<n>:ABCD:LOGic.....	736
TRIGger<m>:QUALify<n>:B:LOGic.....	735
TRIGger<m>:QUALify<n>:B[:ENABLE].....	734
TRIGger<m>:QUALify<n>:C:LOGic.....	735
TRIGger<m>:QUALify<n>:C[:ENABLE].....	735
TRIGger<m>:QUALify<n>:CD:LOGic.....	736
TRIGger<m>:QUALify<n>:D:LOGic.....	735
TRIGger<m>:QUALify<n>:D[:ENABLE].....	735
TRIGger<m>:QUALify<n>:STATe.....	734
TRIGger<m>:RFReject<n>.....	700
TRIGger<m>:ROBust.....	705
TRIGger<m>:RUNT:DELTA.....	714
TRIGger<m>:RUNT:POLarity.....	712
TRIGger<m>:RUNT:RANGe.....	713
TRIGger<m>:RUNT:WIDTh.....	713
TRIGger<m>:SCOupling.....	706
TRIGger<m>:SEQuence:COUNt.....	739
TRIGger<m>:SEQuence:DELay.....	739
TRIGger<m>:SEQuence:MODE.....	739
TRIGger<m>:SEQuence:RESet:EVENT.....	740
TRIGger<m>:SEQuence:RESet:TIMeout:TIME.....	740
TRIGger<m>:SEQuence:RESet:TIMeout[:ENABLE].....	740
TRIGger<m>:SLEW:DELTA.....	721
TRIGger<m>:SLEW:RANGe.....	720
TRIGger<m>:SLEW:RATE.....	721
TRIGger<m>:SLEW:SLOPe.....	719

TRIGger<m>:SOURce.....	702
TRIGger<m>:SOURce.....	1058
TRIGger<m>:SPATtern:CSOURce:EDGE.....	727
TRIGger<m>:SPATtern:CSOURce:LEVel.....	727
TRIGger<m>:SPATtern:CSOURce[VALue].....	727
TRIGger<m>:SPATtern:PATTern.....	728
TRIGger<m>:SPI:DPOPerator.....	964
TRIGger<m>:SPI:DPOStition.....	965
TRIGger<m>:SPI:DPTO.....	965
TRIGger<m>:SPI:FCONdition.....	965
TRIGger<m>:SPI:MISopattern.....	966
TRIGger<m>:SPI:MODE.....	963
TRIGger<m>:SPI:MOSipattern.....	966
TRIGger<m>:SPI:PALignment.....	964
TRIGger<m>:TIMEout:RANGe.....	717
TRIGger<m>:TIMEout:TIME.....	717
TRIGger<m>:TV:CUSTom:LDURation.....	732
TRIGger<m>:TV:CUSTom:SCANmode.....	732
TRIGger<m>:TV:CUSTom:SDURation.....	733
TRIGger<m>:TV:CUSTom:STYPe.....	732
TRIGger<m>:TV:LField.....	731
TRIGger<m>:TV:LINE.....	730
TRIGger<m>:TV:MODE.....	729
TRIGger<m>:TV:POLarity.....	730
TRIGger<m>:TV:STANdard.....	728
TRIGger<m>:TYPE.....	703
TRIGger<m>:UART:DATA.....	977
TRIGger<m>:UART:DPOPerator.....	976
TRIGger<m>:UART:DPOStition.....	976
TRIGger<m>:UART:DPTO.....	977
TRIGger<m>:UART:FCONdition.....	977
TRIGger<m>:UART:SOURce.....	976
TRIGger<m>:UART:TYPE.....	975
TRIGger<m>:WIDTh:DELTA.....	711
TRIGger<m>:WIDTh:POLarity.....	710
TRIGger<m>:WIDTh:RANGe.....	711
TRIGger<m>:WIDTh:WIDTh.....	711
TRIGger<m>:WINDow:DELTA.....	716
TRIGger<m>:WINDow:RANGe.....	715
TRIGger<m>:WINDow:TIME.....	715
TRIGger<m>:WINDow:WIDTh.....	716
WAVeform<m>:XYCurve:RATio.....	769
WAVeform<m>:XYCurve:STATe.....	769
WAVeform<m>:XYCurve:SWAP.....	770
WAVeform<m>:XYCurve:XSource.....	770
WAVeform<m>:XYCurve:YSource.....	770

Index

Symbols

*OPC	649
*OPC?	649
*RST	663
*WAI	649

A

AC Coupling	
Trying out	47
Acq. completed, mask test result	317
Acq. remaining, mask test result	317
Acquisition	
Decimation	111
Enhancement	110
modes	94
Resolution	108
Settings	110
Single, multiple	31
Start	31
Stop	31
Time	96
Trying out	42
Ultra Segmentation	113
Acquisition hits, mask test result	317
ACQUISITION key	30
Acquisition modes	94, 110
Acquisition time	96
Actions	
Mask test	334
Active probe	
differential	100
Micro button	125
overview	99
ProbeMeter	124
Setup	122
Active waveform	78
ADC sample rate	92, 108
ADC samples	92
Aligning	
Input channels	391
Amplitude measurement	235
Amplitude measurements	
Minimizing results	54
Trying out	54
Amplitude/time measurements	
Settings	264
Analog	
Parallel bus display	520
Analog edge	
Trigger settings	143
Area level	
Amplitude/time measurements	266
Area measurements	238
Arranging waveforms	43, 79
Asynchronous commands	648
Audio	
Track	502
Trend	506
Auto clear	
Search results	356
Auto trigger mode	31

Auto-hide signal bar	82, 181
Auto-logon	406
Auto, trigger mode	174
Autocorrelation	298
Automatic measurements	
Configuration settings	261
display settings	275
gate settings	275
Autonaming	385
AUTOSET	
Trying out	40
AUTOSET key	28
AutoZero	125
Average	112
FFT	308
Mathematics	289
Average count	113, 175, 290
Average count (N-single count)	113, 175, 290

B

Bandwidth	
instrument	92
probe	92
Spectrum measurement	242
Bench top operation	18
Beta state	29
Biased correlation	298
Big endian	
CAN	462
LIN	472
Bit Pattern Editor	425
Bit string	
serial pattern, MSO	534
Blackman Harris window (FFT)	308
Blind time	113
Boolean parameters	645
Border color	190
Bug report	1140
Burst width	236
Buses	
Node labels	422

C

Cable, USB	37
CAN	
Configuration settings	457
Data length	462
Data pattern	462
Endianess	462
Frame types	461
ID type	461
Identifier	461
Sample point	458
Transfer order	462
Trigger settings	459
Trigger types	460
Case-sensitivity	
SCPI	641
CD-ROM drive	23
Center frequency	
spectrum measurement	273

- Center point
 - Zoom 197
 - CH <n> keys 32
 - Channel
 - bandwidth 273
 - center frequency 273
 - CH <n> keys 32
 - Connector 36
 - offset 117
 - Offset 32
 - settings 116
 - Waveforms 77
 - Channel power
 - Spectrum measurement 242
 - Channels
 - couple vertical settings 119
 - Cleaning 1139
 - Clear Screen Results 193
 - Clear status
 - Remote 669
 - Click on signal icon 190
 - Clock
 - Parallel bus 521
 - Colon 646
 - Color
 - Waveform 183
 - Waveforms 178
 - Color tables 185
 - Editing 178
 - Environment sensor 260, 284
 - Color theme 182
 - Comb
 - Parallel bus display 520
 - Comma 646
 - Command sequence
 - recommendation 663
 - Remote 672
 - Commands 637
 - Colon 646
 - Comma 646
 - Command line structure 646
 - Double dagger 646
 - Finding a command 664
 - GBIP, addressed 639
 - GBIP, universal 638
 - instrument control 637
 - overlapping 648
 - Question mark 646
 - Quotation mark 646
 - SCPI compliant 637
 - sequential 648
 - Syntax elements 646
 - White space 646
 - Common commands
 - Syntax 640
 - Compensation, passive probes 392
 - Computer name
 - Changing 412
 - CONDition 651
 - Configuration
 - hardware/firmware 1141
 - Connectors
 - Probe compensation 36
 - Rear panel 37
 - USB 36
 - Coupled zoom 199
 - quick access 75, 200
 - Coupling 90
 - channel 117
 - Trigger 143
 - Cross-correlation 298
 - Cursor
 - Save data lying in-between 374
 - Saving data lying inbetween 361
 - used for gating 275
 - CURSOR key 33
 - Cursor measurement
 - Peak excursion 229
 - Cursor measurements
 - configuring 222
 - disabling 223
 - Enable 225
 - Envelope wfm 227
 - Peak search 228
 - performing 222
 - results 221
 - Settings 225
 - Cursors
 - configuring display 224
 - configuring measurement 223
 - Coupling 227
 - Display 227
 - displaying 222
 - Labels 227
 - Minimizing results 53
 - Position 226
 - Quick access 75
 - Style 227
 - Track waveform 223, 226
 - Trying out 53
 - Type 226
 - Cycle area measurement 238
 - Cycle measurements 235
- ## D
- Data entry 84
 - Data length
 - LIN 472
 - Data Length Code
 - CAN 462
 - Data pattern
 - CAN 462
 - LIN 472
 - Data security 1140
 - Data2Clock
 - Search 349
 - Trigger 154
 - Trigger (MSO) 529
 - DCL 639
 - Decimation 42, 94, 111
 - Decode table
 - MSO 523
 - Decoded bus
 - Parallel bus display 520
 - DEF 644
 - Default
 - File names 365
 - Path for saving 365
 - Default measurement 231
 - Default values
 - Remote 671
 - Delay 236
 - Trigger offset 172

- Delay measurement 266
 - Delete 77
 - Device-specific commands 637
 - DHCP 412
 - Diagrams 73
 - Diagram area 26
 - Settings 187
 - Trying out 43
 - Dialog boxes 26
 - Background transparency 29
 - Font size 182
 - Theme 182
 - Transparency 182
 - Usage 83
 - Differential probe 100
 - Digital channels 511
 - Configuration settings 518
 - Configuring 515
 - Decode table 523
 - Search 514
 - Triggering 517
 - Digital filter 128
 - Digital resolution and record length 524
 - Digital signals 511
 - Digital waveforms 77
 - Display
 - Color tables 178, 185
 - Diagram settings 187
 - Intensity 184
 - Measurement information 252
 - Overview 72
 - Persistence 183
 - Settings overview 177
 - Signal bar 81, 180
 - Trying out 43
 - Waveform settings 183
 - XY-diagram 204, 206
 - Zoom 200
 - Display elements
 - Diagram area 26
 - Input box 26
 - Menu bar 26
 - Result box 26
 - Signal bar 26
 - Toolbar 26
 - DISPLAY key 29
 - Double dagger 646
 - DOWN 644
 - Duty cycle
 - Eye 239
 - Duty cycle measurement 236
 - DVI connector 38
 - DVI-D 24, 38
- E**
- Edge
 - Search conditions 342
 - Trigger 142
 - Edge count 238
 - Edge trigger
 - MSO 526
 - Electric power (math. function) 298
 - EMI suppression 22
 - Emulation 401
 - ENABLE 651
 - Enable registers
 - Remote 671
 - Endianess
 - CAN 462
 - LIN 472
 - Enhancement 110
 - Enter key 35
 - Envelope 42, 112
 - cursor measurement 223
 - FFT 308
 - Mathematics 289
 - Measurements 266
 - Envelope wfm
 - Cursor measurement 227
 - Environment sensor
 - Measurement results 231
 - Result display 284
 - Select and enable 284
 - Using 260
 - Equivalent time 110
 - Error queues
 - recommendations 663
 - Error report 1140
 - ESC key 35
 - ESE (event status enable register) 655
 - ESR 653
 - ESR (event status register) 655
 - EVENT 651
 - Event actions
 - Mask test 334
 - Event status enable register
 - Remote 669
 - Event status enable register (ESE) 655
 - Event status register
 - Remote 669
 - Event status register (ESR) 655
 - Export
 - Data 374
 - History 361
 - Include horizontal values 378
 - Integer format 378
 - Raw values 378
 - Waveform histograms 379
 - Expressions 293
 - External monitor 24, 38
 - External trigger input 38, 134
 - External trigger out 175
 - External trigger output 38
 - Extinction ratio
 - Eye 239
 - Eye
 - Amplitude 239
 - Base 239
 - Bit rate 239
 - Fall time 239
 - Height 239
 - measurement results 239
 - Rise time 239
 - Top 239
 - Width 239
 - Eye measurements
 - Characteristics 238
 - Results 238
 - Settings 270

F

Fail condition, mask test	327
Fail criteria, mask test	316
Fail rate, mask test result	317
Fall time	236
FFT	76, 298
Configuring	303
fundamentals	298
Gating	312
measurement speed	302
MSO	514
Peak excursion	229
Performance considerations	303
Setup	305, 309
Trying out	58
Window types	308
FILE	
Key	365
FILE key	28
File names	
Default	365, 385
Fill color	190
Find	
Level	77
Remote control command	87
Setting	84
FIR (math. function)	298
FIR filter	293
Firmware	
information	1141
shutdown (remote)	934
Update	407
Flattop2 window (FFT)	308
FlexRay	
Configuration settings	477
Trigger settings	480
Font size	
Dialog boxes	182
Formula Editor	
Reference	294
Using	293
Formulas	
Advanced expressions	293
Basic editor	291
Frame types	
CAN	461
Free Run, trigger mode	174
Frontend	
information	1141
Frontpanel	
information	1141

G

Gain, vertical	90
Gate	
configuration settings	275
coupled to cursor	275
coupled to zoom	275
Save data lying in-between	374
Saving data lying inbetween	361
Search	352
Search, defining	354

Gate area	
configuring	258
Coupling to zoom	276, 314, 354
Definition	276
Gating	
FFT	312
Gaussian window (FFT)	308
GBIP connector	39
GET	639
Glitch	
Search conditions	343
Trigger	145
GPIO	
address	636
interface messages	638
remote control interface	634
GPIO bus control	
Remote	670
Grid	73
GTL	639

H

Hamming window (FFT)	308
Hann window (FFT)	308
Hardware	
information	1141
Hardware check	1141, 1142
Hardware zoom	75, 200
Help	
Open	87
Search for topic	88
Using	87
HELP key	28
Hiding transparency	190
High res	111
High signal level measurement	235
Histogram measurements	
Settings	273
Histograms	240
Area	74
averaging	250
Characteristics	240
Configuring	256
Diagram	74
Exporting waveform histograms	379
Horizontal	240
hysteresis	250
jitter measurement	242
Markers	275
Measurement histograms	278
Measurement results	240
Measurements	56
Quick access	76
Saving waveform histograms	379
Setup	285
Toolbar icons	256
Trying out	56
tubes	251
Vertical	240
History	207
Export	361, 374
MSO	512
time stamp	213
Trying out	51
Ultra Segmentation	113
HISTORY key	34

- Hold time 267
- Holdoff 168
 - TV trigger 159
 - Using 136
- Horizontal
 - Controls 29
 - Display settings 73
 - Position 30
 - Reference point 30
 - Time base 105
- HORIZONTAL key 29
- Horizontal position 96
- Humidity measurement 260, 284
- Hysteresis
 - configuring 250
 - histograms 250
 - Noise rejection, search 359
 - reference level 244, 245
 - trigger 166
- I**
- I/Q mode 29
- I²C
 - Basics 426
 - Configuration settings 428
 - Configuring 428
 - decoding results 436
 - Trigger settings 430
 - Triggering 430
- Icons
 - Measurement 253
 - Measurement status 232
- ID type
 - CAN 461
- Identification
 - Remote 669
- Identifier
 - CAN 461
 - LIN 471
- IFC 639
- INF 644
- Infinite persistence 184
- Information on display 72
- Input 36
- Input box 26
- Instrument messages 637
- Instrument settings
 - Loading 366
 - Recall 671
 - Save 671
 - Saving 362, 366
- Intensity 184
- INTENSITY 29
- Intensity of display elements 29
- Interface messages 638, 639
- Interfaces
 - GPIB 636
 - LAN 635
- Interlaced scanning 162
- Interleaved X/Y 378
- Interleaving 93
- Interpolated time 110
- Interrupt 660
- Interval
 - Search conditions 347
 - Trigger 151
- IP address 635
 - Changing 412
- IST 653
- IST flag 655
 - Remote 670
- J**
- Jitter
 - measurement via histogram 242
- Jitter measurements
 - Settings 547
- K**
- Kaiser Bessel window (FFT) 308
- Keep Y-grid fixed 188
- Keyboard
 - Connecting 22
 - On-screen 84
 - Usage 71
- Keypad 84
- Keys
 - FILE 365
 - Setup (instrument) 393
- Keywords
 - see Mnemonics 640
- L**
- Label lists 422
- Labels
 - Waveform 191
 - Waveforms 191
- LAN
 - Configuration 410
 - Connector 38
 - interface 635
 - IP address 635
 - remote control interface 634
 - resource string 635
 - VXI protocol 636
- LEVEL key 31
- Level measurements 235
- License key
 - Options 409
- Limit checks
 - Actions 282
 - configuring 257
 - enabling 263
 - performing 257
 - valid range 263
 - Violation settings 282
- Limits
 - defining 263
- LIN
 - Configuration settings 468
 - Data length 472
 - Data pattern 472
 - Endianness 472
 - Identifier 471
 - Transfer order 472
 - Trigger settings 470
 - Trigger types 470
- Little endian
 - CAN 462
 - LIN 472

- LLO 639
- Load instrument settings 671
- Loading 360
 - Instrument settings 366
- Lock touchscreen 29
- Logic analyzer functions 510
- Logic probe connector 39
- Logical operations on channels 164
- Logical Thresholds
 - MSO, configuring 516
 - MSO, settings 522
- Logon 406
- Long term measurements
 - Horizontal scale 281
 - Number of points 281
 - Period of time per point 281
 - Scale mode 281
- Long Term Measurements
 - Saving 382
- Long-term measurements
 - Basics 234
 - Configuring 259
 - Settings 278
- Low signal level measurement 235
- LXI
 - Browser interface 415
 - Configuration 413
 - LAN configuration 417
 - Ping 418
- M**
- Main measurement 265
- Mainboard
 - information 1141
- Malfunctions
 - reacting 663
- Margins
 - defining 263
- Marker limit
 - Histograms 275
- Markers
 - Example 50
 - Histograms 240, 275
- Mask definition
 - Settings 328
 - Type 326
- Mask setup 328
- Mask test 316
 - Display settings 336
 - display, configuring 322
 - event actions, configuring 322
 - Event actions, settings 334
 - Fail condition 327
 - fail criteria 316
 - fail criteria, configuring 322
 - History, testing 325
 - performing 324
 - Quick access 76
 - results 316
 - setting up 322
 - starting 324
 - State, mask test result 324
 - Test settings 325
 - Trying out 64
 - Violation tolerance 327
- Mask testing 316
- Masks
 - creating user mask 318
 - definition 316
 - Definition 328
 - Load settings 327
 - loading 324
 - modifying user mask 319
 - Save settings 327
 - saving 324
 - Segments, point settings 330
 - Segments, settings 329
 - User mask definition 328
 - Waveform mask definition 331
- MASKS key 33
- MATH key 32
- Math waveforms 32, 77
 - Arithmetic 289
 - Basic editor 291
 - displaying 287
 - enabling (remote) 847
 - FFT 298
 - FFT Gating 312
 - FFT Setup 305, 309
 - Formula editor 293
 - Operators 292, 294
 - saving 287
 - Scaling 289
 - Setup 288
 - Trying out 61
- MAX 644
- Max value measurement 235
- Maximum sample rate 93
- Mean measurement 235
- MEAS key 33, 253
- Measurement
 - Basics 230
 - Quick access 76
- Measurement histograms 278
- Measurement types
 - Amplitude 235
 - Amplitude/time 234
 - area 238
 - Counting 238
 - Eye 238
 - Histograms 240
 - spectrum 242
 - Time 236
- Measurements
 - Additional 265
 - Configuring 254
 - Default 231
 - Delay 266
 - Histograms 56
 - Icons in results table 232
 - Main 265
 - MSO 513, 518
 - Multiple 231
 - Pulse train count 268
 - Results 232
 - Setup/Hold 267
 - Starting 253
 - Statistics 233
- Median
 - Histograms 240
- Memory 207
- Menus
 - Setup (instrument) 393

- Messages
 - commands 637
 - instrument 637
 - instrument responses 638
 - interface 638
 - Micro button 99, 125
 - MIN 644
 - Min value measurement 235
 - Minimized waveform 78
 - Mixed signal option 511
 - Mixed Signal Option 39, 510
 - Mnemonics 640
 - Optional 642
 - MODE
 - Trying out 40
 - MODE key 29
 - MODE key (trigger) 31
 - Monitor 24, 38, 391
 - Mouse 23
 - Connecting 22
 - Usage 71
 - MSO 39, 510, 511
 - cursor measurements 513
 - FFT 514
 - History 512
 - measurements 513
 - Measurements 518
 - Resolution, record length 524
 - time measurements 513
 - Time qualification 531
 - trigger settings 524
 - Zoom 512
 - Multiple
 - Measurement results 231
 - Multiple measurement 278
- N**
- N dB down
 - Spectrum 273
 - NAN 644
 - Navigation controls
 - Data input 86
 - Overview 34
 - Navigation keys 35
 - NINF 644
 - Noise
 - Eye 239
 - hysteresis settings 166
 - Noise reject
 - Search 358, 359
 - Spectrum measurement 273
 - Normal trigger mode 31
 - Normal, trigger mode 174
 - NTransition 651
 - Numeric data entry 84
 - Numeric values
 - Special 644
- O**
- Occupied bandwidth
 - Spectrum measurement 242, 273
 - OCXO 39, 130
 - Offset
 - channel 117
 - Channel 32
 - Trigger 172
 - Trying out 47
 - On/Off key
 - Key 36
 - Online keyboard 387
 - Operating system 405
 - accessing 406
 - service packs 405
 - settings 406
 - Operation
 - Concepts 70
 - Manual 71
 - Operation complete
 - Remote 670
 - Operators
 - Basic editor, mathematics 292
 - Formula editor, mathematics 294
 - Option identification
 - Remote 670
 - Options
 - Beta state 410
 - Installing 409
 - Key 409
 - R&S RTO-B1 (MSO) 39
 - R&S RTO-B4 (OCXO) 39
 - R&S RTO-B10 (GBIP) 39
 - RTO-B4, OCXO 130
 - RTO-K4, FlexRay 476
 - Output buffer 653
 - Overlapping
 - preventing 649
 - Overlapping commands 648
 - Overshoot measurement 235
- P**
- Packing 1140
 - Parallel buses 511
 - Clock setup 521
 - Configuration settings 518
 - Configuring 515
 - Decode table 523
 - Signal selection 521
 - Triggering 517
 - Parallel poll register enable
 - Remote 671
 - Parameters
 - Block data 646
 - Boolean 645
 - SCPI 643
 - Special numeric values 644
 - String 646
 - Text 645
 - Units 644
 - Passive probe
 - overview 98
 - Settings 120
 - Password 406
 - Pattern
 - qualification, state trigger 164
 - Pattern search condition 156
 - Pattern trigger 156
 - MSO 531
 - Peak detect 42, 111
 - Peak excursion
 - Cursor measurement 229
 - Search 229

- Peak search
 - Configuring 228
 - cursor measurement 223
 - Cursor measurement 221
 - Spectrum measurement 221, 228
 - Peak to peak measurement 235
 - Performance
 - Considerations 231
 - Considerations for FFT 303
 - FFT parameters 302
 - Information 193
 - Performance test 132
 - Persistence
 - Settings 183
 - Ping 418
 - Position
 - Horizontal 30, 96
 - Signal bar 189
 - Vertical 32, 90
 - Position mode 192
 - Power
 - Connector 38
 - Power key
 - Key 36
 - PPC 639
 - PPE 653
 - PPE register 655
 - PPU 639
 - Preset 368
 - PRESET key 28
 - PRINT key 28
 - Printer 23
 - Color mode 360
 - Configuring 360
 - Output 360
 - Paper format 360
 - Printing 360
 - functions 387
 - results 360
 - screenshots 360
 - Trying out 67
 - Probability markers
 - Histograms 275
 - Probemeter
 - measurement 235
 - ProbeMeter 99, 124
 - Probes
 - active 99
 - AutoZero 125
 - Compensation 37
 - compensation of passive probes 391
 - differential 100
 - passive 98
 - passive, compensation 392
 - Setup 119
 - Progressive scanning 162
 - Projector 24
 - Protocol
 - VXI 636
 - PROTOCOL key 34
 - Protocols
 - CAN configuration settings 457
 - FlexRay configuration settings 477
 - FlexRay trigger settings 480
 - I²C configuration settings 428
 - I²C decoding results 436
 - I²C trigger settings 430
 - Label lists 422
 - LIN configuration settings 468
 - LIN trigger settings 470
 - SPI configuration settings 441
 - SPI decode results 447
 - SPI trigger settings 444
 - UART decode results 454
 - PTTransition 651
 - Pulse count 238
 - Pulse train count 268
- ## Q
- Q-factor
 - Eye 239
 - Queries 637, 647
 - Status 661
 - Question mark 646, 647
 - Quick save/set 366
 - Quotation mark 646
- ## R
- R&S RTO-B1 510
 - Rackmounting 19
 - Real time 110
 - Recall instrument settings 671
 - Recall intermediate 671
 - Recommendations
 - remote control programming 663
 - Record length 92, 96, 108
 - Rotary knob 30
 - Rectangular window (FFT) 308
 - Redo 75
 - REDO key 35
 - REF IN/OUT 39
 - REF key 32
 - Reference levels
 - Configuring 244
 - defining 245
 - determining 244
 - displaying 246, 278
 - hysteresis 244, 245
 - Level settings 248
 - parameters 244
 - Settings 246
 - tubes 244, 245
 - Reference point 30, 96
 - Reference signal 39
 - 1 GHz, internal 132
 - external 130
 - OXCXO 130
 - Reference waveforms 32, 77
 - displaying 214
 - loading 214
 - saving 214
 - Registers 653
 - Remote commands
 - Finding a command 664
 - Remote control 70
 - basics 634
 - Find command using help 87
 - GPIB address 636
 - interfaces 634
 - protocols 634
 - starting 636
 - Remote Desktop 70, 410

- Remote operation 70
 - Required, Ultra Segmentation 113, 175, 290
 - RES / REC LEN key 29
 - Reset
 - Histogram, long term meas., statistics 280
 - Reset values
 - Remote 671
 - Resolution 90, 92, 96, 108
 - Rotary knob 30
 - Resolution enhancement 94, 110
 - Resource string
 - LAN 635
 - Restoring
 - Settings 364
 - Result Box
 - Default position 190
 - Result boxes 26
 - Background transparency 29
 - Displaying 80
 - Transparency 182
 - Result lines
 - Displaying 278
 - Results
 - clearing 253
 - Clearing statistics 278
 - Configuring display 80
 - intermediate 246
 - mask test 316
 - Measurements 232
 - Reset long term measurement 280
 - Saving 381
 - Rise time 236
 - RMS
 - Acquisition setting 111
 - RMS measurement 235
 - Robust trigger 141
 - Roll mode 107
 - Time for automatic activation 107
 - Rotary knobs
 - Trying out 47
 - RS232
 - basics 448
 - Configuration 448
 - RTO-B4 39
 - RTO-B10 39
 - RTO1044 93
 - RTOServiceReporter 1140
 - Run 31
 - RUN CONT key 31
 - RUN N× SINGLE key 31
 - Runt
 - Search conditions 345
 - Trigger 147
- S**
- Sample hits, mask test result 317
 - Sample point (CAN) 458
 - Sample rate 92, 108
 - Samples 92
 - History 207
 - Save instrument settings 671
 - Save intermediate 671
 - Save/Recall
 - Instrument settings 366
 - Remote 913
 - User preferences 367
 - Waveforms 374
 - Saveset 366
 - SaveSet 362
 - Saving 360
 - File name generation 385
 - History 361, 374
 - Instrument settings 362, 366
 - Long Term Measurements 382
 - Preset 368
 - results 360
 - Results 381
 - screenshots 360
 - Trying out 67, 68
 - User preferences 367
 - Waveform histograms 379
 - Waveform segments 361, 374
 - Waveforms 361, 374
 - Scale
 - Horizontal, rotary knob 30
 - Trying out 47
 - Vertical 90
 - Vertical, rotary knob 32
 - Scaling
 - Horizontal 106
 - Long term measurements 280
 - Long term measurements, horizontal 281
 - Math waveforms 289
 - Measurement histograms 280
 - vertical 118
 - Scanning system (TV signals) 162
 - SCPI
 - Finding a command 664
 - Parameters 643
 - Syntax 640
 - version 634
 - SCPI compliant commands 637
 - Screen resolution 24
 - Screenshots 67, 387
 - SDC 639
 - Search
 - Auto clear 356
 - Clearing results 356
 - Conditions 338
 - Control 338
 - Copy trigger settings 343
 - Data2Clock 349
 - Definition 338
 - Edge 342
 - Enable 341
 - Gate 352
 - Glitch 343
 - In Help 88
 - Interval 347
 - Noise rejection 358
 - Noise rejection, defining 359
 - On digital signals 514
 - Peak excursion 229
 - Quick access 76
 - Result box 339
 - Results display 355
 - Runt 345
 - Scope 338
 - Show results 355
 - Slew rate 348
 - Sorting results 355
 - Source 341

- Timeout 347
- Trigger level 343, 344, 345, 347, 348
- Trigger Search 342
- Trying out 62
- Width 344
- Window 346
- Zoom window 356
- Zoom window, configuring 358
- Search conditions
 - Pattern 156
- SEARCH key 33
- Search zoom window 339
- Secured environment 1140
- Select 75
 - Waveform 78
- Selected waveform 78
- Self-alignment 391, 669
- Selftest 1141, 1142
 - Remote 672
- Sensor
 - Select and enable 284
- Sensors
 - Measurement results 231
 - Result display 284
 - Using 260
- Sequential commands 648
- Serial pattern trigger
 - MSO 534
- Serial Pattern trigger 157
- Service packs 405
- Service request (SRQ) 654, 660
- Service request enable
 - Remote 672
- Service request enable register (SRE) 654
- Setting commands 637
- Settling time 236
- Setup
 - key (instrument setup) 393
 - Keys 28
- SETUP
 - Trying out 40
- Setup and Hold
 - see Data2Clock 154
- SETUP key 28
- Setup time 267
- Setup/Hold measurement 267
- Setup/Hold ratio 267
- Show labels 192
- Shut down 21
- Shutdown
 - firmware (remote) 934
- Signal bar 26
 - Adjusting 81, 180
 - Auto-hide 82, 181
 - Border color 190
 - Colors 82, 181
 - Fill color 190
 - Hide and show 81, 180
 - Hiding 189
 - Position 189
 - Transparency (hiding) 190
- Signal colors
 - Editing 178
- Signal icons 73
- Signal label 73
- Signal levels
 - Configuring 244
- SIGNAL OFF key 32
- Signal threshold
 - Amplitude/time measurements 266
- Signal view 73
- Signals
 - Color settings 185
- Skew 131
- Slew Rate
 - Search conditions 348
 - Trigger 152
- SLOPE
 - Trying out 40
- SLOPE key 31
- SmartGrid 43, 79
- SOURCE key 31
- SPD 639
- SPE 639
- Special characters
 - SCPI 643
- Spectrum measurements
 - Channel BW 273
 - Channel CF 273
 - cursor measurement 223
 - Cursor measurement 221
 - N dB down 273
 - Noise reject 273
 - occupied bandwidth 273
 - peak detection 223
 - Peak search 221
 - results 242
 - Settings 271
 - Trying out 58
- SPI
 - Configuration settings 441
 - Configuring 440
 - decode results 447
 - Trigger settings 444
 - Triggering 444
- SPI protocol
 - basics 439
- SRE 653
- SRE (service request enable register) 654
- SRQ (service request) 654, 660
- Standard
 - TV trigger 160
- Standard deviation
 - Histograms 240
- Standard deviation measurement 235
- Start up 21
- State trigger 155
 - MSO 530
- State, mask test result 317
- Statistics
 - Compiling 259
 - Enable 278
 - Enabling 260
 - Measurement results 233
 - Settings 259
- Status
 - Measurements 232
 - Queries 661
- Status byte
 - Remote 669, 672
- Status registers
 - CONDition 651
 - ENABLE 651
 - EVENT 651

- model 651
 - NTRansition 651
 - overview 652
 - parts 651
 - PTTransition 651
 - STATus:OPERation 656
 - Status reporting system
 - Common commands 668
 - Status reports 650
 - application 660
 - STB 653
 - Storing 1140
 - Style (waveforms) 184
 - Suffixes 642
 - Switch off
 - Instrument 21
 - Waveform 80
 - Switch on
 - Instrument 20
 - Waveform 78
 - Switching of transitions 238
 - Symbolic names, see Label lists 422
 - Syntax elements
 - SCPI 646
- T**
- T-SCREEN LOCK key 29
 - Tektronix emulation (remote control) 401
 - Temperature
 - Changes 391
 - Temperature measurement 284
 - Temperature measurement 260
 - Termination 90
 - Test result, mask test result 318
 - Text entry 84
 - Theme
 - Dialog boxes 182
 - Thresholds
 - MSO, configuring 516
 - MSO, settings 522
 - Time base 30, 96, 105, 106
 - Time measurements 236
 - Time qualification
 - MSO 531
 - Time scale 30, 96, 106
 - Time stamp 213
 - Timeout
 - Search conditions 347
 - Trigger 150
 - Timeout trigger
 - MSO 528
 - Toolbar 74
 - Configuration 192
 - Coupled zoom 75, 200
 - Cursor 75
 - Delete 77
 - FFT 76
 - Find level 77
 - Hardware zoom 75, 200
 - Hide/show icons 77, 183
 - Histogram 76
 - Histogram icons 256
 - Masks 76
 - Measurement 76, 253
 - Overview 75
 - Redo 75
 - Search 76
 - Select 75
 - Show signal bar 75
 - Show tooltips 75
 - Undo 75
 - Zoom 75, 200
 - Tooltips 75
 - Show 87
 - Total harmonic distortion
 - Spectrum measurement 242
 - Touchscreen
 - Adjusting 392
 - Compared with mouse 71
 - Display overview 26
 - Lock, unlock 29
 - Usage 71
 - Track 502
 - Enable 278
 - Track waveform
 - cursor measurement 223
 - Cursor measurement 226
 - Transfer order
 - CAN 462
 - LIN 472
 - Transition switching count 238
 - Transition trigger
 - see Slew Rate trigger 152
 - Transparency 29
 - Dialog and result boxes 182
 - Hidden signal bar 190
 - Trend 278, 506
 - Trigger
 - Analog edge 143
 - Analog trigger system 134
 - Avoid undefined state 141
 - CAN settings 459
 - Controls 30
 - Data2Clock 154
 - Data2Clock (MSO) 529
 - Delay (Holdoff) 168
 - Digital trigger system 134
 - Edge 142
 - Edge (MSO) 526
 - Event (definition) 133
 - External input 38
 - External output 38
 - External trigger input 134
 - FlexRay settings 480
 - Force 175
 - Glitch 145
 - Holdoff 168
 - I²C settings 430
 - Information 134
 - Interval 151
 - Level 31
 - Level, search 343, 344, 345, 347, 348
 - LIN settings 470
 - Mode 31, 40, 174
 - MSO settings 524
 - Offset 172
 - Pattern 156
 - Pattern (MSO) 531
 - Robust 141
 - Run 175
 - Runt 147
 - Search 342
 - Sequence (definition) 134

- Serial Pattern 157
 - Serial pattern (MSO) 534
 - Settings 73
 - Settings, copy to search 343
 - Setup/hold 154
 - Slew Rate 152
 - Slope 31, 40
 - Source 31
 - sources, MSO 524
 - SPI settings 444
 - State 134, 155
 - State (MSO) 530
 - Timeout 150
 - Timeout (MSO) 528
 - TV (video) 159
 - Width 146
 - Width (MSO) 526
 - Window 149
 - Trigger event
 - Remote 672
 - TRIGGER key 30
 - Trigger level
 - qualification, pattern trigger 165
 - Trigger offset 96
 - Trigger out
 - Pulse on limit violation 283
 - Pulse on mask test 336
 - Settings 175
 - Trigger sources
 - MSO 524
 - Trigger types
 - CAN 460
 - LIN 470
 - Trigger Types 140
 - Data2Clock 154
 - Edge 142
 - Glitch 145
 - Interval 151
 - NFC 159
 - Pattern 156
 - Runt 147
 - Serial Pattern 157
 - Slew rate 152
 - State 155
 - Timeout 150
 - TV/Video 159
 - Width 146
 - Window 149
 - Tubes
 - configuring 251
 - histograms 251
 - reference level 244, 245
 - TV trigger 159
 - Type
 - Trigger 140
- U**
- UART
 - basics 448
 - Configuration 448
 - Decode results 454
 - Ultra Segmentation 113
 - Unbiased correlation 298
 - Undersampling 92
 - Undo
 - Toolbar 75
 - UNDO key 35
 - Units 644
 - Unlock touchscreen 29
 - UP 644
 - Update
 - Firmware 407
 - USB
 - Cable 37
 - Connecting 22
 - Connector 37
 - USB flash drive 23
 - USER key 34
 - User mask
 - Settings 328
 - User name 406
- V**
- Vertical
 - Controls 31
 - Position 90
 - Position / Offset 32
 - Resolution 90
 - Scale 90
 - Vertical scale 118
 - Vertical system 90
 - VGA 24
 - Video (TV) trigger 159
 - Violation
 - Limit checks 282
 - Violation of limits
 - Actions 282
 - Violation tolerance, mask test 327
 - Virus protection 405
 - VISA 634
 - resource string 635
 - VNC 70, 410
 - VXI protocol 636
- W**
- Wait
 - Remote 672
 - Waveform
 - Arithmetic 94
 - Changing color 178
 - Color 183
 - Waveform arithmetic 112
 - Waveform count
 - Histograms 240
 - Waveform mask
 - Settings 331
 - Waveform samples 92
 - Waveforms
 - Arrange 79
 - Channel 77
 - Display intensity 29
 - Labels 191
 - Math 77
 - Minimize 79
 - Names 191
 - Overview and usage 77
 - Persistence 183
 - Reference 77
 - Saving 361, 374
 - Select 78
 - States 78

Style	184
Switch off	80
Switch on	78
XY	77
Zoom	77
Zooming	193
White space	646
Width	
Search conditions	344
Trigger	146
Width trigger	
MSO	526
Window	
Search conditions	346
Trigger	149
Windows 7	405
Windows XP	405
accessing	406
Logon	406
settings	406
Windows, access	23
X	
XY-diagram	
displaying	204
settings	206
XY-waveforms	77
Z	
Zoom	193
Area	74
Area, coupling	276, 314, 354
Center point	197
Coupled	199
Diagram	74
Methods	193
MSO	512
Multiple	198
On the touchscreen	51, 195
Position/Range	197
Procedures	194
Quick access	75, 200
Save data of zoom area	374
Saving data of zoom area	361
Search results	356
settings	202
Settings	200
Start-stop values	196
Start/Stop settings	200
Trying out	50
used for gating	275
ZOOM key	34
Zoom waveforms	77