

Keysight 81618A/9A Optical Head Interface Modules and Keysight 81623B/4B/6B/8B Optical Heads

NOTICE: This document contains references to Agilent Technologies. Agilent's former Test and Measurement business has become Keysight Technologies. For more information, go to www.keysight.com.



Notices

© Keysight Technologies 2002 - 2015

No part of this manual may be reproduced in any form or by any means (including electronic storage and retrieval or translation into a foreign language) without prior agreement and written consent from Keysight Technologies as governed by United States and international copyright laws.

Keysight Technologies, Deutschland GmbH
Herrenberger Straße 130
71034 Böblingen, Germany.

Manual Part Number

81623-90B12

Edition

Edition 6, February 2015
Edition 5, April 2007
Edition 4, April 2005
Edition 3, July 2002
Edition 2, January 2002
Edition 1, July 2001

Subject Matter

The material in this document is subject to change without notice.

Keysight Technologies *makes no warranty of any kind with regard to this printed material, including, but not limited to, the implied warranties of merchantability and fitness for a particular purpose.*

Keysight Technologies shall not be liable for errors contained herein or for incidental or consequential damages in connection with the furnishing, performance, or use of this material.

Printing History

New editions are complete revisions of the guide reflecting alterations in the functionality of the instrument. Updates are occasionally made to the guide between editions. The date on the title page changes when an updated guide is published. To find out the current revision of the guide, or to purchase an updated guide, contact your Keysight Technologies representative.

Warranty

This Keysight Technologies instrument product is warranted against defects in material and workmanship for a period of one year from date of shipment. During the warranty period, Keysight will, at its option, either repair or replace products that prove to be defective.

For warranty service or repair, this product must be returned to a service facility designated by Keysight. Buyer shall prepay shipping charges to Keysight and Keysight shall pay shipping charges to return the product to Buyer. However, Buyer shall pay all shipping charges, duties, and taxes for products returned to Keysight from another country.

Keysight warrants that its software and firmware designated by Keysight for use with an instrument will execute its programming instructions when properly installed on that instrument. Keysight does not warrant that the operation of the instrument, software, or firmware will be uninterrupted or error free.

Limitation of Warranty

The foregoing warranty shall not apply to defects resulting from improper or inadequate maintenance by Buyer, Buyer-supplied software or interfacing, unauthorized modification or misuse, operation outside of the environmental specifications for the product, or improper site preparation or maintenance.

No other warranty is expressed or implied. Keysight Technologies specifically disclaims the implied warranties of Merchantability and Fitness for a Particular Purpose.

Exclusive Remedies

The remedies provided herein are Buyer's sole and exclusive remedies. Keysight Technologies shall not be liable for any direct, indirect, special, incidental, or consequential damages whether based on contract, tort, or any other legal theory.

Assistance

Product maintenance agreements and other customer assistance agreements are available for Keysight Technologies prod-

ucts. For any assistance contact your nearest Keysight Technologies Sales and Service Office.

Certification

Keysight Technologies certifies that this product met its published specifications at the time of shipment from the factory.

Keysight Technologies further certifies that its calibration measurements are traceable to the United States National Institute of Standards and Technology, NIST to the extent allowed by the Institutes's calibration facility, and to the calibration facilities of other International Standards Organization members.

ISO 9001 Certification

Produced to ISO 9001 international quality system standard as part of our objective of continually increasing customer satisfaction through improved process control.

Keysight Technologies Sales and Service Offices

For more information about Keysight Technologies test and measurement products, applications, services, and for a current sales office listing, visit our web site:

<http://www.keysight.com/find/lightwave>

You can also contact one of the following centers and ask for a test and measurement sales representative.

United States:	1 800 829 4444 1 800 829 4433 (FAX)
Canada:	1 877 894 4414 1 800 746 4866 (FAX)
Europe:	+31 20 547 2111 +31 20 547 2190 (FAX)
Japan:	120 421 345 120 421 678 (FAX)
Mexico	(52 55) 5081 9469 (52 55) 5081 9467 (FAX)
Australia:	800 629 485 800 142 134 (FAX)
Asia-Pacific:	+852 800 930 871 +852 800 930 871 (FAX)
Latin America	+55 11 4197 3600 +55 11 4197 3800 (FAX)

Table of Contents

Getting Started with Optical Heads	9
<hr/>	
Safety Considerations	10
Safety Symbols	10
Input Power Limitations	11
Initial Inspection	11
Line Power Requirements	11
Operating Environment	12
Storage and Shipment	12
What is an Optical Head?	13
Analog Output	14
Optical input	15
Heat Sink for 81628B optical Head	15
Attaching the heat sink to the 81628B Optical Head	15
Operation	18
Accessories	19
<hr/>	
Modules and Options	20
Connector Adapters - Reference List	22
Specifications	23
<hr/>	
Definition of Terms	24
Averaging Time	24
Linearity	24
Linewidth	25
Noise	25
Offset	25
Reference conditions	26
Relative uncertainty due to polarization	26
Relative uncertainty due to speckle noise	27
Relative uncertainty (spectral ripple) due to interference	27
Return loss	28
Spectral width of optical source	28

Total uncertainty	28
Uncertainty at reference conditions	28
Wavelength range	28
Literature	29
Optical Head Specifications	30
Supplementary Performance Characteristics	36
Analog Output	36
Maximum Safe Input Power	37

Performance Tests 39

Equipment Required	40
Test Record	42
Test Failure	43
Instrument Specification	44
Functional Tests	45
Performance Tests	46
For 81628B only	46
Accuracy Test	47
Linearity Test	50
Noise Test	59
Return Loss Test	60
Relative Uncertainty due to Polarization (Optional Test)	62
Relative Uncertainty due to Interference (Optional Test)	64
Calculation Sheets	80

Cleaning Information 83

Cleaning Instructions for this Device	84
8100xA Optical Head Adapters	84
8162xx Optical Power Heads	84
Safety Precautions	85
Why is it important to clean optical devices?	86
What do I need for proper cleaning?	87
Standard Cleaning Equipment	87
Additional Cleaning Equipment	90

Preserving Connectors.....	93
Cleaning Instrument Housings.....	94
Which Cleaning Procedure should I use ?.....	95
How to clean connectors.....	95
How to clean connector adapters.....	97
How to clean connector interfaces.....	97
How to clean bare fiber adapters.....	98
How to clean lenses.....	99
How to clean instruments with a fixed connector interface.....	100
How to clean instruments with an optical glass plate	101
How to clean instruments with a physical contact interface.....	101
How to clean instruments with a recessed lens interface.....	102
How to clean optical devices which are sensitive to mechanical stress and pressure.....	103
How to clean metal filters or attenuator gratings.....	104
Additional Cleaning Information.....	105
How to clean bare fiber ends.....	105
How to clean large area lenses and mirrors.....	105
Other Cleaning Hints.....	108

Index

111

1

Getting Started with Optical Heads

This chapter introduces the features of the Keysight 81623B/4B/6B/8B Optical Heads.

Safety Considerations	10
Safety Symbols	10
Input Power Limitations	11
Initial Inspection	11
Line Power Requirements	11
Operating Environment	12
Storage and Shipment	12
What is an Optical Head?	13
Analog Output	14
Optical input	15
Heat Sink for 81628B optical Head	15
Attaching the heat sink to the 81628B Optical Head	15
Operation	18

Safety Considerations

The following general safety precautions must be observed during all phases of operation, service, and repair of this instrument. Failure to comply with these precautions or with specific warnings elsewhere in this manual violates safety standards of design, manufacture, and intended use of the instrument. Keysight Technologies assumes no liability for the customer's failure to comply with these requirements.

Before operation, review the instrument and manual, including the red safety page, for safety markings and instructions. You must follow these to ensure safe operation and to maintain the instrument in safe condition.

WARNING

The **WARNING** sign denotes a hazard. It calls attention to a procedure, practice or the like, which, if not correctly performed or adhered to, could result in injury or loss of life. Do not proceed beyond a **WARNING** sign until the indicated conditions are fully understood and met.

CAUTION

A **CAUTION** notice denotes a hazard. It calls attention to an operating procedure, practice, or the like that, if not correctly performed or adhered to, could result in damage to the product or loss of important data. Do not proceed beyond a **CAUTION** notice until the indicated conditions are fully understood and met.

Safety Symbols



The apparatus will be marked with this symbol when it is necessary for the user to refer to the instruction manual in order to protect the apparatus against damage.



Caution - hot surface



Magnetic fields - may interfere with a pacemaker.

Input Power Limitations

WARNING

Applicable to Keysight 81628B only -

Operation above 34 dBm (2.51 W) is at your own risk.

Operation at a continuous optical power, or an average optical power, greater than 34 dBm causes, in the specified operating temperature range, the metal parts (connector adapters, screws) to become hotter than the required limit (55°C) of the safety standard IEC 61010-1.

Keysight Technologies Deutschland GmbH will not be liable for any damage caused by operation above 34 dBm.

Initial Inspection

Inspect the shipping container for damage. If there is damage to the container or cushioning, keep them until you have checked the contents of the shipment for completeness and verified the instrument both mechanically and electrically.

The Performance Tests give procedures for checking the operation of the instrument. If the contents are incomplete, mechanical damage or defect is apparent, or if an instrument does not pass the operator's checks, notify the nearest Keysight Technologies Sales/Service Office.

WARNING

To avoid hazardous electrical shock, do not perform electrical tests when there are signs of shipping damage to any portion of the outer enclosure (covers, panels, etc.).

Line Power Requirements

The Keysight 81618A and Keysight 81619A Optical Head Interface Modules operate when installed in the 8163B Lightwave Multimeter, 8164B Lightwave Measurement System, and 8166B Lightwave Multichannel System.

Operating Environment

The safety information in the Keysight 8163B Lightwave Multimeter, Keysight 8164B Lightwave Measurement System, and 8166B Lightwave Multichannel System User's Guide summarizes the operating ranges for the Keysight 81618A and Keysight 81619A Optical Head Interface Modules. In order for these modules to meet specifications, the operating environment must be within the limits specified for the Keysight 8163B Lightwave Multimeter, Keysight 8164B Lightwave Measurement System, and 8166B Lightwave Multichannel System.

Storage and Shipment

This module can be stored or shipped at temperatures between -40°C and $+70^{\circ}\text{C}$. Protect the module from temperature extremes that may cause condensation within it.

What is an Optical Head?

An optical head measures the power emitted from a connected single-mode or multi-mode fiber or the power applied in an open parallel beam (with max. 5 mm diameter). The wavelength and power range depends on the sensor element.

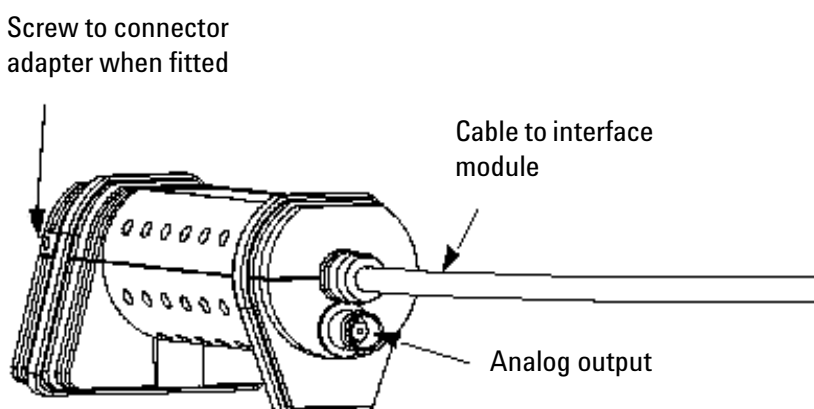

Figure 1 Rear view of an Optical Head with Analog Output

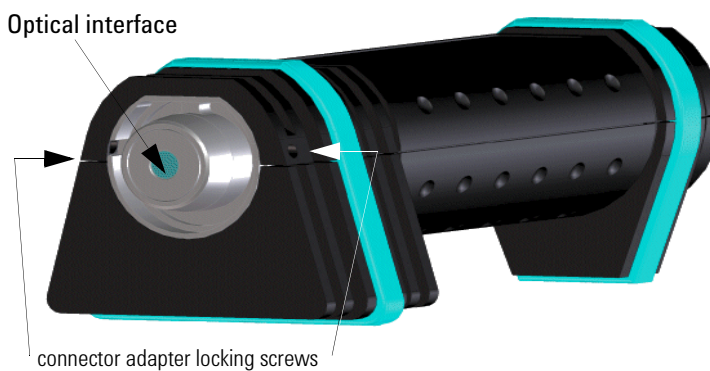

Figure 2 Front View of Optical Head without Adapter

Figure 1 and **Figure 2** show views of a typical optical head.

Figure 3 shows two types of adapter that are available for connecting the input fiber to an optical head as well as the 81624DD adapter ring that is used with threaded adapters.



Threaded connector adapter:
81000xA, 81000BT



D-shape-to-threaded adapter:
81624DD



D-type magnetic connector adapter:
(preferred)
81003xx
81001xx
81000BC

Figure 3 Connector adapters

NOTE

The optical heads are shipped including a mounted 81624DD adapter ring. To use D-type magnetic connector adapters, this ring should be removed by loosening the locking screws shown in Fig. 2 with a 1.5mm hex key.

Analog Output

The analog output is the BNC connector on the back of the optical head. It outputs a voltage directly proportional to the strength of the optical signal at the optical input in the current range. The analog signal is always in the range between 0 and 2V, 2V corresponding to a full power input signal in the current range, 0V corresponding to no input signal.

During autoranging, the level to which 2V corresponds changes. You should disable autoranging when using the analog output.

Disabling Autoranging

Select the best range for the application using the mainframes user interface. Select <Menu>, <Range Mode>, <Manual> and then choose from the list of ranges.

Applications

Possible applications for the analog output are:

- to close the feedback loop controlling the current supplied

to a laser

- to aid positioning the system for fiber alignment tasks
- to monitor optical power on an oscilloscope

The analog signal reacts instantaneously to the input signal, whereas the power shown on the display is subject to averaging.

Optical input

The optical input to the optical head requires a connector adapter to match the connector type (or bare fiber) to the optical head interface.

The optical head interface can be either threaded or a D-type magnetic interface depending on the model of optical head (81628B is only available with a threaded interface). See “[Accessories](#)” on page 19 for details of the connector adapters available.

When a connector adapter is fitted it should be locked in place by tightening the locking screws located either side of the main optical head housing.

Heat Sink for 81628B optical Head

The 81628B optical head has a heat sink that allows an extended operating power range. This heat sink must be mounted on the integrating sphere for operation from 34 dBm to 38 dBm.

Attaching the heat sink to the 81628B Optical Head

NOTE

Always attach the heat sink and rubber ring to the 81628B if operating at an optical power higher than 34dBm!

Applicable adapters

Keysight adapters types 81000xx, 81000BT are applicable to the 81628B with the heat sink attached (without the heatsink and up to 34dBm the 81000BT bare fiber adapter may be attached). Bare fibers are not intended to be used in high power applications.

NOTE

If shipping the 81628B high power optical head please detach the heatsink from the optical head to avoid damage during transportation.

Mounting Instructions

- 1 Check that the blue rubber ring is correctly attached to the integrating sphere and covers the metallic screws as shown in **Figure 4** .



Figure 4 Attaching the Rubber Ring

- 2 The heatsink consists of two conical metal parts, the bottom part (smallest diameter at the bottom), and the top part (largest diameter at top). Slide the bottom part of the heat sink over the throat of the integrating sphere with the smallest diameter facing to the sphere. Then screw on the desired adapter (81000xx series) to the sphere as shown in **Figure 5** .



Figure 5 Attaching the Bottom Part of the Heat Sink

- 3 Attach the upper part of the heat sink to the integrating sphere. Slide the upper part over the connector adapter with the largest diameter facing opposite to the sphere. Tighten the screws with the Allen key enclosed in the Heat Sink Kit (see [Figure 6](#)).

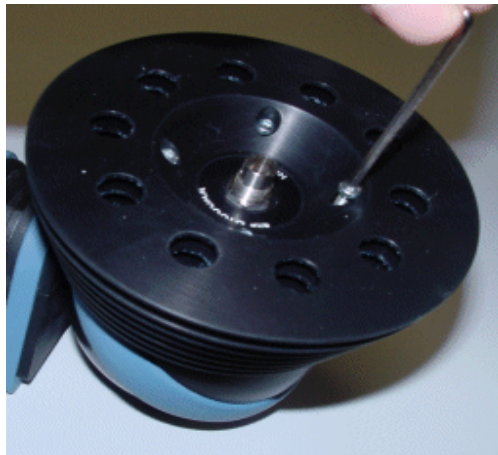

Figure 6 Attaching the Upper Part of the Heat Sink

Operation

For operating instructions, please refer to the User Guide and Programming Guide for the 816x mainframe.

2

Accessories

The Keysight 81618A/9A Optical Head Interface Modules and Keysight 81623B/4B/6B/8B Optical Heads are available in various configurations for the best possible match to the most common applications.

This chapter provides information on the available options and accessories.

Modules and Options	20
Optical Heads (5mm Sensors)	20
Connector Adapters - Reference List	22

Modules and Options

Optical Heads (5mm Sensors)

Optical Heads (5mm Sensors)

OPTIONAL



For advanced accuracy see „Special Calibration“ options C01/02 and C85/86

Interface Module

Interface Modules

- 81618A SingleHeadInterfaceModule
- 81619A DualHeadInterfaceModule

Accessories

- 81624CE 4 m extension cable
- 81624DD additional D-shape quick change adapter
- 81624RM Half-rack Mount Kit for 2 Heads
- 81625RM Rack Mount Kit for 4 Heads

Optical Heads for:
Connectorized Fiber,
Bare Fiber and
Open beam $NA \leq 0.3$

Optical Heads

- 81623B Ge
+10dBm to -80 dBm (spec for 750 – 1800nm)
- 81624B InGaAs
+10dBm to -90 dBm
- 81626B InGaAs
+27dBm to -70 dBm

D-Shaped Adapter 81624DD
(supplied with head)

Filter
Holder
[1]

Filter / Holder

- 81010BL Lens for 1300/1550 nm, single mode
- 81050BL Lens for 1300/1550 nm, multi mode

Connector Adapters (threaded)

- 81000BT Bare Fiber Connectivity Set (Threaded)
- 81000FA FC/PC/APC
- 81000KA SC/PC/APC
- 81000VA ST
- 81003LA LC
- 81000PA E-2000

Connector Adapters (threaded)

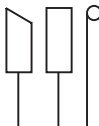

Connector Adapters (with integral D-Shape)

81624DD D-Shaped adapter not required

- 81000BC Bare Fiber Connectivity Set (D-shaped)
- 81001FA FC
- 81001KA SC
- 81001LA LC
- 81001MA MU
- 81001PA E-2000
- 81001ZA BLANK Adapter

Integral D-Shaped Adapters

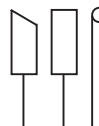

High Power Optical Head (with integrating sphere)

High Power Optical Head (with integrating sphere)

OPTIONAL



Interface Module

Interface Modules

- 81662ADFBSorce, +10dBmC-andL-band
- 81663ADFBSorce, +13dBmC-andL-band

Accessories

- 81624CE 4 m extension cable

High Power
Optical Head for:
Connectorized Fiber,
Bare Fiber and
Open beam NA ≤ 0.3

81628B InGaAs
+40 dBm to -60 dBm

Connector Adapters
(threaded)

Connector Adapters (threaded)

- 81000BT Bare Fiber Connectivity Set (Threaded)
- 81000FA FC/PC/APC
- 81000KA SC/PC/APC
- 81000VA ST
- 81003LA LC
- 81000PA E-2000

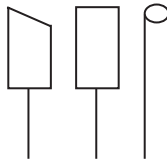

Connector Adapters - Reference List

Table 1 Connector Adapters

		Preferred Adapters
Connector Type	Threaded Version	Integral D-shape for 5 mm optical heads
Barefiber	81000BT	81000BC
FC/PC	81000FA	81001FA
SC/PC	81000KA	81001KA
MU		81001MA
E-2000	81000PA	81001PA
ST	81000VA	
blank		81001ZA
LC	810003LA	810001LA
MTP(ribbon)		81003TD

3

Specifications

The Keysight 81618A/9A Optical Head Interface Modules and Keysight 81623B/4B/6B/8B Optical Heads are produced to the ISO 9001 international quality system standard as part of Keysight Technologies' commitment to continually increasing customer satisfaction through improved quality control.

Specifications describe the modules' and heads' warranted performance. Supplementary performance characteristics describe the modules' and heads' non-warranted typical performance.

Because of the modular nature of the instrument, these performance specifications apply to these modules and heads rather than the mainframe unit.

Definition of Terms	24
Averaging Time	24
Linearity.	24
Linewidth	25
Noise	25
Reference conditions	26
Relative uncertainty due to polarization	26
Relative uncertainty due to speckle noise	27
Relative uncertainty (spectral ripple) due to interference	27
Return loss	28
Spectral width of optical source	28
Total uncertainty	28
Uncertainty at reference conditions	28
Wavelength range	28
Literature	29
Optical Head Specifications	30
Supplementary Performance Characteristics	36
Maximum Safe Input Power	37

Definition of Terms

This section defines terms that are used both in this chapter and *"Performance Tests" on page 39*.

Generally, all specifications apply for the given environmental conditions and after warm-up time.

Measurement principles are indicated. Alternative measurement principles of equal value are also acceptable.

Averaging Time

Time defining the period during which the power meter takes readings for averaging. At the end of the averaging time the average of the readings is available (display- or memory-update). Symbol T_{avg} .

Linearity

Specifies the relative difference between the displayed power ratio, D_x/D_0 , and the actual (true) power ratio P_x/P_0 caused by changing the displayed power level from the reference level, D_0 , to an arbitrary displayed level, D_x . Excluding noise and offset. Powers expressed in Watts.

if expressed in %

$$Linearity = \left(\frac{D_x/D_0}{P_x/P_0} - 1 \right) \times (100)$$

if expressed in dB

$$Linearity_{dB} = 10 \log \left(\frac{D_x/D_0}{P_x/P_0} \right)$$

Conditions: reference level 10 μ W. Power range and range setting as specified.

Note 1: Ideally Linearity is 0%, or 0 dB respectively.

Note 2: The power-dependent nonlinearity, $N(P_x)$, can alternatively be expressed by the following formula:

$$N(P_x) = \frac{r(P_x) - r(P_0)}{r(P_0)}$$

where $r(P)$ is the power-dependent responsivity (for a power meter, the responsivity is defined as the ratio of displayed power to actual input power).

Linewidth

FWHM spectral bandwidth. The 3 dB width of the optical spectrum, expressed in Hertz. Symbol: Δf .

Noise

The peak-to-peak change of displayed power level with zero input power level (dark).

Conditions: Zero prior to measurement, averaging time and observation time as specified, lowest power range selected and wavelength range as specified.

Measurement: the measurement result is obtained by:

$Noise = P_{max} - P_{min}$ expressed as peak-to-peak within the given time span. Any offset is automatically excluded this way.

Power range

The power range is defined from the highest specified input power level to the smallest input power level that causes a noticeable change of displayed power level.

Conditions: wavelength, averaging time as specified.

Offset

The average power reading without incident optical power (dark).

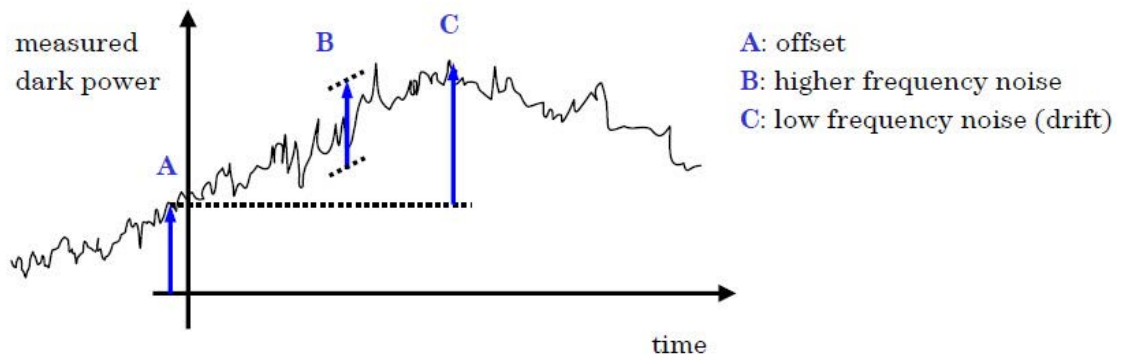

NOTE

The power meter is adjusted to zero offset by doing a zero operation with darkened power meter.

Reference conditions

The specified conditions during the spectral responsivity calibration, or conditions which are extrapolated from the conditions during calibration.

Conditions: power level, beam diameter or fiber type, numerical aperture, wavelength, spectral width, ambient temperature as specified, at the day of calibration. Noise and drift observed over a specified observation time, with a temperature change of not more than $\pm\Delta T$.

Relative uncertainty due to polarization

Also termed polarization-dependent responsivity (PDR), the relative uncertainty due to polarization is the uncertainty of the displayed power level on the input polarization state, expressed as the difference between the highest and the lowest displayed power. Uncertainty figures are based upon a 95% confidence level.

Conditions: laser source with variable polarization state, generation of all possible polarization states (covering the entire Poincaré sphere), constant wavelength, constant power level, angled connector as specified, temperature as specified.

Relative uncertainty due to speckle noise

NOTE

Spectral ripple is measured by stepping the source wavelength over the wavelength range specified.

Specifies the uncertainty of the power reading caused by optical interference (see note 1) between different optical paths within the power meters optical assembly when using a coherent source.

Conditions: constant wavelength, constant power level, angled connector as specified, linewidth of source as specified, temperature as specified.

NOTE 1

Incoming light to the integrating sphere undergoes numerous internal reflections (as many as several hundred) prior to hitting the detector. If the source is sufficiently coherent, a complicated interference pattern (speckle pattern) appears spread over the whole sphere volume. Slight changes of the ambient conditions (temperature, vibration, shock) affect particular optical paths which consequently changes the speckle pattern and results in an instability of the head power reading (speckle noise).

NOTE 2

Changes in the source wavelength have a similar effect on speckle noise as environmental changes, because they cause fluctuations in the interference pattern. If the source coherence length is small compared to the effective path length, the interference pattern disappears and relative uncertainty due to speckle noise becomes negligible.

Measurement: In contrast to the spectral ripple definition the source wavelength isn't stepped when measuring speckle noise.

Relative uncertainty (spectral ripple) due to interference

Uncertainty of power reading when using a coherent source, due to a wavelength-dependent periodic change of the power meter's responsivity caused by optical interference [1] between reflective interfaces within the power meter's optical assembly.

Conditions: constant wavelength, constant power level, angled connector as specified, linewidth of source <100 MHz, temperature as specified.

Return loss

The ratio of the incident power to the reflected power expressed in dB. Symbol: *RL*.

$$RL = 10\log\left(\frac{P_{in}}{P_{back}}\right)$$

Conditions: the return loss excludes any reflections from the fiber end used as radiation source.

Spectral width of optical source

Full width at half maximum. The 3 dB width of the optical spectrum, expressed in nm. Symbol: *FWHM*.

Total uncertainty

The uncertainty for a specified set of operating conditions, including noise and drift.

Conditions: power level, beam diameter or fiber type, numerical aperture, wavelength, spectral width, ambient temperature, re-calibration period as specified. Noise and drift observed over a specified observation time, with a temperature change of not more than $\pm\Delta T$.

Uncertainty at reference conditions

The uncertainty for the specified set of reference conditions, including all uncertainties in the calibration chain from the national laboratory to the test meter.

Wavelength range

The range of wavelengths for which the power meter is calibrated.

Note: Selectable wavelength setting of the power meter for useful power measurements (operating wavelength range).

Literature

[1] *Fiber optic test and measurement*, Hewlett Packard Professional Books, edited by Prentice Hall, ISBN 0-13-534330-5

Optical Head Specifications

All optical heads have to be operated with the single (Keysight 81618A) or dual (Keysight 81619A) Interface Modules.

Table 1 Optical Head Specifications

	Keysight 81623B	Keysight 81623B Calibration option C85 / C86	Keysight 81623B Calibration option C01 / C02
Sensor element	Ge, \varnothing 5 mm		
Wavelength range	750 nm to 1800 nm		
Power range	-80 dBm to +10 dBm		
Applicable fiber type	Standard SM and MM max 100 μ m core size, NA \leq 0.3		
Open beam	Parallel beam max \varnothing 4 mm		
Uncertainty at reference conditions ^a	\pm 2.2 % (1000 nm to 1650 nm) \pm 3.0 % typ. (800 nm to 1000 nm)	\pm 2.2 % (1000 nm to 1650 nm) \pm 2.5 % (800 nm to 1000 nm)	\pm 1.7 % (1000 nm to 1650 nm) \pm 3.0 % typ. (800 nm to 1000 nm)
Total uncertainty ^{b, c}	\pm 3.5 % \pm 100 pW (1000 nm to 1650 nm) \pm 4.0 % typ. \pm 250 pW (800 nm to 1000 nm)	\pm 3.5 % \pm 100 pW (1000 nm to 1650 nm) \pm 3.7 % \pm 250 pW (800 nm to 1000 nm)	\pm 3.0 % \pm 100 pW (1000 nm to 1650 nm) \pm 4.0 % typ. \pm 250 pW (800 nm to 1000 nm)
Relative uncertainty: - due to polarization ^d - spectral ripple (due to interference) ^e	$< \pm$ 0.01 dB ^f (typ. $< \pm$ 0.005 dB) $< \pm$ 0.006 dB (typ. $< \pm$ 0.003 dB)		
Linearity (power): ^g at 23°C \pm 5°C at operating temp. range	(CW -60 dBm to +10 dBm) ^c $< \pm$ 0.025 dB $< \pm$ 0.05 dB		
Return loss ^h	$>$ 50 dB, typ. $>$ 55 dB ⁱ		$>$ 56 dB
Noise (peak to peak) ^j	$<$ 100 pW (1200 nm to 1630 nm) $<$ 400 pW (800 nm to 1200 nm)		
Averaging time (minimal)	100 μ s		
Analog Output	included		
Dimensions	57 mm x 66 mm x 156 mm		

Table 1 Optical Head Specifications

	Keysight 81623B	Keysight 81623B Calibration option C85 / C86	Keysight 81623B Calibration option C01 / C02
Weight	0.5 kg		
Recommended recalibration period	2 years		
Operating temperature	0°C to 40°C		
Humidity	Non-condensing		
Warm-up time	40 min		

^a Reference conditions:

- Power level 10 μ W (-20 dBm), continuous wave (CW)
- Parallel beam, 3 mm spot diameter on the center of the detector
- Ambient temperature 23°C \pm 5°C
- On day of calibration (add \pm 0.3% for aging over one year, add \pm 0.6% over two years)
- Spectral width of source < 10 nm (FWHM)
- Wavelength setting at power sensor must correspond to source wavelength \pm 0.4nm

^b Operating Conditions:

- Parallel beam, 3mm spot diameter on the center of the detector or connectorized fiber with NA \leq 0.2 (straight connector, options C01 / C02 also with angled connector \leq 8°)
- Averaging time 1s
- For NA > 0.2 add 1%
- Within one year after calibration, add 0.3 % for second year
- Spectral width of source < 10 nm (FWHM)
- Wavelength setting at power sensor must correspond to source wavelength \pm 0.4nm

^c For input power > 2 mW

- add \pm 0.004 dB/mW (not for C01 / C02);
- zeroing required

^d All states of polarization at constant wavelength (1550 nm \pm 30 nm) and straight connector, T = 23°C \pm 5°C.

- For angled connector (8°) add 0.01 dB typ.

^e Conditions:

- Wavelength 1550 nm \pm 30 nm, fixed state of polarization
- Temperature 23°C \pm 5°C
- Linewidth of source \geq 100 MHz
- Angled connector 8°

^f Specification valid for optical heads with

- S/N starting with "DE413..."
- (shipping began April 1, 2001)

^g Does not include noise;

- for wavelength < 1000 nm
- applies for - 50 dBm to + 10 dBm

^h Conditions:

- Wavelengths 1550nm \pm 30 nm.
- Standard single mode fiber, angled connector min 8°

ⁱ With D-shape adapter 81001xx

- Return Loss: > 60 dB typical

^j Averaging time 1 s, T = 23°C \pm 5°C, Δ T \pm 1°C, observation time 300 s.

Table 2 High Power Optical Head Specifications

	Keysight 81624B	Keysight 81624B Calibration option C01 / C02	Keysight 81626B	Keysight 81626B Calibration option C01 / C02
Sensor element	InGaAs, \varnothing 5 mm		InGaAs, \varnothing 5mm	
Wavelength range	800 nm to 1700 nm		850 nm to 1650nm	
Power range	-90 dBm to +10 dBm		-70 to +27 dBm (1250 nm to 1650 nm) -70 to +23 dBm (850 nm to 1650 nm)	
Applicable fiber type	Standard SM and MM max 100 μ m core size, NA \leq 0.3		Standard SM and MM max 100 μ m core size, NA \leq 0.3	
Open beam	Parallel beam max \varnothing 4 mm		Parallel beam max \varnothing 4 mm	
Uncertainty at reference conditions ^a	\pm 2.2 % (1000nm to 1630 nm)	\pm 1.5 % (970 nm to 1630 nm)	\pm 3.0 % (950 nm to 1630 nm)	\pm 2.5 % (950 nm to 1630 nm)
Total uncertainty ^b	\pm 3.5% \pm 5 pW (1000nm to 1630 nm)	\pm 2.8% \pm 5 pW (970 nm to 1630 nm)	\pm 5.0% \pm 500 pW ^c (950 nm to 1630 nm)	\pm 4.5% \pm 500 pW ^c (950 nm to 1630 nm)
Relative uncertainty: ^d - due to polarization ^e - spectral ripple (due to interference) ^f	\leq \pm 0.005 dB (typ. \pm 0.002 dB) \leq \pm 0.005 dB (typ. $<$ \pm 0.002 dB)		\leq \pm 0.005 dB (typ. \pm 0.002 dB) \leq \pm 0.005 dB (typ. $<$ \pm 0.002 dB)	
Linearity (power): ^g - at 23°C \pm 5°C - at operat. temp. range	CW -70 dBm to +10 dBm, 1000 nm to 1630 nm $<$ \pm 0.02 dB $<$ \pm 0.05 dB		CW - 50 dBm to + 27dBm, 950 nm to 1630 nm $<$ \pm 0.04 dB ^c $<$ \pm 0.15 dB ^c	
Return loss ^d	typ. 60 dB		$>$ 45 dB	$>$ 47 dB
Noise (peak to peak) ^h	$<$ 5 pW		$<$ 500 pW	
Averaging time (min.)	100 μ s		100 μ s	
Analog Output	Included		Included	
Dimensions	57 mm x 66 mm x 156 mm		57 mm x 66 mm x 156 mm	
Weight	0.5 kg		0.5 kg	
Recommended recalibration period	2 years		2 years	
Operating temperature	0°C to 40°C		0°C to +35°C ⁱ	
Humidity	Non-condensing		Non-condensing	
Warm-up time	40 min		40 min	

- ^a Reference conditions:
 Power level 10 μ W (-20 dBm), continuous wave (CW)
 Parallel beam, 3 mm spot diameter on the center of the detector
 Ambient temperature 23°C \pm 5°C
 On day of calibration (add \pm 0.3% for aging over one year, add \pm 0.6% over two years)
 Spectral width of source < 10 nm (FWHM)
 Wavelength setting at power sensor must correspond to source wavelength \pm 0.4nm
- ^b Operating Conditions:
 Parallel beam, 3mm spot diameter on the center of the detector or connectorized fiber with NA \leq 0.2 (straight connector, options C01 / C02 also with angled connector \leq 8°)
 Averaging time 1s
 For NA > 0.2 add 1%.
 Within one year after calibration, add 0.3 % for second year.
 Zeroing required
- ^c For input power > + 10 mW:
 Add typ. \pm 0.0016 dB/mW. Options C01 / C02 with adaptor Keysight 81000AF and wavelength \leq 1550 nm: add \pm 0,0006 dB/mW (guaranteed).
 In case of decreasing power, allow time for stabilization of the reading (about 5 s per dB change).
 In case of decreasing power by more than 50 dB, allow recovery time of 3 minutes.
- ^d Conditions:
 Wavelengths 1550nm \pm 30 nm
 Standard single mode fiber, angled connector min 8°
 With D-shape adapter 81001xx
 Return Loss > 60 dB typical
- ^e All states of polarization at constant wavelength (1550 nm \pm 30 nm),
 straight connector, T = 23°C \pm 5°C.
 For angled connector (8°) add 0.01 dB typ.
- ^f Conditions:
 Wavelength 1550 nm \pm 30 nm, fixed state of polarization
 Temperature 23°C \pm 5°C
 Linewidth of source \geq 100 MHz
 Angled connector 8°
- ^g Does not include noise; zeroing required
- ^h Averaging time 1s, T = 23°C \pm 5°C, Δ T \pm 1°C, observation time 300 s.
 Wavelength range 1200 nm to 1630nm
- ⁱ Max 30°C for > + 20 dBm input power

Table 3 Keysight 81628B Specification

	Keysight 81628B with integrating sphere
Sensor element	InGaAs
Wavelength range	800 nm to 1700 nm
Power range	-60 dBm to +40 dBm (800 nm to 1700 nm) For operation higher than 34 dBm see safety note 
Damage Power	40.5 dBm
Applicable fiber type	Single mode NA \leq 0.2, Multimode NA \leq 0.4
Open beam	$\varnothing \leq$ 3mm center of sphere
Uncertainty at reference conditions ^{a b}	\pm 3.0 % (970 nm to 1630nm)

Table 3 Keysight 81628B Specification

	Keysight 81628B with integrating sphere
Total uncertainty ^{c b} ≤ 10 dBm >10 dBm to ≤20 dBm >20 dBm to ≤38 dBm	(970 nm to 1630nm) ± 4.0% ± 5 nW ± 4.5% ± 5%
Relative uncertainty: - due to polarization ^d - due to speckle noise at source linewidth: ^e 0.1pm to 100pm >100pm	typ. ≤ ± 0.006 dB typ. ≤ ± 0.02 dB typ. ≤ ± 0.002 dB
Linearity (power): ^{f b g} ≤ 10 dBm >10 dBm to ≤20 dBm >20 dBm to ≤37 dBm >37 dBm to ≤38 dBm	(CW –40 dBm to + 38 dBm), (970 nm to 1630 nm) ≤ ± 0.03 dB ≤ ± 0.06 dB ≤ ± 0.09 dB ≤ ± 0.10 dB
Return loss	typ. > 75 dB
Noise (peak to peak) ^h	< 5 nW
Averaging time (minimal)	100 μs
Analog Output	Included
Dimensions	55mm x 80 mm x 250 mm
Weight	0.9 kg (without heat sink)
Recommended Recalibration period	2 years
Operating temperature ⁱ	0°C to +40°C
Humidity	Non-condensing
Warm-up time	40 min

^a Power level 10 μW (-20 dBm), continuous wave (CW)
Averaging time 1s
Parallel beam, 3 mm, center of sphere input
Ambient temperature 23 °C ± 5 °C
On day of calibration (add ± 0.3 % for aging over one year, add ± 0.6 % over two years)
Spectral width of source <10 nm (FWHM)
Wavelength setting at power sensor must correspond to source wavelength ± 0.4 nm
Humidity 50 % ± 10 %

^b Wavelength must not be equal to any water absorption line

- ^c Operating Conditions:
 - Parallel beam, \varnothing 3mm , center of sphere input, or connectorized fiber with $NA \leq 0.2$ (straight connector)
 - For $NA > 0.2$: add 1%
 - Within one year after calibration, add $\pm 0.3\%$ for second year
 - Operating temperature range as specified, humidity $< 80\%$ and non-condensing
 - Zeroing required
 - ^d All states of polarization at constant wavelength ($1550 \text{ nm} \pm 30 \text{ nm}$) and constant power
 - ^e Conditions:
 - Wavelength $1550 \text{ nm} \pm 30 \text{ nm}$, fixed state of polarization, constant power
 - Temperature $23^\circ\text{C} \pm 5^\circ\text{C}$
 - Measurement time $\leq 3 \text{ min}$
 - ^f Does not include noise; zeroing required
 - ^g at $23^\circ\text{C} \pm 5^\circ\text{C}$, for operating temperature range add $\pm 0.03 \text{ dB}$
 - ^h Averaging time 1s, $T = 23^\circ\text{C} \pm 5^\circ\text{C}$, $\Delta T \pm 1^\circ\text{C}$, observation time 300 s, wavelength range 970 nm to 1630 nm
- Thermal drift at 38 dBm,
 exposure time 30 min:
 Recovery time 10 min: $\leq 30 \text{ nW}$
 30 min: $\leq 10 \text{ nW}$
- ⁱ For optical power $> 30 \text{ dBm}$ the maximal operating temperature is limited to 35°C

Safety Note:



For optical power higher than 34 dBm the attached heat sink must be used!

For continuous optical power or average optical power higher than 38 dBm the connector adapters will get warmer than permitted according to the safety standard IEC 61010-1.

The 81628B Optical Head can handle optical power up to 40 dBm, however, operation above 38 dBm is at the operators own risk.

Keysight Technologies Deutschland GmbH will not be liable for any damages caused by an operation above 38 dBm.

Supplementary Performance Characteristics

Analog Output

Bandwidth \geq DC, \leq 300 to 5000 Hz depending on range and optical head.

Output voltage 0 to 2 V non-terminated

Output impedance 600 Ohm typ.

Max. input voltage \pm 10V

Range	Bandwidth 81622B/3B	Bandwidth 81624B/6B/7B	Bandwidth 81628B
+40 dBm	N/A	N/A	3.5 kHz
+30 dBm	N/A	N/A	3.5 kHz
+20 dBm	N/A	N/A	3.5 kHz
+10 dBm	5.0 kHz	5.0 kHz	3.5 kHz
0 dBm	5.0 kHz	5.0 kHz	1.8 kHz
-10 dBm	5.0 kHz	5.0 kHz	1.8 kHz
-20 dBm	5.0 kHz	5.0 kHz	0.12 kHz
-30 dBm	0.5 kHz	1.8 kHz	0.12 kHz
-40 dBm	0.5 kHz ^a	1.8 kHz	N/A
-50 dBm	0.05 kHz ^a	0.12 kHz ^b	N/A
-60 dBm	0.05 kHz ^a	0.12 kHz ^b	N/A

^a Not applicable for 81622B

^b Not applicable for 81626B

Maximum Safe Input Power

Model	Maximum Safe Input Power
81623B	+16 dBm
81624B	+16 dBm
81626B	+23.5 dBm (850 nm to 1650 nm) +27.5 dBm (1250 nm to 1650 nm)
81628B	+40.5 dBm

4

Performance Tests

The procedures in this section test the performance of the instrument. The complete specifications to which Keysight 81623B/4B/6B/8B Optical Heads are tested are given in *"Specifications" on page 23*. All tests can be performed without access to the interior of the instrument. The test equipment given corresponds to tests carried out with Diamond HMS - 10 connectors.

Equipment Required	40
Test Record	42
Test Failure	43
Instrument Specification	44
Functional Tests	45
Performance Tests	46
For 81628B only.	46
Accuracy Test	47
Linearity Test	50
Noise Test.	59
Return Loss Test	60
Relative Uncertainty due to Polarization (Optional Test)	62
Relative Uncertainty due to Interference (Optional Test)	64
Calculation Sheets	80

Equipment Required

Equipment required for the performance test is listed in the table below. Any equipment that satisfies the critical specifications of the equipment given in the table may be substituted for the recommended models.

Table 1 Equipment Required for Performance Test

Instrument/Accessory	Recommended Model	Interface		Optical Head				Required Characteristics	Alternative Models	
		81618A	81619A	81623B	81624B	81626B	81628B			
Multimeter Mainframe	8163A/B	1 ea	1 ea	2 ea	2 ea	2 ea	2 ea	Required Characteristics	8164A/B	
Interface Module	Keysight 81618A	–	–	x	x	x	x		Keysight 81619A	
Optical Head	8162x	1 ea	2 ea	–	–	–	–		Keysight 81657A	
CW Laser Module	Keysight 81657A	–	–	x	x	x	x			
CW Laser Module	81654A	–	–	x	x	x	x			
Power Meter Standard	Keysight 81618A Optical Head Interface Module with Keysight 81623B #C01	–	–	x	–	–	–			
Power Meter Standard	Keysight 81618A Optical Head Interface Module with Keysight 81624B #C01	–	–	–	x	x	x			
Power Sensor Module	Keysight 81634B	–	–	x	x	x	x			
Optical Attenuator	8156A #221	–	–	x	x	x	x			
Optical Attenuator	8156A #101	–	–	x	x	x	x			
Return Loss Reference Cable	Keysight 81610CC	–	–	x	x	x	x			
Return Loss Module	Keysight 81613A	–	–	x	x	x	x			
Kit, Performance Test	81628-68705	–	–	–	–	–	x			
Tunable Laser Source	8164A and 81680A #022	–	–	–	o	o	o			
Polarization Controller	11896A #025	–	–	–	o	o	o			
Legend : – not applicable; x necessary; o optional.										

Table 1 Equipment Required for Performance Test

Instrument/Accessory	Recommended Model	Interface		Optical Head				Required Characteristics	Alternative Models
		81618A	81619A	81623B	81624B	81626B	81628B		
Wavelength Independent Coupler (3 dB)	Special Tool	-	-	-	o	o	o		
Best IF Adapter	Special Tool	-	-	-	o	o	o		
Worst IF Adapter	Special Tool	-	-	-	o	o	o		
Singlemode Fiber	81101AC (2/1* ea)	-	-	x	x	x	x		
Connector Adapters	81101PC (1 ea)	-	-	-	-	-	-		
	81102SC (1 ea)	-	-	-	-	-	x		
	81113PC (3 ea)	-	-	x	x	x	x		
	81113SC (1 ea)	-	-	x	x	x	x		
	81000AA (2 ea)	-	-	x	x	x	x		
	81000SA (1 ea)	-	-	x	x	x	x		
	81001SA (1 ea)	-	-	-	-	-	-		
Connector Interfaces	81000FA (1/2*ea)	-	-	x	x	x	x		
	81001FA (1 ea)	-	-	-	-	-	-		
	81000AI (3 ea)	-	-	x	x	x	x		
	81000FI (3 ea)	-	-	x	x	x	x		
Plastic Cap	81000SI (4 ea)	-	-	x	x	x	x		
	PN 5040-9351	-	-	x	x	x	x		
Legend : - not applicable; x necessary; o optional.									

Test Record

Results of the performance test may be tabulated on the Test Record provided at the end of the test procedures. It is recommended that you fill out the Test Record and refer to it while doing the test. Since the test limits and setup information are printed on the Test Record for easy reference, the record can also be used as an abbreviated test procedure (if you are already familiar with the test procedures). The Test Record can also be used as a permanent record and may be reproduced without written permission from Keysight Technologies.

Test Failure

If the Keysight 81618A/19A Interface module or Keysight 81623B/4B/6B/8B Optical Head fails any performance test, return the instrument to the nearest Keysight Technologies Sales / Service Office for repair.

Instrument Specification

Specifications are the performance characteristics of the instrument that is certified. These specifications, listed in *"Specifications" on page 23*, are the performance standards or limits against which the Keysight 81623B/4B/6B/8B Optical Head can be tested. *"Specifications" on page 23* also lists some supplemental characteristics of the Keysight 81623B/4B/6B/8B Optical Head. Supplemental characteristics should be considered as additional information.

Keysight 81618A/19A Interface Modules are tested for functionality only.

Any changes in the specifications due to manufacturing changes, design, or traceability to the National Institute of Standards and Technology (NIST), will be covered in a manual change supplement, or revised manual. Such specifications supercede any that were previously published.

Functional Tests

The functional test applies to the Keysight 81618A/19A Interface modules.

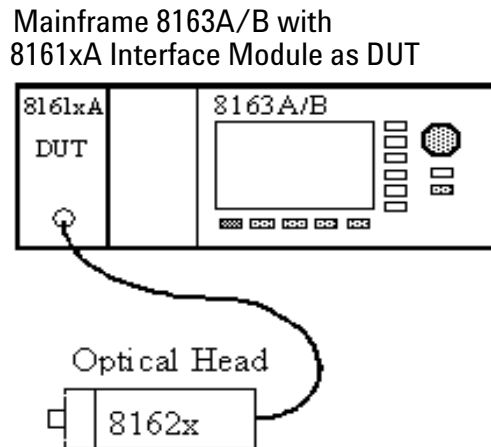

Figure 1 Functional Test Setup

- 1 Set up the equipment as shown in **Figure 1**
- 2 If you are using a Keysight 81619A Interface module connect one optical head to channel 1 and the other to channel 2
- 3 Power up the mainframe.

If the Keysight 81618A/19A passes all self-tests, the module is considered fully functional.

Performance Tests

The performance tests given in this section includes the Accuracy Test, the Linearity Test, the Return Loss Test (for the 81623B/26B) and the Noise Test. The performance tests for the Keysight 81624B/6B also include – as optional tests – the Relative Polarization Uncertainty and the Relative Interference Uncertainty Test. Perform each step in the order given, using the corresponding test equipment.

NOTE

Make sure that all optical connections are dry and clean. DO NOT USE INDEX MATCHING OIL. For cleaning, use the cleaning instructions given in *"Cleaning Information"* on page 83.

The optical cables from the laser source to the 8156A Attenuator and from there to the power meter must be fixed to the table to ensure minimum cable movement during the tests.

For 81628B only

The performance test for the 81628B High Power Head does not differ from the test procedure for an optical head without an integrating sphere, except for the linearity test. The integrating sphere of the 81628B has to be disconnected for testing the linearity of the head alone. A special adapter and a disconnecting tool are necessary for disconnection. These tools are included in the Performance Test Kit (order P/N 81628-68705).

If the integrating sphere is disconnected the performance of the 81628B has to be verified. If performing a performance test on the 81628B that includes the linearity test, it is necessary to start the procedure with the linearity test and then perform the accuracy and noise tests afterwards.

The non-linearity of the 81628B is not normally tested up to the specified power level of +38 dBm. The linearity test only verifies the linearity of the head without the integrating sphere up to 10 dBm (equivalent to 40 dBm with the integrating sphere). The attenuation of the integrating sphere is typically 31 ± 1 dB, hence the maximum input power for the photodiode is in the range 6 - 8 dBm and so the test described below covers this input power range of the photodiode. The contribution of the sphere to the non-linearity is caused by the heating of the sphere due to applied power > 30 dBm. These linearity characteristics are determined by sample testing of the 81628B in OCMD's metrology lab.

The thermal characteristics of the sphere do not change from device to device, or during the product lifetime. If a head without the sphere passes the linearity test within the specifications given on the Test Record Sheet, then the whole system - sphere and head - is within the product specification.

The head and the integrating sphere of the 81628B are adjusted and serialized together, therefore the specifications of the 81628B are only valid for that given combination of head and integrating sphere.

The disconnecting and connecting of the integrating sphere may change the performance verification data slightly.

Accuracy Test

This performance test applies to Keysight 81623B/4B/6B/8B Optical Heads.

NOTE

The linearity test must only be performed at either 1310 nm or 1550 nm. The accuracy test must be performed in the -20 dBm range at 10.0 μ W at both 1310 nm and 1550 nm.

Test Setup

- 1 Make sure that cable connector, detectors and adapters are clean.

2 Connect the equipment as shown in **Figure 2** .

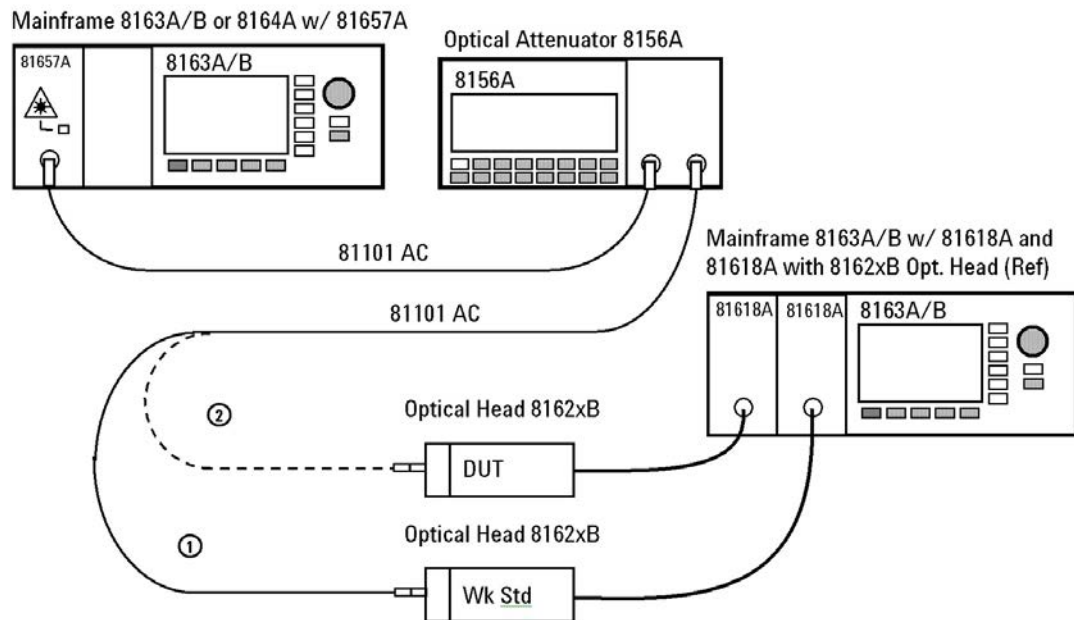

Figure 2 Accuracy Test Setup

NOTE

Make sure that the cables to and from the attenuator are fixed on the table and that both the optical head and the DUT are close together so that minimum cable movement is required when connecting the cable to the head or to the DUT.

Use 81101PC patchcord for measurement path and 81001FA connector adapter (for the DUT) and 81000FA connector adapter (for reference power meter) instead.

- 3 Move to the Laser Source channel, move to the wavelength parameter, [I], press *Enter*, select the lower wavelength source, and press *Enter*.
- 4 If you are using a Keysight 81657A Laser Source make sure you initialize the Keysight 8156A Optical Attenuator with 30 dB attenuation.
- 5 Turn the instruments on, enable the laser source and allow the instruments to warm up for at least 20 minutes.
- 6 Perform the following sub-procedure for both Power Meters:

- a Move to the Power Meter channel.
 - b Move to the wavelength parameter, [1], press *Enter*, enter the wavelength of the laser source, and press *Enter*.
 - c Move to the calibration parameter, [CAL], press *Enter*, set the calibration parameter to zero, and press *Enter*.
 - d Move to the averaging time parameter, [AvgTime], press *Enter*, move to <500 ms>, and press *Enter*.
 - e Move to the power parameter, [P], press [Pwr unit], move to <Watt>, and press *Enter*.
- 7 Make sure the optical input of the Device Under Test (DUT), 8162xA/B, is not receiving any light by placing a plastic cap over the input. Move to the DUT Power Meter channel, press [Menu], move to <Zero>, press *Enter*.
 - 8 Ensure that the Keysight 8156A output is disabled. Move to the reference Power Meter channel that uses the Keysight 8162xB Optical Head and Keysight 81618A Optical Head Interface module, press [Menu], move to <Zero>, press *Enter*.
 - 9 Enable the Keysight 8156A output and change the attenuation until the reference Power Meter displays 10.00 mW.
 - 10 Connect the attenuator output cable to the DUT Power Meter. Note the power value returned from the DUT, [P], from the display and note the result in the test record.
 - 11 Move to the Laser Source channel, move to the wavelength parameter, [1], press *Enter*, select the longer wavelength source, and press *Enter*.
 - 12 Repeat steps 4 to 10 at the second wavelength with the corresponding source.

Linearity Test

This performance test applies to Keysight 81623B/4B/6B/8B Optical Heads

NOTE

81628B only:

You have to disconnect the integrating sphere of the 81628B head to verify the linearity. Use the 81102SC high return loss patchcord to connect the DUT to the attenuator.

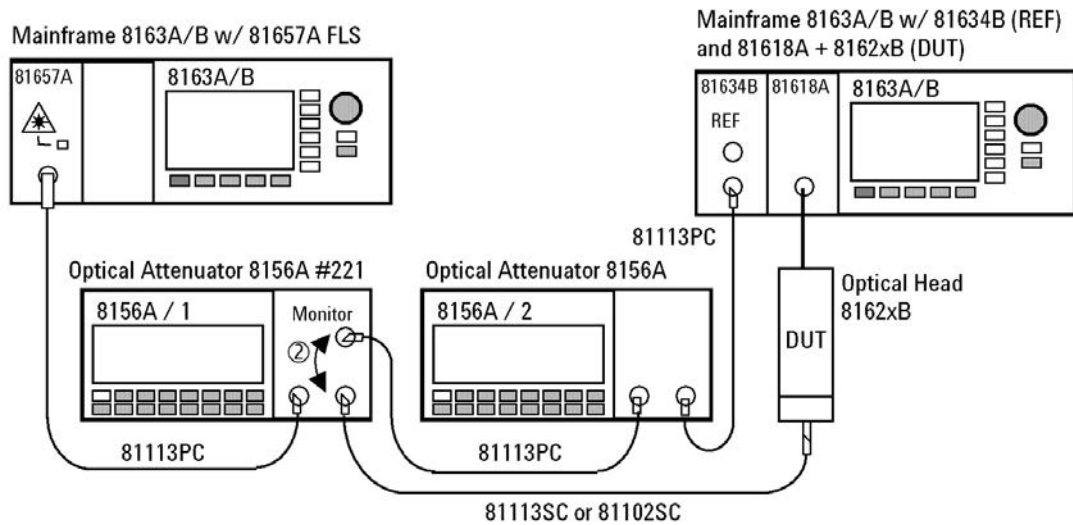

Figure 3 Measurement Setup for Power Linearity

Test Setup

NOTE

- Do not turn the laser off during the measurement!
- Clean all connectors carefully before you start with the measurement!

NOTE

The linearity test checks the in-range linearity as well as the range discontinuity. Therefore, two values are measured at the same power but within different power ranges (range discontinuity) and two different power values, one on the lower and the other on the upper limit of the power range, are measured within the same power range (in-range linearity).

Perform the test until the power reading of the DUT shows:

- for 81623B: -47.x dBm
- for 81624B: -57.x dBm
- for 81626B: -37.x dBm
- for 81628B: -57.x dBm (without sphere)

- 1 Make sure that cable connector, detectors and adapters are clean.
- 2 Make sure that you perform this test in a temperature-controlled environment with temperature fluctuations less than $\pm 1^{\circ}\text{C}$.
- 3 Setup the equipment as shown in **Figure 3** . Disable both attenuators and enable the laser source, where the source wavelength is chosen to 1550 nm. If you are using the 81657A, move to the wavelength parameter, [I], press *Enter*, select the longer wavelength source (1550 nm nominally), and press *Enter*.
- 4 Set the wavelength of both attenuators to the same wavelength as the laser source.
- 5 Perform the following sub-procedure for both Power Meters:
 - a Move to the Power Meter channel.
 - b Move to the wavelength parameter, [I], press *Enter*, enter the wavelength of the laser source, and press *Enter*.
 - c Move to the calibration parameter, [CAL], press *Enter*, set the calibration parameter to zero, and press *Enter*.
 - d Move to the averaging time parameter, [AvgTime], press *Enter*, move to <100 ms>, and press *Enter*.
 - e Move to the power parameter, [P], press [Pwr unit], move to <dBm>, and press *Enter*.
 - f Press the [Menu] softkey and move to <Number of digits>, press *Enter*, move to <3>, press *Enter* and press [Close].

NOTE

Always include at least three digits after the decimal point when you note a power reading.

- 6 Initialize the two attenuators as follows:

- a Set the attenuation of the 8156A #221 with Monitor Output (referred to as Atty1) to 0 dB.
 - b Set the attenuation of the other 8156A (referred to as Atty2) to 35 dB.
- 7 Wait at least 15 minutes until the laser source has stabilized.
- 8 Perform the following sub-procedure for the reference Power Meter, 81634B:
- a Press [Menu], move to *<Range mode>*, move to *<Manual>*, and press *Enter*.
 - b Move to *<Range>*, press *Enter*, move to *<-50 dBm>*, press *Enter*, and press [Close].
- 9 Perform the following sub-procedure for the DUT, 8162xB:
- a Press [Menu], move to *<Range mode>*, move to *<Manual>*, and press *Enter*.
 - b Move to *<Range>*, press *Enter*, move to *<10 dBm>*(40 dBm for 81628B), and press *Enter*.
 - c Zero both Power Meters. Move to *<Zero all>* and press *Enter*.
- 10 Enable both attenuators.
- 11 Adjust the attenuation of Atty2 in order to achieve -47.2 dBm on the reference Power Meter.

NOTE

For 81628B:

Before starting the measurement move to the DUT channel and enter a calibration factor of 31 dB. This simulates the disconnected integrating sphere. If the power at the DUT overflows when switching to the lower range decrease the calibration factor (e.g. to 30 dB) and start the linearity test again.

+10 dBm Range (equivalent to +40 dBm range for 81628B)

- 1 Applies to the 81626B only:
- Switch to the 20 dBm range and note both power readings as n=0 in the test record, which is given at the end of the test descriptions (#0, that is n=0). Switch back to the 10 dBm range.

- 2 Note both power readings as the first value (n=1) in the test record, which is given at the end of the test descriptions (#1).
- 3 Increase the attenuation of Atty1 until the power reading of the DUT shows about +2.8 dBm.
- 4 Note the InRange-values in the test record (#2)
- 5 At the DUT, 8162xB, move to <Range>, press *Enter*, move to <0 dBm> (30 dBm for 81628B), and press *Enter*.
- 6 Adjust the attenuation of Atty2 in order to be on the upper limit of the -50 dBm range at the reference power meter (i.e. -47.2 dBm).

0 dBm Range (equivalent to +30 dBm range for 81628B)

- 1 Disable Atty1.
- 2 Zero both Power Meters. On the 8163A/B with two installed power meters, press [Menu], move to <Zero all>, and press *Enter*.
- 3 Enable Atty1.
- 4 Switch one range up to the +10 dBm range (+40dBm for 81628).
- 5 Note both power readings (#3).
- 6 Switch down to the previous range (0 dBm, 30 dBm for the 81628B) and note the values again (#4).
- 7 Increase Atty1 by 10 dB and note the results in the test record (#5).
- 8 At the DUT, 8162xB, press [Menu], move to <Range>, press *Enter*, move to <-10 dBm>(20 dBm for the 81628B), press *Enter*, and press [Close].
- 9 If necessary, adjust the attenuation of Atty1 in order to be on the upper limit of the range (i.e. -x7.y dBm).
- 10 Decrease the attenuation of Atty2 by 10 dB in order to be on the upper limit of the -50 dBm range at the reference power meter.

-10 dBm Range (equivalent to +20 dBm range for 81628B)

- 1 Disable Atty1
- 2 Zero both Power Meters. On the 8163A/B with two installed power meters, press [Menu], move to <Zero all>, and press *Enter*.
- 3 Enable Atty1.
- 4 Switch one range up to the 0 dBm range (30 dBm for the 81628B) and note the power readings (#6).
- 5 Switch down to the previous range (-10 dBm, 20 dBm for the 81628B) and note the values again (#7).
- 6 Increase the attenuation of Atty1 by 10 dB and note the results in the test record (#8).
- 7 At the DUT, 8162xB, press [Menu], move to <Range>, press *Enter*, move to <-20 dBm>(10 dBm for the 81628B), press *Enter* and press [Close].
- 8 If necessary, adjust the attenuation of Atty1 in order to be on the upper limit of the range (i.e. -x7.y dBm).
- 9 Decrease the attenuation of Atty2 to 10 dB in order to be on the upper limit of the -50 dBm range at the reference power meter.

-20 dBm Range (equivalent to +10 dBm range for 81628B)

- 1 Disable Atty1.
- 2 Zero both Power Meters. On the 8163A/B with two installed power meters, press [Menu], move to <Zero all>, and press *Enter*.
- 3 Enable Atty1.
- 4 Switch one range up to the -10 dBm (20 dBm for the 81628B) range and note the power readings (#9).
- 5 Switch down to the previous (-20 dBm, 10 dBm for the 81628B) and note the power readings again (#10).
- 6 Increase the attenuation of Atty1 by 10 dB and note the results in the test record (#11).

- 7 On the DUT switch one range down to the -30 dBm (0 dBm for the 81628B) range.
- 8 If necessary, adjust the attenuation of Atty1 in order to be on the upper limit of the range (i.e. -x7.y dBm).
- 9 Decrease the attenuation of Atty2 by 10 dB in order to be on the upper limit of the -50 dBm range.

-30 dBm Range (equivalent to 0 dBm range for 81628B)

- 1 Disable Atty1.
- 2 Zero both power meters. On the 8163A/B with two installed power meters, press [Menu], move to <Zero all>, and press Enter.
- 3 Enable Atty1.
- 4 Switch one range up to the -20 dBm range (10 dBm for the 81628B) and note the power readings (#12).
- 5 Switch down to the previous range (-30 dBm, 0 dBm for the 81628B) and note the values again (#13).
- 6 Increase the attenuation of Atty1 by 10 dB and note the results in the test record (#14).
- 7 On the DUT switch one range down to the -40 dBm (-10 for 81628B) range.

Change Setup

- 1 Disable Atty1 and switch the output with the monitor output.
- 2 Set the attenuation of Atty1 to 35 dB and of Atty2 to 25 dB.
- 3 Enable Atty1 again.
- 4 Adjust the attenuation of both attenuators in the following order:
 - Atty1: DUT Power Meter shows a reading of -37.2 dBm.
 - Atty2: the REF Power Meter shows a reading of -47.2 dBm.

-40 dBm Range (equivalent to -10 dBm range for 81628B)

- 1 Disable Atty1.
- 2 Zero both Power Meters. On the 8163A/B with two installed power meters, press [Menu], move to <Zero all>, and press Enter.
- 3 Enable Atty1.
- 4 Switch one range up to the -30 dBm (0 dBm for the 81628B) range and note the power readings (#15).
- 5 Switch one range down (-40 dBm, -10 dBm for the 81628B) and note the power readings again (#16).
- 6 Increase the attenuation of Atty1 by 10 dB and note the results in the test record (#17).
- 7 On the DUT switch one range down to the -50 dBm range (-20 dBm for the 81628B).
- 8 If necessary, adjust the attenuation of Atty1 in order to be on the upper limit of the range (i.e. -x7.y dBm).
- 9 Decrease the attenuation of Atty2 by 10 dB in order to be on the upper limit of the -50dBm range at the reference power meter.

-50 dBm Range (equivalent to -20 dBm range for 81628B)

1. Disable Atty1.
2. Zero both power meters. On the 8163A/B with two installed power meters, press [Menu], move to <Zero all>, and press Enter.
3. Enable Atty1.
4. Switch one range up to the -40 dBm (-10 dBm for the 81628B) range and note the power readings (#18).
5. Switch one range down (-50 dBm, -20 dBm for the 81628B)) and note the power readings (#19).
6. Increase the attenuation of Atty1 by 10 dB and note the results in the test record (#20).

Calculation

10 Calculate the non-linearity using the formulas given in the test record.

Example: Measurement Results

Information only				Your Entries		Notes
n	Atty1 / #221 [dB]	Atty2 / #100 [dB]	DUT Range [dBm]	REF Power [dBm]	DUT Power [dBm]	
1	0	42	10	-47,1915	9,4273	1. Value
2	6,6	42	10	-53,769	2,8467	InRange
3	6,6	35,5	10	-47,262	2,8524	RangeDisc / lower limit
4	6,6	35,5	0	-47,2605	2,8543	RangeDisc / upper limit
5	16,6	35,5	0	-57,2304	-7,1141	InRange
6	16,6	25,5	0	-47,2363	-7,1118	RangeDisc / lower limit
7	16,6	25,5	-10	-47,2347	-7,1097	RangeDisc / upper limit
8	26,6	25,5	-10	-57,2345	-17,111	InRange
9	26,6	15,5	-10	-47,2411	.17,106	RangeDisc / lower limit
10	26,6	15,5	-20	-47,2382	-17,1054	RangeDisc / upper limit
11	36,6	15,5	-20	-57,228	-27,0942	InRange
12	36,6	5,5	-20	-47,2317	-27,0864	RangeDisc / lower limit
13	36,6	5,5	-30	-47,2318	-27,0873	RangeDisc / upper limit
14	46,6	5,5	-30	-57,2336	-37,089	InRange
15	35,5	17,6	-30	-47,219	-37,253	RangeDisc / lower limit
16	35,5	17,6	-40	-47,2195	-37,22538	RangeDisc / upper limit
17	45,5	17,6	-40	-57,1333	-47,166	InRange
18	45,5	7,6	-40	-47,1411	-47,164	RangeDisc / lower limit
19	41,2	11,3	-50	-47,1355	-47,1664	RangeDisc / upper limit
20	51,2	11,3	-50	-57,134	-57,163	InRange

Calculations

Conversion [dBm] → [mW]		Calculation as given		Calculation as given	
n	REF Power [mW] (Rn)	DUT Power [mW] (Dn)	Relation 1 (An)	Relation 2 (Bn)	Non-Linearity = $A_n \cdot B_n \cdot (NL_{n\pm 1} + 1) - 1$ [%]
1	1,90919E-05	8,76455761	0,2199125	4,5505092	0,1
2	4,19856E-06	1,926060834			
3	1,87845E-05	1,928590397	1,0003454	0,9995626	0,03
4	1,8791E-05	1,929434323	0,1006955	9,9275024	0,04
5	1,89217E-06	0,194352441			
6	1,8896E-05	0,194455396	1,0003685	0,9995166	0,08
7	1,8903E-05	0,194549447	0,1000046	10,002994	0,09
8	1,89038E-06	0,019449122			
9	1,88751E-05	0,019471526	1,000668	0,9998619	0,05
10	1,88877E-05	0,019474217	Reference Level		0,00
11	1,89322E-06	0,00195245	9,9765412	0,1002582	0,02
12	1,8916E-05	0,00195596			
13	1,89156E-05	0,001955555	1,000023	0,9997928	0,01
14	1,89078E-06	0,000195479	10,004146	0,0999609	0,01
15	1,89714E-05	0,000188235			
16	1,89692E-05	0,0001882	1,0001151	0,99981581	0,00
17	1,93495E-06	1,92044E-05	9,803474	0,1013767	0,03
18	1,93593E-05	1,92132E-05			
19	1,93997E-05	1,92026E-05	1,001013651	0,9994475	0,08
20	1,93464E-06	1,92176E-06	9,996546719	0,1000783	0,13

NOTE

The Nonlinearity is calculated recursively using n=10 as reference point. The formula is:

$$NL_n = \begin{cases} A_n \cdot B_n \cdot (NL_{n+1} + 1) - 1 & \text{for } n < 10 \\ A_n \cdot B_n \cdot (NL_{n-1} + 1) - 1 & \text{for } n > 10 \end{cases}$$

where NL_{n+1} or NL_{n-1} is the previously calculated non-linearity value. For n=1, 4, 7 the values are NL_{n+2} , while they are NL_{n-2} for n=13, 16, 19.

Linearity of 81624B

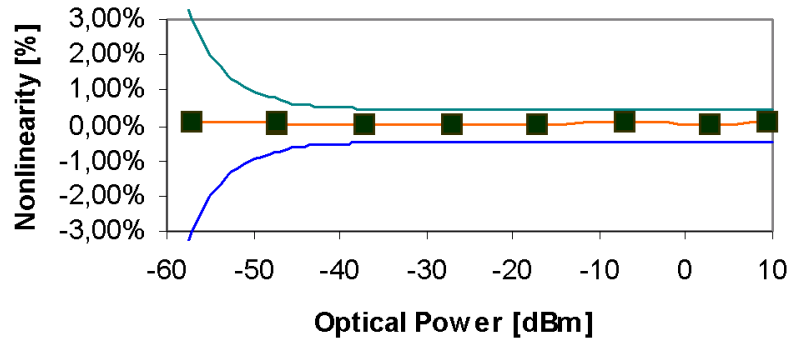

Figure 4 Example of Linearity Test Result.

Noise Test

This performance test applies to Keysight 81623B/4B/6B/8B Optical Heads.

NOTE

You must insert a module or a blank panel in the second channel position of the Keysight 8163A/B Lightwave Multimeter before you perform the noise measurement.

- 1 Insert a Keysight 81618A or a Keysight 81619A Optical Head Interface module into one slot of the Keysight 8163A/B Lightwave Multimeter and connect the device under test, an 8162xA/B Optical Head, to the Optical Head Interface module.
- 2 Make sure the optical input of the Device Under Test (DUT), an 8162xA/B Optical Head, is not receiving any light by placing a plastic cap over the input adapter. Move to the DUT Power Meter channel, press [Menu], move to <Zero>, and press *Enter*.
- 3 Press *Appl*, move to <Stability>, and press *Enter*. The Stability Setup Screen appears.
- 4 Ensure that the correct channel is selected in the upcoming Module Selection box.
- 5 Press [Menu] to access the Logging application menu screen.

- 6 Move to *<Pwr unit>*, press *Enter*, move to *<W>*, and press *Enter*.
- 7 Move to *<AvgTime>*, press *Enter*, move to *<1 s>*, and press *Enter*.
- 8 Move to *<Range mode>*, press *Enter*, move to *<Auto>*, and press *Enter*, and press [Close].
- 9 Press the [Parameter] softkey, move to [TotalTime], press *Enter*, set the total time to 00:05:00, which is 5 minutes, and press *Enter*.
- 10 Press the [Measure] softkey to start the measurement.
- 11 After the stability application has finished, press the [Analysis] softkey, press the [more] softkey, and note [DP] as the noise value in the test record.

Return Loss Test

This performance test applies to Keysight 81623B/4B/6B/Optical Heads.

- 1 Make sure that all connectors are clean.
- 2 Connect the equipment as shown in [Figure 5](#) .
- 3 Press [*Preset*] on the mainframe.

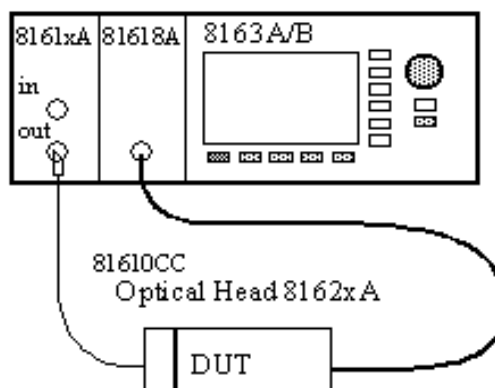

Figure 5 Return Loss Reference Setup

NOTE

To ensure traceability, use the 81610CC Reference Cable for calibration measurements. Do not use the 81610CC Reference Cable for measurements on a Device Under Test. Instead, use a measurement patchcord.

CAUTION

It is important to maintain the quality of the straight connector end of the 81610CC Reference Cable. Never add another connector to the straight end of the 81610CC Reference Cable, since a physical connection is made. When the straight end of the 81610CC Reference Cable is connected to the 81634B Power Sensor module, no physical connection is made so there should be no degradation of connector quality.

- 4 Zero the Return Loss Module and the Optical Head
- 5 Enable the internal laser source of the Return Loss Module and allow 20 minutes for it to stabilize.
- 6 At the Power Meter:
 - a Set the averaging time [*AvTime*] to 1s
 - b Set the wavelength [λ] to the wavelength of the RTL source.
 - c Set [Pwr unit] to <db>.
- 7 At the Return Loss Module:
 - a Set the averaging time [AvTime] to 1s.
 - b Enter the Return Loss Reference value RLref of the 81610CC reference cable for this wavelength.
 - c Press [RefCal] to calibrate the Return Loss module at reference condition.
- 8 At the Power Meter press [Disp -> Ref]. The Power Meter should now read 0.0 dB.
- 9 Disconnect the 81610CC Reference Cable from the setup and connect a 81113SC user cable to the Return Loss

Module and leave the other end open as shown in **Figure 8** .

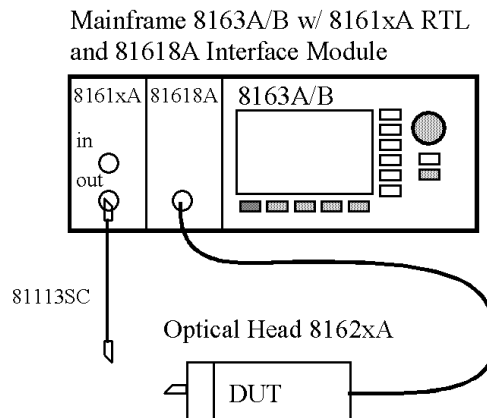

Figure 6 Return Loss Measurement Setup

10 At the Return Loss Module, press [TermCal] in order to calibrate the Return Loss Module at termination condition.

NOTE

Do not wrap the cable. The termination condition is realized with the open end of the patchcord.

11 Now connect the open end to the optical head.

12 Enter the Power reading [P] on the optical head as [FPDelta] on the Return Loss Meter. Make sure you enter the sign of this value correctly.

13 Note the Return Loss reading as the Return Loss result into the test record.

Relative Uncertainty due to Polarization (Optional Test)

NOTE

The performance test "Relative Uncertainty due to Polarization" is optional, since the polarization is given with the production of the unit by mechanical and optical cavities and is unchanged by normal use of the sensor module.

Refer to **Figure 7** for a setup to verify the relative uncertainty due to polarization of the sensor module.

Generally, during this measurement procedure the tunable laser source is swept through a predefined wavelength range. After every wavelength step, a single PDL-measurement is made, where the polarization controller generates all the different polarization states. The highest PDL value is taken as the "relative uncertainty due to polarization". The low output power path of the coupler is used to monitor the power stability of the setup.

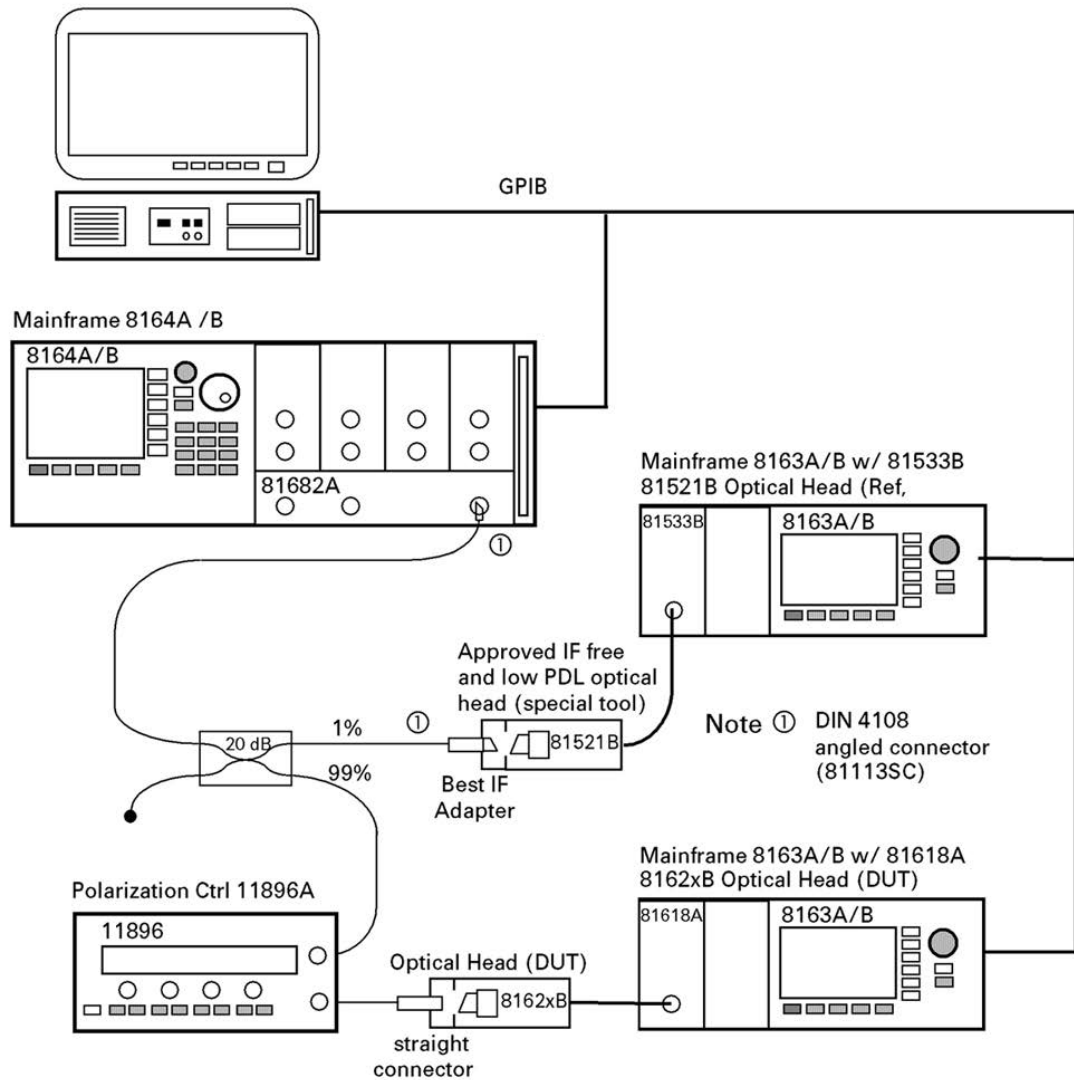

Figure 7 Measurement Setup for PDL Test

Relative Uncertainty due to Interference (Optional Test)

NOTE

The performance test "Relative Uncertainty due to Interference" is optional, since the interference is given with the production of the unit by mechanical and optical cavities and is unchanged by normal use of the sensor module.

Refer to **Figure 8** for a test setup to verify the relative uncertainty due to interference within the optical head optical assembly. In order to perform the relative uncertainty due to interference test, it is mandatory to use two mainframes, since the time difference between measurement A and B for a specific wavelength point has to be no greater than 2 ms. Due to this short measurement interval, the performance test of the Relative Uncertainty Due to Interference can only be performed under computer control.

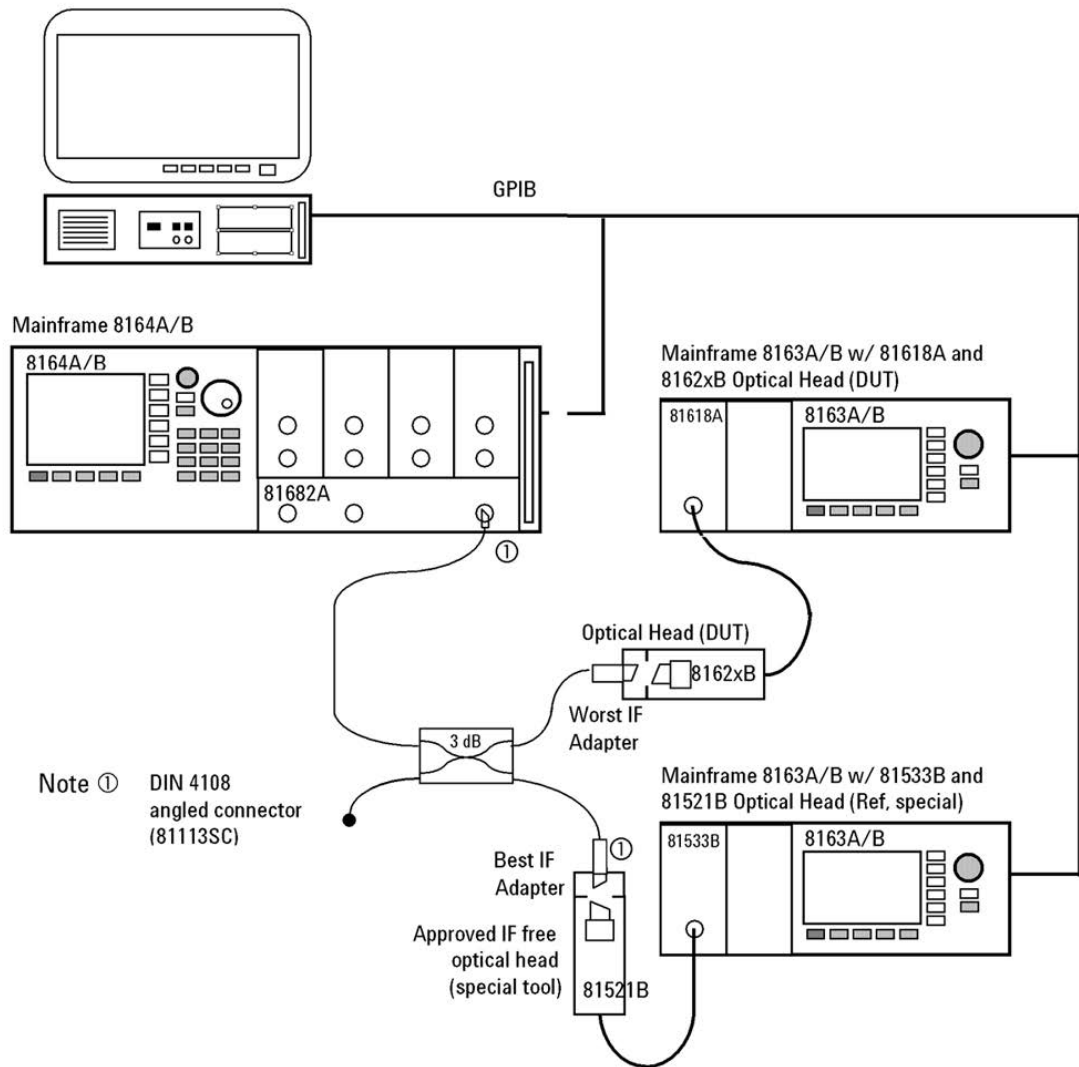

Figure 8 Setup for Relative Uncertainty due to Interference Measurement

Theoretically, both Power Meters are monitoring the power ratio over the variable wavelength in a predefined range as shown in **Figure 9**. Ensure that the tunable laser source is mode-hop free in the tested wavelength range.

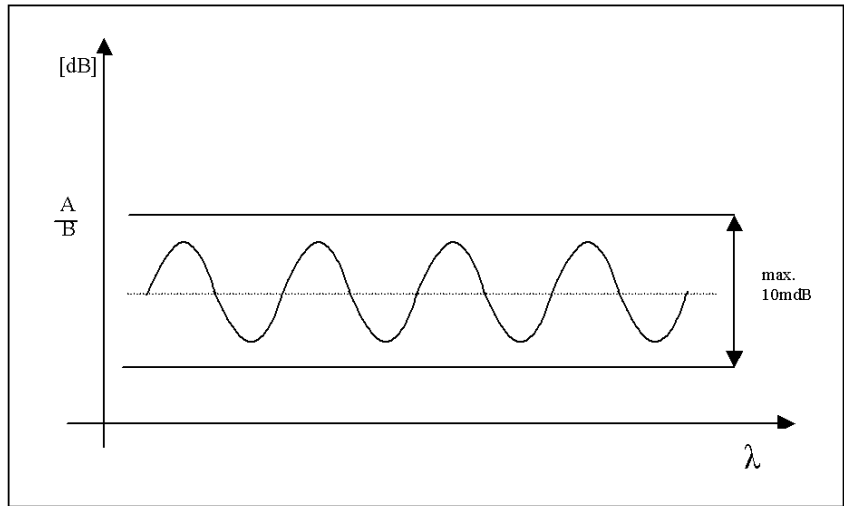

Figure 9 Interference Ripple

Performance Test for the Keysight 81623B

Page 1 of 3

Model	Keysight 81623B Optical Head_	Date	_____
Serial No.	_____	Ambient Temperature	_____ °C
Options	_____	Relative Humidity	_____ %
Firmware Rev.	_____	Line Frequency	_____ Hz

Test Facility	_____	Customer	_____
Performed by	_____	Report No	_____

Special Notes

Performance Test for the Keysight 81623B

Test Equipment Used

Page 2 of 3

	Description	Model No.	Trace No	Cal. Due Date
1a1	Lightwave Multimeter (Std.)	8163A/B	_____	_____
1a2	Lightwave Multimeter (DUT)	8163A/B	_____	_____
1b	TLS Mainframe	8164A/B	_____	_____
2a	Interface Module	Keysight 81618A	_____	_____
2b	Interface Module	Keysight 81619A	_____	_____
3a	CW Laser Source	Keysight 81656A	_____	_____
3b	CW Laser Source	Keysight 81657A	_____	_____
4	CW Laser Source	Keysight 81654A	_____	_____
5a1	Opt. Head Interface Module	Keysight 81618A	_____	_____
5a2	Optical Head, Reference	Keysight 81623B	_____	_____
6	Sensor Module	Keysight 81634A	_____	_____
7	Optical Attenuator	8156A #221	_____	_____
8a	Optical Attenuator	8156A #101	_____	_____
9	Return Loss Module	Keysight 81613A	_____	_____
10	_____	_____	_____	_____
11	_____	_____	_____	_____
12	_____	_____	_____	_____

Accessories	#	Product	#	Product	#	Product
Singlemode Fibers	2	81101AC	1	81113SC	3	81113PC
	1	81610CC				
Connector Interfaces	3	81000AI	3	81000FI	4	81000SI
Connector Adapters	2	81000AA	1	81000SA	1	81000FA

Performance Test for the Keysight 81623B

Page 3 of 3

Model Keysight 81623B Optical Head

Report No. _____

Date _____

Test No.	Test Description	Min. Spec.	Result	Max. Spec.	Measurement Uncertainty
I	Accuracy Test		[μW]		
	measured at _____ nm (1310nm) Output Power	9.72 μW	_____	10.28 μW	
	measured at _____ nm (1550nm) Output Power	9.72 μW	_____	10.28 μW	

II Linearity Test For Calculations you may want to use the appropriate sheet

Range	P_{DUT} [dBm]	P_{DUT} [dBm]	Loss [%]	
+10	+9	_____	_____	< \pm 1.13 %
+10	+3	_____	_____	< \pm 0.58 %
0	+3	_____	_____	< \pm 0.58 %
0	-7	_____	_____	< \pm 0.58 %
-10	-7	_____	_____	< \pm 0.58 %
-10	-17	_____	_____	< \pm 0.58 %
-20*	-17*	Reference	0.0	< \pm 0.58 %
-20	-27	_____	_____	< \pm 0.58 %
-30	-27	_____	_____	< \pm 0.58 %
-30	-37	_____	_____	< \pm 0.63 %
-40	-37	_____	_____	< \pm 0.63 %
-40	-47	_____	_____	< \pm 1.08 %
-50	-47	_____	_____	< \pm 1.08%
-50	-57	_____	_____	< \pm 5.59 %

III Noise Test [pW]
_____ < 100 pW

IV Return Loss Test [dB]
50 dB < _____

Performance Test for the Keysight 81624B

Page 1 of 3

Model	Keysight 81624B Optical Head_	Date	_____
Serial No.	_____	Ambient Temperature	_____ °C
Options	_____	Relative Humidity	_____ %
Firmware Rev.	_____	Line Frequency	_____ Hz

Test Facility	_____	Customer	_____
Performed by	_____	Report No	_____

Special Notes

Performance Test for the Keysight 81624B

Test Equipment Used

Page 2 of 3

	Description	Model No.	Trace No	Cal. Due Date
1a1	Lightwave Multimeter (Std.)	8163A/B	_____	_____
1a2	Lightwave Multimeter (DUT)	8163A/B	_____	_____
1b	TLS Mainframe	8164A/B	_____	_____
2a	Interface Module	Keysight 81618A	_____	_____
2b	Interface Module	Keysight 81619A	_____	_____
3a	CW Laser Source	Keysight 81656A	_____	_____
3b	CW Laser Source	Keysight 81657A	_____	_____
4	CW Laser Source	Keysight 81654A	_____	_____
5a1	Opt. Head Interface Module	Keysight 81618A	_____	_____
5a2	Optical Head, Reference	Keysight 81624A	_____	_____
6	Sensor Module	Keysight 81634A	_____	_____
7	Optical Attenuator	8156A #221	_____	_____
8a	Optical Attenuator	8156A #101	_____	_____
9	Return Loss Module	Keysight 81613A	_____	_____
10	_____	_____	_____	_____
11	_____	_____	_____	_____
12	_____	_____	_____	_____

Accessories	#	Product	#	Product	#	Product
Singlemode Fibers	2	81101AC	1	81113SC	3	81113PC
	1	81610CC				
Connector Interfaces	3	81000AI	3	81000FI	4	81000SI
Connector Adapters	2	81000AA	1	81000SA	1	81000FA

Performance Test for the Keysight 81624B

Page 3 of 3

Model Keysight 81624B Optical Head

Report No. _____

Date _____

Test No.	Test Description	Min. Spec.	Result	Max. Spec.	Measurement Uncertainty
----------	------------------	------------	--------	------------	-------------------------

I Accuracy Test

[μW]

measured at _____ nm
(1310nm) Output Power

9.72 μW

_____ 10.28 μW

measured at _____ nm
(1550nm) Output Power

9.72 μW

_____ 10.28 μW

II Linearity Test

For Calculations you may want to use the appropriate sheet

Range	P _{DUT} [dBm]	P _{DUT} [dBm]	Loss [%]
+10	+9	_____	< \pm 0.46 %
+10	+3	_____	< \pm 0.46 %
0	+3	_____	< \pm 0.46 %
0	-7	_____	< \pm 0.46 %
-10	-7	_____	< \pm 0.46 %
-10	-17	_____	< \pm 0.46 %
-20*	-17*	Reference	0.0 < \pm 0.46 %
-20	-27	_____	< \pm 0.46 %
-30	-27	_____	< \pm 0.46 %
-30	-37	_____	< \pm 0.49 %
-40	-37	_____	< \pm 0.49 %
-40	-47	_____	< \pm 0.71 %
-50	-47	_____	< \pm 0.71 %
-50	-57	_____	< \pm 2.97 %

III Noise Test

[pW]

_____ < 5 pW

IV Return Loss Test

[dB]

typ. 60 dB _____

Performance Test for the Keysight 81626B

Page 1 of 3

Model	Keysight 81626B Optical Head_	Date	_____
Serial No.	_____	Ambient Temperature	_____ °C
Options	_____	Relative Humidity	_____ %
Firmware Rev.	_____	Line Frequency	_____ Hz

Test Facility	_____	Customer	_____
Performed by	_____	Report No	_____

Special Notes

Performance Test for the Keysight 81626B

Test Equipment Used

Page 2 of 3

	Description	Model No.	Trace No	Cal. Due Date
1a1	Lightwave Multimeter (Std.)	8163A/B	_____	_____
1a2	Lightwave Multimeter (DUT)	8163A/B	_____	_____
1b	TLS Mainframe	8164A/B	_____	_____
2a	Interface Module	Keysight 81618A	_____	_____
2b	Interface Module	Keysight 81619A	_____	_____
3a	CW Laser Source	Keysight 81656A	_____	_____
3b	CW Laser Source	Keysight 81657A	_____	_____
4	CW Laser Source	Keysight 81654A	_____	_____
5a1	Opt. Head Interface Module	Keysight 81618A	_____	_____
5a2	Optical Head, Reference	Keysight 81624A	_____	_____
6	Sensor Module	Keysight 81634A	_____	_____
7	Optical Attenuator	8156A #221	_____	_____
8a	Optical Attenuator	8156A #101	_____	_____
9	Return Loss Module	Keysight 81613A	_____	_____
10	_____	_____	_____	_____
11	_____	_____	_____	_____
12	_____	_____	_____	_____

	Accessories	#	Product	#	Product	#	Product
Singlemode Fibers		2	81101AC	1	81113CC	3	81113PC
		1	81610CC				
Connector Interfaces		3	81000AI	3	81000FI	4	81000SI
Connector Adapters		2	81000AA	1	81000SA	1	81000FA

Performance Test for the Keysight 81626B

Page 3 of 3

Model Keysight 81626B Optical Head

Report No. _____

Date _____

Test No.	Test Description	Min. Spec.	Result	Max. Spec.	Measurement Uncertainty
I	Accuracy Test		[μW]		
	measured at _____ nm (1310nm) Output Power	9.64 μW	_____	10.36 μW	
	measured at _____ nm (1550nm) Output Power	9.64 μW	_____	10.36 μW	

II **Linearity Test** For Calculations you may want to use the appropriate sheet

Range	P _{DUT} [dBm]	P _{DUT} [dBm]	Loss [%]
+20	+9	_____	< \pm 1.29% ^[1]
+10	+9	_____	< \pm 0.93 %
+10	+3	_____	< \pm 0.93 %
0	+3	_____	< \pm 0.93 %
0	-7	_____	< \pm 0.93 %
-10	-7	_____	< \pm 0.93 %
-10	-17	_____	< \pm 0.93 %
-20	-17	_____	< \pm 0.93 %
-20*	-17*	Reference	0.0 < \pm 0.93 %
-20	-27	_____	< \pm 0.95 %
-30	-27	_____	< \pm 0.95 %
-30	-37	_____	< \pm 1.18 %
-40	-37	_____	< \pm 1.18 %
-40	-47	_____	< \pm 3.43 %

III **Noise Test** [pW]
_____ < 500 pW

IV **Return Loss Test** [dB]
60 dB < _____

[1] The 20 dB range measurement is only performed to check the functionality of the current booster. The published specification does not apply to operation in non-automode as used here to check the functionality.

NOTE

The nonlinearity of the 81626B is not usually tested to the specified power level of +27 dBm. Instead, limited testing up to +9 dBm is used to test the electronic circuitry of the 81626B. Above +9 dBm the largest contribution to nonlinearity is from the absorbing glass filter (which is tested on a sample basis) that does not change its linearity with time. Thus it is guaranteed by design that testing the 81626B up to +9 dBm ensures specification compliance to +27 dBm

Performance Test for the Keysight 81628B

Page 1 of 3

Model	Keysight 81628B Optical Head_	Date	_____
Serial No.	_____	Ambient Temperature	_____ °C
Options	_____	Relative Humidity	_____ %
Firmware Rev.	_____	Line Frequency	_____ Hz

Test Facility	_____	Customer	_____
Performed by	_____	Report No	_____

Special Notes

Performance Test for the Keysight 81628B

Test Equipment Used

Page 2 of 3

	Description	Model No.	Trace No	Cal. Due Date
1a1	Lightwave Multimeter (Std.)	8163A/B	_____	_____
1a2	Lightwave Multimeter (DUT)	8163A/B	_____	_____
1b	TLS Mainframe	8164A/B	_____	_____
2a	Interface Module	Keysight 81618A	_____	_____
2b	Interface Module	Keysight 81619A	_____	_____
3a	CW Laser Source	Keysight 81656A	_____	_____
3b	CW Laser Source	Keysight 81657A	_____	_____
4	CW Laser Source	Keysight 81654A	_____	_____
5a1	Opt. Head Interface Module	Keysight 81618A	_____	_____
5a2	Optical Head, Reference	Keysight 81624A	_____	_____
6	Sensor Module	Keysight 81634A	_____	_____
7	Optical Attenuator	8156A #221	_____	_____
8a	Optical Attenuator	8156A #101	_____	_____
9	Return Loss Module	Keysight 81613A	_____	_____
10	_____	_____	_____	_____
11	_____	_____	_____	_____
12	_____	_____	_____	_____

Accessories	#	Product	#	Product	#	Product
Singlemode Fibers	2	81101AC	1	81113SC	3	81113PC
	1	81610CC				
Connector Interfaces	3	81000AI	3	81000FI	4	81000SI
Connector Adapters	2	81000AA	1	81000SA	1	81000FA

Performance Test for the Keysight 81628B

Page 3 of 3

Model Keysight 81628B Optical Head

Report No. _____

Date _____

Test No.	Test Description	Min. Spec.	Result	Max. Spec.	Measurement Uncertainty
----------	------------------	------------	--------	------------	-------------------------

I Linearity Test (without sphere)

For Calculations you may want to use the appropriate sheet

Range	P _{DUT} [dBm]	P _{DUT} [dBm]	Loss [%]	
+40	+9	_____	_____	<± 0.46 %
+40	+3	_____	_____	<± 0.46 %
+30	+3	_____	_____	<± 0.46 %
+30	-7	_____	_____	<± 0.46 %
+20	-7	_____	_____	<± 0.46 %
+20	-17	_____	_____	<± 0.46 %
+10*	-17*	Reference	0.0	<± 0.46 %
+10	-27	_____	_____	<± 0.46 %
0	-27	_____	_____	<± 0.46 %
0	-37	_____	_____	<± 0.46 %
-10	-37	_____	_____	<± 0.46 %
-10	-47	_____	_____	<± 0.49 %
-20	-47	_____	_____	<± 0.49 %
-20	-57	_____	_____	<± 0.71 %

II Accuracy Test (with sphere)

[μW]

measured at _____ nm (1310nm) Output Power	9.64 μW	_____	10.36 μW
measured at _____ nm (1550nm) Output Power	9.64 μW	_____	10.36 μW

III Noise Test

[pW]

_____ < 5 nW

Calculation Sheets

Table 2 Calculation Sheet for Linearity Measurement (81623B, 81624B, 81628B)

n	Your Entries		Conversion [dBm] → [mW]		Calculation as given		Calculation as given
	REF Power [dBm]	DUT Power [dBm]	Ref / R [mW]	DUT / D [mW]	Relation1 / A = R_{n+1}/R_n	Relation2 / B = D_n/D_{n+1}	Non-Linearity = $A_n * B_n (NL_{n±1}+1) - 1$ [%]
1							
2							
3							
4							
5							
6							
7							
8							
9							
10					Reference Level		0.00
11							
12							
13							
14							
15							
16							
17							
18							
19							
20							

Table 3 Calculation Sheet for Linearity Measurement (81626B)

n	Your Entries		Conversion [dBm] → [mW]		Calculation as given		Calculation as given
	REF Power [dBm]	DUT Power [dBm]	Ref / R [mW]	DUT / D [mW]	Relation1 / A = R_{n+1}/R_n	Relation2 / B = D_n/D_{n+1}	Non-Linearity = $A_n * B_n (NL_{n±1} + 1) - 1$ [%]
1							
2							
3							
4							
5							
6							
7							
8							
9							
10					Reference Level		0.00
11							
12							
13							
14							
15							
16							
17							
18							
19							
20							

5

Cleaning Information

The following Cleaning Information contains some general safety precautions, which must be observed during all phases of cleaning. Consult your specific optical device manuals or guides for full information on safety matters.

Please try, whenever possible, to use physically contacting connectors, and dry connections. Clean the connectors, interfaces, and bushings carefully after use.

If you are unsure of the correct cleaning procedure for your optical device, we recommend that you first try cleaning a dummy or test device.

Keysight Technologies assume no liability for the customer's failure to comply with these requirements.

Cleaning Instructions for this Device

This Cleaning Information applies to a number of different types of Optical Equipment.

Sections of particular relevance to the following devices are cross-referenced below.

81000xA Optical Head Adapters

When using optical head adapters, periodically inspect the optical head's front window (see *"How to clean connector adapters" on page 97* for cleaning procedures). Dust and metal particles can be propelled through the adapter's pinhole while inserting the connector ferrule into the receptacle. These dirt particles collect on the head's front window and, if not removed, can lead to incorrect measurement results.

8162xx Optical Power Heads

Periodically inspect the optical head's front window for dust and other particles (see *"How to clean instruments with an optical glass plate" on page 101* for cleaning procedures). These can be propelled through the optical head adapter's pinhole while inserting a connector ferrule into the receptacle. Particles on the optical head's front window can significantly impair measurement results.

Safety Precautions

Please follow the following safety rules:

- Do not remove instrument covers when operating.
- Ensure that the instrument is switched off throughout the cleaning procedures.
- Use of controls or adjustments or performance of procedures other than those specified may result in hazardous radiation exposure.
- Make sure that you disable all sources when you are cleaning any optical interfaces.
- Under no circumstances look into the end of an optical device attached to optical outputs when the device is operational. The laser radiation is not visible to the human eye, but it can seriously damage your eyesight.
- To prevent electrical shock, disconnect the instrument from the mains before cleaning. Use a dry cloth, or one slightly dampened with water, to clean the external case parts. Do not attempt to clean internally.
- Do not install parts or perform any unauthorized modification to optical devices.
- Refer servicing only to qualified and authorized personnel.

Why is it important to clean optical devices?

In transmission links optical fiber cores are about 9 μm (0.00035") in diameter. Dust and other particles, however, can range from tenths to hundredths of microns in diameter. Their comparative size means that they can cover a part of the end of a fiber core, and as a result will reduce the performance of your system.

Furthermore, the power density may burn dust into the fiber and cause additional damage (for example, 0 dBm optical power in a single mode fiber causes a power density of approximately 16 million W/m^2). If this happens, measurements become inaccurate and non-repeatable.

Cleaning is, therefore, an essential yet difficult task. Unfortunately, when comparing most published cleaning recommendations, you will discover that they contain several inconsistencies. In this section, we want to suggest ways to help you clean your various optical devices, and thus significantly improve the accuracy and repeatability of your lightwave measurements.

What do I need for proper cleaning?

Some **Standard Cleaning Equipment** is necessary for cleaning your instrument. For certain cleaning procedures, you may also require certain **Additional Cleaning Equipment**.

Standard Cleaning Equipment

Before you can start your cleaning procedure you need the following standard equipment:

- **Dust and shutter caps**
- **Isopropyl alcohol**
- **Cotton swabs**
- **Soft tissues**
- **Pipe cleaner**
- **Compressed air**

Dust and shutter caps

All of Keysight Technologies' lightwave instruments are delivered with either laser shutter caps or dust caps on the lightwave adapter. Any cables come with covers to protect the cable ends from damage or contamination.

We suggest these protective coverings should be kept on the equipment at all times, except when your optical device is in use. Be careful when replacing dust caps after use. Do not press the bottom of the cap onto the fiber too hard, as any dust in the cap can scratch or pollute your fiber surface.

If you need further dust caps, please contact your nearest Keysight Technologies sales office.

Isopropyl alcohol

This solvent is usually available from any local pharmaceutical supplier or chemist's shop.

If you use isopropyl alcohol to clean your optical device, do not immediately dry the surface with compressed air (except when you are cleaning very sensitive optical devices). This is because the dust and the dirt is solved and will leave behind filmy deposits after the alcohol is evaporated. You should therefore first remove the alcohol and the dust with a soft tissue, and then use compressed air to blow away any remaining filaments.

If possible avoid using denatured alcohol containing additives. Instead, apply alcohol used for medical purposes.

Never drink this alcohol, as it may seriously damage your health.

Do not use any other solvents, as some may damage plastic materials and claddings. Acetone, for example, will dissolve the epoxy used with fiber optic connectors. To avoid damage, only use isopropyl alcohol.

Cotton swabs

We recommend that you use swabs such as Q-tips or other cotton swabs normally available from local distributors of medical and hygiene products (for example, a supermarket or a chemist's shop). You may be able to obtain various sizes of swab. If this is the case, select the smallest size for your smallest devices.

Ensure that you use natural cotton swabs. Foam swabs will often leave behind filmy deposits after cleaning.

Use care when cleaning, and avoid pressing too hard onto your optical device with the swab. Too much pressure may scratch the surface, and could cause your device to become misaligned. It is advisable to rub gently over the surface using only a small circular movement.

Swabs should be used straight out of the packet, and never used twice. This is because dust and dirt in the atmosphere, or from a first cleaning, may collect on your swab and scratch the surface of your optical device.

Soft tissues

These are available from most stores and distributors of medical and hygiene products such as supermarkets or chemists' shops.

We recommend that you do not use normal cotton tissues, but multi-layered soft tissues made from non-recycled cellulose. Cellulose tissues are very absorbent and softer. Consequently, they will not scratch the surface of your device over time.

Use care when cleaning, and avoid pressing on your optical device with the tissue. Pressing too hard may lead to scratches on the surface or misalignment of your device. Just rub gently over the surface using a small circular movement.

Use only clean, fresh soft tissues and never apply them twice. Any dust and dirt from the air which collects on your tissue, or which has gathered after initial cleaning, may scratch and pollute your optical device.

Pipe cleaner

Pipe cleaners can be purchased from tobacconists, and come in various shapes and sizes. The most suitable one to select for cleaning purposes has soft bristles, which will not produce scratches.

There are many different kinds of pipe cleaner available from tobacco nists.

The best way to use a pipe cleaner is to push it in and out of the device opening (for example, when cleaning an interface). While you are cleaning, you should slowly rotate the pipe cleaner.

Only use pipe cleaners on connector interfaces or on feed through adapters. Do not use them on optical head adapters, as the center of a pipe cleaner is hard metal and can damage the bottom of the adapter.

Your pipe cleaner should be new when you use it. If it has collected any dust or dirt, this can scratch or contaminate your device.

The tip and center of the pipe cleaner are made of metal. Avoid accidentally pressing these metal parts against the inside of the device, as this can cause scratches.

Compressed air

Compressed air can be purchased from any laboratory supplier.

It is essential that your compressed air is free of dust, water and oil. Only use clean, dry air. If not, this can lead to filmy deposits or scratches on the surface of your connector. This will reduce the performance of your transmission system.

When spraying compressed air, hold the can upright. If the can is held at a slant, propellant could escape and dirty your optical device. First spray into the air, as the initial stream of compressed air could contain some condensation or propellant. Such condensation leaves behind a filmy deposit.

Please be friendly to your environment and use a CFC-free aerosol.

Additional Cleaning Equipment

Some Cleaning Procedures need the following equipment, which is not required to clean each instrument:

- **Microscope with a magnification range about 50X up to 300X**
- **Ultrasonic bath**
- **Warm water and liquid soap**
- **Premoistened cleaning wipes**
- **Polymer film**
- **Infrared Sensor Card**

Microscope with a magnification range about 50X up to 300X

A microscope can be found in most photography stores, or can be obtained through or specialist mail order companies. Special fiber-scopes are available from suppliers of splicing equipment.

Ideally, the light source on your microscope should be very flexible. This will allow you to examine your device closely and from different angles.

A microscope helps you to estimate the type and degree of dirt on your device. You can use a microscope to choose an appropriate cleaning method, and then to examine the results. You can also use your microscope to judge whether your optical device (such as a connector) is severely scratched and is, therefore, causing inaccurate measurements.

Ultrasonic bath

Ultrasonic baths are also available from photography or laboratory suppliers or specialist mail order companies.

An ultrasonic bath will gently remove fat and other stubborn dirt from your optical devices. This helps increase the life span of the optical devices.

Only use isopropyl alcohol in your ultrasonic bath, as other solvents may cause damage.

Warm water and liquid soap

Only use water if you are sure that there is no other way of cleaning your optical device without causing corrosion or damage. Do not use hot water, as this may cause mechanical stress, which can damage your optical device.

Ensure that your liquid soap has no abrasive properties or perfume in it. You should also avoid normal washing up liquid, as it can cover your device in an iridescent film after it has been air dried.

Some lenses and mirrors also have a special coating, which may be sensitive to mechanical stress, or to fat and liquids. For this reason we recommend you do not touch them.

If you are not sure how sensitive your device is to cleaning, please contact the manufacturer or your sales distributor.

Premoistened cleaning wipes

Use pre-moistened cleaning wipes as described in each individual cleaning procedure. Cleaning wipes may be used in every instance where a moistened soft tissue or cotton swab is applied.

Polymer film

Polymer film is available from laboratory suppliers or specialist mail order companies.

Using polymer film is a gentle method of cleaning extremely sensitive devices, such as reference reflectors and mirrors.

Infrared Sensor Card

Infrared sensor cards are available from laboratory suppliers or specialist mail order companies.

With this card you are able to control the shape of laser light emitted. The invisible laser beam is projected onto the sensor card, then becomes visible to the normal eye as a round spot.

Take care never to look into the end of a fiber or any other optical component, when they are in use. This is because the laser can seriously damage your eyes.

Preserving Connectors

Listed below are some hints on how best to keep your connectors in the best possible condition.

Making Connections

Before you make any connection you must ensure that all cables and connectors are clean. If they are dirty, use the appropriate cleaning procedure.

When inserting the ferrule of a patchcord into a connector or an adapter, make sure that the fiber end does not touch the outside of the mating connector or adapter. Otherwise you will rub the fiber end against an unsuitable surface, producing scratches and dirt deposits on the surface of your fiber.

Dust Caps and Shutter Caps

Be careful when replacing dust caps after use. Do not press the bottom of the cap onto the fiber as any dust in the cap can scratch or dirty your fiber surface.

When you have finished cleaning, put the dust cap back on, or close the shutter cap if the equipment is not going to be used immediately.

Always keep the caps on the equipment when it is not in use.

All of Keysight Technologies' lightwave instruments and accessories are shipped with either laser shutter caps or dust caps. If you need additional or replacement dust caps, contact your nearest Keysight Technologies Sales/Service Office.

Immersion Oil and Other Index Matching Compounds

Wherever possible, do not use immersion oil or other index matching compounds with your device. They are liable to impair and dirty the surface of the device. In addition, the characteristics of your device can be changed and your measurement results affected.

Cleaning Instrument Housings

Use a dry and very soft cotton tissue to clean the instrument housing and the keypad. Do not open the instruments as there is a danger of electric shock, or electrostatic discharge. Opening the instrument can cause damage to sensitive components, and in addition your warranty will be voided.

Which Cleaning Procedure should I use ?

Light dirt

If you just want to clean away light dirt, observe the following procedure for all devices:

- Use compressed air to blow away large particles.
- Clean the device with a dry cotton swab.
- Use compressed air to blow away any remaining filament left by the swab.

Heavy dirt

If the above procedure is not enough to clean your instrument, follow one of the procedures below. Please consult *"Cleaning Instructions for this Device" on page 84* for the procedure relevant for this instrument.

If you are unsure of how sensitive your device is to cleaning, please contact the manufacturer or your sales distributor

How to clean connectors

Cleaning connectors is difficult as the core diameter of a single-mode fiber is only about 9 μm. This generally means you cannot see streaks or scratches on the surface. To be certain of the condition of the surface of your connector and to check it after cleaning, you need a microscope.

In the case of scratches, or of dust that has been burnt onto the surface of the connector, you may have no option but to polish the connector. This depends on the degree of dirtiness, or the depth of the scratches. This is a difficult procedure and should only be performed by a skilled person, and as a last resort as it wears out your connector.

WARNING

Never look into the end of an optical cable that is connected to an active source.

To assess the projection of the emitted light beam you can use an infrared sensor card. Hold the card approximately 5 cm from the output of the connector. The invisible emitted light is projected onto the card and becomes visible as a small circular spot.

Preferred Procedure

Use the following procedure on most occasions.

- 1 Clean the connector by rubbing a new, dry cotton swab over the surface using a small circular movement.
- 2 Blow away any remaining lint with compressed air.

Procedure for Stubborn Dirt

Use this procedure when there is greasy dirt on the connector:

- 1 Moisten a new cotton swab with isopropyl alcohol.
- 2 Clean the connector by rubbing the cotton swab over the surface using a small circular movement.
- 3 Take a new, dry soft tissue and remove the alcohol, dissolved sediment and dust, by rubbing gently over the surface using a small circular movement.
- 4 Blow away any remaining lint with compressed air.

An Alternative Procedure

A better, more gentle, but more expensive cleaning procedure is to use an ultrasonic bath with isopropyl alcohol.

- 1 Hold the tip of the connector in the bath for at least three minutes.
- 2 Take a new, dry soft tissue and remove the alcohol, dissolved sediment and dust, by rubbing gently over the surface using a small circular movement.
- 3 Blow away any remaining lint with compressed air.

How to clean connector adapters

CAUTION

Some adapters have an anti-reflection coating on the back to reduce back reflection. This coating is extremely sensitive to solvents and mechanical abrasion. Extra care is needed when cleaning these adapters.

Preferred Procedure

Use the following procedure on most occasions.

- 1 Clean the adapter by rubbing a new, dry cotton swab over the surface using a small circular movement.
- 2 Blow away any remaining lint with compressed air.

Procedure for Stubborn Dirt

Use this procedure when there is greasy dirt on the adapter:

- 1 Moisten a new cotton swab with isopropyl alcohol.
- 2 Clean the adapter by rubbing the cotton swab over the surface using a small circular movement.
- 3 Take a new, dry soft tissue and remove the alcohol, dissolved sediment and dust, by rubbing gently over the surface using a small circular movement.
- 4 Blow away any remaining lint with compressed air.

How to clean connector interfaces

CAUTION

Be careful when using pipe cleaners, as the core and the bristles of the pipe cleaner are hard and can damage the interface.

Do not use pipe cleaners on optical head adapters, as the hard core of normal pipe cleaners can damage the bottom of an adapter.

Preferred Procedure

Use the following procedure on most occasions.

- 1 Clean the interface by pushing and pulling a new, dry pipe cleaner into the opening. Rotate the pipe cleaner slowly as you do this.
- 2 Then clean the interface by rubbing a new, dry cotton swab over the surface using a small circular movement.
- 3 Blow away any remaining lint with compressed air.

Procedure for Stubborn Dirt

Use this procedure when there is greasy dirt on the interface:

- 1 Moisten a new pipe cleaner with isopropyl alcohol.
- 2 Clean the interface by pushing and pulling the pipe cleaner into the opening. Rotate the pipe cleaner slowly as you do this.
- 3 Moisten a new cotton swab with isopropyl alcohol.
- 4 Clean the interface by rubbing the cotton swab over the surface using a small circular movement.
- 5 Using a new, dry pipe cleaner, and a new, dry cotton swab remove the alcohol, any dissolved sediment and dust.
- 6 Blow away any remaining lint with compressed air.

How to clean bare fiber adapters

Bare fiber adapters are difficult to clean. Protect from dust unless they are in use.

CAUTION

Never use any kind of solvent when cleaning a bare fiber adapter as solvents can:

- Damage the foam inside some adapters.
 - Deposit dissolved dirt in the groove, which can then dirty the surface of an inserted fiber.
-

Preferred Procedure

Use the following procedure on most occasions.

- 1 Blow away any dust or dirt with compressed air.

Procedure for Stubborn Dirt

Use this procedure when there is greasy dirt on the adapter:

- 1 Clean the adapter by pushing and pulling a new, dry pipe cleaner into the opening. Rotate the pipe cleaner slowly as you do this.

CAUTION

Be careful when using pipe cleaners, as the core and the bristles of the pipe cleaner are hard and can damage the adapter.

- 2 Clean the adapter by rubbing a new, dry cotton swab over the surface using a small circular movement.
- 3 Blow away any remaining lint with compressed air.

How to clean lenses

Some lenses have special coatings that are sensitive to solvents, grease, liquid and mechanical abrasion. Take extra care when cleaning lenses with these coatings.

Lens assemblies consisting of several lenses are not normally sealed. Therefore, use as little alcohol as possible, as it can get between the lenses and in doing so can change the properties of projection.

Preferred Procedure

Use the following procedure on most occasions.

- 1 Clean the lens by rubbing a new, dry cotton swab over the surface using a small circular movement.
- 2 Blow away any remaining lint with compressed air.

Procedure for Stubborn Dirt

Use this procedure when there is greasy dirt on the lens:

- 1 Moisten a new cotton swab with isopropyl alcohol.

- 2 Clean the lens by rubbing the cotton swab over the surface using a small circular movement.
- 3 Using a new, dry cotton swab remove the alcohol, any dissolved sediment and dust.
- 4 Blow away any remaining lint with compressed air.

How to clean instruments with a fixed connector interface

You should only clean instruments with a fixed connector interface when it is absolutely necessary. This is because it is difficult to remove any used alcohol or filaments from the input of the optical block.

It is important, therefore, to keep dust caps on the equipment at all times, except when your optical device is in use.

If you do discover filaments or particles, the only way to clean a fixed connector interface and the input of the optical block is to use compressed air.

If there are fluids or fat in the connector, please refer the instrument to the skilled personnel of Keysight's service team.

CAUTION

Only use clean, dry compressed air. Make sure that the air is free of dust, water, and oil. If the air that you use is not clean and dry, this can lead to filmy deposits or scratches on the surface of your connector interface. This will degrade the performance of your transmission system.

Never try to open the instrument and clean the optical block by yourself, because it is easy to scratch optical components, and cause them to become misaligned.

How to clean instruments with an optical glass plate

Some instruments, for example, the optical heads from Keysight Technologies have an optical glass plate to protect the sensor. Clean this glass plate in the same way as optical lenses (see *"How to clean lenses" on page 99*).

How to clean instruments with a physical contact interface

Remove any connector interfaces from the optical output of the instrument before you begin the cleaning procedure.

Cleaning interfaces is difficult as the core diameter of a single-mode fiber is only about 9 μm . This generally means you cannot see streaks or scratches on the surface. To be certain of the degree of pollution on the surface of your interface and to check whether it has been removed after cleaning, you need a microscope.

WARNING

Never look into an optical output, because this can seriously damage your eyesight.

To assess the projection of the emitted light beam you can use an infrared sensor card. Hold the card approximately 5 cm from the interface. The invisible emitted light is projected onto the card and becomes visible as a small circular spot.

Preferred Procedure

Use the following procedure on most occasions.

- 1 Clean the interface by rubbing a new, dry cotton swab over the surface using a small circular movement.
- 2 Blow away any remaining lint with compressed air.

Procedure for Stubborn Dirt

Use this procedure when there is greasy dirt on the interface:

- 1 Moisten a new cotton swab with isopropyl alcohol.

- 2 Clean the interface by rubbing the cotton swab over the surface using a small circular movement.
- 3 Take a new, dry soft tissue and remove the alcohol, dissolved sediment and dust, by rubbing gently over the surface using a small circular movement.
- 4 Blow away any remaining lint with compressed air.

How to clean instruments with a recessed lens interface

WARNING

For instruments with a deeply recessed lens interface (for example the Keysight 81634A Power Sensors) do NOT follow this procedure. Alcohol and compressed air could damage your lens even further.

Keep your dust and shutter caps on when your instrument is not in use. This should prevent it from getting too dirty. If you must clean such instruments, please refer the instrument to the skilled personnel of Keysight's service team.

Preferred Procedure

Use the following procedure on most occasions.

- 1 Blow away any dust or dirt with compressed air.
If this is not sufficient, then
- 2 Clean the interface by rubbing a new, dry cotton swab over the surface using a small circular movement.
- 3 Blow away any remaining lint with compressed air.

Procedure for Stubborn Dirt

Use this procedure when there is greasy dirt on the interface, and using the preferred procedure is not sufficient. Using isopropyl alcohol should be your last choice for recessed lens interfaces because of the difficulty of cleaning out any dirt that is washed to the edge of the interface:

- 1 Moisten a new cotton swab with isopropyl alcohol.

- 2 Clean the interface by rubbing the cotton swab over the surface using a small circular movement.
- 3 Take a new, dry soft tissue and remove the alcohol, dissolved sediment and dust, by rubbing gently over the surface using a small circular movement.
- 4 Blow away any remaining lint with compressed air.

How to clean optical devices which are sensitive to mechanical stress and pressure

Some optical devices, such as the Keysight 81000BR Reference Reflector, which has a gold plated surface, are very sensitive to mechanical stress or pressure. Do not use cotton swabs, soft tissues or other mechanical cleaning tools, as these can scratch or destroy the surface.

Preferred Procedure

Use the following procedure on most occasions.

- 1 Blow away any dust or dirt with compressed air.

Procedure for Stubborn Dirt

To clean devices that are extremely sensitive to mechanical stress or pressure you can also use an optical clean polymer film. This procedure is time-consuming, but you avoid scratching or destroying the surface.

- 1 Put the film on the surface and wait at least 30 minutes to make sure that the film has had enough time to dry.
- 2 Remove the film and any dirt with special adhesive tapes.

Alternative Procedure

For these types of optical devices you can often use an ultrasonic bath with isopropyl alcohol. Only use the ultrasonic bath if you are sure that it won't cause any damage any part of the device.

- 1 Put the device into the bath for at least three minutes.
- 2 Blow away any remaining liquid with compressed air.

If there are any streaks or drying stains on the surface, repeat the cleaning procedure.

How to clean metal filters or attenuator gratings

This kind of device is extremely fragile. A misalignment of the grating leads to inaccurate measurements. Never touch the surface of the metal filter or attenuator grating. Be very careful when using or cleaning these devices. Do not use cotton swabs or soft tissues, as there is the danger that you cannot remove the lint and that the device will be destroyed by becoming mechanically distorted.

Preferred Procedure

Use the following procedure on most occasions.

- 1 Use compressed air at a distance and with low pressure to remove any dust or lint.

Procedure for Stubborn Dirt

Do not use an ultrasonic bath as this can damage your device.

Use this procedure when there is greasy dirt on the device:

- 1 Put the optical device into a bath of isopropyl alcohol, and wait at least 10 minutes.
- 2 Remove the fluid using compressed air at some distance and with low pressure. If there are any streaks or drying stains on the surface, repeat the whole cleaning procedure.

Additional Cleaning Information

The following cleaning procedures may be used with other optical equipment:

- [How to clean bare fiber ends](#)
- [How to clean large area lenses and mirrors](#)

How to clean bare fiber ends

Bare fiber ends are often used for splices or, together with other optical components, to create a parallel beam. The end of a fiber can often be scratched. You make a new cleave. To do this:

- 1 Strip off the cladding.
- 2 Take a new soft tissue and moisten it with isopropyl alcohol.
- 3 Carefully clean the bare fiber with this tissue.
- 4 Make your cleave and immediately insert the fiber into your bare fiber adapter in order to protect the surface from dirt.

How to clean large area lenses and mirrors

Some mirrors, as those from a monochromator, are very soft and sensitive. Therefore, never touch them and do not use cleaning tools such as compressed air or polymer film.

Some lenses have special coatings that are sensitive to solvents, grease, liquid and mechanical abrasion. Take extra care when cleaning lenses with these coatings.

Lens assemblies consisting of several lenses are not normally sealed. Therefore, use as little liquid as possible, as it can get between the lenses and in doing so can change the properties of projection.

Preferred Procedure

Use the following procedure on most occasions.

- 1 Blow away any dust or dirt with compressed air.

Procedure for Stubborn Dirt

Use this procedure when there is greasy dirt on the lens:

CAUTION

Only use water if you are sure that there is no other way of cleaning your optical device without causing corrosion or damage.

Only use water if you are sure that there is no other way of cleaning your optical device without causing corrosion or damage. Do not use hot water, as this may cause mechanical stress, which can damage your optical device.

Ensure that your liquid soap has no abrasive properties or perfume in it. You should also avoid normal washing up liquid, as it can cover your device in an iridescent film after it has been air dried.

Some lenses and mirrors also have a special coating, which may be sensitive to mechanical stress, or to fat and liquids. For this reason we recommend you do not touch them.

If you are not sure how sensitive your device is to cleaning, please contact the manufacturer or your sales distributor.

-
- 1 Moisten the lens or the mirror with water.
 - 2 Put a little liquid soap on the surface and gently spread the liquid over the whole area.
 - 3 Wash off the emulsion with water, being careful to remove it all, as any remaining streaks can impair measurement accuracy.
 - 4 Take a new, dry soft tissue and remove the water, by rubbing gently over the surface using a small circular movement.
 - 5 Blow away remaining lint with compressed air.

Alternative Procedure A

To clean lenses that are extremely sensitive to mechanical stress or pressure you can also use an optical clean polymer film. This procedure is time-consuming, but you avoid scratching or destroying the surface.

- 1 Put the film on the surface and wait at least 30 minutes to make sure that the film has had enough time to dry.
- 2 Remove the film and any dirt with special adhesive tapes.

Alternative Procedure B

If your lens is sensitive to water then:

- 1 Moisten the lens or the mirror with isopropyl alcohol.
- 2 Take a new, dry soft tissue and remove the alcohol, dissolved sediment and dust, by rubbing gently over the surface using a small circular movement.
- 3 Blow away remaining lint with compressed air.

Other Cleaning Hints

Selecting the correct cleaning method is an important element in maintaining your equipment and saving you time and money. This Appendix highlights the main cleaning methods, but cannot address every individual circumstance.

This section contain some additional hints which we hope will help you further. For further information, please contact your local Keysight Technologies representative.

Making the connection

Before you make any connection you must ensure that all lightwave cables and connectors are clean. If not, then use the appropriate cleaning methods.

When you insert the ferrule of a patchcord into a connector or an adapter, ensure that the fiber end does not touch the outside of the mating connector or adapter. Otherwise, the fiber end will rub up against something which could scratch it and leave deposits.

Lens cleaning papers

Some special lens cleaning papers are not suitable for cleaning optical devices like connectors, interfaces, lenses, mirrors and so on. To be absolutely certain that a cleaning paper is applicable, please ask the salesperson or the manufacturer.

Immersion oil and other index matching compounds

Do not use immersion oil or other index matching compounds with optical sensors equipped with recessed lenses. They are liable to dirty the detector and impair its performance. They may also alter the property of depiction of your optical device, thus rendering your measurements inaccurate.

Cleaning the housing and the mainframe

When cleaning either the mainframe or the housing of your instrument, only use a dry and very soft cotton tissue on the surfaces and the numeric pad.

Never open the instruments as they can be damaged.
Opening the instruments puts you in danger of receiving an electrical shock from your device, and renders your warranty void.

Index

- A**
-
- Accuracy Test 47
 - Accuracy test
 - Setup 47
 - Analog output 14
 - bandwidth 36
 - Attaching the heat sink 15
 - Averaging time 24
- C**
-
- Calculation sheet
 - linearity test 80
 - Cleaning 84
 - Cleaning connector interfaces 97
 - Cleaning materials 87
 - Connector adapters 22
- G**
-
- Getting started 9
- H**
-
- Heat sink 15
 - mounting 16
- I**
-
- Input power limitations 11
- L**
-
- Linearity 24
 - Linearity Test 50
 - Linearity test
 - calculation sheet 80
 - Setup 50
 - Linewidth 25
- N**
-
- Noise 25
 - Noise Test 59
- O**
-
- Optical Head
 - Functional tests 45
 - Performance tests 39
 - Optical head cleaning 84
 - Optical input 15
- P**
-
- Performance characteristics
 - supplementary 36
- Performance Tests**
- 81623B 67
 - 81624B 70
 - 81626B 73
 - 81628B 77
 - Calculation Sheet for Linearity Measurement (81622B/26B) 81
 - Calculation Sheet for Linearity Measurement (81623B/4B/7B/8B) 80
- R**
-
- Reference conditions 26
 - Relative Uncertainty due to Interference 64
 - Relative Uncertainty due to Polarization 62
 - Return Loss 28
 - Return Loss Test 60
 - Return loss test setup 62
- S**
-
- Safety 10
 - speckle noise 27
 - Spectral width 28
 - Storage 12
- T**
-
- Terms used in specification 24
 - Test sheets 42
 - 81623B 67
 - 81624B 70
 - 81626B 73
 - 81628B 77
 - Total uncertainty 28
- U**
-
- Uncertainty 27
 - polarization 26
 - spectral ripple 27
- W**
-
- Wavelength range 28

This information is subject to change without notice.
© Keysight Technologies 2002, 2015
Edition 6, February 2015



81623-90B12

www.keysight.com