

Series 2400 SourceMeter®

User's Manual

2400S-900-01 Rev. K / September 2011

2400 Series SourceMeter® User's Manual

©2011, Keithley Instruments, Inc.

All rights reserved.

Cleveland, Ohio, U.S.A.

Document Number: 2400S-900-01 Rev. K / September 2011

The following safety precautions should be observed before using this product and any associated instrumentation. Although some instruments and accessories would normally be used with non-hazardous voltages, there are situations where hazardous conditions may be present.

This product is intended for use by qualified personnel who recognize shock hazards and are familiar with the safety precautions required to avoid possible injury. Read and follow all installation, operation, and maintenance information carefully before using the product. Refer to the user documentation for complete product specifications.

If the product is used in a manner not specified, the protection provided by the product warranty may be impaired.

The types of product users are:

Responsible body is the individual or group responsible for the use and maintenance of equipment, for ensuring that the equipment is operated within its specifications and operating limits, and for ensuring that operators are adequately trained.

Operators use the product for its intended function. They must be trained in electrical safety procedures and proper use of the instrument. They must be protected from electric shock and contact with hazardous live circuits.

Maintenance personnel perform routine procedures on the product to keep it operating properly, for example, setting the line voltage or replacing consumable materials. Maintenance procedures are described in the user documentation. The procedures explicitly state if the operator may perform them. Otherwise, they should be performed only by service personnel.

Service personnel are trained to work on live circuits, perform safe installations, and repair products. Only properly trained service personnel may perform installation and service procedures.

Keithley Instruments products are designed for use with electrical signals that are rated Measurement Category I and Measurement Category II, as described in the International Electrotechnical Commission (IEC) Standard IEC 60664. Most measurement, control, and data I/O signals are Measurement Category I and must not be directly connected to mains voltage or to voltage sources with high transient over-voltages. Measurement Category II connections require protection for high transient over-voltages often associated with local AC mains connections. Assume all measurement, control, and data I/O connections are for connection to Category I sources unless otherwise marked or described in the user documentation.

Exercise extreme caution when a shock hazard is present. Lethal voltage may be present on cable connector jacks or test fixtures. The American National Standards Institute (ANSI) states that a shock hazard exists when voltage levels greater than 30V RMS, 42.4V peak, or 60VDC are present. A good safety practice is to expect that hazardous voltage is present in any unknown circuit before measuring.

Operators of this product must be protected from electric shock at all times. The responsible body must ensure that operators are prevented access and/or insulated from every connection point. In some cases, connections must be exposed to potential human contact. Product operators in these circumstances must be trained to protect

themselves from the risk of electric shock. If the circuit is capable of operating at or above 1000V, no conductive part of the circuit may be exposed.

Do not connect switching cards directly to unlimited power circuits. They are intended to be used with impedance-limited sources. NEVER connect switching cards directly to AC mains. When connecting sources to switching cards, install protective devices to limit fault current and voltage to the card.

Before operating an instrument, ensure that the line cord is connected to a properly-grounded power receptacle. Inspect the connecting cables, test leads, and jumpers for possible wear, cracks, or breaks before each use.

When installing equipment where access to the main power cord is restricted, such as rack mounting, a separate main input power disconnect device must be provided in close proximity to the equipment and within easy reach of the operator.

For maximum safety, do not touch the product, test cables, or any other instruments while power is applied to the circuit under test. ALWAYS remove power from the entire test system and discharge any capacitors before: connecting or disconnecting cables or jumpers, installing or removing switching cards, or making internal changes, such as installing or removing jumpers.

Do not touch any object that could provide a current path to the common side of the circuit under test or power line (earth) ground. Always make measurements with dry hands while standing on a dry, insulated surface capable of withstanding the voltage being measured.

The instrument and accessories must be used in accordance with its specifications and operating instructions, or the safety of the equipment may be impaired.

Do not exceed the maximum signal levels of the instruments and accessories, as defined in the specifications and operating information, and as shown on the instrument or test fixture panels, or switching card.

When fuses are used in a product, replace with the same type and rating for continued protection against fire hazard.

Chassis connections must only be used as shield connections for measuring circuits, NOT as safety earth ground connections.

If you are using a test fixture, keep the lid closed while power is applied to the device under test. Safe operation requires the use of a lid interlock.

If a  screw is present, connect it to safety earth ground using the wire recommended in the user documentation.

The  symbol on an instrument means caution, risk of danger. The user should refer to the operating instructions located in the user documentation in all cases where the symbol is marked on the instrument.

The  symbol on an instrument means caution, risk of danger. Use standard safety precautions to avoid personal contact with these voltages.

The  symbol on an instrument shows that the surface may be hot. Avoid personal contact to prevent burns.

The  symbol indicates a connection terminal to the equipment frame.

If this  symbol is on a product, it indicates that mercury is present in the display lamp. Please note that the lamp must be properly disposed of according to federal, state, and local laws.

The **WARNING** heading in the user documentation explains dangers that might result in personal injury or death. Always read the associated information very carefully before performing the indicated procedure.

The **CAUTION** heading in the user documentation explains hazards that could damage the instrument. Such damage may invalidate the warranty.

Instrumentation and accessories shall not be connected to humans.

Before performing any maintenance, disconnect the line cord and all test cables.

To maintain protection from electric shock and fire, replacement components in mains circuits - including the power transformer, test leads, and input jacks - must be purchased from Keithley Instruments. Standard fuses with applicable national safety approvals may be used if the rating and type are the same. Other components that are not safety-related may be purchased from other suppliers as long as they are equivalent to the original component (note that selected parts should be purchased only through Keithley Instruments to maintain accuracy and functionality of the product). If you are unsure about the applicability of a replacement component, call a Keithley Instruments office for information.

To clean an instrument, use a damp cloth or mild, water-based cleaner. Clean the exterior of the instrument only. Do not apply cleaner directly to the instrument or allow liquids to enter or spill on the instrument. Products that consist of a circuit board with no case or chassis (e.g., a data acquisition board for installation into a computer) should never require cleaning if handled according to instructions. If the board becomes contaminated and operation is affected, the board should be returned to the factory for proper cleaning/servicing.

Table of contents

Section	Title	Page
1	Getting Started	
	General information	1-2
	Contact information	1-2
	Manual addenda	1-2
	Safety symbols and terms	1-2
	Inspection	1-3
	Options and accessories	1-3
	Product overview	1-5
	Front and rear panel familiarization	1-6
	Front panel summary	1-6
	Rear panel summary	1-7
	Power-up	1-9
	Line power connection	1-9
	Power-up sequence	1-10
	Line frequency setting	1-11
	Fuse replacement	1-11
	Cooling fan	1-12
	Display	1-13
	Display format	1-13
	EDIT key	1-13
	TOGGLE key	1-13
	Status and error messages	1-14
	Remote display programming	1-14
	Front panel tests	1-14
	Default settings	1-15
	Saving and restoring user setups	1-15
	Factory default settings	1-16
	Remote setups	1-18
	Menus	1-19

	Main menu	1-19
	Rules to navigate menus	1-22
	Editing source and compliance values	1-23
	toggling the source and measure display fields	1-23
	Disabling front panel display	1-24
	Configuration menus	1-24
2	Connections	
	Connection overview	2-2
	Front/rear terminals selection	2-2
	Connections to DUT	2-3
	Sensing methods	2-5
	Guarding methods	2-8
3	Basic Source-Measure Operation	
	WARNING - CAUTION	3-2
	Operation overview	3-4
	Source-measure capabilities	3-4
	Compliance limit	3-6
	Setting the compliance limit	3-8
	Basic circuit configurations	3-9
	Operation considerations	3-10
	Warm-up	3-10
	Auto zero	3-10
	NPLC caching	3-11
	V-source protection	3-12
	Source delay	3-13
	Basic source-measure procedure	3-15
	Front panel source-measure procedure	3-15
	Remote command source-measure procedure	3-18
	Measure only	3-20
	Front panel measure only	3-20
	Remote command measure only	3-21
	Sink operation	3-22
	Battery charging/discharging	3-22
	Sink programming example	3-24
4	Ohms Measurements	
	Ohms configuration menu	4-2
	Ohms measurement methods	4-3
	Selecting ohms measurement method	4-4
	Ohms measurement procedure	4-4
	Ohms sensing	4-6

Sense selection	4-7
Offset-compensated ohms	4-8
Enabling/disabling offset-compensated ohms	4-8
Ohms accuracy calculations	4-9
Ohms source readback	4-11
Ohms source readback selection	4-11
6-wire ohms measurements	4-12
Remote ohms programming	4-13
Remote ohms commands	4-13
Ohms programming example	4-14

5 Pulse Mode Operation (Model 2430 only)

Overview	5-2
Pulse characteristics	5-3
Pulse width	5-4
Output off-time	5-6
Pulse duty cycle	5-6
Fast pulse output	5-7
Pulse jitter	5-8
Pulse energy limitations (10A range)	5-9
Pulse Mode configuration	5-10
Front panel Pulse Mode configuration	5-10
Remote command Pulse Mode configuration	5-11
Pulse-measure considerations	5-12
Measurement speed	5-12
Filter	5-12
Auto range	5-12
Concurrent measurements	5-12
Ohms source readback	5-12
Toggle key	5-13
Offset-compensated ohms	5-13
Source delay	5-13
Trigger delay	5-14
Input triggers	5-14
Output triggers	5-14
Auto output-off	5-14
Output-off state	5-15
Turning source on	5-15
SCPI signal oriented measurement commands	5-15

6 Source-Measure Concepts

Compliance limit	6-2
Types of compliance	6-2
Maximum compliance values	6-3

Compliance examples	6-4
Determining compliance limit	6-4
Overheating protection	6-6
Overheating conditions	6-6
Source-delay-measure cycle	6-7
Sweep waveforms	6-9
Operating boundaries	6-10
Source or sink	6-10
Duty cycle	6-10
I-Source operating boundaries	6-15
V-Source operating boundaries	6-19
Source I measure I and source V measure V	6-22
Basic circuit configurations	6-23
Source I	6-23
Source V	6-24
Measure only (V or I)	6-25
Guard	6-27
Cable guard	6-27
Ohms guard	6-28
Guard sense	6-32
Data flow	6-34
Buffer considerations	6-36

7 Range, Digits, Speed, and Filters

Range and digits	7-2
Range	7-2
Digits	7-5
Remote range and digits programming	7-5
Speed	7-7
Setting speed	7-7
Remote speed programming	7-8
Filters	7-9
Front panel filter control	7-10
Remote filter programming	7-12

8 Relative and Math

Relative	8-2
Front panel rel	8-2
Remote rel programming	8-3
Math operations	8-4
Built-in math functions	8-4
Front panel math operations	8-6
Remote math operations	8-7
User-defined math functions	8-7

9	Data Store	
	Data store overview	9-2
	Front panel data store	9-2
	Storing readings	9-2
	Recalling readings	9-2
	Buffer statistics	9-3
	Timestamp format	9-4
	Buffer considerations	9-5
	Remote command data store	9-5
	Data store commands	9-5
	Data store programming example	9-5
10	Sweep Operation	
	Sweep types	10-2
	Linear staircase sweep	10-2
	Logarithmic staircase sweep	10-4
	Abort on compliance	10-5
	Custom sweep	10-6
	Source memory sweep	10-6
	Configuring and running a sweep	10-12
	Front panel sweep operation	10-12
	Remote sweep operation	10-19
	Pulse Mode sweeps (Model 2430 only)	10-24
	Front panel Pulse Mode sweep procedure	10-25
	Remote Pulse Mode sweep operation	10-26
11	Triggering	
	Front panel trigger operation	11-2
	Front panel trigger model	11-2
	Configuring triggering	11-7
	Remote trigger operation	11-10
	Remote trigger model	11-10
	Remote trigger commands	11-18
	Trigger link	11-19
	Input trigger requirements	11-19
	Output trigger specifications	11-20
	Pulse Mode triggering (Model 2430)	11-20
	Trigger models	11-20
	Invalid trigger settings	11-24
12	Limit Testing	
	Types of limits	12-2
	Pass/fail information	12-2

Data flow	12-3
Limit 1 test (compliance)	12-3
Limit 2, limit 3, and limit 5-12 tests	12-3
Limit 4	12-3
Limit test modes	12-3
Binning	12-4
Operation overview	12-4
Grading mode	12-4
Sorting mode	12-7
Binning systems	12-10
Handler interface	12-10
Handler types	12-12
Basic binning systems	12-13
Digital output clear pattern	12-14
Configuring and performing limit tests	12-16
Configuring limit tests	12-16
Performing front panel limit tests	12-19
Remote limit testing	12-20
Limit commands	12-20

13 Digital I/O Port, Output Enable, & Output Configuration

Digital I/O port	13-2
Port configuration	13-2
Digital output configuration	13-3
Controlling digital output lines	13-4
Output enable line	13-6
Front panel output configuration	13-7
Configure OUTPUT menu	13-8
Output-off states	13-9
Output-off states and inductive loads	13-11
Remote output configuration	13-12
Output configuration commands	13-12

14 Remote Operations

Differences: remote vs. local operation	14-2
Operation enhancements (remote operation)	14-2
Local-to-remote transition	14-2
Remote-to-local transition	14-3
Selecting an interface	14-3
GPIB operation	14-4
GPIB standards	14-4
GPIB connections	14-4
Primary address	14-4
General bus commands	14-5

Front panel GPIB operation	14-5
Error and status messages	14-5
GPIB status indicators	14-5
LOCAL key	14-6
Programming syntax	14-6
Command words	14-6
Query commands	14-9
Case sensitivity	14-9
Long-form and short-form versions	14-9
Short-form rules	14-10
Response messages	14-12
Message exchange protocol	14-13
RS-232 interface operation	14-13
Sending and receiving data	14-13
Baud rate	14-14
Data bits and parity	14-14
Terminator	14-14
Flow control (signal handshaking)	14-15
RS-232 connections	14-15
Error messages	14-17

15 Status Structure

Overview	15-2
Status byte and SRQ	15-2
Status register sets	15-2
Queues	15-2
Clearing registers and queues	15-4
Programming and reading registers	15-5
Programming enable registers	15-5
Reading registers	15-6
Status byte and service request (SRQ)	15-7
Status byte register	15-8
Service request enable register	15-9
Serial polling and SRQ	15-9
Status byte and service request commands	15-10
Status register sets	15-11
Register bit descriptions	15-11
Condition registers	15-16
Event registers	15-16
Event enable registers	15-17
Queues	15-18
Output queue	15-18
Error queue	15-19

16 Common Commands

Command summary	16-2
Command reference	16-3
*IDN? — identification query	16-3
*OPC — operation complete	16-3
*OPC? — operation complete query	16-3
*SAV <NRf> — save	16-3
*RCL <NRf> — recall	16-3
**RST — reset	16-4
*TRG — trigger	16-4
**TST? — self-test query	16-4
*WAI — wait-to-continue	16-5

17 SCPI Signal Oriented Measurement Commands

Command summary	17-2
Configuring measurement function	17-2
:CONFigure:<function>	17-2
Acquiring readings	17-3
:FETCh?	17-3
[:SENSe[1]]:DATA[:LATest]?	17-4
:READ?	17-4
:MEASure[:<function>]?	17-5

18 SCPI Command Reference

Reference tables	18-2
Calculate subsystems	18-26
CALCulate[1]	18-26
Select (create) math expression name	18-26
Assign unit suffix	18-28
Define math expression	18-29
Enable and read math expression result	18-32
CALCulate2	18-33
Select input path	18-33
Null feed reading	18-34
Read CALC2	18-34
Configure and control limit tests	18-35
Composite testing	18-39
Clear test results	18-42
CALCulate3	18-43
Select statistic	18-43
Acquire statistic	18-43
DISPlay subsystem	18-44
Control display	18-44

Read display	18-46
Define :TEXT messages	18-46
FORMat subsystem	18-47
Data format	18-47
Data elements	18-49
CALC data elements	18-53
Byte order	18-54
Status register format	18-54
OUTPut subsystem	18-55
Turn source on or off	18-55
Output enable line	18-56
Output-off states	18-56
ROUTE subsystem	18-57
Select input jacks	18-57
SENSe1 subsystem	18-58
Select measurement functions	18-58
Select measurement range	18-62
Select auto range	18-65
Current range holdoff	18-66
Set compliance parameters	18-67
Set measurement speed	18-69
Configure and control filter	18-70
SOURce subsystem	18-71
SOURce[1]	18-71
Control source output-off	18-71
Select function modes	18-72
Select sourcing mode	18-73
Select range	18-74
Set amplitude for fixed source	18-77
Set voltage limit	18-79
Set delay	18-82
Configure voltage and current sweeps	18-83
Abort on compliance	18-90
Configure list	18-91
Configure memory sweep	18-93
Set scaling factor	18-95
Soak time	18-96
Pulse Mode delays (Model 2430 only)	18-97
SOURce2	18-98
Setting digital output	18-98
Clearing digital output	18-99
STATus subsystem	18-101
Read event registers	18-101
Program event enable registers	18-101
Read condition registers	18-101

Select default conditions	18-102
Error queue	18-102
SYSTem subsystem	18-103
Default conditions	18-103
Control remote sensing	18-104
Select guard mode	18-105
Initialize memory	18-106
Control beeper	18-106
Control auto zero	18-107
Control NPLC caching	18-107
Select power line frequency setting	18-108
Error queue	18-109
Simulate key presses	18-110
Read version of SCPI standard	18-112
RS-232 interface	18-112
Query timestamp	18-112
Reset timestamp	18-113
Auto reset timestamp	18-113
Auto range change mode	18-113
TRACe subsystem	18-114
Read and clear buffer	18-114
Configure and control buffer	18-114
Select timestamp format	18-116
TRIGger subsystem	18-116
Clear input triggers	18-116
Initiate source/measure cycle	18-117
Abort source/measure cycle	18-117
Program trigger model	18-117
Accuracy calculations	A-2
Measure accuracy	A-2
Source accuracy	A-2
Source-Delay-Measure (SDM) cycle timing	A-3
Definitions	A-3
Timing diagrams	A-4
Introduction	B-2
Status and error messages	B-2
Eliminating common SCPI errors	B-8
Introduction	C-2
FETCh?	C-3
CALCulate[1]:DATA?	C-4
CALCulate2:DATA?	C-4
TRACe:DATA?	C-4
CALCulate3:DATA?	C-4
Introduction	D-2
Bus description	D-3

Bus lines	D-5
Data lines	D-5
Bus management lines	D-5
Handshake lines	D-5
Bus commands	D-6
Addressed multiline commands	D-8
Address commands	D-8
Unaddress commands	D-8
Common commands	D-8
SCPI commands	D-8
Command codes	D-9
IEEE command groups	D-11
Interface function codes	D-12
Introduction	E-2
Introduction	F-2
Overview	F-2
Description	F-2
Operation	F-3
DUT connections	F-3
Contact check threshold resistances	F-4
Contact check failure indications	F-5
Auto and manual ohms	F-5
Trigger model operation	F-6
Sweep and binning considerations	F-6
Sweep limitations	F-6
Limit test sequence	F-7
Binning failure indications (grading mode)	F-10
Front panel contact check operation	F-11
Menu selections	F-11
Using contact check	F-12
Remote contact check operation	F-14
Contact check remote commands	F-14
Contact check programming example	F-15
Contact check command reference	F-17
Configure and control contact check	F-17
Configure and control contact check limit test	F-17
Configure and control contact check event detection	F-19
Contact check defaults	F-20
Introduction	G-2
Selecting the 488.1 protocol	G-2
Protocol differences	G-3
Message exchange protocol (MEP)	G-3
Using SCPI-based programs	G-4
NRFD hold-off	G-4
NDAC hold-off	G-4

Trigger-on-talk	G-5
Message available	G-5
General operation notes	G-5

1 Getting Started

- **General information** — Covers general information that includes contact information, safety symbols and terms, inspection, and available options and accessories.
- **Product overview** — Summarizes the features of the SourceMeter.
- **Front and rear panel familiarization** — Summarizes the controls and connectors of the instrument.
- **Power-up** — Covers line power connection, line voltage settings, fuse replacement, and the power-up sequence.
- **Cooling fan** — Covers the cooling fan in the Models 2410, 2420, 2425, 2430, and 2440.
- **Display** — Provides information about the SourceMeter display.
- **Default settings** — Covers factory default setups and saving and recalling user setups.
- **Menus** — Covers the main and configuration menus as well as rules to navigate menus.

General information

Contact information

Worldwide phone numbers are listed at the front of this manual. If you have any questions, please contact your local Keithley representative or call one of our Application Engineers at 1-800-348-3735 (U.S. and Canada only).

Manual addenda

Any improvements or changes concerning the instrument or manual will be explained in an addendum included with the manual. Be sure to note these changes and incorporate them into the manual.

Safety symbols and terms

The following symbols and terms may be found on the instrument or used in this manual.

The  symbol on an instrument indicates that the user should refer to the operating instructions located in the manual.

The  symbol on the instrument shows that high voltage may be present on the terminal(s). Use standard safety precautions to avoid personal contact with these voltages.

The **WARNING** heading used in this manual explains dangers that might result in personal injury or death. Always read the associated information very carefully before performing the indicated procedure.

The **CAUTION** heading used in this manual explains hazards that could damage the instrument. Such damage may invalidate the warranty.

Inspection

The SourceMeter was carefully inspected electrically and mechanically before shipment. After unpacking all items from the shipping carton, check for any obvious signs of physical damage that may have occurred during transit. (There may be a protective film over the display lens, which can be removed.) Report any damage to the shipping agent immediately. Save the original packing carton for possible future shipment. The following items are included with every SourceMeter order:

- SourceMeter with line cord.
- Test leads (Model 8605 for 2400, 2400-C; Model 1754 for all other series 2400 units).
- Accessories as ordered.
- Certificate of calibration.
- User's Manual.
- Service Manual.
- Support Software Disk including TestPoint instrument library for GPIB and LabVIEW for Windows driver.
- Manual addenda containing any improvements or changes to the instrument or manual.

If an additional manual is required, order the appropriate manual package (for example, 2400-901-00). The manual packages include a manual and any pertinent addenda.

Options and accessories

The following options and accessories are available from Keithley for use with the SourceMeter.

Cables and adapters

Model 2499-DIGIO adapter — Lets you expand the Digital I/O port to 16 bits instead of 4 bits.

Models 7007-1 and 7007-2 shielded GPIB cables — Connect the SourceMeter to the GPIB bus using shielded cables and connectors to reduce electromagnetic interference (EMI). The Model 7007-1 is 1m long; the Model 7007-2 is 2m long.

Models 8501-1 and 8501-2 trigger link cables — Connect the SourceMeter to other instruments with Trigger Link connectors (e.g., Model 7001 Switch System). The Model 8501-1 is 1m long; the Model 8501-2 is 2m long.

Model 8502 trigger link adapter — Lets you connect any of the six Trigger Link lines of the SourceMeter to instruments that use the standard BNC trigger connectors.

Model 8503 DIN to BNC trigger cable — Lets you connect Trigger Link lines one (Voltmeter Complete) and two (External Trigger) of the SourceMeter to instruments that use BNC trigger connectors. The Model 8503 is 1m long.

Model 8505 trigger link cable — The Model 8505 is a male to dual-female trigger link cable.

Rack mount kits

Model 4288-1 single fixed rack mount kit — Mounts a single SourceMeter in a standard 19-inch rack.

Model 4288-2 side-by-side rack mount kit — Mounts two instruments (Models 182, 428, 486, 487, 2000, 2001, 2002, 2010, 2015, 2400, 2410, 2420, 2425, 2430, 2440, 6430, 6517, 7001) side-by-side in a standard 19-inch rack.

Model 4288-3 side-by-side rack mount kit — Mounts a SourceMeter and a Model 199 side-by-side in a standard 19-inch rack.

Model 4288-4 side-by-side rack mount kit — Mounts a SourceMeter and a 5.25-inch instrument (Models 195A, 196, 220, 224, 230, 263, 595, 614, 617, 705, 740, 775, etc.) side-by-side in a standard 19-inch rack.

Model 4288-5 dual fixed rack mounting kit — Mounts a SourceMeter and another 3H-inch high instrument (Model 182, 428, 486, 487, 2000, 2010, 2400, 2410, 2420, 2425, 2430, 6430, or 7001), side-by-side in a standard 19-inch rack.

Carrying case

Model 1050 padded carrying case — A carrying case for a SourceMeter. Includes handles and a shoulder strap.

Product overview

The SourceMeter combines a precise, low-noise, highly stable DC power supply with a low-noise, highly repeatable, high-impedance multimeter. It has 0.012% basic accuracy with 5½digit resolution. At 5½digits, the SourceMeter delivers 520 readings/second over the IEEE-488 bus. At 4½digits, it can read up to 2000 readings/second into its internal buffer. See [Appendix A](#) for specifications.

Some additional capabilities of the SourceMeter include:

- Concurrent measurements of all three functions over the remote interface.
- Source-measure sweep capabilities (linear and logarithmic staircase sweeps, source sweep list of up to 2500 points, memory sweep of up to 100 instrument setups).
- 6-wire Ω measurement with programmable I-source or V-source with V or I clamp.
- 4-quadrant source and sink operation.
- Up to 12 stages of limit testing with a built-in comparator for pass/fail testing.
- Digital I/O for stand-alone binning operations or interface to component handler.
- Programming language and remote interfaces — The SourceMeter uses the SCPI programming language and two remote interface ports (IEEE-488/GPIB and RS-232C).
- Trigger-Link interface to Keithley Series 7000 switching hardware.
- Math expressions — Five built-in, up to five user-defined (bus only).
- Reading and setup storage — Up to 2500 readings and seven setups (five user defaults, factory default, *RST default) can be stored and recalled.
- Closed-cover calibration — The instrument can be calibrated either from the front panel or remote interface.

Front and rear panel familiarization

NOTE The SourceMeter models covered in this manual are very similar in appearance. Therefore, to avoid redundancy, a generic Model 2400 is used for illustration purposes.

Front panel summary

The front panel of the SourceMeter is shown in [Figure 1-1](#). The following abbreviated information should be reviewed before operating the instrument.

Figure 1-1
SourceMeter front panel



Measurement (MEAS) function keys:

V	Measure volts.
I	Measure amps.
Ω	Measure ohms.
FCTN	Perform math functions.

SOURCE function keys:

V	Source voltage (V-Source).
I	Source current (I-Source).
Δ and ∇	Increase/decrease source or compliance value.

Operation keys:

EDIT	Select source or compliance reading for editing.
TOGGLE	Toggle display positions of source and measure readings, or display V and I measurements.
LOCAL	Cancel remote operation.
REL	Enable/disable relative reading on present function.
FILTER	Display digital filter status for present function and toggle filter on/off.
LIMIT	Perform configured limit tests.
TRIG	Trigger a measurement from the front panel.

SWEEP	Start configured sweep.
left/right arrows	Move through parameter values or selections within functions and operations.
DIGITS	Change number of digits of display resolution.
SPEED	Change measurement speed by selecting accuracy or specifying NPLC.
STORE	Set buffer size and enable reading storage.
RECALL	Display stored readings and timestamp.
CONFIG	Press CONFIG and then appropriate key to configure function or operation.
MENU	Access and configure Main Menu selections. When entering numeric data, use to clear reading to minimum absolute value.
EXIT	Cancels selection. Use to back out of menu structures.
ENTER	Accepts selection.

RANGE keys:

Δ	Moves to next higher range, increments digit, moves to next selection.
∇	Moves to next lower range, decrements digit, moves to previous selection.
AUTO	Enables or disables measurement auto range.

Annunciators:

EDIT	Instrument in edit mode.
ERR	Questionable reading, invalid cal step.
REM	Instrument in GPIB remote mode.
TALK	Instrument addressed to talk over GPIB.
LSTN	Instrument addressed to listen over GPIB.
SRQ	Service request over GPIB.
REAR	Rear input/output connectors selected.
REL	Relative measure reading displayed.
FILT	Digital filter enabled.
MATH	Math function enabled.
4W	Remote sensing enabled.
AUTO	Autoranging enabled.
ARM	Source-measure operations being performed.
TRIG	External trigger source selected.
*	Reading being stored.

Input/output connectors:

INPUT/OUTPUT HI and LOUse to source-measure volts, amps, and ohms.
4-WIRE SENSE HI and LOUse for 4-wire remote sensing.

Input/output controls:

ON/OFF	Turns the source on or off.
FRONT/REAR	Selects front or rear panel input/output connections.

Handle:

Pull out and rotate to desired position.

Rear panel summary

The rear panel of the Model 2400 SourceMeter is shown in [Figure 1-2](#). (The Models 2410, 2420, 2425, 2430, and 2440 are similar.) The following abbreviated information should be reviewed before operating the instrument.

NOTE Models 2420, 2425, 2430, and 2440 are not UL listed.

Figure 1-2
SourceMeter rear panel

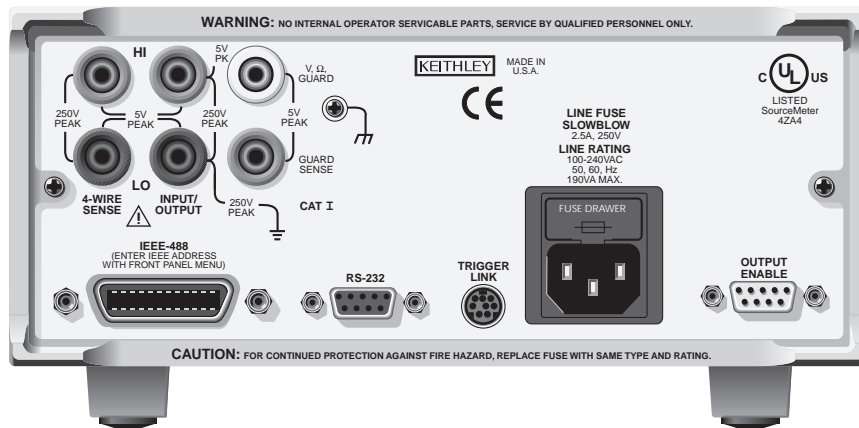

Input/output connectors:

- INPUT/OUTPUT HI and LO Use to source-measure volts, amps, and ohms.
- 4-WIRE SENSE HI and LO Use for 4-wire remote sensing.
- V, Ω GUARD Driven guard for guarded measurements.
- GUARD SENSE Use to correct for IR drops in Guard Output lead.
- Earth (chassis) ground screw.

WARNING INPUT/OUTPUT LO is not internally connected to the chassis and cannot be allowed to float more than the values shown in [Figure 2-1 in Section 2](#) above chassis ground.

Output enable and digital input/output port:

- OUTPUT ENABLE Connector for digital output lines, output enable, and component handler signals.

Power module:

- Contains the AC line receptacle and the power line fuse.

Trigger link connector:

- TRIGGER LINK 8-pin micro-DIN connector for sending and receiving trigger pulses. Use a trigger link cable or adapter, such as Models 8501-1, 8501-2, 8502, 8504.

RS-232 connector:

- RS-232 Connector for RS-232 remote operation. Use a straight through (not null modem) DB-9 cable.

GPIB connector:

- IEEE-488 INTERFACE Connector for GPIB remote operation. Use a shielded cable (Model 7007-1 or 7007-2).

Power-up

During the power-up, voltage spikes may appear on the terminals of the SourceMeter. These voltage spikes could be at hazardous levels (42.4V peak) and could damage sensitive DUTs. Never touch external circuitry or the test leads when powering up the SourceMeter. It is good practice to always disconnect DUTs from the SourceMeter before powering up the unit.

To prevent electric shock, test connections must be configured such that the user cannot come in contact with conductors or any DUT that is in contact with the conductors. Safe installation requires proper shields, barriers, and grounding to prevent contact with conductors. Operator protection and safety are the responsibility of the person installing the product.

When handling the SourceMeter, NEVER touch the heat sink located on the left side of the case. This heat sink could be hot enough to cause burns.

Line power connection

The SourceMeter operates from a line voltage in the range of 100 to 240V at a frequency of 50 or 60Hz. Line voltage and line frequency are automatically sensed. Therefore, there are no switches to set. Check to be sure the operating voltage in your area is compatible.

CAUTION Operating the instrument on an incorrect line voltage may cause damage, possibly voiding the warranty.

Perform the following steps to connect the SourceMeter to line power and turn it on:

1. Before plugging in the power cord, make sure the front panel power switch is in the off (0) position.
2. Connect the female end of the supplied power cord to the AC receptacle on the rear panel.

The power cord supplied with the SourceMeter contains a separate ground for use with grounded outlets. When proper connections are made, instrument chassis is connected to power line ground through the ground wire in the power cord. Failure to use a grounded outlet may result in personal injury or death due to electric shock.

3. Turn on the instrument by pressing the front panel power switch to the on (1) position.

Power-up sequence

On power-up, the SourceMeter performs self-tests on its EPROM and RAM and momentarily lights all segments and annunciators. If a failure is detected, the instrument momentarily displays an error message, and the ERR annunciator turns on (error messages are listed in [Appendix B](#)).

NOTE For the Model 2430, there is an internal bank of capacitors that need to charge. While charging, the message “Charging capacitor bank, please wait” message will be displayed for approximately 10 seconds.

If a problem develops while the instrument is under warranty, return it to Keithley Instruments, Inc., for repair.

If the instrument passes the self-tests, the model number and the firmware revision levels are displayed. For example:

REV A01 A02

where: A01 is the main board ROM revision.

A02 is the display board ROM revision.

Also displayed is the line frequency. (If the wrong frequency is displayed, it can be set manually as covered below). The communication interface status is briefly displayed. If the IEEE-488 bus is the presently selected interface, the identification message will include the primary address. For example, if the primary address is 24 (factory default), the “IEEE Addr=24” message is displayed. If the RS-232 interface is selected, the “RS-232” message is displayed.

After the power-up sequence, the instrument goes to its normal display state with the output off (OUTPUT indicator light off). With the output off, the “OFF” message is displayed, and dashes replace the reading.

Line frequency setting

At the factory, the SourceMeter is configured to sense the power line frequency and automatically select the frequency setting. If, however, the line power source is noisy, the SourceMeter may select the wrong setting on power-up. If this situation occurs, noisy measurement readings will result, and accuracy may be affected. You can manually set the line frequency from the front panel MENU/AD-CTRL/LINE-FREQ selection, or SYST:LFR by remote.

Fuse replacement

A rear panel fuse protects the power line input of the SourceMeter. If the line fuse needs to be replaced, perform the following steps:

CAUTION For continued protection against fire or instrument damage, replace the fuse only with the type and rating listed. If the instrument repeatedly blows fuses, locate and correct the cause of the problem before replacing the fuse.

1. The fuse is located in a drawer above the AC receptacle (Figure 1-2). At the bottom of the fuse drawer is a small tab. At this location, use a small bladed screwdriver to pry the fuse drawer open.
2. Slide the fuse drawer out to gain access to the fuse. Note that the fuse drawer does not pull all the way out of the power module.
3. Snap the fuse out of the drawer and replace it with the same type (Appendix Table 1-1).
4. Push the fuse drawer back into the power module.

Table 1-1
Power line fuse

SourceMeter	Fuse description	Keithley part number
2400, 2400-LV, 2401, and 2410	250V, 2.5A, 5 × 20mm	FU-72
2420, 2425, 2430, and 2440	250V, 3.15A, 5 × 20mm	FU-106-3.15

Cooling fan

The Models 2410, 2420, 2425, 2430, and 2440 use a cooling fan to help keep them from overheating. The Models 2400 and 2401 do not have a cooling fan. In either case (fan or no fan), proper ventilation must be maintained to prevent overheating. Refer to the **“WARNING - CAUTION”** located at the beginning of [Section 3](#) for details on maintaining proper ventilation.

Model 2410 — Uses a constant-speed fan that runs continuously while the power is on.

Models 2420, 2425, 2430, and 2440 — Uses a 3-speed fan. With the OUTPUT ON, the fan speed setting is determined by the present current range (source or measure).

2420, 2425, 2430, and 2440 range	Fan speed
10uA, 100uA, 1mA 10mA, 100mA 1A, 3A, 3A/10A (2430) 1A, 5A (2440)	Low (50%) Medium (75%) High (100%) High (100%)

When the OUTPUT is turned OFF, the fan will either run at the low speed or stay at the speed it was at when the output was on (current range dependent). This speed option is set from the FAN selection of the GENERAL MENU. (See **“Main menu”** in this section.)

NOTE *If the Model 2420, 2425, 2430, or 2440 overheats, the output will trip and the cooling fan will run at high speed (regardless of the speed option setting). See [Section 6](#), “Overheating protection,” for details.*

Display

Display format

The SourceMeter display is used primarily to program source and compliance values and display measured readings. Annunciators, which are located along the top of the reading/message display, indicate various states of operation, as covered previously in [“Front panel summary.”](#)

On power-up, the top (primary) display is used for measurements when the output is on (with the output off, “OFF” is displayed). The bottom-left display is used for the programmed source value (Vsrc or Isrc), and the bottom-right display is used for the programmed compliance (Cmpl) limit.

Reading information can be displayed using either engineering units or scientific notation in either fixed- or floating-point format. Use the GENERAL/NUMBERS selection of the main MENU to select the display format, as discussed in [“Menus”](#) later in this section.

Engineering units example: 1.23456 μ A

Scientific notation example: 1.23456e -6

NOTE The display may be disabled for faster operation. See [“Disabling front panel display,” page 1-24.](#)

EDIT key

The SourceMeter must be in the edit mode to set source and compliance values. The edit mode is selected by pressing the EDIT key (EDIT annunciator on). The editing cursor (flashing digit) appears for the source or compliance reading. If a value is not edited within six seconds, the edit mode is cancelled. While in the edit mode, the EDIT key toggles between the source value and compliance value. See [Section 3](#) for details on setting source and compliance values.

TOGGLE key

NOTE For the Model 2430 Pulse Mode, the TOGGLE key is disabled.

With the output on, the TOGGLE key manipulates readings on the top display and on the bottom-left display. It has no effect on the compliance reading (Cmpl), which is located on the bottom right. Each press of the TOGGLE key sequences through the display options.

With the voltage (V) or current (I) measurement function selected, the TOGGLE key lets you display both the current and voltage measurements at the same time. It also allows you to toggle display positions of the source and measure readings.

With the ohms (Ω) measurement function selected, the ohms measurement is always displayed on the top display. The TOGGLE key lets you display either the programmed source value, the current measurement, or the voltage measurement on the bottom-left display.

The TOGGLE key is also used to display statistical data on readings stored in the data store. This function is performed from the data store RECALL mode.

NOTE If FCTN, REL, or Limits is enabled, the TOGGLE key is disabled.

Status and error messages

Status and error messages are displayed momentarily. During SourceMeter operation and programming, you will encounter a number of front panel messages. Typical messages are either status or error in nature and are listed in [Appendix B](#).

Remote display programming

The display can also be controlled by various SCPI :DISPlay subsystem commands. See [Section 18, "DISPlay subsystem,"](#) for more information on using these commands. See also ["Disabling front panel display," page 1-24](#).

Front panel tests

Use the TEST/FRONT-PANEL-TESTS selection of the main MENU to test various aspects of the front panel. See ["Menus," page 1-19](#), for more information.

Default settings

By using appropriate menu selections, you can save and recall various instrument setups, define the power-on configuration, or restore factory defaults as outlined below.

Saving and restoring user setups

You can save and restore up to five of your own user setups as covered below. This feature provides a convenient way to save specific instrument configurations and then recall them as needed. Note that you can also set up the SourceMeter to restore a specific user setup at power-on. See [“Power-on configuration,” page 1-15](#).

NOTE There are two types of setups. Instrument configuration (user) setups (covered here) and source memory sweep setups ([Section 10](#)).

Saving setups

1. Select the various instrument operating modes you wish to save.
2. Press the MENU key, select SAVESETUP, then press ENTER.
3. From the SAVESETUP menu, select GLOBAL, then press ENTER.
4. From the GLOBAL SETUP MENU, select SAVE, then press ENTER.
5. Select the setup position (0-4) to save, then press ENTER to complete the process.

Restoring setups

1. Press the MENU key, select SAVESETUP, then press ENTER.
2. From the SAVESETUP menu, select GLOBAL, then press ENTER.
3. From the GLOBAL SETUP MENU, select RESTORE, then press ENTER.
4. Select the setup position (0-4) to restore, then press ENTER to complete the process.

Power-on configuration

You can also define which of the stored setups (factory default or user) the instrument assumes as the power-on configuration as follows:

1. Press the MENU key, select SAVESETUP, then press ENTER.
2. From the SAVESETUP menu, select GLOBAL, then press ENTER.
3. From the GLOBAL SETUP MENU, select POWERON, then press ENTER.
4. From the SET POWER-ON DEFAULT menu, choose the power-on configuration: BENCH or GPIB (see below), or USER-SETUP-NUMBER.

5. If you chose to use a user setup as the power-on configuration, select the user setup number, then press ENTER.

Factory default settings

As summarized in [Table 1-2](#), there are two sets of factory defaults, BENCH (front panel) and GPIB (remote). You can restore either of these default conditions as follows:

1. Press the MENU key, select SAVESETUP, then press ENTER.
2. From the SAVESETUP menu, select GLOBAL, then press ENTER.
3. From the GLOBAL SETUP MENU, select RESET, then press ENTER.
4. Select BENCH or GPIB defaults as desired, then press ENTER to complete the process.

Table 1-2
Factory default settings

Setting	BENCH or GPIB default
A/D Controls:	
Auto-zero	On
Line frequency	No effect
Beeper	On
Contact check mode	Disabled**
Contact check threshold resistance	50ohms**
Contact check event detection	Disabled**
Contact check timeout	0**
Data Store	No effect
Digital output	HI, HI, HI, HI
Digits	5
Fan (2420, 2425, 2430, and 2440)	Output on
FCTN	Power (off)
Filter:	Off
Averaging type	Repeat
Count	10
GPIB address	No effect
Guard	Cable
Limit tests:	
DigOut:	
Size	4-bit
Mode:	Grading
Binning control	Immediate
Auto clear:	Disabled
Delay	0.00001 sec

Table 1-2 (cont.)

Factory default settings

Clear pattern	15**
H/W limits:	
Control	Disabled
Fail mode:	In compliance
Cmpl pattern	15
S/W limits:	
Lim 2, 3, 5-12:	
Control	Disabled
Low limit:	-1.0
Low pattern	15
High limit:	+1.0
High pattern	15
Pass (all tests):	
Pass pattern	15
Source memory location	Next
EOT mode	EOT
Numbers	No effect
Ohms source mode	Auto
Offset compensated ohms	Off
Output	Off
Output enable	Disabled
Off state	Normal*
Auto-off	Disabled
Power-on default	No effect
Pulse Mode (2430 only)	
Pulse delay	0.0s
Pulse width	0.20ms
Ranging (measure):	
Auto range	Enabled
Rel	Off
Value	0.0
RS-232	No effect
Sense mode	2-wire
Source delay	1ms
Auto-delay	Enabled
Source shape (2430 only):	DC mode
Speed	Normal (1 PLC)
Sweep	Linear staircase
Start	0V or 0A
Stop	0V or 0A
Step	0V or 0A
Sweep count	1
Sweep Pts	2500
Source ranging	Best fixed
Abort on compliance	Off

Table 1-2 (cont.)
Factory default settings

Voltage protection	NONE
Triggered source:	
Control	Disabled
Scale factor	+1.0
Triggering:	
Arm layer:	
Event	Immediate
Count	1
Output trigger	Line #2, Off
Trigger layer:	
Event	Immediate
Count	1
Output triggers	Line #2, All off
Delay	0.0 sec

* Model 2410 default off state is guard.

** For instruments with contact check option (denoted by a -C in model number).

Remote setups

You can also save and recall setups via remote using the following SCPI commands:

- Save and recall user setups using *SAV and *RCL ([Section 16](#)).
- Restore GPIB defaults using *RST ([Section 16](#)).
- Restore bench defaults using :SYSTem:PRESet ([Section 18](#)).
- Save the power-on configuration using :SYSTem:POSetup ([Section 18](#)).

Menus

The following paragraphs discuss the main menu, configuration menus, and rules to navigate menus.

Main menu

Use the MENU key to access the Main Menu to select, configure, and/or perform various instrument operations. The overall Main Menu structure is summarized in [Table 1-3](#). Use the [“Rules to navigate menus”](#) to check and/or change Main Menu options.

Table 1-3
Main menu

Menu item ¹	Description	Parameters
SAVESETUP	Configure setup conditions.	
GLOBAL	Control instrument settings.	
SAVE	Save present SourceMeter setup to memory location.	0 to 4
RESTORE	Return the SourceMeter to setup saved in memory.	0 to 4
POWERON	Select the power-on default setup.	
BENCH	Powers-on to BENCH defaults.	See Table 1-2
GPIB	Powers-on to GPIB defaults.	See Table 1-2
USER SETUP NUMBER	Powers-on to user setup.	0 to 4
RESET	Returns unit to BENCH or GPIB defaults.	See Table 1-2
SOURCE MEMORY	Control memory sweep source setup configurations.	
SAVE	Save present setup configuration to memory location.	1 to 100
RESTORE	Return to configuration saved in memory location.	1 to 100
COMMUNICATION²	Select and configure remote interface.	
GPIB	Select GPIB (IEEE-488 Bus), set primary address and GPIB protocol.	0 to 30 (Default: 24)
RS-232	Select the RS-232 interface, set parameters.	
BAUD	Select baud rate.	57600, 38400, 19200, 9600, 4800, 2400, 1200, 600, 300
BITS	Select number of data bits.	7 or 8
PARITY	Select parity.	NONE, ODD, EVEN
TERMINATOR	Select terminator.	CR, CR+LF, LF, or LF+CR
FLOW CTRL	Select flow control.	NONE or XON/XOFF
CAL³	Calibrate SourceMeter. (See Service Manual.)	
UNLOCK	Unlock calibration.	
EXECUTE	Execute calibration steps.	
VIEW DATES	Display cal dates and count.	
SAVE	Save calibration constants.	
LOCK	Lock calibration.	
CHANGE PASSWORD	Change calibration password.	
TEST	Perform tests on SourceMeter.	
DISPLAY TESTS ⁴	Test front panel keys and display digits.	
KEYS	Test front panel keys.	
DISPLAY PATTERNS	Test display pixels and annunciators.	
CHAR SET	Test special display characters.	

Table 1-3 (cont.)

Main menu

Menu item ¹	Description	Parameters
A/D CTRL	Control auto-zero, line frequency, NPLC caching.	
AUTO ZERO ⁵	Control auto zero.	
DISABLE	Disable auto zero.	
ENABLE	Enable auto zero.	
ONCE	Force auto zero immediate update.	
LINE FREQ	Set line frequency.	50 or 60Hz, or AUTO
NPLC CACHE	Control NPLC caching.	
DISABLE	Disable NPLC caching.	
ENABLE	Enable NPLC caching.	
REFRESH	Update all NPLC values in cache immediately.	
RESET	Clear NPLC cache of all NPLC values.	
GENERAL	Select general operations.	
DIGOUT	Set Digital I/O port bit pattern.	0-15 ⁶
SERIAL#	Display serial number, firmware revision, SCPI version.	YES or NO
TIMESTAMP	Reset timestamp.	
FAN (2420, 2425, 2430, and 2440)	Set fan speed control. ALWAYS — fan runs at the same speed with the output on or off. OUTPUT ON — fan runs at low speed with the output off. See “Cooling fan,” page 1-12 .	ALWAYS or OUTPUT ON
NUMBERS	Select engineering units or scientific notation display format.	ENGR, SCIENTIFIC
BEEPER	Enable or disable beeper.	

1. Top level menu choices indicated in bold. Indentation identifies each lower submenu level.
2. When the remote operation interface selection (GPIB or RS-232) is changed, the SourceMeter performs a power-on reset. To check or change options of the selected interface, you must re-enter the menu structure.
3. Only VIEW DATES is accessible when calibration is locked. Password is required to unlock calibration.
4. Press EXIT key to cancel test.
5. Disabling auto zero will reduce measurement accuracy.
6. 0-65535 with 2499-DIGIO 16-bit option.

Rules to navigate menus

Many source-measure functions and operations are configured from the front panel menus. Use the following rules to navigate through these configuration menus:

NOTE Complete rules to edit source and compliance values are found in the Basic source-measure procedure in [Section 3](#). See [“Editing source and compliance values”](#) below for an overview.

- A menu item is selected by placing the cursor on it and pressing ENTER. Cursor position is denoted by the blinking menu item or option. The EDIT Δ and ∇ keys control cursor position.
- A displayed arrow on the bottom line indicates there are one or more additional items (or messages) to select from. Use the appropriate cursor key to display them.
- A source or parameter value range is changed by placing the cursor on the range designator (i.e., k, M, G, etc.) and using the SOURCE Δ or ∇ or RANGE Δ or ∇ keys. Note that when the next higher or lower source range is selected, the reading increases or decreases by a decade.
- A parameter value is keyed in by placing the cursor on the digit to be changed and using one of the following methods:

NOTE You can clear a parameter value by pressing the MENU key.

- Use the SOURCE Δ or ∇ or RANGE Δ or ∇ keys to increment or decrement the digit.
- Use the number keys (0 through 9) to key in the value at the selected digit.
- Use the \pm key to change source value polarity, regardless of cursor position.
- Boolean selections (such as ON/OFF and HIGH/LOW) are toggled by placing the cursor on the selection and pressing a SOURCE or RANGE up or down arrow key.
- A change is only executed when ENTER is pressed. Entering an invalid parameter generates an error, and the entry is ignored. However, entering an out-of-range value (too small or too large) selects the lower or upper limit, respectively.
- The EXIT key is used to back out of the menu structure. Any change that is not entered is cancelled when EXIT is pressed.

Editing source and compliance values

Use the following keys to edit source and compliance values:

- EDIT — selects the source or compliance display field for editing. A blinking cursor will appear in the field to be edited. If no key is pressed within a few seconds, the edit mode will be cancelled automatically.
- EDIT arrow keys — places the display cursor on the display digit to be changed.
- SOURCE Δ or ∇ — increments or decrements the source or compliance value. Note that pressing either of these keys will automatically enable the source edit mode.
- RANGE Δ or ∇ — selects the source or compliance range.
- Numeric keys (0-9) — allow you to directly enter source or compliance values.
- EXIT — exits the edit mode without waiting for the time-out period.

The basic procedure for editing source and compliance values is outlined below. See [Section 3, “Basic source-measure procedure,”](#) for more details.

1. Press the EDIT key until the blinking cursor is in either the source or compliance display field to be edited.
2. If desired, use the RANGE Δ or ∇ key to select the desired source or compliance range.
3. To simply increment or decrement the display value, use the EDIT arrow keys to place the blinking cursor on the digit to be changed, then increment or decrement the value with the SOURCE Δ or ∇ keys. Note that the source or compliance value will be updated immediately; you need not press ENTER to complete the process.
4. To enter the source or compliance value directly, simply key in the desired value with the numeric keys while the cursor is blinking. Again, the source or compliance value will be updated immediately.

Toggling the source and measure display fields

Normally, the measured reading value will appear in the upper, main display line, while the source and compliance values appear in the left and right fields respectively of the lower display line. You can toggle the source and measure display fields by pressing the TOGGLE key to place the source and measure values in the desired positions.

Disabling front panel display

Front panel display circuitry can be disabled to allow the instrument to operate at a higher speed. While disabled, the display is frozen with the following message:

FRONT PANEL DISABLED

Press LOCAL to resume.

As reported by the message, all front panel controls (except LOCAL, TRIG, and OUTPUT ON/OFF) are disabled.

Front panel control

Front panel display circuitry is controlled from the DISABLE DISPLAY configuration menu, which is accessed by pressing CONFIG and then EDIT (or TOGGLE). To select an option (NOW, NEVER, SWEEP, or STORE), use the EDIT cursor keys to place the cursor on the desired option, then press ENTER.

The options for DISABLE DISPLAY are explained as follows:

NOW — Select this option to disable the display now.

NEVER — Select this option if you do not want the display to disable.

SWEEP — Select this option if you want the display to disable while performing a sweep. The display will disable as soon as sweep is started. The display will automatically re-enable after the sweep is completed.

STORE — Select this option if you want the display to disable when storing source-measure readings in the buffer. The display will disable as soon as the buffer is enabled. The display will automatically re-enable after the storage process is completed. Note that with this option, the display will disable while performing a sweep. Sweep readings are automatically stored in the buffer.

Remote command programming

Use the following SCPI commands to enable or disable the front panel display circuitry:

:DISPlay:ENABLE OFF	Disable the display
:DISPlay:ENABLE ON	Enable the display

Configuration menus

There are a number of configuration menus that can be accessed by pressing the CONFIG key followed by the appropriate function or mode key. For example, you can configure the voltage source by pressing CONFIG then SOURCE V. Configuration menus are available for the following operating modes:

- Measure functions (V, Ω , FCTN):

- SOURCE V, SOURCE I, and RANGE:
- REL, FILTER, and LIMIT:
- TRIG:
- SWEEP, DIGITS, SPEED, and STORE:
- ON/OFF OUTPUT and Display (EDIT or TOGGLE):

2 Connections

- **Connection overview** — Discusses front/rear terminal selection and using output enable.
- **Connections to DUT** — Covers various methods for making connections to the DUT, including 4-wire remote sensing, 2-wire local sensing, cable and ohms guard, as well as sense and guard selections.

Connection overview

WARNING To prevent electric shock, test connections must be configured such that the user cannot come in contact with conductors or any DUT that is in contact with the conductors. Safe installation requires proper shields, barriers, and grounding to prevent contact with conductors. Operator protection and safety are the responsibility of the person installing the product.

During power-up, voltage spikes may appear on the terminals of the SourceMeter. These voltage spikes could be at hazardous levels (42.4V peak) and could damage sensitive DUTs. Never touch external circuitry or the test leads when powering up the SourceMeter. It is good practice to always disconnect DUTs from the SourceMeter before powering up the SourceMeter.

Hazardous voltages may be present on the output and guard terminals. To prevent electrical shock that could cause injury or death. **NEVER** make or break connections to the SourceMeter while the unit is on. Power off the equipment from the front panel or disconnect the main power cord from the rear of the SourceMeter before handling cables connected to the outputs. Putting the equipment into standby mode does not guarantee the outputs are not powered if a hardware or software fault occurs.

Front/rear terminals selection

The OUTPUT (HI and LO) and SENSE (HI and LO) terminals are accessible from both the front and rear panels. The GUARD, GUARD SENSE, and EARTH (chassis ground) terminals are only accessible from the rear panel.

Front panel terminals selection

The FRONT/REAR TERMINALS key is used to control which set of terminals is connected to the SourceMeter. Pressing this key toggles the SourceMeter connections between the front and rear terminals. When the REAR annunciator is on, the rear terminals are connected to the SourceMeter. When REAR is off, the front terminals are selected.

NOTE *When the FRONT/REAR TERMINALS key is pressed, the OUTPUT will turn OFF.*

Remote command terminals selection

Use the :ROUTe:TERMinals ([Section 18](#)) command to select the front or rear panel terminals via remote.

Test fixture output enable

A test fixture switch can be used with the SourceMeter to help protect the DUT. The SourceMeter output will turn off when the lid of the test fixture is opened. However, you must ALWAYS assume that power is present until you verify that the SourceMeter output is off. See [Section 13](#) for details.

Connections to DUT

The maximum allowable voltage differentials between terminals are labeled on the SourceMeter. [Figure 2-1](#) shows these voltage differentials for the various SourceMeter models.

WARNING To prevent electric shock and/or damage to the SourceMeter, **DO NOT** exceed the maximum allowable voltage differentials shown in [Figure 2-1](#).

The front and rear terminals of the SourceMeters are rated for connection to circuits rated Installation Category I only. Do not connect the SourceMeter terminals to CAT II, CAT III, or CAT IV circuits. Connections of the SourceMeter Input/Output terminals to circuits higher than CAT I can cause damage to the equipment or expose the operator to hazardous voltages.

Common mode current limits — As shown in [Figure 2-1](#), the maximum common mode voltage is the voltage between INPUT/OUTPUT LO and chassis ground. In order to prevent electric shock and/or damage to the SourceMeter, current from an external common mode voltage source must be limited. Current limiting can be accomplished with the use of a protective impedance or a fuse.

WARNING To prevent electric shock and/or damage to the SourceMeter, common mode voltage must be externally limited as follows:

Models 2400, 2400-LV, 2401, and 2410 — Limit common mode voltage to 250VDC, 1.05A maximum

Models 2420 and 2425 — Limit common mode voltage to 250VDC, 3.15A maximum

Model 2430 — Limit common mode voltage to 250VDC, 10.5A (pulse)

Model 2440 — Limit common mode voltage to 40VDC, 5.25A maximum

Figure 2-1
Terminal voltage differentials (rear panel)

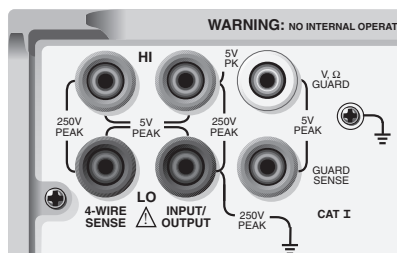

Model 2400, 2400-C

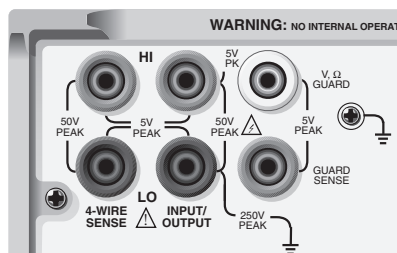

Model 2401

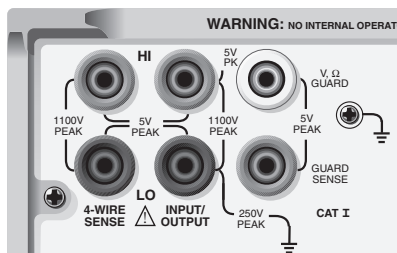

Model 2410, 2410-C

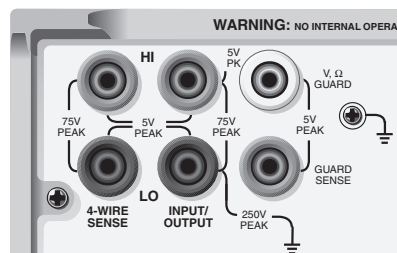

Model 2420, 2420-C

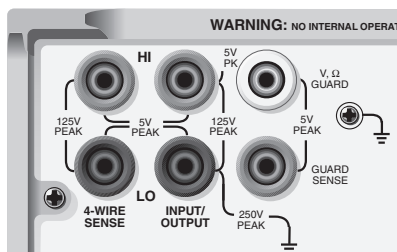

Model 2425, 2425-C, 2430, 2430-C

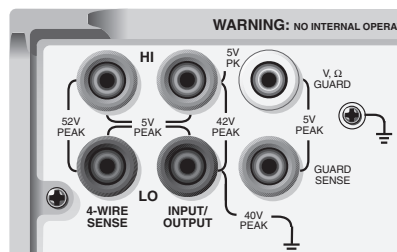

Model 2440, 2440-C

NOTE To avoid redundancy, generic SourceMeter drawings will be used in this section. A generic drawing excludes the labeling for the terminal voltage differentials.

Sensing methods

Basic source-measure operations are performed using either 2-wire local sense connections (Figure 2-2) or 4-wire remote sense connections (Figure 2-3). The factory default sense selection is local. See “Sense selection,” page 2-12, to check and/or change the sense selection. Also, see Section 4 for “Ohms sensing” issues.

WARNING There is no internal connection between earth ground and the selected INPUT/OUTPUT LO terminal of the SourceMeter. Therefore, hazardous voltages (>30V rms) can appear on that LO terminal. Typically, this can occur when the SourceMeter is operating in any mode where the output changes rapidly, such as quick, pulsed waveforms that can be generated using the ZERO, AUTO-OFF output state, or fast pulse sweep operations.

To prevent this from occurring (if your application allows it), connect the INPUT/OUTPUT LO terminal to earth ground. You can connect the LO terminal to the chassis ground screw terminal on the rear panel, or to a known safety earth ground. Note that the front panel terminals are isolated from the rear panel terminals. Therefore, if you are using the front panel terminals, ground the front panel LO terminal. If using the rear panel terminals, ground the rear panel LO terminal.

Figure 2-2
Two-wire connections (local sense)

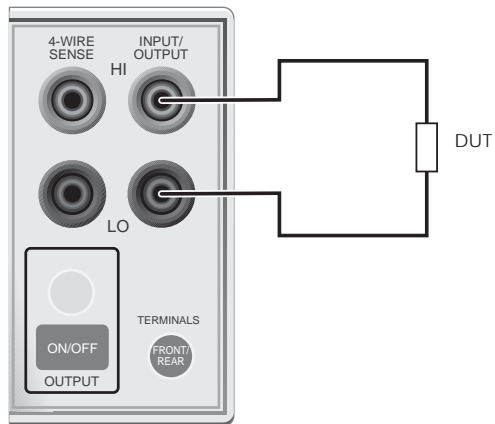

SourceMeter Front Panel

Sense Selection: 2-wire

Figure 2-3
Four-wire connections (remote sense)

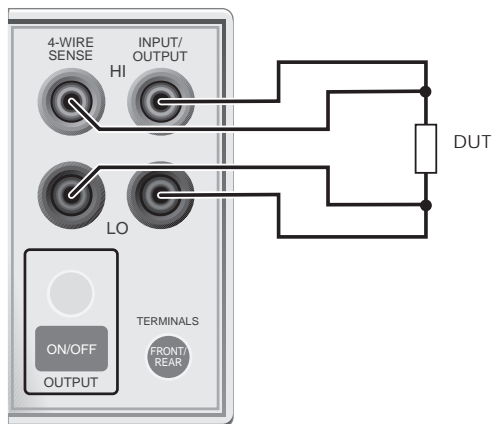

SourceMeter Front Panel

Sense Selection: 4-wire

NOTE Connections alone do not determine sense mode. For local sensing ([Figure 2-2](#)), 2-wire sensing must be selected from the *SENSE MODE* option of the *CONFIGURE V-SOURCE* menu. For remote sensing ([Figure 2-3](#)), 4-wire

sensing must be selected. The 2-wire sense mode is the BENCH and GPIB default. See [“Sense selection,” page 2-12](#), for details.

4-wire remote sensing

When sourcing and/or measuring voltage, there can be errors associated with IR drops in the test leads. Voltage source and measure accuracy are optimized by using 4-wire remote sense connections. When sourcing voltage, 4-wire remote sensing ensures that the programmed voltage is delivered to the DUT. When measuring voltage, only the voltage drop across the DUT is measured. Use 4-wire remote sensing for the following source-measure conditions:

- Test circuit impedance is $<1\text{k}\Omega$
- Optimum Ohms, V-Source, and/or V-Measure accuracy are required.

NOTE Specified accuracies for both source and measure are only achieved using 4-wire remote sensing.

WARNING When sourcing voltage in remote sense, make sure the sense leads are connected to the DUT. If a sense lead becomes disconnected, 0V will be sensed, and the SourceMeter will increase the output voltage (to possibly hazardous levels) to compensate. For increased safety, you can limit the voltage output by the SourceMeter. See [Section 3, “V-source protection,”](#) to limit the output voltage level.

NOTE When the output is turned off in the 4-wire sense mode, the sense lines are internally disconnected for safety reasons. The sense lines are automatically reconnected when the output is turned on, and 4-wire sensing is restored.

2-wire local sensing

2-wire local sense connections can only be used if the error contributed by test lead IR drop is acceptable to the user. At current levels below 100mA, the errors are usually not significant (assuming test lead resistance is not greater than 1Ω).

Since current in a series circuit is the same at all points in the loop, remote sensing does not improve I-Source or I-Measure accuracy. Thus, if sourcing current and measuring current, you can use local sensing. Other conditions that allow the use of 2-wire local sensing include:

- Test circuit impedance is $1\text{k}\Omega$ Above $1\text{G}\Omega$, guarding should also be used (“Cable guard”).
- Measure Only (V or I) operation.

Guarding methods

Cable guard

Use the high-impedance (cable) guard connection scheme shown in [Figure 2-4](#) for the following source-measure condition:

- Test circuit impedance is $>1\text{G}\Omega$

Note that cable guard must be selected for this connection scheme. See “[Guard selection](#),” [page 2-13](#), to select cable guard.

A test fixture is typically used when testing high-impedance devices. The test fixture reduces noise and protects the user from a potentially hazardous voltage on the guard shield (or plate). See [Section 6](#), “[Guard](#),” for details on using guard.

Note that the test fixture chassis is connected to In/Out LO to reduce noise.

Figure 2-4
High-impedance guarding (cable guard)

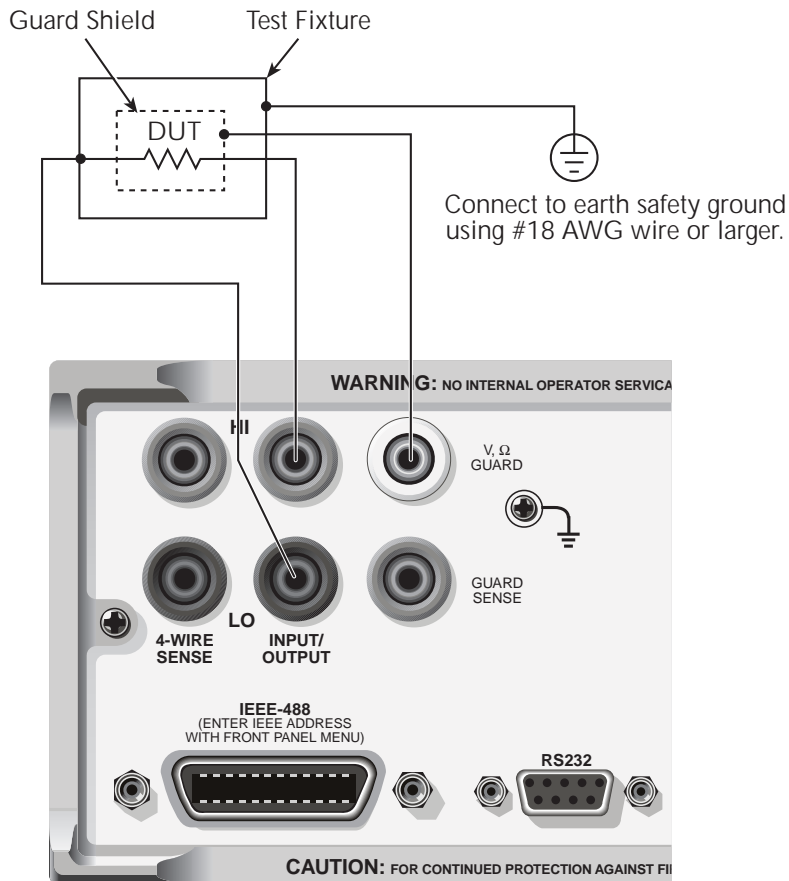

Ohms guard

Use the guarded ohms connection schemes shown in [Figure 2-5](#) for the following source-measure operation:

- In-circuit resistance measurements on the DUT where other parasitic leakage devices are present.

Note that ohms guard must be selected for this connection scheme. Ohms guard is not available for the 1A range (source or measure). See [“Guard selection,” page 2-13](#), to select ohms guard and [Section 4, “6-wire ohms measurements.”](#)

Figure 2-5 shows how to make connections to measure the resistance of a single resistor (DUT) in a resistor network. See Section 6, “Guard,” for more information on guarded ohms measurements.

The basic connection scheme for guarded ohms measurements is shown in Figure 2-5A. If the guard resistance path (R_G) is $<1k\Omega$, IR drop in the GUARD test lead could be high enough that the guard voltage at the resistor network is significantly less than the output voltage at the DUT. This results in leakage current and will corrupt the measurement. To cancel the effect of IR drop in the GUARD test lead, connect GUARD SENSE to the resistor network as shown in Figure 2-5B. Guard sense ensures that the guard voltage at the resistor network is the same as the output voltage at the DUT.

Note that if the DUT is $<1k\Omega$, you should use the 4-wire measurement method (remote sensing) by connecting SENSE HI and LO to the DUT and enabling remote sense (Figure 2-5C).

NOTE Guard current (I_G) must never exceed 50mA. If it does, guard voltage will become less than the output voltage and corrupt the measurement.

Figure 2-5
Guarded ohms measurements (ohms guard)

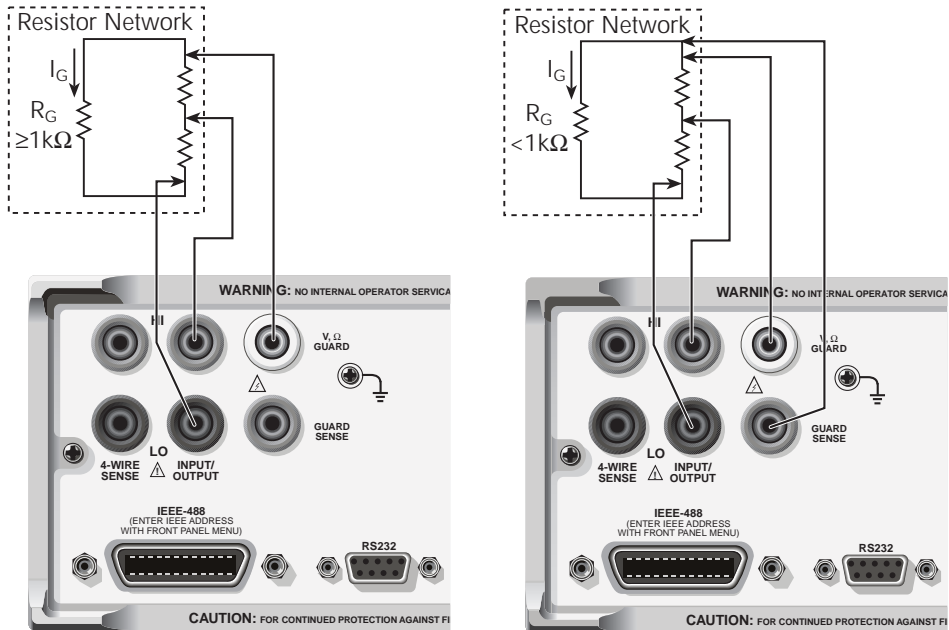

Sense Selection: 2-wire (local)

A. Basic connections

Sense Selection: 2-wire (local)

B. Connections using guard sense

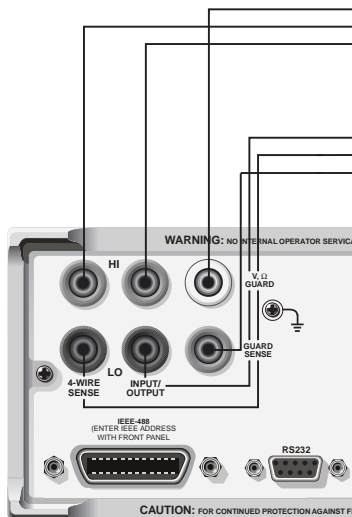

C. 6-wire ohms connections

Sense and guard selections

NOTE When sense or guard settings are changed, the OUTPUT will turn OFF.

Sense selection

When using the SENSE HI and LO terminals of the SourceMeter, 4-wire remote sensing must be selected. When not using these terminals, local sensing must be selected. Sense selection is explained as follows. See [Section 3, "Operation overview,"](#) for details on sense.

NOTE The SourceMeter defaults to the 2-wire (local) sense mode when the output is off, regardless of the sense setting. When the output is turned on, the present sense setting will be in effect.

Front panel sense selection

On power-up, the instrument is automatically set for 2-wire local sense. Perform the following steps to check and/or change the sense selection:

1. Press CONFIG and then the SOURCE V, MEAS V, or Ω key. Changing sense in one configuration menu changes it in all of the others.
2. For SOURCE V and Ω use the β and \odot keys to place the cursor (flashing menu item) on SENSE MODE and press ENTER.

NOTE Cursor position indicates the present sense selection. Two-wire indicates that local sense is selected, and 4-wire indicates that remote sense is selected. To retain the present selection, use the EXIT key to back out of the menu structure and skip the next two steps.

3. To change the sense selection, place the cursor on 4-wire to select remote sense or on 2-wire to select local sense, and press ENTER.
4. Use the EXIT key to back out of the menu structure.

Remote command sense selection

Use the :SYSTem:RSENse command ([Section 18, "SYSTem subsystem"](#)) to choose between local and remote sensing via remote. For example, send the following command to enable remote sensing:

```
:SYST:RSEN ON
```

Conversely, send this command to disable remote sensing (enable local sensing):

```
:SYST:RSEN OFF
```

Guard selection

Cable guard is used for high-impedance guarding for cables (i.e., coax and triax) and test fixtures. Ohms guard provides a high-current guard output, which allows in-circuit guarded ohms measurements. On power-up, cable guard is selected.

NOTE For 6-wire ohms measurements, use the guard output off mode. See Section 13, "Front panel output configuration," for details on the various output off states and how to select the guard output off state. See also Section 4, "6-wire ohms measurements."

Front panel guard selection

Perform the following steps to check or change the guard selection:

1. Press CONFIG and then SOURCE V, SOURCE I, or Ω . Changing guard in one configuration menu changes it in all of the others.
2. Using the SOURCE arrow keys, place the cursor (flashing menu item) on GUARD and press ENTER.

NOTE Cursor position indicates the present guard selection (OHMS or CABLE). To retain the present selection, use the EXIT key to back out of the menu structure and skip the next two steps.

3. To change the guard selection, place the cursor on the alternate selection and press ENTER.
4. Use the EXIT key to back out of the menu structure.

NOTE Do not use ohms guard with coaxial cabling, or oscillations may occur. Ohms guard cannot be selected on the 1A or higher range (source or measure).

Remote command guard selection

Use the :SYSTem:GUARd command (Section 18, "SYSTem subsystem") to choose between cable and ohms guard mode via remote. For example, send the following command to enable ohms guard:

```
:SYST:GUAR OHMS
```

Conversely, send this command to enable cable guard:

```
:SYST:GUAR CABL
```

3

Basic Source-Measure Operation

- **Operation overview** — Discusses source-measure capabilities, compliance limit, and fundamental source-measure configuration.
- **Operation considerations** — Covers warm-up, auto zero, V-source protection, and source delay.
- **Basic source-measure procedure** — Describes the basic procedure for setting up the SourceMeter for source-measure operations, including selecting the source function, output values, and compliance limits; choosing measurement range and function; and turning the output on and off.
- **Measure only** — Covers how to use the SourceMeter for measurements only.
- **Sink operation** — Describes sink operation.

WARNING - CAUTION

The SourceMeter uses a heat sink to dissipate heat. Also, the Models 2410, 2420, 2430, and 2440 have a cooling fan. The left side of the case is cut out to expose the black, finned heat sink. This heat sink gets hot and could be hot enough to cause burns. Even if the instrument is turned off, you should assume that the heat sink is still hot as it takes considerable time for it to cool off.

WARNING When handling the SourceMeter, **NEVER touch the heat sink located on the left side of the case. This heat sink could be hot enough to cause burns.**

NOTE See [Section 1, “Cooling fan,”](#) for operation details on the cooling fan.

Excessive heat could damage the SourceMeter and at the very least, degrade its performance. The SourceMeter must be operated in an environment where the ambient temperature does not exceed 50°C.

CAUTION To prevent damaging heat build-up, and thus ensure specified performance, adhere to the following precautions:

- Keep the heat sink free of dust, dirt, and contaminants, since its ability to dissipate heat could become impaired.
- Keep the bottom cooling vents from becoming blocked. NEVER remove the plastic feet and place the SourceMeter directly on a flat surface. NEVER operate the SourceMeter when it is sitting on a conformable surface (such as a carpet). This could block the bottom cooling vents.
- Do not position any devices adjacent to the SourceMeter that force air (heated or unheated) into or onto its surfaces or cooling vents. This additional airflow could compromise accuracy performance.
- When rack mounting the SourceMeter, make sure there is adequate airflow around the bottom and sides to ensure proper cooling. Adequate airflow enables air temperatures within approximately one inch of the SourceMeter surfaces to remain within specified limits under all operating conditions.
- Rack mounting high power dissipation equipment adjacent to the SourceMeter could cause excessive heating to occur. The specified ambient temperatures must be maintained around the surfaces of the SourceMeter to specified accuracies.

- A good measure to ensure proper cooling in rack situations with convection cooling only is to place the hottest equipment (i.e., power supply) at the top of the rack. Precision equipment, such as the SourceMeter, should be placed as low as possible in the rack where temperatures are the coolest. Adding spacer panels below the SourceMeter will help ensure adequate air flow.

Operation overview

Source-measure capabilities

From the front panel, the SourceMeter can be configured to perform the following operations:

- Source voltage — Display current and/or voltage measurement
- Source current — Display voltage and/or current measurement
- Measure resistance — Display voltage or current component of measurement
- Measure only (V or I) — Display voltage or current measurement

Voltage and Current — [Table 3-1](#) lists the source and measure limits for the voltage and current functions.

The full range of operation is explained in [Section 6](#), “[Overheating protection](#)” and “[Operating boundaries](#).”

NOTE *Output transient recovery — The time required for the V-source to recover to its original value (within 0.1% plus load regulation errors) after a step change in load current is <250μsec. This does not include the response time of autoranging or the second order effects on loads that are not purely resistive.*

Load regulation — The voltage specification for V-source mode load changes is 0.01% +1mV. This means that on the 200mV range, the load current can be changed from zero to full scale with less than 1.02mV of error. Calculation:

$$\text{error} = (0.01\% \times 0.2V) + 1mV = 1.02mV$$

Assuming a 0 to 1A change in current, the output impedance equates to 1.02mΩ (1.02mV/1A = 1.02mΩ). This level can only be achieved using 4-wire remote sensing.

Table 3-1
Source-measure capabilities

2400/2400-LV/2401			2410		
Range	Source	Measure	Range	Source	Measure
200mV 2V 20V 200V*	±210mV ±2.1V ±21V ±210V	±211mV ±2.11V ±21.1V ±211V	200mV 2V 20V 1000V	±210mV ±2.1V ±21V ±1.1kV	±211mV ±2.11V ±21.1V ±1.1kV
1µA 10µA 100µA 1mA 10mA 100mA 1A	±1.05µA ±10.5µA ±105µA ±1.05mA ±10.5mA ±105mA ±1.05A	±1.055µA ±10.55µA ±105.5µA ±1.055mA ±10.55mA ±105.5mA ±1.055A	1µA 10µA 100µA 1mA 20mA 100mA 1A	±1.05µA ±10.5µA ±105µA ±1.05mA ±21mA ±105mA ±1.05A	±1.055µA ±10.55µA ±105.5µA ±1.055mA ±21.1mA ±105.5mA ±1.055A
(*2400 only) Max Power = 22W			Max Power = 22W		
2420			2425/2430		
Range	Source	Measure	Range	Source	Measure
200mV 2V 20V 60V	±210mV ±2.1V ±21V ±63V	±211mV ±2.11V ±21.1V ±63.3V	200mV 2V 20V 100V	±210mV ±2.1V ±21V ±105V	±211mV ±2.11V ±21.1V ±105.5V
10µA 100µA 1mA 10mA 100mA 1A 3A	±10.5µA ±105µA ±1.05mA ±10.5mA ±105mA ±1.05A ±3.15A	±10.55µA ±105.5µA ±1.055mA ±10.55mA ±105.5mA ±1.055A ±3.165A	10µA 100µA 1mA 10mA 100mA 1A 3A/10A	±10.5µA ±105µA ±1.05mA ±10.5mA ±105mA ±1.05A *	±10.55µA ±105.5µA ±1.055mA ±10.55mA ±105.5mA ±1.055A **
Max Power = 66W			2425 and 2430 Max Power DC Mode: 110W (105V, 1.05A) 66W (21V, 3.15A) Pulse Mode: 1.1kW (2430 only)		

Table 3-1 (cont.)
Source-measure capabilities

2440		
Range	Source	Measure
200mV	±210mV	±211mV
2V	±2.1V	±2.11V
10V	±10.5V	±10.5V
40V	±42V	±42V
10µA	±10.5µA	±10.55µA
100µA	±105µA	±105.5µA
1mA	±1.05mA	±1.055mA
10mA	±10.5mA	±10.55mA
100mA	±105mA	±105.5mA
1A	±1.05A	±1.055A
5A	±5.25A	±5.25A
Max Power = 66W		

* ±3.15A (DC mode; 2425 and 2430)

±10.5A (Pulse mode; 2430 only)

** ±3.165A (DC mode; 2425 and 2430)

±10.55A (Pulse mode; 2430 only)

Compliance limit

When sourcing voltage, the SourceMeter can be set to limit current. Conversely, when sourcing current, the SourceMeter can be set to limit voltage. The SourceMeter output will not exceed the compliance limit. [Table 3-2](#) summarizes compliance limits according to range. See [Section 6](#) for more details on compliance limit.

Table 3-2
Compliance limits

2400/2400-LV/2401		2410		2420	
Measure range	Maximum compliance value	Measure range	Maximum compliance value	Measure range	Maximum compliance value
200mV	±210mV	200mV	±210mV	200mV	±210mV
2V	±2.1V	2V	±2.1V	2V	±2.1V
20V	±21V	20V	±21V	20V	±21V
200V*	±210V	1000V	±1.1kV	60V	±63V
1µA	±1.05µA	1µA	±1.05µA	10µA	±10.5µA
10µA	±10.5µA	10µA	±10.5µA	100µA	±105µA
100µA	±105µA	100µA	±105µA	1mA	±1.05mA
1mA	±1.05mA	1mA	±1.05mA	10mA	±10.5mA
10mA	±10.5mA	20mA	±21mA	100mA	±105mA
100mA	±105mA	100mA	±105mA	1A	±1.05A
1A	±1.05A	1A	±1.05A	3A	±3.15A
2425/2430		2440			
Measure range	Maximum compliance value	Measure range	Maximum compliance value		
200mV	±210mV	200mV	±210mV		
2V	±2.1V	2V	±2.1V		
20V	±21V	10V	±10.5V		
100V	±105V	40V	±42V		
10µA	±10.5µA	10µA	±10.5µA		
100µA	±105µA	100µA	±105µA		
1mA	±1.05mA	1mA	±1.05mA		
10mA	±10.5mA	10mA	±10.5mA		
100mA	±105mA	100mA	±105mA		
1A	±1.05A	1A	±1.05A		
3A/10A	**	5A	±5.25A		

* 2400 only

** ±3.15A (2425 and 2430 DC mode)

±10.5A (Pulse mode; 2430 only)

Setting the compliance limit

Front panel compliance limit

Set the compliance limit from the front panel as follows:

1. Select the desired source and measure functions using the MEAS and SOURCE keys.
2. Press the EDIT key until the cursor flashes in the compliance (Compl:) display field.
3. Select the desired compliance range using the RANGE arrow keys.
4. To increment or decrement the compliance value, use the EDIT arrow keys to place the cursor over the digit to be changed, then press the SOURCE arrow keys to increment or decrement the compliance value.
5. To change the compliance value directly, simply enter the value using the numeric keys while the cursor is flashing in the compliance display field.

Compliance range synchronization

Enabling this feature will force the measurement range to follow the compliance range setting when autoranging is off. When the compliance value is set, the measurement range will be on the same range as the compliance setting.

You can enable range synchronization by pressing CONFIG then MEAS V (for voltage) or MEAS I (for current). Select CMPL-RANGE-SYNC, then ON to enable, or OFF to disable range synchronization.

Remote compliance limit

[Table 3-3](#) summarizes basic commands to program the compliance limit. See [Section 18, “Set compliance parameters,”](#) for more details on these commands. To program the compliance, simply send the command using the desired parameter. For example, the following command sets the current compliance to 50mA:

```
:SENS:CURR:PROT 50E-3
```

Similarly, the following command sets the voltage compliance to 4V:

```
:SENS:VOLT:PROT 4
```

Table 3-3

Compliance commands

Command	Description
:SENSe:CURRent:PROTection <n>	Set current compliance (n = compliance).
:SENSe:VOLTage:PROTection <n>	Set voltage compliance (n = compliance).

Basic circuit configurations

The fundamental source-measure configurations for the SourceMeter are shown in [Figure 3-1](#). When sourcing voltage, you can measure current or voltage (configuration A). When sourcing current, you can measure voltage or current (configuration B).

See [Section 6, “Basic circuit configurations,”](#) for more detailed information on these circuit configurations.

Figure 3-1
Fundamental source measure configuration

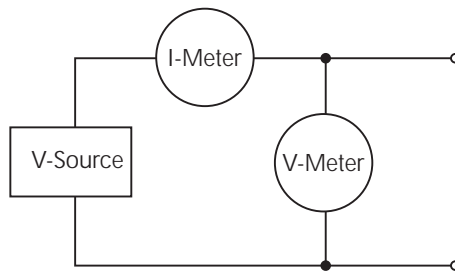

A. Source V

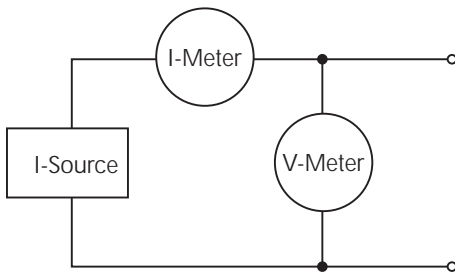

B. Source I

Operation considerations

The following paragraphs discuss warm-up period, auto zero, V-source protection, and source delay.

Warm-up

The SourceMeter must be turned on and allowed to warm up for at least one hour to achieve rated accuracies See [Appendix A](#) for specifications.

Auto zero

Every A/D conversion (reading) is calculated from a series of zero, reference, and signal measurements. With auto zero enabled, all three of these measurements are performed for each reading to achieve rated accuracy. With auto zero disabled, zero and reference are not measured. This increases measurement speed, but zero drift will eventually corrupt accuracy. With auto zero disabled, periodically change measurement speed.

Temperature changes across components within the instrument can cause the reference and zero values for the A/D converter to drift due to thermo-electric effects. Auto zero acts to negate the effects of drift in order to maintain measurement accuracy over time. Without auto zero enabled, measurements can drift and become erroneous.

Front panel auto zero

Set the auto zero from the front panel as follows:

1. Press the MENU key.
2. Select A/D CTRL from the main menu, then press ENTER.
3. Select AUTO ZERO, then press ENTER.
4. Select ENABLE or DISABLE as appropriate, then press ENTER.
5. Press EXIT as necessary to return to normal display.

Remote command auto zero

Use the :SYSTem:AZERo command to enable or disable auto zero via remote. See [Section 18](#), “SYSTem subsystem.” For example, send the following command to disable auto zero:

```
:SYST:AZER ON
```

Conversely, send this command to disable auto-zero:

```
:SYST:AZER OFF
```

NPLC caching

NPLC caching speeds up source memory sweeps by caching A/D reference and zero values. When NPLC caching is enabled (using the NPLC-CACHE/ENABLE menu selection), the A/D reference and zero values will be saved for up to the 10 most recent voltage, current, and resistance measurement functions settings. Whenever the integration rate is changed via the SPEED key, a recalled user setup (using the SAVESETUP/RESTORE menu selection), or during a source memory recall (either with the -MEMORY/RESTORE menu or during a source memory sweep), NPLC caching will occur. If the integration rate is already stored in the cache, the stored reference and zero values are recalled and used. Otherwise, a reference and zero value are acquired and stored in the cache. If there are already 10 NPLC values stored, the oldest one will be overwritten by the newest one.

NOTE Auto zero should be disabled for maximum source memory sweep speed; otherwise the cache is of little use. With auto zero enabled, new A/D reference and zero values are taken for every reading and saved into the cache, slowing down sweep operation. However, with auto zero disabled, measurements may drift and become erroneous. To minimize drift when using NPLC caching with auto zero disabled, periodically select AUTO-ZERO/ONCE in the A/D-CTRL menu to force an immediate auto zero update.

NPLC cache setup

Follow the steps below to enable and use NPLC caching with a source memory sweep:

1. Press the MENU key, select A/D-CTRL, then press ENTER.
2. Select AUTO-ZERO, then press ENTER.
3. Choose DISABLE, then press ENTER to disable auto zero.
4. From the A/D CONTROLS menu, select NPLC-CACHE, then press ENTER.
5. Select ENABLE, then press ENTER to enable NPLC caching.
6. Use the EXIT key to back out of the main menu structure.
7. Set up the source memory parameters, and run the source memory sweep. (See [Section 10](#), “[Performing a source memory sweep](#).”)

V-source protection

Use V-source protection to select the maximum voltage level the SourceMeter can output. Available settings are listed as follows:

SourceMeter	V-Source protection limit settings
2400	20V, 40V, 60V, 80V, 100V, 120V, 160V, NONE (>160V)
2401	20V, NONE (>20V)
2410	20V, 40V, 100V, 200V, 300V, 400V, 500V, NONE (>500V)
2420	6V, 12V, 18V, 24V, 30V, 36V, 48V, NONE (>48V)
2425/2430	10V, 20V, 30V, 40V, 50V, 60V, 80V, NONE (>80V)
2440	4V, 8V, 12V, 16V, 20V, 24V, 32V, NONE (>40V)

These are absolute values with 5% tolerance. The power-on default is NONE.

WARNING Even with the voltage protection limit set to the lowest value, **NEVER** touch anything connected to the terminals of the SourceMeter when the OUTPUT is ON. Always assume that a hazardous voltage (>30V rms) is present when the OUTPUT is ON.

To prevent damage to DUT (devices-under-test) or external circuitry, **DO NOT** program the V-Source to levels that exceed the voltage protection limit.

Use caution when floating the SourceMeter >30V rms.

Front panel V-source protection

To program V-source protection from the front panel:

1. Press CONFIG then SOURCE V.
2. Select PROTECTION from the displayed choices, then press ENTER.
3. Select the desired protection value, then press ENTER.
4. Press EXIT to return to normal display.

Remote command V-source protection

Use the :SOURce:VOLTage:PROTection command to program the V-source protection value via remote. See [Section 18, "Set voltage limit,"](#) for details. For example, the following command sets the protection value for the Model 2400 or 2410 to 20V:

```
:SOUR:VOLT:PROT 20
```

Source delay

NOTE For the Model 2430 Pulse Mode, source delay is not used. The following information assumes that the Model 2430 is in the DC Mode of operation (“Vpls” or “Ipls” displayed). To select the DC Mode, press CONFIG and then SOURCE V or I, select SHAPE from the available menu items, and then select DC.

The source delay options are used to set the settling time for the source. This source delay is the delay phase of the Source-Delay-Measure (SDM) cycle. See [Section 6](#). The auto delay option is used to automatically set the delay. The delay period is range dependent ([Table 3-4](#)).

The delay option is used to manually set the delay from 000.00000 seconds to 9999.99900 seconds. Manually setting the delay disables auto delay.

Table 3-4
Auto source delay

2400/2400-LV/2401 I-range	2410 I-range	2420 I-range	2425/2430 I-range	2440 I-range	Auto delay (Source V)	Auto delay (Source I)
1µA	1µA	10µA	10µA	10µA	3msec	3msec
10µA	10µA	100µA	100µA	100µA	2msec	1msec
100µA	100µA	1mA	1mA	1mA	1msec	1msec
1mA	1mA	10mA	10mA	10mA	1msec	1msec
10mA	20mA	100mA	100mA	100mA	1msec	1msec
100mA	100mA	1A	1A	1A	1msec	1msec
1A	1A	3A	3A/10A*	5A	1msec	2msec

*10A range only on Model 2430.

Front panel source delay

To set the manual source delay from the front panel:

1. Press CONFIG then SOURCE V.
2. Select DELAY from the displayed choices, then press ENTER.
3. Enter the desired DELAY value, then press ENTER.
4. Press EXIT to return to normal display.

To set the auto source delay state from the front panel:

1. Press CONFIG then SOURCE V.
2. Select AUTO DELAY from the displayed choices, then press ENTER.
3. Select ENABLE or DISABLE as desired, then press ENTER.

4. Press EXIT to return to normal display.

Remote command source delay

Use the :SOURce:DELAy or :SOURce:DELAy:AUTO commands to program the source delay via remote. (See [Section 18](#), “[Set delay](#),” for details.) For example, the following command sets the source delay to 500ms:

```
:SOUR:DEL .5
```

Similarly, send the following command to enable auto delay:

```
:SOUR:DEL:AUTO ON
```

Basic source-measure procedure

Front panel source-measure procedure

Use the following procedure to perform the basic source-measure operations of the SourceMeter. See [Section 4, “Ohms Measurements,”](#) to measure ohms.

NOTE For the Model 2430, the following procedure pertains to the DC Mode of operation. Pulse Mode operation is covered in [Section 5](#). If the Model 2430 is in the Pulse Mode (Vpls or Ipls displayed in the source field), you can select the DC Mode from the source/pulse configuration menu. Press CONFIG SOURCE V or I, select the SHAPE menu item, then select DC. Use the EXIT key to return to the normal display. In the DC Mode, Vsrc or Isrc is displayed in the source field.

The following procedure assumes that the SourceMeter is already connected to the DUT as explained in [Section 2, “Connections.”](#)

Step 1: Select source.

Press SOURCE V to select the V-Source or press SOURCE I to select the I-Source. The presently programmed source value (V_{SRC} or I_{SRC}) and compliance level (Cmpl) are displayed. Note that the “OFF” message is displayed to indicate that the source is off (ON/OFF indicator off).

Step 2: Set source level and compliance limit.

The source level is the voltage or current setting of the selected source (V-Source or I-Source). A compliance limit acts as a power limiter to the DUT and is set to protect the DUT from damaging currents or voltages. When using the V-Source, a current compliance is set. When using the I-Source, a voltage compliance is set. Compliance defines the maximum absolute value the SourceMeter can output.

Note that compliance can also be determined by the measurement range. Depending on which value is lower, compliance occurs at the programmed value (real compliance) or at the maximum compliance value for the present fixed measurement range (range compliance). For example, with compliance set to 2V and the 200mV measurement range selected, compliance will occur at 210mV. On the 20V measurement range, compliance will occur at 2V. See [Section 6, “Compliance limit,”](#) for details on real and range compliance.

NOTE The SourceMeter must be in the edit mode (EDIT annunciator ON) to set source and compliance values. The edit mode is selected by pressing the EDIT key. The flashing digit for the source or compliance reading indicates that the SourceMeter is in the edit mode. If no editing operation

is performed within six seconds, the edit mode times out and is cancelled. To return to the edit mode, press EDIT again. While in the edit mode, the EDIT key toggles between the source value and the compliance value.

The SOURCE and EDIT arrow keys also enable the edit mode. They choose the last selected field.

When editing the source value, the source is updated immediately, allowing you to adjust the source value while the output is on.

The source value cannot be changed while the SourceMeter is performing a sweep. This occurs with Output ON and either the SWEEP key is pressed, Offset Compensation is enabled under Ohms, or OFF-COMP-OHMS, VOLT-COEFF, or VAR-ALPHA functions are enabled.

When editing the compliance value, compliance is not updated until ENTER is pressed or the edit mode is allowed to time out.

EDIT always goes to the source field first, except while sweeping, in which case it goes into the compliance field.

Source and compliance values cannot be edited in AUTO OHMS mode. MANUAL OHMS allows you to edit source and compliance. See [Section 4](#).

Perform the following steps to edit the source and compliance values:

1. Press EDIT to enter the edit mode. The flashing digit indicates which reading (source or compliance) is presently selected for editing. If you wish to edit the other field, press EDIT again.
2. Use the RANGE arrow keys to select a range that will accommodate the value you want to set. (See [Section 7](#) for range information.) For best accuracy, use the lowest possible source range.
3. Enter the desired source or compliance value. There are two methods to edit the value: value adjust and numeric entry.

NOTE *To clear the source value to 0V or 0A, press the MENU key while in the edit source field.*

- Value adjust — To adjust the value, use the EDIT cursor keys to place the cursor at the appropriate position, and use the SOURCE arrow keys to increment or decrement the value.
- Numeric entry — When the edit mode is entered, the cursor is located on the most significant digit of the value. From this position, you can key in the value using the number keys (0 through 9). After each number is keyed in, the cursor moves one position to the right. If desired, you can use the EDIT cursor keys to place the cursor on a digit to be changed, and press the appropriate number key. The cursor does not

- have to be on the polarity sign of the value to change polarity. If the MENU key is pressed, the Source Value will be clear to 0V or 0A.
4. To edit the other field, press EDIT to select it, and repeat steps 1 and 2.
 5. When finished editing the source and compliance values, press ENTER or wait six seconds to exit from the edit mode.

NOTE When a compliance limit value is entered, the SourceMeter automatically goes to the lowest (most sensitive) compliance range that will accommodate that value.

For the Models 2400, 2400-LV, 2401, and 2410, the lowest compliance levels that can be set are 0.00100 μ A (1nA) and 000.200mV (200 μ V). For the Models 2420, 2425, 2430, and 2440, the levels are 00.0100 μ A (10nA) and 000.200mV (200 μ V).

Step 3: Select measurement function and range.

Select the desired measurement function by pressing MEAS V (voltage) or MEAS I (current).

When measuring the source (i.e., Source V Measure V), you cannot select the range using the measurement RANGE keys. The selected source range determines the measurement range.

When not measuring the source (i.e., Source V Measure I), measurement range selection can be done manually or automatically. When using manual ranging, use the lowest possible range for best accuracy. In autorange, the SourceMeter automatically goes to the most sensitive range to make the measurement.

Step 4: Turn output on.

Turn the output on by pressing the ON/OFF OUTPUT key. The OUTPUT indicator will turn on to indicate the output is on.

Step 5: Observe readings on the display.

The SourceMeter is in compliance if the "Cmpl" label or the units label (i.e. "mA") for the displayed compliance setting is flashing. If the "Cmpl" label is flashing, real compliance has occurred. The output is clamped at the displayed compliance value. If the units label is flashing, range compliance has occurred. The output is clamped at the maximum compliance value for the present fixed measurement range. For example, if presently on the 2V measurement range, a flashing units label for the voltage compliance value indicates that the output is clamped at 2.1V.

Step 6: Turn output off.

When finished, turn the output off by pressing the ON/OFF OUTPUT key. The OUTPUT indicator light will turn off.

Remote command source-measure procedure

Basic source-measurement procedures can also be performed via remote by sending appropriate commands in the right sequence. The following paragraphs summarize the basic commands and give a simple programming example.

Basic source-measure commands

[Table 3-5](#) summarizes basic source-measure commands. See [Section 18](#) for more information on using these commands.

NOTE The first command in [Table 3-5](#) (SOURce:FUNction:SHAPE DC) applies only to the Model 2430. It is not valid for Models 2400, 2410, 2420, 2425, and 2440.

Table 3-5

Basic source-measure commands

Command	Description
:SOURce:FUNction:SHAPE DC	Select DC Mode of operation (Model 2430 only).
:SOURce:FUNction[:MODE] <name>	Select source function (name = VOLTage or CURRent).
:SOURce:CURRent:MODE FIXed	Select fixed sourcing mode for I-source.
:SOURce:VOLTage:MODE FIXed	Select fixed sourcing mode for V-source.
:SOURce:CURRent:RANGe <n>	Select I-source range (n = range).
:SOURce:VOLTage:RANGe <n>	Select V-source range (n = range).
:SOURce:CURRent:LEVel <n>	Set I-source amplitude (n = amplitude in amps).
:SOURce:VOLTage:LEVel <n>	Set V-source amplitude (n = amplitude in volts).
:SENSe:FUNction <function>	Select measure function (function = "VOLTage" or "CURRent").
:SENSe:CURRent:PROTection <n>	Set current compliance (n = compliance).
:SENSe:VOLTage:PROTection <n>	Set voltage compliance (n = compliance).
:SENSe:CURRent:RANGe <n>	Set current measure range (n = range).
:SENSe:VOLTage:RANGe <n>	Set voltage measure range (n = range).
:OUTPut <state>	Select output state (state = ON or OFF).
:READ?	Trigger and acquire reading.

Source-measure programming example

Table 3-6 summarizes the command sequence for a basic source-measure procedure. Note that the steps correspond to those listed previously in “[Front panel source-measure procedure](#).” These commands set up the SourceMeter as follows:

- Source function and range: volts, 20V
- Source mode: fixed
- Source output level: 10V
- Current compliance: 10mA
- Measure function and range: current, 10mA

Table 3-6

Basic source-measure programming example

Step ¹	Action	Commands ^{2,3}	Comments
1	Select source function, mode	*RST :SOUR:FUNC VOLT	Restore GPIB defaults. Select voltage source.
2	Set source range, level, compliance	:SOUR:VOLT:MODE FIXED :SOUR:VOLT:RANG 20 :SOUR:VOLT:LEV 10	Fixed voltage source mode. Select 20V source range. Source output = 10V.
3	Set measure function, range	:SENS:CURR:PROT 10E-3 :SENS:FUNC "CURR" :SENS:CURR:RANG 10E-3	10mA compliance. Current measure function. 10mA measure range.
4	Turn on output	:FORM:ELEM CURR :OUTP ON	Current reading only. Output on before measuring.
5	Read data	:READ?	Trigger, acquire reading.
6	Turn off output	:OUTP OFF	

1. Steps correspond to front panel steps listed previously in “[Front panel source-measure procedure](#).”

2. Commands must be sent in order given.

3. Instrument must be addressed to talk after :READ? to acquire data.

Measure only

Front panel measure only

In addition to being used for conventional source-measure operations, the SourceMeter can also be used to measure only voltage or current. Perform the following steps to use the SourceMeter to measure voltage or current:

1. Select source-measure functions.
Measure voltage only (voltmeter) — Press SOURCE I to select the I-Source, and press MEAS V to select the voltage measurement function.
Measure current only (ammeter) — Press SOURCE V to select the V-Source, and press MEAS I to select the current measurement function.
2. Set source and compliance levels.
Use the editing procedure provided in step 2 of the Basic source-measure procedure to edit the source and compliance levels as follows:
 - a. Select the lowest source range and set the source level to zero (0.00000 μ A or 000.000mV).
 - b. Set compliance to a level that is higher than the expected measurement.

CAUTION When using the SourceMeter as a voltmeter, V-Compliance must be set higher than the voltage that is being measured. Failure to do this could result in instrument damage due to excessive current that will flow into the SourceMeter.

3. Select range.
Use the RANGE arrow keys to select a fixed measurement range that will accommodate the expected reading. Use the lowest possible range for best accuracy. When measuring current, AUTO range can be used instead. The SourceMeter will automatically go to the most sensitive range. When measuring voltage, DO NOT use AUTO range (see the following CAUTION).

CAUTION When using the SourceMeter as a voltmeter only, DO NOT use AUTO range and NEVER select a measurement range that is below the applied signal level. For these conditions, high current will be drawn from the external source. This high current could damage the external source or test circuit.

4. Connect voltage or current to be measured. Connect the DUT to the SourceMeter using 2-wire connections. (Figure 2-2).
5. Turn output on. Press the ON/OFF key to turn the output on.
6. Take reading from display.
7. When finished, turn output off.

Remote command measure only

Table 3-7 summarizes the basic command sequence for measure only. The steps outlined correspond to those in the “Front panel measure only” sequence above.

Table 3-7

Measure only programming example

Step ¹	Action	Commands ^{2,3}	Comments
1	Select measure, source functions	*RST :SOUR:FUNC CURR :SOUR:CURR:MODE FIXED :SENS:FUNC "VOLT"	Restore GPIB defaults. Current source function. Fixed current source mode. Volts measure function.
2	Set source and compliance	:SOUR:CURR:RANG MIN :SOUR:CURR:LEV 0	Lowest source range. 0A source level.
3	Select volts measure range	:SENS:VOLT:PROT 25 :SENS:VOLT:RANG 20 :FORM:ELEM VOLT	25V compliance. 20V range. Volts only.
5	Turn on output	:OUTP ON	Output on before measuring.
6	Read data	:READ?	Trigger, acquire reading.
7	Turn off output	:OUTP OFF	Output off after measuring.

1. Steps correspond to front panel steps listed previously in “Front panel measure only.”
2. Commands must be sent in order given.
3. Instrument must be addressed to talk after :READ? to acquire data.

Sink operation

When operating as a sink (V and I have opposite polarity), the SourceMeter is dissipating power rather than sourcing it. An external source (i.e., battery) or an energy storage device (i.e., capacitor) can force operation into the sink region.

For example, if a 12V battery is connected to the V-Source (In/Out HI to battery high) that is programmed for +10V, sink operation will occur in the second quadrant (Source +V and measure -I).

CAUTION When using the I-Source as a sink, **ALWAYS** set V-Compliance to a level that is higher than the external voltage level. Failure to do so could damage the instrument due to excessive current that will flow into the SourceMeter.

NOTE The sink operating limits are shown in [Section 6](#), “Operating boundaries.”

Battery charging/discharging

WARNING To prevent personal injury or damage to the SourceMeter, do not attempt to charge non-rechargeable batteries.

Some of the common batteries that can be charged with a SourceMeter are:

Nickel Cadmium (Ni-Cd)

Nickel Metal Hydride (Ni-MH)

Lithium Ion (Li-ion)

Rechargeable Alkaline

Lead Acid

If you are working with a battery type that is not listed here, please contact your local Keithley representative or call one of our Applications Engineers at 1-800-348-3735 (U.S and Canada only) to obtain technical assistance.

WARNING Always follow the battery manufacturers requirements for charging or discharging batteries using a SourceMeter. Failure to properly charge or discharge batteries may cause them to leak or explode resulting in personal injury and property damage. Over voltage and current protection should be provided in the charge circuit, external to the SourceMeter, when charging batteries without built-in protection.

Do not attempt to charge or discharge batteries exceeding the current or voltage requirements listed below:

Model 2400, 2400-C: 21V @ 1.05A or 210V @ 105mA

Model 2400-LV, 2401: 21V @ 1.05A

Model 2410, 2410-C: 21V @ 1.05A or 1100V @ 21mA

Model 2420, 2420-C: 21V @ 3.15A or 63V @ 1.05A

Model 2425, 2425-C: 21V @ 3.15A or 105V @ 1.05A

Model 2430, 2430-C: 105V @ 1.05A or 105V @ 10.5A (pulse mode)

Model 2440, 2440-C: 10.5V @ 5.25A or 42V @ 1.05A

When charging a battery, the SourceMeter is operating as a source. When discharging a battery, the SourceMeter is operating as a sink. Use the V-Source to charge and discharge batteries. Perform the following steps for both charging and discharging:

1. Connect Input/Output HI to the positive (+) terminal of the battery and Input/Output LO to the negative (-) terminal of the battery.
2. Configure the SourceMeter to source voltage and measure current.
3. Set I-compliance to the current level at which the battery is to be charged or discharged.
4. Select an appropriate current measurement range or use AUTO range.
Battery charging — To charge the battery, program the SourceMeter to output a voltage that is equivalent to the voltage rating of the battery. For example, to charge a 10V battery, set the SourceMeter to source 10V. As the battery fully charges, current will decrease until it reaches zero or near zero (battery charged).

CAUTION When the SourceMeter goes into compliance, the V-source becomes an I-source (or the I-source becomes a V-source). For this reason, make sure the voltage compliance is higher than the battery voltage. See Section 6 for more details.

Battery discharging — To discharge the battery, program the SourceMeter to output 0V. In this configuration, the SourceMeter operates as a sink to discharge the battery. Current from the battery flows into the HI terminal of the SourceMeter resulting in negative current measurements. As the battery discharges, current will gradually decrease until it reaches zero (battery discharged).

NOTE When using the V-Source to charge and discharge batteries, use the HIGH-IMPEDANCE output-off state (Section 13). This output-off state opens the output relay when the OUTPUT is turned off. This open circuit

condition keeps the external battery from discharging while the output is off.

CAUTION If using the I-Source to charge and/or discharge batteries, the following precautions must be observed. Failure to observe these precautions could result in damage to the SourceMeter that is not covered by the warranty.

Make sure the external voltage **NEVER** exceeds the voltage compliance setting of the I-Source. This will cause excessive current to be drawn from the external battery or source.

Make sure the output off state of the I-Source is set for **HIGH-IMPEDANCE**. This setting opens the output relay when the **OUTPUT** is turned **OFF**. With the **NORMAL** output off state selected, turning the output off sets voltage compliance to zero. This 0V compliance condition will cause excessive current to be drawn from the external battery or source. See [Section 13, “Front panel output configuration”](#) to select the high-impedance output off state.

Sink programming example

[Table 3-8](#) lists a command sequence to program the SourceMeter for sink operation.

Table 3-8

Sink programming example

Command	Description
*RST	Restore GPIB defaults.
:SOUR:FUNC VOLT	V-source function.
:SOUR:VOLT:MODE FIXED	Fixed source mode.
:SENS:FUNC "CURR"	Current measure function.
:SENS:CURR:RANG:AUTO ON	Auto measure range.
:SENS:CURR:PROT 100E-3	100mA compliance (discharge current).
:OUTP ON	Turn on output.
:READ?	Trigger and acquire reading.

4

Ohms Measurements

- **Ohms configuration menu** — Outlines the ohms configuration menu that allows you to set up various ohms measurement aspects.
- **Ohms measurement methods** — Discusses auto and manual ohms measurement methods and how to select them.
- **Ohms sensing** — Covers 2-wire and 4-wire ohms sensing.
- **Offset-compensated ohms** — Describes offset-compensated ohms, which can be used to overcome the effects of offsets when making low-resistance measurements.
- **Ohms source readback** — Covers enabling and disabling ohms source readback.
- **6-wire ohms measurements** — Describes the basic procedure for setting up the SourceMeter for 6-wire ohms measurement, which can be used for measuring resistor networks and hybrid circuits.
- **Remote ohms programming** — Summarizes the basic remote commands required to program the SourceMeter for ohms measurements and gives several typical programming examples.

Ohms configuration menu

NOTE For the Model 2430 Pulse Mode, offset-compensated ohms cannot be enabled from the ohms configuration menu. However, offset-compensated ohms is available as a math function ([Section 8, “Math operations”](#)).

To access the ohms configuration menu, press CONFIG then OHMS. Use [Section 1, “Rules to navigate menus,”](#) to select the various items in the menu tree, which is shown in [Figure 4-1](#). Menu items include:

- SOURCE — Select AUTO or MANUAL source mode.
- SENSE MODE — Select 2-WIRE or 4-WIRE sense mode.
- GUARD — Choose OHMS or CABLE guard.
- OFFSET COMPENSATION — Enable or disable offset-compensated ohms (not valid for Model 2430 Pulse Mode).
- SRC RDBK — Enable or disable source readback mode.

The following paragraphs discuss each of these aspects in detail.

Figure 4-1
Ohms configuration menu tree

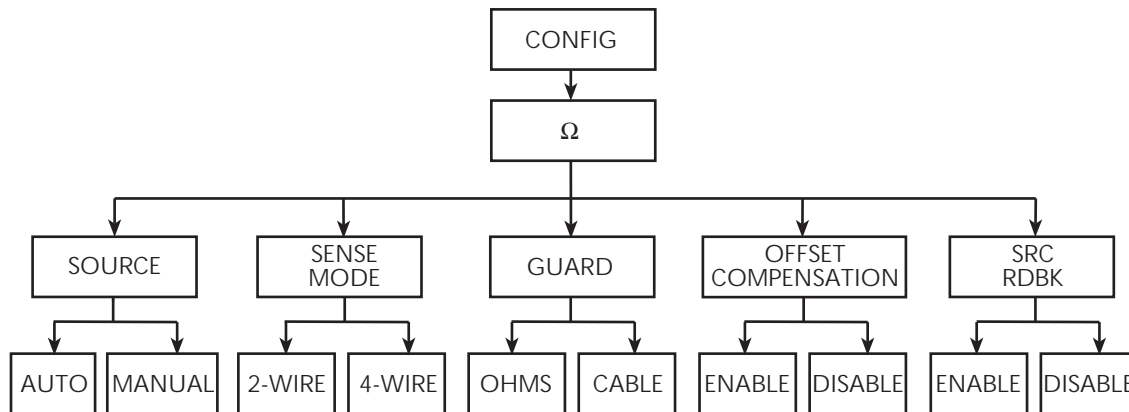

Ohms measurement methods

NOTE For the Model 2430, the following ohms measurement procedures assume that the DC Mode of operation is selected (“Vsrc” or “Isrc” displayed in the source field). If in the Pulse Mode (“Vpls” or “Ipls” displayed), you can select the DC Mode by pressing CONFIG V or I, selecting the SHAPE menu item, and then selecting DC. Pulse Mode operation is covered in [Section 5](#).

There are two methods to measure ohms: auto ohms and manual ohms. When using auto ohms, the SourceMeter operates as a conventional constant-current source ohmmeter or DMM. To use this method, simply select an ohms measurement range (or use autorange), and take the reading from the display. When using auto ohms, the default test current varies with the ohms range, as summarized in [Table 4-1](#).

NOTE You cannot change the test current in the auto ohms mode. If you attempt to change the source current in auto ohms, the SourceMeter will display an error message.

With the manual ohms mode, you can select either source V or source I to make ohms measurements, and the unit will automatically compute the resistance reading using the V/I measurement method. After configuring the desired source and selecting a voltage or current measuring range, select the Ω measurement method to display the calculated V/I ohms reading.

NOTE To achieve optimum accuracy, the SourceMeter measures both V and I and uses these values in ohms calculations (with source readback enabled). The measured source value is more accurate than the programmed source value. For remote operation, the user specifies the functions to measure. See the resistance measurement accuracy specifications in [Appendix A](#).

Table 4-1
Auto ohms default test currents

Auto ohms range	2400, 2400-LV, 2401, and 2410 default test current	2420, 2425, 2430, and 2440 default test current
2Ω	-	1A
20Ω	100mA	100mA
200Ω	10mA	10mA
2kΩ	1mA	1mA
20kΩ	100μA	100μA
200kΩ	10μA	10μA
2MΩ	1μA	10μA
20MΩ	1μA	1μA
200MΩ	100nA	-

Selecting ohms measurement method

On power-up, auto ohms is the default method for the ohms function. Perform the following steps to check and/or change the ohms measurement method:

1. Press CONFIG and then Ω to display the ohms configuration menu.
2. Using the EDIT keys, place the cursor (flashing menu item) on SOURCE and press ENTER.

NOTE *Cursor position indicates the presently selected ohms measurement method. To retain this selection, use the EXIT key to back out of the menu structure and skip the next two steps.*

3. To change the measurement method, place the cursor on the alternate selection (AUTO or MANUAL), and press ENTER.
4. Press EXIT to exit from the menu structure.

Ohms measurement procedure

Perform the following steps to perform auto ohms measurements.

NOTE *The following procedure assumes that the SourceMeter is already connected to the DUT as explained in [Section 2, "Connections."](#)*

WARNING To prevent electric shock, do not make or break connections to the SourceMeter with the output on. If on, press the ON/OFF OUTPUT key to turn the output off.

1. Select ohms measurement function by pressing MEAS Ω
2. Select the ohms measurement method (AUTO or MANUAL).

NOTE Use the manual ohms mode and the V-source method when high-speed settling is required.

3. For manual ohms, configure source.
For manual ohms, you can Source I or Source V at the user-programmed output level. The lowest allowable compliance limit is based on the load and the source value. For example, if sourcing 1V to a 1k Ω resistor, the lowest allowable current compliance is 1mA (1V/1k Ω = 1mA). Setting a limit lower than 1mA will place the source in compliance.
4. Select measurement range.
Use the RANGE keys to select a range appropriate for the expected ohms reading, or use autorange by pressing AUTO. When using manual ranging, selecting the most sensitive (lowest) range provides the best accuracy. Autorange automatically goes to the most sensitive range.
5. Turn output on.
Turn the output on by pressing the ON/OFF OUTPUT key. The OUTPUT indicator will turn on to indicate the output is on.
6. Observe reading on display.
The SourceMeter will go into compliance if you exceed the maximum ohms measurement range.
7. Turn output off.
When finished, turn the output off by pressing the ON/OFF OUTPUT key. The OUTPUT indicator light will turn off.

Ohms sensing

Ohms measurements can be made using either 2-wire or 4-wire sensing. (See [Section 2](#) for information on connections and sensing methods.) Note that resistance measurement accuracy specifications are based on using 4-wire sensing.

The 2-wire sensing method has the advantage of requiring only two test leads. However, as shown in [Figure 4-2](#), test lead resistance can seriously affect the accuracy of 2-wire resistance measurements, particularly with lower resistance values. The 4-wire sensing method shown in [Figure 4-3](#) minimizes or eliminates the effects of lead resistance by measuring the voltage across the resistor under test with a second set of test leads. Because of the high input impedance of the SourceMeter voltmeter, the current through the sense leads is negligible, and the measured voltage is essentially the same as the voltage across the resistor under test.

Figure 4-2
2-wire resistance sensing

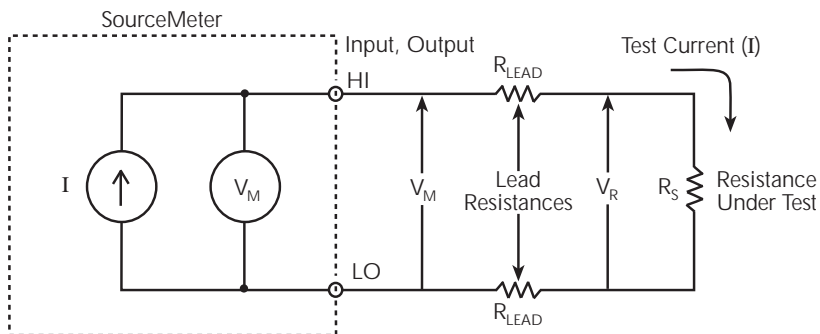

$$\begin{aligned}
 I &= \text{Current sourced by SourceMeter} \\
 V_M &= \text{Voltage measured by SourceMeter} \\
 V_R &= \text{Voltage across resistor} \\
 \text{Measured resistance} &= \frac{V_M}{I} = R_S + (2 \times R_{\text{LEAD}}) \\
 \text{Actual resistance} &= \frac{V_R}{I} = R_S
 \end{aligned}$$

Figure 4-3
4-wire resistance sensing

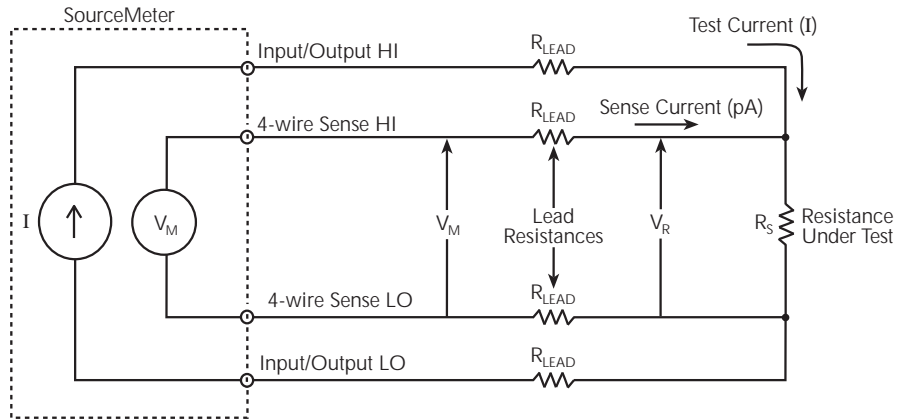

I = Current sourced by SourceMeter
 V_M = Voltage measured by SourceMeter
 V_R = Voltage across resistor

Because sense current is negligible, $V_M = V_R$
 and measured resistance = $\frac{V_M}{I} = \frac{V_R}{I}$

Sense selection

To select sensing mode, press CONFIG then Ω , select SENSE MODE, then choose 2-wire or 4-wire.

Offset-compensated ohms

NOTE For the Model 2430, the following offset-compensated ohms method is not valid in the Pulse Mode. However, offset compensated ohms is available as a math function (Section 8, "Math operations").

The presence of thermal EMFs (V_{EMF}) can adversely affect low-resistance measurement accuracy. To overcome these unwanted offset voltages, use the offset-compensated ohms measurement method.

In general, this method measures resistance (V/I) at a specific source level and then subtracts a resistance measurement made with the source set to zero. With the source set to zero, the source level is V_{EMF} . Thus, the resistance contributed by the presence of V_{EMF} is eliminated.

This two-point measurement method is mathematically expressed as:

Offset-Compensated $\Omega = \Delta V / \Delta I$ where $\Delta V = V_2 - V_1$ and $\Delta I = I_2 - I_1$.

V_1 is the voltage measurement with the source set to a specific level.

V_2 is the voltage measurement with the source set to zero.

I_1 is the current measurement with the source set to a specific level.

I_2 is the current measurement with the source set to zero.

For auto ohms, the SourceMeter will select the appropriate current source level and voltage measurement range. For manual ohms, first select the appropriate source (V or I) value while the output is off. When the source is turned on, the output will cycle between the programmed value and zero (0A or 0V) to derive the offset-compensated ohms measurement.

Enabling/disabling offset-compensated ohms

Offset-compensated ohms is enabled or disabled from the OFFSET COMPENSATION option of the CONFIG OHMS menu.

Ohms accuracy calculations

Example accuracy calculations for various combinations of source readback, offset compensation, and normal/enhanced mode are shown below. See [Appendix A](#) for detailed specifications.

Ohms accuracy of 100mΩ@5mA source current, normal mode

Source readback OFF, Offset Compensation OFF

Ohms accuracy = I_{source} accuracy + V_{meas} accuracy:

$$I \text{ source accuracy} = (5\text{mA}) (0.045\%) + 2\mu\text{A}$$

$$2.25\mu\text{A} + 2\mu\text{A} = 4.25\mu\text{A}$$

$$4.25\mu\text{A} / 5\text{mA} = 0.085\%$$

V_{measure} accuracy for (100mΩ) (5mA) = 500μV:

$$(500\mu\text{V})(0.012\%) + 300\mu\text{V}$$

$$60\text{nV} + 300\mu\text{V} = 300.06\mu\text{V}$$

$$300.06\mu\text{V} / 500\mu\text{V} = 60.01\%$$

Total Ohms Uncertainty

$$60.01\% + 0.085\% = 60.09\%$$

$$100\text{m}\Omega \pm 60.09\% = 39.9\text{m}\Omega \text{ to } 160.09\text{m}\Omega$$

Ohms accuracy of 100mΩ@5mA source current, normal mode

Source Readback ON

Ohms accuracy = I_{meas} accuracy + V_{meas} accuracy:

$$I \text{ measure accuracy} = (5\text{mA}) (0.035\%) + 600\text{nA}$$

$$1.75\mu\text{A} + 600\text{nA} = 2.35\mu\text{A}$$

$$2.35\mu\text{A} / 5\text{mA} = 0.047\%$$

V_{measure} accuracy = (500μV)(0.012%) + 300μV

$$60\text{nV} + 300\mu\text{V} = 300.06\mu\text{V}$$

$$300.06\mu\text{V} / 500\mu\text{V} = 60.01\%$$

Total Ohms uncertainty:

$$60\% + 0.047\% = 60.06\%$$

$$100\text{m}\Omega \pm 60.06\% = 39.94\text{m}\Omega \text{ to } 160.06\text{m}\Omega$$

Ohms accuracy of 100mΩ@ 5mA source current, enhanced mode

Source Readback ON, Offset Compensation ON

Ohms accuracy = [I_{meas} % R_{dg} accuracy + V_{meas} % R_{dg} accuracy] + System noise*

I_{measure} accuracy = (5mA)(0.035%)

1.75μA

Measured system noise: 00.0000mA

1.75μA + 00.0000mA = 1.75μA

1.75μA / 5mA = 0.035%

V_{measure} gain accuracy for (100mΩ) (5mA) = 500μV

(500μV) (0.012%) = 60nV

Measured system noise: 000.002mV

60nV + 2μV = 2.06μV

2.06μV / 500μV = 0.412%

.035% + 0.412% = 0.447%

100mΩ +/- 0.447%

99.55mΩ to 100.44mΩ

*System noise includes the external connection to DUT. To determine system noise, the voltage and current noise is measured with test leads connected to the DUT.

For example, with the 100mΩ resistor connected, the noise voltage was measured by pressing V measure, selecting the appropriate 200mV range, pressing the REL button and making note of the systems noise magnitude. In this example, the measurement was 000.002mV or 2μV.

To measure the current source noise, change the measure function to current measure, select the appropriate current range (in this case, 10mA), press REL and note the system noise magnitude. In the example, the system noise current component was measured as 00.0000mA.

Ohms source readback

NOTE For the Model 2430 Pulse Mode, ohms source readback cannot be enabled.

With ohms source readback enabled, the instrument measures the actual source value instead of the programmed value used for ohms measurements and then uses that measured value for reading calculations. Normally, ohms source readback should be left enabled for optimum ohms measurement accuracy because SourceMeter measurement accuracy is better than source programming accuracy. (See specifications in [Appendix A](#).) However, disabling source readback will allow you to make valid ohms measurements with the source in compliance. See [Section 6](#), “[Source I measure I and source V measure V](#),” for more details.

Ohms source readback selection

Use the following procedure to enable or disable ohms source readback:

1. Press CONFIG then Ω
2. Select SRC RDBK, then press ENTER.
3. Select DISABLE or ENABLE as desired, then press ENTER.
4. Press EXIT to return to normal display.

NOTE Readings in the compliance field will be invalid with source readback disabled.

6-wire ohms measurements

The 6-wire ohms measurement configuration allows you to make accurate resistance measurements on resistor networks and hybrid devices in cases where internal resistance connection nodes are not accessible. The combination of 4-wire Kelvin connections and guarded ohms features eliminates the effects of internal parallel resistances that could degrade measurement accuracy and reduce measurement speed. The basic procedure for setting up the SourceMeter for 6-wire ohms measurements is covered below.

NOTE See [Figure 2-5C](#) for 6-wire ohms connections. See also [Section 2](#), “Ohms guard,” and [Section 6](#), “Guard.”

1. Press CONFIG then Ω to display the CONFIG OHMS menu.
2. Select SENSE MODE, then press ENTER.
3. Select 4-WIRE, then press ENTER.
4. From the CONFIG OHMS menu, select GUARD, then press ENTER.
5. Select OHMS, then press ENTER.
6. Press EXIT to return to normal display.
7. Press MEAS then Ω to select the ohms measurement function.
8. Select the appropriate measurement range, or use autoranging if desired.
9. Turn on the output by pressing the ON/OFF OUTPUT key.
10. Take readings from the display.
11. Turn the output off when done by pressing the ON/OFF OUTPUT key.

Remote ohms programming

The following paragraphs summarize those basic commands necessary for remote ohms programming and also give a programming example for a typical ohms measurement situation.

Remote ohms commands

[Table 4-2](#) summarizes the remote commands for making basic ohms measurements. See [Section 18](#) for more details on these commands.

Table 4-2

Remote commands for basic ohms measurements

Command	Description
:SENSe:FUNction "RESistance"	Select ohms function.
:SENSe:RESistance:RANGe <n>	Select ohms range (n = range).
:SENSe:RESistance:MODE <name>	Select ohms mode (name = MANual or AUTO).
:SENSe:RESistance:OCOMPensated <state>	Enable/disable offset compensation (state = ON or OFF).
:SENSe:VOLTage:PROTection <n>	Set voltage compliance n for manual ohms.
:SENSe:CURREnt:PROTection <n>	Set current compliance n for manual ohms.
:SOURce:FUNction <name>	Select source function (name = VOLTage or CURREnt).
:SYSTem:RSENse <state>	2-wire/4-wire sensing (state = ON, 4-wire; OFF, 2-wire).
:OUTPut <state>	Turn output on or off (state = ON or OFF).
:READ?	Trigger and acquire reading.

Ohms programming example

Table 4-3 summarizes the command sequence for a typical auto ohms measurement. These commands set up the SourceMeter as follows:

- Ohms mode and range: auto, 20k Ω
- Offset compensation: off
- Sense mode: 4-wire

Table 4-3

Auto ohms programming example

Step	Action	Command	Description
1	Select function	*RST FUNC "RES"	Restore GPIB defaults. Select ohms measurement function.
2	Select ohms mode	RES:MODE AUTO	Auto ohms mode.
3	Select range	RES:RANG 20E3 :SYST:RSEN ON :FORM:ELEM RES	Select 20k Ω range. Enable 4-wire sensing. Resistance reading.
4	Output on	:OUTP ON	Turn on output.
5	Get reading	:READ?	Trigger and acquire reading.
6	Output off	:OUTP OFF	Turn off output.

* Numbers correspond to steps in ["Ohms measurement procedure," procedure, page 4-4.](#)

5

Pulse Mode Operation (Model 2430 only)

- **Overview** — Provides a summary of Pulse Mode operation.
- **Pulse characteristics** — Describes the timing characteristics that make up the pulse width and output off-time of the pulse period. Explains how to achieve the fastest pulse output.
- **Pulse energy limitations (10A range)** — Covers pulse energy consumption limitations for the 10A (source or measure) range.
- **Pulse Mode configuration** — Explains how to select and configure the fundamental aspects of Pulse Mode operation.
- **Pulse-measure considerations** — Explains the operational differences between normal (DC Mode) and Pulse Mode operation.

Overview

NOTE The Pulse Mode is only available for the Model 2430. The documentation in this section does not apply to the Models 2400, 2400-LV, 2401, 2410, 2420, 2425, and 2440.

While in the Pulse Mode, the Model 2430 can output one or more pulses. A pulse is formed by turning the output on for a period of time, and then turning the output off (0V or 0A). A single pulse period is shown in [Figure 5-1](#).

The Model 2430 can output current pulses up to 10.5A at 105V or voltage pulses up to 105V at 10.5A. Pulse output polarity can be positive or negative. While in the fixed source mode, the output will alternate between the set pulse level and zero (0V or 0A). When performing a sweep, the output will alternate between each sweep step/point and zero. See [Section 10](#) for details on sweep operation.

A pulse reading is only performed while the output is on. When the output is off (0V or 0A), a reading is not performed. For remote operation, the pulse reading can be disabled.

Auto and manual ohms measurements can be performed while in the Pulse Mode. Also, offset-compensated ohms is available as a math function (FCTN). However, ohms source readback cannot be enabled in Pulse Mode.

Figure 5-1
Pulse period

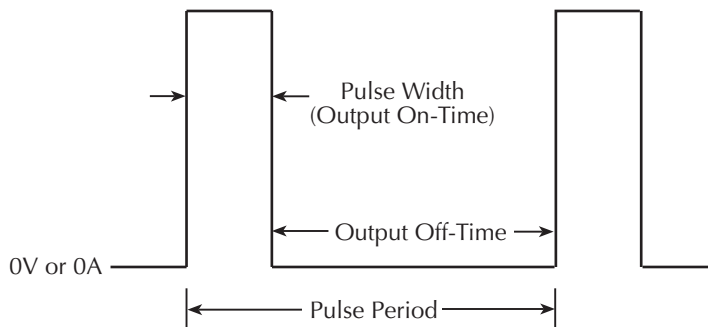

Pulse characteristics

NOTE For the purpose of discussion, positive polarity pulses are shown in the following illustrations. Keep in mind that the Model 2430 can output negative pulses.

As shown in [Figure 5-1](#), a pulse period consists of an output on-time (pulse width) and an output off-time. Depending on how the SourceMeter is configured, the pulse width can be as short as 150µsec or as long as 5msec. With measurement enabled, the output off-time can be as short as 2.9msec or as long as ~10,000sec. The shortest output off time is 1.1msec with measurements disabled. See [Table 5-1](#), "SourceMeter pulse mode timing summary" for details.

[Figure 5-2](#) shows the components that make up the pulse width and the output off-time.

NOTE See the Model 2430 specifications in [Appendix A](#).

Figure 5-2

Pulse-measure timing for default source-measure configuration.

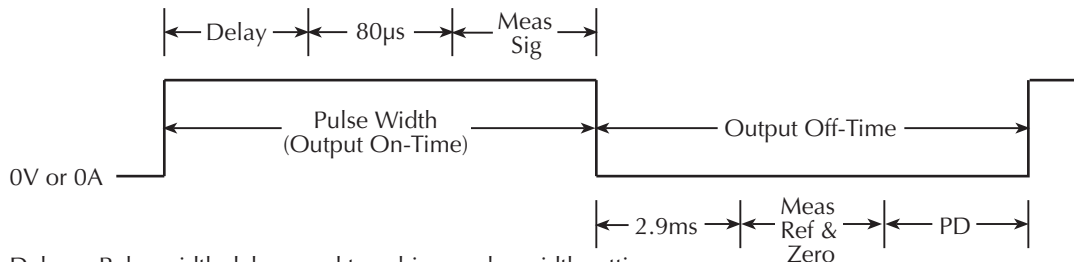

Delay = Pulse width delay, used to achieve pulse width setting.

80µs = Minimum pulse width overhead

Meas Sig = Signal measurement

2.9ms = Minimum output off-time overhead

Meas Ref & Zero = Reference and zero measurement

PD = Pulse delay setting, used to determine time between pulses.

Table 5-1
SourceMeter pulse mode timing summary

Setting ^{1,2}	Minimum Pulse Width (msec)	Maximum Pulse Width (msec)	Minimum Output Off Time (msec)	W/ Display Disabled (msec)
Default source-measure cycle with auto zero on, current range <10A.	0.15	5.0	5.0	4.0
Source-Measure cycle with auto zero off, current range <10A.	0.15	5.0	2.9	1.9
Source only, current range <10A.	0.15	5.0	2.9	1.9
Source-Measure cycle with autozero on, current range set to 10A.	0.15	2.5	5.0	4.0
Source-Measure cycle with autozero off, current range set to 10A.	0.15	2.5	2.90	1.9
Source only, current range set to 10A.	0.15	2.5	2.90	1.9

¹ Pulse delay is set to zero for all settings.

² For consistent pulse period, duty cycle should not exceed 8%

Note: Minimum output off time assumes minimum pulse width setting.

Pulse width

The pulse width can be set from 0.15msec to 5.00msec. However, depending on how the SourceMeter is configured, the pulse width setting may not be achievable. For example, if it takes 1.667msec to perform the signal measurement, the minimum pulse width that can be achieved is 1.75msec (1.667msec signal measurement plus 80µsec overhead). Therefore, if the pulse width setting is shorter than what is achievable, the setting is ignored.

The maximum pulse width for the 10A range (source or measure) is 2.5msec. If the setting is >2.5msec, the SourceMeter will limit the pulse width to 2.5msec.

Signal measurement

A pulse reading consists of three measurement conversions. The signal (pulse) is measured, a precise internal reference is measured, and finally, zero (common) is measured. The reading is calculated from these measurements.

As shown in [Figure 5-2](#), the signal measurement (Meas Sig) is a component of the pulse width, while the reference and zero measurements (Meas Ref & Zero) are components of the off-time. The measurement process is split up this way to allow the shortest possible pulse width. The time to perform the signal measurement depends on the speed setting (NPLC) of the SourceMeter and the power line frequency:

$$\text{Meas Sig} = \text{NPLC} / \text{Line Frequency}$$

Where: Meas Sig is the time it takes to measure the signal.

NPLC is the present speed setting (0.004 to 0.100 PLC).

Line Frequency is the frequency of the power line (50 or 60 Hz).

NOTE For front panel operation, the menu to set speed is displayed by pressing the SPEED key. For remote operation, speed is set using an :NPLCycles command. See [Section 7](#), "Speed," for details.

Overhead time

As shown in [Figure 5-2](#), there is some pulse width overhead time that is inherent to the measurement process. The 80µsec is the minimum overhead times that can be achieved. If the SourceMeter is configured to perform additional operations (e.g., math calculations, relative, store, sweep), this time will be higher.

Pulse width delay

When the pulse width setting is greater than the sum of the signal measurement and overhead times, a delay is used to achieve the desired pulse width. This delay is automatically calculated by the instrument using the following equation:

$$\text{Pulse Width Delay} = \text{PW} - \text{Sig Meas} - 80\mu\text{sec}$$

Where: PW is the pulse width setting

Sig Meas is the signal measurement time

80µsec is the minimum pulse width overhead time

For example, assume the pulse width setting is 1msec, and the signal measurement time is 167µsec. For the 80µsec overhead time, the pulse width delay is 753µsec:

$$\text{Pulse Width Delay} = 1\text{msec} - 167\mu\text{sec} - 80\mu\text{sec} = 753\mu\text{sec}$$

NOTE If the result of the pulse width delay calculation is a negative number, pulse width delay is set to 0sec. A negative number indicates that the pulse width setting is too short (not achievable).

Output off-time

Reference and zero measurements

As previously explained in “Pulse width,” “Signal measurement,” the reference and zero measurements for a pulse reading are performed during the output off-time of the pulse period (Figure 5-2). The time to perform these two measurements depends on the speed setting (NPLC) of the SourceMeter and the power line frequency:

$$\text{Meas Ref \& Zero} = 2 \times \text{NPLC} / \text{Line Frequency}$$

Where: Meas Ref & Zero is the time it takes to measure the reference and zero.
NPLC is the present speed setting (0.004 to 0.1 PLC).
Line Frequency is the frequency of the power line (50 or 60 Hz).

Overhead time

As shown in Figure 5-2, there is some overhead time that is inherent to the source-measure process. The 2.9msec is the minimum overhead time for a source-measure cycle that can be achieved during the output off-time. The minimum output off-time may vary depending on instrument settings (see Table 5-1 on page 5-4 for details). If the SourceMeter is configured to perform additional operations (e.g., math calculations, relative, store, sweep), this time will be higher.

Pulse delay

The pulse delay (PD) is set by the user. It can be set from 0 to 9999.999sec. The total output off time is the addition of the pulse delay, auto zero measurement time, and the minimum output off time of the instrument.

Pulse duty cycle

Duty Cycle is the percentage of time during the pulse period that the output is on. It is calculated as follows:

$$\text{Duty Cycle} = \text{Pulse Width} / (\text{Pulse Width} + \text{Off-time})$$

For example, if the pulse width is 1msec and the off-time is 9msec, the duty cycle is calculated as follows:

$$\begin{aligned}
 \text{Duty Cycle} &= 1\text{msec} / (1\text{msec} + 9\text{msec}) \\
 &= 1\text{msec} / 10\text{msec} \\
 &= 0.10 \\
 &= 10\%
 \end{aligned}$$

Based on the possible output on/off times that can be configured, the pulse duty cycle can range from <1% to 83.5%.

NOTE *Pulse Duty Cycle on the 10A range should be limited to 8% for consistent pulses. Please see “Pulse energy limitations (10A range),” page 5-9.*

Fast pulse output

The fastest pulses are achieved by configuring the SourceMeter for the shortest pulse width and shortest output off-time. This is accomplished by setting the measurement speed to 0.004 PLC, setting the pulse delay to 0sec, disabling auto zero, and making sure that no other operations (i.e., relative, math calculations, store, sweep) are being performed. Please see [Table 5-1](#) for details.

Auto zero

The output off-time can be reduced by disabling auto zero. With auto zero disabled, only the signal is measured. As shown in [Figure 5-3](#), the reference and zero measurements (which normally are part of the off-time) are not performed. Also note that the minimum overhead time that occurs during the off-time is reduced to 2.9msec. Therefore, with pulse delay set to 0sec, the output off-time can be as short as 2.9msec.

Figure 5-3
Pulse-measure timing (auto zero off)

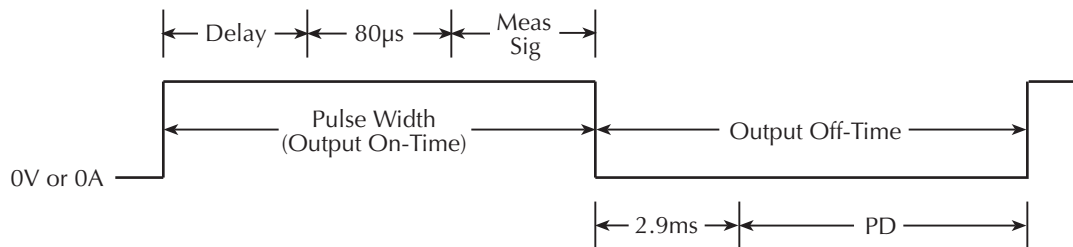

Delay = Pulse width delay, used to achieve pulse width setting.

80µs = Minimum pulse width overhead

Meas Sig = Signal measurement

1.4ms = Minimum output off-time overhead

PD = Pulse delay setting, used to determine time between pulses.

NOTE With auto zero disabled, zero drift will eventually corrupt the accuracy of the pulse measurement. To re-establish an accurate pulse measurement, enable auto zero or change the speed setting.

NOTE From the front panel, auto zero is controlled from the A/D CONTROLS item of the Main Menu. For remote operation, the :SYSTEM:AZERo command controls auto zero.

Pulse-only

The fastest pulses are achieved by disabling measurements. With the signal not measured, as shown in Figure 5-4, the pulse width can be as short as the 150µsec overhead. With reference and zero not measured, and display disabled, the output off-time can be as short as the 1.9msec overhead.

NOTE Measurements cannot be disabled from the front panel. For remote operation, measurements can be disabled by sending the [SENSE]:FUNCTION:OFF:ALL command. See Section 18 for details. To disable the display from the front panel, press CONFIG then EDIT, then select NOW.

Figure 5-4
Pulse-only timing

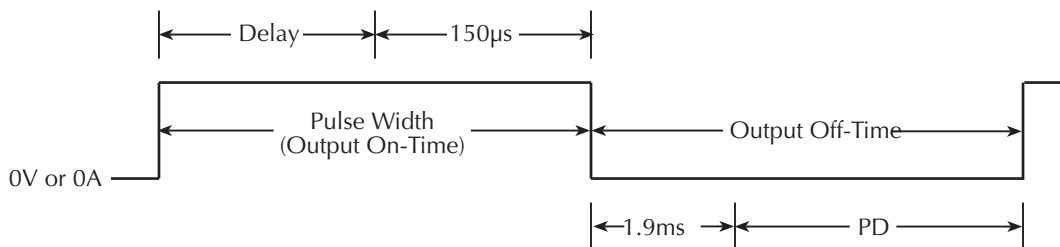

Delay = Pulse width delay, used to achieve pulse width setting.
150µs = Minimum pulse width overhead

1.90ms = Minimum output off-time overhead
PD = Pulse delay setting, used to determine time between pulses.

Pulse jitter

Pulse jitter is defined as the variance in the configured pulse on and off times. The amount of jitter that can occur depends on how the SourceMeter is set up. For the least amount of jitter (<5µsec for pulse on-time), turn off the display. See Section 1, “Disabling front panel display.” With the display on, pulse on-time jitter depends on the pulse width. For pulses <1msec wide, on-time jitter can be up to 20µsec. For pulses >1msec wide, on-time jitter is 5–40µsec.

Jitter for pulse off-time can be as high as 1msec, depending on the integration rate, auto zero, and on-time. In general, the higher the off-time, the higher the jitter.

Pulse energy limitations (10A range)

Energy for pulses are provided by an internal bank of capacitors. Each pulse consumes energy from the capacitors. After a pulse is generated, the capacitors begin to recharge. The next pulse will occur at the configured time as long as the capacitors have had enough time to recharge. If the capacitors are not charged enough to provide the pulse, the instrument will wait until the necessary charge energy is available.

Charge energy consumption by a pulse depends on the pulse current and pulse width, and is expressed as follows:

$$Q = I \times t$$

Where: Q is the charge energy consumed by the pulse

I is the pulse current

t is the output on-time (pulse width)

From the above equation, high current and/or long output on-time results in high energy consumption, and therefore, longer charge time for the capacitors.

On all but the 10A range (source or measure), charge energy consumption is low enough to allow the capacitors to recharge before the next pulse is due. This fast recharge process allows the configured pulse period to be consistent (jitter free).

On the 10A range (source or measure), the configured pulse period will be consistent as long as the pulse duty cycle is 8% or less. Above 8%, the capacitors will not be able to recharge sufficiently before the next pulse is due. As a result, the pulse period becomes longer (due to additional charge time between pulses) and more inconsistent (jitter).

To achieve a consistent pulse period on the 10A range, set a pulse off-time that will provide a duty cycle that does not exceed 8%. For example, if the pulse width is 2msec, the required off-time is calculated as follows:

$$\begin{aligned} \text{Pulse Off-time} &= (\text{Pulse Width} / \text{Duty Cycle}) - \text{Pulse Width} \\ &= (2\text{msec} / 8\%) - 2\text{msec} \\ &= 25\text{msec} - 2\text{msec} \\ &= 23\text{msec} \end{aligned}$$

If a consistent pulse period is not required for your test, the 10A range allows you to output fast, high energy (>8% duty cycle) pulses. With the pulse delay set to 0sec, each subsequent pulse will output as soon as the capacitors become sufficiently charged.

Pulse Mode configuration

Front panel Pulse Mode configuration

Select Pulse Mode, and set pulse width and pulse delay

1. Press CONFIG then SOURCE V or I.
2. Select SHAPE from the displayed choices, then press ENTER.
3. Select PULSE from the displayed choices, then press ENTER. Selecting the Pulse Mode enables the pulse width and pulse delay items of the menu.
4. Select PULSE WIDTH from the displayed choices, then press ENTER.
5. Enter the desired pulsewidth value (0.15ms to 5.00ms), then press ENTER. Note that the pulse width internally will limit to 2.5ms on the 10A range (source or measure).
6. Select DELAY from the displayed choices, then press ENTER.
7. Enter the desired pulse delay value (0 to 9999.99872 sec), then press ENTER.
8. Press EXIT to return to the normal display.

Set pulse measurement speed

Once the Pulse Mode is selected, the available NPLC values become accessible to set pulse measurement speed.

1. Press SPEED to display the pulse speed menu.
2. Select the speed setting (0.004 to 0.100) and press ENTER.

Set pulse count

The arm count and trigger count determine how many pulses will be sourced. In general, the number of pulses to be sourced is the product of the arm count and trigger count. For example, if the arm count is two and the trigger count is five, ten pulses will be sourced when the output is turned on. However, with the arm count set to infinite, the Model 2430 will continuously source pulses when the output is turned on. Note that the product of finite value counts cannot exceed 2500. See [Section 11, "Trigger models,"](#) for details.

Perform the following steps to set the arm count:

1. Press CONFIG and then TRIG to display the trigger configuration menu.
2. Select ARM LAYER from the displayed choices and press ENTER.
3. Select COUNT from the displayed choices and press ENTER.

4. For continuous pulse output, select INFINITE, press ENTER and proceed to step 6. Otherwise, select FINITE, press ENTER and proceed to the next step to set the arm count.
5. Enter the desired arm count value and press ENTER.
6. Use the EXIT key to back out of the menu.

Perform the following steps to set the trigger count:

1. Press CONFIG and then TRIG to display the trigger configuration menu.
2. Select TRIG LAYER from the displayed choices and press ENTER.
3. Select COUNT from the displayed choices and press ENTER.
4. Enter the desired trigger count value and press ENTER.
5. Use the EXIT key to back out of the menu.

Disable/enable auto zero

Pulse speed can be increased by disabling auto zero. However, zero drift will eventually corrupt the accuracy of the pulse measurement. To re-establish an accurate pulse measurement, enable auto zero or change the speed setting.

1. Press MENU to display the main menu.
2. Select A/D CTRL from the displayed choices and press ENTER.
3. Select AUTO ZERO from the displayed choices and press ENTER.
4. Select DISABLE or ENABLE and press ENTER.
5. Use the EXIT key to back out of the menu.

Remote command Pulse Mode configuration

For remote operation, the commands to select and configure the Pulse Mode are provided in [Table 18-6](#). and [Table 18-7](#).

Pulse-measure considerations

Measurement speed

Measurement speed for the Pulse Mode can be set from 0.004 to 0.100 PLC. If the speed setting while in the DC Mode is >0.10 PLC, it will change to 0.004 when the Pulse Mode is selected. If the speed setting is <0.10 PLC, that setting will be retained when the Pulse Mode is selected. If the Pulse Mode speed setting is <0.01, it will change to 0.01 when the DC Mode is selected.

For remote operation, the parameter value for the [:SENSE] ... :NPLC commands is limited to a maximum value of 0.10. Details are provided in [Section 7](#), “Speed.”

Filter

Filtering cannot be used while the Model 2430 is in the Pulse Mode. You can configure the filter, but you cannot enable it. Pressing the FILTER key displays the “Invalid in Pulse Mode!” message. For remote operation, the [:SENSe]:AVERage[:STATe] command (which is used to enable the filter) causes error +831: Invalid in Pulse Mode.

Auto range

Measurement auto range cannot be used (enabled) while in the Pulse Mode. Pressing the AUTO range key displays the “Invalid in Pulse Mode!” message. For remote operation, the [:SENSe] ... :RANGE:AUTO commands (which are used to enable/disable auto range) cause error +831: Invalid in Pulse Mode.

Concurrent measurements

For remote operation, more than one function can be measured simultaneously while in the DC Mode. However, in the Pulse Mode, only one function can be measured for each pulse. The [:SENSe]:FUNctioN:CONcurreNt command (which enables/disables concurrent measurements) causes error +831: Invalid in Pulse Mode. The [:SENSe]:FUNctioN[:ON]:ALL command will select the ohms function. See [Section 18](#), “SENSe1 subsystem” - “Select measurement functions,” for details on concurrent measurements.

Ohms source readback

For DC Mode operation, ohms source readback can be enabled. The instrument measures the actual source value for ohms measurement and then uses that

measured value for the reading calculation. For the Pulse Mode, ohms source readback cannot be enabled. [Section 4](#) covers “[Ohms source readback](#).”

NOTE Make sure that the source is not in compliance when taking pulse-ohms readings.

Toggle key

For the DC Mode, the TOGGLE key manipulates display readings while the output is on. For the Pulse Mode, the output is only on for very short periods of time (pulse width). Therefore, the TOGGLE key is disabled in the Pulse Mode.

Offset-compensated ohms

From the front panel there are two methods to perform offset-compensated ohms measurements. For one method, which is enabled from the CONFIG OHMS menu, the 2-point measurement process is performed at a user-set source level, and at 0V or 0A. This method is not available while in the Pulse Mode. The other method, which is a math function (FCTN), the user sets both source levels for the 2-point measurement process. This method is valid in the Pulse Mode. See [Section 8](#), “[Math operations](#),” for details.

For remote operation, offset-compensated ohms, as a math function (:CALCulate1 subsystem), can be performed in the Pulse Mode. From the :SENSe subsystem, offset-compensated ohms cannot be performed. The [:SENSe]:RESistance:OCOMpensated command (which enables/disables offset-compensated ohms) causes error +831: Invalid in Pulse Mode.

Source delay

In the DC Mode, the source delay is a delay that occurs between the source and measure operations. The delay period can be manually set or auto delay can be used. With auto delay, the delay is automatically set according to function and range. See [Section 3](#), “[Operation considerations](#),” and “[Source delay](#),” for details.

For the Pulse Mode, source delay is not used. For front panel operation, the menu items to set source DELAY and select AUTO DELAY are replaced by menu items to set pulse DELAY and PULSE WIDTH when the Pulse Mode is selected. Therefore, you cannot set source delay while in the Pulse Mode.

For remote operation, you can set the source delay, however the setting will be ignored in the Pulse Mode. The ignored commands for source delay include :SOURce:DELay <n> and :SOURce:DELay:AUTO .

Trigger delay

In the DC Mode, the trigger delay is a user set delay that occurs between the trigger and pulse operations. In the Pulse Mode, trigger delay is not used. You can set the trigger delay while in the Pulse Mode, but it will not be used until you go back into the DC Mode. See [Section 11](#) for details on triggering. For remote operation, the delay set by `:TRIGger:DElay <n>` is ignored in the Pulse Mode.

Input triggers

In the DC Mode, you can enable the source, delay or measure input event detectors. See [Section 11](#) for details on triggering.

In the pulse mode, you can enable the source, delay, or measure input event detectors. However, these event detectors do not correlate to source, delay, and measure actions as in DC mode. In pulse mode, all three event detectors occur prior to the pulse action. Please refer to [“Pulse Mode triggering \(Model 2430\),” page 11-20](#) for more details.

Output triggers

In the DC Mode, you can configure the SourceMeter to output a trigger after the source, delay and/or measure operation. See [Section 11](#) for details on triggering.

In pulse mode, you can enable the source, delay, and/or measure output triggers. The source and delay triggers occur consecutively at the start of the pulse output. This was synchronized beginning with firmware revision C27. Prior to this revision, the source and delay output triggers would occur before the source action. In all firmware revisions, the measure output trigger occurs after the pulse action has been completed. Please refer to [“Pulse Mode triggering \(Model 2430\),” page 11-20](#) for more details.

Auto output-off

For the DC Mode, with auto output-off enabled, the output will turn on at the beginning of each SDM cycle and turn off after each measurement is completed. See [Section 13](#), [“Output-off states,”](#) for details on auto output-off.

While in the Pulse Mode, auto output-off is always enabled. For remote operation, you can send the `:SOURce:CLEAr:AUTO OFF` command to disable auto output-off, but it will be ignored.

Output-off state

In the Pulse Mode, the normal output-off is used. You cannot select one of the other modes while in Pulse Mode. For remote operation, the :OUTPut[1]:SMODE <name> command (which is used to select the output-off state), causes error +831: Invalid in Pulse Mode. See [Section 13](#), “Output-off states,” for details.

Turning source on

For remote Pulse Mode operation, an :INITiate command is used to start the pulse output process. The :READ? command will send :INITiate to start the pulse process, and it will also acquire the pulse readings. The :INITiate command by itself will start the pulse process, but it will not acquire any pulse readings. (If you use :INITiate to start the pulse process, you should then use :FETCh? to acquire readings.) The pulse process can be stopped at any time by sending the :ABORt command.

Sending :OUTPut[1]:STATe] ON will also send :INITiate to start the pulse process. Note however, that you cannot use :OUTPut[1]:STATe] OFF to abort the pulse output process.

SCPI signal oriented measurement commands

The :CONFIgure:<function> and :MEASure[:<function>]? commands are invalid and cause error +831: Invalid in Pulse Mode. These commands are documented in [Section 17](#).

6

Source-Measure Concepts

- **Compliance limit** — Discusses compliance limit including real and range compliances, maximum compliance values, and how to determine compliance limit.
- **Overheating protection** — Provides information on preventing SourceMeter overheating, including power equations.
- **Source-delay-measure cycle** — Describes the various phases of the source-delay-measure cycle as well as sweep waveforms.
- **Operating boundaries** — Covers voltage and current operating boundaries for source and sink operation, I-source and V-source, and source-measure modes.
- **Basic circuit configurations** — Covers basic circuit configurations for source I, source V, and measure only operating modes.
- **Guard** — Covers cable guard, ohms guard, and guard sense.
- **Data flow** — Describes measurement readings, math, rel, and limits operation, and how data is stored in the buffer.

Compliance limit

When sourcing voltage, the SourceMeter can be set to limit current. Conversely, when sourcing current, the SourceMeter can be set to limit voltage. The SourceMeter output will not exceed the compliance limit.

2400/2400-LV/2401 — Current limit can be set from 1nA to 1.05A, and the voltage limit can be set from 200 μ V to 210V (21V for 2400-LV and 2401).

2410 — Current limit can be set from 1nA to 1.05A, and the voltage limit can be set from 200 μ V to 1.1kV.

2420 — Current limit can be set from 10nA to 3.15A, and the voltage limit can be set from 200 μ V to 63V.

2425 and 2430 DC Mode — Current limit can be set from 10nA to 3.15A, and the voltage limit can be set from 200 μ V to 105V.

2430 Pulse Mode — Current limit can be set from 10nA to 10.5A, and the voltage limit can be set from 200 μ V to 105V.

2440 — Current limit can be set from 10nA to 5.25A, and the voltage limit can be set from 200 μ V to 42V.

NOTE For the following discussion, “measurement range” refers to the measurement function that is the opposite of the source function. When sourcing voltage, the current measurement range is the point of discussion. Conversely, when sourcing current, the voltage measurement range is the point of discussion.

Types of compliance

There are two types of compliance: “real” and “range.” Depending upon which value is lower, the output will clamp at either the displayed compliance setting (real compliance) or at the maximum possible compliance value for the fixed measurement range (range compliance). This clamping action effectively limits the power that can be delivered to the device. When the SourceMeter is acting as a current source, the voltage is clamped at the compliance value; conversely, the current is clamped at the compliance value when the SourceMeter is acting as a voltage source. Note that range compliance cannot occur if the AUTO measurement range is selected. Thus, to avoid range compliance, use AUTO range.

NOTE For the Model 2430, AUTO range is not valid in the Pulse Mode.

When in real compliance, the source clamps at the displayed compliance value. For example, if the compliance voltage is set to 1V and the measurement range is 2V, output voltage will clamp at 1V. In this case, the “CMPL” annunciator will flash.

When in range compliance, the source output clamps at the maximum compliance value for the fixed measurement range (not the compliance value). For example, if compliance is set to 1V and the measurement range is 200mV, output voltage will clamp at 210mV. In this situation, the units in the compliance display field will flash. For example, with the following display: Vcml: 10mA, the "mA" units indication will flash.

Maximum compliance values

The maximum compliance values for the measurement ranges are summarized in [Table 6-1](#).

Table 6-1
Compliance limits

2400/2400-LV/2401		2410		2420	
Measure range	Maximum compliance value	Measure range	Maximum compliance value	Measure range	Maximum compliance value
200mV 2V 20V 200V*	±210mV ±2.1V ±21V ±210V	200mV 2V 20V 1000V	±210mV ±2.1V ±21V ±1.1kV	200mV 2V 20V 60V	±210mV ±2.1V ±21V ±63V
1µA 10µA 100µA 1mA 10mA 100mA 1A	±1.05µA ±10.5µA ±105µA ±1.05mA ±10.5mA ±105mA ±1.05A	1µA 10µA 100µA 1mA 20mA 100mA 1A	±1.05µA ±10.5µA ±105µA ±1.05mA ±21mA ±105mA ±1.05A	10µA 100µA 1mA 10mA 100mA 1A 3A	±10.5µA ±105µA ±1.05mA ±10.5mA ±105mA ±1.05A ±3.15A

Table 6-1 (cont.)
Compliance limits

2425/2430		2440	
Measure range	Maximum compliance value	Measure range	Maximum compliance value
200mV	±210mV	200mV	±210mV
2V	±2.1V	2V	±2.1V
20V	±21V	10V	±10.5V
100V	±105V	40V	±42V
10µA	±10.5µA	10µA	±10.5µA
100µA	±105µA	100µA	±105µA
1mA	±1.05mA	1mA	±1.05mA
10mA	±10.5mA	10mA	±10.5mA
100mA	±105mA	100mA	±105mA
1A	±1.05A	1A	±1.05A
3A/10A	**	5A	±5.25A

* 2400 only

** ±3.15A (2425 and 2430 DC mode)

±10.5A (Pulse mode; 2430 only)

Compliance examples

When the SourceMeter goes into real compliance, the Cmpl label for the compliance display will flash. When the SourceMeter goes into range compliance, the units label ("mA") will flash instead. For the following examples, labels in boldface type indicate that they are flashing.

Measurement Range: 100mA

Compliance Setting: **Cmpl**: 075.000 mA Flashing Cmpl indicates that real compliance has occurred. The output is clamped at 75mA.

Measurement Range: 10µA

Compliance Setting: Cmpl: 075.000 **µA** Flashing mA indicates that range compliance has occurred. The output is clamped at 10.5µA.

Determining compliance limit

Table 6-2 provides examples (Model 2400) for determining the actual compliance limit. For the first three entries in the table, the compliance setting is 150V. On the 200V measurement range, the actual compliance is 150V (compliance setting <

measure range = real compliance). On the 20V and 200mV measurement ranges, compliance is 21V and 210mV, respectively (measure range < compliance setting = range compliance). The same rules apply for the next three entries for current compliance.

Table 6-2

Compliance examples

Compliance setting		Measurement range		Actual compliance	
Display message	Setting	Display message	Range	Value	Type
Cmpl: 0.15000kV	150V	---.---V	200V	150V	Real
Cmpl: 0.15000kV	150V	--.----V	20V	21V	Range
Cmpl: 0.15000kV	150V	---.---mV	200mV	210mV	Range
Cmpl: 075.000 mA	75mA	---.---mA	100mA	75mA	Real
Cmpl: 075.000 mA	75mA	--.----mA	10mA	10.5mA	Range
Cmpl: 075.000 mA	75mA	-.-----mA	1mA	1.05mA	Range

Overheating protection

Proper ventilation is required to keep the SourceMeter from overheating. See “**WARNING - CAUTION**” located at the beginning of [Section 3](#) for details on maintaining proper ventilation.

The SourceMeter has an over-temperature protection circuit that will turn the output off in the event that the SourceMeter overheats. If the output trips due to overheating, a message indicating this condition will be displayed. You will not be able to turn the output back on until the SourceMeter cools down.

NOTE Models 2420, 2425, 2430, and 2440 — The cooling fan will run at high speed while in the overheated state.

CAUTION Models 2420, 2425, 2430, and 2440 — If, after 90 seconds, the SourceMeter is still overheated, the “**OVER-TEMP FAILURE!!!**” message may appear. In that event, turn off the SourceMeter immediately and allow it to cool for 30 minutes.

With the SourceMeter off, check all the cooling vents to make sure they are not blocked. DO NOT touch the heat sink as it may be hot enough to cause burns.

After turning the SourceMeter back on, verify that the cooling fan is running. If the failure message persists, contact Keithley to facilitate repairs. Leaving the SourceMeter on with the failure message displayed may result in damage to the unit.

Overheating conditions

Assuming proper ventilation is maintained, the SourceMeter will not overheat (and subsequently turn off the output) when the SourceMeter is operating as a source (not sink) and the ambient temperature is $\leq 30^{\circ}\text{C}$.

Above 30°C , for both source and sink operation, the SourceMeter will not overheat if the high power range(s) is not used. For the Models 2400 and 2410, the high power range is 1A. For the Model 2420, the high power ranges are 20V, 3A and 60V, 1A. For the Model 2425 and Model 2430 DC Mode, the high power ranges are 20V, 3A and 100V, 1A. For the Model 2440, the high power ranges are 10V, 5A and 40V, 1A.

NOTE See “[Operating boundaries](#)” for details on source and sink operation.

Source-delay-measure cycle

In addition to static source and/or measure operation, SourceMeter operation can consist of a series of source-delay-measure (SDM) cycles (Figure 6-1). During each SDM cycle, the following occurs:

1. Set the source output level.
2. Wait for the source delay.
3. Make the measurement.

NOTE For the Model 2430 Pulse Mode, source delay is not used. The delays used for Pulse Mode are covered in Section 5.

See Section 11 for details on how the SDM cycle relates to the trigger model.

Figure 6-1
Source-delay-measure (SDM) cycle

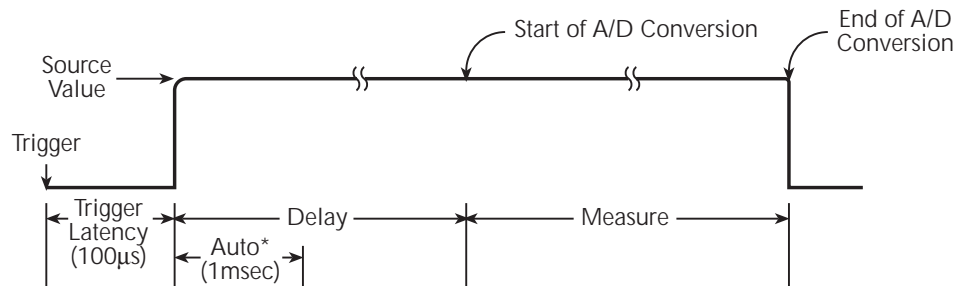

* If enabled

The delay phase of the SDM cycle allows the source to settle before the measurement is performed. The delay period depends on how the source delay is configured. The source delay can be manually set from 0000.00000 seconds to 9999.9990 seconds. If using auto delay, the delay depends on which source range is presently selected, as summarized in Table 3-4; see Section 3 for details.

The manually set delay (up to 9999.999 sec) is available to compensate for longer settling required by external circuitry. The more capacitance seen at the output, the more settling time is required for the source. The actual delay period needed can be calculated or determined by trial and error. For purely resistive loads and at higher current levels, the programmable delay can be set to 0msec.

The measure time depends on the selected measurement speed. For example, if speed is set at 0.01 PLC (power line cycles), the measure time would be $167\mu\text{sec}$ for 60Hz operation ($0.01/60$).

Sweep waveforms

There are four basic sweep types to select from: linear staircase, logarithmic staircase, custom, and source memory. Three of the sweeps are shown in [Figure 6-2](#).

Figure 6-2
Three basic sweep waveform types

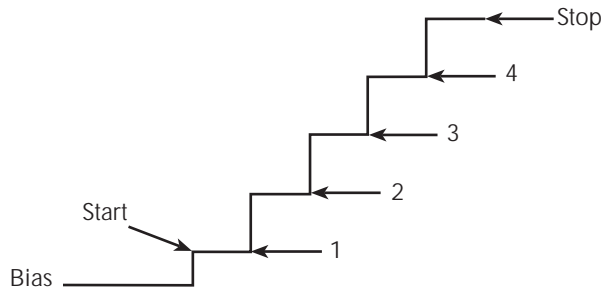

A. Linear Staircase Sweep

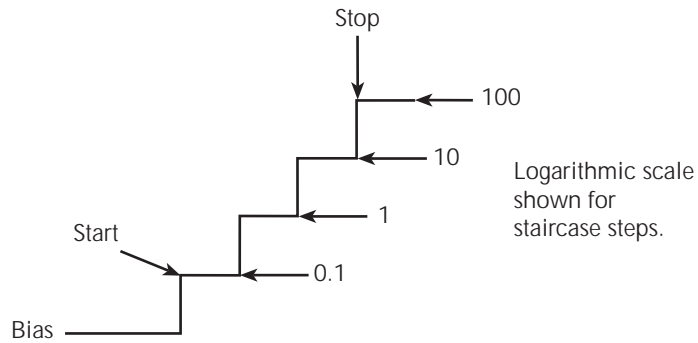

B. Logarithmic Staircase Sweep

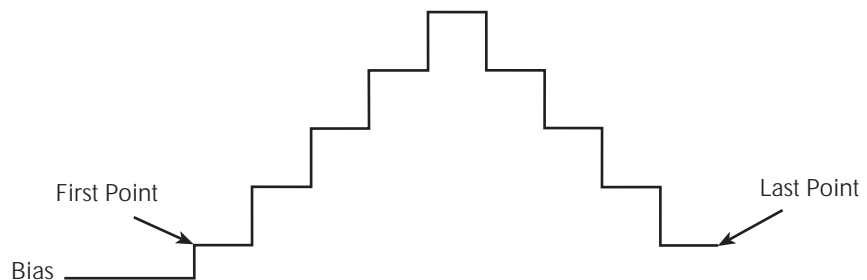

C. Custom Sweep

Operating boundaries

Source or sink

Depending on how it is programmed and what is connected to the output (load or source), the SourceMeter can operate in any of the four quadrants. The four quadrants of operation for the SourceMeter models are shown in [Figure 6-3](#) through [Figure 6-7](#). When operating in the first (I) or third (III) quadrant, the SourceMeter is operating as a source (V and I have the same polarity). As a source, the SourceMeter is delivering power to a load.

When operating in the second (II) or fourth (IV) quadrant, the SourceMeter is operating as a sink (V and I have opposite polarity). As a sink, it is dissipating power rather than sourcing it. See [Section 3](#), “[Remote command measure only](#),” for more information.

Duty cycle

The duty cycle is the ratio of source on time to total time period expressed as a percentage. For example, if the source is on for six out of 10 seconds, the duty cycle is 60%.

Model 2400/2400-LV/2401 SourceMeter

The general operating boundaries for the Model 2400/2400-LV/2401 are shown in [Figure 6-3](#). In this drawing, the 1A, 20V and 100mA, 200V magnitudes are nominal values. The actual maximum output magnitudes of the SourceMeter are 1.05A, 21V and 105mA, 210V (21V for 2400-LV and 2401). Also note that the boundaries are not drawn to scale.

These operating boundaries are valid only if the SourceMeter is being operated in an environment where the ambient temperature is 30°C or less.

NOTE Above 30°C, high power operation could overheat the SourceMeter, causing the output to turn off. See “[Overheating protection](#),” [page 6-6](#) for details.

The heavy solid lines show the limits for continuous output operation. Note that in quadrants II and IV (sink operation), the limits for the 1A range are derated as follows:

1A Range – Limits linearly derated from: -1A, 20V to -0.6A, 20V
1A, -20V to 0.6A, -20V

If the output duty cycle is decreased to 60% or less, sink operation limits are restored to normal as shown by the dotted lines in [Figure 6-3](#).

Model 2410 and 2420 SourceMeter

The general operating boundaries for the Model 2410 and Model 2420 are shown in [Figure 6-4](#) and [Figure 6-5](#).

Figure 6-3

Model 2400/2400-LV/2401 operating boundaries ($T_{amb} 30^{\circ}\text{C}$)

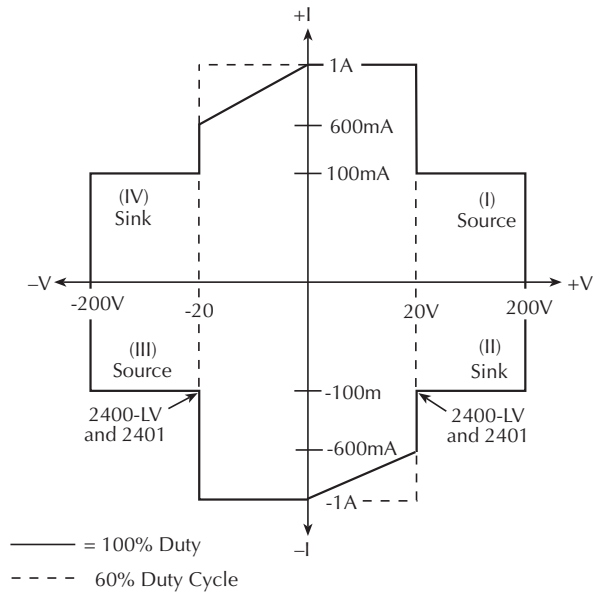

Figure 6-4
Model 2410 operating boundaries ($T_{amb} 30^{\circ}\text{C}$)

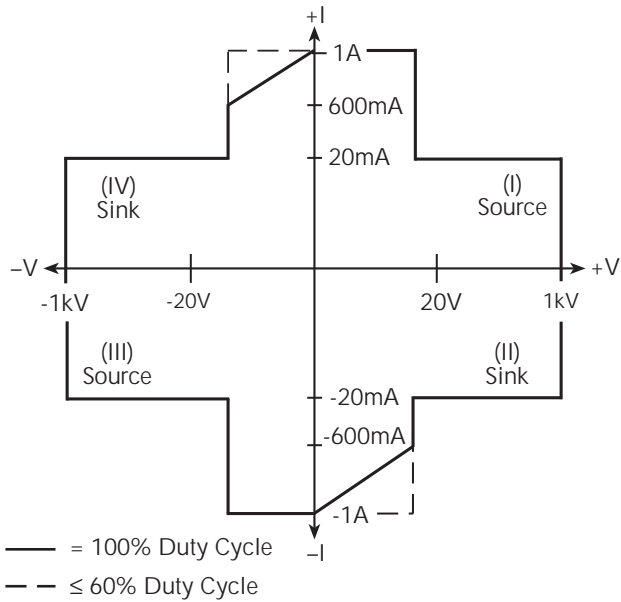
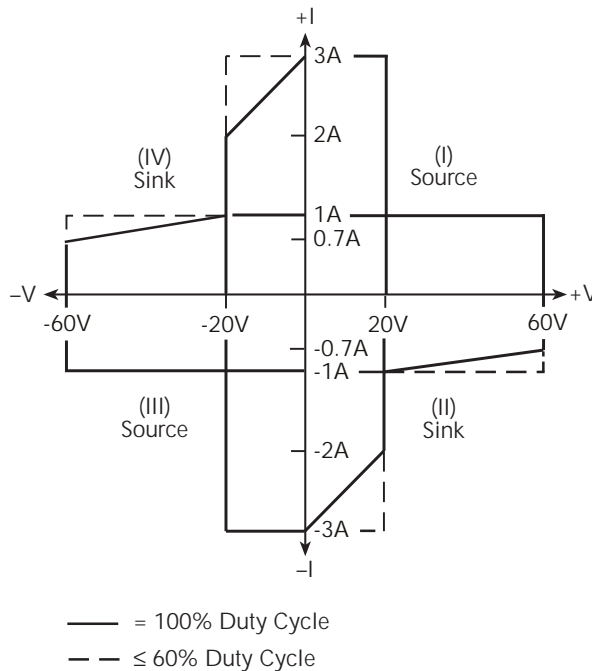

Figure 6-5
Model 2420 operating boundaries ($T_{amb} 30^{\circ}\text{C}$)



Models 2425 and 2430 SourceMeters

The general operating boundaries for the Models 2425 and 2430 are shown in [Figure 6-6](#). The boundaries for the Model 2425 and Model 2430 DC Mode are shown in [Figure 6-6A](#), and the boundaries for the Model 2430 Pulse Mode are shown in [Figure 6-6B](#).

Model 2425 and Model 2430 DC Mode

In [Figure 6-6A](#) for the Model 2425 and Model 2430 DC Mode, the 3A, 20V and 1A, 100V magnitudes are nominal values. The actual maximum output magnitudes of the SourceMeter are 3.15A, 21V and 1.05A, 105V.

Model 2430 Pulse Mode

In [Figure 6-6B](#) for the Model 2430 Pulse Mode, the 10A and 100V magnitudes are nominal values. The actual maximum output magnitudes of the SourceMeter are 10.5A and 105V.

Figure 6-6
Model 2425/2430 operating boundaries ($T_{amb} 30^{\circ}C$)

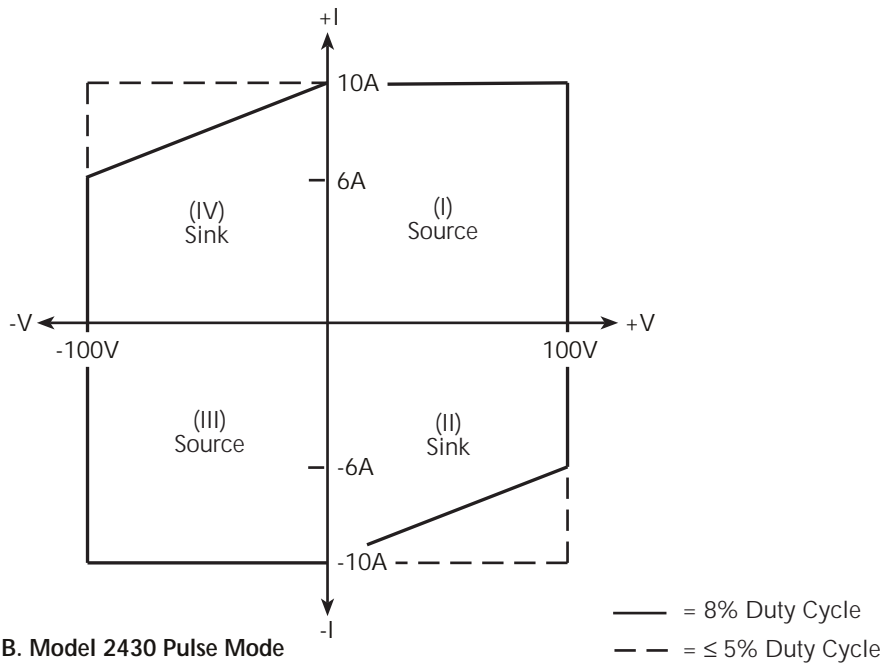
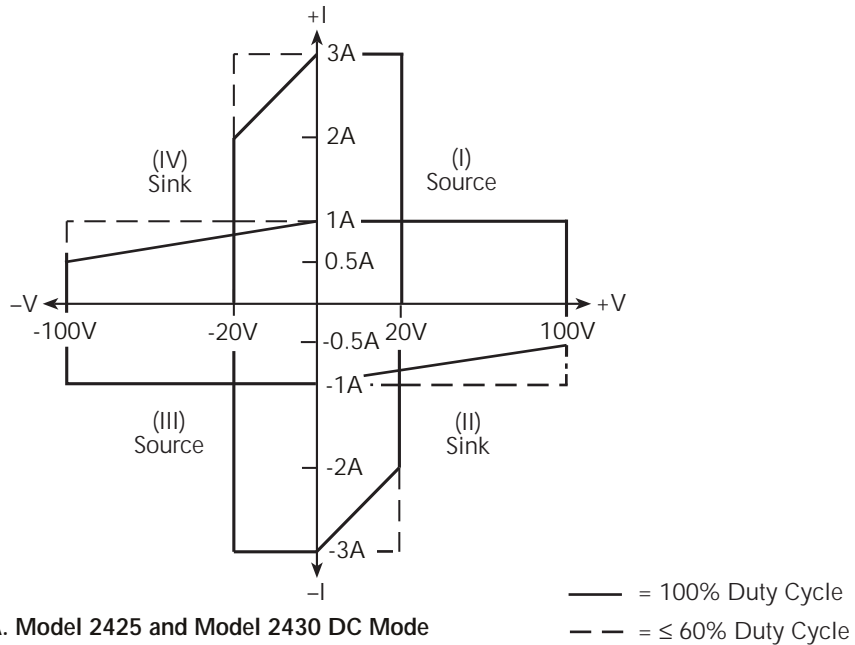

Model 2440 SourceMeter

The general operating boundaries for the Model 2440 are shown in [Figure 6-7](#).

Figure 6-7

Model 2440 operating boundaries ($T_{amb} \leq 30^{\circ}\text{C}$)

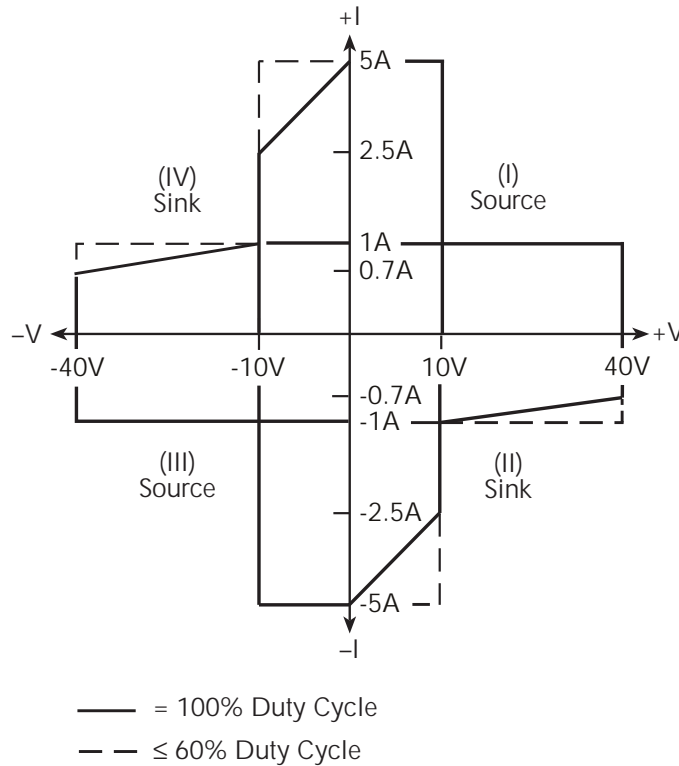

I-Source operating boundaries

[Figure 6-8](#) and [Figure 6-9](#) show the operating boundaries for the I-Source. Only the first quadrant of operation is covered. Operation in the other three quadrants is similar.

Figure 6-8
I-Source output characteristics

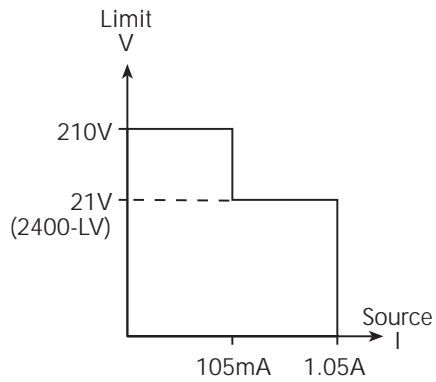

A. Model 2400/2400-LV

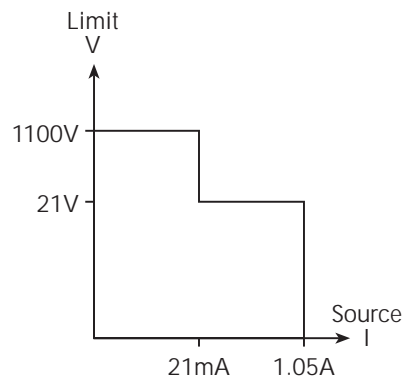

B. Model 2410

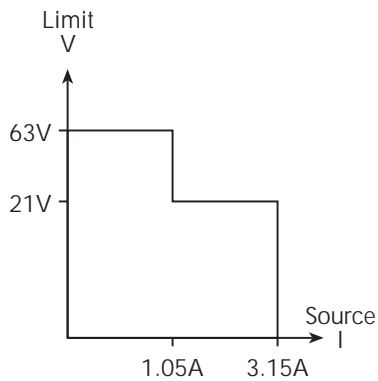

C. Model 2420

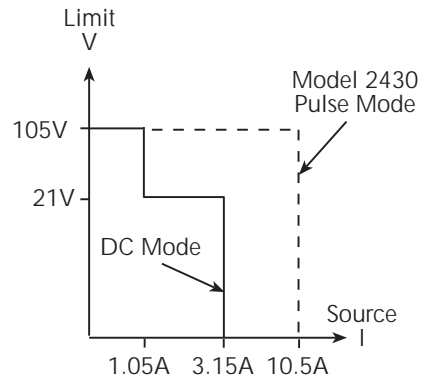

D. Models 2425 and 2430

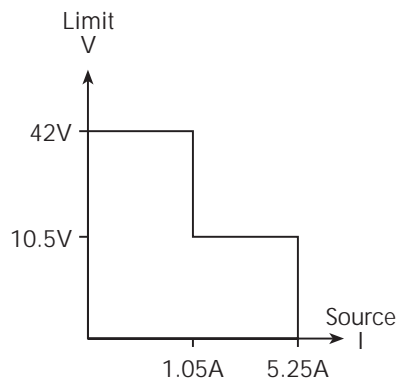

E. Model 2440

Figure 6-9 shows the limit lines for the I-Source. The current source limit line represents the maximum source value possible for the presently selected current source range. For example, if on the 100mA current source range, the current source limit line is at 105mA. The voltage compliance limit line represents the actual compliance that is in effect. Remember that compliance can be real or range (see “Compliance limit,” page 6-2). These limit lines are boundaries that represent the operating limits of the SourceMeter for this quadrant of operation. The operating point can be anywhere inside (or on) these limit lines. The limit line boundaries for the other quadrants are similar.

Figure 6-9
I-Source limit lines

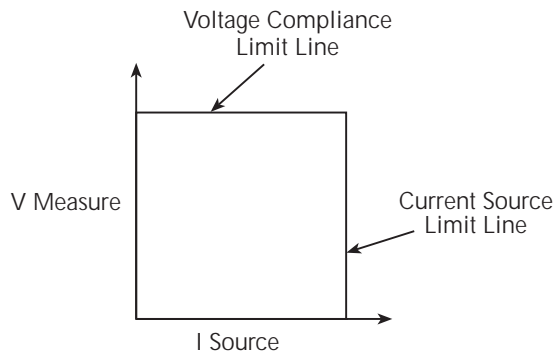

Voltage compliance boundaries

Where within the boundaries the SourceMeter operates depends on the load (DUT) that is connected to its output. Figure 6-10 shows operation examples for resistive loads that are 200Ω and 800Ω, respectively. For these examples, the SourceMeter is programmed to source 100mA and limit 40V. (See Section 3, “Basic source-measure procedure.”)

In Figure 6-10A, the SourceMeter is sourcing 100mA to the 200Ω load and subsequently measures 20V. As shown, the load line for 200Ω intersects the 100mA current source line at 20V.

Figure 6-10B shows what happens if the resistance of the load is increased to 800Ω. The DUT load line for 800Ω intersects the voltage compliance limit line placing the SourceMeter in compliance. In compliance, the SourceMeter will not be able to source its programmed current (100mA). For the 800Ω DUT, the SourceMeter will only output 50mA (at the 40V limit).

Notice that as resistance increases, the slope of the DUT load line increases. As resistance approaches infinity (open output), the SourceMeter will source virtually 0mA at 40V. Conversely, as resistance decreases, the slope of the DUT load line

decreases. At zero resistance (shorted output), the SourceMeter will source 100mA at virtually 0V. Regardless of the load, voltage will never exceed the programmed compliance of 40V.

Figure 6-10

I-Source operating examples

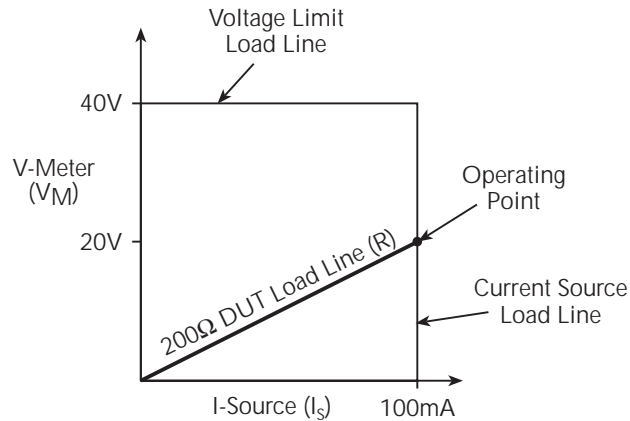

$$\begin{aligned} V_M &= I_S \cdot R \\ &= (100\text{mA}) (200\Omega) \\ &= 20\text{V} \end{aligned}$$

A. Normal I-Source Operation

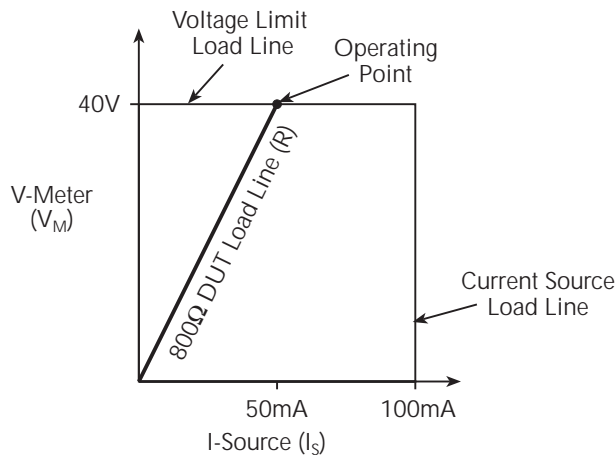

$$\begin{aligned} I_S &= V_M / R \\ &= 40\text{V} / 800\Omega \\ &= 50\text{mA} \end{aligned}$$

B. I-Source In Compliance

V-Source operating boundaries

Figure 6-11 and Figure 6-12 show the operating boundaries for the V-Source. Only the first quadrant of operation is covered. Operation in the other three quadrants is similar.

Figure 6-11
V-Source output characteristics

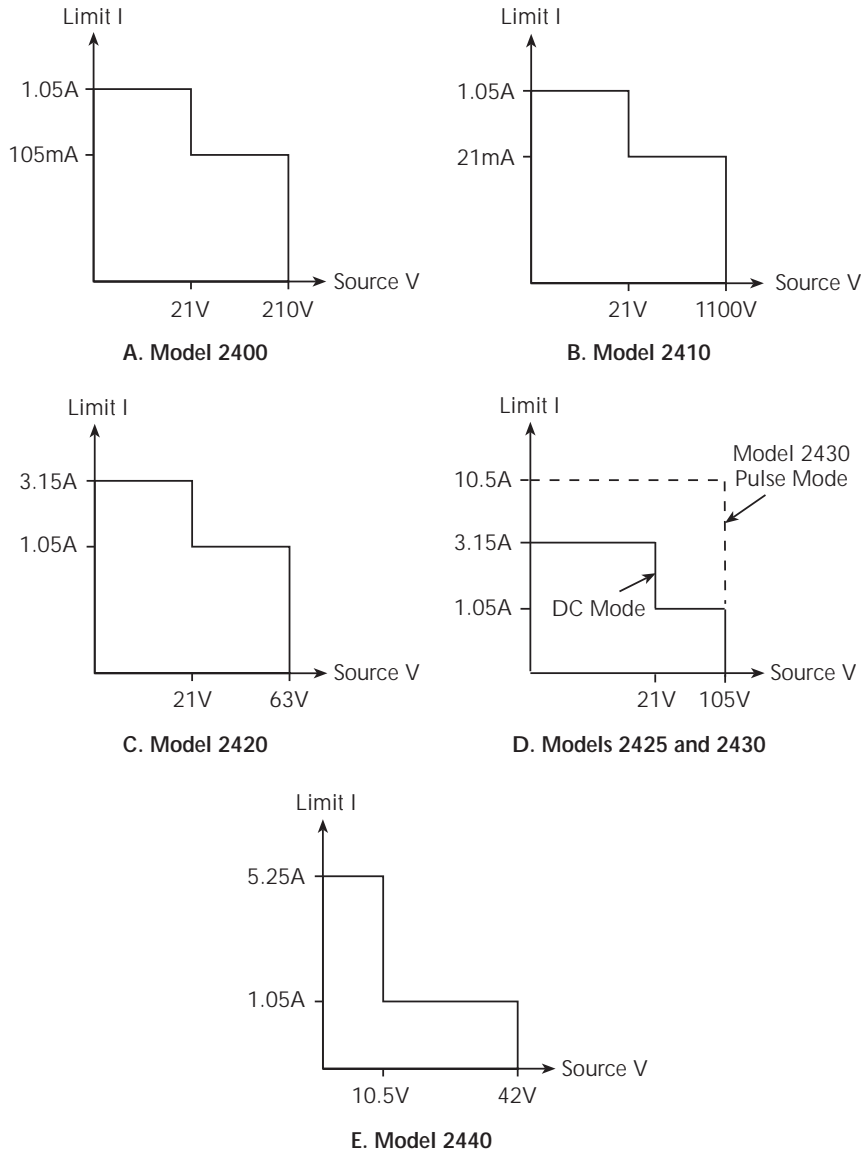
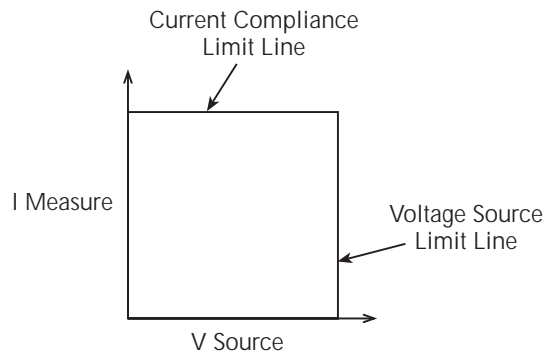

Figure 6-12 shows the limit lines for the V-Source. The voltage source limit line represents the maximum source value possible for the presently selected voltage source range. For example, if on the 20V source range, the voltage source limit line is at 21V. The current compliance limit line represents the actual compliance in effect. Remember that compliance can be real or range. (See “Compliance limit,” page 6-2.) These limit lines are boundaries that represent the operating limits of the SourceMeter for this quadrant of operation. The operating point can be anywhere inside (or on) these limit lines. The limit line boundaries for the other quadrants are similar.

Figure 6-12
V-Source limit lines



Current compliance boundaries

Where within the boundaries the SourceMeter operates depends on the load (DUT) that is connected to the output. Figure 6-13 shows operation examples for resistive loads that are $2\text{k}\Omega$ and 800Ω respectively. For these examples, the SourceMeter is programmed to source 50V and limit 50mA.

In Figure 6-13A, the SourceMeter is sourcing 100V to the $2\text{k}\Omega$ load and subsequently measures 25mA. As shown, the load line for $2\text{k}\Omega$ intersects the 50V voltage source line at 25mA.

Figure 6-13B shows what happens if the resistance of the load is decreased to 800Ω . The DUT load line for 800Ω intersects the current compliance limit line placing the SourceMeter in compliance. In compliance, the SourceMeter will not be able to source its programmed voltage (50V). For the 800Ω DUT, the SourceMeter will only output 40V (at the 50mA limit).

Notice that as resistance decreases, the slope of the DUT load line increases. As resistance approaches infinity (open output), the SourceMeter will source virtually 50V at 0mA. Conversely, as resistance increases, the slope of the DUT load line decreases. At zero resistance (shorted output), the SourceMeter will source virtu-

ally 0V at 50mA. Regardless of the load, current will never exceed the programmed compliance of 50mA.

Figure 6-13
V-Source operating examples

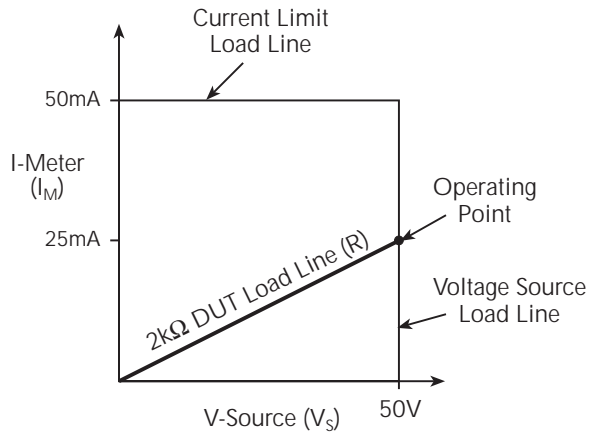

$$\begin{aligned} I_M &= V_S / R \\ &= 50V / 2k\Omega \\ &= 25mA \end{aligned}$$

A. Normal V-source operation

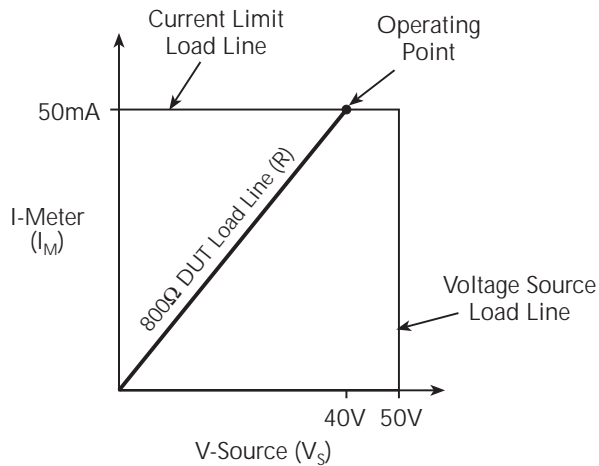

$$\begin{aligned} V_S &= I_M \cdot R \\ &= (50mA) (800\Omega) \\ &= 40V \end{aligned}$$

B. V-Source in compliance

Source I measure I and source V measure V

The SourceMeter can measure the function it is sourcing. When sourcing a voltage, you can measure voltage. Conversely, if you are sourcing current, you can measure the output current. For these measure source operations, the measure range is the same as the source range.

This feature is valuable when operating with the source in compliance. When in compliance, the programmed source value is not reached. Thus, measuring the source lets you measure the actual output voltage. With the use of the TOGGLE key, you can display the measurement of any two of the three functions (volts, amps, and ohms) concurrently. For remote operation, you can measure all three functions concurrently. (See [Section 17](#) and [Section 18](#).)

Source readback accuracy

SourceMeter measurement accuracy is better than sourcing accuracy (see the source and measure specifications in [Appendix A](#)). For that reason, select the same measurement and source functions, then use the measured value instead of the programmed source value for optimum accuracy.

Basic circuit configurations

Source I

When configured to source current (I-Source) as shown in [Figure 6-14](#), the SourceMeter functions as a high-impedance current source with voltage limit capability and can measure current (I-Meter) or voltage (V-Meter).

For voltage measurements, the sense selection (2-wire local or 4-wire remote) determines where the measurement is made. In local sense, voltage is measured at the Input/Output terminals of the SourceMeter.

In 4-wire remote sense, voltage can be measured directly at the DUT using the Sense terminals. This eliminates any voltage drops that may be in the test leads or connections between the SourceMeter and the DUT.

NOTE The current source does not require or use the sense leads to enhance current source accuracy.

With 4-wire remote sensing selected, the sense leads must be connected or incorrect operation will result. Over-voltage protection (OVP) can be used if the potential for sense lead disconnection exists (see [Section 3](#), “V-source protection”).

Figure 6-14
Source I

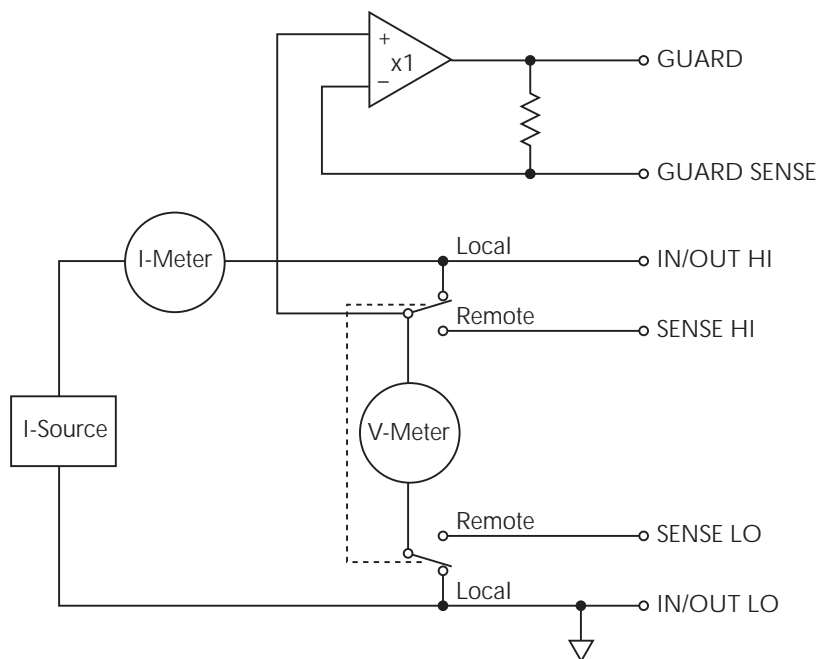

Source V

When configured to source voltage (V-Source) as shown in [Figure 6-15](#), the SourceMeter functions as a low-impedance voltage source with current limit capability and can measure current (I-Meter) or voltage (V-Meter).

Sense circuitry is used to continuously monitor the output voltage and make adjustments to the V-Source as needed. The V-Meter senses the voltage at the Input/Output terminals (2-wire local sense) or at the DUT (4-wire remote sense using the sense terminals) and compares it to the programmed voltage level. If the sensed level and the programmed value are not the same, the V-Source is adjusted accordingly. Remote sense eliminates the effect of voltage drops in the test leads ensuring that the exact programmed voltage appears at the DUT.

NOTE The voltage error feedback to the V-Source is an analog function. The source error amplifier is used to compensate for IR drop in the test leads.

Figure 6-15
Source V

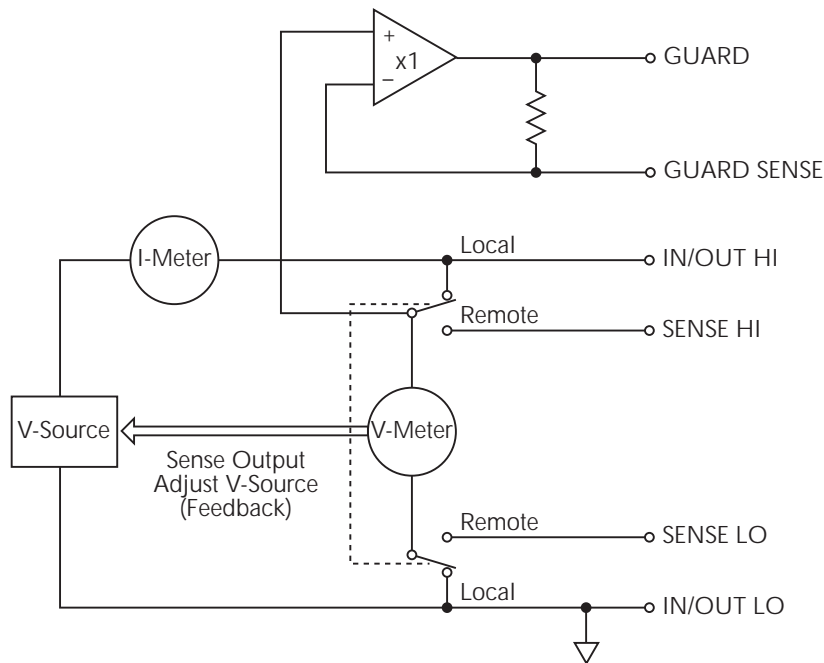

Measure only (V or I)

Figure 6-16 shows the configurations for using the SourceMeter exclusively as a voltmeter or ammeter. As shown in Figure 6-16A, the SourceMeter is configured to measure voltage only by setting it to source 0A and measure voltage.

CAUTION V-Compliance must be set to a level that is higher than the measured voltage. Otherwise, excessive current will flow into the SourceMeter. This current could damage the SourceMeter. Also, when connecting an external voltage to the I-Source, set the output-off state to the high-impedance mode. (See Section 13, “Output-off states.”)

In Figure 6-16B, the SourceMeter is configured to measure current-only by setting it to source 0V and measure current. Note that in order to obtain positive (+) readings, conventional current must flow from IN/OUT HI to LO.

Figure 6-16
Measure only (V or I)

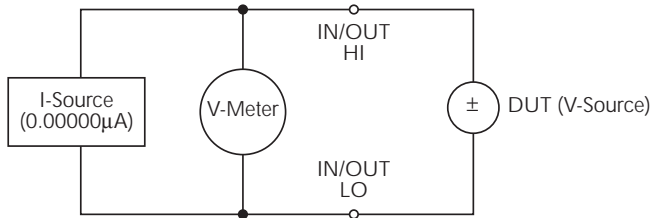

A. Measure Voltage Only

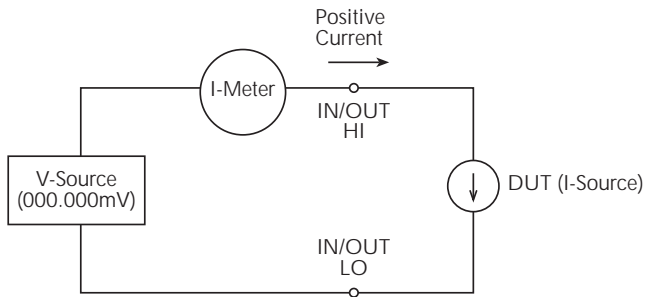

Note: Positive current flowing out of IN/OUT HI results in positive (+) measurements.

B. Measure Current Only

Note: Use 2-wire local sensing.

Guard

WARNING **GUARD is at the same potential as output HI. Thus, if hazardous voltages are present at output HI, they are also present at the GUARD terminal.**

NOTE See [Section 2, “Guarding methods,”](#) for details on guarded test connections as well as information on selecting guard modes.

For 6-wire ohms guard measurements, use the GUARD output-off state. For details on the GUARD output-off state, see [Section 13, “Output-off states.”](#)

The driven guard (available at the rear panel GUARD terminal) is always enabled and provides a buffered voltage that is at the same level as the Input/Output HI (or Sense HI for remote sense) voltage. The purpose of guarding is to eliminate the effects of leakage current (and capacitance) that can exist between input/output high and low. In the absence of a driven guard, leakage in the external test circuit could be high enough to adversely affect the performance of the SourceMeter.

Leakage current can occur through parasitic or non-parasitic leakage paths. An example of parasitic resistance is the leakage path across the insulator in a coax or triax cable. An example of non-parasitic resistance is the leakage path through a resistor that is connected in parallel to the DUT.

There are two programmable output impedance levels for the guard output. The high-impedance ($\sim 10\text{k}\Omega$) CABLE guard is used to reduce the effects of capacitance and leakage current paths in the test circuit. The low-impedance ($< 1\Omega$) OHMS guard is used to cancel the effects of parallel resistances when measuring a resistor element of a resistor network.

Cable guard

The CABLE guard selection provides a high-impedance ($\sim 10\text{k}\Omega$) driven guard to prevent positive feedback, which could cause oscillations when using shielded cables. Cable guard is used to drive the shields of cables and test fixtures. Guard is extended to a test fixture using a safety banana plug (such as the Model 8008-BAN). Inside the test fixture, the guard can be connected to a guard plate or shield that surrounds the DUT.

WARNING To prevent injury or death, a safety shield must be used to prevent physical contact with a guard plate or guard shield that is at a hazardous potential ($>30V_{rms}$ or 42.4V peak). This safety shield must completely enclose the guard plate or shield and must be connected to safety earth ground. [Figure 6-17B](#) shows the metal case of a test fixture being used as a safety shield.

Inside the test fixture, a triaxial cable can be used to extend guard to the DUT. The center conductor of the cable is used for In/Out HI, the inner shield is used for guard, and the outer shield is used for In/Out LO and is connected to the safety shield (which is connected to safety earth ground).

A coaxial cable can be used if the guard potential does not exceed $30V_{rms}$ (42.4V peak). The center conductor is used for In/Out HI, and the outer shield is used for guard. For higher guard potentials, use a triaxial cable as previously explained.

[Figure 6-17](#) shows how cable guard can eliminate leakage current through the insulators in a test fixture. In [Figure 6-17A](#), leakage current (I_L) flows through the insulators (R_{L1} and R_{L2}) to In/Out LO, adversely affecting the low-current (or high-resistance) measurement of the DUT.

In [Figure 6-17B](#), the driven guard is connected to the metal guard plate for the insulators. Since the voltage on either end of R_{L1} is the same (0V drop), no current can flow through the leakage resistance path. Thus, the SourceMeter only measures the current through the DUT.

Cable guard should be used when sourcing or measuring low current ($<1\mu A$).

NOTE When using shielded, triaxial, or coaxial cabling with guard, the CABLE guard setting must be used to prevent oscillations. CABLE guard is the factory default setting.

Ohms guard

The OHMS guard selection provides a low-impedance ($<1\Omega$), high current (up to 50mA) driven guard. This lets you perform in-circuit ohms measurements of the DUT where other parallel resistive paths are present. These measurements are typically performed in Delta or Wye configurations.

NOTE Ohms guard is not available for the 1A, 3A, and 5A (2420, 2425, 2430, and 2440) ranges (source and measure). Ohms guard cannot be selected if already on range. Conversely, if ohms guard is already selected, the 1A, 3A, and 5A (2420, 2425, 2430, and 2440) ranges cannot be selected. See also [Section 4](#), “6-wire ohms measurements,” and [Section 2](#), “Ohms guard.”

If you want to measure the resistance of a single resistor in the network, you must use the ohms guard configuration. [Figure 6-18B](#) shows how to measure the resistance of R1. Since the voltage on either side of R2 is the same, no current can flow through it. Thus, all the programmed current (I_M) from the SourceMeter will flow through R1. The voltage across R1 is then measured, and an accurate resistance measurement is calculated, in this case 20k Ω .

NOTE *Guard current (I_G) must not exceed 50mA. If it does, the guard voltage drops lower than the output voltage allowing leakage current. Thus, the guarded ohms measurement becomes corrupted.*

Figure 6-17
High-impedance measurements

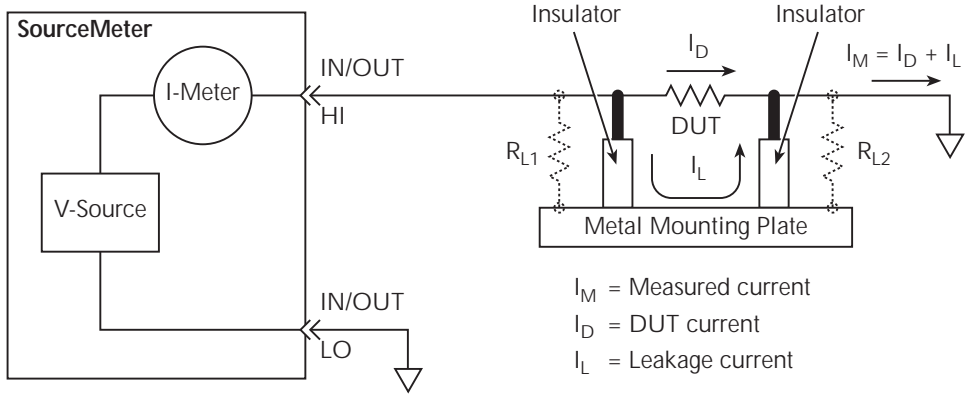

A. Unguarded

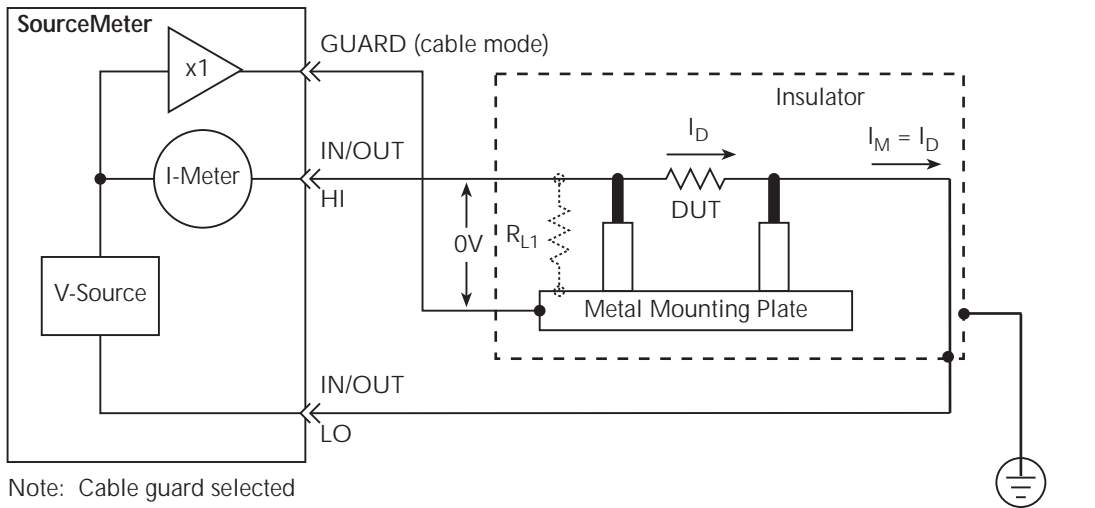

B. Guarded

Connect to earth safety ground using #18 AWG wire or larger.

Figure 6-18
In-circuit ohms measurements

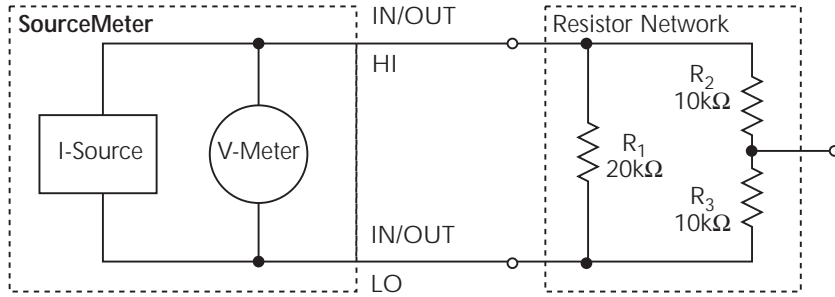

A. Unguarded

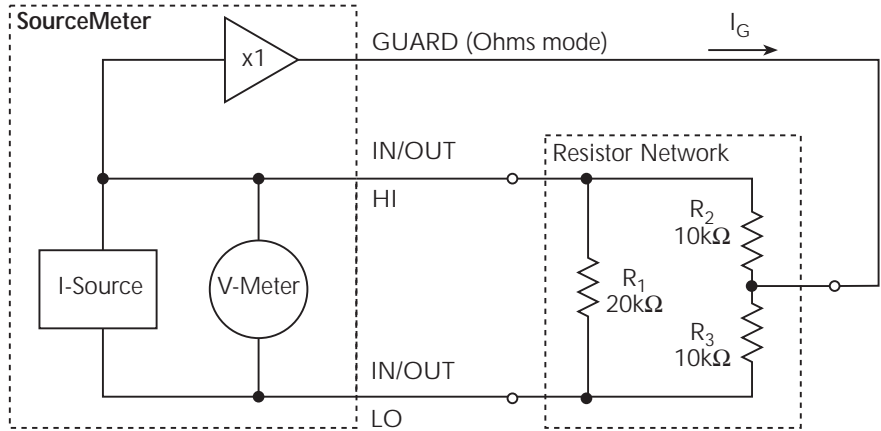

Note: Ohms guard selected

B. Guarded

$$I_G = \frac{V_M}{R_3}$$

Guard sense

When the GUARD-to-LO resistance path is less than $1\text{k}\Omega$, remote guard sensing should be used to compensate for IR drop in the GUARD test lead and/or switch contacts on a switching card.

Figure 6-18 was modified to create Figure 6-19A by changing the value of R3 to 100Ω and showing the 1Ω resistance (R_{TL}) of the GUARD test lead. Since the resistance path from GUARD-to-LO is less than $1\text{k}\Omega$, the IR drop in the guard test lead (R_{TL}) becomes significant. The guard voltage applied to the bottom of R2 is now significantly lower than the In/Out HI voltage of the SourceMeter. As a result, leakage current (I_L) flows through R2, adversely affecting the resistance measurement of R1.

The guard test lead IR drop is compensated for by connecting GUARD SENSE as shown in Figure 6-19B. Sensing allows the guard voltage to be sensed (measured) at the resistor network for better guard voltage regulation. If the remotely sensed guard voltage is less than the output voltage of the SourceMeter, the guard voltage will be increased until the sensed guard voltage equals the output HI voltage.

Note that in order to ensure that guard current (I_G) in Figure 6-19 does not exceed 50mA , output voltage from the SourceMeter must not exceed 5V ($50\text{mA} \times 100\Omega = 5\text{V}$).

NOTE *Guard sense operation is automatic. There is no menu selection to enable or disable guard sense.*

For 6-wire ohms guard measurements, use the GUARD output-off state. For details on the GUARD output-off state, see Section 13, "Output-off states."

Figure 6-19
In-circuit ohms measurements using guard sense

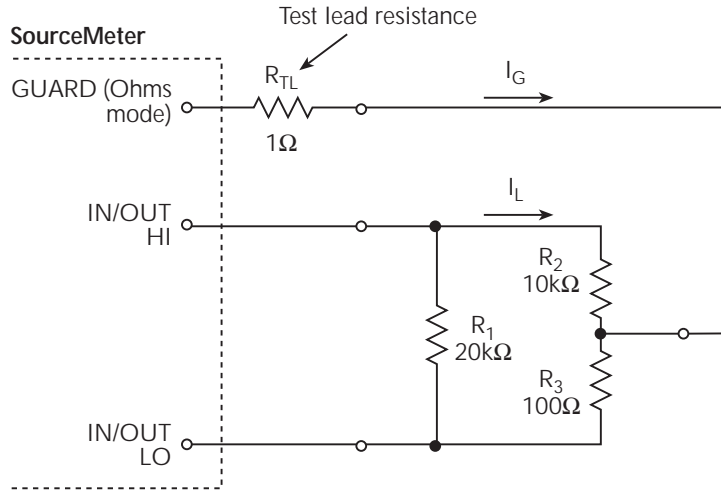

A. Local Guard Sense

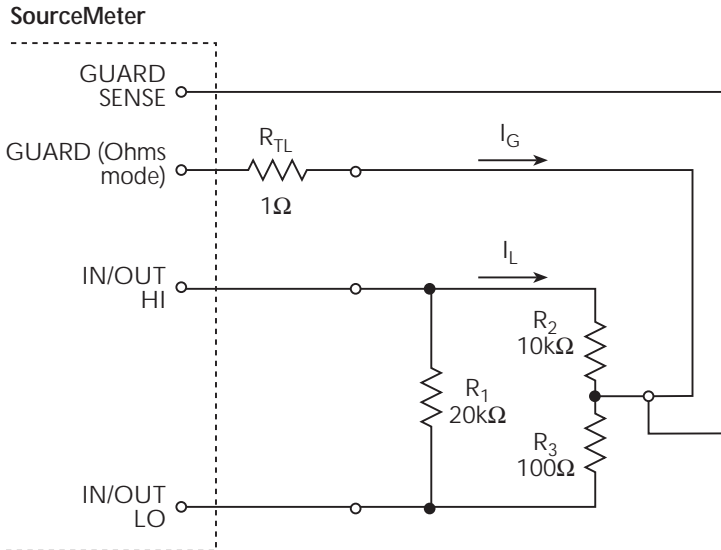

B. Remote Guard Sense

Data flow

Data flow for front panel operation is summarized by the block diagrams provided in [Figure 6-20](#). Note that if REL is enabled, the result of the rel operation is sent to the other blocks.

NOTE See [Appendix C](#) for remote operation data flow information.

With Math (FCTN) and Limit Tests (LIMITS) disabled (see [Figure 6-20A](#)), the SourceMeter displays the measurement readings. If the data store is used, these readings are also stored in the buffer for later recall. Statistical data for these readings is also available upon recall.

[Figure 6-20B](#) shows data flow when Math or Limit Tests is enabled. If Math is enabled, the result of the math operation is displayed. If Limit Tests is enabled, the raw reading along with the results of the tests (pass or fail) is displayed. As in the previous case, these readings can also be stored in the data store.

[Figure 6-20C](#) shows data flow when both Math and Limit Tests are enabled. The Math operation is performed first, and then limit tests are performed on that math result. The result of the math operation and the result of the limit tests (pass or fail) are displayed. As shown, these readings can also be stored in the data store.

Figure 6-20
Data flow front panel

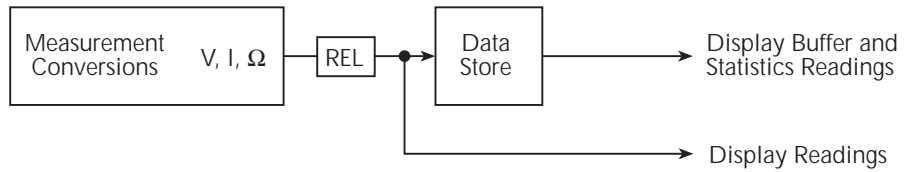

A. Math (FCTN) and Limit Tests Disabled

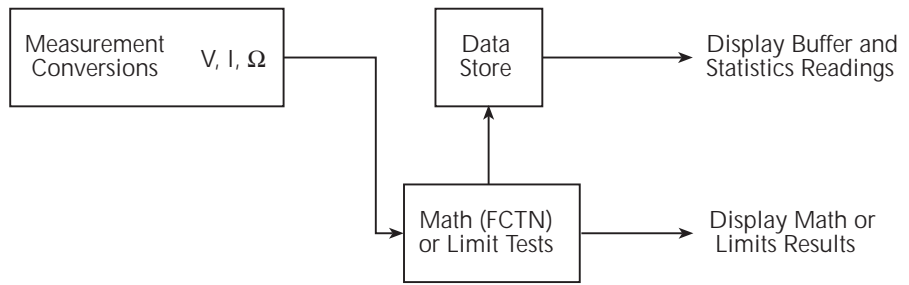

B. Math (FCTN) or Limit Tests Enabled

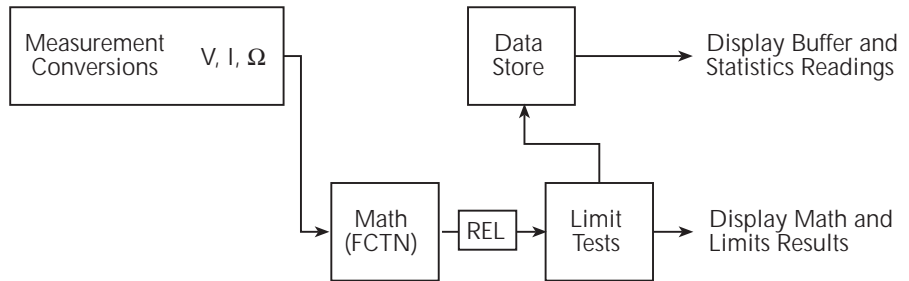

C. Both Math (FCTN) and Limit Tests Enabled

Buffer considerations

When the SourceMeter is in the process of storing readings, configuration changes affect what gets stored in the buffer. These storage considerations and restrictions are summarized in [Table 6-3](#).

Table 6-3

Buffer considerations

Configuration at start of the storage process	What happens if the basic measurement function (V, I, or Ω) is changed?	What happens if the MATH function is changed?	What happens if REL or LIMITS is changed?
Measure V, I, or Ω	Buffer tracks	V, I, or Ω stored	V, I, or Ω stored
MATH (FCTN) enabled	Buffer pauses	MATH not stored OK	REL or Limits not stored MATH stored
REL/LIMITS enabled	Buffer pauses	Buffer pauses	REL or Limits not stored OK

The first column of [Table 6-3](#) shows the SourceMeter configuration when the storage process is started. The next three columns show what happens when configuration changes are made while the SourceMeter is storing readings.

Changing V, I, or Ω measurement function

- If you started with only a basic measurement function selected, the buffer will track a basic measurement function change. For example, if you started in volts and changed to current, the buffer will store the current readings.
- If you started with MATH, REL, and/or LIMITS enabled, the buffer will stop storing readings if you change the basic measurement function. Storage will continue if you return to the original configuration.

See [Section 3](#), “[Basic source-measure procedure](#),” for more information on selecting the measurement function.

Changing MATH function

- If you started with only a basic measurement function selected, you can enable a MATH function, but only the voltage, current, or resistance component of the calculation will be stored in the buffer. The results of the MATH function will not be stored.
- If you started with a MATH function enabled, you can select a different MATH function. The results of the new MATH function are stored in the buffer.
- If you started with REL and/or LIMITS enabled, the buffer will stop storing readings if you select a MATH function. Storage will continue if you return to the original configuration.

See [Section 8](#) for more information on MATH.

Changing REL or LIMITS

- If you started with only a basic measurement function selected, you can enable REL and/or LIMITS, but only the voltage, current, or resistance component of the operation will be stored in the buffer. The results of REL and/or LIMITS are not stored.
- If you started with a MATH function enabled, only the result of the MATH calculation will be stored in the buffer if REL and/or LIMITS is enabled.
- If you started with REL and/or LIMITS enabled, you can change REL and or LIMITS. The results of new REL and/or LIMITS are stored in the buffer.

7

Range, Digits, Speed, and Filters

- **Range and digits** — Discusses maximum readings, ranging limitations, manual and autoranging, and display resolution.
- **Speed** — Discusses speed settings, which are used to control the integration period of the A/D converter.
- **Filters** — Provides information on the two types of digital filtering that can be used to reduce reading noise.

Range and digits

Range

The selected measurement range affects the accuracy of the measurements as well as the maximum signal that can be measured. Note that with the output off, dashed lines are displayed (i.e., --- μA) to indicate that measurements are not being performed.

Maximum readings

The full scale input for each voltage, current, and auto ohms measurement range is defined by the selected range. For example, $\pm 2.11\text{V}$ is the full scale reading for the 2V range, $\pm 105.5\text{mA}$ is the full scale reading for the 100mA range, and $\pm 2.11\text{k}\Omega$ is the full scale reading for the 2k Ω range. [Table 3-1](#) in [Section 3](#) lists the full scale readings for all ranges.

For manual ohms measurements, the display reading is the result of the V/I calculation. Effectively, there are no ohms ranges. Thus, there are never any leading zeroes in the display reading. For example, a resistor that is measured at 936.236k Ω will be displayed as 936.236k Ω (5-digit resolution). The RANGE keys are used to select the voltage or current measurement range.

Input levels that exceed the maximum levels cause the “OVERFLOW” message to be displayed, while 9.91E+37 will be returned via remote.

Ranging limitations

When sourcing voltage (Source V), you cannot use the RANGE keys to change the voltage measurement (Measure V) range. Also, when sourcing current (Source I), you cannot use the RANGE keys to change the current measurement (Measure I) range. For these source-measure configurations, the measurement range is determined by the selected source range. See [Appendix A](#) for ranges.

Manual ranging

For the Source V Measure I, Source I Measure V, and Ohms configurations, the RANGE arrow keys are used to select a fixed range. Note that the highest available range is dependent on the corresponding compliance setting.

Within range compliance or if the instrument displays the “OVERFLOW” message on a particular range, select a higher range until an on-range reading is displayed. Use the lowest range possible without causing an overflow to ensure best accuracy and resolution.

Auto ranging

NOTE For the Model 2430, auto ranging cannot be performed while in the Pulse Mode. Therefore, all the following information on auto ranging is not applicable to the Model 2430 Pulse Mode.

For the Source V Measure I, Source I Measure V, and Ohms configurations, press AUTO RANGE to enable auto ranging. The AUTO annunciator turns on when auto ranging is selected. With auto ranging selected, the instrument automatically chooses the best range to measure the applied signal. Note that the highest available range is dependent on the corresponding compliance setting.

Auto range considerations

If the SourceMeter has to autorange, the SDM (source-delay-measure) cycle is repeated to take the measurement on the new range. This means that any programmed source delay will be applied each time the unit has to autorange. For example, if a 1 second source delay is programmed, the unit could take 2 or more seconds to complete a reading if it has to change ranges.

The autorange algorithm used in the SourceMeters is as follows: If the reading reaches 105% of the present range, the unit will go up 3 ranges, or to the highest range possible if it can't go up 3 ranges. The unit will take another reading, then decide whether it needs to continue going up in range or pick the right range based on the reading. If the reading is 10%, 1%, or 0.1% of the present range, it will go down by 1, 2, or 3 ranges based on the reading.

Auto range change mode

The auto range change mode determines how the instrument performs auto ranging. In the SINGLE mode, the SourceMeter will auto range only after first taking a reading. In the MULTIPLE mode, the SourceMeter will auto range up on compliance in the Delay phase of the Source-Delay-Measure (SDM) cycle, thereby minimizing the possibility that a SourceMeter will be in compliance in a multiple-SourceMeter system. The SourceMeter can downrange only once a reading has been taken.

NOTE See [Section 6, "Source-delay-measure cycle,"](#) for more SDM information.

With the auto range change mode set to MULTIPLE, you can also program the soak time, which specifies the amount of time after the first point of a sweep that the unit will sit in a loop actively auto ranging up and down to allow a multiple SourceMeter configuration to settle. This process will occur only during the first SDM cycle after the initial sweep trigger. (See [Section 11, "Trigger models."](#)) This feature is especially useful for situations with long DUT settling times (such as low current measurements) when several down-range change cycles from the higher ranges are required.

The soak time takes the place of the delay time only during the delay phase of the first SDM cycle after an initial sweep trigger. See [Figure 11-1](#) for an overview of the trigger model.

Selecting the auto range change mode

To configure the auto range change mode, press CONFIG then AUTO. Choose SINGLE SRC MTR or MULTIPLE as desired from the AUTO RANGE TYPE menu. If you choose MULTIPLE, you will also be prompted to enter the SOAK time, which can be programmed in the range of 0.000s to 9999.999s.

Auto range limits

Auto range limits are included to support the auto range change mode. For voltage and current, the upper limit is controlled by the compliance range and cannot be programmed. For the auto ohms mode, however, the lower limit is adjustable. The lower limit for all three functions is programmable and must be less than or equal to the upper limit. If the lower limit is equal to the upper limit, auto ranging is effectively disabled. When auto ranging is disabled, you can manually change to any range below the lower limit (V, I or Ohms) or any range above the upper limit (Ohms only).

Setting auto range limits

To set the upper or lower auto range limit press CONFIG \uparrow or CONFIG \downarrow respectively, then use the β and \odot keys to set the limit at the ULIMIT or LLIMIT prompt. Remember that you cannot set the upper limit in the V and I modes, but the unit will display the upper limit with those two functions.

Limits evaluation

Neither the high limit nor the low limit are evaluated until the unit has switched to the autorange mode. This means that if the unit is already on a range higher than the upper limit, or lower than the lower limit when the limit is set, no range change will occur.

The upper limit is only evaluated if the unit has to upgrade. In other words, if you are on a range higher than the present upper limit, and the unit autoranges down, it can still end up on a range higher than the upper limit. The converse is true for the lower limit.

The upper and lower limits have no meaning until autoranging is turned on, but the limit will not be evaluated unless the unit has to go through an autorange. If you are already on the right range when you turn on autoranging, limits will not be evaluated.

Digits

The display resolution of the measured reading depends on the DIGITS setting. This setting is global, which means the digits setting selects display resolution for all measurement functions.

The DIGITS setting has no effect on the remote reading format. The number of displayed digits does not affect accuracy or speed. Those parameters are controlled by the SPEED setting.

Setting display resolution

There are two ways to set display resolution:

- DIGITS — Press the DIGITS key until the desired number of digits is displayed.
- CONFIG DIGITS — Press CONFIG and then DIGITS to display the digits menu. Place the cursor on the desired number of digits (3.5, 4.5, 5.5, or 6.5) and press ENTER.

NOTE The concurrent measurement (available on the secondary display by using the TOGGLE key) is always 5 digits.

Changing SPEED changes DIGITS, but changing DIGITS does not change SPEED.

Remote range and digits programming

[Table 7-1](#) summarizes the commands necessary to control range and digits. See [Section 18](#) for more details on these commands.

Range and digits commands

Table 7-1

Range and digits commands

Command	Description
:SENSe:CURRent:RANGe <n>	Select manual amps range (n = range).
:SENSe:CURRent:RANGe:AUTO <state>	Enable/disable auto amps range (state = ON or OFF).
:SENSe:VOLTage:RANGe <n>	Select manual volts measure range (n = range).
:SENSe:VOLTage:RANGe:AUTO <state>	Enable/disable auto volts range (state = ON or OFF).
:SENSe:RESistance:RANGe <n>	Select manual ohms range (n = range).
:SENSe:RESistance:RANGe:AUTO <state>	Enable/disable auto ohms range (state = ON or OFF).
:DISPlay:DIGits <n>	Set display digits (n = 4, 5, 6, or 7).

Note: For the Model 2430, the :AUTO range commands are not valid while in the Pulse Mode.

Range and digits programming example

Table 7-2 shows a programming example for controlling range and digits. The SourceMeter is set up as follows:

- Source function: volts
- Source level: 10V
- Measure function: amps
- Amps range: 10 μ A
- Display digits: 5 H

Table 7-2

Range and digits programming example

Command	Description
*RST	Restore GPIB defaults.
:SOUR:FUNC VOLT	Volts source function.
:SOUR:VOLT 10	Output 10V.
:SENS:FUNC "CURR"	Amps measure function.
:SENS:CURR:RANG 10E-6	10 μ A range.
:DISP:DIG 5	5 H display digits.
:OUTP ON	Turn on output.
:READ?	Trigger and acquire reading.
:OUTP OFF	Turn off output.

Speed

The Speed/Accuracy menu is used to set the integration time of the A/D converter (period of time the input signal is measured). The integration time affects the usable digits, the amount of reading noise, and the ultimate reading rate of the instrument. The integration time is specified in parameters based on the number of power line cycles (NPLC), where 1 PLC for 60Hz is 16.67msec (1/60) and 1 PLC for 50Hz and 400Hz is 20msec (1/50).

In general, the fastest integration time (FAST; 0.01 PLC) results in increased reading noise and fewer usable digits. The slowest integration time (HI ACCURACY; 10 PLC) provides the best noise rejection. In-between settings are a compromise between speed and noise. The default power-on speed setting is NORMAL (1 PLC).

NOTE For the Pulse Mode of the Model 2430, the valid NPLC range is 0.01 to 0.1 PLC.

The speed setting affects both the NMRR (normal mode rejection ratio) and CMRR (common mode rejection ratio). Normal mode noise is the noise signal between the HI and LO input terminals, while common mode noise is the noise signal between LO and chassis ground. See [Appendix A](#) for NMRR and CMRR specifications.

Setting speed

Speed is set from the Speed Accuracy menu and is structured as follows. Use [Section 1](#), “[Rules to navigate menus](#),” to check and/or change the speed setting.

NOTE For the Pulse Mode of the Model 2430, speed is set from Pulse Speed menu. This menu structure is located after the Speed Accuracy menu. Use the “[Rules to navigate menus](#)” in [Section 1](#) to check and/or change the speed setting.

Front panel speed control

Press SPEED or CONFIG SPEED to display the menu.

- FAST — Sets speed to 0.01 PLC and sets display resolution to 3Hdigits.
- MED — Sets speed to 0.10 PLC and sets display resolution to 4Hdigits.
- NORMAL — Sets speed to 1.00 PLC and sets display resolution to 5Hdigits.
- HI ACCURACY — Sets speed to 10.00 PLC and sets display resolution to 6Hdigits.
- OTHER — Use to set speed to any PLC value from 0.01 to 10. Display resolution is not changed when speed is set with this option.

NOTE After setting speed, display resolution can be changed using the DIGITS key.

PULSE SPEED (NPLC) – Model 2430 Pulse Mode

Press SPEED or CONFIG SPEED to display the speed choices:

0.01 0.02 0.03 0.04 0.05 0.06 0.07 0.08 0.09 0.10

NOTE Display resolution for the Model 2430 Pulse Mode is not affected by the speed setting.

Remote speed programming

Speed commands

Table 7-3 summarizes commands to control speed. See Section 18, “Set measurement speed,” for more information.

NOTE The speed setting is global, which means that setting the speed for one function affects the speed for the other functions. However, the speed setting is stored in source memory, and you can use this feature to change speed during a sweep. See Section 10 for details on using source memory.

Table 7-3
Speed commands

Command	Description
:SENSe:CURRent:NPLCycles <n>	Set amps speed (n = PLC, 0.01 to 10)*.
:SENSe:VOLTage:NPLCycles <n>	Set volts speed (n = PLC, 0.01 to 10)*.
:SENSe:RESistance:NPLCycles <n>	Set ohms speed (n = PLC, 0.01 to 10)*.

* For the Model 2430 Pulse Mode, n = PLC, 0.01 to 0.10.

Filters

NOTE For the Pulse Mode of the Model 2430, filtering is not used, and therefore, cannot be enabled. Pressing the FILTER key results in the "Invalid in Pulse Mode" message.

Filter lets you set the filter response to stabilize noisy measurements. The SourceMeter uses a digital filter, which is based on reading conversions. The displayed, stored, or transmitted reading is an average of a number of reading conversions (from 1 to 100).

There are two averaging filter types to choose from: repeating and moving (Figure 7-1). For the repeating filter (which is the power-on default), the stack (filter count) is filled, and the conversions are averaged to yield a reading. The stack is then cleared, and the process starts over. Choose this filter for sweeping so readings for other source levels are not averaged with the present source level.

The moving average filter uses a first-in, first-out stack. When the stack (filter count) becomes full, the measurement conversions are averaged, yielding a reading. For each subsequent conversion placed into the stack, the oldest conversion is discarded. The stack is re-averaged, yielding a new reading.

When the filter is first enabled, the stack is empty. Keep in mind that a filtered reading is not yielded until the stack is full. The first reading conversion is placed in the stack and is then copied to the other stack locations in order to fill it. Thus, the first filtered reading is the same as the first reading conversion. Now the normal moving average filter process can continue. Note that a true average is not yielded until the stack is filled with new reading conversions (no copies in stack). For example, in Figure 7-1A, it takes ten filtered readings to fill the stack with new reading conversions. The first nine filtered readings are calculated using copied reading conversions.

NOTE Sweeping with moving average filter enabled is not recommended as it may yield incorrect results. The desired readings may be changing with the sweep source values and these changes can be skewed by the averaging technique.

Response time considerations

The filter averaging mode and count affect the overall reading speed. The moving averaging filter is much faster than the repeat averaging filter because the unit does not have to refill the filter stack for each reading. Also, the number of readings averaged will affect reading speed; as the number of readings averaged increases, the reading speed decreases.

Front panel filter control

Configuring filter

Filter type and count is configured from the CONFIGURE FILTERING menu and is structured as shown in [Figure 7-2](#). Use [Section 1](#), “Rules to navigate menus,” to check and/or change the filter configuration.

CONFIGURE FILTERING menu

Press CONFIG and then FILTER to display the menu.

- AVERAGING MODE — Use this menu item to select filter type (MOVING or REPEAT).
- AVERAGE COUNT — Use this menu item to specify filter count (1 to 100 readings).

NOTE The configured filter is the same for all measurement functions.

Enabling filter

The filter is enabled by pressing the FILTER key. The “Filter Enabled” message and the filter count are briefly displayed. The FILT annunciator is on while the filter is enabled. Pressing FILTER a second time disables filter.

Figure 7-1
Moving average and repeating filters

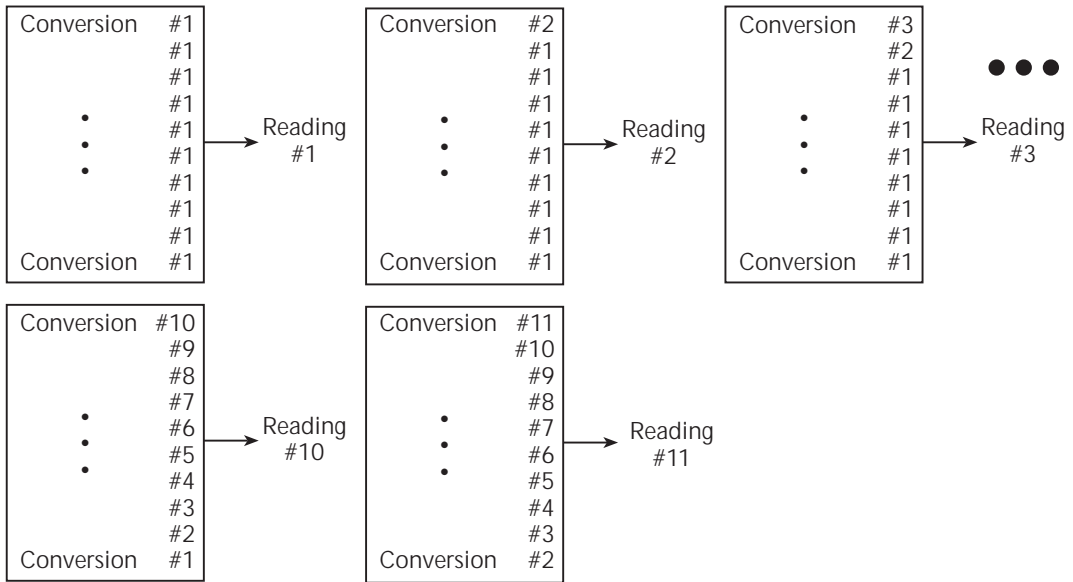

A. Type - Moving Average, Readings = 10

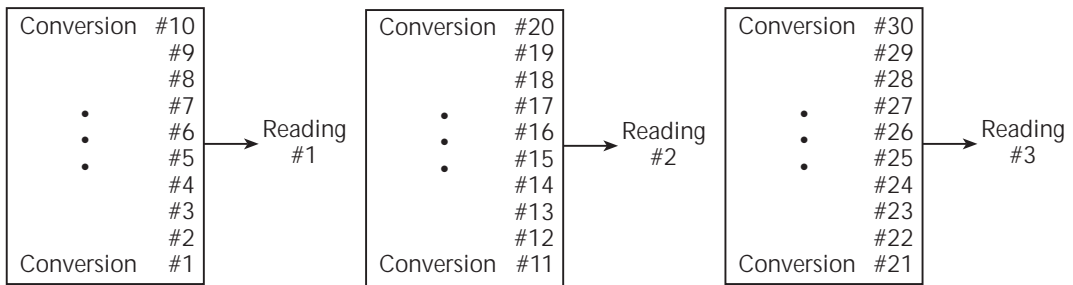

B. Type - Repeating, Readings = 10

Response time

The filter parameters have speed and accuracy trade-offs for the time needed to display, store, or output a filtered reading. These affect the number of reading conversions for speed versus accuracy and response to input signal changes.

Figure 7-2
Filter configuration menu tree

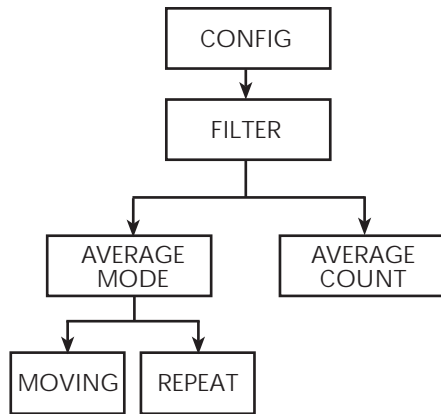

Remote filter programming

Filter commands

Table 7-4 summarizes filter commands. See Section 18, “SENSe1 subsystem,” “Configure and control filter,” for more details.

Table 7-4
Filter commands

Command	Description
:SENSe:AVERAge:TCONtrol <type>	Select filter type (type = REPeat or MOVing).
:SENSe:AVERAge:COUNt <n>	Set filter count (n = count, 1 to 100).
:SENSe:AVERAge <state>	Enable/disable filter (state = ON or OFF)*.

* For the Model 2430 Pulse Mode, the filter cannot be enabled.

8

Relative and Math

- **Relative** — Discusses the relative (REL) mode that can be used to null offsets or subtract a baseline value from readings.
- **Math operations** — Provides detailed information on the following math (FCTN) operations: power, offset-compensated ohms, varistor, alpha, voltage coefficient, and percent deviation.

Relative

The rel (relative) feature can be used to null offsets or subtract a baseline reading from present and future readings. With REL enabled, subsequent readings will be the difference between the actual input value and the rel value as follows:

Displayed Reading = Actual Input - Rel Value

Once a rel value is established for a measurement function, the value is the same for all ranges. For example, if 5V is set as a rel value on the 20V range, the rel value is also 5V on the 2V and 200mV ranges.

Selecting a range that cannot accommodate the rel value does not cause an overflow condition, but it also does not increase the maximum allowable input for that range. For example, on 20V range, the SourceMeter still overflows for a >21.1V input.

NOTE When rel is enabled, the REL annunciator turns on. Changing measurement functions disables rel.

Front panel rel

Enabling and disabling rel

Rel can be used to null out zero offsets or to establish a zero baseline by pressing the REL key. The reading (which becomes the rel value) is subtracted from itself. As a result, a zero reading is displayed. Pressing REL a second time disables rel.

Defining a rel value

A unique rel value can be established for the selected measurement function from the front panel as follows:

1. Press CONFIG and then REL. The present rel value will be displayed.
2. Set the desired rel value. (See [Section 1](#), “[Rules to navigate menus](#),” for details.)
3. With the desired rel value displayed, press ENTER. The SourceMeter will return to the normal source-measure display with rel enabled. The reading will reflect the defined rel value.

Remote rel programming

Rel commands

[Table 8-1](#) summarizes rel commands. See [Section 18](#), “CALCulate2” subsystem, for additional information.

Table 8-1

Rel commands

Command	Description
:CALCulate2:NULL:OFFSet <n>	Define null (rel) value (n = rel value).
:CALCulate2:NULL:STATe <state>	Enable/disable rel (state = ON or OFF).
:CALCulate2:NULL:ACQuire	Automatically acquire rel value (must have non-overflowed reading).

Rel programming example

[Table 8-2](#) lists commands for setting up and enabling rel. These commands set up the SourceMeter as follows:

- Rel value: 5
- Rel state: enabled

Table 8-2

Rel programming example

Command	Description
:CALC2:NULL:OFFS 5	Rel value =5.
:CALC2:NULL:STAT ON	Enable rel.

Math operations

Built-in math functions

The SourceMeter has built-in math functions to calculate the following:

- Power
- Offset Compensated Ω
- Varistor Alpha
- Voltage Coefficient
- Percent Deviation

The Power and Percent Deviation math functions use a single voltage and/or current measurement to perform the calculation. The Offset-Compensated Ω , Varistor Alpha, and Voltage Coefficient math functions require 2-point measurements to perform a calculation.

Power

This math function calculates power using the measured voltage and measured current values as follows:

$$\text{Power} = V \times I$$

where:

V = measured voltage

I = measured current

Note that power is displayed in watts with “W” in the units field of the display.

Offset-compensated ohms

The presence of thermal EMFs (V_{EMF}) can adversely affect low-resistance measurement accuracy. To overcome these unwanted OFFset voltages, use the Offset-Compensated Ω measurement method. In general, this method measures resistance (V/I) at a specific I-Source level and then subtracts a resistance measurement made with the I-Source set to a different level (typically zero).

NOTE *Offset-compensated Ω is also available from the CONFIG OHMS menu structure. Using Offset-Compensated Ω from this menu automatically selects zero as one of the source values. For details, see [Section 4](#), “Offset-compensated ohms.”*

This two-point measurement method is mathematically expressed as:

Offset-Compensated $\Omega = \Delta V / \Delta I$ where $\Delta V = V2 - V1$ and $\Delta I = I2 - I1$.

- V1 is the voltage measurement with the I-Source set to a specific level.
- V2 is the voltage measurement with the I-Source set to a different level (typically zero).
- I1 is the current measurement with the I-Source set to a specific level.
- I2 is the current measurement with the I-Source set to a different level (typically zero).

You will be prompted to enter the two I-Source values, and the results is displayed in ohms with the “ Ω ” symbol in the units field of the display.

Varistor alpha

This math formula is used to determine varistor alpha (α), an important parameter that defines varistor characteristics. Alpha is defined as the logarithmic ratio of two voltage measurement points on a non-linear V-I curve and is expressed as follows:

$$\alpha = \frac{\log(I2/ I1)}{\log(V2/ V1)}$$

where:V1 is the voltage measurement at the first I-Source point.

V2 is the voltage measurement at the second I-Source point.

The log (x) function uses the absolute value of x.

When configuring this math function, you will be prompted to enter the two I-source values. (See “[Front panel math operations](#)” later in this section.)

Voltage coefficient

High value or high-megohm resistors exhibit a change in resistance with a change in applied voltage. This effect is known as voltage coefficient. The voltage coefficient is the percent change in resistance per unit change in applied voltage and is defined as follows:

$$\text{Coefficient}\% = \frac{\Delta R}{R2 \times \Delta V} \times 100\%$$

where: $\Delta R = R2 - R1$

$\Delta V = V2 - V1$

R1 is the resistance measurement at the first source point.

R2 is the resistance measurement at the second source point.

V1 is the voltage measurement at the first source point.

V2 is the voltage measurement at the second source point.

If sourcing voltage, you will be prompted to enter the two V-source values. If sourcing current, you will be prompted to enter the two I-source values. (See “Front panel math operations,” page 8-6.)

Percent deviation

This calculation provides the percent deviation between the normal display reading and the user set reference value:

$$\%Deviation = \frac{(X - Y)}{Y} \times 100$$

where: X is the normal display measurement reading (V, I, or Ω).

Y is the reference value.

When prompted to enter the reference value (Y), you can enter the value or have the SourceMeter acquire the reference value. To acquire the reference value, turn on the output and press AUTO. The SourceMeter will perform a measurement and display that reading as the reference.

Front panel math operations

Perform the steps below to select and enable a math expression.

1. Select the appropriate source (V or I) for the math expression.
2. Press CONFIG and then FCTN to display the math expression selections. Place the cursor on the desired math expression and press ENTER:
 - For 2-point math expressions, you will be prompted to enter the two source values. Press ENTER after entering each source value.
 - For Percent Deviation, you will be prompted to set the reference value. The following methods are available:
 - User-specified reference value — Enter the desired reference value and press ENTER.
 - Acquire reference value — With the output on, press the AUTO range key. The SourceMeter will perform a measurement and display that reading as the reference. Press ENTER to select that reference value.
3. Turn on the output by pressing the ON/OFF key.
4. Press the FCTN key to enable the selected math function. The MATH annunciator will turn on, and the result of the math expression will be displayed.

Note that with FCTN enabled, the sweep for a 2-point math expression runs continuously. Each sweep updates the reading. The source value cannot be changed while the 2-point sweep is running. However, the range keys remain active.

Remote math operations

Math commands

[Table 8-3](#) summarizes commands to control the built-in math functions. See [Section 18, “Calculate subsystems,”](#) for more detailed information on these and other math commands.

Table 8-3
Math commands

Command	Description
:CALCulate:MATH:NAME <name>	Select match expression (name = “POWER,” “OFFCOMPOHM,” “VOLTCOEF,” “VARALPHA”)
:CALCulate:STATE <state>	Enable/disable math (state = ON or OFF).
:CALCulate:DATA?	Query math data.

User-defined math functions

In addition to the pre-defined math functions, you can also define your own functions by using appropriate remote commands (user-defined math functions are not available from the front panel). The following paragraphs summarize the basic commands for user-defined functions and also list a basic programming example. See [Section 18, “Calculate subsystems,”](#) for more details on user-defined math functions.

Commands for user-defined math functions

[Table 8-4](#) summarizes the commands for user-defined math functions. To define a math function:

1. If desired, assign units to the calculation result using :CALC:MATH:UNIT. Units is stored for the calculation.
2. Assign a name to the expression (using up to 10 ASCII characters) using the :CALC:MATH:NAME “user-name” command.
3. Define the expression using the :CALC:MATH:DEFine or :CALC:MATH:EXPReSSion command. The new expression is the one that will be presently selected.
4. Enable the math function by sending :CALC:STATE ON.
5. Turn on the output by sending :OUTP ON, then send :INIT to trigger the unit.
6. Request the data with the :CALC:DATA? query.

Table 8-4

Commands for user-defined math functions

Command	Description
:CALCulate:MATH:UNITs <name>	Specified units for user-defined function (name = three ASCII characters in quotes).
:CALCulate:MATH:NAME <name>	Define math name (name = "user-name").
:CALCulate:MATH[EXPrESSion] <form>	Define math formula (form = formula). Valid names: VOLTage, CURRent, RESistance, TIME. Valid math operators: + - * / ^ log, ln, sin, cos, tan, exp.
:CALCulate:STATe <state>	Enable/disable math (state = ON or OFF).
:CALCulate:DATA?	Query math data.

User-defined math function programming example

Table 8-5 shows the command sequence for a typical user-defined math function. This example defines a percent deviation math function.

Table 8-5

User-defined math function programming example

Command	Description
*RST	Restore GPIB defaults.
:SENS:FUNC:OFF:ALL	Disable concurrent functions.
:SENS:FUNC:ON "RES"	Select resistance function.
:CALC:MATH:UNIT "%"	Define "%" units name.
:CALC:MATH:EXPR:NAME "PER_DEV"	Define math expression name.
:CALC:MATH:EXPR (((RES - 10e3) / 10e3) * 100)	Define math expression.
:CALC:STAT ON	Enable math data.
:OUTP ON	Turn on output.
:INIT	Trigger unit.
:CALC:DATA?	Request math data.

9 Data Store

- **Data store overview** — Outlines basic data store (buffer) capabilities.
- **Storing readings** — Discusses the procedure for storing readings in the internal buffer.
- **Recalling readings** — Provides detailed information for recalling readings stored in the buffer.
- **Buffer statistics** — Discusses the various statistics available on buffer data including minimum and maximum values, average (mean), standard deviation, and peak-to-peak values.
- **Timestamp format** — Explains how to select the timestamp format (absolute or delta) for recalled buffer readings.
- **Remote programming** — Summarizes the commands to control the data store and provides a programming example.

Data store overview

The SourceMeter has a data store (buffer) to store from 1 to 2500 source-measure readings. The instrument stores the source-measure readings that are displayed during the storage process. Each source-measure reading also includes the buffer location number and a timestamp. Cmpl will flash in buffer recall if reading is in compliance.

The data store also provides statistical data on the measured readings stored in the buffer. These include minimum, maximum, mean, and standard deviation.

NOTE When a sweep is performed, the readings are automatically stored in the buffer.

Front panel data store

Storing readings

Perform the following steps to store readings:

1. Set up the SourceMeter for the desired configuration.
2. Press the STORE key.
3. Use the left and right cursor keys, and the SOURCE or RANGE arrow keys to specify the number of readings to store in the buffer.
4. Press ENTER. The asterisk (*) annunciator turns on to indicate data storage operation. It will turn off when the storage is finished.
5. Turn on the output and (if necessary) trigger the unit to begin taking and storing readings.

Recalling readings

Readings stored in the buffer are displayed by pressing the RECALL key. The source-measure readings are positioned at the left side of the display, while the buffer location number and timestamp are positioned at the right side.

Buffer location number

The buffer location number indicates the memory location of the source-measure reading. Location #0000 indicates that the displayed source-measure reading is stored at the first memory location. If limit testing was performed, a "P" or an "F" will precede the buffer location number to indicate the pass/fail result of the test. Limit testing is covered in [Section 12](#).

Timestamp

The first source-measure reading stored in the buffer (#0000) is timestamped at 0000000.000 seconds. Subsequent readings can be recalled in absolute or delta timestamp format. For the absolute format, the timestamp references readings to zero seconds. For the delta format, the timestamp indicates the time between the displayed reading and the reading before it. To set the timestamp format, see “[Timestamp format](#)” in this section.

Displaying other buffer readings

To display the other source-readings stored in the buffer, display the desired memory location number. The arrow keys for SOURCE and RANGE increment and decrement the selected digit of the location number. Cursor position is controlled by the EDIT arrow keys. When scrolling forward past the last stored reading, the buffer wraps to the first stored reading. Conversely, when scrolling in reverse past the first stored reading, the buffer wraps to the last stored reading. A different key click tone announces the wrap-around.

The memory location number can also be keyed in using the 0 through 9 number keys. Position the cursor on the appropriate digit and press the desired number key. The cursor then moves right to the next least significant digit. For example, to display reading #0236, position the cursor all the way to the left (MSD) and press 0, 2, 3, 6. Note that if keying in a number that exceeds the buffer size, the reading at the highest memory location is displayed.

To exit from the data store recall mode, press EXIT.

Buffer statistics

With the data store in the recall mode, buffer statistics are displayed by using the TOGGLE key. Use the TOGGLE key to sequence through the statistics and return the SourceMeter to the normal data store recall state. Pressing EXIT at any time returns the instrument to the normal source-measure display state.

NOTE Buffer statistics for V, I, Ω and MATH are calculated and displayed separately. For example, if ohms readings are displayed, all buffer statistics displayed are based on ohms readings.

Minimum and maximum

This mode displays the minimum and maximum readings stored in the buffer. The buffer location number and timestamp are also provided for these readings. If desired, you can go to those buffer locations to obtain more data about the readings.

Peak-to-peak

This mode displays the peak-to-peak reading (peak-to-peak = Maximum - Minimum).

Average

The average mode displays the mean (average) of all measured readings stored in the buffer. The following equation is used to calculate mean:

$$y = \frac{\sum_{i=1}^n X_i}{n}$$

where: y is the average.
 X_i is a stored reading.
 n is the number of stored readings.

Standard deviation

This mode displays the standard deviation of buffered readings. The following equation is used to calculate standard deviation:

$$y = \sqrt{\frac{\sum_{i=1}^n X_i^2 - \frac{1}{n} \left(\sum_{i=1}^n X_i \right)^2}{n-1}}$$

where: y is the standard deviation.
 X_i is a stored reading.
 n is the number of stored readings.

Timestamp format

Buffer readings can be recalled using the absolute timestamp format or the delta format. For the absolute format, readings are referenced to zero seconds. For the delta format, the timestamp indicates the time between the displayed reading and the previous reading.

Perform the following steps to set the timestamp format:

1. While in the normal display mode, press CONFIG and then STORE to display the timestamp choices.
2. Place the cursor on ABSOLUTE or DELTA and press ENTER.

Buffer considerations

From the front panel, 2500 source-measure readings can be stored and accessed using the method described earlier in this section. Over the bus, however, there are actually two separate 2500 reading buffers for a total of 5000 readings. The :TRACe buffer is a 2500 reading buffer used by front panel data store, bus :TRACe commands, and to store sweep data, and it is battery backed-up. The READ? buffer is a separate 2500 reading buffer that can only be accessed over the bus using the :READ? command.

Remote command data store

Data store commands

Table 9-1 summarizes commands associated with data store operation. See Section 18, “TRACe subsystem” and “CALCulate3,” for more detailed information on these commands.

Table 9-1

Data store commands

Command	Description
:TRACe:DATA?	Read contents of buffer.
:TRACe:CLEAr	Clear buffer.
:TRACe:FREE?	Read buffer memory status.
:TRACe:POINts <n>	Specify buffer size (n = buffer size).
:TRACe:POINts:ACTual?	Query number of stored readings.
:TRACe:FEED <name>	Specify reading source. Name = SENSE[1] (raw readings), CALCulate[1] (Calc1 readings), or CALCulate2 (Calc2 readings).
:TRACe:FEED:CONTrol <name>	Start or stop buffer. Name = NEXT (fill buffer and stop) or NEVER (disable buffer).
:TRACe:TSTamp:FORMat <name>	Select timestamp format. Name = ABSolute (reference to first buffer reading) or DELTa (time between buffer readings).
:CALCulate3:FORMat <name>	Select buffer statistic (name = MEAN, SDEVIation, MAXimum, MINimum, or PKPK).
:CALCulate3:DATA?	Read buffer statistic data.*

* If :TRACe:FEED is set to :SENSe[1], this command will return one V, I, Ω and MATH result.

Data store programming example

Table 9-2 summarizes the commands for basic data store operation. These commands set up the SourceMeter as follows:

- Reading source: raw readings.
- Number of points: 10.
- Acquired data: buffer readings, mean (average), and standard deviation.

NOTE You can determine when the buffer is full by reading the appropriate status register bit. See [Section 15](#) for details on the status structure.

Table 9-2

Data store example

Command	Description
*RST	Restore GPIB defaults.
:SOUR:VOLT 10	Source 10V.
:TRAC:FEED SENS	Store raw readings in buffer.
:TRAC:POIN 10	Store 10 readings in buffer.
:TRAC:FEED:CONT NEXT	Enable buffer.
:TRIG:COUN 10	Trigger count = 10.
:OUTP ON	Turn on output.
:INIT	Trigger readings.
:TRACE:DATA?	Request raw buffer readings.
:CALC3:FORM MEAN	Select mean buffer statistic.
:CALC3:DATA?	Request buffer mean data.
:CALC3:FORM SDEV	Select standard deviation statistic.
:CALC3:DATA?	Request standard deviation data.

10

Sweep Operation

- **Sweep types** — Describes the four basic sweep types: Linear staircase, logarithmic staircase, custom, and source memory sweep.
- **Configuring and running a sweep** — Discusses the procedure for setting up and performing sweeps including selecting and configuring a sweep, setting the delay, and performing a sweep.
- **Pulse Mode sweeps (Model 2430 only)** — Covers sweep operation for the Pulse Mode of the Model 2430.

Sweep types

Sweeps allow you to program the instrument to step through specific voltage and current values and perform measurements at each source value. The four basic sweep types, which are described in the following paragraphs, include:

- Linear staircase
- Logarithmic staircase
- Custom
- Source memory

NOTE Only voltage or current sweeps can be performed. Sweep readings are automatically stored in the buffer. See [Section 9](#) for details on the data store (buffer).

Linear staircase sweep

As shown in [Figure 10-1](#), this sweep steps from a start source value to an ending (stop) source value. Programmable parameters include the start, stop, and step source levels.

When this sweep is triggered to start, the output will go from the bias level to the start source level. The output will then change in equal steps until the stop source level is reached. With trigger delay set to zero, the time duration at each step is determined by the source delay and the time it takes to perform the measurement (NPLC setting). Note that the delay cannot change once a sweep is configured and running and is the same for all steps.

Figure 10-1
Linear staircase sweep

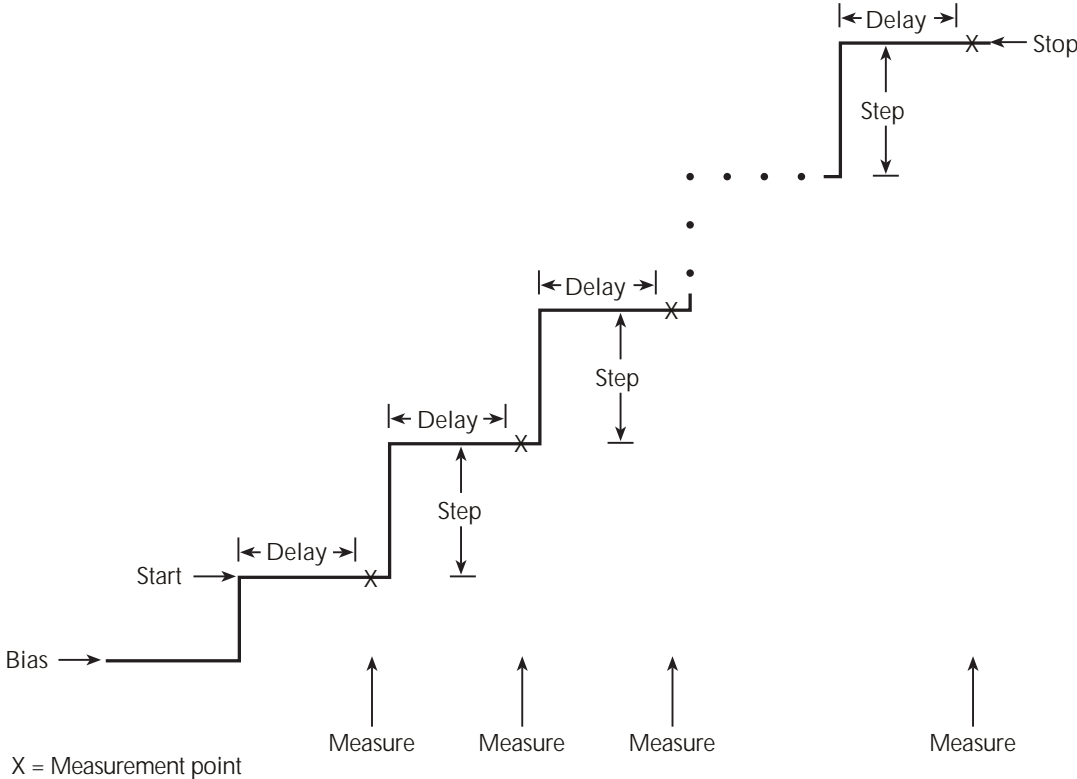

Logarithmic staircase sweep

This sweep is similar to the linear staircase sweep. The steps, however, are done on a logarithmic scale as shown in the example sweep in [Figure 10-2](#). This is a 5-point log sweep from 1 to 10V. As with the staircase sweep, the delay period is the same for all steps.

Figure 10-2

Logarithmic staircase sweep (example 5-point sweep from 1 to 10 volts)

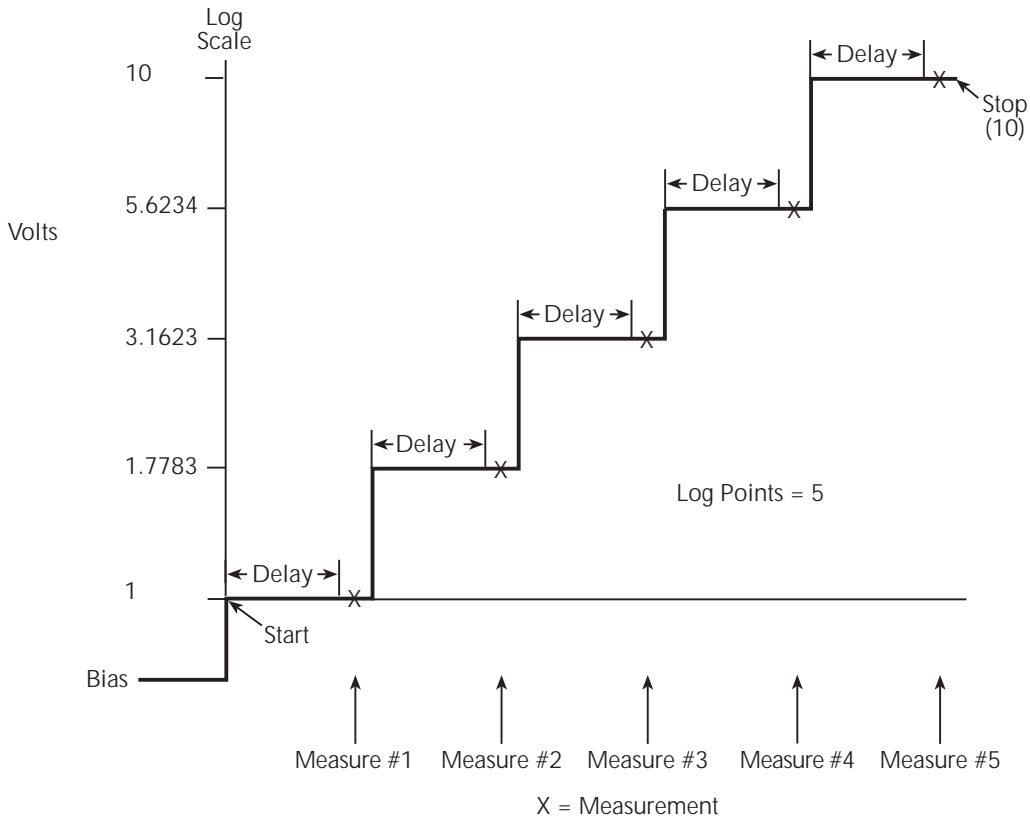

The programmable parameters for a log sweep include the start and stop levels and the number of measurement points for the sweep. The specified start, stop, and point parameters determine the logarithmic step size for the sweep. Step size for the sweep in [Figure 10-2](#) is calculated as follows:

$$\begin{aligned}\text{Log Step Size} &= \frac{\log_{10}(\text{stop}) - \log_{10}(\text{start})}{\text{Points} - 1} \\ &= \frac{\log_{10}(10) - \log_{10}(1)}{5 - 1} \\ &= \frac{(1 - 0)}{4} \\ &= 0.25\end{aligned}$$

Thus, the five log steps for this sweep are 0, 0.25, 0.50, 0.75, and 1.00. The actual V-Source levels at these points are listed in [Table 10-1](#) (the V-Source level is the anti-log of the log step).

Table 10-1
Logarithmic sweep points

Measure point	Log step	V-Source level (volts)
Point 1	0	1
Point 2	0.25	1.7783
Point 3	0.50	3.1623
Point 4	0.75	5.6234
Point 5	1.0	10

When this sweep is triggered to start, the output will go from the bias level to the start source level (1V) and sweep through the symmetrical log points. With trigger delay set to zero, the time duration at each step is determined by the source delay and the time it takes to perform the measurement (NPLC setting).

Abort on compliance

This feature aborts a sweep in progress if compliance is detected. There are three modes, never, early, and late. Never turns off the feature, early will abort as soon as compliance is detected at the beginning of the SDM cycle, and late aborts at the end of the SDM cycle. See [“Configuring and running a sweep” on page 10-12](#).

Custom sweep

This sweep type lets you configure a customized sweep. Programmable parameters include the number of measurement points in the sweep and the source level at each point.

When this sweep is started, the output goes from the bias level to the first source-measure point in the sweep. The sweep will continue through the source-measure points in the order they were programmed and stop after the last source-measure point. With trigger delay set to zero, the time duration at each step is determined by the source delay and the time it takes to perform the measurement (NPLC setting). This delay is the same for all sweep points.

Source memory sweep

For a source memory sweep, up to 100 setup configurations can be saved in memory. When the sweep is performed, the setup at each memory point is recalled. This allows multiple functions and math expressions to be used in a sweep. For example, the first point in a source memory sweep may source voltage and measure current, the next point may source current and measure voltage, the third point may source voltage and measure voltage, and the last point may use a math expression. This feature allows you to customize each sweep point with specific instrument settings instead of being tied to one set of settings for all sweep points.

Once source memory setups are saved and the sweep is initiated, the SourceMeter then sequences through the setups very rapidly. This feature allows you to use the instrument as a fast, automatic test sequencer.

NOTE *NPLC caching can be used to speed up source memory sweeps. See [Section 3, "NPLC caching,"](#) for details.*

Current range holdoff

Current range holdoff adds the ability to speed up low-current measurements when sourcing voltage and measuring current. This feature is only available when doing source memory sweeps. It will momentarily set the measure range to the compliance range to overcome the effects of capacitance by quickly charging the capacitance on the higher range, but return to the lower measurement range to obtain a good low-current measurement. This avoids being limited by range compliance, which would require either a longer delay time, or having to take the measurement on a higher current range. This feature is available only by remote, but both parameters are saved for each memory location.

Sweep configuration

The user specifies the number of memory location points to sweep and where to start the sweep. For example, you can specify a six point sweep that starts at memory location 98. When the sweep is started, the setups at memory location points 98, 99, 100, 1, 2, and 3 are recalled. When sweeping past point 100, the sweep automatically wraps back to memory location point 1. The default and typical scenario is starting the source memory sweep at location 1.

NOTE *These and other components of the sweep are configured from the CONFIGURE SWEEPS menu. See “[Configuring and running a sweep](#)” later in this section.*

Setups are saved in battery backed-up memory, and they remain and can be recalled even if the SourceMeter loses external power.

Saving and restoring source memory setups

Source memory setups are saved in memory and restored from the SAVESETUP (SOURCE MEMORY) option of the MAIN MENU. (See [Section 1](#), “[Main menu.](#)”)

NOTE *Source memory setups are different from the power-on and user-defined setups, which are programmed from the SAVESETUP (GLOBAL) MAIN MENU option. See [Section 1](#) for details.*

Saving source memory setups

Perform the following steps to save source memory setups:

1. Configure the SourceMeter for the desired source, measure, and/or math expression operation.
2. Press MENU to display the MAIN MENU:
 - Select SAVESETUP.
 - Select SOURCE MEMORY.
 - Select SAVE.
 - Use the SOURCE arrow keys, and the cursor keys to display the desired memory location, and press ENTER.
 - Use the EXIT key to back out of the menu structure.
3. Configure the SourceMeter for the next point in the sweep, and repeat Step 2 to save that setup in the next memory location.
4. Repeat Step 3 for all points in the sweep.

Restoring source memory setups

In addition to automatically sweeping through source memory locations (see [“Configuring and running a sweep”](#) later in this section), you can also recall them individually as follows:

1. Press MENU to display the MAIN MENU.
2. Select SAVESETUP, then press ENTER.
3. Choose SOURCE MEMORY, then press ENTER.
4. Select RESTORE, then press ENTER.
5. Select the source memory location to restore (1-100), then press ENTER.

Saving multiple source memory sweeps

If desired, you can save multiple source memory sweeps in the 100 memory locations. For example, you could save setups in locations 1 through 4 for one sweep, and other setups in any other range of memory locations such as locations 50 through 58. To select which sweep to execute, simply select two settings: (1) the sweep start location, and (2) the number of sweep points. (See [“Performing a source memory sweep”](#) later in this section.)

Saved source memory configurations

[Table 10-2](#) summarizes the configurations that are saved at each source memory location along with the equivalent remote command. See [Section 18](#) for more details on these remote commands. The SCPI command reference tables, [Table 18-1](#) through [Table 18-11](#), also list source memory parameters.

Table 10-2
Source memory saved configurations

Mode	Remote command
Current integration rate	SENSe[1]:CURRent:NPLCycles
Resistance integration rate	SENSe[1]:RESistance:NPLCycles
Voltage integration rate	SENSe[1]:VOLTage:NPLCycles
Concurrent functions	SENSe[1]:FUNctIon:CONCurrent
Enable functions	SENSe[1]:FUNctIon:ON
Disable functions	SENSe[1]:FUNctIon:OFF
Manual/auto ohms	SENSe[1]:RESistance:MODE
Offset-compensated ohms	SENSe[1]:RESistance:OCOMpensated
Enable/disable filter	SENSe[1]:AVERage:STATe
Filter type	SENSe[1]:AVERage:TCONtrol
Filter count	SENSe[1]:AVERage:COUNT
2430 pulse function	SOURce[1]:FUNctIon:SHAPE
Source mode	SOURce[1]:FUNctIon:MODE
Source delay†	SOURce[1]:DELay
Source auto delay†	SOURce[1]:DELay:AUTO
Scaling factor*	SOURce[1]...X...:TRIGgered:SFACTOR
Enable/disable scaling*	SOURce[1]...X...:TRIGgered:SFACTOR:STATe
2430 pulse width	SOURce[1]:PULSe:WIDTh
2430 pulse delay	SOURce[1]:PULSe:DELay
Source Value, Range, Auto Range	
Sense Protection, Range, Auto Range	
Enable/disable auto-zero	SYSTem:AZERo:STATe
Enable/disable remote sense	SYSTem:RSENse
Front/rear terminals	ROUte:TERMinals
Enable/disable CALC1	CALCulate1:STATe
CALC1 math expression	CALCulate1:MATH[:EXPRession]:NAME
CALC2 input path	CALCulate2:FEED
REL value	CALCulate2:NULL:OFFSet
REL on/off	CALCulate2:NULL:STATe
Limit 1 on/off	CALCulate2:LIMit[1]:STATe
Limit 1 fail conditions	CALCulate2:LIMit[1]:COMPLIance:FAIL

Table 10-2 (cont.)

Source memory saved configurations

Mode	Remote command
Limit 1 bit pattern	CALCulate2:LIMit[1]:COMPLIance:SOURce2
Enable/disable Limit X**	CALCulate2:LIMitX:STATE
Limit X upper limit	CALCulate2:LIMitX:UPPer[:DATA]
Limit X upper bit pattern	CALCulate2:LIMitX:UPPer:SOURce2
Limit X lower limit	CALCulate2:LIMitX:LOWer[:DATA]
Limit X lower bit pattern	CALCulate2:LIMitX:LOWer:SOURce2
Composite limits bit pattern	CALCulate2:CLIMits:PASS:SOURce2
Next pass memory location	CALCulate2:CLIMits:PASS:SMLocation
Trigger delay†	TRIGger:DELay
Guard type	SYSTem:GUARd

* X = CURRent or VOLTage.

** Limit X = Limit 2, 3, 5-12.

† Not available when the Model 2430 is in the Pulse Mode.

Sweep branching

When using a Source Memory Sweep while performing limit tests, the normal sequence of sweep memory points can be changed. This is useful when, based on the results of an initial test, a different set of tests are needed.

The sweep can branch to a specified memory location point, or proceed to the next memory location in the list. When a memory location is specified, the sweep will branch to that memory location if the test is successful (PASS condition). If not successful (FAIL condition), the sweep proceeds to the next memory location in the list. With NEXT selected (the default), the sweep proceeds to the next memory location in the list regardless of the outcome of the test (PASS or FAIL condition).

Figure 10-3 shows a six-point sweep branching example. In this case, the unit is programmed to branch to location 7 when a pass conditions occurs at location 3.

Figure 10-3
Six-point test branching example

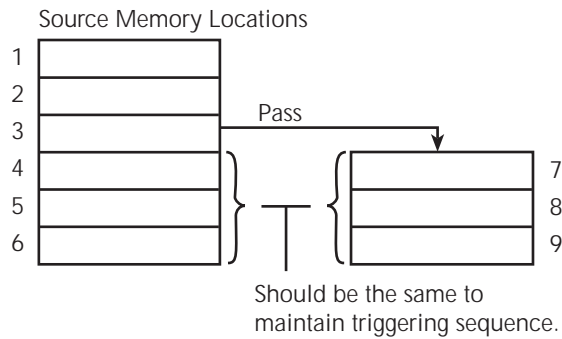

Caution must be used when branching since infinite memory loops can inadvertently be created. Also, a single Source Memory Sweep will always sweep the number of points specified, regardless of how many branches were taken.

Memory sweep branching option is set from the PASS (SRC MEM LOC) item of the CONFIG LIMITS MENU. (See [Section 12](#), “Limit Testing” and “Configuring limit tests,” for details.) Via remote, use the :CALCulate2:CLIMits:PASS:SMLocation command. (See “Configuring and running a sweep” in this section.)

NOTE Branch on fail is available via remote only with CALC2:CLIM:FAIL:SML. See [Section 18](#) for details.

Configuring and running a sweep

Front panel sweep operation

Sweep configuration menu

The sweep configuration menu is structured as follows and shown in [Figure 10-4](#). Note that bullets indicate the primary items of the sweep menu and dashes indicate the options of each menu item. Using [Section 1](#), “[Rules to navigate menus](#),” go through the following menu to select and configure the desired sweep.

CONFIGURE SWEEPS menu:

Press CONFIG then SWEEP to display the sweep configuration menu.

- TYPE — Use this menu item to select the type of sweep:
 - STAIR — When the linear staircase sweep is selected, you will be prompted to enter the START, STOP, and STEP levels.
 - LOG — When the logarithmic staircase sweep is selected, you will be prompted to enter the START and STOP levels and specify the number of measurement points.
 - CUSTOM — With the custom sweep selected, you specify the number of measurement points (# POINTS) in the sweep and the source level at each point (ADJUST POINTS). With the INIT option, you can set a consecutive range of measurement points in the sweep to a specific level. For example, assume that for a 20-point custom voltage sweep (# POINTS = 20), you want points 10 through 15 to be set for 1V. After selecting the INIT option, set the VALUE to +1.000000V, set the START PT to 10, and set the STOP PT to 15.
 - SRC MEMORY — With the Source Memory Sweep selected, you specify the memory location START point to start the sweep (1 is the default) and the number of memory location points (# POINTS) in the sweep. When configured to sweep past point 100, the sweep automatically wraps around to point 1.
- SWEEP COUNT — Use this menu item to specify how many sweeps to perform:
 - FINITE — Use this option to enter a discrete number of sweeps to perform with the results stored in the data store buffer. The maximum number of finite sweeps that can be performed is determined as follows:
 - maximum finite sweep count = $2500 / \# \text{ Points in sweep}$
 - INFINITE — Select this option to continuously repeat the configured sweep. Use the EXIT key to stop the sweep. Data is not stored in the buffer.

- SOURCE RANGING — Use this menu item to control source ranging (ignored in source memory):
 - BEST FIXED — With this option, the SourceMeter will select a single fixed source range that will accommodate all of the source levels in the sweep. For example, if the minimum and maximum source levels in the sweep for the Model 2400 are 1V and 30V, the 200V source range will be used.
 - AUTO RANGE — With this option, the SourceMeter will select the most sensitive source range for each source level in the sweep. For example, for a 1V source level, the 2V source range will be used, and for a 3V source level, the 20V source range will be used. Note that the range changing process of AUTO RANGE may cause transients in the sweep. If these transients cannot be tolerated, use the BEST FIXED source range.
 - FIXED — With this option, the source remains on the range presently on when the sweep is started. For sweep points that exceed the source range capability, the source will output the maximum level for that range. For example, if the source is on the 2V range when the sweep is started, it will remain on the 2V range for the entire sweep. If the configured sweep points are 1V, 2V, 3V, 4V, and 5V, the sweep will be 1V, 2V, 2.1V, 2.1V, and 2.1V.
- COMPLIANCE ABORT — Use this option to control abort on compliance, which will abort a sweep in progress if compliance is detected:
 - NEVER — This selection disables abort on compliance.
 - EARLY — Abort sweep if compliance is detected at the beginning of the SDM cycle.
 - LATE — Abort sweep if compliance is detected at the end of the SDM cycle.

Figure 10-4
Sweep configuration menu tree

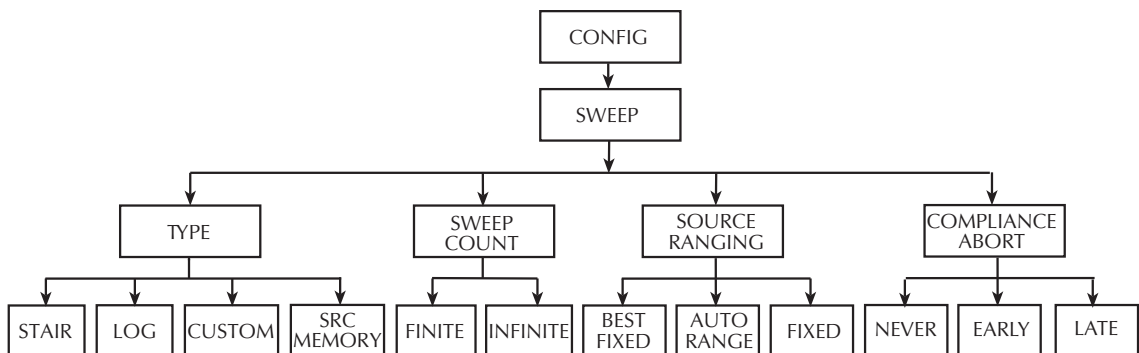

Setting delay

Generally, the time duration spent at each step (or point) of a sweep consists of the source delay and the time it takes to perform the measurement (NPLC setting).

NOTE For the Model 2430 Pulse Mode, source delay is not used. Instead, pulse width (for the on-time) and pulse delay (for the off-time) are the delays that are set by the user. Pulse Mode sweeps are covered later in this section.

The source delay is part of the SDM cycle and is used to allow the source to settle before the measurement is made. (See [Section 6](#), “[Source-delay-measure cycle](#),” for details).

The total time period of the source delay could include an auto-delay and/or a user programmed delay. With auto-delay enabled, 1ms of delay is used. The user programmable source delay adds 0000.0000 to 9999.9990 seconds of delay. See [Section 3](#), “[Source delay](#),” to set these delays).

Additional delay for a sweep is available by using the trigger delay. This user-specified delay (0000.0000 to 9999.99990 seconds) occurs before each SDM cycle (device action) of the sweep. Thus, the trigger delay is executed before each new source-point in the sweep. See [Section 11](#), “[Trigger models](#)” and “[Configuring triggering](#),” to set trigger delay.

NOTE For linear staircase, log staircase, and custom sweeps, source delay, trigger delay, and NPLC settings are global and affect all sweep points simultaneously. For source memory sweep only, both the source delay and NPLC settings can be set to different values for each point in the sweep.

Trigger count and sweep points

The trigger count and number of sweep points should be the same or multiples of one another. For example, with five sweep points and a trigger count of 10, the sweep will run twice. See [Section 11](#) for details on trigger count.

Performing sweeps

Procedures for the various sweep types are covered below.

NOTE For the Model 2430, the following procedure assumes that the DC mode of operation is selected (“Vsrc” or “Isrc” displayed in source field). If in the Pulse Mode (“Vpls” or “Ipls” displayed), you can return to the DC Mode

by pressing CONFIG V or I, selecting the SHAPE menu item, and then selecting PULSE. Use the EXIT key to back out of the menu.

The following procedure assumes that the SourceMeter is already connected to the DUT as explained in [Section 2](#).

WARNING Hazardous voltages ($\geq 30\text{V rms}$) can appear on the selected INPUT/OUTPUT LO terminal when performing fast pulse sweep operations. To eliminate this shock hazard, connect the LO terminal to earth ground. If using the front panel terminals, ground the front panel LO terminal. If using the rear panel terminals, ground the rear panel LO terminal. The ground connection can be made at the chassis ground screw on the rear panel or to a known safety earth ground.

Performing a staircase sweep

Step 1: Configure source-measure functions.

Configure the SourceMeter for the desired source-measure operations as follows:

1. Select the desired source function by pressing SOURCE V or SOURCE I.
2. Set the source level and compliance limit to the desired values.
3. Press MEAS V or MEAS I to select the desired measurement function, then choose the desired measurement range.

Step 2: Configure sweep.

Configure the sweep as follows:

1. Press CONFIG then SWEEP.
2. Select TYPE, then press ENTER.
3. Select STAIR, then press ENTER.
4. At the prompts, enter the desired START, STOP, and STEP values.
5. From the CONFIGURE SWEEPS menu, select SWEEP COUNT, press ENTER, then choose FINITE or INFINITE as desired.
6. Again from the CONFIGURE SWEEPS menu, choose SOURCE RANGING, press ENTER, then select BEST FIXED, AUTO RANGE, or FIXED as appropriate.
7. Press EXIT to return to normal display.

Step 3: Set delay.

Set the source delay as follows:

1. Press CONFIG then SOURCE V or SOURCE I depending on the selected source function.
2. Select DELAY, then press ENTER.
3. Set the delay to the desired value, then press ENTER.
4. Press EXIT to return to normal display.

Step 4: Turn output on.

Press the ON/OFF OUTPUT key to turn the output on (OUTPUT indicator turns on). The SourceMeter will output the programmed bias level.

Step 5: Run sweep.

To run the sweep, press the SWEEP key. After the sweep is completed, turn the output off by pressing the ON/OFF OUTPUT key.

Step 6: Read buffer.

Use the RECALL key to access the source-measure readings stored in the buffer. Use the TOGGLE to display statistical information. (See [Section 9](#), “Data Store.”)

Performing a custom sweep**Step 1: Configure source-measure functions.**

Configure the SourceMeter for the desired source-measure operations as follows:

1. Select the desired source function by pressing SOURCE V or SOURCE I.
2. Set the source level and compliance limit to the desired values.
3. Press MEAS V or MEAS I to select the desired measurement function, then choose the desired measurement range.

Step 2: Configure sweep.

Configure the sweep as follows:

1. Press CONFIG then SWEEP.
2. Select TYPE, then press ENTER.
3. Select CUSTOM, then press ENTER.
4. Use the displayed menu selections to enter the desired # POINTS, individual point values (ADJUST POINTS), and INIT (initial) value.
5. From the CONFIGURE SWEEPS menu, select SWEEP COUNT, press ENTER, then choose FINITE or INFINITE as desired.
6. Again from the CONFIGURE SWEEPS menu, choose SOURCE RANGING, press ENTER, then select BEST FIXED, AUTO RANGE, or FIXED as appropriate.
7. Press EXIT to return to normal display.

Step 3: Set delay.

Set the source delay as follows:

1. Press CONFIG then SOURCE V or SOURCE I depending on the selected source function.
2. Select DELAY, then press ENTER.
3. Set the delay to the desired value, then press ENTER.
4. Press EXIT to return to normal display.

Step 4: Turn output on.

Press the ON/OFF OUTPUT key to turn the output on (OUTPUT indicator turns on). The SourceMeter will output the programmed bias level.

Step 5: Run sweep.

To run the sweep, press the SWEEP key. After the sweep is completed, turn the output off by pressing the ON/OFF OUTPUT key.

Step 6: Read buffer.

Use the RECALL key to access the source-measure readings stored in the buffer. Use the TOGGLE to display statistical information.

Performing a source memory sweep**Step 1: Store setups in source memory.**

Store instrument setups in source memory as follows:

1. Configure the SourceMeter for various desired operating modes such as source, measure, delay, and/or math expression operation. See [Table 10-2](#) for settings that can be stored in each source memory location.
2. Press MENU to display the MAIN MENU:
 - Select SAVESETUP.
 - Select SOURCE MEMORY.
 - Select SAVE.
 - Use the \uparrow and \downarrow keys, and the cursor keys to display the desired memory location, and press ENTER.
 - Use the EXIT key to back out of the menu structure.
3. Repeat Steps 1 and 2 for all points in the sweep.

Step 2: Configure sweep

Configure the sweep as follows:

1. Press CONFIG then SWEEP.
2. Select TYPE, then press ENTER.
3. Select SRC MEMORY, then press ENTER.
4. Use the menu selections to enter the desired START memory location and # POINTS for the source memory sweep.
5. From the CONFIGURE SWEEPS menu, select SWEEP COUNT, press ENTER, then choose FINITE or INFINITE as desired.
6. Again from the CONFIGURE SWEEPS menu, choose SOURCE RANGING, press ENTER, then select BEST FIXED, AUTO RANGE, or FIXED as appropriate.
7. Press EXIT to return to normal display.

Step 3: Turn output on.

Press the ON/OFF OUTPUT key to turn the output on (OUTPUT indicator turns on).

Step 4: Run sweep.

To run the sweep, press the SWEEP key. After the sweep is completed, turn the output off by pressing the ON/OFF OUTPUT key.

Step 5: Read buffer.

Use the RECALL key to access the source-measure readings stored in the buffer. Use the TOGGLE to display statistical information.

Remote sweep operation

Staircase sweep commands

Table 10-3 summarizes remote commands used for linear and log staircase sweep operation. See Section 18, “Configure voltage and current sweeps,” for more details on these commands.

Table 10-3

Linear and log staircase sweep commands

Command	Description
:SOURce:CURRent:MODE SWEep	Select current source sweep mode.
:SOURce:CURRent:START <n>	Specify sweep start current (n = current).
:SOURce:CURRent:STOP <n>	Specify sweep stop current (n = current).
:SOURce:CURRent:STEP <n>	Specify sweep step current (n = current).
:SOURce:CURRent:CENTer <n>	Specify sweep center current (n = current).
:SOURce:CURRent:SPAN <n>	Specify sweep span current (n = current).
:SOURce:VOLTage:MODE SWEep	Select voltage source sweep mode.
:SOURce:VOLTage:START <n>	Specify sweep start voltage (n = voltage).
:SOURce:VOLTage:STOP <n>	Specify sweep stop voltage (n = voltage).
:SOURce:VOLTage:STEP <n>	Specify sweep step voltage (n = voltage).
:SOURce:VOLTage:CENTer <n>	Specify sweep center voltage (n = voltage).
:SOURce:VOLTage:SPAN <n>	Specify sweep span voltage (n = voltage).
:SOURce:SWEep:RANGing <name>	Select source ranging (name = BEST, AUTO, or FIXed).
:SOURce:SWEep:SPACing <name>	Select sweep scale (name = LINear or LOGarithmic).
:SOURce:SWEep:POINts <n>	Set number of sweep points (n = points).
:SOURce:SWEep:DIREction <name>	Set sweep direction. Name = UP (sweep start to stop) or DOWN (sweep stop to start).
:SOURce:SWEep:CABort <name>	Abort on compliance. Name = NEVER (disable), EARLY (start of SDM cycle), or LATE (end of SDM cycle).

Staircase sweep programming example

As an example of linear staircase sweep operation, assume the SourceMeter is to be used to generate the I-V characteristics of a diode. Many diode tests, such as breakdown voltage and leakage current, require only single-point measurements. Some, such as quality-assurance analysis of marginal parts, involve performing a complete I-V sweep for detailed analysis.

Table 10-4 lists the command sequence for the diode programming example.

Table 10-4

Staircase sweep programming example (diode test)

Command	Description
*RST	Restore GPIB default conditions.
:SENS:FUNC:CONC OFF	Turn off concurrent functions.
:SOUR:FUNC CURR	Current source function.
:SENS:FUNC 'VOLT:DC'	Volts sense function.
:SENS:VOLT:PROT 1	1V voltage compliance.
:SOUR:CURR:START 1E-3	1mA start current.
:SOUR:CURR:STOP 10E-3	10mA stop current.
:SOUR:CURR:STEP 1E-3	1mA step current.
:SOUR:CURR:MODE SWE	Select current sweep mode. ¹
:SOUR:SWE:RANG AUTO	Auto source ranging.
:SOUR:SWE:SPAC LIN	Select linear staircase sweep.
:TRIG:COUN 10	Trigger count = # sweep points. ²
:SOUR:DEL 0.1	100ms source delay.
:OUTP ON	Turn on source output.
:READ?	Trigger sweep, request data.

1. This command should normally be sent after START, STOP, and STEP to avoid delays caused by rebuilding sweep when each command is sent.
2. For single sweep, trigger count should equal number of points in sweep: Points = (Stop-Start)/Step + 1. You can use SOUR:SWE:POIN? query to read the number of points.

Custom sweep commands

Table 10-5 summarizes remote commands used for custom sweep operation. See Section 18, “Configure list,” for more details on these commands.

Table 10-5

Custom sweep commands

Command	Description
:SOURce:CURRent:MODE LIST	Select current list (custom) sweep mode.
:SOURce:VOLTage:MODE LIST	Select voltage list (custom) sweep mode.
:SOURce:LIST:CURRent <list>	Define I-source (list = I1, I2,... In).
:SOURce:LIST:CURRent:APPend <list>	Add I-source list value(s) (list =I1, I2,...In).
:SOURce:LIST:CURRent:POINts?	Query length of I-source list.
:SOURce:LIST:VOLTage <list>	Define V-source list (list = V1, V2,... Vn).
:SOURce:LIST:VOLTage:APPend <list>	Add V-source list value(s) (list =V1, V2,...Vn).
:SOURce:LIST:VOLTage:POINts?	Query length of V-source list.
:SOURce:SWEep:RANGing <name>	Select source ranging (name = BEST, AUTO, or FIXed).

Custom sweep programming example

Table 10-6 summarizes the basic remote command sequence for performing a custom sweep.

Table 10-6

Custom sweep programming example

Command	Description
*RST	Restore GPIB default conditions.
:SENS:FUNC:CONC OFF	Turn off concurrent functions.
:SOUR:FUNC VOLT	Volts source function.
:SENS:FUNC 'CURR:DC'	Current sense function.
:SENS:CURR:PROT 0.1	100mA current compliance.
:SOUR:VOLT:MODE LIST	List volts sweep mode.
:SOUR:LIST:VOLT 7,1,3,8,2	7V, 1V, 3V, 8V, 2V sweep points.
:TRIG:COUN 5	Trigger count = # sweep points.
:SOUR:DEL 0.1	100ms source delay.
:OUTP ON	Turn on source output.
:READ?	Trigger sweep, request data.

Source memory sweep commands

Table 10-7 summarizes remote commands used for custom sweep operation. See Section 18, “Configure memory sweep,” for more details on these commands.

Table 10-7

Source memory sweep commands

Command	Description
:SOURce:FUNctIon MEM	Select memory sweep mode.
:SOURce:MEMory:POINts <n>	Specify number of sweep points (n = points).
:SOURce:MEMory:STARt <n>	Select source memory start location (n = location).
:SOURce:MEMory:RECall <n>	Return to specified setup (n = memory location).
:SOURce:SAVE <n>	Save setup in memory (n = memory location).
:SENSe:CURRent:RANge:HOLDoff 	Enable (ON), disable (OFF) current range holdoff.
:SENSe:CURRent:RANge:HOLDoff:DELay <NRf>	Set holdoff delay in seconds.

Source memory sweep programming example

Table 10-8 summarizes the basic remote command sequence for performing the basic source memory sweep.

Table 10-8

Source memory sweep programming example

Command	Description
*RST	Restore GPIB default conditions.
:SENS:FUNC:CONC OFF	Turn off concurrent functions.
:SOUR:FUNC MEM	Source memory sweep mode.
:SOUR:MEM:POIN 3	Number memory points = 3.
:SOUR:MEM:STAR 1	Start at memory location 1.
:SOUR:FUNC VOLT	Volts source function.
:SENS:FUNC 'CURR:DC'	Current sense function.
:SOUR:VOLT 10	10V source voltage.
:SOUR:MEM:SAVE 1	Save in source memory location 1.
:SOUR:FUNC CURR	Current source function.
:SENS:FUNC 'VOLT:DC'	Volts sense function.
:SOUR:CURR 100E-3	100mA source current.
:SOUR:MEM:SAVE 2	Save in source memory location 2.
:SENS:FUNC 'CURR:DC'	Current sense function.
:SOUR:MEM:SAVE 3	Save in source memory location 3.
:TRIG:COUN 3	Trigger count = # sweep points.
:OUTP ON	Turn on source output.
:READ?	Trigger sweep, request data.

Pulse Mode sweeps (Model 2430 only)

When performing a sweep with the Model 2430 in the Pulse Mode, each step or point of the sweep is made up of a pulse period. In general, a pulse period consists of the pulse width (output on-time) and the output off-time. [Figure 10-5](#) shows an example of a 3-step linear staircase sweep for the Pulse Mode (start = 1V, stop = 3V, step = 1V). A measured reading is performed for each of the three pulse steps. Readings are not performed for the output off-times.

For normal (DC Mode) sweep operation, the time duration spent on each step consists of the set source delay and the time it takes to perform the measurement. For the Pulse Mode, source delay is not used. The pulse width consists of the pulse width delay, internal overhead time and the pulse signal measurement. The output off-time typically consists of zero and reference measurements (used to calculate accurate pulse readings), internal overhead time, and an optional pulse delay.

NOTE *Details on Pulse Mode operation for the Model 2430 are provided in [Section 5](#).*

Figure 10-5
Pulse Mode linear staircase sweep

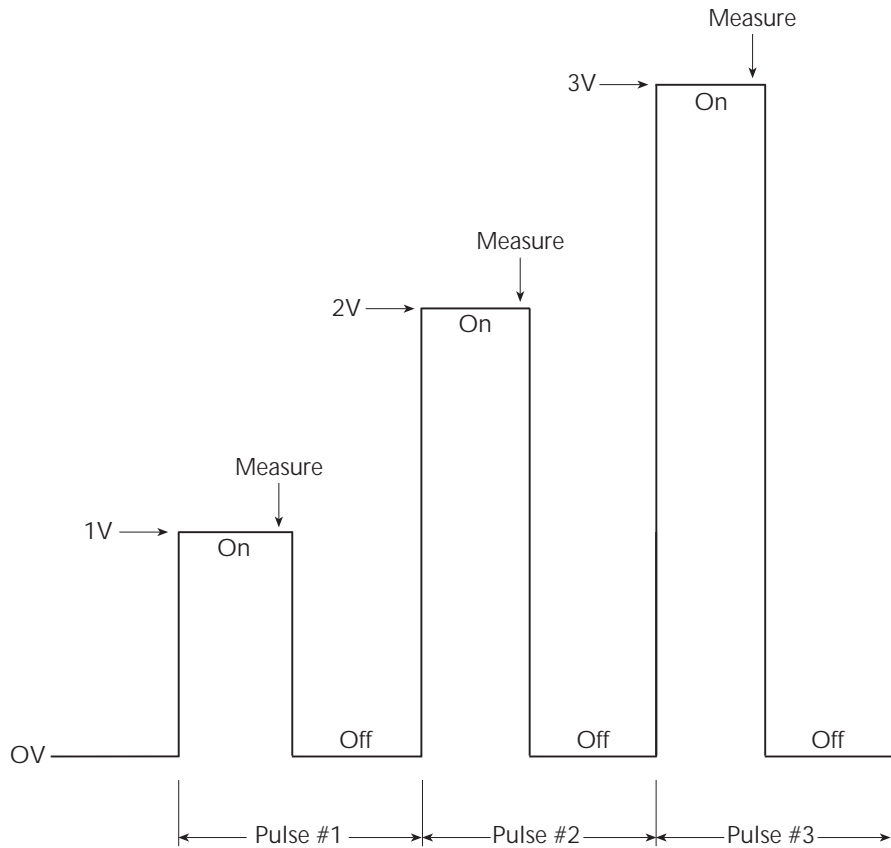

Front panel Pulse Mode sweep procedure

The procedure to perform a Pulse Mode sweep is summarized as follows:

NOTE The following procedure assumes that the Model 2430 is already connected to the DUT as explained in [Section 2](#).

WARNING Hazardous voltages ($\geq 30\text{V rms}$) can appear on the selected INPUT/OUTPUT LO terminal when performing fast pulse sweep operations. To eliminate this shock hazard, connect the LO terminal to earth ground. If using the front panel terminals, ground the front panel LO terminal. If using the rear panel terminals, ground the rear panel LO terminal. The ground connection can be made at the chassis ground screw on the rear panel or to a known safety earth ground.

Step 1: Select and configure pulse mode

Basic parameters for the Pulse Mode include pulse width, pulse delay, pulse measurement speed, and pulse count. Refer to [Section 5, “Pulse Mode configuration,”](#) to select the Pulse Mode and set the pulse parameters.

Step 2: Set compliance limit, and select measurement function and range.

Configure the Model 2430 for these aspects of operation as explained in steps 1 through 3, [Section 3, “Basic source-measure procedure.”](#)

Note that the AUTO measurement range is not valid in the Pulse Mode. Make sure the fixed measurement range that you select can accommodate every measurement point in the sweep.

Step 3: Configure sweep.

Select and configure the sweep as explained in [“Configuring and running a sweep.”](#)

Step 4: Run sweep.

To run the sweep, press the SWEEP key. After the last pulse in the sweep is sourced, the output will turn off and stay off. A sweep that is in progress can be stopped at any time by pressing the ON/OFF OUTPUT key or the EXIT key.

Step 5: Read buffer.

Use the RECALL key to access the source-measure readings stored in the buffer. Use the TOGGLE to display statistical information. (See [Section 9, “Data Store.”](#))

Remote Pulse Mode sweep operation

The commands for Pulse Mode operation are provided in [Section 5](#), while the staircase sweep commands are provided in [Table 10-3](#).

Table 10-9 provides a typical remote command sequence for performing the 3-point Pulse Model linear staircase sweep shown in Figure 10-5.

Table 10-9

Pulse Mode linear staircase sweep programming example

Command	Description
*RST	Restore GPIB default conditions.
:SOUR:FUNC PULS	Select Pulse Mode.
:SOUR:PULS:WIDT 0.005	5ms pulse width.
:SOUR:PULS:DEL 0.003	3ms pulse delay.
:SENS:VOLT:NPLC 0.1	Measure speed = 0.1 PLC. ¹
:TRIG:COUN 3	Pulse count = # sweep points. ²
:SOUR:FUNC VOLT	Volts source function. ¹
:SENS:FUNC 'CURR'	Current sense function. ¹
:SENS:CURR:PROT 0.1	100mA current compliance.
:SOUR:VOLT:START 1	1V start voltage.
:SOUR:VOLT:STOP 3	3V stop voltage.
:SOUR:VOLT:STEP 1	1V step voltage.
:SOUR:VOLT:MODE SWE	Select volts sweep mode. ³
:READ?	Trigger sweep, request data.

1. These commands are not required in this case, since unit assumes these operating states after *RST but are included to demonstrate complete programming steps.
2. Trigger count should equal number of points in sweep:
Points = (Stop-Start)/Step + 1.
You can use SOUR:SWE:POIN? query to read the number of points.
3. This command should normally be sent after START, STOP, and STEP to avoid delays caused by rebuilding sweep when each command is sent.

11

Triggering

- **Front panel trigger operation** — Discusses front panel triggering including the trigger model, various layers, event detection, delay, and device action, and front panel trigger configuration.
- **Remote trigger operation** — Details the remote trigger model and summarizes trigger commands.
- **Trigger link** — Discusses the trigger link, including input triggers and output triggers.
- **Pulse Mode triggering (Model 2430)** — Explains the triggering differences between the DC Mode and Pulse Mode of the Model 2430.

Front panel trigger operation

Front panel trigger model

NOTE For the Model 2430, the following discussion on the trigger model pertains explicitly to the DC Mode of operation. The trigger model operates a little differently for the Pulse Mode. These differences are covered in [“Pulse Mode triggering \(Model 2430\)”](#) later in this section.

NOTE For instruments with the contact check option, see [Appendix F](#) for details on trigger operation.

The flowchart in [Figure 11-1](#) summarizes triggering for front panel operation. The trigger model is modeled after the remote commands used to control triggering. (See [“Remote trigger commands,”](#) [page 11-18.](#)) Key trigger model settings are included in the flowchart. Note that the BENCH defaults are denoted by the “” symbol.

The primary actions of the trigger model are Source, Delay, and Measure. The source action outputs the programmed voltage or current value, and the programmed delay provides a settling period for the source before the measurement is performed.

The trigger model consists of two layers (Arm Layer and Trigger Layer) to provide versatility. Programmable counters allow operations to be repeated, and various input and output trigger options are available to provide source-measure synchronization between the SourceMeter and other instruments (via the Trigger Link).

Unless otherwise noted, the programmable aspects of the trigger model are performed from the CONFIGURE TRIGGER menu. (See [“Configuring triggering,”](#) [page 11-7.](#))

Event detection

In general, operation is held up at an Event Detector until the programmed event occurs. Note however, that if an event detector has a bypass, operation can be programmed to loop around the event detector.

Idle

The SourceMeter is in idle when it is not operating in the Arm Layer or Trigger Layer of the trigger model. When in idle, the ARM annunciator is off. To take the SourceMeter out of idle, turn the output ON.

The SourceMeter can be returned to idle at any time by selecting the HALT menu item of the CONFIGURE TRIGGER menu. (See [“Configuring triggering,”](#) [page 11-7.](#))

Figure 11-1
Front panel trigger model

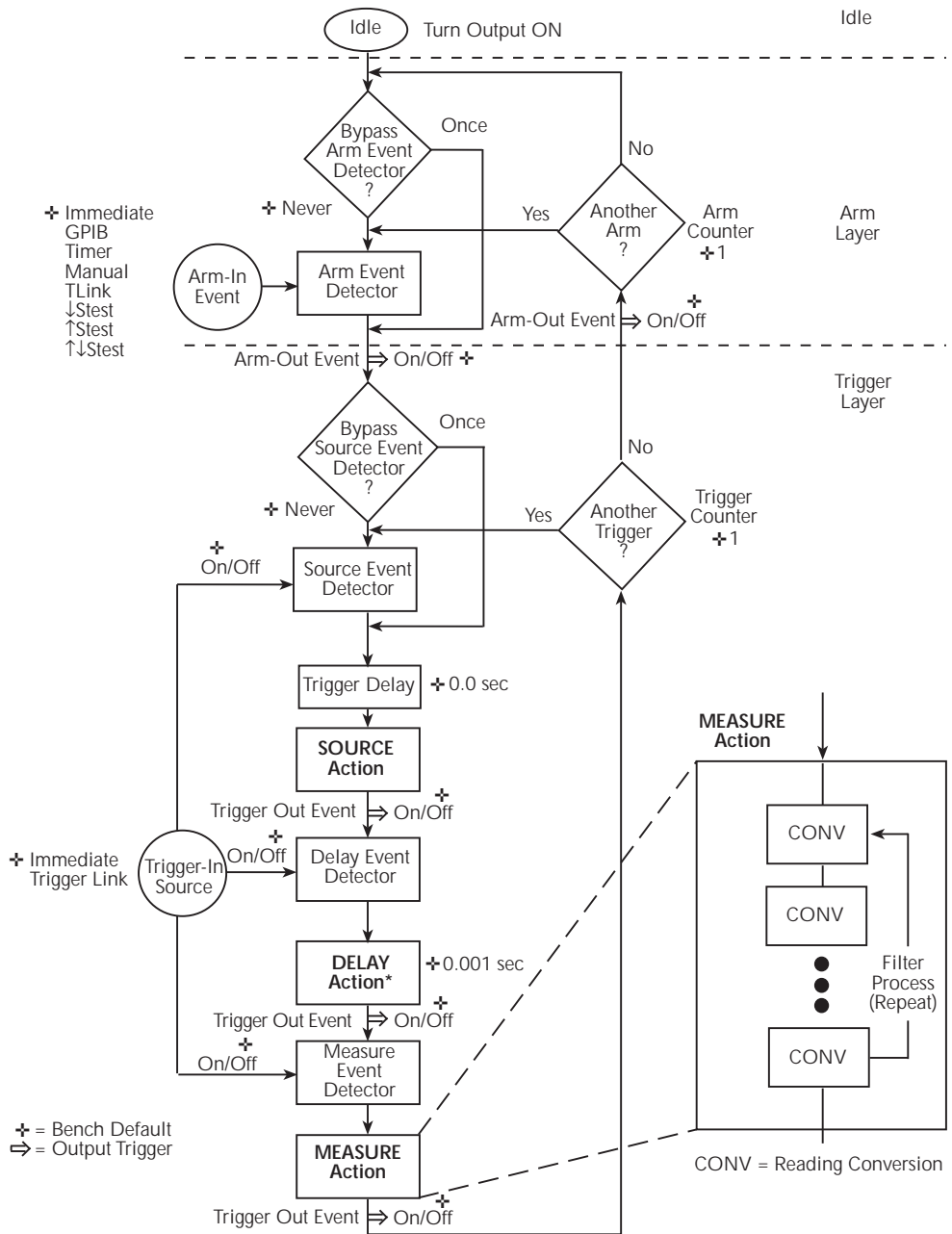

* Soak time takes the place of the delay time only during the first SDM cycle after initial sweep trigger if the unit is in the MULTIPLE mode. See Section 7, "Autorange change mode."

Arm layer

Event Detector Bypass — As shown in [Figure 11-1](#), there is a bypass for the Arm Event Detector. This bypass can only be used if TLINK or STEST is the selected Arm-In Event. The bypass serves to “jump-start” operation. With the event detector bypass set to ONCE, operation will loop around the Arm Event Detector when the output is turned ON.

The programmable arm-in events for the Arm Layer are described as follows:

IMMEDIATE — Event detection occurs immediately allowing operation to continue.

GPIB — Event detection occurs when a bus trigger (GET or *TRG) is received.

TIMER — With the Timer selected, event detection occurs immediately when the output is turned ON. On repeated passes via “Another Arm ? Yes,” event detection occurs when the programmed timer interval expires. If operation takes the “Another Arm ? No” route, the Timer resets allowing event detection to again occur immediately.

MANUAL — Event detection occurs when the TRIG key is pressed.

TLINK — Event detection occurs when an input trigger via the Trigger Link input line is received. See “[Trigger link](#)” later in this section for more information. With TLink selected, you can loop around the Arm Event Detector by setting the event detector bypass to ONCE.

↓STEST — Event detection occurs when the start-of-test (SOT) line of the Digital I/O port is pulsed low. This pulse is received from the handler to start limit testing. See [Section 12](#).

↑ STEST — Event detection occurs when the start-of-test (SOT) line of the Digital I/O port is pulsed high. This pulse is received from the handler to start limit testing. See [Section 12](#).

↑ ↓STEST — Event detection occurs when the start-of-test (SOT) line of the Digital I/O port is pulsed either high or low. This pulse is received from the handler to start limit testing. See [Section 12](#).

NOTE *STEST can be used only at the beginning of a sweep and should not be used to trigger each point in a sweep.*

Trigger layer

The Trigger Layer uses three event detectors; one for each action (Source, Delay, and Measure). Each of these event detectors can be turned on or off individually.

Event Detector Bypass — As shown in [Figure 11-1](#), there is a bypass for the Source Event Detector. This bypass is in effect only if Trigger Link is the selected Trigger-In Source. With this event detector bypass set to ONCE, operation will proceed around the Source Event Detector.

The programmable trigger-in sources for the Trigger Layer are described as follows:

IMMEDIATE — With Immediate selected, event detection for the three detectors is satisfied immediately. Operation proceeds through the Trigger Layer to perform the Source, Delay, and Measure actions.

TRIGGER LINK — With Trigger Link selected, event detection at each enabled detector occurs when an input trigger via the Trigger Link input line is received. (See “[Trigger link](#),” [page 11-19](#).) For example, if the Trigger In Event for the Source Event Detector is ON, operation will hold up at that detector until an input trigger is received. If, however, the Source Event Detector is disabled (OFF), operation will not hold up. Operation will continue and perform the Source action.

With the Trigger Link Trigger-In Source selected, operation will go around the Source Event Detector (as shown in [Figure 11-1](#)) by setting the event detector bypass to ONCE.

Trigger delay

A programmable delay is available before the Source Action. The Trigger Delay can be manually set from 0.00000 to 999.99990 seconds. Note that this delay is separate from the Delay Action of the SDM cycle. The Delay Action is discussed next.

Source, delay, and measure actions

The SDM cycle of the SourceMeter consists of three actions: Source, Delay, and Measure:

SOURCE Action — Any programmed output voltage or current level changes are performed.

DELAY Action — This programmable delay is used to allow the source to settle before a measurement is performed. It can be manually set from 0.00000 to 9999.99900 seconds, or Auto Delay can be enabled. With Auto Delay enabled, the SourceMeter automatically selects a nominal delay period based on the selected function and range.

NOTE The Delay Action is set from the CONFIGURE V-SOURCE or CONFIGURE I-SOURCE menu. See [Section 3](#), “Source delay.”

In MULTIPLE mode, the soak time takes the place of the delay time only during the first SDM cycle after the initial sweep trigger. See [Section 7](#), “Auto range change mode.”

MEASURE Action — During this phase of the SDM cycle, the measurement process takes place. If the repeat filter is enabled, as shown in the blow-up drawing for Measure Action, the instrument samples the specified number of reading conversions to yield a single filtered reading (measurement). If using the moving filter or if the filter is disabled, only a single reading conversion will yield a reading.

Counters

Programmable counters are used to repeat operations within the trigger model layers. For example, if performing a 10-point sweep, the trigger counter would be set to 10. Operation will stay in the Trigger Layer until the 10 source-delay-measure points of the sweep are performed.

If you wanted to repeat the sweep three times, the arm counter would be set to three. Three 10-point sweeps can then be performed for a total of 30 source-delay-measure actions. Refer to the examples at the end of this section.

The maximum buffer size for the SourceMeter is 2500 readings. The product of the two counter values cannot exceed 2500. For example, if you set an arm count of two, the maximum trigger count will be 1250 ($2500 / 2 = 1250$). However, you can set the arm count to INFINITE. With an infinite arm count, the maximum trigger count is 2500.

NOTE When a sweep is configured, the trigger model settings will not change until the sweep is started. After the sweep is finished, the trigger model will reset to the previous settings.

Output triggers

The SourceMeter can be programmed to output a trigger (via rear panel Trigger Link connector) after various trigger model operations. An output trigger is used to trigger another instrument to perform an operation. See “[Trigger link](#),” [page 11-19](#), for more information.

Trigger Layer Output Triggers — After each action (Source, Delay, and Measure), the SourceMeter can be programmed to send out an output trigger if Trigger Link is the selected Trigger-In Source. For example, if the Trigger Out Event for Measure is ON, an output trigger will be sent after the Measure action. When used with a scanner, an output trigger after each measurement can signal the scanner to select the next channel in the scan.

NOTE When using SourceMeter autoranging, it is recommended that you use measure output triggers to avoid erroneous results.

Arm Layer Output Trigger — The SourceMeter can also be programmed to output a trigger when operation enters the Trigger Layer, or after operation leaves the Trigger Layer and enters back into the Arm Layer. This output trigger is typically sent to another instrument to signal the end of a scan or sweep.

Bench defaults

The bench defaults are listed as follows. They are also denoted in [Figure 11-1](#) by the “+” symbol.

- Arm-In Event = Immediate
- Trigger-In Source = Immediate
- Arm Count = 1
- Trigger Count = 1
- Trigger Delay = 0.0 sec
- Delay Action = 0.001 sec
- Source Trigger In Event = On
- Delay Trigger In Event = Off
- Measure Trigger In Event = Off
- Trigger Out Events = All Trigger Out Events are disabled (off)
- Arm Out Event = Off
- Event Detection Bypasses = Never (both layers)

When the output is turned ON, the SourceMeter will run in a continuous loop around the trigger model. After each Measure Action, operation will continue at the top of the trigger model. The SourceMeter can be returned to idle by turning the output OFF.

Configuring triggering

Trigger configuration menu

Press CONFIG and then TRIG to display the trigger configuration menu, which is outlined below and shown in [Figure 11-2](#). Note that bullets indicate the primary items of the menu, while dashes and slashes indicate options. Use [Section 1](#), “[Rules to navigate menus](#),” to check and/or change trigger options.

- **ARM LAYER** — Use this menu item to configure the arm layer of the trigger model:
 - ARM IN — Use to select the detection event for the arm layer:
 - / IMMEDIATE — Event detection occurs immediately.

- / GPIB — Event detection occurs when a bus trigger (GET or *TRG) is received.
- / TIMER — Initially, event detection is satisfied immediately. Subsequent event detection occurs after the timer interval elapses. After selecting this arm event, you will be prompted to specify the timer interval (in seconds).
- / MANUAL — Event detection occurs when the TRIG key is pressed.
- / TLINK — After selecting this arm event, you will be prompted to select the input line for the Trigger Link and the state of the event detection bypass. With ONCE selected, operation will loop around the arm event detector on each new pass through the trigger model. With NEVER selected, operation always waits for the input trigger.
- / ↓STEST — Event detection occurs when the SOT line of the Digital I/O port is pulsed low. After selecting this arm event, you will be prompted to select the state of the event detection bypass. With ONCE selected, operation will loop around the arm event detector on each new pass through the trigger model. With NEVER selected, operation always waits for the input trigger.
- / ↑STEST — Event detection occurs when the SOT line of the Digital I/O port is pulsed high. After selecting this arm event, you will be prompted to select the state of the event detection bypass.
- / ↑↓STEST — Event detection occurs when the SOT line of the Digital I/O port is pulsed either high or low. After selecting this arm event, you will be prompted to select the state of the event detection bypass.
- ARM OUT — Use to configure the arm layer output trigger:
 - / LINE — Select the Trigger Link line for the output trigger: line #1, #2, #3, or #4.
 - / EVENTS — Enable (ON) or disable (OFF) the arm layer output triggers. TRIG LAYER EXIT ON enables an output trigger on exiting the trigger layer, while TL ENTER ON enables a trigger on entering the trigger layer.
 - / COUNT — Specify the arm count, FINITE (programmable count) or INFINITE (never ending count).
- **TRIG LAYER** — Use this menu item to configure the trigger layer of the trigger model:
 - TRIGGER IN — Use to select the detection event for the trigger layer:
 - / IMMEDIATE — Event detection occurs immediately.
 - / TRIGGER LINK — After selecting this trigger-in source, you will be prompted in sequence as follows:

- > TRIG-IN TLINK LINE — Select the input line (#1, #2, #3, or #4) for the Trigger Link.
- > EVENT DETECT BYPASS — Set the bypass for the Source Event Detector. With ONCE, operation will loop around the Source Event Detector. With NEVER selected, operation will wait for an input trigger.
- > TRIGGER IN EVENTS — Enable (ON) or disable (OFF) trigger-in events (SOURCE, DELAY, and MEASURE). With a trigger-in event ON, operation will wait at that event for an input trigger. With the trigger-in event OFF, operation will not wait. It will simply continue and perform the appropriate action.

NOTE For the Model 2430 Pulse Mode, the DELAY and MEASURE events are not used. Therefore, the settings for those events are ignored.

- TRIGGER OUT — Use to configure the trigger layer output trigger:
 - / LINE — Select the Trigger Link line for the output trigger; line #1, #2, #3, or #4.
 - / EVENTS — Enable (ON) or disable (OFF) output triggers that occur after the source, delay, and measure actions.

NOTE For the Model 2430 Pulse Mode, an output trigger can only occur after the measure action. Therefore, the output trigger settings for the source and delay actions are ignored.

- DELAY — Specify the time delay (in seconds) for the trigger delay.

NOTE For the Model 2430 Pulse Mode, trigger delay is not used. Therefore, the trigger delay setting is ignored.

- COUNT — Specify the trigger count.
- HALT — Use to return the SourceMeter to the idle state. HALT does not turn off the output. The programmed source level will still be available at the OUTPUT terminals. The following actions will take the SourceMeter out of idle:
 - Turn the output off and then on again.
 - Re-select the arm or trigger event.
 - Exit from the menu structure, and then re-enter it by pressing CONFIG and then TRIG.

Figure 11-2
Trigger configuration menu tree

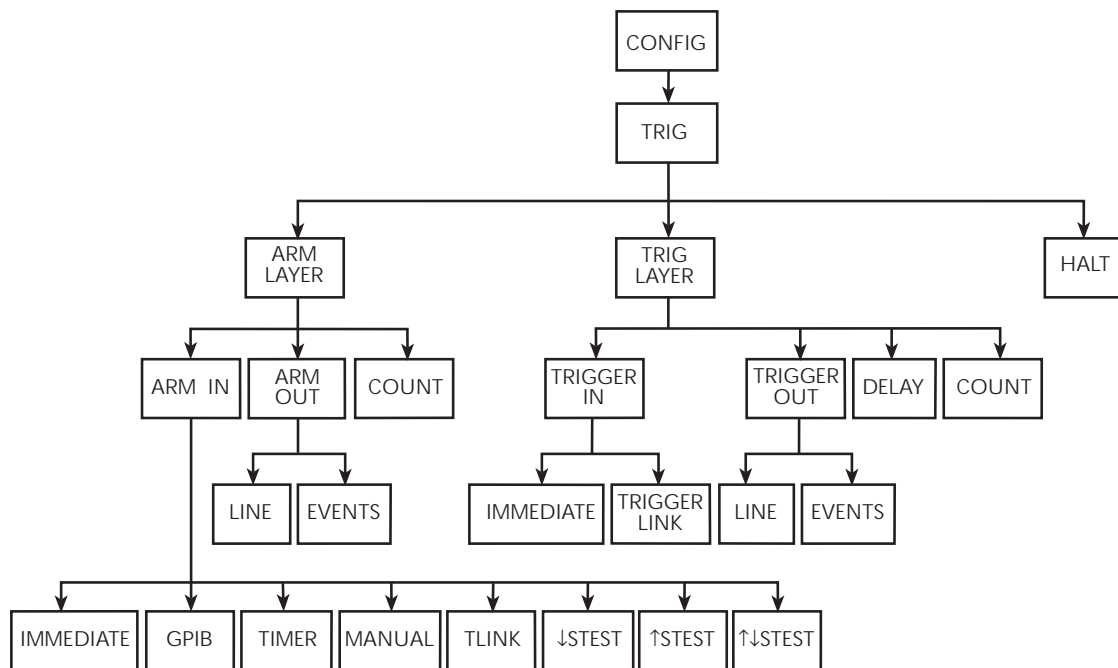

Remote trigger operation

NOTE For the Model 2430, the following discussion on the remote triggering pertains explicitly to the DC Mode of operation. The trigger model operates a little different for the Pulse Mode. These differences are covered in [“Pulse Mode triggering \(Model 2430\),”](#) page 11-20.

NOTE For instruments with the contact check option, see [Appendix F](#) for details on trigger operation.

Remote trigger model

The trigger model flowchart in [Figure 11-3](#) summarizes remote trigger operation. (The flowchart is essentially the same as the one for front panel operation shown in [Figure 11-1](#) except that remote commands to program the various trigger parameters are shown on this diagram.) Operation is controlled by SCPI com-

mands from the Trigger Subsystem. Key remote commands are included in the trigger model. Also note that the GPIB defaults are denoted by the “✚” symbol.

The primary actions of the trigger model are Source, Delay, and Measure. The source action outputs the programmed voltage or current value, and the programmed delay provides a settling period for the source before the measurement is performed.

The trigger model consists of two layers (Arm Layer and Trigger Layer) to provide versatility. Programmable counters allow operations to be repeated, and various input and output trigger options are available to provide source-measure synchronization between the SourceMeter and other instruments (via the Trigger Link).

Idle and initiate

The instrument is considered to be in the idle state (ARM annunciator off) when it is not operating within the trigger model layers. While in the idle state, the instrument cannot perform any measurements. An initiate command is required to take the instrument out of idle. The following commands perform an initiate operation:

- :INITiate
- :READ?
- :MEASure?

Conversely, if the unit is taking readings, most commands (except DCL, SDC, IFC, and ABORt) are queued up and will not be executed until the unit returns to idle.

When auto output-off is disabled (:SOURce1:CLEar:AUTO OFF), you must first turn the source output on before sending the :INITiate or :READ? command. The :MEASure? command will automatically turn the output on. Note that after the instrument returns to the idle state, the output will remain on.

When auto output-off is enabled (:SOURce1:CLEar:AUTO ON), any of the above three commands can be used to initiate operation. The source output will automatically turn on at the beginning of each SDM (source-delay-measure) cycle and turn off after each measurement is completed.

Figure 11-3
Remote trigger model

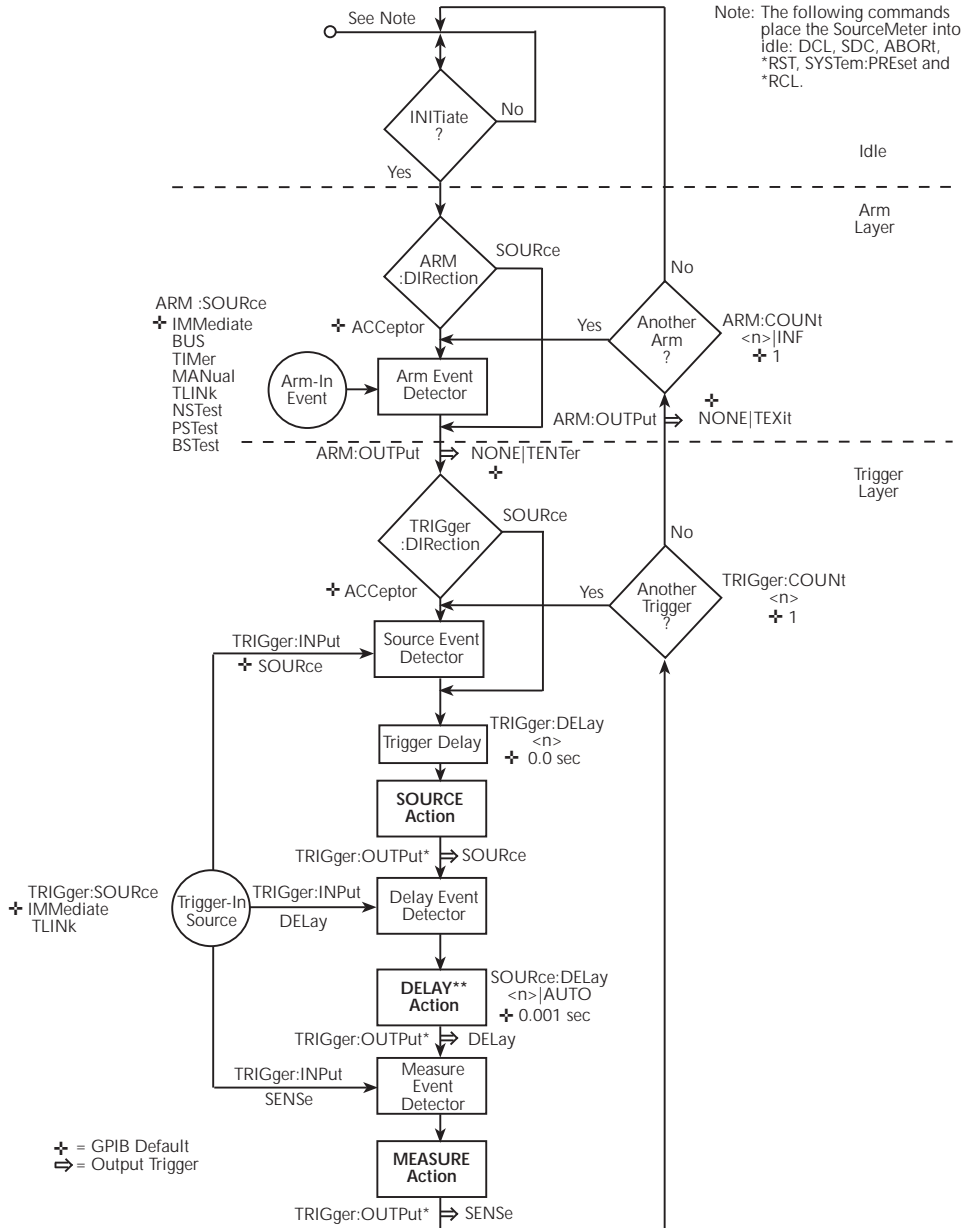

* GPIB default parameter for TRIGGER:OUTPut is NONE.

** In :SYSTem:RCMode MULTiple, the soak time programmed with :SOURce[1]:SOAK takes the place of the delay time only during the first SDM cycle after the initial sweep trigger. See Section 17 for details.

While operating within the trigger model (ARM indicator on), most commands will not be executed until the SourceMeter completes all of its programmed source-measure operations and returns to the idle state. The IFC (interface clear), SDC (selected device clear) and DCL (device clear) commands can be executed under any circumstance while operating within the trigger model. They will abort any other command or query.

- :ABORt
- :SYSTem:PRESet
- *TRG or GET
- *RST
- *RCL

NOTE SDC, DCL, or :ABORt place the SourceMeter in the idle state. For fastest response, use SDC or DCL to return to idle.

Event detection

Once the instrument is taken out of idle, operation proceeds through the trigger model to perform the Source, Delay, and Measure actions.

In general, operation is held up at an event detector until the programmed event occurs. Note however, that if an event detector has a bypass (:DIRection), operation can be programmed to loop around the event detector.

Arm layer

Event Detector Bypass — As shown in [Figure 11-3](#), there is a bypass (ARM:DIRection) for the Arm Event Detector. This bypass can only be used if TLINK, NSTest, PSTest, or BSTest is the selected Arm-In Event. The bypass serves to “jump-start” operation. With the bypass set to SOURce, operation will loop around the Arm Event Detector when an INITiate command is sent (assuming the output is turned ON).

The programmable arm-in events for the Arm Layer are described as follows:

IMMEDIATE — Event detection occurs immediately allowing operation to continue.

BUS — Event detection occurs when a bus trigger (GET or *TRG) is received.

TIMER — Event detection occurs immediately on the initial pass through the trigger model. Each subsequent detection is satisfied when the programmed timer interval elapses. The timer resets to its initial state when the instrument goes into idle.

MANUAL — Event detection occurs when the TRIG key is pressed. The SourceMeter must be in LOCAL mode for it to respond to the TRIG key. Press the LOCAL key or send LOCAL 24 over the bus to take the SourceMeter out of remote.

TLINK — Event detection occurs when an input trigger via the Trigger Link input line is received. See “[Trigger link](#),” [page 11-19](#), for more information. With TLINK selected, you can loop around the Arm Event Detector by setting the event detector bypass (ARM:DIRection) to SOURce.

NSTest — Event detection occurs when the start-of-test (SOT) line of the Digital I/O port is pulsed low. This pulse is received from the handler to start limit testing. (See [Section 12](#), “[Limit Testing](#),” and [Section 13](#), “[Digital I/O port](#).”)

PSTest — Event detection occurs when the start-of-test (SOT) line of the Digital I/O port is pulsed high. This pulse is received from the handler to start limit testing. (See [Section 12](#), “[Limit Testing](#),” and [Section 13](#), “[Digital I/O port](#).”)

BSTest — Event detection occurs when the start-of-test (SOT) line of the Digital I/O port is pulsed either high or low. This pulse is received from the handler to start limit testing. See [Section 12](#) and [Section 13](#).

NOTE NSTest, PSTest, and BSTest can be used only at the beginning of a sweep and should not be used to trigger each point in a sweep.

Trigger layer

The Trigger Layer uses three event detectors; one for each action (Source, Delay, and Measure).

Event detector bypass — As shown in [Figure 11-3](#), there is a bypass (TRIGger:DIRection) for the Source Event Detector. This bypass is in effect only if TLINK is the selected Trigger-In Source. With this event detector bypass set to SOURce, operation will proceed around the Source Event Detector.

The programmable trigger-in sources for the Trigger Layer are described as follows:

IMMediate — With Immediate selected, event detection for the three detectors is satisfied immediately. Operation proceeds through the Trigger Layer to perform the Source, Delay, and Measure actions.

TLINK — With TLINK selected, event detection at each enabled detector occurs when an input trigger via the Trigger Link input line is received. A detector is enabled by including its parameter name with the TRIGger:INPut command.

For example, to enable the Delay Event Detector and Measure Event Detector, the following command must be sent:

```
TRIGger:INPut DELay, SENSE
```

The above command disables the Source Event Detector since its parameter name (SOURce) is not included in the parameter list.

With the Source Event Detector disabled, operation will not hold up. It will continue and perform the Source Action. Operation will hold up at the Delay Event

Detector until an input trigger is received, and then it will hold up at the Measure Event Detector until another input trigger is received.

Trigger delay

A programmable delay is available before the Source Action. The Trigger Delay can be manually set from 0.00000 to 999.99990 seconds. Note that this delay is separate from the Delay Action of the SDM cycle. The Delay Action is discussed next.

Source, delay, and measure actions

The SDM cycle of the SourceMeter consists of three actions: Source, Delay, and Measure:

SOURCE Action — Any programmed output voltage or current level changes are performed.

DELAY Action — This programmable delay is used to allow the source to settle before a measurement is performed. It can be manually set from 0.00000 to 9999.99900 seconds, or Auto Delay can be enabled. With Auto Delay enabled, the SourceMeter automatically selects a nominal delay period based on the selected function and range.

NOTE In the `:SYSTem:RCMode MULTiple` mode, the soak time programmed with `:SOURce[1]:SOAK` takes the place of the delay time only during the first SDM cycle after the initial sweep trigger. See [Section 18](#).

MEASURE Action — During this phase of the SDM cycle, the measurement process takes place. If the repeat filter is enabled, as shown in [Figure 11-4](#), the instrument samples the specified number of reading conversions to yield a single filtered reading (measurement). If using the moving filter or if the filter is disabled, only a single reading conversion will yield a reading.

Figure 11-4
Measure action

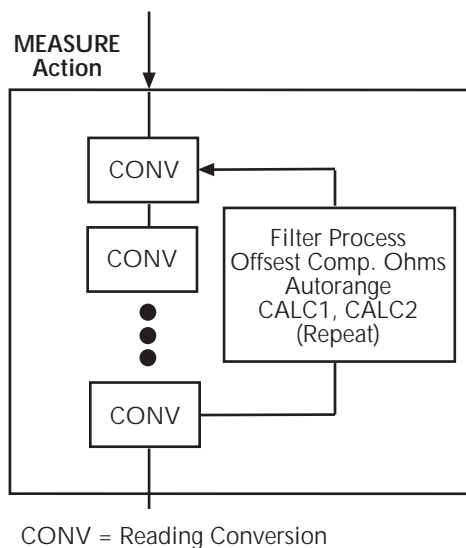

Counters

Programmable counters are used to repeat operations within the trigger model layers. For example, if performing a 10-point sweep, the trigger counter would be set to 10

(TRIGger:COUNT 10). Operation will stay in the Trigger Layer until the 10 source-delay-measure points of the sweep are performed.

If you wanted to repeat the sweep three times, the arm counter would be set to three (ARM:COUNT 3). Three 10-point sweeps can then be performed for a total of 30 source-delay-measure actions.

The maximum buffer size for the SourceMeter is 2500 readings. The product of the finite values of the two counters cannot exceed 2500. For example, if you set an arm count of two, the maximum trigger count will be 1250 ($2500 / 2 = 1250$). However, you can set the arm count to infinite (INF). With an infinite arm count, the maximum trigger count is 2500.

NOTE *With front panel operation only, when a sweep is configured, the trigger model settings will not change until the sweep is started. After the sweep is finished, the trigger model will reset to the previous settings.*

Output triggers

The SourceMeter can be programmed to output a trigger (via rear panel Trigger Link connector) after various trigger model operations. An output trigger is used to trigger another instrument to perform an operation. The default is no output triggers. See “[Trigger link](#)” later in this section for more information.

Trigger layer output triggers — The SourceMeter can be programmed to output a trigger after each action of the SDM cycle (Source, Delay and Measure). Output triggers are controlled with the TRIGger:OUTPut command.

For example, to output a trigger after the Measure Action, the following command must be sent:

```
TRIGger:OUTPut SENSE
```

The above command disables output triggers for the Source and Delay Actions since their parameter names (SOURce and DELay) are not included in the parameter list.

When used with a scanner, an output trigger after each measurement can signal the scanner to select the next channel in the scan.

Arm layer output trigger — As shown in [Figure 11-3](#), the SourceMeter can be programmed to output a trigger when operation leaves the Arm Layer and enters the Trigger Layer, or after operation leaves the Trigger Layer and enters back into the Arm Layer. This output trigger is typically sent to another instrument to signal the end of a scan or sweep. The ARM:OUTPut command is used to control these output triggers. The TENTER parameter enables the trigger on entering the Trigger Layer, the TEXit parameter enables the trigger on exiting the Trigger Layer, and the NONE parameter disables both output triggers.

GPIB defaults

The GPIB defaults are listed as follows. They are also denoted in [Figure 11-3](#) by the “+” symbol.

- Arm-In Event = Immediate
- Trigger-In Source = Immediate
- Arm Count = 1
- Trigger Count = 1
- Trigger Delay = 0.0 sec
- Delay Action = 0.001 sec
- Enabled event detector = Source Event Detector (Delay and Measure detection disabled)
- Enabled output triggers = None
- Event detection bypasses = Acceptor (both layers)

With output turned ON (OUTPut ON), the SourceMeter will perform one SDM cycle when the INITiate command is sent. After the measurement, the SourceMeter returns to the idle state.

Remote trigger commands

Table 11-1 summarizes remote trigger commands. These commands are covered in more detail in Section 18 except for *TRG, a common command covered in Section 16.

Table 11-1

Remote trigger commands

Command	Description
:INITiate	Take SourceMeter out of idle state.
:ABORT	Abort operation, return to idle.
:ARM:COUNT <n>	Set arm count (n = count).
:ARM:SOURce <name>	Specify arm control source. Name = IMMEDIATE, TLINK, TIMER, MANUAL, BUS, NSTest, PSTest, or BSTest.
:ARM:TIMer <n>	Set arm layer timer interval (n = interval).
:ARM:DIRection <name>	Control arm bypass. (Name = SOURce or ACceptor).
:ARM:ILINe <NRf>	Select arm layer input line. (NRf = input line #).
:ARM:OLINe <NRf>	Select arm layer output line (NRf = output line #).
:ARM:OUTPut <event list>	Select arm layer output events. (Event list = TENTer, TEXit, or NONE).
:TRIGger:CLEar	Clear any pending input triggers immediately.
:TRIGger:COUNT <n>	Set trigger count (n = count).
:TRIGger:DELay <n>	Set trigger delay (n = delay). ¹
:TRIGger:SOURce <name>	Specify trigger control source. Name = IMMEDIATE or TLINK.
:TRIGger:DIRection <name>	Control trigger bypass. (Name = SOURce or ACceptor).
:TRIGger:ILINe <NRf>	Select trigger layer input line (NRf = input line).
:TRIGger:OLINe <NRf>	Select trigger layer output line (NRf = output line).
:TRIGger:INPut <event list>	Select trigger input layer events. (Event list = SOURce, DELay, SENSE, or NONE).
:TRIGger:OUTPut <event list>	Select trigger layer output events. (Event list = SOURce, DELay, SENSE, or NONE).
*TRG	Trigger SourceMeter (if BUS source selected).

1. Invalid (ignored) for the Model 2430 Pulse Mode.

Trigger link

Input and output triggers are received and sent via the rear panel TRIGGER LINK connector. The trigger link has four lines. At the factory, line #2 is selected for output triggers, and line #1 is selected for input triggers. These input/output line assignments can be changed from the CONFIGURE TRIGGER menu. (See “[Configuring triggering](#),” page 11-7.) The connector pinout is shown in [Figure 11-5](#).

Input trigger requirements

An input trigger is used to satisfy event detection for a trigger model layer that is configured for the TRIGGER LINK event. (See “[Trigger models](#),” page 11-20.) The input requires a falling-edge, TTL compatible pulse with the specifications shown in [Figure 11-6](#).

Figure 11-5
Rear panel pinout

Rear Panel Pinout	Pin Number	Description
	1	Trigger Link 1
	2	Trigger Link 2
	3	Trigger Link 3
	4	Trigger Link 4
	5	Not connected
	6	Not connected
	7	Ground
	8	Ground

Figure 11-6
Trigger link input pulse specifications



Output trigger specifications

The SourceMeter can be programmed to output a trigger after various trigger model actions. (See “[Trigger models](#),” [page 11-20](#).) The output trigger provides a TTL-compatible output pulse that can be used to trigger other instruments. The specifications for this trigger pulse are shown in [Figure 11-7](#).

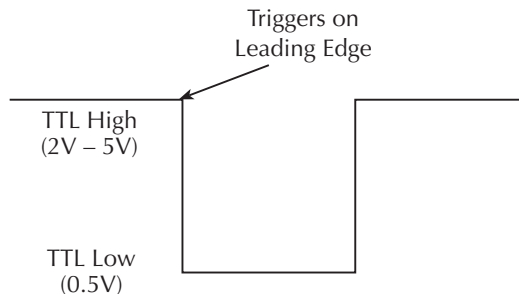
Figure 11-7

Trigger link output pulse specifications

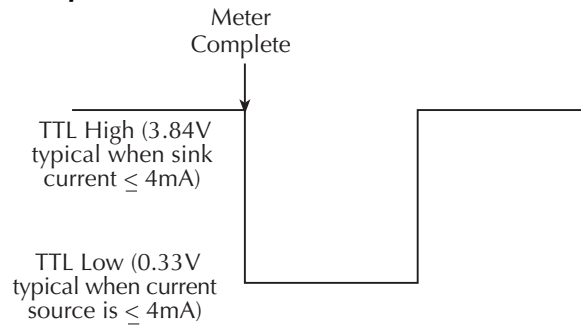

Pulse Mode triggering (Model 2430)

Triggering for the Model 2430 is similar to triggering for the DC Mode. However, in order to accomplish fast pulse output, triggering is simplified for the Pulse Mode. The following information covers the triggering differences between the DC Mode and Pulse Mode.

Trigger models

The front panel trigger model for the Pulse Mode is shown in [Figure 11-8](#), while the trigger model for remote operation is shown in [Figure 11-9](#). These trigger models are simplified versions of their DC Mode counterparts ([Figure 11-1](#) and [Figure 11-3](#)).

NOTE *The following trigger model information assumes that you are already familiar with the basic DC Mode trigger model operation presented earlier in this section.*

Figure 11-8
2430 Pulse Mode trigger model (front panel operation)

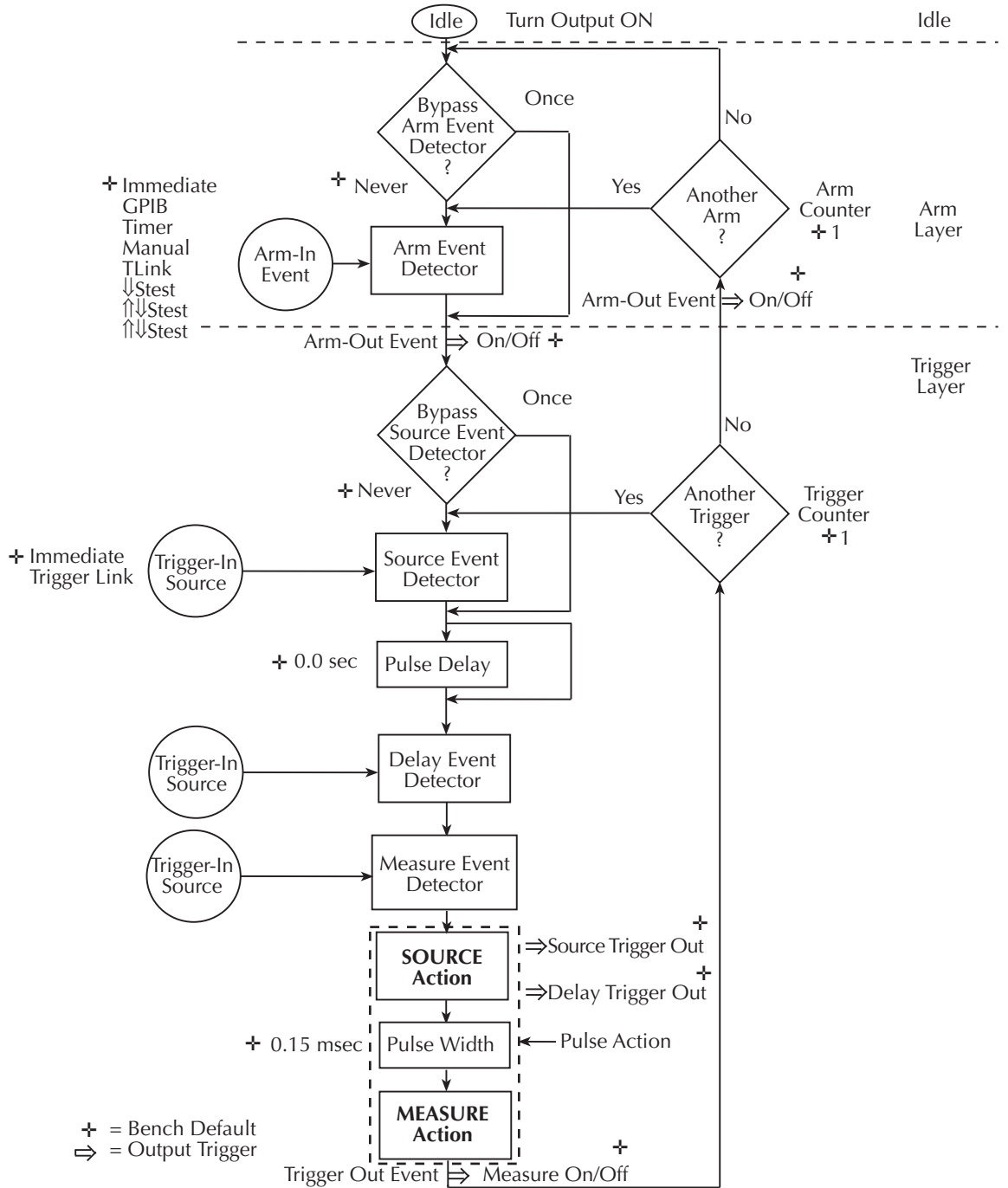
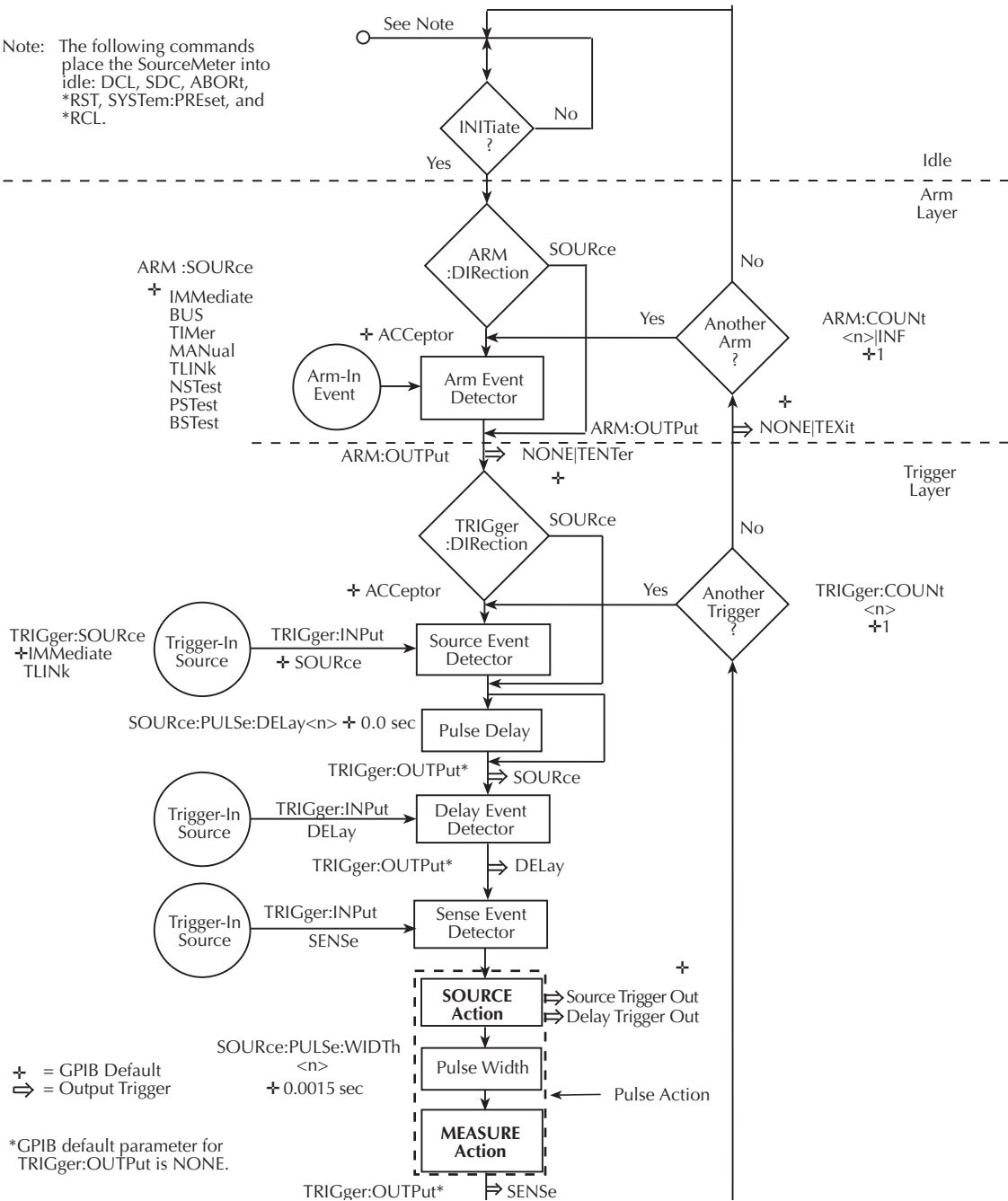

Figure 11-9
2430 Pulse Mode trigger model (remote operation)

Note: The following commands place the SourceMeter into idle: DCL, SDC, ABORT, *RST, SYSTem:PREset, and *RCL.



Idle

As with DC Mode front panel operation, the SourceMeter is taken out of idle by pressing the ON/OFF OUTPUT key.

For DC Mode remote operation, the output must be on and then an initiate command must be sent to take the instrument out of idle. For Pulse Mode remote operation, the output is turned on and initiation is satisfied when :INITiate, :READ? or :OUTPut[1][:STATe] ON is sent.

Pulse delay

Instead of a Trigger Delay used in the DC Mode, the Pulse Mode uses a Pulse Delay. This delay is set by the user and is part of the pulse off-time.

After event detection, operation proceeds to the Pulse Delay. However, for the initial pass through the trigger model, the Pulse Delay is bypassed as shown in [Figure 11-8](#). This initial loop around the delay allows the pulse to be sourced as soon as the output is turned on.

Source action

The source action turns on the output to source the pulse.

Pulse width

The pulse-width is the time duration that the output is on. Depending on how the SourceMeter is configured, the pulse width can be as short as 0.25msec or as long as 5msec. In general, the pulse width is made up of a delay and the signal measurement. See [Section 5](#) for details on pulse width timing.

Measure action

With Auto Zero enabled, a reading consists of three measurements; signal, reference and zero. These three measurements are then used to calculate an accurate pulse reading. The signal is measured first while the output is on. After the signal measurement is completed, the output turns off, and the reference and zero measurements are performed.

With Auto Zero disabled, the reference and zero measurements are not performed. This allows a faster pulse train by shortening the output off-time. Note however, that zero drift will eventually result in inaccurate readings.

For the DC Mode, the filtering process is part of the Measure Action. In the Pulse Mode, filtering is not used.

Output triggers

All three output triggers are available in the trigger layer for the Pulse Mode. If enabled, the output triggers occur where indicated in the trigger model.

Invalid trigger settings

Front panel operation

For front panel operation, most trigger settings are done from the “CONFIGURE TRIGGER” menu which is accessed by pressing CONFIG and then TRIG. For Pulse Mode operation, the following settings for the “TRIG LAYER” are ignored.

DELAY — Trigger delay is not used. Therefore, the trigger DELAY setting is ignored.

TRIGGER OUT EVENTS — For the DC Mode, source delay is set from the source configuration menu, which is accessed by pressing CONFIG and then SOURCE V or I. When the Pulse Mode is selected, the source delay menu items (DELAY and AUTO DELAY) are replaced by the pulse DELAY and PULSE WIDTH menu items.

Remote operation

The following commands are not valid in the Pulse Mode and are therefore ignored:

:TRIGger:DELay — Trigger delay is not used in the Pulse Mode.

:SOURce:DELay and **:SOURce:DELay:AUTO** — Source delay is not used in the Pulse Mode.

12

Limit Testing

- **Types of limits** — Discusses the three types of limits: compliance, coarse limits, and fine limits. Also summarizes the two operating modes: grading and sorting.
- **Operation overview** — Covers binning control and pass/fail condition for the grading and sorting modes.
- **Binning systems** — Details the handler interface, as well as single-element and multiple-element binning and digital output clear pattern that occurs after a binning operation.

NOTE The Model 2401 does not use the digital output lines of the Digital I/O port. The Model 2401 does not have a handler interface and therefore cannot be used with a component handler to perform binning operations.

- **Configuring and performing limit tests** — Describes how to configure the SourceMeter for limit testing and summarizes a typical test procedure.
- **Remote limit testing** — Summarizes limit commands and provides a basic programming example.

Types of limits

As shown in [Figure 12-1](#), there are 11 limit tests that can be performed on a DUT. These limits include:

- Limit 1: compliance test
- Limit 2: course limits
- Limits 3, 5-12: fine limits

NOTE *Limit 4 is reserved for the contact check option. See [Appendix F](#) for details.*

A test is only performed if it is enabled. Thus, you can perform one, two, or all 11 tests. The tests are always performed in the order shown in the drawing.

Figure 12-1
Limit tests

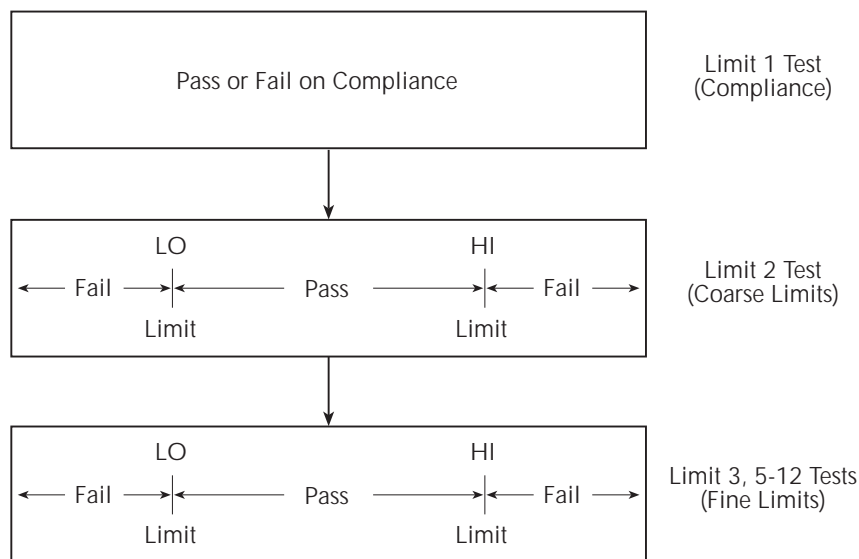

Pass/fail information

Pass/fail information for limit tests can be obtained as follows:

- A PASS or FAIL indication on the front panel display.
- By programming the unit to output specific pass/fail bit patterns on the Digital I/O port, which can be used to control other equipment such as a device handler

for binning operations. See [“Binning systems,” page 12-10](#), and [Section 13, “Digital I/O port,”](#) for more information.

NOTE *The Model 2401 does not have a handler interface and therefore cannot be used with a component handler to perform binning operations.*

- With the `:CALCulate2:LIMit<n>:FAIL?` query via remote, where `<n>` is the limit test number ([Section 18, “CALCulate2”](#)).
- By reading various status bits ([Section 15, “Status Structure,”](#) and [Section 18, “FORMat subsystem”](#)).
- By noting a “P” or “F” preceding buffer location numbers ([Section 9, “Recalling readings”](#)).

Data flow

All limit tests are part of the CALC2 data block. See [Appendix C](#) for an overview on how limit testing fits into the overall data flow through the SourceMeter.

Limit 1 test (compliance)

This hardware (H/W) test checks the compliance state of the SourceMeter. It uses the programmed compliance as the test limit. At or above the programmed limit, the instrument is in compliance. Below the limit, the instrument is not in compliance.

Limit 2, limit 3, and limit 5-12 tests

These software (S/W) tests are used to determine if a DUT is within specified high and low limits. Typically, the Limit 2 test is used to test for coarse tolerance limits, and the Limit 3 and Limit 5-12 tests are used for fine tolerance limits.

Limit 4

This hardware test is only available for instruments equipped with the optional contact check feature. See / for details about the contact check option. Distinct Digital I/O bit patterns can be set for each limit and each high/low pass or fail condition.

Limit test modes

There are two modes of operation for limit tests: grading and sorting. For Limit 1 test (compliance), operation is similar for both limit test modes. If Limit 1 test fails, the “FAIL” message is displayed and the testing process for that DUT (or DUT element) is terminated. A pass condition allows the testing process to proceed to the next enabled limit test.

With the grading mode selected, each enable software test (Limit 2, 3, 5-12) is performed until a failure occurs. When a test fails, the FAIL message is displayed and the testing process for that DUT (or DUT element) is terminated.

With the sorting mode selected, each enabled software test (Limit 2, 3, 5-12) is performed until a test passes. When a test passes, the PASS message is displayed and the testing process for that DUT is terminated.

Binning

Even though no additional equipment is required to perform limit tests on the DUT, a component handler can be interfaced to the SourceMeter Digital I/O port to perform binning operations. After the testing process, the DUT will be placed in an assigned bin.

NOTE The Model 2401 does not have a handler interface. Therefore it cannot be used with a component handler to perform binning operations.

For the grading mode, the binning system can be further automated by adding a scanner. With the use of a scanner, the tests can be repeated (cycled) to test individual elements of a single package (i.e., resistor network). See [“Binning systems,” page 12-10](#), for more information on using component handlers and scanners to perform binning operations.

Operation overview

Grading mode

Grading mode limits operation is detailed by the flowchart in [Figure 12-2](#). A test is only performed if it is enabled. If disabled, operation proceeds to the next test. The following assumes the first three limit tests are enabled and the digital output of the SourceMeter is connected to a component handler for DUT binning. (See [“Binning systems,” page 12-10](#).) If a handler is not used, ignore digital input/output (handler interface) actions.

NOTE The Model 2401 does not have a handler interface. Therefore it cannot be used with a component handler to perform binning operations.

With the limit tests properly configured, turn the SourceMeter output on and press the LIMIT key. In this example, the testing process will start when the component handler sends the start-of-test (SOT) strobe pulse to the SourceMeter. Note that if a handler is not used, testing will start when LIMIT is pressed. Pressing LIMIT a second time terminates the testing process. As shown in the flowchart, limit tests are performed after a measurement conversion.

Figure 12-2
Grading mode limit testing

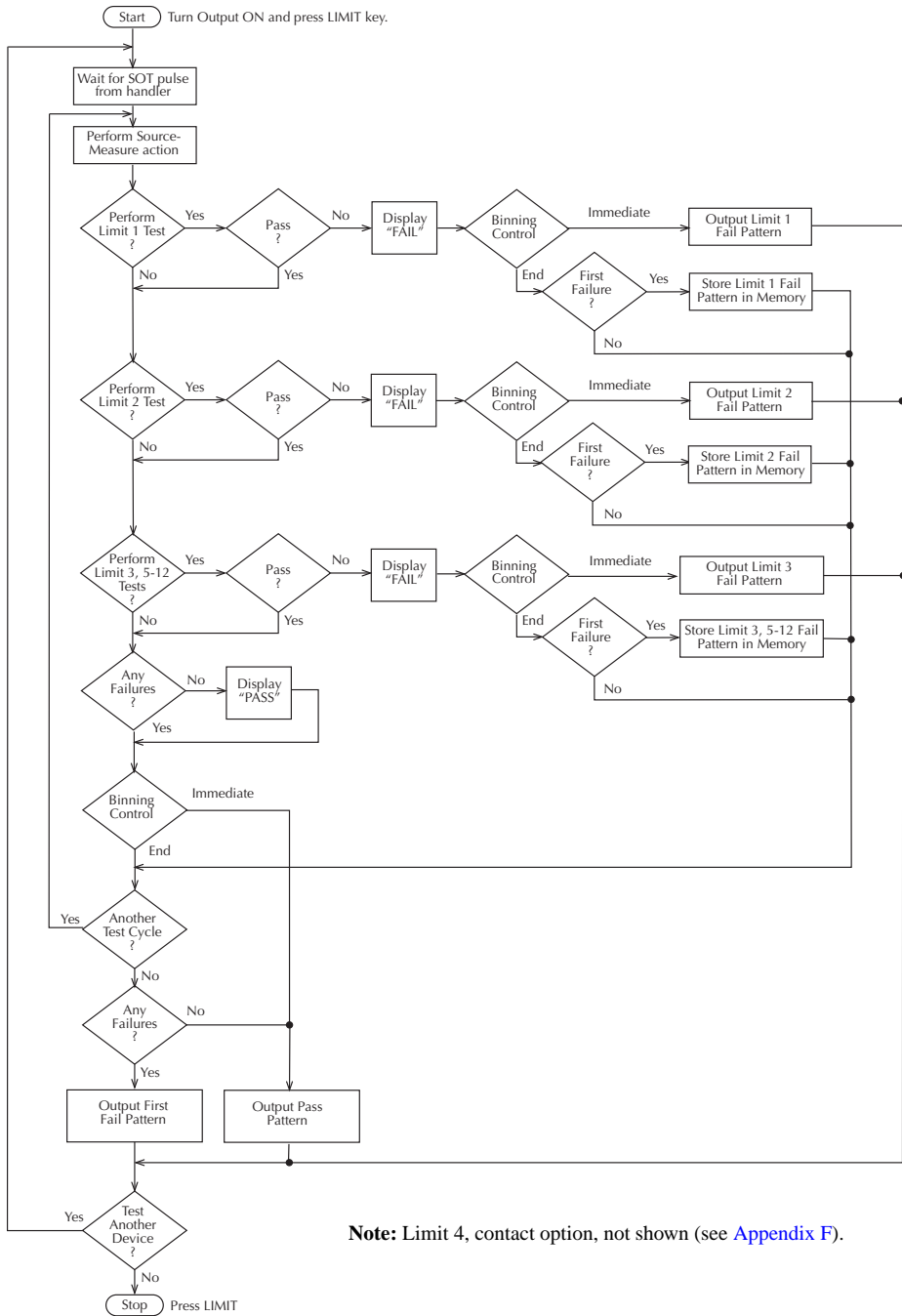

Note: Limit 4, contact option, not shown (see [Appendix F](#)).

NOTE If using the contact check option, see flowchart, [Figure F-4](#), in Appendix F.

Binning control

The binning control selection determines when the testing process stops and the appropriate binning operation occurs. The results are communicated through the Digital I/O port based on limit test data. (See “[Binning systems](#),” page 12-10.) There are two types of binning control for the grading mode: immediate and end.

NOTE Binning affects contact check tests. See [Appendix F](#) for details.

Immediate binning — Use immediate binning when you want to stop all testing after the first failure occurs. Any pending tests will be cancelled, and the DUT will be placed in the bin assigned to that test failure. If no failures occur, all enabled tests will be performed, and the DUT will be placed in the assigned pass bin. This process is demonstrated in

[Figure 12-3](#).

Figure 12-3

Immediate binning

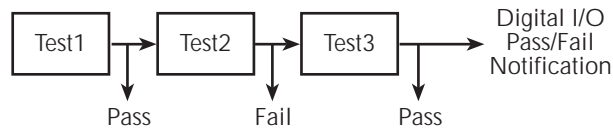

End binning — End binning allows a sweep to finish before performing the binning operation. In the event of a failure, the first test failure determines the bin assignment. (See

[Figure 12-4](#).)

Figure 12-4

End binning

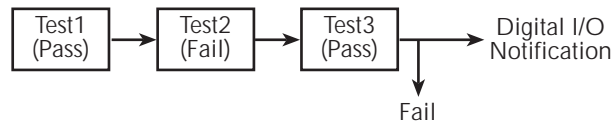

Pass condition

For this discussion, assume that all grading mode limit tests pass. After the three limit tests pass, the “PASS” message is displayed, and operation drops down to

the Binning Control decision block. (Note that the pass condition can also be determined with the :CALC2:LIM<n>FAIL? query via remote.)

Immediate binning — For immediate binning, the testing process stops. The SourceMeter outputs the pass pattern via the Digital I/O port to the component handler to perform the binning operation.

End binning — For end binning, operation drops down to Another Test Cycle? decision block. If programmed to perform additional tests (i.e., sweep) on the DUT package, operation loops back up to perform the next source-measure action. After all programmed test cycles are successfully completed, the SourceMeter outputs the pass pattern to the component handler to perform the binning operation.

If configured to test another DUT package, the operation loops back to the top of the flowchart and waits for the start-of-test (SOT) pulse from the component handler.

Fail condition

When a failure occurs, the FAIL message is displayed (and also can be read via remote with :CALC2:LIM<n>FAIL?), and operation proceeds to the Binning Control decision block.

Immediate binning — For immediate binning, the testing process is terminated when a failure occurs, and the fail pattern for that particular failure is sent to the component handler to perform the binning operation. Triggering is maintained for other instruments or components in the test system.

End binning — For end binning, the fail pattern for the first failure is stored in memory and operation proceeds to Another Test Cycle? decision block. If programmed to perform additional tests (i.e., sweep) on the DUT package, operation loops back up to perform the next source-measure action.

After all programmed test cycles are completed, the SourceMeter outputs the fail pattern stored in memory on the Digital I/O port. This reflects the first failure that occurred in the testing process for the device package. The component handler places the DUT in the appropriate bin.

If configured to test another DUT package, operation loops back to the top of the flowchart and waits for the start-of-test (SOT) pulse from the component handler.

Sorting mode

Sorting mode limits operation is detailed by the flowchart in [Figure 12-5](#). A test is only performed if it is enabled. If disabled, operation proceeds to the next test. The following assumes the digital output of the SourceMeter is connected to a component handler for DUT binning. (See [“Binning systems,” page 12-10](#).)

NOTE The Model 2401 does not have a handler interface. Therefore it cannot be used with a component handler to perform binning operations.

NOTE If using the contact check option, see flowchart, [Figure F-4](#), in Appendix F.

Binning

For the sorting mode, only immediate binning can be performed. After the testing process is finished (FAIL or PASS displayed), the appropriate output bit pattern will be sent to the component handler which will place the DUT in the assigned bin. (The pass/fail condition can also be queried via remote with :CALC2:LIM<n>:FAIL?.)

Figure 12-5
Sorting mode limit testing

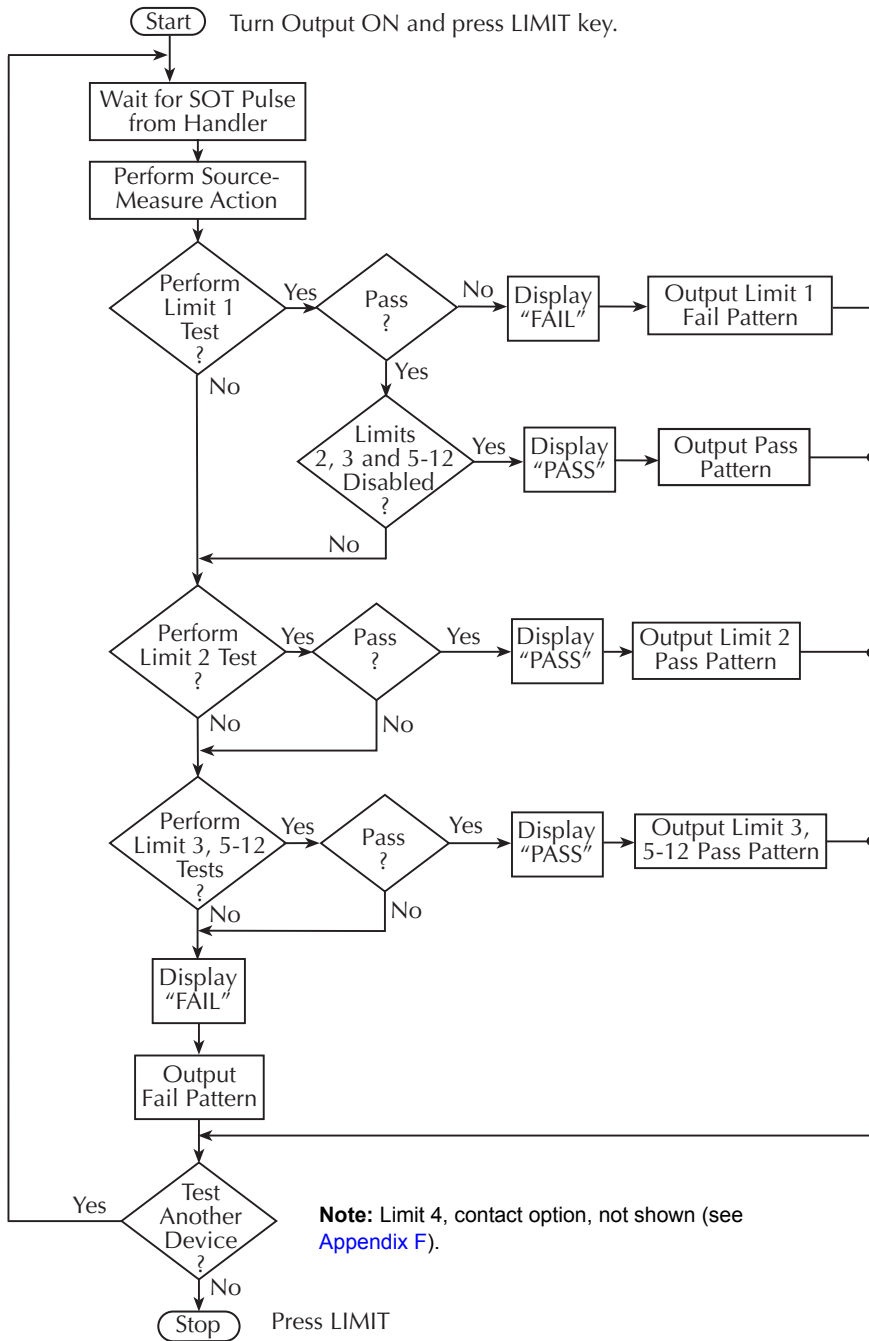

Binning systems

NOTE The Model 2401 does not have handler interface. Therefore it cannot be used with a component handler to perform binning operations.

The SourceMeter can be used with a component handler to perform binning operations on DUT packages. With this system, you can test single-element devices (i.e., resistor). Adding a scanner to the system allows binning operations on multiple-element DUT packages. See [Multiple-element device binning](#).

Handler interface

The SourceMeter is interfaced to a handler via the Digital I/O port as shown in [Figure 12-6](#). The I/O port has four lines for output signals (Out 1 through Out 4) as well as input lines for start-of-test (SOT) and /OE (output enable) signals. The output lines are used to send the limit test pass/fail signal(s) to the handler to perform the binning operation.

Figure 12-6
Handler interface connections

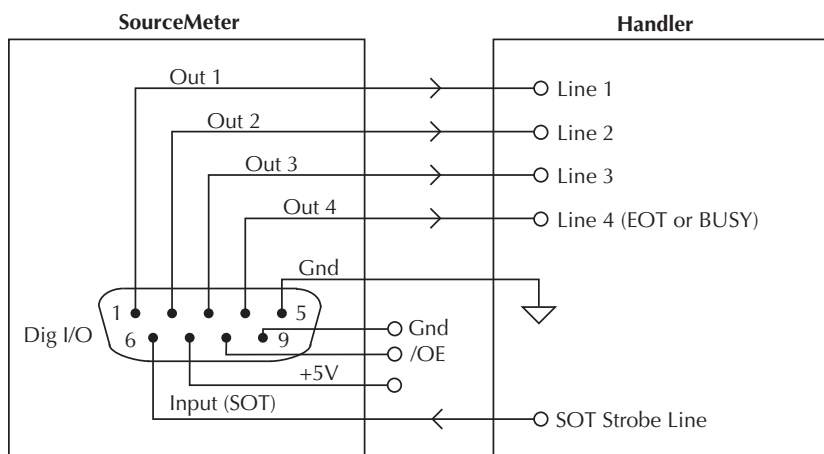

Digital I/O connector

These digital I/O lines are available at the DB-9 Digital I/O connector on the rear panel of the SourceMeter. A custom cable using a standard female DB-9 connector is required for connection to the SourceMeter. See [Section 13, "Digital I/O port,"](#) for more information.

Digital output lines

The four output lines output a specific bit pattern based on the pass/fail results of the various limit tests. (See “Types of limits,” page 12-2.) In the 3-bit output mode, Line 4 can also be used either as an end-of-test (EOT) or BUSY signal depending on the END OF TEST mode. (See “Configuring limit tests,” page 12-16.)

EOT or Busy Line

In the 3-bit mode, line 4 can be used to flag the handler when the digital I/O lines may be read. Depending on the type of handler present, either BUSY or end-of-test (EOT) may be used. These signals are defined as follows:

BUSY — The BUSY signal indicates the time from which the start-of-test (SOT) signal is received until all measurements, limit testing, and digital I/O operations have been completed. When /BUSY is selected, line 4 goes LO during this time period.

NOTE The arm source must be set to SOT in order to use BUSY.

EOT — The end-of-test strobe signals to the handler that the digital I/O lines may be read. This pulse occurs approximately 10us after the SourceMeter(c) has updated the digital I/O lines and ends approximately 10us before the digital I/O lines actually clear. The EOT pulse width is specified by the digital auto clear delay. EOT is HI when the digital I/O is updated. /EOT goes LO after the digital I/O lines are updated.

NOTE Digital auto-clear must be enabled in order to use EOT.

SOT line

The input line (SOT) of the Digital I/O is used to control the start of the testing process. For remote operation with ↓STEST selected as the arm event of the trigger model, the testing process will start when the SOT line is pulsed low. When ↑STEST is the selected arm event, the testing process will start when the SOT line is pulsed high. When ↑↓STEST is selected, testing will start when SOT is pulsed either high or low. For front panel operation with the IMMEDIATE arm event selected, the testing process will start as soon as the LIMIT key is pressed (assuming the output is ON). See Section 11, “Triggering,” for details on trigger model configuration.

When using the SOT line, the handler will not pulse the line while it is in a not ready condition. When the handler is ready (DUT properly positioned in the handler), it pulses the SOT line low or high to start the test.

/OE line

The /OE (output enable) line of the Digital I/O can be used if the component handler is equipped with a switch. With proper use, power is removed from the DUT

when the lid of the handler is opened to eliminate a possible shock hazard. See [Section 13, “Digital I/O port”](#) and [“Output enable line,”](#) for operation details on the output enable line.

Handler types

The SourceMeter can be used with either of the two basic types of handlers. When used with a Category Pulse Handler, the SourceMeter pulses one of the four handler lines. The handler then places the DUT into the bin assigned to the pulsed line.

When used with a Category Register Handler, the SourceMeter outputs a bit pattern to three handler lines. After the SourceMeter sends the end-of-test (EOT) strobe pulse to the fourth handler line, the handler places the DUT into the bin assigned to that bit pattern.

Category pulse component handler

When using this type of handler, the SourceMeter pulses one of the four handler lines when a pass or fail condition occurs. The handler then places the DUT in the bin assigned to that pulsed line. When interfacing to this type of handler, a maximum of four component handler bins are supported.

If the handler requires low-going pulses, then the four digital output lines of the Source-Meter must be initially set to high. This initial HI, HI, HI, HI clear pattern on the output lines represents a no action condition for the handler since it is waiting for one of the lines to go low. A line goes low when the defined fail or pass pattern sets it low. For example, if you want a particular test failure to pulse line #4 of the handler, the defined fail pattern has to be HI, HI, HI, LO. When the failure occurs, line #4 will be pulled low, and the DUT will be placed in the bin assigned to that pulsed line.

If the handler requires a high-going pulse, the four digital output lines of the SourceMeter must initially be set low. The LO, LO, LO, LO clear pattern represents the no action condition for the handler. When one of those lines are pulled high by a defined pass or fail bit pattern (i.e., LO, LO, LO, HI), the DUT will be placed in the bit assigned to that pulsed line.

Category register component handler

When using this type of handler, the SourceMeter sends a bit pattern to three handler lines when a pass or fail condition occurs. This bit pattern determines the bin assignment for the DUT. With the pass/fail pattern on the output, line #4 is then pulsed. This end-of-test (EOT) pulse latches the bit pattern into the register of the handler, which places the DUT in the assigned bin. When interfacing to this type of handler, a maximum of eight component handler bins are supported.

If the handler requires a high-going or low-going EOT pulse, program SourceMeter for 3-bit operation and appropriate EOT mode.

NOTE The EOT and 3-bit modes are configured from the CONFIG LIMITS MENU. See [“Configuring limit tests,” page 12-16](#).

Basic binning systems

Two basic binning systems are shown in [Figure 12-7](#) and [Figure 12-8](#). Both systems require a handler to physically place the device packages in the appropriate bins. The handler is controlled by the SourceMeter via the Digital I/O port.

Single-element device binning

[Figure 12-7](#) shows a basic binning system for single-element devices (i.e., resistors). After all programmed testing on the DUT is completed, the pass/fail digital output information is sent to the component handler, which then places the DUT in the appropriate bin. The component handler selects the next DUT, and the testing process is repeated.

Figure 12-7
Binning system single-element devices

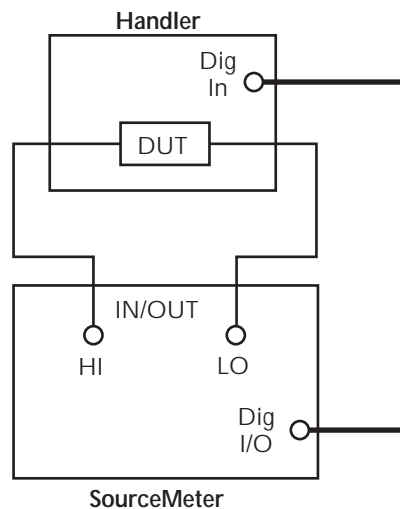

Multiple-element device binning

[Figure 12-8](#) shows a basic binning system to test three-element resistor networks. Note that this system requires a scanner card that is installed in a switching main-

frame. Scanner card switching is controlled through the Trigger Link. End binning control is required for this test system, therefore, the grading mode must be used.

Figure 12-8
Binning system multiple-element devices

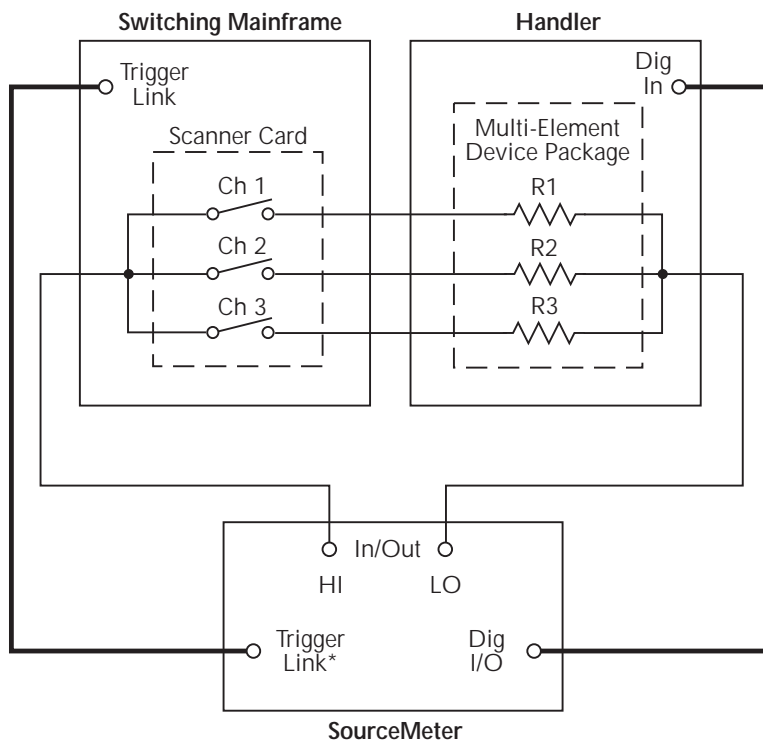

*Trigger layer configured to output trigger pulse after each measurement.

Digital output clear pattern

After every binning operation, the digital output needs to be reset to a clear pattern, which serves as a no action condition for the component handler.

The SourceMeter can be programmed to automatically clear the digital output after the pass or fail pattern is sent. With auto-clear enabled, you can specify the required pulse width (delay) for the pass or fail pattern. (The default auto-clear pulse width is 10 μ s.) When not using auto-clear, you must return the digital output to its clear pattern from the DIGOUT AUTO CLEAR option of the CONFIG LIMIT menu. This option also sets the pass/fail pattern and pulse width.

Enabling auto-clear

To enable auto-clear:

1. Press CONFIG then LIMIT.
2. Select DIGOUT, then press ENTER.
3. Choose AUTO CLEAR, then press ENTER.
4. Select ENABLE, then press ENTER.
5. At the prompts, set the auto-clear pulse width (0s to 60s) and clear bit pattern (0 to 15, 4-bit; 0 to 7, 3-bit size). Use EXIT to return to normal display.

Auto-clear timing

The following timing diagram example (Figure 12-9) and discussion explain the relationship between the digital output lines for auto-clear.

Figure 12-9

Digital output auto-clear timing example

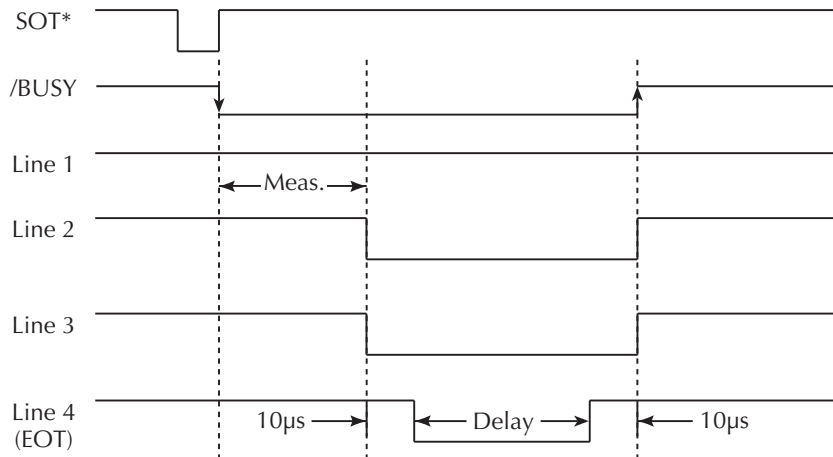

* With the SOT line being pulsed low (as shown), ↓ STEST must be the selected event for the trigger model. If the SOT line is instead pulsed high by the handler, ↑ STEST must be the selected arm event. For high or low pulses, select ↑↓STEST.

Initially, the four digital output lines are cleared (in this case, they are all set high). Limit tests start when the start-of-test (SOT) pulse is received from the component handler. When the testing process is finished, the pass or fail pattern is applied to the digital output. As shown in the diagram, lines 2, 3, and 4 go low while line 1 remains high.

The pulse width (delay) of the pass/fail pattern can be set from 0 to 60sec (10µsec resolution) as required by the component handler. Note that the delay specifies the pulse width of line 4. The pulse width of lines 1, 2, and 3 is actually 20µsec longer. Line 4 is skewed because it is used as the end-of-test (EOT) strobe by category register component handlers. Lines 1, 2, and 3 establish the bit pattern and then 10µsec later the SOT strobe tells the handler to read the bit pattern and perform the binning operation. This 10µsec offset is used to make sure the correct bit pattern is read by the handler.

After the pass/fail is read by the handler, the digital output returns to the clear pattern with auto-clear enabled.

Configuring and performing limit tests

Configuring limit tests

NOTE The Model 2401 does not use the digital output lines of the Digital I/O port. Therefore it cannot be used with a handler to perform binning operations. If using a Model 2401 for limit testing, ignore all actions and information that pertain to binning.

Press CONFIG and then LIMIT to display the CONFIG LIMITS MENU. The limits configuration menu is structured shown below and in [Figure 12-10](#). Note that bullets indicate the primary items of the limit menu and dashes indicate the options of each menu or submenu item. Refer to [Section 1](#), “[Rules to navigate menus](#)” to configure the limit tests.

- **DIGOUT** — Use this menu item to control the following Digital I/O aspects:
 - **SIZE** — Use to select 3-BIT or 4-BIT Digital I/O bit size. In the 3-BIT mode, Digital I/O line 4 becomes the EOT, /EOT, BUSY, or /BUSY signal depending on the selected END OF TEST mode. In the 4-BIT mode, Digital I/O line 4 is controlled manually if the END OF TEST mode is set to EOT.
 - **MODE** — Use to select GRADING or SORTING mode:
In GRADING mode, a reading passes if it is within all of the HI/LO limit tolerances enabled, assuming that it has passed the Contact Check (contact check option only) and Compliance tests first. The Digital I/O will be driven with the first pattern of the first Contact Check, Compliance, HI, or LO failure. Otherwise, the pass pattern will be output. In GRADING mode, you will also choose bin control modes. With IMMEDIATE, the testing process will stop after the first failure and place the fail pattern on the digital output. If none of the limit tests fail, the pass pattern will be placed on the output, and the testing process will stop. With END, the testing process will continue until the programmed sweep is completed, regardless of how many failures occur. This

allows multi-element devices (i.e., resistor networks) to be tested. After testing is finished, the bit pattern for the first failure is placed on the output. If all tests pass, the pass pattern will instead be placed on the output.

In SORTING mode, a reading will fail if it fails the optional Contact Check Test, the Compliance Test, or is not within any of the Digital I/O Bands. If the tests pass and only Limit 1 or 4 (optional contact check test) is enabled, the associated pass pattern will be output. Otherwise, the first limit test band that passes will output its lower limit pattern (upper limit patterns will be ignored). If Limit 1 or 4 fails, their failure patterns will be output. If no Limit 2, 3, or 5-12 passes, their failure pattern will be output. When SORTING is selected, the Digital I/O bit pattern can also be set (0 to 7, 3-bit; 0 to 15, 4-bit).

- **AUTO CLEAR** — Use this menu item to ENABLE or DISABLE auto-clear for the digital output. After enabling auto-clear, you will be prompted to set the pass/fail pattern pulse width (delay; 0 to 60.00000sec). You will then be prompted to set the digital output clear pattern (0 to 7, 3-bit; 0 to 15, 4-bit).
- **H/W LIMITS** — Use this menu item to control and set the fail mode for the Limit 1 (Compliance) test:
 - **CONTROL** — Use to ENABLE or DISABLE the test.
 - **FAIL MODE** — Use to select the fail mode for Limit 1 test. With IN selected, the test will fail when the SourceMeter is in compliance. With OUT selected, the test will fail when not in compliance. Also use to specify the digital output bit pattern for Limit #1 IN or OUT test failure (0 to 7, 3-bit; 0 to 15, 4-bit).

NOTE If the contact check option is installed, the H/W LIMITS selection will also set options for the Contact Check Test (Limit 4). See [Appendix F](#) for contact check details.

- **S/W LIMITS** — Use this menu item to control, set limits for, and define output bit patterns for LIM2, LIM3, and LIM5 through LIM12 tests:
 - **CONTROL** — Use to ENABLE or DISABLE the test.
 - **LOLIM** — Use to set the low limit and, for the grading mode, specify the fail bit pattern (0-7; 3-bit; 0 to 15; 4-bit).
 - **HILIM** — Use to set the high limit and, for the grading mode, specify the fail bit pattern (0 to 7; 3-bit; 0 to 15; 4-bit).
- **PASS** — Use this menu item to dictate actions upon a PASS condition:
 - **DIG I/O PATTERN** — Use this option item to define the digital output bit pattern (0 to 7, 3-bit; 0 to 15, 4-bit). For the grading mode, it is the pass pattern for the all tests pass condition. For the sorting mode, it is the pass pattern for Limit 1 (compliance) when all other software limit tests are disabled (0 to 7, 3-bit; 0 to 15, 4-bit).

- **SRC MEM LOC** — Use this option with a Source Memory Sweep to select the next memory location point in the sweep when the PASS condition occurs. If NEXT is selected, the next point in the sweep list will be selected. You can also branch to a different point in the sweep by specifying the memory LOCATION# (1 to 100).
- **EOT MODE** — Use this menu item to control the operation of Digital I/O line 4 to act as an end-of-test (EOT) or BUSY signal:
 - **BUSY** — Set Digital I/O line 4 HI while unit is busy. With BUSY selected, the unit behaves as if it is in 3-bit mode. Requires SOT as the arm source.
 - **/BUSY** — Set Digital I/O line 4 LO while unit is busy. With /BUSY selected, the unit behaves as if it is in 3-bit mode. Requires SOT as the arm source.
 - **EOT** — In 3-bit mode, automatically output a HI pulse on Digital I/O line 4 at end-of-test. In 4-bit mode, EOT is not automatically controlled. Requires digital auto-clear to be enabled.
 - **/EOT** — In 3-bit mode, automatically output a LO pulse on Digital I/O line 4 at end-of-test. In 4-bit mode, EOT is not automatically controlled. Requires digital auto-clear to be enabled.

Figure 12-10
Limits configuration menu tree

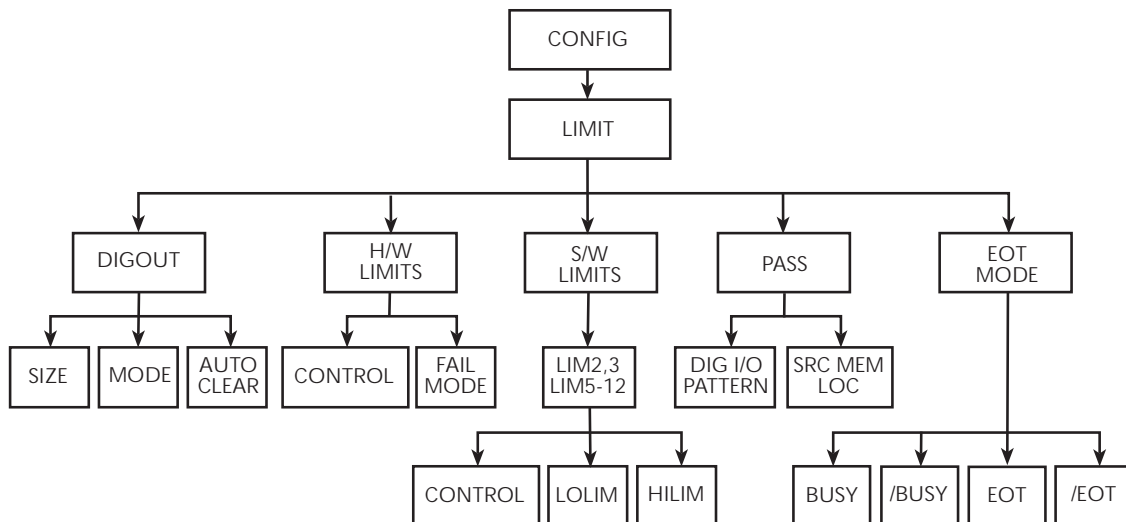

Performing front panel limit tests

Perform the basic steps below to run limit tests from the front panel. See [“Remote limit testing,” page 12-20](#), for remote commands and a programming example.

NOTE The Model 2401 does not use the digital output lines of the Digital I/O port. Therefore it cannot be used with a handler to perform binning operations. If using a Model 2401 for limit testing, ignore all actions and information that pertain to binning.

Step 1: Configure test system.

As previously explained, your test system could be as simple as connecting a DUT to the SourceMeter ([Section 2, “Connections”](#)) or could employ the use of a handler for binning operations. Adding a scanner to the test system allows you to test multi-element devices (such as resistor networks).

Step 2: Configure source-measure functions.

Configure the SourceMeter for the desired source-measure operations.

Step 3: Configure limit tests.

Select and configure the following limit tests parameters as explained in [“Configuring limit tests,” page 12-16](#):

Step 4: Turn output on.

Press the ON/OFF key to turn the output on (OUTPUT indicator turns on). The Source-Meter will output the programmed bias level.

Step 5: Start testing process.

To enable the limit tests, press the LIMIT key. If the /SOT line of the Digital I/O is being used by a handler, the testing process will not start until the handler sends a low-going pulse. Otherwise, the testing process will start when LIMIT is pressed.

NOTE The PASS and FAIL messages indicate the status of each test cycle, with the following exceptions:

- *When in the NORMAL, HIGH IMPEDANCE, or GUARD output-off state, the OFF message is displayed. The pass and fail conditions will be displayed as P OFF and F OFF respectively. When in the*

ZERO output-off state, the ZER message is displayed. The pass and fail conditions will be displayed as P ZER and F ZER respectively.

- If the source reaches the over-voltage protection (OVP) limit, the OVP message will be displayed. The pass and fail conditions will be displayed as P OVP and F OVP respectively.

Step 6: Stop testing process.

The testing process can be terminated at any time by again pressing LIMIT. When using a handler, the testing process will stop after the last DUT is tested.

Remote limit testing

Limit commands

Table 12-1 summarizes remote commands to control limit testing parameters, while Table 12-2 summarizes commands to control the Digital I/O port bit parameters for limit testing. See Section 18, “CALCulate2” and “SOURce2,” for more details on these commands.

NOTE The Model 2401 does not use the digital output lines of the Digital I/O port and does not have a component handler interface. The commands in Table 12-2 and Table 12-3 are not valid for the Model 2401 and will cause undefined header errors.

NOTE For instruments with the contact check option, see Appendix F for more information.

Table 12-1
Limit commands

Command*	Description*
:CALCulate2:FEED <name>	Select limit test input path (name = CALCulate[1], VOLTage, CURRent, or RESistance).
:CALCulate2:DATA?	Acquire limit test data.
:CALCulate2:LIMit:COMPLiance:FAIL <name>	Set Limit 1 fail condition. Name = IN (fail into compliance) or OUT (fail out of compliance).
:CALCulate2:LIMitX:LOWer <n>	Specify lower Limit X; X = 2, 3, 5-12 (n = limit).
:CALCulate2:LIMitX:UPPer <n>	Specify upper Limit X; X = 2, 3, 5-12 (n = limit).

Table 12-1 (cont.)

Limit commands

Command*	Description*
:CALCulate2:LIMit[1]:COMPLiance:SOURce2 <NRf> <NDN>	Specify limit 1 fail bit pattern. (NRf NDN = pattern).
:CALCulate2:LIMitX:LOWer:SOURce2 <NRf> <NDN>	Specify lower Limit X fail bit pattern for grading mode; X = 2, 3, 5-12 (NRf NDN = bit pattern).
:CALCulate2:LIMitX:UPPer:SOURce2 <NRf> <NDN>	Specify upper Limit X fail bit pattern for grading mode; X = 2, 3, 5-12 (NRf = bit pattern).
:CALCulate2:LIMitX:PASS:SOURce2 <NRf> <NDN>	Specify pass pattern for sorting mode (NRf NDN = bit pattern).
:CALCulate2:LIMit[1]:STATe <state>	Enable/disable Limit 1 test (state = ON or OFF).
:CALCulate2:LIMitX:STATe <state>	Enable/disable Limit X test; X = 2, 3, 5-12 (state = ON or OFF).
:CALCulate2:LIMit[1]:FAIL?	Query Limit 1 test result (0 = pass, 1 = fail).
:CALCulate2:LIMitX:FAIL?	Query Limit X test result; X = 2, 3, 5-12 (0 = pass, 1 = fail).
:CALCulate2:CLIMits:PASS:SOURce2 <NRf> <NDN>	Specify pass bit pattern (NRf NDN = pattern). Sorting mode only if limits 2, 3 and 5-12 disabled.
:CALCulate2:CLIMits:FAIL:SOURce2 <NRf> <NDN>	Specify fail bit pattern for sorting mode (NRf NDN = pattern).
:CALCulate2:CLIMits:PASS:SMLocation <location>	Specify pass source memory location. Location = NRf (memory #) or NEXT (next location).
:CALCulate2:CLIMits:FAIL:SMLocation <location>	Specify fail source memory location. (Location = NRf (memory#) or NEXT (next location).
:CALCulate2:CLIMits:BCONtrol <name>	Control I/O port pass/fail update. Name = IMMEDIATE (at failure) or END (end of sweep).
:CALCulate2:CLIMits:CLEar	Clear test results, reset I/O port.
:CALCulate2:CLIMits:CLEar:AUTO <state>	Enable/disable auto-clear (state = ON or OFF).
:CALCulate2:CLIMits:MODE <name>	Select Digital I/O control mode (name = GRADing or SORTing).

* LIMitX = LIMit2, LIMit3, LIMit5 through LIMit12. LIMit4 (Contact check option) not shown (see [Table 18-1](#) and [Appendix F](#)).

Table 12-2

Commands to control Digital I/O port for limit testing (not valid for the Model 2401)

Command	Description
:SOURce2:BSIZe <n>	Set Digital I/O port bit size (n = 3 or 4).
:SOURce2:TTL <NRf> <NDN>	Set I/O port bit pattern (NRf NDN = pattern).
:SOURce2:TTL?	Query actual output pattern.
:SOURce2:TTL4:MODE <name>	Set Digital I/O line 4 mode (name = EOTest or BUSY).
:SOURce2:TTL4:BSTate <state>	Set BUSY and EOT polarity (HI or LO).
:SOURce2:CLEar	Clear digital output lines.
:SOURce2:CLEar:AUTO <state>	Enable/disable I/O port auto clear (state = ON or OFF).
:SOURce2:CLEar:AUTO:DElay <n>	Set auto-clear delay (n = delay).

Table 12-3

Invalid limit commands for the Model 2401

Command*	Description*
:CALCulate2:LIMit[1]:COMpliance:SOURce2 <NRf> <NDN>	Specify limit 1 fail bit pattern. (NRf NDN = pattern).
:CALCulate2:LIMitX:LOWer:SOURce2 <NRf> <NDN>	Specify lower Limit X fail bit pattern for grading mode; X = 2, 3, 5-12 (NRf NDN = bit pattern).
:CALCulate2:LIMitX:UPPer:SOURce2 <NRf> <NDN>	Specify upper Limit X fail bit pattern for grading mode; X = 2, 3, 5-12 (NRf = bit pattern).
:CALCulate2:LIMitX:PASS:SOURce2 <NRf> <NDN>	Specify pass pattern for sorting mode (NRf NDN = bit pattern).
:CALCulate2:CLIMits:PASS:SOURce2 <NRf> <NDN>	Specify pass bit pattern (NRf NDN = pattern). Sorting mode only if limits 2, 3 and 5-12 disabled.
:CALCulate2:CLIMits:FAIL:SOURce2 <NRf> <NDN>	Specify fail bit pattern for sorting mode (NRf NDN = pattern).

* LIMitX = LIMit2, LIMit3, LIMit5 through LIMit12. LIMit4 (Contact check option) not valid for the Model 2401.

The programming example in [Table 12-4](#) tests a diode for two sets of upper and lower limits for a diode. This example is not valid for the Model 2401.

Table 12-4
Limits test programming example

Command	Description
*RST	Restore GPIB default conditions.
:SENS:FUNC:CONC OFF	Turn off concurrent functions.
:SOUR:FUNC CURR	Current source function.
:SENS:FUNC 'VOLT:DC'	Volts sense function.
:SOUR:CURR:TRIG 0.1	Output 100mA when triggered.
:SOUR:DEL 0.1	100ms source delay.
:CALC2:FEED VOLT	Use voltage for limits comparison.
:CALC2:LIM2:UPP 0.85	Limit 2 upper value = 0.85V.
:CALC2:LIM2:LOW 0.75	Limit 2 lower value = 0.75V.
:CALC2:LIM3:UPP 0.82	Limit 3 upper value = 0.82V.
:CALC2:LIM3:LOW 0.78	Limit 3 lower value = 0.78V.
:CALC2:CLIM:PASS:SOUR2 1	Digital I/O port = 0001 (1) when test passes.
:CALC2:LIM2:UPP:SOUR2 2	Digital I/O port = 0010 (2) when upper Limit 2 fails.
:CALC2:LIM2:LOW:SOUR2 2	Digital I/O port = 0010 (2) when lower Limit 2 fails.
:CALC2:LIM3:UPP:SOUR2 3	Digital I/O port = 0011 (3) when upper Limit 3 fails.
:CALC2:LIM3:LOW:SOUR2 3	Digital I/O port = 0011 (3) when lower Limit 3 fails.
:CALC2:CLIM:BCON IMM	Update Digital I/O port immediately after test.
:CALC2:LIM1:STAT 0	Turn off Limit 1 test.
:CALC2:LIM2:STAT 1	Turn on Limit 2 test.
:CALC2:LIM3:STAT 1	Turn on Limit 3 test.
:OUTPUT ON	Turn on source output.
:INIT	Trigger reading and limits test.
:OUTP OFF	Turn off output.
:CALC2:LIM2:FAIL?	Query Limit 2 test results (1 = discard diode).
:CALC2:LIM3:FAIL?	Query Limit 3 test results (1 = send diode to QA).

Digital I/O Port, Output Enable, & Output Configuration

- **Digital I/O port** — Discusses the various input/output lines on the Digital I/O Port as well as the +5V line that can be used to power external logic circuits.

NOTE The Model 2401 does not use the digital output lines of the Digital I/O port. Since the Model 2401 does not have a handler interface it cannot be used with a component handler to perform binning operations.

- **Output enable** — Describes how to use the Digital I/O Port as output enable cable.
- **Front panel output configuration** — Details configuration of the Digital I/O Port as an output enable as well as configuring main output off states.
- **Remote output configuration** — Summarizes the remote commands used to control the Digital I/O Port output enable and main output off states. A simple programming example is also provided.

Digital I/O port

The SourceMeter has a digital input/output port that can be used to control external digital circuitry, such as a handler that is used to perform binning operations when testing limits.

NOTE The Model 2401 does not use the digital output lines of the Digital I/O port. If using the Model 2401, ignore all information that pertains to binning operations.

Port configuration

The Digital I/O Port is located on the rear panel and is shown in [Figure 13-1](#).

NOTE The four digital output lines and the SOT line are primarily intended for limit testing with a device handler. See [Section 12, “Limit Testing,”](#) for details on performing limit tests and interfacing to handlers and [Section 11, “Triggering,”](#) for information on programming the SourceMeter to respond to the start-of-test (SOT) pulse from a handler.

NOTE The Model 2401 does not use pins 1 through 4 of the Digital I/O port. If using the Model 2401, ignore all information and actions pertaining to the digital output lines.

Figure 13-1
Digital I/O port

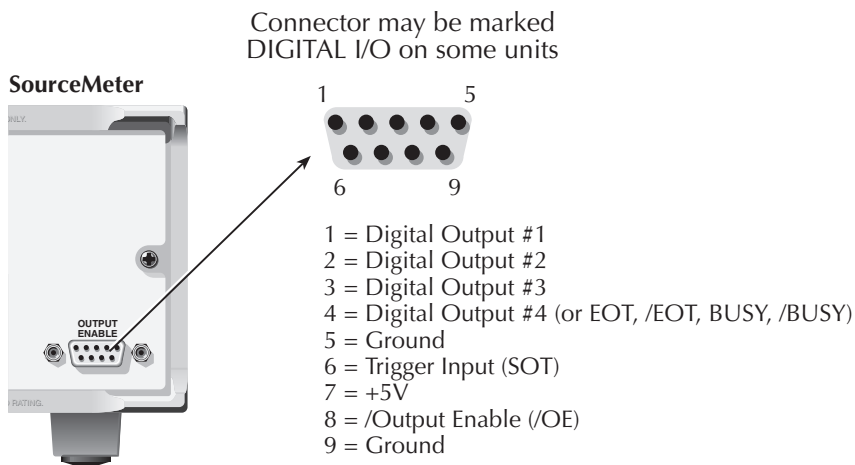

Digital output lines

The port provides four output lines. Each open-collector output can be set high (+5V) or low (0V). Each output line can source up to 2mA or sink up to 500mA. When using a category register handler for limit testing, output line #4 is typically used for the end-of-test (EOT) or BUSY pulse. This pulse from the SourceMeter signals the handler to perform the binning operation, or indicates a busy condition. (See [Section 12](#), “Configuring limit tests.”)

SOT line

The input line (SOT) is used by the handler to start limit testing. With the ↓STEST arm event selected ([Section 11](#), “Configuring triggering”), the handler must pulse SOT low in order to provide event detection which starts the testing process. With the ↑STEST arm event selected, the handler must pulse SOT high in order to provide event detection, which starts the testing process. With ↑↓STEST selected, either a high or low SOT pulse starts the testing process.

Output enable line

The output enable line (/OE) is intended for use with an output enable circuit on a device handler or test fixture. See “Output enable,” page 13-5, for more details.

+5V output

The Digital I/O Port provides a +5V output that can be used to drive external logic circuitry. Maximum current output for this line is 300mA. This line is protected by a self-resetting fuse (one hour recovery time).

Digital output configuration

There are two basic methods to connect external components to the digital output lines, sink operation and source operation.

Sink operation

[Figure 13-2](#) shows the basic output configuration for sink operation. Note that the external relay coil is connected between the digital output line (pins 1 to 4) and +5V (pin 7). With this configuration, the digital output line must be set LO to energize the relay, and the maximum sink current is 500mA.

Figure 13-2
Sink operation

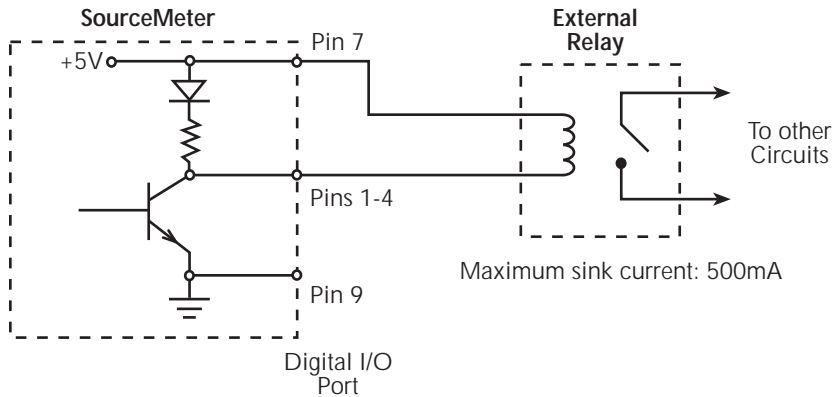

Source operation

Figure 13-3 shows the basic output configuration for source operation. In this case, the external relay coil is connected between the digital output line (pins 1 to 4) and ground (pin 9). With this configuration, the digital output line must be set HI to energize the relay, and the maximum source current is 2mA.

Figure 13-3
Source operation

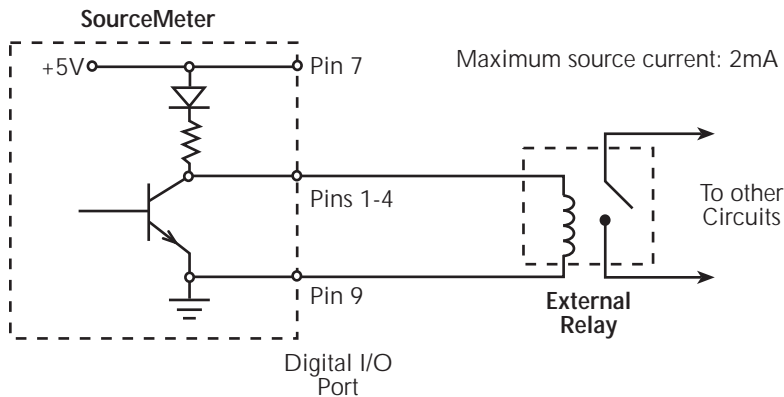

Controlling digital output lines

Although the digital output lines are primarily intended for use with a device handler for limit testing, they can also be used for other purposes such as controlling external relays or indicator lights. You can control these lines either from the front panel or via remote as covered below.

Front panel digital output control

Set digital output line logic levels from the front panel as follows:

1. Press the MENU key.
2. Select GENERAL, then press ENTER.
3. Select DIGOUT, then press ENTER.
4. Using the RANGE and cursor keys, set the digital output parameter to the desired decimal value ([Table 13-1](#)). For example, to set the output lines to L, H, H, H, set the digital output parameter value to 7.
5. Press EXIT to return to normal display.

Remote digital output control

Use the :SOURce2:TTL <NRf> command to control the digital output line logic levels, where <NRf> is the decimal value shown in [Table 13-1](#). For example, send the following command to set the output lines to L, H, L, H:

```
:SOUR2:TTL 5
```

Table 13-1
Digital output line settings

OUT 4	OUT 3	OUT 2	OUT 1	Decimal value*
L	L	L	L	0
L	L	L	H	1
L	L	H	L	2
L	L	H	H	3
L	H	L	L	4
L	H	L	H	5
L	H	H	L	6
L	H	H	H	7
H	L	L	L	8
H	L	L	H	9
H	L	H	L	10
H	L	H	H	11
H	H	L	L	12
H	H	L	H	13
H	H	H	L	14
H	H	H	H	15

L = Low (Gnd), H = High (>+3V)

* 0-7 in 3-bit mode, which is controlled by CONFIG LIMIT menu. (See [Section 12.](#)) 0-65535 with 2499-DIGIO 16-bit option.

Output enable line

NOTE The output enable line can be used by all Series 2400 SourceMeters.

The digital I/O port provides an output enable line for use with a test fixture output enable switch. When properly used, the OUTPUT of the SourceMeter will turn OFF when the lid of the test fixture is opened. See [Section 2, “Connections,”](#) for important safety information when using the test fixture switch.

When the output enable is turned on (see [“Front panel output configuration,”](#) page [13-7](#)), the output of the SourceMeter cannot be turned on unless the output enable line is pulled low through a switch to ground as shown in [Figure 13-4A](#). If the lid of the test fixture opens ([Figure 13-4B](#)), the switch opens, and the output enable line goes high turning the OUTPUT of the SourceMeter OFF (high impedance). The output can only be turned back on by first closing the lid of the test fixture and then pressing the OUTPUT ON/OFF key.

Figure 13-4
Using test fixture output enable

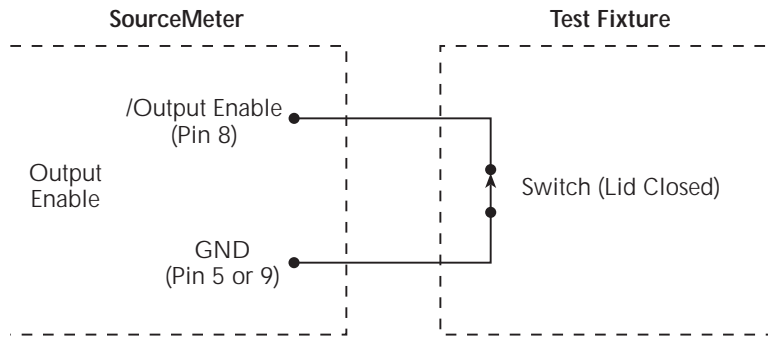

A. SourceMeter OUTPUT can be turned on.

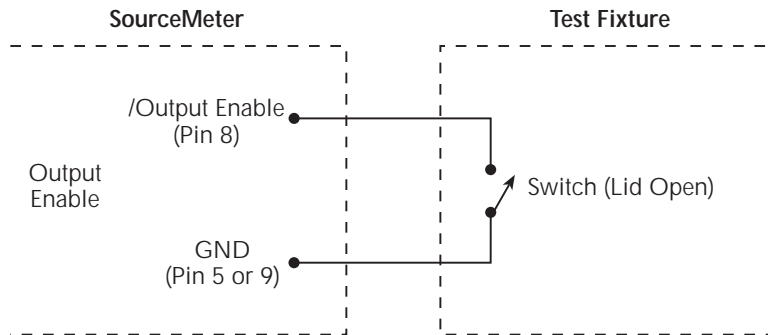

B. SourceMeter OUTPUT turns off.

NOTE Output enable can be driven by Digital I/O. Allow 100µs settling and response time. The Digital I/O lines are edge-sensitive, open-collector, and signals should be debounced to avoid erratic operation.

Front panel output configuration

The output is configured from the CONFIGURE OUTPUT menu and is structured as follows. Note that bullets indicate the primary items of the sweep menu, while dashes indicate options. Use [Section 1, "Rules to navigate menus,"](#) to check and/or change operate options.

Configure OUTPUT menu

Press CONFIG and then ON/OFF OUTPUT to display the menu. [Figure 13-5](#) shows the overall menu structure.

NOTE For the Model 2430 Pulse Mode, *ENABLE* is the only menu item that is displayed. For the Pulse Mode, the output-off state is always set to *NORMAL*, and auto output-off is always enabled.

- **ENABLE** — Use to ENABLE or DISABLE the output enable line of the Digital output. This line is used as an output enable for a test fixture. See “[Digital I/O port,](#)” page 13-2.
- **OFF STATE** — Use to select the OFF state of the output. See “[Output-off states,](#)” page 13-9, for details.
 - **HIGH IMPEDANCE** — When the OUTPUT is turned OFF, the output relay opens. This disconnects external circuitry from the input/output of the SourceMeter.
 - **NORMAL** — When the OUTPUT is turned off, the V-Source is selected and set to 0V. Current compliance is set to 0.5% full scale of the present current range.
 - **ZERO** — When the V-Source OUTPUT is turned off, the V-Source is set to 0V and current compliance is not changed. When the I-Source OUTPUT is turned off, the V-Source mode is selected and set to 0V. Current compliance is set to the programmed Source I value or to 0.5% full scale of the present current range, whichever is greater. Measurements are performed and displayed while the OUTPUT is off.
 - **GUARD** — When OUTPUT is turned OFF, the current source is selected and set to 0A. Voltage compliance is set to 0.5% full scale of the present voltage range.
- **AUTO OFF** — Use to ENABLE or DISABLE auto output off. When enabled, the OUTPUT will turn off after the measurement phase of every SDM cycle. The OUTPUT turns back on at the beginning of the next SDM cycle. When disabled, the OUTPUT stays on as long as the SourceMeter is operating within the trigger model (ARM annunciator on). With the OUTPUT enabled, pressing the ON/OFF key will disable the OUTPUT and disable auto output off.

NOTE Enabling auto output off with auto zero turned off may result in readings that are not fully settled because the source may not have settled when the A/D signal phase measurement is taken. Turning auto zero on may improve the readings because it adds a 450 μ s delay after the output is turned on, but before the A/D measurement is taken. If the readings have not settled, it will be necessary to increase the source delay.

Figure 13-5
Output configuration menu tree

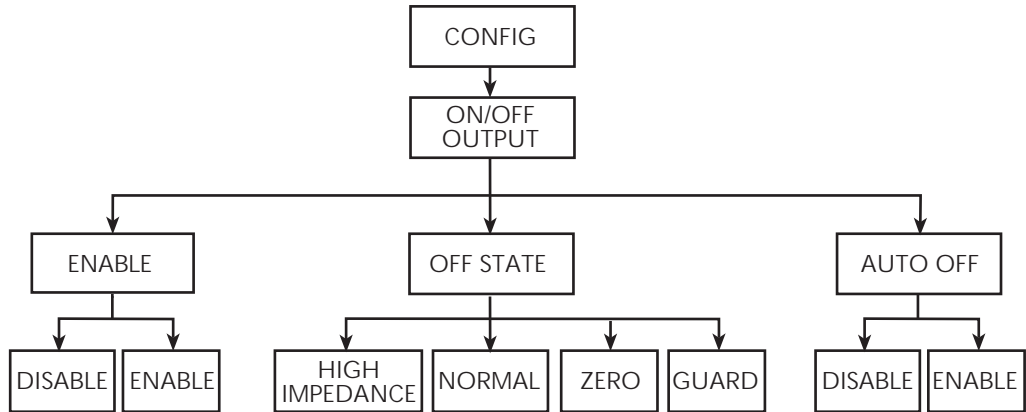

Output-off states

NOTE For the Model 2430 Pulse Mode, output-off is always set to *NORMAL*.

HIGH IMPEDANCE

With this output-off state, the output relay opens when the OUTPUT is turned OFF. This disconnects external circuitry from the input/output of the SourceMeter. To prevent excessive wear on the output relay, do not use this output off state for tests that turn the output off and on frequently (such as the Output Auto-Off mode). Note that there is a ~ 15msec settling time for the relay when the output is turned on.

NORMAL

When in this relatively high-impedance output-off state, the V-Source is selected and set to 0V. Current compliance is set to 0.5% full scale of the present current range. In theory, with the V-Source set to zero, the SourceMeter will not source or sink power. In practice, the source value may not be exactly at zero. Therefore, the SourceMeter may source or sink a very small amount of power. In most cases, this source or sink power level is not significant.

ZERO

When in this output-off state, the ZER message is displayed (instead of OFF), and the SourceMeter is configured as follows:

When the V-Source is the selected source:

- The programmed V-Source value remains on the display.
- Internally, the V-Source is set to 0V.
- The current compliance setting remains the same as the output-on value. Real and range compliance detection remains active.
- Measurements are performed and displayed.

When the I-Source is the selected source:

- The programmed I-Source value remains on the display.
- Internally, the V-Source is selected and set to 0V.
- Current compliance is set to the programmed Source I value or to 0.5% full scale of the present current range, whichever is greater.
- Measurements are performed and displayed.

While in the ZERO output-off state, the SourceMeter can be used as an I-Meter.

The ZERO output-off state can also be used with the V-Source and Output Auto-Off to generate very quick pulsed voltage waveforms. For example, with Output Auto-Off enabled, you can generate 0 to +5V pulses. While in this relatively low-impedance output-off state, the SourceMeter will be able to quickly dissipate (sink) current caused by high input capacitance (i.e., cable capacitance) or an external source. This results in fast settling time. If you instead used the NORMAL output-off state for this application, current would dissipate very slowly (slow settling time) resulting in distorted pulses.

WARNING Hazardous voltages (30V rms) can appear on the selected INPUT/OUTPUT LO terminal when generating quick, pulsed waveforms using the ZERO, AUTO-OFF output state. To eliminate this shock hazard, connect the LO terminal to earth ground. If using the front panel terminals, ground the front panel LO terminal. If using the rear panel terminals, ground the rear panel LO terminal. The ground connection can be made at the chassis ground screw on the rear panel or to a known safety earth ground.

GUARD

With this output-off state, the current source is selected and set to 0A. Voltage compliance is set to 0.5% full scale of the present voltage range. This output-off state should be used when performing 6-wire guarded ohms measurements or for any other load that uses an active source.

NOTE When changing the output-off state with the output off, the selected output-off state will be entered immediately.

On power-up, the SourceMeter will momentarily be in the HIGH IMPEDANCE output-off state before going to the selected power-on output-off state.

If an Over-Temperature condition or an output enable line violation occurs, the SourceMeter will go into the HIGH IMPEDANCE output-off state.

Output-off states and inductive loads

The output-off state you select for inductive loads depends on how much energy the inductor holds. The NORMAL output-off state is not recommended as it lowers the compliance setting. The ZERO or possibly GUARD state are better suited, as ZERO does not change the compliance setting and the GUARD output-off state would change the voltage source to a current source with a voltage compliance. The GUARD state is typically used only for guarded ohms measurements.

To protect the unit from inductive energy, the application may require a spark gap across the INPUT HI and LO terminals. The SourceMeter does not have internal spark gap protection, as some leakage current (nA) is associated with the protection circuits.

Remote output configuration

Output configuration commands

Table 13-2 summarizes output configuration commands. These commands include those to enable and disable the output enable line as well as commands to control output offstates. See Section 18, “OUTPut subsystem” and “SOURce subsystem” for more information

Output configuration programming example

Table 13-2

Output configuration commands

Command	Description
:OUTPut:ENABle:[STATE] <state> :OUTPut:ENABle:TRIPped? :OUTPut:SMODe <name>	Enable/disable output enable (state = ON or OFF). Query output enable line tripped state (1 = tripped). Select output-off mode (state = HIMPedance, NORMAl, ZERO, or GUARd). ¹
:SOURce:CLEAr :SOURce:CLEAr:AUTO <state>	Turn output source off when in idle state. Enable/disable auto output-off. State = OFF (output off after measurement) or ON (output stays on). ²
:SOURce:CLEAr:AUTO:MODE <name>	Auto clear mode. Name = ALWays (every reading; default) or TCOunt (ON when trigger layer entered; OFF when leaving trigger layer).

1. For the Model 2430 Pulse Mode, the output-off mode is always NORMAl. Selecting one of the other output-off states causes error +831.
2. For the Model 2430 Pulse Mode, auto output-off is always enabled. You can set auto output to be off, but it will not disable until the DC Mode of operation is selected.

Table 13-3 lists the command sequence for output configuration.

Table 13-3

Output configuration programming example

Command	Description
*RST	Restore GPIB defaults.
:SOUR:VOLT 10	Output 10V.
:OUTP:ENAB:STAT ON	Enable output enable line.*
:OUTP:SMOD HIMP	Select high impedance output-off mode.
:SOUR:CLE:AUTO ON	Enable auto-off mode.
:READ?	Trigger and acquire readings.

*Connect pins 8 and 9 of digital I/O port to simulate closed switch.

14

Remote Operations

- **Differences: remote vs. local operation** — Summarizes remote operation enhancements and local-to-remote and remote-to-local transitions.
- **Selecting an interface** — Describes how to select between the GPIB and RS-232 interfaces.
- **GPIB operation** — Covers GPIB bus standards, bus connections, and primary address selection.
- **General bus commands** — Describes general bus commands used for fundamental GPIB control.
- **Front panel GPIB operation** — Summarizes GPIB error messages, status indicators, and using the LOCAL key.
- **Programming syntax** — Describes the basic programming syntax for both common and SCPI commands.
- **RS-232 interface operation** — Outlines use of the RS-232 interface to control the SourceMeter via remote.

Differences: remote vs. local operation

Operation enhancements (remote operation)

There are some source-measure operations you can do over the IEEE-488 bus and RS-232 interface that you cannot do from the front panel; these are summarized below.

Math expressions

There are five math expressions available from the panel. All except the Percent Deviation are available as pre-defined math expressions for remote operation. However, remote operation allows you to create up to five user-defined math expressions for a total of nine expressions. An example program shows how to create Percent Deviation as a user-defined math expression.

Concurrent measurements

With the use of the TOGGLE key, you can measure (display) two functions concurrently. Using remote operation, you can perform concurrent measurements on all three functions (voltage, current, and resistance). See [Section 18, "SENSe1 subsystem,"](#) for details.

NOTE For the Model 2430, concurrent measurements cannot be performed while in the Pulse Mode. See [Section 5](#) for details on Pulse Mode operation.

Local-to-remote transition

When changing from local to remote operation, the following actions occur:

- The SourceMeter stops performing source-measure operations and returns to the idle state (ARM annunciator off).
- All sweep operations are aborted.
- All menus are exited.
- All pending front panel commands are aborted.
- Source and compliance editing are disabled.
- Data in the sample buffer is lost (i.e., :FETCh?, :CALC1:DATA?, and :CALC2:DATA? will not return any data until readings are taken while in remote).
- Concurrent measurements are enabled.
- All other settings are not affected, including those for the :TRACe buffer (data store).

Remote-to-local transition

When changing from remote to local operation, the following actions occur.

- The SourceMeter stops performing source-measure operations and returns to the idle state (ARM annunciator off).
- All sweep operations are aborted.
- All user-defined display messages are cancelled.
- The display is turned on (if it was previously turned off).
- Source autoranging is disabled.
- Concurrent measurements are enabled.
- If resistance was enabled, source readback is enabled.
- The display is set to the default toggle state.
- Readings are continuously taken (if OUTPUT is on).

Selecting an interface

The SourceMeter supports two built-in remote interfaces:

- GPIB (General Purpose Interface Bus)
- RS-232 interface

You can use only one interface at a time. The factory interface selection is the GPIB bus. You can select the interface only from the front panel. The interface selection is stored in non-volatile memory; it does not change when power has been off or after a remote interface reset.

The GPIB bus is the IEEE-488 interface. You must select a unique address for the Source-Meter. The address is displayed when the instrument is turned on. At the factory, the address is set to 24. The RS-232 interface is a serial interface.

An interface is selected and configured from the COMMUNICATIONS option of the Main Menu ([Section 1, “Main menu”](#)). For details on the programmable aspects of the interfaces, see [“Primary address,” page 14-4](#), and [“RS-232 interface operation,” page 14-13](#).

NOTE *When changing interface selections, the SourceMeter performs a power-on reset. To check and/or change options of the selected interface, you must re-enter the menu structure.*

GPIB operation

This section contains information about GPIB standards, bus connections, and primary address selection.

GPIB standards

The GPIB is the IEEE-488 instrumentation data bus with hardware and programming standards originally adopted by the IEEE (Institute of Electrical and Electronic Engineers) in 1975. The SourceMeter conforms to these standards:

- IEEE-488.1-1987
- IEEE-488.2-1992

The above standards define a syntax for sending data to and from instruments, how an instrument interprets this data, what registers should exist to record the state of the instrument, and a group of common commands. The SourceMeter also conforms to this standard:

- SCPI 1996.0 (Standard Commands for Programmable Instruments)

This standard defines a command language protocol. It goes one step farther than IEEE-488.2-1992 and defines a standard set of commands to control every programmable aspect of an instrument.

GPIB connections

To connect the SourceMeter to the GPIB bus, use a cable equipped with standard IEEE-488 connectors.

To allow many parallel connections to one instrument, stack the connectors. Two screws are located on each connector to ensure that connections remain secure.

To avoid possible mechanical damage, stack no more than three connectors on any one unit.

NOTE To minimize interference caused by electromagnetic radiation, use only shielded IEEE-488 cables. Available shielded cables from Keithley are Models 7007-1 and 7007-2.

Primary address

The SourceMeter ships from the factory with a GPIB primary address of 24. When the unit powers up, it momentarily displays the primary address. You can set the address to a value from 0 to 30, but do not assign the same address to another device or to a controller that is on the same GPIB bus (controller addresses are usually 0 or 21).

The primary address can be checked and/or changed from the COMMUNICATIONS option of the Main Menu ([Section 1](#), “Main menu”).

General bus commands

General commands are those commands, such as DCL, that have the same general meaning regardless of the instrument. [Table 14-1](#) lists the general bus commands.

Table 14-1
General bus commands

Command	Effect on SourceMeter
REN	Goes into remote when next addressed to listen.
IFC	Goes into talker and listener idle states.
LLO	LOCAL key locked out.
GTL	Cancel remote; restore SourceMeter front panel operation.
DCL	Returns all devices to known conditions.
SDC	Returns SourceMeter to known conditions.
GET	Initiates a trigger.
SPE, SPD	Serial polls the SourceMeter.

Front panel GPIB operation

This section describes aspects of the front panel that are part of GPIB operation, including messages, status indicators, and the LOCAL key.

Error and status messages

See [Appendix B](#) for a list of error and status messages associated with IEEE-488 programming. The instrument can be programmed to generate an SRQ, and command queries can be performed to check for specific error conditions.

GPIB status indicators

The REM (remote), TALK (talk), LSTN (listen), and SRQ (service request) annunciators show the GPIB bus status. Each of these indicators is described below.

REM

This indicator shows when the instrument is in the remote state. When the instrument is in remote, all front panel keys, except for the LOCAL key, are locked out.

When REM is turned off, the instrument is in the local state, and front panel operation is restored.

NOTE If LLO is in effect, LOCAL will be locked out. OUTPUT ON/OFF is still operational in remote. If ARM:SOUR is set to manual, the TRIG key will be active in remote.

TALK

This indicator is on when the instrument is in the talker active state.

LSTN

This indicator is on when the SourceMeter is in the listener active state.

SRQ

When this indicator is on, a service request has been generated. This indicator stays on until the serial poll byte is read or all the conditions that caused SRQ have been cleared. See [Section 15](#), “Status Structure,” for more information.

LOCAL key

The LOCAL key cancels the remote state and restores local operation of the instrument.

Pressing the LOCAL key also turns off the REM indicator and returns the display to normal if a user-defined message was displayed.

If the LLO (Local Lockout) command is in effect, the LOCAL key is also inoperative.

For safety reasons, the OUTPUT key will still be active in LLO.

Programming syntax

The information in this section covers syntax for both common commands and SCPI commands. For information not covered here, see the IEEE-488.2 and SCPI standards. See [Section 16](#) and [Section 18](#) for more details on common and SCPI commands, respectively.

Command words

Program messages are made up of one or more command words.

Commands and command parameters

Common commands and SCPI commands may or may not use a parameter. The following are some examples:

*SAV <NRf>	Parameter (NRf) required
*RST	No parameter used
:CALCulate1:STATe 	Parameter required
:SYSTem:PRESet	No parameter used

NOTE *At least one space between the command word and the parameter is required.*

Brackets [] — Some command words are enclosed in brackets ([]). These brackets are used to denote an optional command word that does not need to be included in the program message. For example:

```
:INITiate[:IMMediate]
```

These brackets indicate that :IMMediate is implied (optional) and does not have to be used. Thus, the above command can be sent in one of two ways:

```
:INITiate
```

or

```
:INITiate:IMMediate
```

Notice that the optional command is used without the brackets. When using optional command words in your program, do not include the brackets.

Parameter types — The following are some of the more common parameter types:

	Boolean — Used to enable or disable an instrument operation. 0 or OFF disables the operation, and 1 or ON enables the operation. Example: :CALCulate1:STATe ONEnable Calc 1 math expression
<name>	Name parameter — Select a parameter name from a listed group. Example: <name>= NEVer = NEXt :TRACe:FEED:CONTrol NEXt
<NRf>	Numeric representation format — This parameter is a number that can be expressed as an integer (e.g., 8), a real number (e.g., 23.6), or an exponent (2.3E6). Example: :SYSTem:KEY 11Press EXIT key from over the bus

- <n>** Numeric value — A numeric value parameter can consist of an NRf number or one of the following name parameters: DEFault, MINimum, MAXimum. When the DEFault parameter is used, the instrument is programmed to the *RST default value. When the MINimum parameter is used, the instrument is programmed to the lowest allowable value. When the MAXimum parameter is used, the instrument is programmed to the largest allowable value. Examples:
- :ARM:TIMer 0.1Sets timer to 100 msec.
 - :ARM:TIMer DEFaultSets timer to 0.1 sec.
 - :ARM:TIMer MINimumSets timer to 1 msec.
 - :ARM:TIMer MAXimumSets timer to 99999.99 sec.
- <numlist>** Numlist — Specify one or more numbers for a list. Example:
- :STATus:QUEue:ENABle (-110:-222) Enable errors -110 through -222
- <NDN>** Non-decimal numeric — This parameter is used to send values in the binary, octal, or hexadecimal format. The prefix designates the format type:
- #Bxx...x** #B specifies the binary format.
xx...x is the binary number (using 0s and 1s).
 - #Qxx...x** #Q specifies the octal format.
xx...x is the octal number (values 0 through 7).
 - #Hxx...x** #H specifies the hexadecimal format.
xx...x is the hexadecimal number (values 0 through 9 and A through F).
- Examples to send the decimal value 36 in the non-decimal formats:
- *ESE #b100100 Binary format
 - *ESE #q44 Octal format
 - *ESE #h24 Hexadecimal format
- Angle brackets < >** — Angle brackets (< >) are used to denote a parameter type. Do not include the brackets in the program message. For example:
- :OUTPut
- The indicates a Boolean-type parameter is required. Therefore, to enable the selected source, you must send the command with the ON or 1 parameter as follows:
- :OUTPut ON
 - :OUTPut 1

Query commands

This type of command requests (queries) the presently programmed status. It is identified by the question mark (?) at the end of the fundamental form of the command. Most commands have a query form:

:ARM:TIMer? Queries the timer interval.

Most commands that require a numeric parameter (<n>) can also use the DEFault, MINimum, and MAXimum parameters for the query form. These query forms are used to determine the *RST default value and the upper and lower limits for the fundamental command. Examples are:

:ARM:TIMer? DEFault Queries the *RST default value.

:ARM:TIMer? MINimum Queries the lowest allowable value.

:ARM:TIMer? MAXimum Queries the largest allowable value.

Case sensitivity

Common commands and SCPI commands are not case sensitive. You can use upper or lower case and any case combination. Examples:

*RST	= *rst
:DATA?	= :data?
:SYSTem:PRESet	= :system:preset

NOTE Using all upper case will result in slightly faster command response times.

Long-form and short-form versions

A SCPI command word can be sent in its long-form or short-form version. The command subsystem tables in [Section 18](#) provide the long-form version. However, the short-form version is indicated by upper case characters. Examples:

:SYSTem:PRESet	long-form
:SYST:PRES	short-form
:SYSTem:PRES	long-form and short-form combination

Note that each command word must be in long-form or short-form, and not something in between. For example, :SYSTe:PRESe is illegal and will generate an error. The command will not be executed.

Short-form rules

Use the following rules to determine the short-form version of any SCPI command:

- If the length of the command word is four letters or less, no short form version exists. Example:
- :auto = :auto

These rules apply to command words that exceed four letters:

- If the fourth letter of the command word is a vowel (including “y”), delete it and all the letters after it. Example
- :immediate = :imm
- If the fourth letter of the command word is a consonant, retain it but drop all the letters after it. Example:
- :format = :form
- If the command contains a question mark (; query) or a non-optional number included in the command word, you must include it in the short-form version. Example:
- :delay? = :del?
- Command words or characters that are enclosed in brackets ([]) are optional and need not be included in the program message.

NOTE *For fastest response to commands, always use short forms. Program messages*

A program message is made up of one or more command words sent by the computer to the instrument. Each common command is a three letter acronym preceded by an asterisk (*). SCPI commands are categorized in the :STATus subsystem and are used to explain how command words are structured to formulate program messages.

:STATus	Path (Root)
:OPERation	Path
:ENABle <Nrf>	Command and parameter
:ENABle?	Query command
:PRESet	Command

Single command messages

The above command structure has three levels. The first level is made up of the root command (:STATus) and serves as a path. The second level is made up of another path (:OPERation) and a command (:PRESet). The third path is made up of one command for the :OPERation path. The three commands in this structure can be executed by sending three separate program messages as follows:

```
:stat:oper:enab <NRf>
```

```
:stat:oper:enab?
```

```
:stat:pres
```

In each of the above program messages, the path pointer starts at the root command (:stat) and moves down the command levels until the command is executed.

Multiple command messages

You can send multiple command messages in the same program message as long as they are separated by semicolons (;). The following is an example showing two commands in one program message:

```
:stat:oper; :stat:oper:enab <NRf>
```

When the above is sent, the first command word is recognized as the root command (:stat). When the next colon is detected, the path pointer moves down to the next command level and executes the command. When the path pointer sees the colon after the semicolon (;), it resets to the root level and starts over.

Commands that are on the same command level can be executed without having to retype the entire command path. Example:

```
:stat:oper:enab <NRf>; enab?
```

After the first command (:enab) is executed, the path pointer is at the third command level in the structure. Since :enab? is also on the third level, it can be typed in without repeating the entire path name. Notice that the leading colon for :enab? is not included in the program message. If a colon were included, the path pointer would reset to the root level and expect a root command. Since :enab? is not a root command, an error would occur.

Command path rules

- Each new program message must begin with the root command, unless it is optional (e.g., [:SENSe]). If the root is optional, simply treat a command word on the next level as the root. For fastest operation, do not send optional data.
- The colon (:) at the beginning of a program message is optional and need not be used. However, eliminating the first colon will result in fastest operation. Example:
 - :stat:pres = stat:pres
- When the path pointer detects a colon (:) it moves down to the next command level. An exception is when the path pointer detects a semicolon (;), which is used to separate commands within the program message (see next rule).

- When the path pointer detects a colon (:) that immediately follows a semi-colon (;), it resets to the root level.
- The path pointer can only move down. It cannot be moved up a level. Executing a command at a higher level requires that you start over at the root command.

Using common and SCPI commands in the same message

Both common commands and SCPI commands can be used in the same message as long as they are separated by semicolons (;). A common command can be executed at any command level and will not affect the path pointer. Example:

```
:stat:oper:enab <NRf>; *ESE <NRf>
```

Program message terminator (PMT)

Each program message must be terminated with an LF (line feed), EOI (end or identify), or an LF+EOI. The bus will hang if your computer does not provide this termination. The following example shows how a multiple command program message must be terminated:

```
:outp on <PMT>
```

Command execution rules

- Commands execute in the order that they are presented in the program message.
- An invalid command generates an error and, of course, is not executed.
- Valid commands that precede an invalid command in a multiple command program message are executed.
- Valid commands that follow an invalid command in a multiple command program message are ignored.

Response messages

A response message is the message sent by the instrument to the computer in response to a query command program message.

Sending a response message

After sending a query command, the response message is placed in the Output Queue. When the SourceMeter is then addressed to talk, the response message is sent from the Output Queue to the computer.

Multiple response messages

If you send more than one query command in the same program message (see “Multiple command messages,” page 14-11), the multiple response messages for all the queries are sent to the computer when the SourceMeter is addressed to talk. The responses are sent in the order the query commands were sent and are separated by semicolons (;). Items within the same query are separated by commas (.). The following example shows the response message for a program message that contains four single item query commands:

```
0; 1; 1; 0
```

Response message terminator (RMT)

Each response is terminated with an LF (line feed) and EOI (end or identify). The following example shows how a multiple response message is terminated:

```
0; 1; 1; 0 <RMT>
```

Message exchange protocol

Two rules summarize the message exchange protocol:

Rule 1. You must always tell the SourceMeter what to send to the computer.

The following two steps must always be performed to send information from the instrument to the computer:

1. Send the appropriate query command(s) in a program message.
2. Address the SourceMeter to talk.

Rule 2. The complete response message must be received by the computer before another program message can be sent to the SourceMeter.

RS-232 interface operation

NOTE The programmable aspects of RS-232 operation (baud rate, data bits, parity, and terminator) are configured from the COMMUNICATION option of the Main Menu. (See Section 1, “Main menu.”)

Sending and receiving data

The RS-232 interface transfers data using 8 data bits, 1 stop bit, and no parity. Make sure the device you connect to the SourceMeter also uses these settings.

You can break data transmissions by sending a ^C (decimal 3) or ^X (decimal 18) character string to the instrument. This clears any pending operation and discards any pending output.

Baud rate

The baud rate is the rate at which the SourceMeter and the programming terminal communicate. Choose one of these available rates:

- 57600
- 38400
- 19200
- 9600
- 4800
- 2400
- 1200
- 600
- 300

The factory selected baud rate is 9600.

When you choose a baud rate, make sure the programming terminal or printer that you are connecting to the SourceMeter can support the baud rate you selected. Both the SourceMeter and the other device must be configured for the same baud rate.

Data bits and parity

The RS-232 interface can be configured to send/receive data that is 7 or 8 bits long using even, odd, or no parity. No parity is only valid when using 8 data bits.

Terminator

The SourceMeter can be configured to terminate each program message that it transmits to the controller with any of the following combinations of <CR> and <LF>:

<CR>	Carriage return
<CR+LF>	Carriage return and line feed
<LF>	Line feed
<LF+CR>	Line feed and carriage return

Flow control (signal handshaking)

Signal handshaking between the controller and the instrument lets the two devices communicate with each other about readiness to receive data. The SourceMeter does not support hardware handshaking (flow control).

Software flow control is in the form of XON and XOFF characters and is enabled when XON-XOFF is selected from the RS-232 FLOW CONTROL menu. When the input queue of the unit becomes more than `ifull`, the instrument issues an XOFF command. The control program should respond to this and stop sending characters until the SourceMeter issues the XON, which it will do once its input buffer has dropped below half-full. The SourceMeter recognizes XON and XOFF sent from the controller. An XOFF will cause the instrument to stop outputting characters until it sees an XON. Incoming commands are processed after the `<CR>` character is received from the controller.

If NONE is the selected flow control, there will be no signal handshaking between the controller and the SourceMeter. Data will be lost if transmitted before the receiving device is ready.

RS-232 connections

The RS-232 serial port is connected to the serial port of a computer using a straight-through RS-232 cable terminated with DB-9 connectors. Do not use a null modem cable. The serial port uses the transmit (TXD), receive (RXD), and signal ground (GND) lines of the RS-232 standard. [Figure 14-1](#) shows the rear panel connector for the RS-232 interface, and [Table 14-2](#) shows the pinout for the connector.

If your computer uses a DB-25 connector for the RS-232 interface, you will need a cable or adapter with a DB-25 connector on one end and a DB-9 connector on the other, wired straight through (not null modem).

Figure 14-1
RS-232 interface connector

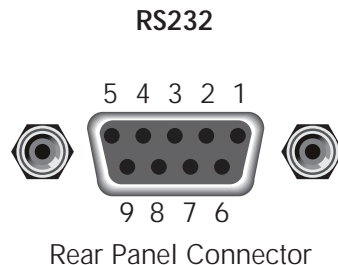

Table 14-2
RS-232 connector pinout

Pin number	Description
1	Not used
2	TXD, transmit data
3	RXD, receive data
4	Not used
5	GND, signal ground
6	Not used
7	RTS, ready to send
8	CTS, clear to send
9	Not used

NOTE: CTA and RTS are tied together.

[Table 14-3](#) provides pinout identification for the 9-pin (DB-9) or 25-pin (DB-25) serial port connector on the computer (PC).

Table 14-3
PC serial port pinout

Signal	DB-9 pin number	DB-25 pin number
DCD, data carrier detect	1	8
RXD, receive data	2	3
TXD, transmit data	3	2
DTR, data terminal ready	4	20
GND, signal ground	5	7
DSR, data set ready	6	6
RTS, request to send	7	4
CTS, clear to send	8	5
RI, ring indicator	9	22

Error messages

See [Appendix B](#) for RS-232 error messages.

15

Status Structure

- **Overview** — Provides an operational overview of the status structure for the SourceMeter.
- **Clearing registers and queues** — Covers the actions that clear (reset) registers and queues.
- **Programming and reading registers** — Explains how to program enable registers and read any register in the status structure.
- **Status byte and service request (SRQ)** — Explains how to program the Status Byte to generate service requests (SRQs). Shows how to use the serial poll sequence to detect SRQs.
- **Status register sets** — Provides bit identification and command information for the four status register sets; Standard Event Status, Operation Event Status, Measurement Event Status, and Questionable Event Status.
- **Queues** — Provides details and command information on the Output Queue and Error Queue.

Overview

The SourceMeter provides a series of status registers and queues allowing the operator to monitor and manipulate the various instrument events. The status structure is shown in [Figure 15-1](#). The heart of the status structure is the Status Byte Register. This register can be read by the user's test program to determine if a service request (SRQ) has occurred, and what event caused it.

Status byte and SRQ

The Status Byte Register receives the summary bits of four status register sets and two queues. The register sets and queues monitor the various instrument events. When an enabled event occurs, it sets a summary bit in the Status Byte Register. When a summary bit of the Status Byte is set and its corresponding enable bit is set (as programmed by the user), the RQS/MSS bit will set to indicate that an SRQ has occurred.

Status register sets

A typical status register set is made up of a condition register, an event register and an event enable register. A condition register is a read-only register that constantly updates to reflect the present operating conditions of the instrument.

When an event occurs, the appropriate event register bit sets to 1. The bit remains latched to 1 until the register is reset. When an event register bit is set and its corresponding enable bit is set (as programmed by the user), the output (summary) of the register will set to 1, which in turn sets the summary bit of the Status Byte Register.

Queues

The SourceMeter uses an Output Queue and an Error Queue. The response messages to query commands are placed in the Output Queue. As various programming errors and status messages occur, they are placed in the Error Queue. When a queue contains data, it sets the appropriate summary bit of the Status Byte Register.

Figure 15-1
SourceMeter status register structure

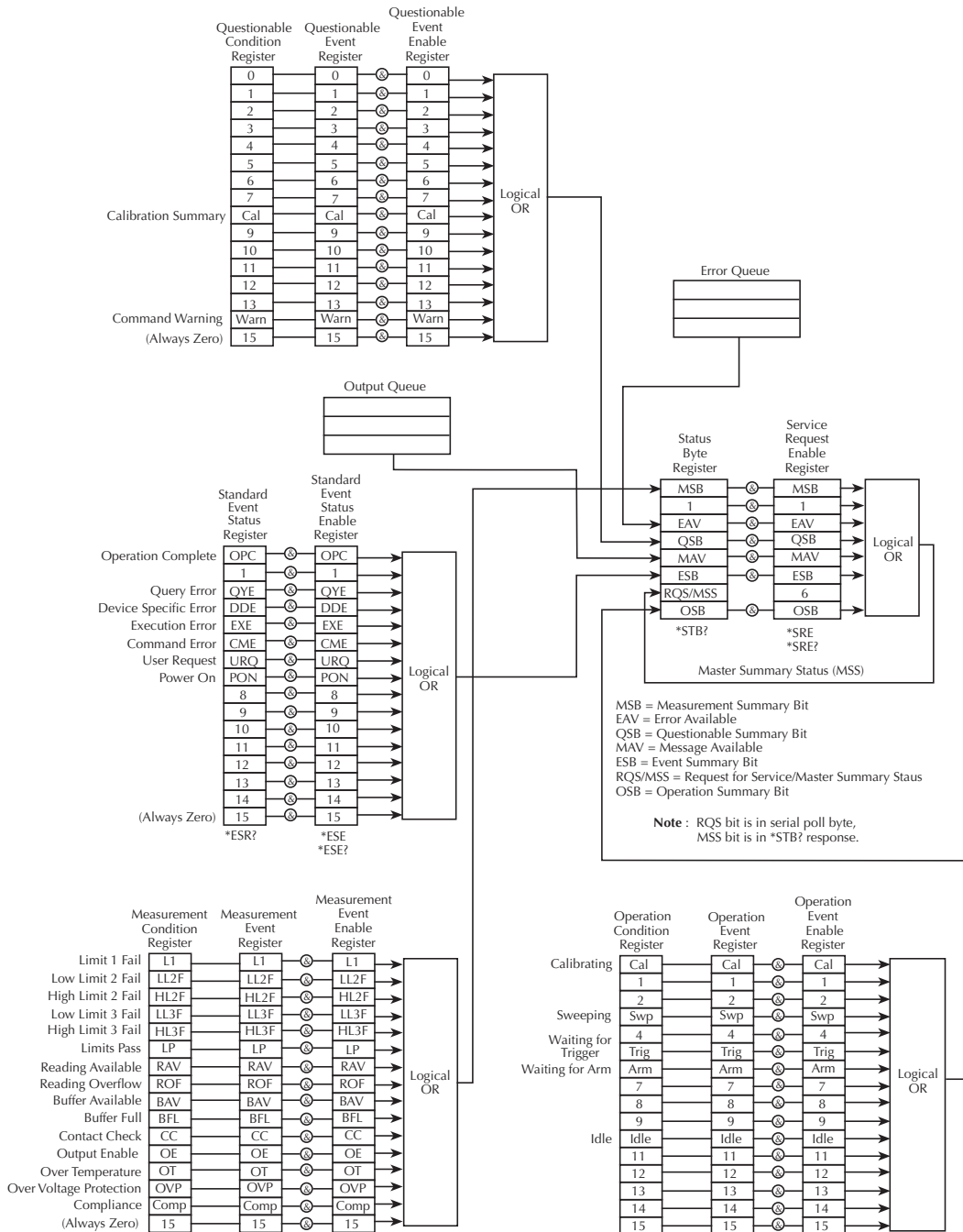

Clearing registers and queues

When the SourceMeter is turned on, the bits of all registers in the status structure are cleared (reset to 0), and the two queues are empty. Commands to reset the event and event enable registers, and the Error Queue are listed in [Table 15-1](#). In addition to these commands, any enable register can be reset by sending the 0 parameter value with the individual command to program the register.

NOTE *SYSTem:PRESet and *RST have no effect on status structure registers and queues.*

Table 15-1

Common and SCPI commands to reset registers and clear queues

Commands	Description	Ref.
To Reset Registers: *CLS	Reset all bits of the following event registers to 0: Standard Event Register Operation Event Register Measurement Event Register Questionable Event Register	Note 1
:STATus:PRESet	Reset all bits of the following enable registers to 0: Operation Event Enable Register Measurement Event Enable Register Questionable Event Enable Register	Note 1
To Clear Error Queue: *CLS	Clear all messages from Error Queue	Note 2
:STATus:QUEue:CLEar	Clear messages from Error Queue	Note 3
:SYSTem:ERRor:CLEar	Clear messages from Error Queue	Note 3

Notes:

1. The Standard Event Enable Register is not reset by STATus:PRESet or *CLS. Send the 0 parameter value with *ESE to reset all bits of that enable register to 0 (see [“Status byte and service request commands,” page 15-10](#)).
2. STATus:PRESet has no effect on the Error Queue.
3. Use either of the two clear commands to clear the Error Queue.

Programming and reading registers

Programming enable registers

The only registers that can be programmed by the user are the enable registers. All other registers in the status structure are read-only registers. The following explains how to ascertain the parameter values for the various commands used to program enable registers. The actual commands are covered later in this section (Table 15-3 and Table 15-6).

A command to program an event enable register is sent with a parameter value that determines the desired state (0 or 1) of each bit in the appropriate register. An enable register can be programmed using any of the following data formats for the parameter value; binary, decimal, hexadecimal, or octal.

The bit positions of the register (Figure 15-2) indicate the binary parameter value and decimal equivalent.

Figure 15-2
16-bit status register

Bit Position	B7	B6	B5	B4	B3	B2	B1	B0
Binary Value	0/1	0/1	0/1	0/1	0/1	0/1	0/1	0/1
Decimal	128	64	32	16	8	4	2	1
Weights	(2 ⁷)	(2 ⁶)	(2 ⁵)	(2 ⁴)	(2 ³)	(2 ²)	(2 ¹)	(2 ⁰)

A. Bits 0 through 7

Bit Position	B15	B14	B13	B12	B11	B10	B9	B8
Binary Value	0/1	0/1	0/1	0/1	0/1	0/1	0/1	0/1
Decimal	32768	16384	8192	4096	2048	1024	512	256
Weights	(2 ¹⁵)	(2 ¹⁴)	(2 ¹³)	(2 ¹²)	(2 ¹¹)	(2 ¹⁰)	(2 ⁹)	(2 ⁸)

B. Bits 8 through 15

The <NDN> (non-decimal numeric) parameter type is used to send non-decimal values. These values require a header (#B, #H or #Q) to identify the data format being sent. The letter in the header can be upper or lower case. The <NRf> (numeric representation format) parameter type is used to send decimal values, and does not use a header. The following examples show the proper parameter syntax for setting Bits B5, B3, and B2:

#b101100 Binary format (<NDN> parameter type)
 #h2C Hexadecimal format (<NDN> parameter type)
 #q54 Octal format (<NDN> parameter type)
 44 Decimal format (<NRf> parameter type)

Valid characters for the non-decimal parameter values are shown as follows:

<NDN> format	Valid characters
Binary	1s and 0s
Hexadecimal	0 through 9 and A through F
Octal	0 through 7

Reading registers

Any register in the status structure can be read by using the appropriate query (?) command. The following explains how to interpret the returned value (response message). The actual query commands are covered later in this section. (See [Table 15-3](#) and [Table 15-4](#) through [Table 15-7](#).)

The response message will be a value that indicates which bits in the register are set. That value (if not already binary) will have to be converted to its binary equivalent. For example, for a binary value of 100101, bits B5, B2, and B0 are set.

The returned value can be in the binary, decimal, hexadecimal, or octal format.

The

FORMat:SREGister command is used to select the data format for the returned value ([Table 15-2](#)).

For non-decimal formats, one of the following headers will accompany the returned value to indicate which format is selected:

#B = Header for binary values

#H = Header for hexadecimal values

#Q = Header for octal values

Table 15-2

Data format commands for reading status registers

Command	Description	Default
:FORMat:SREGister <name>	Select data format for reading status registers: <name> = ASCII Decimal format HEXadecimal Hexadecimal format OCTal Octal format BINary Binary format	ASCII

Status byte and service request (SRQ)

Service request is controlled by two 8-bit registers; the Status Byte Register and the Service Request Enable Register. Figure 15-3 shows the structure of these registers.

Figure 15-3
Status byte and service request (SRQ)

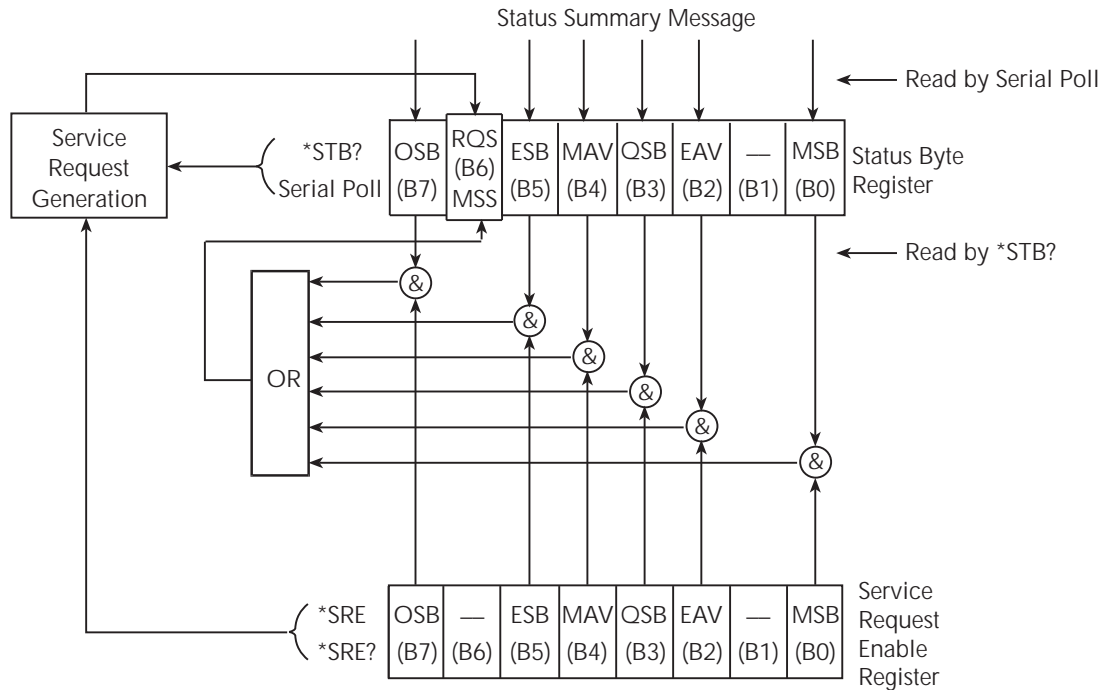

OSB = Operation Summary Bit
MSS = Master Summary Status
RQS = Request for Service
ESB = Event Summary Bit
Mav = Message Available
QSB = Questionable Summary Bit
EAV = Error Available
MSB = Measurement Summary Bit
& = Logical AND
OR = Logical OR

Status byte register

The summary messages from the status registers and queues are used to set or clear the appropriate bits (B0, B2, B3, B4, B5, and B7) of the Status Byte Register. These summary bits do not latch, and their states (0 or 1) are solely dependent on the summary messages (0 or 1). For example, if the Standard Event Register is read, its register will clear. As a result, its summary message will reset to 0, which in turn will reset the ESB bit in the Status Byte Register.

The bits of the Status Byte Register are described as follows:

- Bit B0, Measurement Summary Bit (MSB) — Set summary bit indicates that an enabled measurement event has occurred.
- Bit B1 — Not used.
- Bit B2, Error Available (EAV) — Set summary bit indicates that an error or status message is present in the Error Queue.
- Bit B3, Questionable Summary Bit (QSB) — Set summary bit indicates that an enabled questionable event has occurred.
- Bit B4, Message Available (MAV) — Set summary bit indicates that a response message is present in the Output Queue.
- Bit B5, Event Summary Bit (ESB) — Set summary bit indicates that an enabled standard event has occurred.
- Bit B6, Request Service (RQS)/Master Summary Status (MSS) — Set bit indicates that an enabled summary bit of the Status Byte Register is set.
- Bit B7, Operation Summary (OSB) — Set summary bit indicates that an enabled operation event has occurred.

Depending on how it is used, Bit B6 of the Status Byte Register is either the Request for Service (RQS) bit or the Master Summary Status (MSS) bit:

- When using the serial poll sequence of the SourceMeter to obtain the status byte (a.k.a. serial poll byte), B6 is the RQS bit. See “[Serial polling and SRQ](#)” for details on using the serial poll sequence.
- When using the *STB? command ([Table 15-3](#)) to read the status byte, B6 is the MSS bit.

Service request enable register

The generation of a service request is controlled by the Service Request Enable Register. This register is programmed by you and is used to enable or disable the setting of bit B6 (RQS/MSS) by the Status Summary Message bits (B0, B2, B3, B4, B5, and B7) of the Status Byte Register. As shown in [Figure 15-3](#), the summary bits are logically ANDed (&) with the corresponding enable bits of the Service Request Enable Register. When a set (1) summary bit is ANDed with an enabled (1) bit of the enable register, the logic "1" output is applied to the input of the OR gate and, therefore, sets the MSS/RQS bit in the Status Byte Register.

The individual bits of the Service Request Enable Register can be set or cleared by using the *SRE common command. To read the Service Request Enable Register, use the *SRE? query command. The Service Request Enable Register clears when power is cycled or a parameter value of 0 is sent with the *SRE command (i.e. *SRE 0). The commands to program and read the SRQ Enable Register are listed in [Table 15-3](#).

Serial polling and SRQ

Any enabled event summary bit that goes from 0 to 1 will set bit B6 and generate an SRQ (service request). In your test program, you can periodically read the Status Byte to check if an SRQ has occurred and what caused it. If an SRQ occurs, the program can, for example, branch to an appropriate subroutine that will service the request.

Typically, SRQs are managed by the serial poll sequence of the SourceMeter. If an SRQ does not occur, bit B6 (RQS) of the Status Byte Register will remain cleared, and the program will simply proceed normally after the serial poll is performed. If an SRQ does occur, bit B6 of the Status Byte Register will set, and the program can branch to a service subroutine when the SRQ is detected by the serial poll.

The serial poll automatically resets RQS of the Status Byte Register. This allows subsequent serial polls to monitor bit B6 for an SRQ occurrence generated by other event types. After a serial poll, the same event can cause another SRQ, even if the event register that caused the first SRQ has not been cleared.

The serial poll does not clear MSS. The MSS bit stays set until all Status Byte summary bits are reset.

SPE, SPD (serial polling)

The SPE, SPD General Bus Command sequence is used to serial poll the SourceMeter. Serial polling obtains the serial poll byte (status byte). Typically, serial polling is used by the controller to determine which of several instruments has requested service with the SRQ line.

Status byte and service request commands

The commands to program and read the Status Byte Register and Service Request Enable Register are listed in [Table 15-3](#). For details on programming and reading registers, see [“Programming enable registers,” page 15-5](#), and [“Reading registers,” page 15-6](#).

NOTE To reset the bits of the Service Request Enable Register to 0, use 0 as the parameter value for the *SRE command (i.e. *SRE 0).

Table 15-3

Status Byte and Service Request Enable Register commands

Command	Description	Default
*STB?	Read Status Byte Register.	
*SRE <NDN> or <NRf>	Program the Service Request Enable Register: <NDN>= #Bxx...xBinary format (each x = 1 or 0) = #HxHexadecimal format (x = 0 to FF) = #QxOctal format (x = 0 to 377) <NRf> = 0 to 255Decimal format	(Note)
*SRE?	Read the Service Request Enable Register	

Note: *CLS and STATus:PRESet have no effect on the Service Request Enable Register.

Programming example – set MSS (B6) when error occurs

The first command of sequence in [Table 15-4](#) enables EAV (error available). When an invalid command is sent (line 4), bits B2 (EAV) and B6 (MSS) of the Status Byte Register set to 1. The last command reads the Status Byte Register using the binary format (which directly indicates which bits are set). The command to select format (FORMat:SREGister) is documented in [Table 15-2](#). To determine the exact nature of the error, you will have to read the Error Queue (see [“Queues,” page 15-18](#)).

Table 15-4

Status byte programming example

Command	Description
*CLS	Clear Error Queue.
*SRE 4	Enable EAV.
FORM:SREG BIN	Select binary format.
*XYZ	Generate error.
*STB?	Read Status Byte Register.

Status register sets

As shown in [Figure 15-1](#), there are four status register sets in the status structure of the SourceMeter; Standard Event Status, Operation Event Status, Measurement Event Status, and Questionable Event Status.

NOTE See [Appendix B](#) for details on which register bits are set by specific error and status conditions.

Register bit descriptions

Standard Event Register

The used bits of the Standard Event Register (shown in [Figure 15-4](#)) are described as follows:

- Bit B0, Operation Complete — Set bit indicates that all pending selected device operations are completed and the SourceMeter is ready to accept new commands. This bit only sets in response to the *OPC? query command. See [Section 16](#) for details on *OPC and *OPC?.
- Bit B1 — Not used.
- Bit B2, Query Error (QYE) — Set bit indicates that you attempted to read data from an empty Output Queue.
- Bit B3, Device-Dependent Error (DDE) — Set bit indicates that an instrument operation did not execute properly due to some internal condition.
- Bit B4, Execution Error (EXE) — Set bit indicates that the SourceMeter detected an error while trying to execute a command.
- Bit B5, Command Error (CME) — Set bit indicates that a command error has occurred.
- Command errors include:
 - IEEE-488.2 syntax error — SourceMeter received a message that does not follow the defined syntax of the IEEE-488.2 standard.
 - Semantic error — SourceMeter received a command that was misspelled or received an optional IEEE-488.2 command that is not implemented.
 - The instrument received a Group Execute Trigger (GET) inside a program message.
- Bit B6, User Request (URQ) — Set bit indicates that the LOCAL key on the SourceMeter front panel was pressed.
- Bit B7, Power ON (PON) — Set bit indicates that the SourceMeter has been turned off and turned back on since the last time this register has been read.

Figure 15-4
Standard event status

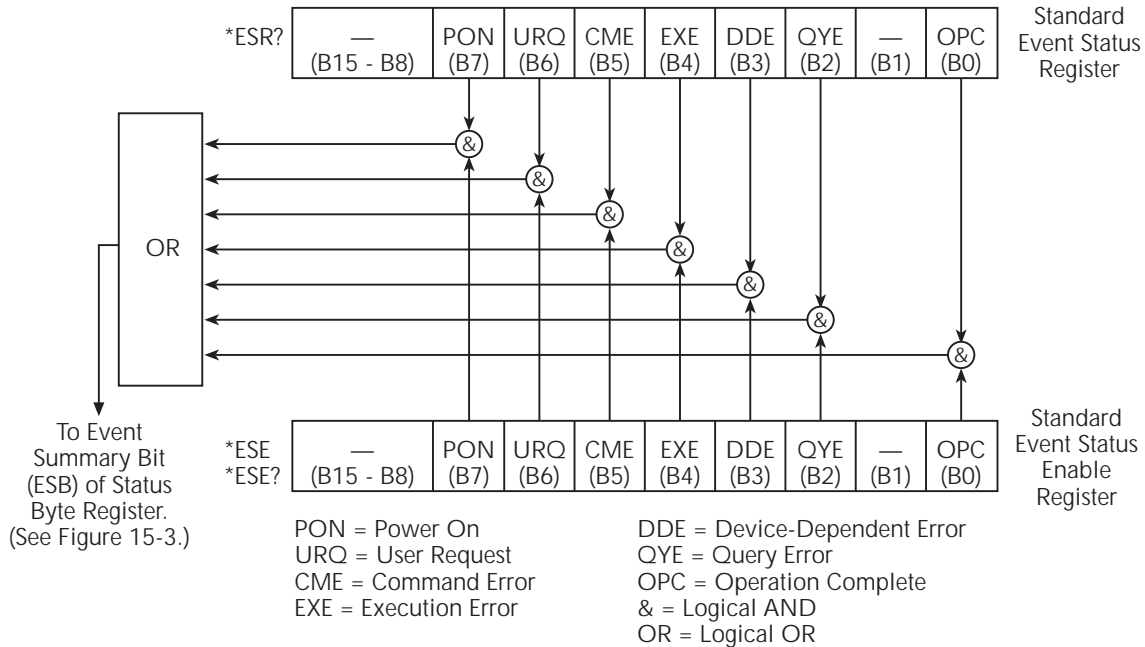

Operation Event Register

The used bits of the Operation Event Register (shown in [Figure 15-5](#)) are described as follows:

- Bit B0, Calibrating (Cal) — Set bit indicates that the SourceMeter is calibrating.
- Bits B1 and B2 — Not used.
- Bit B3, Sweeping (Swp) — Set bit indicates the instrument is performing a sweep operation.
- Bit B4 — Not used.
- Bit B5, Waiting for Trigger Event (Trig) — Set bit indicates that the SourceMeter is in the trigger layer waiting for a TLINK trigger event to occur.
- Bit B6, Waiting for Arm Event (Arm) — Set bit indicates that the SourceMeter is in the arm layer waiting for an arm event to occur.
- Bits B7 through B9 — Not used.
- Bit B10, Idle State (Idle) — Set bit indicates the SourceMeter is in the idle state.
- Bits B11 through B15 — Not used.

Figure 15-5
Operation event status

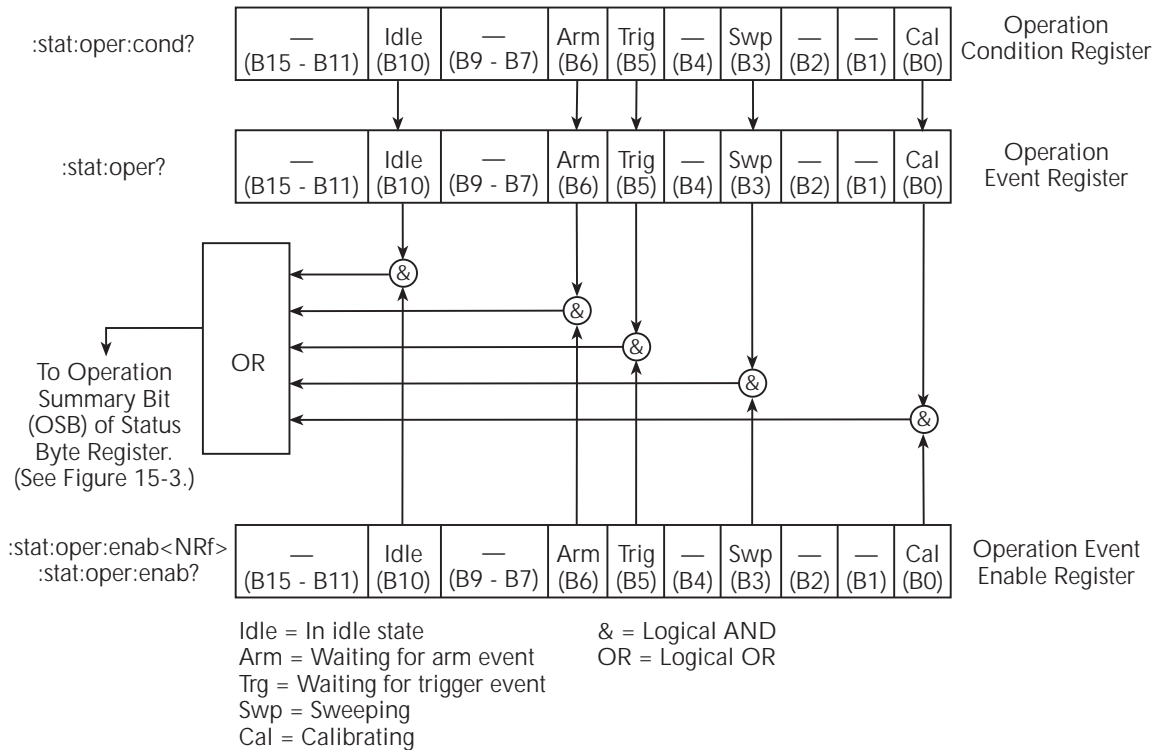

Measurement Event Register

The used bits of the Measurement Event Register (shown in [Figure 15-6](#)) are described as follows:

- Bit B0, Limit 1 Fail (L1) — Set bit indicates that the Limit 1 test has failed.
- Bit B1, Low Limit 2 Fail (LL2) — Set bit indicates that the Low Limit 2 test has failed.
- Bit B2, High Limit 2 Fail (HL2) — Set bit indicates that the High Limit 2 test has failed.
- Bit B3, Low Limit 3 Fail (LL3) — Set bit indicates that the Low Limit 3 test has failed.
- Bit B4, High Limit 3 Fail (HL3) — Set bit indicates that the High Limit 3 test has failed.
- Bit B5, Limits Pass (LP) — Set bit indicates that all limit tests passed.
- Bit B6, Reading Available (RAV) — Set bit indicates that a reading was taken and processed.

- Bit B7, Reading Overflow (ROF) — Set bit indicates that the volts or amps reading exceeds the selected measurement range of the SourceMeter.
- Bit B8, Buffer Available (BAV) — Set bit indicates that there are at least two readings in the buffer.
- Bit B9, Buffer Full (BFL) — Set bit indicates that the trace buffer is full.
- Bit B10 — Limit 4 - Contact Check (see [Appendix F](#)).
- Bit B11, Output Enable Asserted (Int) — Set bit indicates that the output enable line is at digital low (asserted). The source output can be turned on.
- Bit B12, Over Temperature (OT) — Set bit indicates that an over temperature condition exists. The source output cannot be turned on.
- Bit B13, Over Voltage Protection (OVP) — Set bit indicates that the source is being limited at the programmed limit level.
- Bit B14, Compliance (Comp) — Set bit indicates that the source is in compliance.
- Bit B15 — Not used.

Figure 15-6
Measurement event status

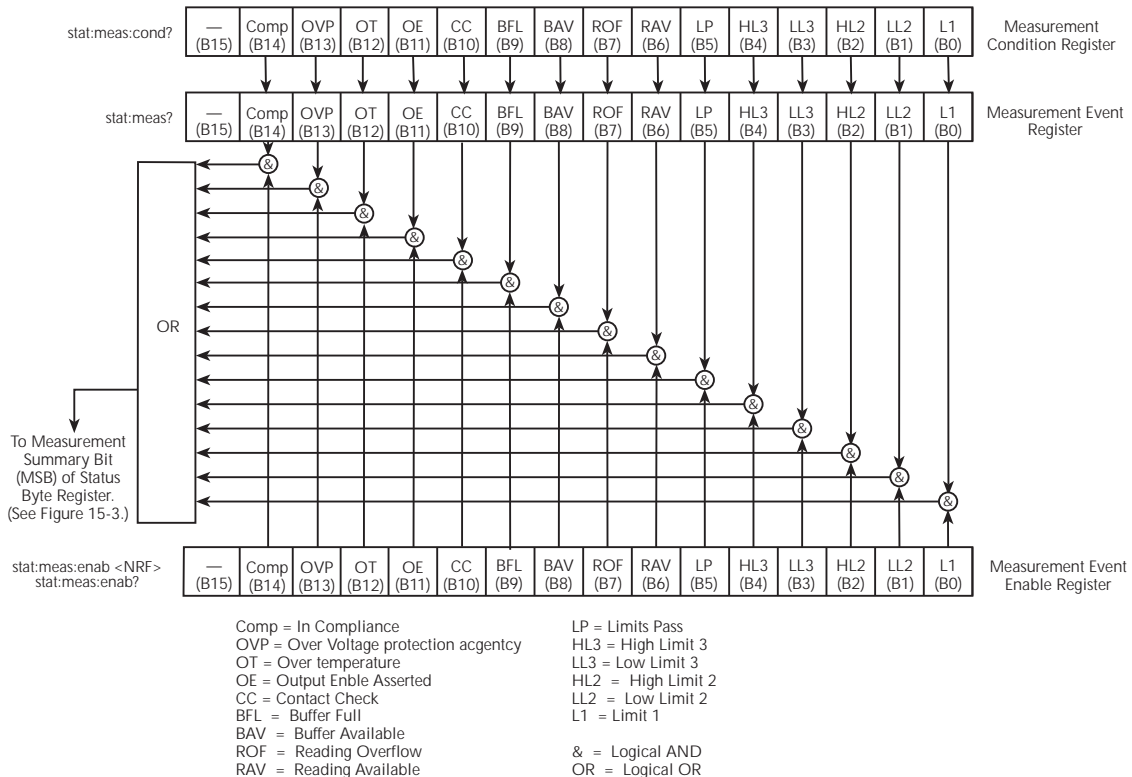

Questionable Event Register

The used bits of the Questionable Event Register (shown in [Figure 15-7](#)) are described as follows:

- Bits B0 through B7 — Not used.
- Bit B8, Calibration Summary (Cal) — Set bit indicates that an invalid calibration constant was detected during the power-up sequence. This error will clear after successful calibration of the instrument.
- Bits B9 through B13 — Not used.
- Bit B14, Command Warning (Warn) — Set bit indicates that a Signal Oriented Measurement Command parameter has been ignored.
- Bit B15 — Not used.

Figure 15-7
Questionable event status

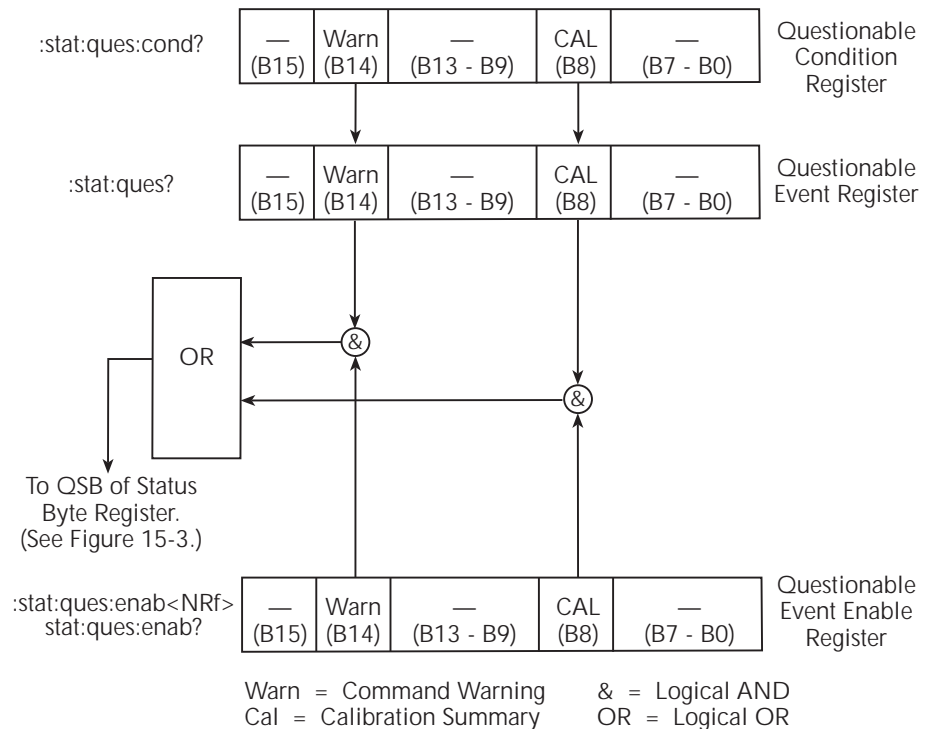

Condition registers

As [Figure 15-1](#) shows, each status register set (except the Standard Event Register set) has a condition register. A condition register is a real-time, read-only register that constantly updates to reflect the present operating conditions of the instrument. For example, while the SourceMeter is in the idle state, bit B10 (Idle) of the Operation Condition Register will be set. When the instrument is taken out of idle, bit B10 clears.

The commands to read the condition registers are listed in [Table 15-5](#). For details on reading registers, see [“Reading registers,” page 15-6](#).

Table 15-5

Condition register commands

Command	Description
:STATus:OPERation:CONDition?	Read Operation Condition Register.
:STATus:MEASurement:CONDition?	Read Measurement Condition Register.
:STATus:QUESTionable:CONDition?	Read Questionable Condition Register.

Event registers

As [Figure 15-1](#) shows, each status register set has an event register. When an event occurs, the appropriate event register bit sets to 1. The bit remains latched to 1 until the register is reset. Reading an event register clears the bits of that register. *CLS resets all four event registers.

The commands to read the event registers are listed in [Table 15-6](#). For details on reading registers, see [“Reading registers,” page 15-6](#).

Table 15-6

Event register commands

Command	Description	Default
*ESR?	Read Standard Event Status Register.	(Note)
:STATus:OPERation:[:EVENT]?	Read Operation Event Register.	
:STATus:MEASurement:[:EVENT]?	Read Measurement Event Register.	
:STATus:QUESTionable:[:EVENT]?	Read Questionable Event Register.	

Note: Power-up and *CLS resets all bits of all event registers to 0. STATus:PRESet has no effect.

Event enable registers

As [Figure 15-1](#) shows, each status register set has an enable register. Each event register bit is logically ANDed (&) to a corresponding enable bit of an enable register. Therefore, when an event bit is set and the corresponding enable bit is set (as programmed by the user), the output (summary) of the register will set to 1, which in turn sets the summary bit of the Status Byte Register.

The commands to program and read the event enable registers are listed in [Table 15-7](#). For details on programming and reading registers, see “[Programming enable registers](#),” page 15-5, and “[Reading registers](#),” page 15-6.

NOTE The bits of any enable register can be reset to 0 by sending the 0 parameter value with the appropriate enable command (i.e. `STATus:OPERation:ENABle 0`).

Table 15-7

Event enable registers commands

Command	Description	Default
*ESE <NDN> or <NRf>	Program Standard Event Enable Register. (See “Parameters.”)	(Note)
*ESE?	Read Standard Event Enable Register.	
STATus	STATus Subsystem:	
:OPERation	Operation Event Enable Register:	
:ENABle <NDN> or <NRf>	Program enable register. (See “Parameters.”)	
:ENABle?	Read enable register.	
:MEASurement	Measurement Event Enable Register:	
:ENABle <NDN> or <NRf>	Program enable register. (See “Parameters.”)	
:ENABle?	Read enable register.	
:QUEStionable	Questionable Event Enable Register:	
:ENABle <NDN> or <NRf>	Program enable register. (See “Parameters.”)	
:ENABle?	Read Measurement Event Enable Register:	
Parameters:		
<NDN> = #Bxx...x Binary format (each x = 1 or 0)		
= #Hx Hexadecimal format (x = 0 to 7FFF)		
= #Qx Octal format (x = 0 to 77777)		
<NRf> = 0 to 32767 Decimal format		

Note: Power-up and STATus:PRESet reset all bits of all enable registers to 0. *CLS has no effect.

Programming example — program and read register set

The command sequence in [Table 15-8](#) programs and reads the measurement register set. Registers are read using the binary format (which directly indicates

which bits are set). The command to select format (FORMat:SREGister) is documented in [Table 15-2](#).

Table 15-8

Program and read register programming example

Command	Description
FORM:SREG BIN	Select binary format to read registers.
STAT:MEAS:ENAB 512	Enable BFL (buffer full).
STAT:MEAS:COND?	Read Measurement Condition Register.
STAT:MEAS?	Read Measurement Event Register.

Queues

The SourceMeter uses two queues, which are first-in, first-out (FIFO) registers:

- Output Queue — Used to hold reading and response messages.
- Error Queue — Used to hold error and status messages. (See [Appendix B](#).)

The SourceMeter status model ([Figure 15-1](#)) shows how the two queues are structured with the other registers.

Output queue

The output queue holds data that pertains to the normal operation of the instrument. For example, when a query command is sent, the response message is placed in the Output Queue.

When data is placed in the Output Queue, the Message Available (MAV) bit in the Status Byte Register sets. A data message is cleared from the Output Queue when it is read. The Output Queue is considered cleared when it is empty. An empty Output Queue clears the MAV bit in the Status Byte Register.

A message is read from the Output Queue by addressing the SourceMeter to talk after the appropriate query is sent.

Error queue

The Error Queue holds error and status messages. When an error or status event occurs, a message that defines the error/status is placed in the Error Queue.

When a message is placed in the Error Queue, the Error Available (EAV) bit in the Status Byte Register is set. An error/status message is cleared from the Error Queue when it is read. The Error Queue is considered cleared when it is empty. An empty Error Queue clears the EAV bit in the Status Byte Register.

The Error Queue holds up to 10 error/status messages. The commands to read the Error Queue are listed in [Table 15-9](#). When you read a single message in the Error Queue, the “oldest” message is read and then removed from the queue. If the queue becomes full, the message “350, ‘Queue Overflow’” will occupy the last memory location. On power-up, the Error Queue is empty. When empty, the message “0, No Error” is placed in the queue.

Messages in the Error Queue are preceded by a code number. Negative (-) numbers are used for SCPI-defined messages, and positive (+) numbers are used for Keithley-defined messages. The messages are listed in [Appendix B](#). As shown in [Table 15-7](#), there are commands to read the entire message (code and message) or the code only.

On power-up, all error messages are enabled and will go into the Error Queue as they occur. Status messages are not enabled and will not go into the queue. As listed in [Table 15-9](#), there are commands to enable and/or disable messages. For these commands, the <list> parameter is used to specify which messages to enable or disable. The messages are specified by their codes. The following examples show various forms for using the <list> parameter.

<list> = (-110)	Single message
= (-110:-222)	Range of messages (-110 through -222)
= (-110:-222, -220)	Range entry and single entry (separated by a comma)

When you enable messages, messages not specified in the list are disabled. When you disable messages, each listed message is removed from the enabled list.

NOTE To prevent all messages from entering the Error Queue, send the enable command along with the null list parameter as follows:
`STATus:QUEue:ENABLE ()`.

Table 15-9
Error queue commands

Command	Description	Default
STATus :QUEue [:NEXT]? :ENABle <list> :ENABle? :DISABle <list> :DISABle? :CLEar	STATus Subsystem: Read Error Queue: Read and clear oldest error/status (code and message). Specify error and status messages for Error Queue. Read the enabled messages. Specify messages not to be placed in queue. Read the disabled messages. Clear messages from Error Queue.	(Note 1) (Note 2) (Note 2)
SYSTem :ERRor [:NEXT]? :ALL? :COUNT? :CODE [:NEXT]? :ALL? :CLEar	SYSTem Subsystem: Read Error Queue: Read and clear oldest error/status (code and message). Read and clear all errors/status (code and message). Read the number of messages in queue. Code numbers only: Read and clear oldest error/status (code only). Read and clear all errors/status (codes only). Clear messages from Error Queue.	(Note 1)

Notes:

1. Power-up and *CLS empties the Error Queue. STATus:PRESet has no effect.
2. Power-up enables error messages and disables status messages. *CLS and STATus:PRESet have no effect.

Programming example — read error queue

The following command reads the error queue:

```
STAT:QUE?
```

16

Common Commands

- **Command summary** — Lists the IEEE-488.2 common commands used by the SourceMeter.
- **Command reference** — Provides a detailed reference for all common commands except for those associated with the status structure, discussed in [Section 15](#).

Command summary

Common commands (summarized in [Table 16-1](#)) are device commands that are common to all devices on the bus. These commands are designated and defined by the IEEE-488.2 standard. Most of these commands are described in detail in this section.

NOTE *The following common commands associated with the status structure are covered in [Section 15](#): *CLS, *ESE, *ESE?, *ESR?, *SRE, *SRE?, and *STB?.*

Table 16-1
IEEE-488.2 common commands and queries

Mnemonic	Name	Description
*CLS	Clear status	Clears all event registers and Error Queue. ¹
*ESE <NRf>	Event enable command	Program the Standard Event Enable Register. ¹
*ESE?	Event enable query	Read the Standard Event Enable Register. ¹
*ESR?	Event status register query	Read and clear the Standard Event Enable Register. ¹
*IDN?	Identification query	Returns the manufacturer, model number, serial number, and firmware revision levels of the unit.
*OPC	Operation complete command	Set the Operation Complete bit in the Standard Event Register after all pending commands have been executed.
*OPC?	Operation complete query	Places an ASCII "1" into the Output Queue when all pending selected device operations have been completed.
*OPT?	Options Query	Queries installed options. Response message indicates the presence or absence of options. For example, if response message reads "0", then no options are present. If the response message reads CONTACT CHECK, then a Contact-Check option is present.
*RCL <NRf>	Recall command	Returns the SourceMeter to the user-saved setup.
*RST	Reset command	Returns the SourceMeter to the *RST default conditions.
*SAV <NRf>	Save command	Saves the present setup as the user-saved setup.
*SRE <NRf>	Service request enable command	Programs the Service Request Enable Register. ¹
*SRE?	Service request enable query	Reads the Service Request Enable Register. ¹
*STB?	Status byte query	Reads the Status Byte Register. ¹
*TRG	Trigger command	Sends a bus trigger to the SourceMeter.
*TST?	Self-test query	Performs a checksum test on ROM and returns the result.
*WAI	Wait-to-continue command	Wait until all previous commands are executed.

¹ Status commands are covered in [Section 15](#).

Command reference

***IDN? — identification query**

Reads identification code

The identification code includes the manufacturer, model number, serial number, and firmware revision levels and is sent in the following format:

KEITHLEY INSTRUMENTS INC., MODEL nnnn, xxxxxxx, yyyy/zzzzz /a/d

Where: nnnn is the model number.
xxxxxxx is the serial number.
yyyy/zzzzz is the firmware revision level of the digital board ROM and display board ROM, including date and time of build.
a is the analog board revision level.
d is the digital board revision level.

***OPC — operation complete**

Sets OPC bit

***OPC? — operation complete query**

Places a "1" in output queue

When *OPC is sent, the OPC bit in the Standard Event Register will set after all pending command operations are complete. When *OPC? is sent, an ASCII "1" is placed in the Output Queue after all pending command operations are complete.

Typically, either one of these commands is sent after the INITiate command. The INITiate command is used to take the instrument out of idle in order to perform measurements. While operating within the trigger model layers, all sent commands (except DCL, SDC, IFC, SYSTem:PRESet, *RST, *RCL, *TRG, GET, and ABORt) will not execute.

After all programmed operations are completed, the instrument returns to the idle state at which time all pending commands (including *OPC and/or *OPC?) are executed. After the last pending command is executed, the OPC bit and/or an ASCII "1" is placed in the Output Queue.

***SAV <Nrf> — save**

Save present setup in memory

***RCL <Nrf> — recall**

Return to setup stored in memory

Parameters: 0 = Memory location 0
1 = Memory location 1
2 = Memory location 2
3 = Memory location 3
4 = Memory location 4

Use the *SAV command to save the present instrument setup configuration in memory for later recall. Any control affected by *RST can be saved by the *SAV command. The *RCL command is used to restore the instrument to the saved setup configuration. Five setup configurations can be saved and recalled.

The SourceMeter ships from the factory with SYSTem:PRESet defaults loaded into the available setup memory. If a recall error occurs, the setup memory defaults to the SYSTem:PRESet values.

****RST — reset**

Return SourceMeter to GPIB defaults

When the *RST command is sent, the SourceMeter performs the following operations:

- Returns the SourceMeter to the GPIB default conditions (see “Default” column of SCPI tables in [Section 18](#)).
- Cancels all pending commands.
- Cancels response to any previously received *OPC and *OPC? commands.

***TRG — trigger**

Send bus trigger to SourceMeter

Use the *TRG command to issue a GPIB trigger to the SourceMeter. It has the same effect as a group execute trigger (GET).

Use the *TRG command as an event to control operation. The SourceMeter reacts to this trigger if BUS is the programmed arm control source. The control source is programmed from the TRIGger subsystem.

NOTE Details on triggering are covered in [Section 11](#).

****TST? — self-test query**

Run self test and read result

Use this query command to perform a checksum test on ROM. The command places the coded result (0 or 1) in the Output Queue. When the SourceMeter is addressed to talk, the coded result is sent from the Output Queue to the computer.

A returned value of zero (0) indicates that the test passed, and a value of one (1) indicates that the test failed.

WAI — wait-to-continue*Wait until previous commands are com-**

Effectively, the *WAI command is a No-Op (no operation) for the SourceMeter and thus, does not need to be used.

Two types of device commands exist:

- Sequential commands — A command whose operations are allowed to finish before the next command is executed.
- Overlapped commands — A command that allows the execution of subsequent commands while device operations of the Overlapped command are still in progress.

The *WAI command is used to suspend the execution of subsequent commands until the device operations of all previous Overlapped commands are finished.

The *WAI command is not needed for Sequential commands.

17

SCPI Signal Oriented Measurement Commands

- **Command summary** — Summarizes those commands used to configure and acquire readings.
- **Configuring measurement function** — Provides detailed information on commands to configure the measurement function.
- **Acquiring readings** — Describes commands to acquire post-processed readings, both trigger and acquire readings, and to perform a single measurement.

Command summary

The signal oriented measurement commands are used to acquire readings. You can use these high-level instructions to control the measurement process. These commands are summarized in [Table 17-1](#).

Table 17-1

Signal oriented measurement command summary

Command	Description
:CONFigure:<function>	Configures SourceMeter for measurements on specified function. Output turns on.
:CONFigure?	Returns active function(s).
:FETCh?	Requests latest readings.
:READ?	Performs an :INITiate and a :FETCh?.
:MEASure[:<function>]?	One-shot measurement mode. Performs a :CONFigure and a :READ?.

Configuring measurement function

NOTE For the Model 2430, the :CONFigure commands are not valid while in the Pulse Mode. They result in error +831: Invalid in Pulse Mode.

:CONFigure:<function>

Parameters	<function> = CURRENT[:DC]	Amps function
	VOLTage[:DC]	Volts function
	RESistance	Ohms function

Query :CONFigure? Returns active function(s).

Description This command configures the instrument to a specific setup for measurements on the specified function. The :READ? command is then typically used to trigger a specified number of measurements. See “:READ?”.

When this command is sent, the SourceMeter will be configured as follows:

- Select specified function.
- All controls related to the selected function are defaulted to the *RST values.
- The event control source of the Trigger Model is set to Immediate.

- The count values of the Trigger Model are set to one.
- The Delay of the Trigger Model is set to zero.
- All math calculations are disabled.
- Buffer operation is disabled.
- Autozero is enabled.
- The source output will turn on.

WARNING When **:CONFigure** is sent, the output will turn on. Beware of hazardous voltage that may be present on the output terminals.

NOTE This command is automatically asserted when the **:MEASure?** command is sent.

Acquiring readings

:FETCh?

Description This query command requests the latest post-processed readings stored in the sample buffer (see [Appendix C, "Data Flow"](#)). After sending this command and addressing the SourceMeter to talk, the readings are sent to the computer. This command does not affect the instrument setup.

This command does not trigger source-measure operations; it simply requests the last available readings. Note that this command can repeatedly return the same readings. Until there are new readings, this command continues to return the old readings. For example, assume that the SourceMeter performed 20 source-measure operations. The **:FETCh?** command will request the readings for those 20 source-measure operations. If **:FETCh?** is sent while performing source-measure operations (ARM annunciator on), it will not be executed until the SourceMeter goes back into idle.

The readings that are acquired depend on which data elements are selected ([Section 18, "Data elements"](#)), and what the instrument is presently programmed to source-measure. Measure readings take priority over source readings, and functions not sourced or measured are assigned the NAN (not a number) value of +9.91e37.

For example, assume that voltage, current and resistance readings are selected as data elements, and the instrument is programmed to Source V and Measure I. A reading string acquired by :FETCh? will include the programmed V-Source value and the I-Measure reading. The reading for resistance will be NAN since resistance was not measured.

If the SourceMeter is instead programmed to Source V and Measure V, the voltage reading will be the V-Measure reading (not the programmed V-Source value). Both current and resistance readings will be NANs (current is not measured or sourced).

NOTE The :FETCh? command is automatically asserted when the :READ? or :MEASure? command is sent.

See [Appendix C](#), “Data Flow,” for a detailed explanation on how data flows through the various operation blocks of the SourceMeter. It clarifies the types of readings that are acquired by the various commands to read data.

[[:SENSe[1]]:DATA[:LATest]?

Description This command works exactly like FETCh?, except that it returns only the most recent reading.

:READ?

Description This command is used to trigger and acquire readings. The number of readings depends on how the trigger model is configured. For example, if configured for 20 source-measure operations (arm count 1, trigger count 20), then 20 sets of readings will be acquired after the Source-Meter returns to the idle state.

When this command is sent, the following commands execute in the order that they are presented:

- :INITiate
- :FETCh?

The :INITiate command starts operation by taking the instrument out of idle.

After all source-measure operations are completed, the SourceMeter goes back into idle at which time the :FETCh? command is executed. The readings are sent to the computer and displayed when the Source-Meter is addressed to talk.

Note that if auto output-off is disabled (:SOURce1:CLEAr:AUTO OFF), then the output must be turned on before you can perform a :READ?. The output will then remain on after all source-measure operations are completed.

If auto output-off is enabled (:SOURce1:CLEAr:AUTO ON), then the output will automatically turn on at the beginning of each SDM (source-delay-measure) cycle and turn off after each measurement.

NOTE For the Model 2430 Pulse Mode, the output will turn on when the :READ? command is sent.

See [Appendix C, “Data Flow,”](#) for a detailed explanation on how data flows through the various operation blocks of the SourceMeter. It clarifies the type of readings that are acquired by the various commands to read data.

:MEASure[:<function>]?

Parameters <function> = CURRent[:DC]Amps function
VOLTage[:DC]Volts function
RESistanceOhms function

Description This command combines other signal oriented measurement commands to perform a “one-shot” measurement and acquire the reading. Note that if a function is not specified, the measurement will be done on the function that is presently selected.

When this command is sent, the following commands execute in the order that they are presented.

- :CONFigure:<function>
- :READ?

When :CONFigure is executed, the instrument goes into a “one-shot” measurement mode. See :CONFigure for more details.

When :READ? is executed, its operations will then be performed. In general, another :ABORt is performed, then an :INITiate, and finally a FETCh? to acquire the readings. See :READ? for more details.

When :MEASure? is sent, the source turns on and a single measurement is performed. If auto output-off is enabled (:SOURce1:CLEAr:AUTO ON), then the output will turn off after the measurement is completed. If auto output-off is disabled (:SOURce1:CLEAr:AUTO OFF), then the output will remain on after the measurement is completed.

WARNING With auto output-off disabled, the output will remain on after the one-shot source-measure operation is performed. Beware of hazardous voltage that may be present on the output terminals.

SCPI Command Reference

- **Reference tables** — Summarizes each SCPI command subsystem.
- **SCPI subsystems** — Provides detailed information on all commands in each SCPI subsystem.

Reference tables

Table 18-1 through Table 18-11 summarize the commands for each SCPI subsystem. The following list includes the SCPI subsystem, table number where each command is summarized, and the page number where detailed reference information begins.

Summary table	Subsystem	Reference page
Table 18-1	CALCulate *	page 18-26
Table 18-2	DISPlay	page 18-44
Table 18-3	FORMat	page 18-47
Table 18-4	OUTPUt	page 18-55
Table 18-5	ROUte	page 18-57
Table 18-6	SENSe	page 18-58
Table 18-7	SOURce *	page 18-71
Table 18-8	STATus	page 18-101
Table 18-9	SYSTem	page 18-103
Table 18-10	TRACe	page 18-114
Table 18-11	TRIGger	page 18-116

* Invalid CALCulate2 commands for the Model 2401 are listed in [Table 12-2](#). All SOURce2 commands are invalid for the Model 2401 and are listed in [Table 12-3](#). They will cause undefined header errors.

General notes:

- Brackets ([]) are used to denote optional character sets. These optional characters do not have to be included in the program message. Do not use brackets in the program message.
- Angle brackets (< >) are used to indicate parameter type. Do not use angle brackets in the program message.
- The Boolean parameter () is used to enable or disable an instrument operation. 1 or ON enables the operation, and 0 or OFF disables the operation.
- Upper case characters indicate the short-form version for each command word.
- Default Parameter — Listed parameters are both the *RST and :SYSTem:PRE-Set defaults, unless noted otherwise. Notes are located at the end of each table.
- SCPI — A checkmark (✓) indicates that the command and its parameters are SCPI confirmed. An unmarked command indicates that it is a SCPI command, but does not conform to the SCPI standard set of commands. It is not a recognized command by the SCPI consortium. SCPI confirmed commands that use one or more non-SCPI parameters are explained by notes.
- Source Memory — A checkmark (✓) indicates that the parameters associated with the specified command are saved in any one of 100 memory locations by the :SOURce[1]:MEMory:SAVE command.

Table 18-1

CALCulate command summary

Command	Description	Default parameter	SCPI	Source memory
:CALCulate[1]	Subsystem to control CALC1:		✓	
:MATH	Path to configure and control math expressions:		✓	
[:EXPRession] <form>	Define math expression using standard math operator symbols.		✓	
[:EXPRession]?	Query math expression.		✓	
:CATalog?	Query list of math expression names.		✓	
:NAME <name>	Create name for new user-defined expression.	Power	✓	✓
:NAME?	Query created name.		✓	
[:DEFine] <form>	Same as :EXPRession <form> command.		✓	
:DELete	Path to delete user-defined expressions.		✓	
[:SEL] <name>	Delete specified expression.		✓	
:ALL	Delete all user-defined expressions.		✓	
:UNITs <name>	Define units name for math expression (3ASCII characters).	"W"		✓
:UNITs?	Query math expression units name.			
:STATe 	Enable or disable math expression.	OFF	✓	✓
:STATe?	Query state of math expression.		✓	
:DATA	Path to CALC1 data.		✓	
:LATest?	Return only most recent math result.			
:DATA?	Read result of math expression.		✓	
:CALCulate2	Subsystem to control CALC2:		✓	
:FEED <name>	Select input path (CALCulate[1], CURRent, VOLTage, or RESistance).	VOLT	✓	✓
:FEED?	Query CALC2 feed.		✓	
:NULL	Path to configure and control REL:			
:OFFSet <NRf>	Specify REL value (-9.999999e20 to 9.999999e20).	0		✓
:OFFSet?	Query REL value.			
:STATe 	Enable or disable REL.	OFF		✓
:STATe?	Query state of REL.			
:ACQuire	Automatically acquire REL value.			
:DATA	Path to CALC2 data.		✓	
:LATest?	Return only most recent REL or LIMIT result.			
:DATA?	Read math result of CALC2.		✓	

Table 18-1 (continued)

CALCulate command summary

Command	Description	Default parameter	SCPI	Source memory
:CALCulate2				
:LIMit[1]	Path to control LIMIT 1 test:		✓	
:COMPLiance	Configure Limit 1 test:			
:FAIL <name>	Specify fail condition (IN or OUT of compliance).	IN		✓
:FAIL?	Query fail condition.			
:SOURce2 <NRf> <NDN>	Specify output fail pattern (0 to 7, 3-bit; 0 to 15, 4-bit).	15		✓
:SOURce2?	Query fail bit pattern.*			
:STATe 	Enable or disable Limit 1 test.	OFF	✓	✓
:STATe?	Query state of Limit 1 test.		✓	
:FAIL?	Returns result of Limit 1 test: 0 (pass) or 1 (fail).		✓	
:LIMit2	Path to control LIMIT 2 test:		✓	
:UPPer	Configure upper limit:		✓	
[:DATA] <n>	Specify upper limit (-9.999999e20 to 9.999999e20).	1	✓	✓
[:DATA]?	Query upper limit.		✓	
:SOURce2 <NRf> <NDN>	Specify output fail pattern for grading mode (0 to 7, 3-bit; 0 to 15, 4-bit).	15		✓
:SOURce2?	Query fail bit pattern.*			
:LOWer	Configure lower limit:		✓	
[:DATA] <n>	Specify lower limit (-9.999999e20 to 9.999999e20).	-1	✓	✓
[:DATA]?	Query lower limit.		✓	
:SOURce2 <NRf> <NDN>	Specify output fail pattern for grading mode (0 to 7, 3-bit; 0 to 15, 4-bit).	15		✓
:SOURce2?	Query fail bit pattern.*			
:PASS	Path to specify pass pattern for sorting mode:			
:SOURce2 <NRf> <NDN>	Specify output pass pattern (0 to 7, 3-bit; 0 to 15, 4-bit).	15	✓	✓
:SOURce2?	Query pass bit pattern.*			
:STATe 	Enable or disable Limit 2 test.	OFF	✓	✓
:STATe?	Query state of Limit 2 test.		✓	
:FAIL?	Return result of Limit 2 test: 0 (pass) or 1 (fail).		✓	

Table 18-1 (continued)

CALCulate command summary

Command	Description	Default parameter	SCPI	Source memory
:CALCulate2				
:LIMit3	Path to control LIMIT 3 test:		✓	
:UPPer	Configure upper limit:		✓	
[:DATA] <n>	Specify upper limit (-9.999999e20 to 9.999999e20).	1	✓	✓
[:DATA]?	Query upper limit.		✓	
:SOURce2 <NRf> <NDN>	Specify output fail pattern (0 to 7, 3-bit; 0 to 15, 4-bit).	15		✓
:SOURce2?	Query fail bit pattern.*			
:LOWer	Configure lower limit:		✓	
[:DATA] <n>	Specify lower limit (-9.999999e20 to 9.999999e20).	-1	✓	✓
[:DATA]?	Query lower limit.		✓	
:SOURce2 <NRf> <NDN>	Specify output fail pattern for grading mode. (0 to 7, 3-bit; 0 to 15, 4-bit).	15		✓
:SOURce2?	Query fail bit pattern.*			
:PASS	Path to specify pass pattern for sorting mode:			
:SOURce2 <NRf> <NDN>	Specify output pass pattern (0 to 7, 3-bit; 0 to 15, 4-bit).	15	✓	✓
:SOURce2?	Query pass bit pattern.*			
:STATe 	Enable or disable Limit 3 test.	OFF	✓	✓
:STATe?	Query state of Limit 3 test.		✓	
:FAIL?	Return result of Limit 3 test: 0 (pass) or 1 (fail).		✓	
:LIMit4	Path for LIMIT 4 test (contact check option only).			
:SOURce2 <NRf> <NDN>	Specify output fail pattern (0 to 7, 3-bit; 0 to 15, 4-bit).	15		
:SOURce2?	Query fail bit pattern.*			
:STATe 	Enable or disable Limit 4 test.	OFF	✓	✓
:STATe?	Query state of Limit 4 test.		✓	
:FAIL?	Return result of Limit 4 test: 0 (pass) or 1 (fail).		✓	

Table 18-1 (continued)

CALCulate command summary

Command	Description	Default parameter	SCPI	Source memory
:CALCulate2				
:LIMit5...12	Path to control LIMIT 5 to LIMIT 12 tests (see Note):		✓	
:UPPer	Configure upper limit:		✓	
[:DATA] <n>	Specify upper limit (-9.999999e20 to 9.999999e20).	1	✓	✓
[:DATA]?	Query upper limit.		✓	
:SOURce2 <NRf> <NDN>	Specify output fail pattern for grading mode (0 to 7, 3-bit; 0 to 15, 4-bit).	15		✓
:SOURce2?	Query fail bit pattern.*			
:LOWer	Configure lower limit:		✓	
[:DATA] <n>	Specify lower limit (-9.999999e20 to 9.999999e20).	-1	✓	✓
[:DATA]?	Query lower limit.		✓	
:SOURce2 <NRf> <NDN>	Specify output fail pattern for grading mode (0 to 7, 3-bit; 0 to 15, 4-bit).	15		✓
:SOURce2?	Query fail bit pattern.*			
:PASS	Path to specify pass pattern for sorting mode:			
:SOURce2 <NRf> <NDN>	Specify output pass pattern (0 to 7, 3-bit; 0 to 15, 4-bit).	15	✓	✓
:SOURce2?	Query pass bit pattern.			
:STATe 	Enable or disable Limit 5 to 12 tests.	OFF	✓	✓
:STATe?	Query state of Limit 5 to 12 tests.		✓	
:FAIL?	Return result of Limit 5 to 12 tests: 0 (pass) or 1 (fail).		✓	
:CLIMits	Composite limits for Limit 1 through Limit 12:			
:BCONtrol <name>	Specify when to send binning info to handler. A limit test is performed (IMMediate) or after a sweep, list, or memory sequence (END).	IMM		
:BCONtrol?	Query binning control.			
:MODE <name>	Set how limit results control Digital I/O lines (GRADing or SORTing).	GRAD		
:MODE?	Query limit results control of Digital I/O lines.			

Note: Use LIMit5 through LIMit12 to control Limit 5 through Limit 12 tests respectively. For example, send :LIM5:STAT ON to enable Limit 5; send LIM10:FAIL? to return the result of Limit 10.

Table 18-1 (continued)

CALCulate command summary

Command	Description	Default parameter	SCPI	Source memory
:CALCulate2				
:CLEAR [:IMMEDIATE]	Clear test results: Clear latest limit test result and reset Digital I/O port back to :SOURCE2:TTL settings.			
:AUTO 	Enable or disable clearing of test results when :INITiate command is sent.	ON		
:AUTO?	Query state of auto clear.			
:PASS	Define pass digital output pattern. Sorting mode only if limits 2, 3, 5-12 disabled.			
:SOURCE2 <NRf> <NDN>	Specify output pass pattern: (0 to 7, 3-bit; 0 to 15, 4-bit).	15		✓
:SOURCE2?	Query pass bit pattern.*			
:SMLOCATION <NRf> NEXT	Specify next PASS Source Memory Sweep location (NEXT location or 1 to 100).	NEXT		✓
:SMLOCATION?	Query PASS memory location.			
:FAIL	Define fail digital output pattern:			
:SOURCE2 <NRf> <NDN>	Specify output fail pattern: (0 to 7, 3-bit; 0 to 15, 4-bit).	15		✓
:SOURCE2?	Query fail bit pattern.*			
:SMLOCATION <NRf> NEXT	Specify next FAIL Source Memory location (NEXT location or 1 to 100).	NEXT		
:SMLOCATION?	Query FAIL memory location.			
:CALCulate3	Subsystem to control CALC3:		✓	
:FORMAT <name>	Specify math format (MEAN, SDEViation, MAXimum, MINimum, or PKPK).	MEAN	✓	
:FORMAT?	Query math format.		✓	
:DATA?	Read math result of CALC3.		✓	

* The format (ASCII, hexadecimal, octal, or binary) for the returned value is set by FORMAT:SOURCE2 <name>.

Table 18-2
DISPlay command summary

Command	Description	Default parameter	SCPI
:DISPlay			
:ENABLE 	Turn on or turn off front panel display.	(Note 1)	✓
:ENABLE?	Query state of display.		✓
:CNDisplay	Return to source-measure display state.		
[:WINDow[1]]	Path to locate message to top display:		✓
:TEXT	Control user test message:	(Note 2)	✓
:DATA <a>	Define ASCII message "a" (up to 20 characters).		✓
:DATA?	Query text message.		✓
:STATE 	Enable or disable message mode.	(Note 3)	✓
:STATE?	Query text message state.		✓
:DATA?	Query data on top portion of display.		
:ATTRIBUTES?	Query attributes of message characters: blinking (1) or not blinking (0).		
:WINDow2	Path to locate message to bottom display:		✓
:TEXT	Control user test message:	(Note 2)	✓
:DATA <a>	Define ASCII message "a" (up to 32 characters).		✓
:DATA?	Query text message.		✓
:STATE 	Enable or disable message mode.	(Note 3)	✓
:STATE?	Query text message state.		✓
:DATA?	Query data on bottom portion of display.		
:ATTRIBUTES?	Query attributes of message characters: blinking (1) or not blinking (0).		
:DIGits <n>	Specify display resolution (4 to 7).	6	
:DIGits?	Query display resolution		

Notes:

1. *RST and :SYSTEM:PRESet has no effect on the display circuitry. Pressing LOCAL or cycling power enables (ON) the display circuit.
2. *RST and :SYSTEM:PRESet has no effect on a user-defined message. Pressing LOCAL or cycling power cancels all user-defined messages.
3. *RST and :SYSTEM:PRESet has no effect on the state of the message mode. Pressing LOCAL or cycling power disables (OFF) the message mode.

Table 18-3
FORMat command summary

Command	Description	Default parameter	SCPI
:FORMat			
:SREGister <name>	Select data format for reading status event registers (ASCIi, HEXadecimal, OCTal or BINary).	ASCIi	✓
:SREGister?	Query format for reading status event registers.		
[:DATA] <type>[<,length>]	Specify data format (ASCIi, REAL, 32 or SREal).	ASCIi	✓
[:DATA]?	Query data format.		✓
:BORDER <name>	Specify byte order (NORMal or SWAPped).	(Note)	✓
:BORDER?	Query byte order.		✓
:ELEMENTs			
[:SENSe[1]] <item list>	Specify data elements (VOLTage, CURRent, RESistance, TIME, and STATus).	All	
[:SENSe[1]]?	Query data format elements.		
:CALCulate <item list>	Specify CALC data elements (CALC, TIME, or STATus).	CALC	
:CALCulate?	Query CALC data elements.		
:SOURce2 <name>	Specify SOURce2 data format (ASCIi, HEXadecimal, OCTal, or BIN).	ASCIi	
:SOURce2?	Query SOURce2 data format.		

Note: Byte order — *RST default is NORMal. :SYSTEM:PRESet default is SWAPped.

Table 18-4
OUTPut command summary

Command	Description	Default parameter	SCPI	Source memory
:OUTPut[1]			✓	
:STATe 	Turn source on or off.	OFF	✓	
:STATe?	Query state of source.		✓	
:ENABLE	Path to control output enable:			
[:STATE] 	Enable or disable output enable.	OFF		
[:STATE]?	Query state of output enable.			
:TRIPped?	Output enable tripped?: 1 (no) or 0 (yes)			
:SMODE <name>	Select output off mode (HIMPedance, NORMal, ZERO or GUARd). ¹	NORMal ²		✓
:SMODE?	Query output off mode.			

1. For the Model 2430 Pulse Mode, the output off mode is always NORMal. This command is invalid (error +831).

2. For the Model 2410, default is GUARd.

Table 18-5

ROUTE command summary

Command	Description	Default parameter	SCPI	Source memory
:ROUTE :TERMinals <name> :TERMinals?	Select in/out terminals: (FRONT or REAR). Query in/out terminals.	FRONT	✓	✓

Table 18-6
SENSe command summary

Command	Description	Default parameter	SCPI	Source memory
[:SENSe[1]]	Sense 1 Subsystem:		✓	
:DATA	Path to SENSe[1] data.		✓	
[:LATest?]	Return only most recent reading.			
:FUNCTION	Select measurement function(s):		✓	
:CONCurent 	Enable or disable ability to measure more than one function simultaneously. When disabled, volts function is enabled. ¹	ON	✓	✓
:CONCurent?	Query concurrent state.		✓	
[:ON] <function list>	Specify functions to enable (VOLTage[:DC], CURRent[:DC], or RESistance).	CURRent	✓	✓
:ALL	Enable all functions (concurrent enabled) or enable ohms function (concurrent disabled). ¹		✓	
:COUNT?	Query number of functions that are enabled.		✓	
[:ON]?	Returns list of functions that are enabled.		✓	
:OFF <function list>	Specify functions to disable: (VOLTage[:DC], CURRent[:DC], or RESistance).	VOLTage, RESistance	✓	✓
:ALL	Disable all measurement functions.		✓	
:COUNT?	Query number of functions that are disabled.		✓	
:OFF?	Returns list of functions that are disabled.		✓	
:STATE? <name>	Query state of specified function: 1 (on) or 0 (off).		✓	

1. For the Model 2430 Pulse Mode, concurrent measurements are always disabled. This command is invalid (error +831).

Table 18-6 (continued)

SENSE command summary

Command	Description	Default parameter	SCPI	Source memory
[[:SENSE[1]]				
:CURRENT[:DC]	Path to configure current:		✓	
:RANGE	Configure measurement range:		✓	
[:UPPer]	Select range by specifying the expected current reading. ¹	1.05e-4	✓	✓ ⁴
<n> UP DOWN				
[:UPPer]?	Query range.		✓	
:AUTO 	Enable or disable auto range. ²	ON	✓	✓ ⁴
:AUTO?	Query auto range.		✓	
:ULIMit?	Returns I compliance range.		✓	
:LLIMit <n>	Set auto ranging lower limit (-105e-6 to 105e-6).	1e-6	✓	
:LLIMit?	Query auto ranging lower limit.		✓	
:NPLCycles <n>	Specify integration rate (in line cycles): 0.01 to 10. ³	1.0	✓	✓ ⁴
:NPLCycles?	Query integration rate.		✓	
:PROTection	Path to configure current compliance:		✓	
[:LEVel] <n>	Specify current limit for V-Source. ¹	1.05e-4	✓	✓ ⁴
[:LEVel]?	Query current compliance limit.		✓	
:TRIPped?	In current compliance: 1 (yes), 0 (no).		✓	
:RSYNchronize 	Enable or disable measure and compliance range synchronization.	OFF		
:RSYNchronize?	Query range synchronization.			
:VOLTage[:DC]	Path to configure volts:		✓	
:RANGE	Configure measurement range:		✓	
[:UPPer]	Select range by specifying the expected voltage reading. ¹	21	✓	✓ ⁵
<n> UP DOWN				
[:UPPer]?	Query range.		✓	
:AUTO 	Enable or disable auto range. ²	ON	✓	✓ ⁵
:AUTO?	Query auto range.		✓	
:ULIMit?	Returns V compliance range.		✓	
:LLIMit <n>	Set auto range lower limit. ¹	0.21	✓	
:LLIMit?	Query auto range lower limit.		✓	
:NPLCycles <n>	Specify integration rate (in line cycles): 0.01 to 10. ³	1.0	✓	✓ ⁵
:NPLCycles?	Query integration rate.		✓	
:PROTection	Path to configure voltage compliance:		✓	
[:LEVel] <n>	Specify voltage limit for I-Source. ¹	21	✓	✓ ⁵

1. The parameter values for this command are provided with the detailed command reference information. Detailed information on SCPI commands follows the last command summary table in this section.

2. For the Model 2430 Pulse Mode, auto range is invalid (error +831).

3. For the Model 2430 Pulse Mode, <n> = 0.004 to 0.100.

4. If source V is active.

5. If source I is active and auto ohms is disabled.

6.

Table 18-6 (continued)
SENSe command summary

Command	Description	Default parameter	SCPI	Source memory
[[:SENSe[1]]				
:VOLTage[:DC]				
:PROTection				
[:LEVel]?	Query voltage compliance limit.		✓	
:TRIPped?	In voltage compliance?: 1 (yes), 0 (no).		✓	
:RSYNchronize 	Enable or disable measure and compliance range synchronization.	OFF		
:RSYNchronize?	Query range synchronization.			
:RESistance	Path to configure resistance:		✓	
:MODE <name>	Select ohms mode (MANual or AUTO).	AUTO		✓
:MODE?	Query ohms mode.			
:OCOMpensated 	Enable or disable offset-compensated ohms. ¹	OFF	✓	✓
:OCOMpensated?	Query state of offset-compensated ohms.		✓	
:RANGe	Configure measurement range:		✓	
[:UPPer]	Select range by specifying the expected resistance reading. ²	2.1e5	✓	✓
<n> UP DOWN				
[:UPPer]?	Query range.		✓	
:AUTO 	Enable or disable auto range. ³	ON	✓	✓
:AUTO?	Query auto range.		✓	
ULIMit <n>	Set auto range upper limit. ²		✓	
ULIMit?	Query auto range upper limit.		✓	
LLIMit <n>	Set auto range lower limit. ²		✓	
LLIMit?	Query auto range lower limit.		✓	
:HOLDoff 	Enable/disable current range holdoff for source memory sweeps.			✓
:HOLDoff?	Query current range holdoff state.			
:DELay <NRf>	Set holdoff delay (sec.): 0 to 999.9999.			✓
:DELay?	Query holdoff delay.			
:NPLCycles <n>	Specify integration rate (in line cycles): 0.01 to 10. ⁴	1.0	✓	✓
:NPLCycles?	Query integration rate.		✓	

1. For the Model 2430 Pulse Mode, offset-compensated ohms cannot be enabled using this command. This command is invalid (error +831).

2. The parameter values for this command are provided with the detailed command reference information. Detailed information on SCPI commands follows the last command summary table in this section.

3. For the Model 2430 Pulse Mode, auto range is invalid (error +831).

4. For the Model 2430 Pulse Mode, <n> = 0.004 to 0.100.

Table 18-6 (continued)

SENSE command summary

Command	Description	Default parameter	SCPI	Source memory
[:SENSe[1]] :VOLTage[:DC] :AVERage :TCONtrol <name> :TCONtrol? :COUNT <n> :COUNT? [:STATe] [:STATe]?	Path to configure and control digital filter: Specify filter type (MOVing or REPeat). ¹ Query filter type. Specify filter count (1 to 100). ¹ Query filter count. Enable or disable filter. ² Query state of filter.	REPeat 10 OFF	✓ ✓ ✓ ✓ ✓ ✓	✓ ✓ ✓

1. For the Model 2430 Pulse Mode, filtering is not used. This command is ignored.

2. For the Model 2430 Pulse Mode, the filter cannot be enabled. This command is invalid (error +831).

Table 18-7
SOURce command summary

Command	Description	Default parameter	SCPI	Source memory
[:SOURce[1]]	Path to control sourcing:		✓	
:CLEar	Path to clear source:			
[:IMMEdiate]	Turn selected source off.			
:AUTO 	Enable or disable auto clear for source. ¹			
:AUTO?	Query state of auto clear.	OFF		
:MODE <name>	Specify auto clear mode (ALWays or TCOunt).	ALWays		
:MODE?	Query auto clear mode.			
:FUNCTion	Source selection:		✓	
:SHAPE <name>	Model 2430 Only — Select output mode (DC or PULSE).	DC		✓
:SHAPE?	Query output mode.			
[:MODE] <name>	Select source mode (VOLTage, CURRent or MEMory).	VOLTage	✓	✓
[:MODE]?	Query source selection		✓	
:DELay <n>	Specify settling time (in sec): 0 to 9999.999. ²	0		✓
:AUTO 	Enable or disable auto settling time. ²	ON		✓
:AUTO?	Query state of auto settling time.			
:DELay?	Query source settling time.			
:CURRent	Path to configure I-Source:		✓	
:MODE <n>	Select I-Source mode (FIXed, SWEep, or LIST).	FIXed	✓	
:MODE?	Query I-Source mode.		✓	
:RANGE <n>[UP DOWN]	Select fixed I-Source range. ³	1.05e-4	✓	✓ ⁴
:AUTO 	Enable or disable autoranging.	ON	✓	
:AUTO?	Query state of autoranging.		✓	
:RANGE?	Query I-Source range setting.		✓	
[:LEVel]	Set I-Source level (in amps):		✓	
[:IMMEdiate]	Set level immediately:		✓	
[:AMPLitude] <n>	Specify current level. ³	0	✓	✓ ⁴
[:AMPLitude]?	Query current level.		✓	

1. For the Model 2430 Pulse Mode, auto clear is always enabled. This command is ignored.

2. For the Model 2430 Pulse Mode, source delay is not used. This command is ignored.

3. The parameter values for this command are provided with the detailed command reference information. Detailed information on SCPI commands follows the last command summary table in this section.

4. If source V is active.

Table 18-7 (continued)
SOURce command summary

Command	Description	Default parameter	SCPI	Source memory
<code>[:SOURce[1]]</code>				
<code>:VOLTag</code>				
<code>[:LEVel]</code>	Set V-Source level (in volts):		✓	
<code>[:IMMediate]</code>	Set specified level immediately:		✓	
<code>[:AMPLitude] <n></code>	Specify voltage level. ¹	0	✓	✓ ³
<code>[:AMPLitude]?</code>	Query voltage level.		✓	
<code>:TRIGgered</code>	Set specified level when triggered:		✓	
<code>[:AMPLitude] <n></code>	Specify voltage level. ¹	0	✓	
<code>[:AMPLitude]?</code>	Query voltage level.		✓	
<code>:SFACtor <n></code>	Set voltage scaling factor (-999.9999e+18 to +999.9999e+18).	0		✓ ³
<code>:STATe </code>	Enable/disable voltage scaling factor.	OFF		✓ ³
<code>:STATe?</code>	Query voltage scaling factor state.			
<code>:SFACtor?</code>	Query voltage scaling factor.			
<code>:PROTection</code>	Path to limit output voltage:		✓	
<code>[:LEVel] <NRf></code>	Specify voltage limit level. ¹	(Note 2)	✓	
<code>[:LEVel]?</code>	Query voltage limit.		✓	
<code>:TRIPped?</code>	Voltage limit detected: 1 (yes), 0 (no).		✓	
<code>:STARt <n></code>	Specify start level for V-sweep. ¹	0	✓	
<code>:STARt?</code>	Query start level for voltage sweep.		✓	
<code>:STOP <n></code>	Specify stop level for V-sweep. ¹	0	✓	
<code>:STOP?</code>	Query stop level for voltage sweep.		✓	
<code>:STEP <n></code>	Specify step value for V-sweep. ¹	0		
<code>:STEP?</code>	Query step value for voltage sweep.			
<code>:SPAN <n></code>	Specify span. ¹	0	✓	
<code>:SPAN?</code>	Query span.		✓	
<code>:CENTer <n></code>	Specify center point. ¹	0	✓	
<code>:CENTer?</code>	Query center point.		✓	
<code>:SOAK <NRf></code>	Set first sweep point soak time (0.00000 to 9999.999s).	0.00000	✓	
<code>:SOAK?</code>	Query soak time.		✓	

1. The parameter values for this command are provided with the detailed command reference information. Detailed information on SCPI commands follows the last command summary table in this section.
2. SYSTem:PRESet default is 40, *RST default is NONE.
3. If source V is active.

Table 18-7 (continued)

SOURce command summary

Command	Description	Default parameter	SCPI	Source memory
[[:SOURce[1]]				
:SWEep	Configure SWEep source mode:		✓	
:SPACing <name>	Select sweep spacing type (LINear or LOGarithmic).	LINear	✓	
:SPACing?	Query sweep spacing.		✓	
:POINts <n>	Specify number of sweep points (2 to 2500).	2500	✓	
:POINts?	Query number of points in sweep.		✓	
:DIRectioN <name>	Sweep from start to stop (UP) or from stop to start (DOWN).	UP		
:DIRectioN?	Query sweep direction.			
:RANGing <name>	Select source ranging mode (BEST, AUTO, or FIXed).	BEST	✓	
:RANGing?	Query source ranging mode.		✓	
:CABort <name>	Abort on compliance (NEVer, EARLy, or LATE).	NEVer		
:CABort?	Query abort on compliance state.			
:LIST	Configure LIST source mode:		✓	
:CURRent <NRf>	Create list of I-Source values. ¹			
:APPend <NRf>	Add I-Source values to end of list.		✓	
:POINts?	Query number of source values in list.			
:STARt <n>	Specify list sweep start point.	1		
:STARt?	Query list sweep start point.			
:CURRent?	Query I-Source list.		✓	
:VOLTage <NRf>	Create list of V-Source values.	1		
:APPend <NRf>	Add V-Source values to end of list.			
:POINts?	Query number of source values in list.			
:STARt <n>	Specify list sweep start point.	1		
:STARt?	Query list sweep start point.			
:VOLTage?	Query V-Source list.			
:MEMory	Configure Source Memory Sweep:			
:SAVE <n>	Save settings at memory location (1 to 100).			
:RECall <n>	Recall settings from memory (1 to 100).	1		
:POINts <n>	Specify number of sweep points (1 to 100).			
:POINts?	Query number of sweep points.			
:STARt <NRf>	Specify start location for Source Memory Sweep (1 to 100).	1		
:STARt?	Query start location.			

1. The parameter values for this command are provided with the detailed command reference information. Detailed information on SCPI commands follows the last command summary table in this section.

Table 18-7 (continued)

SOURce command summary

Command	Description	Default parameter	SCPI	Source memory
[:SOURce[1]] :PULSe	Model 2430 — Configure pulse for Pulse Mode:		✓	
:WIDTh <n>	Set pulse width (0.00015 to 0.005 sec).		✓	✓
:WIDTh?	Query pulse width.		✓	
:DELay <n>	Set pulse delay (0 to 9999.999 sec).		✓	✓
:DELay?	Query pulse delay.		✓	
:SOURce2	Path to control digital output lines:			
:BSIZe <n>	Set Digital I/O bit size (3 or 4). ¹	4		
:BSIZe?	Query Digital I/O bit size.			
:TTL				
[:LEVel] [:DEFault] <NRf>, <NDN>	Specify digital output pattern. ²	15		
[:LEVel] [:DEFault]?	Query default output pattern. ³			
:ACTual?	Read actual output pattern.			
:TTL4				
:MODE <name>	Set Digital I/O mode (EOTest or BUSY).	EOTest		
:MODE?	Query Digital I/O line 4 mode.			
:BSTate 	Set BUSY and EOT polarity (HI or LO).	LO		
:BSTate?	Query BUSY and EOT polarity.			
:CLEar	Clear digital output:			
[:IMMediate]	Restore (clear) to :TTL output pattern.			
:AUTO 	Enable or disable auto-clear.	OFF		
:AUTO?	Query state of auto-clear.			
:DELay <n>	Specify pulse-width of pass/fail pattern (0.0000 to 60 sec).	0.00001		
:DELay?	Query delay.			

1. 16 with 2499-DIGIO 16-bit option.

2. Bit range set by :BSIZe.

3. Format set by FORMat:SOURce2 <name>.

Table 18-8
STATus command summary

Command	Description	Default parameter	SCPI
:STATus		(Note 1)	✓
:MEASurement	Control measurement event registers:		
[:EVENT]?	Read the event register. ⁶	(Note 2)	✓
:ENABLE <NDN> or <NRf>	Program the enable register.	(Note 3)	✓
:ENABLE?	Read the enable register. ⁶		✓
:CONDition?	Read the condition register. ⁶		✓
:OPERation	Control operation status registers:		✓
[:EVENT]?	Read the event register. ⁶	(Note 2)	✓
:ENABLE <NDN> or <NRf>	Program the enable register.	(Note 3)	✓
:ENABLE?	Read the enable register. ⁶		✓
:CONDition?	Read the condition register. ⁶		✓
:QUESTionable	Control questionable status registers:		✓
[:EVENT]?	Read the event register. ⁶	(Note 2)	✓
:ENABLE <NDN> or <NRf>	Program the enable register.	(Note 3)	✓
:ENABLE?	Read the enable register. ⁶		✓
:CONDition?	Read the condition register. ⁶		✓
:PRESet	Return status registers to default states.		✓
:QUEue	Path to access error queue:		✓
[:NEXT]?	Read the most recent error message.	(Note 4)	✓
:ENABLE <list>	Specify error/status messages for error queue.	(Note 5)	✓
:ENABLE?	Read the enabled messages.		✓
:DISable <list>	Specify messages not to be placed in error queue.	(Note 5)	✓
:DISable?	Read the disabled messages.		✓
:CLEar	Clears all messages from error queue.		✓

Notes:

1. Commands in this subsystem are not affected by *RST and :SYSTEM:PRESet. The effects of cycling power, *CLS and :STATus:PRESet, are explained by the following notes.
2. Event Registers — Power-up and *CLS clears all bits. :STATus:PRESet has no effect.
3. Enable Registers — Power-up and :STATus:PRESet clears all bits. *CLS has no effect. Accepts the SCPI 1995.0 mandated (non-decimal numeric) format (#H, #Q, or #B).
4. Error Queue — Power-up and *CLS clears all bits of the registers.
5. Error Queue Messages — Power-up clears list of messages. *CLS and :STATus:PRESet have no effect.
6. Register Query Commands — The format for the response messages (ASCII, hexadecimal, octal, or binary) depends on which data format is presently selected (see “Status register format,” page 18-54).

Table 18-9
SYSTem command summary

Command	Description	Default parameter	SCPI	Source memory
:SYSTem				
:PRESet	Return to :SYSTem:PRESet defaults.		✓	
:POSetup <name>	Select power-on setup (RST, PRESet or SAV 0-4).			
:POSetup?	Query power-on setup.			
:VERsion?	Query revision level of SCPI.		✓	
:ERRor	Path to read messages in error queue (Note 1).			
[:NEXT]?	Return and clear oldest error (code and message).		✓	
:ALL?	Return and clear all errors (codes and messages).			
:COUNT?	Return the number of errors.			
:CODE	Path to return error code numbers only:			
[:NEXT]?	Return and clear oldest error (code only).			
:ALL?	Return and clear all errors (codes only).			
:CCHeck 	Enable or disable contact check. Remote sensing must be enabled (:SYST:RSEN ON).			
:RES <Nrf>	Specify resistance threshold for contact check (50ohm default).			
:CLear	Clears messages from error queue.			
:RSENse 	Enable or disable remote sensing.	OFF		✓
:RSENse?	Query state of remote sensing.			
:KEY <n>	Simulate key-press (1 to 31). See Figure 18-3 .			
:KEY?	Query the last pressed key.		✓	
:GUARd <name>	Select guard type (OHMS or CABLe).	CABLe	✓	
:GUARd?	Query guard type.			
:BEEPer	Control beeper:			
[:IMMEDIATE]	Beep at specified frequency (65 to 2e6 Hz) for specified time period (0 to 7.9 seconds).			
<freq, time>				
:STATe 	Enable or disable beeper.	ON		
:STATe?	Query state of beeper.		✓	

1. Clearing Error Queue — Power-up and *CLS clears the error queue. *RST, :SYSTem:PRESet, and :STATus:PRESet have no effect.

Table 18-9 (continued)

SYSTem command summary

Command	Description	Default parameter	SCPI	Source memory
:SYSTem				
:AZERO	Control auto zero and NPLC caching.			✓
[:STATE] <name>	Control auto zero (OFF = disabled; ON = enabled; ONCE = force immediate update of auto zero.)	ON		✓
[:STATE]?	Query auto zero state.		✓	
:CACHing	Control NPLC caching.			
[:STATE]	Enable (ON or 1) or disable (OFF or 0) NPLC caching.	OFF		
[:STATE]?	Query NPLC caching state.			
:REFresh	Force an immediate update for all NPLC values in cache.			
:RESet	Clear the cache of all NPLC values.			
:NPLCycles?	Return a list of NPLC values in the cache from oldest to newest.			
:LFRrequency <freq>	Select line frequency: 50 or 60 (Hz):			
:AUTO 	Enable or disable auto frequency.	(Note 1)		
:AUTO?	Query state of auto frequency.			
:LFRrequency?	Query line frequency.			
:TIME	Timestamp:			
:RESet	Reset timestamp to zero seconds.			
:AUTO 	Enable/disable timestamp reset when exiting idle.	OFF		
:TIME?	Query timestamp.			
:MEMory	Initialize memory:			
:INITialize	Initialize battery backed RAM.		✓	
:LOCal	Take unit out of remote (RS-232 only).		✓	
:RWLock 	Enable or disable local lockout (RS-232 only).			
:RCMode <name>	Set auto range on compliance mode (SINGLE or MULTiple).	SINGLE		
:RCMode?	Query auto range on compliance mode.			
:MEP	Path to 488.1 protocol (Appendix G).			
[:STATE]?	Query protocol (1 = SCPI, 0 = 488.1).			
:HOLDoff 	Enable/disable NDAC hold-off.	OFF		

1. The auto line frequency setting is not affected by *RST and :SYSTem:PRESet.

Table 18-10
TRACe command summary

Command	Description	Default parameter	SCPI
:TRACe :DATA	Use :TRACe or :DATA as root command:	(Note)	✓
:DATA?	Read the contents of the buffer (data store).		✓
:CLEAr	Clear readings from buffer.		
:FREE?	Query bytes available and bytes in use.		✓
:POINts <NRf>	Specify size of buffer (1 to 2500).		✓
:ACTual?	Queries number of readings stored in the buffer.		
:POINts?	Query buffer size.		✓
:FEED <name>	Select source of readings (SENSE[1], CALCulate[1], or CALCulate2).		✓
:CONTrol <name>	Specify buffer control mode (NEVER or NEXT).		✓
:CONTrol?	Query buffer control mode.		✓
:TSTamp	Path to set timestamp format:		
:FORMat <name>	Select format (ABSolute or DELTa).		
:FORMat?	Query timestamp format.		

Note: :SYSTEM:PRESet and *RST have no effect on the commands in this subsystem.

Table 18-11
TRIGger command summary

Command	Description	Default parameter	SCPI
:INITiate[:IMMediate]	Initiate source-measure cycle(s).		✓
:ABORt	Reset trigger system. Goes to idle state.		✓
:ARM	Path to program Arm Layer:		✓
[:SEQuence[1]]			✓
[:LAYer[1]]			✓
:COUNT <n>	Specify arm count (1 to 2500 or INFinite).	1	✓
:COUNT?	Query arm count (INFinite = +9.9e37).		✓
:SOURce <name>	Specify control source (IMMediate, TIMer, MANual, BUS, TLINK, NSTest, PSTest, or BSTest).	IMMediate	✓
:SOURce?	Query control source.		✓
:TIMer <n>	Set timer interval in seconds (0.001 to 99999.99).	0.1	✓
:TIMer?	Query timer interval.		✓
[:TCONfigure]			✓
:DIRection <name>	Enable (SOURce) or disable (ACCeptor) bypass.	ACCeptor	✓
:DIRection?	Query state of bypass.		✓
[:ASYNchronous]	Configure output triggers:		✓
:ILINe <n>	Select input trigger line (1, 2, 3, or 4).	1	
:ILINe?	Query input trigger line.		
:OLINe <n>	Select output trigger line (1, 2, 3, or 4).	2	
:OLINe?	Query output trigger line.		
:OUTPut <name>	Output trigger (TENTer, TEXit, or NONE).	NONE	
:OUTPut?	Query arm output trigger status.		
:TRIGger	Path to program Trigger Layer:		✓
:CLEar	Clear any pending input triggers immediately.		✓
[:SEQuence[1]]			✓
:COUNT <n>	Specify trigger count (1 to 2500).	1	✓
:COUNT?	Query trigger count.		✓
:DELAy <n>	Specify trigger delay: 0 to 999.9999 (sec). ¹	0	✓
:DELAy?	Query source delay.		✓
:SOURce <name>	Specify control source (IMMediate or TLINK).	IMMediate	✓
:SOURce?	Query control source.		✓

1. For the Model 2430 Pulse Mode, trigger delay is not used. This command is ignored.

Table 18-11 (continued)

TRIGger command summary

Command	Description	Default parameter	SCPI
:TRIGger			
[:SEQuence[1]]			
[:TCONfigure]			✓
:DIRection <name>	Enable (SOURce) or disable (ACCeptor) bypass.		✓
:DIRection	Query state of bypass.		✓
[:ASYNchronous]	Configure output triggers:		✓
:ILINE <n>	Select input trigger line (1, 2, 3, or 4).	1	
:ILINE?	Query input trigger line.		
:INPut <event list>	Enable input event detectors (SOURce, DELay, SENSE, or NONE).	NONE	
:INPut?	Query enabled input event detectors.		
:OLINE <n>	Select output trigger line (1, 2, 3, or 4).	2	
:OLINE?	Query output trigger line.		
:OUTPut <event list>	Output trigger after SOURce, DELay, SENSE or not (NONE) at all.	NONE	
:OUTPut?	Query when output trigger is going to occur.		

exist can be listed using the :CATalog? command. The actual math expression can be read using the :MATH? command. The built-in math expressions (except POWER) require a two-point sweep in order to perform the calculation. The “Program fragments” show how to configure the SourceMeter for these math expressions.

When you want to create a new user-defined math expression, perform the following steps in order:

1. If desired, assign units to the calculation result. (See “:UNITs <name>,” page 18-28.) Units is stored for the calculation.
2. Assign a name to the expression (using up to 10 ASCII characters) using this command.
3. Define the expression using the: DEFine or EXPReSSion command. The new expression is the one that will be presently selected.

Math expression errors:

- +801 “Insufficient vector data” — Returned to idle before acquiring enough data to fully populate the vector. A CALC1 result is not built.
- +804 “Expression list full” — Attempted to create a new expression name when the list (catalog) is full. The maximum number of user-defined expression names is five.
- +805 “Undefined expression exists” — Attempted to create a new expression name while a previous expression name remains undefined. Remember, after creating a name, you have to define the expression.
- +806 “Expression not found” — Attempted to delete a named math expression that cannot be found.
- +807 “Definition not allowed” — Attempted to define an expression that has not been previously named.
- +808 “Expression cannot be deleted” — Attempted to delete one of the built-in math expressions. (See “:DELete[:SELected] <name>,” page 18-28.)
- +809 “Source memory location revised” — Occurs when a :SOURce:MEMory sweep location references an expression that no longer exists.
- +811 “Not an operator or number” — Defined a null math expression by not using a valid operator or number.
- +812 “Mismatched parenthesis” — Number of open parentheses must be the same as the number of closed parentheses. For example, CALC1:MATH:EXPR (2*sin(VOLT) generates this error.
- +813 “Not a number of data handle” — An invalid floating point number or symbol other than VOLT, CURR, RES, or TIME appears in the math expression.
- +814 “Mismatched brackets” — Improper use of brackets for vectored math expression indices. For example, CALC1:MATH:EXPR (VOLT[0]*CURR[0]) generates this error.
- +815 “Too many parenthesis” — Too many closed parentheses were detected. For example, CALC1:MATH:EXPR (ln(VOLT)) generates this error.
- +816 “Entire expression not parsed” — Occurs when the input expression does not produce a function for the SourceMeter to calculate.
- +817 “Unknown token” — Attempted to define an expression using an invalid function name.
- +818 “Error parsing mantissa” — Occurs when a floating point number has an invalid mantissa.

- +819 "Error parsing exponent" — Occurs when a floating point number has an invalid exponent.
- +820 "Error parsing value" — Occurs when an invalid floating point number is entered.
- +821 "Invalid data handle index" — An invalid array index value was assigned to a vectored expression. Array indices start at 0 and can be as high as 2499.

Notes:

- Up to five user-defined math expressions can be created.
- A selected math expression can only be performed if CALC1 is enabled. (See "[:STATe ."]")
- When the math expression is vectored, the math result will not be generated until all source-measure operations for the vector array are performed.
- Initializing memory (:SYSTEM:MEMORY:INITIALize) deletes all user-defined math expressions and selects the POWER expression.

:DELeTe[:SELeCted] <name>

:CALCulate[1]:MATH[:EXPRession]:DELeTe[:SELeCted] <name> Delete user-defined math expression

Parameters <name> = "user-name" Name of user-defined math expression

Description This command is used to remove (delete) the specified user-defined math expression from the catalog. Once removed, that math expression can no longer be selected. You can use the :CATalog? command to verify that the math expression is gone.

For example, if you wish to delete a user-defined math expression that is named "math1," you would send the following command:

```
:DELeTe "math1"
```

You cannot delete built-in math expressions. This will result in error +808, "Expression cannot be deleted."

:DELeTe:ALL

:CALCulate[1]:MATH[:EXPRession]:DELeTe:ALL Delete all user-defined math expression

Description This action command will remove (delete) all user-defined math expressions from the catalog. Built-in math expressions are not affected.

Assign unit suffix

:UNITs <name>

:CALCulate[1]:MATH:UNITs <name> Specify units for user-defined calculation

Parameters <name> = Three ASCII characters enclosed in single or double quotes

Query	:UNITS?	Query units for user-defined calculation
Description	<p>This command is used to specify the units suffix name for a user-defined math calculation. Use three ASCII characters for the units suffix name. If using fewer than three characters, add spaces to the right of the units name in the string. For example, if the units name is "Z," send it as follows:</p> <pre>:calc:math:unit "Z "</pre> <p>The units name can also be enclosed in single quotes as follows:</p> <pre>:calc:math:unit 'Z'</pre>	

Define math expression

[:EXPRession] <form> or [:DEFine] <form>

:CALCulate[1]:MATH[:EXPRession] <form> Define math formula
 :CALCulate[1]:MATH[:EXPRession][:DEFine] <form> Define math formula

Parameters <form> = mathematical formula using instrument readings, numbers and standard math operator symbols. See "Description" for details.

Query :MATH? Query user-defined math expression

Description Use either of these two commands to define a math formula using measure and source readings, numeric constants, and standard math operator symbols. After the math expression is defined, it will be assigned to the name that was created using the :NAME command and will become the selected math expression. See "[NAME <name>](#)," [page 18-26](#) for more details.

Valid parameter names for measure and source readings include:

VOLTage	Use V-Measure or V-Source reading
CURRent	Use I-Measure or I-Source reading
RESistance	Use ohms reading
TIME	Use timestamp reading

Valid math operators and their operations are listed as follows:

+	Add
-	Subtract
*	Multiply
/	Divide
^	Exponent
log	Logarithmic, base 10
ln	Natural log
sin	Sine
cos	Cosine
tan	Tangent
exp	e ^x

NOTE The log and ln operations are performed on the absolute value of the specified number. For example, log (100) = 2 and log (-100) = 2.

Expressions are evaluated according to the following precedence rules:

1. Enclosed by parentheses
2. Unary operators (+ and -)
3. ^ (exponentiation)
4. * (multiplication) and / (division)
5. + (addition) and - (subtraction)
6. Left to right.

The readings used for the calculation depend on how the SourceMeter is configured. If configured to Source V Measure I, the voltage reading for the calculation will be the source value, and the current reading will be the current measurement. Conversely, if configured to Source I Measure V, the current reading will be the source value, and the voltage reading will be the voltage measurement.

Measure readings take priority over source readings. Thus, if configured to Source V Measure V, the voltage reading for the calculation will be the voltage measurement (not the programmed V-Source value). Conversely, if configured to Source I Measure I, the current reading for the calculation will be the current measurement.

The result of a calculation using a reading that is not sourced or measured will be the invalid NAN (not a number) value of +9.91e37. For example, using a current reading in a calculation for Source V Measure V will cause a NAN result.

Example using Source I Measure V configuration:

```
:calc:math (volt * curr) Calculate power using voltage measurement  
and I-Source value.
```

After a calculation is configured and enabled, the results are displayed when source-measure operations are performed. (See “:STaTe ,” page 18-32.) Use the :data? command to send the results to the computer.

Vectored math

By incorporating vectors, you select which readings to use for the math calculation. After all programmed source-measure operations are completed, the math calculation(s) are performed using readings indicated by the specified vectors.

Vector numbers are enclosed in brackets ([]), and start at 0. Thus, vector 0 is the first reading in the array, vector 1 is the second reading in the array, and so on. The largest vector number in the expression defines the vector array size.

For example, assume the SourceMeter is programmed to perform 10 source-measure operations, and the following vectored math calculation is used:

```
(volt[3] - volt[9])
```

The above expression defines a vector array that is made up of 10 readings. Since the SourceMeter is programmed to perform 10 source-measure operations, the calculation will yield one result every 10 SDM cycles. The fourth voltage reading (vector 3) and the 10th voltage reading (vector 9) are used for the calculation.

Now assume that the SourceMeter is configured to perform 20 source-measure operations. Since the vector size is still 10, two 10-reading arrays will be created. The calculation will now yield two results, one for each array.

The first result, as before, is based on the fourth and 10th readings of the first array. The second result is based on the 14th and 20th readings. These are the fourth (vector 3) and 10th (vector 9) readings of the second array.

Note that you need complete vector arrays to acquire valid calculation results. If, in the preceding example, the SourceMeter is changed to perform 25 source-measure operations, then the third array will be incomplete (first array is 10 readings, second array is 10 readings, third array is only 5 readings). After the SourceMeter goes back into idle, the "Insufficient vector data" error message will be displayed, and the third result will be NAN (+9.91e37).

To avoid incomplete vector arrays, make sure the programmed number of source-measure operations (arm count \times trigger count) is a multiple of the vector array size. In the preceding example, vector array size is 10. Thus, in order to avoid "Insufficient vector data" errors, the programmed number of source-measure operations has to be a multiple of 10 (10, 20, 30, 40, and so on).

The following vector math expression to calculate offset compensated ohms demonstrates proper syntax:

```
:calc:math ( (volt[1] - volt[0]) / (curr[1] - curr[0]) )
```

Notes:

1. Use nested parentheses to force math operations that are imbedded in the calculation (see example in ["Vectored math," page 18-30](#)).
2. A calculation expression can be up to 256 characters in length, including parentheses and white spaces.
3. When using the filter, the measured readings used in the calculation are filtered - NOT the result of the calculation.
4. For vector math, it is recommended that only the REPEAT filter be used. For the repeat filter, the calculations use only the filtered readings of the vector points. If you instead use the MOVING filter, each vector point will reflect the filtered average of all the previous readings in the vector array.
5. The data format (ASCII or binary) for calculation results is selected using the :FORMat:DATA? command. (See ["FORMat](#)

[subsystem,” page 18-47.](#)) The *RST and :SYSTEM:PRESet default is ASCII.

6. When brackets ([]) are left out of an expression, it is assumed that it is referencing the first vector point in the array (i.e., VOLT is the same as VOLT[0]).

Enable and read math expression result

:STATe

:CALCulate[1]:STATe

Control CALC1

Parameters	 =	0 or OFF 1 or ON	Disable CALC1 calculation Enable CALC1 calculation
-------------------	-------	---------------------	---

Query	:STATe?	Query state (on or off) of CALC1
--------------	---------	----------------------------------

Description This command is used to enable or disable the CALC1 calculation. When enabled, the selected math expression will be performed when the SourceMeter is triggered to perform the programmed source-measure operations.

After the SourceMeter returns to idle, you can read the result of the selected math expression using the :CALC1:DATA? command. (See next command.)

When disabled, the :CALC1:DATA? command will return the NAN (not a number) value of +9.91e37.

:DATA?

:CALCulate[1]:DATA?

Read CALC1 result

Description This query command is used to read the result of the CALC1 calculation. The largest valid calculation result can be $\pm 9.9e37$, which (defined by SCPI) is infinity.

For scalar math (non-vectorized math), this command is used to return calculation results for all the programmed source-measure points. For example, if 20 source-measure operations were performed, this command will return 20 calculation results.

For vector math, this command will only return the calculation results for the specified vector points.

An invalid NAN (not a number) result of +9.91e37 indicates that one of the following conditions exist:

- Error in the expression.
- The required measurement function is disabled.
- CALC1 is disabled. (See “:STATe ,” [page 18-32.](#))

NOTE See [Appendix C, “Data Flow,”](#) for a detailed explanation on how data flows through the various operation blocks of the SourceMeter. It clarifies the type of readings that are acquired by the various commands to read data.

:LATest?

:CALCulate[1]:DATA:LATest? Read latest CALC1 result

Description This command works exactly like CALC1:DATA? except that it returns only the latest CALC1 result.

CALCulate2

Configure and control limit tests

The following commands are used to configure and control the three limit tests for DUT. When used with a handler to provide binning operations, communication between the SourceMeter and the handler is provided via the Digital I/O port. Many control aspects of the digital output lines are performed from the SOURce2 Subsystem. These control aspects include setting and clearing the digital output lines, and setting pulse width. See “[SOURce2,](#)” [page 18-98,](#) subsystem for details.

NOTE The Model 2401 does not use the digital output lines of the Digital I/O port. Invalid CALCulate2 commands for the Model 2401 are listed in [Table 12-2.](#) They will cause undefined header errors.

Select input path

FEED <name>

:CALCulate2:FEED <name> Select input path for limit tests

Parameters	<name> =	CALCulate[1]	Use result of CALC1
		VOLTage	Use measured voltage reading
		CURRent	Use measured current reading
		RESistance	Use measured resistance reading

Query :FEED? Query input path for limit tests

Description This command is used to select the input path for the limit tests. With CALCulate[1] selected, the specified limits will be compared to the result of CALC1. With VOLTage selected, limits will be compared to the voltage measurement. With CURRent or RESistance selected, limits will be compared with the respective current or resistance measurement.

Null feed reading

OFFSet <n>

:CALCulate2:NULL:OFFSet <n> Specify null offset (REL) for feed

Parameters <n> = -9.999999e20 to 9.999999e20 Specify null offset value

Query :OFFSet? Query null offset value

Description This command lets you establish a null offset (REL) for the selected feed. When Null Offset is enabled the result is the algebraic difference between the feed reading and the offset value:
 CALC2 reading = feed reading - null offset

ACQUIRE

:CALCulate2:NULL:ACQUIRE Automatically acquire REL value

Description This command automatically acquires the null offset value. If no reading is available, then the next available reading will become the null offset value.

STATe

:CALCulate2:NULL:STATe Control null offset

Parameters = 1 or ON Enable null offset
 0 or OFF Disable null offset

Query :STATe? Query state of null offset

Description This command is used to enable or disable null offset. When enabled, the CALC2 reading will include the null offset value. (See [“OFFSet <n>,” page 18-34](#)) When disabled, CALC2 will not include the null offset.

Read CALC2

DATA?

:CALCulate2:DATA? Read CALC2

Description This command is used to acquire all the readings used for the CALC2 limit tests. Note that if null offset is enabled, then the CALC2 readings will include the null offset value. (See [“Null feed reading,” page 18-34](#).)
 At least one of the limit tests have to be enabled to acquire limit test readings. (See [“Configure and control limit tests,” page 18-35](#), and [“:STATe ,” page 18-32](#).)

NOTE See [Appendix C, "Data Flow,"](#) for a detailed explanation on how data flows through the various operation blocks of the SourceMeter. It clarifies the type of readings that are acquired by the various commands to read data.

LATest?

:CALCulate2:DATA:LATest?

Read latest CALC2 data

Description This command works exactly like CALC2:DATA, except it returns only the latest null offset or limit result.

Configure and control limit tests

COMPLIance:FAIL <name>

:CALCulate2:LIMit[1]:COMPLIance:FAIL <name>

Parameters <name> = IN Fail Limit 1 test when unit goes into compliance
OUT Fail Limit 1 test when unit comes out of compliance

Query :FAIL? Query when Limit 1 test failure occurs

Description This command is used to specify the condition that will cause Limit 1 test to fail. With IN specified, the test will fail when the SourceMeter goes into compliance. With OUT specified, the test will fail when the SourceMeter comes out of compliance.

[:DATA] <n>

:CALCulate2:LIMitx:LOWer[:DATA] <n>

Specify lower LIMIT x (x = 2, 3, 5-12)

:CALCulate2:LIMitx:UPPer[:DATA] <n>

Specify upper LIMIT x (x = 2, 3, 5-12)

Parameters <n> = -9.999999e20 to 9.999999e20 Specify limit value
DEFault Set specified lower limit to -1
Set specified upper limit to 1
MINimum Set specified limit to -9.999999e20
MAXimum Set specified limit to +9.999999e20

Query :UPPer? Query specified upper limit
:UPPer? DEFault Query *RST default upper limit
:UPPer? MINimum Query lowest allowable upper limit
:UPPer? MAXimum Query largest allowable upper limit
:LOWer? Query specified lower limit
:LOWer? DEFault Query *RST default lower limit
:LOWer? MINimum Query lowest allowable lower limit
:LOWer? MAXimum Query largest allowable lower limit

Description These commands are used to set the upper and lower limits for LIMIT 2, LIMIT 3, and LIMIT 5 through LIMIT 12 tests. The actual limit depends on which measurement function is currently selected. For example, a limit value of 1 μ is 1 μ A for the amps function and 1 μ V for the volts function. A limit value is not range sensitive. A limit of 2 for volts is 2V on all measurement ranges.

SOURce2 <NRf> |<NDN>

:CALCulate2:LIMit[1]:COMpliance:SOURce2 <NRf> |<NDN> Specify pattern; LIMIT 1 failure
 :CALCulate2:LIMitx:LOWer:SOURce2 <NRf>|<NDN> Specify pattern for grading mode;
 lower LIMIT x failure (x = 2, 3, 5-12)
 :CALCulate2:LIMitx:UPPer:SOURce2 <NRf>|<NDN> Specify pattern for grading mode;
 upper LIMIT x failure (x = 2, 3, 5-12)

NOTE *The above commands to set failure patterns for compliance and limits are invalid for the Model 2401 and will cause undefined header errors.*

Parameters	<NRf> =	0 to 7 (3-bit)	Decimal value
		0 to 15 (4-bit)	Decimal value
	<NDN> =	0 to #b111 (3-bit)	Binary value
		0 to #b1111 (4-bit)	Binary value
		0 to #q7 (3-bit)	Octal value
		0 to #q17 (4-bit)	Octal value
		0 to #h7 (3-bit)	Hexadecimal value
		0 to #hF (4-bit)	Hexadecimal value

Query :SOURce2? Query source value for specified limit

Description These commands are used to define the digital output fail patterns for the specified tests (0 to 7, 3-bit; 0 to 15, 4-bit). Note that the fail patterns for Limits 2, 3, 5-12 apply only to the grading mode.

Tests are performed in the following order:

1. Limit Test 4 (contact option only; see [Appendix F](#)).
2. Limit Test 1
3. Limit Test 2
 - a. Lower Limit 2
 - b. Upper Limit 2
4. Limit Test x, where x = 3, 5-12 in ascending numerical order.
 - a. Lower Limit x
 - b. Upper Limit x

The first failure in the test sequence determines the bit pattern for the digital output port. Subsequent failures in the test sequence will not change the defined digital output pattern. Note that the output value can be specified as a binary, octal, decimal, or hexadecimal value.

Use the following table to determine the parameter value for the desired decimal digital output pattern. For non-decimal parameters,

convert the decimal value to its binary, octal, or hexadecimal equivalent.

OUT 4*	OUT 3	OUT 2	OUT 1	Decimal value*
L	L	L	L	0
L	L	L	H	1
L	L	H	L	2
L	L	H	H	3
L	H	L	L	4
L	H	L	H	5
L	H	H	L	6
L	H	H	H	7
H	L	L	L	8
H	L	L	H	9
H	L	H	L	10
H	L	H	H	11
H	H	L	L	12
H	H	L	H	13
H	H	H	L	14
H	H	H	H	15

L = Low (Gnd)

H = High (>+3V)

* OUT 4 not used in 3-bit mode (values = 0 to 7)

The SourceMeter can be configured to place the defined fail bit pattern on the digital output immediately when a fail condition occurs, or it can wait until all testing on a device package is completed (operation leaves trigger layer). See [“Composite testing,” page 18-39](#) and [“BControl <name>,” page 18-41](#), for details

PASS:SOURce2 <Nrf> | <NDN>

:CALCulate2:LIMitx:PASS:SOURce2 <Nrf> | <NDN> Set sorting mode pass pattern (x = 2, 3, 5-12)

NOTE The above command to set the pass pattern for the sorting mode is invalid for the Model 2401 and will cause an undefined header error.

Parameters	<Nrf> =	0 to 7 (3-bit)	Decimal value
		0 to 15 (4-bit)	Decimal value
	<NDN> =	0 to #b111 (3-bit)	Binary value
		0 to #b1111 (4-bit)	Binary value
		0 to #q7 (3-bit)	Octal value
		0 to #q17 (4-bit)	Octal value
		0 to #h7 (3-bit)	Hexadecimal value
		0 to #hF (4-bit)	Hexadecimal value

Query :SOURce2? Query programmed source value

Description This command is used to define the 3-bit or 4-bit output pattern for the Digital I/O Port when a test (limit 2, 3, 5-12) for the sorting mode passes. Note that the output value can be specified in binary, octal, decimal, or hexadecimal format. Use the table provided in the "Description" for the :SOURce command to determine the parameter value for the desired decimal digital output pattern.

**STATe **

:CALCulate2:LIMit[1]:STATe Control LIMIT 1 test
 :CALCulate2:LIMitx:STATe Control LIMIT x test (x = 2, 3, 5-12)

Parameters	 =	1 or ON	Enable specified limit test
		0 or OFF	Disable specified limit test

Query :STATe? Query state of specified limit test

Description These commands are used to enable or disable LIMIT 1, LIMIT 2, LIMIT 3, and LIMIT 5 to LIMIT 12 tests. Any limit test not enabled is simply not performed.

When a limit test is enabled, the Digital I/O port comes under control of limit tests. That is, the result of the testing process updates the output pattern on the I/O port.

FAIL?

:CALCulate2:LIMit[1]:FAIL?

Read LIMIT 1 test result

:CALCulate2:LIMitx:FAIL?

Read LIMIT x test result (x = 2, 3, 5-12)

Description These commands are used to read the results of LIMIT 1, LIMIT 2, LIMIT 3, and LIMIT 5 to LIMIT 12 tests:

0 = Limit test passed

1 = Limit test failed

The response message (0 or 1) only tells you if a limit test has passed or failed. For Limit 2, Limit 3, and Limit 5-12, it does not tell you which limit (upper or lower) has failed. To determine which limit has failed, you will have to read the Measurement Event Register. (See “[STATus subsystem](#),” [page 18-101](#).)

Reading the results of a limit test does not clear the fail indication of the test. A failure can be cleared by using a :CLEar command.

Composite testing

PASS:SOURce2 <NRf> | <NDN>

:CALCulate2:CLIMits:PASS:SOURce2 <NRf> | <NDN>

Specify composite pass pattern

NOTE The above command to set the composite pass pattern for the Model 2401 is invalid and will cause an undefined header error.

Parameters	<NRf> =	0 to 7 (3-bit)	Decimal value
		0 to 15 (4-bit)	Decimal value
<NDN> =		0 to #b111 (3-bit)	Binary value
		0 to #b1111 (4-bit)	Binary value
		0 to #q7 (3-bit)	Octal value
		0 to #q17 (4-bit)	Octal value
		0 to #h7 (3-bit)	Hexadecimal value
		0 to #hF (4-bit)	Hexadecimal value

Query :SOURce2? Query programmed source value

Description This command is used to define the 3-bit or 4-bit output pattern for the Digital I/O Port when there are no failures. Note that the output value can be specified in binary, octal, decimal, or hexadecimal format. Use the table provided in the “Description” for the :SOURce command to determine the parameter value for the desired decimal digital output pattern.

The SourceMeter can be configured to place the defined pass bit pattern on the digital output immediately when the pass condition occurs, or it can wait until all testing on a device package is completed (operation leaves trigger layer). See “[Composite testing](#),” [page 18-39](#) and “[BCONtrol <name>](#),” [page 18-41](#), for details.

For the sorting mode, this command defines the 3-bit or 4-bit output pass pattern for the Limit 1 test (compliance) when Limits 2, 3, 5-12 are disabled.

FAIL:SOURce2 <NRf> | <NDN>

:CALCulate2:CLIMits:FAIL:SOURce2 <NRf> | <NDN> Specify fail pattern

NOTE *The above command to set the composite fail pattern for the Model 2401 is invalid and will cause an undefined header error.*

Parameters	<NRf> =	0 to 7 (3-bit)	Decimal value
		0 to 15 (4-bit)	Decimal value
	<NDN> =	0 to #b111 (3-bit)	Binary value
		0 to #b1111 (4-bit)	Binary value
		0 to #q7 (3-bit)	Octal value
		0 to #q17 (4-bit)	Octal value
		0 to #h7 (3-bit)	Hexadecimal value
		0 to #hF (4-bit)	Hexadecimal value

Query :SOURce2? Query programmed source value

Description For the sorting mode, this command is used to define the 3-bit or 4-bit output pattern for the Digital I/O Port when there are failures. Note that the output value can be specified using binary, octal, decimal, or hexadecimal format. Use the table provided in the “Description” for the :SOURce command to determine the decimal parameter value for the desired digital output pattern.

FAIL:SMLocation <NRf> | NEXT PASS:SMLocation <NRf> | NEXT

:CALCulate2:CLIMits:FAIL:SMLocation <NRf> | NEXT Specify “fail” source memory location
:CALCulate2:CLIMits:PASS:SMLocation <NRf> | NEXT Specify “pass” source memory location

Parameters <NRf> = 1 to 100 Specify memory location point
NEXT Next memory location point in list
(present location + 1)

Query :SMLocation? Query “pass” or “fail” source memory location

Description While using a Source Memory Sweep when performing limit tests, the sweep can branch to a specified memory location point or proceed to the next memory location in the list.

When a memory location is specified with PASS, the sweep will branch to that memory location if the test is successful (PASS condition). If not successful (FAIL condition), the sweep proceeds to the next memory location in the list. With NEXT selected (the default), the sweep proceeds to the next memory location (present location +

1) in the list regardless of the outcome of the test (PASS or FAIL condition).

When a memory location is specified with FAIL, the sweep will branch to that location on a failure. If not (PASS condition), the sweep proceeds to the next memory location in the list. With NEXT selected (the default), the sweep proceeds to the next memory location (present location +1) in the list regardless of the outcome of the test (FAIL or PASS condition). Note that branch on FAIL is available only via remote.

See [Section 10](#), “Source memory sweep,” for more information.

BCONtrol <name>

	:CALCulate2:CLIMits:BCONtrol <name>	Control Digital I/O port pass/fail update
Parameters	<name> = IMMEDIATE END	Update output when first failure occurs Update output after sweep is completed
Query	:BCONtrol?	Query when digital output will update
Description	<p>This command is used to control when the digital output will update to the pass or fail bit pattern. The pass or fail bit pattern tells the handler to stop the testing process and place the DUT in the appropriate bin.</p> <p>With IMMEDIATE selected, the digital output will update immediately to the bit pattern for the first failure in the testing process. If all the tests pass, the output will update to the pass bit pattern.</p> <p>With END selected, the digital output will not update to the pass or fail bit pattern until the SourceMeter completes the sweep or list operation. This allows multiple test cycles to be performed on DUT. With the use of a scanner card, multi-element devices (i.e. resistor network) can be tested. If, for example, you did not use END and the first element in the device package passed, the pass bit pattern will be output. The testing process will stop and the DUT will be binned. As a consequence, the other elements in the device package are not tested.</p>	

MODE <name>

	:CALCulate2:CLIMits:MODE <name>	Control Digital I/O port pass/fail output
Parameters	<name> = GRADing SORTing	Output graded pass/fail pattern Output sorted pass/fail pattern
Query	:MODE?	Query Digital I/O pass/fail mode
Description	<p>This command controls how limit calculations drive the Digital I/O lines. In GRADing mode, a reading passes if it is within all of the hi/low limit tolerances enabled, assuming that it has passed the LIMIT 4 contact check (contact check option only) and LIMIT 1 compliance tests first. The Digital I/O lines will be driven with the first pattern of</p>	

the first contact check (optional), compliance, hi, or low failure. Otherwise, the CALC2:CLIM:PASS:SOUR2 pattern will be output.

In SORTing mode, a reading will fail if it fails the contact check test, the compliance test, or is not within any of the Digital I/O Bands. If the tests pass and only LIMIT 1 or 4 is enabled,

CALC2:CLIM:PASS:SOUR2 pattern will be output. Otherwise, the first limit test band that passes will output its LOW:SOUR2 pattern (UPP:SOUR2 patterns will be ignored). If LIMIT1 or LIMIT 4 fails, their SOUR2 patterns will be output. If no LIMIT2, 3, 5-12 limit passes, the CALC2:CLIM:FAIL:SOUR2 pattern will be output.

Clear test results

[:IMMEDIATE]

:CALCulate2:CLIMits:CLEar[:IMMEDIATE] Clears test results and resets Digital I/O Port

Description This command clears the test results (pass or fail) of the limit tests and resets the output lines of the Digital I/O port back to the :SOURce2:TTL settings. (See “SOURce2,” page 18-98, subsystem.)

AUTO

:CALCulate2:CLIMits:CLEar:AUTO Control auto-clear for test results

Parameters	 =	1 or ON	Enable auto-clear
		0 or OFF	Disable auto-clear

Query :AUTO? Query state of auto-clear

Description With auto-clear enabled, test results will clear and the output lines of the Digital I/O port will reset when the :INITiate command is sent to start a new test sequence.

When disabled, you must use :IMMEDIATE to perform the clear actions.

CALCulate3

Provides statistical data on buffer readings

Select statistic

FORMat <name>

:CALCulate3:FORMat <name>

Specify CALC3 format

Parameters	<name> =	MEAN	Mean value of readings in buffer
		SDEVIation	Standard deviation of readings in buffer
		MAXimum	Largest reading in buffer
		MINimum	Lowest reading in buffer
		PKPK	MAXimum - MINimum

Query :FORMat? Query programmed math format

Description This command is used to select the desired statistic on readings stored in the buffer. See [Section 9, "Data Store,"](#) for details on these statistics.

Readings stored in the buffer can be "raw" measured readings, the results of the CALC1 calculation, or CALC2 readings. The :TRACe:FEED command in the :TRACe Subsystem is used to select the type of readings to store.

Acquire statistic

:DATA?

:CALCulate3:DATA?

Read CALC3 result

Description This query command is used to perform the selected statistic operation and read the result(s). The result(s) is always returned in ASCII format.

If the buffer is configured to store raw measured readings (:TRACe:FEED SENSE1) and multiple functions were measured, the selected statistic operation will be performed on all the measured readings. For example, if voltage and current measurements were stored in the buffer, then the selected statistic operation will be performed on both readings. Statistics for multiple measurement functions are returned in the following order:

voltage statistic, current statistic, resistance statistic.

Statistic operations are not performed on TIME and STATus data elements that are stored in the buffer.

If the buffer is configured to store the result of CALC1 or CALC2 (:TRACe:FEED CALC1 or CALC2), only one result will be returned by this query command.

Notes:

1. If there is no data in the buffer, error -230, "Data corrupt or stale," will be generated.
2. If there are a lot of readings stored in the buffer, some statistic operations may take too long and cause a bus time-out error. To avoid this, send the :CALA3:DATA? command and then wait for the MAV (message available) bit in the Status Byte Register to set before addressing the SourceMeter to talk. (See [Section 15](#), "Status Structure.")
3. See [Appendix C](#), "Data Flow," for a detailed explanation on how data flows through the various operation blocks of the SourceMeter. It clarifies the types of readings that are acquired by the various commands to read data.

DISPlay subsystem

The display subsystem controls the display of the SourceMeter and is summarized in [Table 18-2](#).

Control display

DIGits <n>

:DISPlay:DIGits <n>

Set display resolution

Parameters	<n> =	4	3.5 digit resolution
		5	4.5 digit resolution
		6	5.5 digit resolution
		7	6.5 digit resolution
		DEFault	5.5 digit resolution
		MINimum	3.5 digit resolution
		MAXimum	6.5 digit resolution

Query	:DIGits?	Query display resolution
	:DIGits? DEFault	Query *RST default resolution
	:DIGits? MINimum	Query lowest allowable display resolution
	:DIGits? MAXimum	Query largest allowable display resolution

Description This command is used to set the display resolution. Note that you can instead use rational numbers. For example, to select 4.5 digit resolution, you can send a parameter value of 4.5 (instead of 5). The SourceMeter rounds the rational number to an integer.

**ENABle **

:DISPlay:ENABle

Control display circuitry

Parameters =
0 or OFF
1 or ONDisable display circuitry
Enable display circuitry**Query**

:ENABle?

Query state of display

Description

This command is used to enable and disable the front panel display circuitry. When disabled, the instrument operates at a higher speed. While disabled, the display is frozen with the following message:

```
FRONT PANEL DISABLED
Press LOCAL to resume.
```

As reported by the message, all front panel controls (except LOCAL and OUTPUT OFF) are disabled. Normal display operation can be resumed by using the :ENABle command to enable the display or by putting the SourceMeter into local.

ATTRIBUTES?

:DISPlay[:WINDow[1]]:ATTRIBUTES?

Query attributes; top display

:DISPlay:WINDow2:ATTRIBUTES?

Query attributes; bottom display

Description

This query command is used to determine which characters on the display are blinking and which are not. The response message provides that status of each character position for the specified display. The primary display consists of 20 characters and the secondary display consists of 32 characters.

1 = Character is blinking

0 = Character is not blinking

For example, assume the following menu is displayed with the SAVESETUP option blinking:

```
MAIN MENU
SAVESETUP COMMUNICATION CAL >
```

The response message for :DISP:ATTR? (top display) will result in 20 zeroes as follows: 00000000000000000000

The response message for :DISP:WIND2:ATTR? (bottom display) will display ones at the character positions for SAVESETUP as follows: 11111111100000000000000000000000

CNDisplay

:DISPlay:CNDisplay

Return to source-measure display state

Description

This action command is used to return the instrument to the source-measure display state (source, measure, and compliance readings displayed). For example, if a menu structure is presently being displayed, this command will exit the menu and return to the source-measure display state.

Description These commands enable and disable the text message modes. When enabled, a defined message is displayed. When disabled, the message is removed from the display.

GPIB Operation — A user defined text message remains displayed only as long as the instrument is in remote. Taking the instrument out of remote (by pressing the LOCAL key or sending LOCAL 27) cancels the message and disables the text message mode.

RS-232 Operation — A user defined test message can be cancelled by sending the :SYSTem:LOCal command or pressing the LOCAL key.

FORMat subsystem

The commands for this subsystem are used to select the data format for transferring instrument readings over the bus. These commands are summarized in [Table 18-3](#).

Data format

[[:DATA] <type>[,length]

:FORMat[:DATA] <type>[,<length>]

Select data format

Parameters <type>[,<length>] = ASCII ASCII format
 REAL,32 IEEE754 single precision format
 SREal IEEE754 single precision format

NOTE <length> is not used for the ASCII or SREal parameters. It is optional for the REAL parameter. If you do not use <length> with the REAL parameter, the <length> defaults to 32 (single precision format).

Query [:DATA]? Query data format

Description This command is used to select the data format for transferring readings over the bus. Only the ASCII format is allowed over the RS-232 interface. This command only affects the output of READ?, FETCh?, MEASure?, TRACe:DATA?, CALC1:DATA? and CALC2:DATA? over the GPIB. All other queries are returned in the ASCII format.

NOTE Regardless of which data format for output strings is selected, the SourceMeter will only respond to input commands using the ASCII format.

ASCII format

The ASCII data format is in a direct readable form for the operator. Most BASIC languages easily convert ASCII mantissa and exponent to other formats. However, some speed is compromised to accommodate the conversion. [Figure 18-1](#) shows an example ASCII string that includes all the data elements. (See “[ELEMEnts <item list>](#),” [page 18-49](#).)

Figure 18-1 also shows the byte order of the data string. Data elements not specified by the :ELEMENTs command are simply not included in the string.

Keep in mind that the byte order can only be reversed for the binary format. (See "BORDER <name>," page 18-54, command.)

Figure 18-1
ASCII data format

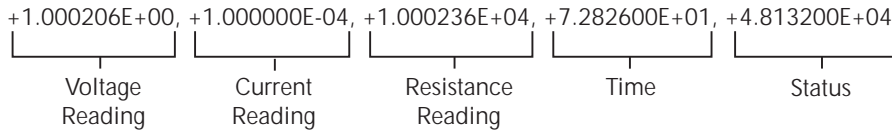

IEEE-754 single precision format

REAL,32, or SREal will select the binary IEEE-754 single precision data format. Figure 18-2 shows the normal byte order format for each data element. For example, if three valid elements are specified, the data string for each reading conversion is made up of three 4-byte data blocks. Note that the data string for each reading conversion is preceded by a 2-byte header that is the binary equivalent of an ASCII # sign and 0. Figure 18-2 does not show the byte for the terminator that is attached to the end of each data string.

Figure 18-2
IEEE-754 single precision data format (32 data bits)

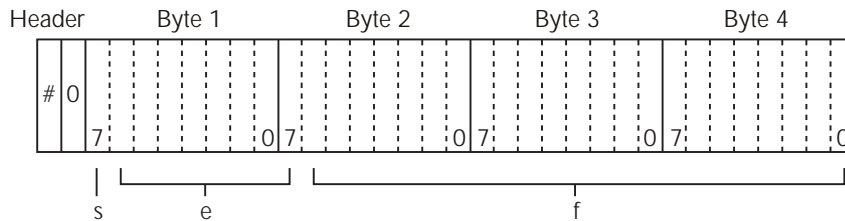

s = sign bit (0 = positive, 1 = negative)
e = exponent bits (8)
f = fraction bits (23)

Normal byte order shown. For swapped byte order, bytes sent in reverse order: Header, Byte 4, Byte 3, Byte 2, Byte 1.

The header and terminator are sent only once for each READ?.

During binary transfers, never un-talk the SourceMeter until after the data is read (input) to the computer. Also, to avoid erratic operation, the readings of the data string (and terminator) should be acquired in

one piece. The header (#0) can be read separately before the rest of the string.

The number of bytes to be transferred can be calculated as follows:

$$\text{Bytes} = 2 + (\text{Rdgs} \times 4) + 1$$

where 2 is the number of bytes for the header (#0).

Rdgs is the product of the number of selected data elements, arm count, and trigger count.

4 is the number of bytes for each reading.

1 is the byte for the terminator.

For example, assume the SourceMeter is configured to perform 10 source-measure operations and send the 10 current measurements to the computer using the binary format.

$$\begin{aligned} \text{Bytes} &= 2 + (10 \times 4) + 1 \\ &= 43 \end{aligned}$$

Data elements

ELEMents <item list>

:FORMat:ELEMents [SENSe[1]] <item list> Specify data elements for data string

Parameters <item list> = VOLTageIncludes voltage reading
 CURRentIncludes current reading
 RESistance Includes resistance reading
 TIMEIncludes timestamp
 STATusIncludes status information

NOTE Each item in the list must be separated by a comma (i.e., :ELEMents, VOLTage, CURRent, RESistance).

Query :ELEMents? Query elements in data string
 This command is used to specify the elements to be included in the data string in response to the following queries:

```
:FETCh?
:READ?
:MEASure?
:TRACe:DATA?
```

You can specify from one to all five elements. Each element in the list must be separated by a comma (.). These elements (shown in [Figure 18-1](#)) are explained as follows:

NOTE An overflow reading reads as +9.9E37.

VOLTage — This element provides the voltage measurement or the programmed voltage source reading. If sourcing voltage and measuring voltage, this element will provide the voltage measurement (measure reading takes priority over source reading). If voltage is not

sourced or measured, the NAN (not a number) value of +9.91e37 is used.

CURRent — This element provides the current measurement or the programmed current source reading. If sourcing current and measuring current, this element will provide the current measurement (measure reading takes priority over source reading). If current is not sourced or measured, the NAN (not a number) value of +9.91e37 is used.

RESistance — This element provides the resistance measurement. If resistance is not measured, the NAN (not a number) value of +9.91e37 is used.

TIME — A timestamp is available to reference each group of readings to a point in time. The relative timestamp operates as a timer that starts at zero seconds when the instrument is turned on or when the relative timestamp is reset (:SYSTem:TIME:RESet). The timestamp for each reading sent over the bus is referenced, in seconds, to the start time. After 99,999.999 seconds, the timer resets to zero and starts over.

NOTE *Timestamp values are approximate. See [Section 9](#) for details.*

Timestamp is also available for buffer readings. Timestamp can be referenced to the first reading stored in the buffer (absolute format) which is timestamped at 0 seconds, or can provide the time between each reading (delta format). The :TRACe:TSTamp:FORMat command is used to select the absolute or delta format.

STATus — A status word is available to provide status information concerning SourceMeter operation. The 24-bit status word is sent in a decimal form and has to be converted by the user to the binary equivalent to determine the state of each bit in the word. For example, if the status value is 65, the binary equivalent is 0000000000001000001. Bits 0 and 6 are set.

The significance of each status bit is explained as follows:

- Bit 0 (OFLO) — Set to 1 if measurement was made while in over-range.
- Bit 1 (Filter) — Set to 1 if measurement was made with the filter enabled.
- Bit 2 (Front/Rear) — Set to 1 if FRONT terminals are selected.
- Bit 3 (Compliance) — Set to 1 if in real compliance.
- Bit 4 (OVP) — Set to 1 if the over voltage protection limit was reached.
- Bit 5 (Math) — Set to 1 if math expression (calc1) is enabled.
- Bit 6 (Null) — Set to 1 if Null is enabled.
- Bit 7 (Limits) — Set to 1 if a limit test (calc2) is enabled.
- Bits 8 and 9 (Limit Results) — Provides limit test results (see grading and sorting modes below).
- Bit 10 (Auto-ohms) — Set to 1 if auto-ohms enabled.
- Bit 11 (V-Meas) — Set to 1 if V-Measure is enabled.
- Bit 12 (I-Meas) — Set to 1 if I-Measure is enabled.
- Bit 13 (Ω -Meas) — Set to 1 if Ω -Measure is enabled.
- Bit 14 (V-Sour) — Set to 1 if V-Source used.
- Bit 15 (I-Sour) — Set to 1 if I-Source used.
- Bit 16 (Range Compliance) — Set to 1 if in range compliance.

Bit 17 (Offset Compensation) — Set to 1 if Offset Compensated Ohms is enabled.

Bit 18 — Contact check failure (see [Appendix F](#)).

Bits 19, 20 and 21 (Limit Results) — Provides limit test results (see grading and sorting modes below).

Bit 22 (Remote Sense) — Set to 1 if 4-wire remote sense selected.

Bit 23 (Pulse Mode) — Set to 1 if in the Pulse Mode.

Description

Bits 8, 9, and 19-21 flag pass/fail conditions for the various limits tests. The bit values for the grading and sorting modes are covered below. See :CALC2:CLIM:MODE and associated commands in “[Calculate subsystems](#),” page 18-26.

Sorting mode status bit values:

Result ¹	Bit #:	21	20	19	9	8	Meas. Event Status ²
Limit 1 and 4 pass and 2, 3, and 5-12 disabled		0	0	0	0	0	Bit 5 (LP)
Limit test 1 fail		0	0	0	0	1	Bit 0 (L1)
Limit test 2 pass		0	0	0	1	0	Bit 5 (LP)
Limit test 3 pass		0	0	0	1	1	Bit 4 (HL3)
Limit test 4 fail		0	0	1	0	1	Bit 10 (CC)
Limit test 5 pass		0	0	1	0	0	Bit 5 (LP)
Limit test 6 pass		0	0	1	1	0	Bit 5 (LP)
Limit test 7 pass		0	0	1	1	1	Bit 5 (LP)
Limit test 8 pass		0	1	0	0	0	Bit 5 (LP)
Limit test 9 pass		0	1	0	0	0	Bit 5 (LP)
Limit test 10 pass		0	1	0	1	0	Bit 5 (LP)
Limit test 11 pass		0	1	0	1	1	Bit 5 (LP)
Limit test 12 pass		0	1	1	0	0	Bit 5 (LP)
Limit 1 and 4 pass and 2, 3, and 5-12 fail		1	1	1	1	1	-

1. Limit 4 test available only with contact check option ([Appendix F](#)).

2. See [Section 15](#), “[Measurement Event Register](#)” and [Figure 15-6](#) for details.

Grading mode status bit values:

Result ¹	Bit #:	21	20	19	9	8	Meas. Event Status ²
All limits pass		0	0	0	0	0	Bit 5 (LP)
Limit test 1 fail		0	0	0	0	1	Bit 0 (L1)
Hi Limit test 2 fail		1	0	0	1	0	Bit 2 (HL2)
Lo Limit test 2 fail		0	0	0	1	0	Bit 1 (LL2)
Hi Limit test 3 fail		1	0	0	1	1	Bit 4 (HL3)
Lo Limit test 3 fail		0	0	0	1	1	Bit 3 (LL3)
Limit test 4 fail		0	0	1	0	1	Bit 10 (CC)
Hi Limit test 5 fail		1	0	1	0	0	-
Lo Limit test 5 fail		0	0	1	0	0	-
Hi Limit test 6 fail		1	0	1	1	0	-
Lo Limit test 6 fail		0	0	1	1	0	-
Hi Limit test 7 fail		1	0	1	1	1	-
Lo Limit test 7 fail		0	0	1	1	1	-
Hi Limit test 8 fail		1	1	0	0	0	-
Lo Limit test 8 fail		0	1	0	0	0	-
Hi Limit test 9 fail		1	1	0	0	1	-
Lo Limit test 9 fail		0	1	0	0	1	-
Hi Limit test 10 fail		1	1	0	1	0	-
Lo Limit test 10 fail		0	1	0	1	0	-
Hi Limit test 11 fail		1	1	0	1	1	-
Lo Limit test 11 fail		0	1	0	1	1	-
Hi Limit test 12 fail		1	1	1	0	0	-
Lo Limit test 12 fail		0	1	1	0	0	-

1. Limit 4 test available only with contact check option ([Appendix F](#)).
2. See [Section 15](#), "Measurement Event Register" and [Figure 15-6](#) for details.

Example reading string

The example ASCII reading string shown in [Figure 18-1](#) shows a measurement of a 10kΩ resistor, with the SourceMeter configured to Source I Measure V. The voltage reading is the voltage measurement (1.000236V), the current reading is the current source value (100Ω, and the operation was performed 72.826 seconds after the SourceMeter was turned on (or after timestamp was reset). The status reading of 48,132 indicates that bits 2, 10, 11, 12, 13, and 15 of the status word are set.

SOURce2 <name>

	:FORMat:SOURce2 <name>	Set SOUR2 and TTL response formats
Parameters	<name> =	
	ASCIi	ASCII format
	HEXadecimal	Hexadecimal format
	OCTal	Octal format
	BINary	Binary format
Query	:SOURce2?	Query response format
Description	This command controls the response format for all CALC2:XXXX:SOUR2 and SOUR2:TTL queries in a manner similar to formats set by the FORM:SREG command. See “Calculate sub-systems,” page 18-26 , and “SOURce subsystem,” page 18-71 , for details.	

CALC data elements**CALCulate <item list>**

	:FORMat:ELEMents:CALCulate <item list>	Set CALC data elements
Parameters	<item list> =	
	CALC	Include CALC1 or CALC2 data
	TIME	Include timestamp
	STATus	Include status information

NOTE Each item in the list must be separated by a comma (for example, :CALCulate CALC,TIME,STAT).

Query	:CALCulate?	Query CALC data element list
Description	This command allows you to retrieve timestamp and status information with the CALC1:DATA? And CALC2:DATA? queries. It also allows you to retrieve timestamp and status information when TRACe:FEED is set to CALC1 or CALC2. See “Calculate sub-systems,” page 18-26 , for a complete description of CALC1 and CALC2. See “Data elements,” page 18-49 , for a description of TIME and STATus information.	

Output enable line

STATe

:OUTPut[1]:IENABle[:STATe] Control output enable

Parameters = 0 or OFF Disable output enable
1 or ON Enable output enable

Query :STATe? Query state of output enable line

Description This command is used to enable or disable the output enable. When enabled, the source cannot be turned on unless the output enable line (pin 8 of the rear panel OUTPUT ENBLE connector) is pulled to a logic low state. When the output enable line goes to a logic high state, the source turns off. See [Section 13](#), “[Digital I/O port](#)” and “[Output enable line](#),” for details about using output enable with a test fixture.

When disabled, the logic level on the outlook enable line has no effect on the output state of the source.

TRIPped?

:OUTPut[1]:ENABle:TRIPped?

Description This query command is used to determine output enable has been tripped. The tripped condition (“1”) means that the source can be turned on (output enable line at logic low level).

A “0” will be returned if the source cannot be turned on (output enable line at logic high level).

Output-off states

SMODe

:OUTPut[1]:SMODe <name> Select output-off mode

Parameters <name> = HIMPedance Disconnect Input/Output
NORMal Normal output-off state
ZERO Zero output-off state
GUARd Guard output-off state

Query :SMODe? Query output off mode

Description This command is used to select the output-off state of the SourceMeter. With HIMPedance selected, the output relay opens when the source is turned off. This disconnects external circuitry from the SourceMeter Input/Output.

NOTE To prevent excessive wear on the output relay, do not use the HIMPedance mode for tests that turn the output on and off frequently.

With NORMal selected, the V-Source is selected and set to 0V when the output is turned off. Compliance is set to 0.5% full scale of the present current range.

In the ZERO output-off state when the V-Source OUTPUT is turned off, the V-Source is set to 0V and current compliance is not changed. When the I-Source OUTPUT is turned off, the V-Source mode is selected and set to 0V. Current compliance is set to the programmed Source I value or to 0.5% full scale of the present current range, whichever is greater.

The ZERO output-off state is typically used with the V-Source and Output Auto-On (see the :SOURce1:CLEar:AUTO command) to generate voltage waveforms that alternate between 0V and the programmed output-on voltage.

With GUARd selected, the I-Source is selected and set to 0A. Voltage compliance is set to 0.5% full scale of the present voltage range. This output-off state should be used when performing 6-wire guarded ohms measurements or for any other load that uses an active source.

NOTE For more information on output-off states, see [Section 13](#), “Output-off states.” For the Model 2430 Pulse Mode, the output-off state is always NORMal.

ROUTE subsystem

The ROUTe subsystem is summarized in [Table 18-5](#).

Select input jacks

TERMinals <name>

:ROUTe:TERMinals <name>

Select front or rear panel in/out jacks

Parameters

<name> = FRONT
REAR

Front panel in/out jacks

Rear panel in/out jacks

Query

:TERMinals?

Query state of front/rear switch setting

Description

This command is used to select which set of input/output terminals to enable (front panel or rear panel).

SENSe1 subsystem

The Sense1 subsystem is used to configure and control the measurement functions of the SourceMeter. Many of the commands are global, where a single command affects all functions. Some commands are unique to a specific function. For example, you can program a unique range setting for each basic function (amps, volts, and ohms).

A function does not have to be selected before you can program its various configurations. Whenever a programmed function is selected, it assumes the programmed states.

The commands for this subsystem are summarized in [Table 18-6](#).

Select measurement functions

CONCurent

	<code>[:SENSe[1]]:FUNCtion:CONCurent </code>	Control concurrent measurements
Parameters	<code> =</code> 0 or OFF 1 or ON	Disable concurrent measurements Enable concurrent measurements
Query	<code>:CONCurent?</code>	Query state of concurrent measurements
Description	<p>This command is used to enable or disable the ability of the instrument to measure more than one function simultaneously. When enabled, the instrument will measure the functions that are selected. (See “[:ON] <function list>,” page 18-59, “OFF <function list>,” page 18-59, and “ALL,” page 18-60.)</p> <p>When disabled, only one measurement function can be enabled. When making the transition from :CONCurent ON to :CONCurent OFF, the voltage (VOLT:DC) measurement function will be selected. All other measurement functions will be disabled. Use the :FUNCTION[:ON] command to select one of the other measurement functions.</p>	

NOTE For the Model 2430 Pulse Mode, concurrent measurements are always disabled. Sending this command results in error +831.

NOTE The function selected with the SENSE:FUNC command will not be displayed on the front panel if concurrent measurements are enabled.

ALL

<code>[:SENSe[1]]:FUNCTION[:ON]:ALL</code>	Enable all measurement functions
<code>[:SENSe[1]]:FUNCTION:OFF:ALL</code>	Disable all measurement functions

Description This command is used to enable or disable all measurement functions.

When enabled (`:ON:ALL`), amps, volts, and ohms measurements will be performed simultaneously if concurrent measurements are enabled. (See “[CONCurrent](#),” page 18-58.) If concurrent measurements are disabled, only the ohms function will be enabled.

The `:OFF:ALL` command disables all measurements.

NOTE For the Model 2430 Pulse Mode, only one function can be enabled. Sending `:FUNCTION:ALL` results in error +831.

COUNT?

<code>[:SENSe[1]]:FUNCTION[:ON]:COUNT?</code>	Query number of functions enabled
<code>[:SENSe[1]]:FUNCTION:OFF:COUNT?</code>	Query number of functions disabled

Description This query command is used to determine the number of functions that are enabled or disabled.

When `:ON:COUNT?` is sent, the response message will indicate the number of functions that are enabled.

When `:OFF:COUNT?` is sent, the response message will indicate the number of functions that are disabled.

STATe? <name>

<code>[:SENSe[1]]:FUNCTION:STATe <name></code>	Query state of specified function
--	-----------------------------------

Parameters	<code><name> = "CURRENT[:DC]"</code>	Amps measurement function
	<code>"VOLTage[:DC]"</code>	Volts measurement function
	<code>"RESistance"</code>	Ohms measurement function

NOTE The function name must be enclosed in double or single quotes (i.e., `:func:stat? "volt"`).

Description This command is used to query the state of the specified measurement function. A returned response message of “0” indicates that the specified function is disabled, while a “1” indicates that the function is enabled.

RESistance:MODE <name>

[:SENSe[1]]:RESistance:MODE <name>

Select ohms measurement mode

Parameters	<name> =	MANual	Manual ohms mode
		AUTO	Auto ohms mode

Query	:MODE?	Query ohms mode
--------------	--------	-----------------

Description This command is used to select the ohms measurement mode. With MANual ohms selected, the user must configure the source and measure aspects of the operation. When the ohms function is selected, the ohms reading is simply the result of the V/I calculation. Range changes cannot be made in manual ohms.

With AUTO ohms selected, the SourceMeter will be configured to Source I Measure V when the ohms function is selected. The current source value and voltage measurement range used depends on the ohms measurement range that is selected.

See [Section 4, "Ohms Measurements,"](#) for details on manual and auto ohms.

**RESistance:OCOMpensated **

[:SENSe[1]]:RESistance:OCOMpensated

Control offset-compensated ohms

Parameters	 =	1 or ON	Enable offset compensation
		0 or OFF	Disable offset compensation

Query	:OCOMpensated?	Query state of offset compensation
--------------	----------------	------------------------------------

Description This command is used to enable or disable offset-compensated ohms. When using the auto ohms measurement mode, the current source level is automatically set. When using the manual ohms measurement mode, you must set the source (V or I) output level.

See [Section 4, "Offset-compensated ohms,"](#) for details on making offset-compensated ohms measurements.

NOTE *Offset-compensated ohms will disable when the :MEASure? command (for the resistance function) or the :CONFigure:RESistance command is sent.*

NOTE *For the Model 2430 Pulse Mode, offset-compensated ohms cannot be enabled using this command. Sending this command results in error +831.*

Select measurement range

Notes:

1. You cannot select a current measurement range if sourcing current. Conversely, you cannot select a voltage measurement range if sourcing voltage. Also, autorange cannot be enabled for those source-measure configurations. The programmed source range determines measurement range.
2. You cannot select an ohms measurement range if in manual ohms (you must be in auto ohms).
3. The highest current measurement range that can be selected is limited by the current compliance range. For example, if current compliance is set for 50mA (100mA range), then the highest available current measurement range is 100mA. Similarly, the highest voltage measurement range is limited by the voltage compliance range.
4. Measurement range limitations:
 - 2400** — With the 200V source range selected, the highest current measurement range is 100mA. With the 1A source range selected, the highest voltage measurement range is 20V.
 - 2400-LV and 2401** — With the 20V source range selected, the highest current measurement range is 1A. With the 1A source range selected, the highest voltage measurement range is 20V.
 - 2410** — With the 1kV source range selected, the highest current measurement range is 20mA. With the 1A or 100mA source range selected, the highest voltage measurement range is 20V.
 - 2420** — With the 60V source range selected, the highest current measurement range is 1A. With the 1A source range selected, the highest voltage measurement range is 60V. With the 3A source range selected, the highest voltage measurement range is 20V.
 - 2425 and 2430 DC Mode** — With the 100V source range selected, the highest current measurement range is 1A. With the 1A source range selected, the highest voltage measurement range is 100V. With the 3A source range selected, the highest voltage measurement range is 20V.
 - 2430 Pulse Mode** — With the 100V source range selected, the highest current measurement range is 10A. With the 10A source range selected, the highest voltage measurement range is 100V. Auto range cannot be used in the Pulse Mode.
 - 2440** — With the 40V source range selected, the highest current measurement range is 1A. With the 1A source range selected, the highest voltage measurement range is 42V. With the 5A source range selected, the highest voltage measurement range is 10.5V.
5. The highest measurement range for the Models 2400-LV and 2401 is 20V. Selecting a higher range over the bus will generate error -222 (Parameter data out of range). The SourceMeter will go to the 20V range.

[:UPPer] <n>

[:SENSe[1]]:CURRent[:DC]:RANGe[:UPPer] <n>|UP|DOWN Select range for amps

[:SENSe[1]]:VOLTage[:DC]:RANGe[:UPPer] <n>|UP|DOWN Select range for volts

[:SENSe[1]]:RESistance:RANGe[:UPPer] <n>|UP|DOWN Select range for ohms

Parameters 2400

<n> =

-1.05 to 1.05	Expected reading in amps
-210 to 210	Expected reading in volts
0 to 2.1e8	Expected reading in ohms
DEFault	1.05e-4 (amps), 21 (volts), 2.1e5 (ohms)
MINimum	-1.05 (amps), -210 (volts), 0 (ohms)
MAXimum	1.05 (amps), 210 (volts), 2.1e8 (ohms)
UP	Select next higher measure range
DOWN	Select next lower measure range

2400-LV and 2401

<n> =

-1.05 to 1.05	Expected reading in amps
-21 to 21	Expected reading in volts
0 to 2.1e8	Expected reading in ohms
DEFault	1.05e-4 (amps), 21 (volts), 2.1e5 (ohms)
MINimum	-1.05 (amps), -21 (volts), 0 (ohms)
MAXimum	1.05 (amps), 21 (volts), 2.1e8 (ohms)
UP	Select next higher measure range
DOWN	Select next lower measure range

2410

<n> =

-1.05 to 1.05	Expected reading in amps
-1100 to 1100	Expected reading in volts
0 to 2.1e8	Expected reading in ohms
DEFault	1.05e-4 (amps), 21 (volts), 2.1e5 (ohms)
MINimum	-1.05 (amps), -1100 (volts), 0 (ohms)
MAXimum	1.05 (amps), 1100 (volts), 2.1e8 (ohms)
UP	Select next higher measurement range
DOWN	Select next lower measurement range

2420

<n> =

-3.15 to 3.15	Expected reading in amps
-63 to 63	Expected reading in volts
0 to 2.1e7	Expected reading in ohms
DEFault	1.05e-4 (amps), 21 (volts), 2.1e5 (ohms)
MINimum	-3.15 (amps), -63 (volts), 0 (ohms)
MAXimum	3.15 (amps), 63 (volts), 2.1e7 (ohms)
UP	Select next higher measurement range
DOWN	Select next lower measurement range

2425 and 2430 DC Mode

<n> =

-3.15 to 3.15	Expected reading in amps
-105 to 105	Expected reading in volts
0 to 2.1e7	Expected reading in ohms
DEFault	1.05e-4 (amps), 21 (volts), 2.1e5 (ohms)
MINimum	-3.15 (amps), -105 (volts), 0 (ohms)

	MAXimum	3.15 (amps), 105 (volts), 2.1e7 (ohms)
	UP	Select next higher measurement range
	DOWN	Select next lower measurement range
	2430 Pulse Mode	
<n> =	-10.5 to 10.5	Expected reading in amps
	-105 to 105	Expected reading in volts
	0 to 2.1e7	Expected reading in ohms
	DEFault	1.05e-4 (amps), 21 (volts), 2.1e5 (ohms)
	MINimum	-10.5 (amps), -105 (volts), 0 (ohms)
	MAXimum	10.5 (amps), 105 (volts), 2.1e7 (ohms)
	UP	Select next higher measurement range
	DOWN	Select next lower measurement range
	2440	
<n> =	-5.25 to 5.25	Expected reading in amps
	-42 to 42	Expected reading in volts
	0 to 2.1e7	Expected reading in ohms
	DEFault	1.05e-4 (amps), 10.5 (volts), 2.1e4 (ohms)
	MINimum	0 (amps), 0 (volts), 0 (ohms)
	MAXimum	5.25 (amps), 42 (volts), 2.1e7 (ohms)
	UP	Select next higher measurement range
	DOWN	Select next lower measurement range
Query	:RANGe?	Query measurement range
	:RANGe? DEFault	Query *RST default range
	:RANGe? MINimum	Query lowest range (returns 0)
	:RANGe? MAXimum	Query highest range
Description	<p>This command is used to manually select the measurement range for the specified measurement function. The range is selected by specifying the expected reading. The instrument will then go to the most sensitive reading that will accommodate that reading. For example, if you expect a reading of approximately 50mV, then simply let <n> = 0.05 (or 50e-3) in order to select the 200mV range.</p> <p>You can also use the UP and DOWN parameters to select range. Each time UP or DOWN is sent, the next higher or lower measurement range is selected. When on the maximum range, sending UP is a No-Op (no operation). When on the lowest range, sending DOWN is a NO-Op.</p> <p>Measurement ranges can instead be automatically selected by the instrument. (See "AUTO ," page 18-42.)</p>	

ULIMit <n>

	[:SENSe[1]]:CURRent[:DC]:RANGe:AUTO:ULIMit?	Query auto ranging upper limit for amps
	[:SENSe[1]]:VOLTage[:DC]:RANGe:AUTO:ULIMit?	Query auto ranging upper limit for volts
	[:SENSe[1]]:RESistance:RANGe:AUTO:ULIMit <n>	Set auto ranging upper limit for ohms
Parameters	<n> =	-2.1e8 to 2.1e8 Ohms upper limit (2400 and 2410) -2.1e7 to 2.1e7 Ohms upper limit (2420, 2425, 2430, and 2440)
Query	:ULIMit?	Query auto range upper limit
Description	Auto range upper limits are intended primarily for SYST:RCM MULT support. (See "SYSTem subsystem," page 18-103.) For voltage and current, the upper limit is controlled by the compliance range and, therefore, is available only as a query. When autoranging is disabled, you can manually program the unit for any range above the upper limit (ohms only).	

Current range holdoff**HOLDoff ****HOLDoff:DElay <NRf>**

	[:SENSe[1]]:CURRent[:DC]:RANGe:HOLDoff 	Enable/disable current range holdoff
	[:SENSe[1]]:CURRent[:DC]:RANGe:HOLDoff:DElay <NRf>	Set holdoff delay
Parameters	 =	Enable (ON) or disable (OFF)
	<NRf> =	Delay in seconds (0 to 999.9999)
Query	HOLDoff?	Query holdoff state
	DElay?	Query holdoff delay
Description	Current range holdoff adds the ability to speed up low-current measurements when sourcing voltage and measurement current. This feature is only available when doing source memory sweeps. It will momentarily set the measure range to the compliance range to overcome the effects of capacitance by charging any capacitance on the higher compliance range, but return to the lower measure range to obtain a good low current measurement. This avoids being limited by range compliance, which would require either a longer delay time or having to take the current measurement on a higher current range. This feature is available only by remote, but parameters are saved for each source memory location.	

Set compliance parameters

[:LEVel] <n>

[:SENSe[1]]:CURRent[:DC]:PROTection[:LEVel] <n> Set current compliance
 [:SENSe[1]]:VOLTagE[:DC]:PROTection[:LEVel] <n> Set voltage compliance

Parameters	2400	
	<n> =	-1.05 to 1.05 -210 to 210 DEFault MINimum MAXimum
		Current compliance limit Voltage compliance limit 105uA, 21V -1.05A, -210V 1.05A, 210V
	2400-LV and 2401	
	<n> =	-1.05 to 1.05 -21 to 21 DEFault MINimum MAXimum
		Current compliance limit Voltage compliance limit 105uA, 21V -1.05A, -21V 1.05A, 21V
	2410	
	<n> =	-1.05 to 1.05 -1100 to 1100 DEFault MINimum MAXimum
		Current compliance limit Voltage compliance limit 105uA, 21V -1.05A, -1100V 1.05A, 1100V
	2420	
	<n> =	-3.15 to 3.15 -63 to 63 DEFault MINimum MAXimum
		Current compliance limit Voltage compliance limit 105uA, 21V -3.15A, -63V 3.15A, 63V
	2425 and 2430 DC Mode	
	<n> =	-3.15 to 3.15 -105 to 105 DEFault MINimum MAXimum
		Current compliance limit Voltage compliance limit 105uA, 21V -3.15A, -105V 3.15A, 105V
	2430 Pulse Mode	
	<n> =	-10.5 to 10.5 -105 to 105 DEFault MINimum MAXimum
		Current compliance limit Voltage compliance limit 105uA, 21V -10.5A, -105V 10.5A, 105V
	2440	
	<n> =	-5.25 to 5.25 -42 to 42 DEFault MINimum
		Current compliance limit Voltage compliance limit 105uA, 21V -5.25A, -42V

	MAXimum	5.25A, 42V
Query	:LEVel?	Query compliance value
	:LEVel? DEFault	Query *RST default compliance
	:LEVel? MINimum	Query minimum allowable compliance
	:LEVel? MAXimum	Query maximum allowable compliance
Description	<p>This command is used to set compliance limits. A current compliance limit is set for the V-Source, and a voltage compliance limit is set for the I-Source. The SourceMeter cannot source levels that exceed these specified limits.</p> <p>The :SENSe:CURRent:PROTection[:LIMit] command is used to set the current compliance for the V-Source and the :SENSe:VOLTagE:PROTection[:LIMit] command is used to set the voltage compliance for the I-Source.</p>	

NOTE You cannot set compliance less than 0.1% of the present measurement range.

RSYNhronize

	:SENSe[1]:CURRent[:DC]:PROTection:RSYNchronize 	Control current measure and compliance range sync
	:SENSe[1]:VOLTagE[:DC]:PROTection:RSYNchronize 	Control voltage measure and compliance range sync
Parameters	 =	OFF Disable range sync ON Enable range sync

Description Turning this feature on will make the measurement range follow the compliance range setting when autoranging is off. When the compliance value is set, the measurement range will be on the same range as the compliance setting. The two commands above change one setting; changing the state of one will automatically change the other.

TRIPped?

	:SENSe[1]:CURRent[:DC]:PROTection:TRIPped?	Query current compliance state
	:SENSe[1]:VOLTagE[:DC]:PROTection:TRIPped?	Query voltage compliance state
Description	<p>This command is used to determine if the source is in compliance. If a "1" is returned, then the source is in compliance. A "0" indicates that the source is not in compliance.</p> <p>The :CURRent:PROTection:TRIPped? command is used to check the compliance state of the V-Source, and the :VOLTagE:PROTection:TRIPped? command is used to check the compliance state of the I-Source.</p>	

Set measurement speed

NPLCycles <n>

```
[:SENSe[1]]:CURRent[:DC]:NPLCycles <n>      Set speed (PLC)
[:SENSe[1]]:VOLTAge[:DC]:NPLCycles <n>      Set speed (PLC)
[:SENSe[1]]:RESistance:NPLCycles <n>        Set speed (PLC)
```

Parameters	<n> =	0.01 to 10	Power-line cycles per integration
		DEFault	1
		MINimum	0.01
		MAXimum	10
	Model 2430 Pulse Mode:		
	<n> =	0.01 to 0.1	Power-line cycles per integration
		DEFault	0.1
		MINimum	0.01
		MAXimum	0.1

Query	:NPLCycles?	Query programmed PLC value
	:NPLCycles? DEFault	Query *RST default PLC
	:NPLCycles? MINimum	Query minimum PLC
	:NPLCycles? MAXimum	Query maximum PLC

Description This command is used to set the integration period (speed) for measurements. NPLC (Number of Power Line Cycles) expresses the integration period by basing it on the power line frequency. For example, for a PLC of 1, the integration period would be 1/60 (for 60Hz line power) which is 16.67 msec.

Note that this is a global command. Thus, if you set the speed for voltage measurements to 10 PLC, then current and resistance will also set to 10 PLC.

NOTE For the Model 2430 Pulse Mode, speed can be set from 0.004 to 0.100 PLC.

Configure and control filter

NOTE For the Model 2430 Pulse Mode, filtering is not used. Therefore, the following filter commands are not valid for the Model 2430 Pulse Mode.

TCONtrol <name>

	[:SENSe[1]]:AVERAge:TCONtrol <name>	Select filter type
Parameters	<name> = REPeat MOVing	Repeating filter Moving filter
Query	:TCONtrol?	Query filter type
Description	This command is used to select the type of averaging filter (REPeat or MOVing). These filter types are explained in Section 7, "Filters." The number of readings that are averaged by the filter is set with the :AVERAge:COUNt command. The :AVERAge:STATe command is used to enable or disable the filter.	

NOTE For the Model 2430 Pulse Mode, this command is ignored.

COUNt <n>

	[:SENSe[1]]:AVERAge:COUNt <n>	Specify filter count
Parameters	<n> = to 100 DEFault MINimum MAXimum	Specify filter count 10 1 100
Query	:COUNt? :COUNt? DEFault :COUNt? MINimum :COUNt? MAXimum	Query filter count Query the *RST default filter count Query the lowest allowable filter count Query the largest allowable filter count
Description	These commands are used to specify the filter count. In general, the filter count is the number of readings that are acquired and stored in the filter buffer for the averaging calculation. The larger the filter count, the more filtering that is performed.	

NOTE For the Model 2430 Pulse Mode, this command is ignored.

**[[:STATE] **

[:SENSe[1]]:AVERage[:STATE] Enable or disable filter

Parameters	 =	0 or OFF	Disable digital filter
		1 or ON	Enable digital filter

Query	:STATE?	Query state of digital filter
--------------	---------	-------------------------------

Description These commands are used to enable or disable the digital averaging filter. When enabled, voltage, current, and resistance readings are filtered according to how the filter is configured.

NOTE For the Model 2430 Pulse Mode, this command is invalid (error +831).

SOURce subsystem

This subsystem is used to configure and control the I-Source and V-Source, and to set the logic level (high or low) of each digital output line. The commands for this subsystem are summarized in [Table 18-7](#).

SOURce[1]

Use the following commands to configure and control the I-Source and V-Source. At the end of this subsystem are program examples of sweeps and lists.

Control source output-off

[[:IMMediate]

[:SOURce[1]]:CLEar[:IMMediate] Turn source output off

Description This command is used to turn off the source output. The output will turn off after all programmed source-measure operations are completed and the instrument returns to the idle state.

Note that if auto output-off is enabled, the source output will automatically turn off. (See next command.)

AUTO

	:SOURce[1]:CLEar:AUTO 	Control auto out-put off
	:SOURce[1]:CLEar:AUTO:MODE <name>	Select auto mode
Parameters	 = 1 or ON	Enable auto output-off
	= 0 or OFF	Disable auto output-off
	<name> = ALWAYS	On/off with each SDM cycle
	TCOunt	Off after trigger count
Query	:AUTO?	Query state of auto output-off
	:MODE?	Query mode
Description	<p>This command is used to control auto output-off for the source. With auto output-off enabled, an :INITiate (or :READ? or MEASure?) will start source-measure operation. The output will turn on at the beginning of each SDM (source-delay-measure) cycle and turn off after each measurement is completed.</p> <p>With auto output-off disabled, the source output must be on before an :INITiate or :READ? can be used to start source-measure operation. The :MEASure? command will automatically turn on the source output. Once operation is started, the source output will stay on even after the instrument returns to the idle state. Auto output-off disabled is the *RST and :SYSTem:PRESet default.</p> <p>For the :MODE command, the source will turn off after every SDM cycle with the ALWAYS option. With the TCOunt option, the source will turn off when the trigger count has expired.</p>	

WARNING With auto output-off disabled, the source output will remain on after all programmed source-measure operations are completed. Beware of hazardous voltage that may be present on the output terminals.

NOTE For the Model 2430 Pulse Mode, auto output-off is always enabled. This command is ignored.

Select function modes

SHAPE <name> (Model 2430 only)

	:SOURce[1]:FUNCTion:SHAPE <name>	Select output mode
Parameters	<name> = DC	Select DC Mode
	PULSE	Select Pulse Mode
Query	:SHAPE?	Query selected output mode
Description	<p>This command is used to select the output mode for the Model 2430. The DC parameter selects the DC Mode of operation, and PULSE selects the Pulse Mode.</p>	

[[:MODE] <name>

	:SOURce[1]:FUNction[:MODE] <name>	Select source mode
Parameters	<name> = VOLTage CURRent MEMory	Select voltage mode Select current mode Select memory mode
Query	[:MODE]?	Query selected source
Description	<p>This command is used to select the source mode. With VOLTage selected, the V-Source will be used, and with CURRent selected, the I-Source will be used.</p> <p>With MEMory selected, a memory sweep can be performed. Operating setups (up to 100) saved in memory can be sequentially recalled. This allows multiple source/measure functions to be used in a sweep.</p>	

Select sourcing mode**MODE <name>**

	:SOURce[1]:CURRent:MODE <name>	Select DC sourcing mode for I-Source
	:SOURce[1]:VOLTage:MODE <name>	Select DC sourcing mode for V-Source
Parameters	<name> = FIXEd LIST SWEep	Select fixed sourcing mode Select list sourcing mode Select sweep sourcing mode
Query	:MODE?	Query DC sourcing mode
Description	<p>This command is used to select the DC sourcing mode for the specified source. The three modes are explained as follows:</p> <p>FIXEd — In this DC sourcing mode, the specified source will output a fixed level. Use the :RANGe and :AMPLitude commands to specify the fixed source level. (See “Select range,” page 18-74, and “Set amplitude for fixed source,” page 18-77.)</p> <p>LIST — In this mode, the source will output levels that are specified in a list. See “Configure list” for commands to define and control the execution of the list.</p> <p>SWEep — In this mode, the source will perform a voltage, current or memory sweep. See “Configure voltage and current sweeps,” page 18-83, and “Configure memory sweep,” page 18-93, for commands to define the sweep.</p>	

NOTE *The sourcing mode will default to FIXEd whenever the SourceMeter goes to the local state.*

Select range

RANGe <n>

:SOURce[1]:CURRent:RANGe <n>

Select range for I-Source

:SOURce[1]:VOLTage:RANGe <n>

Select range for V-Source

Parameters

2400/2400-LV/2401

<n> = -1.05 to 1.05
-210 to 210

Specify I-Source level (amps)
Specify V-Source level (volts)
(-21 to 21 for 2400-LV and 2401)

DEFault

100µA range (I-Source)
20V range (V-Source)

MINimum

1µA range (I-Source)
200mV range (V-Source)
(20V range, 2400-LV and 2401)

MAXimum

1A range (I-Source)
200V range (V-Source) (20V,
2400-LV and 2401)

UP

Select next higher range

DOWN

Select next lower range

2410

<n> = -1.05 to 1.05
-1100 to 1100
DEFault

Specify I-Source level (amps)
Specify V-Source level (volts)
100µA range (I-Source)
20V range (V-Source)

MINimum

1µA range (I-Source)
200mV range (V-Source)

MAXimum

1A range (I-Source)
1100V range (V-Source)

UP

Select next higher range

DOWN

Select next lower range

2420

<n> = -3.15 to 3.15
-63 to 63
DEFault

Specify I-Source level (amps)
Specify V-Source level (volts)
100µA range (I-Source)
20V range (V-Source)

MINimum

10µA range (I-Source)
200mV range (V-Source)

MAXimum

3A range (I-Source)
63V range (V-Source)

UP

Select next higher range

DOWN

Select next lower range

2425 and 2430 DC Mode

<n> =	-3.15 to 3.15	Specify I-Source level (amps)
	-105 to 105	Specify V-Source level (volts)
	DEFault	100µA range (I-Source)
		20V range (V-Source)
	MINimum	10µA range (I-Source)
		200mV range (V-Source)
	MAXimum	3A range (I-Source)
		100V range (V-Source)
	UP	Select next higher range
	DOWN	Select next lower range

2430 Pulse Mode

<n> =	-10.5 to 10.5	Specify I-Source level (amps)
	-105 to 105	Specify V-Source level (volts)
	DEFault	100µA range (I-Source)
		20V range (V-Source)
	MINimum	10µA range (I-Source)
		200mV range (V-Source)
	MAXimum	10A range (I-Source)
		100V range (V-Source)
	UP	Select next higher range
	DOWN	Select next lower range

2440

<n> =	-5.25 to 5.25	Specify I-Source level (amps)
	-42 to 42	Specify V-Source level (volts)
	DEFault	100µA range (I-Source)
		10V range (V-Source)
	MINimum	10µA range (I-Source)
		200mV range (V-Source)
	MAXimum	5A range (I-Source)
		40V range (V-Source)
	UP	Select next higher range
	DOWN	Select next lower range

Query	:RANGe?	Query range for specified source
	:RANGe? DEFault	Query *RST default source range
	:RANGe? MINimum	Query lowest source range
	:RANGe? MAXimum	Query highest source range

Description This command is used to manually select the range for the specified source. Range is selected by specifying the approximate source magnitude that you will be using. The instrument will then go to the lowest range that can accommodate that level. For example, if you expect to source levels around 3V, send the following command:

```
:SOURce:VOLTage:RANGe 3
```

The above command will select the 20V range for the V-Source.

As listed in the “Parameters,” you can also use the MINimum, MAXimum and DEFault parameters to manually select the source range. The UP parameter selects the next higher source range, while DOWN selects the next lower source range.

Note that source range can be selected automatically by the instrument (see next command).

AUTO

:SOURce[1]:CURRent:RANGe:AUTO

Select auto range for I-Source

:SOURce[1]:VOLTage:RANGe:AUTO

Select auto range for V-Source

Parameters	 =	0 or OFF	Disable auto range
		1 or ON	Enable auto range

Query	AUTO?	Query state of auto range
--------------	-------	---------------------------

Description This command is used to enable or disable auto range for the specified source. When enabled, the instrument will automatically select the most sensitive range for the specified source level. When disabled, the instrument will use the range that the instrument is currently on.

Auto range will be disabled if a fixed range is selected (see previous command).

Both *RST and :SYSTem:PREset enables source auto range. When the SourceMeter goes into the local state, source auto range disables.

Set amplitude for fixed source

[:IMMEDIATE][:AMPLITUDE] <n>

:SOURCE[1]:CURRENT[:LEVEL][:IMMEDIATE][:AMPLITUDE] <n> Set fixed I-Source amplitude immediately

:SOURCE[1]:VOLTAGE[:LEVEL][:IMMEDIATE][:AMPLITUDE] <n> Set fixed V-Source amplitude immediately

Parameters	2400/2400-LV/2401	
<n> =	-1.05 to 1.05	Set I-Source amplitude (amps)
	-210 to 210	Set V-Source amplitude (volts)
	DEFAULT	0A or 0V
	MINIMUM	-1.05A or -210V
	MAXIMUM	+1.05A or +210V (+21V, 2400-LV and 2401)
2410		
<n> =	-1.05 to 1.05	Set I-Source amplitude (amps)
	-1100 to 1100	Set V-Source amplitude (volts)
	DEFAULT	0A or 0V
	MINIMUM	-1.05A or -1100V
	MAXIMUM	+1.05A or +1100V
2420		
<n> =	-3.15 to 3.15	Set I-Source amplitude (amps)
	-63 to 63	Set V-Source amplitude (volts)
	DEFAULT	0A or 0V
	MINIMUM	-3.15A or -63V
	MAXIMUM	+3.15A or +63V
2425 and 2430 DC Mode		
<n> =	-3.15 to 3.15	Set I-Source amplitude (amps)
	-105 to 105	Set V-Source amplitude (volts)
	DEFAULT	0A or 0V
	MINIMUM	-3.15A or -105V
	MAXIMUM	+3.15A or +105V
2430 Pulse Mode		
<n> =	-10.5 to 10.5	Set I-Source amplitude (amps)
	-105 to 105	Set V-Source amplitude (volts)
	DEFAULT	0A or 0V
	MINIMUM	-10.5A or -105V
	MAXIMUM	+10.5A or +105V
2440		
<n> =	-5.25 to 5.25	Set I-Source amplitude (amps)
	-42 to 42	Set V-Source amplitude (volts)
	DEFAULT	0A or 0V
	MINIMUM	-5.25A or -42V
	MAXIMUM	+5.25A or +42V

Query	:CURRent?	Query programmed amplitude of I-Source
	:CURRent? DEFault	Query *RST default amplitude
	:CURRent? MINimum	Query lowest allowable amplitude
	:CURRent? MAXimum	Query highest allowable amplitude
	:VOLTage?	Query programmed amplitude of V-Source
	:VOLTage? DEFault	Query *RST default amplitude
	:VOLTage? MINimum	Query lowest allowable amplitude
	:VOLTage? MAXimum	Query highest allowable amplitude

Description This command is used to immediately update the amplitude of a fixed source. This command is not valid for the list or sweep mode.

NOTE *The sourcing :MODE command is used to select a fixed source. (See “Select sourcing mode,” page 18-73.)*

If a manual source range is presently selected, then the specified amplitude cannot exceed that range. For example, if the V-Source is on the 2V range (auto range disabled), you will not be able to set the V-Source amplitude to 3V. In auto range, the amplitude can be set to any level that is within the capabilities of the source.

The MINimum and MAXimum parameters are only valid if the highest source range is presently selected. Sending the MINimum or MAXimum parameters on a lower source range will generate error -221 (Setting Conflict).

TRIGgered[:AMPLitude] <n>

:SOURce[1]:CURRent[:LEVel]:TRIGgered[:AMPLitude] <n> Set fixed I-Source amplitude when triggered

:SOURce[1]:VOLTage[:LEVel]:TRIGgered[:AMPLitude] <n> Set fixed V-Source amplitude when triggered

Parameters

2400/2400-LV/2401

<n> =	-1.05 to 1.05	Set I-Source amplitude (amps)
	-210 to 210	Set V-Source amplitude (volts)
		(-21 to 21, 2400-LV and 2401)
	DEFault	0A or 0V
	MINimum	-1.05A or -210V
	MAXimum	+1.05A or +210V

2410

<n> =	-1.05 to 1.05	Set I-Source amplitude (amps)
	-1100 to 1100	Set V-Source amplitude (volts)
	DEFault	0A or 0V
	MINimum	-1.05A or -1100V
	MAXimum	+1.05A or +1100V

2420

<n> =	-3.15 to 3.15	Set I-Source amplitude (amps)
	-63 to 63	Set V-Source amplitude (volts)
	DEFault	0A or 0V
	MINimum	-3.15A or -63V
	MAXimum	+3.15A or +63V

2425 and 2430 DC Mode

<n> =	-3.15 to 3.15	Set I-Source amplitude (amps)
	-105 to 105	Set V-Source amplitude (volts)
	DEFault	0A or 0V
	MINimum	-3.15A or -105V
	MAXimum	+3.15A or +105V

2430 Pulse Mode

<n> =	-10.5 to 10.5	Set I-Source amplitude (amps)
	-105 to 105	Set V-Source amplitude (volts)
	DEFault	0A or 0V
	MINimum	-10.5A or -105V
	MAXimum	+10.5A or +105V

2440

<n> =	-5.25 to 5.25	Set I-Source amplitude (amps)
	-42 to 42	Set V-Source amplitude (volts)
	DEFault	0A or 0V
	MINimum	-5.25A or -42V
	MAXimum	+5.25A or +42V

Query	:TRIGgered?	Query triggered amplitude for fixed source
	:TRIGgered? DEFault	Query *RST default amplitude
	:TRIGgered? MINimum	Query lowest allowable amplitude
	:TRIGgered? MAXimum	Query highest allowable amplitude

Description This command performs the same as the [:IMMediate][:AMPLitude] command except that the amplitude is not updated immediately. With this command, the amplitude is updated when the SourceMeter is triggered to perform a source-measure operation. For example, if the instrument is waiting in the trigger layer for an external trigger, the amplitude of the source will not update until that external trigger is received by the SourceMeter. See [Section 11](#), “Trigger models,” for details on trigger model operation.

The MINimum and MAXimum parameters are only valid if the highest source range is presently selected. Sending the MINimum or MAXimum parameters on a lower source range will generate error -221 (Setting Conflict).

Set voltage limit

[:LEVel] <n>

:SOURce[1]:VOLTage:PROTection[:LEVel] <n> Set voltage limit for V-Source

Parameters 2400

<n> =	-210 to 210	Specify V-Source limit
	20	Set limit to 20V
	40	Set limit to 40V
	60	Set limit to 60V

	80	Set limit to 80V
	100	Set limit to 100V
	120	Set limit to 120V
	160	Set limit to 160V
	161 to 210	Set limit to 210V (NONE)
	DEFault	Set limit to 210V (NONE)
	MINimum	Set limit to 20V
	MAXimum	Set limit to 210V (NONE)
2401		
<n> =	-40 to 40	Specify V-Source limit
	20	Set limit to 20V
	DEFault	Set limit to 40V (NONE)
	MINimum	Set limit to 20V
	MAXimum	Set limit to 40V (NONE)
2410		
<n> =	-1100 to 1100	Specify V-Source limit
	20	Set limit to 20V
	40	Set limit to 40V
	100	Set limit to 100V
	200	Set limit to 200V
	300	Set limit to 300V
	400	Set limit to 400V
	500	Set limit to 500V
	501 to 1100	Set limit to NONE
	DEFault	Set limit to 1100V (NONE)
	MINimum	Set limit to 20V
	MAXimum	Set limit to 1100V (NONE)
2420		
<n> =	-63 to 63	Specify V-Source limit
	6	Set limit to 6V
	12	Set limit to 12V
	18	Set limit to 18V
	24	Set limit to 24V
	30	Set limit to 30V
	36	Set limit to 36V
	48	Set limit to 48V
	49 to 63	Set limit to NONE
	DEFault	Set limit to 63V (NONE)
	MINimum	Set limit to 6V
	MAXimum	Set limit to 63V (NONE)
2425 and 2430		
<n> =	-105 to 105	Specify V-Source limit
	10	Set limit to 10V
	20	Set limit to 20V
	30	Set limit to 30V
	40	Set limit to 40V

	50	Set limit to 50V
	60	Set limit to 60V
	80	Set limit to 80V
	81 to 105	Set limit to NONE
	DEFault	Set limit to 105V (NONE)
	MINimum	Set limit to 10V
	MAXimum	Set limit to 105V (NONE)
2440		
	<n> = -42 to 42	Specify V-Source limit
	4	Set limit to 4V
	8	Set limit to 8V
	12	Set limit to 12V
	16	Set limit to 16V
	20	Set limit to 20V
	24	Set limit to 24V
	32	Set limit to 32V
	33 to 42	Set limit to NONE
	DEFault	Set limit to 42V (NONE)
	MINimum	Set limit to 4V
	MAXimum	Set limit to 42V (NONE)
Query	[:LIMit]?	Query limit level
	[:LIMit]? DEFault	Query *RST default limit
	[:LIMit]? MINimum	Query lowest allowable limit
	[:LIMit]? MAXimum	Query highest allowable limit
Description	<p>This command is used to set the Over Voltage Protection (OVP) limit for the V-Source. The V-Source output will not exceed the selected limit. An exception to this is a parameter value that exceeds 160V for the Model 2400, 500V for the Model 2410, 48V for the Model 2420, 80V for the Models 2425 and 2430, or 32V for the Model 2440. Exceeding those values allows the V-Source to output its maximum voltage. The OVP limit is also enforced when in the I-Source Mode. The limit parameter values are magnitudes and are in effect for both positive and negative output voltage. You can express the limit as a positive or negative value.</p> <p>If you specify a value that is less than the lowest limit, the lowest limit will be selected. If you specify a value that is between limits, the lower limit will be selected. For example, if you specify a value of 110 for the Model 2400, the 100V limit will be selected.</p>	

WARNING Even with the voltage protection limit set to the lowest value (20V), NEVER touch anything connected to the terminals of the SourceMeter when the OUTPUT is ON. Always assume that a hazardous voltage (>30V rms) is present when the OUTPUT is ON.

To prevent damage to DUT (devices-under-test) or external circuitry, DO NOT program the V-Source to levels that exceed the voltage protection limit.

Set delay

NOTE For the Model 2430 Pulse Mode, source delay is not used. Therefore, the following commands for source delay are ignored.

DElAy <n>

	:SOURce[1]:DElAy <n>		Manually set source delay
Parameters	<n> =	0 to 999.9999 MINimum MAXimum DEFault	Specify delay in seconds 0 seconds 999.9999 seconds 0 seconds
Query	:DElAy?		Query delay
	:DElAy? DEFault		Query *RST default delay
	:DElAy? MINimum		Query lowest allowable delay
	:DElAy? MAXimum		Query highest allowable delay
Description	<p>This command is used to manually set a delay (settling time) for the source. After the programmed source is turned on, this delay occurs to allow the source level to settle before a measurement is taken. Note that this delay is the same for both the I-Source and V-Source. Do not confuse this source delay with the trigger delay. The source delay is part of the device action (SDM cycle) while the trigger delay occurs before the device action. See Section 11, “Trigger models,” for more information.</p> <p>Auto delay can instead be used to automatically set the source delay. (See next command.)</p>		

AUTO

	:SOURce[1]:DElAy:AUTO 		Enable/disable auto delay for source
Parameters	 =	0 or OFF 1 or ON	Disable auto delay Enable auto delay
Query	:AUTO?		Query state of auto delay
Description	<p>This command is used to enable or disable auto delay. When enabled, the instrument will automatically select a delay period that is appropriate for the present source/measure setup configuration (Table 3-4). *RST and SYST:PRES default is ON.</p>		

Configure voltage and current sweeps

There are two methods to configure the start and stop levels of a sweep. You can use either the :START and :STOP commands or you can use the :CENTER and :SPAN commands.

NOTE *In order to run a sweep, the selected source must be in the sweep sourcing mode and the trigger count should be the same as the number of source-measure points in the sweep.*

Use the :FUNCTION:MODE command to select the current or voltage source function. (See [“Select function modes,” page 18-72.](#)) Use the :CURRENT:MODE or VOLTAGE:MODE command to select the SWEEP sourcing mode. (See [“Select sourcing mode,” page 18-73.](#)) The trigger count is set using the TRIGGER:COUNT command. (See [“TRIGGER subsystem,” page 18-116.](#))

RANGing <name>

	:SOURCE[1]:SWEep:RANGing <name>	Select source ranging mode
Parameters	<name> = BEST AUTO FIXed	Use the best fixed mode Use the most sensitive source range for each sweep level Use the present source range for the entire sweep
Query	:RANGing?	Query source ranging mode
Description	<p>This command is used to select the source ranging mode for sweeps. With BEST selected, the SourceMeter will select a single fixed source range that will accommodate all the source levels in the sweep. For front panel operation, this is the BEST FIXED option.</p> <p>With AUTO selected, the SourceMeter will automatically go to the most sensitive source range for each source level in the sweep. For front panel operation, this is the AUTO RANGE option.</p> <p>With FIXed selected, the source remains on the range that it is presently on when the sweep is started. For sweep points that exceed the source range capability, the source will output the maximum level for that range. For front panel operation, this is the FIXED option.</p>	

SPACing <name>

	:SOURCE[1]:SWEep:SPACing <name>	Select scale for sweep
Parameters	<name> = LINear LOGarithmic	Linear scale Logarithmic scale
Query	:SPACing?	Query scale for sweep
Description	<p>This command is used to select the scale for the sweep. With LINear selected, the source-measure points in the sweep will be performed</p>	

on a linear scale. With LOGarithmic selected, the source-measure points will be performed on a logarithmic scale.

START <n>**STOP <n>**

:SOURce[1]:CURRent:START <n>	Specify start current level (current sweep)
:SOURce[1]:VOLTage:START <n>	Specify start voltage level (voltage sweep)
:SOURce[1]:CURRent:STOP <n>	Specify stop current level (current sweep)
:SOURce[1]:VOLTage:STOP <n>	Specify stop voltage level (voltage sweep)

Parameters**2400/2400-LV/2401**

<n> =	-1.05 to 1.05	Set I-Source level (amps)
	-210 to 210	Set V-Source level (volts)
		(-21 to 21, 2400-LV and 2401)
	DEFault	0A or 0V
	MINimum	-1.05A or -210V (-21V, 2400-LV and 2401)
	MAXimum	+1.05A or +210V (+21V, 2400-LV and 2401)

2410

<n> =	-1.05 to 1.05	Set I-Source level (amps)
	-1100 to 1100	Set V-Source level (volts)
	DEFault	0A or 0V
	MINimum	-1.05A or -1100V
	MAXimum	+1.05A or +1100V

2420

<n> =	-3.15 to 3.15	Set I-Source level (amps)
	-63 to 63	Set V-Source level (volts)
	DEFault	0A or 0V
	MINimum	-3.15A or -63V
	MAXimum	+3.15A or +63V

2425 and 2430 DC Mode

<n> =	-3.15 to 3.15	Set I-Source level (amps)
	-105 to 105	Set V-Source level (volts)
	DEFault	0A or 0V
	MINimum	-3.15A or -105V
	MAXimum	+3.15A or +105V

2430 Pulse Mode

<n> =	-10.5 to 10.5	Set I-Source level (amps)
	-105 to 105	Set V-Source level (volts)
	DEFault	0A or 0V
	MINimum	-10.5A or -105V
	MAXimum	+10.5A or +105V

2440

<n> =	-5.25 to 5.25	Set I-Source level (amps)
	-42 to 42	Set V-Source level (volts)
	DEFault	0A or 0V
	MINimum	-5.25A or -42V
	MAXimum	+5.25A or +42V

Query	:START?	Query start level for sweep
	:START? DEFault	Query *RST default level
	:START? MINimum	Query lowest allowable level
	:START? MAXimum	Query highest allowable level
	:STOP?	Query start level for sweep
	:STOP? DEFault	Query *RST default level
	:STOP? MINimum	Query lowest allowable level
	:STOP? MAXimum	Query highest allowable level

Description These commands are used to specify the start and stop levels for a sweep. If using a fixed (manual) source range, the sweep will be performed using a source range that will accommodate all source values (Best Fixed Range). You can use source auto range if sweeping through one or more source ranges.

When the sweep is started, the source will output the specified start level and, after the delay period of the SDM cycle, a measurement is performed.

NOTE For the Model 2430 Pulse Mode, source delay is not used. The delays in a Pulse Mode sweep are pulse width and pulse delay. See [Section 5](#) and [Section 10](#) for details.

The sweep continues until the source outputs the specified stop level. At this level, the instrument again performs another measurement (after the SDM delay) and then stops the sweep.

The source-measure points in a sweep can be set by specifying a step size, or by specifying the number of source-measure points in the sweep. (Refer to "STEP <n>," [page 18-87](#), and "POINTs <n>," [page 18-89](#).)

:START and :STOP are coupled to :CENTer and :SPAN. Thus, when start and stop values are changed, the values for center and span are affected as follows:

$$\text{Center} = (\text{Start} + \text{Stop}) / 2$$

$$\text{Span} = \text{Stop} - \text{Start}$$

CENter <n>**SPAN <n>**

:SOURce[1]:CURRent:CENter <n>

Specify center point of current sweep

:SOURce[1]:VOLTage:CENter <n>

Specify center point of voltage sweep

:SOURce[1]:CURRent:SPAN <n>

Specify span of the current sweep

:SOURce[1]:VOLTage:SPAN <n>

Specify span of the voltage sweep

Parameters**2400/2400-LV/2401**<n> =
-2.1 to 2.1
-420 to 420Set I-Source level (amps)
Set V-Source level (volts)
(-42 to 42, 2400-LV and 2401)
0A or 0V
-2.1A or -420V (-42V, 2400-LV
and 2401)2400-LV and 2401)
+2.1A or +420V (+42V, 2400-LV)DEFault
MINimum

MAXimum

2410<n> =
-2.1 to 2.1
-2200 to 2200Set I-Source level (amps)
Set V-Source level (volts)DEFault
MINimum
MAXimum0A or 0V
-2.1A or -2200V
+2.1A or +2200V**2420**<n> =
-6.3 to 6.3
-128 to 128Set I-Source level (amps)
Set V-Source level (volts)DEFault
MINimum
MAXimum0A or 0V
-6.3A or -128V
+6.3A or +128V**2425 and 2430 DC Mode**<n> =
-6.3 to 6.3
-210 to 210Set I-Source level (amps)
Set V-Source level (volts)DEFault
MINimum
MAXimum0A or 0V
-6.3A or -210V
+6.3A or +210V**2430 Pulse Mode**<n> =
-21 to 21
-210 to 210Set I-Source level (amps)
Set V-Source level (volts)DEFault
MINimum
MAXimum0A or 0V
-21A or -210V
+21A or +210V**2440**<n> =
-10.5 to 10.5
-84 to 84Set I-Source level (amps)
Set V-Source level (volts)DEFault
MINimum
MAXimum0A or 0V
-10.5A or -42V
+10.5A or +42V

Query	:CENTer?	Query center point for sweep
	:CENTer? DEFault	Query *RST default level
	:CENTer? MINimum	Query lowest allowable level
	:CENTER? MAXimum	Query highest allowable level
	:SPAN?	Query span for sweep
	:SPAN? DEFault	Query *RST default level
	:SPAN? MINimum	Query lowest allowable level
	:SPAN? MAXimum	Query highest allowable level
Description	<p>A sweep can be configured by specifying center and span parameters. By specifying a center point, you can sweep through the operating point of a device. The span determines the sweep width with the operating point at the center of the sweep.</p> <p>For example, assume you are testing a device that operates at 10V, and you want to sweep from 8 to 12 volts. To do this, you would specify the center to be 10V and the span to be 4 volts (12 - 8). Use the :STEP or :POINTs command to specify the number of source-measure points in the sweep.</p> <p>:CENTer and :SPAN are coupled to :START and :STOP. Thus, when center and span values are changed, the values for start and stop are affected as follows:</p> <p>Start = Center - (Span / 2) Stop = Center + (Span / 2)</p>	

STEP <n>

:SOURce[1]:CURRent:STEP <n> Specify step size (current sweep)
 :SOURce[1]:VOLTage:STEP <n> Specify step size (voltage sweep)

Parameters 2400/2400-LV/2401

<n> =	-2.1 to 2.1	Set I-Source level (amps)
	-420 to 420	Set V-Source level (volts) (-42 to 42, 2400-LV and 2401)
	DEFault	0A or 0V
	MINimum	-2.1A or -420V (-42V, 2400-LV and 2401)
	MAXimum	+2.1A or +420V (+42V, 2400-LV and 2401)

2410

<n> =	-2.1 to 2.1	Set I-Source level (amps)
	-2200 to 2200	Set V-Source level (volts)
	DEFault	0A or 0V
	MINimum	-2.1A or -2200V
	MAXimum	+2.1A or +2200V

2420

<n> =	-6.3 to 6.3	Set I-Source level (amps)
	-128 to 128	Set V-Source level (volts)
	DEFault	0A or 0V
	MINimum	-6.3A or -128V
	MAXimum	+6.3A or +128V

2425 and 2430 DC Mode

<n> =	-6.3 to 6.3	Set I-Source level (amps)
	-210 to 210	Set V-Source level (volts)
	DEFault	0A or 0V
	MINimum	-6.3A or -210V
	MAXimum	+6.3A or +210V

2430 Pulse Mode

<n> =	-21 to 21	Set I-Source level (amps)
	-210 to 210	Set V-Source level (volts)
	DEFault	0A or 0V
	MINimum	-21A or -210V
	MAXimum	+21A or +210V

2440

<n> =	-10.5 to 10.5	Set I-Source level (amps)
	-42 to 42	Set V-Source level (volts)
	DEFault	0A or 0V
	MINimum	-10.5A or -84V
	MAXimum	+10.5A or +84V

Query	:STEP	Query step size for sweep
	:STEP? DEFault	Query *RST default level
	:STEP? MINimum	Query lowest allowable level
	:STEP? MAXimum	Query highest allowable level

Description This command is used to specify a step size for a linear sweep. When the sweep is started, the source level changes in equal steps from the start level to the stop level. A measurement is performed at each source step (including the start and stop levels).

NOTE *This command cannot be used for a logarithmic sweep. Use the :POINTS command to set the source-measure points for a log sweep.*

To avoid a setting conflicts error, make sure the step size is greater than the start value and less than the stop value.

The number of source-measure points in a linear sweep can be calculated as follows:

$$\text{Points} = [(\text{Stop} - \text{Start}) / \text{Step}] + 1 |$$

$$\text{Points} = (\text{Span} / \text{Step}) + 1$$

An alternate way to set the source-measure points in a linear sweep is to simply specify the number of source-measure points in the sweep using the :POINTS command.

Note that the :STEP and :POINTS commands are coupled. Changing the step size also changes the number of source-measure points. Conversely, changing the number of source-measure points changes the step size.

POINTS <n>

	:SOURce[1]:SWEep:POINTS <n>	Set source-measure points for sweep
Parameters	<n> = 1 to 2500	Specify number of source-measure points
	MINimum	1
	MAXimum	2500
	DEFault	2500
Query	:POINTS?	Query number of sweep points
	:POINTS? DEFault	Query *RST default number of sweep points
	:POINTS? MINimum	Query lowest allowable number of sweep points
	:POINTS? MAXimum	Query highest allowable number of sweep points
Description	<p>The :POINTS command specifies the total number of source-measure points in a sweep. For a linear sweep, the source-measure points are equally spaced (stepped) between the start level and the stop level. For a log sweep, the source-measure points are equally spaced on a logarithmic scale. Note that the start and stop levels are source-measure points.</p> <p>Step size for a linear sweep can be calculated as follows:</p> $\text{Step Size} = (\text{Stop} - \text{Start}) / (\text{Points} - 1)$ $\text{Step Size} = \text{Span} / (\text{Points} - 1)$ <p>Step size for a logarithmic sweep can be calculated as follows:</p> $\text{Log Step Size} = \frac{\log_{10}(\text{Stop}) - \log_{10}(\text{Start})}{\text{Points} - 1}$ <p>An alternate way to set the source-measure points in a sweep is to specify the step size using the :STEP command.</p> <p>Note that the :POINTS and :STEP commands are coupled. Changing the number of source-measure points also changes the step size. Conversely, changing the step size changes the number of source-measure points.</p>	

DIRection <name>

	:SOURce[1]:SWEep:DIRection <name>	Set direction of sweep
Parameters	<name> = UP DOWN	Run sweep from start to stop Run sweep from stop to start
Query	:DIRection?	Query direction of sweep
Description	<p>Normally, a sweep is run from the start level to the stop level. The :START and :STOP, or :CENTER and :SPAN commands are used to set these levels.</p> <p>This command lets you change the execution direction of the sweep. With DOWN selected, the sweep will begin at the stop level and end at the start level. Selecting UP restores sweep operation to the normal start to stop direction.</p>	

Abort on compliance**CABort <name>**

	:SOURce[1]:SWEep:CABort <name>	Control abort on compliance
Parameters	<name> = NEVER EARLY LATE	Disable abort on compliance Abort at start of SDM cycle Abort at end of SDM cycle
Query	:CABort?	Query abort on compliance
Description	<p>This feature aborts a sweep in progress if compliance is detected. There are three modes: NEVER, EARLY, and LATE. NEVER turns off the feature, EARLY will abort when compliance is detected at the beginning of the SDM cycle, and LATE aborts if the compliance is detected at the end of the SDM cycle.</p>	

Configure list

CURRent <NRf list>

VOLTage <NRf list>

:SOURce[1]:LIST:CURRent <NRf list>

Define I-Source list

:SOURce[1]:LIST:VOLTage <NRf list>

Define V-Source list

Parameters <NRf list> = NRf, NRf ... NRf

2400/2400-LV/2401

NRf =	-1.05 to 1.05	I-Source value
	-210 to 210	V-Source value (-21 to 21, 2400-LV and 2401)

2410

NRf =	-1.05 to 1.05	I-Source value
	-1100 to 1100	V-Source value

2420

NRf =	-3.15 to 3.15	I-Source value
	-63 to 63	V-Source value

2425 and 2430 DC Mode

NRf =	-3.15 to 3.15	I-Source value
	-105 to 105	V-Source value

2430 Pulse Mode

NRf =	-10.5 to 10.5	I-Source value
	-105 to 105	V-Source value

2440

NRf =	-5.25 to 5.25	I-Source value
	-42 to 42	V-Source value

Query	:CURRent?	Query I-Source list
	:VOLTage?	Query V-Source list

Description These commands are used to define a list of source values (up to 100) for the list sourcing mode of operation. When operation is started, the instrument will sequentially source each current or voltage value in the list. A measurement is performed at each source level.

The following command shows the proper format for defining an I-Source list using current source values of 10mA, 130mA and 5mA:

```
:SOURce[1]:LIST:CURRent 0.01, 0.13, 0.005
```

If using manual source ranging, you can use auto range for source values that are not within a single range.

NOTE *In order to execute a source list, the selected source must be in the list sourcing mode, and the product of the arm and trigger count should be at least the same as the number of source points in the list.*

Use the :FUNCTION:MODE command to select the current or voltage source function. (See “[Select function modes](#),” page 18-72.) Use the :CURRENT:MODE or VOLTAGE:MODE command to select the LIST sourcing mode. (See “[Select sourcing mode](#),” page 18-73.) The trigger count is set using the TRIGGER:COUNT command. (See “[TRIGGER subsystem](#),” page 18-116.)

APPend <NRf list>

:SOURCE[1]:LIST:CURRENT:APPend <NRf list>

Add value(s) to I-Source list

:SOURCE[1]:LIST:VOLTage:APPend <NRf list>

Add value(s) to V-Source list

Parameters <NRf list> = NRf, NRf ... NRf

2400/2400-LV/2401

NRf = -1.05 to 1.05 I-Source value
 -210 to 210 V-Source value (-21 to 21,
 2400-LV and 2401)

2410

NRf = -1.05 to 1.05 I-Source value
 -1100 to 1100 V-Source value

2420

NRf = -3.15 to 3.15 I-Source value
 -63 to 63 V-Source value

2425 and 2430 DC Mode

NRf = -3.15 to 3.15 I-Source value
 -105 to 105 V-Source value

2430 Pulse Mode

NRf = -10.5 to 10.5 I-Source value
 -105 to 105 V-Source value

2440

NRf = -5.25 to 5.25 I-Source value
 -42 to 42 V-Source value

Description This command is used to add one or more values (up to 100) to a source list that already exists. The source values are appended to the end of the list. (By using multiple appended lists, up to 2500 points can be in a list.)

POINTs?

:SOURCE[1]:LIST:CURRENT:POINTs?

Query length of I-Source list

:SOURCE[1]:LIST:VOLTage:POINTs?

Query length of V-Source list

Description This command is used to determine the length of the specified source list. The response message indicates the number of source values in the list.

START <n>

:SOURce[1]:LIST:CURRent:START <n> Set current list start point
 :SOURce[1]:LIST:VOLTaget:START <n> Set voltage list start point

Parameters	<n> =	1 to 100	Set start point of list sweep
		MINimum	1
		MAXimum	100
		DEFault	1

Description These commands set the starting point in the current or voltage list sweep. The <n> parameter is 1-based, and it must be less than or equal to the number of points in the sweep. The new starting location will only be used when the direction of the sweep is up (:SOUR:LIST:CURR:DIR UP, for example). Changing the direction to down will make the sweep start at the last point in the list, but the starting point will be restored when the direction is changed to up. If the sweep reaches the end of the list, the sweep will continue from the first point in the list. The starting points for voltage and current sweeps are saved separately, and are part of a user-saved setup.

Configure memory sweep

A memory sweep lets you perform a sweep using setups stored in up to 100 memory locations. This allows you to sweep using multiple source-measure operations and math expressions. (See “CALCulate[1],” page 18-26, subsystem.)

NOTE *In order to run a memory sweep, the memory function must be selected, and the trigger count must be the same as the number of memory points in the sweep. Use the :FUNCTION:MODE command to select the MEMory function. (See “Select function modes,” page 18-72.) Arm count (ARM:COUNT) and trigger count (TRIGGER:COUNT) are set from the Trigger Subsystem.*

When memory is initialized (:SYSTEM:MEMory:INITialize), all 100 memory locations for a memory sweep are initialized to the present setup configuration of the SourceMeter with CALC1 disabled. User-defined math expressions are replaced with the Power math expression.

Error 809 (Source memory location revised) occurs when a memory sweep references an expression that no longer exists. The memory sweep is revised to disable CALC1.

In order to execute a memory sweep, the product of the arm count and trigger count should be at least the same as the number of points in the sweep.

Use the :FUNCTION:MODE command to select the MEMory function. (See “Select function modes,” page 18-72.) Arm count (ARM:COUNT) and trigger count (TRIGGER:COUNT) are set from the Trigger Subsystem.

SAVE <Nrf>

:SOURce[1]:MEMory:SAVE <Nrf> Save setup in specified memory location

Parameters <Nrf> = 1 to 100 Specify memory location

Description This command is used to save the present instrument setup in a memory location. Up to 100 setups can be saved. The following settings are saved in each source memory location:

SENSE[1]:CURRent:NPLCycles
 SENSE[1]:RESistance:NPLCycles
 SENSE[1]:VOLTagE:NPLCycles
 SENSE[1]:FUNctIon:CONCurrent
 SENSE[1]:FUNctIon:ON
 SENSE[1]:FUNctIon:OFF
 SENSE[1]:RESistance:MODE
 SENSE[1]:RESistance:OCOMpensated
 SENSE[1]:AVERage:STATe
 SENSE[1]:AVERage:TCONtroll
 SENSE[1]:AVERage:COUNT
 SOURce[1]:FUNctIon:SHAPE (Model 2430 only)
 SOURce[1]:FUNctIon:MODE
 SOURce[1]:DELay (Model 2430 in DC Mode)
 SOURce[1]:DELay:AUTO (Model 2430 in DC Mode)
 SOURce[1]...X...:TRIGgered:SFACTor
 SOURce[1]...X...:TRIGgered:SFACTor:STATe
 where: ...X... = :CURRent or :VOLTagE (based on source mode)
 SOURce[1]:PULSe:WIDTh (Model 2430 Pulse Mode only)
 SOURce[1]:PULSe:DELay (Model 2430 Pulse Mode only)
 Source Value, Range, Auto Range
 Sense Protection, Range, Auto Range
 SYSTem:AZERo:STATe
 SYSTem:GUARd
 SYSTem:RSENse
 ROUTe:TERMinals
 CALCulate1:STATe
 CALCulate1:MATH[:EXPRession]:NAME
 CALCulate2:FEED
 CALCulate2:NULL:OFFSet
 CALCulate2:NULL:STATe
 CALCulate2:LIMit[1]:STATe
 CALCulate2:LIMit[1]:COMPLiance:FAIL
 CALCulate2:LIMit[1]:COMPLiance:SOURce2

 CALCulate2:LIMitX:STATe
 CALCulate2:LIMitX:UPPer[:DATA]
 CALCulate2:LIMitX:UPPer:SOURce2
 CALCulate2:LIMitX:LOWer[:DATA]
 CALCulate2:LIMitX:LOWer:SOURce2
 CALCulate2:LIMitX:PASS:SOURce2

where: X = 2, 3 and 5 through 12

CALCulate2:CLIMits:PASS:SOURce2
 CALCulate2:CLIMits:PASS:SMLocation
 TRIGger:DELay (Model 2430 in DC Mode)
 Contact check commands ([Appendix F](#))

After saving the desired setups in consecutive memory locations (unless branching, see CALC2:CLIM:PASS:SML), use the :POINTS command to specify how many sweep points to perform and the :START command to specify where to start from.

POINTS <NRf>

:SOURCE:MEMORY:POINTS <NRf> Specify number of sweep points to execute

Parameters <NRf> = 1 to 100 Number of sweep points

Description This command is used to specify the number of points for the sweep. For example, if you saved setups in memory locations 1 through 12 for a sweep, specify a 12-point sweep using this command.

START <NRf>

:SOURCE:MEMORY:START <NRf> Select Source Memory Sweep start location

Parameters <NRf> = 1 to 100 Specify memory location

Description This command is used to set the starting location of a Source Memory Sweep. For example, for setups saved in memory locations 98 through 5, specify a starting location of 98.

RECall <NRf>

:SOURCE:MEMORY:RECall <NRf> Return to specified setup

Parameters <NRf> = 1 to 100 Specify memory location

Description This command is used to return the SourceMeter to the setup stored at the specified memory location.

Set scaling factor

TRIGgered:SFACTOR <n>

:SOURCE[1]:CURRENT[:LEVEL]:TRIGgered:SFACTOR <n> Set current scaling factor

:SOURCE[1]:VOLTage[:LEVEL]:TRIGgered:SFACTOR <n> Set voltage scaling factor

Parameters <n> = -999.9999e+18 to 999.9999e+18 Scaling factor

Query :SFACTOR? Query scaling factor

Description :SFAC instructs the SourceMeter to source the scaling factor times the previous source memory location value. For example, if 10.0V is stored in the first source memory (Source I, Measure V Mode), and the unit is in the Source V, Measure I mode with :SFAC set to 0.1 and enabled, the unit will output 1.0V for the second source memory location.

NOTE These commands work only with source memory sweeps.

TRIGgered:SFACtor:STATe

:SOURce[1]:CURRent[:LEVel]:TRIGgered:SFACtor:STATe Enable/disable current scaling
 :SOURce[1]:VOLTag[:LEVel]:TRIGgered:SFACtor:STATe Enable/disable voltage scaling

Parameters = 1 or ON Enable scaling
 0 or OFF Disable scaling

Query :SFACtor:STATe? Query enabled/disabled scaling state

Description :SFAC:STAT enables or disables scaling.

NOTE These commands work only with source memory sweeps.

Soak time

SOAK <NRf>

:SOURce[1]:SOAK <NRf> Set multiple mode soak time

Parameters <NRf> = soak time (s) 0.000 to 9999.999s

Query :SOAK? Query multiple mode soak time

Description With SYST:RCMode set to MULTiple, SOUR:SOAK specifies the amount of time after the first point of a sweep that the unit will sit in a loop actively autoranging up and down to allow a multiple SourceMeter configuration to settle. (See “[SYSTEM subsystem](#),” page 18-103.) This process will be done only once per INIT, READ?, or MEAS? command. The soak time is especially useful for low current measurements when multiple down-range changes from the higher ranges are required.

NOTE For the Model 2430 Pulse Mode, soak time is not used for sweeps.

Pulse Mode delays (Model 2430 only)

WIDTH <n>

:SOURce[1]:PULSe:WIDTh <n>

Specify pulse width

Parameters <n> = 0.00015 to 0.00500 Specify pulse width in seconds

 MINimum 0.00015 seconds

 MAXimum 0.00500 seconds

 DEFault 0.00015 seconds

Query :WIDTh? Query pulse width
 :WIDTh? DEFault Query *RST default pulse width
 :WIDTh? MINimum Query lowest allowable pulse width
 :WIDTh? MAXimum Query highest allowable pulse width

Description This command is used to set the pulse width for the Model 2430 Pulse Mode. The pulse width is the time that the output remains on, including the signal measurement.

The valid range of pulse width periods is from 0.15ms to 5ms. The pulse width can be set to <0.15ms, however, 0.15ms is the minimum pulse width that will occur. On the 10A range (source or measure), the pulse width can be set up to 5ms, however, it will be limited to 2.5ms.

NOTE See [Section 5](#) for details on Model 2430 Pulse Mode.

DELay <n>

:SOURce[1]:PULSe:DELay <n>

Specify pulse delay

Parameters <n> = 0 to 9999.99900 Specify pulse delay in seconds

 MINimum 0 seconds

 MAXimum 9999.999 seconds

 DEFault 0 seconds

Query :DELay? Query pulse width
 :DELay? DEFault Query *RST default pulse width
 :DELay? MINimum Query lowest allowable pulse width
 :DELay? MAXimum Query highest allowable pulse width

Description This command is used to set the pulse delay for the Model 2430 Pulse Mode. The pulse delay occurs during the off-time of the pulse period, and is used to adjust the duty cycle.

NOTE See [Section 5](#) for details on Model 2430 Pulse Mode.

SOURce2

The following commands are used to set the logic level of the digital output lines and control the pulse width of limit test output patterns that are sent to component handlers. Limit tests are configured and controlled from the CALCulate2 Subsystem. For details on limit testing, see [Section 12](#), “Limit Testing.”

NOTE All the SOURce2 commands are invalid for the Model 2401 and will cause undefined header errors.

Setting digital output

[[:LEVel] <NRf> | <NDN>

:SOURce2:TTL:[LEVel] [:DEFault] <NRf> | <NDN>

Set digital output pattern

:SOURce2:TTL:[LEVel]:ACTual?

Query actual output pattern

Parameters <NRf> | <NDN> = 0 to 7, 3-bit Specify digital output value
0 to 15, 4-bit

Query :TTL? Query default digital output value
:ACTual? Query actual digital output value

Description This command is used to set the logic levels of the output lines of the Digital I/O port. When set high, the specified output line will be at approximately +5V. When set low, the output line will be at 0V. Use the following table to determine the parameter value for the desired decimal digital output pattern:

OUT 4	OUT 3	OUT 2	OUT 1	Decimal value*
L	L	L	L	0
L	L	L	H	1
L	L	H	L	2
L	L	H	H	3
L	H	L	L	4
L	H	L	H	5
L	H	H	L	6
L	H	H	H	7
H	L	L	L	8
H	L	L	H	9
H	L	H	L	10
H	L	H	H	11
H	H	L	L	12
H	H	L	H	13
H	H	H	L	14
H	H	H	H	15

L = Low (Gnd), H = High (>+3V)

* 0-7 in 3-bit mode, 0 to 65535 with 2499-DIGIO option.

MODE <name>

	:SOURce2:TTL4:MODE <name>	Control Digital I/O port line 4 mode
Parameters	<name> = EOTest BUSY	Use line 4 as EOT signal Use line 4 as BUSY signal
Query	:MODE?	Query Digital I/O line 4 mode
Description	This command controls the operation of Digital I/O line 4 to act as either an End-of-Test or Busy signal in the 3-bit output mode. EOT is not automatically controlled in 4-bit mode. (See “BSIZe <n>,” page 18-99 .) Likewise, with BUSY enabled in the 4-bit mode, the unit behaves if it were in 3-bit mode by ignoring all attempts to drive Digital I/O line 4.	

**BSTate **

	:SOURce2:TTL4:BSTate 	Control BUSY and EOT polarity
Parameters	 = 1 0	Set EOT/BUSY polarity high Set EOT/BUSY polarity low
Query	:BSTate?	Query EOT/BUSY polarity
Description	This command sets the polarity of the EOT or BUSY signal in the 3-bit mode.	

BSIZe <n>

	:SOURce2:BSIZe <n>	Set Digital I/O bit size
Parameters	<n> = 3 4	Set 3-bit size Set 4-bit size
Query	:BSIZe?	Query Digital I/O port bit size
Description	This command sets the Digital I/O bit size to 3 or 4. In the 3-bit mode, Digital I/O line 4 becomes EOT, /EOT, BUSY, or /BUSY based on the SOUR2:TTL4:MODE and SOUR2:TTL4:BST commands above. In 4-bit mode, Digital I/O line 4 is controlled manually if SOUR2:TTL4:MODE is set to EOT. If SOUR2:TTL4:MODE is set to BUSY, operation is identical to the 3-bit mode. 16-bit size is available with the 2499-DIGIO option.	

Clearing digital output**[:IMMEDIATE]**

	:SOURce2:CLEar[:IMMEDIATE]	Clear digital output lines
Description	This action command is used to immediately restore the digital output lines to the output pattern defined by the :TTL:LEVel command.	

**AUTO **

	:SOURce2:CLEar:AUTO 	Control auto-clear for digital output
Parameters	 = 0 or OFF 1 or ON	Disable auto-clear Enable auto-clear
Query	:AUTO?	Query auto-clear
Description	<p>This command is used to enable or disable auto-clear for the digital output lines. When enabled, the output pattern will clear automatically after the “pass or fail” output bit pattern of a limit test is sent to a handler via the digital output lines.</p> <p>The :DELay command specifies the pulse width of the limit test bit pattern. (See next command.) After the delay period times out, the digital output clears back to the output pattern programmed by the :TTL:LEVel command.</p> <p>When auto-clear is disabled, the digital output pattern can only be cleared by the :IMMediate command.</p> <p>On power-up, auto clear is enabled.</p> <p>See “CALCulate2” subsystem and Section 12, “Limit Testing,” for details on limit tests.</p>	

DELay <n>

	:SOURce2:CLEar:AUTO:DELay <n>	Set delay for auto-clear
Parameters	<n> = 0 to 60 DEFault MINimum MAXimum	Specify delay (in seconds) 100µsec delay 0 sec 60 sec
Query	:DELay? :DELay? DEFault :DELay? MINimum :DELay? MAXimum	Query delay Query *RST default delay Query lowest allowable delay Query maximum allowable delay
Description	<p>This command is used to set the delay for digital output auto-clear. This delay determines the pulse width of the limit test output pattern as required by the handler. After the delay, the output returns (clears) to the pattern programmed by the :TTL:LEVel command.</p> <p>The delay actually defines the pulse width for line 4, which is used by category register component handlers as the end-of-test (EOT) strobe. The pulse width of the other three lines are 20µsec longer (10µsec before line 4 is toggled, and 10µsec after line 4 is cleared). Skewing the timing on line 4 provides setup and hold time for category register component handlers. See Section 12, “Limit Testing,” for details on timing.</p>	

STATus subsystem

The STATus subsystem is used to control the status registers of the SourceMeter. The commands in this subsystem are summarized in [Table 18-8](#).

NOTE These registers and the overall status structure are fully explained in [Section 15, “Status Structure.”](#)

Read event registers

[[:EVENT]?

:STATus:MEASurement[:EVENT]?	Read Measurement Event Register
:STATus:QUESTionable[:EVENT]?	Read Questionable Event Register
:STATus:OPERation[:EVENT]?	Read Operation Event Register

Description These query commands are used to read the contents of the status event registers. After sending one of these commands and addressing the SourceMeter to talk, a value is sent to the computer. This value indicates which bits in the appropriate register are set.

Program event enable registers

ENABle <NDN> or <NRf>

:STATus:MEASurement:ENABle <NDN> or <NRf>	Program Measurement Event Enable Register
:STATus:QUESTionable:ENABle <NDN> or <NRf>	Program Questionable Event Enable Register
:STATus:OPERation:ENABle <NDN> or <NRf>	Program Operation Event Enable Register

Description These commands are used to set the contents of the event enable registers.

Read condition registers

CONDition?

:STATus:MEASurement:CONDition?	Read Measurement Condition
:STATus:QUESTionable:CONDition?	Read Questionable Register
:STATus:OPERation:CONDition?	Read Operation Condition

Description These query commands are used to read the contents of the condition registers.

Select default conditions

PRESet

:STATus:PRESet Return registers to default conditions

Description When this command is sent, the following SCPI event registers are cleared to zero (0):

1. Operation Event Enable Register.
2. Event Enable Register.
3. Measurement Event Enable Register.

NOTE The Standard Event Register is not affected by this command.

Error queue

[:NEXT]?

:STATus:QUEue[:NEXT]? Read Error Queue

Description As error and status messages occur, they are placed into the Error Queue. This query command is used to read those messages. See [Appendix B](#) for a list of messages.

NOTE The :STATus:QUEue[:NEXT]? query command performs the same function as the :SYSTem:ERRor? query command. (See [“SYSTem subsystem,” page 18-103.](#))

CLEAr

:STATus:QUEue:CLEAr Clear Error Queue

Description This action command is used to clear the Error Queue of messages.

ENABle <list>

:STATus:QUEue:ENABle <list> Enable messages for Error Queue

Parameters <list> = (numlist)
where numlist is a specified list of messages that you wish to enable for the Error.

Query :ENABle? Query list of enabled messages

Description On power-up, all error messages are enabled and will go into the Error Queue as they occur. Status messages are not enabled and will not go into the queue. This command is used to specify which messages you want enabled. Messages not specified will be disabled and prevented from entering the queue.

DISable <list>

:STATus:QUEue:DISable <list>

Disable messages for Error Queue

Parameters <list> = (numlist)

where numlist is a specified list of messages that you wish to disable for the Error Queue.

Query :DISable?

Query list of disabled messages

Description

On power-up, all error messages are enabled and will go into the Error Queue as they occur. Status messages are not enabled and will not go into the queue. This command is used to specify which messages you want disabled. Disabled messages are prevented from going into the Error Queue.

SYSTem subsystem

The SYSTem subsystem contains miscellaneous commands that are summarized in [Table 18-9](#), SYSTem command summary.

Default conditions

PRESet

:SYSTem:PRESet

Return to :SYSTem:PRESet defaults

DescriptionThis command returns the instrument to states optimized for front panel operation. :SYSTem:PRESet defaults are listed in the SCPI tables ([Table 18-1](#) through [Table 18-11](#)).**POSetup**

:SYSTem:POSetup <name>

Program power-on defaults

Parameters

<name> = RST	Power-up to *RST defaults
PRESet	Power-up to :SYSTem:PRESet defaults
SAV0	Power-up to setup stored at memory location 0
SAV1	Power-up to setup stored at memory location 1
SAV2	Power-up to setup stored at memory location 2
SAV3	Power-up to setup stored at memory location 3
SAV4	Power-up to setup stored at memory location 4

Query

:POSetup?

Query power-on setup

Description This command is used to select the power-on defaults. With RST selected, the instrument powers up to the *RST default conditions. With PRES selected, the instrument powers up to the :SYSTem:PRE-Set default conditions. Default conditions are listed in the SCPI tables (Table 18-1 through Table 18-11).
With the SAV0-4 parameters specified, the instrument powers-on to the setup that is saved in the specified location using the *SAV command.

Control remote sensing

CCHeck

:SYSTem:CCHeck Enable or disable contact check.

Parameters = 0 or OFF Disable contact check
1 or ON Enable contact check

Query CCHeck? Query state of contact check

Description This command is used to enable or disable contact check. When using contact check, remote sensing must be enabled (:SYST:RSEN ON).

RESistance <NRf>

:SYSTem:CCHeck:RESistance <NRf> Set contact check threshold resistance.

Parameters <NRf>= 0- 60 ohms (2 ohms, 15 ohms, or 50 ohms threshold resistance)
0 to 2 = 2 ohms
2 to 15 = 15ohms
15 to 60 = 50 ohms

Query RESistance? Query contact check threshold resistance.

Description This command sets the contact threshold resistance value. (Factory default = 50 ohms.) The contact check function will indicate a failure when the connection path resistance is greater than the programmed value. This command is used to enable or disable contact check. When using contact check, remote sensing must be enabled (:SYST:RSEN ON).

RSENse

:SYSTem:RSENse Enable or disable remote sensing.

Parameters = 0 or OFF Disable remote sensing
1 or ON Enable remote sensing

Query :RSENse? Query state of remote sensing

Description	<p>This command is used to enable or disable remote sensing. When using remote sensing, 4-wire connections to the DUT are required.</p> <p>Sourcing voltage — With remote sensing enabled, the output voltage is sensed (measured) at the DUT. If the sensed voltage is lower than the programmed amplitude, then the V-Source increases the voltage until the sensed voltage is the same as the programmed amplitude. This compensates for IR drop in the OUTPUT test leads. With remote sensing disabled, the output voltage is sensed at the output connectors.</p> <p>Measuring voltage — With remote sensing enabled, voltage measurements are made at DUT. This eliminates any voltage drops that may be in the test leads between the SourceMeter and the DUT. With remote sensing disabled, voltage measurements are performed at the output connectors of the instrument.</p> <p>Measuring resistance — With remote sensing enabled, 4-wire resistance measurements can be made.</p>
--------------------	--

NOTE See [Section 2](#) for details on sensing.

Select guard mode

GUARd <name>

:SYSTem:GUARd <name>

Select guard mode

Parameters	<name> =	OHMS	Ohms guard mode
		CABLE	Cable guard mode

Query	:GUARd?	Query guard mode
--------------	---------	------------------

Description This command is used to select the guard mode. OHMS guard is a low-impedance guard drive used for in-circuit resistance measurements. Ohms guard is not available for SourceMeters that have 1A, 3A and/or 10A ranges (source or measure). CABLE guard provides a high-impedance guard drive that is used to eliminate leakage currents in cabling and test fixtures.

When performing 6-wire ohms guard measurements, use the GUARd out-put state. The OUTPut [1]:SMODE GUARd command is used to select the GUARd output-off state.

NOTE See [Section 2](#) for details on guarding.

Initialize memory

INITialize

:SYSTem:MEMory:INITialize

Initializes battery backed RAM

Description When this command is used, the following actions to initialize battery backed RAM occur:

- TRACe (data store) data is lost, buffer size is reset to 100, and timestamp is set to the absolute format.
- SOURce1:LIST:CURR and VOLT are reset to 0A and 0V, respectively.
- Deletes all user-defined math expressions. (See “CALCulate[1]” subsystem.)
- All 100 memory locations for a memory sweep are initialized to the present setup configuration of the SourceMeter with CALC 1 disabled. User-defined math expressions are replaced with the “Power” math expression.
- The four standard save setups (*SAV0 - *SAV4) are initialized to the present setup configuration of the SourceMeter.
- All CALCulate1 user-defined math expressions are deleted.

Control beeper

[:IMMediate] <freq, time>

:SYSTem:BEEPer[:IMMediate] <freq, time>

Parameters	freq =	65 to 2e6	Specify frequency in Hz
	time =	0 to 7.9	Specify time duration

NOTE The frequency and time values must be separated by a comma (i.e., :syst:beep 100, 3).

Description The beeper of the SourceMeter can be used to provide an audible signal at a specified frequency and time duration (up to 7.9 seconds @ 65Hz). This beeper can, for example, be used to signal the end of a lengthy sweep.

Example: :SYSTem:BEEPer500, 1 Beep at 500Hz for 1 second

The correlation between the duration and frequency of the beep is expressed as follows:

Maximum Time = 512/ Frequency

For example, at a frequency of 512Hz, the maximum beep time is one second. You can set the time greater than one (1) second, but it will only beep for one second.

Note that in order to use this command, the beeper must be enabled. (See next command.)

**STATe **

	:SYSTem:BEEPer:STATe 	Enable or disable beeper
Parameters	 = 1 or ON 0 or OFF	Enable beeper Disable beeper
Query	:STATe?	Query state of beeper
Description	This command is used to enable or disable the beeper. When enabled, a short beep is provided to signal that a front panel key has been pressed.	

Control auto zero**STATe <name>**

	:SYSTem:AZERo:STATe <name>	Control auto zero
Parameters	<name> = ON OFF ONCE	Enable auto zero Disable auto zero Force immediate auto zero update
Query	:STATe?	Query state of auto zero
Description	This command is used to enable or disable auto zero, or to force an immediate one-time auto zero update if auto zero is disabled. When auto zero is enabled, accuracy is optimized. When auto zero is disabled, speed is increased at the expense of accuracy.	

Control NPLC caching**CACHing**

	:SYSTem:AZERo:CACHing[:STATe] 	Enable/disable NPLC caching
	:SYSTem:AZERo:CACHing:REFresh	Update NPLC cache values
	:SYSTem:AZERo:CACHing:RESet	Clear NPLC values from cache
	:SYSTem:AZERo:CACHing:NPLCycles?	Return list of NPLC values
Parameters	 = 1 or ON 0 or OFF	Enable NPLC caching Disable NPLC caching
Query	[:STATe]? :NPLCycles?	Query state of NPLC caching Return list of NPLC values stored in cache from oldest to newest.
Description	NPLC caching speeds up source memory sweeps by caching A/D reference and zero values. When SYST:AZER:CACH is enabled, the A/D reference and zero values will be saved for up to the 10 most recent [:SENSe[1]]:VOLTage[:DC]:NPLCycles, [:SENSe[1]]:CURRent[: DC]:NPLCycles, or [:SENSe[1]]:RESistance:NPLCycles settings. Whenever the integration rate is changed via an NPLC	

command, user setup recall (*RCL), or a source memory recall (:SOUR:MEM command or during a source memory sweep), NPLC caching will occur. If the integration rate is already stored in the cache, the stored reference and zero values are recalled and used. Otherwise, a reference and zero value are acquired and stored in the cache. If there are already 10 NPLC values stored, the oldest one will be overwritten by the newest one.

Follow these general steps to program and use NPLC caching:

1. Send this command to disable auto zero: SYST:AZER OFF.
2. Enable NPLC caching by sending: SYST:AZER:CACH ON.
3. Set up and run your source memory sweep with the :SOUR:MEM commands along with the various other commands required to program additional operating modes. (See [“Configure memory sweep,”](#) as well as other pertinent command descriptions in this section, for details.)

NOTE *Auto zero should be disabled with the :SYST:AZER OFF command for maximum source memory sweep speed; otherwise, the cache is of little use. With auto zero enabled, new A/D reference and zero values are taken for every reading and saved into the cache, slowing down sweep operation. However, with auto zero disabled, measurements may drift and become erroneous. To minimize drift when using NPLC caching with auto zero disabled, periodically send :SYST:AZER ONCE to force an immediate auto zero update.*

Select power line frequency setting

LFrequency <freq>

	:SYSTem:LFrequency <freq>	Select line frequency
Parameters	<freq> = 50 60	50Hz or 400Hz setting 60Hz setting
Query	:LFrequency?	Query line frequency selection.
Description	Use this command to manually select the line frequency setting (50 or 60Hz). For 400Hz operation, select 50Hz.	

AUTO

	:SYSTem:LFrequency:AUTO 	Control auto line frequency selection
Parameters	 = 1 or ON 0 or OFF	Enable and line frequency selection Disable auto line frequency selection
Query	:AUTO?	Query state of auto line frequency selection.
Description	This command is used to enable or disable auto line frequency detection. When enabled, the SourceMeter will sense the line frequency on power-up and select the appropriate line frequency setting. Manually setting the line frequency disables auto frequency. (See previous command.)	

Error queue

NOTE See [Section 15](#) for details on the error queue.

[:NEXT]?

:SYSTem:ERRor[:NEXT]? Read oldest error (code and message)

Description As error and status messages occur, they are placed in the Error Queue. The Error Queue is a first-in, first-out (FIFO) register that can hold up to 10 messages. After sending this command and addressing the SourceMeter to talk, the oldest message is sent to the computer and is then removed from the queue.

NOTE The `:STATus:Queue?` command performs the same function as `:SYSTem:ERRor[:NEXT]?`. (See [“STATus subsystem,” page 18-101.](#))

ALL?

:SYSTem:ERRor:ALL? Read all errors (codes and messages)

Description This query command is similar to the `[:NEXT]?` command except that all messages in the Error Queue are sent to the computer when the SourceMeter is addressed to talk. All messages are removed from the queue.

COUNT?

:SYSTem:ERRor:COUNT? Return the number of errors

Description After sending this command and addressing the SourceMeter to talk, a decimal number will be sent to the computer. That is the number of messages in the Error Queue.

CODE[:NEXT]?

:SYSTem:ERRor:CODE[:NEXT]? Read oldest error (code only)

Description This command is identical to the `[:NEXT]?` command, except only the code is returned. The message itself is not returned. The error is cleared from the queue.

CODE:ALL?

SYSTem:ERRor:CODE:ALL? Read all errors (codes only)

Description This query command is identical to the `:ALL?` command, except only the codes are returned. The actual messages are not returned. All errors are cleared from the queue.

CLEar

:SYSTem:CLEar Clear Error Queue

Description This action command is used to clear the Error Queue of messages.

Simulate key presses

KEY

:SYSTem:KEY <NRf>

Simulate key-press

Parameters	<NRf> =	1	RANGE up arrow key
		2	SOURCE down arrow key
		3	left arrow key
		4	MENU key
		5	FCTN key
		6	FILTER key
		7	SPEED key
		8	EDIT key
		9	AUTO key
		10	right arrow key
		11	EXIT key
		12	V (SOURCE) key
		13	LIMITS key
		14	STORE key
		15	V (MEAS) key
		16	TOGGLE key
		17	RANGE down arrow key
		18	ENTER key
		19	I (SOURCE) key
		20	TRIG key
		21	RECALL key
		22	I (MEAS) key
		23	LOCAL key
		24	ON/OFF key
		25	----
		26	SOURCE up arrow key
		27	SWEEP key
		28	CONFIG key
		29	Ω key
		30	REL key
		31	DIGITS key
		32	FRONT/REAR key

Query :KEY? Query last pressed key.

Description This command is used to simulate front panel key presses. For example, to select the voltage measurement function (V), you can send the following command to simulate pressing the V (MEAS) key:

```
:syst:key 15
```

The parameter listing provides the key-press code in numeric order. [Figure 18-3](#) also illustrates the key-press codes.

The queue for the :KEY? query command can only hold one key-press. When :KEY? is sent over the bus, and the SourceMeter is addressed to talk, the key-press code number for the last key pressed (either physically or with :KEY) is sent to the computer.

The key-press code number for the last key pressed (either physically or with :key) is sent to the computer.

Figure 18-3
Key-press codes

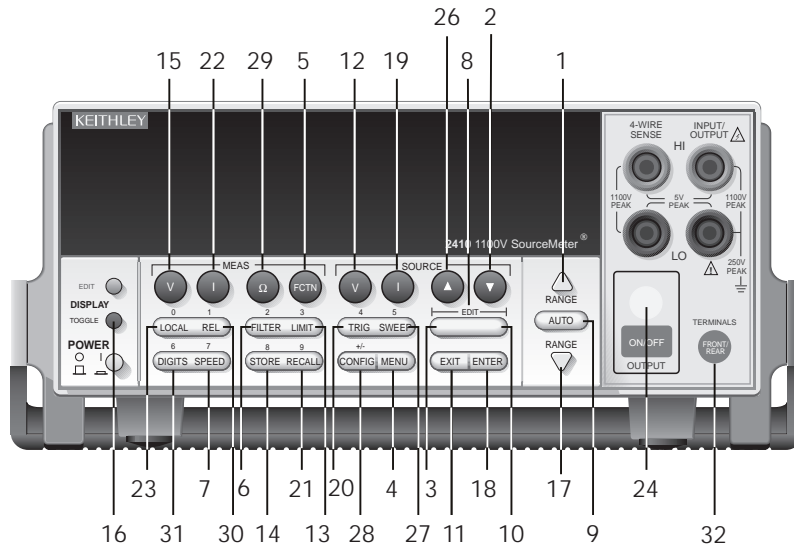

Parameters

<Nrf> =	1 RANGE up arrow key	17 RANGE down arrow key
	2 SOURCE down arrow key	18 ENTER key
	3 Left arrow key	19 I (SOURCE) key
	4 MENU key	20 TRIG key
	5 FCTN key	21 RECALL key
	6 FILTER key	22 I (MEAS) key
	7 SPEED key	23 LOCAL key
	8 EDIT key	24 ON/OFF key
	9 AUTO key	25 - (not used)
	10 Right arrow key	26 SOURCE up arrow key
	11 EXIT key	27 SWEEP key
	12 V (SOURCE) key	28 CONFIG key
	13 LIMITS key	29 Ω key
	14 STORE key	30 REL key
	15 V (MEAS) key	31 DIGITS key
	16 TOGGLE key	32 FRONT/REAR key

Read version of SCPI standard

VERsion?

:SYSTem:VERsion?

Read SCPI version

Description This query command is used to read the version of the SCPI standard being used by the SourceMeter. Example code:
1996.0
The above response message indicates the version of the SCPI standard.

RS-232 interface

LOCal

:SYSTem:LOCal

Take SourceMeter out of remote

Description Normally, during RS-232 communications, front panel keys are operational. However, the user may wish to lock out front panel keys during RS-232 communications.
This action command is used to remove the SourceMeter from the remote state and enables the operation of front panel keys. Note that this command can only be sent over the RS-232 interface.

RWLock

:SYSTem:RWLock

Disable or enable front panel keys

Parameters = 0 or OFF Disable local lockout
 1 or ON Enable local lockout

Query :RWLock Query state of local lockout

Description This command is used to enable or disable local lockout. When enabled, the front panel keys are locked out (not operational) when the instrument is in remote. When disabled, the front panel keys are operational in remote.
Removing the instrument from remote restores front panel keys operation but does not change the status of the :RWLock command. Note that this command can only be sent over the RS-232 interface.

Query timestamp

TIME?

:SYSTem:TIME?

Query timestamp

Query :TIME? Query timestamp

Description This query returns the current timestamp value.

Reset timestamp

RESet

:SYSTem:TIME:RESet

Reset timestamp

Description This action command is used to reset the absolute timestamp to 0 seconds. The timestamp also resets to 0 seconds every time the Source-Meter is turned on.

Auto reset timestamp

RESet:AUTO

:SYSTem:TIME:RESet:AUTO

Reset timestamp when exiting idle

Parameters = 1 or ON Enable auto timestamp reset
0 or OFF Disable auto timestamp reset

Query :AUTO? Query enabled/disabled auto timestamp reset state

Description :RES:AUTO enables or disables auto timestamp reset. When enabled, the timestamp will be automatically reset when exiting the idle layer of the trigger model. This command is intended for use with READ?/INIT when taking more than one reading.

Auto range change mode

RCMode <name>

:SYSTem:RCMode <name>

Control auto range change mode

Parameters <name> = SINGLE Single mode
MULTiple Multiple mode

Query :RCMode? Query auto range change mode

Description This command controls the auto range change mode. In the SINGLE mode, the SourceMeter will auto range only after first taking a reading. In the MULTiple mode, the SourceMeter will auto range up on compliance in the Delay phase of the Source-Delay-Measure cycle, thereby minimizing the chance of a SourceMeter being in compliance in a multiple-SourceMeter system. A SourceMeter can downrange only once a reading has been taken. In the MULTiple mode, you can control the soak time using the :SOUR:SOAK command. (See "[SOURce subsystem](#).”) Note that you can use the LLIMIT and ULIMIT commands to control auto range limits. (See "[SENSe1 subsystem](#).”)

TRACe subsystem

The commands in this subsystem are used to configure and control data storage into the buffer. The commands are summarized in [Table 18-10](#).

:TRACe|:DATA

The bar (|) indicates that :TRACe or :DATA can be used as the root command for this subsystem. From this point on, the documentation in this manual uses :TRACe. If you prefer to use :DATA, simply replace all the :TRACe command words with :DATA.

Read and clear buffer

DATA?

:TRACe:DATA?

Read contents of buffer

Description When this command is sent and the SourceMeter is addressed to talk, all the readings stored in the data store are sent to the computer.
The format used to send readings over the bus is controlled from the :FORMat subsystem.

NOTE See [Appendix C, "Data Flow,"](#) for a detailed explanation on how data flows through the various operation blocks of the SourceMeter. It clarifies the types of readings that are acquired by the various commands to read data.

CLEAr

:TRACe:CLEAr

Clear buffer

Description This action command is used to clear the buffer of readings. If you do not clear the buffer, a subsequent store will overwrite the old readings.

Configure and control buffer

FREE?

:TRACe:FREE?

Read status of memory

Description This command is used to read the status of storage memory. After sending this command and addressing the SourceMeter to talk, two values separated by commas are sent to the computer. The first value indicates how many bytes of memory are available, and the second value indicates how many bytes are reserved to store readings.

POINTS <n>

	:TRACe:POINTs <n>	Specify buffer size
Parameters	<n> =	Specify buffer size
	1 to 2500	
	MINimum	1
	MAXimum	2500
	DEFault	100
Query	:POINTs?	Query buffer size
	:POINTs? MINimum	Query smallest allowable buffer size
	:POINTs? MAXimum	Query largest allowable buffer size
	:POINTs? DEFault	Query *RST default buffer size
Description	This command is used to specify the size of the buffer.	

ACTual?

	:TRACe:POINTs:ACTual?	Query number of stored readings
Description	This query command is used to determine how many stored readings are in the buffer. After sending this command and addressing the unit to talk, the number of readings stored in the buffer will be sent to the computer.	

FEED <name>

	:TRACe:FEED <name>	Specify readings source
Parameters	<name> =	
	SENSe[1]	Put raw readings in buffer
	CALCulate[1]	Put Calc1 readings in buffer
	CALCulate2	Put Calc2 readings in buffer
Query	:FEED?	Query buffer feed
Description	This command is used to select the source of readings to be placed in the buffer. With SENSe[1] selected, raw readings are placed in the buffer when storage is performed. With CALCulate[1] selected, math expression results (Calc1) are placed in the buffer. With CALCulate2 selected, Calc2 readings are placed in the buffer. TRACe:FEED cannot be changed while buffer storage is active. See Section 9 , "Data Store," for more information.	

CONTRol <name>

	:TRACe:FEED:CONTRol <name>	Start or stop buffer
Parameters	<name> =	
	NEXT	Fills buffer and stops
	NEVer	Disables buffer storage
Query	:CONTRol?	Query buffer control

Description This command is used to select the buffer control. When NEXT is selected, the asterisk (*) annunciator turns on to indicate that the buffer is enabled. The storage process starts when SourceMeter is taken out of idle to perform source-measure operations. After the buffer stores the specified number of reading arrays (as set by the :POINTS command), the asterisk annunciator turns off to indicate that storage is done. With NEVer selected, storage into the buffer is disabled.

Select timestamp format

FORMat <name>

:TRACe:TSTamp:FORMat <name>

Select timestamp format

Parameters <name> = ABSolute Reference to first buffer reading
DELTA Time between buffer readings

Query :FORMat? Query timestamp format

Description This command is used to select the timestamp format for buffer readings. With ABSolute selected, each timestamp is referenced to the first reading stored in the buffer. With DELTA selected, timestamps provide the time between each buffer reading.

TRIGger subsystem

The Trigger subsystem is made up of a series of commands and subsystems to configure the Trigger Model. These commands and subsystems are summarized in [Table 18-11](#).

NOTE See [Section 11](#), “*Triggering*,” for more details on triggering and the trigger model.

Clear input triggers

CLEar

:TRIGger:CLEar

Clear pending input triggers

Description When this action command is sent, any pending (latched) input triggers are cleared immediately. When the SourceMeter is being triggered by another instrument, it may inadvertently receive and latch input triggers that do not get executed. These pending triggers could adversely affect subsequent operation.

When using external triggering, it is recommended that TRIGger:CLEar be sent after sending the ABORt command and at the beginning of a program before sending an initiate command. (See “[INITiate](#)” command.)

Initiate source/measure cycle

INITiate

:INITiate[:IMMediate]

Take SourceMeter out of idle state

Description This command is used to initiate source-measure operation by taking the SourceMeter out of idle. The :READ? and :MEASure? commands also perform an initiation.

Note that if auto output-off is disabled (SOURce1:CLEAr:AUTO OFF), the source output must first be turned on before an initiation can be performed. The :MEASure? command automatically turns the output source on before performing the initiation.

WARNING **With auto output-off disabled, the source output will remain on after all programmed source-measure operations are completed. Beware of hazardous voltage ($\geq 30\text{VDC}$, 42.4 peak-to-peak) that may be present on the output terminals.**

With auto output-off enabled, an initiation will start operation immediately. The source output will automatically turn on at the beginning of each SDM (source-delay-measure) cycle and turn off after each measurement is completed.

Abort source/measure cycle

ABORt

Abort operation

Description When this action command is sent, the SourceMeter aborts operation and returns to the idle state.

A faster way to return to idle is to use the DCL or SDC command.

With auto output-off enabled (:SOURce1:CLEAr:AUTO ON), the output will remain on if operation is terminated before the output has a chance to automatically turn off.

Program trigger model

COUNT <n>

:ARM[:SEQuence[1]][LAYer[1]]:COUNT <n>

Set arm count

:TRIGger[:SEQuence[1]]:COUNT <n>

Set trigger count

Parameters	<n> =	1 to 2500	Specify count (see NOTE)
		DEFault	Sets count to 1
		MINimum	Sets count to 1
		MAXimum	See NOTE
		INFinite	(ARM:COUNT only)

NOTE The product of arm count and trigger count cannot exceed 2500.

Query	:COUNT?	Queries programmed count
	:COUNT? DEFault	Queries *RST default count
	:COUNT? MINimum	Queries lowest allowable count
	:COUNT? MAXimum	Queries largest allowable count
Description	<p>This command is used to specify how many times an operation is performed in the specified layer of the trigger model.</p> <p>For example, assume the arm count is set to 2 and the trigger counter is set to 10, the SourceMeter is configured to perform 10 source-measure operations twice for a total of 20 source-measure operations.</p> <p>The product of the arm count and trigger count cannot exceed 2500. If, for example, the arm count is 2, then the maximum trigger count is 1250.</p>	

NOTE *INFinite* can be used only with *ARM:COUNT*, and *FETCh?*, *READ?*, *MEAS?*, *CALC1:DATA?*, or *CALC2:DATA?* cannot be used with infinite arm count. Only *INIT* will start measurements, and only output enable line, over-temperature, *SDC*, *DCL*, or *ABORt* should be used to stop the sweep.

ARM:COUNT INFinite can be used for repetitive source waveforms or for long tests where only the last reading is important. For example, the limits could be used to drive the output enable to abort a test when some condition is met. *DATA?* would then give the answer to the test.

DElAy <n>

	:TRIGger[:SEquence[1]]:DElAy <n>	Set trigger layer delay	
Parameters	<n> =	0 to 999.9999	
		DEFault	0 second delay
		MINimum	0 second delay
		MAXimum	999.9999 second delay
Query	:DElAy?	Query the programmed delay	
	:DElAy? DEFault	Query the *RST default delay	
	:DElAy? MINimum	Query the lowest allowable delay	
	:DElAy? MAXimum	Query the largest allowable delay	
Description	<p>The delay is used to delay operation in the trigger layer. After the programmed trigger event occurs, the instrument waits until the delay period expires before performing the Device Action.</p>		

NOTE For the Model 2430 Pulse Mode, trigger delay is not used. The Pulse Mode uses pulse width and pulse delay for pulse timing. See [Section 5](#) for details on Pulse Mode.

SOURce <name>

:ARM[:SEquence[1]][LAYER[1]]:SOURce <name>

Specify arm event control source

:TRIGger[:SEquence[1]]:SOURce <name>

Specify trigger event control source

Parameters	<name> =	IMMEDIATE	Pass operation through immediately
		TLINK	Select Trigger Link trigger as event
		TIMER	Select timer as event
		MANual	Select manual event
		BUS	Select bus trigger as event
		NSTest	Select low SOT pulse as event
		PSTest	Select high SOT pulse as event
		BSTest	Select high or low SOT pulse as event

NOTE Only IMMEDIATE and TLINK are available as trigger layer control sources.

Query :SOURce? Query programmed control source

Description These commands are used to select the event control source. With IMMEDIATE, selected operation immediately continues.
A specific event can be used to control operation. With TLINK selected, operation continues when a trigger pulse is received via the Trigger Link.

NOTE The following control sources are not available for the trigger layer.

With **TIMER** selected, the event occurs at the beginning of the timer interval, and every time it times out. For example, if the timer is programmed for a 30 second interval, the first pass through the control source occurs immediately. Subsequent arm events will then occur every 30 seconds. The interval for the timer is set using the :TIMER command.

With **MANual** selected, the event occurs when the TRIG key is pressed.

With **BUS** selected, the event occurs when a GET or *TRG command is sent over the bus.

With **NSTEST** selected, the event occurs when the start-of-test (SOT) low pulse is received from a component handler via the Digital I/O port. This is used for limit testing.

With **PSTEST** selected, the event occurs when start-of-test (SOT) high pulse is received from a component handler via the Digital I/O port. This is used for limit testing.

TIMer <n>

:ARM[:SEquence[1]][:LAYer[1]]:TIMer <n> Set interval for arm layer timer

Parameters <n> = 0.001 to 9999.999 Specify timer interval in seconds
10000.00 to 99999.99 Specify timer interval in seconds

Query :TIMer? Query programmed timer interval

Description These commands are used to set the interval for the timer. Note that the timer is in effect only if the timer is the selected control source.

DIRection <name>

:ARM[:SEquence[1]][:LAYer[1]]:TCONfigure:DIRection <name> Control arm bypass

:TRIGger[:SEquence[1]]:TCONfigure:DIRection <name> Control trigger bypass

Parameters <name> = SOURce Enable control source bypass
ACCEptor Disable control source bypass

Query :DIRection? Query state of bypass

Description This command is used to enable (SOURce) or disable (ACCEptor) control source bypass. When enabled, operation will loop around the control source on the first pass in the layer. After that, repeat passes in the layer are held up and will wait for the programmed control source event.

INPut <event list>

:TRIGger[:SEquence[1]]:TCONfigure[:ASYNchronous]:INPut <event list> Enable event detectors

Parameters <event list> = SOURce Enable Source Event Detector
DELay Enable Delay Event Detector
SENSe Enable Measure Event Detector
NONEDisable all event detectors in Trigger Layer

NOTE Each event in the list must be separated by a comma (i.e. *trigger:input source, delay, sense*).

Query :INPut? Query enabled event detectors in Trigger Layer

Description When TLINK is the selected Trigger Layer control source, and an event detector in the Trigger Layer is enabled, operation will hold up at that detector until an input trigger is received via the Trigger Link. When the event detector is disabled, operation will not hold up. It continues and performs the appropriate action.

A Trigger Layer event detector is enabled by including the parameter name in the event list for the INPut command. For example, to enable the Source Event Detector and Measure Event Detector, send the following command:

```
:TRIGger:INPut SOURce, SENSE
```

The Delay Event Detector will be disabled since the DELay parameter is not included in the above event list.

NOTE To disable all the Trigger Layer event detectors, the NONE parameter must be sent alone (i.e. trigger:input none). If it is listed with any of the other parameters, NONE will be ignored.

ILINe <NRf>

:ARM[:SEquence[1]][LAYer[1]]:TCONfigure):ILINe <NRf> Select input line; arm layer
:TRIGger[:SEquence[1]]:TCONfigure):ILINe <NRf> Select input line; trigger layer

Parameters	<NRf> =	1	Line #1
		2	Line #2
		3	Line #3
		4	Line #4

Query :ILINe? Query input trigger line

Description This command is used to select input lines for the Trigger Link. For normal operation, Trigger Link input and output (see "OLINe <NRf>") should not share the same line.

OLINe <NRf>

:ARM[:SEquence[1]][LAYer[1]]:TCONfigure):OLINe <NRf> Select output line; arm layer
:TRIGger[:SEquence[1]]:TCONfigure):OLINe <NRf> Select output line; trigger layer

Parameters	<NRf> =	1	Line #1
		2	Line #2
		3	Line #3
		4	Line #4

Query :OLINe? Query output trigger line

Description This command is used to select output lines for the Trigger Link. For normal operation, Trigger Link input and output (see "ILINe <NRf>") should not share the same line.

OUTPut <event list>

:ARM[:SEquence[1]][LAYer[1]]:TCONfigure):OUTPut <event list> Arm layer events
:TRIGger[:SEquence[1]]:TCONfigure):OUTPut <event list> Trigger layer events

Parameters	Arm Layer Triggers	
	<event list >: TENTer	Trigger on entering trigger layer
	TEXit	Trigger on exiting trigger layer
	NONE	Disable arm layer output trigger
	Trigger Layer Triggers	
	<event list>: SOURce	Output trigger after source level is set
	DELay	Output trigger after delay period
	SENSe	Output Trigger after measurement
	NONE	Disable trigger layer triggers

NOTE Each event in the list must be separated by a comma. (i.e., `:arm:output source, delay, sense`).

Query `:OUTPut?` Query output trigger event(s)

Description This command is used to specify when trigger pulses occur on the specified output trigger line of the Trigger Link (see [“OLINe <NRf>,” page 18-121](#)).

Arm Layer Triggers — With `TEXit` selected, an output trigger will occur when exiting the trigger layer. With `TENTer` selected, an output trigger will occur when entering the trigger layer. With `NONE` selected, the arm layer output trigger is disabled.

Trigger Layer Triggers — You can specify from one to all three events. Each event in the list must be separated by a comma (,). The `SOURce`, `DELay`, and `MEASure` events refer to the Source-Delay-Measure (SDM) cycle. This is the Device Action in the Trigger Model. (See [Figure 11-8](#) and [Figure 11-9](#).) With `SOURce` specified, an output trigger occurs after the source is set. With `DELay` specified, an output trigger occurs after the delay period. With `MEASure` specified, an output trigger occurs after the measurement.

NOTE When disabling triggers, the `NONE` parameter must be sent alone (i.e., `trig:outp none`). If it is listed with any of the other event parameters, `NONE` will be ignored.

A Specifications

Accuracy calculations

The information below discusses how to calculate accuracy for both sense and source functions.

Measure accuracy

Measurement accuracy is calculated as follows:

Accuracy = \pm (% of reading + offset)

As an example of how to calculate the actual reading limits, assume that you are measuring 10V on the 20V range. You can compute the reading limit range from one-year measure voltage accuracy specifications as follows:

$$\begin{aligned}\text{Accuracy} &= \pm(\% \text{ of reading} + \text{offset}) \\ &= \pm[(0.015\% \times 10\text{V}) + 1.5\text{mV}] \\ &= \pm(1.5\text{mV} + 1.5\text{mV}) \\ &= \pm 3\text{mV}\end{aligned}$$

Thus, the actual reading range is 10V \pm 3mV or from 9.997 to 10.003V.

DC current measurement calculations are performed in exactly the same manner using the pertinent specifications, ranges, and input signal values.

Source accuracy

Source accuracy is calculated similarly, except source specifications are used. As an example of how to calculate the actual source output limits, assume that you are sourcing 0.7mA on the 1mA source range. You can compute the reading limit range from source current one-year accuracy specifications as follows:

$$\begin{aligned}\text{Accuracy} &= \pm(0.034\% \text{ of output} + 200\text{nA offset}) \\ &= \pm[(0.034\% \times 0.7\text{mA}) + 200\text{nA}] \\ &= \pm(238\text{nA} + 200\text{nA}) \\ &= \pm 438\text{nA}\end{aligned}$$

In this case, the actual current output range is 0.7mA \pm 438nA or from 0.69956mA to 0.70044mA.

Source-Delay-Measure (SDM) cycle timing

The following timing information assumes that the SourceMeter is being triggered externally via the Trigger Link.

For Cases I through IV, it is assumed that the Output Auto-Off feature is enabled (:SOURce1:CLEAr:AUTO ON), and the source setting changes for each triggered SDM cycle. The discussion is applicable for linear, log, and custom sweeps. It is also applicable to applications that use the “triggered source” feature (:SOURce1:VOLTage:TRIGger or SOURce1:CURRent:TRIGger). The discussion is not applicable for memory sweeps (:SOURce1:MEMory).

For Cases V and VI, it is assumed that the Output Auto-Off feature is disabled (:SOURce1:CLEAr:AUTO OFF), and the source setting remains the same for each triggered SDM cycle. In this configuration, the static source remains on during all SDM cycles.

Definitions

Trigger latency

Trigger latency is the time from when an external trigger event occurs to when the Source-Meter takes the appropriate action. It is from when an external trigger is detected in the Trigger Layer of the trigger model to when the trigger delay begins.

Trigger delay

Trigger delay is the time from when the external event is detected to when the source configuration begins. This is a user-programmable delay that can be set from 0000.0000 seconds to 999.99990 seconds.

Source configuration

This is the time it takes to configure the source DAC. For the following discussion, it is assumed that the range and polarity do not change when the source value is changed.

Source delay

This is the time between the source configuration and the start of the first A/D conversion. This programmable delay is typically used to allow the source to settle before starting the measurement. With Auto-Delay enabled, 100µsec is added to the user-programmed source delay. The user-programmed delay can be set from 0000.0000 seconds to 9999.99900 seconds.

A/D conversion

This is the time it takes to measure the specified A/D converter phase. In general, there are three A/D phases required to generate a voltage or current reading. These phases are often referred to as the signal, reference, and reference zero phases. The signal phase measures the input signal. The reference and reference zero phases are associated with a precision voltage reference inside the SourceMeter. By measuring all three phases, zero drift for the reading is reduced. A/D conversion time is programmable with 0.01 power line cycle resolution.

When Auto-Zero is enabled, all three phases are measured each time the SourceMeter is triggered. With Auto-Zero disabled, only the signal is measured. Hence, speed is increased at the expense of long term drift.

Firmware overhead

This is the time associated with A/D communication, reading calibration, and other operations necessary to perform the SDM cycle. This time is not illustrated in the following timing diagrams.

Timing diagrams

Case I: Auto-Zero enabled and measuring a single function

Figure A-1
Case I Timing Diagram

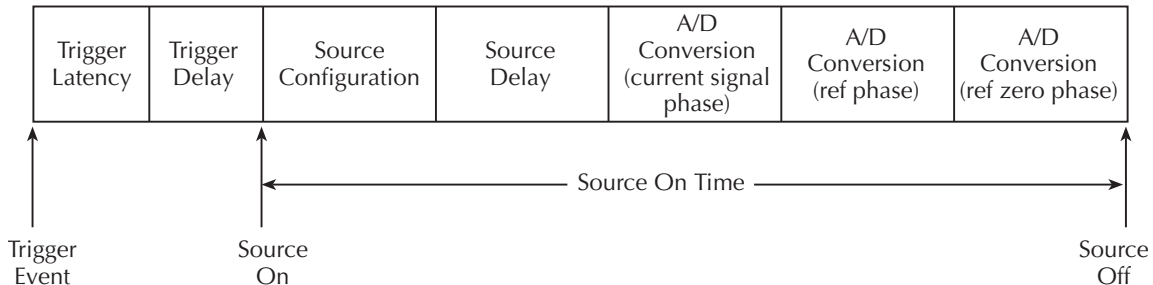

Trigger Latency:	225µsec max
Source Configuration:	50µsec max
A/D Conversion:	$[\text{NPLC Setting} \times (1/\text{power line frequency})] + 185$
Firmware Overhead:	1.8msec for Source V
	2.15msec for Source I

Source On Time \cong Source Configuration + Source Delay + (3 \times A/D Conversion) + Firmware Overhead

Example: Source Delay = 0 μ sec
 NPLC Setting = 0.01 PLC
 Power Line Frequency = 60Hz

Source On Time \cong 50 μ sec + 0 + [(3 \times 0.01 \times 1/60) + 185 μ sec] + 1.6msec
 \cong 2.9msec for Source V
 \cong 3.25msec for Source I

Case II: Auto Zero enabled and measuring two functions

Figure A-2
Case II Timing Diagram

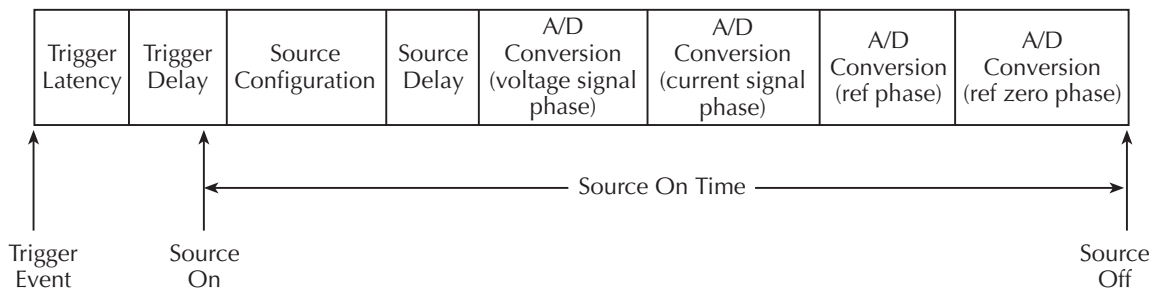

Trigger Latency: 225 μ sec max
 Source Configuration: 50 μ sec max
 A/D Conversion: [NPLC Setting \times (1 / power line frequency)] + 185 μ sec
 Firmware Overhead: 2.3msec for Source V
 2.65msec for Source I

Source On Time \cong Source Configuration + Source Delay + (4 \times A/D Conversion) + Firmware Overhead

Example: Source Delay = 0 μ sec
 NPLC Setting = 0.06 PLC
 Power Line Frequency = 60Hz

Source On Time \cong 50 μ sec + 0 + [(4 \times 0.06 \times 1/60) + 185 μ sec] + 2.6msec
 \cong 7.1msec for Source V
 \cong 7.45msec for Source I

Case III: Auto-Zero disabled and measuring one function

Figure A-3
Case III Timing Diagram

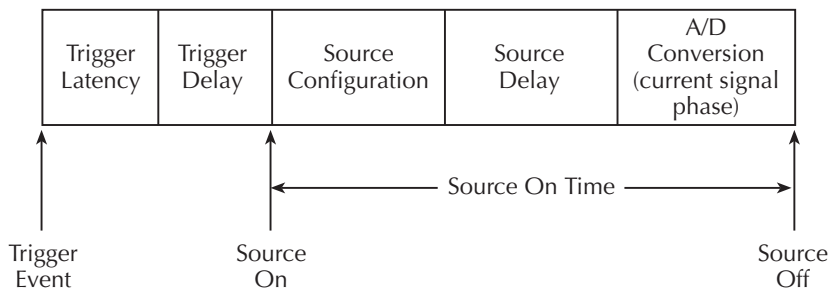

Trigger Latency: 225μsec max
 Source Configuration: 50μsec max
 A/D Conversion: [NPLC Setting × (1 / power line frequency)] + 185μsec
 Firmware Overhead: 300μsec for Source V
 640μsec for Source I

Source On Time \cong Source Configuration + Source Delay + A/D Conversion + Firmware Overhead

Example: Source Delay = 0
 NPLC Setting = 0.08 PLC
 Power Line Frequency = 60Hz

Source On Time \cong 50μsec + 0 + [(0.08 × 1/60) + 185μsec] + 40μsec
 \cong 1.85msec for Source V
 \cong 2.2msec for Source I

Case IV: Auto-Zero disabled and all measurements disabled

Figure A-4
Case IV Timing Diagram

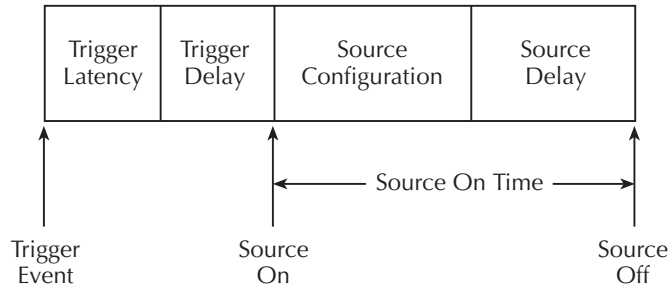

Trigger Latency: 225μsec max
 Source Configuration: 50μsec max
 Firmware Overhead: 310μsec for Source V
 590μsec for Source I

Source On Time \cong Source Configuration + Source Delay + Firmware Overhead

Example: Source Delay = 0

Source On Time \cong 50μsec + 0 + 125μsec
 \cong 360μsec for Source V
 \cong 640μsec for Source I

Cases V and VI: Measure one function, Output Auto-Off disabled, and no source setting changes

Figure A-5
Case V Timing Diagram

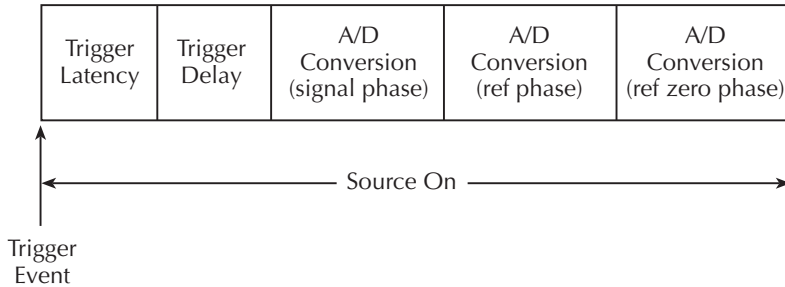

Auto-Zero: Enabled
Trigger Latency: 500µsec max

Figure A-6
Case VI Timing Diagram

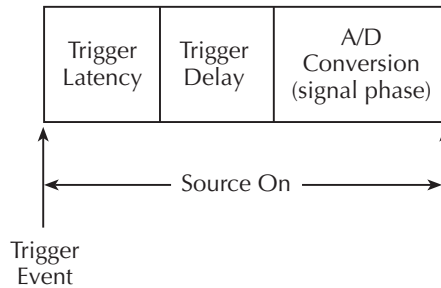

Auto Zero: Disabled
Trigger Latency: 100µsec max

The source turns on as soon as the output is turned on and remains on until the source is turned off. As shown in the two timing diagrams, the static source remains on for every measurement cycle. The Source-Delay portion of the SDM cycle is omitted. With Trigger Delay set to zero, Trigger Latency is the time from when the trigger event occurs to when the SourceMeter begins an A/D conversion.

B

Status and Error Messages

Introduction

This Appendix contains a summary of status and error messages, which status register bits are set when messages occur, and methods to avoid or eliminate most common SCPI errors.

Status and error messages

[Table B-1](#) summarizes status and error messages, which are stored in the Error Queue. Each message is preceded by a code number. Negative (-) numbers are used for SCPI defined messages, and positive (+) numbers are used for Keithley defined messages. Note that error and status conditions will also set specific bits in various status registers, as summarized in [Table B-1](#).

[Section 15](#) has detailed information on registers and queues. Briefly, you can use the following queries to obtain error and status information:

- `:SYST:ERR?` — reads Error Queue.
- `*ESR?` — reads Standard Event Status Register.
- `:STAT:OPER?` — reads Operation Event Register.
- `:STAT:MEAS?` — reads Measurement Event Register.
- `:STAT:QUES?` — reads Questionable Event Register.

NOTE *SCPI confirmed messages are described in volume 2: Command Reference of the Standard Commands for Programmable Instruments. Refer to the `:SYSTem:ERRor?` command.*

Table B-1
Status and error messages

Number	Error message	Event ¹	Status register ²	Bit
-440	Query UNTERMINATED after indefinite response	EE	Standard Event	2
-430	Query DEADLOCKED	EE	Standard Event	2
-420	Query UNTERMINATED	EE	Standard Event	2
-410	Query INTERRUPTED	EE	Standard Event	2
-363	Input buffer overrun	EE	Standard Event	3
-362	Framing error in program message	EE	Standard Event	3
-361	Parity error in program message	EE	Standard Event	3
-360	Communications error	EE	Standard Event	3
-350	Queue overflow	SYS	Standard Event	3
-330	Self-test failed	EE	Standard Event	3
-314	Save/recall memory lost	EE	Standard Event	3
-315	Configuration memory lost	EE	Standard Event	3
-285	Program syntax error	EE	Standard Event	4
-284	Program currently running	EE	Standard Event	4
-282	Illegal program name	EE	Standard Event	4
-281	Cannot create program	EE	Standard Event	4
-260	Expression error	EE	Standard Event	4
-241	Hardware missing	EE	Standard Event	4
-230	Data corrupt or stale	EE	Standard Event	4
-225	Out of memory	EE	Standard Event	4
-224	Illegal parameter value	EE	Standard Event	4
-223	Too much data	EE	Standard Event	4
-222	Parameter data out of range	EE	Standard Event	4
-221	Settings conflict	EE	Standard Event	4
-220	Parameter error	EE	Standard Event	4
-215	Arm deadlock	EE	Standard Event	4
-214	Trigger deadlock	EE	Standard Event	4
-213	Init ignored	EE	Standard Event	4
-212	Arm ignored	EE	Standard Event	4
-211	Trigger ignored	EE	Standard Event	4
-210	Trigger error	EE	Standard Event	4
-202	Settings lost due to rtl	EE	Standard Event	4
-201	Invalid while in local	EE	Standard Event	4
-200	Execution error	EE	Standard Event	4

Table B-1 (continued)
Status and error messages

Number	Error message	Event ¹	Status register ²	Bit
-178	Expression data not allowed	EE	Standard Event	5
-171	Invalid expression	EE	Standard Event	5
-170	Expression error	EE	Standard Event	5
-168	Block data not allowed	EE	Standard Event	5
-161	Invalid block data	EE	Standard Event	5
-160	Block data error	EE	Standard Event	5
-158	String data not allowed	EE	Standard Event	5
-154	String too long	EE	Standard Event	5
-151	Invalid string data	EE	Standard Event	5
-150	String data error	EE	Standard Event	5
-148	Character data not allowed	EE	Standard Event	5
-144	Character data too long	EE	Standard Event	5
-141	Invalid character data	EE	Standard Event	5
-140	Character data error	EE	Standard Event	5
-128	Numeric data not allowed	EE	Standard Event	5
-124	Too many digits	EE	Standard Event	5
-123	Exponent too large	EE	Standard Event	5
-121	Invalid character in number	EE	Standard Event	5
-120	Numeric data error	EE	Standard Event	5
-114	Header suffix out of range	EE	Standard Event	5
-113	Undefined header	EE	Standard Event	5
-112	Program mnemonic too long	EE	Standard Event	5
-111	Header separator error	EE	Standard Event	5
-110	Command header error	EE	Standard Event	5
-109	Missing parameter	EE	Standard Event	5
-108	Parameter not allowed	EE	Standard Event	5
-105	GET not allowed	EE	Standard Event	5
-104	Data type error	EE	Standard Event	5
-103	Invalid separator	EE	Standard Event	5
-102	Syntax error	EE	Standard Event	5
-101	Invalid character	EE	Standard Event	5
-100	Command error	EE	Standard Event	5
+000	No error	SE		

Table B-1 (continued)
Status and error messages

	Error message	Event¹	Status register²	Bit
	Measurement events:			
+100	Limit 1 failed	SE	Measurement Event	0
+101	Low limit 2 failed	SE	Measurement Event	1
+102	High limit 2 failed	SE	Measurement Event	2
+103	Low limit 3 failed	SE	Measurement Event	3
+104	High limit 3 failed	SE	Measurement Event	4
+105	Active limit tests passed	SE	Measurement Event	5
+106	Reading available	SE	Measurement Event	6
+107	Reading overflow	SE	Measurement Event	7
+108	Buffer available	SE	Measurement Event	8
+109	Buffer full	SE	Measurement Event	9
+110	Limit 4 failed	SE*	Measurement Event	10
+111	OUTPUT enable asserted	SE	Measurement Event	11
+112	Temperature limit exceeded	SE	Measurement Event	12
+113	Voltage limit exceeded	SE	Measurement Event	13
+114	Source in compliance	SE	Measurement Event	14
	Standard events:			
+200	Operation complete	SE	Standard Event	0
	Operation events:			
+300	Device calibrating	SE	Operation Event	0
+303	Device sweeping	SE	Operation Event	3
+305	Waiting in trigger layer	SE	Operation Event	5
+306	Waiting in arm layer	SE	Operation Event	6
+310	Entering idle layer	SE	Operation Event	10
	Questionable events:			
+408	Questionable Calibration	SE	Questionable Event	8
+414	Command Warning	SE	Questionable Event	14

* Contact check option only.

Table B-1 (continued)
Status and error messages

Number	Error message	Event ¹	Status register ²	Bit
	Calibration errors:			
+500	Date of calibration not set	EE	Standard Event	3
+501	Next date of calibration not set	EE	Standard Event	3
+502	Calibration data invalid	EE	Standard Event	3
+503	DAC calibration overflow	EE	Standard Event	3
+504	DAC calibration underflow	EE	Standard Event	3
+505	Source offset data invalid	EE	Standard Event	3
+506	Source gain data invalid	EE	Standard Event	3
+507	Measurement offset data invalid	EE	Standard Event	3
+508	Measurement gain data invalid	EE	Standard Event	3
+509	Not permitted with cal locked	EE	Standard Event	3
+510	Not permitted with cal un-locked	EE	Standard Event	3
	Lost data errors:			
+601	Reading buffer data lost	EE	Standard Event	3
+602	GPIB address lost	EE	Standard Event	3
+603	Power-on state lost	EE	Standard Event	3
+604	DC calibration data lost	EE	Standard Event	3
+605	Calibration dates lost	EE	Standard Event	3
+606	GPIB communication language lost	EE	Standard Event	3
	Communication errors:			
+700	Invalid system communication	EE	Standard Event	3
+701	ASCII only with RS-232	EE	Standard Event	3
	Additional command execution errors:			
	Illegal with storage active			
+800	Insufficient vector data	EE	Standard Event	4
+801	OUTPUT blocked by output enable	EE	Standard Event	4
+802	Not permitted with OUTPUT off	EE	Standard Event	4
+803	Expression list full	EE	Standard Event	4
+804	Undefined expression exists	EE	Standard Event	4
+805	Expression not found	EE	Standard Event	4
+806	Definition not allowed	EE	Standard Event	4
+807	Expression cannot be deleted	EE	Standard Event	4
+808	Source memory location revised	EE	Standard Event	4
+809	OUTPUT blocked by Over Temp	EE	Standard Event	4
+810		EE	Standard Event	4

Table B-1 (continued)
Status and error messages

Number	Error message	Event ¹	Status register ²	Bit
+811	Not an operator or number	EE	Standard Event	4
+812	Mismatched parenthesis	EE	Standard Event	4
+813	Not a number of data handle	EE	Standard Event	4
+814	Mismatched brackets	EE	Standard Event	4
+815	Too many parenthesis	EE	Standard Event	4
+816	Entire expression not parsed	EE	Standard Event	4
+817	Unknown token	EE	Standard Event	4
+818	Error parsing mantissa	EE	Standard Event	4
+819	Error parsing exponent	EE	Standard Event	4
+820	Error parsing value	EE	Standard Event	4
+821	Invalid data handle index	EE	Standard Event	4
+822	Too small for sense range	EE	Standard Event	4
+823	Invalid with source read-back on	EE	Standard Event	4
+824	Cannot exceed compliance range	EE	Standard Event	4
+825	Invalid with auto-ohms on	EE	Standard Event	4
+826	Attempt to exceed power limit	EE	Standard Event	4
+827	Invalid with ohms guard on	EE	Standard Event	4
+828	Invalid on 1 amp range	EE	Standard Event	4
+829	Invalid on 1kV range	EE	Standard Event	4
+830	Invalid with INF ARM:COUNT	EE	Standard Event	4
+831	Invalid in Pulse Mode	EE	Standard Event	4
+900	Internal System Error	EE	Standard Event	3

- EE = Error Event
SE = Status Event
SYS = System Error Event
- Use following queries to read status registers:
Standard Event: *ESR?
Operation Event: STAT:OPER?
Measurement Event: STAT:MEAS?
Questionable Event: STAT:QUES?

Eliminating common SCPI errors

There are three SCPI errors that occur more often than any others:

- -113, "Undefined header"
- -410, "Query INTERRUPTED"
- -420, "Query UNTERMINATED"

The following paragraphs discuss the most likely causes for these errors and methods for avoiding them.

-113, "Undefined header"

This error indicates that the command you sent to the instrument did not contain a recognizable command name. The most likely causes for this error are:

- *Missing space between the command and its parameter.* There must be one or more spaces (blanks) between the command and its parameter. For example:

:SENS:VOLT:DC:RANG100 Incorrect (no space between command and parameter)

:SENS:VOLT:DC:RANG 100Correct

- *Improper short or long form.* Check the command list in Section 18 of this manual.
- *Blanks (spaces) within the command name.* For example:

:SYST :ERR? Incorrect (space between :SYST and :ERR?)

:SYST:ERR? Correct

-410, "Query INTERRUPTED"

This error occurs when you have sent a valid query to the instrument, and then send it another command or query, or a Group Execute Trigger (GET) before it has had a chance to send the entire response message (including the line-feed/EOI terminator). The most likely causes are:

- *Sending a query to the instrument and then sending another command or query before reading the response to the first query.* For example, the following sequence of commands will cause an error -410:

:SYST:ERR?

*OPC?

This sequence generates an error because you must read the response to :SYST:ERR? before sending the *OPC? query.

- *Incorrectly configured IEEE-488 driver.* The driver must be configured so that when talking on the bus it sends line-feed with EOI as the terminator, and when listening on the bus it expects line-feed with EOI as the terminator. See the reference manual for your particular IEEE-488 interface.

-420, "Query UNTERMINATED"

This error occurs when you address the instrument to talk, and there is no response message to send. The most likely causes are:

- *Not sending a query.* You must send a valid query to the instrument before addressing it to talk.
- *Sending an invalid query.* If you have sent a query and still get this error, make sure that the instrument is processing the query without error. For example, sending an ill-formed query that generates an error -113, "Undefined header" and then addressing the instrument to talk will generate an error -420, "Query UNTERMINATED" as well.
- *Valid query following an invalid command.* This situation can occur when you send multiple commands or queries (program message units) within one command string (program message). When the SourceMeter detects an error in a program message unit, it discards all further program message units until the end of the string; for example:

```
:SENS:DATE?; :SENS:FUNC?
```

In the above program message, the program message unit :SENS:DATE? will generate error -113, "Undefined header," and the SourceMeter will discard the second program message unit :SENS:FUNC? even though it is a valid query.

C Data Flow

Introduction

Data flow for remote operation is summarized by the block diagram shown in [Figure C-1](#). Refer to this block diagram for the following discussion.

Figure C-1
Data flow block diagram

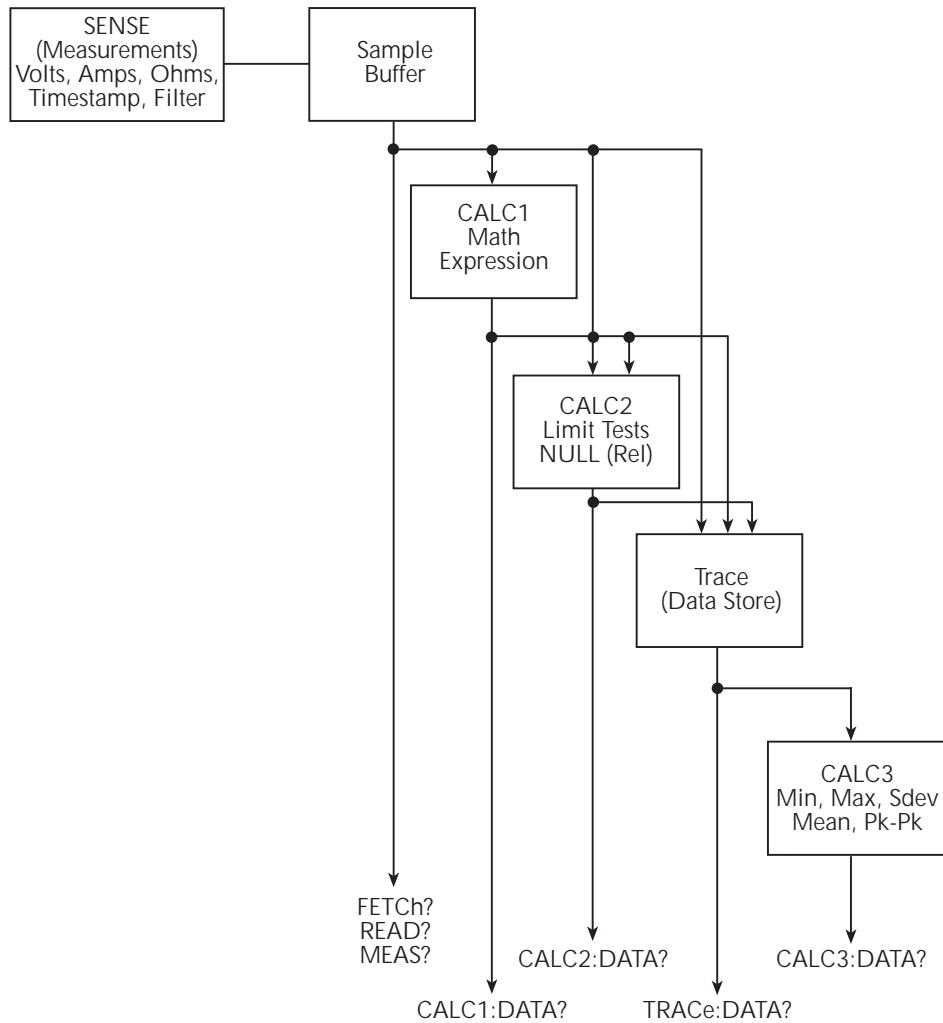

The SENSE block represents the basic measured readings of voltage, current, and resistance. If Filter is enabled, the readings will be filtered. The SENSE block also measures time for the timestamp.

When the INITiate command is sent, the programmed number of source-measure operations are performed and the respective data is temporarily stored in the Sample Buffer. For example, if 20 source-measure operations were performed, then 20 sets of data will be stored in the Sample Buffer. Data from this buffer is then routed to other enabled data flow blocks.

Assuming that all functions are enabled, the data that is output by the read commands (FETCh?, CALC1:DATA?, CALC2:DATA?, TRACe:DATA?, and CALC3:DATA?) depend on which data elements are selected. With all elements selected, available data will include voltage, current and resistance readings as well as the time stamp and status information. Note that if a measurement function is not enabled, then either the NAN (not a number) value or the source reading will instead be used. (See [Section 18, "FORMat subsystem,"](#) for details).

After all source-measure operations are completed, the SourceMeter returns to the idle state. The data stored in the Sample Buffer will remain there until data from another source-measure cycle overwrites the buffer. Data in the Sample Buffer is lost if the SourceMeter goes to the local state (REM annunciator off).

NOTE *With no data in the Sample Buffer, the FETCh?, CALCulate1:DATA?, and CALCulate2:DATA? commands to read data will display the message "Data corrupt or stale."*

FETCh?

This command is used to read data stored in the Sample Buffer. If, for example, there are 20 data arrays stored in the Sample Buffer, then all 20 data arrays will be sent to the computer when FETCh? is executed. Note that FETCh? does not affect data in the Sample Buffer. Thus, subsequent executions of FETCh? acquire the same data.

The READ? command performs an INITiate and then a FETCh? The INITiate triggers a new source-measure cycle which puts new data in the Sample Buffer. FETCh? reads that new data. The MEASure? command places the SourceMeter in a "one-shot" source-measure mode and then performs a READ?. See [Section 17, "SCPI Signal Oriented Measurement Commands,"](#) for more information on READ? and MEASure?.

CALCulate[1]:DATA?

If CALCulate1 is enabled, Sample Buffer data is fed to the CALC1 block where the results for the selected math expression are calculated. The CALC1:DATA? command will read the results of the math expression. If, for example, 20 data arrays in the Sample Buffer yield 10 math expression results, then CALC1:DATA? will acquire 10 readings (results).

CALCulate2:DATA?

If CALCulate2 is enabled, Sample Buffer data and CALC1 math expression results become available to the CALC2 block for limit testing. Depending on the selected feed, limit testing can be performed on the voltage, current, resistance, or timestamp readings of Sample Buffer data, or it can be performed on the CALC1 math expression results. If NULL (rel) is enabled, the readings used for limit testing will be the results of the null operation.

The CALCulate2:DATA? command acquires the readings used for limit testing.

TRACe:DATA?

If the data store is enabled, Sample Buffer data, CALC1 results and CALC2 readings become available to the TRACE block for storage. The selected feed determines which group of readings are stored.

The TRACe:DATA? command reads the entire contents of the data store.

CALCulate3:DATA?

Statistical information (minimum, maximum, mean, standard deviation, and peak-to-peak) is available for measure readings stored in the buffer. If the readings in the data store came directly from the Sample Buffer, then the selected statistic calculation will be performed on all enabled measurement functions. The calculation results are returned in the following fixed order:

VOLTage result, CURRent result, RESistance result

When the TRACE buffer is feeding off CALC1 or CALC2, the selected statistic calculation is performed on the selected feed. Thus, a single statistic result is acquired for each reading stored in the data store.

The CALCulate3:DATA? command acquires the results of the selected calculation.

D

IEEE-488 Bus Overview

Introduction

Basically, the IEEE-488 bus is a communication system between two or more electronic devices. A device can be either an instrument or a computer. When a computer is used on the bus, it serves to supervise the communication exchange between all the devices and is known as the controller. Supervision by the controller consists of determining which device will talk and which device will listen. As a talker, a device will output information and as a listener, a device will receive information. To simplify the task of keeping track of the devices, a unique address number is assigned to each one.

On the bus, only one device can talk at a time and is addressed to talk by the controller. The device that is talking is known as the active talker. The devices that need to listen to the talker are addressed to listen by the controller. Each listener is then referred to as an active listener. Devices that do not need to listen are instructed to unlisten. The reason for the unlisten instruction is to optimize the speed of bus information transfer since the task of listening takes up bus time.

Through the use of control lines, a handshake sequence takes place in the transfer process of information from a talker to a listener. This handshake sequence helps ensure the credibility of the information transfer. The basic handshake sequence between an active controller (talker) and a listener is as follows:

1. The listener indicates that it is ready to listen.
2. The talker places the byte of data on the bus and indicates that the data is available to the listener.
3. The listener, aware that the data is available, accepts the data and then indicates that the data has been accepted.
4. The talker, aware that the data has been accepted, stops sending data and indicates that data is not being sent.
5. The listener, aware that there is no data on the bus, indicates that it is ready for the next byte of data.

Bus description

The IEEE-488 bus, which is also frequently referred to as the GPIB (General Purpose Interface Bus), was designed as a parallel transfer medium to optimize data transfer without using an excessive number of bus lines. In keeping with this goal, the bus has only eight data lines that are used for both data and with most commands. Five bus management lines and three handshake lines round out the complement of bus signal lines.

A typical set up for controlled operation is shown in [Figure D-1](#). Generally, a system will contain one controller and a number of other instruments to which the commands are given. Device operation is categorized into three operators: controller, talker, and listener. The controller does what its name implies; it controls the instruments on the bus. The talker sends data while a listener receives data. Depending on the type of instrument, any particular device can be a talker only, a listener only, or both a talker and listener.

There are two categories of controllers: system controller, and basic controller. Both are able to control other instruments, but only the system controller has the absolute authority in the system. In a system with more than one controller, only one controller may be active at any given time. Certain protocol is used to pass control from one controller to another.

The IEEE-488 bus is limited to 15 devices, including the controller. Thus, any number of talkers and listeners up to that limit may be present on the bus at one time. Although several devices may be commanded to listen simultaneously, the bus can have only one active talker, or communications would be scrambled.

A device is placed in the talk or listen state by sending an appropriate talk or listen command. These talk and listen commands are derived from an instrument's primary address. The primary address may have any value between 0 and 31, and is generally set by rear panel DIP switches or programmed from the front panel of the instrument. The actual listen address value sent out over the bus is obtained by ORing the primary address with #H20. For example, if the primary address is #H16, the actual listen address is #H36 ($\#H36 = \#H16 + \#H20$). In a similar manner, the talk address is obtained by ORing the primary address with #H40. With the present example, the talk address derived from a primary address of 16 decimal would be #H56 ($\#H56 = \#H16 + \#H40$).

The IEEE-488 standards also include another addressing mode called secondary addressing. Secondary addresses lie in the range of #H60-#H7F. Note, however, that many devices, including the SourceMeter, do not use secondary addressing.

Once a device is addressed to talk or listen, the appropriate bus transactions take place. For example: if the instrument is addressed to talk, it places its data string on the bus one byte at a time. The controller reads the information and the appropriate software can be used to direct the information to the desired location.

Figure D-1
IEEE-488 bus configuration

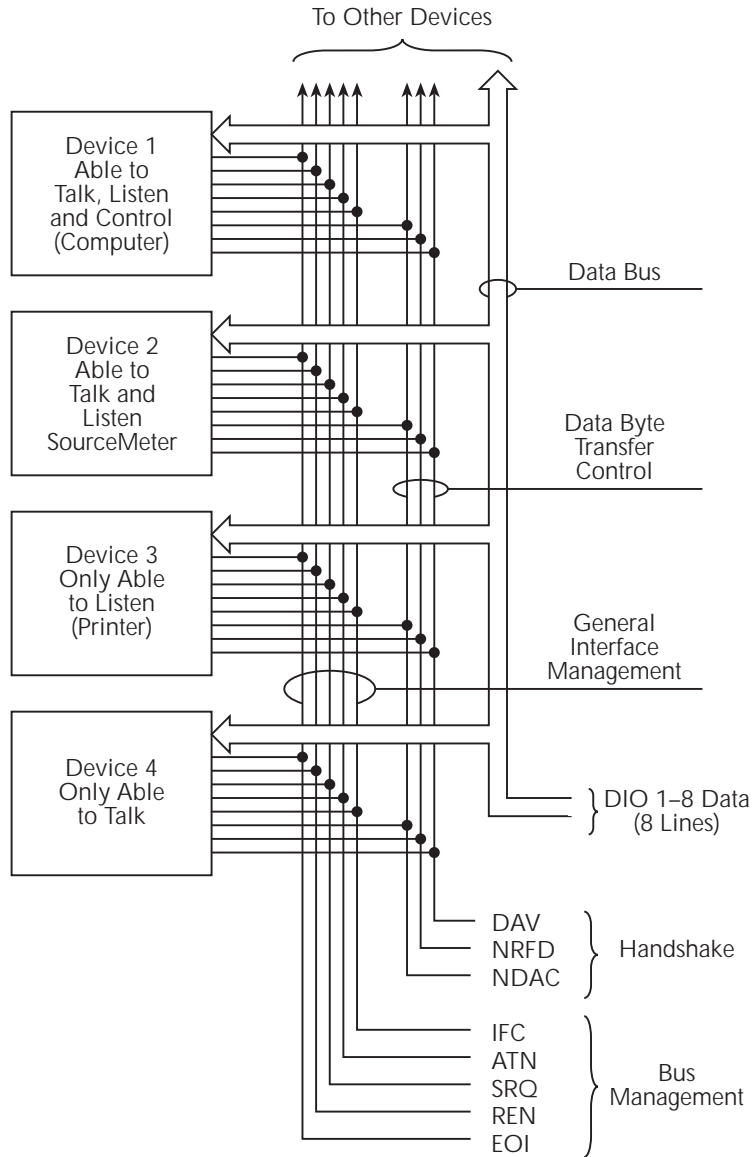

Bus lines

The signal lines on the IEEE-488 bus are grouped into three different categories: data lines, management lines, and handshake lines. The data lines handle bus data and commands, while the management and handshake lines ensure that proper data transfer and operation takes place. Each bus line is active low, with approximately zero volts representing a logic 1 (true). The following paragraphs describe the operation of these lines.

Data lines

The IEEE-488 bus uses eight data lines that transfer data one byte at a time. DIO1 (Data Input/Output) through DIO8 (Data Input/Output) are the eight data lines used to transmit both data and multiline commands and are bidirectional. The data lines operate with low true logic.

Bus management lines

The five bus management lines help to ensure proper interface control and management. These lines are used to send the uniline commands.

ATN (Attention) — The ATN line is one of the more important management lines. The state of this line determines how information on the data bus is to be interpreted.

IFC (Interface Clear) — As the name implies, the IFC line controls clearing of instruments from the bus.

REN (Remote Enable) — The REN line is used to place the instrument on the bus in the remote mode.

EOI (End or Identify) — The EOI is usually used to mark the end of a multi-byte data transfer sequence.

SRQ (Service Request) — This line is used by devices when they require service from the controller.

Handshake lines

The bus handshake lines operate in an interlocked sequence. This method ensures reliable data transmission regardless of the transfer rate. Generally, data transfer will occur at a rate determined by the slowest active device on the bus.

One of the three handshake lines is controlled by the source (the talker sending information), while the remaining two lines are controlled by accepting devices (the listener or listeners receiving the information). The three handshake lines are:

DAV (DATA VALID) — The source controls the state of the DAV line to indicate to any listening devices whether or not data bus information is valid.

NRFD (Not Ready For Data) — The acceptor controls the state of NRFD. It is used to signal to the transmitting device to hold off the byte transfer sequence until the accepting device is ready.

NDAC (Not Data Accepted) — NDAC is also controlled by the accepting device. The state of NDAC tells the source whether or not the device has accepted the data byte.

Figure D-2
IEEE-488 handshake sequence

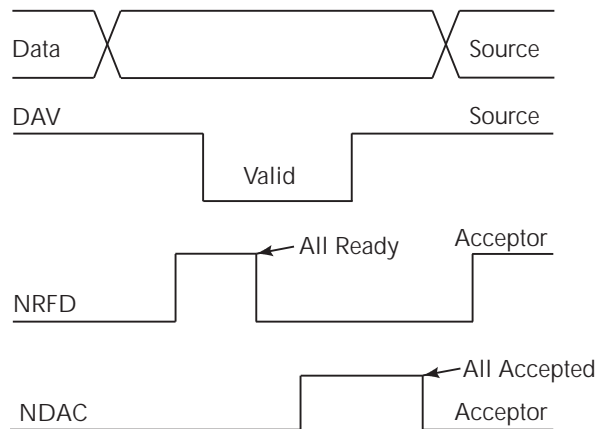

Bus commands

The instrument may be given a number of special bus commands through the IEEE-488 interface. This section briefly describes the purpose of the bus commands which are grouped into the following four categories.

1. Uniline commands — Sent by setting the associated bus lines true. For example, to assert REN (Remote Enable), the REN line would be set low (true).
2. Multiline commands — General bus commands which are sent over the data lines with the ATN line true (low).
3. Common commands — Commands that are common to all devices on the bus; sent with ATN high (false).
4. SCPI commands — Commands that are particular to each device on the bus; sent with ATN (false).

These bus commands and their general purpose are summarized in [Table D-1](#).

Table D-1
IEEE-488 bus command summary

Command type	Command	State of ATN line	Comments
Uniline	REN (Remote Enable)	X	Set up devices for remote operation.
	EOI	X	Marks end of transmission.
	IFC (Interface Clear)	X	Clears interface.
	ATN (Attention)	Low	Defines data bus contents.
	SRQ	X	Controlled by external device.
Multiline Universal	LLO (Local Lockout)	Low	Locks out local operation.
	DCL (Device Clear)	Low	Returns device to default conditions.
	SPE (Serial Enable)	Low	Enables serial polling.
	SPD (Serial Poll Disable)	Low	Disables serial polling.
Addressed	SDC (Selective Device Clear)	Low	Returns unit to default conditions.
	GTL (Go To Local)	Low	Returns device to local.
Unaddressed	UNL (Unlisten)	Low	Removes all listeners from the bus.
	UNT (Untalk)	Low	Removes any talkers from the bus.
Common	–	High	Programs IEEE-488.2 compatible instruments for common operations.
SCPI	–	High	Programs SCPI compatible instruments for particular operations.

Addressed multiline commands

Addressed commands are multiline commands that must be preceded by the device listen address before that instrument will respond to the command in question. Note that only the addressed device will respond to these commands. Both the commands and the address preceding it are sent with ATN true.

Address commands

Addressed commands include two primary command groups and a secondary address group. ATN is true when these commands are asserted.

Unaddress commands

The two unaddress commands are used by the controller to remove any talkers or listeners from the bus. ATN is true when these commands are asserted.

Common commands

Common commands are commands that are common to all devices on the bus. These commands are designated and defined by the IEEE-488.2 standard.

Generally, these commands are sent as one or more ASCII characters that tell the device to perform a common operation, such as reset. The IEEE-488 bus treats these commands as data in that ATN is false when the commands are transmitted.

SCPI commands

SCPI commands are commands that are particular to each device on the bus. These commands are designated by the instrument manufacturer, and are based on the instrument model defined by the Standard Commands for Programmable Instruments (SCPI) Consortium's SCPI standard.

Generally, these commands are sent as one or more ASCII characters that tell the device to perform a particular operation, such as setting a range or closing a relay. The IEEE-488 bus treats these commands as data in that ATN is false when the commands are transmitted.

Command codes

Command codes for the various commands that use the data lines are summarized in [Figure D-3](#). Hexadecimal and the decimal values for the various commands are listed in [Table D-2](#).

Table D-2

Hexadecimal and decimal command codes

Command	Hex value	Decimal value
GTL	01	1
SDC	04	4
GET	08	8
LLO	11	17
DCL	14	20
SPE	18	24
SPD	19	25
LAG	20-3F	32-63
TAG	40-5F	64-95
SCG	60-7F	96-127
UNL	3F	63
UNT	5F	95

IEEE command groups

Command groups supported by the SourceMeter are listed in [Table D-3](#). Common commands and SCPI commands are not included in this list.

Table D-3

IEEE command groups

HANDSHAKE COMMAND GROUP	
	NDAC = NOT DATA ACCEPTED NRFD = NOT READY FOR DATA DAV = DATA VALID
UNIVERSAL COMMAND GROUP	
	ATN = ATTENTION DCL = DEVICE CLEAR IFC = INTERFACE CLEAR REN = REMOTE ENABLE SPD = SERIAL POLL DISABLE SPE = SERIAL POLL ENABLE
ADDRESS COMMAND GROUP	
LISTEN	LAG = LISTEN ADDRESS GROUP MLA = MY LISTEN ADDRESS UNL = UNLISTEN
TALK	TAG = TALK ADDRESS GROUP MTA = MY TALK ADDRESS UNT = UNTALK OTA = OTHER TALK ADDRESS
ADDRESSED COMMAND GROUP	
	ACG = ADDRESSED COMMAND GROUP GTL = GO TO LOCAL SDC = SELECTIVE DEVICE CLEAR
STATUS COMMAND GROUP	
	RQS = REQUEST SERVICE SRQ = SERIAL POLL REQUEST STB = STATUS BYTE EOI = END

Interface function codes

The interface function codes, which are part of the IEEE-488 standards, define an instrument's ability to support various interface functions and should not be confused with programming commands found elsewhere in this manual. The interface function codes for the SourceMeter are listed in [Table D-4](#).

Table D-4

SourceMeter interface function codes

Code	Interface function
SH1	Source Handshake capability
AH1	Acceptor Handshake capability
T5	Talker (basic talker, serial poll, unaddressed to talk on LAG)
L4	Listener (basic listener, unaddressed to listen on TAG)
SR1	Service Request capability
RL1	Remote/Local capability
PP0	No Parallel Poll capability
DC1	Device Clear capability
DT1	Device Trigger capability
C0	No Controller capability
E1	Open collector bus drivers
TE0	No Extended Talker capability
LE0	No Extended Listener capability

E

IEEE-488 & SCPI Conformance Information

Introduction

The IEEE-488.2 standard requires specific information about how the SourceMeter implements the standard. Paragraph 4.9 of the IEEE-488.2 standard (Std 488.2-1987) lists the documentation requirements. [Table E-1](#) provides a summary of the requirements, and provides the information or references the manual for that information. [Table E-2](#) lists the coupled commands used by the SourceMeter.

The SourceMeter complies with SCPI version 1996.0. [Table 18-1](#) through [Table 18-11](#) list the SCPI confirmed commands and the non-SCPI commands implemented by the SourceMeter.

Table E-1
IEEE-488 documentation requirements

	Requirements	Description or reference
(1)	IEEE-488 Interface Function Codes.	See Appendix D .
(2)	Behavior of SourceMeter when the address is set outside the range 0-30.	Cannot enter an invalid address.
(3)	Behavior of SourceMeter when valid address is entered.	Address changes and bus resets.
(4)	Power-On Setup Conditions.	Determine by :SYSTEM:POSetup (Section 18).
(5)	Message Exchange Options:	
(a)	Input buffer size.	2048 bytes.
(b)	Queries that return more than one response message unit.	None.
(c)	Queries that generate a response when parsed.	All queries (Common Commands and SCPI).
(d)	Queries that generate a response when read.	None.
(e)	Coupled commands.	See Table E-2 .
(6)	Functional elements required for SCPI commands.	Contained in SCPI command sub-systems tables (see Table 18-1 through Table 18-11).
(7)	Buffer size limitations for block data.	Block display messages: 32 characters max.
(8)	Syntax restrictions.	See Section 14 , "Programming syntax."
(9)	Response syntax for every query command.	See Section 14 , "Programming syntax."
(10)	Device-to-device message transfer that does not follow rules of the standard.	None.
(11)	Block data response size.	See Section 18 , "FORMat subsystem."
(12)	Common Commands implemented by SourceMeter.	See Section 16 , "Common Commands."
(13)	Calibration query information.	See Service Manual.
(14)	Trigger macro for *DDT.	Not applicable.
(15)	Macro information.	Not applicable.
(16)	Response to *IDN (identification).	See Section 16 , "Common Commands."
(17)	Storage area for *PUD and *PUD?.	Not applicable.
(18)	Resource description for *RDT and *RDT?.	Not applicable.
(19)	Effects of *RST, *RCL and *SAV.	See Section 16 , "Common Commands."
(20)	*TST information.	See Section 16 , "Common Commands."
(21)	Status register structure.	See Section 15 , "Status Structure."
(22)	Sequential or overlapped commands.	All are sequential except :INIT.
(23)	Operation complete messages.	*OPC, *OPC? and *WAI; see Section 16 , "Common Commands."

Table E-2
Coupled commands

Command	Also changes
:SENSe...:RANGe:UPPER :SENSe...:NPLC :SOURce...:RANGe :SOURce...:STARt :SOURce...:STOP :SOURce...:STEP :SOURce...:POINts :SOURce...:CENTer :SOURce...:SPAN REN, GTL :SYSTem:MEMory:INITialize	:SENSe...:RANGe:AUTO NPLC for all other functions :SOURce...:RANGe:AUTO :SOURce...:STEP :SOURce...:CENTer :SOURce...:SPAN :SOURce...:STEP :SOURce...:CENTer :SOURce...:SPAN :SOURce...:POINts :SOURce...:STEP :SOURce...:STARt :SOURce...:STOP :SOURce...:STEP :SOURce...:STARt :SOURce...:STOP :SOURce...:STEP See local and remote transition in Section 14 , “Differences: remote vs. local operation.” See command description in Section 18 , “SYSTem subsystem.”

... = Valid function command words (i.e., :VOLT:DC, :VOLT:AC, etc.)

F

Contact Check Function

Introduction

This appendix contains information on the contact check function available with the Models 2400-C, 2410-C, 2420-C, 2425-C, 2430-C, and 2440-C SourceMeters.

Overview

Description

The contact check function prevents measurements that may be in error due to excessive resistance in the force or sense leads when making remotely sensed (Kelvin) measurements. There are many potential sources for this resistance, including poor contact at the DUT, failing relay contacts on a switching card, and wires that are too long or thin. This is shown schematically in [Figure F-1](#), where R_C is the resistance of the mechanical contact at the DUT, and R_S is the series resistance of relays and cables. The contact check process performs a differential resistance measurement between each source lead and its corresponding sense (Kelvin) lead. The resultant resistance is then compared to the programmed limit and a pass or fail result is determined. This process takes place in as short as 350uS and delivers no energy to the device under test.

Figure F-1
Source of Kelvin resistance errors

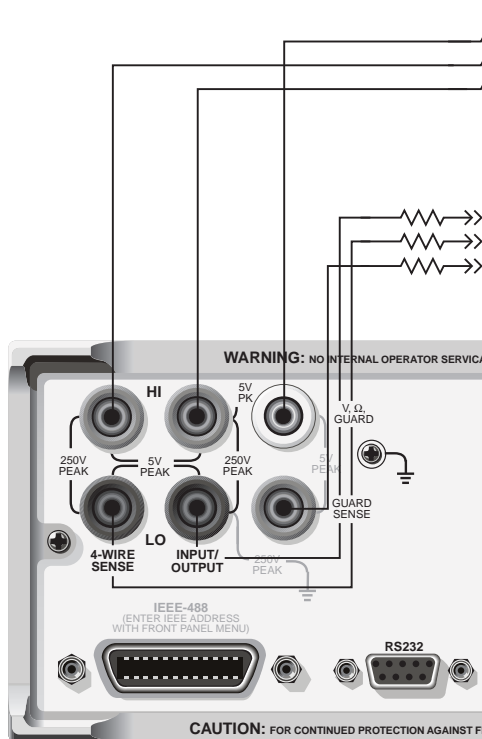

Operation

DUT connections

The contact check function can be used to verify satisfactory contact resistance to the DUT at both the front and rear panels. If you do not wish to perform contact check using the GUARD/GUARD SENSE jacks (on the rear panel), they must be shorted together for proper contact check. The SourceMeter must be placed into remote sense (4-wire) mode for contact check to function. If in 2-wire mode, contact check can be enabled but will not be performed.

All three source/sense pairs are tested when contact check is enabled. If a source/sense pair is not used in a particular test, it must have a shorting plug installed. Other than this requirement, normal connections to the DUT should be made as shown in [Figure F-2](#).

Figure F-2
Contact check DUT connections

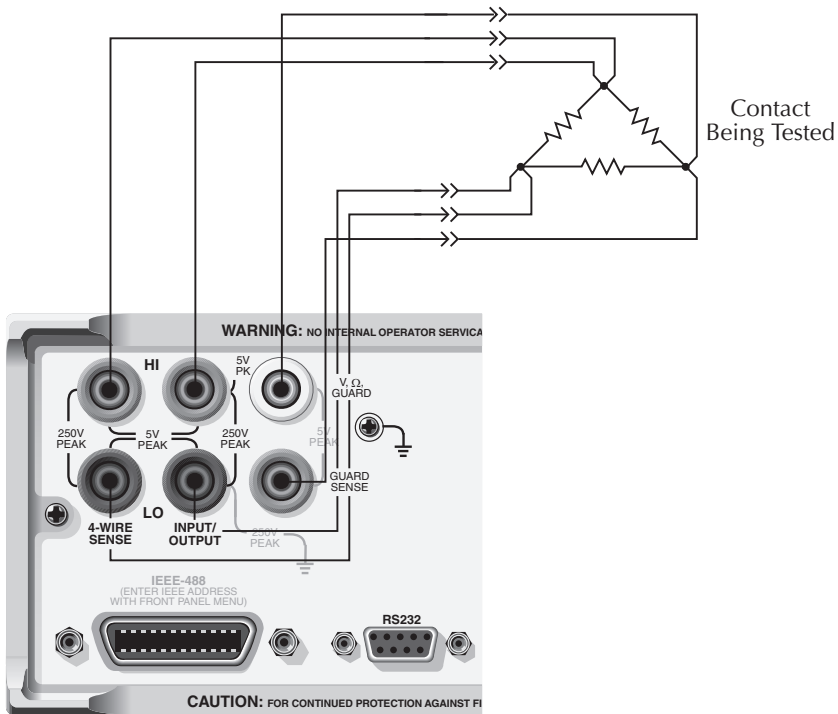

Note: Jumper V, Ω, GUARD, and GUARD SENSE when not using during measurement. Otherwise, a contact check failure will occur.

Contact check threshold resistances

There are three different threshold resistances available for contact check: 2Ω, 15Ω, and 50Ω (The factory default is 50Ω). These threshold values were chosen to ensure that contact failures would be detected reliably. [Table F-1](#) summarizes recommended threshold values based on the resistance of the device-under-test.

A contact check pass condition occurs when the resistance of the device-under-test connection paths are less than the selected threshold resistance value.

Table F-1
Recommended contact resistance threshold values

Nominal DUT Resistance	Threshold
2Ω	2Ω
20Ω	2Ω or 15Ω
200Ω or higher	2Ω, 15Ω, or 50Ω

Contact check failure indications

There are several options to handle failure conditions detected by contact check:

- Via trigger system
- The front panel display shows “OPEN LEAD.”
- User-defined bits can be set on the Digital I/O port for LIMIT 4 (one of the hardware limits in the Digital I/O control scheme) as controlled from the front panel or with :CALCulate2:LIMit4 commands. (See “[Front panel contact check operation](#),” page F-11, and “[Remote contact check operation](#),” page F-14.)
- Bit 18 of the 24-Bit Status word is set if there is an open lead and can be read over the GPIB or RS-232 port, if LIMIT 4 is enabled. Pass/Fail status for that limit is also contained in the status word. (See “[FORMat sub-system](#),” page 18-47.)
- Bit 10 of the Measurement Condition and Measurement Event Registers are set if a contact check failure occurs. You can use a Service Request (SRQ) to query the state of these bits. (See “[Measurement Event Register](#),” page 15-13 and [Figure 15-6](#).)

Auto and manual ohms

Contact check can be used with either the auto or manual ohms modes. See “[Ohms measurement procedure](#),” page 4-4 for more information.

Trigger model operation

Contact check can be used with the SourceMeter trigger system to delay or completely prevent progression through the trigger model unless the contact check is in a pass state. In relation to the standard trigger models (Figure 11-1 and Figure 11-8), the contact check test is performed just before the SOURCE Action block in the trigger layer.

NOTE For the Model 2430 Pulse Mode, the trigger models are shown as shown in Figure 11-8 and Figure 11-9.

As with other trigger model operations, there is an event detector for contact check. With contact check event detection enabled, operation will hold up at the detector until contact check is performed, and/or a specified timeout period expires. If contact check passes, event detection is satisfied allowing operation to move on to perform the SOURCE Action. If contact check fails (open lead condition), the SourceMeter will wait for the set timeout period to expire before issuing an open lead failure and moving on to perform the SOURCE Action. The contact check timeout can be set from 0.00000 to 999.99990 seconds. Note, however, that setting the timeout to 0 seconds disables the timeout. That is, operation will be held up indefinitely until contact check detection occurs.

With contact check event detection disabled, operation will not hold up at the contact check event detector and wait for contact check to be performed. In other words, event detection is satisfied immediately. If contact check is disabled, or the SourceMeter is in 2-wire sense mode, event detection is disabled.

Sweep and binning considerations

Sweep limitations

Staircase and custom sweeps

Auto ohms cannot be used with staircase and custom sweeps. To use these types of sweeps with contact check, you must use the manual ohms mode.

Source memory sweeps

The contact check function is enabled globally, rather than for individual source memory locations (see “Source memory sweep,” page 10-6). However, it is still possible to mix both 2-wire and 4-wire sense modes in the same Source memory list. When enabled before the start of a sweep, contact check will be automatically performed for the memory locations using 4-wire (remote) sense, but not for locations using 2-wire (local) sense.

Limit test sequence

When enabled, the contact check limit test (Limit 4) is performed before all other limit tests, as shown in [Figure F-3](#). [Figure F-4](#) shows a flowchart for grading mode limit testing with contact check limit testing enabled, while [Figure F-5](#) shows a flowchart for sorting mode limit testing, again with contact check limit testing enabled. See [Section 12](#) for complete details on other limit tests.

Figure F-3

Contact check limit test sequence

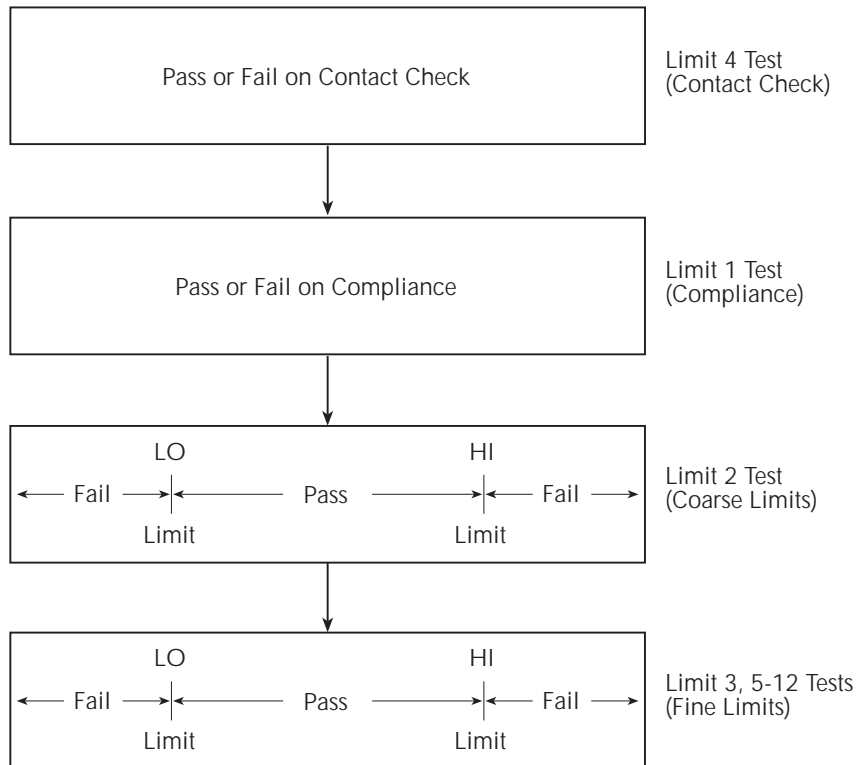
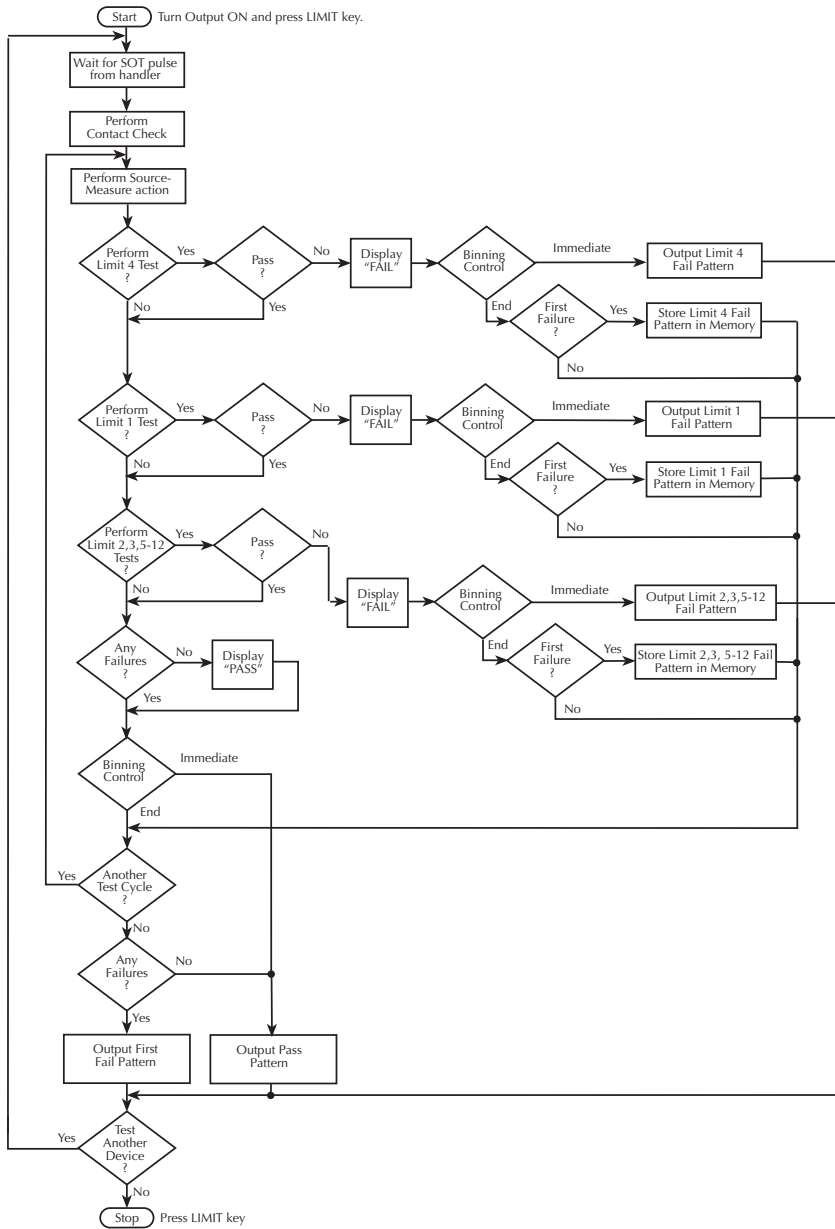
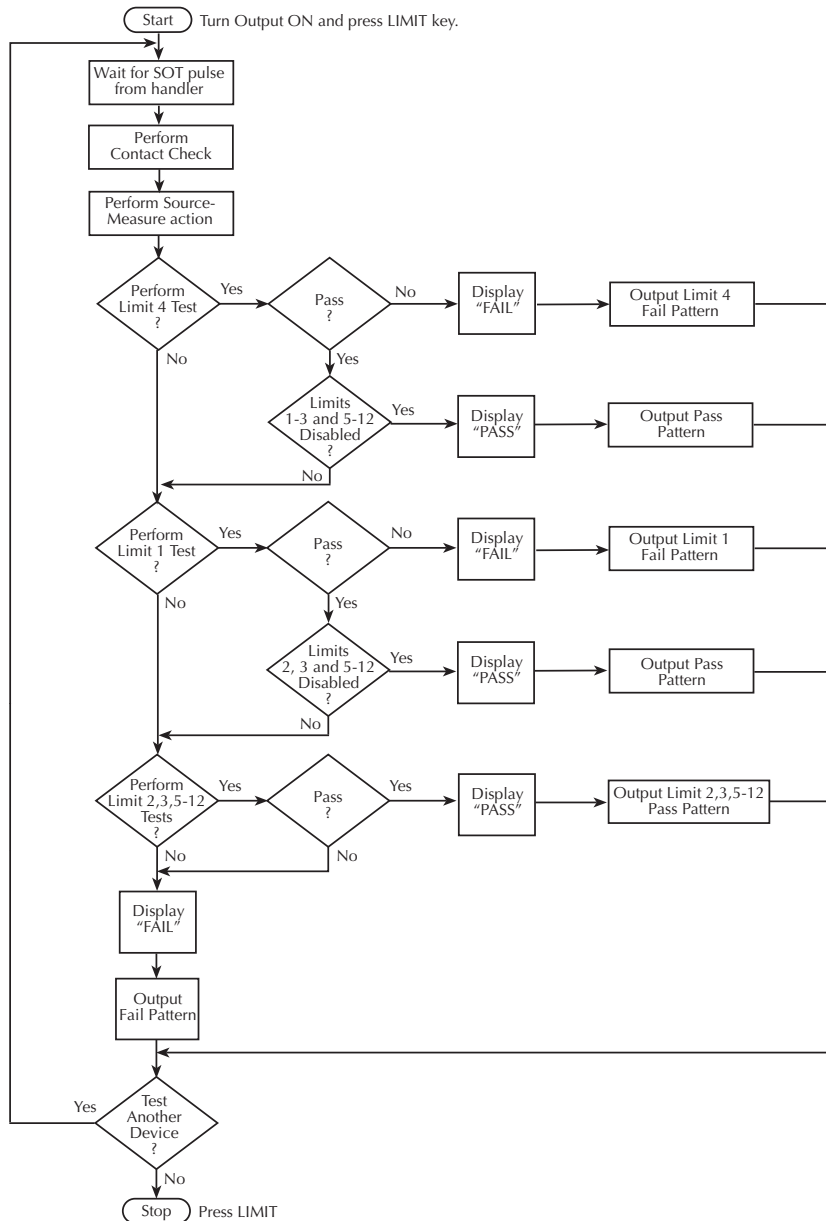

Figure F-4
Grading mode contact check limit testing



NOTE Enabling contact check does not automatically enable LIMIT 4. LIMIT 4 must be explicitly enabled from the front panel or using the :CALC2 subsystem commands. See “Front panel contact check operation,” page F-11, or “Remote contact check operation,” page F-14 for more details.

Figure F-5
Sorting mode contact check limit testing



Enabling contact check does not automatically enable LIMIT 4. LIMIT 4 must be explicitly enabled from the front panel or using the :CALC2 subsystem commands. See “Front panel contact check operation,” page F-11, or “Remote contact check operation,” page F-14 for more details.

Binning failure indications (grading mode)

As previously discussed, it is possible to place a fail pattern on the Digital I/O Port when contact check fails. It is important to note that, depending on whether source auto clear is enabled and when the bin control is done, certain issues arise when running a test with a normal voltage or current sweep and a source memory sweep. Four possible effects on sweep operation may occur when using the digital output and contact check. Refer to [“Binning systems,” page 12-10](#), for a description of binning and to [“Front panel output configuration,” page 13-7](#), for details on source auto off functionality.

When performing a source memory sweep with the SourceMeter, contact check is performed before each point in that sweep only when 4-wire remote sensing is enabled. To save test cycle time, the contact check is performed before the memory location for the sweep point is recalled. If there is a failure in any of the four modes below, the sweep memory location containing the open lead will not be recalled from the memory.

Auto clear on, end binning

Source auto clear on: :SOUR:CLE:AUTO ON
Bin control at end of sweep: :CALC2:CLIM:BCON END

If a point in a sweep operation fails contact check, the output is turned off and will remain off until the end of the sweep points. The triggers will be supplied and accepted to maintain timing. The memory for each of the points after the failure will not be recalled, and no further contact checks will be performed until the end of the sweep points. If the sweep is to be repeated, the new sweep will start with a contact check, and normal measurement operation will resume.

Auto clear on, immediate binning

Bin control at end of each point sweep: :CALC2:CLLM:BCON IMM

If contact check detects an open lead, the output is not turned on for that particular location, and that sweep point is not recalled and will be skipped. The sweep proceeds to the next sweep point, and a contact check test is performed.

Auto clear off, end binning

Source auto clear off: :SOUR:CLE:AUTO OFF
Bin control occurring at end of sweep: :CALC2:CLIM:BCON END

The output is kept on throughout the entire sweep. If an open lead is found during the sweep, the output is turned off, no more contacts are checked, sweep memory locations are not recalled, and triggers are maintained until the last sweep point. If multiples of the same sweep are desired, the following sweep after the open lead

will start with a contact check for each sweep point and normal measurement operation if no other failures occur.

Auto clear off, immediate binning

Bin control at end of each point is sweep: :CALC2:CLIM:BCON IMM

The output will remain on between each sweep point if no contact check failure occurs. If a contact check failure occurs before the execution of a sweep point, the output will be turned off for that point. The test sequence will progress and perform a contact check on the next point in the sweep. The output will not be turned on until a good contact is detected.

Front panel contact check operation

Menu selections

[Table F-2](#) summarizes the menu selections for various contact check modes. Note that only those selections specific to contact check operation are shown here. See [Section 1](#) for complete menu listings, and [Section 11](#) and [Section 12](#) for details on triggering and limit testing, respectively.

Table F-2
Contact check menu selections

Menu item*	Description
CONFIG LIMIT	Configure limit tests.
CONFIGURE LIMITS MENU	
DIGOUT	Set Digital I/O modes.
SIZE	Select 3-BIT or 4-BIT fail pattern size.
MODE	Select GRADING or SORTING mode.
H/W LIMITS	Control and set mode for Limit 1 and Limit 4 tests.
LIMIT1(CMPL)	Select Limit 1 (compliance) test.
LIMIT4(CCHK)	Select Limit 4 (contact check) test.
CONTROL	Enable/disable Limit 4 test.
DISABLE	Disable contact check limit test.
ENABLE	Enable contact check limit test.
DIGIO PATTERN	Set contact check Digital I/O pattern. Default Setting:0-7, 3-bit, alternately 0-15, 4-bit.

Table F-2 (cont.)

Contact check menu selections

Menu item*	Description
MENU	Main menu.
MAIN MENU	
A/D CTRL	A/D control selection.
AUTO ZERO	
LINE FREQ	
NPLC CACHE	Control NPLC caching.
CONT CHK	Enable/disable contact check.
DISABLE	Disable contact check.
ENABLE	Enable contact check, select 2Ω, 15Ω, or 50Ω resistance.
CONFIG TRIG	Configure triggering.
CONFIGURE TRIGGER	
ARM LAYER	Configure arm layer.
TRIG LAYER	Configure trigger layer.
HALT	Return to idle.
CONTACT CHECK	Configure contact check event detection.
DISABLE	Disable contact check event detection.
ENABLE	Enable contact check event detection, program contact check timeout (0.00000 to 999.99990).
CONFIG SOURCE V or CONFIG MEAS Ω	Configure 4-wire sense mode for contact check.
SENSE MODE	Select sense mode.
2 WIRE	2-wire sensing.
4 WIRE	4-wire sensing (use for contact check).

* See [Section 1](#) for complete menu listings, and [Section 11](#) and [Section 12](#) for triggering and limit tests. Factory defaults shown in boldface.

Using contact check

1. Make connections to the DUT ([Figure F-2](#)).
2. Press the MENU key, select A/D CTRL, then choose CONT CHK, and press ENTER.
3. Select ENABLE, then press ENTER.
4. At the CONT-CHK RESISTANCE prompt, select the desired contact check threshold resistance (2Ω, 15Ω, or 50Ω), then press ENTER. (See [Table F-1](#) for recommendations.)
5. Use EXIT to back out of the menu structure.
6. Press CONFIG then Ω then select SENSE MODE, and press ENTER. Alternately, you can press CONFIG V SOURCE and select SENSE-MODE, or

by pressing CONFIG V MEAS and selecting SENSE-MODE. These settings are all interrelated.

7. Select 4 WIRE, then press ENTER.
8. Press EXIT to return to normal display.
9. Observe the display for an "OPEN LEAD" message when the contact check fails.

Using event detection with contact check

1. Enable contact check as previously explained.
2. Press CONFIG then TRIG.
3. Select CONTACT CHECK, then press ENTER.
4. Select ENABLE, then press ENTER.
5. Set the contact check timeout, then press ENTER.
6. Use the EXIT key to back out of the menu structure.

Using pass/fail with contact check

1. Enable contact check as previously explained.
2. Press CONFIG then LIMIT.
3. Select DIGOUT, then press ENTER.
4. Select SIZE, then press ENTER.
5. Select fail pattern size (3-BIT or 4-BIT), then press ENTER.
6. Select MODE, then press ENTER.
7. Select the limit testing mode (GRADING or SORTING), then press ENTER:
 - a. Grading — After selecting GRADING, select IMMEDIATE or END binning, then press ENTER.
 - b. Sorting — After selecting SORTING, you will be prompted to set the fail pattern for Limit 2, 3, 5-12 tests (0-7 for 3-bit, or 0 to 15 for 4-bit), then press ENTER. This setting is only significant if performing Limit 2, 3, 5-12 tests (see [Section 12](#) for details).
8. Press EXIT, select H/W LIMITS, then press ENTER.
9. Select LIMIT4(CCHK), then press ENTER.
10. Select CONTROL, then press ENTER.
11. Select ENABLE, then press ENTER.
12. Select DIGIO PATTERN, then press ENTER.
13. Set the output fail pattern, as desired, for when the contact check (Limit 4) fails (0 to 7; 3-bit or 0 to 15; 4-bit).
14. Use the EXIT key to return to the normal display.
15. Press LIMIT to enable limit testing, and observe the display for a PASS or FAIL message when the contact check passes or fails respectively.

Remote contact check operation

Contact check remote commands

Table F-3 summarizes contact check remote commands. Commands specific to contact check operation are covered in detail later in this appendix, while remaining commands are covered in [Section 18](#).

Table F-3

Contact check remote commands

Command	Description
*OPT? :SOURce2 :BSIZe 3 4 :BSIZe? :CALCulate2 :CLIMits :MODE GRADING SORTING :MODE? :BCONtrol IMMEDIATE END :BCONtrol? :LIMit4 :STATe ON OFF :STATe?	Queries installed options. Response message indicates the presence or absence of options. For example: 0 No options present CONTACT-CHECK Contact check board present Set digital I/O port bit size; 3 or 4. Query bit size of digital I/O port. Selects limit testing mode; grading or sorting (Figure F-4 and Figure F-5). Query limit testing mode. Selects binning control for grading mode; immediate (at failure) or end (of sweep). Query binning control mode. Bit 10 of the Measurement Event Register represents the result of the LIMit4 test. Enables or disables contact check. If there is an open lead, the limit test fails. LIMit4 is performed before all other limit tests. Query contact check pass/fail state.
:CALCulate2 :LIMIT4 :SOURce2<NRf> :SOURce2? :FAIL?	Pattern to be placed on the I/O lines if Limit4 test fails; <NRf> = 0 to 7 for 3-bit, or 0 to 15 for 4-bit. Query I/O pattern for Limit4 test failure. Query if contact check failed (1 = fail). Specify the STATus data element.
:FORMat:ELEMents:CALCulate STATus	Bit 18 (262144) of the status word returned by READ?, FETCH?, MEASure?, MEASure:VOLTage?, MEASure:CURRent?, MEASure:RESistance?, TRACe:DATA?, CALCulate1:DATA?, or :CALCulate2:DATA? signifies the status of contact check (1 = open lead, 0 = OK). If LIMIT 4 is enabled, then pass/fail status for that limit is also returned.

Table F-3 (cont.)

Contact check remote commands

Command	Description
:SYSTem:RSENse ON	Enable 4-wire remote sense for contact check.
:SYSTem:RSENse?	Query sense selection.
:SYSTem:CCHeck ON OFF	Enable/disable contact checking.
:SYSTem:CCHeck?	Query state of contact check test.
:SYSTem:CCHeck:RESistance <NRf>	Select threshold resistance (0 to 60):
	<NRf> = 0 to 2 Selects 2W threshold resistance
	= >2 to 15 Selects 15W threshold resistance
	= >15 to 60 Selects 50W threshold resistance
:SYSTem:CCHeck:RESistance?	Query threshold resistance.
:TRIGger:SEQuence2:SOURce <name>	Enable or disable contact check event detection; <name> =
	CCHeck (enable) or IMMEDIATE (disable).
:TRIGger:SEQuence2:SOURce?	Query state of event detection.
:TRIGger:SEQuence2:TOUT <NRf>	Specify contact check timeout in seconds (0.00000 to
	999.99990).
:TRIGger:SEQuence2:TOUT?	Query contact check timeout setting.

*RST and SYSTem:PRESet parameter defaults are shown in boldface.

Contact check programming example

Table F-4 summarizes a basic contact check programming example.

Table F-4
Contact check programming example

Command	Description
*RST :SYST:CCH ON :SYST:CCH:RES 2 :SYST:RSEN ON :CALC2:LIM4:STAT ON :CALC2:LIM4:SOUR2 15 *:SENS:FUNC "RES" :TRIG:SEQ2:SOUR CCH :TRIG:SEQ2:TOUT 2 :OUTP ON :INIT :CALC2:LIM4:FAIL?	Restore GPIB defaults. Enable contact check. Set 2Ω contact resistance. Enable 4-wire remote sense. Enable contact check pass/fail. Set Digital I/O bits all HI on failure. *Select ohms function. Enable contact check event detection. Set 2 second contact check timeout. Turn on output. Trigger unit. Query contact check pass/fail.

*NOTE: ":SENS:FUNC 'RES'" selects ohms as the measurement function but is optional. Alternately, you could select any of the other valid measurement operations.

Contact check command reference

Configure and control contact check

CCheck

	:SYSTem:CCheck 	Enable or disable contact check.
Parameters	 = 0 or OFF 1 or ON	Disable contact check Enable contact check
Query	:CCheck?	Query state of contact check
Description	This command is used to enable or disable contact check. When using contact check, remote sensing must be enabled (:SYST:RSEN ON).	

RESistance <NRf>

	:SYSTem:CCheck:RESistance <NRf>	Set contact check threshold resistance.
Parameters	<NRf> = 0 - 60 0 to 2 = 2Ω >2 to 15 = 15Ω >15 to 60 = 50Ω	2Ω, 15Ω, or 50Ω threshold resistance
Query	:RESistance?	Query contact check threshold resistance
Description	This command sets the contact threshold resistance value. (Factory default = 50Ω) The contact check function will indicate a failure when the connection path resistance is greater than the programmed value.	

Configure and control contact check limit test

STATe

	:CALCulate2:LIMit4:STATe 	Control LIMIT 4 test
Parameters	 = 1 or ON 0 or OFF	Enable Limit 4 test Disable Limit 4 test
Query	:STATe?	Query state of Limit 4 test
Description	This command enables or disables the LIMIT 4 (contact check) test. When the limit test is enabled, the Digital I/O port bit pattern can be controlled by the results of the test. (See " SOURCE2 <NRf> <NDN> ," page F-18.)	

FAIL?

:CALCulate2:LIMit4:FAIL?

Read LIMIT 4 test result

Description This command is used to read the results of the LIMIT 4 test:

0 = Limit 4 test passed

1 = Limit 4 test failed

NOTE *Reading the results of the limit test does not clear the fail indication of the test. A failure can be cleared by sending a :SYSTem:CLEar command.*

SOURce2 <NRf> |<NDN>

:CALCulate2:LIMit4:SOURce2 <NRf> |<NDN>

Specify pattern; LIMIT 4 failure

Parameters	<NRf> =	0 to 7 (3-bit)	Decimal value
		0 to 15 (4-bit)	Decimal value
	<NDN> =	0 to #b111 (3-bit)	Binary value
		0 to #b1111 (4-bit)	Binary value
		0 to #q7 (3-bit)	Octal value
		0 to #q17 (4-bit)	Octal value
		0 to #h7 (3-bit)	Hexadecimal value
		0 to #hF (4-bit)	Hexadecimal value

Query :SOURce2? Query source value for specified limit**Description** This command is used to define the digital output fail patterns for the Limit 4 test (0 to 7, 3-bit; 0 to 15, 4-bit).

Use the following table to determine the parameter value for the desired decimal digital output pattern. For non-decimal parameters, convert the decimal value to its binary, octal, or hexadecimal equivalent.

OUT 4*	OUT 3	OUT 2	OUT 1	Decimal value*
L	L	L	L	0
L	L	L	H	1
L	L	H	L	2
L	L	H	H	3
L	H	L	L	4
L	H	L	H	5
L	H	H	L	6
L	H	H	H	7
H	L	L	L	8
H	L	L	H	9
H	L	H	L	10
H	L	H	H	11
H	H	L	L	12
H	H	L	H	13
H	H	H	L	14
H	H	H	H	15

L = Low (Gnd)

H = High (>+3V)

* OUT 4 not used in 3-bit mode (values = 0 to 7)

Configure and control contact check event detection

SOURce <name>

:TRIGger:SEquence2:SOURce <name>

Enable/disable event detection

Parameters

<name> = IMMEDIATE
CCHeck

Disable contact check event detection
Enable contact check event detection

Query

:SOURce?

Query state of contact check event detection

Description

This command enables or disables the contact check event detection. When event detection is enabled, the unit will wait the specified timeout period ("TOUT <NRf>," [page F-20](#)) before issuing an open lead failure and moving on to the next measurement.

TOUT <NRf>

:TRIGger:SEQuence2:TOUT <NRf>

Specify contact check timeout

Parameters <NRf> = 0.00000 to 999.99990 (sec) Contact check timeout**Query** :TOUT? Query contact check timeout

Description This command programs the contact check timeout interval. When contact event detection is enabled (“**SOURce <name>**,” page F-19), the SourceMeter will wait the specified timeout period before issuing an open lead failure and moving on to the next measurement. If the timeout interval is set to 0 with contact event detection enabled, the unit will wait indefinitely.

Contact check defaults

Table F-5 summarizes default settings for various contact check modes along with the equivalent remote commands.

Table F-5

Contact check defaults

Mode	Default setting*	Remote command*
Contact check mode	Disabled	:SYSTem:CCheck OFF
Contact check threshold resistance	50Ω	:SYSTem:CCheck:RESistance 50
Limit 4 test	Disabled	:CALCulate2:LIMit4:STATe OFF
Limit 4 Digital I/O failure pattern	15	:CALCulate2:LIMit4:SOURce2 15
Contact check event detection	Disabled	:TRIGger:SEQuence2:SOURce IMMEDIATE
Contact check timeout	0	:TRIGger:SEQuence2:TOUT 0

*Bench (:SYSTem:PRESet) and GPIB (*RST) defaults are the same.

G GPIB 488.1 Protocol

Introduction

The SourceMeter supports two GPIB protocols: SCPI and 488.1. The 488.1 protocol is included to significantly increase speed over the GPIB.

When using the 488.1 protocol, throughput is enhanced up to 10 times for data sent to the SourceMeter (command messages) and up to 20 times for data returned by the Source-Meter (response messages). The speed of readings sent over the GPIB is also increased; see [“Multiple TALKs on the same query are supported as in the SCPI protocol. This feature is useful when reading back long ASCII strings.”](#) page G-5, for details.

NOTE With the 488.1 protocol selected, you will still use SCPI commands to program the SourceMeter. Operation differences between the two protocols are discussed in this appendix.

Selecting the 488.1 protocol

Perform the following steps to select the 488.1 protocol:

1. Press MENU to display the MAIN MENU.
2. Place the cursor on COMMUNICATION and press ENTER to display the COMMUNICATIONS SETUP menu.
3. Place the cursor on GPIB and press ENTER to display the present GPIB address.
4. Press ENTER to display the GPIB PROTOCOL menu.
5. Place the cursor on 488.1 and press ENTER.
6. Use the EXIT key to back out of the menu structure.

When switching between the SCPI protocol and 488.1 protocol, the instrument does not reset. The GPIB protocol setting is saved in EEPROM, and the unit will power up with that selected protocol.

The GPIB protocol cannot be changed over the bus. However, there is a query command to determine the presently selected protocol. When the 488.1 protocol is selected, the message exchange protocol (MEP) disables. Therefore, if you use the following query to request the state of MEP, you will know which protocol is enabled:

```
:SYSTem:MEP[:STATe]?
```

If a “1” is returned, MEP is enabled, and the SCPI protocol is selected. A “0” indicates that MEP is disabled, and the 488.1 protocol is enabled. To summarize:

1 = SCPI protocol

0 = 488.1 protocol

Protocol differences

The following information covers the differences between the 488.1 protocol and the SCPI protocol.

Message exchange protocol (MEP)

When the 488.1 protocol is selected, the MEP is disabled to speed up GPIB operation.

The following guidelines/limitations must be followed when using the 488.1 protocol:

- If a query is sent, it must be the only command on the line (this limitation also means no multiple queries can be sent). Otherwise, full SCPI command syntax is still supported including long-form and short form commands, multiple commands, and MIN/MAX/DEF parameter definitions.

For example, the following command strings are invalid:

```
:VOLT:RANG 10;*OPC?
```

```
:RES:RANG?:::READ?
```

```
:READ?:::READ?
```

The following command strings are valid:

```
:SOUR1:VOLTage:STARt 1;STOP 10;step 1
```

```
:volt:nplc 1.0::curr:rang min
```

```
:RES:RANG? MAX
```

```
:READ?
```

- When a query is sent, either the data must be read back or a Device Clear (DCL) or Interface Clear (IFC) must be performed to reset the query.
- When sending a command or query, do not attempt to read data from the SourceMeter until the terminator has been sent (usually Line Feed with EOI).
Otherwise, a DCL or IFC must be sent to reset the input parser.
- When receiving data, all data, up to and including the terminator (LF with EOI), must be accepted. Otherwise, a DCL or IFC must be sent to reset the output task.
- Empty command strings (terminator only) should not be sent.

Using SCPI-based programs

In general, an existing SCPI-based program will run properly and faster in the 488.1 protocol as long as it meets the above guidelines and limitations.

NRFD hold-off

*OPC, *OPC?, and *WAI are still functional but are not needed for the 488.1 protocol. When sending commands, the GPIB is automatically held off when it detects a terminator. The hold-off is released when all the commands have finished executing, or if there is some parser or command error. An exception is an initiate command, which releases the hold-off immediately and does not wait for all of the readings to be acquired. This immediate release of bus hold-off is done to support GET, SDC, IFC, *TRG, *RCL, *RST, SYSTem:PRESet, and ABORt during data acquisition.

NDAC hold-off

NDAC hold-off is included with the GPIB 488.1 protocol mode to allow a single instrument to hold off all others on the bus until it is finished executing a command. The following command controls NDAC hold-off:

```
SYSTem:MEP:HOLDoff ON | OFF
```

The default is OFF, but NRFD hold-off will still be enabled and will prevent an instrument from accepting further commands. See [Figure G-1](#) for the complete IEEE-488 handshake sequence.

Figure G-1
IEEE-488 handshake sequence

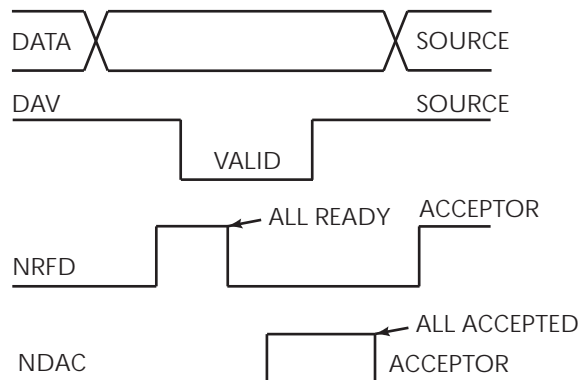

Trigger-on-talk

Trigger-on-talk functionality has been added for the 488.1 protocol. If a query has not been received by the instrument, the SourceMeter will automatically assume a READ? command has been sent when it is addressed to talk. This technique increases GPIB speed by decreasing the transmission and parser times for the command.

Trigger-on-talk is extremely useful in the single-shot reading mode (*RST default) and is the main reason for a >2x speed improvement over the SCPI protocol. Remember that the output must be on (:OUTput:STATE ON) before you can take readings.

The ARM:SOUR BUS and ARM:COUN INF commands are not supported by READ? with the 488.1 protocol selected. If you send one of these commands, a DCL or IFC may be required to reset the GPIB.

Message available

The MAV (message available) bit in the Serial Poll byte will be set when the query is finished being processed, not when there is data available in the output buffer (as with the SCPI protocol). For the 488.1 protocol, output data will not be formatted until the first request for data is received. This delay may cause unexpected time-outs when using SRQ on MAV for queries that take a long time to execute.

General operation notes

- The TALK, LSTN, and SRQ annunciators are not functional in the 488.1 protocol. This speeds up data throughput greatly. The REM annunciator still operates since it is critical to fundamental GPIB operation.
- If the unit is in REMote, the GTL command may not put the SourceMeter into the local mode. Only the front panel LOCAL key is guaranteed to operate, if not in local lockout (LLO). GTL will still disable LLO.
- IEEE-488 bus commands and features (GET, IFC, SDC, DCL, LLO, Serial Poll, and SRQ) are still fully supported.
- Multiple TALKs on the same query are supported as in the SCPI protocol. This feature is useful when reading back long ASCII strings.

Numerics

- 2-wire local sensing 2-7
- 4-wire remote sensing 2-7
- 6-wire ohms measurements 4-12

A

- Abort 10-5
- Accessories 1-3
- Acquiring readings 17-3
- Adapters 1-3
- Auto ohms measurements 4-4
- Auto ranging 7-3
- Auto zero 3-10
 - Disable/enable 5-11
 - Front panel 3-10
 - Remote command 3-10
- Auto-clear 12-14, 12-15

B

- Basic circuit configurations 3-9
 - Measure only (V or I) 6-25
 - Source I 6-23
 - Source V 6-24
- Binning 12-10
 - Basic systems 12-13
 - Contact check function F-6
 - Digital output clear pattern 12-14
 - Handler interface 12-10
 - Handler types 12-12
 - Multiple-element device 12-13
 - Single-element device 12-13
- Buffer considerations 6-36
- Bus commands
 - General 14-5

C

- Cable guard 2-8
- Cables 1-3
- Calculate subsystems 18-26
- Capabilities
 - Source-measure 3-4
- Carrying case 1-4
- Case sensitivity 14-9
- Circuit configurations
 - Basic 3-9
 - Measure only 6-25

Source I 6-23

Source V 6-24

Clearing registers and queues 15-4

Command reference

CALCulate[1] 18-26

CALCulate2 18-33

CALCulate3 18-43

Common 16-3

DISPlay subsystem 18-44

FORMat subsystem 18-47

OUTPut subsystem 18-55

ROUTe subsystem 18-57

SCPI 18-1

SENSe1 subsystem 18-58

SOURce subsystem 18-71

STATus subsystem 18-101

SYSTem subsystem 18-103

Tables 18-2

TRACe subsystem 18-114

TRIGger subsystem 18-116

Command summary

CALCulate 18-3

Common 16-2

DISPlay 18-8

FORMat 18-9

OUTPut 18-9

ROUTe 18-10

SCPI 17-2

SENSe 18-11

SOURce 18-15

STATus 18-20

TRACe 18-23

TRIGger 18-24

Command words 14-6

Commands

IEEE-4888 bus D-6

Common commands

*IDN? 16-3

*OPC 16-3

*OPC? 16-3

*RCL 16-3

*RST 16-4

*SAV 16-3

*TRG 16-4

*TST? 16-4

*WAI 16-5

Compliance

- Determining limit [6-4](#)
- Examples [6-4](#)
- Maximum values [6-3](#)
- Setting front panel compliance limit [3-8](#)
- Setting remote compliance limit [3-8](#)
- Types [6-2](#)
- Compliance limit [6-2](#)
 - Setting [3-8](#)
- compliance parameters [18-66](#), [18-67](#)
- Compliance range synchronization [3-8](#)
- Configuration measurement function [17-2](#)
- Configure OUTPUT menu [13-8](#)
- Connections [2-1](#)
- Connections to DUT [2-3](#)
- Contact check function [F-1](#)
 - Command reference [F-17](#)
 - Defaults [F-20](#)
 - Front panel operation [F-11](#)
 - Operation [F-3](#)
 - Programming example [F-15](#)
 - Remote operation [F-14](#)
 - Sweep and binning considerations [F-6](#)
- Cooling fan [1-12](#)
- Current [10-6](#)
- Current (measure) [3-20](#)
- Custom sweep [10-6](#), [10-16](#)

D

- Data flow [6-34](#), [C-1](#)
- Data store [9-1](#)
 - Buffer considerations [9-5](#)
 - Buffer statistics [9-3](#)
 - Front panel operation [9-2](#)
 - Programming example [9-5](#)
 - Recalling readings [9-2](#)
 - Remote operation [9-5](#)
 - Storing readings [9-2](#)
 - Timestamp accuracy [9-4](#)
 - Timestamp format [9-4](#)
- Digital I/O port [13-2](#)
 - Configuration [13-2](#)
 - Controlling output lines [13-4](#)
 - Output configuration [13-3](#)
- Digital output clear pattern [12-14](#)
- Digits [7-5](#)
- Display
 - Disabling [1-24](#)
 - Format [1-13](#)
 - Remote programming [1-14](#)

E

- EDIT key [1-13](#)
- Errors
 - Eliminating common SCPI errors [B-8](#)
- Examples
 - Contact check function programming example [F-15](#)
 - Custom sweep programming example [10-21](#)
 - Data store programming example [9-5](#)
 - Filter programming example [7-12](#)
 - Limit testing programming example [12-22](#)
 - Ohms programming example [4-14](#)
 - Output configuration programming example [13-12](#)
 - Program and read register set programming example [15-17](#)
 - Pulse-measure programming example [5-11](#)
 - Range and digits programming example [7-6](#)
 - Read error queue programming example [15-20](#)
 - Relative programming example [8-3](#)
 - Set MSS (B6) when error occurs programming example [15-10](#)
 - Source memory sweep programming example [10-23](#)
 - Source-measure programming example [3-19](#)
 - Staircase sweep programming example [10-19](#)
 - Triggering [11-20](#)
 - User-defined math function programming example [8-8](#)

F

- Factory default settings [1-16](#)
- Filter [7-9](#)
 - Front panel control [7-10](#)
 - Programming example [7-12](#)
 - Remote programming [7-12](#)
- Front panel operation
 - Auto zero [3-10](#)
 - Compliance limit [3-8](#)
 - Contact check function [F-11](#)
 - Data store [9-2](#)
 - Digital output control [13-5](#)
 - Filter [7-10](#)
 - GPIO [14-5](#)
 - Guard selection [2-13](#)

- Limit testing [12-19](#)
 - Math [8-6](#)
 - Menus [1-19](#)
 - Output configuration [13-7](#)
 - Pulse Mode configuration [5-10](#)
 - Pulse Mode sweep procedure [10-25](#)
 - Relative [8-2](#)
 - Sense selection [2-12](#)
 - Source delay [3-13](#)
 - Source-measure procedure [3-15](#)
 - Speed control [7-7](#)
 - Sweep [10-12](#)
 - Terminals selection [2-2](#)
 - Triggering [11-2](#)
 - V-source protection [3-12](#)
 - Front panel summary [1-6](#)
 - Front panel tests [1-14](#)
 - Front/rear terminals selection [2-2](#)
 - Fuse replacement [1-11](#)
- G**
- Getting started [1-1](#)
 - GPIB
 - Connections [14-4](#)
 - Front panel operation [14-5](#)
 - Operation [14-4](#)
 - Primary address [14-4](#)
 - Protocol differences [G-3](#)
 - Protocol selection [G-2](#)
 - Reading speed comparisons [G-5](#)
 - Standards [14-4](#)
 - Status indicators [14-5](#)
 - GPIB protocol [G-1](#)
 - Grading mode limits operation [12-4](#)
 - Guard [6-27](#)
 - Cable [2-8](#), [6-27](#)
 - Methods [2-8](#)
 - Ohms [2-9](#), [6-28](#)
 - Selection [2-13](#)
 - Sense [6-32](#)
 - Sense selection [2-12](#)
- H**
- Handler
 - Interface [12-10](#)
 - Types [12-12](#)
- I**
- IEEE-488 bus
 - Commands [D-6](#)
 - Description [D-3](#)
 - Interface function codes [D-12](#)
 - Lines [D-5](#)
 - Overview [D-1](#)
 - Inspection [1-3](#)
 - Interlock, see Output Enable [13-6](#)
 - I-Source operating boundaries [6-15](#)
- L**
- Limit 1 test (compliance) [12-3](#)
 - Limit 2 (course limits) [12-2](#)
 - Limit testing [12-1](#)
 - Binning [12-4](#)
 - Configuring [12-16](#)
 - Data flow [12-3](#)
 - Front panel operation [12-19](#)
 - Grading mode [12-4](#)
 - Modes [12-3](#)
 - Operation [12-4](#)
 - Pass/fail information [12-2](#)
 - Programming example [12-22](#)
 - Remote operation [12-20](#)
 - Sorting mode [12-7](#)
 - Types [12-2](#)
 - Limits 3, 5-12 (fine limits) [12-2](#)
 - Line power
 - Connection [1-9](#)
 - Frequency [1-11](#)
 - Linear staircase sweep [10-2](#)
 - LOCAL key [14-6](#)
 - Logarithmic staircase sweep [10-4](#)
 - Long-form and short-form versions [14-9](#)
- M**
- Manual ranging [7-2](#)
 - Math [8-4](#)
 - Built-in functions [8-4](#)
 - Front panel operation [8-6](#)
 - Remote operation [8-7](#)
 - User-defined functions [8-7](#)
 - Measure only
 - Remote operation [3-21](#)
 - Measure voltage or current [3-20](#)
 - memory sweep [18-93](#)
 - Menus [1-19](#)
 - Configuration [1-24](#)
 - Main [1-19](#)
 - Navigating [1-22](#)
 - Message
 - Program [14-10](#)
 - Response [14-12](#)
 - Status and error [B-2](#)

Message exchange protocol [14-13](#)
Multiple-element device binning [12-13](#)

N

NPLC caching [3-11](#)

O

Offset-compensated ohms (math function)
[8-4](#)

Ohms [4-9](#)

- 6-wire measurements [4-12](#)
- Auto measurements [4-4](#)
- Configuration menu [4-2](#)
- Enabling/disabling offset compensation [4-8](#)
- Guard [2-9](#), [6-28](#)
- Manual measurements [4-5](#)
- Measurement methods [4-3](#)
- Measurements [4-1](#)
- Offset-compensated [4-8](#)
- Programming example [4-14](#)
- Remote programming [4-13](#)
- Selecting measurement method [4-4](#)
- Sensing [4-6](#)
- Source readback [4-11](#)

Operating boundaries [6-10](#)

- Current compliance [6-20](#)
- Duty cycle [6-10](#)
- I-Source [6-15](#)
- Source or sink [6-10](#)
- Voltage compliance [6-17](#)
- V-Source [6-19](#)

Operation

- Considerations [3-10](#)
- Contact check function [F-3](#)
- Front panel GPIB [14-5](#)
- GPIB [14-4](#)
- Limit testing [12-4](#)
- Math [8-4](#)
- Overview [3-4](#)
- Pulse Mode [5-1](#)
- Remote vs. local [14-2](#)
- RS-232 interface [14-13](#)
- Sink [3-21](#)
- Sweep [10-1](#)

Options [1-3](#)

Output [13-6](#)

Output configuration

- Commands [13-12](#)
- Front panel operation [13-7](#)
- Programming example [13-12](#)

Remote operation [13-12](#)

Output Enable Line [13-6](#)

Output-off states [13-9](#)

Overheating

- Conditions [6-6](#)

- Protection [6-6](#)

Overview [1-5](#)

P

Percent deviation (math function) [8-6](#)

Power (math function) [8-4](#)

Power-up sequence [1-10](#)

Primary address [14-4](#)

Program messages [14-10](#)

Programming syntax [14-6](#)

Pulse energy limitations [5-9](#)

Pulse Mode

- Overview [5-2](#)

- Sweeps [10-24](#)

- Triggering [11-20](#)

Pulse mode

- characteristics [5-3](#)

- Fast pulse output [5-7](#)

- Output off-time [5-6](#)

- Pulse duty cycle [5-6](#)

- Pulse jitter [5-8](#)

- Pulse width [5-4](#)

Pulse Mode configuration

- Front panel operation [5-10](#)

- Remote operation [5-11](#)

PULSE SPEED (NPLC) - Model 2430 Pulse
Mode [7-8](#)

Pulse-measure considerations [5-12](#)

Pulse-measure programming example
[5-11](#)

Q

Query commands [14-9](#)

Queues [15-2](#), [15-18](#)

- Clearing [15-4](#)

- Error [15-19](#)

- Output [15-18](#)

R

Rack mount kits [1-4](#)

Range [7-2](#)

- Auto [7-3](#)

- Limitations [7-2](#)

- Manual [7-2](#)

Range and digits [7-2](#)

- Remote programming [7-5](#)

- Rear panel summary 1-7
 - Registers
 - Bit descriptions 15-11
 - Clearing 15-4
 - Condition 15-16
 - Event 15-16
 - Event enable 15-17
 - Measurement event 15-13
 - Operation event 15-12
 - Questionable event 15-15
 - Reading 15-6
 - Serial polling and SRQ 15-9
 - Service request enable 15-9
 - Standard event 15-11
 - Status byte 15-8
 - Relative 8-2
 - Front panel operation 8-2
 - Remote programming 8-3
 - Remote commands
 - Triggering 11-18
 - Remote operation 14-1
 - Auto zero 3-10
 - Compliance limit 3-8
 - Contact check function F-14
 - Data store 9-5
 - Digital output control 13-5
 - Guard selection 2-13
 - Limit testing 12-20
 - Measure only 3-21, 3-22
 - Operation enhancements 14-2
 - Pulse Mode configuration 5-11
 - Pulse Mode sweep 10-26
 - Selecting an interface 14-3
 - Sense selection 2-12
 - Source delay 3-14
 - Source-measure procedure 3-18
 - Sweep 10-19
 - Terminals selection 2-3
 - Triggering 11-10
 - V-source protection 3-12
 - Remote output configuration 13-12
 - Remote programming
 - Data store 9-5
 - Display 1-14
 - Filter 7-12
 - Math 8-7
 - Ohms 4-13
 - Range and digits 7-5
 - Relative 8-3
 - Speed 7-8
 - Sweeps 10-19
 - Response messages 14-12
 - RS-232 interface
 - Baud rate 14-14
 - Connections 14-15
 - Data bits and parity 14-14
 - Flow control (signal handshaking) 14-15
 - Operation 14-13
 - Sending and receiving data 14-13
 - Terminator 14-14
- S**
- Safety symbols and terms 1-2
 - scaling factor 18-95
 - SCPI
 - Command reference 18-1
 - Command summary 17-2
 - Eliminating common errors B-8
 - SCPI commands *see Command reference, Command summary, Common commands, and Signal-oriented measurement commands*
 - Sensing 2-5
 - 2-wire local 2-7
 - 4-wire remote 2-7
 - Guard 2-9, 6-32
 - Ohms 4-6
 - Selection 2-12
 - Serial polling 15-9
 - Settings
 - Default 1-15
 - Factory default 1-16
 - Power-on configuration 1-15
 - Remote setups 1-18
 - Restoring 1-15
 - Saving 1-15
 - Short-form rules 14-10
 - Signal-oriented measurement commands
 - :CONFIGure:<function> 17-2
 - :FETCh? 17-3
 - :MEASure[<function>]? 17-5
 - :READ? 17-4
 - [:SENSe[1]]:DATA[:LATest]? 17-4
 - Single-element device binning 12-13
 - Sink operation 3-22
 - Source delay 3-13
 - Source I measure I and source V measure V 6-22
 - Source memory sweep 10-6, 10-17, 10-22
 - Source-delay-measure cycle 6-7
 - Source-measure capabilities 3-4

- Source-measure procedure
 - Front panel operation [3-15](#)
 - Remote operation [3-18](#)
- Speed [7-7](#)
 - Remote programming [7-8](#)
 - Setting [7-7](#)
- Status and error messages [1-14](#)
- Status byte and service request (SRQ)
 - [15-2](#), [15-7](#)
- Status byte and service request commands
 - [15-10](#)
- Status register sets [15-2](#), [15-11](#)
- Store (data) [9-2](#)
- Sweep
 - Configuring and running [10-12](#)
 - Contact check function [F-6](#)
 - Customized [10-6](#), [10-16](#), [10-21](#)
 - Front panel operation [10-12](#)
 - Linear staircase [10-2](#), [10-19](#)
 - Logarithmic staircase [10-4](#), [10-19](#)
 - Programming example [10-19](#), [10-21](#), [10-23](#)
 - Pulse Mode (Model 2430 only) [10-24](#)
 - Remote operation [10-19](#)
 - Source memory [10-6](#), [10-17](#), [10-22](#)
 - Types [10-2](#)
- Sweep waveforms [6-9](#)
- System identification [1-10](#)

T

- TOGGLE key [1-13](#)
- Toggling the source and measure display fields [1-23](#)
- Trigger link [11-19](#)
 - Input requirements [11-19](#)
 - Output specifications [11-20](#)
- Triggering [11-1](#)
 - Examples [11-20](#)
 - External example [11-20](#)
 - Front panel configuration [11-7](#)
 - Front panel model [11-2](#)
 - Front panel operation [11-2](#)
 - Invalid Pulse Mode settings [11-24](#)
 - Pulse Mode (Model 2430) [11-20](#)
 - Remote commands [11-18](#)
 - Remote example [11-20](#)
 - Remote model [11-10](#)
 - Remote operation [11-10](#)

V

- Varistor alpha (math function) [8-5](#)

- Voltage (measure) [3-20](#)
- Voltage coefficient (math function) [8-5](#)
- V-Source operating boundaries [6-19](#)
- V-source protection [3-12](#)

W

- Warm-up [3-10](#)
- Waveforms
 - Sweep [6-9](#)

Specifications are subject to change without notice.
All Keithley trademarks and trade names are the property of Keithley Instruments, Inc.
All other trademarks and trade names are the property of their respective companies.

KEITHLEY

A G R E A T E R M E A S U R E O F C O N F I D E N C E

Keithley Instruments, Inc.

Corporate Headquarters • 28775 Aurora Road • Cleveland, Ohio 44139 • 440-248-0400 • Fax: 440-248-6168 • 1-888-KEITHLEY • www.keithley.com