

**MODEL 4300  
RF POWER METER  
INSTRUCTION MANUAL**

**BOONTON**

BOONTON ELECTRONICS CORPORATION

■ 25 EASTMANS ROAD

■ PARSIPPANY, NEW JERSEY 07054-0465

TELEPHONE: (973) 386-9696

■ FAX: (973) 386-9191

■ E-MAIL: [boonton@boonton.com](mailto:boonton@boonton.com)

---

MANUAL P/N 98401400B  
DATE 1/96

Printed in U.S.A.

# SAFETY SUMMARY

The following general safety precautions must be observed during all phases of operation and maintenance of this instrument. Failure to comply with these precautions or with specific warnings elsewhere in this manual violates safety standards of design, manufacture, and intended use of the instruments. Boonton Electronics Corporation assumes no liability for the customer's failure to comply with these requirements.

## THE INSTRUMENT MUST BE GROUNDED.

To minimize shock hazard the instrument chassis and cabinet must be connected to an electrical ground. The instrument is equipped with a three conductor, three prong AC power cable. The power cable must either be plugged into an approved three-contact electrical outlet or used with a three-contact to a two-contact adapter with the (green) grounding wire firmly connected to an electrical ground at the power outlet.

## DO NOT OPERATE THE INSTRUMENT IN AN EXPLOSIVE ATMOSPHERE.

Do not operate the instrument in the presence of flammable gases or fumes.

## KEEP AWAY FROM LIVE CIRCUITS.

Operating personnel must not remove instrument covers. Component replacement and internal adjustments must be made by qualified maintenance personnel. Do not replace components with the power cable connected. Under certain conditions dangerous voltages may exist even though the power cable was removed; therefore, always disconnect power and discharge circuits before touching them.

## DO NOT SERVICE OR ADJUST ALONE.

Do not attempt internal service or adjustment unless another person, capable of rendering first aid and resuscitation, is present.

## DO NOT SUBSTITUTE PARTS OR MODIFY INSTRUMENT.

Do not install substitute parts or perform any unauthorized modification of the instrument. Return the instrument to Boonton Electronics for repair to ensure that the safety features are maintained.

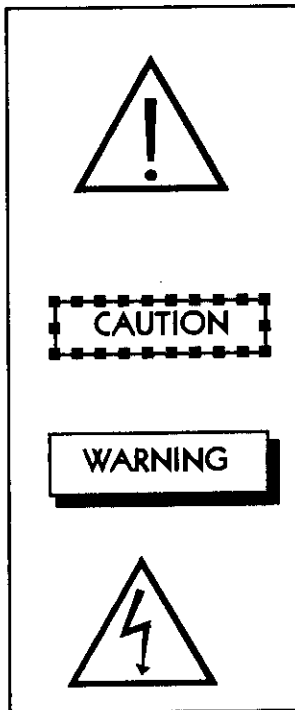

This safety requirement symbol has been adopted by the International Electrotechnical Commission, Document 66 (Central Office) 3, Paragraph 5.3, which directs that an instrument be so labeled if, for the correct use of the instrument, it is necessary to refer to the instruction manual. In this case it is recommended that reference be made to the instruction manual when connecting the instrument to the proper power source. Verify that the correct fuse is installed for the power available, and that the switch on the rear panel is set to the applicable operating voltage.

The CAUTION sign denotes a hazard. It calls attention to an operation procedure, practice, or the like, which, if not correctly performed or adhered to, could result in damage to or destruction of part or all of the equipment. Do not proceed beyond a CAUTION sign until the indicated conditions are fully understood and met.

The WARNING sign denotes a hazard. It calls attention to an operation procedure, practice, or the like, which, if not correctly performed or adhered to, could result in injury or loss of life. Do not proceed beyond a warning sign until the indicated conditions are fully understood and met.

This SAFETY REQUIREMENT symbol has been adopted by the International Electrotechnical Commission, document 66 (Central Office)3, Paragraph 5.3 which indicates hazardous voltage may be present in the vicinity of the marking.

# TABLE OF CONTENTS

| <b>Section 1 General Information</b> |                                                | <b>Page</b> |
|--------------------------------------|------------------------------------------------|-------------|
| <b>Paragraph</b>                     |                                                |             |
| 1-1                                  | Introduction                                   | 1-1         |
| 1-2                                  | Description                                    | 1-1         |
| 1-3                                  | Configuration                                  | 1-3         |
| 1-4                                  | Accessories                                    | 1-3         |
| 1-5                                  | Sensors                                        | 1-4         |
| 1-6                                  | Options                                        | 1-4         |
| 1-7                                  | Specifications                                 | 1-4         |
| <b>Section 2 Installation</b>        |                                                |             |
| 2-1                                  | Introduction                                   | 2-1         |
| 2-2                                  | Unpacking                                      | 2-1         |
| 2-3                                  | Mounting                                       | 2-1         |
| 2-4                                  | Calibrator and Input Channel Installation      | 2-2         |
| 2-5                                  | Power Requirements                             | 2-2         |
| 2-6                                  | Cable Connections                              | 2-2         |
| 2-7                                  | Preliminary Checkout                           | 2-2         |
| <b>Section 3 Operation</b>           |                                                |             |
| 3-1                                  | Introduction                                   | 3-1         |
| 3-2                                  | Operating Controls, Indicators, and Connectors | 3-1         |
| 3-3                                  | Operating Instructions                         | 3-1         |
| 3-4                                  | Initializing                                   | 3-1         |
| 3-5                                  | Local Operation                                | 3-3         |
| 3-6                                  | Single Channel Operation                       | 3-3         |
| 3-7                                  | Multichannel Operation                         | 3-5         |
| 3-8                                  | Summation Operation                            | 3-6         |
| 3-9                                  | 75 Ohm Sensor Calibration                      | 3-6         |
| 3-10                                 | Correction Factor Entry (75 Ohm Sensors)       | 3-6         |
| 3-11                                 | Specific Key Operation                         | 3-7         |
| 3-12                                 | ESCAPE Key                                     | 3-7         |
| 3-13                                 | SHIFT Key                                      | 3-7         |
| 3-14                                 | 0 through 9 Keys                               | 3-7         |
| 3-15                                 | =, -, and • Keys                               | 3-7         |
| 3-16                                 | (BACKSPACE) Key                                | 3-7         |
| 3-17                                 | ENTER Key                                      | 3-7         |
| 3-18                                 | SCROLL Key                                     | 3-7         |
| 3-19                                 | (LOCAL) Key                                    | 3-7         |
| 3-20                                 | SRQ Key                                        | 3-7         |
| 3-21                                 | ADDR Key                                       | 3-7         |
| 3-22                                 | ZERO Key                                       | 3-7         |
| 3-23                                 | TEST Key                                       | 3-7         |
| 3-24                                 | SPCL Key                                       | 3-8         |
| 3-25                                 | FILTER Key                                     | 3-8         |
| 3-26                                 | FREQ Key                                       | 3-10        |
| 3-27                                 | dB CF Key                                      | 3-10        |
| 3-28                                 | DTY CY Key                                     | 3-10        |

**Section 3 (Cont.)**

|       |                                  |      |
|-------|----------------------------------|------|
| 3-29  | DSBL Key                         | 3-10 |
| 3-30  | LO LIM Key                       | 3-10 |
| 3-31  | HI LIM Key                       | 3-10 |
| 3-32  | PK HLD Key                       | 3-11 |
| 3-33  | PK OFF Key                       | 3-11 |
| 3-34  | CHAN $\Sigma$ Key                | 3-11 |
| 3-35  | $\Sigma$ ENA Key                 | 3-11 |
| 3-36  | SET CH Key                       | 3-11 |
| 3-37  | CHAN Key                         | 3-11 |
| 3-38  | MULTI Key                        | 3-11 |
| 3-39  | SENSOR DATA VIEW Key             | 3-11 |
| 3-40  | SENSOR DATA ENTRY Key            | 3-11 |
| 3-41  | SENSOR S/N Key                   | 3-13 |
| 3-43  | SENSOR ASSIGN Key                | 3-13 |
| 3-44  | dB REF SET Key                   | 3-13 |
| 3-45  | dB REF LOAD Key                  | 3-14 |
| 3-46  | dBr Key                          | 3-14 |
| 3-47  | dBm Key                          | 3-14 |
| 3-48  | WATTS Key                        | 3-14 |
| 3-49  | CALIBRATOR LIMIT Key             | 3-14 |
| 3-50  | CALIBRATOR ON/OFF Key            | 3-14 |
| 3-51  | CALIBRATOR AUTO CAL Key          | 3-14 |
| 3-52  | AUTO CAL                         | 3-14 |
| 3-53  | FIXED CAL                        | 3-15 |
| 3-54  | CALIBRATOR LEVEL Key             | 3-15 |
| 3-55  | RANGE SET Key                    | 3-15 |
| 3-56  | RANGE HOLD Key                   | 3-15 |
| 3-57  | RANGE AUTO Key                   | 3-15 |
| 3-58  | INSTR STORE Key                  | 3-15 |
| 3-59  | INSTR RECALL Key                 | 3-15 |
| 3-60  | RECALL 0 CONDITIONS              | 3-15 |
| 3-61  | SRQ Key                          | 3-16 |
| 3-100 | Remote (GPIB) Operation          | 3-16 |
| 3-101 | Introduction                     | 3-16 |
| 3-103 | Local Operation                  | 3-16 |
| 3-104 | Remote Operation                 | 3-16 |
| 3-105 | Setting the Bus Address          | 3-16 |
| 3-106 | Terminating Characters           | 3-16 |
| 3-107 | Bit Switch Setting (Rear Panel). | 3-16 |
| 3-108 | Listen Operation                 | 3-16 |
| 3-109 | Talk Operation                   | 3-16 |
| 3-111 | IEEE-488 Commands Supported      | 3-17 |
| 3-112 | Number Formatting                | 3-19 |
| 3-113 | Message Format                   | 3-19 |
| 3-114 | Listen Parameter Commands        | 3-19 |
| 3-116 | Listen Action Commands           | 3-19 |
| 3-117 | Listen Array Commands            | 3-19 |
| 3-118 | Talk Array Commands              | 3-19 |
| 3-119 | Talk Modes                       | 3-20 |
| 3-120 | Talk Mode 0                      | 3-20 |
| 3-121 | Talk Mode 1                      | 3-20 |

### **Section 3 (Cont.)**

|       |                            |      |
|-------|----------------------------|------|
| 3-122 | Talk Mode 2                | 3-21 |
| 3-123 | Talk Mode 3                | 3-21 |
| 3-124 | Talk Mode 4                | 3-21 |
| 3-125 | Talk Mode 5                | 3-22 |
| 3-126 | Talk Mode 6                | 3-22 |
| 3-127 | Talk Mode 7                | 3-23 |
| 3-128 | Talk Mode 8                | 3-23 |
| 3-129 | IEEE-488 Bus Only Commands | 3-23 |
| 3-130 | Talk Mode                  | 3-23 |
| 3-131 | DATAIN                     | 3-23 |
| 3-132 | DATAOUT                    | 3-24 |
| 3-133 | FREQIN                     | 3-24 |
| 3-134 | FREQOUT                    | 3-24 |
| 3-135 | DCIN                       | 3-25 |
| 3-136 | DCOUT                      | 3-25 |
| 3-137 | DSOFF                      | 3-25 |
| 3-138 | DSON                       | 3-25 |
| 3-139 | TEACH                      | 3-25 |
| 3-140 | LEARN                      | 3-26 |
| 3-141 | MESSAGE                    | 3-26 |
| 3-142 | SRQMASK                    | 3-26 |
| 3-143 | CHANSUM                    | 3-26 |
| 3-144 | GPIB Programming Examples  | 3-27 |
| 3-145 | Error Messages             | 3-27 |

### **Section 4 Making Measurements**

|      |                                         |      |
|------|-----------------------------------------|------|
| 4-1  | Introduction                            | 4-1  |
| 4-2  | Sensor Calibration                      | 4-1  |
| 4-3  | Zeroing                                 | 4-3  |
| 4-4  | Filtering and Noise                     | 4-8  |
| 4-5  | Measurement Time                        | 4-12 |
| 4-6  | High Frequency Accuracy                 | 4-13 |
| 4-7  | Pulsed RF Operation                     | 4-15 |
| 4-8  | Chart Recorder Operation                | 4-15 |
| 4-9  | Triggered Operation and Settled Reading | 4-20 |
| 4-10 | Waveform Sensitivity                    | 4-21 |

### **Section 5 Theory**

|     |                   |     |
|-----|-------------------|-----|
| 5-1 | Introduction      | 5-1 |
| 5-2 | Sensors           | 5-2 |
| 5-3 | Input Channels    | 5-2 |
| 5-4 | Control Board     | 5-4 |
| 5-5 | 30 MHz Calibrator | 5-5 |
| 5-6 | 50 MHz Calibrator | 5-7 |

### **Section 6 Maintenance**

|     |                         |     |
|-----|-------------------------|-----|
| 6-1 | Introduction            | 6-1 |
| 6-2 | Safety Requirements     | 6-1 |
| 6-3 | Test Equipment Required | 6-1 |
| 6-4 | Cleaning Procedure      | 6-1 |
| 6-5 | Removal and Replacement | 6-1 |
| 6-6 | Inspection              | 6-1 |
| 6-7 | Battery Replacement     | 6-1 |
| 6-8 | 400 Hz Operation        | 6-2 |

**Section 6-100 Performance Tests**

|       |                                     |       |
|-------|-------------------------------------|-------|
| 6-101 | Introduction                        | 6-101 |
| 6-102 | Power Supply Test                   | 6-101 |
| 6-103 | Battery Test                        | 6-101 |
| 6-104 | Display Test                        | 6-101 |
| 6-105 | Key Test                            | 6-101 |
| 6-106 | Memory Test                         | 6-102 |
| 6-107 | Bit Switch Test                     | 6-102 |
| 6-108 | ROM Test                            | 6-102 |
| 6-109 | Bus Test                            | 6-102 |
| 6-110 | Chopper Offset Test                 | 6-103 |
| 6-111 | Reference Frequency Accuracy Test   | 6-103 |
| 6-112 | DC Calibration Test                 | 6-104 |
| 6-113 | Autocalibration Test (AUTO CAL)     | 6-105 |
| 6-114 | 30 MHz Calibrator Performance Tests | 6-105 |
| 6-115 | 50 MHz Calibrator Performance Test  | 6-106 |
| 6-116 | Chart Recorder Verification Test    | 6-106 |

**Section 6-200 Adjustments**

|       |                                       |       |
|-------|---------------------------------------|-------|
| 6-201 | Introduction                          | 6-201 |
| 6-202 | Power-Up Reset Adjustment             | 6-201 |
| 6-203 | Initializing Via Bit Switches         | 6-201 |
| 6-204 | Input Channel Adjustments             | 6-201 |
| 6-205 | 30 MHz Calibrator Adjustments         | 6-206 |
| 6-206 | Method 1, (Variable Reference Method) | 6-206 |
| 6-207 | Method 2, Fixed Attenuator Method     | 6-209 |
| 6-208 | 50 MHz Calibrator Adjustment          | 6-211 |
| 6-209 | DC Cal Factor Entry and Edit          | 6-211 |
| 6-210 | Sensor Data Entry                     | 6-211 |
| 6-211 | Autocalibration                       | 6-212 |
| 6-212 | AC Reference Frequency Calibration    | 6-212 |

**Section 6-300 Troubleshooting**

|       |                                             |       |
|-------|---------------------------------------------|-------|
| 6-301 | Access to Boards                            | 6-301 |
| 6-302 | General                                     | 6-301 |
| 6-303 | Test 100 (Power Supply)                     | 6-301 |
| 6-304 | Test 101 (Power-Up/Reset)                   | 6-301 |
| 6-305 | Test 102 (Clocks)                           | 6-301 |
| 6-306 | Test 103 (LED Backlight)                    | 6-305 |
| 6-307 | Test 104 ( $\mu$ P Quick Check)             | 6-305 |
| 6-308 | Test 105 (Display Circuits)                 | 6-305 |
| 6-309 | Test 106 (Microprocessor Debug)             | 6-305 |
| 6-310 | Test 107 (Non-Volatile RAM)                 | 6-305 |
| 6-311 | Test 108 (Keyboard Circuits)                | 6-306 |
| 6-312 | Test 109 (GPIB/IEEE-488 Bus)                | 3-306 |
| 6-313 | Test 110 Chopper Clocks, Phase-Locked-Loop) | 6-306 |
| 6-314 | Test 111 (Internal Bus)                     | 6-306 |
| 6-315 | Test 112 (Channel Swapping)                 | 6-306 |
| 6-316 | Test 113 (Empty Frame Check)                | 6-307 |
| 6-317 | Test 200 (Channel Troubleshooting)          | 6-307 |

**6-300 Troubleshooting (Cont.)**

|       |                                              |       |
|-------|----------------------------------------------|-------|
| 6-318 | Test 201 (Z80, RAM, ROM Test)                | 6-307 |
| 6-319 | Test 202 (Z80)                               | 6-307 |
| 6-320 | Test 203 (Decoder Test)                      | 6-307 |
| 6-321 | Test 204 (+5 VDC Reference)                  | 6-307 |
| 6-322 | Test 205 (Recorder DAC Test)                 | 6-307 |
| 6-323 | Test 206 (A/D Test 1)                        | 6-308 |
| 6-324 | Test 207 (A/D Test 2)                        | 6-308 |
| 6-325 | Test 208 (Control Board Communication)       | 6-308 |
| 6-326 | Test 209 (Bus Check)                         | 6-308 |
| 6-327 | Test 210 (OP Amps and Ranging)               | 6-308 |
| 6-328 | Test 211 (Dynamic Filter Check)              | 6-309 |
| 6-329 | Test 212 (Chopper Drive Test)                | 6-309 |
| 6-330 | Test 213 (Chopper Coarse Adjust)             | 6-309 |
| 6-331 | Test 214 (LATCH)                             | 6-309 |
| 6-332 | Test 215 (Amplifier Midpoint, TP2)           | 6-309 |
| 6-333 | Test 216 (Filter Coarse Check)               | 6-309 |
| 6-334 | Test 217 (TP1-Amplifier Debug)               | 6-310 |
| 6-335 | Test 218 (AR6-B Circuits)                    | 6-310 |
| 6-336 | Test 219 (AR1, 2, 6 Circuits)                | 6-310 |
| 6-337 | Test 220 (Chopper)                           | 6-310 |
| 6-338 | Test 221 (Analog Switches)                   | 6-310 |
| 6-339 | 30 MHz Troubleshooting                       | 6-310 |
| 6-340 | Test 400 (General Bus Operation)             | 6-311 |
| 6-341 | Test 401 (Bus Errors)                        | 6-311 |
| 6-342 | Test 402 (Relay Drive)                       | 6-311 |
| 6-343 | Test 403 (DAC Check)                         | 6-311 |
| 6-344 | Test 404 (30 MHz Digital Board)              | 6-311 |
| 6-345 | Test 405 (Isolation of Generator Sections)   | 6-312 |
| 6-346 | Test 406 (Oscillator)                        | 6-312 |
| 6-347 | Test (Amplifier Q5)                          | 6-312 |
| 6-348 | Test 408 (Control Loop)                      | 6-312 |
| 6-349 | Test 409 (Attenuator)                        | 6-312 |
| 6-350 | Test 410 (Conclusion)                        | 6-313 |
| 6-351 | Test 300 (50 MHz Calibrator Troubleshooting) | 6-313 |

**Section 7 Parts List**

|                  |     |
|------------------|-----|
| 7-1 Introduction | 7-1 |
|------------------|-----|

**Section 8 Schematic Diagrams**

|                   |         |
|-------------------|---------|
| Table of Contents | 8-1/8-2 |
|-------------------|---------|

**Warranty**

## LIST OF TABLES

| <b>Table</b> |                                                 | <b>Page</b> |
|--------------|-------------------------------------------------|-------------|
| 1-1          | Specifications                                  | 1-5         |
| 3-1          | Operating Controls, Indicators and Connectors   | 3-1         |
| 3-2          | Channel Parameters                              | 3-3         |
| 3-3          | Additional Operations                           | 3-3         |
| 3-4          | Theory of Use and Application                   | 3-4         |
| 3-5          | Special Functions                               | 3-8         |
| 3-6          | 4200/4300 Sensor Cross Referencing              | 3-12        |
| 3-7          | Listen Parameter Commands                       | 3-17        |
| 3-8          | Listen Action Commands                          | 3-18        |
| 3-9          | Listen Array Commands                           | 3-19        |
| 3-10         | Talk Array Commands                             | 3-20        |
| 3-11         | Talk Modes                                      | 3-20        |
| 3-12         | SRQ Mask                                        | 3-26        |
| 3-13         | Error Messages                                  | 3-28        |
| 4-1          | Default Filters                                 | 4-8         |
| 4-2          | 4300 Settling Time to 1%                        | 4-13        |
| 4-3          | Chart Recorder Operation                        | 4-15        |
| 5-1          | Input Channel Gain Values                       | 5-3         |
| 6-101        | Maintenance Test Equipment                      | 6-4         |
| 6-102        | Key Test Key Codes                              | 6-101       |
| 6-103        | Reference Frequency Accuracy, Coaxial Sensors   | 6-104       |
| 6-104        | Reference Frequency Accuracy, Waveguide Sensors | 6-104       |
| 6-105        | DC Count Tolerance                              | 6-105       |
| 6-106        | 30 MHz Tolerances                               | 6-106       |
| 6-201        | Initialization                                  | 6-201       |
| 6-202        | Bit Switch Functions                            | 6-203       |
| 6-203        | DC Calibration Tolerance                        | 6-205       |
| 6-204        | DC Verification Tolerance                       | 6-205       |
| 6-205        | Normal Channel Bit Switch Settings              | 6-206       |
| 6-206        | Waveguide Sensor Reference Frequencies          | 6-213       |
| 6-207        | Upscale and Downscale Calibration Points        | 6-213       |
| 6-301        | Input Channel Voltages                          | 6-308       |
| 6-302        | 30 MH Calibrator Attenuators                    | 6-311       |
| 6-303        | 30 MHz Calibrator Control Voltage               | 6-311       |
| 6-304        | 30 MHz Calibrator RF Voltages                   | 6-312       |



## LIST OF FIGURES

| <b>Figures</b> |                                                    | <b>Page</b> |
|----------------|----------------------------------------------------|-------------|
| 1-1            | Outline Dimensions                                 | 1-1         |
| 2-1            | Packing and Unpacking Diagram                      | 2-1         |
| 2-2            | Input Module Installation                          | 2-3/2-4     |
| 2-3            | 30 MHz Calibrator Installation (Front)             | 2-5/2-6     |
| 2-4            | 30 MHz Calibrator Installation (Rear)              | 2-7/2-8     |
| 2-5            | 50 MHz Calibrator Installation                     | 2-9/2-10    |
| 3-1            | 4300 Front Panel                                   | 3-2         |
| 3-2            | Rear Panel                                         | 3-2         |
| 3-3            | Front Panel Keys                                   | 3-2         |
| 3-4            | Single Channel Display                             | 3-4         |
| 3-5            | Multichannel Display                               | 3-5         |
| 3-6            | Summation Display                                  | 3-6         |
| 4-1            | 14-Point Sensor Calibration                        | 4-1         |
| 4-2            | Autocalibration of Sensor                          | 4-2         |
| 4-3            | Typical High Frequency Sensor Calibration          | 4-3         |
| 4-4            | Diode Sensor Decay                                 | 4-4         |
| 4-5            | Thermal Sensor Decay                               | 4-4         |
| 4-6            | Extended Hold Range Mode                           | 4-5         |
| 4-7            | Noise Reduction for Universal Channels             | 4-6         |
| 4-8            | Noise Reduction for Thermal Channels               | 4-7         |
| 4-9            | Typical Error Band Specification                   | 4-9         |
| 4-10           | Probability of Falling Within an Error Band        | 4-9         |
| 4-11           | 51013 Sensor With 2.8 Second Filter                | 4-10        |
| 4-12           | 51013 Sensor With 10 Second Filter                 | 4-11        |
| 4-13           | Integration of Power                               | 4-12        |
| 4-14           | Mismatch Uncertainties Chart                       | 4-14        |
| 4-15           | Pulsed RF Accuracy for 51016 Sensor                | 4-16        |
| 4-16           | Pulsed RF Accuracy for 51017 Sensor                | 4-17        |
| 4-17           | Pulsed RF Accuracy for 51013 Diode Sensor          | 4-18        |
| 4-18           | Error Due to AM Modulation (Diode Sensor 51013)    | 4-22        |
| 5-1            | Overall Block Diagram                              | 5-1         |
| 5-2            | Input Board Block Diagram                          | 5-2         |
| 5-3            | Control Board Block Diagram                        | 5-4         |
| 5-4            | 30 MHz Generator Block Diagram                     | 5-6         |
| 5-5            | 30 MHz Digital Block Diagram                       | 5-6         |
| 5-6            | 50 MHz Calibrator Block Diagram                    | 5-7         |
| 6-101          | Bus Test Display                                   | 6-102       |
| 6-201          | 4300 Bit Switch Diagram                            | 6-202       |
| 6-202          | Calibration at 30 MHz Below 0 dBm                  | 6-206       |
| 6-203          | 30 MHz Calibration Above 10 dBm                    | 6-208       |
| 6-204          | Zeroing the EPM-1                                  | 6-208       |
| 6-205          | 0 dBm Measurement                                  | 6-208       |
| 6-206          | Attenuated Measurements                            | 6-208       |
| 6-207          | Measurement at -60 dBm                             | 6-209       |
| 6-208          | Wraparound Measurement                             | 6-209       |
| 6-209          | Basic Reference Frequency Calibration              | 6-212       |
| 6-210          | High Level Reference Frequency Calibration, Step 1 | 6-214       |
| 6-211          | High Level Reference Frequency Calibration, Step 2 | 6-214       |
| 6-301          | Overall Troubleshooting                            | 6-302       |
| 6-302          | Input Channel Troubleshooting                      | 6-303       |
| 6-303          | 30 MHz Calibrator Troubleshooting                  | 6-304       |

**List of Figures (Cont.)**

|      |                                        |           |
|------|----------------------------------------|-----------|
| 8-1  | Frame Schematic Sheet 1 of 2           | 8-3/8-4   |
| 8-2  | Frame Schematic Sheet 2 of 2           | 8-5       |
| 8-3  | Chopper II Component Location          | 8-6       |
| 8-4  | Chopper II Schematic                   | 8-7       |
| 8-5  | Input Component Location, Sheet 1 of 2 | 8-8       |
| 8-6  | Input Schematic, Sheet 1 of 2          | 8-9       |
| 8-7  | Input Component Location               | 8-10      |
| 8-8  | Input Schematic, Sheet 2 of 2          | 8-11      |
| 8-9  | 30 MHz Oscillator Component Location   | 8-12      |
| 8-10 | 30 MHz Oscillator Schematic            | 8-13      |
| 8-11 | 30 MHz Digital Component Location      | 8-14      |
| 8-12 | 30 MHz Digital Schematic               | 8-15      |
| 8-13 | 50 MHz Calibrator Component Location   | 8-16      |
| 8-14 | 50 MHz Calibrator Schematic            | 8-17/8-18 |
| 8-15 | Keyboard Schematic                     | 8-19      |
| 8-16 | Bus Component Location                 | 8-20      |
| 8-17 | Bus Schematic                          | 8-21      |
| 8-18 | Control Component Location             | 8-22      |
| 8-19 | Control Schematic, Sheet 1 of 3        | 8-23      |
| 8-20 | Control Component Location             | 8-24      |
| 8-21 | Control Schematic, Sheet 2 of 3        | 8-25      |
| 8-22 | Control Component Location             | 8-26      |
| 8-23 | Control Schematic, Sheet 3 of 3        | 8-27/8-28 |

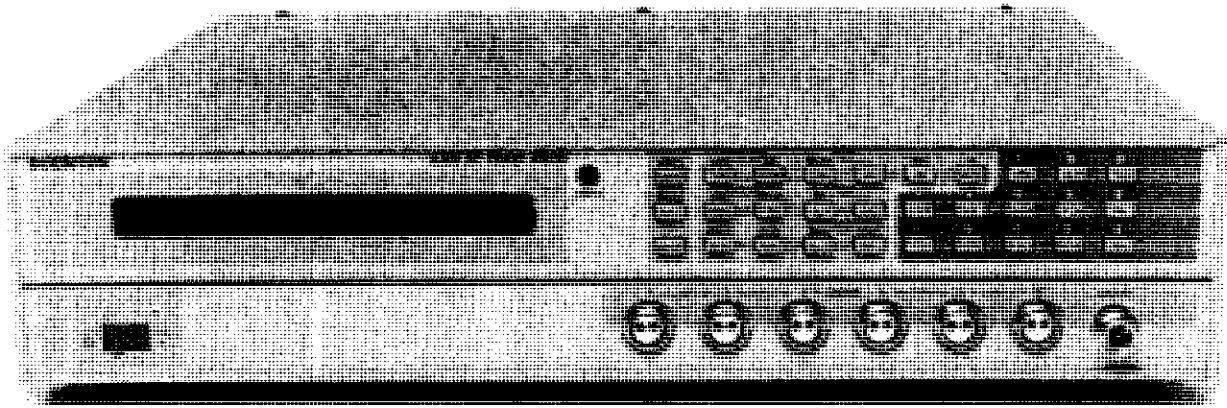

Model 4300 RF Powermeter

# SECTION 1

## GENERAL INFORMATION

### 1-1. INTRODUCTION.

This instruction manual provides general information, installation and operating instructions, applications, theory of operation, maintenance instructions, parts list, and schematics for the Model 4300 RF Powermeter. Refer to Figure 1-1.

### 1-2. DESCRIPTION.

The Model 4300 is a microprocessor-based solid state RF power meter. The instrument is capable of measuring 6 simultaneous RF power levels from 0.1 nW (-70 dBm) to 2W (+33 dBm) over a frequency range of 100 kHz to 110 GHz.

The Model 4300 design features are as follows:

1. **Multiple real time measurements.** Up to six field-installable input channel modules range select, measure, and process sensor data independently using their own dedicated input amplifiers, A to D converters, and microprocessors. Channel data is then collected by the 4300's 16-bit host microprocessor, and presented to the user via the front panel

display or a high-speed GPIB port on the rear of the instrument. Data processing for each channel includes offset nulling, sensor linearity and frequency correction, autoranging, adjustable filtering, signal limit checking, conversion to watts or dBm, and sum/difference operations between two or more

2. **Input Channel Modules.** The instrument can operate with one to six modules. Two Input Channel Modules are available. The 4311 Universal Channel Module may be used with all the Boonton diode and thermal sensors. The 4312 Thermocouple Channel Module operates with Boonton thermal sensors only. Since it is optimized for thermocouple heads, the 4312 is 5 dB lower in noise than the 4311. The Input Channel Modules are field installable.

3. **Sensors.** The instrument's power and frequency ranges are determined by the sensors used with the instrument. The 4300 series sensors cover a power range of -60 dBm to +33 dBm (-70 dBm with long digital filtering and limited accuracy) from 100 kHz to 110 GHz, and are fully compatible with the Boonton Model 4200. Two types are available—diode and thermal sensors.

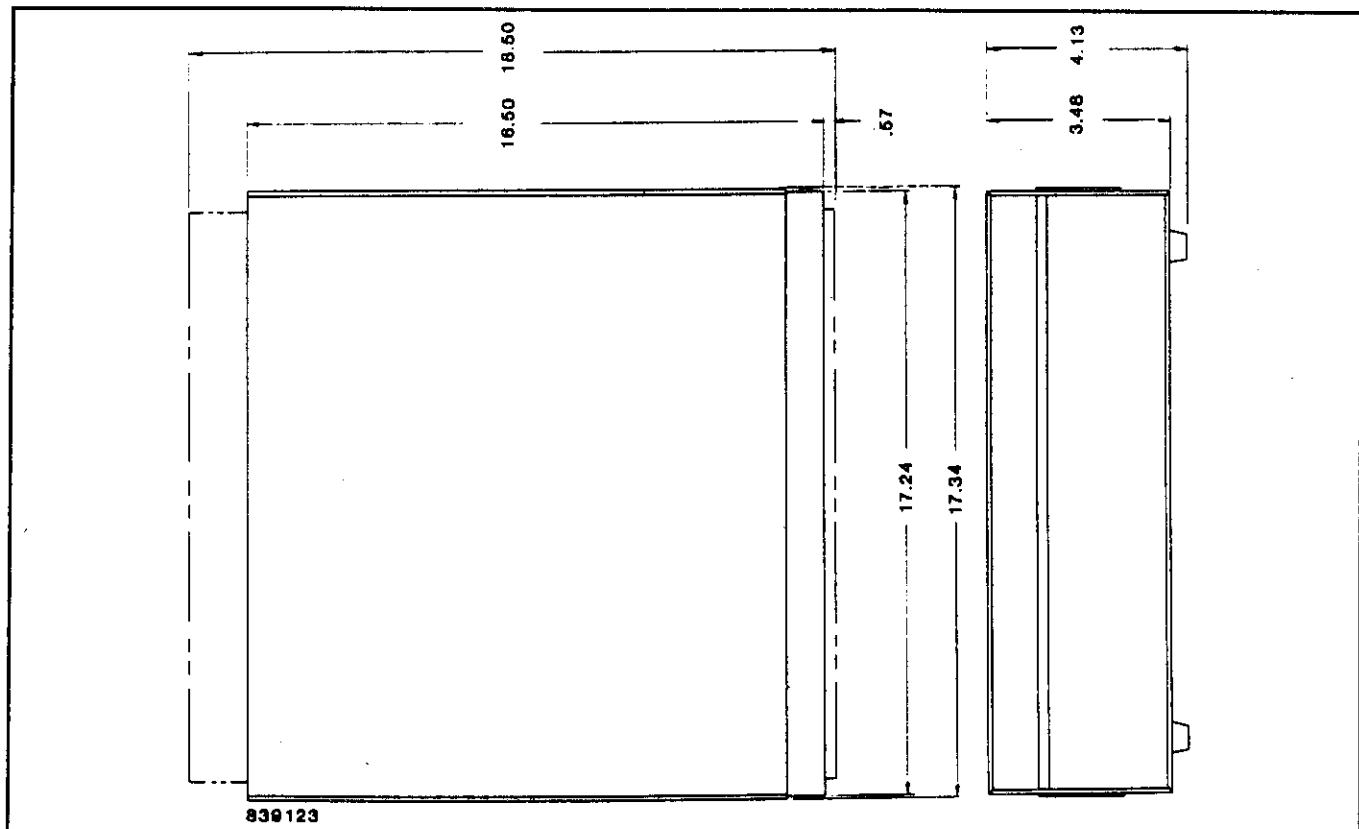

Figure 1-1. Outline Dimensions

Section 1  
General Information

4. **Diode Sensors.** Diode sensors measure the voltage across a precision resistor using specially selected RF detector diodes. The detection is square-law (true RMS) over the bottom two thirds of their range (roughly) and peak detecting at the top; however, the instrument is calibrated for sinewaves over the entire region. Therefore, measurements at the top are valid only for non-modulated signals. In the RMS region, the linearity error is extremely good and any signal type can be measured.

The diode response has been extended into the peak detecting region with the use of real time shaping for the diode curve, which, when used with the 30 MHz programmable calibrator, gives shaping errors less than .01 dB. When coupled with the high sensitivity of the diodes, this method allows an unprecedented 80 dB or more of dynamic range per sensor. Diode sensors are rugged and have greater than 5 dB overload headroom on the top for continuous signals. If desired, the RMS responding region can be extended to higher power levels by using an external attenuator.

5. **Thermal Sensors.** Thermal sensors measure the voltage developed across a dissimilar metal junction (thermocouple) caused by the thermal gradient that the RF power generates. Since they are heat detecting, they are true RMS responding over the entire range. They can also handle very high peak powers (15-30 watts) for very short duty cycles and still give valid results. The dynamic range is 40 dB (50 dB with long filtering and degraded accuracy) and they are not as sensitive as diode sensors.

6. **Calibration.** Calibration data for 20 sensors can be stored in non-volatile RAM. Linearity and high frequency correction sensor calibration data can be entered. The linearity data is supplied with each sensor and is entered when the sensor is purchased. Where maximum accuracy is required, an optional 30 MHz variable-output calibrator may be installed in the Model 4300 which automatically generates and stores sensor linearity calibration data by stepping the sensor through a series of calibrated power levels. Sensor high frequency calibration data for the entire operating frequency range is supplied with the sensor and can be stored in memory. When the frequency is entered, the instrument looks up the appropriate cal factor data and interpolates as necessary. High frequency data for 35 points can be stored for 14 of the 20 sensors and 80 points for the remaining 6. Sensors can be assigned to any of the 6 channels without reloading the data. Sensor data can also be uploaded and downloaded over the bus.

7. **LCD 80 Display.** A two-line by 40 character alphanumeric display is provided which displays power for up to six channels simultaneously, or in Single Channel mode, displays extended parameter information such as the range, filter length, frequency, etc. Full menu prompting is

provided in the Sensor Entry modes and Special modes such as triggering setup, chart recorder scaling and diagnostics. Power measurements may be displayed in dBm, watts, dB or ratio (percent).

8. **30 MHz Calibrator.** The 4321 30 MHz Programmable Calibrator Module provides a precision 30 MHz power reference signal between -60 dBm and +20 dBm in 1 dB steps. The output is controlled from the 4300 front panel or through the GPIB interface, and may be operated manually to generate a fixed reference power level, or automatically, to calculate and store sensor linearity data throughout the operating range of the sensor. The 4321 has an NIST traceable accuracy of 0.05 dB. Each unit is calibrated using attenuation references which are traceable back to the 30 MHz piston attenuator, an NIST traceable standard that is accurate to .003 dB/10 dB. The 4321 is available with either front or rear panel type N output connectors, and is for use with coaxial sensors only.

9. **50 MHz Calibrator.** The 4323 Power Reference Module provides a fixed 50 MHz 0 dBm signal for applications requiring 50 MHz traceability at 0 dBm. The 4323 is used when the increased accuracy of 4321 30 MHz Programmable Calibrator Module is not necessary. The unit can be installed with a front or rear panel output and may also be installed concurrently with the 4321, (one front and one rear).

10. **Selectable Filtering.** Each measurement channel of the 4300 provides a programmable digital filter for the reduction of measurement noise, both source and sensor generated. This filter calculates the unweighted, running average of the last  $n$  samples, where  $n$  may range from 1 to 1000, which corresponds to a filter time of 0.02 to 20 seconds. The filter time may be programmed by the user, or selected automatically by the 4300. In Automatic mode, default filter values are chosen based upon the channel's input signal level in order to optimize the tradeoff between noise and settling time. When the 4300 is operating in triggered mode, the filter pipeline is cleared of all previous data points and averaging begins whenever a new trigger signal is received. Measurement data is available immediately, but the filter will not be fully effective (readings may be noisy) until its pipeline fills with data points.

11. **Settled Reading.** The 4300 can be set to hold off display and bus updates until the readings are settled to within 1% (0.04 dB).

12. **Channel Summation Mode.** Up to 6 channels can be added/subtracted (in dB) or multiplied/divided (in watts) for ratio measurements.

13. **Chart Recorder Output.** A 0 to 10 DC output is provided for each input channel which can be scaled to any

full scale reference power (linear Mode). Additionally, in dB mode the output is proportional to dB with selectable scaling by choosing two endpoints. For example: a 1dB window can be assigned to span the full 0 to 10 V output range. The scaling on each channel is independent. Alternatively, the outputs can be selected to represent an out-of-limits condition or the zeroing operation (TTL level). Also, one of the outputs can be programmed to represent the difference/ratio of 2 to 6 channels.

**14. Diagnostics.** A full complement of keyboard or bus activated internal diagnostics are provided. Tests include memory checks, keyboard and display checks, and when the 30 MHz calibrator is installed, a complete measurement chain check.

**15. GPIB.** A high-speed GPIB interface (IEEE-488) is standard. This port may be used to operate the Model 4300 remotely and collect measurement data. The 4300 is typically able to perform 40 measurements per second over the GPIB. In Multichannel mode, this allows a full six channel measurement to be made in less than 150 milliseconds.

**16. MATE.** Optional. Consult factory if MATE operation is required.

**17. Zeroing.** Automatic zeroing (nulling of offsets from the sensor and input channels) is done independently on each range. Zeroing time is from 8 to 20 seconds depending on the digital filter selected.

**18. Setup Registers.** Nine panel setup states can be stored in the nonvolatile memory. In addition, learn strings can be downloaded from the bus to set up the instrument and load sensor data.

**19. Pulse Power.** Although the Model 4300 is an average responding power meter, for rectangular waveforms the duty cycle can be entered and the instrument will calculate the pulse (peak) power. This is valid in the RMS regions of the diode sensors and over the full operating range of the thermal sensors. For the diode sensors, the RMS region is extended slightly with the use of internal correction curves.

**20. Non Volatile Memory.** The 4300 employs a battery as backup power for the nonvolatile memory on the main control board and each channel board assembly. The battery is used to retain calibration data and setup information during times when AC power is not present. A primary lithium battery with a shelf life of 10 years is used.

### 1-3. CONFIGURATION.

The Model 4300 RF Power Meter is a chassis that contains six module slots for installation of the 4300 input modules,

and a seventh calibrator slot. The 4300 may be configured as follows:

- 4300 Chassis.
- 06 Internal TMA (MATE) Option.
- 4312 Thermocouple Channel Module.  
(The 4312 cannot be used with diode sensors).
- 4321 30 MHz Programmable Calibrator Module,  
(Front output).
- 4322 30 MHz Programmable Calibrator Module,  
(Rear output).
- 4323 50 MHz (0 dBm) Power Reference Module,  
(Front output).
- 4324 50 MHz (0 dBm) Power Reference Module,  
(Rear output).
- 4311 Universal Channel Module.

4300 Sensors. Application dependent. Refer to the 4300 Sensor Chart.

1. From one to six input modules may be installed, which may be any combination of 4311 General Purpose Input Channel Modules and 4312 Thermocouple Input Channel Modules. At least one module is required for the 4300 to operate.

2. Zero, one or two calibrators may be installed, one each in the front and rear mounting locations. If only one calibrator is required, either the 4321/22 30 MHz Programmable Calibrator Module or the 4323/24 50 MHz 0 dBm Power Reference Module may be installed. If two are needed, the valid combinations of these four modules that may be installed are:

- 1 - 4321 30 MHz Calibrator (front) and 1 - 4324 50 MHz Reference (rear)
- 1 - 4323 50 MHz Reference (front) and 1 - 4322 30 MHz Calibrator (rear)
- 1 - 4323 50 MHz Reference (front) and 1 - 4324 50 MHz Reference (rear)

### 1-4. ACCESSORIES.

The following accessories are supplied with the instrument:  
**AC power cord.**  
**Fuse kit** for 220/240 VAC.

The following accessories are available for the Model 4300:  
**41-2A/10 Sensor/Probe Interconnecting Cable.**  
(10 ft.) (m/m). A special low noise cable that connects the power sensor to the power meter.

**41-2A/20 Sensor/Probe Interconnecting Cable.**  
(20 ft.).

Section 1  
General Information

**41-2A/50 Sensor/Probe Interconnecting Cable.**  
(50 ft.).

**41-2A/100 Sensor /Probe Interconnecting Cable.**  
(100 ft.).

**950043 Chassis slide rack mounting kit.**

**1-5. SENSORS.**

The Series 4300 sensors are not supplied with the instrument, and must be ordered separately. Both diode and thermal sensors are available which span a power range of -70 to +33 dBm, and a frequency range of 100 kHz to 110 GHz. Refer to the Boonton RF & Microwave Power Sensor Manual for sensor data, and to select a power sensor which best suits your application. These sensors have been fully characterized at the factory, and if they are ordered with the Model 4300, the instrument will be shipped with the sensor calibration data programmed into its nonvolatile memory. If additional sensors are required after the instrument is in the field, the new calibration data provided with the sensor can be entered by the user.

**1-6. OPTIONS.**

**Rack mount hardware kits.**

The following options are available for the instrument:

**4311 Universal Channel Module.** For use with diode or thermal sensors. Both universal and thermal channels may operate simultaneously with a total of six channels installed.

**4312 Thermal Channel Module.** For use with thermal sensors only. Six thermal channels may be used simultaneously or in combination with universal channel modules.

**4321 30 MHz Programmable Calibrator Module.** Provides a 30 MHz, -60 to +20 dBm calibrator signal with front output. Field installable.

**4322 30 MHz Programmable Calibrator Module.** Provides a 30 MHz, -60 to +20 dBm calibrator signal with rear output. Field installable.

**4323 50 MHz (0 dBm) Power Reference Module.** Provides a 50 MHz, 0 dBm calibrator signal with front output. Field installable.

**4324 50 MHz (0 dBm) Power Reference Module.** Provides a 50 MHz, 0 dBm calibrator signal with rear output. Field installable.

**-06 TMA (MATE).**

**1-7. SPECIFICATIONS.**

Model 4300 performance specifications are listed in Table 1-1.

**TABLE 1-1. SPECIFICATIONS**

|                                        |                                                                                                                                                                                                                                                                                                                                                                                                                                                                                                                                                                                                        |                    |                                       |
|----------------------------------------|--------------------------------------------------------------------------------------------------------------------------------------------------------------------------------------------------------------------------------------------------------------------------------------------------------------------------------------------------------------------------------------------------------------------------------------------------------------------------------------------------------------------------------------------------------------------------------------------------------|--------------------|---------------------------------------|
| <b>Frequency Range:</b>                | 100 kHz to 110 GHz, sensor dependent                                                                                                                                                                                                                                                                                                                                                                                                                                                                                                                                                                   |                    |                                       |
| <b>Power Range:</b>                    | -70 dBm to +33 dBm, sensor dependent.<br>-70 dBm with reduced accuracy.                                                                                                                                                                                                                                                                                                                                                                                                                                                                                                                                |                    |                                       |
| <b>Power Sensors:</b>                  | Compatible with all Boonton diode and thermal sensors. Refer to Sensor Manual for sensor characteristics.                                                                                                                                                                                                                                                                                                                                                                                                                                                                                              |                    |                                       |
| <b>Dynamic Range:</b>                  | 70 to 90 dB with diode sensors. Refer to Sensor Manual for sensor characteristics.<br>50 dB with thermocouple sensors.                                                                                                                                                                                                                                                                                                                                                                                                                                                                                 |                    |                                       |
| <b>Inputs:</b>                         | Front and Rear panel inputs standard for each channel module installed.<br>Each channel is an independent measuring unit. One to six channels.<br><br>GPIB connector.                                                                                                                                                                                                                                                                                                                                                                                                                                  |                    |                                       |
| <b>Rear Panel Outputs:</b>             | Type BNC connector(s), one for each channel module installed; the output is front panel/<br>GPIB selectable for linear or logarithmic output proportional to function selected (0 to 10V).<br>Can also be selected for high/low limit status and zero status.                                                                                                                                                                                                                                                                                                                                          |                    |                                       |
| <b>Measurement Modes:</b>              | Single Channel; Summation Channel (Ratio); and Multiple Channel, (all channels displayed simultaneously).                                                                                                                                                                                                                                                                                                                                                                                                                                                                                              |                    |                                       |
| <b>Display Units:</b>                  | Absolute; Watts, dBm.<br>Ratio (summation); dB or %.<br>(Channel 1 ± Channel 2 ± Channel 3 ± Channel n).<br>Relative; dBr.                                                                                                                                                                                                                                                                                                                                                                                                                                                                             |                    |                                       |
| <b>Resolution:</b>                     | Watts, in nW μW, mW, W, (4 1/2 digits).<br>dBm/dB, .01 dB.                                                                                                                                                                                                                                                                                                                                                                                                                                                                                                                                             |                    |                                       |
| <b>Display:</b>                        | Alphanumeric backlit LCD, 2 lines of 40 characters each.                                                                                                                                                                                                                                                                                                                                                                                                                                                                                                                                               |                    |                                       |
| <b>Instrument:</b>                     | <b>Uncertainty (1)</b>                                                                                                                                                                                                                                                                                                                                                                                                                                                                                                                                                                                 | <b>RSS</b>         | <b>Worst Case</b>                     |
|                                        | Single Channel Mode (2)                                                                                                                                                                                                                                                                                                                                                                                                                                                                                                                                                                                | 0.12% (0.005 dB)   | 0.3% (0.013 dB)                       |
|                                        | Zeroing                                                                                                                                                                                                                                                                                                                                                                                                                                                                                                                                                                                                | 0.01% (.0005 dB)   | 0.025% of F.S.                        |
|                                        | Shaping (3)                                                                                                                                                                                                                                                                                                                                                                                                                                                                                                                                                                                            | 0.015% (0.0007 dB) | 0.12% (.005 dB)                       |
|                                        | Total uncertainty                                                                                                                                                                                                                                                                                                                                                                                                                                                                                                                                                                                      | 0.14% (0.006 dB)   | 0.42% + .025% of F.S.<br>(0.67% Max.) |
|                                        | <p>(1) Total measurement uncertainty is the sum of Instrument uncertainty, Power Reference/Calibrator uncertainty, Noise and Calibration Factor uncertainty and Power Linearity uncertainty. The most probable uncertainty is the RSS of these uncertainties. Refer to the Boonton "RF &amp; Microwave Power Sensor Manual" for Calibration Factor uncertainty, Sensor Noise and Power Linearity Uncertainty.</p> <p>(2) Accuracy in Summation (Ratio) mode is n x single channel where n = number of channels.</p> <p>(3) Add 1% (.04 dB) when using 50 MHz Power Reference or Waveguide sensors.</p> |                    |                                       |
| <b>Power Reference/Calibrator</b>      |                                                                                                                                                                                                                                                                                                                                                                                                                                                                                                                                                                                                        |                    |                                       |
| <b>50 MHz (0 dBm) Power Reference:</b> | Internal 50 MHz source with type N female connector. 0 dBm (1.00 mW) factory set to ±0.7% (.03 dB) at 0 dBm. Front or rear panel. 18-28°C. VSWR 1.05. The worst case uncertainty for one year is 1.2% (0.9% RSS) 0-55°C.                                                                                                                                                                                                                                                                                                                                                                               |                    |                                       |
| <b>30 MHz Programmable Calibrator:</b> | Internal 30 MHz source with programmable level between -60 dBm and +20 dBm, 1 dB steps. Front or rear panel. 20 - 30°C. At 0-20° and 30-50°C add 0.35% (.015 dB).                                                                                                                                                                                                                                                                                                                                                                                                                                      |                    |                                       |



**TABLE 1-1. SPECIFICATIONS (CONT.)**

|                                                    |                                                                                                                                                                                                                                                                                                                                                                                                |                      |                        |
|----------------------------------------------------|------------------------------------------------------------------------------------------------------------------------------------------------------------------------------------------------------------------------------------------------------------------------------------------------------------------------------------------------------------------------------------------------|----------------------|------------------------|
| <b>30 MHz Programmable Calibrator Uncertainty:</b> | <b>Level</b>                                                                                                                                                                                                                                                                                                                                                                                   | <b>RSS</b>           | <b>Worst Case</b>      |
|                                                    | @ 0 dBm                                                                                                                                                                                                                                                                                                                                                                                        | 0.6% (.025 dB)       | 0.9% (.04 dB)          |
|                                                    | +20 dBm to -39 dBm                                                                                                                                                                                                                                                                                                                                                                             | 0.7% (.03 dB)        | 1.4% (.06 dB)          |
|                                                    | -40 dBm to -60 dBm                                                                                                                                                                                                                                                                                                                                                                             | 0.9% (.04 dB)        | 2.1% (.09 dB)          |
|                                                    | VSWR 1.05                                                                                                                                                                                                                                                                                                                                                                                      |                      |                        |
| <b>Calibration Factors:</b>                        | +3 dB to -3 dB in .01 dB steps. These calibration factors are stored in nonvolatile memory. When a frequency other than that stored is used, the 4300 linearly interpolates between the cal factor above and below the frequency entered to obtain a cal factor. Cal factors for up to 20 sensors can be stored with up to 80 frequencies for sensors 1-6 and 35 frequencies for sensors 7-20. |                      |                        |
| <b>Ranging:</b>                                    | Autoranging, set-ranging and hold on range, each channel operating independently. 10% headroom. Hold on range: 25 dB dynamic range on each range; 0.2 dB resolution at -25 dB point.                                                                                                                                                                                                           |                      |                        |
| <b>Settling Time:</b>                              | 0-99%, 10 dB power step, hold range, filter set to 20 ms. Readout over the GPIB:<br>Diode sensors: <200 ms<br>Thermocouple sensors: <450 ms                                                                                                                                                                                                                                                    |                      |                        |
| <b>Output Data Speed:</b>                          | Free run access time is typically 30 ms per channel or 33 readings per second.                                                                                                                                                                                                                                                                                                                 |                      |                        |
| <b>Filtering:</b>                                  | Filtering is selected by entering the filter time in ms, between 20 ms and 20 seconds. Filtering is accomplished in 20 ms increments, e.g., selecting 2000 ms selects 100 point averaging. Auto filtering selects the following default values:                                                                                                                                                |                      |                        |
|                                                    |                                                                                                                                                                                                                                                                                                                                                                                                | <b>Diode Channel</b> | <b>Thermal Channel</b> |
|                                                    | <b>Range</b>                                                                                                                                                                                                                                                                                                                                                                                   | <b>filter time</b>   | <b>filter time</b>     |
|                                                    | 0                                                                                                                                                                                                                                                                                                                                                                                              | 2.8 sec              | 4.8 sec                |
|                                                    | 1                                                                                                                                                                                                                                                                                                                                                                                              | 0.8                  | 1.8 sec                |
|                                                    | 2                                                                                                                                                                                                                                                                                                                                                                                              | 0.3                  | 0.6                    |
|                                                    | 3                                                                                                                                                                                                                                                                                                                                                                                              | 0.06                 | 0.3                    |
|                                                    | 4                                                                                                                                                                                                                                                                                                                                                                                              | 0.06                 | ---                    |
|                                                    | 5                                                                                                                                                                                                                                                                                                                                                                                              | 0.06                 | ---                    |
|                                                    | 6                                                                                                                                                                                                                                                                                                                                                                                              | 0.06                 | ---                    |
|                                                    | Measurement time is the sum of settling time and filter time.                                                                                                                                                                                                                                                                                                                                  |                      |                        |
| <b>Zeroing:</b>                                    | Each range is independently zeroed upon selecting the "ZERO" function either via front panel or over the GPIB.                                                                                                                                                                                                                                                                                 |                      |                        |
| <b>Limits:</b>                                     | Front panel or GPIB selectable between 99.9 and -99.9 dBm, independently for each channel.                                                                                                                                                                                                                                                                                                     |                      |                        |
| <b>GPIB Interface:</b>                             | Complies with IEEE-488 standards. The following functions are implemented: SH1, Ah1, T6, L4, SR1, R11 DC1 and DT1.                                                                                                                                                                                                                                                                             |                      |                        |
| <b>Power Consumption:</b>                          | 40 VA; 100, 120, 220, 240V ± 10%, 50 - 400 Hz.                                                                                                                                                                                                                                                                                                                                                 |                      |                        |
| <b>Weight:</b>                                     | 21 lbs (9.5 kg) With 6 channels and programmable calibrator.                                                                                                                                                                                                                                                                                                                                   |                      |                        |
| <b>Dimensions:</b>                                 | 3.48 in (8.8 cm) high, 17.24 in (43.8 cm) wide, and 17.75 in (45.0 cm) deep.                                                                                                                                                                                                                                                                                                                   |                      |                        |
| <b>Environmental Characteristics:</b>              | Meets MIL-T-28800C for Type II, Class 5, Style E and F equipment.                                                                                                                                                                                                                                                                                                                              |                      |                        |

**TABLE 1-1. SPECIFICATIONS (CONT.)**

|                      |                                                                                                                                                                  |
|----------------------|------------------------------------------------------------------------------------------------------------------------------------------------------------------|
| <b>Temperature</b>   | Operating: 0 to 55°C<br>Non-operating: -40 to 75°C                                                                                                               |
| <b>Altitude:</b>     | Operating: 10,000 ft<br>Non-Operating: 15,000 ft                                                                                                                 |
| <b>Humidity:</b>     | 95% (non-condensing)                                                                                                                                             |
| <b>Battery Type:</b> | Refer to page 7-2                                                                                                                                                |
| <b>CE Mark:</b>      | Declares Conformity to European Community (EC) Council Directives:<br>89/336/EEC//93/68/EEC, 73/23/EEC//93/68/EEC & Standards:<br>EN55011, EN50082-1, EN61010-1. |

## SECTION 2 INSTALLATION

### 2-1. INTRODUCTION.

This section contains instructions for the installation of the Model 4300 RF Powermeter, and for installation of the Input channels and the calibrators.

### 2-2. UNPACKING.

The Model 4300 is shipped complete and is ready to use upon receipt. Unpack the instrument from its shipping container and inspect it for damage that may have occurred during shipment. See Figure 2-1.

### NOTE

Save the packing material and container for possible use in reshipment of the instrument.

### 2-3. MOUNTING.

For bench mounting, choose a clean, sturdy, uncluttered mounting surface. For rack mounting, an accessory kit is available that provides mounting ears and handles along with the necessary hardware and instructions.

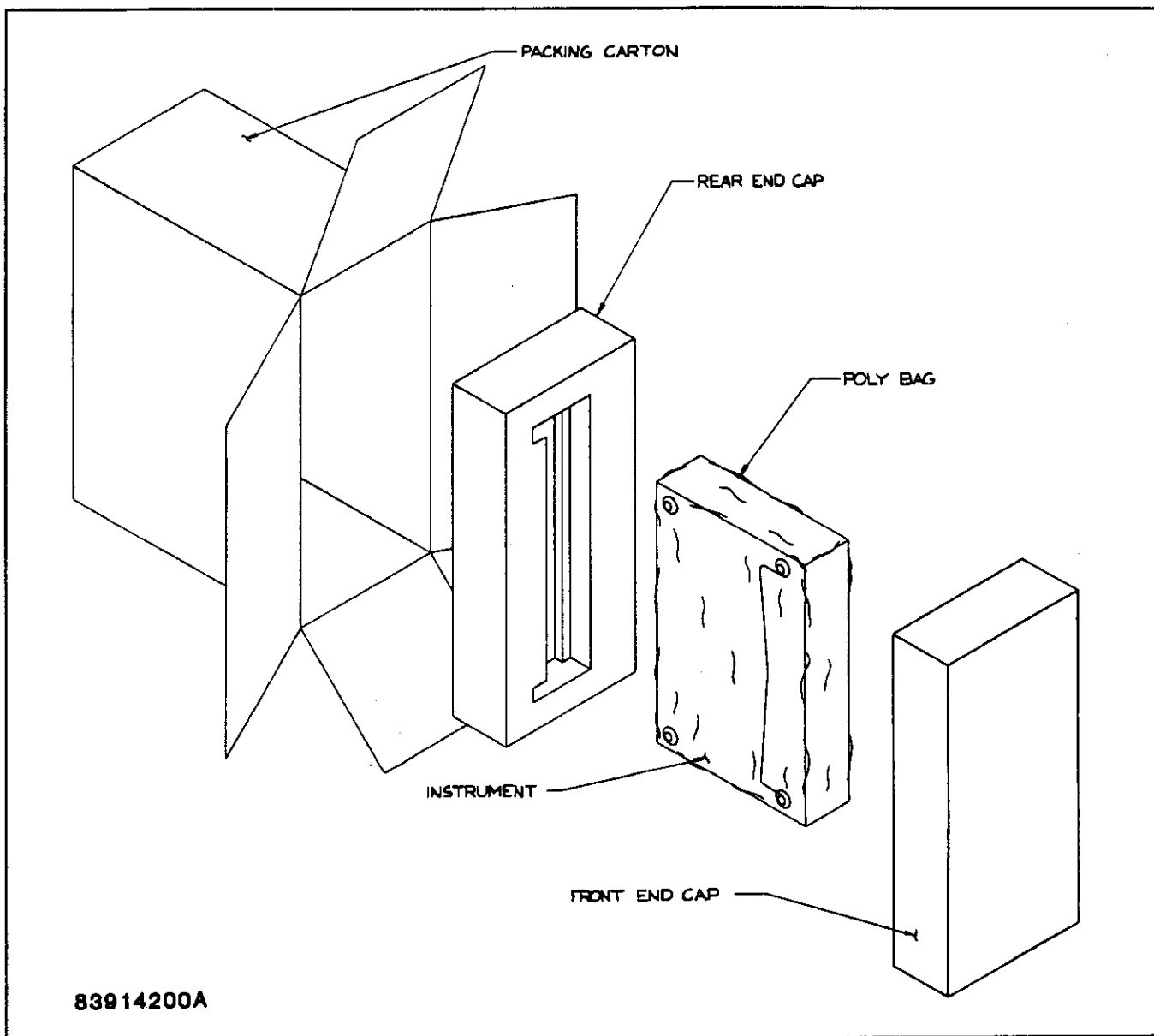

Figure 2-1. Packing and Unpacking Diagram

## 2-4. CALIBRATOR AND INPUT CHANNEL INSTALLATION.

For installation instructions of the 30 MHz and 50 MHz calibrator options, and the input channels, refer to Figures 2-2, 2-3, 2-4, and 2-5. Early units require that the keyboard be removed to install a calibrator in the front location.

## 2-5. POWER REQUIREMENTS.

The Model 4300 has a tapped power transformer and two line voltage selection switches which permit operation from 100, 120, 220, and 240 volt  $\pm$  10%, 50 to 60 Hz, single phase AC power sources. Power consumption is approximately 40 VA.

The 4300 Power Meter may also be configured to operate with a 400 Hz line. The instrument is set up for 50/60 Hz operation at the factory, with the internal signal processing synchronized to the AC line for maximum rejection of line frequency noise and interference. For operation at 400 Hz, this synchronization is not possible, and the internal clock must be used. Refer to Section 6, Maintenance for changing the operating frequency.

### CAUTION

Always make certain that the line voltage selector switches are set to the correct positions most nearly corresponding to the voltage of the available AC power source, and that a fuse of the correct rating is installed in the fuse holder before connecting the Model 4300 to any AC power source.

Set the line voltage selector switches, located on the rear panel to the appropriate positions as indicated on the LINE VOLTAGE SELECT chart located next to the switches. Check that the line fuse is correct for the selected power source. The correct fuse is:

| VOLTAGE  | FUSE              |
|----------|-------------------|
| 100/120V | 3/4 A T (Slø-Blo) |
| 220/240V | 3/8 A T (Slø-Blo) |

## 2-6. CABLE CONNECTIONS.

Cable connections required depend on the use of the instrument. Refer to Section 3, Operation, for descriptions of the connections.

## 2-7. PRELIMINARY CHECKOUT.

This preliminary checkout verifies the basic functionality of the Model 4300 using its built-in diagnostic tests. A complete

verification of performance procedure may be found in the Section 6, Maintenance "Performance Verification".

### WARNING

The instrument must first be set to the proper line voltage. Refer to Section 2-5, or use the rear panel markings as a guide.

The procedure for checkout is as follows:

1. Connect the instrument to the AC line and turn on power using the front panel switch.
2. Press SHIFT, RECALL, 0, ENTER. This initializes the instrument to its default settings.
3. Press TEST, 1, ENTER to initiate the keyboard test. When any key is pressed (except ESCAPE), the display should read a number from 1 to 30. Starting with the ENTRY key, press each key in sequence, from left to right, and top to bottom, and make sure that each keypress is indicated by a unique number. Press ESCAPE to exit the test.
4. Press TEST, 2, ENTER to execute the display test. The LCD display should light up all pixels of all characters for several seconds, then show the full character set used in the 4300. Make sure that all pixels function, and that the display characters are clearly visible. If necessary, the LCD contrast may be adjusted with a small screwdriver using the "Display" potentiometer next to the LCD readout.
5. Press TEST, 3, ENTER to check the internal memory. The display should indicate **MEMORY OK**.
6. Press TEST, 7, ENTER to check the battery voltage. The display should indicate **BATTERY TEST OK**.
7. If the 30 MHz calibrator is installed, press LEVEL, 0, ENTER. Press ON/OFF to enable the calibrator output.
8. Connect a general purpose power meter to the 30 MHz or 50 MHz calibrator if installed and verify its level to be 0 +/- 0.2 dBm.

For verification of the input channels and sensors, sensor assignment must be verified first, and it must be ascertained that each sensor's "14 point linearity data" has been entered into the 4300's memory. Refer Section 3, Operation for those procedures.

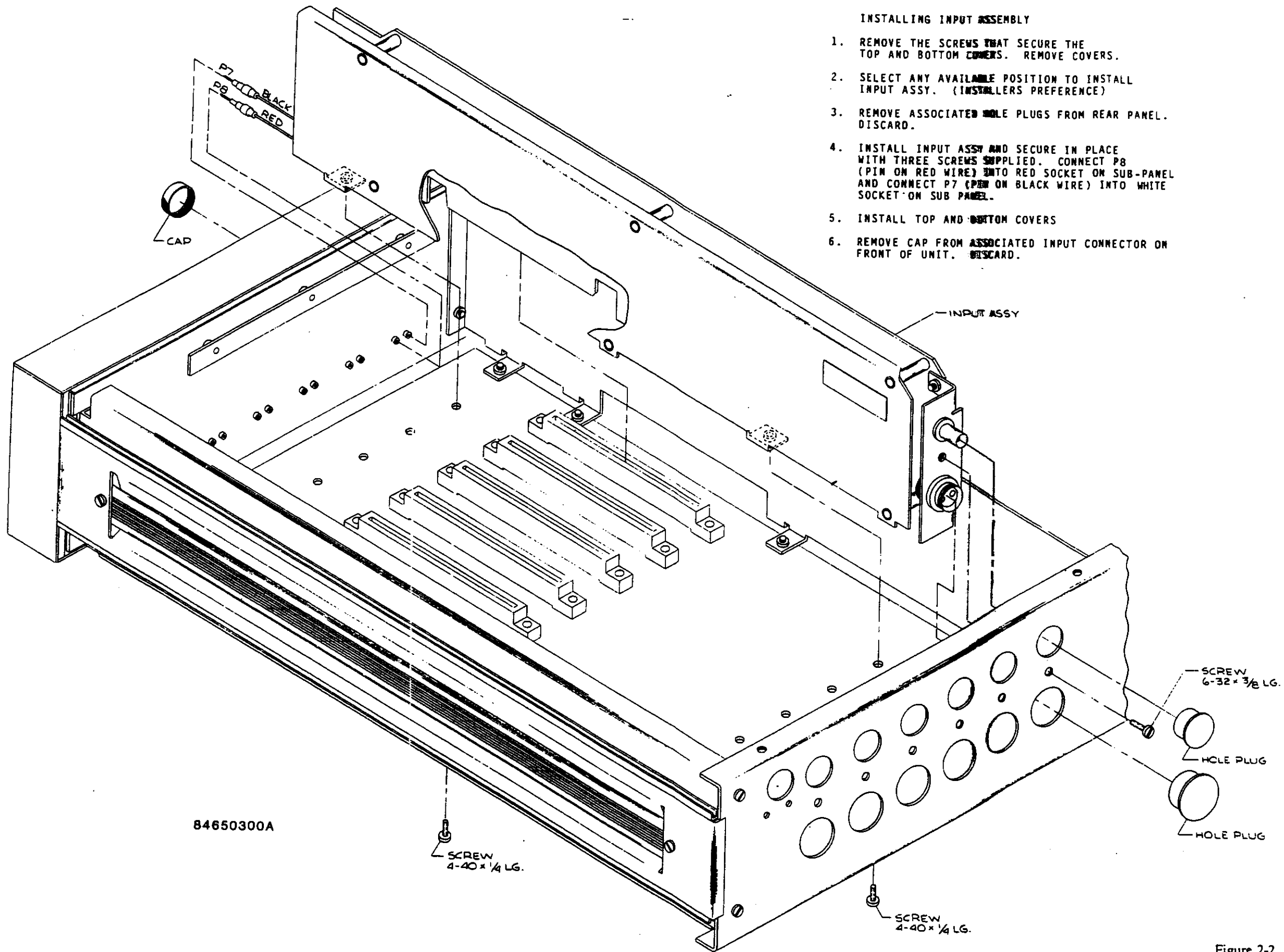

- INSTALLING INPUT ASSEMBLY
1. REMOVE THE SCREWS THAT SECURE THE TOP AND BOTTOM COVERS. REMOVE COVERS.
  2. SELECT ANY AVAILABLE POSITION TO INSTALL INPUT ASSY. (INSTALLERS PREFERENCE)
  3. REMOVE ASSOCIATED HOLE PLUGS FROM REAR PANEL. DISCARD.
  4. INSTALL INPUT ASSY AND SECURE IN PLACE WITH THREE SCREWS SUPPLIED. CONNECT P8 (PIN ON RED WIRE) INTO RED SOCKET ON SUB-PANEL AND CONNECT P7 (PIN ON BLACK WIRE) INTO WHITE SOCKET ON SUB-PANEL.
  5. INSTALL TOP AND BOTTOM COVERS
  6. REMOVE CAP FROM ASSOCIATED INPUT CONNECTOR ON FRONT OF UNIT. DISCARD.

Figure 2-2. Input Module Installation

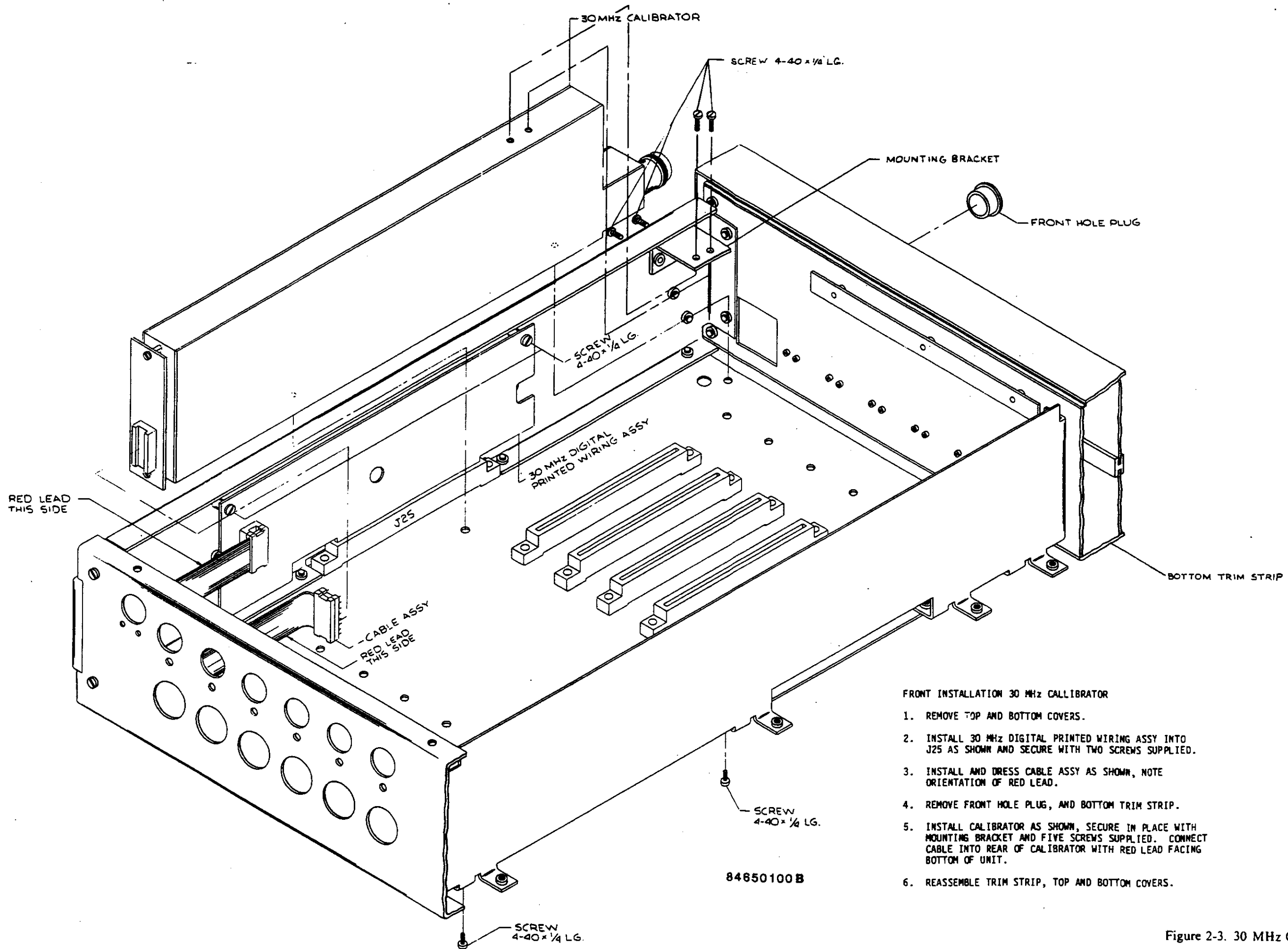

FRONT INSTALLATION 30 MHz CALIBRATOR

1. REMOVE TOP AND BOTTOM COVERS.
2. INSTALL 30 MHz DIGITAL PRINTED WIRING ASSY INTO J25 AS SHOWN AND SECURE WITH TWO SCREWS SUPPLIED.
3. INSTALL AND DRESS CABLE ASSY AS SHOWN, NOTE ORIENTATION OF RED LEAD.
4. REMOVE FRONT HOLE PLUG, AND BOTTOM TRIM STRIP.
5. INSTALL CALIBRATOR AS SHOWN, SECURE IN PLACE WITH MOUNTING BRACKET AND FIVE SCREWS SUPPLIED. CONNECT CABLE INTO REAR OF CALIBRATOR WITH RED LEAD FACING BOTTOM OF UNIT.
6. REASSEMBLE TRIM STRIP, TOP AND BOTTOM COVERS.

Figure 2-3. 30 MHz Calibrator Installation (Front)

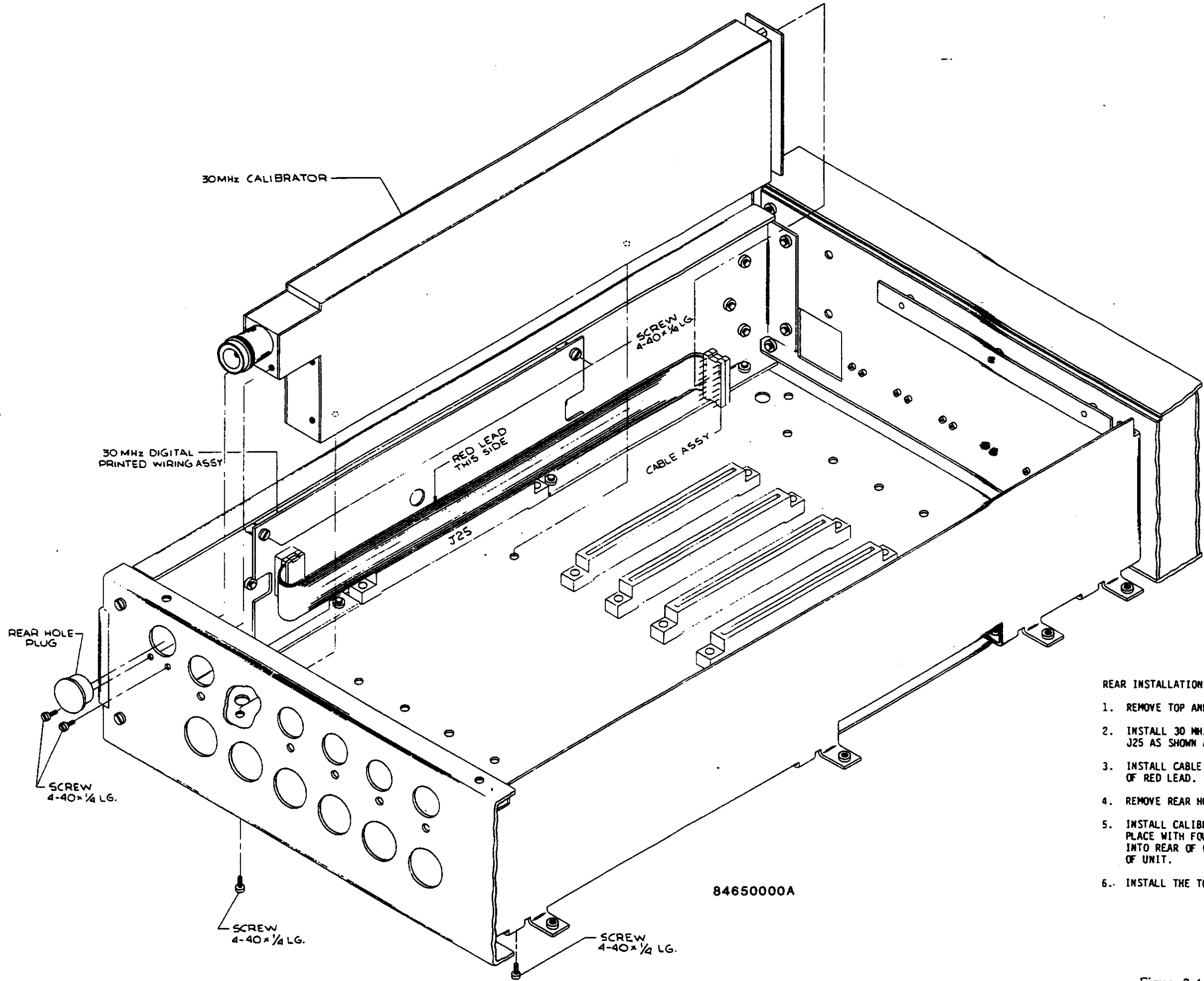

REAR INSTALLATION 30 MHz CALIBRATOR

1. REMOVE TOP AND BOTTOM COVERS.
2. INSTALL 30 MHz DIGITAL PRINTED WIRING ASSY INTO J25 AS SHOWN AND SECURE WITH TWO SCREWS SUPPLIED.
3. INSTALL CABLE ASSY AS SHOWN, NOTE ORIENTATION OF RED LEAD.
4. REMOVE REAR HOLE PLUG.
5. INSTALL CALIBRATOR AS SHOWN AND SECURE IN PLACE WITH FOUR SCREWS SUPPLIED. CONNECT CABLE INTO REAR OF CALIBRATOR WITH RED LEAD FACING TOP OF UNIT.
6. INSTALL THE TOP AND BOTTOM COVERS.

Figure 2-4. 30 MHz Calibrator Installation (Rear)

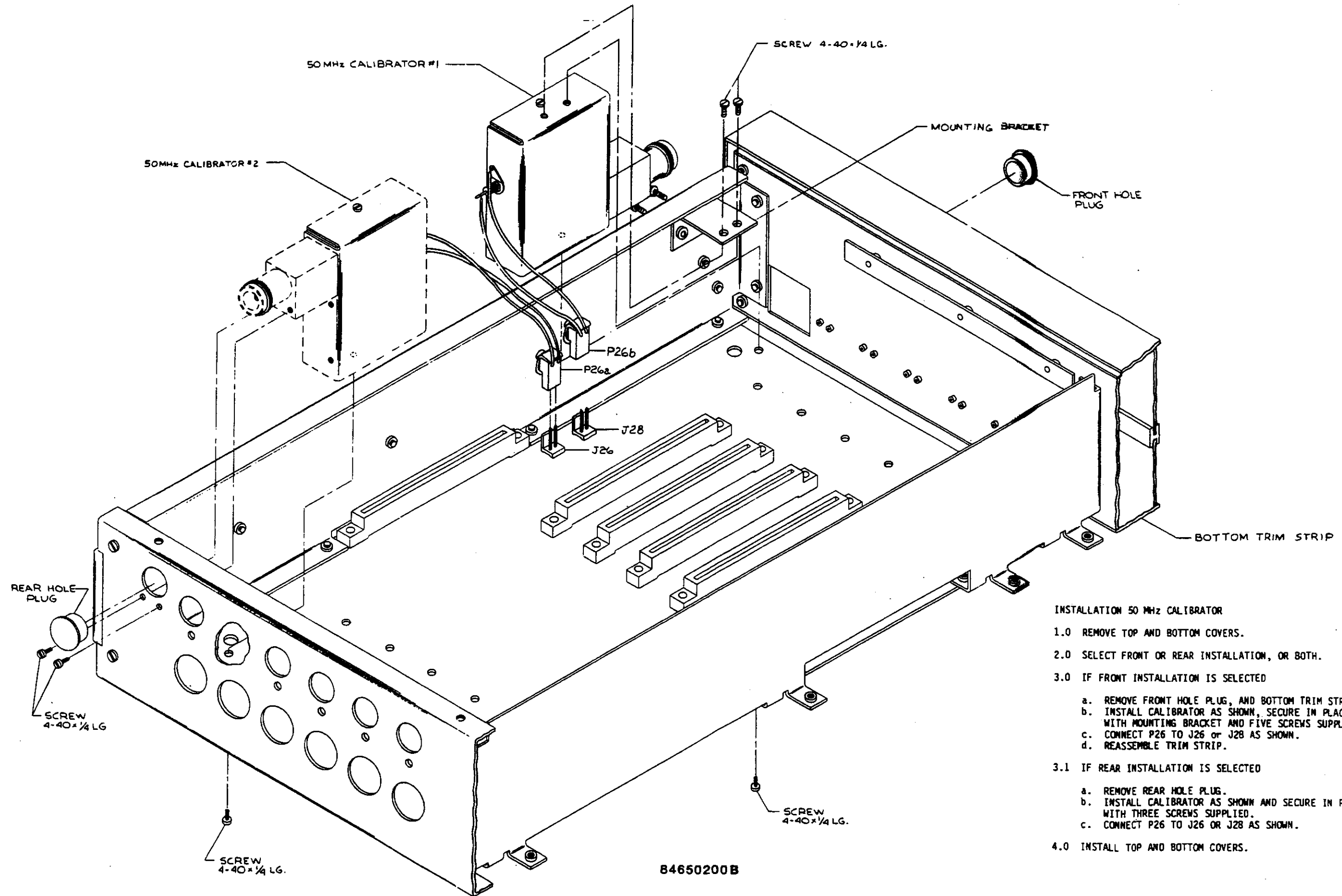

INSTALLATION 50 MHz CALIBRATOR

- 1.0 REMOVE TOP AND BOTTOM COVERS.
- 2.0 SELECT FRONT OR REAR INSTALLATION, OR BOTH.
- 3.0 IF FRONT INSTALLATION IS SELECTED
  - a. REMOVE FRONT HOLE PLUG, AND BOTTOM TRIM STRIP.
  - b. INSTALL CALIBRATOR AS SHOWN, SECURE IN PLACE WITH MOUNTING BRACKET AND FIVE SCREWS SUPPLIED.
  - c. CONNECT P26 TO J26 OR J28 AS SHOWN.
  - d. REASSEMBLE TRIM STRIP.
- 3.1 IF REAR INSTALLATION IS SELECTED
  - a. REMOVE REAR HOLE PLUG.
  - b. INSTALL CALIBRATOR AS SHOWN AND SECURE IN PLACE WITH THREE SCREWS SUPPLIED.
  - c. CONNECT P26 TO J26 OR J28 AS SHOWN.
- 4.0 INSTALL TOP AND BOTTOM COVERS.

Figure 2-5. 50 MHz Calibrator Installation



## SECTION 3 OPERATION

### 3-1. INTRODUCTION.

This section contains the operating instructions for the Model 4300, and a description of its controls, indicators, and connectors.

### 3-2. OPERATING CONTROLS, INDICATORS, AND CONNECTORS.

The controls, indicators, and connectors are listed in Table 3-1 and shown in Figures 3-1, 3-2, and 3-3.

### 3-3. OPERATING INSTRUCTIONS.

The operating instructions for the Model 4300 are as follows:

1. Initializing.
2. Local Operation.
3. Remote (GPIB) Operation.

### 3-4. INITIALIZING.

Initialize the Model 4300 as follows:

1. Connect the power cord to the instrument and the desired power source. Refer to Section 2, Installation, for the proper power application.
2. Set the LINE ON/OFF switch to ON.
3. Wait a few seconds until the instrument initializes, press SHIFT, RECALL, 0, ENTER, to set the following conditions.
  - Single channel, channel 1.
  - Auto range.
  - Calibrator Off, level at -60 dBm, max limit at +10 dBm. dBm mode.
  - Duty cycle = 100%.
  - Peak mode disabled.
  - Frequency = 30 MHz.
  - dB cal factor = 0 dB.
  - dB reference = 0 dB
  - High limit = 99.99 dBm.
  - Low limit = -99.99 dBm.

**TABLE 3-1. OPERATING CONTROLS, INDICATORS AND CONNECTORS**

| Control, Indicator or Connector | Figure and Index No. | Function                                            |
|---------------------------------|----------------------|-----------------------------------------------------|
| LINE ON/OFF switch              | 3-1, 1               | Switches the AC power ON and OFF.                   |
| Display                         | 3-1, 2               | Adjusts the LCD display contrast.                   |
| INSTRUMENT KEYBOARD             | 3-1, 3               | See "SPECIFIC KEY OPERATION".                       |
| Channel 1-6 connector           | 3-1, 4               | Channel input connectors for 1 to 6 sensors.        |
| Calibrator connector            | 3-1, 5               | Front calibrator output, used to calibrate sensors. |
| Fuseholder                      | 3-2, 1               | AC line fuseholder.                                 |
| AC connector                    | 3-2, 2               | AC power connector.                                 |
| Line Voltage Selector switch    | 3-2, 3               | Selects the desired operating voltage.              |
| IEEE-488 Bus connector          | 3-2, 4               | Connector for IEEE-488 (GPIB) interface cable.      |
| Mode switch                     | 3-2, 5               | Sets calibration, reset, and miscellaneous options. |
| Sensor 1-6 connectors           | 3-2, 6               | Alternate sensor inputs.                            |
| Recorder out 1-6 connectors     | 3-2, 7               | DC outputs 0 - 10 VDC.                              |
| Calibrator out connector        | 3-2, 8               | Rear panel 30 or 50 MHz calibrator output.          |

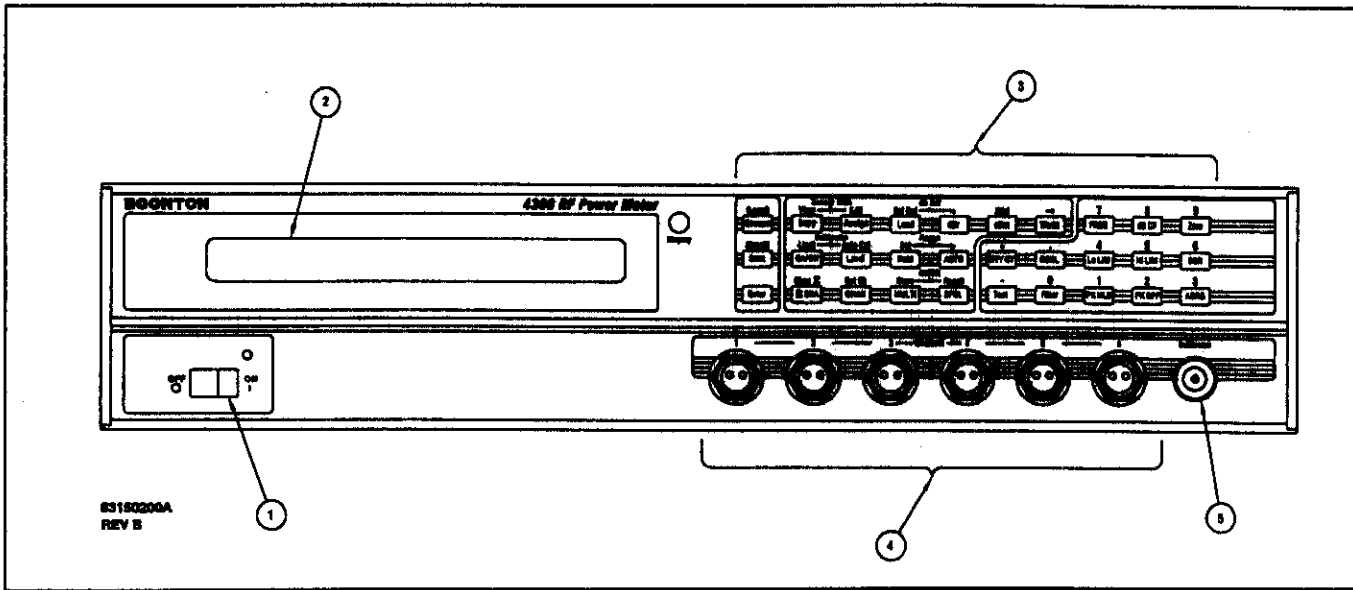

Figure 3-1. 4300 Front Panel

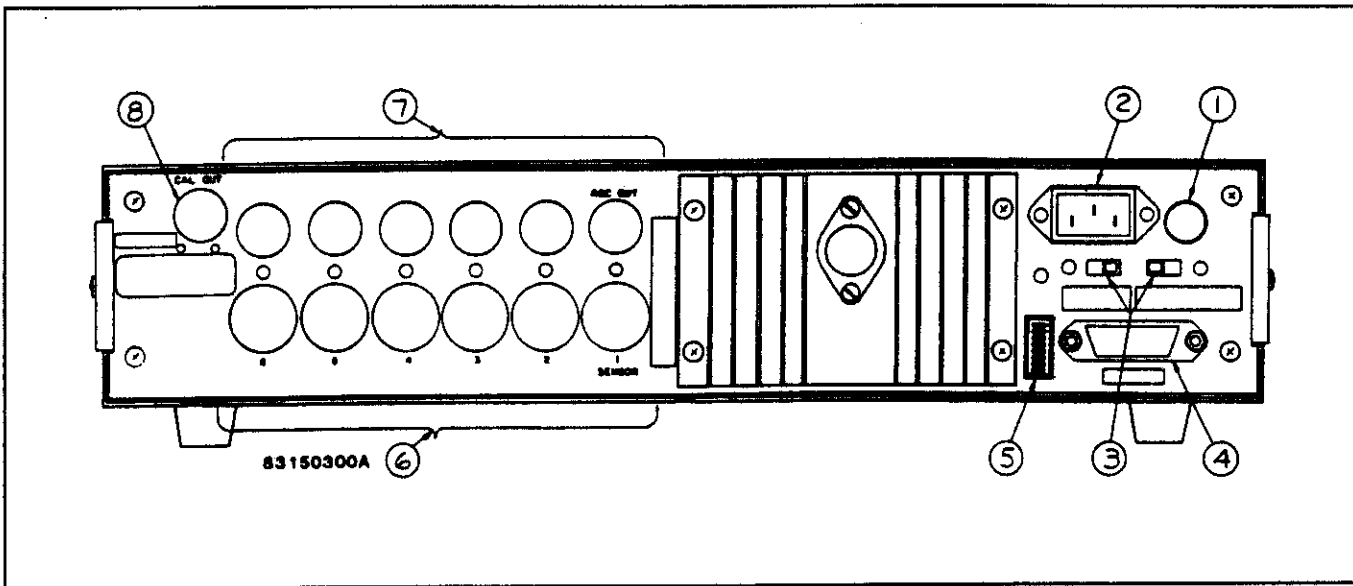

Figure 3-2. Rear Panel

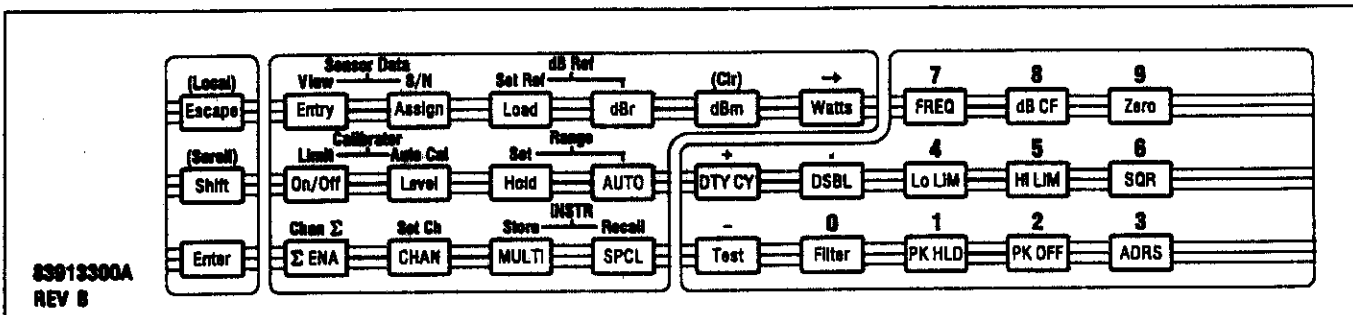

Figure 3-3. Front Panel Keys

Chart recorder scaling from -60 dBm to + 20 dBm  
Default filters as shown:

| Range | Diode Channels | Thermal Channels |
|-------|----------------|------------------|
| 0     | 2.8 sec        | 4.8              |
| 1     | 0.8            | 1.8              |
| 2     | 0.3            | 0.6              |
| 3     | .06            | 0.3              |
| 4     | .06            | ---              |
| 5     | .06            | ---              |
| 6     | .06            | ---              |

Free run (untriggered) mode.  
Channel summation (ratio) set for Ch 1 - Ch 2.  
Trigger delay = 130 ms.

### 3.5. LOCAL OPERATION.

#### NOTE

Basic operation is shown below. For use of all the functions, refer to Table 3-2, 3-3, and 3-4, and to the paragraph on Specific Key Operation.

### 3-6. SINGLE CHANNEL OPERATION.

1. Initialize the instrument as described in Paragraph 3-4. This operation does not need to be done every time the instrument is used. Once the instrument has been initialized the setup conditions are stored. Also, the rear panel bit switch can be set up so that the instrument initializes every time power is applied (set position 8 to OPEN). Refer to Figure 3-4 for a Single Channel Operation Display (sample).

2. Connect a power sensor using the supplied cable, to the input channel to be used (front or rear connector). The unused connector for a particular channel should have a grounding cap to prevent noise.

3. Select Single Channel mode and the channel to be displayed by pressing SHIFT, SET CH, #, ENTER where # is the channel (1-6) to be selected.

4. Assign the sensor to be used to the channel by pressing SHIFT, SENSOR DATA S/N, #####, ENTER, where ##### is the sensor serial number. Alternatively, if the sensor

TABLE 3-2. CHANNEL PARAMETERS

| Parameter                         | Refer to Key(s)         |
|-----------------------------------|-------------------------|
| Range                             | RANGE SET               |
| Range Mode (hold or auto)         | RANGE HOLD, RANGE AUTO  |
| Watts / dBm / dBr Mode            | WATTS, dBm, dBr         |
| dB Reference                      | dB REF LOAD, dB SET REF |
| Duty Cycle and Duty Cycle Enabled | DTY CY, DSBL*           |
| Peak Hold Enabled                 | PK HLD, PK OFF          |
| Frequency                         | FREQ                    |
| dB Cal Factor                     | dB CF                   |
| High and Low Limits               | HI LIM, LO LIM          |
| Chart Recorder Scaling and Mode   | SPECIAL *               |
| Filter Length                     | FILTER *                |
| Trigger Mode (Free Run, etc.)     | SPECIAL *               |
| Trigger Delay                     | SPECIAL *               |
| *See also Table 3-4.              |                         |

TABLE 3-3. ADDITIONAL OPERATIONS

| Operation                     | Refer to Key(s)                                                           |
|-------------------------------|---------------------------------------------------------------------------|
| Zero                          | ZERO *                                                                    |
| 30 MHz Calibrator Operation   | CALIBRATOR LIMIT, CALIBRATOR ON/OFF, CALIBRATOR AUTOCAL, CALIBRATOR LEVEL |
| Store and Recall Panel Setups | INSTR STORE, INSTR RECALL                                                 |
| Bar Graph                     | SPECIAL                                                                   |
| *See also Table 3-4.          |                                                                           |

TABLE 3-4. THEORY OF USE AND APPLICATION

| Topic                    | Refer To  |
|--------------------------|-----------|
| Sensor Calibration       | Section 4 |
| Zeroing                  | "         |
| Filtering                | "         |
| Measurement Time         | "         |
| High Frequency Accuracy  | "         |
| Pulsed RF Measurements   | "         |
| Chart Recorder Operation | "         |
| Triggered Operation      | "         |
| Settled Reading Mode     | "         |

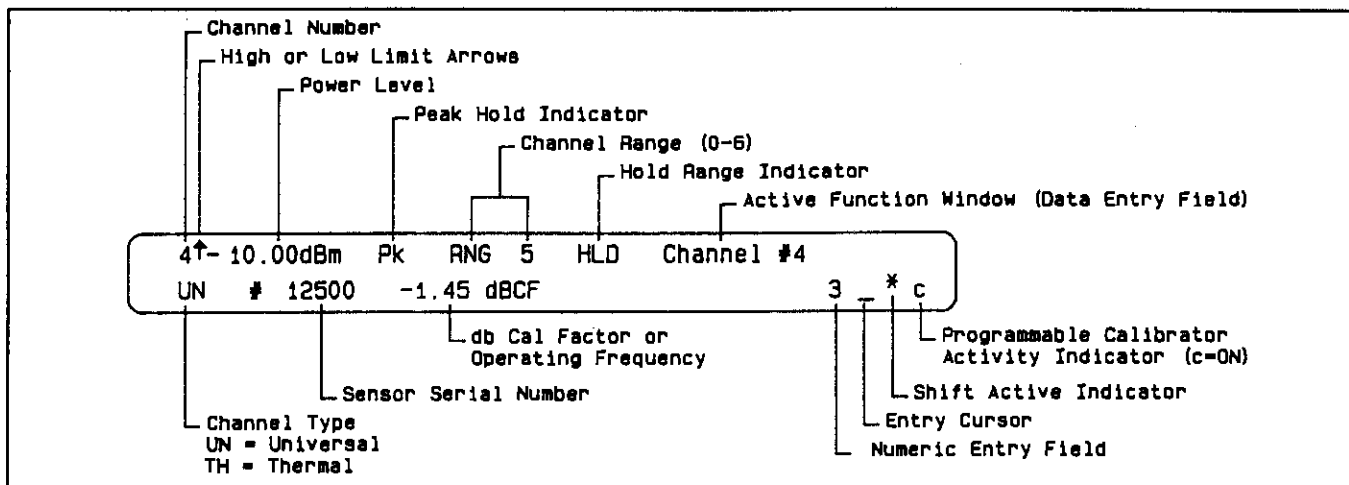

Figure 3-4. Single Channel Display

number is known (1 to 20, arbitrarily assigned at the time the sensor data is entered), press ASSIGN, XX, ENTER, where XX is the sensor number. If the sensor data has not been previously entered into the sensor data bank, refer to the SENSOR DATA ENTRY key (instruments are shipped from the factory with the sensor data entered). To view the sensor assignments and/or correlate serial numbers to sensor numbers, press SHIFT, SENSOR DATA VIEW, 1, ENTER. Then press ENTER repeatedly to scroll through the list of sensors, and ESCAPE to exit. Once sensor assignments are made, they are stored in non-volatile memory and will not be reset by an initialization (RECALL 0) sequence.

5. Connect the sensor to one of the following power reference sources, as available:

1. 50 MHz internal fixed 0 dBm calibrator.
2. 30 MHz internal programmable calibrator.
3. An external fixed calibrator at 0 dBm or -20 dBm.

6. With the sensor connected to the calibrator, press SHIFT, AUTOCAL. When the display prompts, press ENTER. The ENTER keystroke is a safety measure which prevents accidental erasure of previous autocal data. The 4300 will determine which calibrator is connected, if any, and do either a fixed or multilevel calibration as appropriate. The multipoint calibration takes about 100 seconds. Calibration should be done when sensors are reassigned, or any time there is a temperature change. Refer to the CALIBRATOR AUTOCAL key for more detailed information.

**NOTE**

When a 75 ohm sensor is used with the calibrator, compensation must be made for the mismatch. See box 75 OHM SENSOR CALIBRATION Paragraph 3-9.

7. Remove the sensor from the calibrator and wait for 10 to 20 seconds. Press ZERO and wait for the 4300 to complete

the zeroing routine. For maximum accuracy, zero the instrument frequently when making low level measurements.

8. Connect the sensor to the source to be measured and observe the display.

9. Press the WATTS or dBm keys as required.

10. Refer to Table 3-2 for channel parameters that can be modified, Table 3-3 for additional operations that are not channel parameters, and Section 4, Making Measurements for specific aspects of power measurement and applications.

### 3-7. MULTICHANNEL OPERATION.

1. In multichannel operation, the channels are usually set up individually, and the instrument is then put into Multi Channel mode, as shown below.

2. Initialize the instrument as described in paragraph 3-4. This operation does not need to be done every time the instrument is used. Once the instrument has been initialized the setup conditions are stored. Also, the rear panel bit switch can be set up so that the instrument initializes every time power is applied (set position 8 to OPEN). Refer to Figure 3-5 for a Multichannel Operation Display (sample).

3. Connect the power sensors, using the supplied cables, to the input channels to be used (front or rear connectors). All unused sensor connectors should have grounding caps installed to prevent noise.

4. For each channel and sensor, perform steps 2 through 8 in the Single Channel Operation procedure, in Single Channel mode. Each channel is set up with its own set of parameters. Alternatively, channel parameters that are to be common for all channels can be set up once using Multichannel mode.

5. Press MULT1 to enter the Multichannel mode of operation.

6. Remove the sensors from the calibrator and wait for 10 to 20 seconds. Press ZERO and wait for the 4300 to complete the zeroing routine. For maximum accuracy, zero the

instrument frequently when making low level measurements. If some of the channels cannot zero due to a large offset (this can happen if no sensor is connected), an error message will be generated. Pressing ESCAPE will clear the message, however, only the channels that are able to zero will be zeroed. If it is desired to zero only one channel, the instrument can be put in Single Channel mode and zeroed, then returned to Multichannel mode once the channel has completed zeroing.

7. Connect the sensors to the sources to be measured and observe the display.

8. Press the WATTS or dBm key to select the units for displaying power. In Multichannel mode it is possible to have some channels display the power in watts while others display it in dBm.

9. The channel parameters listed in Table 3-2 can be entered simultaneously for all channels in Multichannel mode. If it is desired to enter a parameter for one channel only, temporarily put the instrument in Single Channel mode on the channel desired, set the parameter, and return to Multichannel mode.

10. When the instrument is in Multichannel mode, only the power may be displayed for all channels individually. To view channel parameter settings, it is necessary to return to Single Channel mode. Pressing any of the parameter keys while in Multichannel mode will also display the parameter, but only if all channels have that parameter set to a common value. For example, if several channels are operating on the same frequency, pressing the FREQ key from Multichannel mode will display the current frequency setting for the channels, and allow editing. If they are set for different frequencies, the display field will be blank, and entering a number will set all channels to the new frequency.

11. Refer to Table 3-3 for additional operations that are not channel parameters, and section 4, Making Measurements for specific aspects of power measurement and applications.

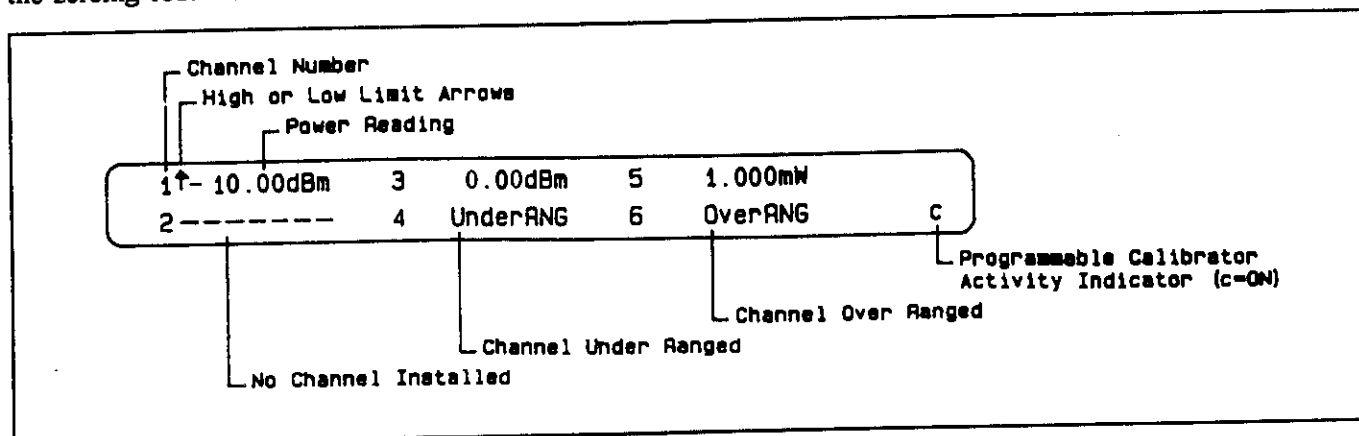

Figure 3-5. Multichannel Display

### 3-8. SUMMATION OPERATION.

#### NOTE

The summation operation can be considered a special mode of multichannel operation since several channels are making simultaneous measurements. Most of the operating procedures for multichannel operation are applicable to summation operation. Summation operation is configured by setting up the channels one at a time in single channel operation (entering sensor data, etc.), then verifying proper operation of all channels in multichannel operation and then entering the summation equation, as shown in the steps below.

1. Refer to Paragraph 3-7, Multi-Channel Operation and perform steps 1 through 10. Refer to Figure 3-6 for a Summation Operation Display (Sample).

2. Enter the summation equation. Press SHIFT, CHAN  $\Sigma$ , and the equation, in the form  $a+b+c+d+e+f$  etc. where a, b, c, d, e, and f correspond to channels 1 through 6, ENTER.

Example:

Press SHIFT, CHAN  $\Sigma$ , 1, +, 2, -, 4, ENTER. The total can be displayed in either watts or dBm, (in watts the equation becomes a ratio, that is, powers are divided and multiplied).

3. To perform the summation equation press  $\Sigma$  ENA. The display will indicate the resulting dB difference or power ratio, along with the equation.

4. Press dBm or dBr to display the difference in dB.

5. Press WATTS to display the power ratio. Ratio is expressed in percent from 99.999% to .0001%.

6. To return to multichannel operation Press MULTI.

7. The summation in the linear mode (watts) can also be displayed as total power. Refer to special function 11 in Section 3 under SPCL key.

### 3-9. 75 OHM SENSOR CALIBRATION.

When a 51012 or other 75 ohm sensor is used with the 4300, the following procedure must be used for calibration, either with the fixed 50 MHz 0 dBm calibrator or with the adjustable 30 MHz calibrator.

The calibrators have 50 ohm outputs. There are three methods to handle the mismatch:

1. With a 50 to 75 ohm transformer. With this method there is a fixed loss which must be measured (generally this loss is about .05 to 0.1 dB), and entered as a correction factor as shown below. Mismatch errors are at a minimum using this method.

2. With a minimum loss resistive attenuator (50 to 75 ohms). With this method there is a fixed loss of 1.76 dB and the VSWR is held to a low value. The loss must be entered as a correction factor as shown below. This method is generally not as accurate as the other two methods unless the attenuation of the pad is known exactly.

3. With a straight through 50 to 75 ohm adapter, Boonton P/N 950006, which is a mechanical adapter only (no resistors). The 75 ohm type N connector has a different diameter center pin than the 50 ohm unit. With this method, the loss due to mismatch is 0.17 dB and it must be entered as a correction factor as shown below. There can be considerable mismatch errors using this method.

### 3-10. CORRECTION FACTOR ENTRY (75 OHM SENSORS).

Enter the loss as a positive number in dB REF (use SET REF key) before calibration. Then when taking measurements, disable the dB REF by setting the units to dBm, or by setting dB REF to zero, or both. The instrument will be calibrated taking the reference into account; it is not lost. Now the dB REF function can be used normally. Note: When the 30 MHz adjustable output calibrator is used in the 4300, the instrument automatically sets dB CF to zero during

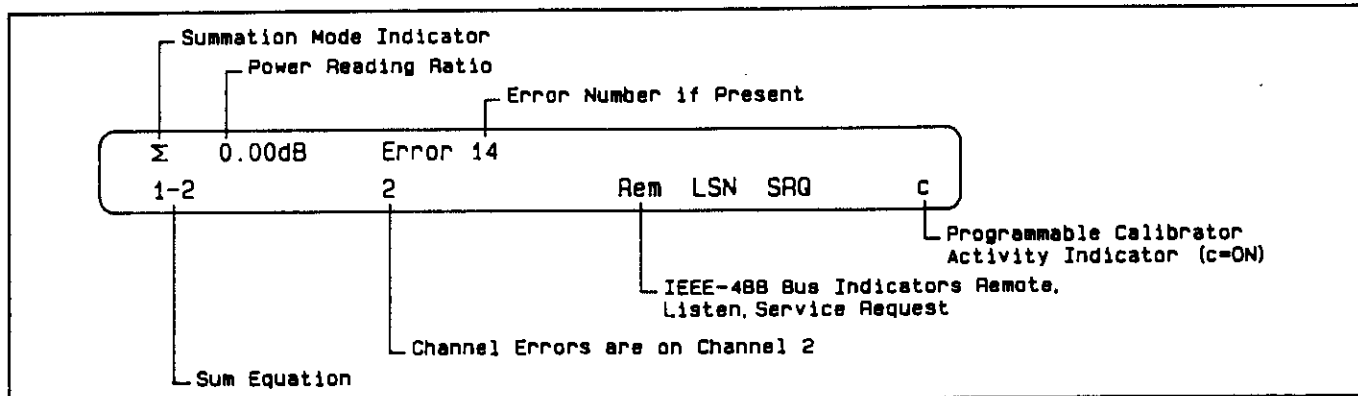

Figure 3-6. Summation Display.

the autocalibration cycle, therefore dB CF should never be used to enter this correction factor. Fixed calibration at (0 or -20 dBm), however, does incorporate the dB CF to allow the calibration of millimeter wave sensors at levels that are not precisely known. Therefore, when using fixed calibration, the correction factor may be entered into either dB CF or dB REF. The limit on entries for either parameter is  $\pm 3$  dB.

### 3-11. SPECIFIC KEY OPERATION.

Each of the keys is described in detail below.

**3-12. ESCAPE Key.** Pulls the 4300 out of any of the menu-driven sequences (sensor entry, summation, equation, etc.) and all implied shifts and prompts. Clears the right-hand data entry field of the display. Returns the instrument to measurement mode. Serves as a general purpose clear which can be used before initiating any function. Also performs the local function.

**3-13. SHIFT Key.** Illuminates a lower case "x" located on the lower right hand side of the display, to indicate the shifted function, and sets the 4300 up to accept the shifted panel marking functions above particular keys. However, numbers are not entered using SHIFT since they always follow a prompt, which builds in, or implies a SHIFT. For example, to set range 5, press SHIFT, RANGE SET, 5, ENTER. The shift key need not be pressed before the "5" because the RANGE SET key implies the shift. (CLR, ., +, -, and  $\rightarrow$  are also implied shift keys.)

**3-14. 0 through 9 Keys.** Numeric entry keys. The SHIFT key need not be pressed first.

**3-15. =, -, and, • Keys.** Used for numeric sign and decimal point entry.

**3-16.  $\rightarrow$  (BACKSPACE) Key.** Used in numeric entry routines to "erase" inadvertent panel entries

| Operation                  | Press         | Display Shows            |
|----------------------------|---------------|--------------------------|
| Backspaces numeric entries | $\rightarrow$ | (Any wrong entry erased) |

**3-17. ENTER Key.** Completes a numeric entry and causes the instrument to process the entered number.

**3-18. SCROLL Key.** The SCROLL key advances the menu items or scrolls through sensor data types as applicable. Scroll is an implied shift; that is, when scrolling is allowed, the SHIFT/SCROLL key will automatically become a scroll key. SCROLL is used in the sensor entry and view modes, and in some of the Special and Test modes.

**3-19. (LOCAL) Key.** Returns the instrument to local (front panel) Control mode. Can be disabled by the local lockout command over the GPIB. Also performs the ESCAPE function. The parenthesis around the LOCAL on the (LOCAL) key signifies that when the (LOCAL) key is pressed, the shift is implied, and the SHIFT key does not have to be pressed.

**3-20. SRQ Key.** In the appropriate bus modes, will generate a service request (SRQ) for manual triggering of GPIB measurements. It is enabled by setting the SRQ mask byte. Refer to the GPIB Paragraph.

**3-21. ADDR Key.** Prompts the user for the GPIB address. The limits are 0 - 31.

| Operation                        | Press      | Display Shows  |
|----------------------------------|------------|----------------|
| Views or changes the bus address | ADDR       | Current number |
|                                  | m<br>ENTER | Desired number |

**3-22. ZERO Key.** Zeros all displayed channels. If the power is above a preset limit on a particular channel (roughly a full scale signal on range 0), the channel will not zero, and will instead display an error message. A 2 second delay is provided after the zero key is depressed to allow the sensor to decay. However, more time may be necessary at low levels. Refer to Section 4. Zeroing takes from 8 to 20 seconds depending on the filter selected. In Multichannel mode, if it is desired to zero just one channel, the operator can put the unit into single channel and press ZERO. Multichannel mode may be recalled while that channel is still zeroing. The chart recorder output can be set up as a TTL signal that is active while the 4300 is zeroing, for purposes of disabling the source. Refer to Section 4.

| Operation                     | Press | Display Shows                              |
|-------------------------------|-------|--------------------------------------------|
| Zero (single or multichannel) | ZERO  | Checking, Settling, Zeroing, (in sequence) |

**3-23. TEST Key.** Used to select and execute one of the Model 4300's built-in diagnostic tests.

| Operation       | Press      | Display Shows     |
|-----------------|------------|-------------------|
| Run self test m | TEST       | Select Test       |
|                 | m<br>ENTER | (results of test) |

To display the available self-test choices, press TEST followed by (SCROLL). The test menu will be displayed, which shows the available self-tests, along with the prompt to enter the test number. The available tests are as follows:

1. Keyboard Test - displays the scan code of each key when it is pressed.
2. Display Test - displays all pixels, followed by a full character set.
3. Memory Test - checks internal memory for errors.
4. DIP Switch Test - displays settings of configuration DIP switches.
5. GPIB Bus Test - checks and exercises the GPIB.
6. Software Revision - displays the software title and version number in ROM.
7. Battery Test - checks the backup battery state of charge.

**3-24. SPCL Key.** Prompts the user for a number (1-11) and goes into Special modes as shown in Table 3-5.

To display the Special Functions Menu, press SPCL, then (SCROLL). Eleven functions are available, therefore; each time the (SCROLL) key is pressed, a Special Function will be displayed. Enter the Special Function number to select the function, then press the (SCROLL) key again to display the Special options if available.

**3-25. FILTER Key.** Prompts the user for the digital filter length in milliseconds from 20 to 20,000 mS in 20 mS increments. Uneven increments are accepted and rounded off to the nearest 20 ms. Entering "0" will cause the 4300 to use default filter lengths which have been chosen to optimize speed and accuracy in each range. Refer to the INSTR RECALL key description for the default values. The default values are a function of range and input channel type (universal or thermal). The filter key also calls up the current length on the display, whether internally generated or user set. The filter entries apply to all displayed channels, but in Multichannel mode, the recalled number on the display will be blank if the filter lengths are not equal on all channels. If the default filters are applied to all channels, but the channels are on different ranges, the display will also be blank. Refer to Section 4, Making Measurements for more detailed filtering information.

| Operation Press      | Display Shows               |
|----------------------|-----------------------------|
| Views/changes filter | FILTER Present filter in mS |
|                      | Desired time in mS          |
|                      | Desired filter in mS        |
|                      | ENTER                       |

**TABLE 3-5. SPECIAL FUNCTIONS**

| SPECIAL # |                                                                           |                                                                                                                                                                                                                                                                                                                                                                                                                                                                               |                                                                                            |
|-----------|---------------------------------------------------------------------------|-------------------------------------------------------------------------------------------------------------------------------------------------------------------------------------------------------------------------------------------------------------------------------------------------------------------------------------------------------------------------------------------------------------------------------------------------------------------------------|--------------------------------------------------------------------------------------------|
| 1         | Trigger Mode Setup<br>Refer to Section 4 for Triggered Operation.         | 0 — Free Run Mode<br>1 — Free Run Filtered Mode<br>2 — Free Run Settled Mode<br>3 — Trigger Filtered Mode<br>4 — Trigger Settled Mode<br>5 — Trigger Delay (130 ms default)                                                                                                                                                                                                                                                                                                   | (Numbers 0 through 4 activate a Trigger Mode: Number 5 prompts the Operator for a number.) |
| 2         | Recorder Output scaling. Refer to Section 4 for Chart Recorder Operation. | 0 — Sets bottom (0V)<br>1 — Sets top (10V)<br>2 — Summation assignment<br>3 — Recorder off<br>4 — Zero indicator<br>5 — HI/LO limit indicator<br>6 — Raw value<br>7 — Measurement mode<br>8 — Recorder DC level                                                                                                                                                                                                                                                               |                                                                                            |
| 3         | DC Calibration Factor<br>Entry/Edit                                       | The DC calibration data points are gain factors for the channel cards, one point for each of the 7 ranges and one additional point for A/D adjustment. This function allows the user to view this data and change it if necessary. The data being worked with is that on the currently selected channel card. Refer to Section 6. This data can be protected to prevent alteration from the front panel by the use of position 2 on the internal Bit switch. See Table 6-2-2. |                                                                                            |



TABLE 3-5. SPECIAL FUNCTIONS (Con't)

| SPECIAL # |                                           |                                                                                                                                                                                                                                                                                                                                                                                                                                                                                                                                                                                                                                                                                                                                                                                                                                               |
|-----------|-------------------------------------------|-----------------------------------------------------------------------------------------------------------------------------------------------------------------------------------------------------------------------------------------------------------------------------------------------------------------------------------------------------------------------------------------------------------------------------------------------------------------------------------------------------------------------------------------------------------------------------------------------------------------------------------------------------------------------------------------------------------------------------------------------------------------------------------------------------------------------------------------------|
| 4         | DC Calibration<br>Factor Calculation      | The DC calibration data points are gain factors for the channel cards, one point for each of the 7 ranges and one additional point for A/D adjustment. This special function allows an automatic computation of the gain factors when calibrating. Refer to the front panel by the use of position 2 on the internal Bit switch. See Table 6-202.                                                                                                                                                                                                                                                                                                                                                                                                                                                                                             |
| 5         | AC 14-Point<br>Calibration                | This function generates linearity data, referred to as 14-point upscale/downscale data, for coaxial sensors that are to be used on a Boonton 4200 Power Meter. There are seven upscale points (one per range) and seven downscale points. To use this function, place the 4300 in the single channel mode and connect the sensor to the programmable 30 MHz Calibrator. Assign a sensor number (1-20) that is not currently used and enter the sensor type, then press SPCL, 5, ENTER. When the generation of data is complete, the 14-point data may be extracted by pressing the SENSOR DATA ENTRY key. Note: The control board bit switch #2 must be in the ON position to accept the AC 14-point calibration. Do not use the 14-point calibration routine (SPCL5) for the following sensors: 51075, 51078, 51200, 51201, 51300, or 51301. |
| 6         | Recalibrate<br>Programmable<br>Calibrator | The programmable calibrator can be field calibrated. Refer to Section 6. This data can be protected to prevent alteration from the front panel by the use of position 2 on the internal Bit switch. See Table 6-202.                                                                                                                                                                                                                                                                                                                                                                                                                                                                                                                                                                                                                          |
| 7         | Bar Graph Toggle<br>ON/OFF                | The bar graph is a 40 division power level indicator that appears only in single channel mode when activated. It works as a linear graph when the channel is in watts and logarithmic when the channel is in dBm or dBr. The scale of the graph is programmable and uses the chart recorder operating parameters as its scale factor. For the bar graph to work properly, the chart recorder should be in the measurement mode (7). To set the scale, see chart recorder operation in Section 4.                                                                                                                                                                                                                                                                                                                                              |
| 8         | Raw Value Mode                            | The value displayed in this mode is the A/D level from the input channel representing the digitized sensor voltage before any shaping or adjustments are made to it. Its range is 0 to 8192 over each of the seven ranges. The raw value mode is used in diagnostics and calibration routines. The raw value mode is disabled by pressing dBm, dBr, or Watts.                                                                                                                                                                                                                                                                                                                                                                                                                                                                                 |
| 9         | Trigger                                   | This command allows the operator to perform a trigger from the front panel of the instrument. This command is active only when the instrument is already in one of the trigger measurement modes.                                                                                                                                                                                                                                                                                                                                                                                                                                                                                                                                                                                                                                             |
| 10        | Measurement Status                        | The measurement status command activates a temporary display which shows the current measurement mode, if fixed point cal is active, and if multipoint cal is active. It indicates the status of the last single channel that was selected.                                                                                                                                                                                                                                                                                                                                                                                                                                                                                                                                                                                                   |
| 11        | Linear Summation %/Power                  | This special, when selected, toggles between the ratio (%) and the total power display modes when the summation channel is enabled in the linear (Watts) mode. Ratio is the power-on default setting. This setting is preserved in the instrument's store and recall functions.                                                                                                                                                                                                                                                                                                                                                                                                                                                                                                                                                               |

**NOTE 1**

This function affects all displayed channels whether in single or multichannel operation. Changing from multi-channel to single channel does not affect the status of this parameter on any channel. For example, in multichannel, to set this parameter on any one channel, go to single channel, set it, and go back to multichannel. The channel parameters are: range mode, hold or auto, frequency, filter length, dB-cal factor, high and low limits, duty cycle, peak hold enabled, chart recorder scaling, units (Watts, dBm, dBr) dB reference, trigger mode and trigger delay.

**3-26. FREQ Key.** When the FREQ key is pressed, the display will prompt the user for frequency. Frequency is entered in GHz from .01 to 110 GHz. The 4300 then looks up the appropriate high frequency cal factor for each sensor that has been assigned, and linearly interpolates between points as required. In Multichannel mode if a frequency outside the range of any sensor is entered, an error message is displayed showing the affected channel(s). If the sensor frequency ranges do not overlap, entering a frequency in Multichannel mode is not allowed. Error messages will not be generated for uninstalled channels. Refer to Note 1 above.

**3-27. dB CF Key.** When it is desired to enter the high frequency cal point directly rather than retrieve/interpolate it from the sensor data, this key may be used. Entry is limited to  $\pm 3$  dB in .01 dB steps. Also, this key can be used to recall the frequency cal factor that has been retrieved and interpolated from the sensor tables. Refer to Notes 1 and 2.

**NOTE 2**

dB CF will be temporarily set to zero during autocalibrating with the programmable 30 MHz calibrator.

| Operation                       | Press       | Display Shows                 |
|---------------------------------|-------------|-------------------------------|
| View/change calibration factors | dB CF       | Present value of offset in dB |
|                                 | Value in dB | Desired value in dB           |
|                                 | ENTER       |                               |

**3-28. DTY CY Key.** Prompts the user for the duty cycle in % from .0001% to 100%. Puts the displayed channels in pulse power mode. Pulse power is calculated by the 4300 by dividing the measured average power by the entered duty cycle, and, if a diode detector is used, scaling by a correction factor based on the diode detector's transfer characteristics. In Single Channel mode, both peak and average powers are shown along with the duty cycle and additional messages for more information. In Multichannel mode, only the pulse

powers are displayed. The high and low limits, if set, apply to the average power. The dB REF and dB LOAD keys still operate normally. The Pulse Power mode is disabled by pressing DSBL. Refer to Section 4 for detailed information regarding pulse power measurements. Refer to Note 1 in section 3-26 for information regarding multichannel operation.

| Operation                            | Press  | Display Shows                                                                                                                                                                   |
|--------------------------------------|--------|---------------------------------------------------------------------------------------------------------------------------------------------------------------------------------|
| Pulse power calculation (duty cycle) | DTY CY |                                                                                                                                                                                 |
|                                      | mm.mmm |                                                                                                                                                                                 |
|                                      | ENTER  | Duty cycle, average, and pulse power in watts, dBm, or dBr, and the region of diode sensors (square-law, transition, or peak). In multichannel only the pulse powers are shown. |

**3-29. DSBL Key.** Disables the pulse power mode. Refer to Note 1 above.

| Operation                 | Press | Display Shows    |
|---------------------------|-------|------------------|
| Disables pulse power mode | DSBL  | Average power(s) |

**3-30. LO LIM Key.** Used for go/no-go tests. Prompts the user for a low limit in dBm from -199 to +199 dBm. When entered, if the measured power is below the limit, the display will indicate a flashing down arrow to the left of the power. Although the limit entries must be entered in dBm, the limits still work in dBr, dBm, and watt modes. The limit entries affect all the displayed channels, and operate on the displayed value (i.e., in dBr mode, the reference is taken into account). The out of limit condition can be outputted on the chart recorder as a level, by pressing SPCL, 2, ENTER, 5, ENTER. Refer to Section 4, Chart Recorder Operation. Refer to Note 1 in section 3-26 for information regarding multichannel operation.

| Operation                    | Press                | Display Shows          |
|------------------------------|----------------------|------------------------|
| Sets the high limit (in dBm) | HI LIM               | High limit value in dB |
|                              | Desired value in dBm | Desired value in dB    |
|                              | ENTER                |                        |

**3-31. HI LIM Key.** Similar to LO LIMIT. The high limit is -199 to +199 dBm. When the high limit is exceeded, a flashing up arrow is indicated. The HI LIMIT entry must be larger than the LO LIMIT entry. Refer to Note 1 in section 3-26 for information regarding multi-channel operation.

| Operation                    | Press                | Display Shows           |
|------------------------------|----------------------|-------------------------|
| Sets the high limit (in dBm) | HI LIM               | High limit value in dBm |
|                              | Desired value in dBm | Desired value in dBm    |
|                              | ENTER                |                         |

**3-32. PK HLD Key.** When this function is enabled, each measurement is compared to the previous reading and the highest of the two is held and displayed. The effective sampling time is 25 mS/channel typically (150 mS for 6 channels). Resetting is accomplished by pressing PK HLD again. To disable press PK off. Applies to all displayed channels. Not related to pulse power mode. Refer to Note 1 in section 3-25 for information regarding multichannel operation.

| Operation | Press   | Display Shows                                             |
|-----------|---------|-----------------------------------------------------------|
| Peak hold | PK HOLD | Peak power in dBm, dBr or watts on all displayed channels |

**3-33. PK OFF Key.** Disables the peak hold functions. Refer to Note 1 in section 3-25 for information regarding multichannel operation.

| Operation         | Press  | Display Shows    |
|-------------------|--------|------------------|
| Peak hold disable | PK OFF | Average power(s) |

**3-34. CHAN  $\Sigma$  Key.** Prompts the user for the channel summation equation. Entry is in the form of an algebraic equation, for example 1-3+6 ENTER (dB mode). In watts mode, the +/- keys are still used but are displayed as multiply/divide signs. The (CLR) and backspace ( $\rightarrow$ ) keys operate in the same manner as for numeric entry. See  $\Sigma$  ENA key.

| Operation                    | Press                                          | Display Shows         |
|------------------------------|------------------------------------------------|-----------------------|
| Enter the summation equation | SHIFT, CHAN $\Sigma$<br>1, -, 3, +, 6<br>ENTER | Sum $\Sigma$ equation |

**3-35.  $\Sigma$  ENA Key.** Places the Model 4300 in the Summation Channel mode. Displays the summation equation, (up to 6 channels), for example 1+3-4 (in dB mode), and the result in dB. In power mode, the +/- signs are displayed as divide/multiply and the result is a ratio. Ratio is shown in % from 0.1% to 99,999% (1000:1 or 1:1000). If the total power option has been enabled by special function 11, the summation is displayed as watts in the power mode and the operators are +/- . A general purpose error message is generated if a channel is over/under range, has exceeded HI/LO limits, etc. The message indicates which channel has the problem. The CHAN, MULTI, and  $\Sigma$  ENA keys are mutually exclusive.

| Operation                  | Press        | Display Shows                                                                       |
|----------------------------|--------------|-------------------------------------------------------------------------------------|
| Enables the summation mode | $\Sigma$ ENA | The summation equation and the sum or difference in watts or dB, or the ratio in %. |

**3-36. SET CH Key.** Prompts the user for a channel (1-6) to be viewed.

| Operation                  | Press                              | Display Shows                                  |
|----------------------------|------------------------------------|------------------------------------------------|
| Selects a specific channel | SHIFT, SET CH<br>n (1-6),<br>ENTER | Present channel number<br><br>Selected channel |

**3-37. CHAN Key.** Puts the unit in Single Channel mode on the last channel that was selected. The CHAN, MULTI and  $\Sigma$  ENA are mutually exclusive.

| Operation                          | Press | Display Shows                    |
|------------------------------------|-------|----------------------------------|
| Displays the last channel selected | CHAN  | The last single channel selected |

**3-38. MULTI Key.** Places the unit in Multichannel mode. Channel slots that are not filled are shown with dashes on the display. Channel parameters that are entered in this mode (such as frequency, filter, etc.) are applied to all channels. Channel parameters that are called up on the display will only be shown if the parameter is identical for all 6 channels. The CHAN, MULTI, and  $\Sigma$  ENA modes are mutually exclusive.

| Operation           | Press | Display Shows                             |
|---------------------|-------|-------------------------------------------|
| Displays 6 channels | MULTI | Power in watts, dBm or dBr for 6 channels |

**3-39. SENSOR DATA VIEW Key.** This key is used to provide a quick summary of any one of up to 20 stored sensors, showing type, serial number and to which channel it is assigned, if any. When pressed, the 4300 prompts the user for the sensor number (1-20). Pressing enter starts viewing the sensors beginning with this one. The SHIFT/(SCROLL) key is used to advance to the next sensor and the ESCAPE key is used to exit back to the main level (measurement mode).

| Operation                                     | Press                      | Display Shows                                                                     |
|-----------------------------------------------|----------------------------|-----------------------------------------------------------------------------------|
| Views sensor S/N, type and channel assignment | SHIFT<br>SENSOR-<br>VIEW 3 |                                                                                   |
|                                               | ENTER                      | Sensor # (3 for this example), type, serial #, channel(s) that it is assigned to. |
|                                               | SCROLL                     | Sensor # (4 for this example), type, serial #, channel(s) that it is assigned to  |
|                                               | ESCAPE                     |                                                                                   |

**3-40. SENSOR DATA ENTRY Key.** Initiates the routine for entering sensor calibration data, sensor type and serial number into the sensor bank (1-20 sensors). Refer to Section 4 for a more detailed explanation of calibration data. Pressing this key prompts the user for a sensor number (1-20) for which calibration data is to be modified. (The default number that is displayed is the sensor currently assigned to the selected channel.)

**NOTE**

To unprotect sensor data, set the rear panel switch positions to closed and set the internal switch on the control board (position 3) to ON. See Figure 6-201. The switches may be left in the unprotected mode if desired.

Section 3  
Operation

Once the sensor is selected, a sub-mode is entered which allows data to be examined or altered. There are 6 types of data that can be entered as listed below. The 4300 prompts the user for each type of data. Any point in data entry, the ESCAPE key will clear the sub-mode and exit to the measurement mode. Data entered up to that point will be retained. The (SCROLL) key can be used to advance to the beginning of the next section without having to pass through each entry. The RECALL key can be used to back up to the last entry in a particular section.

1. **Sensor Type.** The first data to be entered is the sensor type, which is a 5 digit number. A list of available sensor types and a cross reference to Boonton 4200 sensor types is shown in Table 3-6 and may also be viewed in menu form by pressing the (SCROLL) key.

**TABLE 3-6.**  
**4200/4300 SENSOR CROSS REFERENCING**

| 4200          | 4300  |
|---------------|-------|
| 4200-4A       | 51010 |
| 4200-4B       | 51011 |
| 4200-4C       | 51012 |
| 4200-4E       | 51013 |
| 4200-4G       | 51051 |
|               | 51071 |
|               | 51072 |
|               | 51075 |
| 4200-5B       | 51014 |
| 4200-5E       | 51015 |
| 4200-6E       | 51033 |
|               | 51078 |
| 4200-7E       | 51016 |
| 4200-8E       | 51017 |
| 4200-9E       | 51100 |
|               | 51101 |
|               | 51102 |
|               | 51200 |
|               | 51201 |
|               | 51300 |
|               | 51301 |
| 4200-4K       | 51035 |
| 4200-4KA      | 51036 |
| 4200-4Q       | 51037 |
| 4200-4U       | 51045 |
| 4200-4V       | 51046 |
| 4200-4W       | 51047 |
| 51972-WRD-180 |       |
| 51972         |       |

2. **Serial Number.** The second data to be entered is the sensor serial number, which is located on the sensor label. Enter the number from 0 to 999,999, and press ENTER.

3. **Upscale Calibration Factors.** Supplied with each diode sensor is a group of 7 upscale calibration factors for thermal sensors, one for each range. Alternatively, these numbers can be generated with the "14-point calibration data routine". These calibration factors are used to linearize the sensor. (If the 30 MHz autocalibration cycle is used, upscale and downscale points do not need to be entered.) Refer to Section 4 for information on the use of calibration factors. The factors are entered as shown below. The valid range of numbers is from 4200 to 5800, with 5000 being the nominal calibration (default value). The 4300 prompts the user for an upscale number on each range and then proceeds to the downscale data points.

**NOTE**

If it is desired to skip the upscale and downscale points and go directly to entry of the frequency calibration points, press the (SCROLL) key.

4. **Downscale Calibration Factors.** Also supplied with each sensor is a group of downscale points which are entered with the same procedure as the upscale data points. The valid range is from -200 to +200.

5. **Frequency Calibration Points.** Supplied with each sensor is a list of high frequency calibration points (also referred to as dB Cal Factor points), which consists of a frequency and correction factor for each point. This information must be entered in sequence beginning with the lowest frequency. The number of the calibration point (table entry) is displayed as "TBL#" during this entry procedure. When all of the points have been entered, press ESCAPE to return the 4300 to its normal operating mode.

**NOTE**

Sensors 1 through 6 allow up to 80 cal points, while entries 7 through 20 allow up to 35 points.

a. The first part of the pair is frequency with the units in GHz. The range of accepted values is from 0.0 to 110 GHz in .01 GHz increments. Sensors are generally supplied with their first calibration point at 1 GHz. If frequencies below the first point are to be used in operation, a starting point should be entered at 0 GHz, 0 dB CF.

b. The second part of the pair is the cal factor in dB. The range of acceptable correction factors is from +3 to -3 with two decimal places (.01 dB resolution).

c. Example: The procedure below shows the entire sensor entry procedure.

| Operation                                                    | Press                       | Display Shows |
|--------------------------------------------------------------|-----------------------------|---------------|
| Enter sensor data for one sensor into the sensor bank (1-20) | SENSOR-ENTRY<br>18<br>ENTER | Enter type    |
|                                                              | SCROLL<br>SCROLL            | 51013         |
|                                                              | 51013                       |               |

| Operation                                                                                                                                                                                                                                                                                                                                                                                                                                                                                                                                                                                                                                               | Press                       | Display Shows    |
|---------------------------------------------------------------------------------------------------------------------------------------------------------------------------------------------------------------------------------------------------------------------------------------------------------------------------------------------------------------------------------------------------------------------------------------------------------------------------------------------------------------------------------------------------------------------------------------------------------------------------------------------------------|-----------------------------|------------------|
| <p><b>NOTE:</b> This example enters a type 51013 sensor, S/N 12345, into location 18. The upscale calibration factors are 5204, etc. The downscale factors are -17 etc. A cal point of 1.20 dB at 2 GHz has been entered and also a point of 1.4 dB at 3.5 GHz. When the ENTER key is pressed, the display advances to the next frequency or cal factor, recalling the previous data entry, which is zero for an unloaded sensor. The serial number, upscale or downscale points, or frequency cal points can be bypassed by pressing SCROLL.</p> <p>After entering the data, the sensor must be assigned to a channel. Refer to SENSOR ASSIGN key.</p> | ENTER                       | Serial #         |
|                                                                                                                                                                                                                                                                                                                                                                                                                                                                                                                                                                                                                                                         | 12345                       | Upscale, RNG 0   |
|                                                                                                                                                                                                                                                                                                                                                                                                                                                                                                                                                                                                                                                         | ENTER                       |                  |
|                                                                                                                                                                                                                                                                                                                                                                                                                                                                                                                                                                                                                                                         | 5024                        | Upscale, RNG 1   |
|                                                                                                                                                                                                                                                                                                                                                                                                                                                                                                                                                                                                                                                         | ENTER                       |                  |
|                                                                                                                                                                                                                                                                                                                                                                                                                                                                                                                                                                                                                                                         | 5024                        | Upscale, RNG 2   |
|                                                                                                                                                                                                                                                                                                                                                                                                                                                                                                                                                                                                                                                         | ENTER                       |                  |
|                                                                                                                                                                                                                                                                                                                                                                                                                                                                                                                                                                                                                                                         | 5103                        | Upscale, RNG 3   |
|                                                                                                                                                                                                                                                                                                                                                                                                                                                                                                                                                                                                                                                         | ENTER                       |                  |
|                                                                                                                                                                                                                                                                                                                                                                                                                                                                                                                                                                                                                                                         | .                           | .                |
|                                                                                                                                                                                                                                                                                                                                                                                                                                                                                                                                                                                                                                                         | .                           | .                |
|                                                                                                                                                                                                                                                                                                                                                                                                                                                                                                                                                                                                                                                         | .                           | .                |
|                                                                                                                                                                                                                                                                                                                                                                                                                                                                                                                                                                                                                                                         | 4984                        | Downscale, RNG 0 |
|                                                                                                                                                                                                                                                                                                                                                                                                                                                                                                                                                                                                                                                         | ENTER                       |                  |
|                                                                                                                                                                                                                                                                                                                                                                                                                                                                                                                                                                                                                                                         | -17                         | Downscale, RNG 1 |
| ENTER                                                                                                                                                                                                                                                                                                                                                                                                                                                                                                                                                                                                                                                   |                             |                  |
| .                                                                                                                                                                                                                                                                                                                                                                                                                                                                                                                                                                                                                                                       | .                           |                  |
| .                                                                                                                                                                                                                                                                                                                                                                                                                                                                                                                                                                                                                                                       | .                           |                  |
| .                                                                                                                                                                                                                                                                                                                                                                                                                                                                                                                                                                                                                                                       | .                           |                  |
| -8                                                                                                                                                                                                                                                                                                                                                                                                                                                                                                                                                                                                                                                      | Downscale, RNG 6            |                  |
| ENTER                                                                                                                                                                                                                                                                                                                                                                                                                                                                                                                                                                                                                                                   |                             |                  |
| -6                                                                                                                                                                                                                                                                                                                                                                                                                                                                                                                                                                                                                                                      | FREQ 0.00 GHz, TBL #00      |                  |
| ENTER                                                                                                                                                                                                                                                                                                                                                                                                                                                                                                                                                                                                                                                   |                             |                  |
| 2                                                                                                                                                                                                                                                                                                                                                                                                                                                                                                                                                                                                                                                       | CAL FACTOR 0.00<br>TBL #00  |                  |
| ENTER                                                                                                                                                                                                                                                                                                                                                                                                                                                                                                                                                                                                                                                   |                             |                  |
| 1.22                                                                                                                                                                                                                                                                                                                                                                                                                                                                                                                                                                                                                                                    | FREQ 0.00 GHz, TBL #01      |                  |
| ENTER                                                                                                                                                                                                                                                                                                                                                                                                                                                                                                                                                                                                                                                   |                             |                  |
| RECALL                                                                                                                                                                                                                                                                                                                                                                                                                                                                                                                                                                                                                                                  | CAL FACTOR 1.22,<br>TBL #00 |                  |
| ENTER                                                                                                                                                                                                                                                                                                                                                                                                                                                                                                                                                                                                                                                   |                             |                  |
| 1.20                                                                                                                                                                                                                                                                                                                                                                                                                                                                                                                                                                                                                                                    | FREQ 0.00 GHz, TBL #01      |                  |
| ENTER                                                                                                                                                                                                                                                                                                                                                                                                                                                                                                                                                                                                                                                   |                             |                  |
| 3.50                                                                                                                                                                                                                                                                                                                                                                                                                                                                                                                                                                                                                                                    | CAL FACTOR 0.00,<br>TBL #01 |                  |
| ENTER                                                                                                                                                                                                                                                                                                                                                                                                                                                                                                                                                                                                                                                   |                             |                  |
| 1.40                                                                                                                                                                                                                                                                                                                                                                                                                                                                                                                                                                                                                                                    | FREQ 0.00 GHz, TBL #02      |                  |
| ENTER                                                                                                                                                                                                                                                                                                                                                                                                                                                                                                                                                                                                                                                   |                             |                  |
| ESCAPE                                                                                                                                                                                                                                                                                                                                                                                                                                                                                                                                                                                                                                                  | (measurement mode)          |                  |

**3-41. SENSOR S/N Key.** This key prompts the user for a 1 to 6 digit number which is used to search through all 20 sensor serial numbers for a match. If it is found, assigns that sensor to the currently selected channel. Used in place of the ASSIGN key. Must be used in the Single Channel Mode.

| Operation                                             | Press           | Display Shows                                                               |
|-------------------------------------------------------|-----------------|-----------------------------------------------------------------------------|
| <p>Assigns a sensor to a channel using sensor S/N</p> | SHIFT<br>SET CH |                                                                             |
|                                                       | 5               | Channel 5 power, etc.                                                       |
|                                                       | ENTER           |                                                                             |
|                                                       | SENSOR<br>S/N   |                                                                             |
|                                                       | 12045           | Channel 5 power, etc. The assignment can be verified by using the VIEW key. |
|                                                       | ENTER           |                                                                             |

**NOTE**

When a channel is reassigned to a new sensor, or when a sensor is reassigned to a channel that is already assigned to, the following actions occur:

1. The operating frequency and dB CF are set to 0.
2. The Autocalibration Data is erased (linearity data that was generated with the 30 MHz Programmable Calibrator).
3. The fixed point (0 dBm or -20 dBm) calibration data is erased.

**3-42.** This method of erasing calibration data (items 2 and 3 above) covers the case where a coaxial sensor is replaced with a mm wave sensor, which generally cannot be field calibrated. None of the sensor data stored in the sensor bank is lost (includes 14-point linearity data and high frequency cal factors).

**3-43. SENSOR ASSIGN Key.** This key is used to assign a sensor to the currently selected channel by sensor number (1-20). The 4300 must be in single channel mode. One sensor can be assigned to several channels, however, each channel can only have one sensor assigned to it at a time.

| Operation                            | Press            | Display Shows                                                             |
|--------------------------------------|------------------|---------------------------------------------------------------------------|
| <p>Assign sensor 16 to channel 2</p> | SHIFT<br>SET CH  |                                                                           |
|                                      | 2                | Channel 2 power, etc.                                                     |
|                                      | ENTER            |                                                                           |
|                                      | SENSOR<br>ASSIGN |                                                                           |
|                                      | 16               | Channel 2 power; the assignment can be verified by pressing the VIEW key. |
|                                      | ENTER            |                                                                           |

**3-44. dB REF SET Key.** Prompts the user for a reference level that all subsequent measurements are referred to. For example, if the dB reference is -20 dBm and the measurement power is -30 dBm and the display will indicate -10 dB. This function applies to all channels that are in dB mode. Disabling without deleting the reference is accomplished by pressing dBm or WATTS; the reference value will not be lost. Resetting the reference is accomplished by pressing dB REF SET, 0, ENTER. The dB CF function still operates normally and independently. The dB REF SET key implicitly activates the dB mode; dB mode does not need to be pressed after entering the reference. Refer to Note 1 above. The acceptable range of this value is -100 dBm to +100 dBm.

| Operation                  | Press                | Display Shows       |
|----------------------------|----------------------|---------------------|
| <p>Sets a dB reference</p> | SHIFT,<br>SET        | dBr (present value) |
|                            | Desired value in dBm | Desired value       |
|                            | ENTER                |                     |

Section 3  
Operation

**3-45. dB REF LOAD Key.** Takes the present measured value and uses it as a reference for all subsequent measurements. Pressing this key will set the display to 0.00 dBr for all valid power conditions. Disabling (but not deleting) the reference is accomplished by pressing dBm or WATTS. Resetting the reference is accomplished by pressing dB SET, 0, ENTER. The reference for each channel is independent. Refer to Note 1 above. This key also activates the dBr function; dBr does not need to be pressed after pressing dB REF LOAD.

| Operation Press       |                | Display Shows |
|-----------------------|----------------|---------------|
| Loads a dBr reference | SHIFT          | 0.00 dBr      |
|                       | dB REF<br>LOAD |               |

**3-46. dBr Key.** Puts all the displayed channels in dB reference mode. Uses the references that were loaded or set with dB REF LOAD or dB REF SET. Each channel has its own reference. Refer to Note 1 above.

| Operation             | Press | Display Shows |
|-----------------------|-------|---------------|
| Displays power in dBr | dBr   | Value in dBr  |

**3-47. dBm Key.** Puts all the displayed channels in the dBm mode, disabling the dB reference that was previously entered. The dB reference is still saved. Refer to Note 1 above.

| Operation      | Press | Display Shows |
|----------------|-------|---------------|
| Displays power | dBm   | Value in dBm  |

**3-48. WATTS Key.** Puts all the displayed channels in the watts mode (mW,  $\mu$ W, etc.). Any dBr reference that had been entered previously is not factored into the reading, however, it is still saved.

| Operation              | Press | Display Shows  |
|------------------------|-------|----------------|
| Display power in Watts | WATTS | Value in Watts |

**3-49. CALIBRATOR LIMIT Key.** Sets the upper power limit of the 30 MHz calibrator, for sensor protection purposes. The upper limit overrides subsequent level entries that are too high. When this key is pressed, the message CAL LIMIT and the present limit are displayed. The values that can be entered must be between -60 to +20 dBm, in 1 dB steps.

| Operation                      | Press                | Display Shows                   |
|--------------------------------|----------------------|---------------------------------|
| Sets calibrator maximum output | SHIFT                | Present calibrator limit in dBm |
|                                | LIMIT                | Desired calibrator limit in dBm |
|                                | Desired limit in dBm |                                 |
|                                | ENTER                |                                 |

**3-50. CALIBRATOR ON/OFF Key.** Toggles the 30 MHz calibrator output on and off. A lower case "c" is displayed in the lower right corner of the display when the calibrator is on.

| Operation                      | Press  | Display Shows               |
|--------------------------------|--------|-----------------------------|
| Turns the calibrator on or off | ON/OFF | c when ON<br>blank when OFF |

**3-51. CALIBRATOR AUTO CAL Key.** When this key is pressed, the 4300 initiates an automatic calibration routine as outlined below. The 4300 must be in single channel mode and the sensor connected to either the calibrator in the 4300 or an external calibrator at 0 or -20 dBm. The sensor must have a type entered (5 digit number) and it must be assigned to the channel to be calibrated. The automatic routine is as follows:

1. Zeros the channel.
2. Determines if a Programmable 30 MHz Calibrator is installed.
3. Determines if the sensor is connected to a fixed 0 dBm source, a -20 dBm source, or the programmable calibrator.
4. Based on 2 and 3 above, the 4300 will execute an automatic or fixed cal as described below. Press ENTER as prompted by the display to begin the calibration sequence.

**NOTE**

When a 75 ohm sensor is used with the calibrator, compensation must be made for the impedance mismatch. See paragraph 3-9, 75 OHM SENSOR CALIBRATION.

**3-52. AUTOCAL.** This routine steps the programmable calibrator through the entire sensor range in 1 to 6 dB steps (sensor and range dependent) up to +20 dBm. Each point is calibrated, accounting for sensor and input channel non-linearities, input channel DC gain error and offsets. The routine displays error conditions as appropriate. If a particular point will not calibrate, the routine exits, showing the power level in dBm at which the calibration failed. This routine serves as an excellent check of the overall measurement path. Zeroing the channel before executing an autocalibration is not necessary, although for maximum accuracy, power should be removed from the sensor for at least 30 seconds before autocalibrating. The autocal routine takes about 100 seconds. Calibrators mounted on the rear panel operate at a higher ambient temperature due to their close proximity to the heat sink and channel modules. Each channel installed will increase the temperature of the calibrator. If a rear-mounted calibrator is used, it is a good idea to allow extra time for the calibrator to stabilize - generally at least two minutes for each installed channel.

**3-53. FIXED CAL.** This routine calibrates at 0 or -20 dBm (determined automatically). Millimeter wave sensors are generally calibrated at -20 dBm. The channel should be zeroed first. The fixed calibration can be applied on top of the autocal calibration. For example, the autocalibration cycle can be executed to linearize the sensor, and then an overall correction can be applied by connecting the sensor to a fixed calibrator at 0 dBm. This may be useful when it is necessary to match the readings of the 4300 to other instruments in a measurement system. Calibrators mounted on the rear panel operate at a higher ambient temperature due to their close proximity to the heat sink and channel

| Operation                                     | Press                     | Display Shows    |
|-----------------------------------------------|---------------------------|------------------|
| Automatically calibrates a sensor and channel | SHIFT<br>AUTOCAL<br>ENTER | Autocal messages |

**3-54. CALIBRATOR LEVEL Key.** Displays the current level setting of the 30 MHz calibrator even if it is turned off. The range of values entered is between -60 and +20 dBm in 1 dB steps. When a value is entered into cal level, the new value is compared against the cal limit. If the new value is greater than the cal limit, an error is generated. The new level is activated when ENTER is pressed.

| Operation                        | Press                | Display Shows               |
|----------------------------------|----------------------|-----------------------------|
| Sets the calibrator output level | LEVEL                | Present Cal level in dBm    |
|                                  | Desired output level | Desired output level in dBm |
|                                  | ENTER                |                             |

**3-55. RANGE SET Key.** Prompts the user for the range (0-6 for diode sensors, 0-3 for thermal sensors), and applies it to all displayed channels. Refer to Note 1 above. Activates the range hold mode.

| Operation    | Press                                   | Display Shows |
|--------------|-----------------------------------------|---------------|
| Sets a range | SHIFT,<br>RANGE SET<br>n (0-6)<br>ENTER | RANGE n, HLD  |

**3-56. RANGE HOLD Key.** Locks each channel that is displayed into its present range. Ranges are roughly in 10 dB steps and are sensor type dependent. Disabled by going to autorange mode. Refer to Note 1 above.

| Operation          | Press | Display Shows                                |
|--------------------|-------|----------------------------------------------|
| Hold a given range | HOLD  | Adds HLD to presently displayed range number |

**3-57. RANGE AUTO Key.** Puts each channel that is displayed in autorange mode.

| Operation                      | Press | Display Shows |
|--------------------------------|-------|---------------|
| Auto ranges the input channels | AUTO  | Range         |

**3-58. INSTR STORE Key.** Prompts the user for a number 1-9 for which to store the full panel setup. A given SETUP contains:

- Mode (single, multi or summation channel)
- Operating frequency
- Calibrator level
- Recorder output scaling
- Measurement units (dBm, Watts, dBr)
- dB reference
- HI and LO limits
- Filter values
- Range mode (hold or auto)
- Range (in hold mode)
- Summation equation
- Duty cycle (if applicable)
- dB cal factor
- Peak hold enable
- Calibrator high limit
- Trigger delay
- Bar graph enable
- Trigger mode
- IEEE-488 bus talk mode
- Linear summation display mode

and the channel whose chart recorder output is assigned to summation result. The sensor data is in a separate memory section, and is not affected by instrument store or recall functions.

| Operation           | Press                                            | Display Shows        |
|---------------------|--------------------------------------------------|----------------------|
| Store a panel setup | SHIFT,<br>STORE<br>Storage number (1-9)<br>ENTER | Storage number (1-9) |

**3-59. INSTR RECALL Key.** Recalls one of nine previously stored panel setups, or the default instrument settings of the Model 4300. The calibrator always comes up in the off condition. Refer to the INSTR STORE key. The default state is shown below:

**3-60. RECALL 0 CONDITIONS.**

- Single channel, channel 1
- Auto range
- Calibrator Off, level at -60 dBm, max limit at +10 dBm
- dBm mode
- Duty cycle = 100% (disabled)
- Peak mode disabled
- Frequency = 30 MHz
- dB cal factor 0 dB
- dB reference = 0 dB
- High limit = +99.99 dBm
- Low limit = -99.99 dBm
- Chart recorder scaling from -60 dBm to +20 dBm

Section 3  
Operation

Default filters are as shown:

| Range | Universal Channels | Thermal Channels |
|-------|--------------------|------------------|
| 0     | 2.8 sec            | 4.8 sec          |
| 1     | 0.8                | 1.8              |
| 2     | 0.3                | 0.6              |
| 3     | .06                | 0.3              |
| 4     | .06                | -                |
| 5     | .06                | -                |
| 6     | .06                | -                |

Channel summation (ratio) set for Ch1-Ch2

Free run (untriggered) mode

Trigger Delay = 130 msec

Bar Graph disabled

IEEE-488 Talk Mode 0

Ratio (%) Linear Summation Mode

| Operation Press                        |                                     | Display Shows  |
|----------------------------------------|-------------------------------------|----------------|
| Recall a previously stored panel setup | SHIFT<br>RECALL<br>n (1-9)<br>ENTER | Recall number  |
| Recall the default panel setup         | SHIFT,<br>RECALL<br>0<br>ENTER      | Recall state 0 |

**3-61. SRQ Key.** Used to generate an SRQ (Service Request) signal over the GPIB. Refer to the following section on remote operation for more information on use of SRQ.

**3-100. REMOTE (GPIB) OPERATION.**

**3-101. INTRODUCTION.** Remote operation of the Model 4300 is accomplished through an IEEE-488 GPIB interface. IEEE-488 is a hardware standard which describes the communication and handshaking across an 8-bit parallel bus between a controller and up to 15 instruments.

**3-102.** The 4300 interfaces to the bus using a 9914A bus interface IC and tristate buffers. No DMA operations are supported. The table below lists the capabilities of the 4300.

|      |                    |                                               |
|------|--------------------|-----------------------------------------------|
| C0   | NO CONTROLLER      | Limited Capability                            |
| SH1  | SOURCE HANDSHAKE   | Complete Capability                           |
| AH1  | ACCEPTOR HANDSHAKE | Complete Capability                           |
| RL1  | REMOTE LOCAL       | Complete Capability                           |
| DC 1 | DEVICE CLEAR       | Complete Capability                           |
| DT1  | DEVICE TRIGGER     | Complete Capability                           |
| SR1  | SERVICE REQUEST    | Complete Capability                           |
| PP0  | PARALLEL POLL      | No Capability                                 |
| TE0  | EXTENDED TALKER    | No Capability                                 |
| T6   | BASIC TALKER       | Complete Capability, except for talker only   |
| LE0  | EXTENDED LISTENER  | No Capability                                 |
| LA   | BASIC LISTENER     | Complete Capability, except for listener only |

**3-103. LOCAL OPERATION.** Local operation indicates front panel control and operation of the instrument. The

local mode is the power on condition of the 4300, and remote mode becomes activated only when the instrument is addressed by

a remote controller. Once in remote mode, there are three ways to return the instrument to Local mode: 1) The controller issued a GTL command (Go To Local); 2) Power is removed from the instrument; or 3) The operator presses the ESCAPE/LOCAL key. This third method may be disabled by issuing a Local Lock Out command (LLO). The instrument will still talk and listen when addressed in Local mode.

**3-104. REMOTE OPERATION.** When in Remote mode all front panel keys are ignored except the ESCAPE (LOCAL) key. When in remote mode the message REM appears in the lower right corner of the display.

**3-105. SETTING THE BUS ADDRESS.** The GPIB listen/talk address (MLTA), can be set or altered only from the panel of the instrument by use of the ADRS key. Refer to the ADRS key in this section.

**3-106. TERMINATING CHARACTERS.** To inform the instrument that a complete message has been sent, the last character must be followed by a termination. The termination can be done either by asserting the EOI line on the bus or by sending an in-line terminating character, or both. The terminating character should be CR, LF, or CRLF. The selection of the terminating characters that are recognized is done by bit switch settings. For information on bit switch settings refer to Table 6-202 and Figure 6-201.

**3-107. BIT SWITCH SETTING (Rear Panel).** The Bit switch on the rear panel sets the 4300 up to accept line feeds or carriage returns as terminators, and sets miscellaneous functions. Refer to Table 6-202. The bus address is not controlled by this switch.

**3-108. LISTEN OPERATION.** The instrument may be addressed as a listener in both remote and local modes. When the listener state is set by the controller, the instrument will receive bytes over the bus and place them into its input buffer, and the LSN message will appear in the lower right hand corner of the display. For listen operation the input buffer is 512 characters long. Only one message can be put into the input buffer at a time. A second may not be sent until the instrument is finished processing the previous message.

**3-109. TALK OPERATION.** When the 4300 is requested to talk, it will respond according to how it has been set up. The setup is either through Talk modes or Talk Array commands. The Talk modes are associated with making



**TABLE 3-7. LISTEN PARAMETER COMMANDS**

| <b>KEY COMMANDS</b> |                         |                                       |
|---------------------|-------------------------|---------------------------------------|
| <b>MNEMONIC</b>     | <b>PARAMETER NUMBER</b> | <b>REFERENCE</b>                      |
| SETCH               | 1                       | "                                     |
| SETREF              | 2                       | "                                     |
| FREQ                | 3                       | "                                     |
| DBCF                | 4                       | "                                     |
| ASSIGN              | 5                       | "                                     |
| LOLIM               | 8                       | "                                     |
| HILIM               | 9                       | "                                     |
| SET                 | 11                      | See the key descriptions in Section 3 |
| RECALL              | 12                      | "                                     |
| STORE               | 13                      | "                                     |
| LIMIT               | 14                      | "                                     |
| LEVEL               | 15                      | "                                     |
| DTYCY               | 16                      | "                                     |
| S/N                 | 21                      | "                                     |
| FILTER              | 20                      | "                                     |

| <b>NON-KEY COMMANDS</b> |                         |                                                               |
|-------------------------|-------------------------|---------------------------------------------------------------|
| <b>MNEMONIC</b>         | <b>PARAMETER NUMBER</b> | <b>CORRESPONDS TO</b>                                         |
| TRDELAY                 | 17                      | SPECIAL 1, 5 (See SPECIAL Key)                                |
| RECSUM                  | 32                      | SPECIAL 2, 2 (See SPECIAL key)                                |
| RECTOP                  | 33                      | SPECIAL 2, 1 (See SPECIAL key)                                |
| RECBOT                  | 34                      | SPECIAL 2, 0 (See SPECIAL key)                                |
| RECLEVEL                | 35                      | SPECIAL 2, 8 (See SPECIAL key)                                |
| TALKMODE<br>(or TM)     | 22                      | No correspondence; sets talk mode;<br>See "Bus Only Commands" |
| SRQMASK                 | 23                      | No correspondence; sets SRQ mask;<br>See "Bus Only Commands"  |

measurements; the Talk Array commands are associated with downloading calibration data and instrument states. Refer to BUS Only Commands for setting up the Talk mode.

**3-110.** Only one instrument at a time can be addressed to talk on a GPIB, while many instruments can be addressed to listen simultaneously. When in the Talk mode, the 4300 displays the TLK message in the lower right corner of the display. The format for each talk message is different and is explained individually in the following sections.

**3-111. IEEE-488 COMMANDS SUPPORTED.** The 4300 supports the following standard IEEE-488 commands:

**1. Interface Clear Command.** The interface clear (IFC) command forces all devices on the bus to clear their interfaces, returns the instrument to local and returns the bus (not the instrument) to an initialized state, clearing the error conditions. This command can only be issued by the controller in charge. The 4300 responds by clearing the interface and executing the equivalent of the Escape command.

**2. Device Clear.** For the Model 4300, the device clear (DCL) command operates the same way as the IFC command, described above.

**3. Group Execute Trigger.** The Group Execute Trigger (GET) command allows the controller to issue a trigger to all instruments on the bus simultaneously. The GET command is most useful when the instrument is in a triggered measurement mode. The actual operation executed by the 4300 is the same as the software trigger command; refer to the SPECIAL function key and the section on triggered operation (Sections 3 and 4). When in free run mode, the instrument will save the current reading at the time of the GET command and return it at the time of the next "talk measure" mode. This is not the same as a triggered operation; this reading is based on the measurement history before the GET command. It is in essence a bus latch; the input channels are not triggered or affected.

**4. SRQ.** The Service Request allows an instrument to inform the controller that some special event has occurred. The instrument expects the controller to then perform a serial

**TABLE 3-8. LISTEN ACTION COMMANDS**

| <b>KEY COMMANDS</b>                                     |                                                               |
|---------------------------------------------------------|---------------------------------------------------------------|
| <b>MNEMONIC</b>                                         | <b>REFERENCE</b>                                              |
| ESCAPE (or ESC)                                         | "                                                             |
| DBR (or dBR)                                            | "                                                             |
| DBM (or dBm)                                            | "                                                             |
| WATTS                                                   | "                                                             |
| LOAD                                                    | "                                                             |
| ZERO                                                    | "                                                             |
| ON                                                      | "                                                             |
| OFF                                                     | "                                                             |
| AUTOCAL                                                 | "                                                             |
| HOLD                                                    | See the key descriptions in Section 3.                        |
| AUTO                                                    | "                                                             |
| DSBL                                                    | "                                                             |
| SUMENA                                                  | "                                                             |
| CHAN                                                    | "                                                             |
| MULTI                                                   | "                                                             |
| PK HLD                                                  | "                                                             |
| PK OFF                                                  | "                                                             |
| <p>(ON and OFF represent the calibrator ON/OFF key)</p> |                                                               |
| <b>NON-KEY COMMANDS</b>                                 | <b>CORRESPONDS TO</b>                                         |
| DSTEST                                                  | TEST 2 (See TEST key)                                         |
| ACCAL                                                   | SPECIAL 5 (See SPECIAL key)                                   |
| RECLIM                                                  | SPECIAL 2, 5 (See SPECIAL key)                                |
| RECOFF                                                  | SPECIAL 2, 3 (See SPECIAL key)                                |
| RECRAW                                                  | SPECIAL 2, 6 (See SPECIAL key)                                |
| RECZERO                                                 | SPECIAL 2, 4 (See SPECIAL key)                                |
| RECMEAS                                                 | SPECIAL 2, 7 (See SPECIAL key)                                |
| FREERUN                                                 | SPECIAL 1, 0 (See SPECIAL key)                                |
| FILTERED                                                | SPECIAL 1, 1 (See SPECIAL key)                                |
| SETTLED                                                 | SPECIAL 1, 2 (See SPECIAL key)                                |
| TRFILTER                                                | SPECIAL 1, 3 (See SPECIAL key)                                |
| TRSETTLE                                                | SPECIAL 1, 4 (See SPECIAL key)                                |
| BATTEST                                                 | TEST 7 (See TEST key)                                         |
| GRAPHON                                                 | SPECIAL 7 (See SPECIAL key)                                   |
| GRAPHOFF                                                | SPECIAL 7 (See SPECIAL key)                                   |
| KEYTEST                                                 | TEST 1 (See TEST key)                                         |
| MEMTEST                                                 | TEST 3 (See TEST key)                                         |
| RAWCHAN                                                 | SPECIAL 8 (See SPECIAL key)                                   |
| TRIGGER (or TR)                                         | SPECIAL 9 (See SPECIAL key)                                   |
| DSON                                                    | No correspondence; turns display on; See "Bus Only Commands"  |
| DSOFF                                                   | No correspondence; turns display off; See "Bus Only Commands" |
| L SUMON                                                 | SPECIAL 11 (See SPECIAL key)                                  |
| L SUMOFF                                                | SPECIAL 11 (See SPECIAL key)                                  |

poll to find out what event has occurred. The events that can be selected to generate service requests are: instrument error, measurement error, measurement is ready, zeroing is completed and requesting service from the front panel. Each of these options can be individually enabled or disabled with the 4300 SRQ mask. The default setting for the mask is with all SRQ's disabled. They can only be enabled by setting the appropriate bits high in the SRQ mask over the bus with

the SRQMASK command. The bit map for enabling SRQ's is shown in Table 3-12. See paragraph 3-142, SRQMASK.

5. Serial Poll. The Serial Poll (SP) command on the bus allows the controller to check the SRQ status byte of each instrument and determine which instrument is requesting service. The byte returned by the 4300 is made up of multiple bits representing different status and error conditions. These conditions are individually maskable, as shown in Table 3-12.

6. **Parallel Poll.** The Parallel Poll (PP) command is not supported.

**3-112. NUMBER FORMATTING.** Number formatting is shown for each of the commands in the sections that follow, but general rules are shown below:

1. Fixed or floating point formats are accepted.
2. An optional + or - may precede the mantissa and/or the exponent.
3. An optional decimal point may appear at any position within the mantissa. A decimal point in the exponent is ignored.
4. The optional "E" for exponent may be upper or lower case.
5. The following are examples of valid numeric strings:

```
-5
2.210
3e-6
3.579545E+06
-7e5
1.000e-5.
```

**3-113. MESSAGE FORMAT.** GPIB message string formatting is as follows:

1. The programming sequence is in natural order, that is, a function mnemonic is sent first followed by the argument value (parameter), if appropriate.
2. The data strings sent to the instrument are case sensitive. This means lower case and upper case are not the same.
3. Spurious numbers occurring in the Listen string are ignored.
4. All Block modes have their data arrays or ASCII strings enclosed by square brackets [ ] for error checking. Some block commands require numeric data outside of the block. This number must precede the first bracket ( [ ).
5. Multiple Listen commands may be sent in one message. Each command must be separated from the others by a delimiter character. Valid delimiters are ";", " ", " " or any other nonnumeric character between ASCII 32 (space) and ASCII 59 (semicolon). Delimiters must also be used between numeric entries, but are not necessary to separate commands from their parameter values.

The following are examples of valid 4300 message strings:

```
"SETCH1 FILT1200 SETREF -3.75 SETCH2 FILT200 DBR
MULTI"
"MULTI,LOLIM -4.5E1,HILIM 1.5E1,ZERO"
"FREQIN 2 [0.0 0.0 1.0 -0.04 1.5 -0.12]"
```

**3-114. LISTEN PARAMETER COMMANDS.** Listen Parameter Commands are listed in Table 3-7 and are commands received by the instrument that expect one numerical value to follow, for setting a particular operating

condition. Except as noted in the table, these commands correspond to specific front panel commands. "Key" commands correspond to single keystrokes; "non-key" commands are sub-modes or menu types of data entry.

**3-115.** The numeric value (parameter) can be sent in the next listen string if the listen parameter command was the last value of the previous string. If for any reason a command is sent without a parameter following it, the ESCAPE command can be used to clear the active command, or a new command can be used. The parameter number listed in the table is the number returned when the Talk Parameter mode is exercised (Talk Mode 6).

**3-116. LISTEN ACTION COMMANDS.** Listen Action Commands are listed in Table 3-8 and initiate an action without any parameters being sent. As in the Listen Parameter Commands, the "key" and "non-key" commands correspond to single keystrokes or menu types of data entry, as listed in the table.

**3-117. LISTEN ARRAY COMMANDS.** Listen Array Commands transfer arrays of data (more than one parameter) to the instrument, such as sensor data or DC calibration data, as listed in Table 3-9. The data in the arrays is enclosed within square brackets "[ ]" for error checking and must be separated by valid delimiters. The actual amount of data depends on the specific command being used. Listen Array Commands are only operable over the bus and have no corresponding front panel keys.

**TABLE 3-9. LISTEN ARRAY COMMANDS**

| COMMAND | REFER TO            |
|---------|---------------------|
| CHANSUM | "                   |
| DATAIN  | "                   |
| DCIN    | "Bus Only Commands" |
| FREQIN  | "                   |
| LEARN   | "                   |
| MESSAGE | "                   |

**3-118. TALK ARRAY COMMANDS.** Talk Array Commands are listed in Table 3-10 and build a talk string in the talk buffer for transmission. Not for general purpose measurement (use the talk modes for that), they are used for transmitting arrays of data (more than one parameter) such as sensor data and DC calibration data. The buffer contents are transmitted at the time of the next instrument talk request. These commands automatically change the Talk mode to Mode 7 or 8, depending on the data type, then reset the 4300 to talk mode 0. This is the only time that the instrument uses the talk buffer or Talk String modes (Talk Modes 7 and 8). The Talk Array commands are operable only over the bus.

**TABLE 3-10. TALK ARRAY COMMANDS**

| COMMAND | REFER TO            |
|---------|---------------------|
| DATAOUT | "                   |
| DCOUT   | "                   |
| FREQOUT | "Bus Only Commands" |
| TEACH   | "                   |

**3-119. TALK MODES.** When the 4300 is requested to talk, it will respond according to how it has been set up. The setup is either through Talk Array commands or Talk modes. The Talk modes are associated with making measurements; the Talk Array commands are associated with downloading calibration data and instrument states. The Talk modes are described below.

The 4300 supports nine talk modes of operation, as listed in Table 3-11. Once the Talk mode is set, the controller need only tell the 4300 to talk and it will respond according to the Talk mode.

Modes 0 through 6 are directly settable by the use of the TALK MODE (or TM) command. For these modes, the instrument will remain in the selected mode until the Talk mode is changed or until a Talk Array command is received. Talk modes 7 and 8 are temporary Talk modes that are automatically enabled in response to a Talk Array command (these modes can not be set by the controller directly). These temporary Talk modes are disabled (talk mode returned to zero) when the Talk Array operation is complete.

The current Talk mode is saved in nonvolatile memory and will remain in that mode when the power of the instrument is cycled on and off. The default condition for Talk mode is zero (set with the RECALL 0 operation or an instrument initialization from the rear panel Bit switch). The Talk modes are described in sections following the table.

**TABLE 3-11. TALKMODES**

| TALKMODE | DESCRIPTION                     |
|----------|---------------------------------|
| 0        | Talk Measurement Floating Point |
| 1        | Talk Measurement with Units     |
| 2        | Talk Error                      |
| 3        | Talk Error with Messages        |
| 4        | Talk Channel Status             |
| 5        | Talk Instrument Status          |
| 6        | Talk Parameter                  |
| 7        | Talk Array                      |
| 8        | Talk String                     |

**3-120. TALKMODE 0 (Talk Measurement Floating Point):**

**1. Single Channel and Summation Mode Format:**  
#1, #2

where:

#1 is the error flag (1 = error, data invalid);

#2 is the measurement in floating point notation, in the units selected (dBm, dBr, or milliwatts). In Watts mode the units are fixed in mW.

Examples:

0,0.00E00      No error, power is 0.00 dBm.  
1,-75.00E00    Under range error at -75 dBm.  
0,98.9E00      No error, power is 98. milliwatts.  
1,50.85E00     High Limit exceeded at 50.85 dBr.

**2. Multichannel Mode Format:** EF, #1, #2, #3, #4, #5, #6,  
where:

EF is the error flag, (1 = data invalid);

#1 through #6 are the measurements in floating point notation, in the units selected (dBm, dBr or milliwatts). In Watts mode the units are fixed in mW.

Note that in Multichannel mode, measurements will be reported only for installed channels. If the Model 4300 has four channels installed, the Talk message will contain five values - the error flag plus four measurements. No error or value will be generated for the channels that are not present.

Example:

0,0.00E00,1.00E06,-20.00E00,-75.00E00 — All readings are correct. Channel 2 has the units set to watts and channels 1,3,4 are set to dBm. Only 4 channels are installed in the unit, so only 4 numbers are returned.

**3-121. TALKMODE 1 (Talk Measurement with Units).**

**1. Single Channel and Summation Mode Format:**

EF, #1

where:

EF is the error flag (1 = error);

#1 is the measurement. The format is fixed point followed immediately by a three character string that indicates the units of the measurement. The possible units are "dBm", "dBr", "dB", "nW", "uW", "mW", "W", "% and ". The "%" and "dB" are for when the instrument is in the summation mode. The " " indicates the value is raw data (See SPECIAL function 8).

If need be, the string can be parsed externally into a number and three character message.

Examples:

0,0.00dBm      No error at 0.00 dBm.  
1,-75.00dBm    Under range error at -75.00 dBm.  
0,98.9uW       No error at 98.9 microwatts.  
1,50.85dBr     High Limit exceeded at 50.85 dBr.

2. **Multichannel Mode Format:** EF,#1,#2,#3 #4,#5,#6  
where:

EF is the error flag (1 = error);  
#1 through #6 are the measurements. The format is fixed point followed immediately by a three character string that indicates the units of the measurement. The possible units are "dBm", "dBr", "dB", "nW", "uW", "mW", "W", "%", and ". The "%" and "dB" are for when the instrument is in the summation mode. The "." indicates the value is raw data (refer to SPECIAL function 8). Only installed channels return measurements.

If need be, the string can be parsed externally into a number and a three character message.

Example:

0,0.00dBm, 1.00mW, -20.00dBm, -75.00dBm — All readings are correct. Channel 2 has the units set to watts and channels 1,3,4 are set to dBm.

### 3-122. TALKMODE 2 (Talk Error).

1. **Format:** #1,#2,#3

where:

#1 is the instrument error number, from 0 to 70. A "0" indicates no error. Refer to Table 3-13 for the error messages.

#2 is the measurement error, from 0 to 70. A "0" indicates no error. Refer to Table 3-13 for the error messages.

#3 is the channel(s) reporting errors, from 1 to 7 sequential digits. Each digit represents a channel (1-6), and a 0 represents the control board or mainframe. A channel will report an error if any error has occurred since the error condition was last cleared. Errors are cleared by the execution of a Talk Error operation or an ESCAPE command.

The execution of this Talk mode automatically clears the instrument error after it is reported. If more than one error occurs, the instrument will indicate the first one that occurred.

Examples:

|             |                                                                                 |
|-------------|---------------------------------------------------------------------------------|
| 0,0,0       | No error is reported.                                                           |
| 0,3,2       | Channel 2 is underrange.                                                        |
| 0,14,123456 | No channels are installed in the instrument for Multichannel mode measurements. |
| 24,0,0      | Frequency entry is out of range for sensor data table.                          |
| 1,0,0       | Number entry is out of range for selected function.                             |
| 1,3,2       | Number entry is out of range and channel 2 is underrange.                       |

### 3-123. TALKMODE 3 (Talk Error with Message).

1. **Format:** #1,#2,#3,"MSG"

where:

#1 is the instrument error number, from 0 to 70. A "0" indicates no error. Refer to Table 3-13 for the error messages.

#2 is the measurement error, from 0 to 70. A "0" indicates no error. Refer to Table 3-13 for the error messages.

#3 is the channel(s) reporting errors, from 1 to 7 sequential digits. Each digit represents a channel (1-6), and a 0 represents the control board or mainframe. A channel will report an error if any error has occurred since the error condition was last cleared. Errors are cleared by the execution of a Talk Error operation or an ESCAPE command.

"MSG" is the message portion, consisting of 15 characters. This message is exactly the same as the error message that appears in the upper right hand corner of the front panel display in local operation. If an instrument error and a measurement error are both reported the message will describe the instrument error because it is considered potentially more important.

The execution of this Talk mode automatically clears the instrument error after it is reported. If more than one error occurs, the instrument will indicate the first one that occurred.

Examples:

|                        |                                                                                                       |
|------------------------|-------------------------------------------------------------------------------------------------------|
| 0,0,0,                 | No error is active.                                                                                   |
| 0,3,2 Err Under RANGE  | Channel 2 is underrange.                                                                              |
| 0,14,123456,           | No channel as are installed in the instrument for multichannel mode.                                  |
| No channel Card        | Frequency entry is out of range for sensor table. Number entry is out of range for selected function. |
| 24,0,0,Out of Freq Rng | Number entry is out of range and channel 2 is underrange.                                             |
| 1,0,0Err Range of #    |                                                                                                       |

### 3-124. TALKMODE 4 (Talk Channel Status).

1. **Format:** #1,#2,#3,#4,#5,#6,#7

where:

#1 is the selected channel to which the following data pertains to.

#2 is the channel status or type, according to the table below:

Section 3  
Operation

- 13 The Channel has a battery error.
- 14 The Channel card is reporting an error.
- 15 The Channel has a memory error.
- 16 The Channel slot is filled with a special trigger option.

#3 is the measurement units that the channel is set to, according to the following table:

- 0 Power in Watts, mW,  $\mu$ W, or nW.
- 1 Power in dBm.
- 2 Power in dBr.
- 10 Reading is the raw value.

#4 indicates the Trigger mode of operation.

- 0 Free Run.
- 1 Free Run Filtered.
- 2 Free Run Settled.
- 3 Trigger Filtered.
- 4 Trigger Settled.

#5 indicates if the channel has the duty cycle enabled (1 = enabled).

#6 indicates if the channel is currently performing a zero operation, according to the following table:

- 0 Channel not zeroing.
- 1 Channel is decaying.
- 2 Channel is checking if zero can be done.
- 3 Channel is settling.
- 4 Channel is performing zeroing operation.

#7 indicates the software revision number of the channel EEPROM.

**NOTE**

The mode of operation of the instrument (Single Channel, Multichannel or summation channel) does not affect the operation of this Talk mode.

Examples:

1,1,1,0,0,0,1.00 — Channel 1 is a universal card with its units in dBm, in free run mode with no duty cycle correction applied. The channel is not presently being zeroed. The software level of the channel card is 1.00.

6,1,2,2,1,3,1.00 — Channel 6 is a universal card with its units in dBr, in free run settled mode with a duty correction applied. The channel is presently being zeroed. The software level of the channel card is 1.00.

**3-125. TALKMODE 5 (Talk Instrument Status).**

1. **Format:** #1,#2,#3,#4  
where:

#1 is the current operation mode, according to the table below:

- 0 Single Channel mode.
- 1 Multichannel mode.
- 2 Summation mode.

#2 is the calibrator activity indicator (30 MHz programmable calibrator only; 1 = output is enabled and 0 = output disabled).

#3 is the control board software version.

#4 is the programmable calibrator calibration date. If not installed, a 0/00 is returned.

Examples:

0,0,1.00,0/0 — The instrument is in single channel mode with the programmable calibrator turned off. The software version is 1.00 and the programmable calibrator is not installed in the instrument.

2,1,1.00,1/87 — The instrument is in the Summation mode with the calibrator output on. The software version is 1.00 and it was last calibrated in January 1987.

**3-126. TALKMODE 6 (Talk Parameter).**

1. **Format:** #1,#2  
where:

#1 is the active parameter number (0 = no parameter selected).

#2 is the active parameter value, for example "frequency". The units are defaulted.

2. This command returns two numbers which describe the current "opened" (or selected) parameter in the instrument and its value. For example, the frequency that a channel is set to can be read over the bus. To read a parameter, it must be "opened" first as described below. A parameter in the 4300 is defined to be a front panel or bus command that allows or requires a numerical value to be entered into it. The parameters are listed in Table 3-2., and the parameter numbers are listed in Table 3-7.

3. The data sent over the bus is the same as the data displayed in the entry field in the upper right corner of the display whenever a parameter is selected. This information is generally retrieved from the instrument in the single channel mode, because the parameters are generally different for each channel. In Multichannel and Summation modes, if the parameters are different, (for example if the channels have different digital filter lengths), no parameter will be returned on the bus. The Talk Parameter command will act

as if no parameter was open. Incidentally, if in Local mode, the display would be blank in this case.

4. To use this Talk mode, the instrument is first placed in Talk Mode 6, then a parameter is opened (made active) by pressing the appropriate key or by sending the bus command. No numeric value should follow and the Escape command should not be used. Then, while the parameter is active, a Talk command is issued to the instrument, and the data for that parameter will be sent out on the bus. To deactivate a parameter, simply enter a number, send another command, or issue the Escape command.

Examples:

0,0 — No parameter is active and the second value should be ignored.

2,-10,00 — The set dB reference (parameter number 2) is currently set to -10.00 dBm.

5,1 — Sensor 1 is assigned to the current channel.

3,1.23 — The frequency is set to 1.23 GHz.

### 3-127. TALKMODE 7 (Talk Array).

1. **Format:** Each of the different Talk Array commands has a different format; refer to the applicable paragraph, Bus Only Commands.

2. Not directly settable by the controller, this Talk mode builds a data string in the talk buffer for a one time transmission. It is used to send an array of numerical data or a string of character data in the "teach" modes (downloading sensor and/or calibration data). This mode is set internally automatically by the execution of one of the Talk array commands. Once executed, this mode is automatically cleared to talk mode 0 as the default condition.

### 3-128. TALKMODE 8 (Talk String).

1. **Format:** Each of the different Talk String commands has a different format; refer to the applicable paragraph, Bus Only Commands.

2. Not directly settable by the controller, this command is set automatically by use of the Teach command. This command is a special case to allow the transmission of data that is longer than one buffer. This command is only used by the Teach command. This mode is always cleared to Talk mode 0 when the teach operation is completed.

### 3-129. IEEE-488 BUS ONLY COMMANDS.

This section covers commands that are available only under remote operation on the bus.

**3-130. TALKMODE.** The Talk mode command is used to change a selected Talk mode. The range of data for this command is from 0 to 6. Talk mode 7 and 8 can only be set indirectly by the execution of a Talk Array command. This command can be abbreviated as TM for simplicity. This command is classified as a Listen Parameter command.

Example:

TALKMODE 0 — Set talk mode 0 (Talk Measure).

TM 3 — Set talk mode 3 (Talk Error with Message).

**3-131. DATAIN.** Used in conjunction with the DATAOUT command, this command is used to send a portion of the sensor calibration data to the 4300, in the form of an array of numeric data. In this way, sensor data can be transferred from one instrument to another, or stored on a disk.

This command is used in the single channel mode. Sensor data is loaded for sensors 1-20, based upon what sensor is assigned to the selected channel. For example, if sensor 16 is assigned to channel 2, and channel 2 is currently selected, then the data that is entered will automatically be placed in the data bank for sensor 16. Temporary sensor to channel assignments may be made over the bus to enter data for currently unused sensors.

1. The data is the 14-point linearity data (AC reference frequency linearity data) for a selected sensor and is placed in the sensor data bank (independent of channels). This command corresponds to a subsection of the Sensor Data Entry command which is available from the keyboard. This command complements the DATAOUT command over the bus; the DATAOUT command would normally be the source of the data string for this command. This command is classified as a Listen Array Command.

2. In addition to the 14-point data, each sensor has high frequency calibration data, which is loaded with the FREQIN command.

3. **Format:** DATAIN [sensor type, sensor serial number, U0, U1, U2, U3, U4, U5, U6, D0, D1, D2, D3, D4, D5, D6].  
where:

sensor type is a number in the form 51XXX. Sensors types must be resident in the instrument firmware. To access the resident types, scroll through the sensor type menu within the SENSOR DATA ENTRY key from the front panel.

sensor serial number is from 1 to 999999.

U0 through U6 are the Upscale gain factors (1000 to 10000, nominally 5000).

D0 through D6 are the downscale factors (-200 to +200).

4. Each numeric value must be separated by a valid delimiter. The square brackets need to have at least one space on each side of them for correct operation, except the trailing one if it is the last character to be sent.

Example:

DATAIN [ 51013, 12345, 5012, 5003, 5032, 5013, 4995, 5005, 4891, -20, -21,2,-3,-14,15,6 ]

**3-132. DATAOUT.** Used in conjunction with the DATAIN command, this command is used to send sensor calibration data out to the controller. See the DATAIN command for descriptions of the general use of these commands. Sensor data also consists of high frequency calibration data, which is handled with the FREQOUT command.

1. When executed, this command instructs the instrument to build an array of numeric data in the talk buffer for transmission at the next talk request. The array consist of numeric data representing the 14 point linearity data (AC calibration data) for a selected sensor. This command corresponds to a subsection of the Sensor Entry command which is available from the keyboard. This command complements the DATAIN command would normally be the destination of the data string of this command. The DATAOUT command is classified as a Talk Array Command.

2. The Talk mode is temporarily set to 7 (talk array) when this command is executed. After this talk command has been executed, the Talk mode is reset to 0 (talk measure). An Escape command will also reset the Talk mode.

**3. Format:**

(To the instrument in a listen string): DATAOUT.  
(From the instrument in the next talk string): [sensor type, sensor serial number, U0, U1, U2, U3, U4, U5, U6, D0, D1, D2, D3, D4, D5, D6 ]

See the DATAIN command for the format descriptions.

4. Each numeric value must be separated by a valid delimiter. The square brackets need to have at least one space on each side of them for correct operation, except the trailing bracket if it is the last character to be sent.

Example:

To the instrument in a listen string: DATAOUT.

From the instrument in the next talk string: [ 51013, 12345, 5023, 5001, 5012, 5010, 4997, 5005, 5003, 10, 13, -2, -23, 14, -15.6 ]

**3-133. FREQIN.** Used in conjunction with the FREQOUT command. This command is used to send sensor high frequency calibration data to the 4300 for a selected sensor in the form of an array. In this way, sensor data can be transferred from one instrument to another, or stored on a disk. In addition to the high frequency calibration data, there is the 14-point calibration data, which is loaded with the DATAIN command.

1. The data is for the selected sensor, and is placed in the sensor data bank independent of channel assignment. This command corresponds to a subfunction of the Sensor Data Entry procedure available from the keyboard. This command complements the FREQOUT command over the bus; the FREQOUT command could be used as the source of the data string for this command. This command is classified as a

Listen Array command. The data is loaded in blocks of 15 points.

**2. Format:**

FREQIN n [ F1,DBCf1,F2,dBCf2....F15,DBCf15 ]

where:

n is the pointer, see text below, from 1 to 80;

F1 is the first frequency of this group, from 0.00 to 110 GHz in .01 GHz increments;

DBCf1 is the first dB Cal Factor for this group, from -3.00 to 3.00 dB in .01 dB increments;

3. Each numeric value must be separated by a valid delimiter. The square brackets need to have at least one space on each side of them for correct operation, except the trailing bracket if it is the last character to be sent.

4. The total number of frequency points is limited to 80 for sensors 1 through 6, and 35 for sensors 7 through 20. The pointer indicates the starting location for the frequency/dB Cal factor pairs. The pointer must not exceed 65 if the group contains 15 points, for a total of 80 points. Likewise, the pointer must not exceed 20 for sensors 7 through 20, if the frequency group has 15 points.

5. Frequency Cal points must be in numerical order of frequency. Generally, the first point is at 0 GHz or .01 GHz, with a Cal Factor of 0, so that in the operating mode, frequencies down to .01 GHz can be entered.

**Examples:**

FREQIN 1 [ 0.00,0.00, 1.00, -0.05, 2.00, -0.07, 3.00, -0.10,4.00,-0.06,5.00,-0.05,6.00,0.00,7.00,0.13,8.00, 0.42,9.00,0.34,10.00,0.00,11.00,0.15,12.00,0.32,13.00, 0.25,14.00,0.43 ]

FREQIN 16 [16.00,0.00,17.00,-0.50,18.00,-0.12, 19.00,-0.10,20.00,0.06,20.05,0.05,20.10,0.04,20.15, 0.03,20.20,0.04,21.00,0.04,25.00,0.05 ]

**3-134. FREQOUT.** Used in conjunction with the FREQIN command, this command is used to send sensor high frequency calibration data out to the controller. See the FREQIN command for descriptions of the general use of these commands. Data points are loaded in blocks of 15.

1. When executed, this command instructs the instrument to build an array of numeric data in the talk buffer for transmission by the next talk request. The array consists of numeric data representing the dB cal factor information for a selected sensor. This command is a subfunction of the Sensor Entry procedure which is available from the keyboard. The FREQOUT command is classified as a Talk Array command.

2. The Talk mode is temporarily set to 7 (talk array) when this command is executed. After the talk command has been executed, the Talk mode is reset to 0 (talk measure). An Escape command will also reset the Talk mode.



3. **Format:** To the instrument in a listen string:  
FREQOUT n

From the instrument in the next talk string: [ F1, DBCF1,  
F2, dBCF2, ..., F15, dBCF15 ]

where:

n is the pointer, see text, from 1 to 80;

F1 is the first frequency of this group, from 0.00 to 110  
GHz in .01 GHz increments;

DBCF1 is the first dB Cal Factor for this group from -3.00  
to 3.00 dB in .01 dB increments; etc.

4. Each numeric value must be separated by a valid  
delimiter. The square brackets need to have a least one space  
on each side of them for correct operation, except the trailing  
bracket if it is the last character to be sent.

5. Refer to the FREQIN command for limitations on the  
pointer and starting frequencies, and for general use of this  
command.

Example:

Command sent to the instrument: FREQOUT 1

The numeric array built into the talk buffer: [ 0.00,  
0.00,1.00,-0.05,2.00,-0.07,3.00,-0.10,4.00,-0.06,5.00,  
-0.05,6.00,0.00,7.00,0.13,8.0,0.42,9.00,0.34,10.00,  
.00,11.00,0.15,12.00,0.32,13.00,0.25,14.00,0.43 ]

**3-135. DCIN.** Used in conjunction with the DCOUT  
command, this command is used to send DC calibration data  
to the instrument for a selected input channel, in the form of  
an array. In this way, calibration can be done in an automatic  
test station. Also, calibration data can be retrieved from a  
calibrated unit and stored on a disk.

1. The data consists of a gain constant for each range, and  
an ADZERO term, which is a downscale adjustment. It is  
stored on each channel board in nonvolatile RAM.

2. This command corresponds to the SPECIAL 3 command  
which is available from the keyboard. This command  
complements the DCOUT command, and is classified as a  
Listen Array Command.

3. **Format:** DCIN [ G0,G1,G2,G3,G4,G5,G6,AD-  
ZERO ]

where:

G0 through G6 are the gain constants for ranges 0 through  
6, ranging from 4000 to 7500 (nominally 5000);

ADZERO is the downscale adjustment, ranging from -15  
to 15, nominally 0.

4. Each numeric value must be separated by a valid  
delimiter. The square brackets need to have at least one space  
on each side of them for correct operation, except the trailing  
bracket if it is the last character to be sent.

Example:

DCIN [ 5000,5001,5002,5003,5004,5005,5006,-1 ]

**3-136. DCOUT.** Used in conjunction with the DCIN  
command, this command is used to transfer DC calibration  
data to a controller for later reentry into the instrument.

1. When executed, this command instructs the instrument  
to build an array of numeric data in the talk buffer for

transmission by the next talk request. The array consists of  
a gain constant for each range, and an ADZERO term which  
is a downscale adjustment. It is stored on each channel  
board in nonvolatile RAM.

2. This command corresponds to the Special 3 function  
available from the keyboard. The DCOUT command is  
classified as a Talk Array Command.

3. The Talk mode is temporarily set to 7 (Talk array)  
when this command is executed. After the talk command  
has been executed, the Talk mode is reset to 0 (talk measure).  
An Escape command will also reset the Talk mode.

4. **Format:** To the instrument as a listen string:  
DCOUT

From the instrument in the next talk string: [ G0,G1  
G2,G3,G4,G5,G6,ADZERO ]

where:

G0 through G6 are the gain constants for ranges 0 through  
6, ranging from 4000 to 7500 (nominally 5000, except range  
6 which is 6635);

ADZERO is the downscale adjustment, ranging from -15  
to 15, nominally 0.

5. Each numeric value must be separated by a valid  
delimiter. The square brackets need to have a least one  
space on each side of them for correct operation, except the  
trailing bracket, if it is the last character to be sent.

Example:

To the instrument in a listen string: DCOUT

From the instrument in the next talk string:  
[ 5000,4889,5002,5029,5034,4990,6645,-1 ]

**3-137. DSOFF.** This command is classified as a Listen  
Action

Command. Its functions are 1) to blank the front panel  
display, for secure ATE applications, 2) to allow user  
messages to be displayed on the front panel, and 3) to speed  
up operation by reducing the number of tasks that must be  
performed by the 4300. When the display is turned off, the  
display hardware is still functional but it is not updated for  
certain types of information. The data that is still displayed  
are any messages sent to the display by the MESSAGE  
command and also instrument status (displayed in the lower  
right of the display). The instrument status includes the  
IEEE-488 bus status (M for MATE, REM for REMOTE,  
TLK or LSN for TALK or LISTEN and SRQ for Service  
Request Activity), keyboard shift indicator and  
programmable calibrator output indicator.

**3-138. DSON.** This command enables the front panel  
display, complementing the DSOFF command. This  
command is classified as a Listen Action Command.

**3-139. TEACH.** In response to this command, the 4300  
will send three strings of data that represent a selected  
instrument setup states. An instrument state contains all  
operating and channel parameters; see the description of  
the RECALL key for what information is included.

Section 3  
Operation

1. Each of the three strings are transmitted as separate talk strings and may be up to 256 characters long. This command is the complement to the LEARN command and is classified as a Talk Array command. Refer to the LEARN command.

2. **Format:** To the instrument: TEACH n  
From the instrument: (data string)

where:

n is the register from 0 to 9 from which the setup is taken. Register 0 is the one that the instrument operates from (loading a setup from register 0 will output the current operating state).

3. This command automatically sets the Talk mode to level 8 which is Talk String. This command will transmit three buffers of data and then automatically set the Talk mode to 0. If an ESCAPE command is sent while the data strings are being sent, the Talk mode is set to 0 and the TEACH command sequence is aborted.

4. The teach string is of arbitrary sequence and can only be generated from a 4300, and downloaded to a 4300 with the identical software revision.

**3-140. LEARN.** In response to this command, the 4300 will expect three strings of data that represent one of the instrument setup states, to be stored in one of ten registers. Each of these strings are received as a separate listen string and may be up to 256 characters long. This command is the complement to the TEACH command and is classified as a Listen Array command. Refer to the Teach command for general information.

1. **Format:** LEARN n (data array)

where:

n is the register from 0 to 9 to store the setup in. Register 0 is the one that the instrument operates from (loading a setup into register 0 will cause the instrument to work with that setup immediately).

(data array) is a 4300 generated string of arbitrary format.

2. The learn string is of arbitrary sequence and can only be generated from a 4300 with an identical software revision.

3. Caution must be exercised when using this command because any error in this string could corrupt calibration data for the sensors and possibly the channel cards.

**3-141. MESSAGE.** This command is used to display messages on the front panel display of the instrument. It expects a pointer value followed by an ASCII string. The pointer indicates the location on the display to start displaying the message. This command is only operable when the DSOFF bus command has already been executed. To clear a previous message, a DSOFF command may be sent at any time. This command is classified as a Listen Array Command.

1. **Format:** MESSAGE n [ displayed message ]  
where:

n is the pointer which marks the beginning location of the message, from 0 to 43. See text.  
displayed message is an ASCII string, up to 64 characters.

2. The message field of the display starts with the left most character on the top line and includes all 40 characters on the top line, continuing with the second line. No embedded line feed or carriage return should be sent within the message.

3. The display will display 256 character types (all of the standard ASCII characters plus special ones that are in place of the control codes and upper 128 characters).

Examples:

MESSAGE 1 [ Boonton Test Program 1 ];

MESSAGE 40 [ Test n Progress ];

DSOFF MESSAGE 10 [ This is Powermeter Number Three ].

**3-142. SRQMASK.** This command is used to set the SRQ mask which selectively enables 4300 generated GPIB service requests. This command is classified as a Listen Parameter command.

1. The range of numeric entry is from 0 to 255. The SRQ mask is logically ANDed with the SRQ sources to determine if an SRQ should be generated. For more information on SRQ and the related serial poll, refer to Paragraph 3-111.

2. The SRQ bit map is shown in Table 3-12.

**TABLE 3-12. SRQ MASK**

| Bit | Description                                                                                                   |
|-----|---------------------------------------------------------------------------------------------------------------|
| 0   | Bit set indicates that an instrument error has occurred.                                                      |
| 1   | Bit set indicates that a measurement error has occurred.                                                      |
| 2   | Bit set indicates that a measurement is ready.                                                                |
| 3   | Bit set indicates that a zeroing command is complete.                                                         |
| 4   | Not used: should be reset.                                                                                    |
| 5   | Bit set indicates that front panel button is pressed.                                                         |
| 6   | Bit set indicates that an SRQ is active. (This is a summary bit used in serial poll; it is not a masked bit.) |
| 7   | Not used: should be reset.                                                                                    |

Examples:

SRQMASK 0 — Disable all service request.

SRQMASK3 — Enable SRQ only on instrument and measurement errors.

SRQMASK 8 — Enable service request only when a zeroing operation is completed.

**3-143. CHANSUM.** This command is similar to the keyboard command CHAN Σ, however, the format and type of data sent over the bus needs additional specification. Refer to the CHAN Σ key. This command is classified as a Listen Array Command.

1. **Format:** CHANSUM [ n+m+p-q ] (typical)

where:

n, m, p, and q are channel numbers (1-6).

2. The equation can consist of up to six channel numbers, separated only by + or - signs. Extra characters of any kind including spaces are not allowed within the equation but extra spaces or delimiters are allowed between the equation and the square brackets. The + and - signs are used without concern for the present operating units of the instrument (dBm or Watts). If the instrument is in dBm mode, the equation represents a summation of dB, and the result is in dB. If the instrument is operating in the watts mode, the + and - signs will be interpreted as multiply and divide signs, indicating a power ratio (result in percent).

Examples:

CHANSUM [ 1-2 ]

CHANSUM [ 1+3-2+4-5+6 ]

CHANSUM [ 3+6-4 ]

### 3-144. GPIB PROGRAMMING EXAMPLES.

1. The following programming examples demonstrate the bus operation of the 4300. The examples are shown in a general format of BASIC and are not an example of any specific implementation of the language syntax. The examples also assume that the 4300 is the only instrument connected and that all commands default to the GPIB address of the 4300.

2. In the examples, "INPUT" refers to the case where the instrument is the talker; "OUTPUT" indicates that the controller is the talker. The vertical slash (/) is used to mark comments.

**EXAMPLE 1:** Take a reading on channel 1 after zeroing the channel with the following setup:

Filter set to 1 second.

Frequency set to 5 GHz.

Reading in dBm.

**Program:**

VARIABLE T#1,T#2, T#3,T#4,T#5,T#6

```

OUTPUT "RECALL 0" | Clear all previous setups.
OUTPUT "FILTER 1000" | Set the filter to 1000ms.
OUTPUT "FREQ 5" | Set the frequency to 5 GHz.
OUTPUT "ZERO" | Start the zeroing of the channel.
OUTPUT "TALKMODE 4" | Set talk mode to channel status.
BEGIN
  WAIT 0.01 | Short delay.
  INPUT T#1,T#2,T#3,T#4,T#5,T#6
  | The 7th value can be ignored.
  UNTIL T#6 = 0 | Loop until zeroing done.
OUTPUT "TALKMODE 0" | Set talk mode to measure.
INPUT T#1 | T#1 contains the power in dBm.
PRINT T#1 | Print the power reading.

```

### EXAMPLE 2: Triggered Summation Measurement.

**Objective:** Measure the power difference repetitively between channels 3 and 4, using channel 4 as the reference point. The measurement must be synchronized by a trigger command and only a settled reading is to be returned. Compensation must be included for a 10 dBm attenuator in line with the sensor on channel 4.

**Program:**

VARIABLE: T#1

```

OUTPUT "CHANSUM 4-3" | Enter summation equation.
OUTPUT "SETCH 4" | Select channel four.
OUTPUT "SETREF -10" | Enable dBm to compensate for
| in line attenuator.
OUTPUT "SUMENA" | Enable the summation mode.
OUTPUT "TRSETTLE" | Set all channels to trigger settled
| readings.
OUTPUT "TRIGGER" | When ready to take read
| Trigger all channels in
| summation mode.
INPUT T#1 | The power difference returned
| When ready to take read
OUTPUT "TRIGGER" | Trigger all channels in
| summation mode.
INPUT T#1 | The power difference returned.

```

### EXAMPLE 3: Change the sensor assignment and execute an autocalibration.

**Objective:** Assign the sensor entered into entry 7 to channel 1, and perform an automatic multi-point calibration on it.

**Program:**

```

VARIABLE T#1
OUTPUT "SETCH 1" | Select channel 1
OUTPUT "ASSIGN 7" | Assign sensor 7 to channel 1
OUTPUT "AUTOCAL" | Initiate the autocalibration routine
| which will execute the
| multi-pt calibration if the
| correct sensor is connected to
| the programmable calibrator.
| The instrument will take 2 minutes or so for this calibration
| depending on the sensor type being calibrated. Any attempt at
| bus communications will be held up until the autocal procedure is completed.
OUTPUT "TALKMODE 2" | Set talk mode to talk error
INPUT T#1 | Check if autocal was performed
IF T#1 <> 0 THEN PRINT "Calibration Error check sensor"
| If an error has occurred, then report
| the error

```

### 3-145. ERROR MESSAGES.

The error messages returned over the bus are described in Table 3-13. They are in numerical order as would be sent out over the GPIB. The first line is the message that appears on the right hand side of the display when the error occurs and would also be sent out over the GPIB in the Talk Error Message mode. The paragraphs that follow each message are an explanation and provide some hints at possible causes for the error.

**TABLE 3-13. ERROR MESSAGES**

- 1 Err Range of #**  
An error generated when the entered value is not within the accepted range of the function expecting the number.
- 2 Err # off DIGITS**  
An error generated by keyboard entry only. It indicates that too many digits or decimal places in a number have been entered.
- 3 Err Under RANGE**  
This error can occur under two different conditions: 1) In autorange when the power level is below -75 dBm, and 2) In hold range mode when the power level is below the level that can be measured on the present range.
- 4 Err Over RANGE**  
The error can occur under two different conditions: 1) In autorange when the power level is above the measurement range of the sensor, and 2) In hold range when the power level is above the level that can be measured on the present range.
- 5 Err ERROR**  
This error code is presently not used.
- 6 Unable to Zero**  
One or more channels cannot perform a zero operation because the sensor(s) have a power level applied to it. Sensors will zero at power inputs less than about a full-scale signal on range 0. Channels with no sensors connected will float to an undetermined level and usually appear to have power applied that is too high to zero.
- 7 Err ERROR**  
This error code is presently not used.
- 8 Err Sensor S/N**  
This error is generated when a sensor serial number is entered into the Sensor Data S/N function and no match is found (the serial number does not reside in the sensor data bank).
- 9 Err Zeroing Ch**  
This error is generated when a measurement is attempted on a channel while it is trying to perform a zeroing operation.
- 10 Not Supported**  
This error response indicates that an attempt is being made to use a feature or command which is not available in this version of the instrument or in the present operating mode.
- 11 Err Low Limit**  
This error indicates that the present power reading is below the low limit setup for that channel. Refer to the LO LIMIT key. A blinking down arrow also appears between the channel number and the power reading on the front panel display.
- 12 Err High Limit**  
This error indicates that the present power reading is above the high limit setup for that channel. Refer to the HI LIMIT key. A blinking up arrow also appears between the channel number and the power reading on the front panel display.
- 13 Err Measurement**  
This error message indicates an error in the measurement parameters which could cause the resulting measurement values to be unacceptable.
- 14 No Channel Card**  
This error message is generated when a channel is selected that has no card installed or the card is not functioning properly. This error is only generated in response to the SET CH (Set Channel) function.
- 15 No Calibrator**  
This error message indicates that no 30 MHz programmable calibrator is installed. The fixed 50 MHz power reference is not related to this message.
- 16 Battery Failure**  
This error is generated by the battery test which is performed at power on and upon request. When this error occurs, the channels or the control board can cause the failure. The failing subsection of the instrument can be identified by the channel error number in the talk error message and also on the front panel display on the bottom line of the error reporting field.

**TABLE 3-13. ERROR MESSAGES (Cont.)**

**17 Err Chan Card**

This error is generated by the channel module when it determines that one of its subsections is not working properly.

**18 Err Memory Test**

This error is generated by the memory test which is performed at power on and upon request. Both channel and control board memory faults can cause this error. The failing subsection can be identified by the channel error number in the talk error and also on the front panel display.

**19 Err ERROR**

This error code is presently not used.

**20 Err Raw Measure**

This error is generated when a channel is commanded, but is unable to go to the Raw Data mode due to its current operating mode. The modes that will generate this error are the Duty Cycle mode and the Summation mode.

**21 Chan Mode Only**

This error is generated when a special calibration operation is selected which can only be performed in the Single Channel mode.

**22 Err  $\Sigma$  Equation**

This error message is caused by the improper entry of the equation that is used for the Summation mode. One case when entered from the keyboard is that less than two or more than six numbers have been entered. On the bus it could be illegal syntax, an improper message format or illegal string characters.

**23 Err Cal Limit**

This error is generated when a calibrator level is entered that exceeds the calibrator limit previously stored in the instrument. Refer to the Calibrator Limit key. When this error occurs the cal level is not changed because this feature is used to protect a power sensitive device connected to the calibrator.

**24 Out of Freq Rng**

This error is generated when an operating frequency is entered that is out of range of the active sensor's previously entered frequency calibration factors. Refer to the FREQ key. For proper operation, the frequency points must be in numerical order starting with the smallest first. It is recommended that the first entry be the lowest number that might ever be used with the instrument.

**25 Err Sensor Type**

The error message only occurs as part of the sensor data entry function. This response indicates that the sensor type entered is not listed in the firmware table.

**26 Err ERROR**

This error code is presently not used.

**27 Err ERROR**

This error code is presently not used.

**28 Err Pulse Meas**

This error is reported as a measurement error in the Duty Cycle mode and indicates that a diode sensor is operating out of the square law region and that the calculated pulse power is incorrect.

**29 Err Recall Data**

The instrument setup register is corrupted or invalid.

**30 Err Bus Buffer**

This error message occurs only when the GPIB is used and the instrument listen operation receives a string greater than 512 characters which causes the internal buffer to overflow. When this occurs, all of the commands in the message are ignored. The only time that this is likely to be a problem is when sending an FNC in MATE. In this case, two consecutive FNC strings can be sent. If the error occurs after a series of short messages, then it may be that the terminator characters are not correct or the EOI is not being sent, causing the instrument to interpret multiple messages as one string.

**31 Err Bus Command**

This error is generated by the reception over the bus of a command string that is unrecognized by the instrument. To assist in bus debugging refer to the bus test feature. See the TEST key.

**32 Err Bus String**

This error indicates that the bus buffer or teach and learn block modes are not delimited properly by square brackets.

**TABLE 3-13. ERROR MESSAGES (Cont.)**

- 33 Err ERROR**  
This error code is presently not used.
- 34 Err AC CAL ###**  
This error is generated during the execution of automatic AC 14-Point Calibration for the sensors. The ### is the first level in dBm at which the instrument was unable to generate new correction factors.
- 35 Err Sensor Cal**  
This error occurs when a multipoint calibration (autocalibration) is attempted on a channel that has a waveguide sensor assigned to it.
- 36 Multi-Pt Err###**  
This error occurs in response to an autocal request. It indicates that the sensor is connected to the programmable calibrator but the power readings are not within the expected windows. A check for poor connection path or external attenuator in the signal path should be done. The ### is the power level in dBm where the first failure occurred. To verify the error, check the level indicated by the ### value by hand on the instrument. This will indicate if the calibrator has failed at that specific point.
- 37 AutoCal Error**  
Similar to Error 36, but is generated at a different point in the routine. No power level is returned. A check for proper sensor type, poor connection path or external attenuator still in the path should be done.
- 38 Err Cal Exited**  
This message is not actually an error, since it can only be generated by operator intervention. This is the response to pressing the ESC key during the autocal procedure. It is necessary to inform the operator or computer that the operation was aborted.
- 39 Err Fixed Cal**  
This error message occurs when the autocal procedure is selected but the sensor is not connected to the programmable calibrator. This could be that the calibration is not at or close to the 0 dBm or -20 dBm points which are the only fixed point cal levels supported. Other causes for error: wrong sensor type assigned, external signal path loss, or instrument malfunction.
- 40 Protected Data**  
This error occurs if sensor data, calibration data, or DC channel card calibration is being accessed while an internal or rear panel bit switch is set to protect this data. Also, the 30 MHz programmable calibrator has a jumper which protects the calibration data. Refer to the Adjustments section for information on how to unprotect the data.
- 41 Err Cal Signal**  
The measured signal in the autocalibration operation is out of range.
- 42 Err ERROR**  
This error code is presently not used.
- 43 Err ERROR**  
This error code is presently not used.
- 44 Err ERROR**  
This error code is presently not used.
- 45 Err ERROR**  
This error code is presently not used.
- 46 Err ERROR**  
This error code is presently not used.
- 47 No CIIL Present**  
This error message is generated when the MATE command CIIL is issued or bit switch 4 is set to the open on an instrument that does not have the MATE option installed.

## SECTION 4 MAKING MEASUREMENTS

### 4-1. INTRODUCTION.

This section contains information on specific types of measurements that can be made, and details regarding ordinary measurements and their accuracies. It is assumed that the reader is familiar with the basic front panel operation and the keystroke sequences. This section contains the following topics:

1. Sensor Calibration
2. Zeroing
3. Filtering
4. Measurement time
5. High frequency accuracy
6. Pulsed RF measurements
7. Chart recorder operation
8. Triggered operation and Settled Reading
9. Waveform sensitivity

### 4-2. SENSOR CALIBRATION.

Two types of calibration are associated with the 4300: instrument calibration and sensor calibration. The instrument (less sensors) must be calibrated using a DC source to ensure interchangeability of sensors (i.e., to ensure compatibility of all 4300's). The calibration procedures are covered in Section 6, Maintenance. Sensor calibration theory is discussed below.

Calibration data for up to 20 sensors is stored in nonvolatile RAM. Sensor calibration is of two types: linearity and high frequency cal factors. These are discussed below.

1. **14-Point Linearity Data.** For the case where the 30 MHz programmable calibrator is not installed, or when millimeter wave sensors are used, the linearity data (also referred to as AC reference frequency linearity data) is supplied with the sensor and is manually entered at time of purchase. Instruments shipped from the factory already have the data installed. Refer to Figure 4-1.

At the reference frequency (30, 50 MHz or 22, 33, 40, 60, or 94 GHz), each sensor has two gain factors for each range: upscale and downscale points. The upscale points are in the range of 5000, which is a gain correction factor. The upscale point is calibrated at the factory at about 70% of full scale. The downscale number is a second order type of correction at about 25% of full scale. Thus, for a diode sensor, (7 ranges) there are 14 points. For thermal sensors, there are 8 points. Ranges 0 and 1 share the same data points.

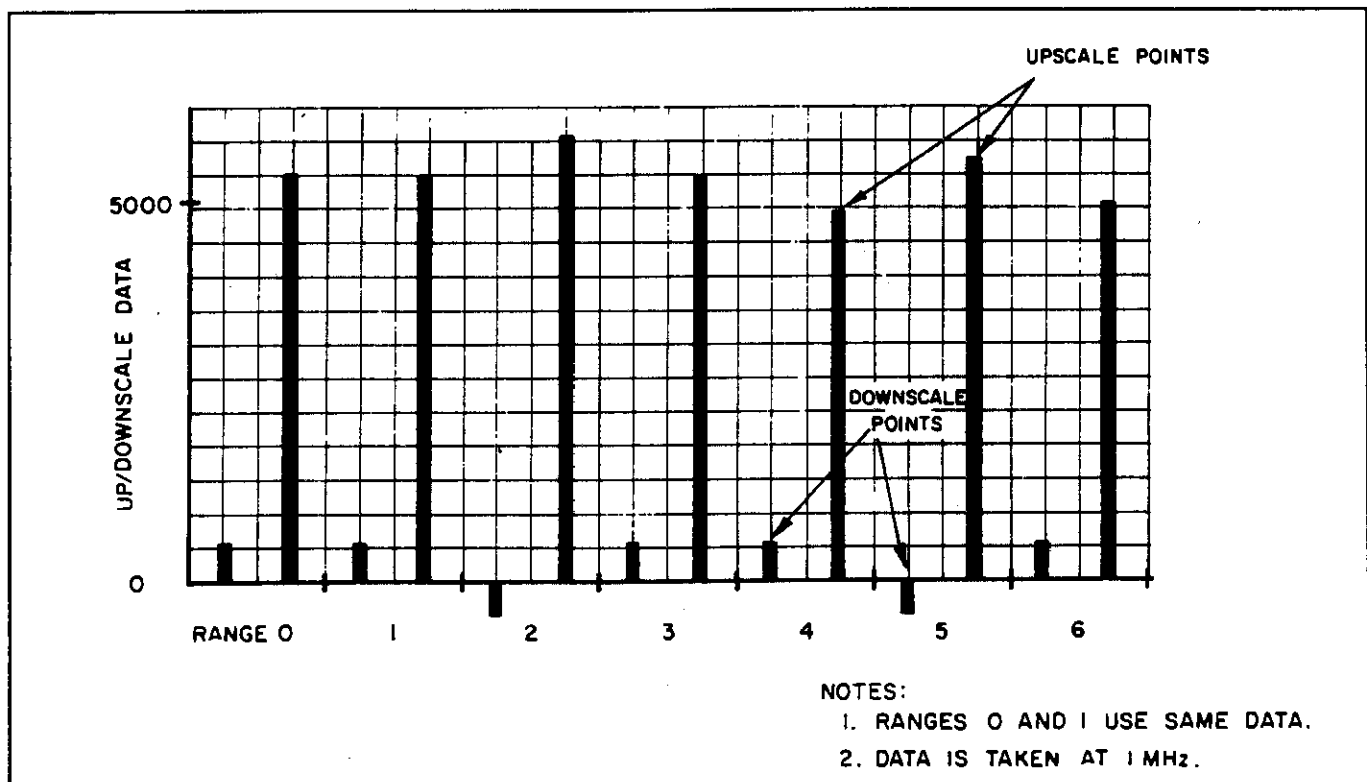

Figure 4-1. 14-Point Sensor Calibration

2. **Autocal Generation of Linearity.** If the 30 MHz Calibrator is to be used instead of the 14-Point linearity data, this function is simply executed by connecting the sensor to the calibrator and pressing AUTO CAL. The sensor type must be programmed and the sensor must be assigned to the applicable channel. Several points per range are calibrated in the peak transition regions of the sensor. The points may be as close as 1 dB apart in the peak and transition regions of the sensor. This is shown for a typical sensor in Figure 4-2. Not all points are shown. The power points are sensor dependent and are stored in the program.

Because of the close spacing, auto calibration reduces linearity errors to nearly zero. The 30 MHz Calibrator has its power points referenced to 0 dBm through an NIST traceable attenuation standard, good to .006 dB/10 dB (NIST does not identify attenuation at 50 MHz; when using the 14-point method of calibration the linearity calibration is done at 1 MHz. Other power meter techniques assume the linearity of the sensor and calibrate only at 0 dBm.)

The 30 MHz Calibrator limit is +20 dBm; therefore, for sensors whose top limit is above +20 dBm, the highest points in sensor's range will be extrapolated.

The Autocal routine also compensates for any channel

module inaccuracy. Therefore, if this Calibration mode is always used, DC calibration of the 4300 need not be done. The autocal data is stored in each channel module, not in the sensor data bank and is not transferable to other channels. If a sensor is assigned to another channel; it must be auto calibrated again.

Autocalibration of a sensor/channel adds correction on top of the "14-point" data if it has been previously stored. This increases the accuracy of the extrapolation of the sensors above +20 dBm; the top range(s) can be adjusted independently of the lower ranges.

3. **High Frequency Cal Points.** In addition to linearity data, there are high frequency points as shown in Figure 4-3. Calibration points covering the entire sensor frequency range are supplied with each sensor. Below 2 GHz the response is flat and the frequency cal points need not be entered.

Figure 4-3 shows data for 17 points; however, space for up to 80 points per sensor (sensors 1-6) is provided in the nonvolatile RAM (35 points for sensors 7-20). The frequency cal points need not be in equal frequency increments, however, the entry of data must be done in order of frequency. Generally a cal factor of 0 dB is entered at .01 GHz so that the unit may be operated below the first data point.

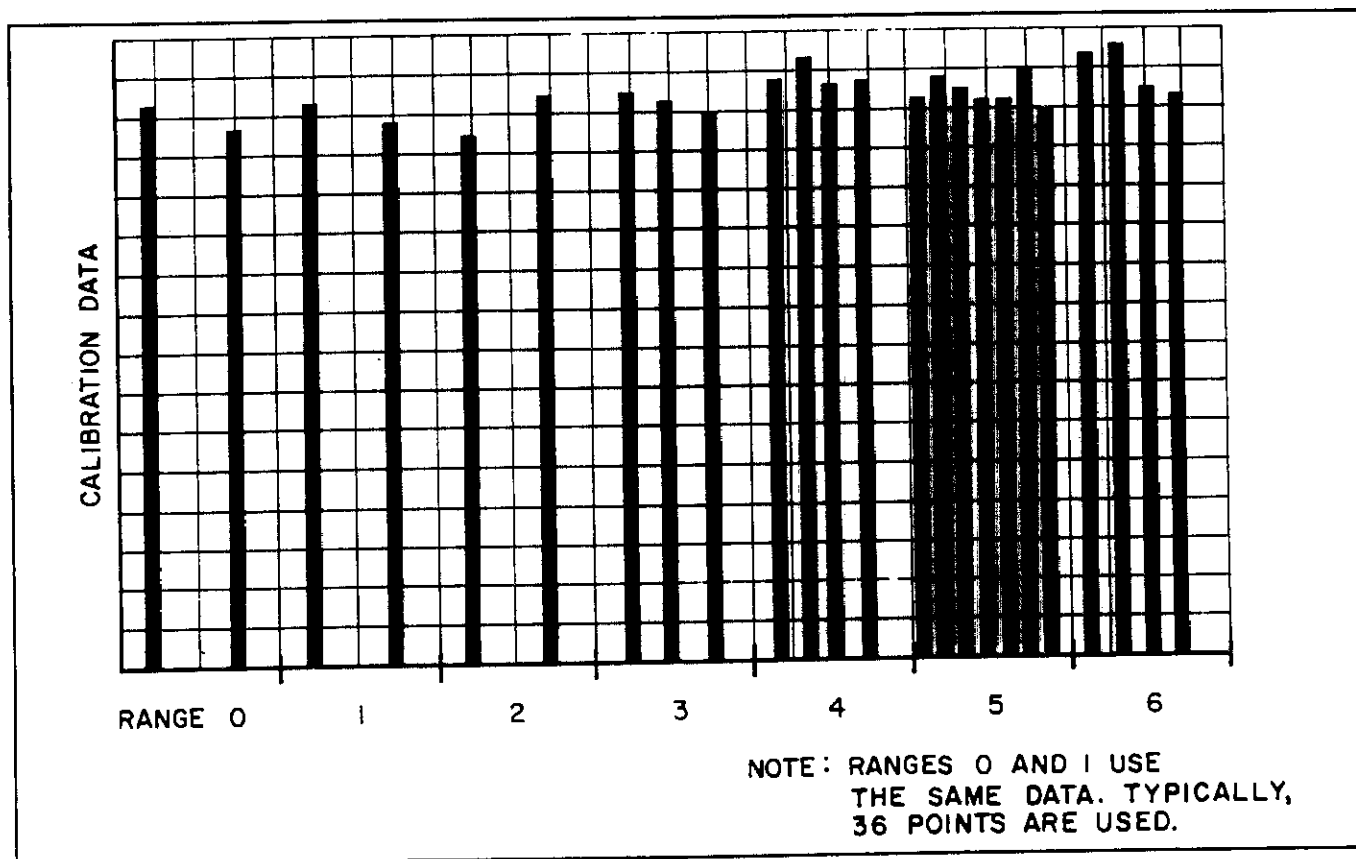

Figure 4-2. Autocalibration of Sensor



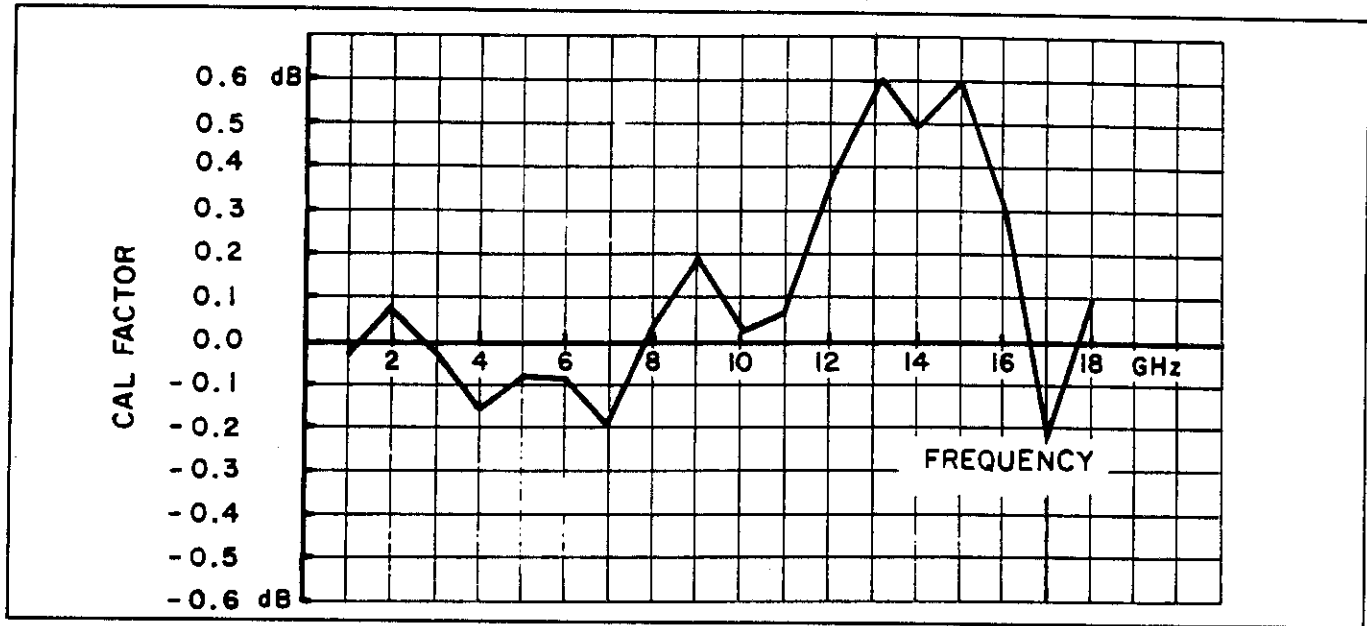

Figure 4-3. Typical High Frequency Sensor Calibration

During measurement, frequency points are linearly interpolated, and if a measurement frequency is entered outside the calibrated range of any sensor whose channel is displayed, an error message is generated.

4. **Sensor Data Entry.** The entry procedure for 14-point calibration and high frequency calibration is initiated by pressing the SENSOR ENTRY key. The instrument will prompt the user for information. See the Operation section for details, however, the procedure should be self evident by following the prompts. Information is entered in the following sequence: sensor number (1-20), type, serial number, upscale points (scroll can be used to bypass these), downscale points, and the high frequency cal factors. ESCAPE can be pressed at any time to exit the routine.

#### 4-3. ZEROING.

The automatic zeroing routine takes measurements on the bottom 5 ranges and applies these as correction factors on subsequent measurements. Offsets in the sensor and input amplifiers are linearly corrected in the internal software. Offsets on the top ranges are below .02% of full scale and do not need correction.

The input power to the sensor must be removed before the zeroing function is executed or an error message will be generated. The 4300 will do the zero however, if the signal is less than full scale on Range 0. This feature provides for a great deal of offset capability from temperature, effects, etc., without rezeroing the input amplifier hardware.

For full accuracy at low signal levels, power must be removed from the sensor several seconds before zeroing to allow the sensor to settle. This is especially true if a large signal has been applied to the sensor in the previous 20 seconds or so, because of the dielectric absorption of the capacitors in diode sensors, and because of the thermal retention in thermal sensors. The error resulting from different input conditions can be determined by examining Figure 4-4, Diode Sensor Decay and Figure 4-5, Thermal Sensor Decay. The curves show the decay of measured power after a large signal has been applied. The typical error that can be expected by zeroing too quickly is equal to the offset power at the time of zeroing.

The 4300 waits for 2 seconds when the zero key is pressed before zeroing to account for typical decay conditions and typical accuracy requirements. The user must add a delay according to the system requirements when the sensors are used over a wide dynamic range. For example, if it is determined from the application that 5 seconds is required from power off to the zero operation, then the user should wait 3 seconds after removing power before pressing ZERO.

When the chart recorder output is used as a hardware zero output to disable the source, this TTL signal goes low immediately. The overall zero sequence is as follows:

- a. Waits for 500 msec.
- b. Makes a trial measurement to check for no signal, displaying "CHECKING" (an error message will be indicated if a signal is present.)
- c. Waits 2 seconds for the sensor to settle, displaying "SETTLING".

Section 4  
Making Measurements

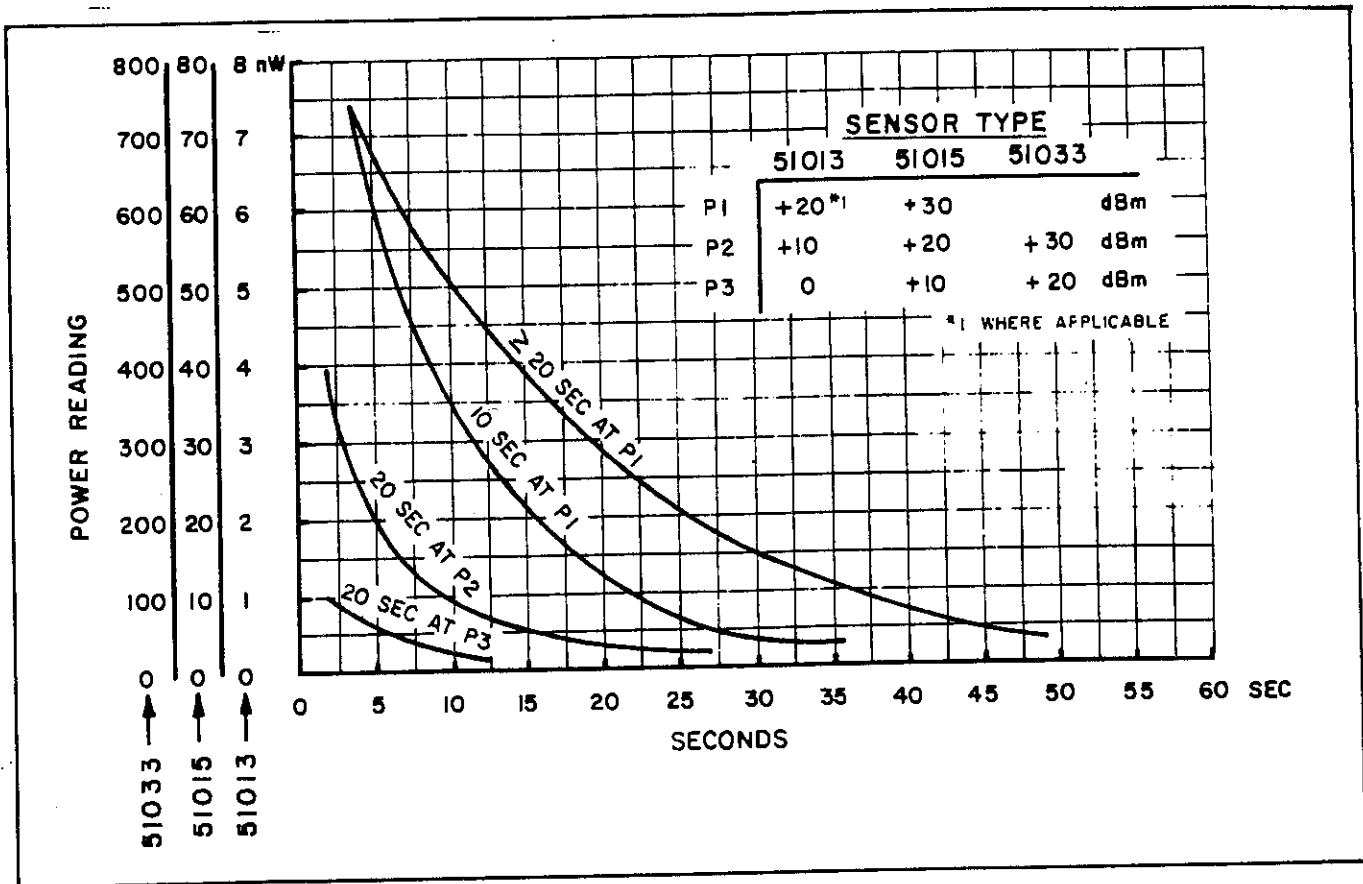

Figure 4-4. Diode Sensor Decay

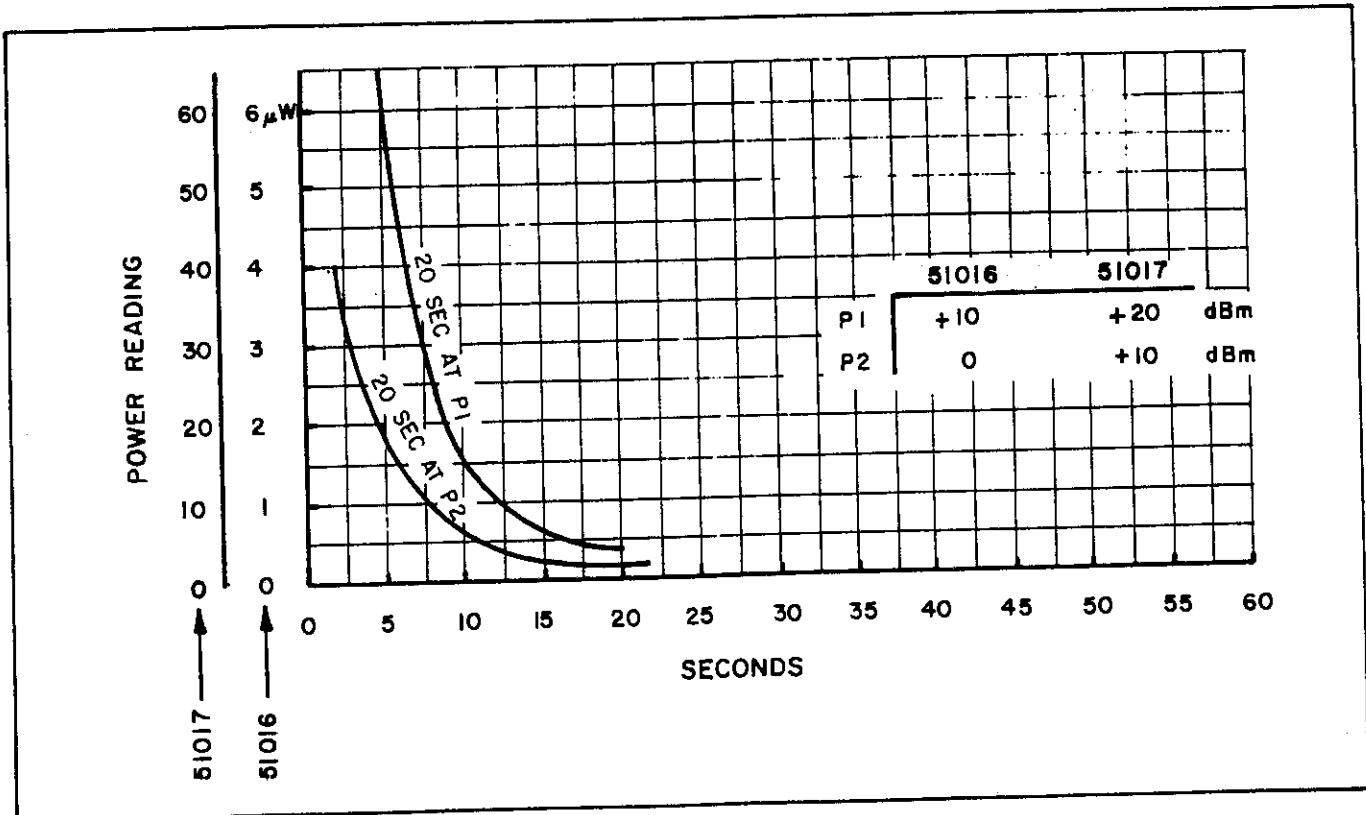

Figure 4-5. Thermal Sensor Decay

d. Zeros ranges 4 through 0 in that order, displaying "ZEROING".

The zeroing/averaging time on each range has been optimized as a function of the filter length for speed and accuracy. The total zeroing time takes about 12 seconds for the default filter lengths, 5 seconds for minimum filtering (20 msec all ranges), and 30 seconds for maximum filtering. If desired, the filter length can be modified prior to zeroing and set back to its original value after zeroing, however, this is somewhat counterproductive since when long filtering is used for measurement, then long filtering is usually desired for zeroing. There is the case, however, where power levels are at a medium level and long filtering is used (for filtering of source variations) and it is not necessary to use a long filter for zeroing. This would be a reason to implement a temporary filter decrease during zeroing.

Zeroing should be done whenever the sensor has drifted a significant amount with respect to the signal being measured. For large signals, this may be once every several hours if at all. For very small signals, it is recommended that zeroing be done just before a measurement.

**Dynamic Range.** The Hold Range mode is useful when it is known that the signal will vary over a certain limited range. In this mode, the decimal point and units will remain fixed. The dynamic range of this mode is limited by the zero offset and the resolution, as shown in Figure 4-6. **Extended Hold Range Mode.** It can be seen that the useful dynamic range of each range is about 20 dB if the error is to be kept less than 0.1 dB.

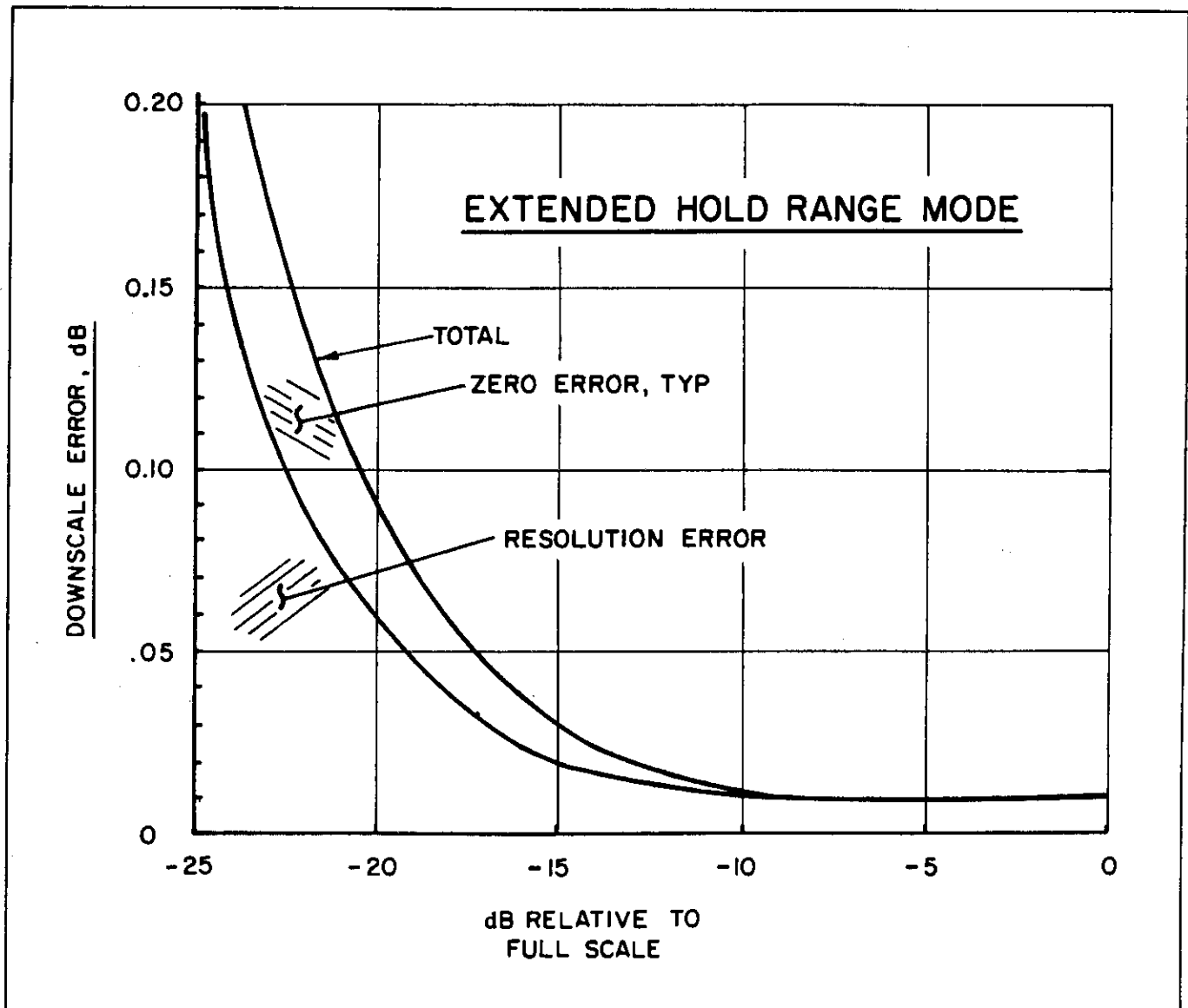

Figure 4-6. Extended Hold Range Mode

Section 4  
Making Measurements

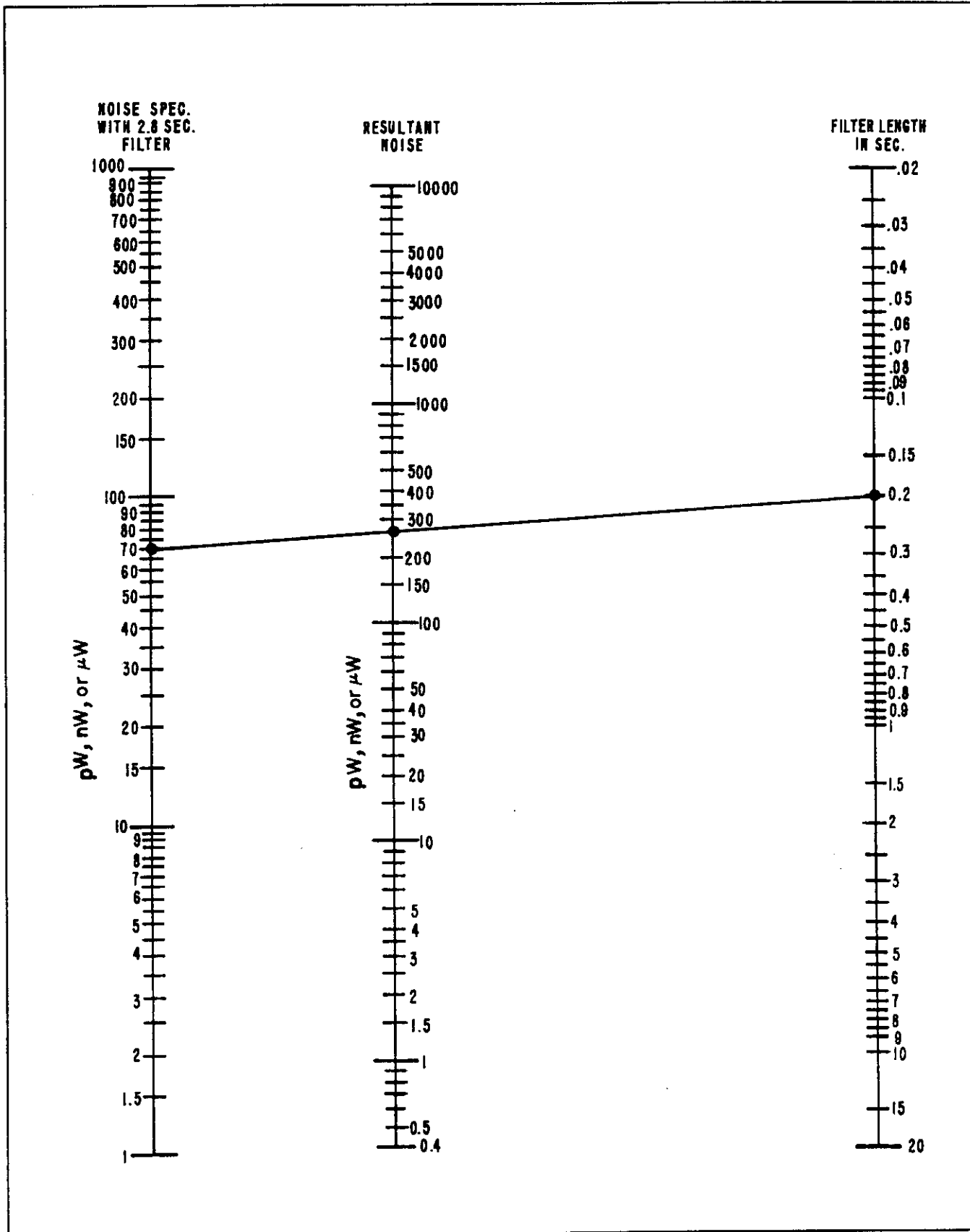

Figure 4-7. Noise Reduction for Universal Channels

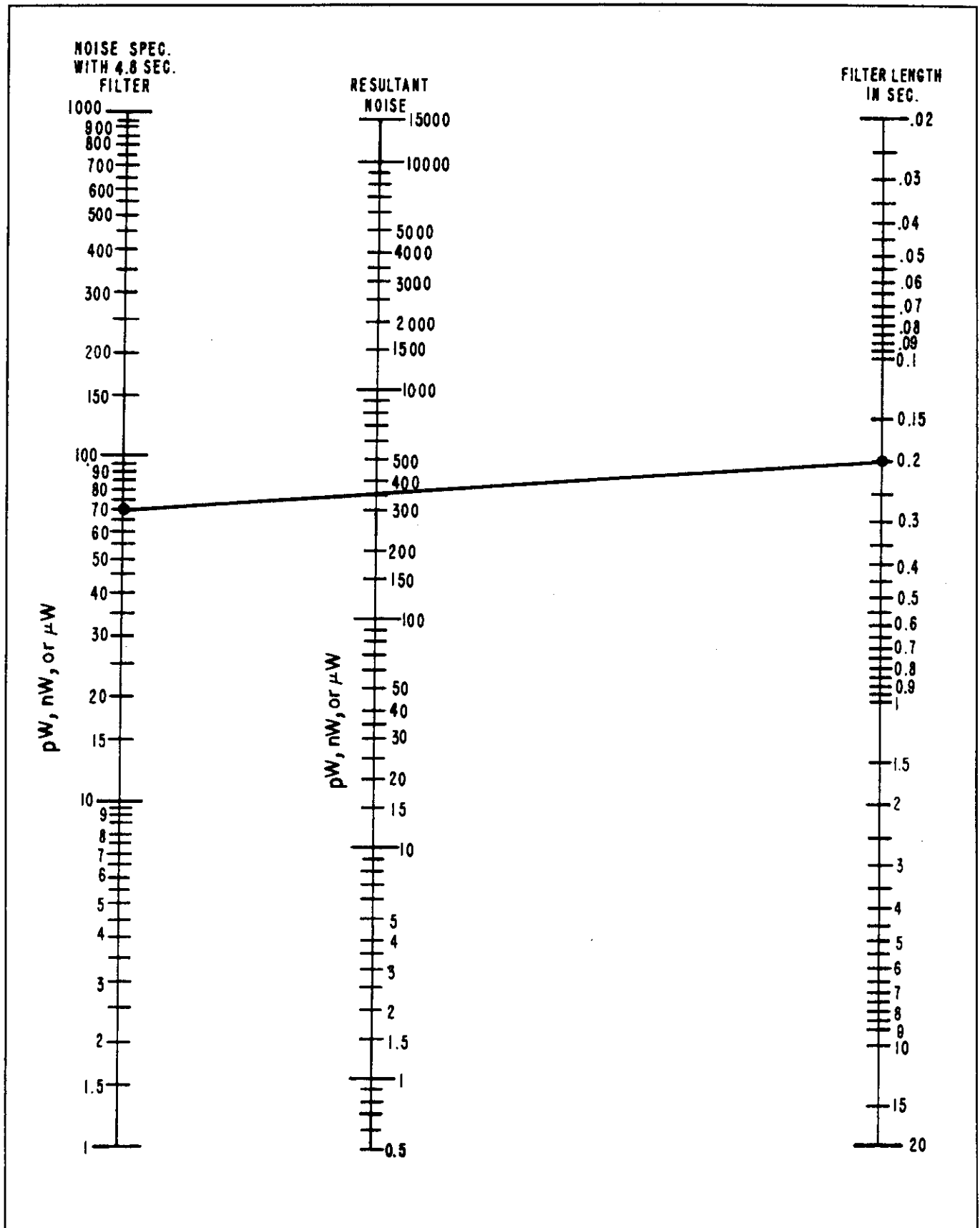

Figure 4-8. Noise Reduction for Thermal Channels

4-4. FILTERING AND NOISE.

The 4300 employs digital filtering, or averaging of measurements to reduce the noise floor of the instrument and to stabilize the measurements. Selectable averaging of up to 1000 samples is used, at an input channel sampling rate of 20 msec, which corresponds to a maximum filter time of 20 seconds. The minimum filtering is one sample or 20 msec. Alternatively, the 4300 can be programmed to use default filter lengths which are a function of the range. These numbers are optimized for speed and low noise under general conditions. Refer to Table 4-1. Default Filters for a listing of the default lengths.

TABLE 4-1. DEFAULT FILTERS

| Range | Universal Input Channel | Thermal Input Channel |
|-------|-------------------------|-----------------------|
| 0     | 2.8 Sec                 | 4.8 Sec               |
| 1     | 0.8                     | 1.8                   |
| 2     | 0.3                     | 0.6                   |
| 3     | 0.06                    | 0.3                   |
| 4     | 0.06                    | ---                   |
| 5     | 0.06                    | ---                   |
| 6     | 0.06                    | ---                   |

The filtering technique used is called digital pipeline filtering, also referred to as circular filtering or moving average filtering. The displayed power is simply an equally weighted average of the last x seconds worth of samples, where x is the filter length in seconds. For purposes of noise and settling time, the number of samples is not important, but rather the time is. That is, if a 3 second filter is used, the noise is the same whether 60 or 600 samples are taken in that interval, providing that the samples are taken above a certain rate. Therefore, the 4300 filter selection is done in milliseconds rather than the number of samples.

The bottom end sensitivity is limited by sensor noise. An RMS noise specification is valid since the sensor and amplifier noise are band limited and Gaussian. The noise level, specified in picowatts at a certain filter length, is sufficient to calculate the error due to noise at any signal level, for any filter, as shown below.

1. **Noise Reduction.** The amount of noise reduction that can be realized has no theoretical limitation, except that drift enters the picture at filter lengths over 20 seconds. The digital filter has a bandwidth and roll-off curve just as any filter does; the bandwidth can be reduced arbitrarily. The effective noise bandwidth is  $0.469/t$ , where t is the filter length. For example, with a filter length of 4 seconds, the equivalent noise bandwidth is 0.12 Hz.

Figures 4-7 and 4-8 are nomographs showing the noise reduction that applies to various filter lengths, given the sensor noise with 2.8 second filtering (diode sensors) or 4.8 second filtering (thermal sensors). These filter times are used to specify the noise of diode and thermal sensors.

The noise power is inversely proportional to the square root of the filter length. Normally, noise power varies directly with filter bandwidth; but, since power sensors are square law devices (detected voltage is proportional to power), the noise power is proportional to the square root of bandwidth. This can be demonstrated with noise measurements. At very low filter lengths, however, (less than 60 mSec), the noise does not increase without bound for all sensors because the input amplifier noise is restricted with hardware filters to a few Hertz. This additional filtering is not shown in the nomograph.

2. **Error Computation.** Since the noise is Gaussian, both before and after filtering, statistics show what level of confidence factor can be associated with a given reading. (At medium or high power levels, the confidence factor is essentially unity.) Figure 4-9 shows a typical set of samples and a typical error band specification of 2 sigma. 95.5% of the readings will fall within  $\pm 2$  sigma.

Figure 4-10 shows the confidence factor for other error bands. The error band is expressed in pW, no matter what the power level is. (The percentage error band can also be calculated and is shown below.) The RMS noise is taken from the sensor specifications and modified as necessary for filter lengths other than 2.8 seconds (diode sensors) or 4.8 seconds (thermal sensors). Knowing any two of the three parameters (error band, RMS noise, and confidence factor), the third can be computed.

As an example, if the sensor RMS noise is 65 pW, and the confidence factor is to be 95.5%, then the error band is 130 pW, single sided ( $\pm 130$  pW). If this were the case, at a measurement level of 1300 pW, the percent error band would be 10% or about  $\pm 0.44$  dB.

**NOTE**

The noise specifications given for the thermal sensors is based on the use with the 4312 Thermal Input Module. When the Universal Module is used, the noise is increased by 5 dB.

3. **Noise Error Examples.** Figures 4-11 and 4-12 show the computed error for the 51013 diode sensor at different power levels, for 2.8 and 10 second filters. To achieve these results, the sensor must be at a stable temperature and zeroing must be done immediately before the measurement is taken.

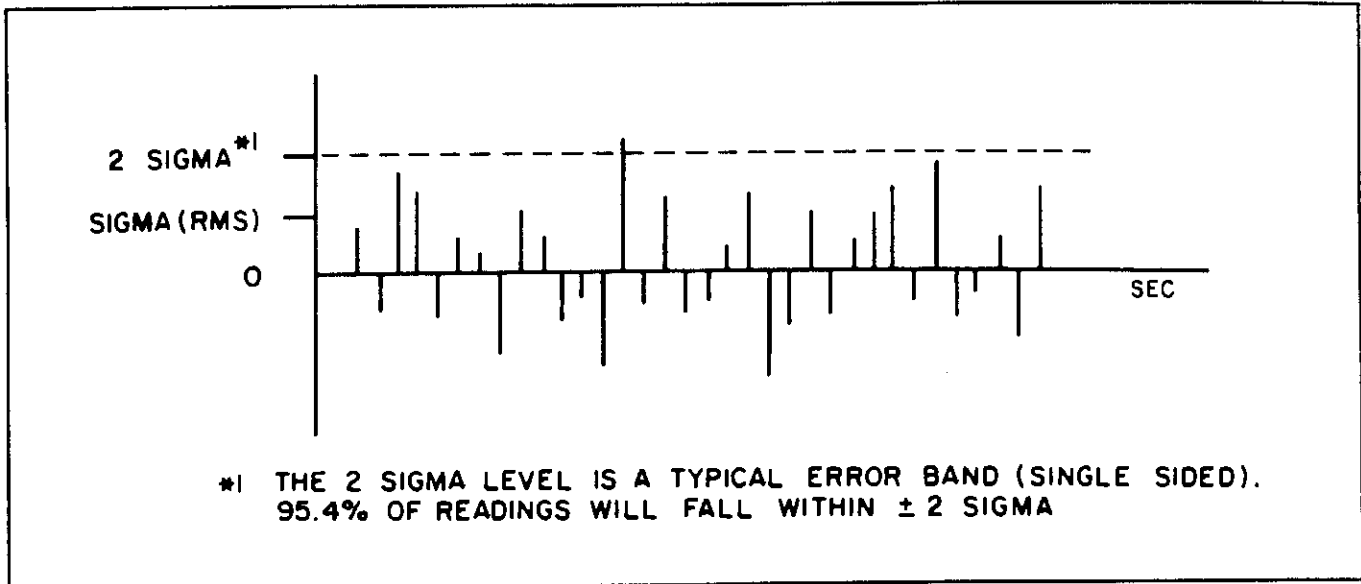

Figure 4-9. Typical Error Band Specification

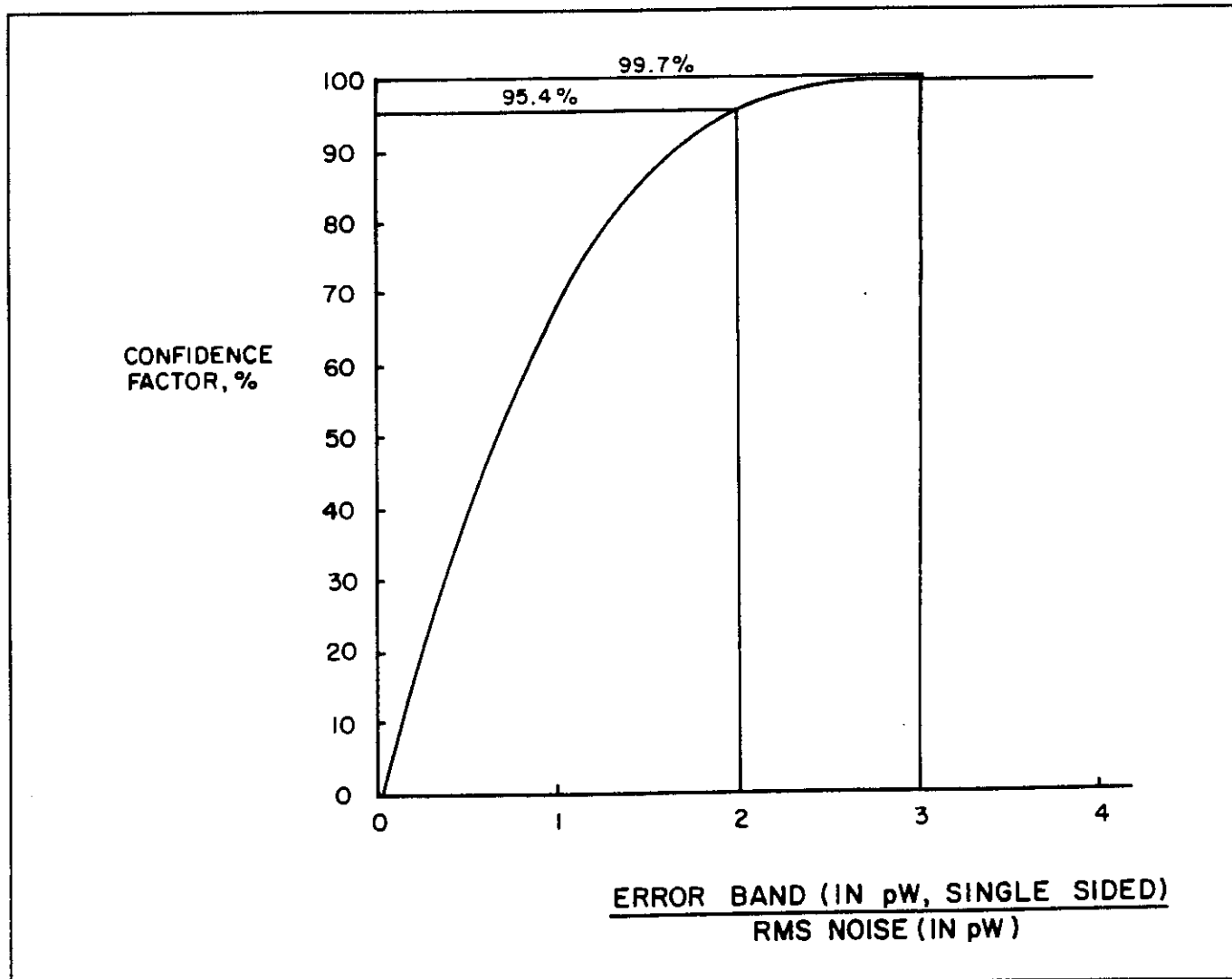

Figure 4-10. Probability of Falling Within an Error Band

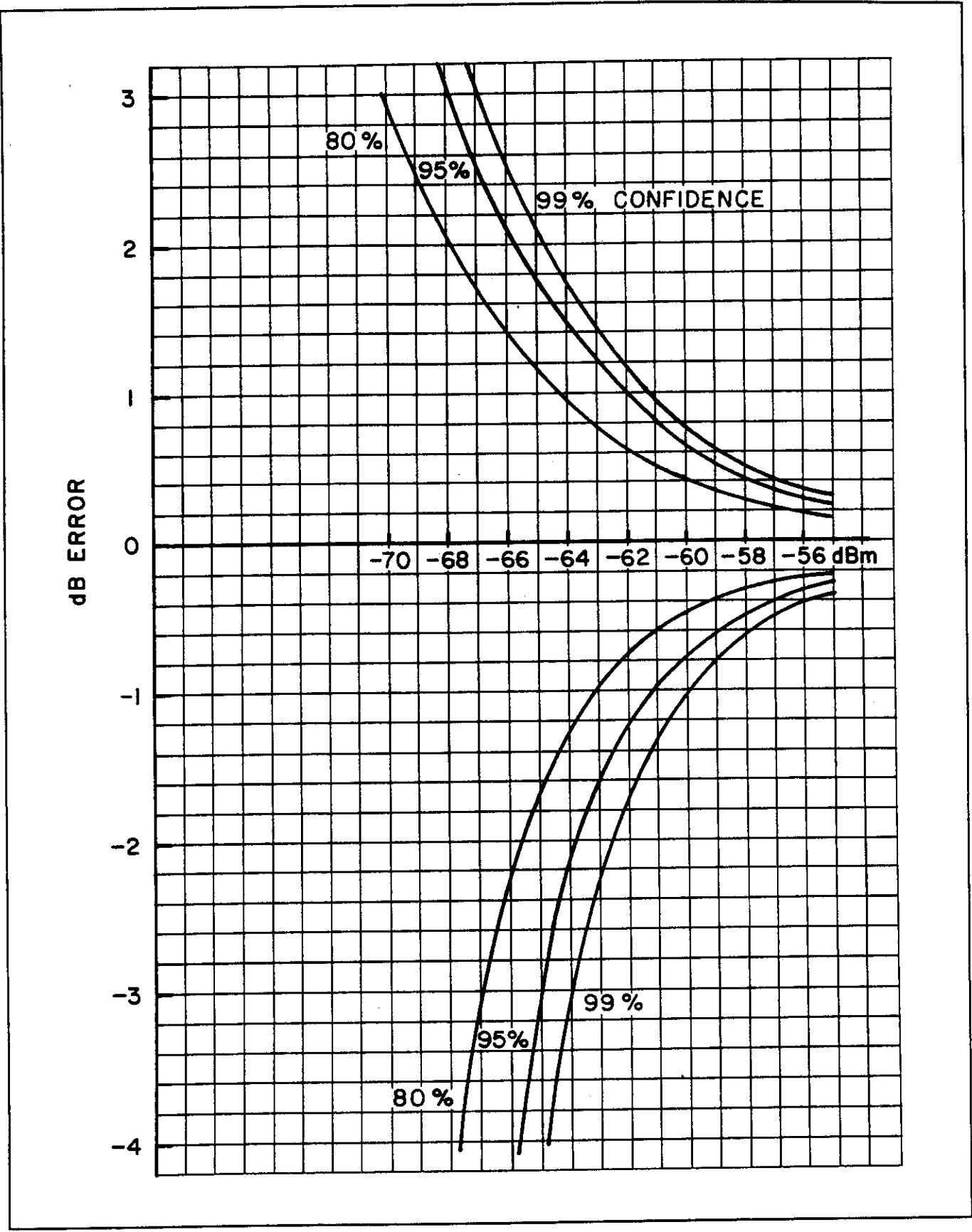

Figure 4-11. 51013 Sensor With 2.8 Second Filter



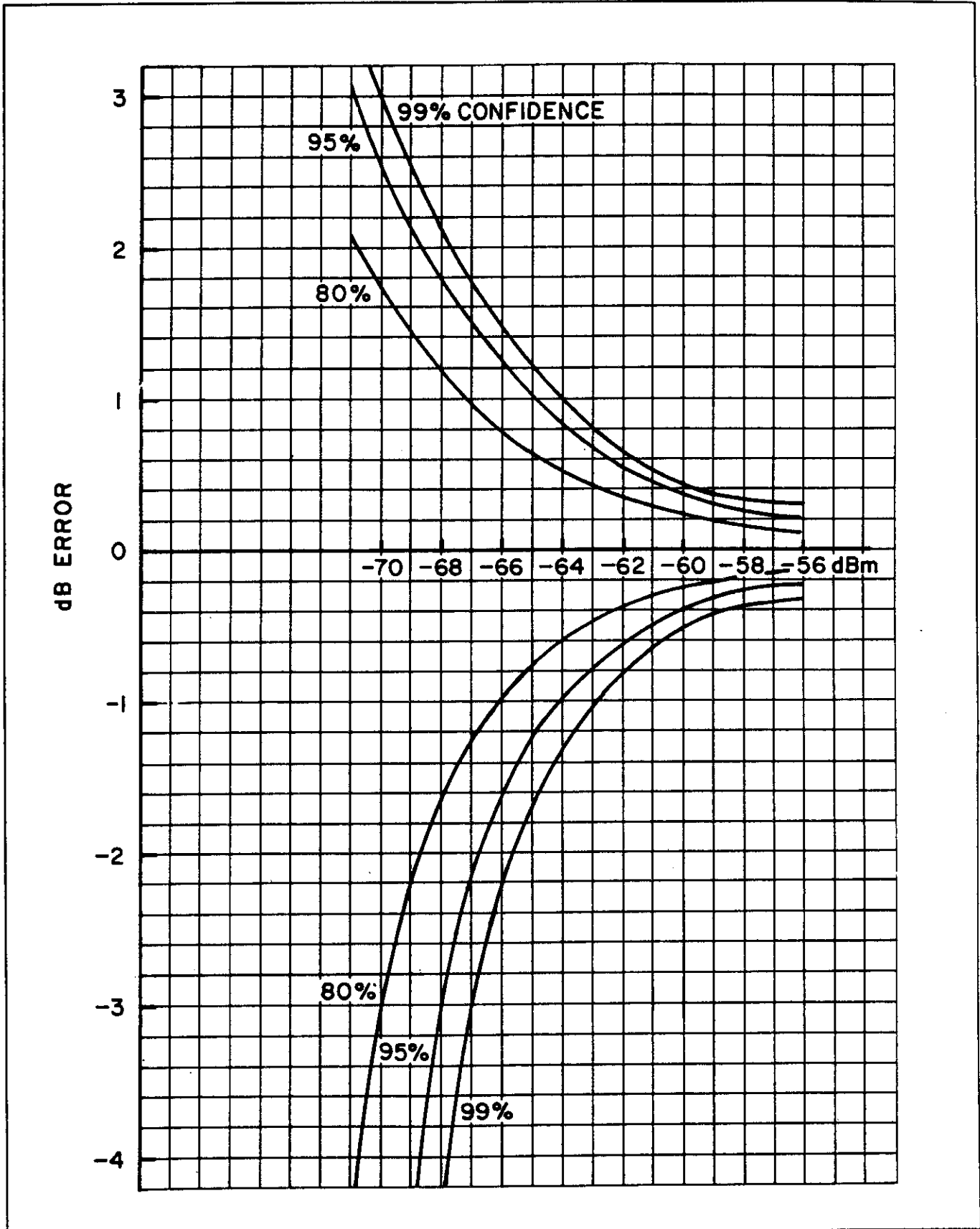

Figure 4-12. 51013 Sensor With 10 Second Filter

4. **Integration of Power.** With long filtering, panel readings may seem erroneous because the filter has not been cleared. For example, with a 20 second filter, if a 2 second RF pulse is applied, the display will indicate a nonzero level for 18 seconds after the pulse has gone away. Additional pulses will be integrated along with the first until, by the process of selective deletion, the pulses are removed one at a time from the filter. Actually, measurement samples are deleted, not the pulses, giving rise to a ramping effect at the display/output. This is shown in Figure 4-13. In all senses, the filter is a simple integrator. This scheme is not the best if one considers noise rejection versus bandwidth alone, however, bandwidth is not a quantity of direct interest here. For the best compromise of noise rejection and settling time, this method is ideal and has the additional benefit that the output ramp response is easy to interpret, and the display settles abruptly when filtering is complete.

5. **Clearing.** When long filters are used it may become troublesome at times to wait for the filter to clear. Clearing can be accomplished by changing the filter length to any different value and then resetting it. Alternatively, if the input power is sufficient to keep the unit on range 1 or higher, pressing the zero key will clear the filter since the zero routine begins and ends by clearing, and with a signal input the channel will not actually go through the zero operation. The first method is recommended over the GPIB bus. However, with bus operation most of the trigger modes clear the filter at trigger time; see TRIGGERING.

6. **Partial Results.** The measurement time is affected by the filter since valid readings to within a certain error band can only be obtained when the filter is full. However, in free run mode, if the filter has been cleared, the data is available at reduced accuracy immediately after the first 20 mS sample. That is, the filter uses the number of samples as a divisor when computing the average, and the bus output/display does not ramp but instead "homes in" on the result as the samples accumulate.

#### 4-5. MEASUREMENT TIME.

1. **Step Response.** The measurement time from a power input step is the sum of the overhead time and the length of the digital filter, where the overhead time is defined to be the time delay due to the sensor response time and the measurement software (processing). The overhead time is given below for certain conditions. The measurement time due to a step response is generally associated with the triggered modes of operation, but applies to free run measurements as well.

In theory, the total measurement time is a bit less than the arithmetic sum of the overhead time and the digital filter (it is the convolution of the two) but for most purposes the simple sum will do.

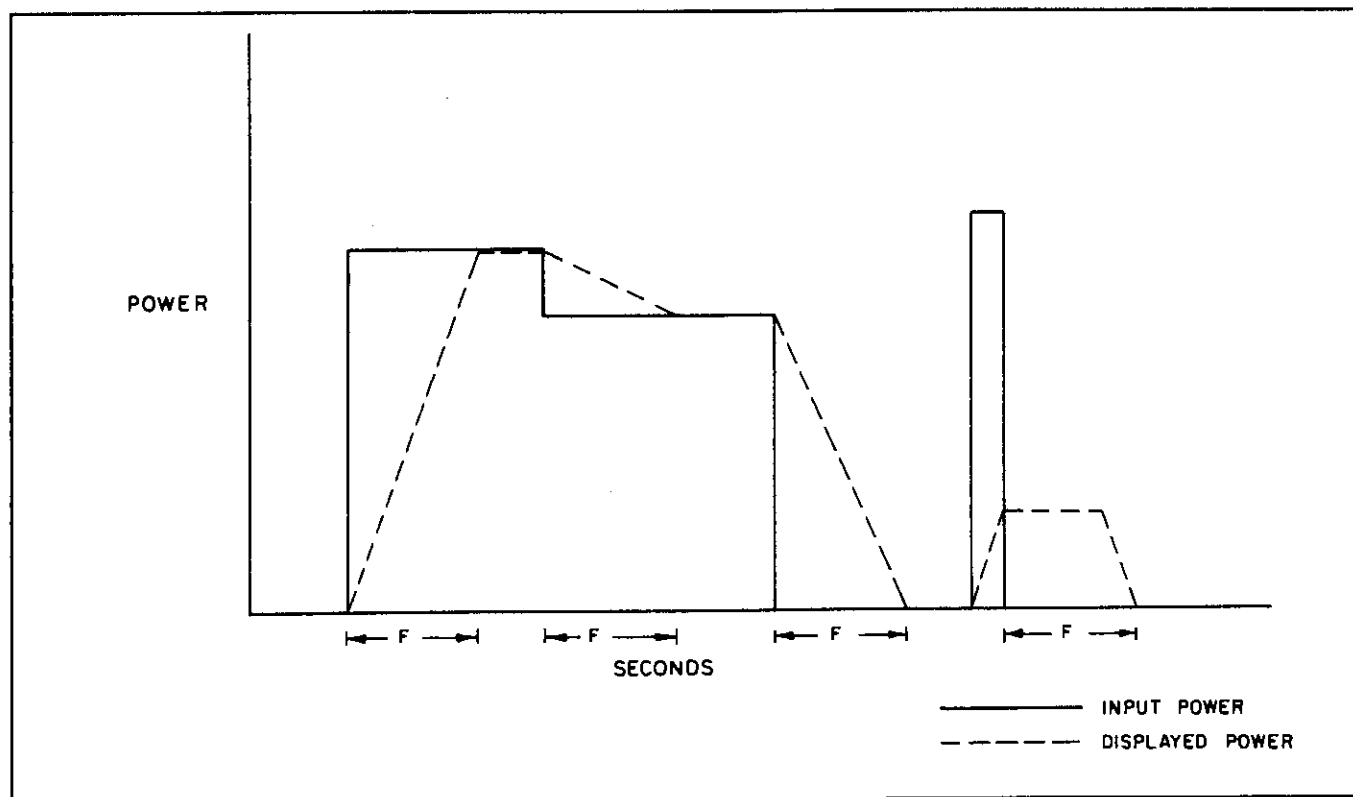

Figure 4-13. Integration of Power

2. **Continuous Response.** Regardless of the overhead time or the digital filter length, the 4300 will output readings at a rate of about 25 mS per channel (30 mS max; 180 mS for six channels) over the bus with the display nonoperating. As the sensor and the digital filter settle, the 4300 readings will ramp up or down at that rate. The continuous time is generally associated with the free run modes of operation (sweeping applications).

3. **Overhead Time.** The overhead time is <200 mS for diode sensors and <450 mS for thermal sensors. This applies for the following conditions:

- Settling to 99% or .04 dB of the final power.
- Power step of 10 dB.
- Range does not change (hold range as applicable).
- Digital filter set to minimum (20 mS, which is a filter length of one sample).

The power step may be upward or downward. Smaller power steps will decrease this time a bit. Larger power steps in the downward direction will increase the time significantly; a 40 dB downward step will take several seconds to settle to .04 dB.

4. **Digital Filter.** The digital filter is a moving average, or pipeline filter which simply integrates the readings over the last x seconds where x is the filter length. In the free run mode (Mode 0), a step input to the filter will produce a linear ramp at the output, terminating when the filter is full. In

the triggered mode (Mode 3), the output data is not updated until the filter is full, see "Triggered Operation and Settled Reading" in this section.

5. **Default Filters.** Although any filter length may be chosen from 20 mS to 20 seconds, default filter lengths for each range are programmed in for optimum general conditions, as shown in Table 4-1.

For diode sensors, the range breakpoints are roughly in 10 dB steps, with the range 0 to 1 breakpoints at about -54 dBm.

For thermal sensors, the breakpoints are at even 10 dB steps (0, -10, -20, etc.) with the highest point at the top of the sensor's specified range.

6. **Settled Reading Measurement Time.** In the settled reading modes (Modes 3 and 5), the output data updates are held off until the measurements have settled. See Triggered Operation and Settled Reading in this section. Typical measurement times from a power step to a settled bus measurement are shown in Table 4-2.

#### 4-6. HIGH FREQUENCY ACCURACY.

Power measurements, particularly at high frequencies, have a number of uncertainties, most of which arise from imperfect SWR's. If all power sources and power

TABLE 4-2. 4300 SETTLING TIME TO 1%

|                                                                   |     | (Free Run Settled Mode) |      |      |      |      |      |      |     |
|-------------------------------------------------------------------|-----|-------------------------|------|------|------|------|------|------|-----|
|                                                                   |     | End Level dBm           |      |      |      |      |      |      |     |
|                                                                   |     | +20                     | +10  | 0    | -10  | -20  | -30  | -40  | -50 |
| S<br>T<br>A<br>R<br>T<br>I<br>N<br>G<br><br>L<br>E<br>V<br>E<br>L | +20 | ---                     | 0.25 | 0.3  | 0.35 | 0.4  | 0.8  | 3.5  | 10  |
|                                                                   | +10 | 0.25                    | ---  | 0.25 | 0.35 | 0.4  | 0.45 | 1.8  | 8   |
|                                                                   | 0   | 0.25                    | 0.3  | ---  | 0.3  | 0.35 | 0.35 | 1.1  | 2.5 |
|                                                                   | -10 | 0.3                     | 0.3  | 0.3  | ---  | 0.3  | 0.35 | 0.65 | 1.5 |
|                                                                   | -20 | 0.3                     | 0.35 | 0.3  | 0.3  | ---  | 0.3  | 0.6  | 1.2 |
|                                                                   | -30 | 0.35                    | 0.35 | 0.3  | 0.3  | 0.3  | ---  | 0.5  | 1.1 |
|                                                                   | -40 | 0.4                     | 0.45 | 0.4  | 0.4  | 0.4  | 0.4  | ---  | 1.1 |
|                                                                   | -50 | 0.5                     | 0.45 | 0.45 | 0.45 | 0.4  | 0.4  | 0.55 | --- |
| dBm                                                               |     |                         |      |      |      |      |      |      |     |
| *Numbers are in seconds and are typical.                          |     |                         |      |      |      |      |      |      |     |

Section 4  
Making Measurements

meters had impedances that were resistive and equal to  $Z_0$  (the characteristic impedance of the measuring system), most problems would disappear. The incident, dissipated, and maximum available powers would all be equal, and the indicated power would differ only by the inefficiency of the power sensor in converting all of the dissipated power to indicated power. Tuning eliminates most of the SWR effects, but is cumbersome and is seldom done. The use of attenuator pads can mask imperfect SWRs, as can the use of a directional coupler to level the source and reduce its reflection coefficient to a value equal to the directivity factor of the coupler. The 51015 and 51033 sensors have precision built-in attenuators which improve the SWR over a straight sensor.

When the complex impedances of both an imperfect source and a power sensor are not known, but the maximum SWR of both is known, the maximum positive and negative uncertainties of the measured power,  $P_m$ , can be determined from Figure 4-14. If the SWR of the source is known to be 1.2 and the SWR of the power sensor is 1.25, we can see that from Figure 4-14 the uncertainty is 2%.

The measurement uncertainty can be calculated by:

$$U = 2 \rho_L \rho_s$$

or

$$U(\%) = 200 \times (\rho_L \times \rho_s)$$

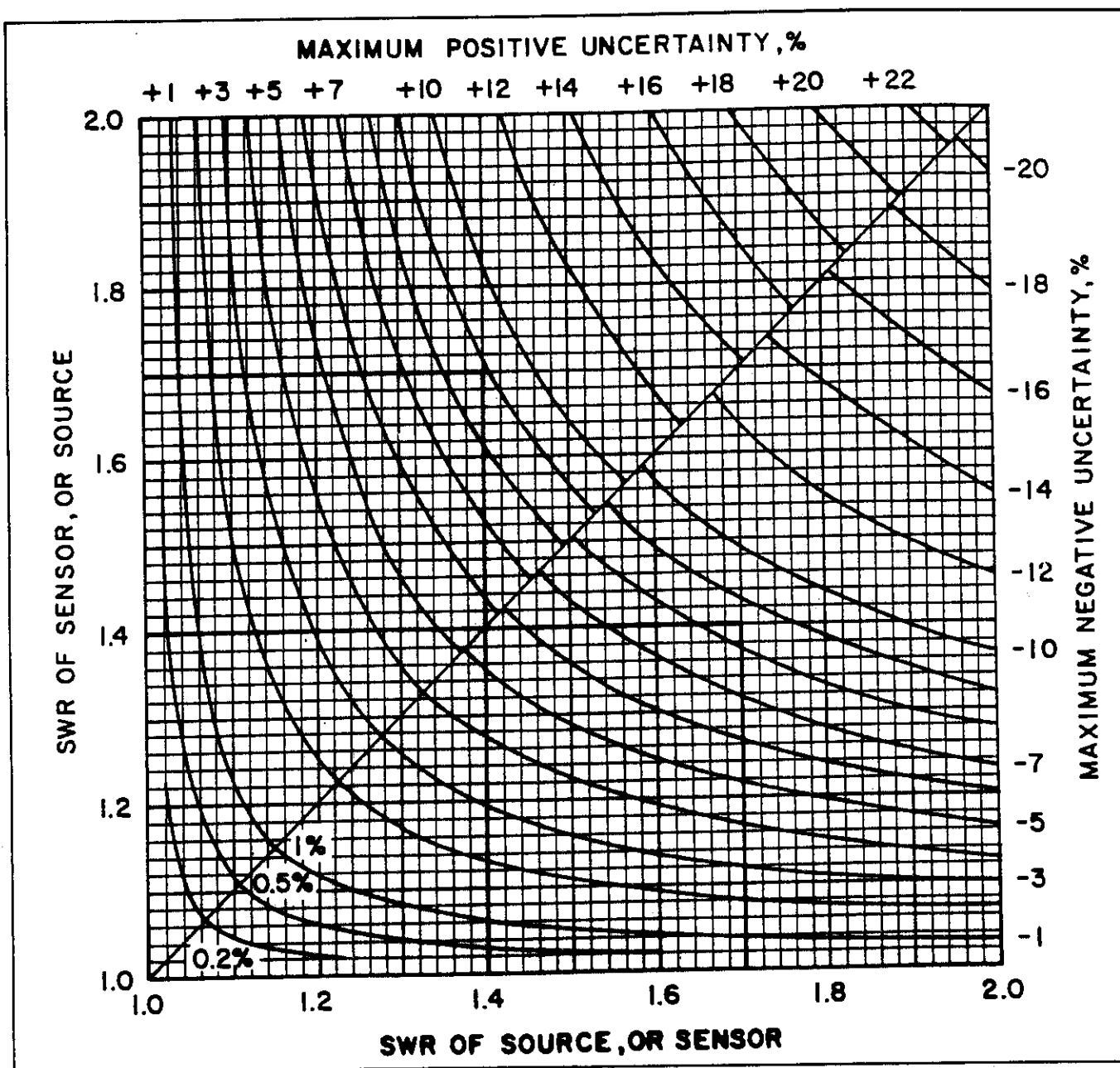

Figure 4-14. Mismatch Uncertainties Chart

where  $\rho_L$  and  $\rho_S$  are the reflection coefficients of the load and source. The reflection coefficients are related to the SWR by:

$$\rho = (SWR - 1) / (SWR + 1)$$

#### 4-7. PULSED RF OPERATION.

Although the 4300 is an average responding power meter, for rectangular pulsed RF, if the duty cycle is known, it can be entered and the 4300 will calculate the pulse power (sometimes referred to as peak power; for rectangular envelopes the pulse and peak powers are the same).

The computation is done in the 4300 by dividing the power measurement by the duty cycle. This technique is valid for thermal sensors over their entire range, and allows very high pulse powers to be measured. For diode sensors, this technique is valid in the RMS region of the sensor only, however, in the 4300, the RMS region has been extended by 10 dB with software, by taking advantage of the known repeatability of the sensors.

1. **Thermal Sensors.** Figures 4-15 and 4-16 show the regions of valid duty cycle and pulse power that apply to the thermal sensors. As the duty cycle decreases, the average power decreases for a given pulse power and the noise becomes a limitation. Also, there is a pulse power overload limitation, which applies no matter how short the duty cycle is. Lastly, the average power rating of the sensor cannot be exceeded (there is some headroom between the measurement limitation and the burnout level of the sensor).

Since the detection process in thermal sensors is heat, thermal sensors can handle pulse powers that are two orders of magnitude larger than their average power. This makes them ideal for the purpose. Care must be taken not to exceed any of the sensor ratings; see the sensor specifications for more details. The minimum repetition rate for thermal sensors is 100 Hz, although this is a soft limitation.

2. **Diode Sensors.** Figure 4-17 shows the valid operating region for the 51013 diode sensor. For the 51015 and 50133 sensors, add 10 and 20 dB to the y axis, respectively. As mentioned previously, the operating region has been extended 10 dB above the normal RMS region of the sensor with internal math and correction curves. As with thermal sensors, the bottom end measurement is limited by noise, getting worse as the duty cycle decreases. At the top end, the limitation is on pulse power because even a very short pulse will charge up the detecting capacitors. The error for various duty cycles and pulse powers is shown. As the duty cycle approaches 100%, the error decreases to zero because the 4300 is shaped for CW (continuous wave) RF. The burnout levels must be observed. The burnout level for diode sensors is the same as for pulsed and CW waveforms.

3. **Duty Cycle Operation.** The procedure for thermal and diode sensors is shown below. Duty cycle may be applied to channels independently, by entering the duty cycle in single channel mode. Then if desired, multichannel mode may be executed. If all 6 duty cycles are the same, duty cycle can be entered from multichannel mode. The following keystrokes apply:

DTY CY, nn.nn, ENTER  
(nn.nn is the duty cycle . . in percent)

In single channel mode, the display indicates average and pulse power and duty cycle. Additionally, with diode sensors, a message indicates what region the sensor is in (RMS, Transition, or Peak). The peak region is invalid and this is displayed as an error message. Disabling is accomplished by pressing DSBL.

TABLE 4-3. CHART RECORDER OPERATION

| <u>Parameter Selector</u> | <u>Performs the Function</u>                                                                                               |
|---------------------------|----------------------------------------------------------------------------------------------------------------------------|
| 0                         | Sets the bottom endpoint in dBm corresponding to 0 V (applied in dBm/dBr/dB modes only).                                   |
| 1                         | Sets the top endpoint in dBm corresponding to 10 V (watts or dBm/dBr/dB modes).                                            |
| 2                         | Assigns the summation result to one of 6 channels, overriding the normal operation of that channel's output.               |
| 3                         | Turns the chart recorder off.                                                                                              |
| 4                         | Sets the recorder to indicate when the channel is zeroing.                                                                 |
| 5                         | Sets the recorder to indicate when the high or low limits have been exceeded.                                              |
| 6                         | Sets the recorder to represent the raw data (display still in watts or dBm/dBr/dB).                                        |
| 7                         | Returns the recorder to measurement mode (takes it out of modes 3, 4, 5, or 6). Used to terminate above entries. See text. |

#### 4-8. CHART RECORDER OPERATION.

The chart recorder output on each channel is a 0 to 10 V DC output proportional to power in the Watts mode and proportional to dB in the dBm and dBr modes. In the

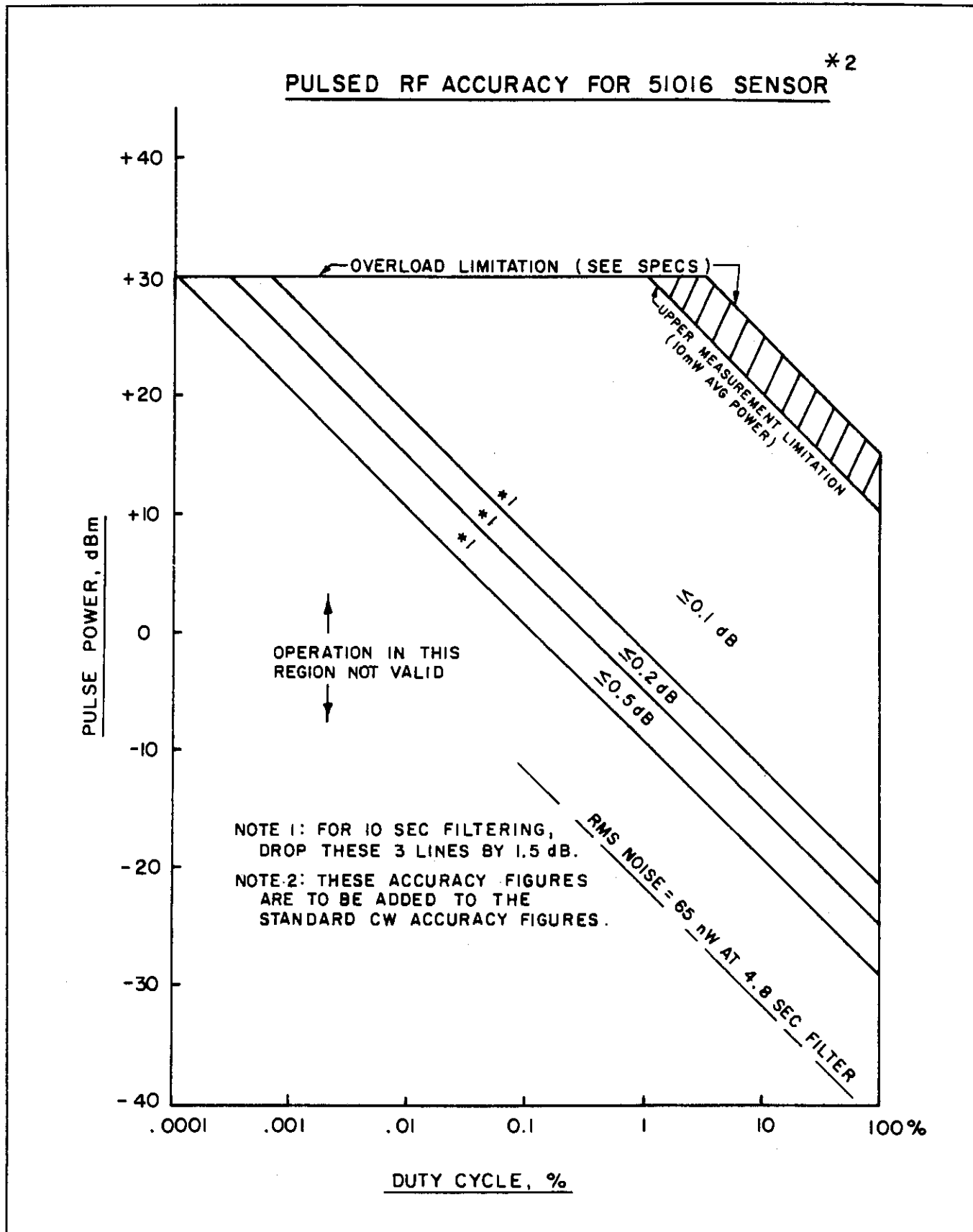

Figure 4-15. Pulsed RF Accuracy for 51016 Sensor

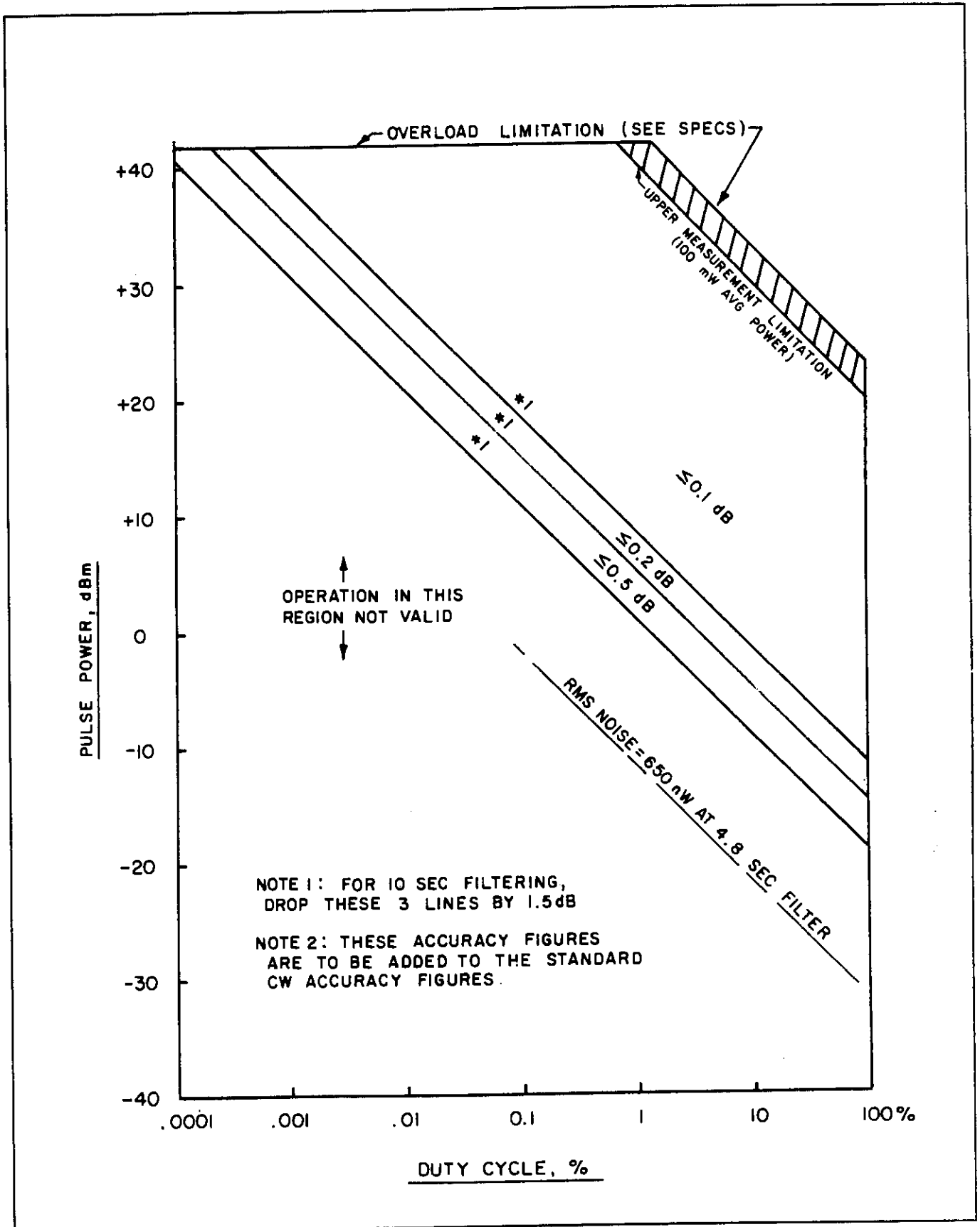

Figure 4-16. Pulsed RF Accuracy for 51017 Sensor

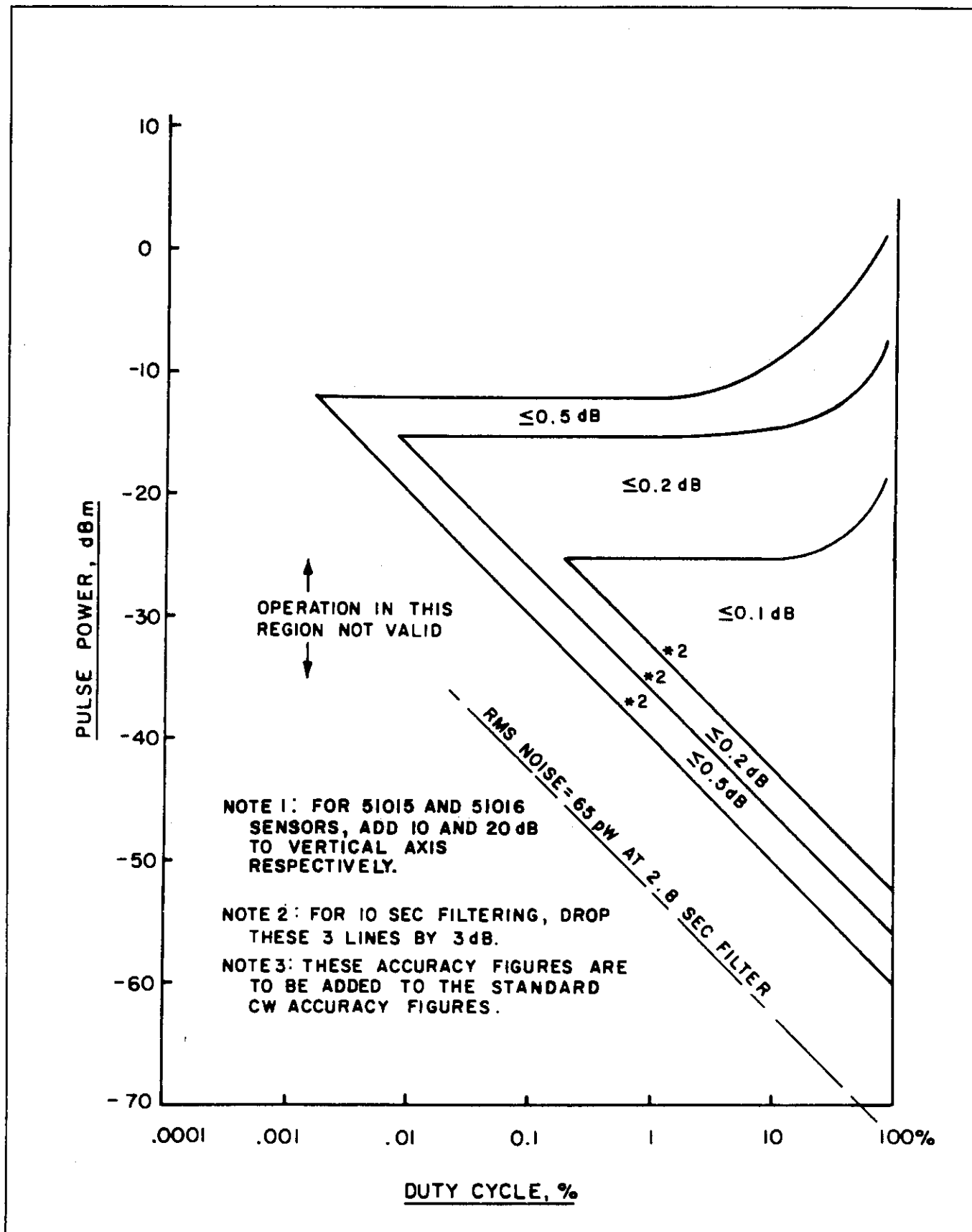

Figure 4-17. Pulsed RF Accuracy for 51013 Diode Sensor



dB modes, the output can be scaled to span any two endpoints. For example, 0 and 10 V can be set up to correspond to -20 and -15 dBm respectively. In Watts mode, the output is 0 V at zero power and 10 V at a selectable power, entered in dBm. The output impedance is 9.09K, which gives the user the option to loading it with 1K, thereby reducing the full scale output to 1 V. 12-bit output resolution is still maintained with this method. With a 1 M load the circuit is essentially open and the error is small. The displayed power is used as the input to the chart recorder DAC; therefore, all calibration and references appear at the output. The accuracy of the chart recorder is within 1% of the power measurement when operated into an open circuit.

Table 4-3 shows a summary of the chart recorder parameter selectors, which are accessed by pressing SPECIAL 2, ENTER. Then the 4300 prompts the user for the parameter selector, after which ENTER is pressed. The recorder operations are described in more detail below.

Operations on the chart recorder scaling affect all displayed channels, whether in single or multichannel mode. All channels are independent. If the scaling on one channel is set, then the 4300 can put in multichannel and the scaling for that channel will remain the same.

When an instrument initialization is done (RECALL 0), the chart recorder scaling is returned to a default condition. See the "RECALL" key description.

**1. dBm/dBr Mode Setup.** The top and bottom endpoints representing 10 and 0 V are entered with the following procedure:

- a. First select the channel desired (single channel mode) or multichannel, then press the following keys:  
 SPECIAL, 2, ENTER  
 0, ENTER  
 [Desired bottom point in dBm]  
 ENTER  
 SPECIAL, 2, ENTER  
 1, ENTER  
 [Desired top point in dBm]  
 ENTER
- b. If the last parameter selector used was either 3, 4, 5, or 6, the additional step has to be performed (this reinstates the measurement mode):  
 SPECIAL, 2, ENTER  
 7 ENTER

**2. WATTS Mode Setup.** The top endpoint is entered in dBm (the 4300 can be in watts mode but the entry is always interpreted in dBm). The bottom end power corresponding to 0 V is always zero watts. The procedure is as follows:

- a. First select the channel desired (single channel mode) or multichannel, then press the following keys:  
 SPECIAL, 2, ENTER

1, ENTER  
 [Desired top end point in dBm]  
 ENTER

- b. If the last parameter selector used was either 3, 4, 5, or 6, the additional step has to be performed (this reinstates the measurement mode):

SPECIAL, 2, ENTER  
 7 ENTER

**3. Summation Setup.** In summation mode, any one of the 6 recorder outputs can be assigned to represent the sum/difference of up to 6 channels in dB. This is useful for subtracting out the generator level (normalizing the plot). The channel whose chart recorder outputs the result does not need to be any of the channels that is used in the summation. For example, the channel 6 chart recorder can be used to show the difference between channels 1 and 2. The summed chart recorder function works in dBm mode only.

The example below shows how to set up a gain measurement, channel 1 minus channel 2, to span 15 to 25 dB (0 V is a gain of 15 dB and 10 V is a gain of 25 dB). The output is to be assigned to channel 4. Note: the scaling on channels 1 and 2 are not significant for this example. The scaling is that of the channel that is assigned to the sum. However, they can be set up normally as shown in previous sections (see dBm mode) and they will function independently.

- a. First enter the summation equation "1-2" with the summation key. Then press the following keys:  
 SHIFT  
 SET CH, 4, ENTER  
 SPECIAL, 2, ENTER  
 0, ENTER  
 15, ENTER (sets scaling on channel 4)  
 SPECIAL, 2, ENTER  
 1, ENTER  
 25, ENTER  
 SPECIAL, 2, ENTER  
 2, ENTER (assigns sum to channel 4)  
 4, ENTER  
 Σ ENA (enables sum mode)
- b. If the last parameter selector used was either 3, 4, 5, or 6, the additional step has to be performed (this reinstates the measurement mode).  
 SPECIAL, 2, ENTER  
 7 ENTER

Channel 1 would be connected to the output of the device under test and channel 2 would be connected to the generator tap. Note that the scaling and measurement modes are set up in single channel mode.

**4. Recorder Output OFF.** When the recorder output is not being used, disabling it will increase the processing throughout on the GPIB by 1 or 2 mSec per channel because the scaling operation is bypassed in the microprocessor. This is accomplished with the following procedure:

Section 4  
Making Measurements

- a. First select the channel desired (single channel mode) or multichannel, then press the following keys:  
SPECIAL, 2, ENTER  
3, ENTER
- b. Turning the recorder back on is accomplished by going back to measurement mode (see below).

5. **Zero Indicator.** The chart recorder can be used to indicate when the channel is being zeroed for purposes of turning off the signal source. The recorder output will go to a logic 0 when the zero key is pressed. The zeroing operation does not begin until 2 seconds after the key is pressed to allow the generator and sensor time to decay. Setting up this mode is done as follows:

- a. First select the channel desired (single channel mode) or multichannel, then press the following keys:  
SPECIAL, 2, ENTER  
4, ENTER
- b. To disable this mode, go back to measurement mode (see below).

6. **Limit Indicator.** The channel output can be used as a go/no-go limit indicator (the high and low limits are set by the front panel) with the following procedure. It is assumed that the high and low limit values have been set up on the channel before going into the chart recorder mode:

- a. First select the channel desired (single channel mode) or multichannel, then press the following keys:  
SPECIAL, 2, ENTER  
5, ENTER
- b. To disable this mode, go back to measurement mode (see below).

7. **Raw Value.** The recorder output can be put in a mode where its output represents the raw unprocessed A/D value (unshaped and uncalibrated) as follows:

- a. First select the channel desired (single channel mode) or multichannel, then press the following keys:  
SPECIAL, 2, ENTER  
6, ENTER
- b. To disable this mode, go back to measurement mode (see below).

**NOTE**

When the 4300 display is set for raw value mode, the chart recorder automatically represents the raw value. This mode is provided for the case when the display is showing watts or dBm, and the chart recorder still must represent the raw value.

8. **Measurement Mode.** When parameter selectors 3, 4, 5, or 6 have been executed and it is desired to disable these

and return to measurement mode, the following procedure should be performed:

- a. First select the channel desired (single channel mode) or multichannel, then press the following keys:  
SPECIAL, 2, ENTER  
7, ENTER

**4-9. TRIGGERED OPERATION AND SETTLED READING**

The 4300 has five modes of "triggering". Three of these, the free run modes, are internally triggered and are not "triggered" per se, but are included here for completeness. The five modes are accessed by pressing SPECIAL, 1, ENTER, and the number 0 to 4 as shown below. Each channel can be in a different trigger mode. This can be useful, for example, when "triggered settled" readings are required on channels 1 and 2, but channels 3 and 4 must not hold up the 1 and 2 channel readings because of an unsettled condition. (In multichannel mode, in order to get a 6 channel reading, all channels that are set to the settled reading mode must be settled.) In all of the filtered and settled modes, an SRQ is available when the reading is "filtered/settled". See the GPIB paragraph for more details. The modes are:

1. **Mode 0, Free Run.** The free run modes are internally triggered; the channels run continuously and asynchronously, taking samples every 20 mS. The display and bus are updated continuously in both single and multichannel modes. Sensor readings are put into the digital pipeline filter and "taken out" at the other end. Thus complete settling of the bus/display is delayed from step power inputs by an amount roughly equal to the digital filter length in milliseconds plus 200 mS (a typical sensor delay). However, the pipeline outputs are still available while the digital filter is ramping up/down due to the power step. If the power step is large enough to cause a range change, the digital filter contents are dumped, but data is still available at reduced accuracy (partially filtered according to how many samples have been taken). The filter "homes in" on the reading as samples accumulate in this mode. See the discussion on filtering and also measurement times in this section for more information.

2. **Mode 1, Free Run Filtered.** This mode is also internally triggered at a 20 mS rate. In the case of a range change, the digital filter contents are dumped and responses on the bus and display are held off until the digital filter is full. In this way, readings are guaranteed to be filtered. A multichannel reading will not be returned on the bus until all channels that are in this mode are filtered. The display is blanked during period of filling up, but this is done on a channel by channel basis. In multichannel mode, each channel will generally fill its filter at a different time, since the default

filter values are range dependent. If the filter length is set by the operator, however, this length applies to all ranges. All channels would normally be set to the same length in this mode (set the filter length in Multichannel mode), because then the readings will all be available at the same time.

3. **Mode 2, Free Run Settled.** This mode is also internally triggered. Responses on the bus and display are held off until the measurements are settled (settled is based on measurements and is determined by an algorithm described below). In this way, readings are guaranteed to be settled, freeing the host computer of this job. A multichannel reading will not be returned on the bus until all channels that are in this mode are settled. The display is blanked during settling, but this is done on a channel by channel basis. In multichannel mode, each channel will alternate between settled and unsettled independently (on the display) as their powers change. The channel is declared settled when the slew rate is less than about .04 dB per second. This corresponds to settling to 99%. By definition, the digital filter must be full to declare a channel settled. At low power levels, the sensor noise is usually greater than .04 dB per second. In order to provide settled capability at these levels, the acceptable settled window is opened up automatically. The settled modes operate by comparing the last half of the digital filter to the first half (old readings to the most recent); therefore a power step in the free run settled mode will not be reflected as an unsettled reading until a significant number of the new measurements are loaded into the filter. The triggered settled mode reacts immediately in this case.

4. **Mode 3, Triggered Filtered.** In this mode, all the displayed channels are triggered over the bus, or from the front panel using SPECIAL, 9, ENTER. In multichannel mode, if it is desired to trigger just one channel, the instrument can be put in single channel mode temporarily, then the trigger can be sent. Going back to multichannel mode can be done before the channel filter has filled up. Before a trigger is received, no measurements are taken and the channel does not range. When a trigger is received, the channel(s) first wait for the trigger delay time (defaults to 130 mS, but can be set, see delayed trigger below). During this time the channel ranges every 8 mS as required. Then, when the trigger delay expires, the digital filter is cleared and the readings begin, filling up the digital filter (which can be set to 20 mS if desired). Responses on the bus and display are held off until the filter is full. In this way, readings are guaranteed to be filtered. A multichannel reading will not be returned on the bus until all channels that are in this mode are filtered. The display is blanked while the filter is filling up, but this is done on a channel by channel basis. In multichannel mode, each channel will generally fill its filter at a different time, since the default filters are range dependent. See the comments for Mode 1 regarding this.

5. **Mode 4, Triggered Settled.** In this mode, all the displayed channels are triggered over the bus, or from the front panel using SPECIAL, 9, ENTER. In multichannel mode, if it is desired to trigger just one channel, the instrument can be put in single channel mode temporarily, then the trigger can be sent. Going back to multichannel mode can be done before the channel digital filter has filled up. Before a trigger is received, no measurements are taken and the channel does not range. When a trigger is received the channel(s) first wait for the trigger delay time (defaulted to 130 mS, but can be set, see delayed trigger below). During this time the channel ranges every 8 mS as required. Then, when the trigger delay expires, the digital filter is cleared and the readings begin, filling up the digital filter (which can be set to 20 mS if desired). Responses on the bus and display are held off until the filter is full. See free run settled mode for definition of settled. In this way, readings are guaranteed to be settled. A multichannel reading will not be returned on the bus until all channels that are in this mode are settled. The display is blanked during the filter settling period, but this is done on a channel by channel basis. In multichannel mode, each channel will settle at different times, because of different power levels.

6. **Mode 5, Trigger Delay.** This is not a trigger mode per se, but a parameter that is set on a channel by channel basis. (Entry of the delay can be in multichannel if it is desired to have the same delay on all channels). The trigger delay is set in 10 mS increments from 0 mS to 5000 mS. The default time is 130 mS and is set with RECALL 0 or a general instrument reset from the rear panel switch. When triggered, a channel will begin ranging and taking measurements immediately but will discard them until the trigger delay is exhausted. Then it will begin loading them into the digital filter. In this way, the channel(s) will get to the correct range even if the power step has been large, but the slowing of the sensor/source will not be integrated into the reading. This also provides a means to trigger the source and the 4300 at the same time, when it is known what the generator delay is. The default time of 130 mS is enough time for a 6 dB power step to be read correctly to 99% of settling for the diode sensors. For large power steps, refer to the section on measurement times for typical total measurement time.

#### 4-10. WAVEFORM SENSITIVITY.

The thermal sensors are insensitive to the shape of the RF waveform since they average RF power over many tens of milliseconds. Modulation, non-sinusoidal waveforms, and even pulses can be detected without distortion of the measurement. They are referred to as true RMS responding. Diode sensors are also true RMS responding below about -20 dBm (-10 and 0 dBm for the attenuated versions 51015 and 51033). This is because: 1) the sensors are dual diode types, and 2) diodes themselves respond in a square law fashion at low and medium levels. This is not an approximation but rather an inherent effect. This is because

Section 4  
Making Measurements

the diodes do not turn on and off as switches, but rather behave as signal dependent resistors. Even with no signal input, the diodes have a finite conductance, and the conductance gets modulated on a cycle by cycle basis to give a net DC offset proportional to the power.

The square law response can be seen in Figure 4-18, where a 100% AM modulated signal is shown to have virtually no effect on the measured power, at low levels. Of course, FM and PM can be measured, at any level, since the envelope of these modulated signals is flat, like CW. Frequency shift keyed (FSK) and quadrature modulation also have flat envelopes and can be measured at any power level.

At higher power levels (above -10 dBm approximately for the 51013 sensor), the diodes operate as peak detectors. The 4300 is software calibrated to calculate the RF power based on a shaping transfer function (RF to DC) for each sensor

type. However, only CW signals are valid in this region, and also in the "transition" region from -20 to -10 dBm ("CW" here refers to flat envelope waveforms such as FM, PM, etc.). Rather than discard this region as unusable, the 4300 offers it as a CW only mode when using diode sensors.

Pulsed RF waveforms can also be measured also, with either thermal or diode sensors. The 4300 will calculate the pulse power based on the duty cycle; see pulsed operation in this section.

Pulsed DC can be measured, even with DC offsets, with thermal sensors and to a limited extent with the diode sensors (the limitation is to stay in the square-law region). The repetition rate for pulsed DC should be higher than about 300 Hz for the diode sensors, otherwise the sensor begins to respond to each dip and peak. The 51051 sensor is somewhat faster and requires a minimum repetition rate of 10 KHz.

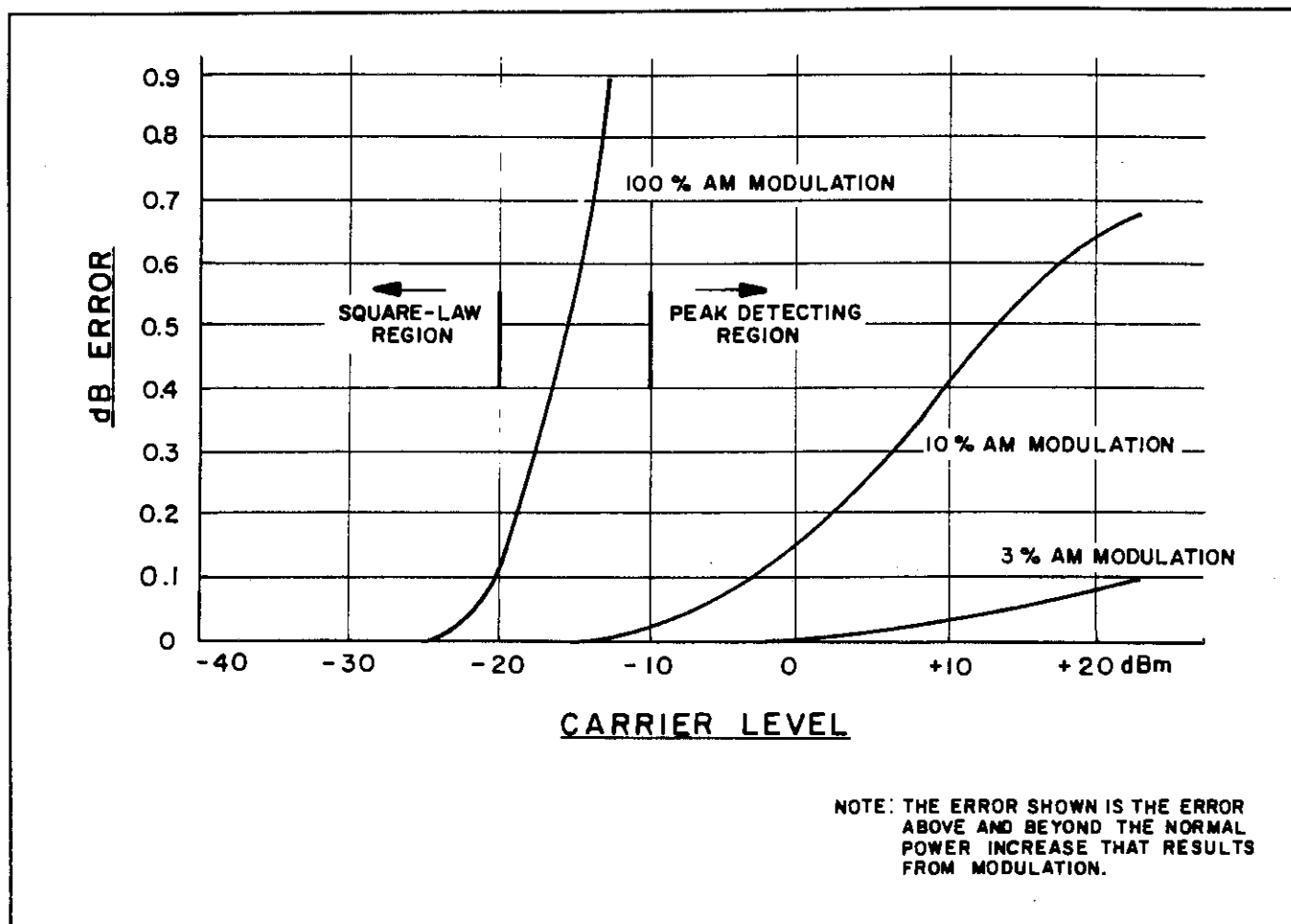

Figure 4-18. Error Due to AM Modulation  
(Diode Sensor 51013)

## SECTION 5 THEORY

### 5-1. INTRODUCTION.

This section contains information on the theory of operation of the 4300, including circuit descriptions. Refer to the Overall Block Diagram, Figure 5-1.

The input channels are modular and field installable. The sensor input to each channels is a differential DC voltage from about 1 microvolt to about 3 volts. The input channels amplify and digitize this signal, perform the digital filtering function, and triggering. The signal data, referred to as the raw value, is presented to the control board asynchronously

via the bus board at 20 mS intervals. The control board performs shaping and calibration on each channel's data, and handles all processing functions such as high frequency correction, sensor data manipulation, and autocalibration. The control board also performs the bus operations, writes to the display, and reads the keyboard.

The 30 MHz calibrator, if installed, is controlled by the control board via the 30 MHz digital board. This digital board has an EPROM which stores the calibration data for the calibrator.

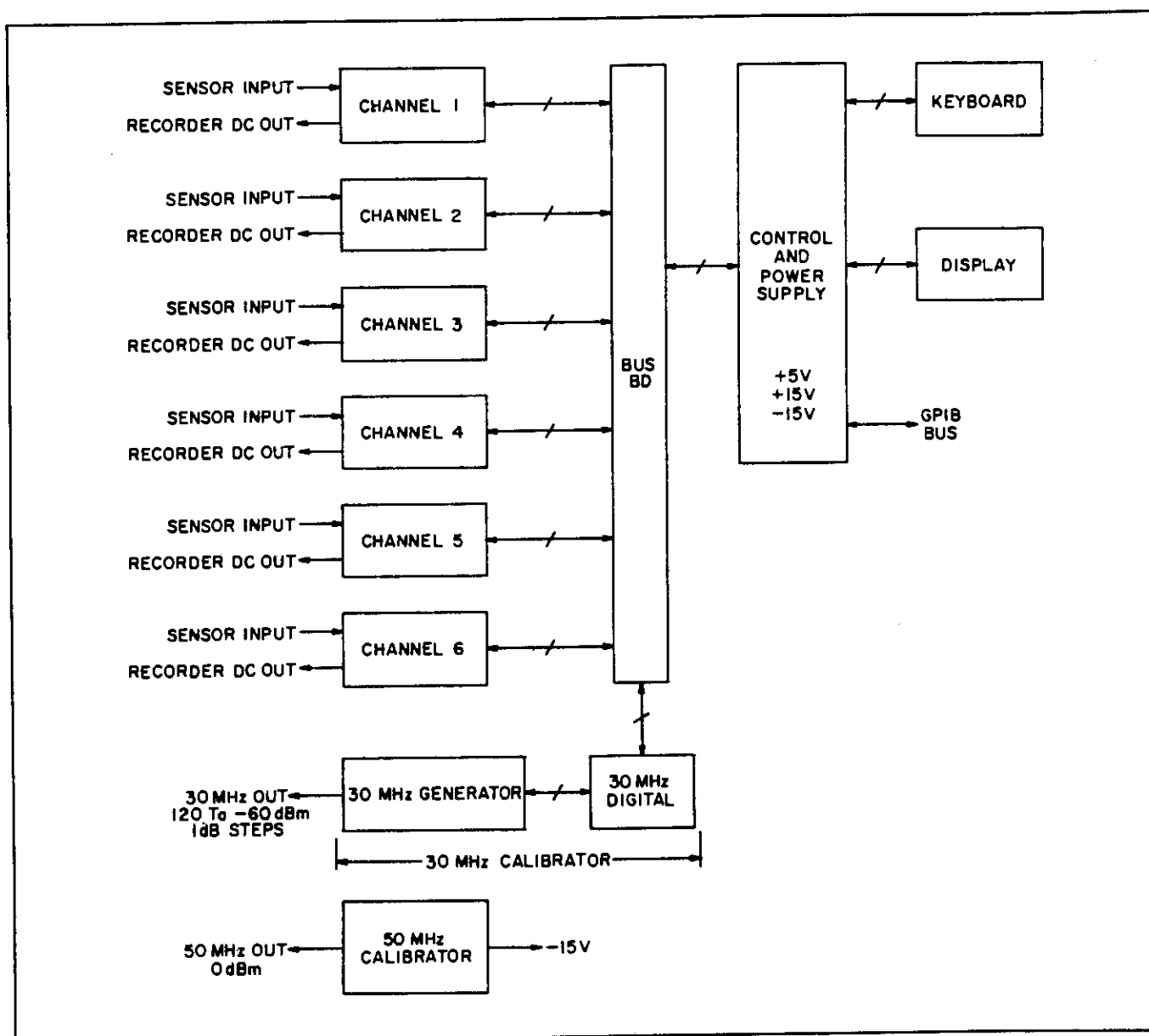

Figure 5-1. Overall Block Diagram

The 50 MHz calibrator, if installed, is fixed at 0 dBm and has no output control. Either calibrator may be installed with their outputs at the front or rear of the instrument.

The sections below describe each of the blocks in more detail.

### 5-2. SENSORS.

1. **Diode Sensors.** Diode sensors consist of a pair of noninductive 100 ohm resistors wired in parallel resulting in a precision 50 ohm load impedance. The RF voltage developed across the load resistor is coupled to the diodes by a DC blocking capacitor. The RF voltage is rectified by the diodes to produce a differential DC voltage. At powers below approximately -20 dBm (for sensors without attenuators such as 51013), the DC voltage is linearly proportional to power. Operation is in the square law region of the diode. The linearity is preserved over many decades of power. Above approximately -10 dBm, the DC voltage is proportional to RF voltage, or to power squared. To linearize the sensor response above -10 dBm, the microprocessor calculates power based on shaping data stored in memory.

Other resistors and capacitors are used in the DC path to optimize the sensor's characteristics.

2. **Thermal Sensors.** Thermal sensors use a thin film bimetallic resistor both as an RF load and also as a thermocouple. Sensitivities are on the order of 500 microvolts per milliwatt of RF power. Their output impedance is low, so bipolar op amps can be used on thermal input modules for reduced noise.

### 5-3. INPUT CHANNELS.

1. **General.** Refer to Figure 5-2. The RF power to be measured is applied to a sensor which converts RF power to a proportional DC voltage. The magnitude of the sensor's DC voltage output can vary from microvolts to volts, as a function of the power level to the sensor. Since the analog-to-digital conversion process has a relatively small dynamic range of 10:1, a variable gain instrumentation amplifier is used to scale the voltage applied to converter. To reduce the undesirable effects of the amplification process (i.e., drift, DC offset, and 1/f noise), the DC voltage from the sensor first converted to an AC square wave by the chopper. The DC voltage from the sensor first converted to an AC square wave by the chopper.

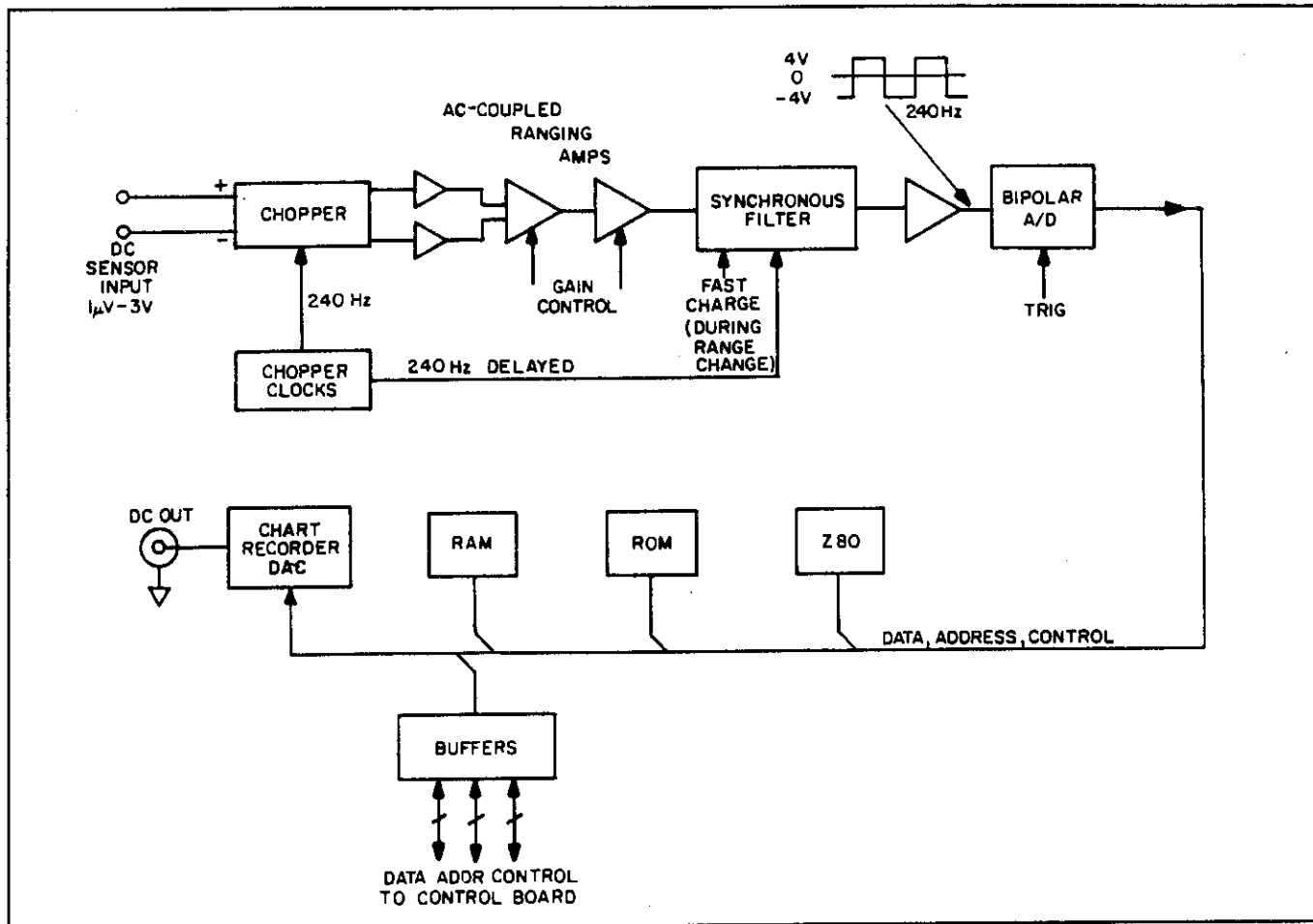

Figure 5-2. Input Board Block Diagram

2. **Chopper Circuits.** The chopper contains an integrated circuit, U1, which contains four solid-state switches. These four switches convert the differential DC voltage of the sensor to a balanced AC square wave signal by alternately reversing polarity of the two differential inputs. The switches are sequenced by chopper drive signals generated by a frequency divider chain. Potentiometers R1 and R2 provide means for cancelling capacitively coupled chopper drive transients thereby adjusting the chopper output for an overall DC offset of less than 1 microvolt. The chopping cycle is synchronized to AC power line frequency. Any interfering signal in synchronization with the power line will occur in synchronization with the chopper. In this way, errors originating from the power line can be corrected when the instrument is zeroed. The chopper circuitry is driven by a symmetrical square wave from the chopper drive circuitry.

3. **Amplifier Circuits.** The balanced AC square wave signal from the chopper is amplified by the precision instrumentation-type input amplifier. The gain of operational amplifiers AR1 and AR2 is controlled by the microprocessor through range latch U17, multiplexer switch U10, and associated feedback resistors. The AC output from AR1 and AR2 is applied to the differential inputs of AR6a which converts the signal from balanced to single-ended. This signal is next amplified by AR6b, multiplexer U14 and associated feedback resistors. The gain of this amplifier is also controlled by the microprocessor through range latch U17. The gains for the two amplifiers, the DC calibration values, and the resulting A/D count are tabulated in Table 5-1. The DC calibration is based on the Boonton 2500 or 2510 calibrators.

TABLE 5-1. INPUT CHANNEL GAIN VALUES

| DC Calibration<br>Input 90%<br>Range of Full-Scale | Amp.<br>1<br>Gain | Amp.<br>2<br>Gain | Nominal<br>A/D<br>Input |            |
|----------------------------------------------------|-------------------|-------------------|-------------------------|------------|
| 0                                                  | 9 $\mu$ v         | 502               | 165                     | 0.5 V peak |
| 1                                                  | 90 $\mu$ v        | 502               | 66                      | 2.0        |
| 2                                                  | 900 $\mu$ v       | 100               | 66                      | 4.0        |
| 3                                                  | 9 mV              | 10                | 66                      | 4.0        |
| 4                                                  | 90 mV             | 1                 | 66                      | 4.0        |
| 5                                                  | 900 mV            | 1                 | 6.6                     | 4.0        |
| 6                                                  | 4.5V              | 1                 | 1                       | 3.0        |

4. **Filter and A/D Circuits.** The synchronous bandpass filter consists of R31, C16, C17, U13, and AR3. The filter is used to condition the AC square wave signal prior to the A/D conversion. The filter is a simple resistor capacitor network which alternately switches between R31-C16 and R31-C17. The multiplexer switches U13a and U13b are driven synchronously with the chopper drive signal, thereby

directing the positive half cycle and the negative half cycle of the amplified squarewave to their respective capacitors. The RC time constant is several chop cycles long. Operational amplifier AR3 provides high impedance buffering between the filter and the A/D. Switch U13c reduces the time constant of the filter momentarily when changing ranges to allow faster charging. This switch is also closed momentarily when the instrument is triggered.

The A/D, U20 is synchronized to the chopper AC square wave and takes a sample about half way through each half chopper cycle. The A/D measures the magnitude of the AC square wave at the output of AR3 with respect to ground on both half cycles of the waveform and passes the resulting binary value to the microprocessor. A signal of approximately  $\pm 4.5$  V (9 V p-p) will cause the channel to increment range to the next higher value. On alternate chopper cycles, a voltage approximating 1/2 LSB of the A/D is added into the signal via R44. When two or more measurements are averaged in software, an effective A/D resolution of 13 bits is achieved. (A measurement consists of two A/D conversions, one conversion performed during each half of the chopper period.) Integrated circuit U19 is a precision 5 volt voltage reference for the A/D. CR4 and CR5 provide input protection for U20.

Integrated circuit U21 is a 12-bit D/A converter. Along with AR5, it provides a 0 to 10 volt DC signal to the recorder output. The control board microprocessor calculates the recorder output voltage from parameters set by the instrument user. The voltage can be proportional to power, dBm or other parameters. A 12-bit digital word representing the output voltage is sent from the control board to U21 on the channel board. The recorder is designed to drive up to 1 mA DC into a 1K ohm impedance recording device, or alternatively, a 0 volt to 10 volt DC signal into a high impedance. AR4 provides a -10 volt reference for the D/A.

5. **Digital Circuits.** The Input Channel Module is controlled by an 8 bit microprocessor which performs the following functions:

- a. A/D synchronization.
- b. Zero determination.
- c. Zero correction.
- d. Ranging.
- e. Channel calibration.
- f. Processing of measurement data (digital filtering).
- g. Transmission of measurement data to and from the control board.
- h. Recorder output.
- i. Instrument trigger synchronization.

Each Input Channel uses a Z-80 microprocessor U2, with random-access-memory (RAM) U3, and read-only-memory

## Section 5

### Theory

(ROM) U1. Program instructions that control the activity of the board are stored in the ROM. The RAM is used to store both temporary and permanent data. Calibration constants for gain, range, digital filter selection, measurement values, and zero correction data are stored in the RAM. BT1 is a 3 volt lithium battery which provides backup power to the RAM making it a nonvolatile memory. A bit switch, S1, is provided to configure the processor for alternate uses. Integrated circuit U4 is a data buffer between the microprocessor and switch and the chopper drive. The microprocessor monitors the chopper drive to maintain synchronization of the A/D with the chopper drive. The control board accesses the input channel RAM through the line buffers U7, U8, and U9 and the card edge connector. All communications between the control and channel boards is via memory locations in the channel RAM. When the channel RAM is accessed by the control board, the channel's Z-80 is halted for 100 microseconds or less.

#### 5-4. CONTROL BOARD.

1. **General.** Refer to Figure 5-3. The operation of the instrument is under control of a 16-bit microprocessor.

Associated hardware includes the RAM, ROM, I/O devices, and a number of glue logic gates. Control board functions are as follows:

- a. Signal processing (shaping).
- b. Calibration.
- c. Power to dB conversion.
- d. Recorder output processing.
- e. Diagnostics.
- f. Keyboard and display control.
- g. GPIB control.

2. **Microprocessor Circuits.** The microprocessor U19, is a 68008 which operates at a clock frequency of 8 MHz. The software resides in ROM U6, U10, and U18. ROM U6 stores the control program. U18 stores the tables of functions pertinent to the many sensors available for use with the instrument. ROM U10 contains software and tables for implementation of MATE on the GPIB.

3 volt lithium battery BT1, provides backup power to the RAM. A memory protection circuit, U17a, c, and d, eliminates the possibility of erroneous data being written to the RAM during uncertain circuit conditions that occur at power-up or power-down.

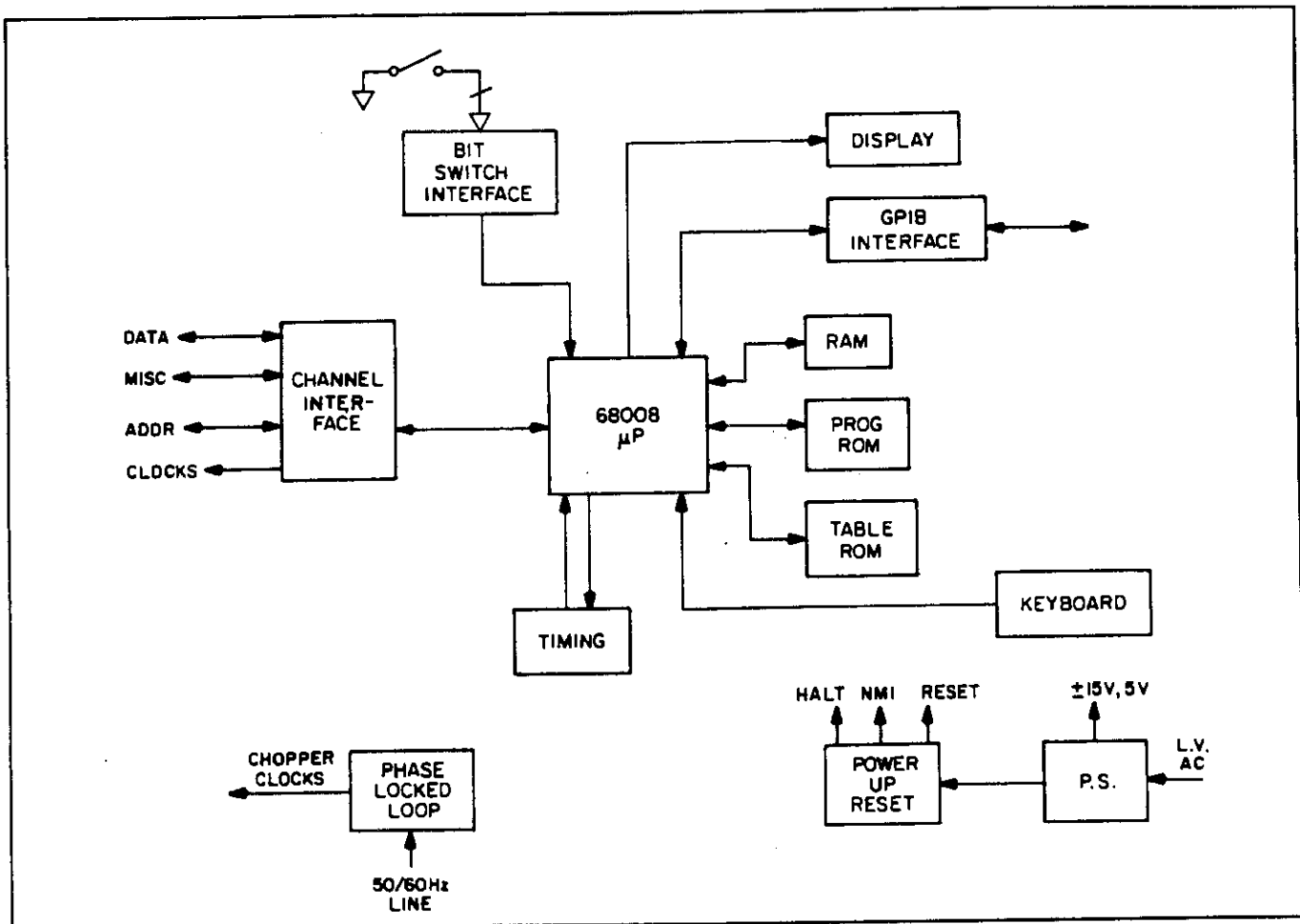

Figure 5-3. Control Board Block Diagram



Each circuit associated with the microprocessor has a unique timing requirement. The RAMs and ROMs; for example, are much faster than I/O circuits such as the channel or calibrator assembly. The microprocessor has the capability to change the speed of data exchange to match the parameters of both memory and I/O. The system clock frequency of 8 MHz is divided by U11, a divide by 16 counter to give both a 2 MHz and 4 MHz clock frequency. Gates U13a, b, c output logic signals which cause latch U8a, b to capture the period of either the 2 or 4 MHz clock. The period is sensed by the microprocessor DTACK input and is used as timing for I/O and memory. Signals FC0, FC1 and FC2 from the microprocessor are combined in U14a, b, and U16e to initiate the auto vector interrupt mode of the microprocessor. Integrated circuits U1, U2, U3, and U4 provide buffering between the microprocessor and channel cards.

3. **Display Circuits.** The liquid-crystal-display (LCD) is controlled by integrated circuit U24 which buffers data flow between the microprocessor and display. OR gate U15d ensures correct timing of the data transfers. Voltage regulator U29 provides -5V to adjustable potentiometer R27, which adjusts the LCD viewing angle and contrast.

4. **Keyboard Circuits.** The keyboard is controlled by IC U34 and provides the following functions; automatic scanning of the keyboard for key switch closure, First-In-First-Out RAM storage for up to 8 keystrokes of input commands, and keystroke debouncing. Keyboard data is passed to the microprocessor on the data bus.

5. **GPIB Circuits.** The GPIB General-Purpose-Interface-Bus is controlled by IC U32 which is a microprocessor drive data interface which converts IEEE-488 bus compatible signals into control codes that operate the internal functions of the instrument. It also converts instrument data into IEEE-488 compatible signals for transmission on the bus. Integrated circuits U25 and U26 are buffers between the GPIB controller and the bus.

6. **Power -On Reset Circuits.** All of the microprocessors in the instrument require signals to properly initialize and end their operation when the instrument power line is switched. An IC comparator, U22a, b, c, is used to monitor the status of the line via voltages present in the power supply and generate NMI, HALT, and RESET in the correct sequence. Refer to the timing diagram on the schematic. Time delays in the sequence are determined by R12-C13 and R18-C14. IC U23a, b, c, and e are buffers. Operation is such that a momentary power outage will reset the instrument.

R9 is set so that when the unregulated 5V (8-12V) drops below 8V, an NMI is generated (8 V is the minimum level

that will guarantee 5 V at the output of the regulator U1). The NMI stops the 68008. The halt and reset lines then go active in sequence. Since U23 is an open collector gate, the rise time is much longer than the fall time, assuring that on power up, the power supply has had time to move away from the 8 V threshold.

7. **Chopper/Line Synchronization Circuits.** The channel and the chopper assemblies receive drive signals which are synchronized to the power line frequency. Synchronization to the line aids in the rejection of line produced noise from the sensitive input circuitry and the input cables, because the noise is repeatable from cycle to cycle and can therefore be zeroed out. Synchronization is accomplished by sampling of the AC voltage at the secondary of the power transformer by U37, CR8, and CR9. A Phase Lock-Loop consisting of U35 and U36 generate square wave signals at 480 Hz and 1920 Hz (with a 60 Hz line) in phase with the line.

The instrument's power line frequency response is specified over a range from 50 Hz to 400 Hz. At line frequencies other than 50/60 Hz, another method of deriving chopper drive is needed. Binary divider U21 is the contingency method of generating the chopper drive signals. A 1 MHz signal is frequency divided to produce 488 Hz and 1953 Hz.

#### 5-5. 30 MHz CALIBRATOR.

1. **General.** Refer to Figure 5-4. The calibrator is a microprocessor-controlled, software-calibrated 30 MHz crystal controlled generator. The described power output may be programmed from the keyboard or IEEE-488 bus in 1 dB steps from +20 dBm to -60 dBm. The output impedance is 50Ω at 30 MHz.

2. **Oscillator Circuits.** Transistor Q1, crystal Y1, and the associated components form an oscillator. The oscillator is buffered by emitter follower Q4. During normal operation, the base of Q2 is held low by the 82C55, however, when the zero button is depressed on the front panel, transistor Q2 is turned off, cutting the Vcc supply to the oscillator and the buffer.

3. **Power Amplifier circuits.** Transistor Q5 is configured for class C operation. The power output is a function of Vcc supply through Q3 which is controlled by the leveling loop. This signal is applied to a low-pass filter by the tuned circuit C12 and L6.

4. **Low-Pass Filter Circuits.** The low-pass filter consists of L7, L8, C14, C17, C16, and C18. The harmonic content is reduced to less than -65 dB by this filter.

5. **Amplitude Control and Leveling Loop Circuits.** During calibration, compensation data for each attenuator

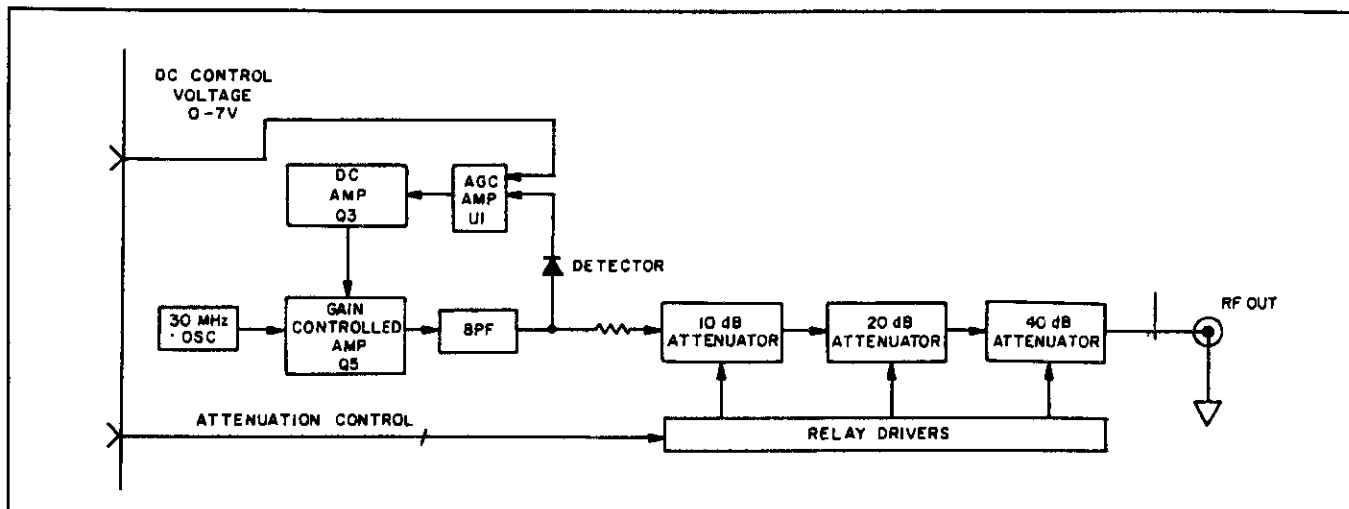

Figure 5-4. 30 MHz Generator Block Diagram

in each calibrator is stored in the calibration EEPROM U3. One constant is stored for each full-scale output (10 dB step). The DC voltage from the DAC is filtered by C3, temperature compensated by RT1 and R18 and applied as set-point for the integrated AR1. The 30 MHz signal from the low-pass filter is detected by CR3 and filtered by C15, and applied to pin 2 of AR1. The detected level is compared to the DAC voltage. The DAC provides the calibrated full-scale voltages for each 10 dB increment, and also is used to step the output in 1 dB steps. Unequal loading resistors on the AC detector diode and the DC compensation diode compensate for the slight inefficiency of the AC detector (it tends to have an output component that is a result of the diode integrating over the 30 MHz cycle). The integrator controls the Vcc supply to the power amplifier and therefore the power output. Capacitor C10 provides the necessary loop compensation.

This integral feedback loop connection makes the junction of R19, CR3, and C20 act as a voltage source which tracks the reference voltage. Therefore, the (4) 200Ω in parallel along with compensated switch contacts make the output impedance 50Ω at 30 MHz.

6. **Attenuator Circuits.** The attenuator consists of 10 dB, 20 dB, and 40 dB pads respectively. The complete amplifier/attenuator chain is programmable in 10 dB and 1 dB steps for maximum attenuation of 80 dB. Q6-Q8 are relay drivers.

7. **30 MHz Digital Board A3.** Refer to Figure 5-5. The unipolar configuration of the D/A will provide 0 to +10 volts. This voltage is used as the reference voltage for the leveling loop. The typical DC voltage for full scale (+20 dBm, +10.0, etc.) is 6.7 V and 2.38 V for downscale (-9 dB).

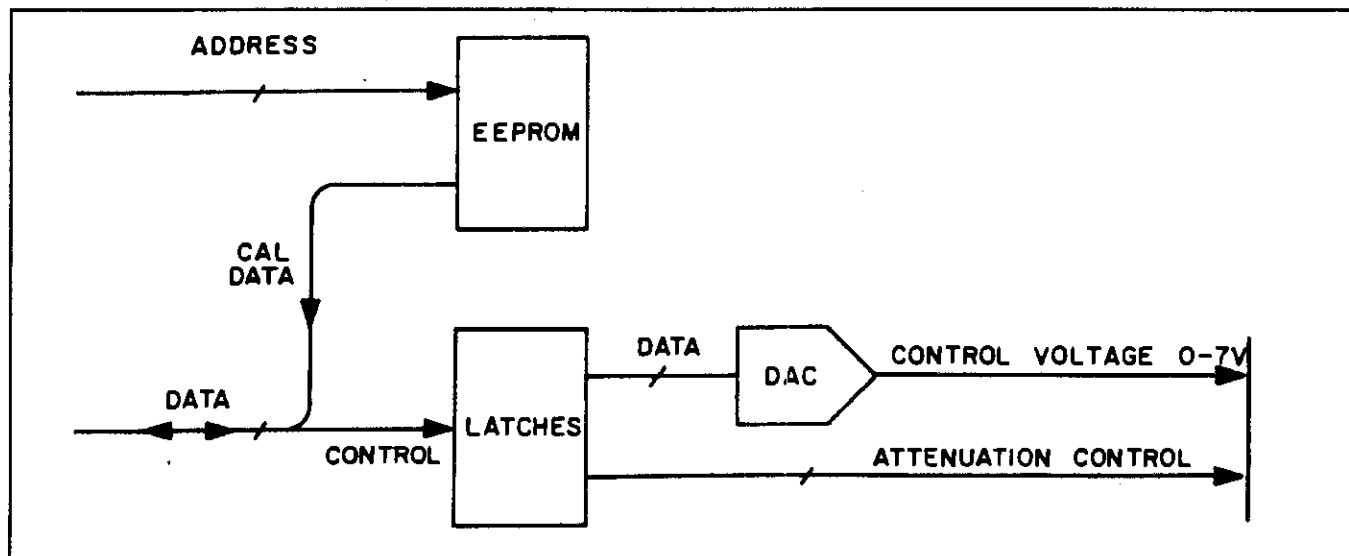

Figure 5-5. 30 MHz Digital Block Diagram

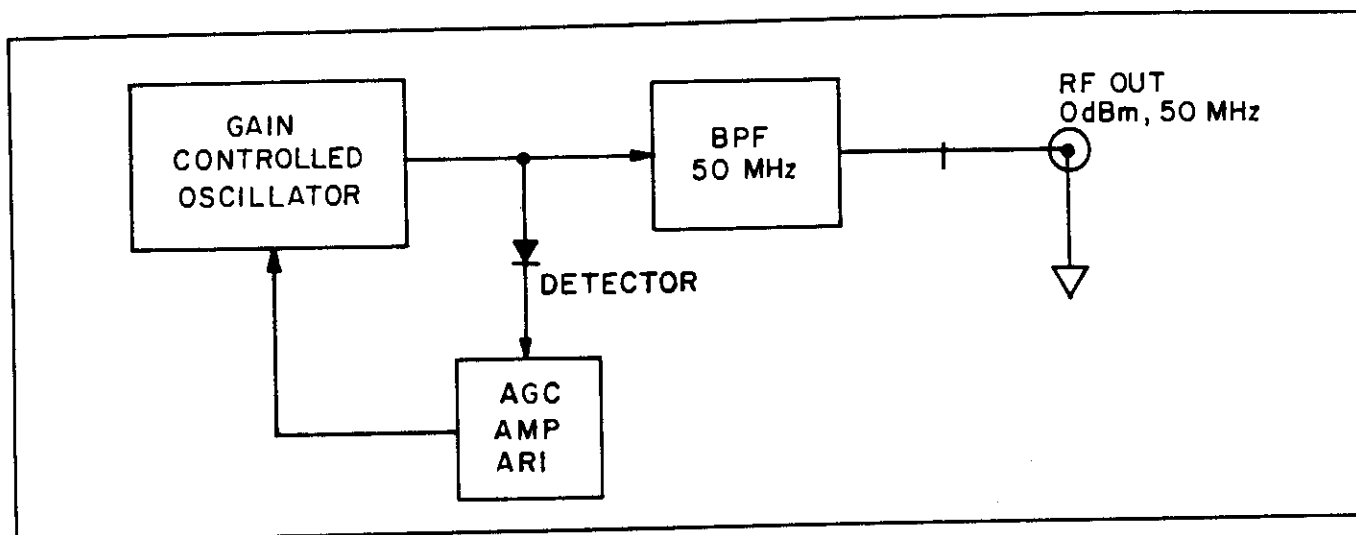

Figure 5-6. 50 MHz Calibrator Block Diagram

#### 5-6. 50 MHz CALIBRATOR.

Refer to Figure 5-6. The reference signal is generated by transistor oscillator Q1, which operates at  $50 \pm 0.5$  MHz. An automatic leveling circuit is used to maintain a constant reference power level. Leveling is achieved by rectifying the oscillator output signal in the signal level detector circuit, and comparing the resulting DC voltage with a stable DC voltage developed by voltage reference IC1. The difference voltage is amplified by operational amplifier A1, and the output level from the operational amplifier controls a varactor in a capacitive divider that determines the drive to the oscillator. A second capacitive divider at the output of the oscillator divides the oscillator output signal and tends to provide some isolation from the load. The sense point for the leveling loop is at the junction of L1 and L2, so this is a zero impedance point for AC. Therefore, a 50 ohm series resistor is used to establish the desired 50 ohm source resistance. The output reference power level signal is available at the front panel POWER REF connector.

## SECTION 6 MAINTENANCE

### 6-1. INTRODUCTION.

This section contains the safety requirements, required test equipment, cleaning procedures, removal and replacement procedures, inspection procedures, and three major subsections:

- 6-100. PERFORMANCE TESTS.
- 6-200. ADJUSTMENTS.
- 6-300. TROUBLESHOOTING.

### 6-2. SAFETY REQUIREMENTS.

Although this instrument has been designed in accordance with international safety standards, general safety precautions must be observed during all phases of operation, service and repair of the instrument. Failure to comply with the precautions listed in the Safety Summary at the front of this manual or with specific warnings given throughout this manual could result in serious injury or death. Service and adjustments should be performed only by qualified service personnel.

### 6-3. TEST EQUIPMENT REQUIRED.

Test equipment required for the performance tests, adjustments, and troubleshooting is listed in Table 6-101.

### 6-4. CLEANING PROCEDURE.

Painted surfaces can be cleaned with a commercial, spray-type window cleaner or with a mild soap and water solution.

#### CAUTION

Avoid the use of chemical cleaning agents which might damage the plastics used in the instrument. Recommended cleaning agents are isopropyl alcohol, kelite (1 part kelite, 20 parts water), or a solution of 1% mild detergent and 99% water.

### 6-5. REMOVAL AND REPLACEMENT.

1. **Instrument Covers.** Remove the instrument covers as follows:

- a. Disconnect the power cord and all signal cables from the instrument.
- b. Remove the three screws located at the rear of the cover.

- c. Slowly lift the cover up and to the rear.
- d. Remove the shield on the left side of the instrument.
- e. Turn the instrument over and remove the bottom cover in the same manner as the top cover was removed.
- f. Remove the bottom shield.
- g. To replace the covers reverse the removal procedure.

2. **Boards and Modules.** Refer to Section 2 for removal and installation of modules.

### 6-6. INSPECTION.

If an equipment malfunction occurs, perform a visual inspection of the Model 4300. Inspect for signs of damage caused by excessive shock, vibration, or overheating, such as broken wires, loose hardware and parts, loose electrical connections, electrical shorts, cold solder connections, or accumulations of dirt and other foreign matter. Correct any problems discovered, then perform the performance tests to verify that the instrument is operational. If a malfunction persists or the instrument fails any of the performance tests, refer to the adjustment procedures. After the instrument has been adjusted, perform the performance tests again to verify instrument operation. If the instrument cannot be adjusted, or fails the performance tests refer to the troubleshooting procedure.

### 6-7. BATTERY REPLACEMENT.

The Model 4300 uses lithium or alkaline coin-cells to provide standby power for the static RAM chips which maintain calibration data, operating parameters, and operating states of the instrument and input channels when the instrument is off. Lithium cells should last 5 to 10 years under most conditions, and alkaline cells (available as a special order option) about 3 to 5 years at room temperature. There is one battery on the control board, and one on each input channel board (two on each, if alkaline).

The static RAM chips will maintain data integrity down to 2.0 volts supply voltage. The batteries should be replaced any time their voltage falls to 2.4 volts or less. This should be checked at the time of calibration, which must be at least once every two years, preferably annually. If any one battery in the instrument is found to be low, all of them should be replaced at once.

### BATTERY TYPE AND VOLTAGE

Lithium: BR-2325-1HB, 3 V Boonton P/N 556007000  
Alkaline: LR44, 1.5 V Boonton P/N 55600900A

The battery replacement procedure is as follows:

1. Remove the top and bottom covers of the instrument, and remove the aluminum inner shield that covers the control board on the left side of the instrument.
2. Remove the two screws in the mother board that hold each of the input boards in place, and the #6 screw on each input board at the rear panel.
3. Pull the red and black wires on each input board out from the teflon feedthroughs behind the front panel. These wires are on spring loaded pins.
4. Remove all of the input boards.
5. Turn on power to the 4300 so that power will still be applied to the static RAM chips while the batteries are removed. This prevents loss of data.
6. Remove the battery(s) on the control board. Note the orientation as the cells are removed, and make sure to install the new cells in the same orientation. Lithium cells are soldered in place, and must be unsoldered. Use a grounded-tip soldering iron, but be careful to only touch the circuit board traces that connect to the battery. Alkaline cells are in a holder, and can be removed simply by pulling the two cells out of the holder. The top battery holder may have to be removed to gain access to the bottom cell.
7. With the power still on, install the new battery(s). The lithium cell must be soldered in place. Since the grounded soldering iron tip will short out the cell when touched to the positive (+) terminal, soldering time should be kept to a minimum - no more than two seconds if possible. Alkaline cells are installed by pressing the two new cells back into the battery holder.
8. Turn off power to the 4300. For each input channel, replace its battery using the following steps:
  - a. Remove the aluminum shield from the input board (alkaline only).
  - b. Insert the extender card into one of the input slots, and plug the input channel into the top of the extender card. Turn instrument power on.
  - c. Replace the battery(s) on the input card using the same procedure as for the control board (steps 6 and 7, above).

- d. Turn instrument power off. Unplug the input module from the extender card and install it back into one of the input slots, without the extender card.

9. Reassemble the 4300. On the input boards, the black wire goes to the white feedthrough.

10. Power up the instrument and perform a memory test (press ESCAPE, TEST, 3, ENTER). The display should indicate OK within a few seconds.

#### NOTE

An alternative to replacing the input board batteries with instrument power on is to copy the data on the input board label, replace the battery with power off, and re-enter the calibration data using SPECIAL 3. If this is done, perform a hard reset of the input board before entering the data. This is done as follows: set the channel's bit switch to all 1's, power up, wait 3 seconds, and power down. Then set the bit switch back to its original position, and cycle instrument power *twice* in the same fashion as before.

#### 6-8. 400 Hz OPERATION.

The 4300 Power Meter is factory configured to operate with a 50/60 Hz line frequency. Internal signal processing is synchronized to the AC line for maximum rejection of line frequency noise and interference. For operation at 400 Hz or other frequencies, this synchronization is not possible, and an internal clock must be used in place of the line frequency reference. The following procedure may be used by qualified service personnel to convert the Model 4300 for operation at frequencies other than 50/60 Hz:

1. With the instrument power unplugged, remove the top and bottom covers of the instrument, and remove the aluminum inner shield that covers the control board on the left side of the instrument.
2. Refer to schematic 83146113F and layout diagram 04310300H on pages 8-23 and 8-22. (Note that U21 is shown dashed on the schematic, because it is not installed in the 50/60 Hz version). Install a CD4040BE (Boonton P/N 534275000) in the empty PC board location between Y1, U20, and U8. A socket may be used if desired (Boonton P/N 47301900). Orient the IC the same way as the other IC's in the group - pin 1 to the left as indicated by the dot marking on the PC board. Carefully solder the IC or socket into place using a grounded-tip soldering iron. If a socket is used, plug the IC into the socket.
3. Cut the two jumpers on the PC board from E7 to E8 and from E10 to E11.

4. Solder two new jumpers into place, one from E6 to E7, and the other from E9 to E10.

5. Power up the unit and test it at 0 dBm or another convenient point, and reassemble the instrument.

Note that the 4300 will still operate at 50/60 Hz with this change, but measurements will not be synchronized to the AC line. This could cause a small amount of additional measurement noise at the lowest signal levels.

**TABLE 6-101. MAINTENANCE TEST EQUIPMENT**

| <b>Equipment</b>          | <b>Specification</b>                                              | <b>Suggested Model</b>                                   |
|---------------------------|-------------------------------------------------------------------|----------------------------------------------------------|
| Signal Source             | Must cover range of levels compatible with the sensor to be used. | Boonton Model 2520<br>Boonton Model 25A<br>HP 3335A      |
| Milliwatt Test Set        | $\pm 0.015$ dBm at a level of 0.00 dBm.                           | Wandel and Goltermann<br>Model EPM-1 with<br>TK-10 probe |
| Counter                   | 50 MHz                                                            | Ballantine Model 5500B                                   |
| Oscilloscope              | Bandwidth of 100 MHz.<br>Sensitivity of 5 mV/div.                 | HP Model 1740A with<br>a 10X probe                       |
| 50 $\Omega$ Termination   | 50 $\pm$ 1 ohm.                                                   | Boonton Model 91-15A                                     |
| DC Voltmeter              | .05% basic accuracy.                                              | Fluke 8840A                                              |
| 10 dB fixed Attenuator    | 50 ohm, N type conn.<br>10 dB $\pm$ 0.5 dB.                       | Weinschel Engineering<br>Model 1                         |
| 20 dB fixed Attenuator    | 50 ohm, N type conn.<br>20 dB $\pm$ 0.5 dB.                       | Weinschel Engineering<br>Model 1                         |
| 30 dB fixed Attenuator    | 50 ohm, N type conn.<br>30 $\pm$ 0.75 dB.                         | Weinschel Engineering<br>Model 1                         |
| 40 dB fixed Attenuator    | 50 ohm, N type conn.<br>40 $\pm$ 0.75 dB.                         | Weinschel Engineering<br>Model 1                         |
| Calculator                | Scientific key for the antilog function.                          | Hewlett Packard #21                                      |
| 2 dB fixed Attenuator     | 50 ohm, N type conn.                                              | Weinschel Engineering<br>Model 1                         |
| 4 dB fixed Attenuator     | 50 ohm, N type conn.                                              | Weinschel Engineering<br>Model 1                         |
| 6 dB fixed Attenuator     | 50 ohm, N type conn.                                              | Weinschel Engineering<br>Model 1                         |
| 8 dB fixed Attenuator     | 50 ohm, N type conn.                                              | Weinschel Engineering<br>Model 1                         |
| DC Range Calibrator       | Differential, adjustable source impedance.                        | Boonton Model 2510                                       |
| Coaxial Switch (optional) | N type connectors.                                                | HP 8761B                                                 |
| Sensors                   | N connectors.                                                     | Boonton Model 51013<br>and 51075                         |
| Variac                    | $\pm$ 30% of nominal line voltage.                                |                                                          |

## SECTION 6-100 PERFORMANCE TESTS

### 6-101. INTRODUCTION.

The performance tests should be performed about every 12 months or after the instrument has been repaired. The performance tests may also be performed when the Model 4300 is first received to verify instrument performance.

The Performance Tests consist of the following:

1. Power Supply Test.
2. Battery Test.
3. Display Test.
4. Key Test.
5. Memory Test
6. Bit Switch Test.
7. ROM Test.
8. Bus Test.
9. Chopper Offset Test.
10. Reference Frequency Accuracy Test.
11. DC Calibration Test.
12. Auto Calibration Test.
13. 30 MHz Calibrator Performance Tests.
14. 50 MHz Calibrator Performance Tests.
15. Chart Recorder Verification Test.

### 6-102. POWER SUPPLY TEST.

#### WARNING

There are voltages at various points in the instrument which can, if contacted, cause personal injury. Observe all safety precautions. Service and adjustment should be performed by trained service personnel only.

Perform the power supply test as follows:

1. Remove all power from the instrument.
2. Remove the top cover of the instrument and the EMI shield on the left side of the instrument.
3. Connect power to the instrument and set the LINE ON/OFF switch to ON.
4. Connect a DVM to A7TP9 and ground; the voltage should be +5 vdc  $\pm 5\%$ .
5. Connect a DVM to A7TP10 and ground; the voltage should be +15 vdc  $\pm 5\%$ .
6. Connect a DVM to A7TP12 and ground; the voltage should be -15 vdc  $\pm 5\%$ .

6-103. **BATTERY TEST.** Perform the battery test as follows:

1. Press TEST, 7, ENTER.
2. The display will indicate one of the following:
  - a. **Battery OK:** There are no failures found by this test.
  - b. **Battery Fail:** A display showing the letter "C" indicates a failure on the control board. A number in a box indicates the channel on which the failure occurred. When multiple failures occur, the display indicates all failures simultaneously.  
Example: C    1    3    4    6  
                  indicates failure on the control board, channel 1, channel 3, channel 4, and channel 6.
3. Press ESCAPE to return the instrument to the measurement mode.

6-104. **DISPLAY TEST.** Perform the display test as follows:

1. Press TEST, 2, ENTER.
2. The display will indicate the following, in sequence:
  - a. **Display Test.**
  - b. A display consisting of all characters lit forming 80 completely filled rectangles.
  - c. A display of the entire alphabet set, and special characters.
3. Press ESCAPE to return the instrument to the measurement mode.

6-105. **KEY TEST.** Perform the key test as follows:

1. Press TEST, 1, ENTER.
2. The display will indicate **Key Test**.
3. Beginning with the ENTRY key, press each key in sequence from left to right, then top to bottom. When each key is pressed, then make sure that the display indicates the scan code for that key position as shown in Table 6-202.

**TABLE 6-102. KEY TEST KEY CODES**

|                                                   |
|---------------------------------------------------|
| [**] [1] [2] [3] [4] [5] [6] [7] [26] [29]        |
| [8] [9] [10] [11] [12] [13] [14] [15] [25] [28]   |
| [16] [17] [18] [19] [20] [21] [22] [23] [24] [27] |
| ** = [ESCAPE] key                                 |



Section 6-100  
Performance Tests

4. Press ESCAPE to return the instrument to the measurement mode.

**NOTE**

The instrument will return to the measurement mode after some time period or after any sequence of keystrokes.

6-106. **MEMORY TEST.** Perform the memory test as follows:

1. Press TEST, 3, ENTER.
2. The display will indicate one of the following displays:
  - a. **Memory OK:** There are no memory errors.
  - b. **Memory Fail:** A display showing the letter "C" indicates a failure on the control board. A number in a box indicates the channel on which the failure occurred. When multiple failures occur, the display indicates all failures simultaneously.

Example: **C1346**  
indicates failure on the control board, channel 1, channel 3, channel 4, and channel 6.

3. Press ESCAPE to return the instrument to the measurement mode.

**NOTE**

The Memory Test will not detect certain memory failures. For example, random bit dropouts that occur over a period longer than that of the memory test.

6-107. **BIT SWITCH TEST.** Perform the bit switch test as follows:

1. Press TEST, 4, ENTER.
2. The display will indicate the following:  
**C sw1 B B B B B B B B**  
B's designate bits (the MSB is at the left)
3. Press any key except ESCAPE.
4. The display will sequence through the following patterns for each channel that is installed (empty channels will be skipped). Refer to the Notes below for the meaning of the displays.

- a. **C sw2 B B B B**
- b. **1 sw1 B B B B**
- c. **2 sw2 B B B B**
- d. **3 sw3 B B B B**
- e. **4 sw4 B B B B**
- f. **5 sw5 B B B B**
- g. **6 sw6 B B B B**

**NOTES**

"C sw1 " specifies the control assembly switch 1.  
" 1 sw1 " specifies " channel 1 switch 1 ".

Press ESCAPE to return the instrument to the measurement mode.

6-108. **ROM TEST.** Perform the ROM test as follows:

1. Press TEST, 6, ENTER.
2. The display will indicate the following:

**BOONTON ELECTRONICS CORPORATION**      **TABLE ROM**  
**4300 Version V.VV\***                              **Version V.VV\***  
\* V.VV = the resident software version.

3. Press any key except ESCAPE.
4. The display will sequence through the following patterns for each channel/calibrator that is installed.
  - a. **MATE ROM**                              **Version V.VV**
  - b. **CALIBRATOR**                              **Version V.VV**
  - c. **CHANNEL 1**                              **Version V.VV**
  - d. **CHANNEL 2**                              **Version V.VV etc...**
5. Press ESCAPE to return to the measurement mode.

6-109. **BUS TEST.**

1. Refer to Figure 6-101. The bus test is a debugging aid. When selected, this command will cause the instrument to enter a special submode where the display is used to show information about the IEEE-488 interface. The information on the display can be broken up into four different groups. They are the Bus test message in the upper right, Bus operating status lower right, Bus line status lower left, and the present listen buffer image of the instrument in the upper left.

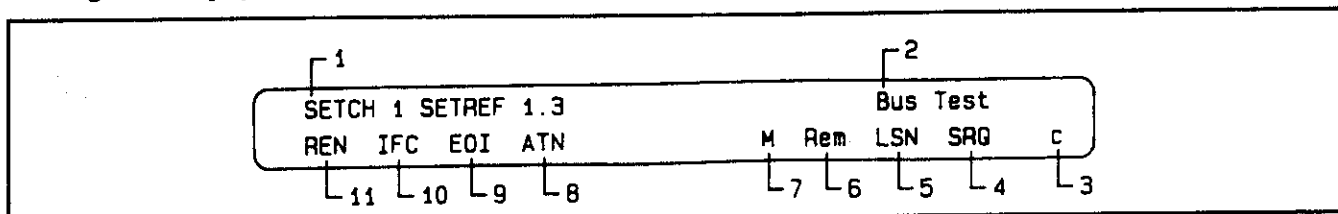

Figure 6-101. Bus Test Display

2. The Bus test message (item 2) indicates that the bus test submode is active.

3. The bus operating status (items 3 through 7) indicates the current operating status of the instrument on the bus. This display is active whenever the instrument is active on the bus. The "M" character (item 7) only appears if the instrument has the MATE option installed and the unit is operating in the MATE mode on the bus. The "Rem" (item 6) message appears when the instrument goes remote in response to a controller request. The "LSN" message (item 6) shares its location with the "TLK" message. These messages indicate if the instrument is addressed to listen or talk by the controller. This location can be shared because an instrument can not be addressed to talk and listen at the same time. The "SRQ" message (item 4) indicates that the instrument is requesting service from the controller but the controller has not yet responded. The "c" character (item 3) can appear when the instrument is in any mode of operation and indicates if the internal programmable calibrator output is enabled.

4. The bus line status section of the display shows the condition of the specific hardware lines on the bus. If the message appears, then the signal is active on the line. The "REN" message (item 11), which stand for Remote Enable, indicates that a controller is active on the bus and is requiring that the instrument go into remote mode. This message should always be present during remote operation. If not, check the cable connections and then check that the controller is active and is asserting this line. The "IFC" message (item 10), which stands for Interface clear, is a command signal for all instruments on the bus to clear their interfaces. This line should only be active for short periods of time, if not, all the instruments on the bus may appear inoperable. The "EOI" message (item 9), which stands for End or Identify, is a command signal asserted by the current talker and can be used by all listeners to identify the last character in a message. The use of this line is optional, but the 4300 is able to use it for talking and listening, and for in-line termination characters. If not functioning properly, this line can cause the instruments on the bus to have the bus waiting for proper message termination. The "ATN" message (item 8), which stands for Attention, is a signal that can only be asserted by the controller in charge. This signal is used by the controller to take control of the bus, which means all instruments must stop bus operation and obey the controller. This line is very important for correct operation of the bus and will normally be asserted at periodic intervals by the controller to when it performs certain operations on the bus.

5. The instrument image buffer (item 1) is an area on the display which shows up to 29 characters of the 4300 instrument listen buffer. This window allows the user to view the messages sent to the instrument. The listen buffer is 512 bytes long in the instrument, and the + and - keys on

the front panel can be used to scroll the entire buffer through the window. The (CLR) key will move the window back to the beginning of the buffer, so that the left most character in the display is the first character in the buffer. The solid block that appears on the display marks the end of the current message in the buffer.

6. There are three primary ways to make use of the bus test function. One is to check the status of the signal lines. The second is to break up the bus operation of the instrument into steps. This can be done by activating the bus mode of the instrument before performing any operation. This prevents the instrument from acting upon any messages sent to it. The message will be read into the listen buffer and the display window will be updated but no action will be taken to parse the string and execute the command until the bus test mode is disabled by pressing the ESCAPE key. This breaks the instrument operation up into steps, which allows the operator to verify the reception of the message string before its execution but does not change how the instrument will act upon the command string. The third method is to use the bus test when the instrument responds with the illegal bus command error message. To find out what command in the bus string was not understood by the instrument press the ESCAPE key to clear the error condition and then select the bus test (test 5). At this point the listen buffer display will show the word it did not understand starting in the left most part of the window. Then if more examination of the data is required, the "+", the "-" key, and the (CLR) key could be used to move through the buffer to view other areas.

**6-110. CHOPPER OFFSET TEST.** Perform the test as follows for each input board installed:

1. Connect an oscilloscope probe to input board TP13 (accessible from the top) and set the oscilloscope for 2V per division and 2 mS per division, internal trigger.

2. Connect the Model 2510 DC Range Calibrator (output OFF, output impedance 500K for universal channels, "low" for thermal channels) to the sensor input connector, front or rear, and press ON/OFF to double the calibrator's output. Alternatively, connect a sensor to the input with no applied RF power.

3. Observe the oscilloscope and verify that a square wave <3 V peak to peak, with considerable noise on it, is present.

**6-111. REFERENCE FREQUENCY ACCURACY TEST.**

1. Connect the sensor(s) to the channel (s) to be tested.

2. For each sensor, enter the sensor type and serial number if not entered already, and assign the sensor to the appropriate channel in single channel mode. See the Operation Section,

SENSOR DATA ENTRY key for information on this.

3. Press SHIFT, RECALL, 0, ENTER. This puts the 4300 into single channel mode on channel 1.

4. Select the channel to be checked by pressing SHIFT, SET CH, n, ENTER, where n is the channel number from 1 to 6.

5. Connect the sensor to either the 30 or 50 MHz internal calibrator. If no calibrator is installed, or if the sensors are waveguide sensors, connect it to an external calibrator at 0 or -20 dBm. Press SHIFT, AUTO CAL. Press ENTER if and when prompted by the display and wait for the autocalibration cycle to complete (about 100 seconds if the 30 MHz calibrator is installed).

6. Connect the sensor to an external calibrator which is to be set to the reference frequency shown in Table 6-206, Reference Frequency. See the paragraphs in that section regarding coaxial sensor reference frequency.

7. Vary the output of the generator and take reading in dBm at the power levels shown in Table 6-103 or 6-104, Reference Frequency Accuracy. Verify that the readings agree with the set level with the following accuracy:

Accuracy = Table Entry + Source Error + Shaping Error.  
For the Boonton 25A, the maximum source error is .05 dB; for the Boonton 2520, it is level dependent; see the 2520 specification sheet. For other manufacturers sources, see the applicable specification sheet.

The shaping error is .003 dB if the programmable 30 MHz calibrator is installed, and .04 dB if not (millimeter wave sensors have a shaping error of .04 dB).

**6-112. DC CALIBRATION TEST.** Perform the test as follows for each channel installed:

1. Let the 4300 warm up for at least 20 minutes and connect the Boonton 2510 DC Calibrator to the first channel to be tested.

2. Set the 2510 to range 0 and 500 k ohms.

3. On the 4300, press SHIFT, RECALL, 0, ENTER, and SPCL, 8, ENTER. This places the 4300 in single channel mode, reading raw value.

4. Press SET CH, N, ENTER, where N is the number (1-6) of the channel to be tested.

5. Press FILTER, 5000, ENTER.

6. On the 2510 press ON/OFF to deactivate the signal, as shown on its display. Wait 10 seconds. On the 4300 press ZERO to initiate the zeroing cycle.

**TABLE 6-103. REFERENCE FREQUENCY ACCURACY, COAXIAL SENSORS**

| dBm | Sensor Type             |       |       |       |            |            |
|-----|-------------------------|-------|-------|-------|------------|------------|
|     | 51011<br>51012<br>51013 | 51051 | 51015 | 51033 | 51016<br>* | 51017<br>* |
| -60 | 0.75                    | 0.40  | ---   | ---   | ---        | ---        |
| -55 | 0.40                    | 0.20  | ---   | ---   | ---        | ---        |
| -50 | 0.20                    | 0.11  | 0.75  | ---   | ---        | ---        |
| -45 | 0.09                    | 0.09  | 0.40  | ---   | ---        | ---        |
| -40 | 0.09                    | 0.09  | 0.20  | 0.75  | ---        | ---        |
| -35 | 0.06                    | 0.06  | 0.09  | 0.40  | ---        | ---        |
| -30 | 0.06                    | 0.06  | 0.07  | 0.20  | ---        | ---        |
| -25 | 0.06                    | 0.06  | 0.06  | 0.09  | ---        | ---        |
| -20 | 0.06                    | 0.06  | 0.06  | 0.06  | 0.75       | ---        |
| -15 | 0.06                    | 0.06  | 0.06  | 0.06  | 0.40       | ---        |
| -10 | 0.06                    | 0.06  | 0.06  | 0.06  | 0.20       | 0.75       |
| -5  | 0.06                    | 0.06  | 0.06  | 0.06  | 0.10       | 0.40       |
| 0   | 0.04                    | 0.04  | 0.04  | 0.04  | 0.06       | 0.20       |
| 5   | 0.06                    | 0.06  | 0.06  | 0.06  | 0.06       | 0.10       |
| 10  | 0.06                    | 0.06  | 0.06  | 0.06  | 0.06       | 0.06       |
| 15  | 0.06                    | 0.06  | 0.06  | 0.06  | ---        | 0.06       |
| 20  | 0.06                    | ---   | 0.06  | 0.06  | ---        | 0.06       |
| 25  | ---                     | ---   | 0.08  | 0.08  | ---        | ---        |
| 30  | ---                     | ---   | 0.09  | 0.09  | ---        | ---        |
| 33  | ---                     | ---   | ---   | 0.10  | ---        | ---        |

\*The accuracy numbers are the 4312 (Thermal) Input Modules; when using thermal sensors with 4311 (Universal) Input Modules, triple all table entries that are above (and including) 0.20 dB.

**TABLE 6-104. REFERENCE FREQUENCY ACCURACY, WAVEGUIDE SENSORS**

| dBm | Sensor Type             |                |                |  |
|-----|-------------------------|----------------|----------------|--|
|     | 51035<br>51036<br>51972 | 51037<br>51045 | 51046<br>51047 |  |
| -50 | 0.75                    | 0.80           | 0.90           |  |
| -45 | 0.62                    | 0.75           | 0.82           |  |
| -40 | 0.50                    | 0.70           | 0.71           |  |
| -35 | 0.42                    | 0.62           | 0.66           |  |
| -30 | 0.36                    | 0.56           | 0.61           |  |
| -25 | 0.31                    | 0.51           | 0.56           |  |
| -20 | 0.26                    | 0.46           | 0.51           |  |
| -15 | 0.31                    | 0.51           | 0.56           |  |
| -10 | 0.36                    | 0.56           | 0.61           |  |
| -5  | 0.41                    | 0.61           | 0.66           |  |
| 0   | 0.46                    | 0.66           | 0.71           |  |
| 5   | 0.51                    | 0.71           | 0.76           |  |
| 10  | 0.56                    | 0.76           | 0.81           |  |

7. On the 2510, press ON/OFF to activate the signal.
8. Observe the 4300 display and verify that  $6635 \pm 100$  counts is displayed.
9. Refer to the table and set the 2510 to ranges 1 through 6B and verify that the count tolerance is as specified in Table 6-105.

**TABLE 6-105. DC COUNT TOLERANCE**

| Range | Count Tolerance |
|-------|-----------------|
| 0     | $\pm 100$       |
| 1     | $\pm 35$        |
| 2     | $\pm 25$        |
| 3     | $\pm 20$        |
| 4     | $\pm 20$        |
| 5     | $\pm 20$        |
| 6B    | $\pm 20$        |

10. Repeat steps 4 through 9 for each channel installed.

**6-113. AUTOCALIBRATION TEST (AUTO CAL).**

**NOTE**

This test applies to coaxial sensors when the 30 MHz Calibrator is installed.

Perform the test as follows:

1. Connect the sensor to the channel assigned and connect the RF end to the 30 MHz Calibrator.
2. For each sensor, enter the sensor type and serial number if not entered already, and assign the sensor to the appropriate channel in single channel mode. See the Operation section, SENSOR DATA ENTRY key for information on this.
3. Press SHIFT, AUTO CAL and then press ENTER as prompted. Wait for the autocalibration routine to finish (about 100 seconds). No error message should be displayed. If the display returns to normal with the right hand portion blank, the auto cal has been completed successfully.
4. Repeat steps 1 through 3 for all channels installed.

**6-114. 30 MHz CALIBRATOR PERFORMANCE TESTS.** This verification method uses a Wandel Goltermann EPM-1 milliwatt test set to set the 0 dBm level, and fixed attenuators such as Weinschel Model 1's. The EPM-1 is traceable to the German National Physics Lab, with a basic accuracy at 0 dBm of  $\pm .015$  dB, or NIST. Alternatively, an HP432A power meter may be used along with a DVM; the HP478A-H55 and HP478-H75 calibrations are traceable to NIST. In this case refer to the HP432 instructions for

"Precision Power Measurements", and replace the EPM-1 in the procedures below with the HP432.

**ATTENUATOR CALIBRATION:** If the exact RF attenuation of the pads is not known, it can be measured at DC. The DC attenuation is extremely close to the attenuation at 30 MHz, since the type N attenuators are being used at about 0.2% of their maximum frequency. Alternatively, the pads may be sent to NIST for certification at 30 MHz. To make the measurement, connect a stable DC source through two series 50 ohm resistors to ground. Type N connectors and soldered joints are essential to keep the ground offsets low. Adjust the center point voltage of the resistors for about 2 V, and record as V1. Now connect the pad under test between the two resistors, and measure the voltage at the output of the pad (V2). Calculate  $ATTEN = 20 \log (V2/V1)$ . The tolerance of the 50 ohm resistors does not affect the accuracy of this measurement on a first order approximation since the initial voltage was measured taking their actual values into account. The linearity of the voltmeter is important for this measurement.

**PROCEDURE:**

1. Power up the 4300 and let it warm up for 30 minutes.
2. Press RECALL, 0, ENTER. This puts the 4300 in a standard configuration (serves as an initialization) and sets it to channel 1. Any of the six channels can be used for this procedure, by selecting it from the front panel.
3. Connect a diode sensor (type 51013) to the channel 1 sensor input. Enter the sensor number (1-20) and type, and assign it to channel 1 (or the channel that is to be used). See the Operations Section for the sensor entry procedure. If a sensor is already entered into the instrument and assigned to a channel, this need not be done.
4. Press ZERO and wait for the zero cycle to complete. (The unit should be zeroed every few minutes or so, when making low level measurements.)
5. Press SHIFT, CALIBRATOR LIMIT, 20, ENTER.
6. Connect the equipment as shown in Figure 6-204. On the EPM-1, set the range switch to 0 dBm, and the resistance switch to 50 ohms. Adjust the calibration control on the EPM-1 for a null (0 dBm) indication. The EPM-1 should be nulled for a 0 dBm indication every 5 or 10 minutes.

**NOTE**

In the following procedure, be extremely careful to set the 4300 calibrator level first, then connect it. The EPM-1 is very sensitive to overloads.

7. 0 dBm VERIFICATION: Set the 4300 calibrator to 0 dBm by pressing LEVEL, 0, ENTER. Then connect the equipment as shown in Figure 6-205 and take a reading on the EPM-1. It should be 0 dBm to within the tolerance shown in Table 6-106.

**TABLE 6-106. 30 MHz TOLERANCES**

| Level | Tolerance |
|-------|-----------|
| 0dBm  | .05 dB    |
| +20   | .07       |
| +10   | .07       |
| +8    | .07       |
| +6    | .07       |
| +4    | .07       |
| +2    | .07       |
| -10   | .02       |
| -20   | .02       |
| -30   | .03       |
| -40   | .04       |
| -50   | .07       |

8. +20 dBm VERIFICATION: Set the 4300 calibrator to +20 dBm with the LEVEL key and connect the equipment as shown in Figure 6-206 using the 20 dB attenuator. Take a reading on the EPM-1. The range switch on the EPM-1 may have to be used to get an onscale reading. (The range switch setting gets added to the overall EPM-1 reading.) The reading on the EPM-1 should be 20 - ATTEN where ATTEN is the exact attenuation of the attenuator, to within the tolerance in Table 6-106.

9. +1 to +10 dBm VERIFICATION: Using the same method as for the +20 dBm range, take readings at various power levels as shown in the table, and verify their tolerances. Use attenuators as required to bring the level down to 0 dBm.

10. -10 dBm THROUGH -50 dBm VERIFICATION: Connect the calibrator to the sensor as shown in Figure 6-208, with no attenuator. Turn off the calibrator and let the sensor settle for 40 seconds. Press SHIFT, AUTO CAL and ENTER as prompted by the display. Wait for the autocal cycle to complete (about 2 minutes).

11. Now set the calibrator to 0 dBm and insert the 50 dB attenuator in series with the sensor. Take a reading and call it R. Calculate:

$$R + \text{ATTEN.}$$

The result, neglecting the sign, should be less than the tolerance in Table 6-106. For example, if R is -50.27 and ATTEN is 50.25, the sum is -.02, which is the tolerance listed in Table 6-106. The tolerances at -10 dBm and below are tighter than what might be expected. This is because

the autocalibration has been performed. What is being measured is the difference between the calibrator's internal attenuators and the external test attenuators. The absolute accuracy of the 0 dBm reference has no effect on this measurement.

12. Take similar "R" readings using the 40, 30, 20, and 10 dB attenuators, calculate their tolerances, and verify that they are within those listed in the table.

The tolerances in the table are derived from the requirements on 4300 internal attenuator accuracies, not absolute accuracies; therefore, taking measurements using the nonexact 0 dBm source is valid.

This completes the verification of the 30 MHz calibrator.

#### 6-115. 50 MHz CALIBRATOR PERFORMANCE TEST.

The 50 MHz 0 dBm Calibrator is checked using a Wandel Goltermann EPM-1 Milliwatt Test Set. Alternatively, an HP432 Analog Power Meter can be used in conjunction with a digital voltmeter and an NIST traceable power head (HP478A-H55 or HP478A-H75). In this case, refer to the HP432 manual for "precision power measurements", and replace the EPM-1 in the procedures below with the HP432.

The procedure is as follows:

1. Warm up the equipment for 30 minutes. Connect the EPM-1 power head to the EPM-1 input port as shown in Figure 6-204. Connect the thermistor power head RF port to the 0 dBm output on the EPM-1. Follow the manufacturer's instructions for setting up the instrument as necessary. Adjust the front panel potentiometer for a 0 dBm indication on the analog meter.

2. Disconnect the RF port of the power head from the EPM-1 and connect it to the 4300 50 MHz output. Observe the analog meter. The indication should be 0 +/- .05 dB.

3. Measure the output frequency of the 50 MHz calibrator; it should be 50 +/- 0.5 MHz.

#### 6-116. CHART RECORDER VERIFICATION TEST.

Perform the test as follows:

#### NOTE

The chart recorder outputs are best checked with internal diagnostics that present a ramp to the output. The scaling is a software function and is checked indirectly with previous keyboard test.

1. Set the 4300 power switch to OFF.
2. With the 4300 top cover removed, set the Input Channel Bit switches to activate the chart recorder ramp. See Table 6-202.
3. Set the power switch to ON.
4. Set the oscilloscope horizontal scale to 100  $\mu$ S/Div and connect the probe to the channel RECORDER OUTPUT connector to be tested. Verify that the waveform present is a double ramp: a full-scale 0-10 V ramp, followed by a smaller 0-0.156 V ramp. No discontinuities or erratic steps should be evident.
5. Reset the Input Module bit switches to the appropriate positions.

## SECTION 6-200 ADJUSTMENTS

### 6-201. INTRODUCTION.

The adjustments consist of the following:

1. Power-Up Reset Circuit Adjustment.
2. Initializing Via Bit Switches.
3. Input Channel Adjustments.
4. 30 MHz Calibrator Adjustments.
5. 50 MHz Calibrator Adjustments.
6. DC Cal Factor Entry/Edit.
7. Sensor Data Entry.
8. Autocalibration.
9. AC Reference Frequency Calibration.

### 6-202. POWER-UP RESET ADJUSTMENT.

1. Connect a variac between the 120 volt line and the 4300. Set the 4300 rear panel switch for 120 V, and turn on the 4300.

#### NOTE

For adjustment using a 220/240 V line, set the rear panel switch to the 240 V position.

2. Monitor the AC line voltage going into the 4300 on a voltmeter and also monitor the regulated 5 volts on the control board on a scope. Sync the scope to the line.

3. Adjust the variac so that the regulated 5 VDC is just to the point of "dropping out".

4. Increase the AC voltage by 5 volts as indicated on the meter (10 volts for 240 V operation).

5. Monitor TP5 on the control board and adjust the power up reset pot so that TP5 is just starting to reset, which is indicated by a logic 1 with short pulses of logic 0.

6. Set the line voltage to 105 volts (210 volts for 240 V operation) and verify that the unit is still operating.

7. Power-down the 4300 and disconnect the Variac.

### 6-203. INITIALIZING VIA BIT SWITCHES.

Before adjustments are made to the 4300, initializing procedures should be done as shown below. Refer to Tables 6-201 and 6-202, and Figure 6-201 for the procedures on how to initialize and for descriptions of what is erased/modified with each procedure. Note that if the 4300 is inoperative, a hard reset, which erases most of the memory contents, may fix the problem. If a given channel has a problem, resetting that channel may fix the problem, although the DC calibration data that is printed on the label on the shield will have to be reentered using SPECIAL 3 (this data is also in the envelope under the 4300 cover).

**TABLE 6-201. INITIALIZATION**

| Condition                                                                      | Initialization Procedure |
|--------------------------------------------------------------------------------|--------------------------|
| 1. Control board has been repaired and/or some sensor data has been corrupted. | Hard reset               |
| 2. Input channel(s) have been repaired, or need routine calibration.           | Input channel reset      |
| 3. 30 MHz calibrator has been repaired or needs routine calibration.           | Soft reset               |
| 4. 4300 malfunction.                                                           | Hard reset               |
| 5. Power supply has been repaired.                                             | Soft reset               |

**6-204. INPUT CHANNEL ADJUSTMENTS.** The input boards are calibrated to a DC source, from 9 microvolts to 4.5 VDC, differential, with an impedance 500 K ohms (universal boards, P/N 04311001\*) or 1.8 K ohms, approximately, for thermal boards (P/N 04311003\*). The Boonton 2500 or 2510 DC Calibrators provide these voltages from a Boonton type sensor connector. The input channel is reset as follows (calibration is voided).

1. Power up the 4300.

2. Set the bit switches as shown:

(1 or more input boards may be reset at once; set each board as required.)

| Control Board | Input Board | Rear Panel |
|---------------|-------------|------------|
| 4 Off         |             |            |
| 3 Off         | All Open    | All Closed |
| 2 On          |             |            |
| 1 Off         |             |            |

3. Power down, wait three seconds, then power back up and wait another three seconds.

4. Put the input board switches back to their original positions (see Table 6-205).

5. Power down and up twice, waiting three seconds each time as before. All the DC Gain constants will be set to nominal values, and any erroneous data will be erased. This also sets the input channel to range 0, the most sensitive range. (Strictly speaking, the input channel would not have to be reset if it were known that the previous calibration data was within certain limits, but the reset operation starts the calibration procedure from a known baseline). The control board Bit switch 2 enables (unprotects) the calibration.

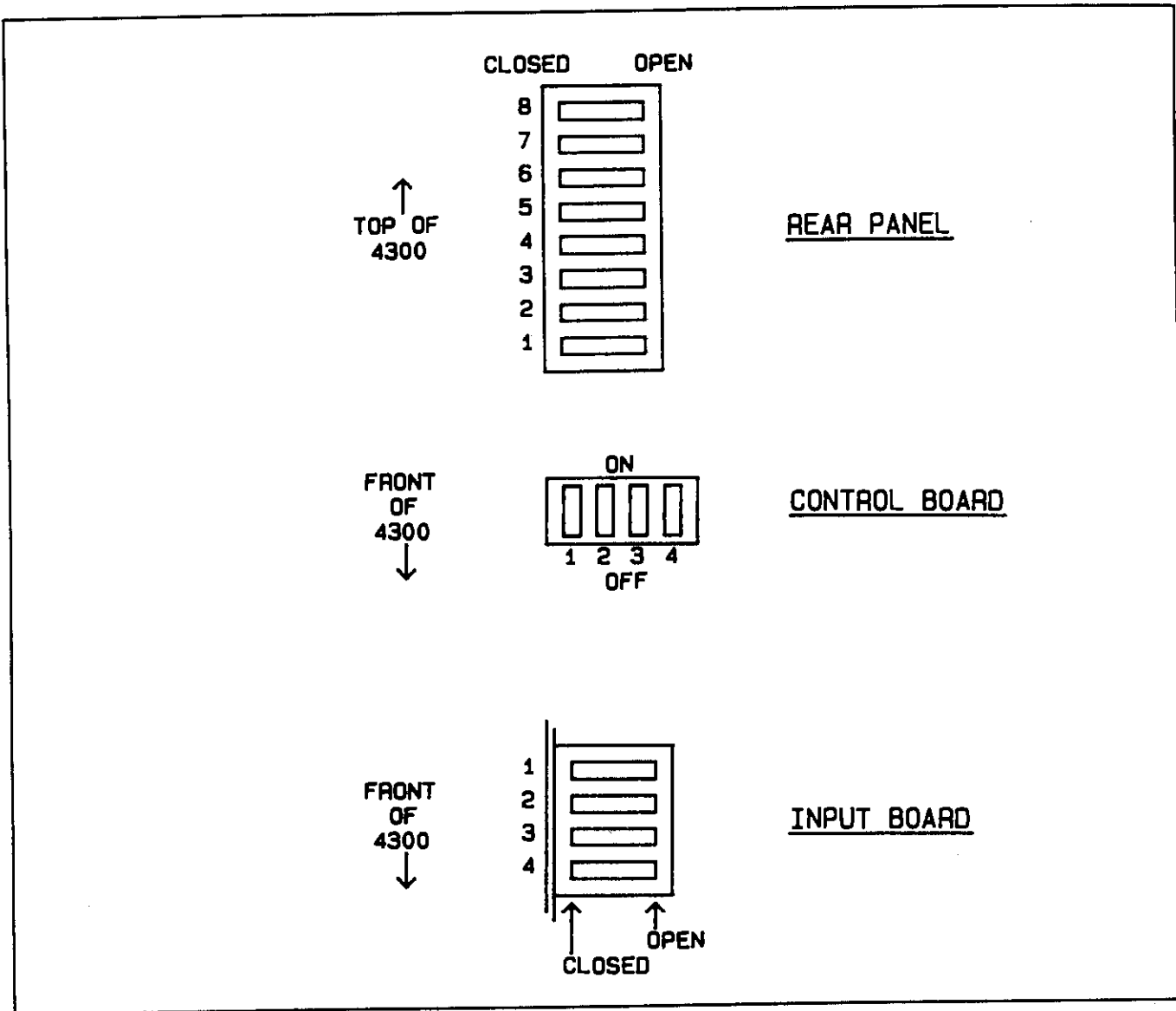

Figure 6-201. 4300 Bit Switch Diagram

3. **Chopper Offset Check.** Connect the Boonton 2510 DC calibrator to the sensor input and set the impedance to 500 K for universal channels (04311001\*) or "low" for thermal channels (04311003\*). Press the ON/OFF button on the 2510, to turn off its output it on. Monitor TP13 on the Input Channel on the scope (2 mS per division and 1V per division). There will be a noisy square wave at 240 Hz (sync the scope on TP14 or pin 4 of the chopper assembly if desired, or, sync to the line). The amplitude should be less than 2 V p-p. If it is not, it will be necessary to remove the input board and adjust the chopper, as shown below.

4. **Chopper Adjustment.** Power down the 4300 and remove the input channel. Two screws on the bottom attach the shield to the bus board and one screw attaches at the rear

panel. Also, disconnect the two pigtail leads that connect to the front sensor connector (red goes to red and black goes to white). Put the board on the extender card and reconnect the 2510. Power up and monitor TP2 on the scope (2 mS per division and 1 V per division). TP2 is accessible through the 1" hole in the shield. Center the two pots (mechanically) on the chopper (two holes near the bracket assembly), and also the "tilt" pot R46 on the input board. Then adjust the two chopper pots in equal opposite directions until a minimum signal appears at TP2. Adjust the tilt pot for flat slopes. Then touch up the chopper pots once more, this time monitoring TP13 on the input board (this is the filtered signal).

Put the board back in the unit and check the chopper voltage again using the 2510.



**TABLE 6-202. BIT SWITCH FUNCTIONS**

| <b>REAR PANEL</b>    |                                                                                                                                                                                                                                                                                                                               |                                                                                                                                                                                                                                                                                                                                                |
|----------------------|-------------------------------------------------------------------------------------------------------------------------------------------------------------------------------------------------------------------------------------------------------------------------------------------------------------------------------|------------------------------------------------------------------------------------------------------------------------------------------------------------------------------------------------------------------------------------------------------------------------------------------------------------------------------------------------|
| <b>Position</b>      | <b>Closed</b>                                                                                                                                                                                                                                                                                                                 | <b>Open</b>                                                                                                                                                                                                                                                                                                                                    |
| 1                    | LF terminates Listen mode.                                                                                                                                                                                                                                                                                                    | CR terminates Listen mode.                                                                                                                                                                                                                                                                                                                     |
| 2                    | LF terminates Talk mode.                                                                                                                                                                                                                                                                                                      | LF does not terminate Talk mode (can be used with Pos 3).                                                                                                                                                                                                                                                                                      |
| 3                    | CR terminates Talk mode.                                                                                                                                                                                                                                                                                                      | CR does not terminate Talk mode (can be used with Pos 2).                                                                                                                                                                                                                                                                                      |
|                      | Note: To send no terminators, open position 2 and 3.                                                                                                                                                                                                                                                                          |                                                                                                                                                                                                                                                                                                                                                |
| 4                    | MATE disabled.                                                                                                                                                                                                                                                                                                                | MATE Enabled.                                                                                                                                                                                                                                                                                                                                  |
| 5                    | Not used.                                                                                                                                                                                                                                                                                                                     |                                                                                                                                                                                                                                                                                                                                                |
| 6                    | Unprotect sensor entry; data may be entered from the front panel. The Control board switch position 2 must be set to 1 also to unprotect. If desired, the control board switch may be left set to 1, so that the covers need not be removed to change sensor data. The unit is shipped with both switches set for protection. | Protect sensor data entry or modification from the front panel.                                                                                                                                                                                                                                                                                |
| 7                    | Range the display (decimal point) along with the input board hardware range (amplifier range). This is the standard mode.                                                                                                                                                                                                     | Range the display (decimal point) with the displayed value. The readout in watts or dBm is fixed to 4 digits.                                                                                                                                                                                                                                  |
| 8                    | Normal power up; parameters are retained.                                                                                                                                                                                                                                                                                     | Soft reset on power up; sets to channel 1, dB CF set to 0, etc. Equivalent to pressing "RECALL, 0, ENTER" (basic initialization). Note: If the control board switch position 1 is "on" at the same time, a hard reset will occur (master reset, erasing all sensor data, etc).                                                                 |
| <b>CONTROL BOARD</b> |                                                                                                                                                                                                                                                                                                                               |                                                                                                                                                                                                                                                                                                                                                |
| <b>Position</b>      | <b>Off</b>                                                                                                                                                                                                                                                                                                                    | <b>On</b>                                                                                                                                                                                                                                                                                                                                      |
| 1                    | Hard reset disabled.                                                                                                                                                                                                                                                                                                          | Hard reset on power up; this is a master reset which erases all sensor data and operating parameters. The input board DC gain constants are not affected. The rear panel switch position 8 must be set to open for a hard reset to occur. A hard reset is generally done when repairs on the control board have corrupted the memory contents. |
| 2                    | Protect input board DC gain constant modification from the front panel, and protect recalibration of the 30 MHz Calibrator from the front panel. The 30 MHz Calibrator also has a jumper on it which must be in place to recalibrate. The jumper is removed at the factory. Protect the 14-point AC calibration, Special #5.  | Unprotect input channel DC gain constant modification and 30 MHz calibrator recalibration from the front panel. See note at left regarding jumper. Unprotect the 14-point AC calibration, Special #5.                                                                                                                                          |
| 3                    | Protect sensor data entry from the front panel.                                                                                                                                                                                                                                                                               | Unprotect sensor data entry from the front panel. May be left in the unprotect mode if desired. Position 6 on the rear panel must also be set to closed to unprotect.                                                                                                                                                                          |
| 4                    | Not used.                                                                                                                                                                                                                                                                                                                     |                                                                                                                                                                                                                                                                                                                                                |

**TABLE 6-202. BIT SWITCH FUNCTIONS (Cont.)**

| INPUT CHANNEL(S)<br>Position |   |   |   | (C = Closed, O = Open)<br>Function                                                                                           |
|------------------------------|---|---|---|------------------------------------------------------------------------------------------------------------------------------|
| 1                            | 2 | 3 | 4 |                                                                                                                              |
| C                            | C | C | C | Normal operating position for universal channels; Sets default filter to 2.8 seconds on range 0.                             |
| C                            | C | C | O | Normal operating position for thermal channels; Sets default filter to 4.8 seconds on range 0.                               |
| C                            | C | O | C | Diagnostics: RAM test. See Troubleshooting.                                                                                  |
| C                            | C | O | O | Diagnostics: Chart recorder test. See Troubleshooting.                                                                       |
| C                            | O | C | C | Diagnostics: Decoder test. See Troubleshooting.                                                                              |
| C                            | O | C | O | Diagnostics: 1ADTEST. See Troubleshooting.                                                                                   |
| C                            | O | O | C | Diagnostics: 2ADTEST. See Troubleshooting.                                                                                   |
| C                            | O | O | O | Adjustments: See Input Board Adjustments.                                                                                    |
| O                            | C | C | C | Adjustments: See Input Board Adjustments.                                                                                    |
| O                            | C | C | O | Adjustments: See Input Board Adjustments.                                                                                    |
| O                            | C | O | C | Puts settled reading on chart recorder output as a level; Default filter set to 2.8 seconds on range 0 (universal channels). |
| O                            | C | O | O | Puts settled reading on chart recorder output as a level; Default filter set to 4.8 seconds on range 0 (thermal channels).   |
| O                            | O | C | C | Not used.                                                                                                                    |
| O                            | O | C | O | Not used.                                                                                                                    |
| O                            | O | O | C | Not used.                                                                                                                    |
| O                            | O | O | O | Resets Input Board. See Input Board Adjustments.                                                                             |

5. **DC Gain Adjustment.** Set the bit switch on the input channel to all closed. Power down and power up again twice, waiting 3 seconds each time the unit is powered up. This puts the input board in regular measurement mode.

- 1 Open
- 2 Closed
- 3 Closed
- 4 Closed

6. Press SHIFT, RECALL, 0, ENTER. This will put the 4300 in a standard configuration on channel 1.

7. Set the 4300 to the channel number that is being calibrated by pressing SHIFT, SET CH, N, ENTER, where N is the channel number (1-6).

8. Turn off the output of the Boonton 2510 DC Calibrator. Wait 5 seconds for the input board to stabilize.

9. Press ZERO on the 4300 and wait for the unit to complete its zero cycle, as indicated on the display.

10. Set the bit switch on the input board to:

11. Press SPECIAL, 4, ENTER. This will put the 4300 in DC Cal mode.

12. Set the 2510 to range 5 and release the zero button on it, enabling the signal. On the 4300, press ENTER. The 4300 will take a measurement on range 5 and store this value. This value is used to generate "ADZERO", which is a downscale adjustment of the A/D converter. Wait 6 seconds or so for the cycle to complete.

13. Set the 2510 to range 4, and set the bit switch on the input board to:

- 1 Closed
- 2 Open
- 3 Open
- 4 Open

14. Press ENTER. The 4300 will take a measurement on range 4, and generate "ADZERO", which can be extracted or modified with special function 3, at a later time. An allowable range for ADZERO is  $\pm 13$ .

15. Set the bit switch on the input board to:

- 1      Open
- 2      Closed
- 3      Closed
- 4      Open

This is the basic setting for calculating the DC gain constants.

16. Press the ON/OFF button on the 2510, to disable the signal. Wait 10 seconds for the 4300 to stabilize, and press ZERO. Wait for the completion of the zeroing cycle.

17. Set the 2510 to range 1 and press ON/OFF to enable the signal. Wait 2 seconds for the 4300 to stabilize, then press ENTER. Note: After the 4300 is zeroed, it will begin to drift. The time between zeroing and calibration of range 1 should be as short as possible.

The 4300 will calibrate on range 1 and after a few seconds, should indicate the result. The raw value as shown on the display should be  $6635 \pm 15$  counts, as shown in Table 6-203 below. Range 0 is not calibrated, since the noise on that range is greater than the nonlinearity.

**TABLE 6-203. DC CALIBRATION TOLERANCE**

| Range | Tolerance      |
|-------|----------------|
| 0     | +/- 150 Counts |
| 1     | 20             |
| 2     | 4              |
| 3     | 2              |
| 4     | 2              |
| 5     | 2              |
| 6B    | 2              |

18. Set the 2510 to range 2, and press ENTER. The 4300 should calibrate on range 2 and conform to the tolerance in Table 6-203.

19. Perform calibration on ranges 3 through 6B in the same manner. Do not calibrate ranges 0 or 6A.

20. Press ESCAPE, SPECIAL, 8, ENTER, FILTER, 2000, ENTER. This takes the 4300 out of DC Cal mode and back into standard measurement mode, showing the units in raw value, with the filter at 2 seconds.

21. Press the ON/OFF button on the 2510 to disable the signal and press ZERO on the 4300.

22. Enable the output of the 2510, cycle it through the ranges, and note the 4300 display. The raw value should be as indicated in Table 6-203, along with the tolerances. Occasionally, the board may latch onto a range that is one too high, because of range overlap. In this case, disable the source momentarily to let the 4300 range down. If any range does not provide the proper indication, rezero the 4300 and perform the steps above for the range(s) that fail. The unit should be rezeroed just before calibrating ranges 1 or 2.

**NOTE**

If calibration is to be checked but not reset, use Table 6-204, which is somewhat wider in tolerance to accommodate the typical variation in 2510's.

**TABLE 6-204. DC VERIFICATION TOLERANCE**

| Range | Tolerance      |
|-------|----------------|
| 0     | =/- 150 Counts |
| 1     | 30             |
| 2     | 10             |
| 3     | 10             |
| 4     | 10             |
| 5     | 10             |
| 6B    | 10             |

23. Press SHIFT, SET RANGE, 5, ENTER. Set the 2510 to range 5 and note the reading. Now set the 2510 to range 4. The new reading should be one tenth the reading on range 5, within 2 counts. If not, perform the calibration again. Example: Range 5 = 6637 and range 4 = 662. One tenth of 6637 is 664 (round off). The range 4 value is one tenth of this.

24. Press AUTO RANGE. Note: If any of the ranges are to be calibrated again, be sure the instrument is in autorange mode.

25. Press SPECIAL, 3, ENTER. This puts the 4300 in the DC Edit mode where the DC gain constants can be read and recorded. Press ENTER to advance to each range, and record the gain factors. The last number on the display is the ADZERO value. Record this also. Write the numbers on a label and slide the label between the boards onto the shield, or keep the data in the envelope under the 4300 cover. Press ESCAPE and dBm to get back into dBm mode.

This completes the calibration of the input channel. Set the bit switch on the input board to that shown in Table 6-205, depending on the type of input channel. Set the Bit switch on the Control Board to all zeroes, or as desired, to protect the calibration and sensor data. See Table 6-202.

**TABLE 6-205. NORMAL CHANNEL BIT SWITCH SETTINGS**

|   | Universal | Thermal |
|---|-----------|---------|
| 1 | Closed    | Closed  |
| 2 | Closed    | Closed  |
| 3 | Closed    | Closed  |
| 4 | Closed    | Open    |

**6-205. 30 MHz CALIBRATOR ADJUSTMENTS.**

The 30 MHz Calibrator is calibrated in the 4300 frame, using commands from the keyboard. Calibration data is stored in nonvolatile RAM on the 30 MHz Digital board. The Digital board and the 30 MHz Generator casting are a matched pair, and, if removed or replaced, must remain together.

There are two methods of calibration, both of which are described below. The first uses an external reference that can be adjusted from -60 to +20 dBm, and the technique is that of matching the 4300 calibrator to the reference. The second method uses a single level reference at 0 dBm, and fixed calibrated attenuators. The 0 dBm reference can be either a source, which the 4300 calibrator is matched to, or a meter, which measures the output of the 4300 calibrator. The "meter" approach is described here using the Wandel Goltermann EPM-1 because of its good performance.

Early versions of the software (C\* and earlier) require calibration of the -60 dBm point, as described below. In later versions, the -60 dBm point is extrapolated from the adjustment at -50 dBm. This eliminates the need for a 30 MHz amplifier. Contact Boonton for the procedure to update the software if desired.

**6-206. METHOD 1, (VARIABLE REFERENCE METHOD)**

1. Remove the top cover of the 4300 and the aluminum shield on the left side of the instrument. Remove the extender card as required to gain access to the control board switch. Set the Bit switches as follows:

| Control Board | Input Channels      | Rear Panel |
|---------------|---------------------|------------|
| 1 Off         | Leave as is, see    | All Closed |
| 2 On          | section on Input    |            |
| 3 On          | channel adjustments |            |
| 4 Off         |                     |            |

2. Solder a jumper on the 30 MHz Digital Board ( at the extreme right of the 4300), between E1 and E2. These test points are accessible without removing the 30 MHz generator if care is used. This unprotects the nonvolatile RAM and allows calibration.

3. Set the calibrator to 0 dBm by pressing LEVEL, 0, ENTER (the shift key need not be pressed for number entries). Let the instrument warm up for 30 minutes.

4. Press RECALL, 0, ENTER. This puts the 4300 in a standard configuration (serves as an initialization) and sets it to channel 1. Any of the six channels can be used for this procedure, by selecting it from the front panel.

5. Connect a 51075 sensor to the channel 1 sensor input (A 51013 sensor may be used with reduced accuracy.) Enter the sensor number (1-20) and type, and assign it to channel 1 (or the channel that is to be used). See the Operation section for the sensor entry procedure. If a sensor is already entered into the instrument and assigned to a channel, reassign it to the same channel by setting the channel, then by pressing ASSIGN, N, ENTER, where N is the sensor number (1-20). This erases previous autocalibration data for that channel/sensor which may be invalid.

6. Press ZERO and wait for the zero cycle to complete. (The unit should be zeroed every few minutes or so, when making low level measurements.)

7. Connect the equipment as shown in Figure 6-202 and switch the coaxial switch to the 4300 calibrator. Cables should not be used between the calibrator and the sensors. Use rigid 90 degree couplers. The amplifier gain is not important since it is used for comparison measurements only.

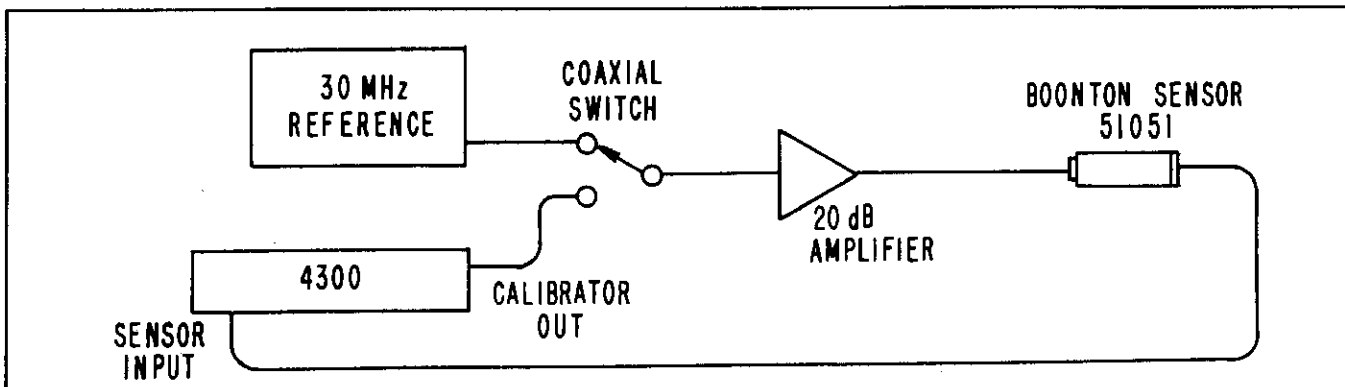

Figure 6-202. Calibration at 30 MHz Below 0 dBm

**NOTE**

The amplifier is not required on units with the later software (D\* and later).

8. Press the keys as shown below:  
 FILTER, 800, ENTER — (Selects 0.8 second filter)  
 SPECIAL, 8, ENTER — (Selects the raw data mode for greater resolution)  
 SPECIAL, 1, ENTER, 2, ENTER — (Selects settled reading mode)  
 SPECIAL, 6, ENTER — (Selects 30 MHz calibration routine)

9. CALENDAR ENTRY. Enter the month (1 to 12) as prompted by the display and press ENTER. Then enter the year (2 digits). Then press the + key. This starts the input channel measuring. The calendar dates are prompted only the first time the unit is powered up; if a unit is powered up twice in a row, the calibration is still valid but the dates are not entered the second time.

10. MIDSCALE CORRECTION. At this point the 4300 will prompt the operator for a number between -15 and 15 which sets a midscale correction factor on all ranges (the region 3 to 7 dB below a full scale reading on any given range). Note: This adjustment applies only to software versions DL and higher (May 1988). Press ENTER if it is desired to not change the number at this time. The factor changes the output reading by .005 dB per count at 5 dB below full scale, and progressively less at levels that deviate from this. The number is stored in nonvolatile RAM.

In general, this is the last step in the calibration process (see step 19), done after the endpoints of the range are set. However, access to this adjustment is put at the beginning of the SPECIAL 6 routine for ease of use when several passes at the number are required. Once the number has been entered and ENTER is pressed to save it, the ESCAPE key may be used to exit the SPECIAL 6 routine, and the midscale correction factor will be saved.

11. PEAKING. The calibrator is now set to about +3 dBm with the control loop saturated. Adjust C12 for a maximum reading on the meter. Note: To gain access to C12, input channels 5 and 6 have to be removed. If the calibrator is installed in the rear output, access cannot be obtained without removing the calibrator. Generally, C12 only requires adjustment when repairs have been made to the section near C12. If necessary, the calibrator may be calibrated with the Generator Section (casting) physically out of the 4300, still connected with the ribbon cable. An additional ground wire to the 4300 chassis will be necessary, connected by lifting screws on both the 4300 and the generator housing. This is necessary to prevent DC ground drops from adding to the control voltage. When the output has been peaked, press ENTER.

The calibrator is now set to -60 dBm (-50 dBm with the later software). Each 10 dB step is adjusted individually. Adjusting is done with 6 keys as shown (the shift key need not be pressed):

- |        |                                                                |
|--------|----------------------------------------------------------------|
| +      | Increases output by about .003 dB                              |
| -      | Decreases output by about .003 dB                              |
| .      | Increases output by about .03 dB                               |
| 0      | Decreases output by about .03 dB                               |
| 4      | Increases output by about 0.3 dB                               |
| 1      | Decreases output by about 0.3 dB                               |
| ESCAPE | Returns the 4300 to measurement mode (can be done at any time) |

12. -60 dBm Adjustment (not required with the later software). With the coaxial switch positioned to the reference, set the reference to -60 dBm and note the reading on the display and the range. Then turn the coaxial switch to the 4300 calibrator and adjust the level by using the keys as listed above so that the readings are the same. Switch back and forth between the 4300 and the reference as required. Note: Not only must the raw data reading match, but the range as well, because it is possible to be off by as much as one range and still have the raw data match. When the readings match, press ENTER. This enters the calibration data for that level and advances the calibrator to the next 10 dB step (-50 dBm).

**NOTE**

If it is desired to bypass a certain range without writing over the old calibration data, press SCROLL when on that range. When the desired range is reached, press + to start the input board measuring. If ENTER is pressed instead of SCROLL, the calibration data for that range will be erased if the + key was not pressed.

13. -50 Adjustment. Set the reference to -50 dBm and switch the coaxial switch to the reference. Take a reading as described in the -60 dBm adjustment above and then adjust this range. Each time a new range is selected, the + key must be pressed to begin measurement. See the note above regarding range skipping.

14. -40 dBm to +10 dBm Adjustments. Remove the amplifier from the path if it was installed (early software versions only). Progressively adjust each 10 dB step as in previous steps, up to +10 dBm. Leave the unit on the +20 dBm range.

15. +20 dBm Adjustment. Insert a 10 dB attenuator in series with the sensor as shown in Figure 6-203. Adjust this range as done for other ranges, and press ENTER as the last step, to store the calibration results. The 4300 will exit from

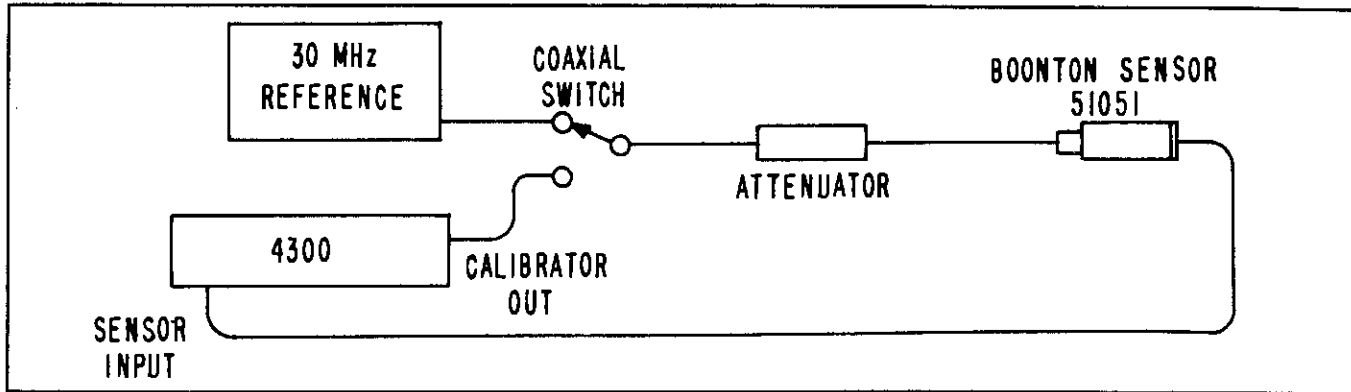

Figure 6-203. 30 MHz Calibration Above 10 dBm

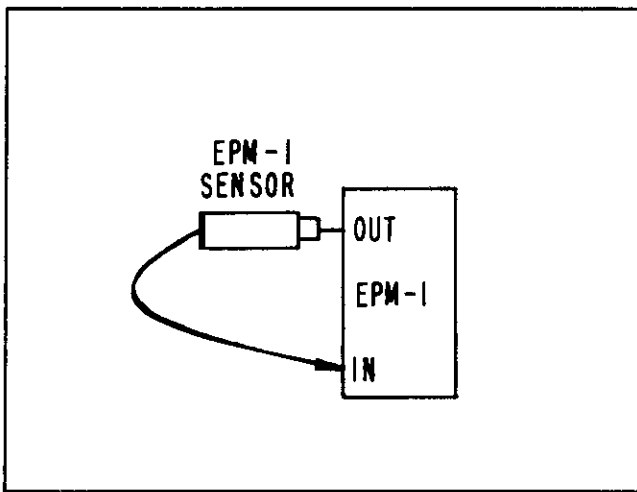

Figure 6-204. Zeroing the EPM-1

the calibration routine as this is the last point.

16. Downscale Adjustment. The instrument should still be in the raw value mode and in the settled reading mode. Set up the equipment as shown in Figure 6-202, but do not use the amplifier. Set the 4300 and the reference to -20 dBm. Compare readings of both by alternating the coaxial switch. If they are more than two counts different, perform the above calibration again.

Now set both units to -29 dBm. Adjust the pot R11 on the top of the 30 MHz Generator assembly (casting) so that the readings match. If the Generator is assembled into the 4300 for a rear output, this pot is accessible only by removing the Generator. The generator should be mounted in the front output position temporarily with the two screws on the bottom to obtain a good ground.

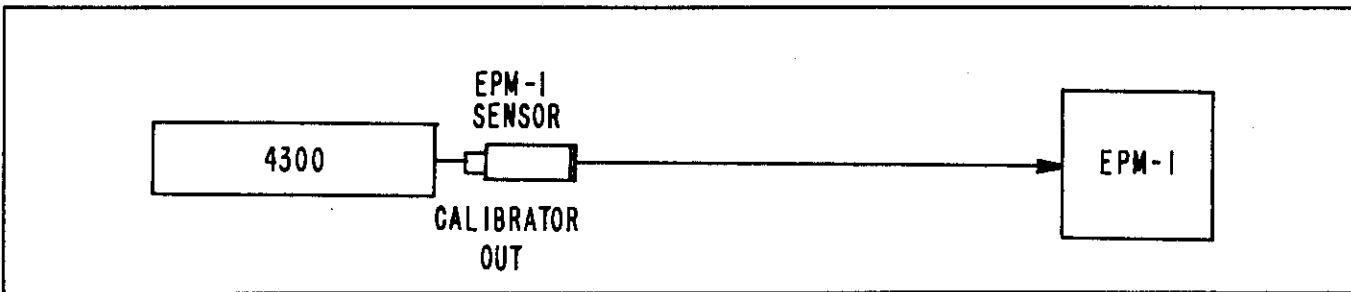

Figure 6-205. 0 dBm Measurement

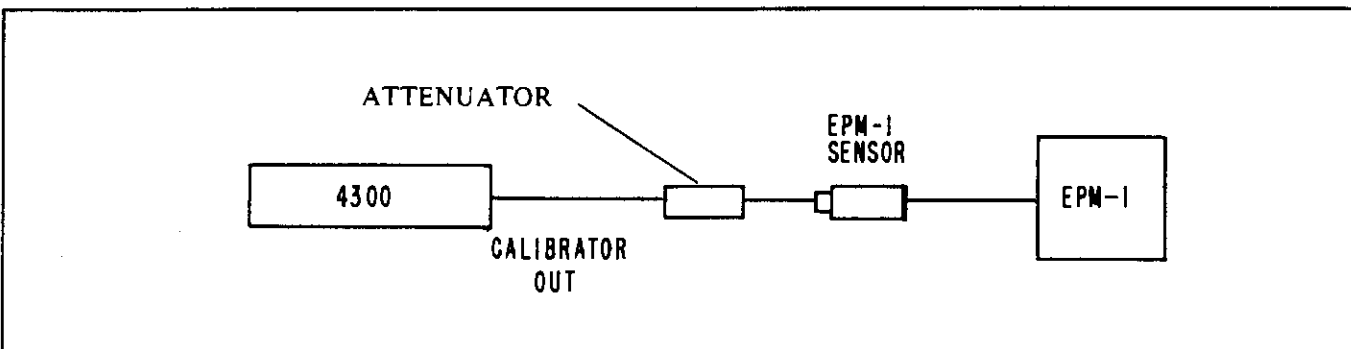

Figure 6-206. Attenuated Measurements

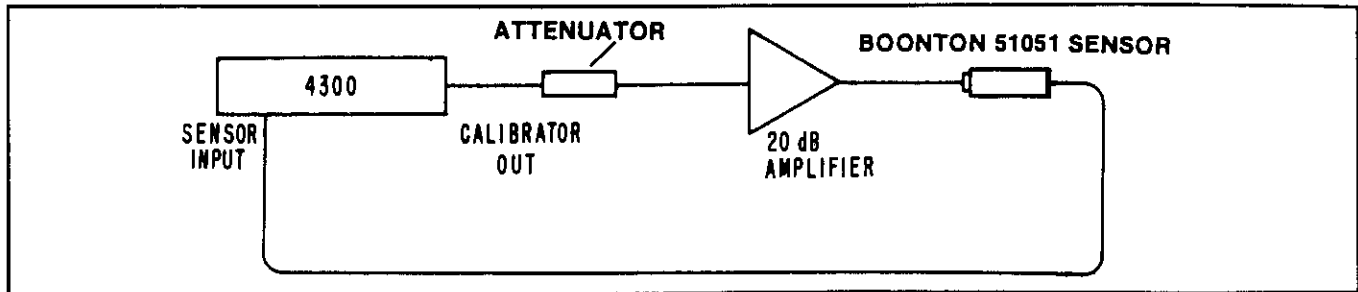

Figure 6-207. Measurement at -60 dBm

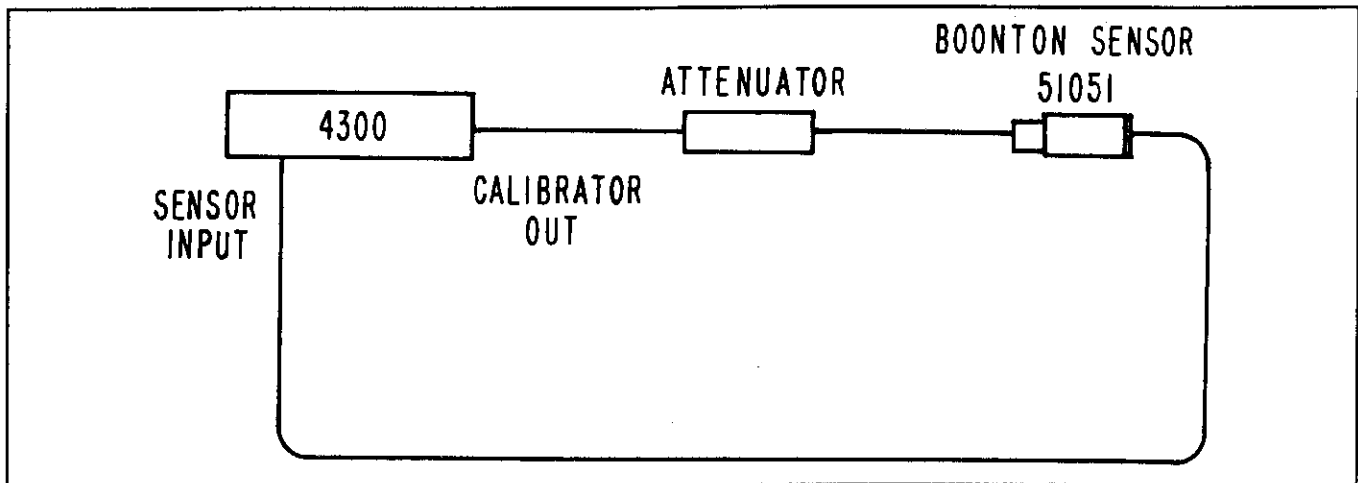

Figure 6-208. Wraparound Measurement

**NOTE**

A downscale adjustment that is more than 1/8 of a turn will generally change the upscale calibration. On a unit that has just been repaired, the best way to calibrate is to skip by the lower range adjustments and do a downscale adjustment first, then go back and adjust each range.

17. **UPSCALE CHECK.** Set the 4300 and the reference to -20 dBm. Press dBm. Compare readings again in dBm. If there is more than .01 dB difference, recalibrate the 10 dB steps again.

18. **MIDSCALE ADJUSTMENT.** Set the 4300 and the reference to -25 dBm. Compare readings again. If the readings are different by .01 dB or more, press SPECIAL 6 and perform the midscale correction adjustment as described in Step 10, above. This adjustment does not affect any of the previous adjustments.

19. **FINAL CHECK.** Power down the 4300 and wait a few seconds, then power-up. Press SHIFT, CALIBRATOR LIMIT, 20, ENTER. Using the Calibrator LEVEL key, and SHIFT and ENTER, take readings on both the 4300 and the reference at 5 dB intervals from -60 to +20 dBm. Use the 10

dB attenuator when taking measurements above +10 dBm. When checking points at or below -40 dBm, be sure to zero the 4300 every few minutes. Use the amplifier for checking the -60 dBm point (early software). If any reading differs by more than .02 dB, recalibrate the unit.

20. **JUMPER.** Disconnect the jumper on the Digital board if it is desired to protect the unit from accidental recalibration. Set the control board Bit switch to all zeros, or as desired, see Table 6-202. This concludes the adjustment of the 30 MHz Calibrator, method 1.

**6-207. METHOD 2, FIXED ATTENUATOR METHOD.**

1. This method uses a Wandel Goltermann milliwatt test to set the 0 dBm level, and fixed attenuators such as Weinschel Model 1's. The EPM-1 is traceable to the German National Physics Lab, with a basic accuracy at 0 dBm of  $\pm .015$  dB or to NIST. Alternatively, an HP432A power meter may be used along with a DVM instead of the EPM-1. The HP478A-H55 and HP478-H75 power head calibrations are traceable to NIST. In this case, refer to the HP432 instructions for "Precision Power Measurements", and substitute the HP432 for the EPM-1 in the steps below.

2. **ATTENUATOR CALIBRATION.** If the exact attenuation of the pads is not known, they can be measured at DC. The DC attenuation is extremely close to the attenuation at 30 MHz, since the type N attenuators are being used at about 0.2% of their maximum frequency. Alternatively, the attenuators may be sent to NIST for certification at 30 MHz. To make the measurement, connect a stable DC source through two series 50 ohm resistors to ground. Type N connectors and soldered joints are essential to keep the ground offsets low. Adjust the center point voltage of the resistors for about 2V, and record as V1. Now connect the attenuator under test between the resistors, and measure the voltage at the output of the attenuator (V2). Calculate  $ATTEN = 20 \log (V2/V1)$ . The tolerance of the 50 ohm resistors does not affect the accuracy of this measurement on a first order approximation since the initial voltage was measured taking their actual values into account. The linearity of the voltmeter is important for this test.

3. **PROCEDURE.** Remove the top cover of the 4300 and perform the steps shown in Method 1 above, (up to the -50 dBm adjustment), except do not connect the equipment.

4. Connect the equipment as shown in Figure 6-204. On the EPM-1, set the range switch to 0 dBm, and the resistance switch to 50 ohms. Adjust the calibration control on the EPM-1 for a null (0 dBm) indication.

The calibrator is now set to -60 dBm (-50 dBm for the later software version). Each 10 dB step is adjusted individually. Adjusting is done with 6 keys as shown (the shift key need not be pressed):

|        |                                                                |
|--------|----------------------------------------------------------------|
| +      | Increases output by about .003 dB                              |
| -      | Decreases output by about .003 dB                              |
| .      | Increases output by about .03 dB                               |
| 0      | Decreases output by about .03 dB                               |
| 4      | Increases output by about 0.3 dB                               |
| 1      | Decreases output by about 0.3 dB                               |
| ESCAPE | Returns the 4300 to measurement mode (can be done at any time) |

5. **0 dBm ADJUSTMENT.** Press SHIFT until the unit scrolls to the 0 dBm range. Then connect the equipment as shown in Figure 6-205. Note: the EPM-1 is sensitive to overloads above about 1 dBm; be sure the calibrator is set correctly before connecting. Now press the 6 keys as listed above to adjust the calibrator to exactly 0 dBm. Then press ENTER once, and ESCAPE.

6. **+10 dBm ADJUSTMENT.** With the EPM-1 disconnected from the calibrator, press SPECIAL, 6, ENTER. Press SHIFT until the instrument is on the +10 dBm range. Connect the equipment as shown in Figure 6-204 and zero the EPM-1. Then connect the equipment as shown in Figure 6-206 using the 10 dB attenuator. Adjust the level using the

6 keys listed in previous sections until the reading on the EPM-1 is 10.00 - ATTEN, where ATTEN is the attenuation of the fixed attenuator. (The range switch on the EPM-1 may have to be used; the range switch setting gets added to the meter reading.) Press ENTER once, and ESCAPE.

7. **+20 dBm ADJUSTMENT.** With the EPM-1 disconnected from the calibrator, press SPECIAL, 6, ENTER. Press SHIFT until the instrument is on the +20 dBm range. Then connect the equipment as shown in Figure 6-206 using the 20 dB attenuator. Adjust the level using the 6 keys listed in previous sections until the reading on the EPM-1 is 20.00 — ATTEN. (The range switch on the EPM-1 may have to be used; the range switch setting gets added to the meter reading). Press ENTER once, and ESCAPE

#### NOTE

During calibration at levels above +10 dBm, the calibrator limit function does not affect (limit) the output, but when SPECIAL 6 is exited, and the calibrator is to be checked, the calibrator limit must be set to +20 dBm. See the CALIBRATOR LIMIT key in the Operation section.

8. **DOWNSCALE ADJUSTMENT.** Connect the equipment as shown in Figure 6-206, using the 1 dB attenuator. Press ESCAPE to leave the calibration routine. Press LEVEL, 1, ENTER. Adjust the pot R11 on the top of the 30 MHz Generator assembly (casting) so that the reading on the EPM-1 is equal to 1.00 - ATTEN where ATTEN is the exact attenuation of the attenuator. If the Generator is assembled into the 4300 for a rear output, this pot is accessible only by removing the Generator. The generator should be mounted in the front output position temporarily with the two screws on the bottom to obtain a good ground. Note: The downscale adjustment may affect the upscale levels (0, -10, -20, etc.). Perform Step 5 above as required.

9. **-60 dBm ADJUSTMENT (Early software only).** Connect the equipment as shown in Figure 6-207, using the 60 dB attenuator or stacked attenuators equal to 60 dB nominal. Cables should not be used between the calibrator and the sensors. The absolute amplifier gain is not important, since it is used for comparison of two measurements only, but it must be repeatable. Press LEVEL, 0, ENTER. Take a reading and call it A. Now set the level to -60 dBm (LEVEL, 60, -, ENTER) and remove the attenuator from the path. Press SPECIAL, 6, ENTER to get into the calibration routine. Press + to begin measurement, and adjust the level using the 6 keys previously mentioned so that the reading is equal to A + ATTEN + (-60). For example,



|               |   |                   |
|---------------|---|-------------------|
| Reading A     | = | -40.45            |
| ATTEN         | = | 60.40             |
| Desired Level | = | + -60.00          |
| Adjust for    |   | <u>-40.05</u> dBm |

Then press ENTER once, and ESCAPE.

10. -50 dBm ADJUSTMENT. Connect the equipment as shown in Figure 6-208 and perform this calibration the same as the -60 dBm adjustment, using the 50 dB attenuator and setting the calibrator to -50 dBm. When SPECIAL 6 is executed, it will be necessary to skip over the -60 dBm range by pressing SHIFT (early software only). If ENTER is pressed instead, the -60 dBm calibration will be erased.

11. -40 dBm TO -10 dBm ADJUSTMENTS. Perform these range adjustments the same as above, in order. Press ENTER when the -10 dBm point is completed, then ESCAPE.

12. MIDSCALE ADJUSTMENT. Take a reading at -5dBm as before, using a 5 dB attenuator. If this point is in error by .01dB or more, press SPECIAL 6, and perform a midscale correction adjustment as described in Step 10 of Section 6-206. This adjustment does not affect any of the full scale or downscale adjustments. Then perform the final check as shown in Step 19 of Section 6-206.

13. JUMPER. Disconnect the jumper on the Digital board if it is desired to protect the unit from accidental recalibration. Set the control board Bit switch to all zeros, or as desired, see Table 6-202. This concludes the adjustment of the 30 MHz Calibrator, method 2.

**6-208. 50 MHz CALIBRATOR ADJUSTMENT.** The 50 MHz 0 dBm calibrator is calibrated using a Wandel Goltermann EPM-1 Milliwatt Test Set. Alternatively, an HP432 Analog Power Meter can be used in conjunction with a digital voltmeter and an NIST traceable power head. In this case, refer to the HP432 manual for "precision power measurements", and replace the EPM-1 in the procedures below with the HP432.

The adjustment pot for the 50 MHz calibrator is in the top of the 4300 if it is installed in the front output connector, and on the bottom if mounted in the rear output connector.

The procedure is as follows:

1. Warm up the equipment for 30 minutes. Connect the EPM-1 power head to the EPM-1 input port, and connect the thermistor power head RF port to the 0 dBm output on the EPM-1. Follow the manufacturers instructions for setting up the instrument as necessary. Adjust the front panel potentiometer for a 0 dBm indication on the analog meter.

2. Disconnect the RF port of the power head from the EPM-1 and connect it to the 4300 50 MHz output. Observe the analog meter. Adjust R4 on the 50 MHz calibrator for a 0 dBm indication.

3. Measure the output frequency of the 50 MHz calibrator; it should be 50 +/-0.05 MHz.

If either the level or the frequency cannot be adjusted within specifications, follow the two steps below.

1. Remove the calibrator from the 4300 and leave it connected to the power supply. Remove the cover from the calibrator and power up. Monitor pin 3 of the op amp with a scope of DC voltmeter and adjust R4 for approximately -4 VDC. With the RF port terminated into a 50 ohm load (such as the frequency counter), monitor the junction of L3 and R15 with a scope. Adjust C4 and C12 for 600 mV p-p at 50 MHz. The controls may interact.

2. Replace the cover and put the calibrator back into the 4300. Connect the EPM-1 power head to the calibrator. Readjust R4 for a 0 dBm indication.

**6-209. DC CAL FACTOR ENTRY AND EDIT.** After repairs have been made on the input channels, or a soft error has occurred due to inadvertent shorting, a reset of the input channel is necessary and the DC calibration factors that are printed on the channel module must be reentered. Alternatively, the module can be recalibrated. If any modifications/repairs have been made to the input amplifiers or A/D, recalibration is necessary; see Input Channel Adjustments. The entry procedure of the old data is as shown below.

Go to single channel mode and select the appropriate channel. Note the numbers on the label and enter according to the keystrokes below. Note: ranges 0 and 1 use the same data points.

| Press                               | Display Will Show      |
|-------------------------------------|------------------------|
| SPECIAL, 3, ENTER                   | Range 0 and DC CAL mmm |
| (4 digit number for range 0), ENTER | Range 1 and DC CAL nmm |

Continue for each range. Then enter the ADZERO number with the same procedure. The 4300 will escape and return to measurement mode.

**6-210. SENSOR DATA ENTRY.** Part of the overall 4300 adjustments include the entry of sensor serial number, type, linearity data and high frequency calibration data. Refer to the Operation section for the sensor entry procedure, and enter or check the data as required for each sensor. In the case of coaxial sensors, when the 30 MHz Programmable Calibrator is installed, the linearity data need not be entered, but instead the Autocalibration cycle should be executed.

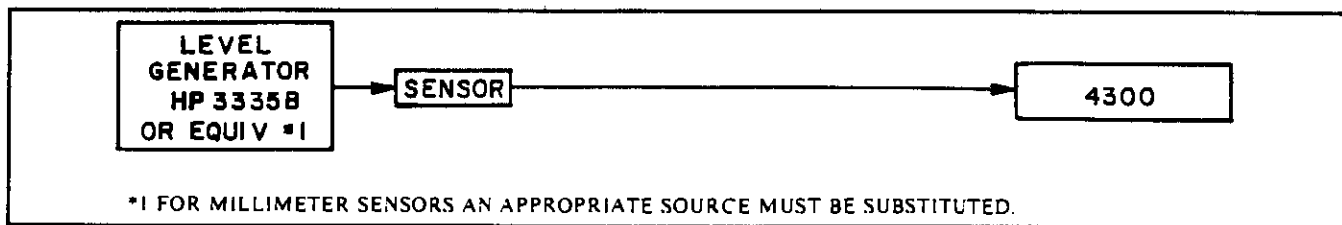

Figure 6-209. Basic Reference Frequency Calibration

**6-211. AUTOCALIBRATION.** Also included as part of overall adjustments is the autocalibration cycle, which applies to coaxial sensors when the 30 MHz programmable calibrator is installed. The calibration is a final step after the sensor assignments have been done, since channel errors are also nulled out and stored on the channel with this procedure. Sensor reassignment erases this data. Refer to the CALIBRATOR AUTOCAL key in the Operation section for the procedure and perform it for each of the coaxial sensors.

**6-212. AC REFERENCE FREQUENCY CALIBRATION.** When there is no programmable calibrator installed, the sensor must be calibrated for linearity at some reference frequency, generally 1 MHz for coaxial sensors. The calibration is done by modifying the 14-point linearity data stored in the sensor data bank. The data supplied with the sensor can be used; however, if this data is suspect or it is desired to recalibrate using a known AC source, the procedure below should be followed. This also applies to waveguide sensors, which cannot be used with the programmable calibrator.

The 14-point data involves a gain correction number for each of the 7 ranges (from 4200 to 5800) which is calculated based on a measurement near the top of each range (upscale correction). Then there is also an offset which is calculated at about 1/4 of full-scale (downscale correction). See Theory section for the use of these numbers. After calculation of these numbers, they are entered into the sensor data bank using the SENSOR ENTRY key, as shown below.

For the 51015 and 51033 high power sensors, which go up to +30 and +33 dBm respectively, the 30 MHz internal calibrator does not calibrate to the top end, but rather extrapolates. The extrapolation error is perhaps .04 dB; this 14-point calibration procedure will correct for this, and autocalibration can still be used, which is applied on top of the 14-point calibration. However, the accuracy of the sensors is reduced at the higher levels anyway, at medium and high frequencies, so the extrapolation error is not a large contributor of error. The procedure for Reference Frequency Calibration is shown below:

**1. Initialization.** Power up the equipment and let it warm up for 30 minutes. Connect the equipment as shown in Figure

6-209. Use no cables between the sensor and the generator. Set the Bit switch on the 4300 rear panel, position 6, to closed, and set the internal Bit switch (on the control board), position 3, to "on". See Table 6-202 and Figure 6-201 for the Bit switch functions. This unprotects the sensor data and allows modification from the front panel.

Set the 4300 to a standard configuration by pressing SHIFT, RECALL, 0, ENTER. Then set the channel to be used for calibration (not necessarily the one to be used in the final application) by pressing SHIFT, SET CH, N, ENTER, where N is the channel (1-6).

Enter the sensor type and serial number into one of the sensors, 1 to 20, if not done already, by pressing SENSOR ENTRY, M, ENTER, where M is the sensor number (1-20). Then follow the prompts and press ESCAPE after the serial number has been entered. The upscale and down scale data can be left as their old values, if previously entered, or may be left as zeros, or set to 0 (downscale) and 5000 (upscale). See the SENSOR ENTRY key in the Operation section for more detail.

Assign the sensor to the channel by pressing SENSOR ASSIGN, N, ENTER, where N is the sensor number.

**2. Attenuator Calibration.** If the exact attenuation of the pads is not known, they can be measured at DC. The DC attenuation is extremely close to the attenuation at 30 MHz, since the type N attenuators are being used at about 0.2% of their maximum frequency. Alternatively, the pads may be sent to NIST for certification at 30 MHz. To make the measurement, connect a stable DC source through two series 50 ohm resistors to ground. Type N connectors and soldered joints are essential to keep the ground offsets low. Adjust the center point voltage of the resistors for about 2V and record as V1. Now connect the pad under test between the resistors, and measure the voltage at the output of the pad (V2). Calculate  $ATTEN = 20 \log (V2/V1)$ . The tolerance of the 50 ohm resistors does not affect the accuracy of this measurement on a first order approximation since the initial voltage was measured taking their actual values into account.

**3. Reference Frequency Setting.** Set the level generator to 1 MHz for coaxial diode sensors, and 10 MHz for thermal

sensors. (Any frequency in the sensor's range below 1 GHz can serve as a reference for calibration, as long as an amplifier is available at that frequency, or as long as the source can go up to the top of the sensor's range. The sensors are extremely flat below 1 GHz so the frequency of calibration is not important). For waveguide sensors, set the level generator to that shown in Table 6-206.

**TABLE 6-206. WAVEGUIDE SENSOR REFERENCE FREQUENCIES**

| Sensor | Reference Frequency |
|--------|---------------------|
| 51035  | 22 GHz              |
| 51036  | 33                  |
| 51972  | 33                  |
| 51037  | 40                  |
| 51045  | 40                  |
| 51046  | 60                  |
| 51047  | 94                  |

4. **Upscale Calibration.** With no power applied to the sensor, press ZERO and wait for the zero cycle to complete (zeroing should be done once a minute or so when calibrating on ranges 1 and 2).

Set the level generator for the levels shown in Table 6-207 using the upscale calibration points, according to the sensor type. Start from the lowest power and proceed upward until the level generator in use can no longer supply the proper level (the higher levels are done with the amplifier in the steps below). For each point, verify that the channel is on the proper range, and if not, set it using the RANGE SET key. Take readings in dBm and for each point calculate the change to be added to the upscale gain factor by:

$$\text{Upscale Change} = (\text{Upscale Calibration Point} - \text{Actual reading}) \times 172.$$

For example, if the generator output is set to an upscale point of -10.00 dBm and the actual reading is -10.15, the upscale gain factor will have to be changed by  $0.15 \times 172 = 26$  counts. The reading is low so the count will have to be in the positive direction. Take all the readings first, then change all the upscale factors at once, as follows:

To change the factors, press the SENSOR ENTRY key and scroll through the sensor number and serial number by pressing ENTER repeatedly, to get access to the upscale factors. When the range 0 number is reached, mentally modify the number on the display by the change calculated above and enter the new number.

**NOTE**

Range 0 and range 1 use the same upscale factor, derived from a reading on range 1. A zero in the upscale number is to be interpreted as a 5000. Some of the waveguide sensors are not measured on either ranges 0 or 1, but use the gain correction derived from the measurement on the range 2 for these ranges. Table 6-207 gives this information.

**TABLE 6-207. UPSCALE AND DOWNSCALE CALIBRATION POINTS**

| Sensor                              | Range | Upscale Cal Point | Downscale Cal Point |
|-------------------------------------|-------|-------------------|---------------------|
| 51010,<br>51011,<br>51012,<br>51013 | 1     | -44 dBm           | -50 dBm             |
|                                     | 2     | -34               | -40                 |
|                                     | 3     | -24               | -30                 |
|                                     | 4     | -14               | -20                 |
|                                     | 5     | 0                 | -10                 |
|                                     | 6     | 16                | 6                   |
| 51015                               | 1     | -34               | -40                 |
|                                     | 2     | -24               | -30                 |
|                                     | 3     | -14               | -20                 |
|                                     | 4     | -4                | -10                 |
|                                     | 5     | 10                | 0                   |
|                                     | 6     | 26                | 16                  |
| 51033                               | 1     | -24               | -30                 |
|                                     | 2     | -14               | -20                 |
|                                     | 3     | -4                | -10                 |
|                                     | 4     | 6                 | 0                   |
|                                     | 5     | 20                | 10                  |
|                                     | 6     | 30                | 26                  |
| 51016                               | 1     | -10               | -16                 |
|                                     | 2     | 0                 | -6                  |
|                                     | 3     | 10                | 4                   |
| (Ranges 4 through 6 not used)       |       |                   |                     |
| 51017                               | 1     | 0                 | -6                  |
|                                     | 2     | 10                | 4                   |
|                                     | 3     | 20                | 14                  |
| (Ranges 4 through 6 not used)       |       |                   |                     |
| 51051                               | 0     | -53               | -58                 |
|                                     | 1     | -43               | -48                 |
|                                     | 2     | -33               | -38                 |
|                                     | 3     | -23               | -28                 |
|                                     | 4     | -12               | -18                 |
|                                     | 5     | 3                 | -5                  |
| 6                                   | 10    | 6                 |                     |
| 51035                               | 1     | -45               | -50                 |
|                                     | 2     | -34               | -40                 |
|                                     | 3     | -24               | -30                 |
|                                     | 4     | -12               | -20                 |
|                                     | 5     | 0                 | -8                  |
|                                     | 6     | 10                | 4                   |

**TABLE 6-207. UPSCALE AND DOWNSCALE CALIBRATION POINTS (Cont.)**

| Sensor          | Range | Upscale Cal Point | Downscale Cal Point |
|-----------------|-------|-------------------|---------------------|
| 51036,<br>51972 | 2     | -44               | -50                 |
|                 | 3     | -34               | -38                 |
|                 | 4     | -20               | -28                 |
|                 | 5     | -10               | -16                 |
|                 | 6     | 10                | -4                  |
| 51037           | 2     | -44               | -50                 |
|                 | 3     | -34               | -38                 |
|                 | 4     | -20               | -28                 |
|                 | 5     | -10               | -18                 |
|                 | 6     | 10                | 0                   |
| 51045           | 2     | -38               | -44                 |
|                 | 3     | -28               | -35                 |
|                 | 4     | -16               | -25                 |
|                 | 5     | -4                | -13                 |
|                 | 6     | 10                | 0                   |
| 51046           | 1     | -46               | -50                 |
|                 | 2     | -34               | -41                 |
|                 | 3     | -24               | -31                 |
|                 | 4     | -12               | -20                 |
|                 | 5     | 0                 | -8                  |
|                 | 6     | 10                | 3                   |
| 51047           | 1     | -45               | -49                 |
|                 | 2     | -35               | -42                 |
|                 | 3     | -24               | -32                 |
|                 | 4     | -13               | -21                 |
|                 | 5     | -2                | -10                 |
|                 | 6     | 10                | 1                   |

For example, in the case above, suppose that the upscale on range 1 was 4900 at the time of the initial measurement. The new number is  $4900 + 172$  or 5072, which is entered at this time, on range 0 and 1. Terminate each entry with ENTER (not ENTRY), which advances the 4300 to the next range. Modify the factors for each range as required.

Press ESCAPE to return to the measurement mode and take the full scale readings again. If any readings are not correct, repeat the sequence. The readings will be closer each time.

**5. Downscale Calibration.** Remove the power from the sensor, wait 10 seconds or so for the sensor to settle, press ZERO, and wait for the zero cycle to complete.

With the equipment still connected as shown in Figure 6-209, set the level generator to the Downscale Calibration Points, listed in Table 6-207, and take readings in dBm on calibration points as far up as the generator will go, but not above the highest range that was calibrated for upscale (the upscale on each range must be done before the downscale). Verify that the channel is on the proper range for each point, and if not, set it using the RANGE SET key. For each point, calculate the change to be added to the downscale factor by:

$$\text{Downscale Change} = (\text{Downscale Calibration Point} - \text{Actual Reading}) \times 23.$$

When all the downscale calibration points have been measured, press the SENSOR ENTRY key and change the downscale factor on each range by the appropriate amount, as was done for the upscale factors. As for the upscale points, range 0 should use the same data as range 1, and some of the waveguide sensors use the same point on ranges 0, 1,

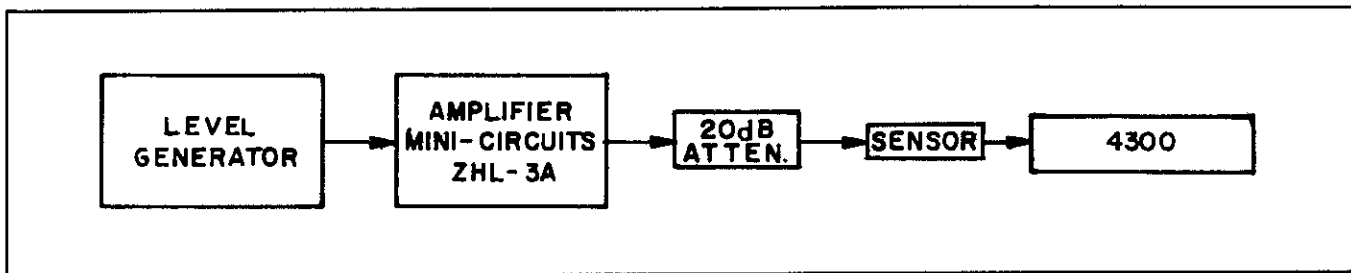

Figure 6-210. High Level Reference Frequency Calibration, Step 1

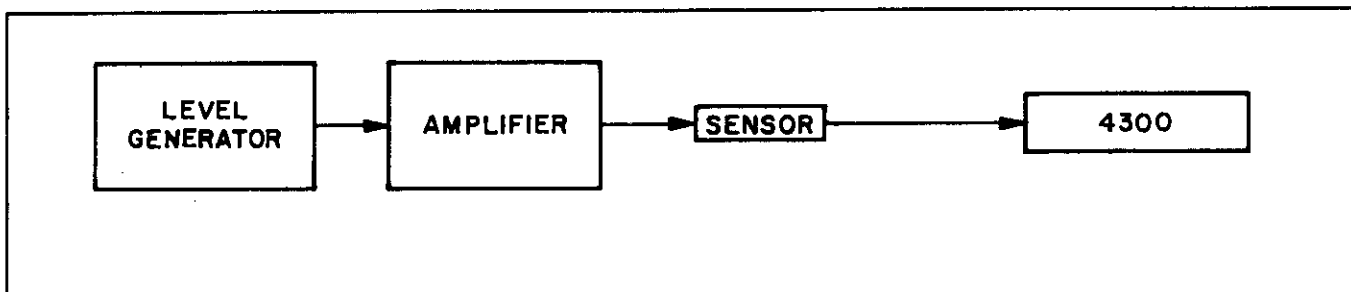

Figure 6-210. High Level Reference Frequency Calibration, Step 2

and 2.

Press ESCAPE to return to the measurement mode, and take the downscale readings again. In general, these downscale points will have to be adjusted several times until they are correct, because the formula above is only approximate and varies from sensor to sensor. The downscale calibration procedure is thus one of successive approximation.

**6. Upscale Calibration With the Amplifier.** The calibration points that were above the generator limitation are calibrated with the procedure below. Connect equipment as shown in Figure 6-210. Turn off the source and let the sensor settle for 20 seconds. Press ZERO and wait for the 4300 to complete its zeroing cycle.

Starting from the lowest upscale calibration point in Table 6-207 that could not be calibrated without the amplifier (if any), calibrate these points as shown below.

Set the level generator so that the 4300 reads approximately the given calibration point minus 20 dB. For example, in Table 6-207, if it calls out to be calibrated at +18 dBm and the generator only goes to +13 dBm, set the generator so that the 4300 reads as close to (18-20) or -2 dBm as possible. Take a reading and call it A.

Disable the source and remove the attenuator, to agree with the configuration shown in Figure 6-211. Do not use any cables between the sensor and the amplifier. Enable the source. Now the power will be roughly +18 dBm, in this example, per the requirement. The exact power in general will be:

$$\text{Amplifier Output} = A + \text{ATTEN}$$

where the attenuation (ATTEN) has been measured previously. The power need not be exactly equal to the upscale calibration point, but should be within  $\pm 1$  dB, and it must be known, as calculated with the above equation.

Now, knowing that power, the 4300 is adjusted to read that power, using the upscale factor as before. The upscale factor is adjusted by an amount equal to:

$$\text{Upscale Change} = (\text{Amplifier Output} - \text{Actual reading}) \times 172$$

where the amplifier output was calculated in the steps above.

Do this for each range that could not be calibrated without

the amplifier, and then, back in measurement mode, check the readings to see that they match the calculated amplifier output(s). For each point, first set the level generator with the attenuator in the circuit, then remove it to take the measurement.

**7. Downscale Calibration with the Amplifier.** Turn off the source and let the sensor settle for 10 seconds. Press ZERO and wait for the 4300 to complete its zeroing cycle.

Starting from the lowest downscale calibration point in Table 6-207 that could not be calibrated without the amplifier (if any), calibrate these points as follows.

Connect the equipment as shown in Figure 6-210. Set the level generator so that the 4300 reads approximately the given calibration point minus 20 dB. For example, in Table 6-207 if it calls out to be calibrated at +15 dBm and the generator only goes to +13 dBm, set the generator so that the 4300 reads as close to (15-20) or -5 dBm as possible. Take a reading and call it B.

Disable the source and remove the attenuator, to agree with the configuration shown in Figure 6-211. Now, the power will be roughly +15 dBm, as required. The exact power in general will be:

$$\text{Amplifier Output} = B + \text{ATTEN}$$

Now, knowing that power, the 4300 is adjusted to read that power, using the downscale factor as before. The downscale factor is adjusted by an amount equal to:

$$\text{Downscale Change} = (\text{Amplifier Output} - \text{Actual reading}) \times 23,$$

where the amplifier output was calculated in previous steps.

Do this for each range that could not be calibrated without the amplifier, and then, back in measurement mode, check the readings to see that they match the calculated amplifier output(s). For each downscale point, first set the level generator with the attenuator in the circuit, then remove the attenuator to take the measurement. In general, the downscale points will have to be calibrated several times in succession.

This completes the AC reference frequency calibration. If it is desired to protect the sensor data from accidental corruption, set either the control board Bit switch position 3 to zero, or set the rear panel Bit switch position 6 to OPEN, or both. Reassign the sensor to another channel as required for operation.

## SECTION 6-300

# TROUBLESHOOTING

### 6-301. ACCESS TO BOARDS.

Refer to Section 2, Installation, for information on removing boards and modules and gaining access to them.

### 6-302. GENERAL.

An instrument malfunction will generally be evident from the front panel. Or, the unit may not be able to be calibrated. If either of these conditions is present, first follow the steps below:

Initialize the instrument with a soft reset from the rear panel. See Table 6-202 and the section titled "Initializing Via the Bit Switches" in the Adjustments section for the procedure. This may correct problems that occurred due to memory dropouts.

If the soft reset does not correct the problem, perform a hard reset, as shown in the Adjustments section. A hard reset may fix a condition that was caused by intermittent shorts etc., that caused a memory dropout. A hard reset will also erase all sensor calibration data and all instrument setups, so it should be done at the repair person's discretion.

If a hard reset does not correct the problem, refer to the Theory of Operations section and then to the Troubleshooting charts, Figure 6-301, 6-302, and 6-303. Proceed to the test indicated according to the problem.

### 6-303. TEST 100 (POWER SUPPLY).

The power supply consists of voltage regulators A8U1, A8U2, and A8U3 on the heatsink assembly and various filter capacitors and resistors on the control board.

Check voltages on TP9, TP10, and TP12 for +5, +15, and -15 VDC,  $\pm 5\%$ . TP11 is provided as a convenient ground point. Refer to the appropriate paragraph below for high or low voltage conditions. If the voltages are OK and the 4300 is still nonoperating, proceed to TEST 101.

High voltage on any one (or more) of these TPs may indicate a shorted regulator, an open resistor on the control board, or a shorted protection diode (CR2, CR6, CR7).

Low voltage on any one (or more) of these TPs may indicate a short somewhere in the frame. Remove all the channel modules and the 30 MHz calibrator. If the voltage returns to normal, suspect one of the modules. Also, check for solder flakes, loose screws, etc., in the unit.

If the input voltages to the regulator are greater than 2 volts above the nominal regulated voltages and the output is still low, replace the regulator in question. If there is still a problem, check the resistors in regulator region.

### 6-304. TEST 101 (POWER-UP/RESET).

This circuitry provides the  $\mu P$  with non-maskable-interrupt (NMI-), HALT- and RESET- signals. When the line voltage drops below limits set by potentiometer R9, all 3 signals should go low. During power up and down, they follow the sequence as shown on the control board schematic.

When powered-up, proper operation is indicated when NMI RESET-, and HALT- lines are logic high. Electrical "noise" on any of these signal lines may cause the  $\mu P$  to respond erratically. The following conditions should be met:

1. Check for approximately 5.2 V at the junction of zener diode CR4 and resistor R16.
2. Using a variable AC power source, vary the line voltage from 75% to 100% of nominal and check at TP5 for NMI-toggling between logic zero and one. If it does not, replace U22.
3. With low line, check that TP6, (RESET-) and TP7, (HALT-) have also gone logic low. If not, replace U23. Also, reset R9 as outlined in the Adjustments section of this manual.
4. With nominal AC line, if HALT- is low and NMI- is high, this may indicate that the  $\mu P$  has halted due to a stimulus from another source.
5. HALT- and RESET- should come up about 1/2 second after NMI-, during power-up.

If the power-up reset circuits appear to be OK and there is still a problem with the unit, proceed to TEST 102 (CLOCKS).

### 6-305. TEST 102 (CLOCKS).

The clock consists of a Y1, a crystal oscillator module with TTL compatible output, and U20, a binary counter. Clock signals are supplied throughout the instrument and any failure would generally show up as a completely nonfunctional unit.

1. Check Y1 pin 8 for a 16 MHz square wave (62.5 nS period).

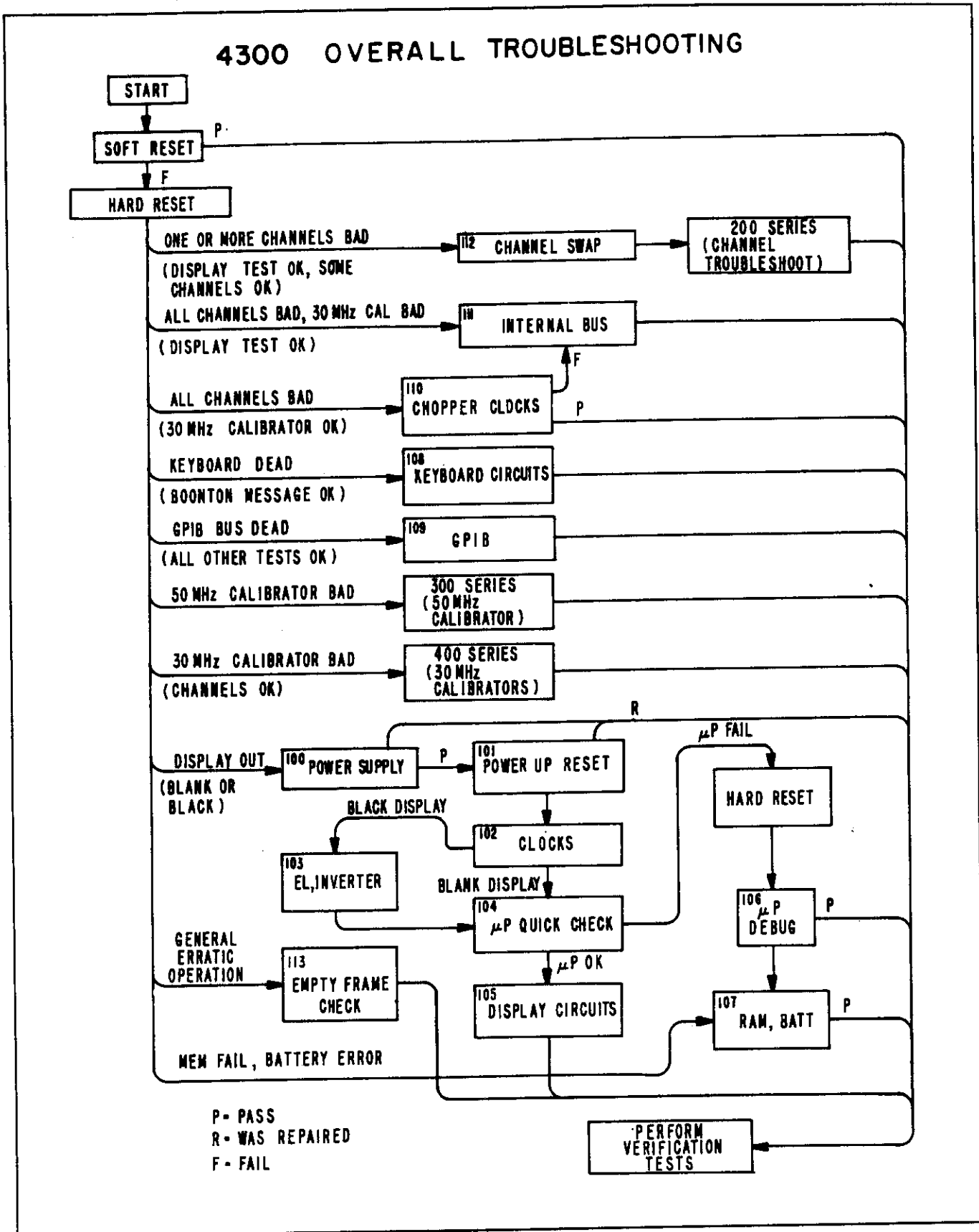

Figure 6-301. Overall Troubleshooting

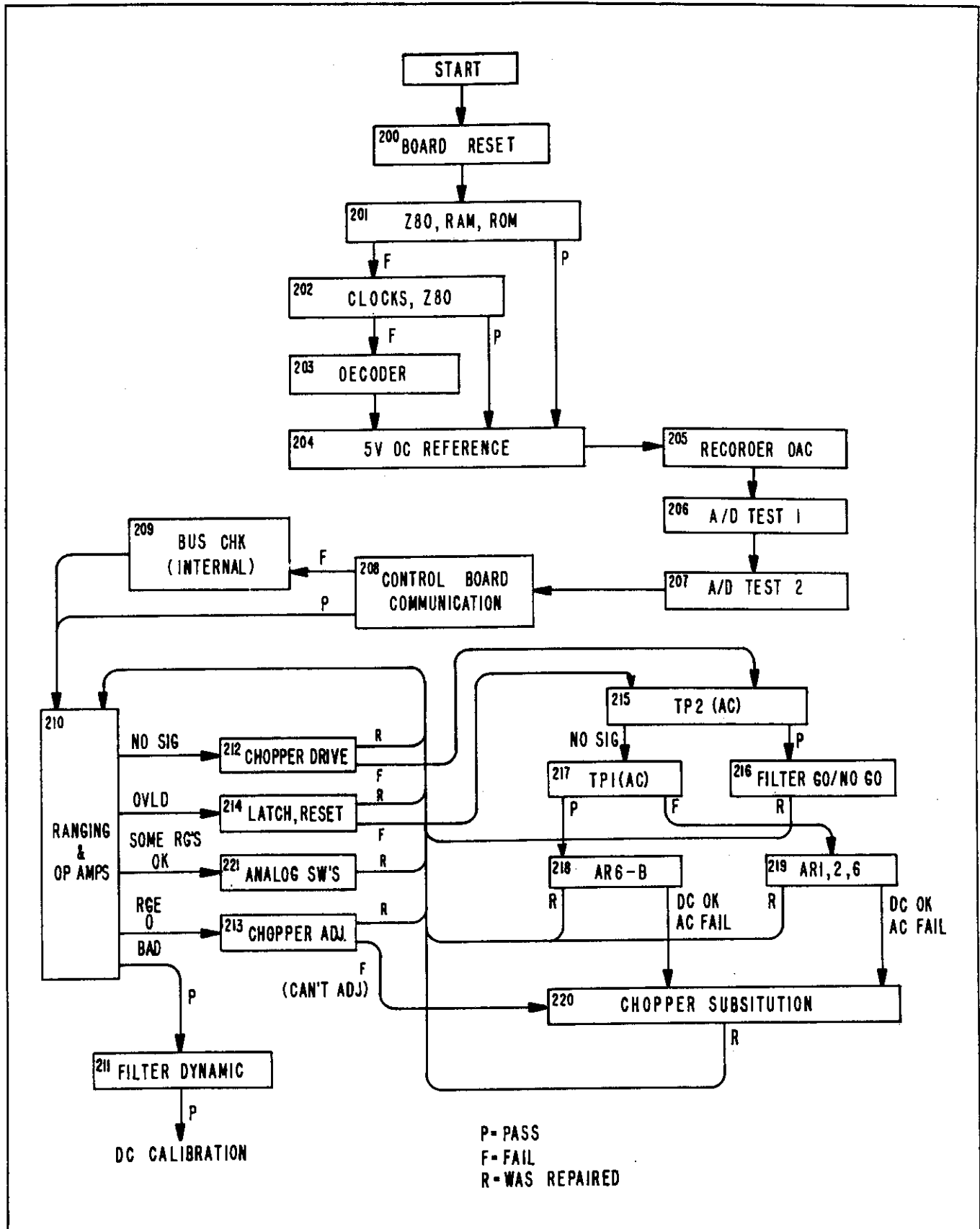

Figure 6-302. Input Channel Troubleshooting



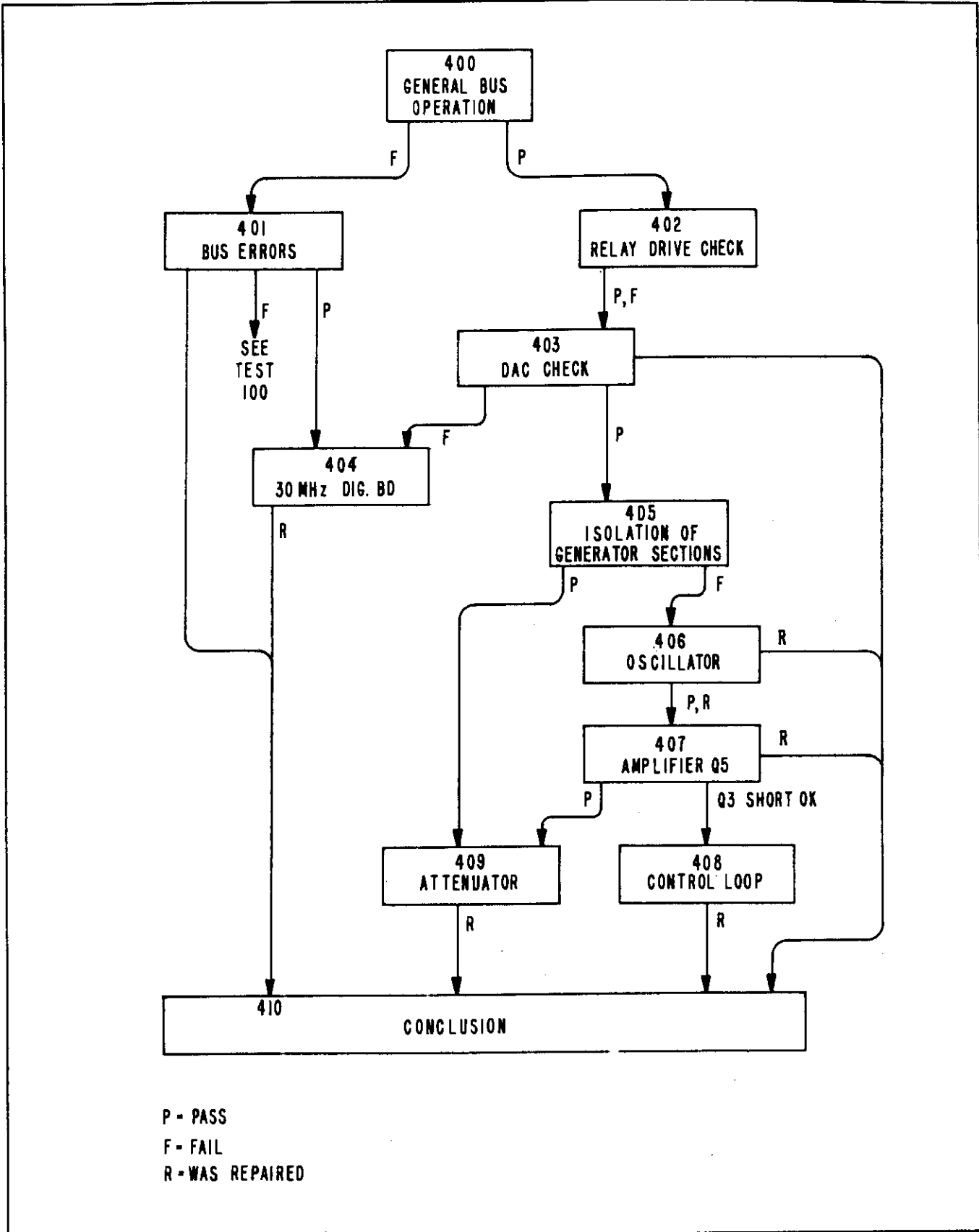

Figure 6-303. 30 MHz Calibrator Troubleshooting

2. Check U20 for a binary counting sequence on pins 14, 12, 8, 9, and 11 respectively. The frequencies encountered on these pins are 16 MHz (62.5 ns), 8 MHz (125 ns), 4 MHz (250 ns), 2 MHz (500ns) and 1 MHz (1.00  $\mu$ s) respectively.

3. Replace Y1 or U20 as necessary. If only one of the clock lines are bad, it may be due to a short.

4. If the clocks are OK and the display is out (black), proceed to TEST 103 (LED BACKLIGHT). If the display is illuminated but incorrect, (just blank squares for example) perform TEST 104 ( $\mu$ P QUICK CHECK).

#### 6-306. TEST 103 (LED BACKLIGHT).

If the display is black, the problem may be the LED Backlight for the LCD display module.

1. Remove the front panel of the instrument and look at the panel under the LCD. If there is no green light, check for 5 VDC at the backlight terminals of the display. Make sure the backlight cable is plugged in to J31 on the control board.

2. If the LED backlight is illuminated and the units still not working, proceed to TEST 104 ( $\mu$ P QUICK CHECK).

#### 6-307. TEST 104 ( $\mu$ P QUICK CHECK).

This test determines if a blank display is caused by a control board error or the display circuit.

1. Press ESCAPE and MULTI and set the range on 6. Monitor TP13 of any input module on the scope and put a medium signal into a sensor (or connect the 250 DC Range Calibrator and set it on range 3). Now set the range to 0; if the signal changed the microprocessor is OK and the display circuits are at fault. Do TEST 105 (DISPLAY CIRCUITS).

2. If there is no change, the microprocessor or other circuits are at fault; do a hard restart with the bit switches and retry; then do TEST 106 ( $\mu$ P DEBUG).

#### 6-308. TEST 105 (DISPLAY CIRCUITS).

Refer to the appropriate paragraph below depending on the display condition.

1. **Display Black.** An inoperative -5 V supply for viewing angle control would cause the LCD to appear black. Measure -5 V at U29 pin 2 (the junction of C25 and R27.) Check for variable voltage at pin 2 of J6 connector by rotating potentiometer R27.

2. **Display White (No characters).** A display lit and showing boxes indicates that the display unit has been reset

at power-up but that it is not getting proper control signals from the  $\mu$ P. If the  $\mu$ P checked out OK (TEST 104), the display unit itself or the interface circuitry is suspect. Check for the following:

a. U15 failure: the display must be selected by the  $\mu$ P to operate. Check for chip-select activity at U15 pin 11. If there is no CS-, see TEST 106 ( $\mu$ P).

b. U33 failure: a string of inverting buffers is used to impart a delay to the CS-. Check for CS activity at pin 12 of J6.

c. U24 failure: the data bus is buffered from the display. The lack of data transfer will cause boxes on the display. Check CS- activity. Check for data transfer through buffers by comparing input with output pins. Replace the buffers as required.

d. LCD defective: replace the LCD unit.

#### 6-309. TEST 106 (MICROPROCESSOR DEBUG).

The microprocessor ( $\mu$ P), is probably the most difficult circuit to troubleshoot. Many of the signals associated with the  $\mu$ P, such as the data and address signals, are dependent upon asynchronous external stimulation or software routines which vary with application. The  $\mu$ P encompasses circuits including: ROM, RAM, Clock, and Timing. Failure of any of which may cause catastrophic failure. Check for the following conditions and refer to the appropriate section.

1. There should be continual activity on AS- (pin 28 of the  $\mu$ P). If not, be sure that HALT- and RESET are high (RESET is driven by U23; HALT is driven low by either U23 or the  $\mu$ P). Replace the  $\mu$ P as necessary.

2. The signal AS- transition to logic low should be followed by a logic low on the DTACK- input at TP2. A transition to logic low at pin 28 followed by a low transition at TP2 is an indication that the  $\mu$ P is executing memory or I/O instructions. If AS- has activity but DTACK- does not, check for activity on U11 pins 8 and 9. If none, replace U11. Also, check U8 pins 6 and 8, and replace it if there is no activity. Proceed to TEST 107 (RAM) if the unit is still not working.

#### 6-310. TEST 107 (NONVOLATILE RAM).

A RAM circuit failure is indicated by loss of calibration constants or the MEMORY FAIL message, or catastrophic malfunction of the  $\mu$ P. That is, a severe memory failure could lock up the  $\mu$ P so that the memory test itself could not be executed. A MEMORY FAIL display indicates that test data written to the RAM has not been read correctly and that the RAM chip may be at fault. If the 4300 gives a battery error or memory fail on power-up, perform the following tests:

1. With the instrument power off, check battery voltage. In the event that there is valid data in RAM, disturbing the voltage can corrupt the stored data. The voltage should

Section 6-300  
Troubleshooting

measure more than 3.0 V at CMOS memory U12 pin 28.

2. With instrument power on, voltage at U12 pin 28 should be 4.8 V  $\pm$ 0.3 V.

**6-311. TEST 108. (KEYBOARD CIRCUITS).**

**NOTE**

Press TEST, 1, ENTER to initiate the key test.

If the Boonton message appears on the display on power-up and it goes into measurement mode, yet the keyboard is unresponsive, the  $\mu$ P is most likely OK and the problem is in the keyboard circuits.

Integrated circuit U34 scans a matrix of key switches and produces a code used by the  $\mu$ P to identify that key.

1. Check for chip select activity on U34 pin 22. If there is no activity, see the appropriate pin on the  $\mu$ P.

2. Check for scanning signals RL0-RL7 and SL0-SL4. Lack of scanning signals indicates either the keyboard chip was not initialized for scanning mode due to  $\mu$ P failure, bad U34, or no clock on U34 pin 3.

3. If U34 is functional, the keyboard can be examined for scanning signals to localize the failure to the cable or sockets.

**6-312. TEST 109 (GPIB/IEEE-488 BUS).**

GPIB failure is indicated when the instrument display functions properly but the instrument will not respond to any GPIB command. Integrated circuit U32 is a specialized GPIB controller while U25 and U26 are buffers.

1. Check for  $\mu$ P related activity on U32 pins 3, 4, 5, 9, 18, and 19. If there is no activity, check the  $\mu$ P.

2. Check INT- (U32 pin 9) for logic high. The interrupt signal INT- should go logic low whenever the instrument is addressed to talk or listen by an external controller.

3. Check signals on buffer chips U25 and U26 for input versus output. The signals on the corresponding input/output pairs 2-18, 3-17, etc., should have similar timing. If not, replace defective U25 or check for data bus shorts. Check U26 in a similar fashion and replace as required.

**6-313. TEST 110 (CHOPPER CLOCKS, PHASE-LOCKED-LOOP [ PLL ]).**

If the  $\mu$ P, keyboard and display appear to be working, but the power readings are erratic or locked up, the chopper drive clocks could be at fault. The clock used by the input channels is generated in synchronization to the AC power line when the line frequency is 50 or 60 Hz. A signal at line frequency is derived by rectifying AC from the secondary of the power transformer and then converting the rectified voltage to a TTL signal. A PLL, U36 and U35 oscillate at a

frequency of 1920 Hz or 1600 Hz which is phase-locked to the line.

1. Check U37 pin 3 for a rectangular pulse with the same period as the line frequency, replace U37 or CR8 as required.

2. Pin 4 of U36 should be a square wave at line frequency. Also, pin 7 of U35 should be a square wave at 8 times the line frequency. If either of these signals is not there and the input (pin 10) is OK, replace U35. If there is still a problem, go to TEST 111 (INTERNAL BUS).

**6-314. TEST 111 (INTERNAL BUS).**

If the keyboard-initiated memory test and display test function, but the channels and the 30 MHz calibrator do not operate, the problem may be the internal bus. The bus operates as follows:

1. The bus buffers are enabled only when data is being transferred. U5a and U5b produce a chip select which enables U1, U2, and U3. A logic low should appear at pin 19 whenever CSZ80, CSCALMEM, or CSCAL8255 are logic low. Signal CSZ80 is active whenever a channel is accessed by the control. Signals CSCALMEM or CSCAL8255 are active only when the calibrator level is changed.

2. Buffer U1, U2, U3, and U4 can be checked by comparing input to output. Buffer U1 is bidirectional with WR- on pin 1 which specifies the direction of data travel. A high reads data from the bus assembly (channel) while a low writes data to the bus assembly.

3. Put the instrument in multichannel mode and look for activity on all data and address lines. Pulses that are very short and infrequent are acceptable. Also, each of the 6 chip select lines going out to the channel modules should have activity. If not, the 82C55 (U27) on the control board may be bad. Run the bit switch test; if S1 and S2 can be read, the 82C55 is probably OK; in that case, remove the channel modules and the 30 MHz calibrator, and test for activity again on all lines.

4. If some of the bus and control lines are OK now, then a channel module could be shorting out a line. Replace the buffer I/Cs on the channel as required. If some lines still show no activity, replace the appropriate buffer I/Cs (U1, U2, U3, U4) on the control board.

**6-315. TEST 112 (CHANNEL SWAPPING).**

If some of the channels work but some do not, swap two or more of them. If the problem follows the channel module, then the module is defective; see TEST 200 (Z80). If the problem is with a slot, the first step is to look for "HOLD CH n" lines (1 of 6) on the appropriate line, coming from the 82C55 (U27) on the control board. Replace U27 on the control board if it is suspected.

**6-316. TEST 113 (EMPTY FRAME CHECK).**

If the entire instrument is erratic, one of the channels or the 30 MHz calibrator may be corrupting the internal bus. Remove all the modules and do the Memory Test (press TEST, 3, ENTER). If this test runs satisfactorily, install channels and/or the calibrator one at a time until the 4300 fails, and troubleshoot that module. If the 4300 does not operate with all the modules removed, go to TEST 100.

**6-317. TEST 200 (CHANNEL TROUBLESHOOTING).**

Before attempting repairs, a quick check of the channel RAM contents can be made by resetting the module. This will clear out all the DC calibration constants and all channel parameters such as range, frequency, etc. Resetting will also load appropriate default values into the calibration variables. Therefore, when the module is reset, it will have to be DC calibrated using the 2510 DC Calibrator, or the calibration data on the shield label can be reentered.

To reset the channel, power-down the 4300 and set the channel's bit switch to:

- 1 Open
- 2 Open
- 3 Open
- 4 Open

**NOTE**

The battery error indication may be ignored during testing until the Bit switch is returned to its normal position. In general, the Bit switch is read on power up and at the end of the continuous tests, so when switching from a non-continuous test, the 4300 will have to be powered down, and then up again, twice. When powering down or up, wait 3 seconds each time.

Power-up and wait 3 seconds. A working module will indicate a battery error, indicating that the battery control byte has been reloaded. Power-down and set the switches back to their normal operating positions, see Table 6-202. Power-up and check the 4300 display for basic working operation. If it appears OK, proceed to TEST 210. If not, do TEST 201.

**6-318. TEST 201 (Z80, RAM, ROM TEST).**

The digital portions of the channel are checked with this test. Set the bit switch to the RAM test as shown in Table 6-202. This test checks the basic operation of the Z80, every byte in RAM, the PROM, decoder U6 and latch U17. Connect a scope probe to U17 pin 9, and power-up. A working module will indicate a logic 1 for 1 second each time the test runs. (It runs continuously). The test itself

takes about 1/2 second ( 1 1/2 total). Also, each bit of the latch should toggle at this 1 1/2 second rate, every other bit being complemented (for example, pin 2 starts out 1 and goes to 0 when the test passes). If this test fails, perform TEST 202. If it passes, proceed to Test 204.

**6-319. TEST 202 (Z80).**

Check for a 2 MHz clock at pin 6 of the Z80, if not trace back to the control board or look for shorts. Check pins 21 and 22 (read and write lines) of the Z80 for activity. If not, replace the Z80, RAM, or U16 IC's as required. (The buffer I/C's U7, U8, and U9 do not get checked during this test, however, a shorted input on one of these could possibly affect TEST 202. If they are suspect, this test can run without these.) Activity should be present on all data and address lines; even very short pulses are OK. If the trouble cannot be found with these checks, remove the Z80 and install test adapter Boonton P/N 042283, and reinstall the Z80. This ties up the data lines and puts the Z80 into continuous "NO-OPS", causing it to run through all addresses.

Look for square waves on all the address lines with the MSB's showing the lowest frequencies. Also, shorting pin 17 (NMI) to ground momentarily should cause pin 18 (HALT) to go low. If it does, the Z80 is running and the PROM is probably OK. If not, look for trouble in the PC board (shorts, etc.). In addition, TEST 203 may be run to further isolate the problem. Once the problem is found, proceed to TEST 204.

**6-320. TEST 203 (DECODER TEST).**

Set the Bit switch to the decoder test. A working module will show activity on all the outputs of the decoder U6.

**6-321. TEST 204 (+5 VDC REFERENCE).**

Check for 5.00 VDC  $\pm$ 10 mV at TP9; if not, remove U20. If voltages do not come up, replace U19 or Q3. Recheck and then continue with TEST 205.

**6-322. TEST 205 (RECORDER DAC TEST).**

Put the Bit switch in the chart recorder test and power up. The DAC output at the BNC should indicate a double ramp; the first one being 0 to 156 mV, and the second from 0 to 10 V. The period is a few seconds. The ramp should be linear with no discontinuances or setups other than the two retraces.

If this is not the case, check for -10 VDC at pin 19 of the DAC and track back through AR4 as necessary (TP9 should have +5 VDC on it; see TEST 204).

If these appear OK, check pins 2 and 3 of AR5. If they differ by more than .05 VDC or either one is above  $\pm$ 0.2 VDC, replace AR5. If there is still a problem, replace the DAC. Continue with TEST 206.

**6-323. TEST 206 (A/D TEST 1).**

Note: As of this writing, this test is inoperative. Proceed to the next test. When complete, this test will be run as follows:

Connect the recorder BNC to TP8, and a 1.78K 1% resistor from TP8 to ground. Set the bit switch to the A/D Test 1 position and power-up. No signal should be present at the sensor input, and the range should be set to 3 or higher. This test walks a "1" through the DAC and A/D and checks for proper rough operation. A working module will indicate a "1" on U17 pin 9 for 1 second every time the test passes (runs continuously). The test takes about 5 seconds.

If the test fails, check for 1 MHz on pin 8 of the A/D and trace back to the control board if it is not there. Check pin 3 of the A/D; it should be a nonlinear staircase from 0 to 4 V. If not, replace AR3 and or CR4. (Check TP8 for a 0.13 V staircase before doing this and perform TEST 205 if necessary.)

**6-324. TEST 207 (A/D TEST 2).**

Connect the recorder DAC BNC to TP8 through an 18.2K 1% resistor, and TP8 through an 84.5Ω 1% resistor to ground, and TP8 to TP4 through a 432Ω 1% resistor. Set the Bit switch to "2AD TEST", and power-up.

Check TP4 for -5VDC and monitor U17 pin 9. This test slides the A/D through a small portion of its range and checks the resolution. A working module will show a logic 1 on pin 9 for 1 second every time the test passes (it runs continuously). The test takes about 15 seconds. If the proper indication does not appear, and TEST 206 passed, check for shorts between data lines on the A/D, and replace the A/D if necessary. Continue with TEST 208.

**6-325. TEST 208 (CONTROL BOARD COMMUNICATION).**

Up to now in the Input Channel Tests, the 4300 mainframe has been used only for power and clocks. Tests prior to this have checked only the input channel. Set the Bit switch on the channel to the RAM test and power-up. From the 4300 keyboard, select single channel mode, range 3, and select the raw data mode (SPECIAL, 8, ENTER). The display should indicate the A/D value from the input module, and for this test it should be 5461.

Now press the FILTER key and note the default filter value that the instrument has selected. Escape and set range 0; now when the filter value is recalled, the displayed value should have increased. This test assures with reasonable

accuracy that the digital sections of the input module and the basic control a board are working. If not, do TEST 209, otherwise, go to TEST 210.

**6-326. TEST 209 (BUS CHECK).**

If the problem appears to be in the input channel to control board communication, swap the input module with another one if available, to see if the problem stays with the slot or moves with the module.

If the problem is with the slot, the chip select lines going back to the 82C55 on the control board can be checked. They are the only unique lines per module. That is, if other slots are OK then the data and address lines are OK.

If there is still a problem, look for shorts or opens on the bus board. If the problem follows the module, and other modules work, replace the buffers U7, U8, U9 on the channel one at a time. If more than one module is not working, the problem is probably on the control board. When the bus appears to be working, go to TEST 210.

**6-327. TEST 210 (OP AMPS AND RANGING).**

This test gives a good overall indication that most sections of the channel are functioning and gives a clue to where the problem lies, if there is one. Zero the instrument and via the keyboard, verify that the channel is in autorange mode (incidentally, resetting the module puts it in autorange). With the Boonton Model 2510 DC Range Calibrator connected to the sensor input, monitor TP13 with the scope. There should be square waves at 240 Hz or 200 Hz on each range at amplitudes shown in Table 6-301.

**TABLE 6-301. INPUT CHANNEL VOLTAGES**

| Range | TP1         | TP2         | TP13       |
|-------|-------------|-------------|------------|
| 0     | 6.52 mV p-p | 1.077 V p-p | 1.01 V p-p |
| 1     | 65.2        | 4.30        | 4.00       |
| 2     | 130         | 8.60        | 8.00       |
| 3     | 130         | 8.60        | 8.00       |
| 4     | 130         | 8.60        | 8.00       |
| 5     | 1.30 V p-p  | 8.60        | 8.00       |
| 6B    | 6.48        | 6.48        | 6.06       |

Up-ranging should be smooth and automatic, and should go from range 0 to 6 or vice versa (to range 3 for the 4312) in 150 milliseconds or less.

If the 2510 is not available, run the test using a sensor and an RF source. While voltage measurements cannot be taken, the ranging operation can be checked. However, the range overlap can be tested (if the source can be incremented in

small steps) and it should be about 0.8 dB. Ranging points are sensor dependent and do not fall on even multiples or 10 dB.

Enough information can be gathered from this test to verify operation without using the 2510 calibrator.

If the ranging appears to be OK, proceed to the dynamic filter check as shown in TEST 211.

If the module does not operate correctly, refer to the conditions specified below, and then refer to the indicated paragraph/test for diagnosis.

| For condition at TP13                        | Perform Test |
|----------------------------------------------|--------------|
| No square wave; just noise on bottom ranges: | 212          |
| Top ranges OK; 0 and 1 have high signals:    | 213          |
| +5V to -14V square wave on most ranges:      | 214          |
| Range 6 OK; some ranges not OK:              | 221          |

#### 6-328. TEST 211 (DYNAMIC FILTER CHECK).

Put the channel on range 0 and set the 2510 on range 0 (alternatively, put a small signal into the sensor). Monitor TP13 on the scope, synchronizing on TP14. There will be a lot of noise present. The signal should be a square wave at 240 Hz at 8V p-p or so (200 Hz on a 50 Hz line). The beginning 1/8 of each half cycle will have more noise than the rest of the waveform, because at the 1/8 point, the capacitors C16 and C17 are switched in. The 3 chopper pots may need adjusting, see the Adjustments section.

#### 6-329. TEST 212 (CHOPPER DRIVE TEST).

Check for chopper drive signals at pins 10 and 11 of U12. There should be square waves at 240 Hz,  $\pm 5V$ . If they seem OK, go to TEST 215.

If there is no chopper drive, trace back through Q2 which should have the same waveform on its collector. Replace U12 or Q2 as required. If Q2 has no drive (TTL 240 Hz), look for 1920 Hz and 480 Hz at U18 (TTL levels, square waves, trace back to control board if not there). At a 50 Hz line these frequencies are all reduced by 5/6.

Finally, check for regulated  $\pm 5V$  at TP3 and TP4. If less than 5V, remove the chopper and see if the voltage comes up; if it does, the chopper is defective. If the voltages are still low, replace U15 or U16 as appropriate.

These procedures should restore the chopper drive. If the chopper drive now appears OK, re-perform Test 210 and TEST 211.

#### 6-330. TEST 213 (CHOPPER COARSE ADJUST).

Put the channel on the extender card. Lift a screw on the 4300 chassis and connect a short wire between it and a similar ground screw on the channel, near the chopper. Put the channel on range 0 with no signal input. Monitor TP2 and adjust the two chopper pots for a minimum signal. Now adjust the tilt pot near the chopper. Re-perform TEST 210.

If these adjustments do not fix the problem, and the upper ranges seem OK, then the chopper is probably defective; in that case, go to TEST 220, or try swapping choppers with a known good channel.

#### 6-331. TEST 214 (LATCH).

If the TEST 210 shows a gross overload on most ranges, reset the module with the bit switch (see Table 6-202). If this fixes it, go to TEST 210.

If there is still a problem, check the latch outputs U17 according to the table listed in the Theory of Operation section on each range.

Finally, check the amplifiers as shown in TEST 215.

#### 6-332. TEST 215 (AMPLIFIER MIDPOINT, TP2).

With the channel on range 6, and the 250 on range 6B, monitor TP2 on the scope. (Alternatively, use a sensor and apply an RF signal near the top of the sensor range.)

The voltage at TP2 should be 240 Hz, 6.48 V p-p centered around 0 V. Also, check other ranges according to voltages listed in Table 6-301. If they are good, then the amplifiers are OK; proceed to TEST 216.

If there is a problem, go to TEST 217.

#### 6-333. TEST 216 (FILTER COARSE CHECK).

With the condition as set up in TEST 215, look for a 2.5 V p-p signal at TP8. If it is not there and TP2 does have a signal, Check for proper waveforms at U13 pins 9 and 10 according to the waveforms on the Input Schematic.

If they are OK, then replace U13 (while U13 is out, it may be good to check to see if the signal comes up; if it does, then U13 is not the problem - look for shorts etc.).

If the waveforms at pins 9 and 10 are not OK, trace back to U18 and replace U11 as necessary.

Finally, check TP13 for 8 V p-p or so and check the AR3 circuits as required. When operation seems normal, re-perform TEST 210 and TEST 211.

**6-334. TEST 217 (TP1-AMPLIFIER DEBUG).**  
With the condition as noted in TEST 215 monitor TP1. There should be 6.48 V p-p centered around 0 V. If there is, AR6-B or U14 are suspect; do TEST 218. If TP1 is not OK, then do TEST 219, otherwise do TEST 218.

**6-335. TEST 218 (AR6-B CIRCUITS).**  
Before replacing AR6 or U14, a simple test can be performed that should isolate the problem. With the instrument on range 6 and the 2510 on range 6B (or the sensor connected with a power near the top of its range), short pins 8 and 9 of U14. If TP2 now looks normal, replace U14, and if that does not fix it, check the resistor strings. If TP2 did not change, then replace AR6.

Finally, it may be necessary to check the latch outputs (U17) according to the table listed in the Theory of Operation section of this manual. See also TEST 221 for voltages that should be present at TP1 and TP2.

If this fixed the problem, repeat TEST 210. If the DC voltages are normal (0V) but there is no signal, do TEST 220.

**6-336. TEST 219 (AR1, 2, 6 CIRCUITS).**  
Before replacing U10, AR1, AR2, or AR6, a test can be run to isolate the problem. Set the instrument to range 6 with no input applied. Measure the DC voltage on AR1, AR2, and AR6-A outputs.

If AR6 is not 0 V and the other two are, replace AR6. If AR1 or AR2 are not OK, unplug the chopper. If this corrects the voltages, the chopper is at fault; see TEST 220.

If all three voltages are zero, the following AC test will have to be done:

Set the channel to range 6 and set the 2510 to range 6B (or use the sensor at the top of its range and look for approximate voltages). Look at pins 1 and 3 of the chopper. There should be 4.5 V p-p at 240 Hz on each pin. If not, do TEST 200. If 1 and 3 are OK, look at the outputs of AR1 and AR2. They should also have 4.5 V p-p on them. If not, short pins 4 with 8 of U10, and also pins 9 and 13. If this restores the proper AC signals, then U10 is at fault. Otherwise, it is AR1 or AR2; these are specially selected devices and must be ordered from the factory, however, stock LF356's may be substituted for checking purposes.

If these things do not remedy the problem, check the resistor strings, and finally check the latch output (U17) for conformance to the digital signals specified in the table in the Theory of Operations section.

If the proper operation is restored, repeat TEST 210; if the DC voltages look OK (0 V) but there is no signal, perform TEST 220.

**6-337. TEST 220 (CHOPPER).**  
If the chopper is suspected of having a problem, this test may be performed. Unplug the chopper, leaving the red and black wires attached. Jump pin 8 on the chopper socket to pin 3 through a 100K 5% resistor. Power-up and put the channel on range 6. Note where the tilt pot is set to and monitor TP2 on the scope.

When the tilt pot is set to either extreme, TP2 should have roughly 200 mV p-p at 240 Hz on it. At the center of the pot rotation there should be close to 0V. If these measurements are OK and the input module does not work with the chopper installed, then the chopper is defective. Replace either the chopper I/C (special Boonton P/N, but a stock CD4016 may be used for debugging) or the chopper assembly. When the chopper is working, repeat TEST 210.

**6-338. TEST 221 (ANALOG SWITCHES).**  
If TEST 210 shows a problem only on some ranges, the problem is probably U10 or U14. Check TP1 and TP2 for the voltage in Table 6-301.

If TP1 is OK and TP2 is not, replace U14, otherwise replace U10. Then repeat TEST 210.

**3-339. 30 MHz TROUBLESHOOTING.**  
The 30 MHz calibrator consists of the 30 MHz Digital Board (located on the extreme right-hand side of the instrument) and the 30 MHz Generator (the shielded assembly). The 30 MHz generator assembly must be removed from the 4300 chassis with the ribbon cable still attached, for troubleshooting. The digital board may be put on the extender card if necessary. The generator assembly should be grounded to the chassis by lifting screws on both units and attaching a wire between them.

The steps below will isolate the trouble to the particular assembly (the Generator assembly or the 30 MHz digital assembly) and to the portion of circuitry that is the most probable cause of the fault. Refer to the Troubleshooting chart at the beginning of the section.



SOME OF THE TESTS OUTLINED BELOW RESULT IN POWER LEVELS AT THE CALIBRATOR OUTPUT OF UP TO 23 dBm; BE SURE THAT THE SENSOR USED HAS AN OVERLOAD RATING ABOVE THIS VALUE.

**6-340. TEST 400 (GENERAL BUS OPERATION).**

As an assurance that the trouble is in the calibrator and not on the control board, perform the following test. Turn off power and turn it back on. Wait a few seconds for the unit to initialize and go to single channel mode and select any channel that is installed. The display should indicate a power level, the channel number, the range, etc. With no signal applied to the sensor or with no sensor connected, press SET RANGE 6, ENTER. Verify that the display shows range 6 and HOLD. If it does, proceed to TEST 402. If it does not, do TEST 401.

**6-341. TEST 401 (BUS ERRORS).**

Bus errors may show up as a "NO CALIBRATOR" message, "MEMORY ERROR" message, or the entire instrument not functioning. To test for shorted bus I/Cs, turn off the instrument and remove the 30 MHz Digital board. Power up and retest channel 1 (or any channel) as in Test 400 for basic operation. If the channel now works, replace U4 or U5 on the 30 MHz Digital board, and retest. If the channel does not work with the 30 MHz Digital board, refer to the overall 4300 troubleshooting section, TEST 100.

**6-342. TEST 402 (RELAY DRIVE).**

Press the following keys (note: the calibrator output will go to 20 dBm; disconnect the sensor from the calibrator if it is not rated for that power). SHIFT, HI LIM, 20, ENTER, CAL LEVEL, 20, ENTER. Check the voltage of the feedthrough capacitors C1, C2, and C3 on the generator assembly for the conditions shown in Table 6-302 under the 20 dBm heading. Logic highs should be above 3 volts and logic lows should be below 0.4 volts. Similarly, check the voltages at other calibrator levels as shown in the table. If any of them are incorrect, trace the signals back to the 30 MHz digital board using the schematics and replace the ribbon cable if required. Also, check the power supplies and ground at the generator and replace the ribbon cable if required. If the voltages are still incorrect, the problem is on the digital board; do TEST 403 and then TEST 404. If the voltages at the feedthrough capacitors appear OK, the digital board is partially OK, but the DAC has to be tested as shown in TEST 403.

**TABLE 6-302.  
30 MHz CALIBRATOR ATTENUATORS**

| Level | C3<br>10dB | C2<br>20dB | C1<br>40dB |
|-------|------------|------------|------------|
| +20   | HI         | HI         | HI         |
| +10   | LO         | HI         | HI         |
| 0     | HI         | LO         | HI         |
| -10   | LO         | LO         | HI         |
| -20   | HI         | HI         | LO         |
| -30   | LO         | HI         | LO         |
| -40   | HI         | LO         | LO         |
| -50   | LO         | LO         | LO         |
| -60   | LO         | LO         | LO         |

**6-343. TEST 403 (DAC CHECK).**

Connect a DC voltmeter to feedthrough capacitor C6 on the generator assembly. Ground the meter at a good point on the casting. Set the calibrator level to 0 dBm and note the voltage reading. Increment the calibrator output in 1 dB steps as shown in Table 6-303 and compare the readings to those in the table. The voltages at 0 dBm should be between 5.5 and 7.8 VDC. (If not, perform a calibration of the calibrator as listed in other sections of this manual and try again.) Divide each voltage reading by the reading at 0 dBm. Each additional 1 dB downward step should cause the voltage to decrease by the ratios shown in the table. For example, at -1 dBm, the voltage when divided by the voltage of 0 dBm should be 0.8913. These ratios should be accurate to 0.1%. If there is no voltage at all or if the voltages are incorrect, the digital board is at fault. Go to TEST 404. If everything appears normal, go to TEST 405.

**TABLE 6-303. 30 MHz CALIBRATOR  
CONTROL VOLTAGE**

| -dBm step | Ideal Voltage<br>Ratio | Typical Voltage<br>At C6 |
|-----------|------------------------|--------------------------|
| 0 dBm     | 1.000                  | 6.679V                   |
| -1        | 0.8913                 | 5.590                    |
| -2        | 0.7943                 | 5.303                    |
| -3        | 0.7079                 | 4.726                    |
| -4        | 0.6310                 | 4.213                    |
| -5        | 0.5623                 | 3.752                    |
| -6        | 0.5012                 | 3.344                    |
| -7        | 0.4467                 | 2.980                    |
| -8        | 0.3981                 | 2.657                    |
| -9        | 0.3548                 | 2.368                    |

**6-344. TEST 404 (30 MHz DIGITAL BOARD).**

If TEST 402 and 403 both failed, and the control board is OK, the problem is on the digital board, and most likely the 8255 on the digital board (U2). Put the digital board on the extender card if desired for testing. Replace U2 and recheck operation. If there is still a problem, replace U4 and U5 in that order. Finally, replace U3 which is the EEPROM and recalibrate the calibrator. (It is necessary to recalibrate if the EEPROM is replaced to get any output at all since the levels are stored in the software.)

If only TEST 403 failed, check the DC voltages at U6 pins 2 and 3 (op amp); if they are different by more than 10 mV, replace the op amp. If they are the same, replace the D to A converter U1. If this is done, the calibrator will have to be recalibrated. Refer to TEST 410 once the problem is found.

If TESTS 402 and 403 passed, go to TEST 405.



**6-345. TEST 405 (ISOLATION OF GENERATOR SECTIONS).**

To determine roughly what area of the generator contains the problem, perform the following test. With the calibrator terminated with 50 ohms, set the calibrator level to 0 dBm and check the AC voltage at K1 pin 8. If it differs significantly from 6.33 volts peak-to-peak (by more than 1 volt), the problem is the amplifier or the oscillator. Go to TEST 406. If it appears normal, go to the attenuator test, TEST 409.

**6-346. TEST 406 (OSCILLATOR).**

Connect a scope probe to TP1 on the generator assembly and set the level to 20 dBm via the front panel. There should be a 30 MHz signal at about 6 V peak to peak. If there is, proceed to TEST 407. If not, check for the following conditions: Note: Q1, Q2, and Q4 should operate independently from the rest of the generator. Even if there is trouble elsewhere, there should be oscillation in this circuit.

1. The collector of Q2 should be greater than 14 VDC. If not, check for a low at J46 pin 8. Check for shorts in the DC path on Q2, and hot components. Replace Q2 as necessary.
2. The emitter of Q1 should be 1 VDC  $\pm$  0.5 V. Replace Q1 and suspected passive components as required. Replace the crystal as required.
3. The emitter of Q4 should be from 6 to 10 VDC and oscillating at 3.5 to 5.8 V peak to peak. Replace Q4 as required.

Once oscillation has been verified, proceed to TEST 407.

**6-347. TEST (AMPLIFIER Q5).**

Set the calibrator level to 0 dBm. Check TP2 using the scope. There should be from 16 to 24 volts peak-to-peak at 30 MHz. If there is, proceed to TEST 409. If the voltage is low, short the emitter to the collector of Q3 and try again. If this brings the voltage up, the problem is in the control loop; go to TEST 408. If the voltage is still too low, replace Q5. Also, replace suspected passive components that follow Q5 (C14, etc.). With Q3 still shorted, adjust C12 for a maximum level at K1 pin 8. Once the problem is found and repaired, go to TEST 410.

**6-348. TEST 408 (CONTROL LOOP).**

The control loop consists of U1, CR2, CR3, Q3, and associated components. The circuit compares the DC voltage at the anode of CR2 to the AC voltage at the anode of CR3. U1 then applies the proper DC voltage to the Q5 amplifier (through Q3) to maintain the balance. If the oscillator or

amplifier are not functioning, the voltage at U1 pin 6 will be high, in an effort to bring up the output. Similarly, if Q3 were shorted, the full DC voltage would be applied to the amplifier and the feedback loop would try to compensate by forcing U1 pin 6 to near ground.

First check the op amp by measuring the DC voltages at pins 2, 3, and 6 of U1. The op amp is suspect if any of the conditions below are present:

1. Pin 2 is higher than pin 3 by more than 10 mV and pin 6 is greater than 2 VDC, or,
2. Pin 2 is less than pin 3 by more than 10 mV and pin 6 is less than 12 VDC. (It may be necessary to remove Q3 and CR1 for this test if the voltage appears to be shorted to ground.)

Check to see that the DC voltage at pin 2 of the op amp is roughly equal to the peak voltage at the CR3 anode, and that the voltage at pin 3 of the op amp is about 0.5 V lower than that of the CR2 anode. If not, replace the diodes as required. Also, replace Q3 as required. Once the control loop has been repaired, proceed to TEST 410.

**6-349. TEST 409 (ATTENUATOR).**

The attenuator consists of 3 sections having switched attenuations of 10, 20, and 40 dB. Precision resistors are used primarily for stability. Errors in resistance values of several percent can be tolerated because errors are compensated for in software. Most attenuator faults will occur with the switch driver transistors and with the relays.

**TABLE 6-304.  
30 MHz CALIBRATOR RF VOLTAGES**

| Level in dBm | Output at N Connector Terminated (volts peak-to-peak) |
|--------------|-------------------------------------------------------|
| 20 dBm       | 6.30 V p-p                                            |
| 10           | 2.00 V p-p                                            |
| 0            | 630 mV p-p                                            |
| -10          | 200 mV p-p                                            |
| -20          | 63 mV p-p                                             |
| -30          | 20 mV p-p                                             |
| -40          | 6.3 mV p-p                                            |
| -50          | 2.0 mV p-p                                            |

Check Q6 through Q8 by setting the calibrator level in 10 dB increments as shown in Table 6-302. When the base drives are low, the transistors should be on and their collectors should be from 3.2 to 4.2 VDC. Otherwise they should be 0 VDC. Replace the transistors as required. The switching of the relays should be audible. If there is relay drive but no "clicking", the relay is probably at fault. If a particular section is suspected, it can be cycled by changing the output level by that amount. For example, changing from 20 dBm to

0 dBm will cycle the 20 dB pad. Refer to Table 6-302 to see which relays switch for various level changes. Also see Table 6-304 for the RF voltages for various levels. If the relays all "click" and there is still a problem, and the contacts are probably bad. Replace the relays as required. Finally, replace the precision resistors as required. Proceed to TEST 410.

#### 6-350. TEST 410 (CONCLUSION).

Reassemble the calibrator and recheck basic operation at various power levels. If repairs have been made to the analog circuits (including the D to A converter), recalibration will be necessary. Refer to the Calibration section of this manual. Repairs to the digital circuits or the relay drive circuits will not require recalibration. However, replacement of a relay requires recalibration if maximum accuracy is desired since the contact resistance can vary somewhat from unit to unit. At the manufacture time of the generator, the relays are cycled about 1000 times to "break in" the contacts. If this is desired, return the unit to the factory.

#### 6-351. TEST 300. (50 MHz CALIBRATOR TROUBLESHOOTING.)

With the 50 MHz calibrator removed from the 4300, but still connected, perform the following tests:

Terminate the output with 50 ohms and connect a scope probe between the junction of C10 and R15. The amplitude should be 1.2 V p-p, +/-0.4 V. The frequency should be  $50 \pm 0.5$  MHz. If the voltage is too high, the control loop is probably not working; AR1 is probably at fault. If there is no signal, check the emitter voltage of Q1; it should be -11 V  $\pm$  2V. If it is not within those limits, Q1 may be shorted or open.

A low signal at the C10-R15 junction may be due to a misadjustment of C4 or C12. Also, the reference voltage at U1 pin should be -10.0 V  $\pm$  .05. If it is too low or too high, U1 is at fault.

Pin 3 of AR1 should be -3 to -4 V; if not, check the reference voltage path. Pin 2 of the same op amp should be within 5 mV of pin 3; if not, check R6, R9, CR3, and CR2 for opens or shorts.

## SECTION 7 PARTS LIST

### 7-1. INTRODUCTION.

Table 7-2. Replaceable Parts, lists all the replaceable parts and includes: the reference symbol, description, Mfr., Mfr's Part No. and the BEC Part No. Table 7-1. Manufacturer's Federal Supply Code Numbers, list the manufacturer's federal supply numbers.

**TABLE 7-1. MANUFACTURER'S FEDERAL SUPPLY CODE NUMBERS**

| Number | Name                     | Number | Name                        |
|--------|--------------------------|--------|-----------------------------|
| 00241  | Fenwal Electronics       | 31313  | Components Corp.            |
| 01121  | Allen Bradley            | 31918  | ITT Schadow, Inc.           |
| 01247  | Sprague Electric Company | 32575  | AMP                         |
| 01295  | Texas Instruments        | 32897  | Erie                        |
| 02660  | Amphenol                 | 32997  | Bourns, Inc., Trimpot Div.  |
| 02735  | RCA Solid State Division | 33297  | NEC                         |
| 03888  | Pyrofilm (KDI)           | 33883  | RMC                         |
| 04713  | Motorola Semiconductor   | 34335  | Advanced Micro Devices      |
| 04901  | Boonton Electronics      | 51640  | Analog Devices, Inc.        |
| 06383  | Panduit Corp.            | 52464  | OKI                         |
| 06776  | Robinson Nugent, Inc.    | 54420  | Dage - MTI                  |
| 07263  | Fairchild Semiconductor  | 54426  | Buss Fuses                  |
| 07326  | Fairchild Semiconductor  | 54473  | Panasonic                   |
| 13812  | Dialco Div. of Amperex   | 56289  | Sprague Electric Company    |
| 14655  | Cornell-Dubilier         | 56708  | Zilog, Inc.                 |
| 17801  | Panel Corp. (Schurter)   | 57582  | Kahgan Electronics Corp.    |
| 19701  | Mepeo Electra            | 61637  | Kemet-Union Carbide         |
| 20307  | Arco - Micronics         | 71450  | CTS Corp.                   |
| 24226  | Gowanda Electronics      | 73138  | Beckman Instr. Helipot Div. |
| 27014  | National Semiconductor   | 81073  | Grayhill                    |
| 27264  | Molex, Inc.              | 91293  | Johanson                    |
| 27735  | F-Dyne Electronics       | 91506  | Augat                       |
| 27777  | Varo Semiconductor       | 98291  | Sealectro Corp.             |
| 28480  | Hewlett-Packard Corp.    | 99942  | Centralab                   |
|        |                          | S4217  | United Chemicon, Inc.       |

Section 7  
Parts List

TABLE 7-2. REPLACEABLE PARTS

| 04310101C REV: A* '4300' READY INVENTORY (GRAY)<br>MODEL: 4300 |                              |           |                          |                 |
|----------------------------------------------------------------|------------------------------|-----------|--------------------------|-----------------|
| REFERENCE DESIGNATOR                                           | DESCRIPTION                  | FED. CODE | MANUFACTURER PART NUMBER | BEC PART NUMBER |
| A4                                                             | '4300' SIDE FRAME LEFT ASSY  | 04901     | 04311200A                | 04311200A       |
| A7                                                             | PWA '4300' CONTROL           |           |                          | 04310300K       |
| A11                                                            | PWA '4300' BUS               | 04901     | 04310700A                | 04310700A       |
| A13                                                            | '4300' SUB PANEL ASSY (GRAY) |           |                          | 04311601A       |
| U6                                                             | PROM 4300 A7 U6 CONTROL      | 04901     | 53441500D                | 53441500D       |
| U18                                                            | PROM 4300 A7 U18 CONTROL     | 04901     | 53439900D                | 53439900D       |

| 04310300K REV: A* PWA '4300' CONTROL<br>MODEL: 4300 |                                |           |                          |                 |
|-----------------------------------------------------|--------------------------------|-----------|--------------------------|-----------------|
| REFERENCE DESIGNATOR                                | DESCRIPTION                    | FED. CODE | MANUFACTURER PART NUMBER | BEC PART NUMBER |
| BT1                                                 | CELL LITHIUM 3V                | 54473     | BR2325-1HB               | 556007000       |
| C1-2,4-6,                                           | CAP CER 0.1uF 20% 50V          | 04222     | SR215E104MAA             | 224268000       |
| C7                                                  | CAP TANT 15uF 10% 20V          | 56289     | 199D156X9020DA1          | 283227000       |
| C8-12,14,                                           | CAP CER 0.1uF 20% 50V          | 04222     | SR215E104MAA             | 224268000       |
| C13,25                                              | CAP EL 10uF 20% 25V            | 54217     | SM-25-VB-10-M            | 283336000       |
| C15                                                 | CAP EL 15000uF 25V             | 54473     | ECE-T25R153SW            | 28336400A       |
| C17-18                                              | CAP EL 2200uF 20% 35V          | 57582     | KSM-2200-35              | 283351000       |
| C19-21                                              | CAP EL 100uF 20% 25V           | 54217     | SM-25-VB-101M            | 283334000       |
| C22-23,                                             | CAP CER 0.1uF 20% 50V          | 04222     | SR215E104MAA             | 224268000       |
| C26-27,                                             | CAP CER 0.1uF 20% 50V          | 04222     | SR215E104MAA             | 224268000       |
| C28                                                 | CAP MPC 0.01uF 2% 50V          | 14752     | 652A-1A-103G             | 234142000       |
| C29                                                 | CAP MPC 0.1uF 2% 50V           | 14752     | 652A-1-A-104G            | 234139000       |
| C30-34                                              | CAP CER 0.1uF 20% 50V          | 04222     | SR215E104MAA             | 224268000       |
| CR1,3,8                                             | DIODE SIG 1N914                | 01295     | 1N914                    | 530058000       |
| CR2,6-7                                             | DIODE SIG 1N4001               | 04713     | 1N4001                   | 530151000       |
| CR4,9                                               | DIODE ZENER 1N6231B 5.1V 5%    | 04713     | 1N6231B                  | 530169000       |
| CR5                                                 | DIODE BRIDGE KBP02             | 15281     | KBP02                    | 532013000       |
| J28                                                 | HEADER 3 PIN STRAIGHT .156 SPA | 06383     | HPSS156-3-C              | 477343000       |
| J29,31                                              | CONN M 02 CKT ST POLZ .1CT     | 06383     | MPSS100-2-A              | 47740702A       |
| J30                                                 | SOCKET IC 14 PIN               | 06776     | ICN-143-S3-G             | 473019000       |
| J32                                                 | SOCKET IC 16 PIN               | 06776     | ICN-163-S3-G             | 473042000       |
| J34                                                 | SOCKET IC 24 PIN               | 06776     | ICN-246-S4-G             | 473043000       |
| J35                                                 | CONN M 09 CKT ST POLZ .1CT     | 06383     | HPSS100-9-C              | 477374000       |
| J36                                                 | CONN M 05 CKT ST POLZ .1CT     | 06383     | HPSS100-5-C              | 477382000       |
| Q1                                                  | TRANS NPN 2N3904               | 04713     | 2N3904                   | 528071000       |
| R1-4,30                                             | RES NETWORK 3K/6.2K 2% 2.7W    | 73138     | L105-5-R3K/6.2K          | 345031000       |
| R5,35                                               | RES MF 100K 1% 1/4W            | 19701     | 5043ED100K0F             | 341500000       |
| R6,13,                                              | RES MF 4.75K 1% 1/4W           | 19701     | 5043ED4K750F             | 341365000       |
| R7,32                                               | RES MF 147K 1% 1/4W            | 19701     | 5043ED147K0F             | 341516000       |
| R8                                                  | RES MF 3.01K 1% 1/4W           | 19701     | 5043ED3K010F             | 341346000       |
| R9                                                  | RES VAR 1K 10% 0.5W            | 73138     | 72PR1K                   | 311316000       |
| R10,17                                              | RES MF 1.00K 1% 1/4W           | 19701     | 5043ED1K000F             | 341300000       |
| R11                                                 | RES MF 47.5K 1% 1/4W           | 19701     | 5043ED47K50F             | 341465000       |
| R12                                                 | RES MF 100 OHM 1% 1/4W         | 19701     | 5043ED100R0F             | 341200000       |
| R14,16,18,                                          | RES MF 10.0K 1% 1/4W           | 19701     | 5043ED10K00F             | 341400000       |
| R15,21                                              | RES MF 2.00K 1% 1/4W           | 19701     | 5043ED2K000F             | 341329000       |
| R19-20,28,                                          | RES MF 4.75K 1% 1/4W           | 19701     | 5043ED4K750F             | 341365000       |
| R22,34,36                                           | RES MF 10.0K 1% 1/4W           | 19701     | 5043ED10K00F             | 341400000       |
| R23                                                 | RES MF 4.99K 1% 1/4W           | 19701     | 5043ED4K990F             | 341367000       |
| R24                                                 | RES MF 2.21K 1% 1/4W           | 19701     | 5043ED2K210F             | 341333000       |
| R25                                                 | RES MF 12.7K 1% 1/4W           | 19701     | 5043ED12K70F             | 341410000       |
| R26                                                 | RES NETWORK 10K 2% 1.5W        | 71450     | 750-101-R10K             | 345038000       |
| R29                                                 | RES NETWORK 100K 2% 1.5W       | 71450     | 750-61-R100K             | 345032000       |
| R31                                                 | RES MF 39.2K 1% 1/4W           | 19701     | 5043ED39K20F             | 341457000       |
| R33                                                 | RES COMP 10M 5% 1/4W           | 01121     | CB1065                   | 343700000       |

TABLE 7-2. REPLACEABLE PARTS (Cont.)

| 04310300K            |                                | REV: A* PWA '4300' CONTROL (Cont) |                          |                 |
|----------------------|--------------------------------|-----------------------------------|--------------------------|-----------------|
| MODEL: 4300          |                                |                                   |                          |                 |
| REFERENCE DESIGNATOR | DESCRIPTION                    | FED. CODE                         | MANUFACTURER PART NUMBER | BEC PART NUMBER |
| R37                  | RES MF 1.00M 1% 1/4W           | 19701                             | 5043ED1M000F             | 341600000       |
| R38-40               | RES MF 4.75K 1% 1/4W           | 19701                             | 5043ED4K750F             | 341365000       |
| S1                   | SWITCH ROCKER 8PST DIP         | 81073                             | 769B08                   | 465225000       |
| S2                   | SWITCH SLIDE SPST (4 SW)       | 71450                             | 206-4ST                  | 465219000       |
| U1,24                | IC 74LS645 TRANSCEIVER         | 01295                             | SN74LS645N               | 534382000       |
| U2-4                 | IC 74LS541 OCTAL BUFFER        | 01295                             | SN74LS541N               | 534381000       |
| U5,14                | IC 74LS08 QUAD 2 INPUT AND     | 18324                             | SN74LS08N                | 534156000       |
| U7,30                | IC 74LS138 DECDR/MPX           | 01295                             | SN74LS138N               | 534246000       |
| U8                   | IC 74LS74 FLIP FLOP            | 01295                             | SN74LS74N                | 534157000       |
| U10,12               | IC 5564 8Kx8 RAM CMOS 28 DIP   | 33297                             | UPD4464C-15L             | 534403000       |
| U11,20               | IC 74LS93 DIVIDE BY 16 COUNTER | 01295                             | SN74LS93N                | 534230000       |
| U13                  | IC 74LS02 2 INPT POS NOR       | 01295                             | SN74LS02N                | 534154000       |
| U15                  | IC 74LS32 QUAD 2 INPUT OR      | 01295                             | SN74LS32N                | 534168000       |
| U16,33               | IC 74LS04 HEX INVERTER         | 01295                             | SN74LS04N                | 534155000       |
| U17                  | IC 74HC00 QUAD 2 INPUT NAND    | 01295                             | SN74HC00N                | 53442505A       |
| U19                  | IC 68008 MICROPROCESSOR 16 BIT | 04713                             | MC68008L10               | 534402000       |
| U21,35               | IC 40408 COUNTER/DIVIDER       | 02735                             | CD40408E                 | 534275000       |
| U22                  | IC 339 QUAD COMPARATOR         | 27014                             | LM339N                   | 535018000       |
| U23                  | IC 7407 HEX BUFFER             | 01295                             | SN7407N                  | 534066000       |
| U25                  | IC 75160 IEEE BUS TRANSCEIVER  | 01295                             | SN75160BN                | 534286000       |
| U26                  | IC 75161 IEEE BUS TRANSCEIVER  | 01295                             | SN75161BN                | 534287000       |
| U27                  | IC 71055 INTERFACE             | 52464                             | MSM82C55A-5RS            | 53441100A       |
| U29                  | IC 79L05 VOLT REG              | 04713                             | MC79L05ACP               | 535090000       |
| U32                  | IC 9914ANL IEEE BUS PROCESSOR  | 01295                             | TMS9914ANL               | 534288000       |
| U34                  | IC 8279-2 KEYBD/DISP INTERFACE | 33297                             | uPD8279C-2               | 534211000       |
| U36                  | IC 40468 PHASE LOCK LOOP       | 02735                             | CD40468E                 | 53444706A       |
| U37                  | IC 40938 QUAD 2 INPUT NAND     | 02735                             | CD40938E                 | 53444714A       |
| W39                  | CABLE ASSY WIRE 22GA 2C 6.50L  | 04901                             | 571206000                | 571206000       |
| XS1                  | SOCKET IC 16 PIN ANGLED PC MT  | 51167                             | 16-810-90T               | 473075010       |
| XS2                  | SOCKET IC 8 PIN                | 06776                             | ICN-083-S3-G             | 473041000       |
| XU1-4,               | SOCKET IC 20 PIN               | 06776                             | ICN-203-S3-G             | 473065000       |
| XU5,8,11,            | SOCKET IC 14 PIN               | 06776                             | ICN-143-S3-G             | 473019000       |
| XU6,10,12,           | SOCKET IC 28 PIN               | 06776                             | ICN-286-S4-G             | 473044000       |
| XU7,21,30,           | SOCKET IC 16 PIN               | 06776                             | ICN-163-S3-G             | 473042000       |
| XU13-17,20           | SOCKET IC 14 PIN               | 06776                             | ICN-143-S3-G             | 473019000       |
| XU18                 | SOCKET IC 28 PIN               | 06776                             | ICN-286-S4-G             | 473044000       |
| XU19                 | SOCKET IC 48 PIN               | 06776                             | ICN-486-S5-G             | 473076000       |
| XU22-23,33           | SOCKET IC 14 PIN               | 06776                             | ICN-143-S3-G             | 473019000       |
| XU24-26              | SOCKET IC 20 PIN               | 06776                             | ICN-203-S3-G             | 473065000       |
| XU27,32,34           | SOCKET IC 40 PIN               | 06776                             | ICN-406-S4-TG            | 473052000       |
| XU35-36,             | SOCKET IC 16 PIN               | 06776                             | ICN-163-S3-G             | 473042000       |
| XU37                 | SOCKET IC 14 PIN               | 06776                             | ICN-143-S3-G             | 473019000       |
| Y1                   | CRYSTAL OSC 16 MHz TTL DIP     | 81654                             | 970-16.0 MHz             | 547906010       |

| 04310350B            |                             | REV: A- PWB '4300' UNIT CONTROL |                          |                 |
|----------------------|-----------------------------|---------------------------------|--------------------------|-----------------|
| MODEL: 4300          |                             |                                 |                          |                 |
| REFERENCE DESIGNATOR | DESCRIPTION                 | FED. CODE                       | MANUFACTURER PART NUMBER | BEC PART NUMBER |
| P27                  | CONNECTOR DIN 64 CKT FEMALE | 06776                           | RNE-64CRS-SR-TG30        | 479434000       |

Section 7  
Parts List

TABLE 7-2. REPLACEABLE PARTS (Cont.)

| 04310700A REV: EB PWA '4300' BUS<br>MODEL: 4300 |                             |                  |                                 |                        |
|-------------------------------------------------|-----------------------------|------------------|---------------------------------|------------------------|
| <u>REFERENCE DESIGNATOR</u>                     | <u>DESCRIPTION</u>          | <u>FED. CODE</u> | <u>MANUFACTURER PART NUMBER</u> | <u>BEC PART NUMBER</u> |
| C1                                              | CAP CER 0.1uF 20% 50V       | 04222            | SR215E104MAA                    | 224268000              |
| J19-25                                          | CONNECTOR 44 PIN            | 31781            | 305-044-521-202                 | 479254000              |
| J26,28                                          | CONN M 02 CKT ST POLZ .1CT  | 06383            | MPS8100-2-A                     | 47740702A              |
| J27                                             | CONNECTOR 64 PIN RT ANGLE   | 06776            | RNE-64CP-SR-TG30                | 477406000              |
| R1                                              | RES NETWORK 3K/6.2K 2% 2.7W | 73138            | L105-5-R3K/6.2K                 | 345031000              |

| 04310801A REV: A* PWA '4300' KEYBOARD (GRAY)<br>MODEL: 4300 |                        |                  |                                 |                        |
|-------------------------------------------------------------|------------------------|------------------|---------------------------------|------------------------|
| <u>REFERENCE DESIGNATOR</u>                                 | <u>DESCRIPTION</u>     | <u>FED. CODE</u> | <u>MANUFACTURER PART NUMBER</u> | <u>BEC PART NUMBER</u> |
| J33                                                         | SOCKET IC 16 PIN       | 06776            | ICN-163-S3-G                    | 473042000              |
| R1                                                          | RES VAR 25K 10% 0.5W   | 73138            | 72PR25K                         | 311400000              |
| S1-30                                                       | SWITCH PUSHBUTTON SPST | 31918            | 210272                          | 465230000              |

| 04311200A REV: C* '4300' SIDE FRAME LEFT ASSY<br>MODEL: 4300 |                                |                  |                                 |                        |
|--------------------------------------------------------------|--------------------------------|------------------|---------------------------------|------------------------|
| <u>REFERENCE DESIGNATOR</u>                                  | <u>DESCRIPTION</u>             | <u>FED. CODE</u> | <u>MANUFACTURER PART NUMBER</u> | <u>BEC PART NUMBER</u> |
| T1                                                           | TRANSFORMER POWER              | 04901            | 44609600B                       | 44609600B              |
| W28                                                          | CABLE ASSY WIRE 22GA 3C 22.50L | 04901            | 57121702A                       | 57121702A              |
| W37-38                                                       | CABLE ASSY WIRE 20GA 1C 24.50L | 04901            | 57121802A                       | 57121802A              |
| W48                                                          | CABLE ASSY (TRANSFORMER)       | 04901            | 57122900A                       | 57122900A              |

| 04311301D REV: A* '4300' HEAT SINK ASSY<br>MODEL: 4300 |                               |                  |                                 |                        |
|--------------------------------------------------------|-------------------------------|------------------|---------------------------------|------------------------|
| <u>REFERENCE DESIGNATOR</u>                            | <u>DESCRIPTION</u>            | <u>FED. CODE</u> | <u>MANUFACTURER PART NUMBER</u> | <u>BEC PART NUMBER</u> |
| C1-3                                                   | CAP TANT 10uF 10% 35V         | 56289            | 196D106X903PE4                  | 283353000              |
| CR1                                                    | DIODE BRIDGE 15A 50V          | 11961            | SDA-980-1                       | 532030000              |
| R1                                                     | RES COMP 4.7 OHM 5% 2W        |                  |                                 | 304998000              |
| U1                                                     | IC 323K REGULATOR             | 27014            | LM323K                          | 535024000              |
| U2                                                     | IC 79MGUIC NEG VOLT REG       | 07263            | UA79MGUIC                       | 535043000              |
| U3                                                     | IC LM78GCP VOLT REG           | 27014            | LM78GCP                         | 535055000              |
| U4                                                     | IC 350 VOLTAGE REGULATOR      |                  |                                 | 53516100A              |
| W35                                                    | CABLE ASSY 9 COND             |                  |                                 | 57121301A              |
| W36                                                    | CABLE ASSY UNIT 24GA 4C 7.00L | 04901            | 57122400A                       | 57122400A              |

TABLE 7-2. REPLACEABLE PARTS (Cont.)

| 04311400B            |                                | REV: K* '4300' REAR PANEL ASSEMBLY |                          |                 |
|----------------------|--------------------------------|------------------------------------|--------------------------|-----------------|
| MODEL: 4300          |                                |                                    |                          |                 |
| REFERENCE DESIGNATOR | DESCRIPTION                    | FED. CODE                          | MANUFACTURER PART NUMBER | BEC PART NUMBER |
| A3                   | '4300' REAR PANEL UNIT         | 04901                              | 60471600B                | 60471600B       |
| A8                   | '4300' HEAT SINK ASSY          |                                    |                          | 04311301D       |
| F1                   | FUSE 3/4A (0.75A) 250V SLO-BLO | 54426                              | MDL-3/4                  | 545533000       |
| W34                  | CABLE ASSY FLAT 24 CKT GPIB    |                                    |                          | 92021200A       |
| W47                  | CABLE ASSY (PWR SW)            | 04901                              | 57118201A                | 57118201A       |
| W48                  | CABLE ASSY REAR PANEL          | 04901                              | 57123000A                | 57123000A       |

| 04311601A            |                              | REV: A* '4300' SUB PANEL ASSY (GRAY) |                          |                 |
|----------------------|------------------------------|--------------------------------------|--------------------------|-----------------|
| MODEL: 4300          |                              |                                      |                          |                 |
| REFERENCE DESIGNATOR | DESCRIPTION                  | FED. CODE                            | MANUFACTURER PART NUMBER | BEC PART NUMBER |
| A5                   | POWER SWITCH ASSY (GRAY)     |                                      |                          | 04311705A       |
| A6                   | '4300' DISPLAY ASSY LCD/LED  |                                      |                          | 04323000B       |
| A10                  | PWA '4300' KEYBOARD (GRAY)   |                                      |                          | 04310801A       |
| A12                  | 4300 PLATE CONN ASSY (GRAY)  |                                      |                          | 04311901A       |
| R1-12                | RES CF 120 OHM 5% 1/8W       | 54473                                | ERD-10-T-J-121           | 335654000       |
| W30                  | CABLE ASSY FLAT 14CKT 11.00L | 04901                                | 57222800B                | 57222800B       |
| W32                  | CABLE ASSY FLAT 16CKT 6.00L  | 04901                                | 57222707A                | 57222707A       |

| 04311705A            |                                | REV: A* POWER SWITCH ASSY (GRAY) |                          |                 |
|----------------------|--------------------------------|----------------------------------|--------------------------|-----------------|
| MODEL: 4300          |                                |                                  |                          |                 |
| REFERENCE DESIGNATOR | DESCRIPTION                    | FED. CODE                        | MANUFACTURER PART NUMBER | BEC PART NUMBER |
| DS1                  | LED YELLOW DIFF 5082-4684      | 28480                            | HLMP-1401                | 536034000       |
| R1                   | RES MF 267 OHM 1% 1/4W         | 19701                            | 5043ED267ROF             | 341241000       |
| S1                   | SWITCH ROCKER DP/DT (GRAY)     |                                  | 46532200A                |                 |
| W29                  | CABLE ASSY WIRE 24GA 2C 10.00L | 04901                            | 57222901A                | 57222901A       |

| 04311901A            |                              | REV: A* 4300 PLATE CONN ASSY (GRAY) |                          |                 |
|----------------------|------------------------------|-------------------------------------|--------------------------|-----------------|
| MODEL: 4300          |                              |                                     |                          |                 |
| REFERENCE DESIGNATOR | DESCRIPTION                  | FED. CODE                           | MANUFACTURER PART NUMBER | BEC PART NUMBER |
| C1-12                | CAP PP 0.01uF 10% 100V       | 27736                               | PP1X-01-100-10           | 23417100A       |
| J1-6                 | (G) CONN ASSY FEMALE w/o HDW | 04901                               | 09214101C                | 09214101C       |

| 04323000B            |                               | REV: AA '4300' DISPLAY ASSY LCD/LED |                          |                 |
|----------------------|-------------------------------|-------------------------------------|--------------------------|-----------------|
| MODEL: 4300          |                               |                                     |                          |                 |
| REFERENCE DESIGNATOR | DESCRIPTION                   | FED. CODE                           | MANUFACTURER PART NUMBER | BEC PART NUMBER |
| A5(1)                | DISPLAY DOT MATRIX LCD/LED    |                                     |                          | 55500400A       |
| W31                  | CABLE ASSY WIRE 24GA 2C 5.00L | 04901                               | 57222903A                | 57222903A       |

Section 7  
Parts List

**TABLE 7-2. REPLACEABLE PARTS (Cont.)**

|                             |                                |                               |                                 |                        |
|-----------------------------|--------------------------------|-------------------------------|---------------------------------|------------------------|
| 60333201A                   |                                | REV: A* '4300' SUB PANEL UNIT |                                 |                        |
| MODEL: 4300                 |                                |                               |                                 |                        |
| <u>REFERENCE DESIGNATOR</u> | <u>DESCRIPTION</u>             | <u>FED. CODE</u>              | <u>MANUFACTURER PART NUMBER</u> | <u>BEC PART NUMBER</u> |
| J8A,8B,8C,                  | CONN F 01 CKT RED .040 DIA TFL | 71279                         | 450-4352-1-0312                 | 47944902A              |
| J8D,8E,8F                   | CONN F 01 CKT RED .040 DIA TFL | 71279                         | 450-4352-1-0312                 | 47944902A              |

|                             |                             |                                |                                 |                        |
|-----------------------------|-----------------------------|--------------------------------|---------------------------------|------------------------|
| 60471600B                   |                             | REV: CB '4300' REAR PANEL UNIT |                                 |                        |
| MODEL: 4300                 |                             |                                |                                 |                        |
| <u>REFERENCE DESIGNATOR</u> | <u>DESCRIPTION</u>          | <u>FED. CODE</u>               | <u>MANUFACTURER PART NUMBER</u> | <u>BEC PART NUMBER</u> |
| J47                         | CONNECTOR LINE CORD         | 82389                          | EAC309                          | 477281000              |
| S1                          | SWITCH DUAL SLIDE DPDT-DPDT | 82389                          | 47206LFR                        | 465279000              |



TABLE 7-2. REPLACEABLE PARTS (Cont.)

04310400E REV: D\* PWA '4300' INPUT COMMON  
MODEL: 4300

| REFERENCE DESIGNATOR | DESCRIPTION                    | FED. CODE | MANUFACTURER PART NUMBER | BEC PART NUMBER |
|----------------------|--------------------------------|-----------|--------------------------|-----------------|
| AR3-5                | IC 356P OP AMP                 | 27014     | LF356N                   | 535907000       |
| AR6                  | IC TLO72BCP DUAL OP AMP        | 01295     | TLO72BCP                 | 535102000       |
| BT1                  | CELL LITHIUM 3V                | 54473     | BR2325-1HB               | 556007000       |
| C1                   | CAP TANT 15uF 10% 20V          | 56289     | 199D156X9020DA1          | 283227000       |
| C2-7,19,             | CAP CER 0.1uF 20% 50V          | 04222     | SR215E104MAA             | 224268000       |
| C8-9                 | CAP MICA 150pF 5% 100V         | 57582     | KD5151J101               | 205009000       |
| C10-11               | CAP EL 100uF 20% 25V           | 54217     | SM-25-VB-101M            | 283334000       |
| C12-15,21            | CAP EL 10uF 20% 25V            | 54217     | SM-25-VB-10-M            | 283336000       |
| C16-17               | CAP MPC 0.1uF 2% 50V           | 14752     | 652A-1-A-104G            | 234139000       |
| C18                  | CAP MICA 430pF 1% 500V         | 14655     | CD15FD431F03             | 200037000       |
| C20                  | CAP CER 0.01uF 10% 100V        | 04222     | SR201C103KAA             | 224269000       |
| C22,24-26            | CAP CER 0.1uF 20% 50V          | 04222     | SR215E104MAA             | 224268000       |
| C23                  | CAP CER 1.0uF 20% 50V          | 04222     | SR305E105MAA             | 224264000       |
| CR1-2,4-6            | DIODE SIG 1N914                | 01295     | 1N914                    | 530058000       |
| CR3                  | DIODE HSCH1001 (1N6263)        | 28480     | HSCH-1001                | 530174000       |
| J48/1-48/8           | SOCKET SPRING COMP LEAD .072   | 32575     | 1-332070-7               | 479333000       |
| J49                  | CONN M 2 CKT ST .1CT           | 27264     | 22-10-2021               | 477361000       |
| P49                  | SHUNT 2 CIRCUIT                | 27264     | 15-38-1024               | 483253000       |
| Q1,3                 | TRANS NPN 2N3904               | 04713     | 2N3904                   | 528071000       |
| Q2                   | TRANS PNP 2N3906               | 04713     | 2N3906                   | 528076000       |
| R1,36                | RES MF 1.00K 1% 1/4W           | 19701     | 5043ED1K000F             | 341300000       |
| R2                   | RES NETWORK 100K 2% 1.5W       | 71450     | 750-61-R100K             | 345032000       |
| R3                   | RES MF 5.11K 1% 1/4W           | 19701     | 5043ED5K110F             | 341368000       |
| R4,7,42-43           | RES MF 100 OHM 1% 1/4W         | 19701     | 5043ED100R0F             | 341200000       |
| R5-6,38,50           | RES MF 4.75K 1% 1/4W           | 19701     | 5043ED4K750F             | 341365000       |
| R8-9                 | RES COMP 12M 5% 1/4W           | 01121     | CB1265                   | 343708000       |
| R10,16,              | RES MF 100K 1% 1/4W            | 19701     | 5043ED100K0F             | 341500000       |
| R11,15,              | RES MF 10.0K 1% 1/4W           | 19701     | 5043ED10K00F             | 341400000       |
| R12,14               | RES MF 887 OHM 1% 1/4W         | 19701     | 5043ED887R0F             | 341291000       |
| R13                  | RES MF 442 OHM 1% 1/4W         | 19701     | 5043ED442R0F             | 341262000       |
| R17-18               | RES MF 8.25K 1% 1/4W           | 19701     | 5043ED8K250F             | 341388000       |
| R19-20               | RES MF 6.19K 1% 1/4W           | 19701     | 5043ED6K190F             | 341376000       |
| R21                  | RES MF 3.32K 1% 1/4W           | 19701     | 5043ED3K320F             |                 |
| R22,29               | RES MF 5.62K 1% 1/4W           | 19701     | 5043ED5K620F             | 341372000       |
| R23-24,35            | RES MF 10.0K 1% 1/4W           | 19701     | 5043ED10K00F             | 341400000       |
| R25                  | RES MF 1.13M 1% 1/4W           | 19701     | 5043ED1M130F             | 341605000       |
| R26                  | RES MF 182K 1% 1/4W            | 19701     | 5043ED182K0F             | 341525000       |
| R27                  | RES MF 12.1K 1% 1/4W           | 19701     | 5043ED12K10F             | 341408000       |
| R28                  | RES MF 8.06K 1% 1/4W           | 19701     | 5043ED8K060F             | 341387000       |
| R30                  | RES MF 2.49K 1% 1/4W           | 19701     | 5043ED2K490F             | 341338000       |
| R31-32               | RES MF 100K 1% 1/4W            | 19701     | 5043ED100K0F             | 341500000       |
| R33                  | RES MF 14.0K 1% 1/4W           | 19701     | 5043ED14K00F             | 341414000       |
| R34                  | RES MF 28.7K 1% 1/4W           | 19701     | 5043ED28K70F             | 341444000       |
| R37                  | RES MF 9.09K 1% 1/4W           | 19701     | 5043ED9K090F             | 341392000       |
| R39                  | RES MF 150 OHM 1% 1/4W         | 19701     | 5043ED150R0F             | 341217000       |
| R40                  | RES MF 20.0K 1% 1/4W           | 19701     | 5043ED20K00F             | 341429000       |
| R41                  | RES MF 47.5K 1% 1/4W           | 19701     | 5043ED47K50F             | 341465000       |
| R44                  | RES COMP 1.2M 5% 1/4W          | 01121     | CB1255                   | 343608000       |
| R45,47               | RES MF 332K 1% 1/4W            | 19701     | 5043ED332K0F             | 341550000       |
| R46                  | RES VAR 25K 10% 0.5W           | 73138     | 72XWR25K                 | 311385000       |
| S1                   | SWITCH PIANO 4PST DIP          | 81073     | 76PSB-04                 | 465220000       |
| U2                   | IC Z80C CPU CMOS               | 56708     | Z84C00-04PE              | 53440900A       |
| U3                   | IC 5564 8Kx8 RAM CMOS 28 DIP   | 33297     | UPD4464C-15L             | 534403000       |
| U4,8-9               | IC 74HCT541 OCTAL BUFFER       | 01295     | 74HCT541N                | 534383000       |
| U5                   | IC 74HC00 QUAD 2 INPUT NAND    | 01295     | SN74HC00N                | 53442505A       |
| U6                   | IC PEEL PROG 4300 INPUT ENCODE |           |                          | 53470800A       |
| U7                   | IC 74LS645 TRANSCEIVER         | 01295     | SN74LS645N               | 534382000       |
| U10                  | IC 6208 4 CHAN DIF MULTPXR     | 32293     | IH6208CPE                | 534266000       |

Section 7  
Parts List

TABLE 7-2. REPLACEABLE PARTS (Cont.)

| 04310400E                   |                               | REV: D* PWA '4300' INPUT COMMON (Cont.) |                                 |                        |
|-----------------------------|-------------------------------|-----------------------------------------|---------------------------------|------------------------|
| MODEL: 4300                 |                               |                                         |                                 |                        |
| <u>REFERENCE DESIGNATOR</u> | <u>DESCRIPTION</u>            | <u>FED. CODE</u>                        | <u>MANUFACTURER PART NUMBER</u> | <u>BEC PART NUMBER</u> |
| U11                         | IC 4001B QUAD 2 INPUT NOR     | 02735                                   | CD4001BE                        | 53444721A              |
| U12                         | IC 4030B QUAD EXCLUSIVE OR    | 02735                                   | CD4030BE                        | 53444722A              |
| U13                         | IC 4053B TRPL DECDR/DEMULTPXR | 04713                                   | MC14053BCP                      | 534207000              |
| U14                         | IC 6108 CMOS CHAN MULTPXR     | 32293                                   | IH6108CPE                       | 534265000              |
| U15                         | IC 78L05 VOLT REG             | 07263                                   | UA78L05AWC                      | 535044000              |
| U16                         | IC 79L05 VOLT REG             | 04713                                   | MC79L05ACP                      | 535090000              |
| U17                         | IC 74HCT373 OCTAL LATCH       | 01295                                   | SN74HCT373N                     | 53444209A              |
| U18                         | IC 4013B DUAL FLIP FLOP       | 02735                                   | CD4013BE                        | 534205000              |
| U19                         | IC MX584JH VOLTAGE REGULATOR  | 51640                                   | AD584JH                         | 535123000              |
| U20                         | IC 1206 12 BIT ADC 24 PIN DIP | 27014                                   | ADC1206BCJ-1                    | 53442001A              |
| U21                         | IC AD7548 12 BIT DAC CMOS     | 51640                                   | AD7548                          | 53512000A              |
| XU1,3                       | SOCKET IC 28 PIN              | 06776                                   | ICN-286-S4-G                    | 473044000              |
| XU2                         | SOCKET IC 40 PIN              | 06776                                   | ICN-406-S4-TG                   | 473062000              |
| XU4,6-9,17                  | SOCKET IC 20 PIN              | 06776                                   | ICN-203-S3-G                    | 473065000              |
| XU5,11-12,                  | SOCKET IC 14 PIN              | 06776                                   | ICN-143-S3-G                    | 473019000              |
| XU10,13-14                  | SOCKET IC 16 PIN              | 06776                                   | ICN-163-S3-G                    | 473042000              |
| XU18                        | SOCKET IC 14 PIN              | 06776                                   | ICN-143-S3-G                    | 473019000              |
| XU19                        | SOCKET IC 8 PIN               | 06776                                   | ICN-083-S3-G                    | 473041000              |
| XU20                        | SOCKET IC 24 PIN              | 06776                                   | ICN-246-S4-G                    | 473043000              |
| XU21                        | SOCKET IC 20 PIN              | 06776                                   | ICN-203-S3-G                    | 473065000              |
| XAR1-6,                     | SOCKET IC 8 PIN               | 06776                                   | ICN-083-S3-G                    | 473041000              |

| 043111000                   |                              | REV: AA BRACKET INPUT ASSY |                                 |                        |
|-----------------------------|------------------------------|----------------------------|---------------------------------|------------------------|
| MODEL: 4311,12,13           |                              |                            |                                 |                        |
| <u>REFERENCE DESIGNATOR</u> | <u>DESCRIPTION</u>           | <u>FED. CODE</u>           | <u>MANUFACTURER PART NUMBER</u> | <u>BEC PART NUMBER</u> |
| J9                          | (G) CONN ASSY FEMALE w/o HDW | 04901                      | 09214101C                       | 09214101C              |
| J10                         | CONN F COAX BNC              | 54420                      | UG-626B/U                       | 479123000              |

| 04324000A                   |                             | REV: BA CHOPPER MODULE ASSEMBLY '4300' |                                 |                        |
|-----------------------------|-----------------------------|----------------------------------------|---------------------------------|------------------------|
| MODEL: 4300                 |                             |                                        |                                 |                        |
| <u>REFERENCE DESIGNATOR</u> | <u>DESCRIPTION</u>          | <u>FED. CODE</u>                       | <u>MANUFACTURER PART NUMBER</u> | <u>BEC PART NUMBER</u> |
| A1                          | PWA '4300' CHOPPER SIDE ADJ |                                        |                                 | 04324100A              |

TABLE 7-2. REPLACEABLE PARTS (Cont.)

| 04324100A      REV: CA PWA '4300' CHOPPER SIDE ADJ<br>MODEL: 4300 |                                |                  |                                 |                        |
|-------------------------------------------------------------------|--------------------------------|------------------|---------------------------------|------------------------|
| <u>REFERENCE DESIGNATOR</u>                                       | <u>DESCRIPTION</u>             | <u>FED. CODE</u> | <u>MANUFACTURER PART NUMBER</u> | <u>BEC PART NUMBER</u> |
| C1-2                                                              | CAP PP 0.01uF 10% 100V         | 27735            | PP1X.01-100-10                  | 23417100A              |
| C3                                                                | CAP MICA 8.0pF 10% 300V        | 57582            | KD5080D301                      | 205001000              |
| J50-51                                                            | CONNECTOR PIN                  | 71279            | 460-1521-02-03-00               | 477400000              |
| P48                                                               | TERMINAL .040 OD .270 LG .062M | 98291            | 229-1071-000-230                | 510038000              |
| R1                                                                | RES VAR 25K 10% 0.5W           | 73138            | 72XWR25K                        | 311385000              |
| R2                                                                | RES VAR 25K 10% 0.5W           | 73138            | 72PR25K                         | 311400000              |
| R3-4                                                              | RES MF 51.1K 1% 1/4W           | 19701            | 5043ED51K10F                    | 341468000              |
| U1                                                                | (G) IC SELECTED QUAD SWITCH    | 04901            | 534223000                       | 534223000              |
| XU1                                                               | SOCKET IC 14 PIN               | 91506            | 714AG1D                         | 473056000              |

| 04310602A      REV: JD PWA '4300' CHOPPER #2<br>MODEL: 4300 |                                |                  |                                 |                        |
|-------------------------------------------------------------|--------------------------------|------------------|---------------------------------|------------------------|
| <u>REFERENCE DESIGNATOR</u>                                 | <u>DESCRIPTION</u>             | <u>FED. CODE</u> | <u>MANUFACTURER PART NUMBER</u> | <u>BEC PART NUMBER</u> |
| C1-2                                                        | CAP PP 0.01uF 10% 100V         | 27735            | PP1X.01-100-10                  | 23417100A              |
| C3                                                          | CAP MICA 8.0pF 10% 300V        | 57582            | KD5080D301                      | 205001000              |
| J50-51                                                      | CONNECTOR PIN                  | 71279            | 460-1521-02-03-00               | 477400000              |
| P48                                                         | TERMINAL .040 OD .270 LG .062M | 98291            | 229-1071-000-230                | 510038000              |
| R1-2                                                        | RES VAR 25K 10% 0.5W           | 73138            | 72PR25K                         | 311400000              |
| R3-4                                                        | RES MF 51.1K 1% 1/4W           | 19701            | 5043ED51K10F                    | 341468000              |
| U1                                                          | (G) IC SELECTED QUAD SWITCH    | 04901            | 534223000                       | 534223000              |
| XU1                                                         | SOCKET IC 14 PIN               | 91506            | 714AG1D                         | 473056000              |

| 04312202A      REV: 8* CHOPPER #2 ASSEMBLY<br>MODEL: 4300 |                       |                  |                                 |                        |
|-----------------------------------------------------------|-----------------------|------------------|---------------------------------|------------------------|
| <u>REFERENCE DESIGNATOR</u>                               | <u>DESCRIPTION</u>    | <u>FED. CODE</u> | <u>MANUFACTURER PART NUMBER</u> | <u>BEC PART NUMBER</u> |
| A1                                                        | PWA '4300' CHOPPER #2 | 04901            | 04310602A                       | 04310602A              |

Section 7  
Parts List

TABLE 7-2. REPLACEABLE PARTS (Cont.)

04312700F REV: HH PWA '4300' 30 MHz OSCILLATOR  
MODEL: 4321/4322

| REFERENCE DESIGNATOR | DESCRIPTION                    | FED. CODE | MANUFACTURER PART NUMBER | BEC PART NUMBER |
|----------------------|--------------------------------|-----------|--------------------------|-----------------|
| C1                   | CAP EL 10uF 20% 25V            | 94217     | 9M-25-VB-10-M            | 283336000       |
| C2-4,6-9             | CAP CER 0.1uF 20% 50V          | 04222     | SR215E104MAA             | 224268000       |
| C5                   | CAP MICA 120pF 5% 100V         | 14655     | CD5FA121J                | 205022000       |
| C10                  | CAP CER 0.01uF 10% 100V        | 04222     | SR201C103KAA             | 224269000       |
| C11                  | CAP MICA 10pF 5% 300V          | 14655     | CD5CC100J                | 205002000       |
| C12                  | CAP VAR 6-55pF 250V GRN        | 91293     | 9305                     | 281009000       |
| C13,19               | CAP CER 0.1uF 20% 50V          | 04222     | SR215E104MAA             | 224268000       |
| C14                  | CAP MICA 51pF 5% 300V          | 57582     | KD5510J301               | 205020000       |
| C15                  | CAP MICA 390pF 5% 50V          | 14655     | CD5FY391J                | 205028000       |
| C16,18               | CAP MICA 15pF 5% 300V          | 14655     | CD5CC150J                | 205035000       |
| C17                  | CAP MICA 91pF 1% 300V          | 14655     | CD5FC910F                | 205033000       |
| C20                  | CAP MICA 330pF 5% 50V          | 14655     | CD5FY331J                | 205029000       |
| C21-24               | CAP CER 0.1uF 20% 50V          | 04222     | SR215E104MAA             | 224268000       |
| C25                  | CAP MICA 2.0pF +-0.6pF 300V    | 57582     | KD05020D301              | 205054000       |
| C26,28               | CAP CER 0.1uF 20% 50V          | 04222     | SR215E104MAA             | 224268000       |
| C27                  | CAP CER 0.001uF 10% 100V       | 04222     | SR151C102KAA             | 224270000       |
| CR1,4-6,8            | DIODE SIG 1N914                | 01295     | 1N914                    | 530058000       |
| CR2-3                | DIODE PAIR SIG 5082-2804       |           |                          | 53019100A       |
| J46                  | CONN M 09 CKT RT ANGL PLZ .1CT | 06383     | MPAS100-9-A              | 47740909A       |
| K1-3                 | RELAY 2 FORM C (DPDT)          |           |                          | 47106300A       |
| L1,4                 | INDUCTOR 5.6uH 10%             | 24226     | 15/561                   | 400308000       |
| L2                   | INDUCTOR 0.27uH 10%            | 24226     | 10/270                   | 400250000       |
| L3                   | INDUCTOR 15uH 10%              | 24226     | 10M152K                  | 400373000       |
| L5-6                 | INDUCTOR 2.2uH 10%             | 24226     | 10/221                   | 400389000       |
| L7-8                 | INDUCTOR 0.47uH 10%            | 24226     | 10/470                   | 400368000       |
| L9                   | INDUCTOR 0.1uH 10%             | 59474     | 4416-1K                  | 400299000       |
| Q1,4                 | TRANS NPN 2N3904               | 04713     | 2N3904                   | 528071000       |
| Q2,6-8               | TRANS PNP 2N5194               | 04713     | 2N5194                   | 528137000       |
| Q3                   | TRANS NPN 2N5191               | 04713     | 2N5191                   | 528136000       |
| Q5                   | TRANS NPN 2N3866               | 04713     | 2N3866                   | 528116000       |
| R1                   | RES MF 47.5K 1% 1/4W           | 19701     | 5043ED47K50F             | 341465000       |
| R2                   | RES MF 150 OHM 1% 1/4W         | 19701     | 5043ED150R0F             | 341217000       |
| R3,5,7,48            | RES MF 100 OHM 1% 1/4W         | 19701     | 5043ED100R0F             | 341200000       |
| R4,14-15,            | RES MF 10.0K 1% 1/4W           | 19701     | 5043ED10K00F             | 341400000       |
| R6                   | RES MF 681 OHM 1% 1/4W         | 19701     | 5043ED681R0F             | 341280000       |
| R8                   | RES MF 49.9 OHM 1% 1/4W        | 19701     | 5043ED49R90F             | 341167000       |
| R9                   | RES MF 221 OHM 1% 1/4W         | 19701     | 5043ED221R0F             | 341233000       |
| R10,24,31,           | RES MF 1.00K 1% 1/4W           | 19701     | 5043ED1K000F             | 341300000       |
| R11                  | RES VAR 1M 10% 0.5W            | 73138     | 72XWR1M                  | 31142300A       |
| R12-13               | RES MF 499K 1% 1/4W            | 19701     | 5043ED499K0F             | 341567000       |
| R16                  | RES COMP 12M 5% 1/4W           | 01121     | CB1265                   | 343708000       |
| R17                  | RES MF 75.0K 1% 1/4W           | 19701     | 5043ED75K00F             | 341484000       |
| R18                  | RES MF 1.21K 1% 1/4W           | 19701     | 5043ED1K210F             | 341308000       |
| R19-22               | RES MF 200 OHM 1% 1/4W         | 19701     | 5043ED200R0F             | 341229000       |
| R23,30,37            | RES MF 10.0K 1% 1/4W           | 19701     | 5043ED10K00F             | 341400000       |
| R25,27               | RES MF 96.25 OHM 0.1% 1/2W     | 64537     | PME65-T9                 | 326996000       |
| R26                  | RES MF 71.15 OHM 0.1% 1/2W     | 64537     | PME65-T9                 | 326997000       |
| R28                  | RES MF 8.25K 1% 1/4W           | 19701     | 5043ED8K250F             | 341388000       |
| R29,36,47            | RES MF 3.01K 1% 1/4W           | 19701     | 5043ED3K010F             | 341346000       |
| R32,34,39,           | RES MF 61.11 OHM 0.1% 1/2W     | 64537     | PME65-T9                 | 326998000       |
| R33,40,42            | RES MF 247.5 OHM 0.1% 1/2W     | 64537     | PME65-T9                 | 326995000       |
| R35                  | RES MF 6.81K 1% 1/4W           | 19701     | 5043ED6K810F             | 341380000       |
| R38                  | RES MF 1.00K 1% 1/4W           | 19701     | 5043ED1K000F             | 341300000       |
| R41                  | RES MF 30.56 OHM 0.1% 1/2W     | 64537     | PME65-T9                 | 32699200A       |
| R43                  | RES MF 61.11 OHM 0.1% 1/2W     | 64537     | PME65-T9                 | 326998000       |
| R44                  | RES MF 6.19K 1% 1/4W           | 19701     | 5043ED6K190F             | 341376000       |
| R49                  | RES MF 1.50K 1% 1/4W           | 19701     | 5043ED1K500F             | 341317000       |
| RT1                  | THERMISTOR 1.0K DISK RDL LEADS | 00241     | 140-102FAG-A01           | 32501700A       |
| U1                   | IC OP-16GJ OP AMP              | 06665     | OP-16GJ                  | 535048000       |
| Y1                   | CRYSTAL 30 MHz QTZ 3RD HC-43/U | 32897     | 30MHz HC18/V             | 547037000       |

TABLE 7-2. REPLACEABLE PARTS (Cont.)

04312800A REV: A\* PWA '4300' INTERFACE 30 MHz  
MODEL: 4321/4322

| REFERENCE DESIGNATOR | DESCRIPTION      | FED. CODE | MANUFACTURER PART NUMBER | BEC PART NUMBER |
|----------------------|------------------|-----------|--------------------------|-----------------|
| J45                  | SOCKET IC 16 PIN | 06776     | ICN-163-S3-G             | 473042000       |

04312900B REV: DD PWA '4300' 30 MHz DIGITAL  
MODEL: 4321/4322

| REFERENCE DESIGNATOR | DESCRIPTION                | FED. CODE | MANUFACTURER PART NUMBER | BEC PART NUMBER |
|----------------------|----------------------------|-----------|--------------------------|-----------------|
| C1-5                 | CAP CER 0.1uF 20% 50V      | 04222     | SR215E104MAA             | 224268000       |
| J44                  | SOCKET IC 16 PIN           | 06776     | ICN-163-S3-G             | 473042000       |
| Q1                   | TRANS NPN 2N3904           | 04713     | 2N3904                   | 528071000       |
| R1,7-8               | RES MF 10.0K 1% 1/4W       | 19701     | 5043ED10K00F             | 341400000       |
| R2                   | RES MF 681 OHM 1% 1/4W     | 19701     | 5043ED681ROF             | 341280000       |
| U1                   | D/A CONVERTER 565          | 51640     | AD565AJD                 | 421034000       |
| U2                   | IC 71055 INTERFACE         | 52464     | MSM82C55A-SRS            | 53441100A       |
| U3                   | IC EEPROM 2804A MOS 24DIP  | 60395     | X2804AP-45               | 534401000       |
| U4                   | IC 74LS645 TRANSCEIVER     | 01295     | SN74LS645N               | 534382000       |
| U5                   | IC 74LS08 QUAD 2 INPUT AND | 18324     | SN74LS08N                | 534156000       |
| U6                   | IC OP-07EP OP AMP          | 06665     | OP-07EP                  | 535110000       |
| XU1,3                | SOCKET IC 24 PIN           | 06776     | ICN-246-S4-G             | 473043000       |
| XU2                  | SOCKET IC 40 PIN           | 06776     | ICN-406-S4-TG            | 473052000       |
| XU4                  | SOCKET IC 20 PIN           | 06776     | ICN-203-S3-G             | 473065000       |
| XU5                  | SOCKET IC 14 PIN           | 06776     | ICN-143-S3-G             | 473019000       |
| XU6                  | SOCKET IC 8 PIN            | 06776     | ICN-083-S3-G             | 473041000       |

04312801A REV: A\* PWA '4300' INTERFACE 30 MHz  
MODEL: 4321/4322

| REFERENCE DESIGNATOR | DESCRIPTION | FED. CODE | MANUFACTURER PART NUMBER | BEC PART NUMBER |
|----------------------|-------------|-----------|--------------------------|-----------------|
| W4                   | CABLE ASSY  | 04901     | 57222702A                | 57222702A       |

04313000A REV: M\* '4300' 30 MHz GENERATOR  
MODEL: 4300

| REFERENCE DESIGNATOR | DESCRIPTION                   | FED. CODE | MANUFACTURER PART NUMBER | BEC PART NUMBER |
|----------------------|-------------------------------|-----------|--------------------------|-----------------|
| A1                   | PWA '4300' 30 MHz OSCILLATOR  | 04901     | 04312700F                | 04312700F       |
| A2                   | PWA '4300' INTERFACE 30 MHz   |           |                          | 04312801A       |
| C1-8                 | CAP FT 3000pF 100V            | 32575     | 859617-1                 | 227123000       |
| C9                   | CAP MICA 18pF 5% 300V         | 14655     | CD5CC180J                | 205046000       |
| J43                  | CONNECTOR TYPE "N"            | 24253     | 4889                     | 47945500A       |
| L1                   | INDUCTOR 0.05uH               | 04901     | 40044700A                | 40044700A       |
| W46                  | CABLE ASSY WIRE 24GA 9C 2.00L | 04901     | 57122300A                | 57122300A       |

Section 7  
Parts List

TABLE 7-2. REPLACEABLE PARTS (Cont.)

| 04313100A REV: B* PWA '4300' 50 MHz CALIBRATOR<br>MODEL: 4323/4324 |                            |           |                          |                 |
|--------------------------------------------------------------------|----------------------------|-----------|--------------------------|-----------------|
| REFERENCE DESIGNATOR                                               | DESCRIPTION                | FED. CODE | MANUFACTURER PART NUMBER | BEC PART NUMBER |
| AR1                                                                | IC 301A OP AMP             | 27014     | LM301AN                  | 535902000       |
| C1                                                                 | CAP CER 470pF 10% 500V     | 33883     | TYPE JF                  | 224219000       |
| C2                                                                 | CAP MICA 100pF 5% 300V     | 20307     | DM5-FC101J               | 205006000       |
| C3,7                                                               | CAP EL 10uF 20% 25V        | 34217     | SM-25-VB-10-M            | 283336000       |
| C4,12                                                              | CAP VAR CER 3.5-18pF 250V  | 91293     | 9373                     | 281011000       |
| C5                                                                 | CAP CER 1000pF 10% 600V    | 16546     | CE-102                   | 224310000       |
| C8                                                                 | CAP CER 0.01uF 100V        | 33883     | BT Z5U                   | 224119000       |
| C9                                                                 | CAP MICA 36pF 5% 300V      | 14655     | CD5EC360J                | 205003000       |
| C10                                                                | CAP MICA 200pF 5% 100V     | 14655     | CD5FA201J                | 205024000       |
| C11                                                                | CAP MICA 10pF 5% 300V      | 14655     | CD5CC100J                | 205002000       |
| CR1-2                                                              | DIODE HSCH1001 (1N6263)    | 28480     | HSCH-1001                | 530174000       |
| CR3                                                                | DIODE MV-1650              | 04713     | MV1650                   | 530762000       |
| L1                                                                 | INDUCTOR 4.7uH 10%         | 24226     | 10/471                   | 400384000       |
| L2                                                                 | INDUCTOR 0.56uH 10%        | 24226     | 10/560                   | 400382000       |
| L3                                                                 | INDUCTOR 0.022 uH          | 04901     | 40044400A                | 40044400A       |
| Q1                                                                 | TRANS NPN 2N3904           | 04713     | 2N3904                   | 528071000       |
| R1                                                                 | RES MF 1.50K 1% 1/4W       | 19701     | 5043ED1K500F             | 341317000       |
| R2-3,6                                                             | RES MF 100K 1% 1/4W        | 19701     | 5043ED100K0F             | 341500000       |
| R4                                                                 | RES VAR 1K 10% 0.5W        | 32997     | 3299X-1-102              | 311410000       |
| R7                                                                 | RES MF 2.43K 1% 1/4W       | 19701     | 5043ED2K430F             | 341337000       |
| R8-9                                                               | RES MF 1.00K 1% 1/4W       | 19701     | 5043ED1K000F             | 341300000       |
| R10                                                                | RES MF 10.0K 1% 1/4W       | 19701     | 5043ED10K00F             | 341400000       |
| R11                                                                | RES MF 5.11K 1% 1/4W       | 19701     | 5043ED5K110F             | 341368000       |
| R12                                                                | RES MF 1.21K 1% 1/4W       | 19701     | 5043ED1K210F             | 341308000       |
| R13                                                                | RES MF 1.30K 1% 1/4W       | 19701     | 5043ED1K300F             | 341311000       |
| R14                                                                | RES MF 75.0 OHM 1% 1/4W    | 19701     | 5043ED75R00F             | 341184000       |
| R15                                                                | RES MF 50.00 OHM 0.1% 1/4W | 64537     | PME55-T9                 | 325916000       |
| U1                                                                 | IC AD581JH VOLT REF        | 51640     | AD581JH                  | 535053000       |

| 04313200B REV: C* '4323' 50MHz CAL ASSY<br>MODEL: 4323/4324 |                               |           |                          |                 |
|-------------------------------------------------------------|-------------------------------|-----------|--------------------------|-----------------|
| REFERENCE DESIGNATOR                                        | DESCRIPTION                   | FED. CODE | MANUFACTURER PART NUMBER | BEC PART NUMBER |
| A1                                                          | PWA '4300' 50 MHz CALIBRATOR  | 04901     | 04313100A                | 04313100A       |
| C6                                                          | CAP FT 1000pF 20% 500V        | 59660     | 2499-003-X550102M        | 227105000       |
| W26                                                         | CABLE ASSY WIRE 24GA 2C 8.50L | 04901     | 57222904A                | 57222904A       |

| 04313400A REV: G* '4321/22' 30 MHz CAL ASSY FT/RE<br>MODEL: 4321 |                           |           |                          |                 |
|------------------------------------------------------------------|---------------------------|-----------|--------------------------|-----------------|
| REFERENCE DESIGNATOR                                             | DESCRIPTION               | FED. CODE | MANUFACTURER PART NUMBER | BEC PART NUMBER |
| A3                                                               | '4300' 30 MHz GENERATOR   |           |                          | 04313000B       |
| A4                                                               | PWA '4300' 30 MHz DIGITAL | 04904     | 04321900B                | 04321900B       |

TABLE 7-2. REPLACEABLE PARTS (Cont.)

| 04311001B REV: E* '4311' INPUT ASSY |                                |                  |                                 |                        |
|-------------------------------------|--------------------------------|------------------|---------------------------------|------------------------|
| <u>REFERENCE DESIGNATOR</u>         | <u>DESCRIPTION</u>             | <u>FED. CODE</u> | <u>MANUFACTURER PART NUMBER</u> | <u>BEC PART NUMBER</u> |
| A1                                  | CHOPPER MODULE ASSEMBLY '4300' |                  |                                 | 04324000A              |
| A2                                  | PWA '4300' INPUT COMMON        |                  |                                 | 04310400E              |
| A3                                  | BRACKET INPUT ASSY             | 04901            | 043111000                       | 043111000              |
| AR1,2                               | (G) IC 3568 OP AMP SELECTED    | 04901            | 535062000                       | 535062000              |
| U1                                  | PROM 4300 A7 U1 INPUT          | 04901            | 5440700C                        | 53440700C              |
| W7                                  | CABLE ASSY (SHIELDED) 16.00L   | 04901            | 57121500A                       | 57121500A              |

| 04311003B INPUT ASSY (THERMAL) 4312<br>MODEL: 4312 |                       |                  |                                 |                        |
|----------------------------------------------------|-----------------------|------------------|---------------------------------|------------------------|
| <u>REFERENCE DESIGNATOR</u>                        | <u>DESCRIPTION</u>    | <u>FED. CODE</u> | <u>MANUFACTURER PART NUMBER</u> | <u>BEC PART NUMBER</u> |
| A1                                                 | CHOPPER #2 ASSEMBLY   | 04901            | 4312202A                        | 04312202A              |
| A2                                                 | PWA INPUT COMMON 4300 | 04901            | 04310400D                       | 04310400E              |
| A3                                                 | BRACKET INPUT ASSY    | 04901            | 043111000                       | 043111000              |
| AR1 - 2                                            | IC OP-27 OP AMP       | 06665            | OP-27-GZ                        | 535115000              |
| U1                                                 | PROM 4300 A7 U1 INPUT | 04901            | 53440700C                       | 53440700C              |
| W7                                                 | CABLE ASSY (SHIELDED) | 04901            | 57121500A                       | 57121500A              |

# SECTION 8 SCHEMATIC DIAGRAMS

## TABLE OF CONTENTS

| Figure.....                                                   | Page      |
|---------------------------------------------------------------|-----------|
| 8-1 Frame Schematic, Sheet 1 of 2 .....<br>83146102C          | 8-3/8-4   |
| 8-2 Frame Schematic, Sheet 2 of 2 .....<br>83146103D          | 8-5       |
| 8-3 Chopper II Component Location .....<br>043106             | 8-6       |
| 8-4 Chopper II Schematic.....<br>83146104C                    | 8-7       |
| 8-5 Input Component Location, Sheet 1 of 2 .....<br>04310400E | 8-8       |
| 8-6 Input Schematic, Sheet 1 of 2 .....<br>83146106D          | 8-9       |
| 8-7 Input Component Location .....<br>04310400E               | 8-10      |
| 8-8 Input Schematic, Sheet 2 of 2 .....<br>83146107F          | 8-11      |
| 8-9 30 MHz Oscillator Component Location .....<br>04312700B   | 8-12      |
| 8-10 30 MHz Oscillator Schematic .....<br>83146108D           | 8-13      |
| 8-11 30 MHz Digital Component Location .....<br>04312900D     | 8-14      |
| 8-12 30 MHz Digital Schematic .....<br>83146109B              | 8-15      |
| 8-13 50 MHz Calibrator Component Location .....<br>04313100A  | 8-16      |
| 8-14 50 MHz Calibrator Schematic .....<br>83146111C           | 8-17/8-18 |
| 8-15 Keyboard Schematic.....<br>83146111C                     | 8-19      |
| 8-16 Bus Component Location .....<br>03210700B                | 8-20      |
| 8-17 Bus Schematic .....<br>83146112B                         | 8-21      |
| 8-18 Control Component Location .....<br>04310300H            | 8-22      |
| 8-19 Control Schematic, Sheet 1 of 3 .....<br>83146113F       | 8-23      |
| 8-20 Control Component Location .....<br>04310300H            | 8-24      |
| 8-21 Control Schematic, Sheet 2 of 3 .....<br>83146114D       | 8-25      |
| 8-22 Control Component Location .....<br>04310300H            | 8-26      |
| 8-23 Control Schematic, Sheet 3 of 3 .....<br>83146115J       | 8-27/8-28 |



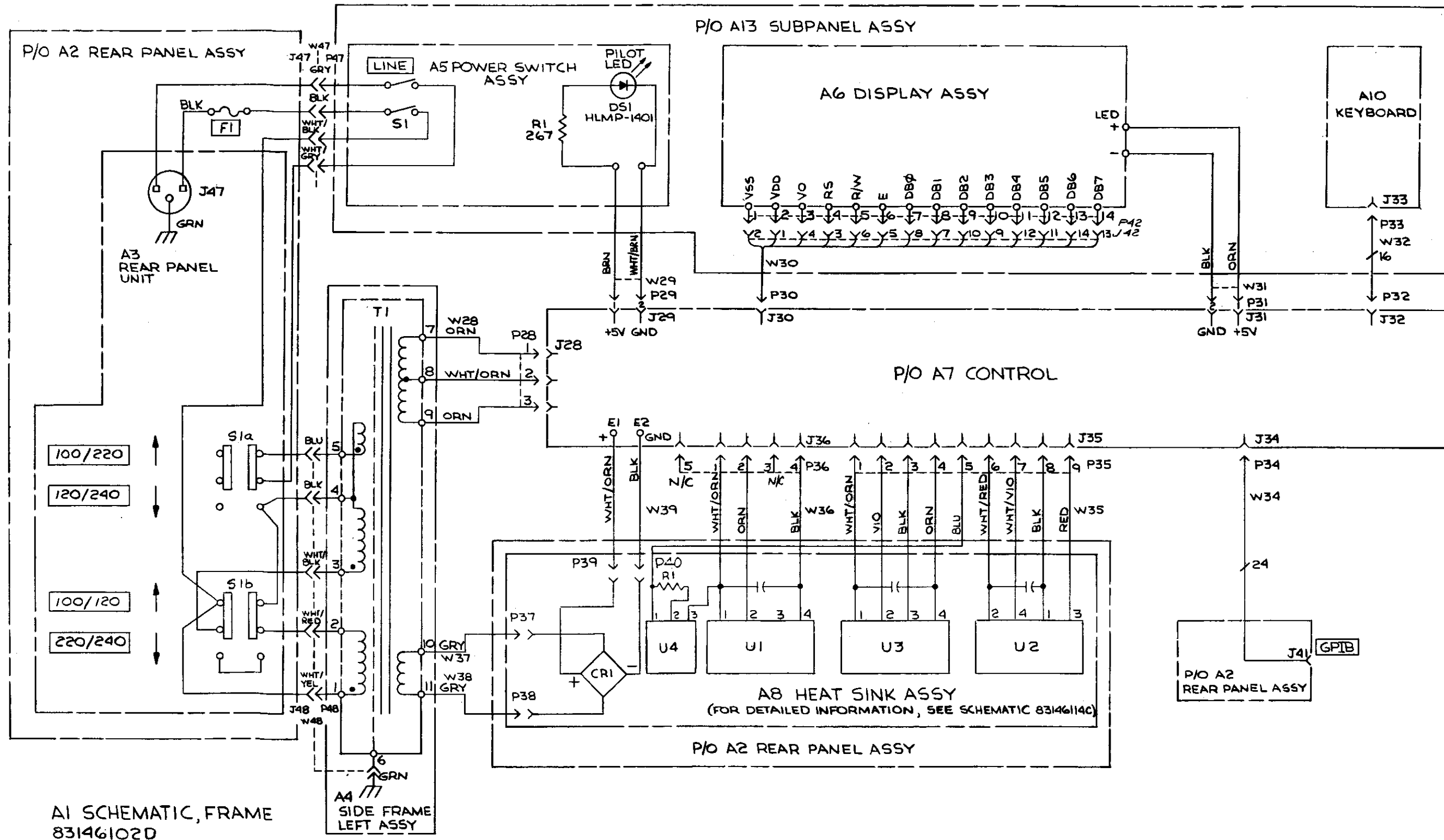

NOTES:

1. 0-DENOTES SOLDER CONNECTION.
2.  -SOLID BOXES DENOTE EXTERNAL MARKINGS.

Figure 8-1. Frame Schematic, Sh 1 of 2  
83146102C

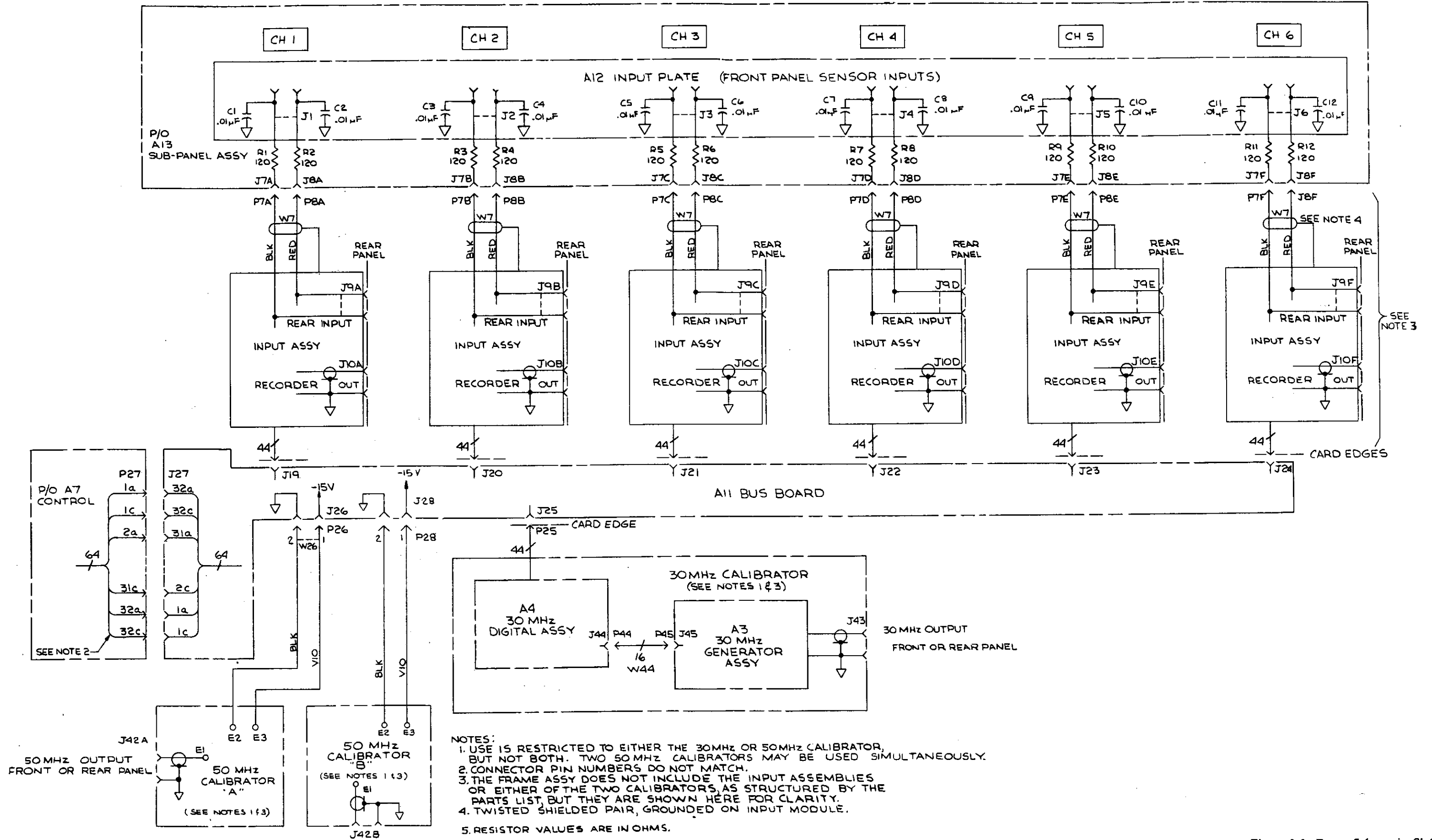

Figure 8-2. Frame Schematic, Sh 2 of 2  
83146103D

Section 8  
Schematic Diagrams

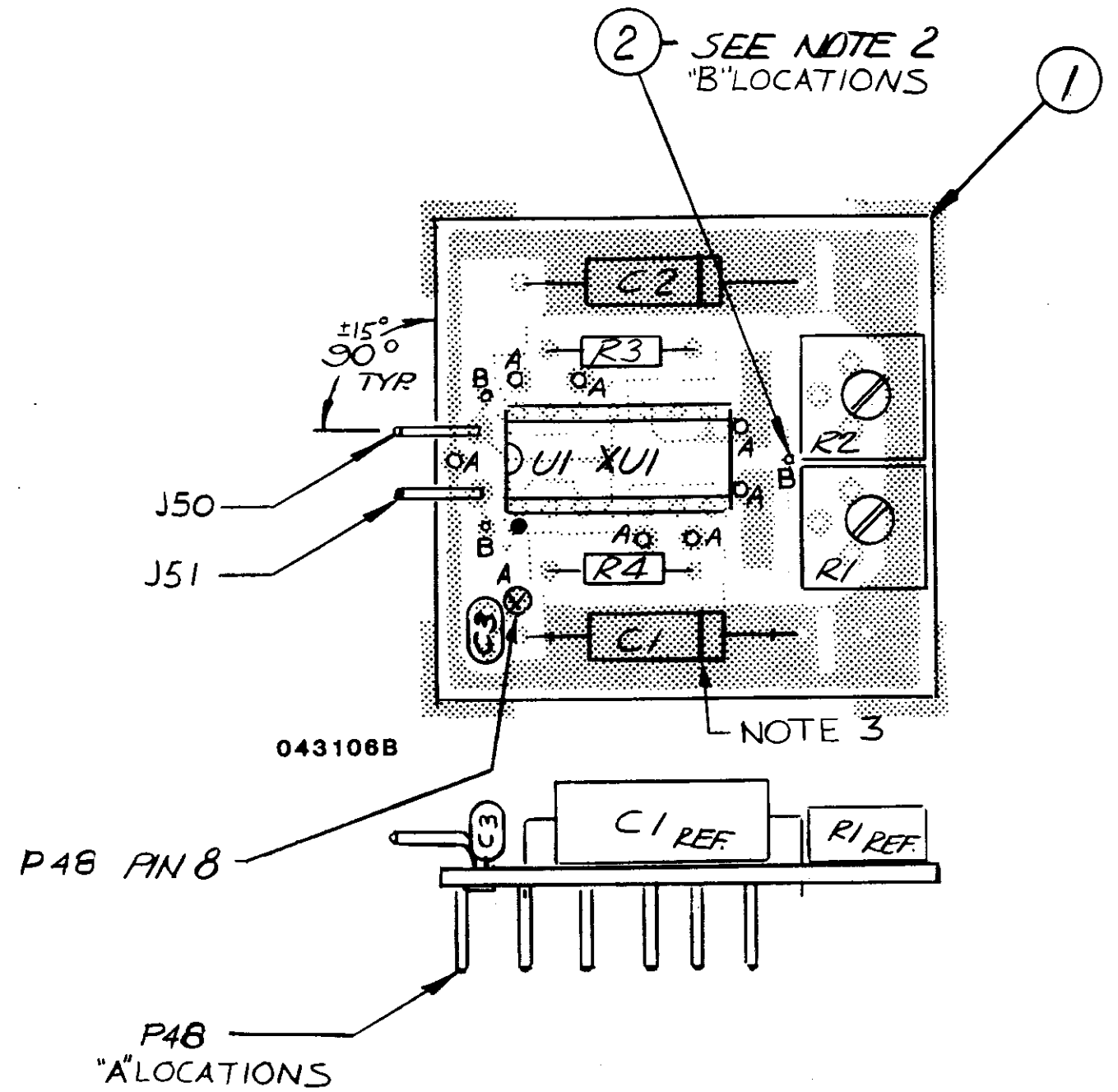

Figure 8-3. Chopper II Component Location  
043106

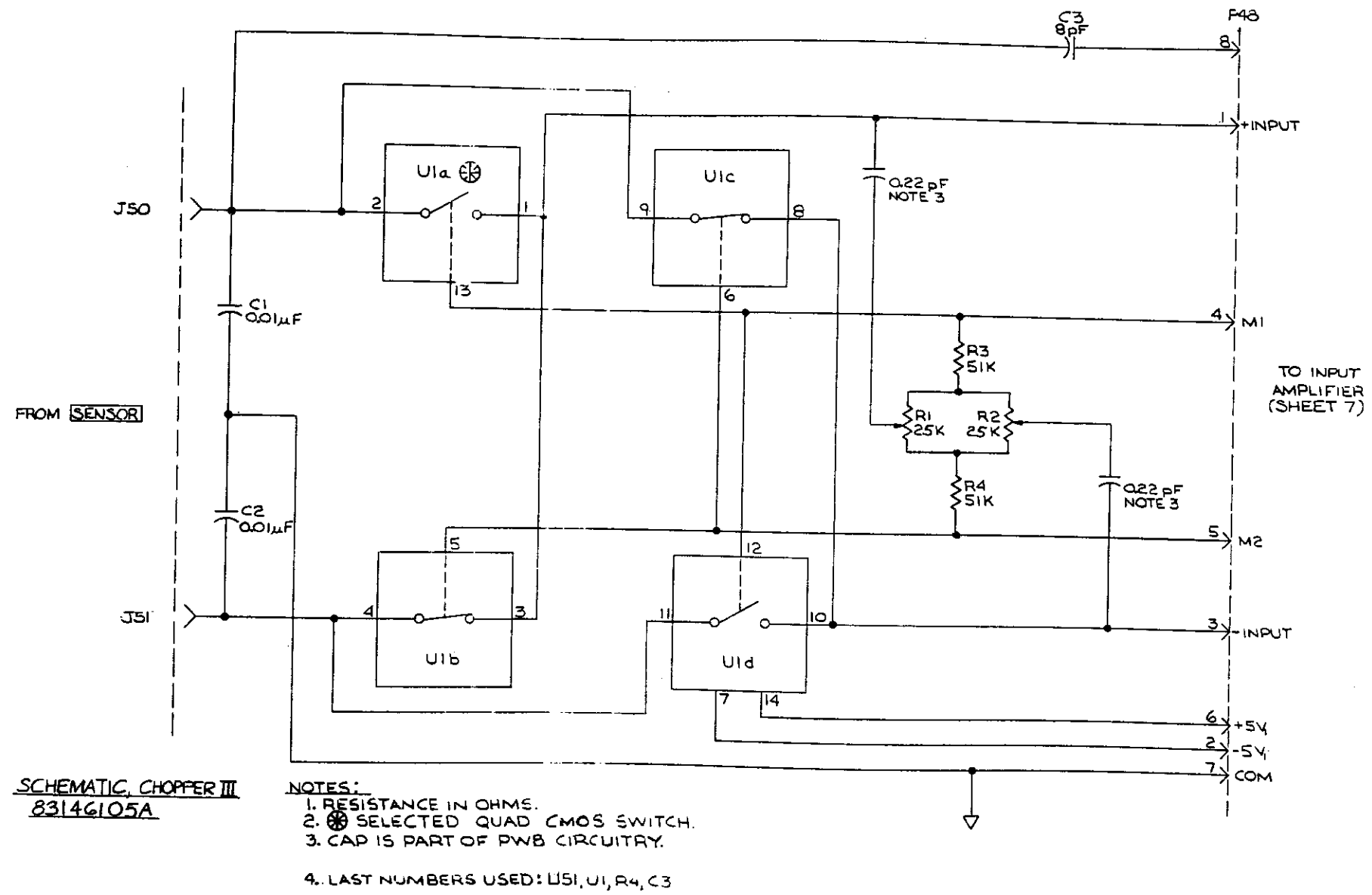
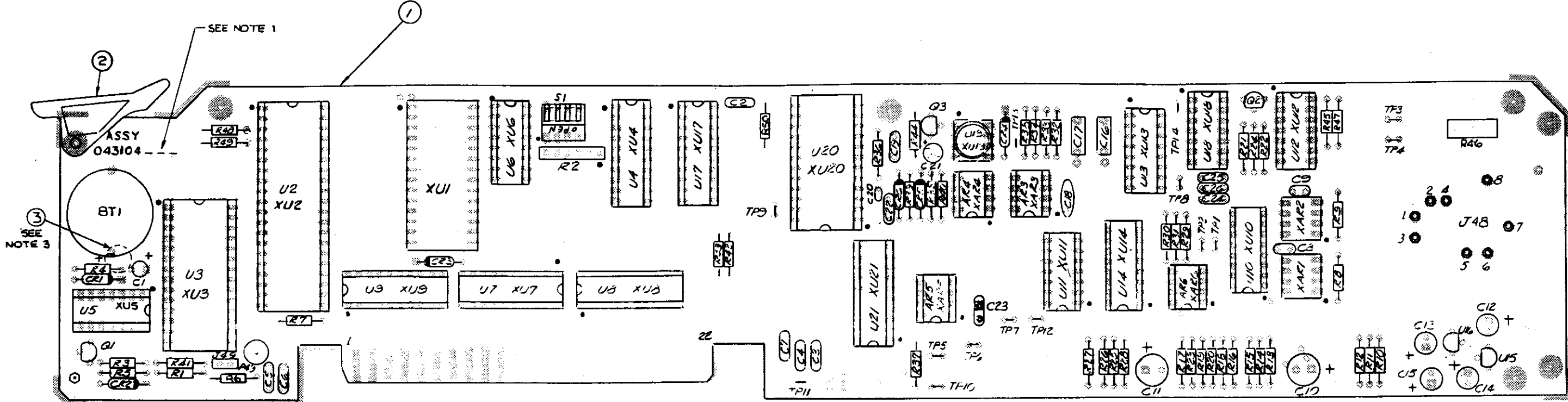

Figure 8-4. Chopper II Schematic

Section 8  
Schematic Diagrams



043104G SHT 1

- NOTES:
1. MARK "FINAL" ASSY. PART NUMBER WITH 1/8" HIGH BLACK CHARACTERS. REFER TO MANUFACTURING ORDER FOR COMPLETE PART NUMBER.
  2. CUT ALL LEADS ON R48, R49, R36, C19, R44, R46, C14, U5, TP11 & C3 TO WITHIN 1/16" OF PWB SURFACE.
  3. INSTALL FELT PAD, ITEM 3, TO BACK SIDE OF BOARD TO COVER BATTERY LEAD.

Figure 8-5. Input Component Location

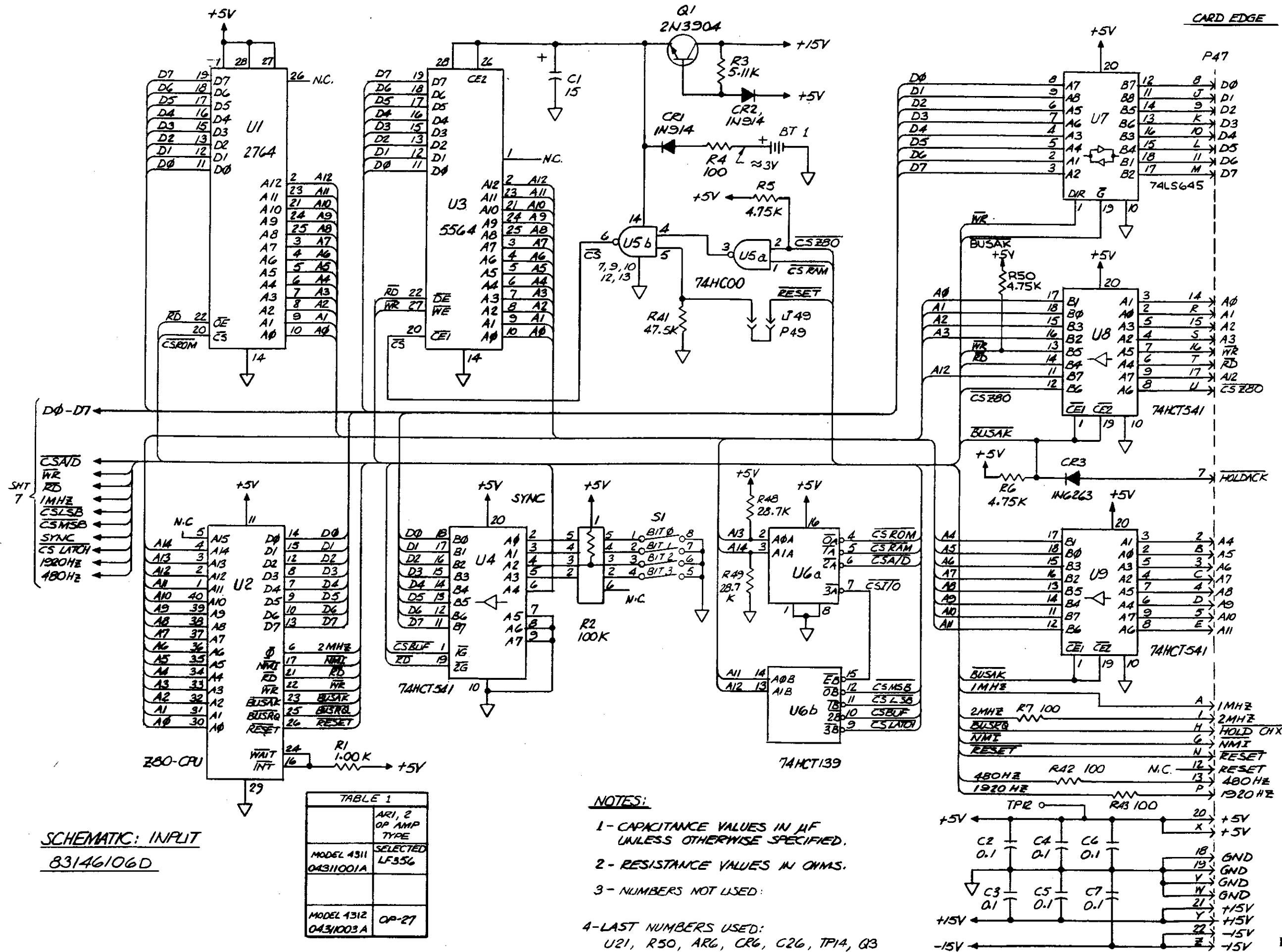
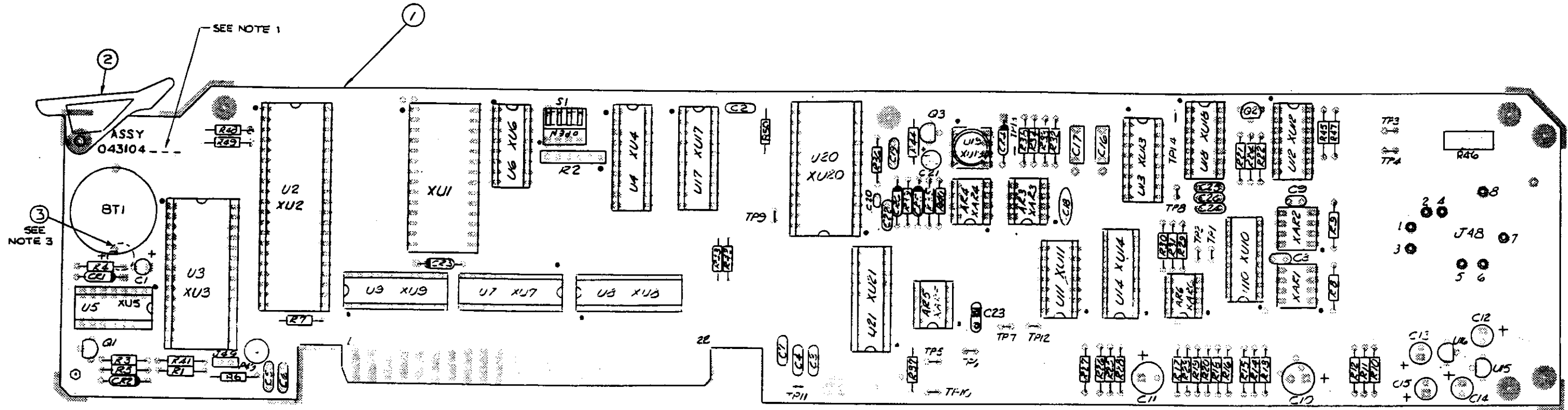

Figure 8-6. Input Schematic, Sh 1 of 2

Section 8  
Schematic Diagrams



043104G SHT 1

NOTES:

1. MARK "FINAL" ASSY. PART NUMBER WITH 1/8" HIGH BLACK CHARACTERS. REFER TO MANUFACTURING ORDER FOR COMPLETE PART NUMBER.
2. CUT ALL LEADS ON R48, R49, R36, C19, R44, R46, C14, U5, TP1 & C3 TO WITHIN 1/16" OF PWB SURFACE.
3. INSTALL FELT PAD, ITEM 3, TO BACK SIDE OF BOARD TO COVER BATTERY LEAD.

Figure 8-7. Input Component Location

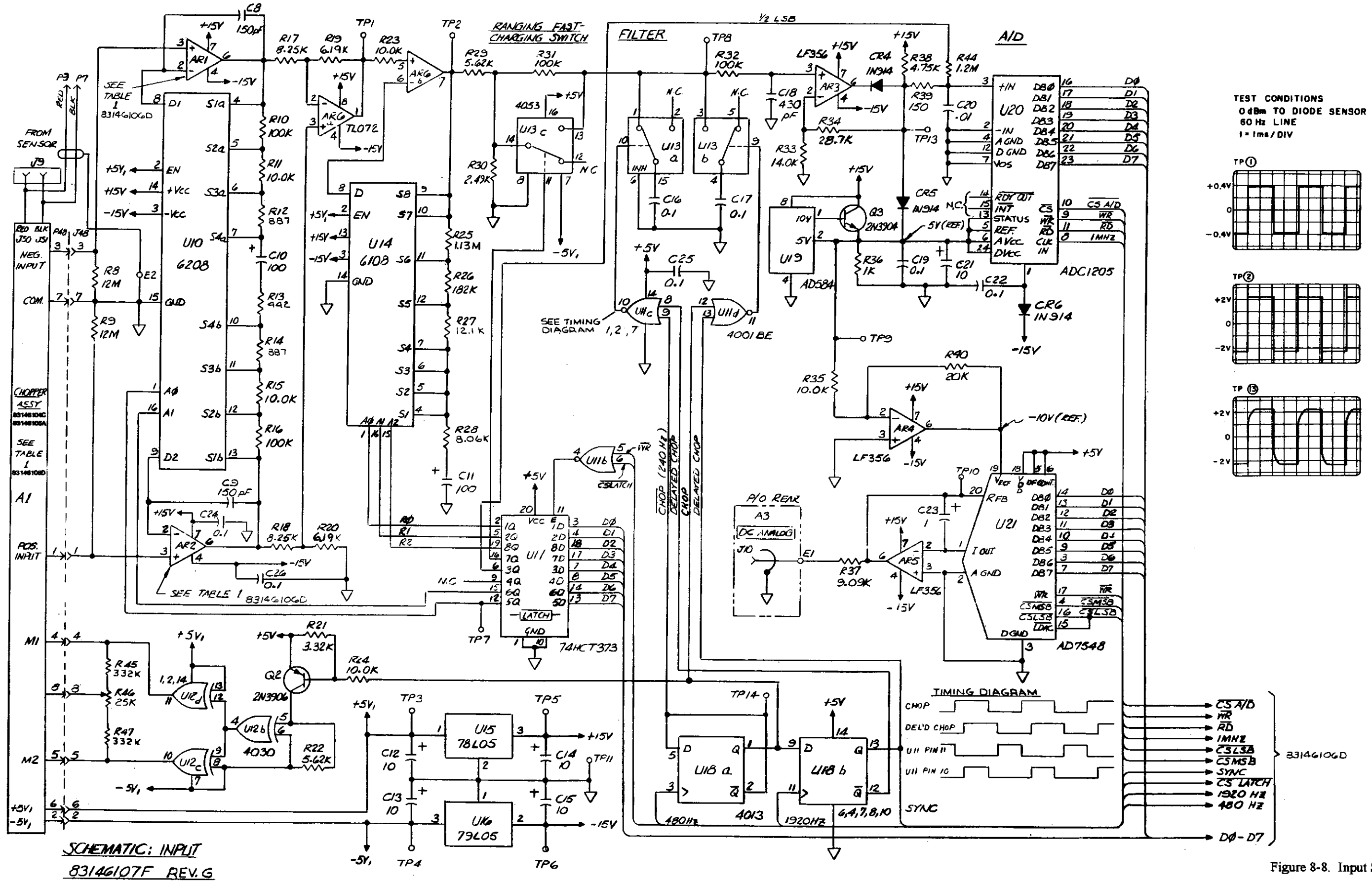
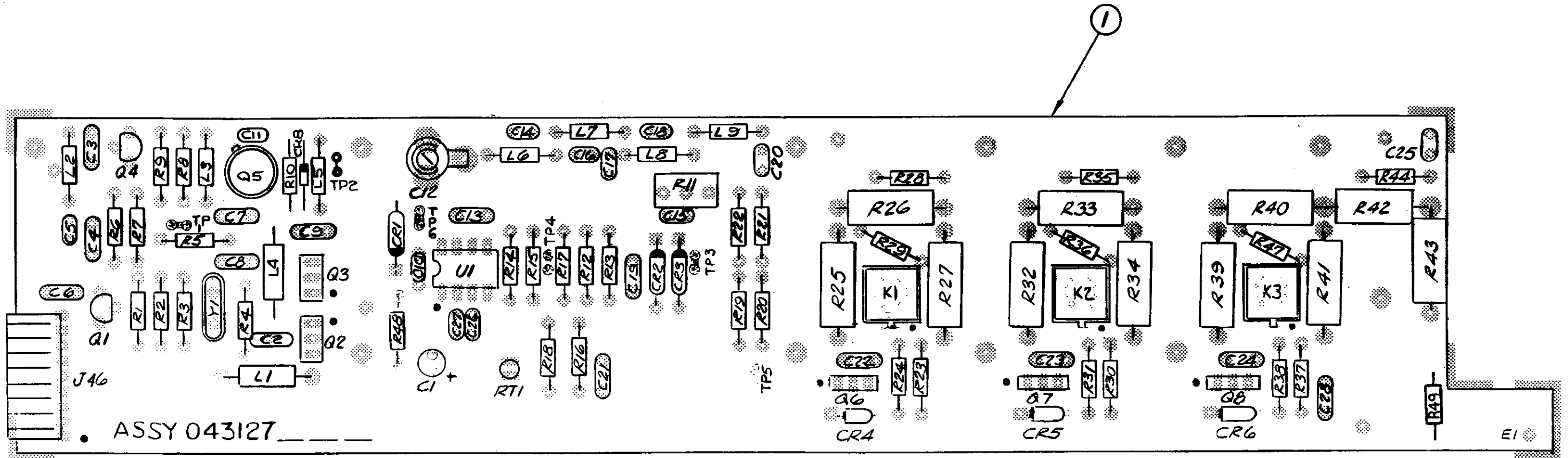

Figure 8-8. Input Schematic, Sh 2 of 2





043127H

Figure 8-9. 30 MHz Oscillator Component Location

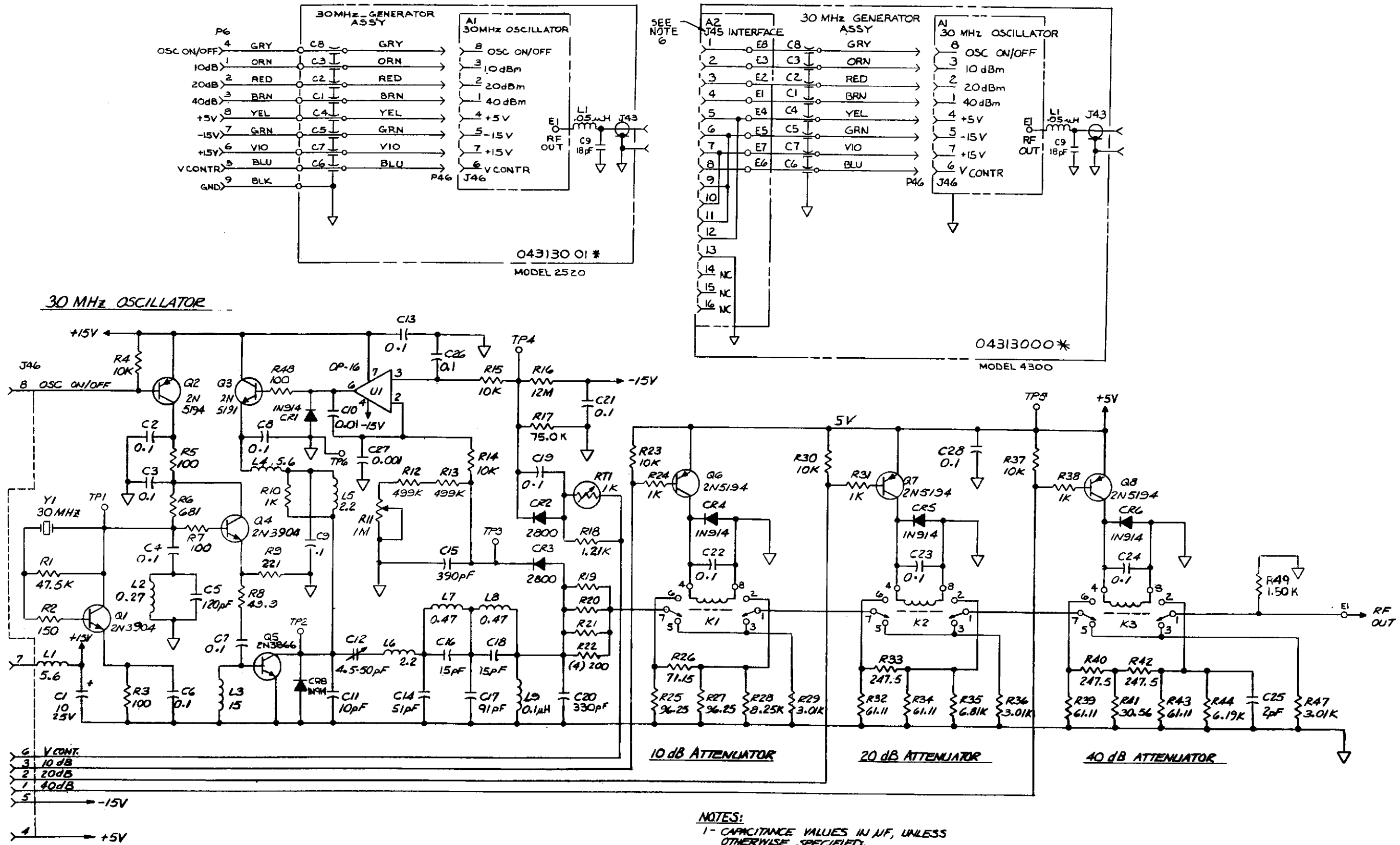

83146108E REV.K1

- NOTES:**
- 1- CAPACITANCE VALUES IN  $\mu$ F, UNLESS OTHERWISE SPECIFIED.
  - 2- RESISTANCE VALUES IN OHMS.
  - 3- INDUCTANCE VALUES IN MH.
  - 4- NUMBERS NOT USED: CR7, R45, R46
  - 5- LAST NUMBERS USED: C28, CR8, L9, Q8, R49, TP6
  6. J45 NOT USED ON 04313002A.

Figure 8-10. 30 MHz Oscillator Schematic

Section 8  
Schematic Diagrams

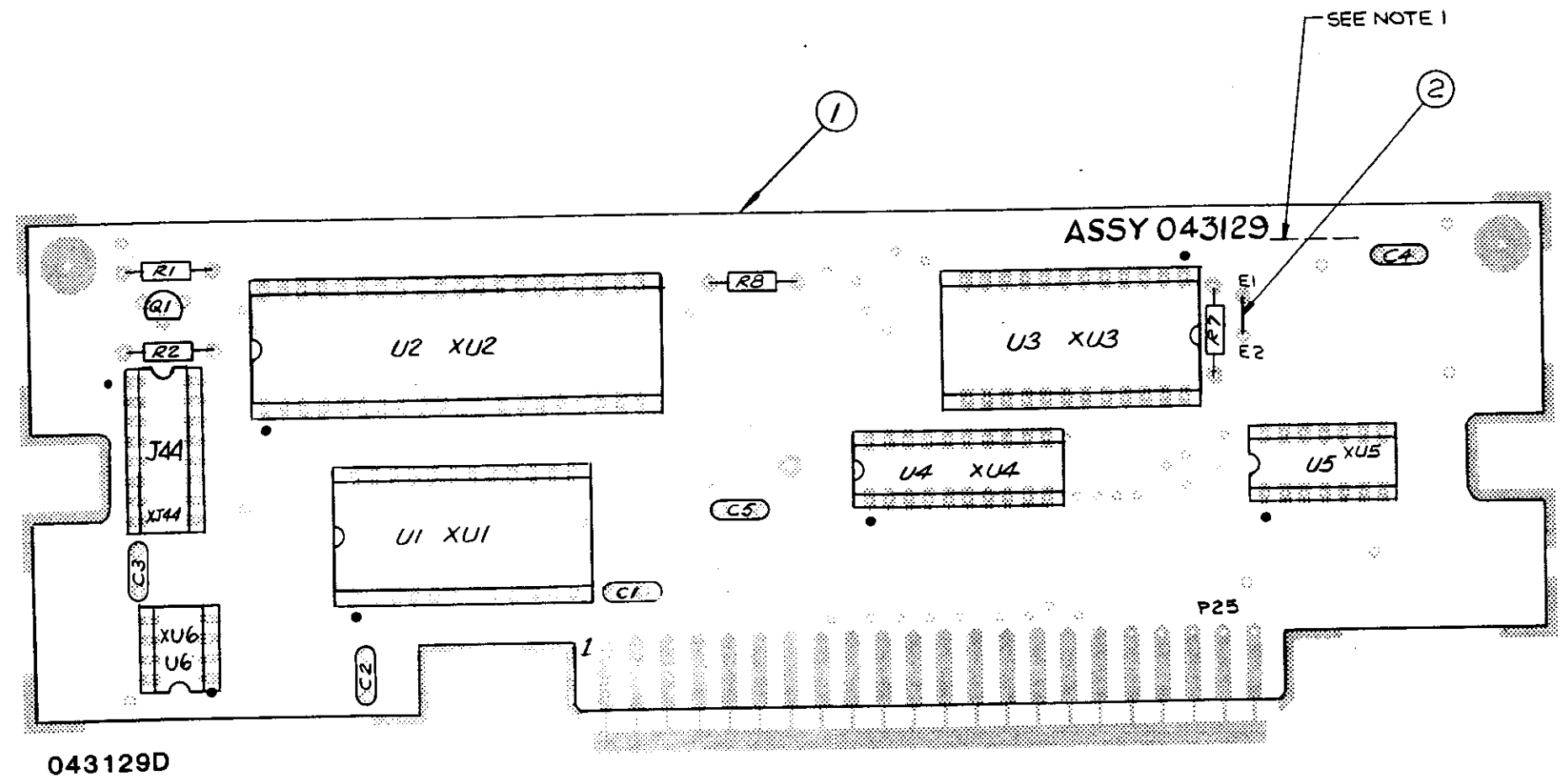

NOTE:  
1. MARK "FINAL" ASSY PART NUMBER WITH 1/8" HIGH BLACK CHARACTERS. REFER TO MANUFACTURING ORDER FOR COMPLETE PART NUMBER.

Figure 8-11. 30 MHz Digital Component Location

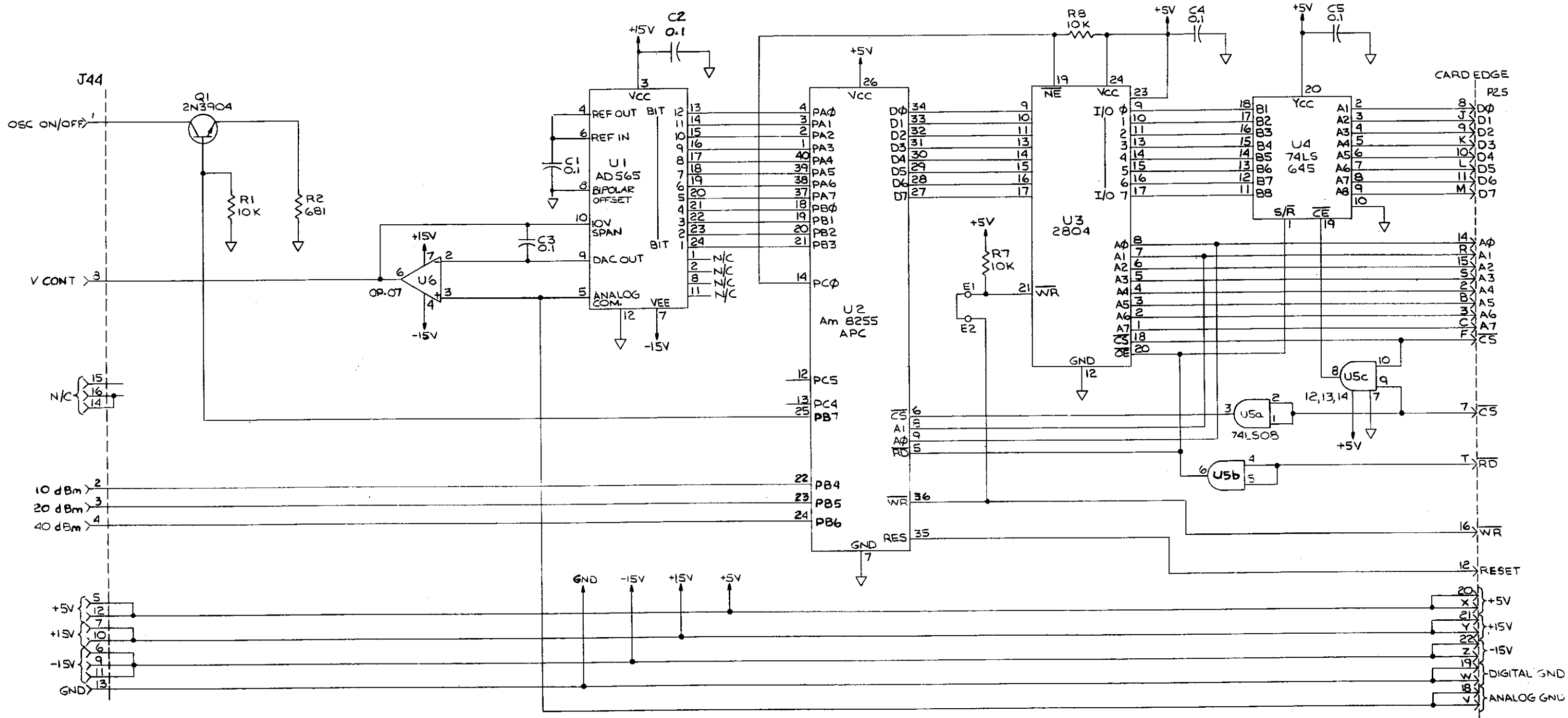

SCHMATIC, 30MHz DIGITAL  
83146109B REV.C

- NOTES:  
 1. CAPACITANCE VALUES IN  $\mu$ F UNLESS OTHERWISE SPECIFIED.  
 2. RESISTANCE VALUES IN OHMS.  
 3. LAST NUMBERS USED:  
 R8, C5, U6

Figure 8-12. 30 MHz Digital Schematic

Section 8  
Schematic Diagrams

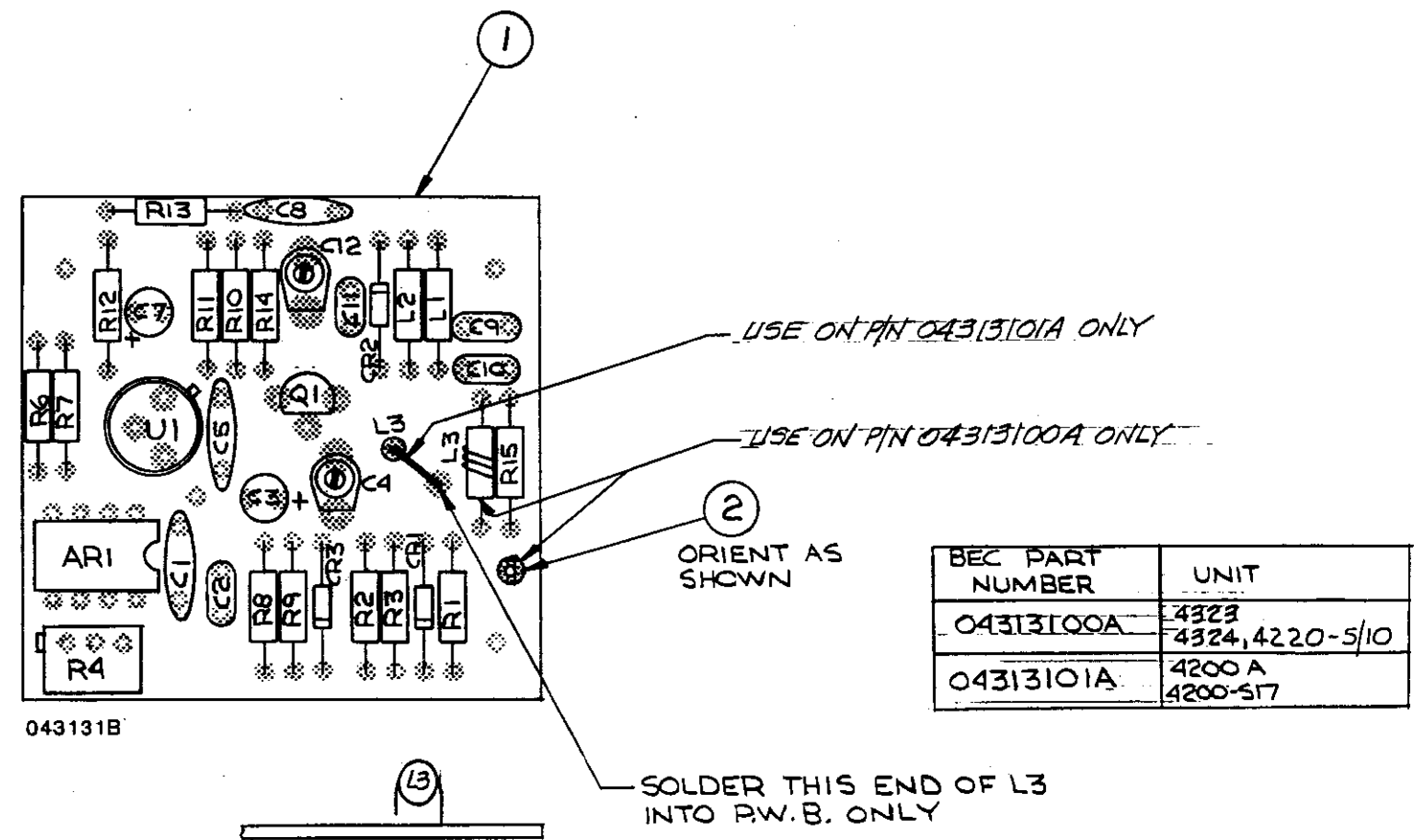

Figure 8-13. 50 MHz Calibrator Component Location

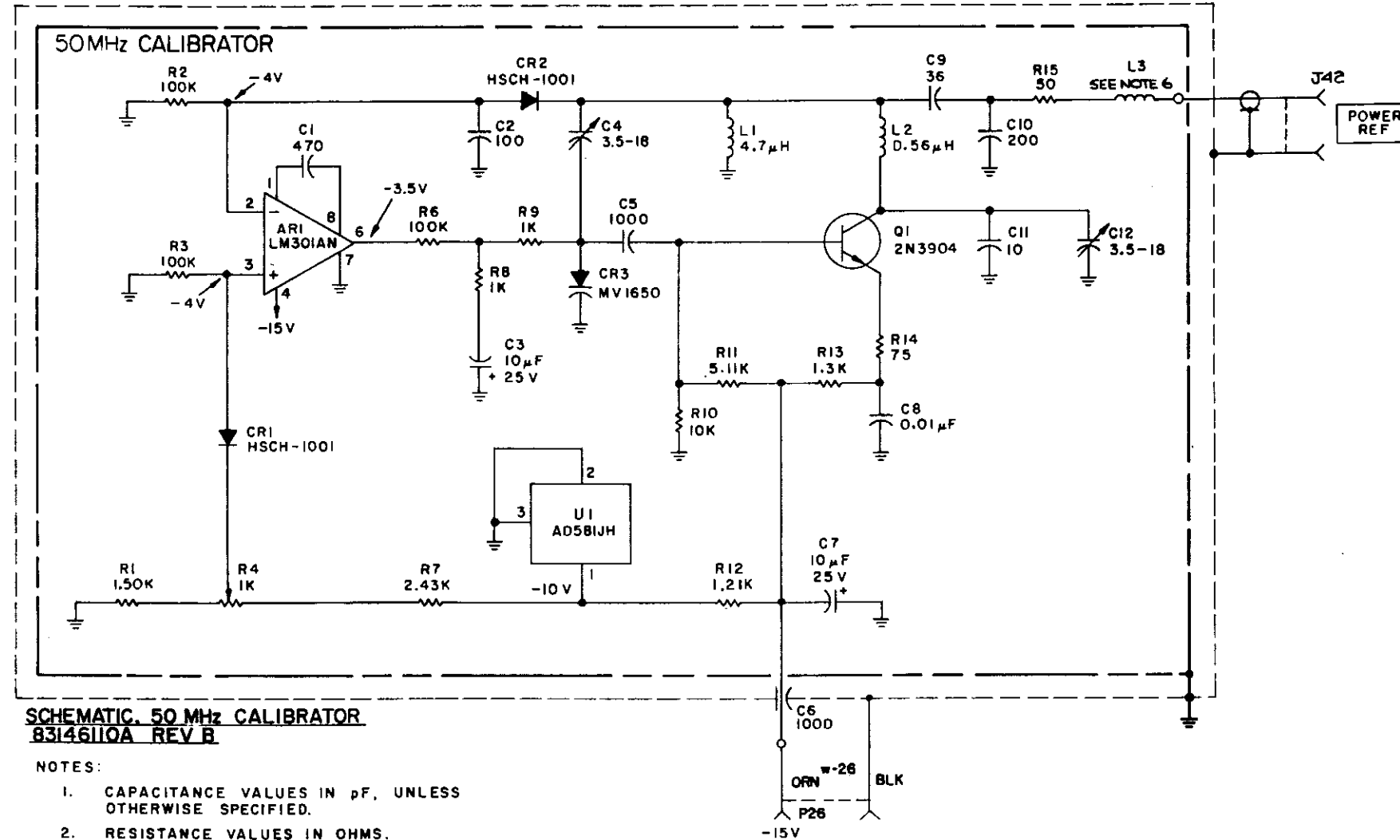

Figure 8-14. 50 MHz Calibrator Schematic

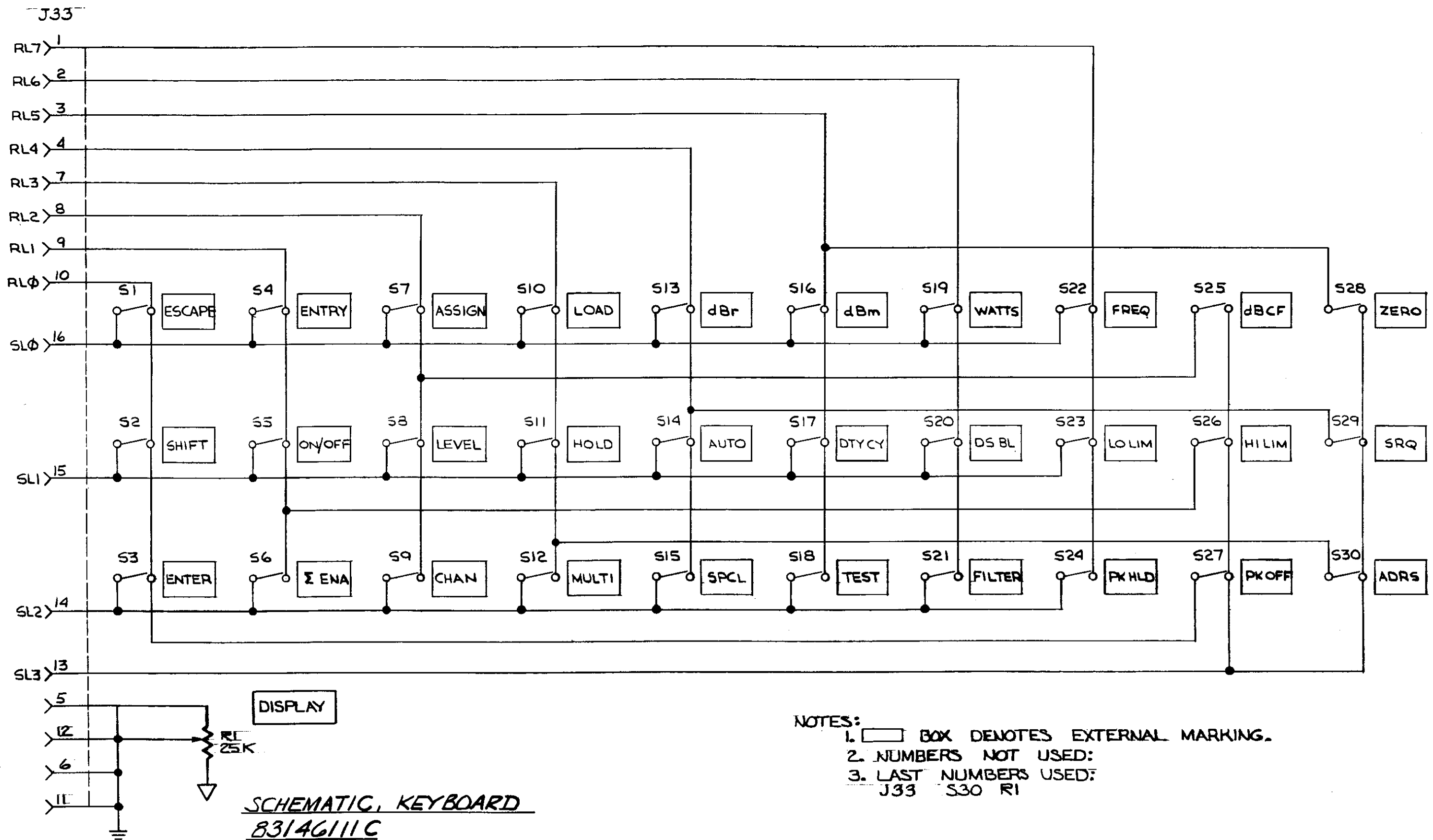
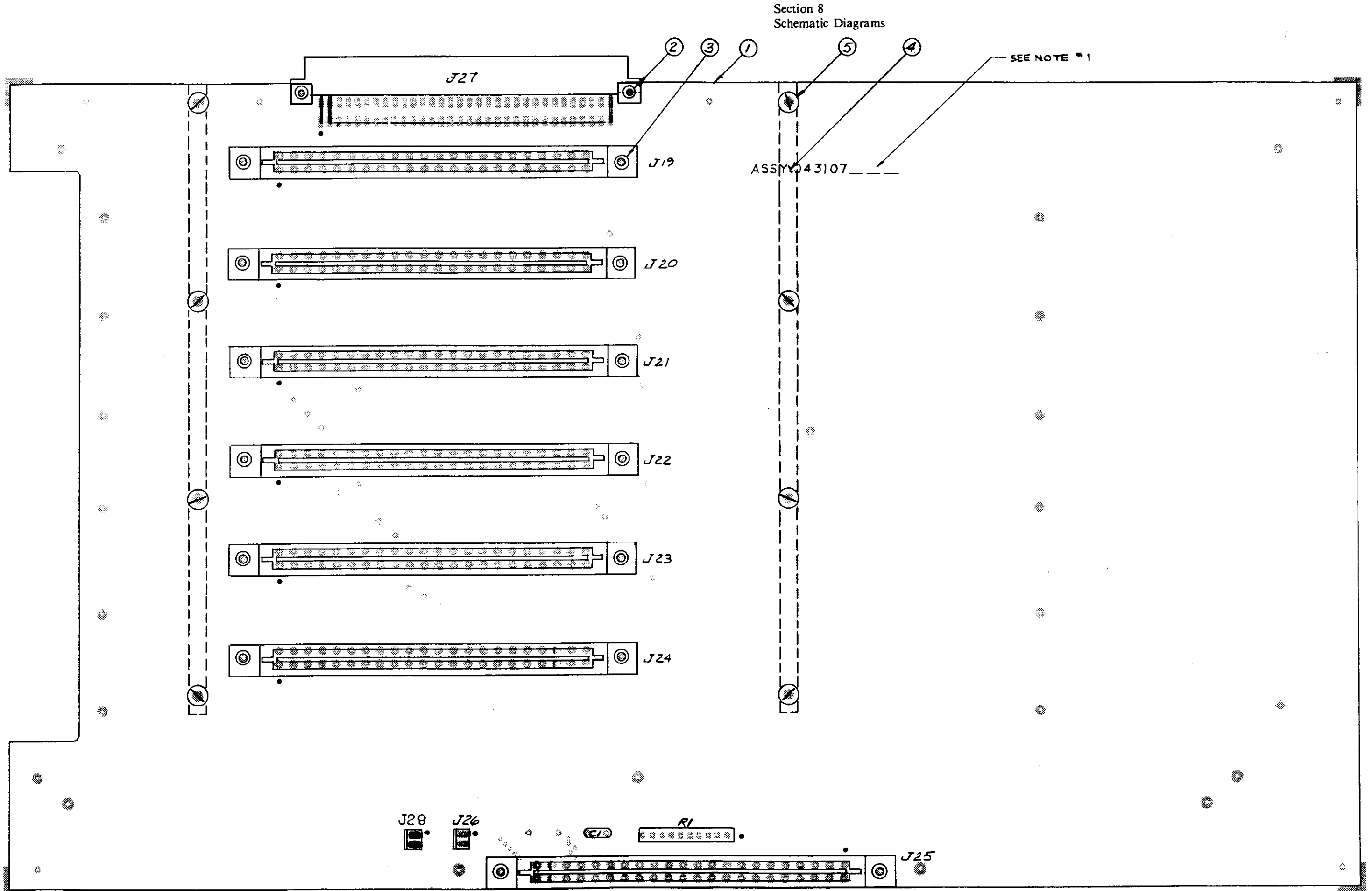

Figure 8-15. Keyboard Schematic

Section 8  
Schematic Diagrams



SEE NOTE #1

ASSY 43107

J27

J19

J20

J21

J22

J23

J24

J28

J26

CI

RI

J25

043107B

Figure 8-16. Bus Component Location



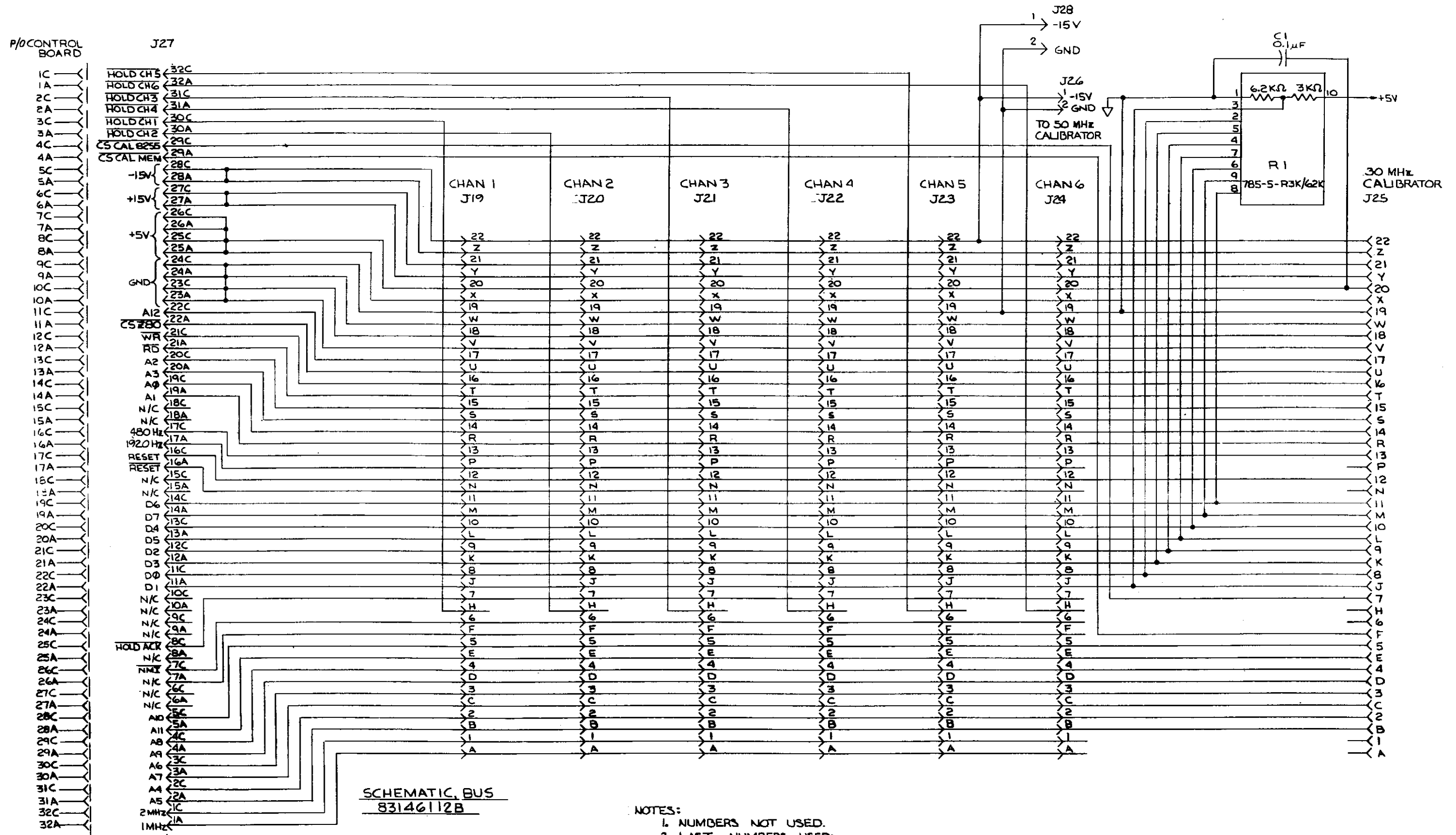

Figure 8-17. Bus Schematic

Section 8  
Schematic Diagrams

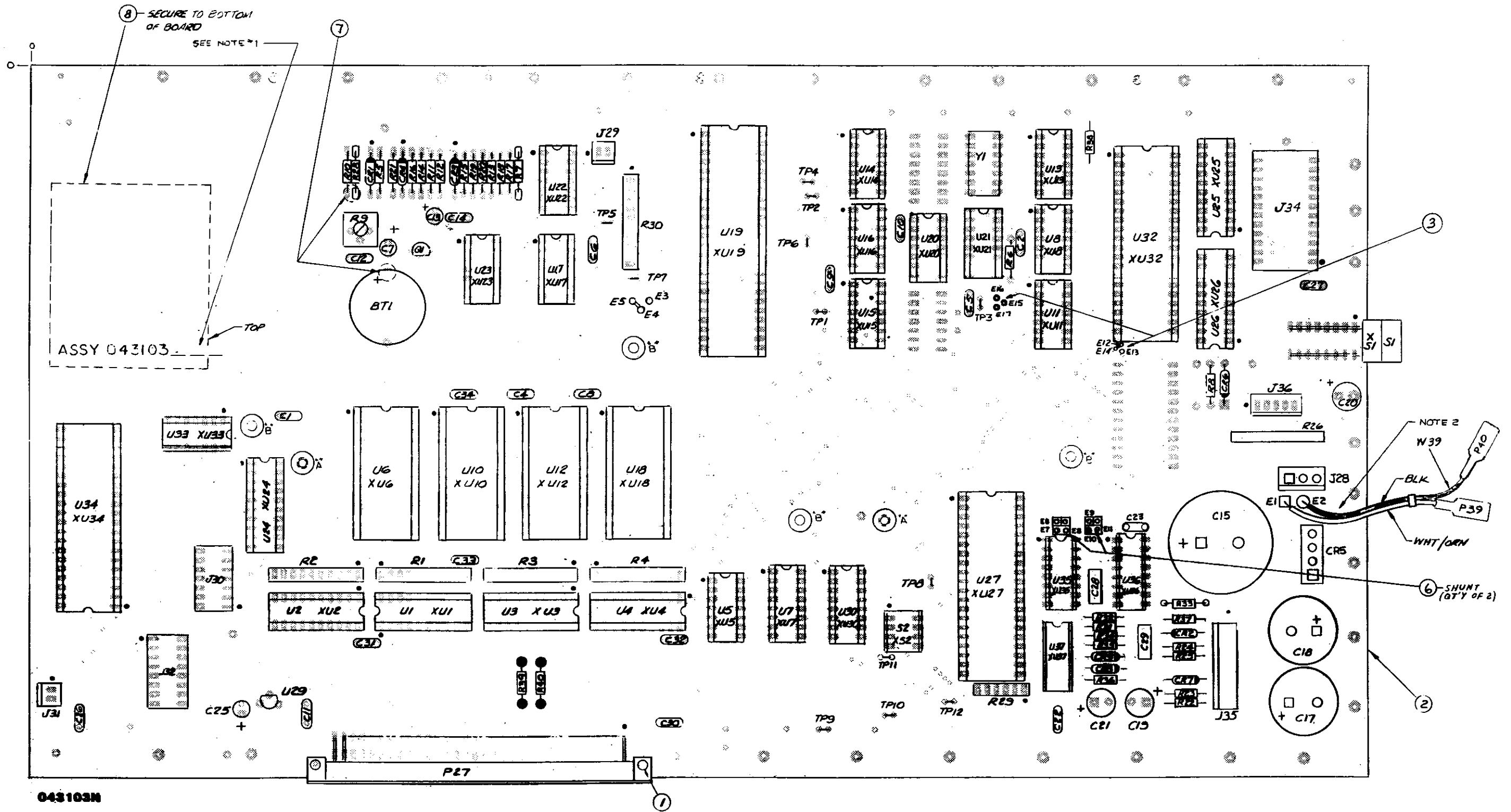

Figure 8-18. Control Component Location

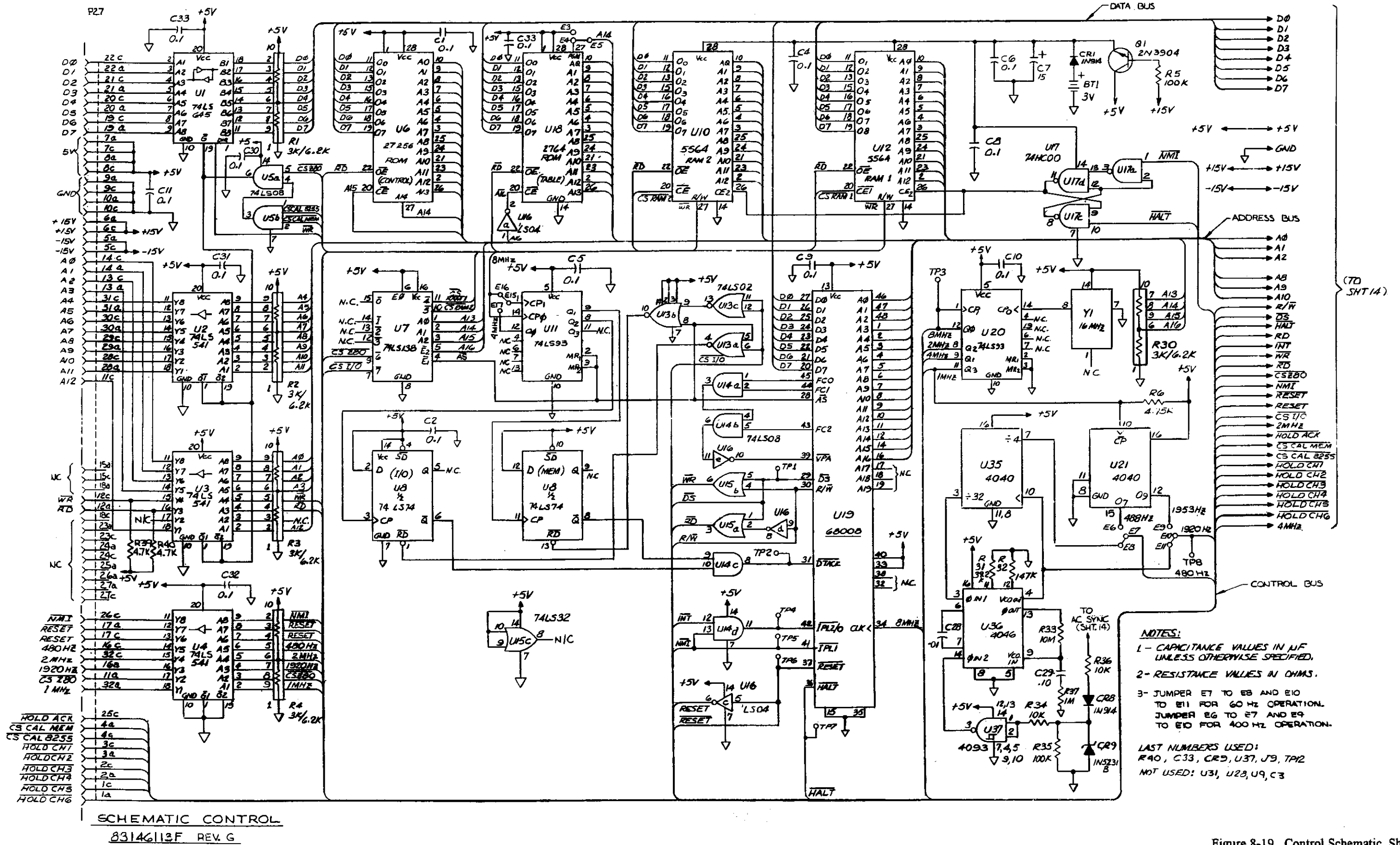

Figure 8-19. Control Schematic, Sh 1 of 3

Section 8  
Schematic Diagrams

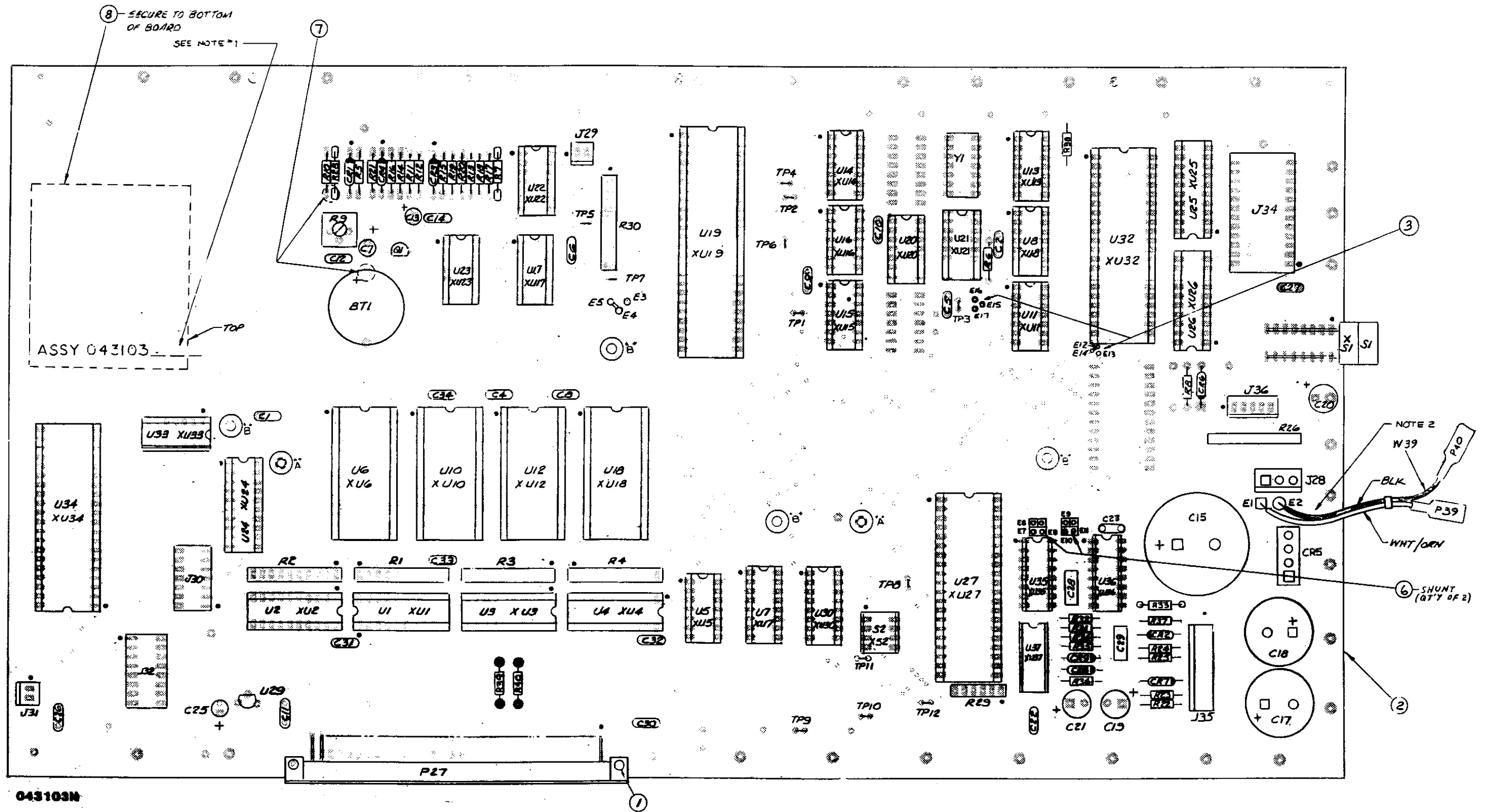
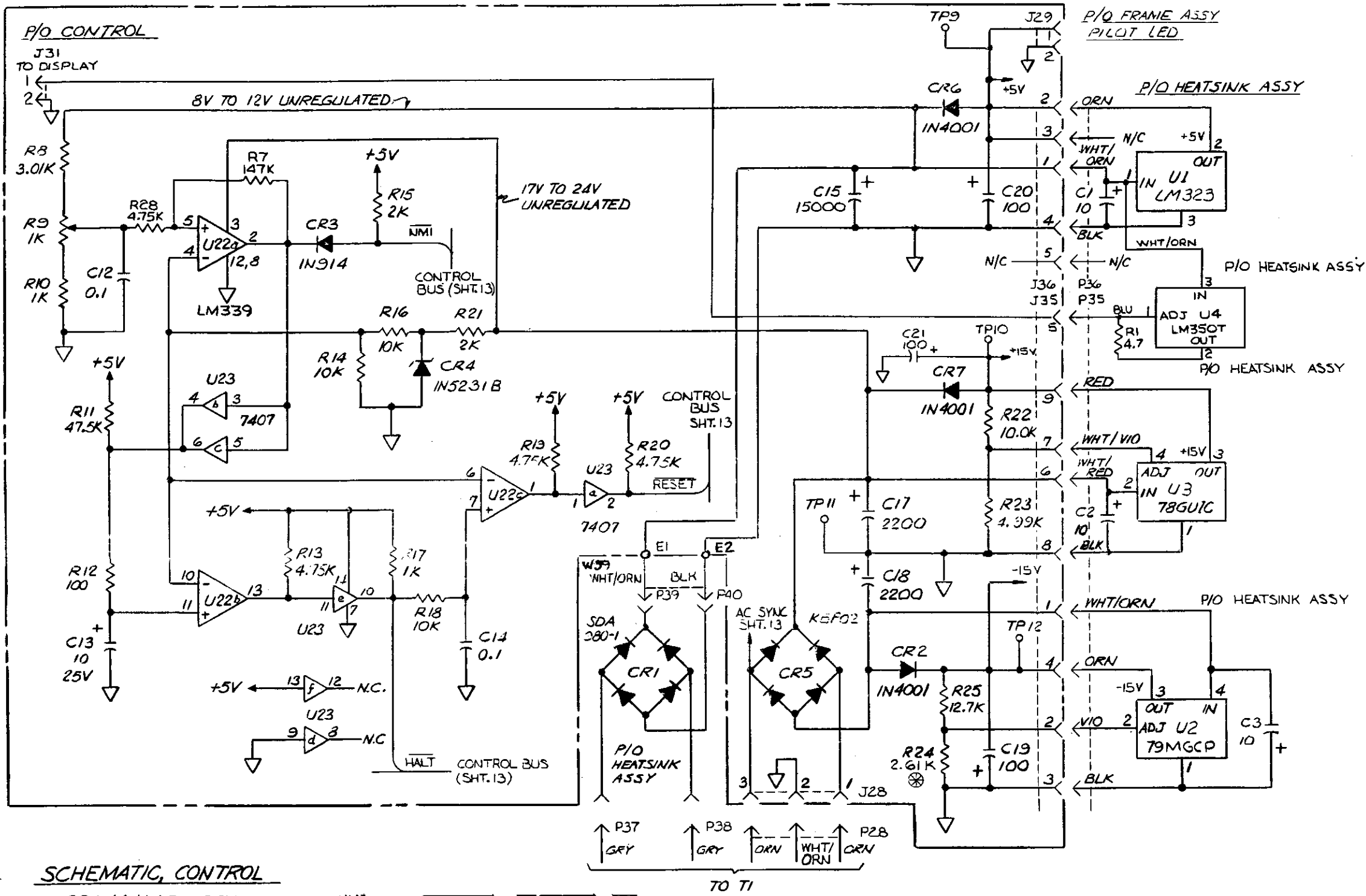

Figure 8-18. Control Component Location



- NOTES:
1. CAPACITANCE VALUES IN  $\mu$ F UNLESS OTHERWISE SPECIFIED
  2. RESISTANCE VALUES IN OHMS.
  3. NUMBERS NOT USED: U31, U28, U9, C3, C16
  4. LAST NUMBERS USED: R40, C33, CR9, U37, J9, TP12
  5.  $\otimes$  IF U2 IS A UA79MGUC THEN R24 IS 2.21K

**SCHEMATIC, CONTROL**  
83146114D REV. H

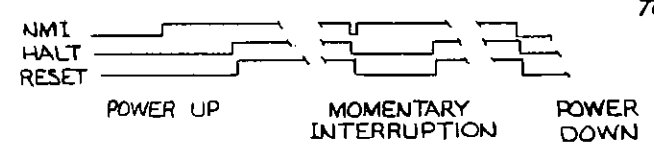

Figure 8-21. Control Schematic, Sh 2 of 3

Section 8  
Schematic Diagrams

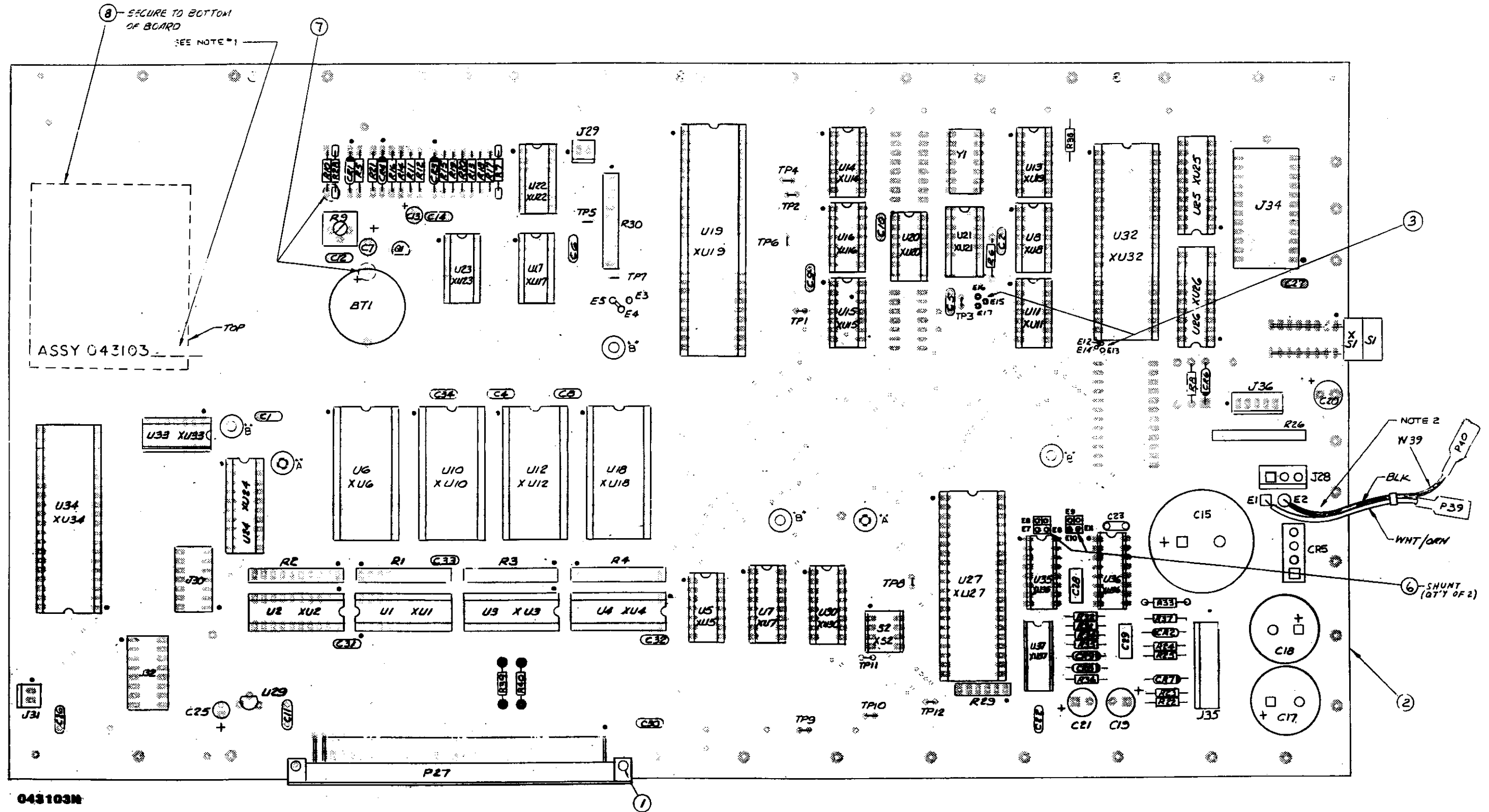
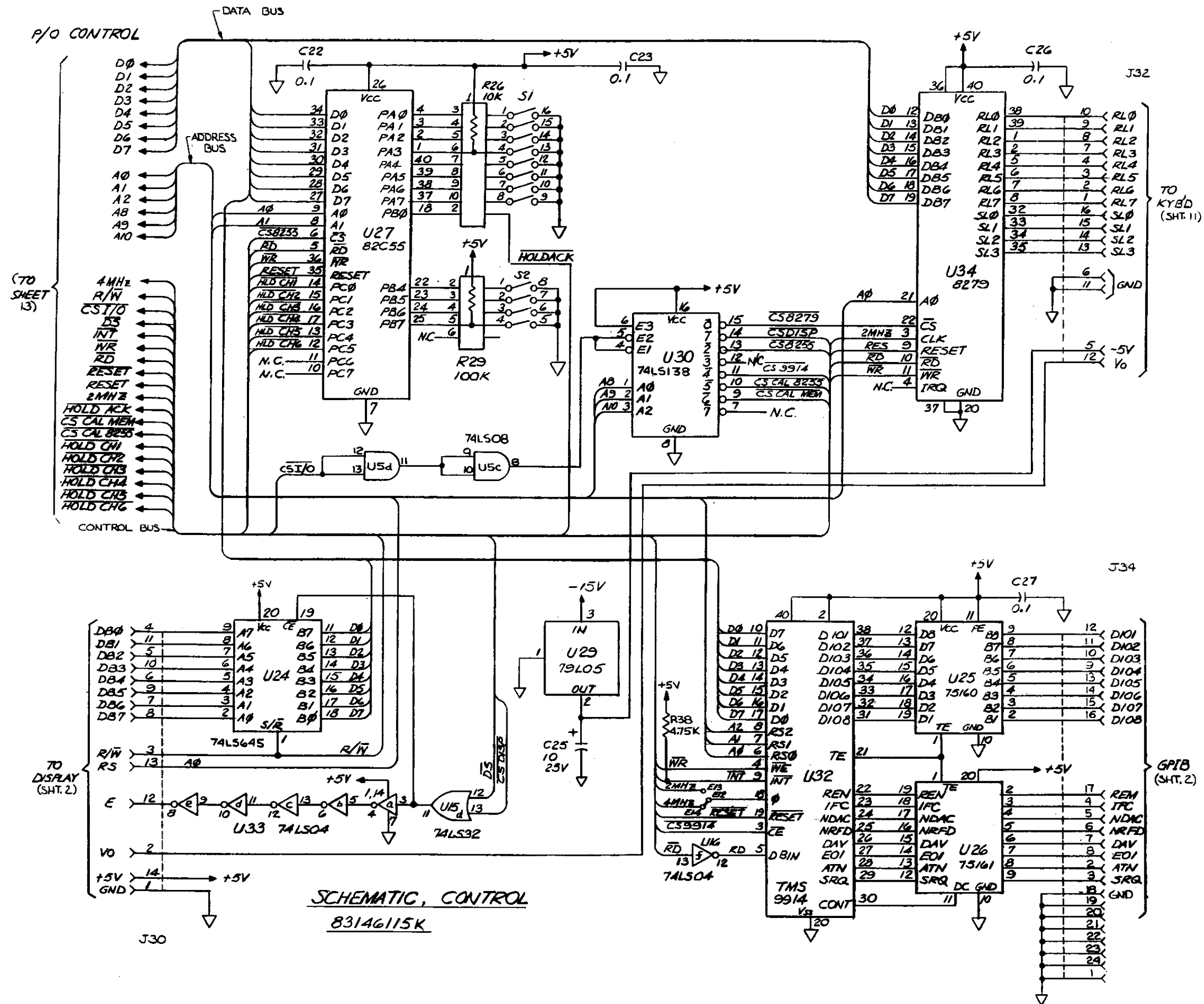

Figure 8-18. Control Component Location



- NOTES:
1. CAPACITANCE VALUES IN  $\mu$ F UNLESS OTHERWISE SPECIFIED.
  2. RESISTANCE VALUES IN OHMS.
  3. NUMBERS NOT USED: U31, U28, U9, C3
  4. LAST NUMBERS USED: R40, C33, CR9 U37, J9, TP12

Figure 8-23. Control Schematic, Sh 3 of 3

# WARRANTY

Boonton Electronics Corporation (BEC) warrants its products to the original Purchaser to be free from defects in material and workmanship for a period of one year from date of shipment for instrument, and for one year from date of shipment for probes, power sensors and accessories. BEC further warrants that its instruments will perform within all current specifications under normal use and service for one year from date of shipment. These warranties do not cover active devices that have given normal service, sealed assemblies which have been opened or any item which has been repaired or altered without BEC's authorization.

BEC's warranties are limited to either the repair or replacement, at BEC's option, of any product found to be defective under the terms of these warranties.

There will be no charge for parts and labor during the warranty period. The Purchaser shall prepay shipping charges to BEC or its designated service facility and shall return the product in its original or an equivalent shipping container. BEC or its designated service facility shall pay shipping charges to return the product to the Purchaser. The Purchaser shall pay all shipping charges, duties and taxes if a product is returned to BEC from outside of the United States.

THE FOREGOING WARRANTIES ARE IN LIEU OF ALL OTHER WARRANTIES, EXPRESSED OR IMPLIED, INCLUDING, BUT NOT LIMITED TO, THE IMPLIED WARRANTIES OF MERCHANTABILITY AND FITNESS FOR A PARTICULAR PURPOSE. BEC shall not be liable to any incidental or consequential damages, as defined in Section 2-715 of the Uniform Commercial Code, in connection with the products covered by the foregoing warranties.

**BOONTON**

---