

8050A

Digital Multimeter

Instruction Manual

P/N 530907

October 1979 Rev 2 7/84

©1984, John Fluke Mfg. Co., Inc. All rights reserved. Litho in U.S.A.



WARRANTY

Notwithstanding any provision of any agreement the following warranty is exclusive:

The JOHN FLUKE MFG. CO., INC., warrants each instrument it manufactures to be free from defects in material and workmanship under normal use and service for the period of 1-year from date of purchase. This warranty extends only to the original purchaser. This warranty shall not apply to fuses, disposable batteries (rechargeable type batteries are warranted for 90-days), or any product or parts which have been subject to misuse, neglect, accident, or abnormal conditions of operations.

In the event of failure of a product covered by this warranty, John Fluke Mfg. Co., Inc., will repair and calibrate an instrument returned to an authorized Service Facility within 1 year of the original purchase; provided the warrantor's examination discloses to its satisfaction that the product was defective. The warrantor may, at its option, replace the product in lieu of repair. With regard to any instrument returned within 1 year of the original purchase, said repairs or replacement will be made without charge. If the failure has been caused by misuse, neglect, accident, or abnormal conditions of operations, repairs will be billed at a nominal cost. In such case, an estimate will be submitted before work is started, if requested.

THE FOREGOING WARRANTY IS IN LIEU OF ALL OTHER WARRANTIES, EXPRESS OR IMPLIED, INCLUDING BUT NOT LIMITED TO ANY IMPLIED WARRANTY OF MERCHANTABILITY, FITNESS, OR ADEQUACY FOR ANY PARTICULAR PURPOSE OR USE. JOHN FLUKE MFG. CO., INC., SHALL NOT BE LIABLE FOR ANY SPECIAL, INCIDENTAL, OR CONSEQUENTIAL DAMAGES, WHETHER IN CONTRACT, TORT, OR OTHERWISE.

If any failure occurs, the following steps should be taken:

1. Notify the JOHN FLUKE MFG. CO., INC., or nearest Service facility, giving full details of the difficulty, and include the model number, type number, and serial number. On receipt of this information, service data, or shipping instructions will be forwarded to you.
2. On receipt of the shipping instructions, forward the instrument, transportation prepaid. Repairs will be made at the Service Facility and the instrument returned, transportation prepaid.

SHIPPING TO MANUFACTURER FOR REPAIR OR ADJUSTMENT

All shipments of JOHN FLUKE MFG. CO., INC., instruments should be made via United Parcel Service or "Best Way"™ prepaid. The instrument should be shipped in the original packing carton; or if it is not available, use any suitable container that is rigid and of adequate size. If a substitute container is used, the instrument should be wrapped in paper and surrounded with at least four inches of excelsior or similar shock-absorbing material.

CLAIM FOR DAMAGE IN SHIPMENT TO ORIGINAL PURCHASER

The instrument should be thoroughly inspected immediately upon original delivery to purchaser. All material in the container should be checked against the enclosed packing list. The manufacturer will not be responsible for shortages against the packing sheet unless notified immediately. If the instrument is damaged in any way, a claim should be filed with the carrier immediately. (To obtain a quotation to repair shipment damage, contact the nearest Fluke Technical Center.) Final claim and negotiations with the carrier must be completed by the customer.

The JOHN FLUKE MFG. CO., INC., will be happy to answer all applications or use questions, which will enhance your use of this instrument. Please address your requests or correspondence to: JOHN FLUKE MFG. CO., INC., P.O. BOX C9090, EVERETT, WASHINGTON 98206, ATTN: Sales Dept. For European Customers: Fluke (Holland) B.V., P.O. Box 5053, 5004 EB, Tilburg, The Netherlands.

*For European customers, Air Freight prepaid.

John Fluke Mfg. Co., Inc., P.O. Box C9090, Everett, Washington 98206

Table of Contents

SECTION	TITLE	PAGE
1	INTRODUCTION AND SPECIFICATIONS	1-1
1-1.	INTRODUCTION	1-1
1-4.	OPTIONS AND ACCESSORIES	1-1
1-5.	SPECIFICATIONS	1-1
2	OPERATION	2-1
2-1.	INTRODUCTION	2-1
2-3.	SETTING UP YOUR INSTRUMENT	2-1
2-4.	Unpacking	2-1
2-8.	AC Line Voltage Requirements	2-1
2-10.	Fuse Replacement	2-1
2-13.	FRONT PANEL FEATURES	2-2
2-15.	Display	2-2
2-18.	SIGNAL INPUT LIMITS	2-2
2-20.	OPERATING TECHNIQUES	2-3
2-22.	AC/DC Voltage (V)	2-3
2-24.	AC/DC Current (mA)	2-3
2-26.	Resistance (Ω)	2-7
2-28.	Conductance ($S = 1\Omega$)	2-7
2-30.	Diode Test	2-7
2-32.	Relative (RELATIVE)	2-7
2-36.	Decibel (dB)	2-11
2-38.	INITIAL CHECKOUT PROCEDURE	2-12
2-41.	APPLICATIONS	2-12
2-43.	DC Voltage Measurement	2-12
2-51.	Current Measurement	2-13
2-56.	Resistance Measurement	2-13
2-62.	Conductance Measurement	2-14
2-80.	Relative Measurement	2-16
2-84.	AC Voltage and Current Measurement	2-16
3	THEORY OF OPERATION	3-1
3-1.	INTRODUCTION	3-1
3-3.	FUNCTIONAL DESCRIPTION	3-1
3-5.	CIRCUIT DESCRIPTION	3-1

TABLE OF CONTENTS, *continued*

SECTION	TITLE	PAGE
3-7.	A/D Converter	3-1
3-18.	Microcomputer	3-2
3-20.	Signal Conditioning	3-6
3-31.	True-RMS Converter	3-8
3-38.	Touch-Hold Circuit	3-8
3-40.	Voltage Protection	3-8
3-43.	Current Protection	3-8
4	MAINTENANCE	4-1
4-1.	INTRODUCTION	4-1
4-4.	SERVICE INFORMATION	4-1
4-7.	GENERAL INFORMATION	4-1
4-9.	Interior Access	4-1
4-24.	dB Reference Impedance Power-Up Setting	4-4
4-26.	Cleaning	4-5
4-28.	PERFORMANCE TESTS	4-5
4-30.	Initial Procedures	4-5
4-32.	Display Test	4-5
4-34.	Linear Voltage Test	4-6
4-36.	dB Voltage Test	4-6
4-38.	Current Test	4-7
4-40.	Resistance and Conductance Tests	4-7
4-42.	CALIBRATION ADJUSTMENTS	4-8
4-44.	DC Calibration	4-8
4-46.	AC Calibration	4-8
4-48.	Jumper Selection	4-8
4-57.	TROUBLESHOOTING	4-12
5	LIST OF REPLACEABLE PARTS	5-1
	TABLE OF CONTENTS	5-1
5-1.	INTRODUCTION	5-2
5-3.	PARTS ORDERING INFORMATION	5-2
6	OPTIONS AND ACCESSORIES	6-1
	TABLE OF CONTENTS	6-1
	INTRODUCTION	6-2
	ACCESSORIES	600-1
	OPTIONS	601-1
7	SCHEMATIC DIAGRAMS	7-1
	TABLE OF CONTENTS	7-1
	APPENDIX A	A-1

List of Tables

TABLE	TITLE	PAGE
1-1.	8050A Accessories	1-2
1-2.	8050A Specifications	1-2
2-1.	8050A Controls, Indicators, and Connectors	2-3
2-2.	Maximum Input Signal Limits	2-5
3-1.	AC Buffer Gains	3-8
4-1.	Required Test Equipment	4-2
4-2.	dB Impedance Selection	4-4
4-3.	Display Test	4-5
4-4.	Linear Voltage Test	4-6
4-5.	dB Voltage Test	4-7
4-6.	Current Test	4-7
4-7.	Resistance and Conductance Tests	4-8
4-8.	DC Calibration	4-10
4-9.	AC Calibration	4-10
4-10.	U5 Jumper Positions	4-11
4-11.	U33 Jumper Positions	4-12
4-12.	Test Points	4-13
4-13.	Troubleshooting Guide	4-14

List of Figures

FIGURE	TITLE	PAGE
Frontispiece	8050A Digital Multimeter	vi
1-1.	8050A Dimensions	1-6
2-1.	Controls, Indicators, and Connectors	2-2
2-2.	Liquid Crystal Display	2-4
2-3.	AC/DC Voltage Operation	2-5
2-4.	AC/DC Current Operation	2-6
2-5.	Resistance Operation	2-7
2-6.	Conductance Operation	2-8
2-7.	Diode Test Operation	2-9
2-8.	Relative Operation	2-10
2-9.	dB Voltage Operation	2-11
2-10.	Circuit Loading Error	2-13
2-11.	Calculating Burden Voltage Error	2-14
2-12.	Transistor Beta Test Fixture	2-15
2-13.	dB Circuit Gain or Loss Measurements	2-17
2-14.	Waveform Comparisons	2-18
2-15.	Crest Factor	2-19
2-16.	Total RMS Value	2-19
2-17.	Measuring Amplifier Bandwidth	2-20
3-1.	8050A Functional Block Diagram	3-3
3-2.	A/D Converter	3-4
3-3.	A/D Converter Waveforms	3-5
3-4.	Microcomputer Simplified Block Diagram	3-6
3-5.	Signal Conditioning	3-7
3-6.	RMS Converter	3-9
4-1.	Display PCB Access	4-3
4-2.	Calibration Adjustment Locations	4-9

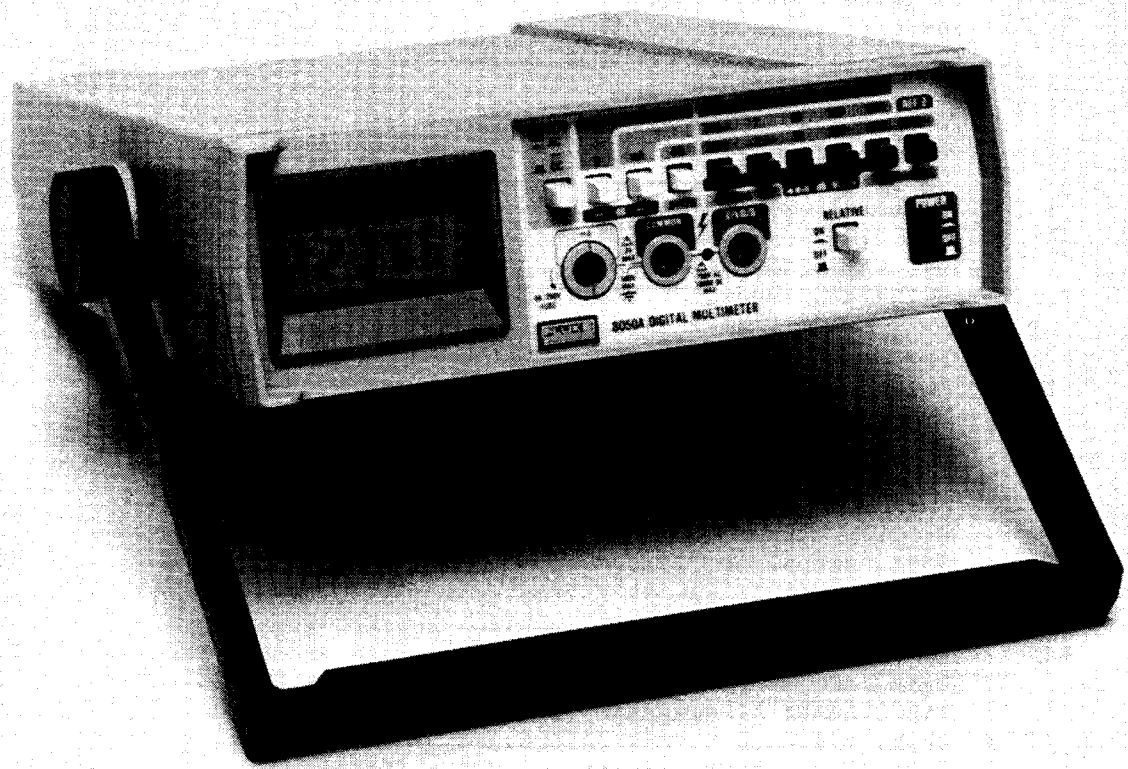

8050A Digital Multimeter

Section 1

Introduction and Specifications

1-1. INTRODUCTION

1-2. Your John Fluke Model 8050A is a portable bench-type digital multimeter (DMM) with a 4-1/2 digit liquid crystal display (LCD). The 8050A has all the following industry-standard features:

- Voltage measurements from 10 μ V to 1000V dc and 10 mV to 750V true-rms ac.
- Current measurements from 10 nA to 2A dc and 10 μ A to 2A true-rms ac.
- Resistance measurements from 10 m Ω to 20M Ω .

The 8050A also has several special measurement features. These special features include the following:

- Conductance measurements up to 100,000 M Ω .
- Voltage measurements in decibels, that can be referenced to 1 of 16 user selected reference impedances.
- Resistance ranges that supply enough voltage to turn on a PN junction to allow diodes and transistors to be tested.
- The ability to store any input signal as an offset or relative reference value.

- Automatic polarity indication and overrange indication.
- Protection from overloads and protection from transients of up to 6 kV, 10 microseconds.
- Dual-slope integration a/d conversion to ensure noise-free measurements.
- Long term calibration stability (1 year).

1-3. The 8050A is warranted for a period of one year upon shipment of the instrument to the original purchaser. Conditions of the warranty are given at the front of this manual. The 8050A is typically powered from ac line voltages but may be powered by the optional rechargeable battery.

1-4. OPTIONS and ACCESSORIES

1-5. The use of the 8050A can be enhanced by the accessories available for this instrument. The accessories are listed in Table 1-1. This instrument can be ordered with the Option 8050A-01 Rechargeable Battery. Detailed information on options and accessories is contained in Section 6 of this manual.

1-6. SPECIFICATIONS

1-7. Specifications for the 8050A are listed in Table 1-2. Specifications for the Option 8050A-01 Rechargeable Battery and other accessory specifications are given in Section 6 of this manual.

**INTRODUCTION
SPECIFICATIONS**

Table 1-1. 8050A Accessories

MODEL	DESCRIPTION	MODEL	DESCRIPTION
C86	Ruggedized Carrying Case	80J-10	Current Shunt
Y8205	Soft Carrying Case	80K-6	High Voltage Probe
M00-200-611	Offset Mounting Kit	80K-40	High Voltage Probe
M00-200-612	Center Mounting Kit	83-RF	RF Probe
M00-200-613	Dual Mounting Kit	85-RF	RF Probe
80T-H	Touch-Hold Probe	Y8100	DC/AC Current Probe
80T-150C	Temperature Probe, Celsius	Y8101	AC Current Transformer
80T-150F	Temperature Probe, Fahrenheit	Y8134	Deluxe Test Lead Set (safety designed)
80I-600	Current Transformer	Y8140	Slim-Flex Test Leads

Table 1-2. 8050A Specifications

ELECTRICAL	The electrical specifications given apply for an operating temperature of 18°C to 28°C (64.4°F to 82.4°F), relative humidity up to 90%, and a 1-year calibration cycle.														
Functions	DC volts, AC volts (linear and dB), DC current, AC current, resistance, diode test, conductance, relative.														
DC Voltage															
	<table border="1"> <thead> <tr> <th>RANGE</th> <th>RESOLUTION</th> <th>ACCURACY for 1-Year</th> </tr> </thead> <tbody> <tr> <td>±200 mV</td> <td>10 μV</td> <td rowspan="5">±(0.03% of reading +2 digits).</td> </tr> <tr> <td>±2V</td> <td>100 μV</td> </tr> <tr> <td>±20V</td> <td>1 mV</td> </tr> <tr> <td>±200V</td> <td>10 mV</td> </tr> <tr> <td>±1000V</td> <td>100 mV</td> </tr> </tbody> </table>	RANGE	RESOLUTION	ACCURACY for 1-Year	±200 mV	10 μV	±(0.03% of reading +2 digits).	±2V	100 μV	±20V	1 mV	±200V	10 mV	±1000V	100 mV
RANGE	RESOLUTION	ACCURACY for 1-Year													
±200 mV	10 μV	±(0.03% of reading +2 digits).													
±2V	100 μV														
±20V	1 mV														
±200V	10 mV														
±1000V	100 mV														
INPUT IMPEDANCE	10 MΩ in parallel with <100 pF, all ranges.														
NORMAL MODE REJECTION RATIO ...	>60 dB at 60 Hz or 50 Hz.														
COMMON MODE REJECTION RATIO ...	>90 dB at dc, 50 Hz or 60 Hz (1 kΩ unbalanced) (>120 dB available on request)														
COMMON MODE VOLTAGE (MAXIMUM)	500V dc or peak ac														
RESPONSE TIME TO RATED ACCURACY	1 second maximum														
MAXIMUM INPUT	1000V dc or peak ac continuous (less than 10 seconds duration on both the 200 mV and 2V ranges).														
*DC voltages can also be measured using the dB mode with .01 dB resolution between 5% of range and full range.															

Table 1-2. 8050A Specifications (cont)

AC Volts (True RMS Responding, AC Coupled)

VOLTAGE READOUT ACCURACY \pm (% of reading + number of digits), between 5% of range and full range.

INPUT VOLTAGE	RESOLUTION	RANGE					
		20 Hz**	45 Hz	1 kHz	10 kHz	20 kHz	50 kHz
10 mV - 200 mV	10 μ V	200 mV					
0.1V - 2V	100 μ V	2V					
1V - 20V	1 mV	20V	1%+10		.5%+10	1%+10	5%+30
10V - 200V	10 mV	200V					
100V - 750V	100 mV	750V				NOT SPECIFIED	

**Typically 3 to 5 digits of rattle will be observed at full scale at 20 Hz.

- RESOLUTION 0.01 dB from 5% of scale to full scale; 0.1 dB from 1-5% of scale, 1 dB below 1% of scale
- VOLT - Hz PRODUCT 10^7 max (200V max @ 50 kHz)
- EXTENDED dB SENSITIVITY Typically -72 dB (600 Ω Ref) \pm 1 dB to 10 kHz
- EXTENDED FREQUENCY RESPONSE .. Typically -3 dB at 200 kHz
- COMMON MODE REJECTION >60 dB at 50 Hz or 60 Hz
RATIO (1 k Ω unbalance)
- CREST FACTOR RANGE Waveforms with a Peak/RMS ratio of 1:1 to 3:1 at full scale, increasing down range
- INPUT IMPEDANCE 10 M Ω in parallel with <100 pF
- MAXIMUM INPUT VOLTAGE 750V rms or 1000V peak continuous (less than 10 seconds duration on both the 200 mV and 2V ranges), not to exceed the volt-hertz product of 10^7
- RESPONSE TIME 2 seconds maximum within a range
- REFERENCE IMPEDANCES Sixteen user-selectable impedance reference levels are provided to reference a 0 dBm, 1 mW level (50 Ω , 75 Ω , 93 Ω , 110 Ω , 125 Ω , 135 Ω , 150 Ω , 250 Ω , 300 Ω , 500 Ω , 600 Ω , 800 Ω , 900 Ω , 1000 Ω , 1200 Ω), and an 8 Ω impedance reference level is provided to reference a 0 dBW level.

NOTE: On request, the NOT SPECIFIED portion of the 100V-750V Range can be extended to the Volt-Hertz product of 10^7 .

dB Ranges

INPUT VOLTAGE	dBm (600 Ω REF)	ACCURACY: from 5% of range to full scale, 1-year					
		RANGE	20 Hz	45 Hz	1kHz	10 kHz	20 kHz
0.77 mV - 2 mV	-60 to -52	200 mV*	0.5 dBm				
2 mV - 2V	-52 to +8	200 mV*					
0.1V - 2V	-18 to +8	2V					
1V - 20V	+2 to +28	20V	\pm 0.25 dBm		\pm 0.15 dBm	\pm 0.25 dBm	\pm 0.75 dBm
10V - 200V	+22 to +48	200V					
100V - 750V	+42 to +60	750V				NOT SPECIFIED	

*When 200 mV range is selected the 8050A autoranges for best accuracy for 2V inputs and less.

**INTRODUCTION
SPECIFICATIONS**

Table 1-2. 8050A Specifications (cont)

DC Current

RANGE	RESOLUTION	ACCURACY for 1-Year	BURDEN VOLTAGE
200 μ A	0.01 μ A	$\pm(0.3\%$ of reading + 2 digits)	0.3V max
2 mA	0.1 μ A		
20 mA	1 μ A		
200 mA	10 μ A		
2000 mA	100 μ A		0.9V max

OVERLOAD PROTECTION (ac/dc) 2A/250V fuse in series with 3A/600V fuse (for high energy sources)

AC Current (True RMS Responding, AC Coupled)

INPUT CURRENT	RESOLUTION	RANGE					BURDEN VOLTAGE
		20 Hz**	45 Hz	2 kHz	10 kHz	20 kHz	
10 μ A - 200 μ A	0.01 μ A	200 μ A					0.3V rms max
100 μ A - 2 mA	0.1 μ A	2 mA					
1 mA - 20 mA	1 μ A	20 mA	2%+10	1%+10	2%+10		
10 mA - 200 mA	10 μ A	200 mA					0.9V rms max
100 mA - 2000 mA	100 μ A	2000 mA				Not specified	

**Typically 3 to 5 digits of rattle will be observed at full scale at 20 Hz.

CREST FACTOR RANGE Waveforms with a Peak/RMS ratio of 1:1 to 3:1 at full scale

Resistance

RANGE	RESOLUTION	ACCURACY for 1-Year	FULL SCALE VOLTAGE ACROSS UNKNOWN RESISTANCE
200 Ω	0.01 Ω	$\pm(0.1\%$ reading + 2 digits + .02 Ω)	.19V
2 k Ω	0.1 Ω		1.2V
20 k Ω	1 Ω	$\pm(.05\%$ of reading + 2 digits)	.2V
200 k Ω	10 Ω		2V
2000 k Ω	100 Ω		.2V
20 M Ω	1 k Ω	$\pm(0.25\%$ reading + 3 digits)	2V

OVERLOAD PROTECTION 500V dc/ac rms on all ranges

OPEN CIRCUIT VOLTAGE Less than 3.5V on all ranges

RESPONSE TIME 10 seconds maximum on 20 M Ω range; 2 seconds maximum on all other ranges
(TO RATED ACCURACY)

DIODE TEST These three ranges have enough voltage to turn on silicon junctions to check for proper forward-to-back resistance. The 2 k Ω range is preferred and is marked with a larger diode symbol on the front panel of the instrument. The three non-diode test ranges will not turn on silicon junctions so in-circuit resistance measurements can be made with these three ranges



Table 1-2. 8050A Specifications (cont)

Conductance

RANGE	RESOLUTION	ACCURACY for 1-Year
2 mS	.1 μ S (10 M Ω)	\pm (0.1% of reading + 5 digits)
200 nS	.01 nS (100,000 M Ω)	\pm (0.5% of reading + 20 digits)

MAXIMUM OPEN CIRCUIT VOLTAGE .. <3.5V

OVERLOAD PROTECTION 500V dc/ac rms on all ranges

CONDUCTANCE UNITS We use the international unit of conductance, the siemen = S = 1/ Ω .
Another unit of conductance is the mho

Relative

RELATIVE REFERENCE An input applied when the RELATIVE button is depressed to the ON position is held as "0" reference point. Subsequent readings indicate the deviation (\pm) from this point. (Note: REL annunciator indicates when this mode is enabled)

RELATIVE ACCURACY Error will not exceed the sum of the errors of the two measurements

ENVIRONMENTAL

Temperature Coefficient <0.1 times the applicable accuracy specification per $^{\circ}$ C for 0 $^{\circ}$ C to 18 $^{\circ}$ C and 28 $^{\circ}$ C to 50 $^{\circ}$ C (32 $^{\circ}$ F to 64.4 $^{\circ}$ F and 82.4 $^{\circ}$ F to 122 $^{\circ}$ F)

Operating Temperature 0 $^{\circ}$ C to 50 $^{\circ}$ C (32 $^{\circ}$ F to 122 $^{\circ}$ F)

Storage Temperature (without batteries): -40 $^{\circ}$ C to +70 $^{\circ}$ C (-40 $^{\circ}$ F to +158 $^{\circ}$ F)
(with batteries): -40 $^{\circ}$ C to +50 $^{\circ}$ C (-40 $^{\circ}$ F to +122 $^{\circ}$ F)

Relative Humidity Up to 90%, 0 $^{\circ}$ C to 35 $^{\circ}$ C (32-95 $^{\circ}$ F), up to 70%, 35 $^{\circ}$ C to 50 $^{\circ}$ C (95-122 $^{\circ}$ F), except on 2000 k Ω , 20 M Ω , and 200 nS ranges where it is up to 80%, 0 $^{\circ}$ C to 35 $^{\circ}$ C (32-95 $^{\circ}$ F)

GENERAL

Maximum Common Mode Voltage 500V dc, or peak ac (low terminal potential with respect to power line ground)

Size 22 cm x 6 cm x 25 cm (8½ in x 2½ x 10 in) see Figure 1-1

Weight 1.08 kg (2 lb 6 oz)

Power Requirements (Line Only Models)

LINE VOLTAGE 90 to 110V ac 47 to 440 Hz
105 to 132V ac, 47 to 440 Hz
200 to 264V ac, 47 to 440 Hz
Factory configured for customer specified voltage

POWER CONSUMPTION 4W max

Standards IEC 348 Protection Class 1

**INTRODUCTION
SPECIFICATIONS**

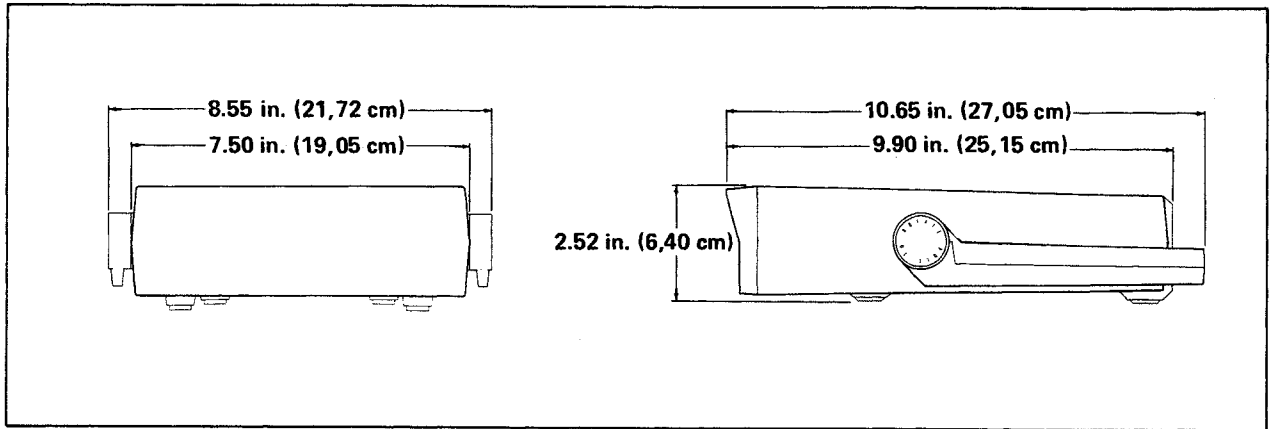

Figure 1-1. 8050A Dimensions

Section 2 Operation

2-1. INTRODUCTION

2-2. This section describes how to set up and make measurements with your 8050A. Even though you may have used a multimeter before, we recommend that you read the entire section carefully so that you can use all of the 8050A features.

2-3. SETTING UP YOUR INSTRUMENT

2-4. Unpacking

2-5. This instrument is shipped in a special protective container that should prevent damage to the 8050A during shipping. Check the shipping order against the contents of the container and report any damage or short shipment to the place of purchase or the nearest Fluke Technical Service Center. A list of these service centers is located in Section 5. The container should include the following:

- The 8050A Multimeter
- Two test leads (one red and one black)
- Line power cord
- The 8050A Instruction Manual

2-6. If reshipment of the instrument is necessary, please use the original shipping container. If the original container is not available, be sure that adequate protection is provided to prevent damage during shipment. We recommend that the instrument be surrounded by at least three inches of shock-absorbing material on all sides of the container.

2-7. Remove the 8050A from the container and place it in a convenient location. To facilitate operation in different locations, the carrying handle on the meter can

be used as a prop-stand or positioned out of the way. To position the handle, pull outward on the hubs of the handle and rotate the handle into position.

2-8. AC Line Voltage Requirements

2-9. AC line voltage requirements for your 8050A are listed on a decal attached to the bottom of the instrument. Refer to Section 4 for the procedure to change the ac line voltage setting.

CAUTION

Do not connect the power cable to the instrument before verifying that the intended source matches the ac line configuration of the instrument.

2-10. Fuse Replacement

2-11. There is one, user replaceable, fuse in the 8050A. The fuse, F1, and the fuse holder form an integral part of the mA input connector and can be removed without special tools. The fuse rating is: 2A, normal blow (recommended part AGX2).

2-12. Use the following procedure to replace the fuse, F1:

1. Set the POWER switch to OFF.
2. Remove the input power cord from the 8050A.

WARNING

DO NOT ATTEMPT TO REPLACE THE FUSE WITH THE INSTRUMENT TURNED ON OR CONNECTED TO LINE POWER.

OPERATION
FRONT PANEL FEATURES

3. Refer to Figure 2-1, item 5 for the location of the fuse holder. The fuse holder is an integral part of the mA input connector.
4. Using a coin or wide blade screwdriver, push in while turning the fuse holder in the direction of the arrow on the front panel decal.
5. Pull out the fuse holder and replace the defective fuse.

2-13. FRONT PANEL FEATURES

2-14. Before using your multimeter, take a few minutes to become familiar with the use of the controls, indicators, and connectors of the 8050A. The front panel features are shown in Figure 2-1 and described in Table 2-1. The features of the Liquid Crystal Display (LCD) are also described in the following paragraph.

2-15. Display

2-16. The features of the Liquid Crystal Display (LCD) are shown in detail in Figure 2-2. The position of the floating decimal point is determined by the range selected (for linear measurements). The maximum measurement value that can be displayed is one count less than the

range selected (e.g., maximum measured voltage that can be displayed in the 200 mV range would be 199.99 mV).

2-17. To extend the life of the LCD and to ensure that the display will be ready to operate, observe the following precautions:

- Do not store or use the instrument in temperatures above or below those specified in Section 1.
- Do not store or use the instrument in humidity above that specified in Section 1.

NOTE

Low temperatures (within the specified operating limits) will cause the LCD response to be sluggish.

- Avoid prolonged exposure of the LCD to direct sunlight (ultraviolet).

2-18. SIGNAL INPUT LIMITS

CAUTION

Exceeding the maximum signal input limits can damage the instrument.

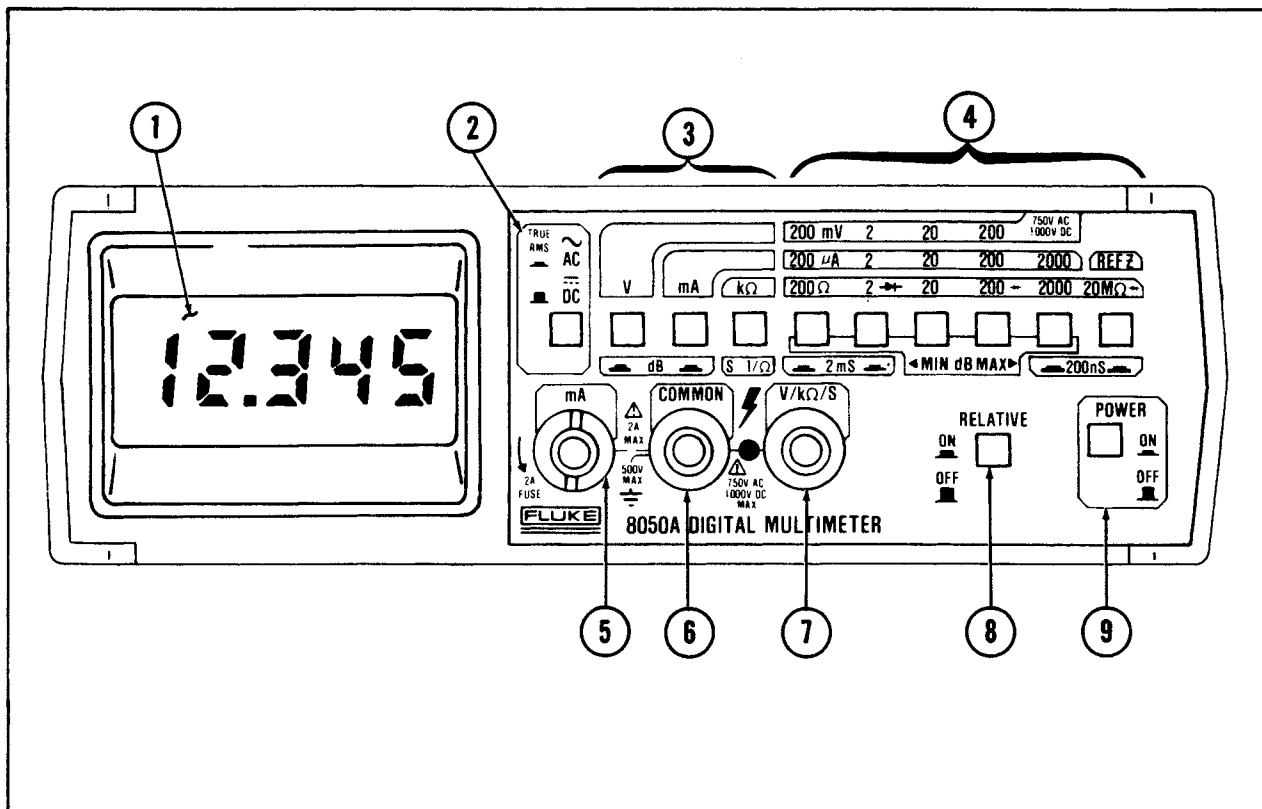

Figure 2-1. Controls, Indicators, and Connectors

Table 2-1. 8050A Controls, Indicators, and Connectors

ITEM NO.	NAME	FUNCTION
1	Display	4½-digit LCD display. Used to indicate measured input values and an overrange condition. Also contains annunciators for high voltage, decibel-display, and relative measurement functions.
2	AC/DC Function Switch	A two-position switch (push IN and push OUT) used to select ac (IN) or dc (OUT) for current or voltage measurements.
3	V/mA/kΩ/dB/S Function Switches	Interlocked switches, used with the AC/DC Function switch to select the measurement functions. Pushing one switch will release the others. The decibel-display function is selected by pushing the V and mA switches simultaneously. The conductance function is selected by pushing the kΩ switch and one of two pairs of Range Function switches.
4	Range Switches	Interlocked switches that select the measurement ranges. Pushing a switch selects the corresponding range and releases a depressed switch(es).
5	mA Input Connector	A fuse protected input connector for current measurements. Fuse is accessible from the front panel.
6	COMMON Input Connector	Test lead connector used as the low or common input for all measurement functions.
7	V/kΩ/S Input Connector	Test lead connector used as the high input for all voltage, resistance, continuity, conductance and decibel measurement functions.
8	RELATIVE Function Switch	Push-on/push-off switch. Used to select the relative function for all measurements.
9	POWER Switch	Push-on/push-off switch. Used for energizing and de-energizing the instrument.

2-19. Before using the 8050A, it is important to note the maximum input limits that may be applied to the instrument. Table 2-2 lists the maximum signal input levels allowed for each function, range, and input connector.

WARNING

TO AVOID ELECTRICAL SHOCK, DO NOT CONNECT THE COMMON INPUT CONNECTOR TO ANY SOURCE MORE THAN 500V DC, OR 500V AC RMS ABOVE EARTH GROUND.

2-20. OPERATING TECHNIQUES

2-21. The following paragraphs describe how to operate the 8050A in each of its seven primary measurement functions. Refer to the Applications paragraphs for additional measurement techniques.

2-22. AC/DC Voltage (V)

2-23. Figure 2-3 describes how to operate the 8050A for ac or dc voltage measurements. For all measurements, select the highest range that will provide the required resolution of the measurement. If measuring an unknown voltage, set the DMM on the highest range, then (if needed) select a lower range.

2-24. AC/DC Current (mA)

2-25. Figure 2-4 describes how to operate the 8050A for ac or dc current measurements. Turn off power to the circuit being measured before breaking the circuit and connecting the 8050A in series with the current source. To minimize common mode voltages, break the circuit on the ground side of the current source. The mA input connector contains an in-line fuse. If the DMM does not respond when measuring current, check the fuse (refer to the fuse replacement procedure in this section). If measuring an unknown current, set the DMM on the highest range, then (if needed) select a lower range.

OPERATION
LCD DISPLAY

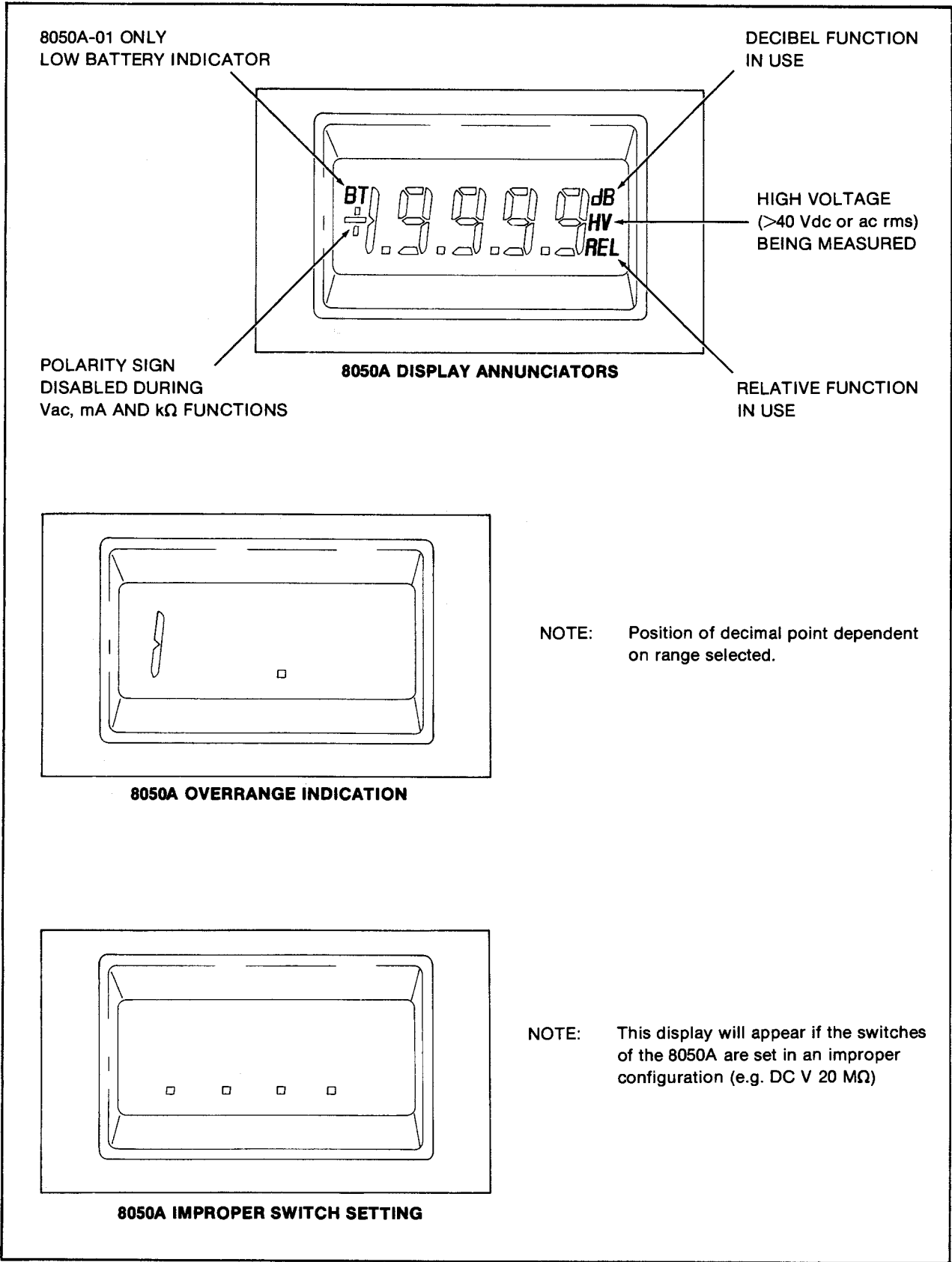

Figure 2-2. Liquid Crystal Display

Table 2-2. Maximum Input Signal Limits

FUNCTION SELECTED		RANGE SELECTED	INPUT TERMINALS	MAXIMUM INPUT OVERLOAD
V or dB	DC	ALL RANGES	V/kΩ/S and COMMON	1000V dc or peak ac
	AC	20V, 200V, 750V		750V rms continuous or 10 ⁷ V·Hz
		2V, 200 mV		750V rms for no longer than 15 seconds or 10 ⁷ V·Hz
mA	DC or AC	ALL RANGES	mA and COMMON	Double fuse protected: 2A, 250V fuse in series with a 3A, 600V fuse
kΩ or S		ALL RANGES	V/kΩ/S and COMMON	500V dc or ac rms

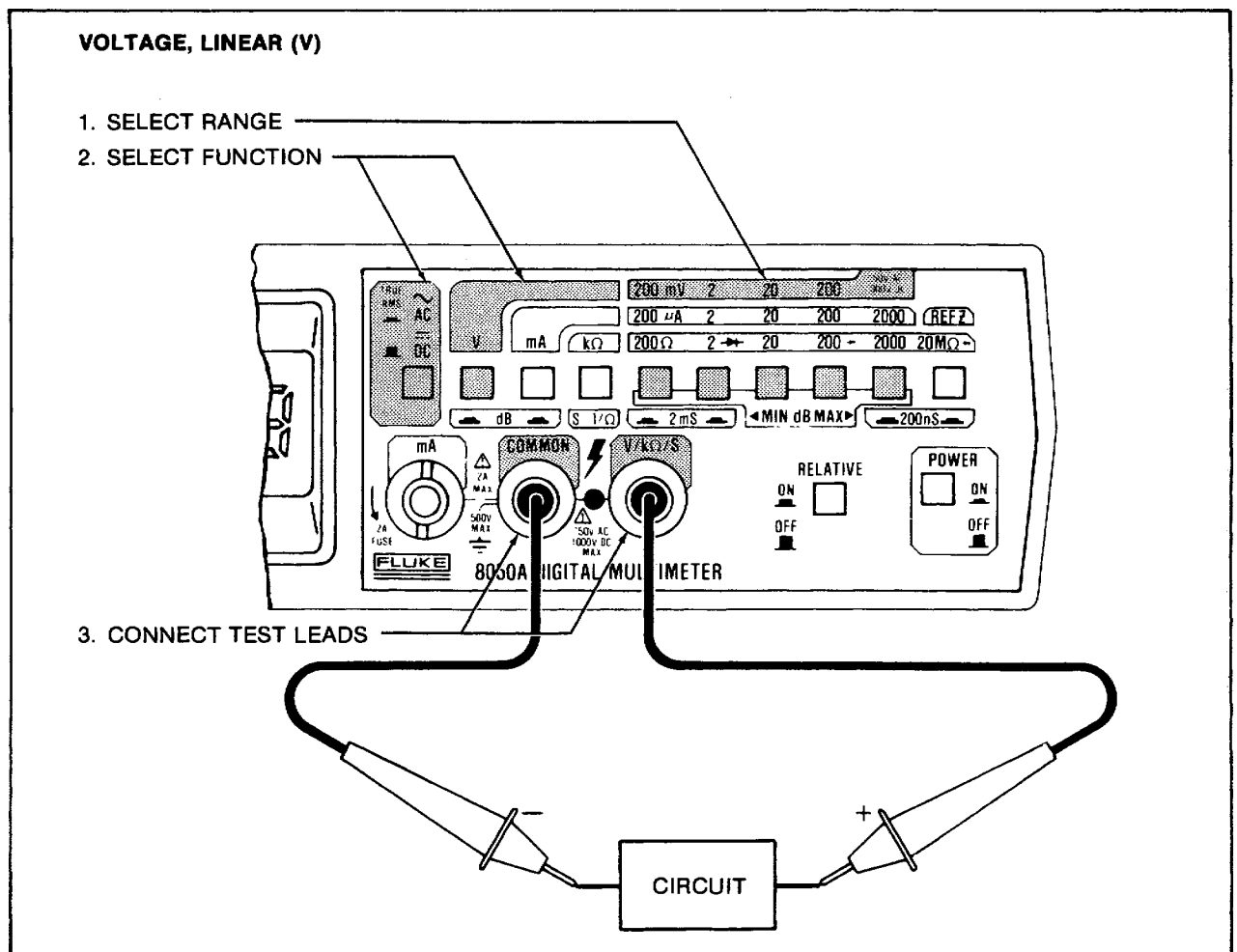
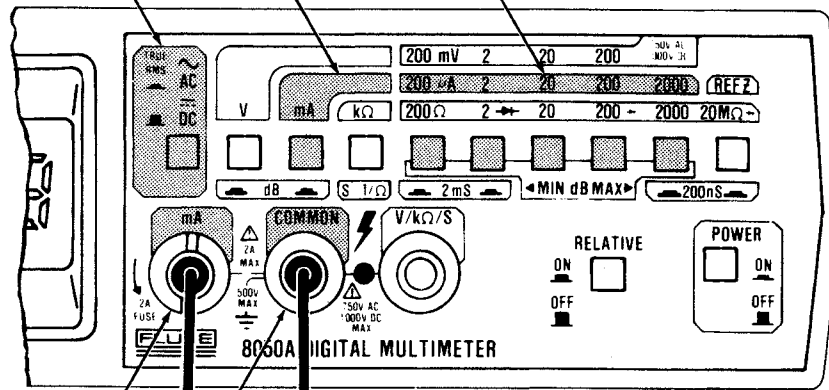

Figure 2-3. AC/DC Voltage Operation

OPERATION
AC/DC VOLTAGE

CURRENT (mA)

- 1. SELECT RANGE
- 2. SELECT FUNCTION



- 3. CONNECT TEST LEADS

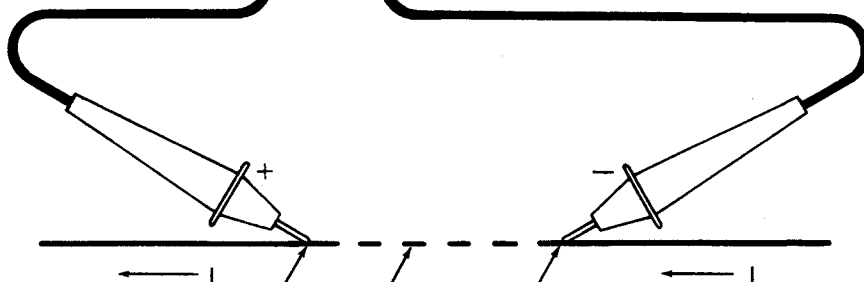

- 4. BREAKCIRCUIT
- 5. PLACE 8050A m SERIES

Figure 2-4. AC/DC Current Operation

2-26. Resistance (Ω)

2-27. Figure 2-5 describes how to operate the 8050A for resistance measurements. When $k\Omega$ is selected, erroneous measurements can occur if power is present in the resistance being measured. Ensure that power is removed before measuring in-circuit resistances. The AC/DC function switch has no effect during resistance measurements.

2-28. Conductance ($S=1/\Omega$)

2-29. Figure 2-6 describes how to operate the 8050A for conductance measurements. When $S=1/\Omega$ is selected, two ranges of measurements are available, 2 mS and 200 nS. To select either range, press both range switches (above the grey-shaded area) simultaneously.

2-30. Diode Test

2-31. Figure 2-7 describes how to operate the 8050A for diode tests. The three resistance ranges with the diode symbol beside the range value provide a measurement

voltage sufficient to cause a silicon junction to conduct. These ranges (2 $k\Omega$, 200 $k\Omega$ and 20 $M\Omega$) can be used to check silicon diodes and transistors. The 2 $k\Omega$ resistance range is the preferred diode and transistor testing range and is labeled with the largest diode symbol ($\rightarrow|$). For a silicon diode, the typical forward bias voltage (on the 2 $k\Omega$ $\rightarrow|$ range) is 0.6V. A reversed bias silicon diode should display the overrange indicator (on the 2 $k\Omega$ $\rightarrow|$ range).

2-32. Relative (RELATIVE)

2-33. Figure 2-8 describes how to operate the 8050A for relative measurements. The relative function stores a reading as an offset or relative reference value. When the RELATIVE switch is set to ON during a measurement, the value of that measurement is stored, and the REL (relative reference) annunciator appears to the right of the zeroed display. Subsequent measurements (in the same function and range) are displayed as the difference between the measured value and the stored relative reference.

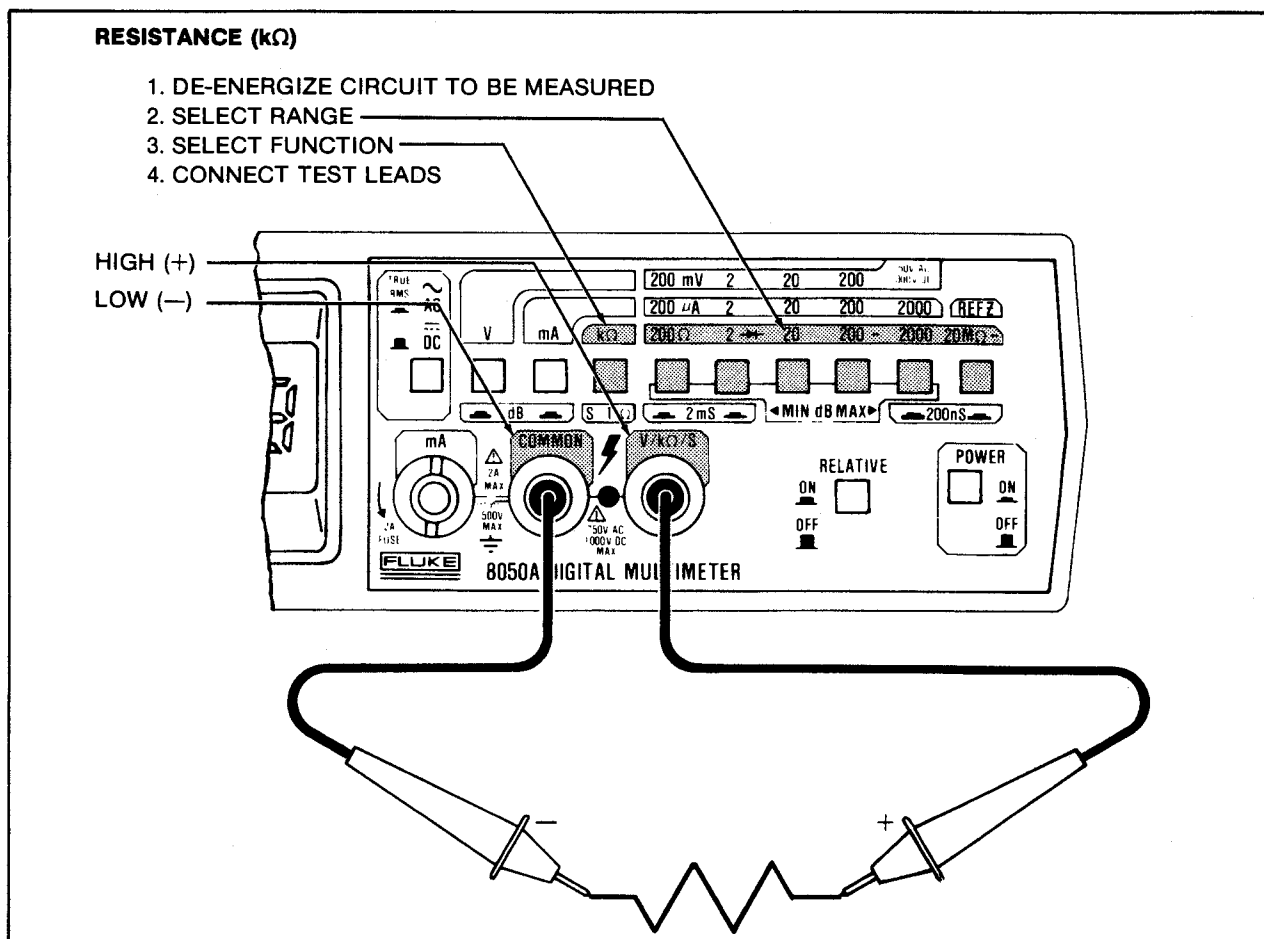
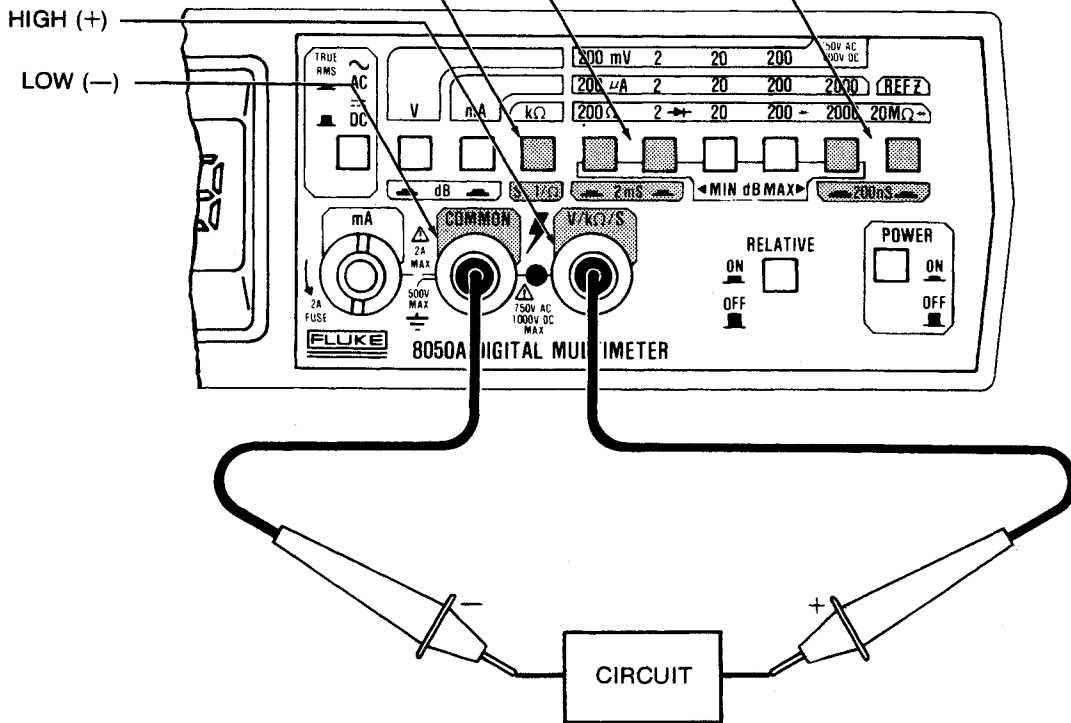

Figure 2-5. Resistance Operation

**OPERATION
CONDUCTANCE**

CONDUCTANCE ($S = 1/\Omega$)

1. DE-ENERGIZE CIRCUIT TO BE MEASURED
2. SELECT RANGE
3. SELECT FUNCTION
4. CONNECT TEST LEADS



NOTE: Zero the display (with the RELATIVE function) taking conductance measurements (see Relative Measurements).

Figure 2-6. Conductance Operation

2-34. Refer to the sample displays in Figure 2-8. If the range changes, the 8050A automatically multiplies or divides the relative reference by the appropriate power of ten before subtracting the relative reference from the measurement. If the function is changed, the REL annunciator disappears, and the relative reference is stored with the original function. When the original function is reselected, the relative reference is restored (and the REL annunciator appears) unless a new relative reference was selected. Setting the RELATIVE switch to OFF or turning the instrument off cancels the original relative reference.

2-35. The relative function may be used with all measurement functions: ac or dc voltage, ac or dc current,

ac or dc dB, resistance, and conductance. Note that input overload limits are not changed by the use of the relative function. Also, when using the relative reference function, the display limits do not change. The possible readings are still subject to the limits of the 19999 counts of the a/d converter, regardless of the relative reference. For example, if a dc voltage measurement of +15.000V is made on the 20V range and stored as a relative reference, the maximum positive relative voltage that could be displayed without overranging is +4.999V (+19.999V input). The maximum negative input voltage that could be measured without overranging is -4.999V, which would cause the relative display reading to be -19.999V REL.

DIODE TEST (k Ω , \rightarrow)

1. DE-ENERGIZE CIRCUIT TO BE MEASURED
2. SELECT Range (2 \rightarrow range preferred)
3. SELECT FUNCTION
4. CONNECT TEST LEADS

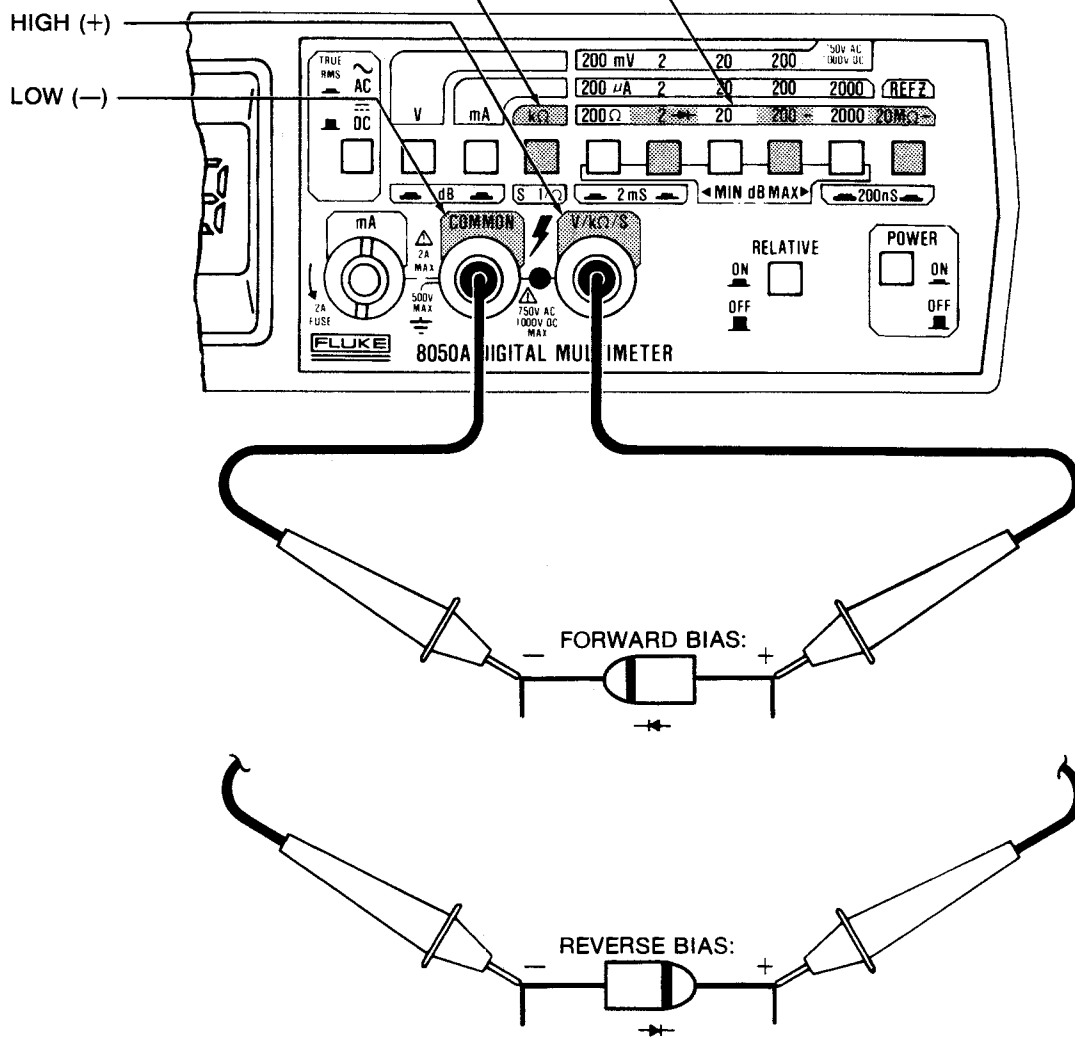
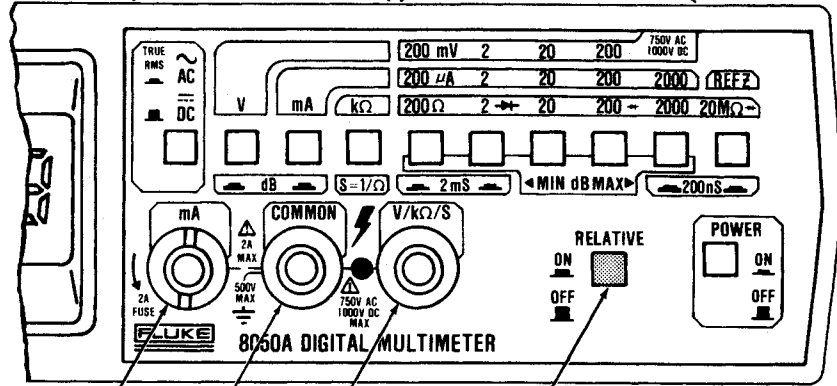

Figure 2-7. Diode Test Operation

**OPERATION
RELATIVE**

RELATIVE (RELATIVE)

1. Select range and function (use any measurement range and function).



2. Connect test leads and take the desired measurement to be used as the relative reference. While taking the relative reference measurement, set the RELATIVE switch to ON. This will store the value as the relative reference.

Measuring the relative reference

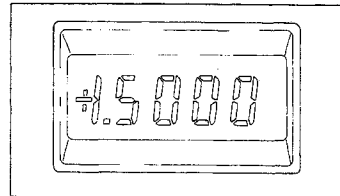

INPUT
1.5V dc

3. Subsequent measurements will be displayed as the difference between the relative reference and measurement. See insert.

Storing the relative reference

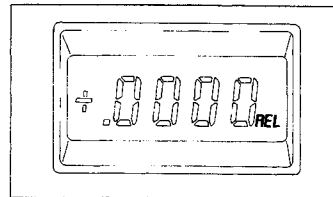

Subsequent measurement of 1.9V dc

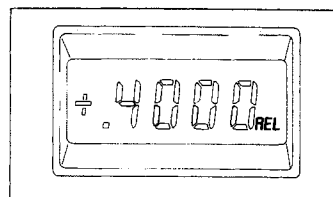

INPUT
1.9V dc

4. To cancel the relative function, set the RELATIVE switch to OUT.

Figure 2-8. Relative Operation

2-36. Decibel (dB)

2-37. Figure 2-9 describes how to operate the 8050A for voltages in decibels. When dB is selected, the 8050A converts ac or dc voltage readings into the dBm equivalent (decibels above or below one milliwatt). The reference impedance for decibel measurements is selected

from 16 stored reference impedances. The 8050A is setup at the factory to turn on with a default reference impedance of 600Ω. The power-up default reference impedance may be changed to any of the 16 stored impedances. (Refer to Section 4 for information on how to change the default setting.)

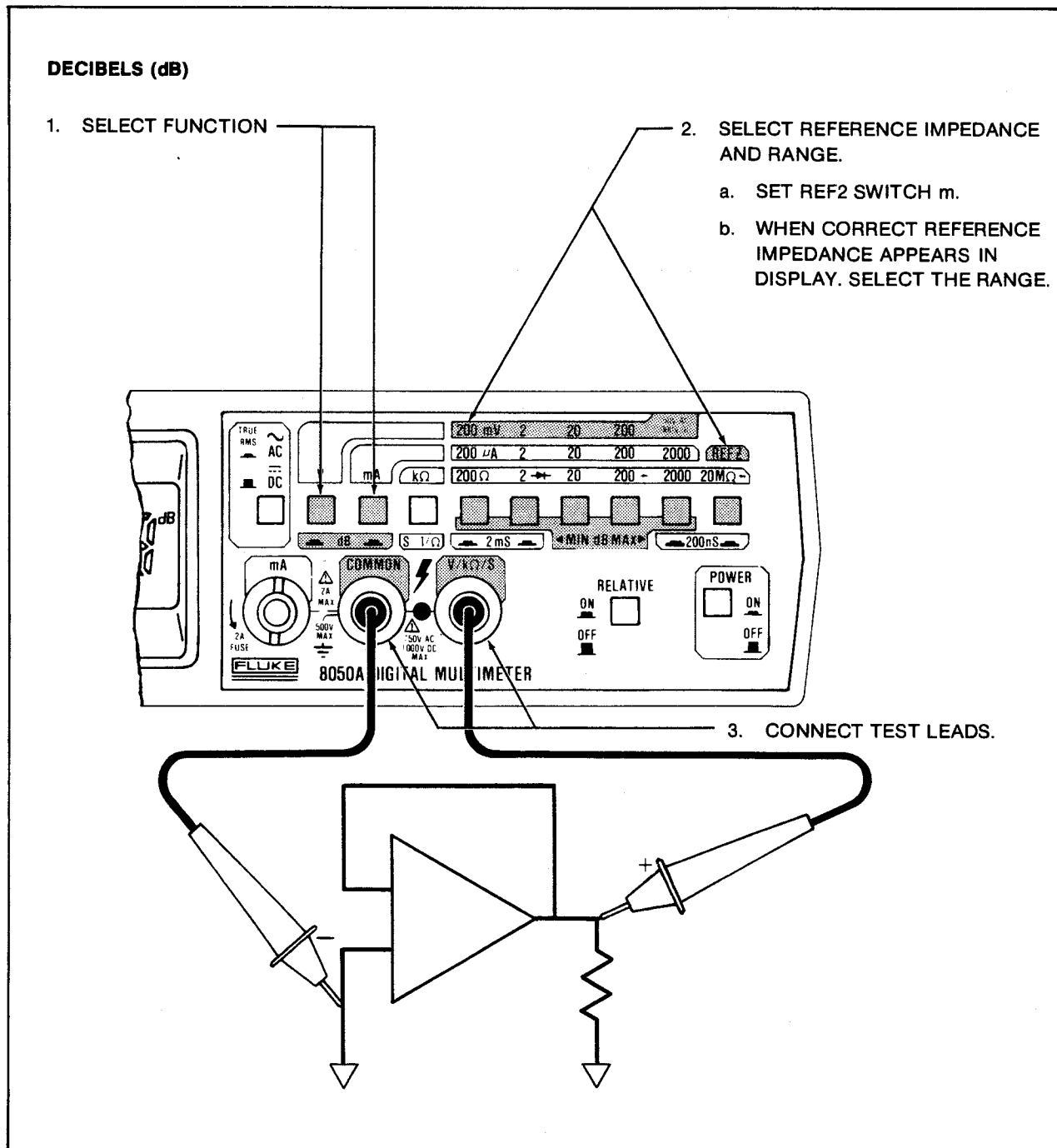

Figure 2-9. dB Voltage Operation

OPERATION

INITIAL CHECKOUT PROCEDURE

2-38. INITIAL CHECKOUT PROCEDURE

2-39. The following procedure allows the operator to verify that the 8050A is operating correctly for most functions. The only test equipment required is a set of test leads and access to a standard wall socket. This procedure checks for general operation only and is not intended to verify instrument accuracy. Performance tests and calibration adjustments are contained in Section 4 of this manual for the purpose of testing instrument accuracy.

2-40. Use the following procedure to verify that most of the functions of the 8050A are operating correctly:

1. Select the AC V function on the 8050A.
2. Set the instrument to the 750V range.

WARNING

THE LOCAL LINE VOLTAGE IS BEING MEASURED IN THE FOLLOWING STEP. DO NOT TOUCH THE PROBE TIPS OR ALLOW THE PROBE TIPS TO COME IN CONTACT WITH EACH OTHER WHILE PERFORMING THE FOLLOWING STEP.

3. Insert the probe tips into a standard wall socket. Note the preceding warning. The display should read the local line voltage. The HV annunciator should be displayed to the right of the voltage reading.
4. Momentarily set the instrument to the 20V range. The overrange indicator should be displayed.
5. Set the instrument to the 750V range.
6. Set the RELATIVE switch to ON. The display should read +000.0 (the display will zero momentarily and will then display the relative voltage of the line fluctuations) and the REL annunciator appears.
7. Remove the test leads from the wall socket.
8. Set the RELATIVE switch to OFF.
9. Select the resistance function. The overrange indicator should appear in the display.
10. Set the instrument to the 200 Ω range and short the test leads. The display should read 00.00.
11. Select the $S=1/\Omega$ (conductance) function, 2 mS range. The display should read .0000 \pm 5 counts.

12. Short the test leads. The overrange indicator should appear in the display.
13. Select the dB function, then push the REF Z (right-most range switch). The turn-on dB reference value (nominally 600) should appear on the display for approximately three seconds, followed by the other 15 stored dB reference impedances sequencing through at a 1/second rate.
14. Push one of the other range switches, noting the value of the reference impedance, wait a few seconds, then push the REF Z switch again. The value that appeared when the range switches were changed should appear for 3 seconds followed by the sequence of the other reference impedances.
15. This concludes the Initial Checkout procedure for the 8050A. If the performance of the instrument is in question refer to the Performance tests in Section 4 of this manual.

2-41. APPLICATIONS

2-42. The following paragraphs contain information on and measurement techniques that expand the use of the seven primary functions of the 8050A. These applications are arranged by the measurement type.

2-43. DC Voltage Measurement

2-44. The following paragraphs contain additional information on and measurement techniques for dc voltage measurements.

2-45. REFERENCING DBM TO CIRCUIT IMPEDANCES

2-46. The 8050A provides 16 commonly used circuit impedances to use as a reference impedance when making dBm measurements. However, this does not cover all circuit impedances. There are two procedures for referencing dBm measurements to other circuit impedances. The first one requires an ac or dc voltage standard. The second procedure is actually a correction factor that can be used if a voltage standard is not available.

2-47. Use the following procedure to reference dBm measurements to impedances that are not provided by the 8050A:

1. Use the following formula to convert the circuit impedance into a reference level:

$$\text{Reference Level} = \sqrt{0.001 \times \text{circuit impedance}}$$

2. Connect the 8050A to the Voltage Standard as follows: V/kΩ/S input connector to the Voltage Standard Hi output, COMMON input connector to the Voltage Standard low output.
3. Select the V function (either ac or dc, depending upon the Voltage Standard used).
4. Adjust the Voltage Standard to output the reference level calculated in step 1. This value should appear in the 8050A display.
5. Select the dB function.
6. Set the RELATIVE switch to ON. Decibel measurements will now be referenced to the circuit impedance.

2-48. Use the following procedure to obtain a correction factor for referencing dB to other circuit impedances without the use of a Voltage Standard:

1. Select the REF Z that is closest to the impedance of the circuit to be measured.
2. Calculate the reference impedance correction factor using the following equation.

$$10 \log \frac{\text{Circuit Impedance}}{\text{REF Z}} = \text{Correction Factor}$$

3. Add the correction factor to the measured value.

2-49. **CIRCUIT LOADING ERROR (VOLTAGE)**

2-50. Circuit loading errors occur when voltage measurements are taken on high impedance circuits. This is because the DMM loads the source, thus changing the operating voltage of the source. As long as the circuit impedance (source impedance) is low compared to the input impedance of the DMM this error may be insignificant. For example, when measuring a circuit with a source impedance of 1 kΩ or less, the error will be ≤.01 %. If the circuit loading error is significant, use the appropriate formula contained in Figure 2-10 to calculate the percentage of error.

2-51. Current Measurement

2-52. The following paragraphs contain additional information on and measurement techniques for current measurements.

WARNING

OPERATOR INJURY AND INSTRUMENT DAMAGE MAY RESULT IF THE BACKUP FUSE (F2) BLOWS WHEN CURRENT IS BEING MEASURED FROM A VOLTAGE OF GREATER THAN 600 VOLTS.

2-53. **BURDEN VOLTAGE ERROR**

2-54. When a multimeter is placed in series with a circuit to measure current, the voltage drop of the multimeter induces an error. This error is called the burden voltage. The maximum full-scale burden voltages for the 8050A are 0.3V for the four lowest ranges and 0.9V for the highest range.

2-55. These voltage drops can affect the accuracy of the current measurement if the current source is unregulated and the resistance of the shunt and fuses of the multimeter exceeds 1/1000 of the source resistance. If the multimeter burden voltage is significant, the formula in Figure 2-11 can be used to calculate the burden voltage error.

2-56. Resistance Measurement

2-57. The following paragraphs contain additional information on and measurement techniques for resistance measurements.

1. **DC VOLTAGE MEASUREMENTS**

Loading Error in % = $100 \times R_s \div (R_s + 10^7)$
Where: R_s = Source resistance in ohms of circuit being measured.

2. **AC VOLTAGE MEASUREMENTS**

First, determine input impedance, as follows: *

$$Z_{in} = \frac{10^7}{\sqrt{1 + (2 \pi F \cdot R_{in} \cdot C_{in})^2}}$$

Where: Z_{in} = effective input impedance
 $R_{in} = 10^7$ ohms
 $C_{in} = 100 \times 10^{-12}$ Farads
 F = frequency in Hz

Then, determine source loading error as follows: *

Loading Error in % = $100 \times \frac{Z_s}{Z_s + Z_{in}}$

Where: Z_s = source impedance
 Z_{in} = input impedance (calculated)

*Vector algebra required

Figure 2-10. Circuit Loading Error

OPERATION RESISTANCE MEASUREMENT

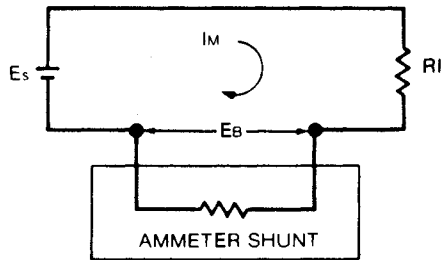

E_s = Source voltage
 R_I = Load resistance + Source resistance
 I_m = Measured current (display reading in amps)
 E_b = Burden voltage (calculated)
 E_b = meas. current $\{ (200/\text{current range in mA}) + .35 \}$

ERROR:

Error in % = $100 \times E_b / (E_s - E_b)$
 Error in A = $(E_b \times I_m) / (E_s - E_b)$

EXAMPLE:

$E_s = 15\text{V}$
 $R_I = 100\text{ k}\Omega$
 $I_m = 148.51\ \mu\text{A} (.14851\text{ mA})$

$E_b = 148.51 \times 10^{-6} \times \{ (200/.2) + .35 \}$
 $= 148.51 \times 10^{-6} \times 1000.35 = 148.56\text{ mV}$

Max. error in % = $100 \times [148.56\text{ mV} / (15\text{V} - .14856\text{V})] = 1.0003\%$

Add this to the range spec. accuracy:

Max. error in % = $1.0003\% \pm (.2\% + 2\text{ digits})$

Max. error in A = $(148.56\text{ mV} \times 148.51\ \mu\text{A}) / (15000\text{ mV} - 148.56\text{ mV})$
 $= 1.486\ \mu\text{A}$

Add 1.486 μA to the reading for correct current

Figure 2-11. Calculating Burden Voltage Error

2-58. TEST LEAD COMPENSATION

2-59. When measuring low resistances (less than 200 Ω) the effect of test lead resistance may add a significant error. This error may be compensated for by using the relative function of the 8050A. Use the following procedure to compensate for test lead resistance.

1. Setup the 8050A as shown in Figure 2-5, steps 1 through 3.
2. Short the test leads together (press the test leads together firmly) and set the RELATIVE switch to ON.
3. Disengage the test leads and proceed with low-level resistance measurements. The resistance of the test leads will be subtracted from the readings of subsequent measurements.

2-60. RESISTANCE COMPARISONS

2-61. When one resistance value is needed for several measurements (e.g. sorting resistors to find a matched pair) the relative function of the 8050A can be used to simplify the process. The following procedure is an example of how the relative function may be used to match resistors:

1. Select the k Ω function on the 8050A.
2. Select an appropriate range for the resistance being matched.
3. Measure the resistor.

4. With the resistor value still displayed, set the RELATIVE switch to ON.
5. Measure the other resistors. Choose the resistor with the least deviation from the resistor first measured.

2-62. Conductance Measurement

2-63. The following paragraphs contain additional information on and measurement techniques for conductance measurements.

2-64. HIGH RESISTANCE MEASUREMENTS

2-65. The conductance function of the 8050A can be used to measure high resistive (low leakage) components (diodes and capacitors) while minimizing noise problems. The two conductance ranges, 2 mS and 200 nS, can be used for making resistance measurements from 500 Ω to 10 M Ω and 5 M Ω to 100,000 M Ω .

2-66. LEAKAGE RESISTANCE MEASUREMENTS

2-67. Use the standard conductance function for leakage testing on purely resistive components (e.g., cables and pcb's). Remember to zero the display reading with the relative function before taking conductance measurements.

NOTE

Under high humidity conditions, finger prints and other residual surface contaminants can create their own leakage paths. Use clean test leads to minimize the effect of leakage paths.

2-68. DIODE LEAKAGE TESTS

2-69. Diode leakage (I_R) tests require that the diode junction be reverse biased while being measured. Connect the anode of the diode to the COMMON input connector to reverse bias a diode junction. A good silicon diode will produce an in-scale display reading on the 200 nS range when reverse biased.

2-70. TRANSISTOR TESTER

2-71. The transistor tester described in the following paragraphs provides approximate test information. Beta is tested using a V_{CE} of 2V and an I_C of about 200 μA . This transistor tester is useful for checking the proper operation of transistors and approximate beta values for comparative measurements.

2-72. The transistor tester fixture is described in Figure 2-12. When assembled and connected to the V/k Ω /S and the COMMON input connector, the 8050A can be used to determine the following information about transistors:

- Transistor type (NPN or PNP)

- Defective transistors (shorted or open)
- Collector-to-emitter leakage (I_{CES})
- Beta from 10 to 1000 in a single range.

2-73. Transistor type is determined by setting the switch on the tester fixture to BETA, setting the 8050A to the 2 mS range, and observing the display reading. If a low reading (< 0.0100) is displayed, reverse the test fixture at the input connectors. If the collector of the transistor is now connected to the COMMON input connector the transistor is a PNP type. An NPN type will have its collector connected to the V/k Ω /S input connector.

2-74. Defective Transistors

2-75. If the transistor is defective, the following indications will appear, regardless of transistor type or test position:

1. An open transistor will produce a display reading of 0.0005 or less.

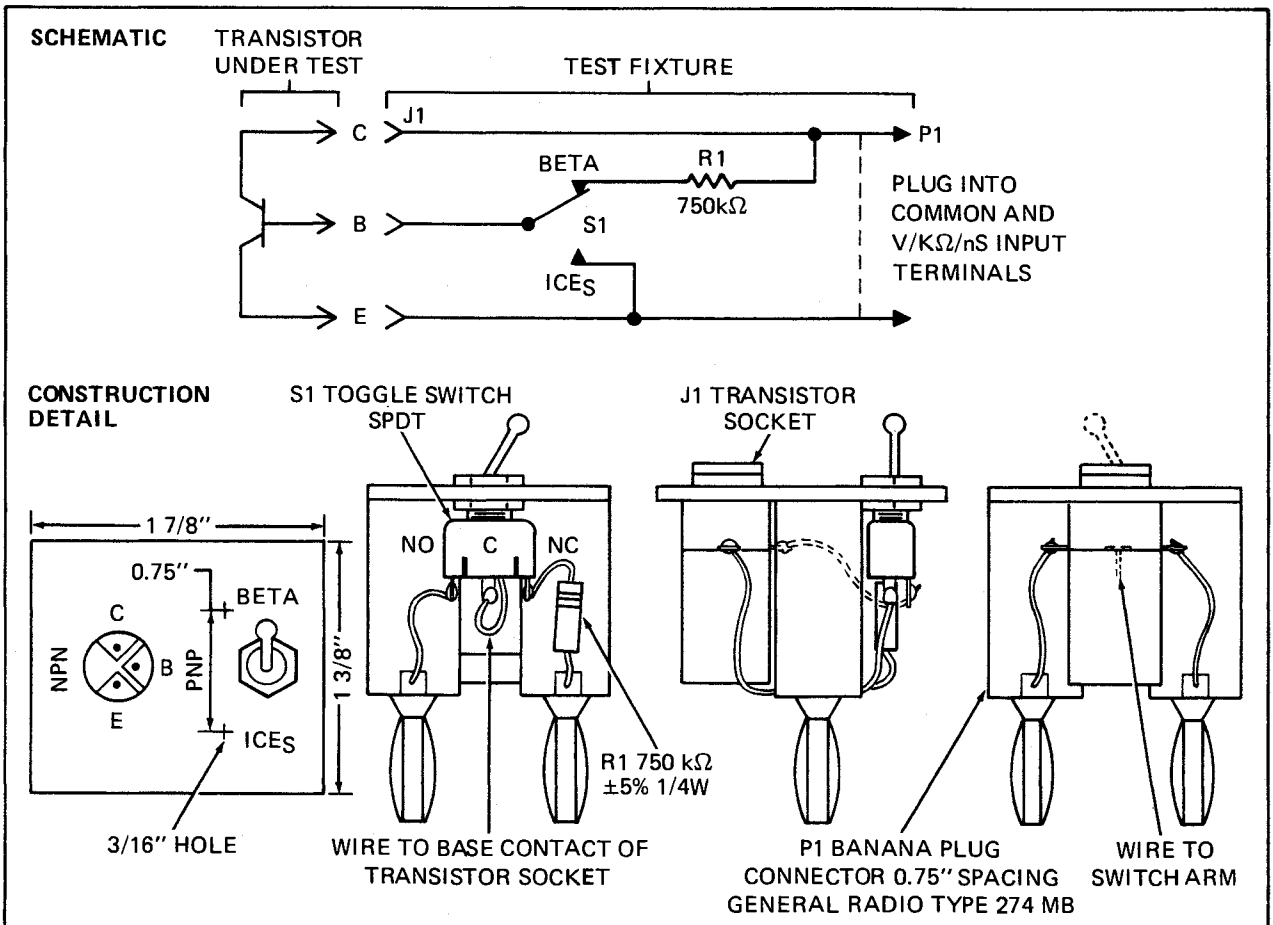

Figure 2-12. Transistor Beta Test Fixture

2. A shorted transistor will produce an overrange indication on the display.

2-76. Transistor Leakage Test

2-77. Use the following procedure to test transistors for leakage (ICES):

1. Install the transistor, and connect the test fixture to the 8050A (see preceding paragraphs).
2. Set the switch on the test fixture to ICES.
3. Select the conductance function, 2 mS range on the 8050A.
4. A reading of more than 0.0020 (6 μ A) indicates a faulty transistor (silicon).

2-78. Transistor Beta Test

2-79. Use the following procedure to test the beta of a transistor:

1. Install the transistor and connect the test fixture to the 8050A (see preceding paragraphs).
2. Set the switch in the test fixture to BETA.
3. Select the conductance function, 2 mS range on the 8050A.
4. Note the display reading on the 8050A, then shift the decimal point three places to the right. This will be the beta of the transistor.

NOTE

Beta is a temperature-sensitive measurement. Allow sufficient time for each tested transistor to stabilize. Avoid touching the transistor case with your fingers while making beta measurements.

2-80. Relative Measurement

2-81. The following paragraphs contain additional information on and measurement techniques for relative measurements.

2-82. DECIBEL (dB) CIRCUIT GAIN OR LOSS

2-83. The relative function of the 8050A makes it easy to determine the gain or loss (in decibels) of a circuit. By using the relative function, any voltage level can be used as the 0 dB reference point for dB measurements. Figure 2-13 describes how to use the relative function to measure circuit gain or loss in dBs.

2-84. AC Voltage and Current Measurement

2-85. The following paragraphs contain additional information on and measurement techniques for ac voltage and current measurements.

2-86. TRUE-RMS MEASUREMENTS

2-87. One of the most useful features of the 8050A is the direct measurement of true-rms ac voltages and ac current. Mathematically, rms is defined as the square root of the mean of the squares of the instantaneous voltages. In physical terms, rms is equivalent to the dc value that dissipates the same amount of heat in a resistor as the original waveform. True-rms is the effective value of any waveform and represents the energy level of the signal. It is used directly in the relationships of Ohm's Law and provides a reliable basis for comparisons of dissimilar waveforms.

2-88. Most multimeters in use today have average-responding ac converters rather than true-rms converters like the 8050A. Usually the gain in average-responding meters is adjusted so that the reading gives the rms value, provided the input signal is a harmonic-free sinusoid. However, if the signal is not sinusoidal, the average-responding meter does not give a correct rms reading.

2-89. The 8050A ac converter calculates the rms value through analog computation. This means that 8050A readings are accurate rms values for mixed frequencies, modulated signals, square waves, sawtooths, 10%-duty-cycle pulses, etc.

2-90. WAVEFORM COMPARISON (RMS VS AVERAGING METERS)

2-91. Figure 2-14 shows the relationship between common waveforms and the display readings of the 8050A compared to average-responding meters. Figure 2-14 also illustrates the relationship between ac and dc measurements for ac-coupled meters. For example, the first waveform (in Figure 2-14) is a sine wave with a peak voltage of 1.414V. Both the 8050A and the average responding meters display the correct rms reading of 1.000V (the dc component equals 0). However, the 1.414V (peak) rectified square wave produces a correct dc reading (0.707V) on both meters but only the 8050A correctly measures the ac component (0.707V). The average responding meter measures the ac component of the rectified square as 0.785V, which is an error of 5.6%.

2-92. CREST FACTOR

2-93. The crest factor of a waveform is the ratio of the peak to rms voltage. In waveforms where the positive and negative half-cycles have different peak voltages, the higher voltage is used in computing the crest factor. Crest factors start at 1.0 for a square wave (peak voltage equals rms voltage).

1. Using the dB function on the 8050A measure the voltage at TP1 (or intended reference).
2. While measuring the intended reference, set the RELATIVE switch to ON.
3. In this circuit, 1 mV becomes the 0 dB reference. All subsequent dB measurements in the circuit are displayed as the loss or gain of the circuit in dB.

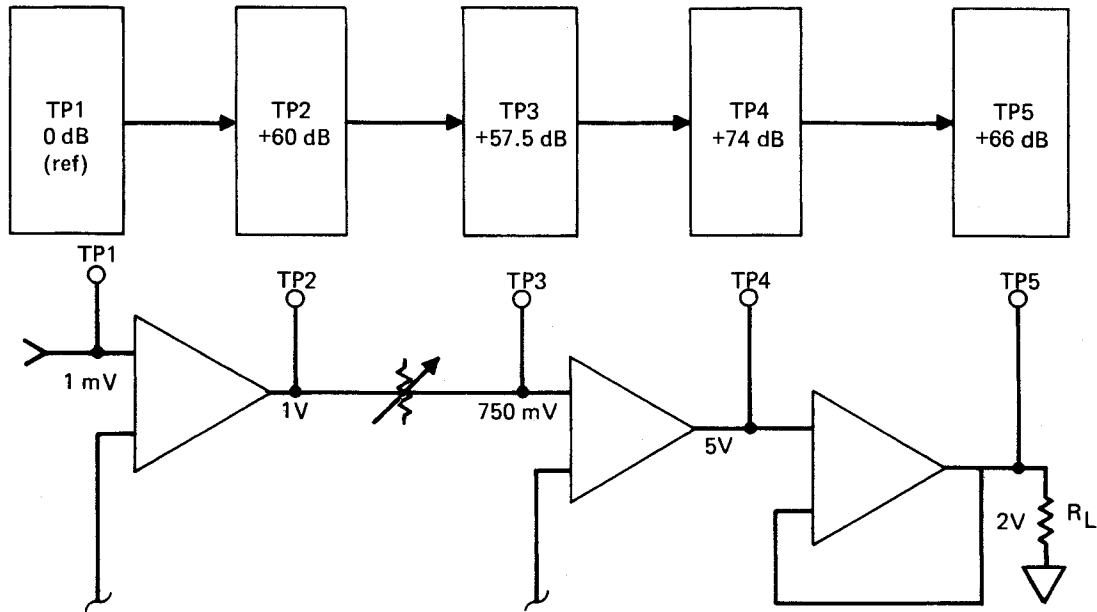

Figure 2-13. dB Circuit Gain or Loss Measurements

2-94. The 8050A can measure signals with a crest factor of 3.0 or less, at full scale. Figure 2-15 illustrates some typical signals and their crest factors. The waveforms in Figure 2-15 show that a signal with a crest factor of greater than 3.0 is not common.

2-95. To ensure that a signal measured with the 8050A has a crest factor below 3.0, measure the peak value with an ac coupled oscilloscope. If the peak value is not more than three times the true-rms reading of the 8050A, then the signal's crest factor is 3.0 or less. Another method of verifying the error caused by the crest factor of a signal is to compare the reading of the 8050A with a reading on the next higher range of the 8050A. The 8050A crest factor capability increases from 3.0 for readings less than full-scale. The crest factor capability of the 8050A is shown by the following equation:

$$\text{Crest Factor Capability} = 3\sqrt{\frac{\text{Range}}{\text{Input}}}$$

The error caused by exceeding the crest factor of 3.0 at full scale, will be reduced significantly on the next higher

measurement range of the 8050A. The crest factor capability at 1/10 scale approaches 10.

2-96. COMBINED AC AND DC SIGNAL MEASUREMENTS





2-97. It is sometimes necessary to measure an ac signal riding on a dc level. An example of this type of signal is shown in Figure 2-16. To obtain an accurate measurement of the total rms value for these signals, perform the following steps:

1. Measure the ac component of the signal using the AC V function.
2. Measure the dc component of the signal using the DC V function.
3. Use the following formula with the values obtained in steps 1 and 2 to determine the total rms value of the signal:

Total RMS Value =

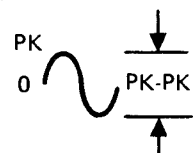
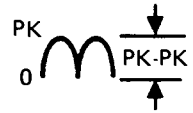
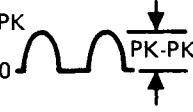
$$\sqrt{(\text{ac component rms})^2 + (\text{dc component})^2}$$

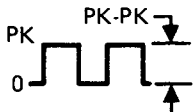
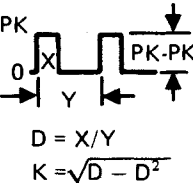
OPERATION
AC VOLTAGE/CURRENT MEASUREMENT

AC-COUPLED INPUT WAVEFORM	PEAK VOLTAGES		DISPLAY READINGS			DC AND AC TOTAL RMS
	PEAK to PEAK	PEAK	AC COMPONENT ONLY		DC COMPONENT ONLY	
			RMS CAL*	8050A		TRUE-RMS= $\sqrt{ac^2 + dc^2}$
SINE 	2.828	1.414	1.000	1.000	0.000	1.000
RECTIFIED SINE (FULL WAVE) 	1.414	1.414	0.421	0.436	0.900	1.000
RECTIFIED SINE (HALF WAVE) 	2.000	2.000	0.779	0.771	0.636	1.000
SQUARE 	2.000	1.000	1.111	1.000	0.000	1.000
RECTIFIED SQUARE 	1.414	1.414	0.785	0.707	0.707	1.000
RECTANGULAR PULSE  $D = X/Y$ $K = \sqrt{D - D^2}$	2.000	2.000	$4.442K^2$	2K	2D	$2\sqrt{D}$
TRIANGLE SAWTOOTH 	3.464	1.732	0.962	1.000	0.000	1.000

* RMS CAL IS THE DISPLAYED VALUE FOR AVERAGE RESPONDING METERS THAT ARE CALIBRATED TO DISPLAY RMS FOR SINE WAVES

Figure 2-14. Waveform Comparisons









WAVEFORM	CREST FACTOR
SQUARE WAVE 	1.0
SINE WAVE 	1.414
TRIANGLE SAWTOOTH 	1.732
MIXED FREQUENCIES 	1.414 to 2.0
SCR OUTPUT OF 100% - 10% 	1.414 to 3.0
WHITE NOISE 	3.0 to 4.0
AC COUPLED PULSE TRAIN 	$3.0\sqrt{b/a - 1}$
SPIKE 	> 9.0

Figure 2-15. Crest Factor

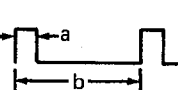
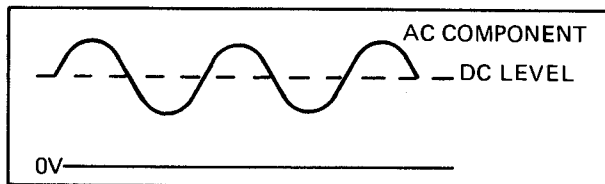

Figure 2-16. Total RMS Value

2-98. Affects of Offset in AC Measurements

2-99. The 8050A is a true-rms-responding multimeter, and the display will indicate a reading of typically 10 to 20 digits (because of amplifier noise) when the input is shorted in the AC V or AC mA functions. The accuracy of the 8050A is not affected by this internal offset even when measured inputs are at the specified floor of the multimeter (5% of the range selected). When the rms value of the two signals (internal offset and 5% of range input) is calculated, as in the following equation, the insignificant effect of the offset is shown:

$$\text{Total rms digits} = \sqrt{20^2 + 1000^2} = 1000.2$$

The display of the 8050A will read 1000 digits.

2-100. BANDWIDTH LIMITATIONS

2-101. Signals with rectangular waveforms contain component frequencies that are much higher than the fundamental frequency used to describe them. The component frequencies, for rise times less than 1 microsecond, exceed the 200 kHz bandwidth of the 8050A (and will produce a low reading display). For example, a 10-kHz square wave with a rise time of less than 1 microsecond will produce a display reading that is approximately 1% low and proportionally lower for higher frequency square waves.

2-102. MEASURING AMPLIFIER BANDWIDTH

2-103. The ac voltage, dB, and RELATIVE functions can be used together to measure the frequency response (bandwidth) of an ac circuit. Use the following procedure to measure the bandwidth of an amplifier.

1. Connect the amplifier, signal generator, load, and 8050A as shown in Figure 2-17.
2. On the 8050A, select the AC V function and a range appropriate for the output of the amplifier.
3. Adjust the signal generator for a signal level that is within the input operating range of the amplifier.
4. Turn on the test equipment.
5. Beginning at a low frequency (20 Hz), steadily increase the output frequency of the signal generator while observing the ac voltage reading on the 8050A. Typically the ac voltage readings will rise to a peak, level out, then begin to fall. An example of this response curve is shown in Figure 2-17.
6. Reduce the output frequency of the signal generator to the peak or start of the upper plateau of the ac voltage readings.
7. On the 8050A, select the dB function, then set the RELATIVE switch to ON. This establishes the 0 dB relative reference.
8. Increase the output frequency of the signal generator until the dB reading reaches -3.00 dB. Note the frequency of the signal generator. This will be the upper frequency limit of the bandwidth.
9. Decrease the output frequency of the signal generator so the dB readings increase to 0 dB

OPERATION
AC VOLTAGE/CURRENT MEASUREMENT

and then drop again to -3.00 dB. Note the frequency of the signal generator. This will be the lower frequency limit of the bandwidth.

2-104. A similar technique can be used to determine the frequency response of other ac circuits, such as high-pass or low-pass filters, notch filters, etc.

2-105. FINDING THE Q OF A SINGLE TUNED CIRCUIT

2-106. Use the following equation and the application technique for measuring the bandwidth of a circuit, to find the Q of a single tuned circuit:

$$Q = \frac{\text{Resonant Frequency}}{2 \times \text{Bandwidth}}$$

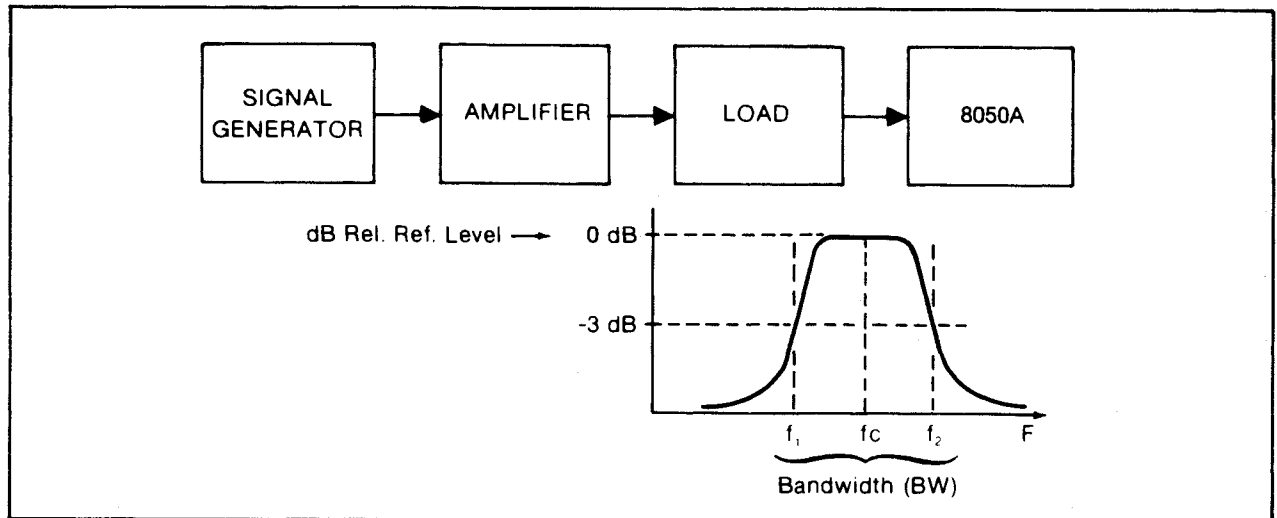

Figure 2-17. Measuring Amplifier Bandwidth

Section 3

Theory of Operation

3-1. INTRODUCTION

3-2. The theory of operation of the 8050A is discussed on two levels. First, the Functional Description discusses the operation of the DMM in terms of the functional relationships of the major circuits. Second, the Circuit Description presents a more detailed discussion of the major circuits. Both levels are illustrated by block diagrams and simplified schematics in this section and the schematic diagrams in Section 7.

3-3. FUNCTIONAL DESCRIPTION

3-4. The major circuits of the 8050A are shown in the functional block diagram in Figure 3-1. The range and function switches route the unknown input signal through the signal conditioners. The signal conditioners develop a dc voltage at the input to the a/d converter that is proportional to the unknown input signal. The a/d converter, working in conjunction with the microcomputer, converts the dc analogue of the unknown input signal to a digital value. The microcomputer processes the digital value and displays the result on the LCD.

3-5. CIRCUIT DESCRIPTION

3-6. The following paragraphs describe each of the major circuits in detail.

3-7. A/D Converter

3-8. The a/d converter in the 8050A uses the dual slope method of conversion. In this method, the voltage analogue of the input signal (proportional to the unknown input signal) is allowed to charge a capacitor (integrate) for an exact length of time. The capacitor is then discharged by a reference voltage. The length of time required for the capacitor to discharge is proportional to the unknown input signal. The microcomputer measures the discharge time and displays the result. The following

paragraphs discuss the actual a/d conversion in more detail.

3-9. The microcomputer controls the a/d converter via CMOS switches. Figure 3-2 shows the simplified circuits formed during the major periods of a/d conversion cycles. Figure 3-3 is a timing diagram that shows the a/d converter cycle resulting from three different input signals. Assume in reading the following paragraphs that the DC V function and the 2V range are selected, and the DMM is nearing the end of the Autozero period in its conversion cycle.

3-10. As Part A in Figure 3-2 shows, the CMOS switches U18B and U19A are closed, providing voltage levels that allow C8 and C33 to store the offset voltages of the buffer, integrator, and comparator. CMOS switches U18D and U19B connect the flying capacitor, C7, to a reference voltage. Since the V function is selected, C7 is charged by the a/d converter reference voltage source. At the end of the Autozero period, C7 is fully charged, C8 and C33 are charged up to the offset voltages, and the comparator output (CM) is near a threshold level.

3-11. Assume that an input of -1.0000V dc is present at the DMM input (first set of waveforms in Figure 3-3). The microcomputer starts the Integrate command (INT) at the same time that it ends the AZ command. The a/d converter circuit is switched to the configuration shown in Figure 3-2, Part B. CMOS switch U18A connects the output of the signal conditioners to the input terminal of the buffer. For the 2V range, the microcomputer selects the X1 gain in the buffer, and the input from the signal conditioner is applied to the buffer and integrator in series. The integrator begins to charge C9. The instant that the charge on C9 shifts from its initial level, the comparator toggles, and its Compare output (CM) goes to a steady level. Since the unknown input to the DMM is

THEORY OF OPERATION

CIRCUIT DESCRIPTION

negative, the buffer goes negative, the integrator goes positive, and CM will go negative. C9 will continue to charge until the end of the 100 millisecond Integrate period. The microcomputer-controlled Integrate period is exactly the same length for every measurement cycle, regardless of the range and function selected.

3-12. After the microcomputer ends the Integrate period, it prevents the integrate capacitor, C9, from charging or discharging during a brief Hold period. During the Hold period the microcomputer examines the polarity of CM to determine the polarity of the unknown input to the DMM.

3-13. Since CM is negative, the microcomputer initiates the Read period with the DE (+R) (de-integrate plus reference) command (Part C of Figure 3-2), CMOS switch U18B connects the buffer input to COMMON, and CMOS switches U20A and U20B connect C7 in the buffer feedback loop so that the integrator input is a known level (1V) of the opposite polarity from the input signal. The integrate capacitor, C9, begins to discharge, and the microcomputer starts to count from 00000. The count accumulates until C9 discharges to its initial level. The instant C9 reaches its initial level, the comparator toggles CM positive, stopping the count in the microcomputer. The count in this case will be 10,000. This count (with the appropriate decimal point) is numerically the same as the -1.0000V dc input to the DMM.

3-14. The third set of waveforms shows the timing that would result from a positive full-scale input (in our example, +1.9999V dc). Note that for positive inputs, CM is positive so the microcomputer uses the DE (-R) (de-integrate minus reference) command during the READ period. This connects C7 so that its polarity is reversed (as it must be to discharge C9).

3-15. The bottom set of waveforms in Figure 3-3 shows the timing that results from a positive overrange input to the DMM. If the count in the microcomputer reaches 20,000 before CM toggles, the microcomputer detects this as an overrange condition and issues the overload (\overline{OL}) command for 5 millisecond. The \overline{OL} signal shorts C9, dumping the remaining charge. The following Autozero period is doubled to 200 millisecond. The polarity of the overrange input signal is retained and displayed.

NOTE

The display indicates an overload, between 20,000 and 20,055 counts, but the a/d converter continues to integrate normally, and OL indicator does not appear.

3-16. The a/d reference scheme is different if either the k Ω or S functions are selected. When the 2 mS, 200 Ω , or 2 k Ω range is selected, flying capacitor C7 is charged during

the Autozero period by the voltage drop across the reference resistor instead of the a/d converter reference voltage source. In k Ω , during the Integrate period, the voltage drop across the unknown resistance is integrated. During the Read period, the buffer input is connected to COMMON, and C7 is connected in the feedback loop of the buffer. Therefore, the count accumulated in the microcomputer during the Read period is proportional to the ratio:

$$\frac{V_{RX}}{V_{\Omega REF}} = \frac{UNKNOWN V}{REFERENCE V}$$

or the ratio of voltage drops across the unknown and reference resistors. If any of the other ranges is selected, flying capacitor C7 is charged from the high side (VH) of the reference resistor. During the Integrate period, the voltage drop across the unknown resistance is integrated. During the Read period, the low end of the reference resistor (VL) is connected to the buffer input and C7 is connected in the buffer feedback loop. The count is again proportional to the ratio:

$$\frac{V_{RX}}{V_H - V_L} = \frac{UNKNOWN V}{REFERENCE V}$$

or the ratio of voltage drops across the unknown and reference resistors.

3-17. For conductance measurements, the microcomputer sends the DE (-R) command after the Autozero period, and then the INT command. This inverts the measurements ($S=1/\Omega$).

3-18. Microcomputer

3-19. The microcomputer (Figure 3-4) performs four functions: control, measurement, calculation, and display drive. The positions of the front panel switches determine how the microcomputer performs each of these functions. The microcomputer controls the gain and timing of the a/d converter and the gain of the ac buffers in accordance with the measurement function and range selected. The microcomputer measures the output of the a/d converter by accumulating counts. In any measurement function the count accumulates linearly (count pulses evenly spaced). The total count is numerically the same as the unknown input to the DMM (a 1.5001V input results in an accumulated count of 15001). If the dB function is selected, the microcomputer calculates the dB reading from the linear reading based on the reference impedance (REF Z) selected. When the RELATIVE switch is set to the ON position, the microcomputer drives the display so that the REL annunciator appears, and the microcomputer stores the first measurement value as the relative reference. This relative reference is algebraically subtracted from subsequent measurements made in that measurement function until the RELATIVE switch is set to the OFF position.

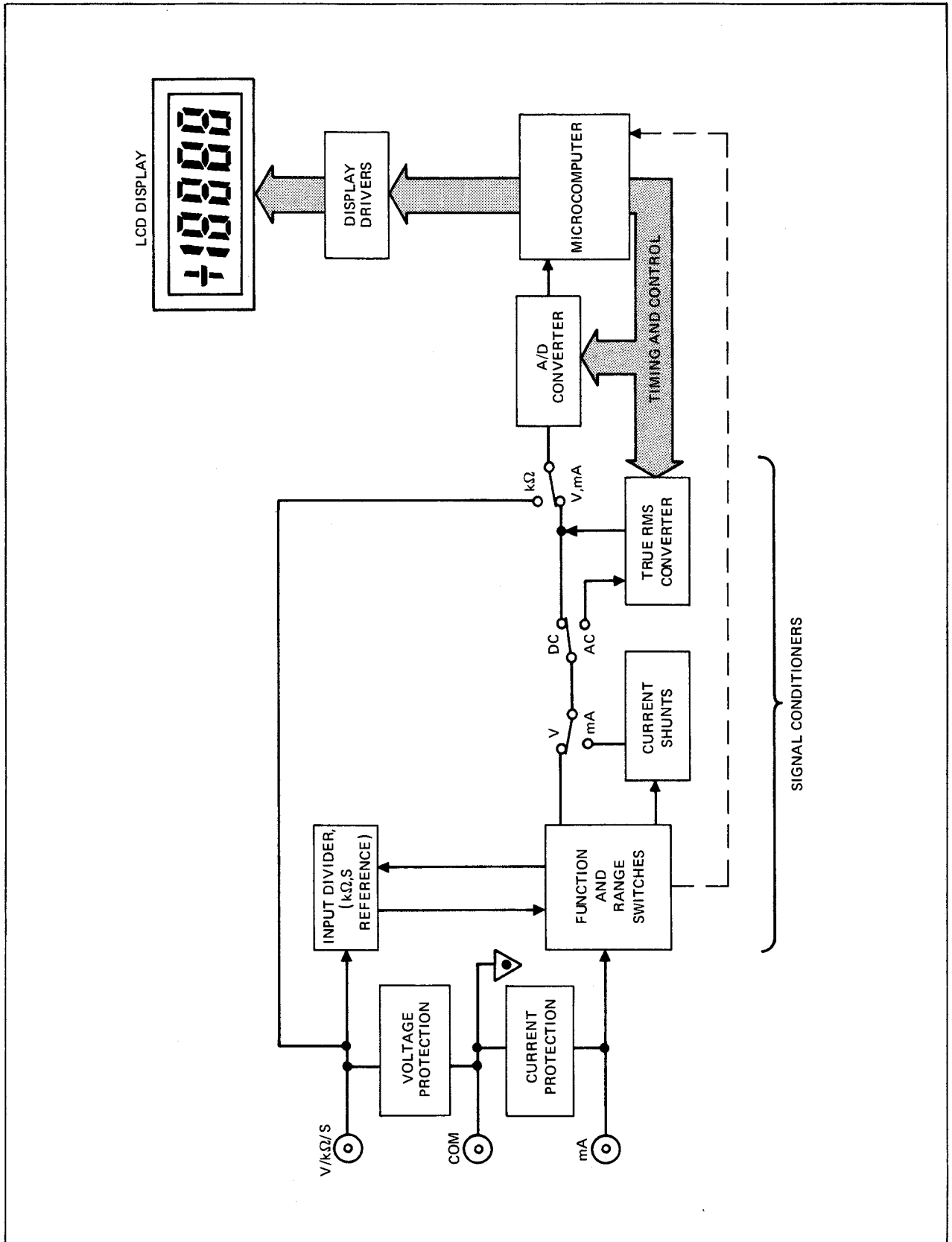

Figure 3-1. 8050A Functional Block Diagram

THEORY OF OPERATION
CIRCUIT DESCRIPTION

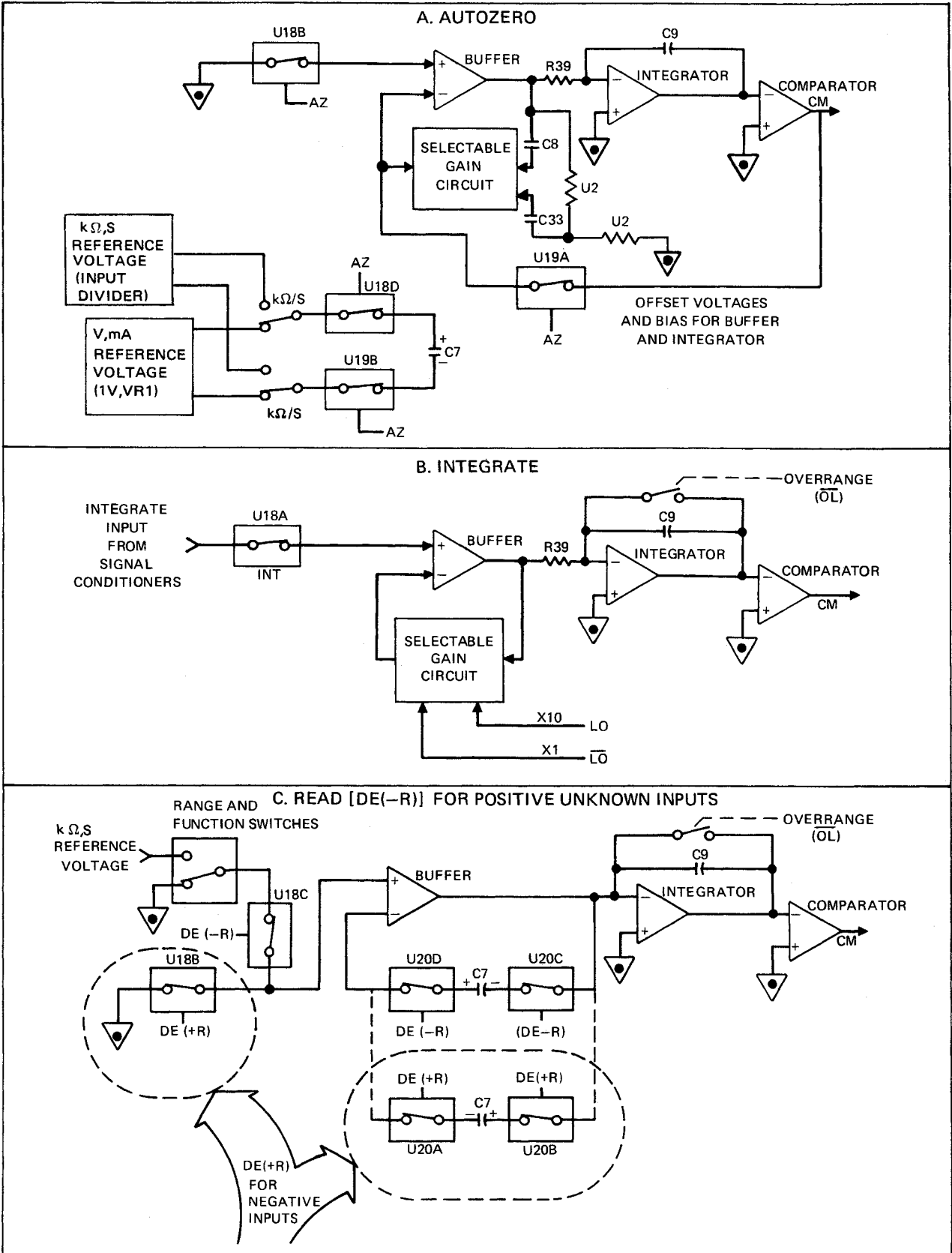

Figure 3-2. A/D Converter

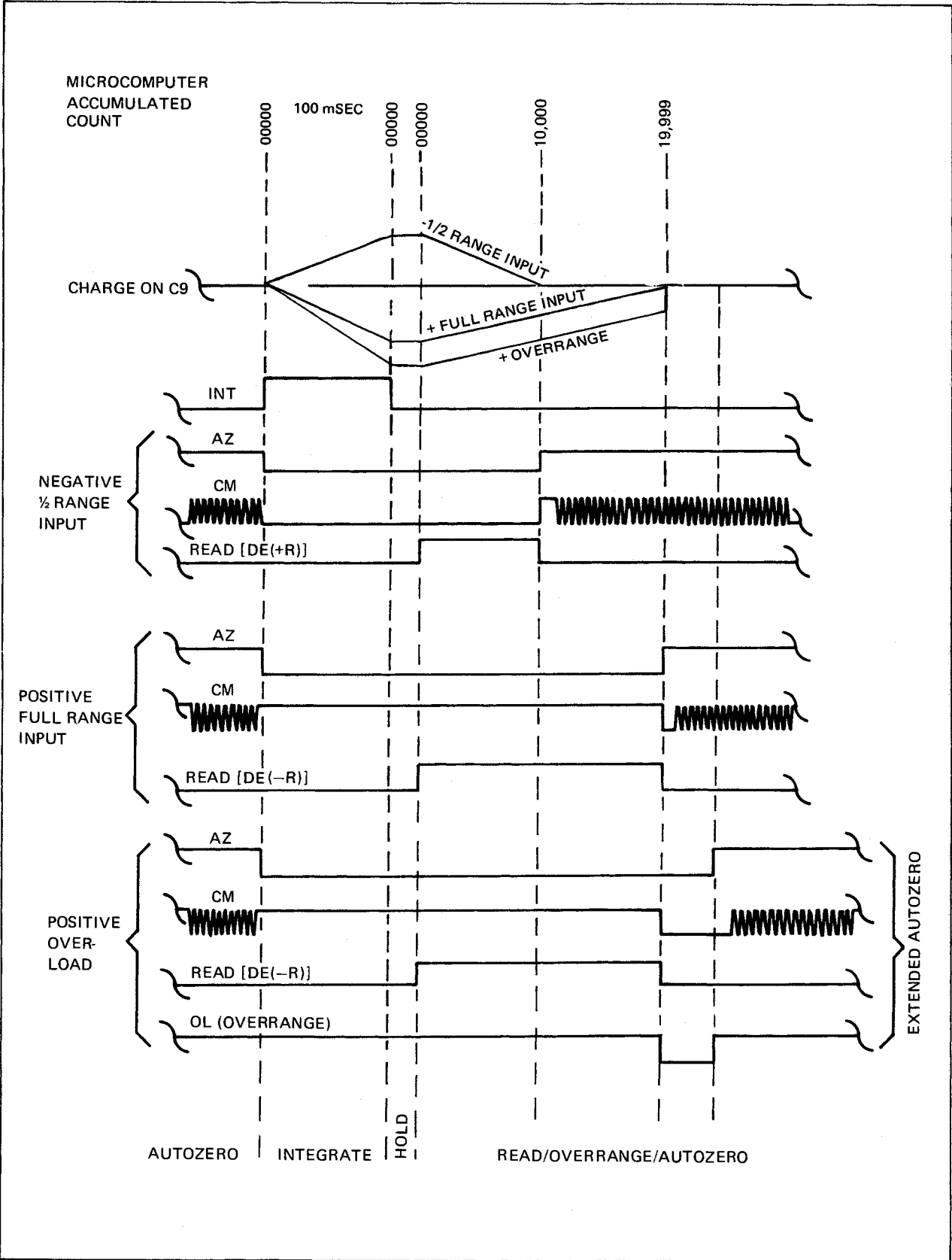

Figure 3-3. A/D Converter Waveforms

THEORY OF OPERATION
SIGNAL CONDITIONING

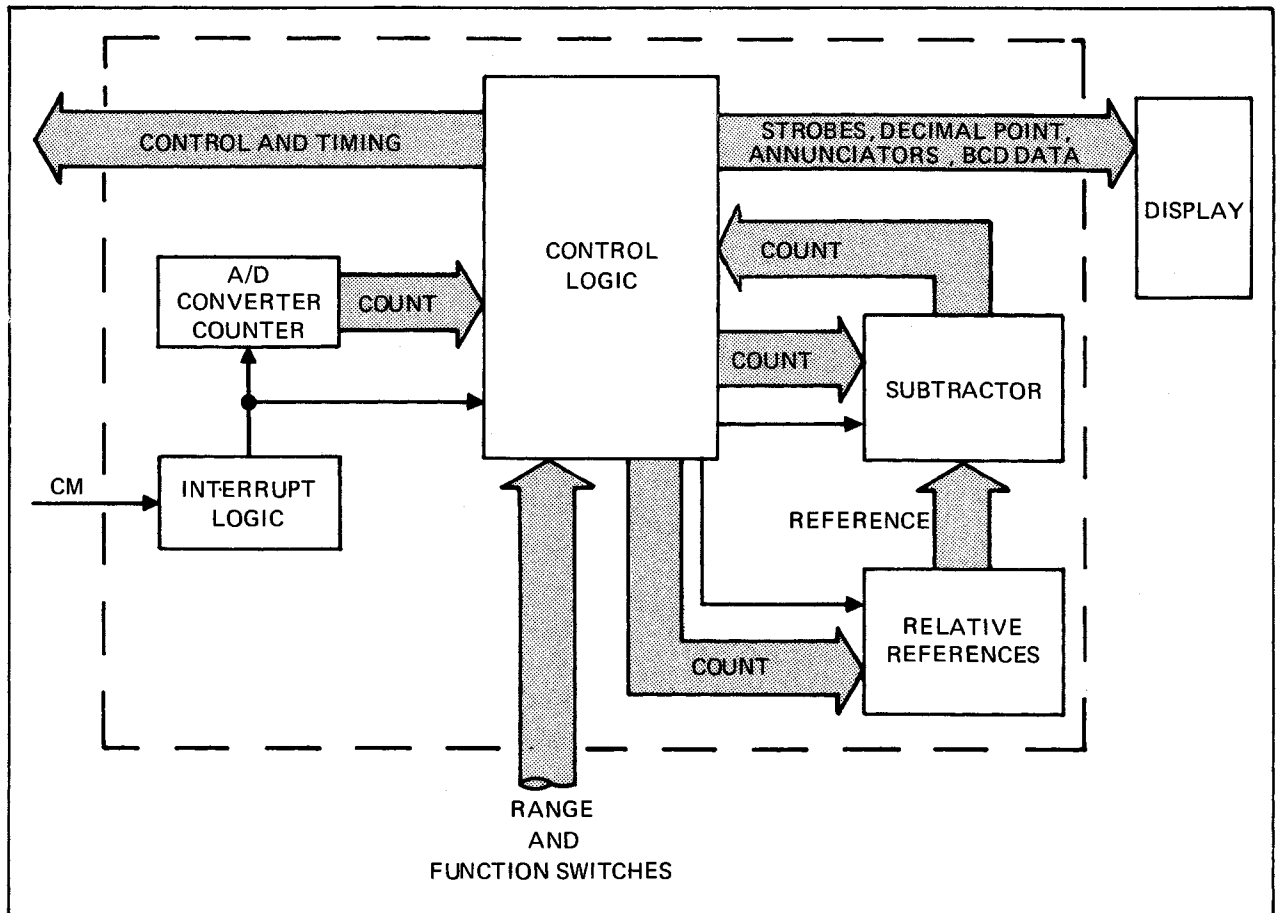

Figure 3-4. Microcomputer Simplified Block Diagram

3-20. Signal Conditioning

3-21. Some 8050A inputs must be scaled and/or conditioned before being presented to the a/d converter. For example, high voltage levels must be attenuated, and ac inputs must be attenuated and converted into the equivalent dc voltage levels. The a/d converter has two ranges: ± 200 mV full-scale and ± 2 V full-scale. The following paragraphs describe the signal conditioning circuits.

3-22. VOLTAGE SIGNAL CONDITIONING

3-23. As Part A of Figure 3-5 shows, the voltage signal conditioning is accomplished with an input voltage divider network. The division factor of the network is determined by the range selected: 1/100 for the 20 and 200V ranges, 1/1000 for the 1000V dc (750V ac) range. If the AC/DC switch is in the AC position, the output of the divider network will be routed through the true-rms converter to the a/d converter. If the AC/DC switch is in the DC position, the output of the divider network is routed directly to the a/d converter. If the k Ω switch is

selected (ohms or conductance), the input divider resistors are used as the reference resistors.

3-24. CURRENT SIGNAL CONDITIONING

3-25. As Part B of Figure 3-5 shows, current measurements are made using a selected value current shunt to perform the current-to-voltage conversion required by the a/d converter. The range switches determine the value of the current shunt, thus determining the scale of the voltage level developed across the shunt. If the AC/DC switch is in the DC position, the output of the current shunt is applied to the input of the a/d converter. If the AC/DC switch is in the AC position, the voltage level developed across the shunt is applied to the input of the rms converter.

3-26. RESISTANCE/CONDUCTANCE SIGNAL CONDITIONING

3-27. Resistance and conductance measurements made on the 2 mS, 200 Ω , and 2 k Ω ranges use a direct ratio technique. Other ranges use a subtraction and ratio technique to indirectly derive a ratio.

THEORY OF OPERATION
SIGNAL CONDITIONING

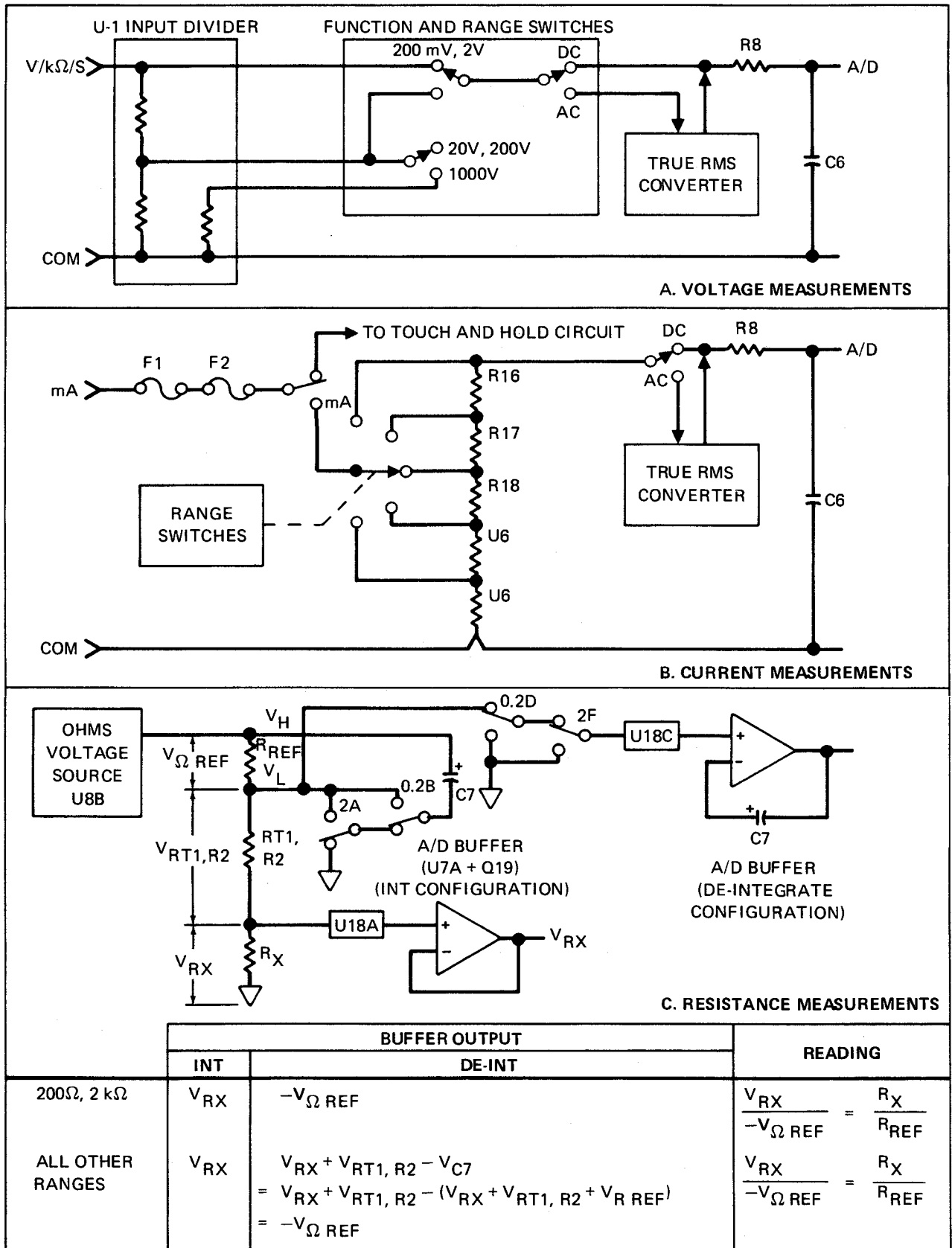

Figure 3-5. Signal Conditioning

THEORY OF OPERATION
TRUE-RMS CONVERTER

3-28. As Part C of Figure 3-5 shows, when the 2 mS, 200Ω, or 2 kΩ range is selected, the voltage drop across the unknown resistance is measured in relation to the voltage drop across the known reference resistor, and since the same current is flowing through both resistors, the value of the unknown resistance can be computed using the formula:

$$\frac{V_{RX}}{-V_{\Omega REF}} = \frac{R_X}{R_{REF}}$$

(Minus $V_{\Omega REF}$ is necessary for de-integration during the Read period.)

3-29. As Part C of Figure 3-5 shows, when any range but 2 mS, 200Ω, or 2 kΩ is selected, the voltage drop across the unknown resistance is measured, and C7 charges up to the ohms voltage source, VH. During the Read period, the a/d buffer subtracts the voltage on C7 from VL, thereby obtaining $-V_{\Omega REF}$.

3-30. For conductance measurements, the microcomputer inverts the kΩ measurements ($S=1/\Omega$) by reversing the order of the Integrate and Read periods of the a/d converter.

3-31. True-RMS Converter

3-32. The true-rms converter is made up of two ac buffers and a hybrid true-rms converter.

3-33. AC BUFFERS

3-34. The ac buffers consist of operational amplifiers U23, U21, and their associated components. Through the buffers, the input signal is scaled to a level within the range of the hybrid true-rms converter. Each buffer has a gain of 1 or 10 which is controlled by the microcomputer. Refer to Table 3-1 for the buffer gains selected for each range. In the dB function with the 200 mV range selected, the buffers auto-range through X1, X10, and X100 gains depending on the input signal level. Thus in this mode, the 8050A appears to have a single range from -60 dBm to +8 dBm (600Ω Reference impedance). Upranging occurs at the linear ac range equivalent of 20,000 counts; downranging occurs at the equivalent of 1,800 counts.

3-35. The output of the first buffer is divided in half and then amplified by a factor of two in the hybrid true-rms converter. This reduces the required dynamic range of the true-rms converter amplifier by a factor of two, thereby accommodating waveforms with crest factors up to 3 at full scale.

3-36. HYBRID TRUE-RMS CONVERTER

3-37. An rms amplitude is the value of alternating voltage that results in the same power dissipation in a given resistance as a dc voltage of the same numerical

value. The mathematical formula for computing the rms value of a dc voltage is:

$$V_{rms} = \sqrt{V_i^2}$$

where V_i is the instantaneous voltage at any given point in time and V_i^2 is the average of V_i^2 . The rms converter in your 8050A monitors the instantaneous voltage and computes the rms value of the input signal. Figure 3-6 shows the mathematical derivation of the implicit rms conversion circuit in your 8050A and a block diagram of that circuit.

3-38. Touch-Hold Circuit

3-39. The touch-hold circuit operates in conjunction with the 80T-H Touch-Hold Probe. The touch-hold circuit works in all measurement functions except mA and dB. If any valid function is selected, and the control switch on the 80T-H Probe is pressed, the touch-hold circuit places a logic zero (-5V) on the T & H input (pin 16) of the microcomputer. At this signal, the microcomputer freezes the display with the data present when the control switch was pressed. Touch-Hold will not operate if Fuse F1 and/or F2 is blown.

3-40. Voltage Protection

3-41. In the volts mode of operation, protection against inputs and transients above the input ratings of the 8050A is provided by metal oxide varistors RV1, RV2, and RV3, and by R1, R2, and Q1. RV1, RV2, and RV3 clamp the voltage across the measurement circuitry at approximately ±1200V while R1 and R2 limit the input current.

3-42. In the kΩ mode of operation, protection is provided by thermistor RT1 and the clamp/zener action of Q2. As RT1 heats up, its resistance increases sharply.

3-43. Current Protection

3-44. In the current mode of operation, diode bridge U28 and diode CR1 clamp the voltage across the current shunts until the fuses F1 and F2 blow. Backup fuse F2 is used to clear open voltages between 250V and 600V.

Table 3-1. AC Buffer Gains

RANGE	FIRST BUFFER	SECOND BUFFER	OVERALL GAIN
200 mV, dB only	Auto-range only		X1, X10, X100
200 mV, Linear	X1	X10	X10
2V	X1	X1	X1
20V	X1	X10	X10
200V	X1	X1	X1
750V	X1	X1	X1

GIVEN: $V_{rms} = \sqrt{\overline{V_i^2}}$ Where V_i is the instantaneous ac voltage.

THEN: $V_{rms}^2 = \overline{V_i^2}$

$V_{rms} = \frac{\overline{V_i^2}}{V_{rms}} = \text{antilog} \left(\log \frac{\overline{V_i^2}}{V_{rms}} \right) = \text{antilog} (2 \log \overline{V_i} - \log V_{rms})$

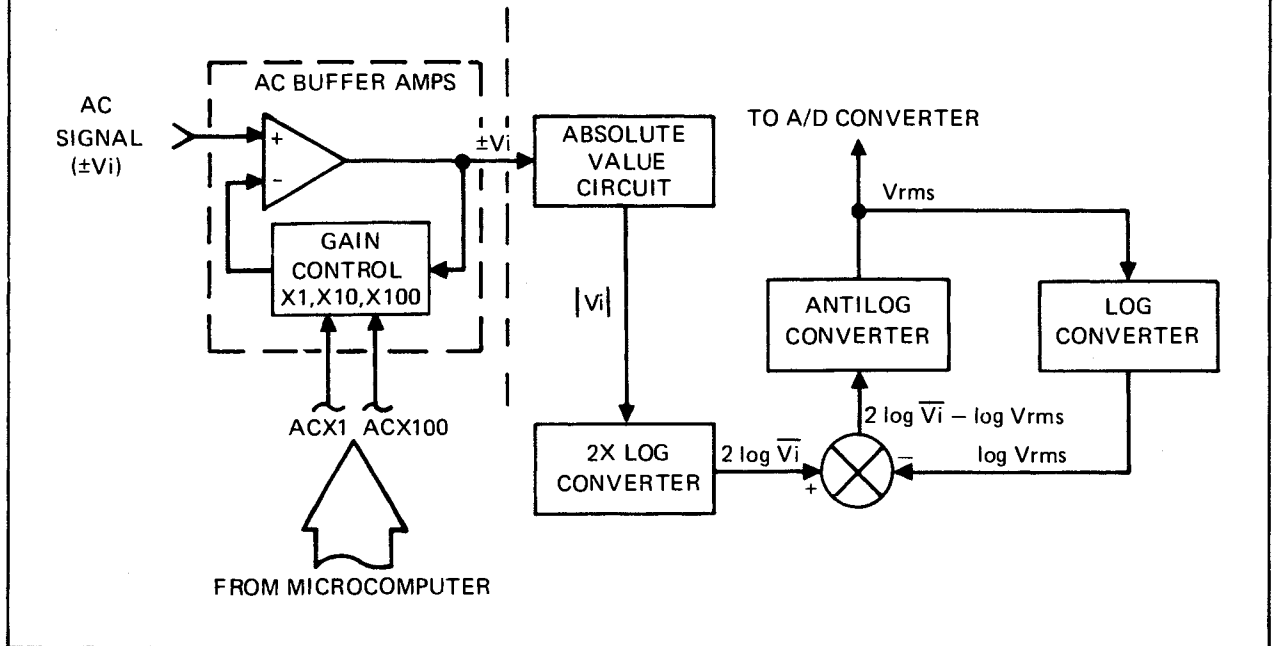

Figure 3-6. RMS Converter



static awareness



A Message From
John Fluke Mfg. Co., Inc.

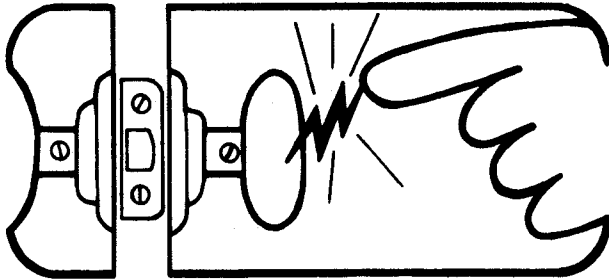

Some semiconductors and custom IC's can be damaged by electrostatic discharge during handling. This notice explains how you can minimize the chances of destroying such devices by:

1. Knowing that there is a problem.
2. Learning the guidelines for handling them.
3. Using the procedures, and packaging and bench techniques that are recommended.

The Static Sensitive (S.S.) devices are identified in the Fluke technical manual parts list with the symbol



The following practices should be followed to minimize damage to S.S. devices.

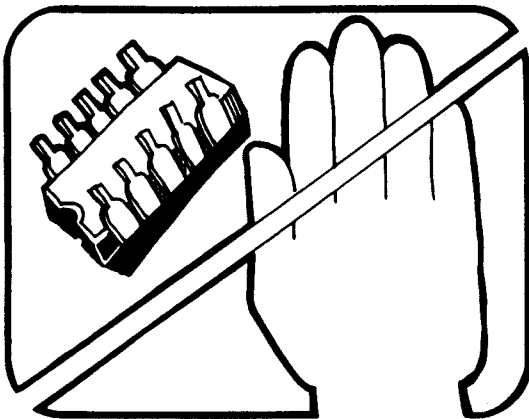

1. MINIMIZE HANDLING

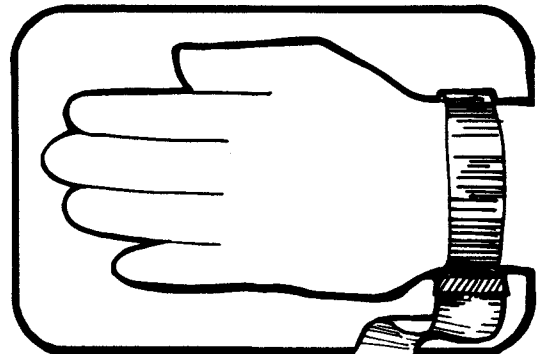

3. DISCHARGE PERSONAL STATIC BEFORE HANDLING DEVICES

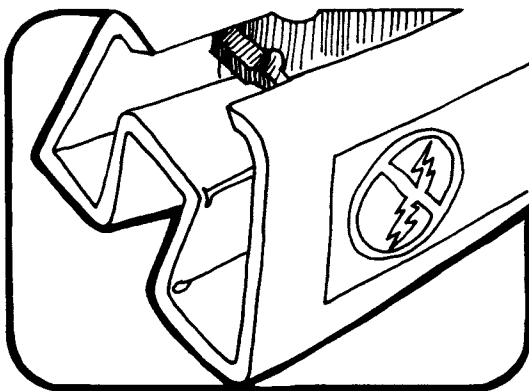

2. KEEP PARTS IN ORIGINAL CONTAINERS UNTIL READY FOR USE.

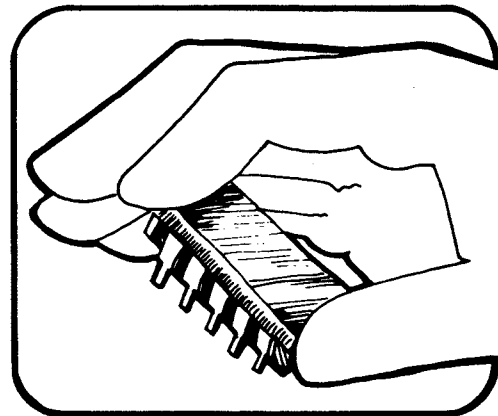

4. HANDLE S.S. DEVICES BY THE BODY

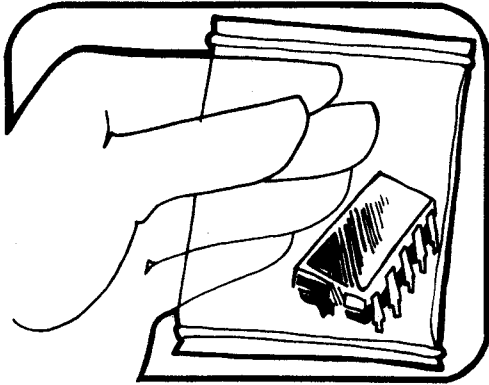

5. USE ANTI-STATIC CONTAINERS FOR HANDLING AND TRANSPORT

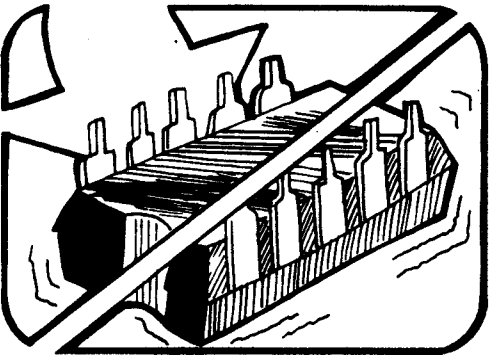

6. DO NOT SLIDE S.S. DEVICES OVER ANY SURFACE

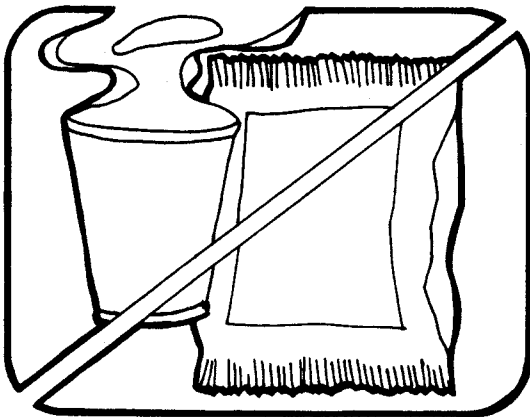

7. AVOID PLASTIC, VINYL AND STYROFOAM® IN WORK AREA

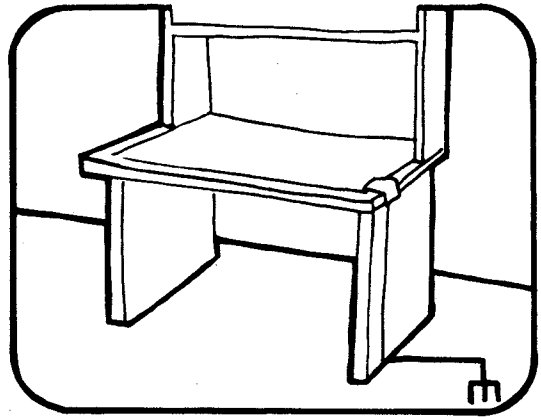

8. HANDLE S.S. DEVICES ONLY AT A STATIC-FREE WORK STATION
9. ONLY ANTI-STATIC TYPE SOLDER-SUCKERS SHOULD BE USED.
10. ONLY GROUNDED TIP SOLDERING IRONS SHOULD BE USED.

Anti-static bags, for storing S.S. devices or pcbs with these devices on them, can be ordered from the John Fluke Mfg. Co., Inc.. See section 5 in any Fluke technical manual for ordering instructions. Use the following part numbers when ordering these special bags.

John Fluke Part No.	Bag Size
453522	6" x 8"
453530	8" x 12"
453548	16" x 24"
454025	12" x 15"

PORTIONS REPRINTED
WITH PERMISSION FROM TEKTRONIX, INC.
AND GENERAL DYNAMICS, POMONA DIV.

Section 4 Maintenance

WARNING

THESE SERVICING INSTRUCTIONS ARE FOR USE BY QUALIFIED PERSONNEL ONLY. TO AVOID ELECTRICAL SHOCK, DO NOT PERFORM ANY SERVICING OTHER THAN THAT CONTAINED IN THE OPERATING INSTRUCTIONS UNLESS YOU ARE QUALIFIED TO DO SO.

4-1. INTRODUCTION

4-2. This section of the manual contains maintenance information for the 8050A. This includes access procedures, disassembly and replacement procedures, performance tests, calibration adjustments, and troubleshooting procedures. The performance tests are recommended as an acceptance test when the instrument is first received. The performance tests can also be used as part of a routine preventive maintenance schedule.

4-3. A one-year calibration cycle is recommended to maintain specifications given in Section 1 of this manual. The test equipment required for the performance tests or calibration adjustments is listed in Table 4-1. Test equipment with equivalent specifications may be substituted for the recommended model.

4-4. SERVICE INFORMATION

4-5. The 8050A is warranted for a period of one year upon shipment to the original purchaser. Conditions of the warranty are given at the front of this manual. Malfunctions that occur within the limitation of the warranty will be corrected at no cost to the purchaser. For in-warranty repair, call (toll-free) 800-426-0361 for the address of the nearest Fluke Technical Service Center. In Alaska, Hawaii, Washington, or Canada call 206-356-5400 (toll-call). Ship the instrument postpaid in the original container. If the original container is not

available, pack the instrument in a sturdy carton with at least three inches of non-settling padding on all sides. Dated proof-of-purchase may be required for in-warranty repairs.

4-6. Fluke Technical Service Centers are also available for calibration and/or repair of instruments that are beyond the warranty period. Call the number listed above for shipping instructions. Ship the instrument and remittance in accordance with the instructions received.

4-7. GENERAL INFORMATION

4-9. Interior Access

4-10. The instrument has two pcb assemblies: the Main PCB Assembly and the Display PCB assembly. To gain access to the calibration adjustments, the backup fuse, or the ac line transformer, only the case needs to be removed. Some troubleshooting can also be accomplished with only the case removed. Other troubleshooting procedures may require the removal of the Display PCB assembly.

CAUTION

To avoid contaminating the pcb assemblies with oil from the fingers, handle the assemblies by the edges or wear gloves. If an assembly does become contaminated, refer to the information on cleaning pcb's given later in this section.

5. To reassemble, reverse the preceding procedures in logical order.

4-15. DISPLAY PCB REMOVAL

4-16. Use the following procedure to remove the Display PCB from the instrument:

1. Complete the Display PCB Access procedure.
2. Remove the screws (two) from the plastic bar that clamps the Interconnect cable to the Display PCB.
3. Remove the plastic bar and gently lift the Interconnect cable from the sides. To avoid contamination, do not touch the metal

contact strips on the underside of the Interconnect cable.

4. To reassemble, reverse the preceding procedures in logical order.

4-17. LCD REMOVAL

4-18. Use the following procedure to remove the LCD (Liquid Crystal Display) from the Display PCB Assembly:

1. Complete the Display PCB Access procedure.
2. Remove the two screws located on the foil side of the Display PCB Assembly.

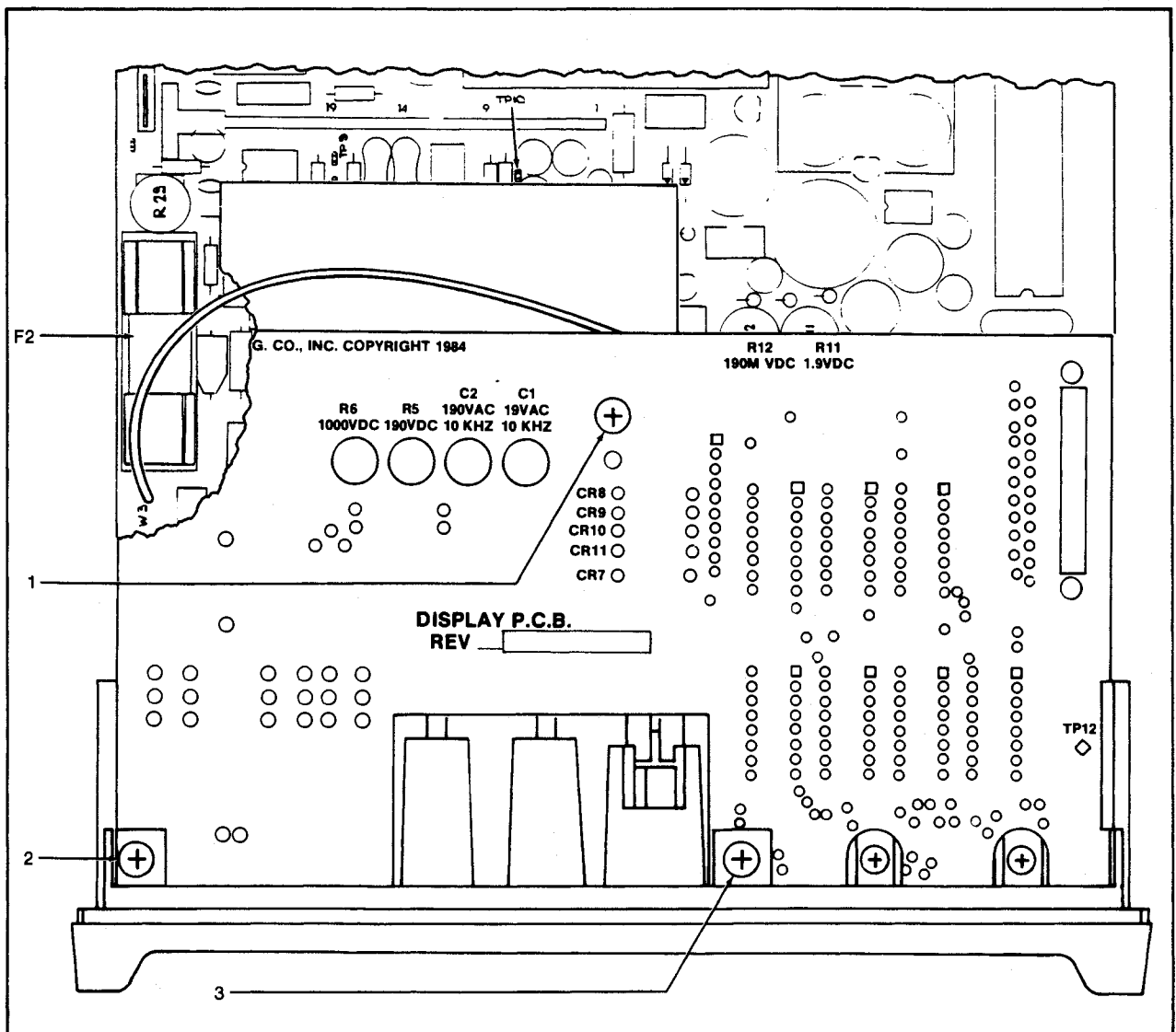

Figure 4-1. Display PCB Access

**MAINTENANCE
ACCESS PROCEDURES**

3. Using your fingernail, pry the grey tabs on the LCD bezel free from the screw posts and remove.
4. To reassemble, reverse the above procedures in a logical order.

4-19. BACKUP FUSE REPLACEMENT

4-20. Use the following procedure to replace the backup fuse (F2):

1. Complete the Calibration Access procedure.
2. Using a wide flat-blade screwdriver, pry the fuse out from the fuse holder. (Refer to Figure 4-1 for the location of F2.)
3. Replace the defective fuse a 3A, 600V fuse (mfg. part no. BBS-3).

4-21. AC LINE VOLTAGE SELECTION

4-22. The 8050A is configured at the factory for a specific ac line voltage. The configured ac line voltage is listed on a decal located on the bottom of the unit. Line voltage changes require the ordering of a new transformer for the instrument. Refer to the Main PCB Assembly parts list in Section 5 for the part number of the required transformer.

NOTE

Instruments with Option 8050A-01 Rechargeable Battery use a different procedure for changing the ac line voltage. Refer to Section 6 for this procedure.

4-23. Use the following procedure to change the ac line voltage configuration on the 8050A:

1. Complete the Calibration Access procedure.
2. Remove the transformer and replace it one for the intended line voltage.
3. Relocate the white wire (from the power receptacle) to the pcb hole labeled with the correct voltage.
4. Remove the case and relabel the ac line voltage designation on the decal at the bottom of the instrument.

4-24. dB Reference Impedance Power-Up Setting

4-25. The following procedure sets the default (at power up) dB reference impedance to any one of the 16 available impedances. In the standard configuration (no diodes installed), the default reference impedance is 600Ω.

1. Complete the Display PCB Access procedure.
2. Locate the diode mounting positions on the Display PCB Assembly (just to the right of the calibration access holes, viewed from the front of the instrument).
3. Refer to Table 4-2 and install diodes as shown for the desired reference impedance.
4. Reassemble the instrument.

Table 4-2. dB Impedance Selection

REFERENCE IMPEDANCE	CR8	CR9	CR10	CR11
50	-	⚡	⚡	-
75	-	⚡	⚡	⚡
93	⚡	-	-	-
110	⚡	-	-	⚡
125	⚡	-	⚡	-
135	⚡	-	⚡	⚡
150	⚡	⚡	-	-
250	⚡	⚡	-	⚡
300	⚡	⚡	⚡	-
500	⚡	⚡	⚡	⚡
600	-	-	-	-
800	-	-	-	⚡
900	-	-	⚡	-
1000	-	-	⚡	⚡
1200	-	⚡	-	-
8000	-	⚡	-	⚡

Diode Type: Use Fluke P/N 203323 (1N4448, 1N914 or equivalent)

4-26. Cleaning

CAUTION

Do not use aromatic hydrocarbons or chlorinated solvents for cleaning. These solutions will react with the plastic materials used in the instrument.

CAUTION

Do not allow the LCD to come in contact with moisture. Remove the LCD from the Display PCB Assembly before cleaning the pcb, and do not install the LCD until the pcb is completely dry.

4-27. Clean the front panel and case with a mild solution of detergent and water. Apply the solution with a soft cloth. Do not apply the solution directly to the front panel. Clean dust and debris from the pcb's with low-pressure (20 psi) dry air. Clean contaminants from the pcb's with isopropyl alcohol and a soft brush. Rinse with demineralized water while scrubbing with a soft brush. To dry the pcb's, remove any ICs in sockets and use low-pressure dry air, then bake at 50 to 60°C (124 to 140°F) for 24 hours. Replace any components removed for cleaning and reassemble the instrument.

4-28. PERFORMANCE TESTS

4-29. The performance tests are used to compare the 8050A performance with the list of specifications given in Section 1. We recommended that you run the performance tests for incoming inspection and periodic calibration. If the instrument fails any of the performance tests, then calibration adjustment and/or repair is needed.

4-30. Initial Procedures

4-31. Before beginning each of the tests, perform the following:

1. Remove all test leads.
2. Check the fuses and, if necessary, replace.
3. Set the POWER switch to ON, and allow the 8050A to stabilize for approximately 5 minutes. Conduct the tests in an environment with an ambient temperature of $23 \pm 5^\circ\text{C}$ ($73 \pm 9^\circ\text{F}$) and a relative humidity of less than 80%.

4-32. Display Test

4-33. Use the following procedure to verify the proper operation of the LCD:

1. Select the kΩ function, 200Ω range.

2. Verify that the overrange indicator (1) is displayed.
3. Connect the red test lead to the V/kΩ/S input connector and the black test lead to the COMMON input connector.
4. Refer to Table 4-3. Short the test leads together and verify that the display reads as shown for each of the resistance ranges.

Table 4-3. Display Test

SELECT RANGE	DISPLAY
200Ω	00.00*
2 kΩ	.0000*
20 kΩ	0.000
200 kΩ	00.00
2000 kΩ	000.0
20 MΩ	0.000

*Due to test lead resistance, the least significant digit(s) may fluctuate by several counts.

5. Select the DC V function, press the REF Z switch to the in position (on) and verify that four decimal points appear on the display.
6. Select the 200V dc range.
7. Connect the DMM Calibrator to the 8050A as follows: HI to the V/kΩ/S input connector and LO to the COMMON input connector.
8. Adjust the DMM Calibrator until the 8050A displays + 188.88V dc exactly.
9. Verify that all segments of the 8050A LCD are illuminated and the HV annunciator appears in the display.
10. Set the DMM Calibrator for a -39V dc output.
11. Verify that the HV annunciator disappears and the polarity indicator changes to - (negative).
12. Select the dB function on the 8050A, then set the RELATIVE switch to ON (in).
13. Verify that the dB and REL annunciators are illuminated.
14. This concludes the Display Test. Remove power from the DMM Calibrator before dismantling the test setup.

MAINTENANCE
LINEAR VOLTAGE TEST

4-34. Linear Voltage Test

4-35. Use the following procedure to verify the proper operation of the ac and dc voltage measurement functions:

1. Connect the DMM Calibrator to the 8050A as follows: HI to the V/k Ω /S input connector and LO to the COMMON input connector.
2. For each step in Table 4-4, select the switch positions shown and adjust the DMM Calibrator to the required 8050A voltage input level and frequency, then verify that the 8050A display reading is within limits.
3. This concludes the Linear Voltage Test. If desired proceed directly to the dB Voltage Test.

4-36. dB Voltage Test

4-37. Use the following procedure to verify the proper operation of the dB voltage measurement function:

1. Complete the Linear Voltage Test.
2. Select the AC dB function, 200mV range.
3. Connect the DMM Calibrator to the 8050A as follows: HI to the V/k Ω /S input connector and LO to the COMMON input connector.
4. For each step in Table 4-5, adjust the DMM Calibrator to the required 8050A voltage input level and frequency, then verify that the 8050A display reading is within limits.

Table 4-4. Linear Voltage Test

STEP	UUT SWITCH POSITIONS		UUT INPUT		DISPLAY READING		
	AC/DC	RANGE	LEVEL	FREQUENCY			
1	DC	200 mV	+190 mV dc		+189.92 to +190.08		
2			-190 mV dc		-189.92 to -190.08		
3		2V	+1.9V dc		+1.8992 to +1.9008		
4			-1.9V dc		-1.8992 to -1.9008		
5		20V	+19V dc		+18.992 to +19.008		
6		200V	+190V dc		+189.92 to +190.08		
7		1000V	+1000V dc		+999.5 to +1000.5		
8	AC	2V	Short		<.0040		
9		200 mV	190 mV ac rms	100 Hz	188.95 to 191.05		
10				10 kHz	188.95 to 191.05		
11				50 kHz	180.20 to 199.80		
12		2V	100 mV ac rms	100 Hz	985 to 1015		
13				100 Hz	1.9V ac rms	1.8895 to 1.9105	
14						10 kHz	1.8895 to 1.9105
15						50 kHz	1.8020 to 1.9980
16				20V	19V ac rms	100 Hz	18.895 to 19.105
17						10 kHz	18.895 to 19.105
18		50 kHz	18.020 to 19.980				
19		200V	190V ac rms	100 Hz	188.95 to 191.05		
20				10 kHz	99.40 to 100.60		
21				100 Hz	745.2 to 754.8		
22		750V	750V ac rms	1 kHz	745.2 to 754.8		

Table 4-5. dB Voltage Test

STEP	SELECT RANGE	INPUT		DISPLAY READING
		LEVEL	FREQUENCY	
1	200 mV dB	Short Circuit		Below -75 dB
2		10.00 mV ac rms	100 Hz	-37.28 to -38.28
3		10.00 mV ac rms	10 kHz	-37.28 to -38.28
4		1.0000V ac rms	100 Hz	+02.07 to +02.37

5. Disconnect the DMM Calibrator from the 8050A.
6. On the 8050A, set the POWER switch to OFF.
7. Set the REF Z switch to ON (in).
8. On the 8050A, set the POWER switch to ON and verify that the display reads 600 (the default reference impedance) for 3 seconds, then sequences through all stored reference values at a 1-second rate. Stored reference impedances are: 50, 75, 93, 110, 125, 135, 150, 250, 300, 500, 600, 800, 900, 1000, 1200, and 8(000).
5. Adjust the DMM Calibrator for an output 19.000 mA, at a frequency of 100Hz.
6. Verify that the display reads between 18.800 and 19.200.
7. This concludes the Current Test. Remove power from the DMM Calibrator before dismantling the test setup.

NOTE

If the default reference impedance of Step 8 is not 600, refer to the dB Reference Impedance Power Up Setting procedure and check if the default reference impedance has been changed.

9. This concludes the dB Voltage Test, remove power from the DMM Calibrator before dismantling the test setup.

4-38. Current Test

4-39. Use the following procedure to verify the proper operation of the ac and dc current measurement functions:

1. Select the DC mA function.
2. Connect the DMM Calibrator to the 8050A as follows: HI to the mA input connector and LO to the COMMON input connector.
3. For each step in Table 4-6, select the range shown and adjust the DMM Calibrator to the required 8050A current input, then verify that the 8050A display reading is within the limits.
4. Select the AC V function, 20mA range.

Table 4-6. Current Test

STEP	SELECT RANGE	INPUT	DISPLAY READING
1	200 μ A	190 μ A	189.41 to 190.59
2	2 mA	1.9 mA	1.8941 to 1.9059
3	20 mA	19 mA	18.941 to 19.059
4	200 mA	190 mA	189.41 to 190.59
5	2000 mA	1900 mA	1894.1 to 1905.9

4-40. Resistance and Conductance Tests

4-41. Use the following procedure to verify the proper operation of the resistance and conductance measurement functions:

1. Select the k Ω function, 200 Ω .
2. Connect the DMM Calibrator to the 8050A as follows: HI to the V/k Ω /S input connector and LO to the COMMON input connector.
3. For each step in Table 4-7, select the range shown and adjust the DMM Calibrator to the required 8050A resistance input, then verify that the 8050A display reading is within the limits.
4. This concludes the Resistance and Conductance Tests. Remove power from the DMM Calibrator before dismantling the test setup.

MAINTENANCE
LINEAR VOLTAGE TEST

Table 4-7. Resistance and Conductance Tests

STEP	SELECT RANGE	INPUT	DISPLAY READING
1	200Ω	Short	00.00 to 00.04
2	200Ω	100Ω	99.88 to 100.14
3	2 kΩ	1 kΩ	.9988 to 1.0012
4	20 kΩ	10 kΩ	9.993 to 10.007
5	200 kΩ	100 kΩ	99.93 to 100.07
6	2000 kΩ	1 MΩ	997.2 to 1002.8
7	20 MΩ	10 MΩ	9.972 to 10.028
8	2 mS	1 kΩ	.9985 to 1.0015
9	200 nS	10 MΩ	99.30 to 100.70

4-42. CALIBRATION ADJUSTMENTS

4-43. Under normal operating conditions the 8050A requires calibration once every year. Calibration adjustments are also required after the instrument has been repaired or if it fails any of the Performance Tests. Test equipment required for the adjustments is listed in Table 4-1. Figure 4-2 shows the location of all adjustments for the following procedures. For verification, do the Performance Tests after completing the Calibration Adjustments. If portions of the Calibration Adjustments cannot be completed, refer to the Jumper Selection procedures given later in this section.

NOTE

On the 8050A, set the POWER switch to ON and allow the instrument to stabilize for approximately 5 minutes. Perform the calibration adjustments at an ambient temperature of 23 ±5° C (79 ±9° F).

WARNING

CALIBRATION ADJUSTMENTS ARE PERFORMED ON ENERGIZED CIRCUITS. EXERCISE CAUTION AT ALL TIMES, AND USE A NON-CONDUCTIVE TOOL FOR ALL ADJUSTMENTS.

4-44. DC Calibration

4-45. Use the following procedure to perform a DC Calibration:

1. Connect the DMM Calibrator to the 8050A as follows: HI to the V/kΩ/S input connector and LO to the COMMON input connector.
2. Select the DC V function on the 8050A.
3. Turn on the DMM Calibrator.

4. For each step in Table 4-8, select the range shown, and adjust the DMM Calibrator for the required 8050A voltage input level, then adjust the indicated component to the display limits.
5. This concludes the DC Calibration Adjustment. Remove power from the DMM Calibrator before dismantling the test setup.

4-46. AC Calibration

4-47. Use the following procedure to perform an AC Calibration:

1. Connect the DMM Calibrator to the 8050A as follows: HI to the V/kΩ/S input connector and LO to the COMMON input connector.
2. Select the AC V function.
3. For each step in Table 4-9, select the range shown, and adjust the DMM Calibrator to the required 8050A voltage input level and frequency, then adjust the indicated component to the display limits.
4. This completes the AC Calibration procedure. Remove power from the DMM Calibrator before dismantling the test setup.

4-48. Jumper Selection

4-49. If the calibration adjustments do not bring the instrument within specifications or if certain critical components (VR1 or U32) have been replaced, complete one of the following jumper selection procedures. Jumper locations are shown in Figure 4-2.

4-50. U5 JUMPER SELECTION

4-51. The U5 jumper selection procedure should be performed if VR1 has been replaced or if R11 does not have a sufficient adjustment range. Use the following procedure to select the proper resistance for U5:

1. Using the 5-pin connector (p/n 537514) provided with the replacement parts kit, short MP20 jumper positions A-B-C-D.
2. On the 8050A, set the POWER switch to ON.
3. Adjust R11 fully counterclockwise.
4. Select DC V function, 2V range.
5. Connect the DMM Calibrator to the 8050A as follows: HI to the V/kΩ/S input connector and LO to the COMMON input connector.
6. Adjust the DMM Calibrator to +1.8888V dc.

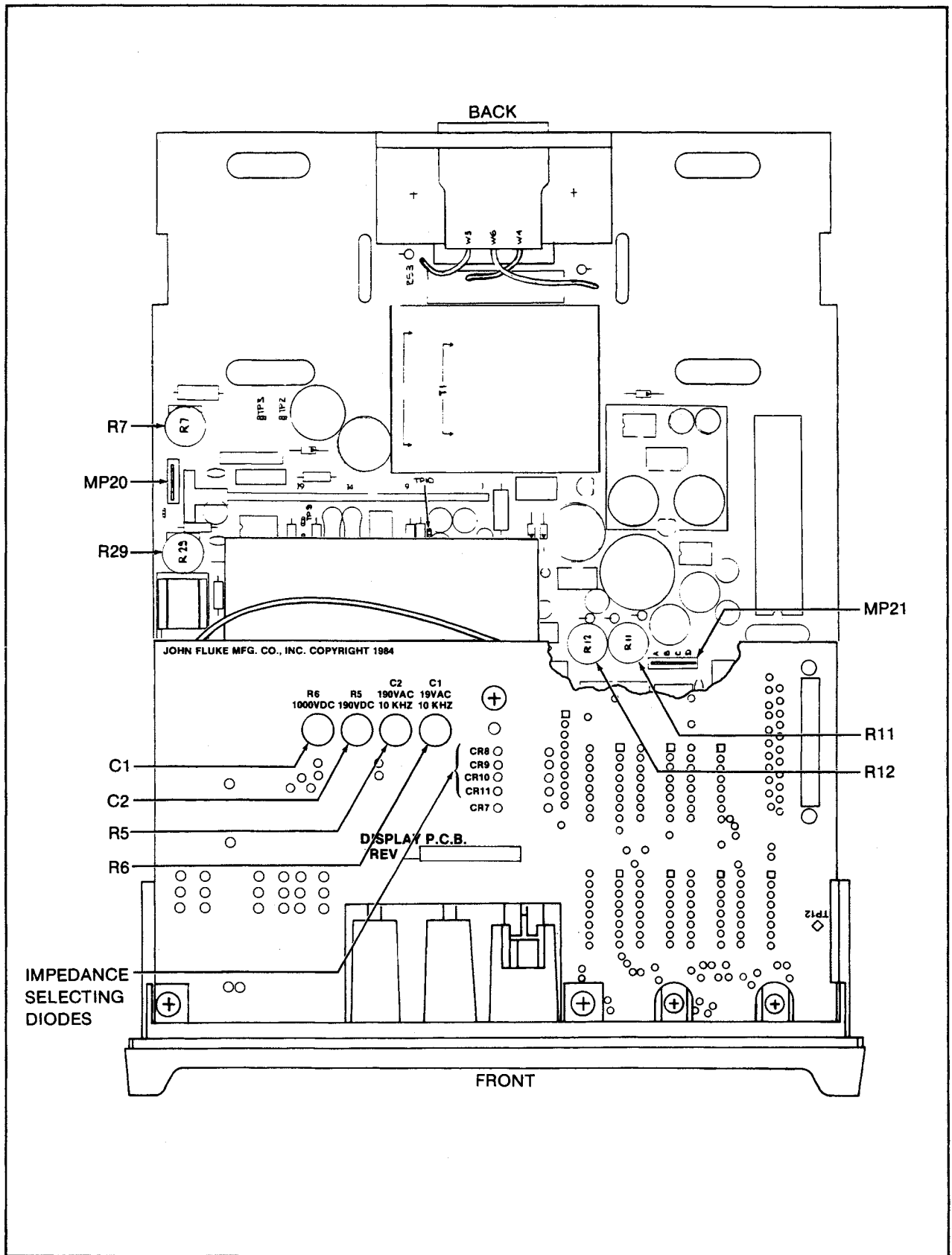



Figure 4-2. Calibration Adjustment Locations

**MAINTENANCE
CALIBRATION ADJUSTMENTS**

Table 4-8. DC Calibration

STEP	RANGE	VOLTAGE INPUT	ADJUST	DISPLAY LIMITS
1	2V	+1.9000V	R11	+1.9000 exactly 
2	200 mV	+190.00 mV	R12	+190.00 exactly
3	200 V	+190.00V	R5	+190.00 exactly
4	1000V dc	+1000.0V	R6	+1000.0 exactly







 If R11 can not be adjusted to the DISPLAY LIMIT, refer to the U5 jumper selection procedures in Section 4 of this manual.

Table 4-9. AC Calibration

STEP	RANGE	8050A VOLTAGE INPUT		ADJUST	DISPLAY LIMITS
		LEVEL	FREQ		
1	2V	1.9000V	200 Hz	R7	1.8995 to 1.9005 
2	2V	100.0 mV	200 Hz	R29	.0999 to .1001 
R7 and R29 are interacting adjustments. Repeat until both are within their limits.					
3	2V	Short circuit			Less than 40 digits 
4	20V	19.000V	10 kHz	C1*	18.990 to 19.010
5	200V	100.00V	10 kHz	C2*	99.95 to 100.05
C1 and C2 are interacting adjustments. Repeat until both are within their limits.					
*Use an insulated screwdriver for these adjustments.					

 If R7 cannot be adjusted to the DISPLAY LIMITS, refer to the U33 jumper selector procedure in Section 4 of this manual.

 If the display is not within limits in step 3 or R29 is outside adjustment range procedure range, refer to the RMS Converter Offset Adjustment procedure in Section 4 of this manual.

7. Turn on the DMM Calibrator.
8. Compare the 8050A display to the LOW and HIGH display readings in Table 4-10 and find the DISPLAY READING that the 8050A display is between. Cut out the portion of the jumper as shown under the JUMPER CONFIGURATION heading that corresponds to the DISPLAY READING.
9. Perform the Calibration Adjustments.
2. On the 8050A, set the POWER switch to ON.
3. Adjust R7 fully clockwise and adjust R29 the center of its range.
4. Select the AC V function, 2V range.
5. Connect the DMM Calibrator to the 8050A as follows: HI to the V/kΩ/S input connector and LO to the COMMON input connector.
6. Adjust the DMM Calibrator for 1.0000V ac rms, at 200Hz.
7. Turn on the DMM Calibrator.
8. Compare the 8050A display to the DISPLAY READING columns in Table 4-11 and find which LOW and HIGH values that the 8050A display reading is between. Cut out the portion of the jumper as shown under the JUMPER CONFIGURATION heading that corresponds to the DISPLAY READING.

4-52. U33 JUMPER SELECTION

4-53. The U33 jumper selection procedure should be performed if the RMS Converter (U32) has been replaced or if R7 does not have a sufficient adjustment range. Use the following procedure to select the proper resistance for U33:

1. Using the 4-pin connector (p/n 537522) provided with the replacement parts kit, short MP21 jumper positions E-F-G.

Table 4-10. U5 Jumper Positions

DISPLAY (ALL JUMPER PINS INSTALLED)		JUMPER CONFIGURATION AS VIEWED FROM REAR OF 8050A
LOW	HIGH	
1.8773	1.8879	
1.8667	1.8772	
1.8562	1.8666	
1.8459	1.8561	
1.8356	1.8458	
1.8255	1.8355	
1.8155	1.8254	
1.8056	1.8154	
1.7958	1.8055	
1.7861	1.7957	
1.7765	1.7860	
1.7670	1.7764	
1.7576	1.7669	
1.7483	1.7575	
1.7391	1.7482	
1.7300	1.7390	NO JUMPER INSTALLED

SELECTABLE JUMPER CONFIGURATION FOR DC CALIBRATION (VOLTAGE REFERENCE VR1 CALIBRATION NETWORK, U5).

9. Perform the Calibration Adjustments.
 - 4-54. RMS CONVERTER OFFSET ADJUSTMENT PROCEDURE
 - 4-55. The rms converter offset adjustment should be performed if R29 does not have a sufficient adjustment range or if the 8050A display reading is greater than .0040 in step 3 of Table 4-9. Use the following procedure to set the initial offset of the RMS Converter:
 1. On the 8050A, set the POWER switch to ON.
 2. Select the AC V function, 2V range.
 3. Connect the DMM Calibrator to the 8050A as follows: HI to the V/kΩ/S input connector and LO to the COMMON input connector.
 4. Adjust the DMM Calibrator for 1.0000V ac rms, at 400Hz.
 5. Turn on the DMM Calibrator.
 6. With the DMM, measure the voltage at pin 7 of the RMS Converter with reference to ground (TP1). This voltage must be 0.0V ± 20 mV. Record this voltage to the nearest 0.1 mV. If the

**MAINTENANCE
TROUBLESHOOTING**

measured voltage is beyond the limit, then replacement of the RMS Converter is indicated.

7. Measure the voltage at pin 6 of the RMS Converter. If this voltage is greater than ± 0.5 mV of the recorded value in step 5, adjust the potentiometer on the RMS Converter so that pin 6 is ± 0.2 mV of pin 7.
7. Perform the Calibration Adjustments.

4-57. TROUBLESHOOTING

CAUTION

The pcb assemblies used in the 8050A contain CMOS components which are static sensitive. Please read and comply with the information on the static awareness sheet given in the beginning of this section.

WARNING

DANGEROUS VOLTAGES EXIST ON PCB ASSEMBLIES EXPOSED FOR TROUBLESHOOTING. EXERCISE CAUTION WHEN MAKING MEASUREMENTS ON LIVE CIRCUITS, AND USE AN INSULATED TOOL FOR ALL ADJUSTMENTS. SET POWER TO OFF BEFORE REPLACING ANY COMPONENT OR DEVICE.

4-58. The following information is provided to help isolate faults and direct the technician to possible causes. Signal level or node description by test point is given in Table 4-12. A troubleshooting guide is presented in Table 4-13. This guide is intended to be used in conjunction with the Performance Tests. After completing the tests, note any discrepancies that have occurred, find the test heading in Table 4-13 and the apparent symptom, and use the possible cause as a starting point in troubleshooting the problem.

Table 4-11. U33 Jumper Positions

DISPLAY READING (All Jumper Pins Installed)		JUMPER CONFIGURATION, MP20 AS VIEWED FROM LEFT SIDE OF 8050A
LOW	HIGH	
1.0100	1.0497	<p>NO JUMPERS INSTALLED</p>
1.0498	1.0932	
1.0933	1.1366	
1.1367	1.1801	
1.1802	1.2236	
1.2237	1.2671	
1.2672	1.3106	
1.3107	1.3540	

JUMPER CONFIGURATION FOR AC CALIBRATION (RMS CONVERTER U32, CALIBRATION NETWORK, U33).

Table 4-12. Test Points

TEST POINT	FUNCTION	TEST POINT	FUNCTION
1	COMMON	8	A/D Converter Integrator Output
2	+13V	9	First AC Buffer Output
3 or CR 12 Cathode	+6 V	10	Second AC Buffer Output
4	-5V	11	RMS Converter Output
5	-10V	12	Display Back Plane Drive (50 Hz Square Wave)
6	A/D Converter Input	13	Integrate Control Line
7	A/D Converter Buffer Output		

**MAINTENANCE
TROUBLESHOOTING**

Table 4-13. Troubleshooting Guide

TEST AND SYMPTOM	POSSIBLE CAUSE
<p>INITIAL TURN ON Display Blank</p> <p>Display "stuck" with a constant reading</p> <p>Reads overload for several minutes after turn on</p>	<p>Power supply (Q6), power switch, interconnect, microcomputer U17</p> <p>Touch and Hold on, Q11, Q12</p> <p>Q17, Power On Reset (U17 pin 8)</p>
<p>DISPLAY TEST All segments on</p> <p>All or no decimal points</p> <p>Decimal point in wrong location</p> <p>1 or more digits missing</p> <p>1 or more annunciator missing</p>	<p>No drive (50 Hz squarewave, TP12) U10, interconnect, U17</p> <p>U16, U17, interconnect</p> <p>U16, range switch input to U17</p> <p>U10-16, interconnect, U17</p>
<p>LINEAR VOLTAGE TEST Display reading is out of tolerance</p> <p>Constant overrange in DC V</p> <p>Does not respond to input voltages</p> <p>Does not range properly in AC V</p>	<p>Out of calibration</p> <p>A/D, Check TP6, 7, and 8 for proper waveforms, U18, U19, U20</p> <p>R2 open, A/D input</p> <p>U17, U31, U22, Q7, Q8</p>
<p>dB VOLTAGE TEST Does not go into dB</p> <p>Does not autorange</p> <p>Display reading is out of tolerance</p>	<p>Function switch input to U17</p> <p>U17, U31, U22, Q7, Q8</p> <p>AC V is out of calibration</p>
<p>CURRENT TEST Does not respond to input currents</p> <p>Display reading is out of tolerance on 1 or more ranges</p>	<p>Fuse F1, F2</p> <p>R16, R17, R18, U6, U28, CR1</p>
<p>RESISTANCE/CONDUCTANCE TEST Reading is out of tolerance on 200Ω and 2 kΩ range</p> <p>Reading is out of tolerance on other ranges</p> <p>Readings are out of tolerance on high ohms</p> <p>Readings are noisy on all ranges</p> <p>Residual reading with test leads open</p>	<p>R3</p> <p>U1, check 190V dc calibration</p> <p>RV1, RV2, RV3 overheated from severe overload</p> <p>RT1, C39</p> <p>PCB is contaminated, see cleaning procedure in Section 4</p>

Section 5

List of Replaceable Parts

TABLE OF CONTENTS

ASSEMBLY NAME	DRAWING NO.	TABLE		FIGURE	
		NO.	PAGE	NO.	PAGE
Final Assembly	8050A-0&3	5-1	5-3	5-1	5-4
A1 Main PCB Assembly		5-2	5-5	5-2	5-9
Federal Supply Codes for Manufacturers		5-3	5-12	-	-
Fluke Technical Service Centers			5-13	-	-

LIST OF REPLACEABLE PARTS

5-1. INTRODUCTION

5-2. This section contains an illustrated listing of replaceable parts for the 8050A Digital Multimeter. Ordering procedures for parts and a cross-reference to federal supply codes are also provided in this section. Both mechanical and electrical components are listed by reference designators. Each assembly is accompanied by an illustration showing the part location and its reference designator.

5-3. PARTS ORDERING INFORMATION

5-4. Electrical components may be ordered directly from the manufacturer by using the manufacturer's part number, or from the John Fluke Mfg. Co., Inc. and its authorized representatives by using the part number under the heading FLUKE STOCK NO. Final assemblies are normally not available as a whole assembly.

5-5. To ensure prompt delivery of the correct part, include the following information.

1. Fluke Stock Number.
2. Description (as given under the DESCRIPTION heading).
3. Reference Designator.
4. Quantity.
5. Part Number and Revision Level of component's pcb.

5-6. Parts price information is available from the John Fluke Mfg. Co., Inc. or its representatives.

LIST OF REPLACEABLE PARTS

Table 5-1. 8050A Final Assembly

REF DES	DESCRIPTION	FLUKE STOCK NO.	MFG SPLY CODE	MFG PART NO.	TOT QTY	REC QTY	NO TE
	FINAL ASSEMBLY FIGURE 5-1 (8050A)	8050A	LINE	MODEL			
A1	MAIN PCB ASSEMBLY (LINE)				1		
F1	FUSE, FAST-ACT, 2A	376582	71400	AGX-2	1	5	
F2	FUSE, FIBRE, 3A, 600V	475004	71400	885-3	1	5	
H1	SCREW, PHP, 6-32 X 1/4	385401	73734	19042	7		
H2	SCREW, PHP, 6-32 X 1/2	320051	89536	320051	2		
H3	SCREW, RHP, 4-40 X 1/4	256156	89536	256156	5		
H4	SCREW, THD-FORMING, 5/20 X 5/16	494641	89536	494641	4		
H5	SCREW, SEMS, 6-32 X 1/4	178533	89536	178533	3		
H6	SCREW, PHP, 6/32 X 3/8	288266	89536	288266	2		
H7	WASHER, #6 FLAT	340505	89536	340505	2		
J1	CABLE, DISPLAY INTERCONNECT	507723	89536	507723	1		
LCD1	DISPLAY, LIQUID CRYSTAL	507673	89536	507673	1	1	
MP1	BEZEL, LCD	479642	89536	479642	1		
MP2	BRACKET, LCD	471730	89536	471730	1		
MP3	BUTTON, SWITCH (FUNCTION)	425900	89536	425900	4		
MP4	BUTTON, SWITCH (GREEN)	510271	89536	510271	1		
MP5	BUTTON, GRAY (OFFSET)	510164	89536	510164	1		
MP6	BUTTON, SWITCH (RANGE)	426759	89536	426759	6		
MP7	DECAL, CSA	525527	89536	525527	1		
MP8	CONNECTOR, ELASTOMERIC	453092	89536	453092	1		
MP9	FUSE HOLDER ASSEMBLY TO ORDER FUSE CAP ONLY, SEE MP12.	516039	89536	516039	1		
MP10	INSERT, SILICONE	525139	89536	525139	2		
MP11	INSULATOR	495044	89536	495044	1		
MP12	CAP, FUSE (FOR SEPARATE ORDER)	507699	89536	507699	1	1	
MP13	DECAL, DISC (ON HANDLE)	478248	89536	478248	2		
MP14	PANEL, FRONT	510156	89536	510156	1		
MP15	RECEPTACLE, AC	471029	89536	471029	1		
MP16	RETAINER, FLEX	510198	89536	510198	2		
MP17	SHIELD, INSULATOR	516021	89536	516021	1		
MP18	SHIELD, MAIN	510172	89536	510172	1		
MP19	SHIELD, TOP	510180	89536	510180	1		
MP20	INSULATOR, PCB	525196	89536	525196	1		
MP21	DECAL, FRONT PANEL	507657	89536	507657	1		
MP22	CASE, EXTERIOR PLASTIC	478008	89536	478008	1		
MP23	HANDLE, MOLDED PLASTIC	330092	89536	330092	1		
MP24	DECAL, SPECIFICATION	507665	89536	507665	1		
MP25	TEST LEAD W/PROBE (Y8132)	516666	89536	516666	1		
MP30	DECAL, FACTORY MUTUAL	524611	89536	524611	1		
MP31	JUMPER ASSY. (FOR U5)	537514	89536	537514	1	1	
MP32	JUMPER ASSY. (FOR U33)	537522	89536	537522	1	1	
MP33	BOX, UNIT SHIPMENT	697821	89536	697821	1		
MP34	BOX LINER	723155	89536	723155	1		
W1	LINE CORD	343723	89536	343723	1		
TM1	INSTRUCTION MANUAL (8050A)	530907	89536	530907	1		
	RECOMMENDED SPARE PARTS KIT (8050A)	533919	89536	533919	AR		

LIST OF REPLACEABLE PARTS

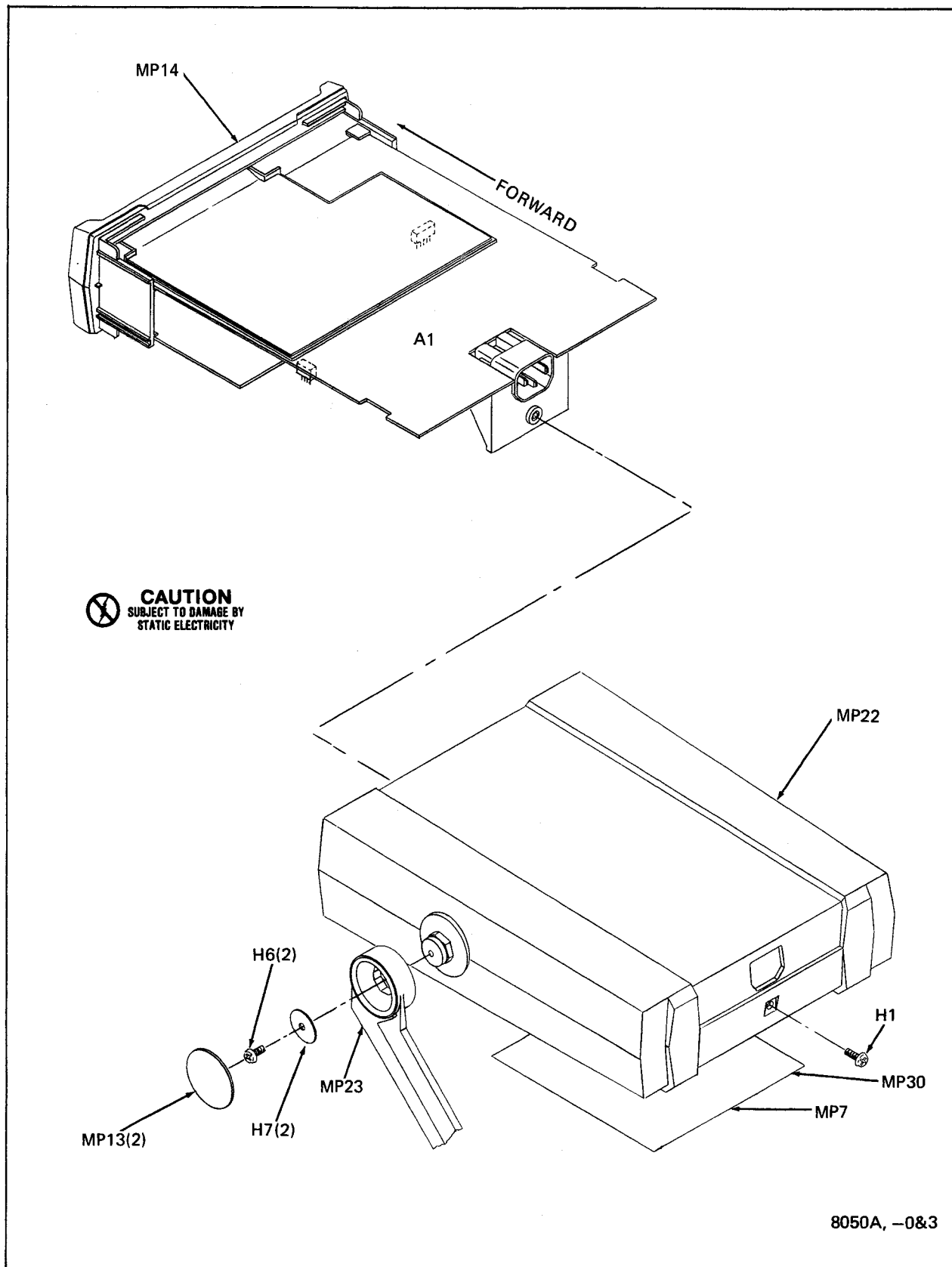
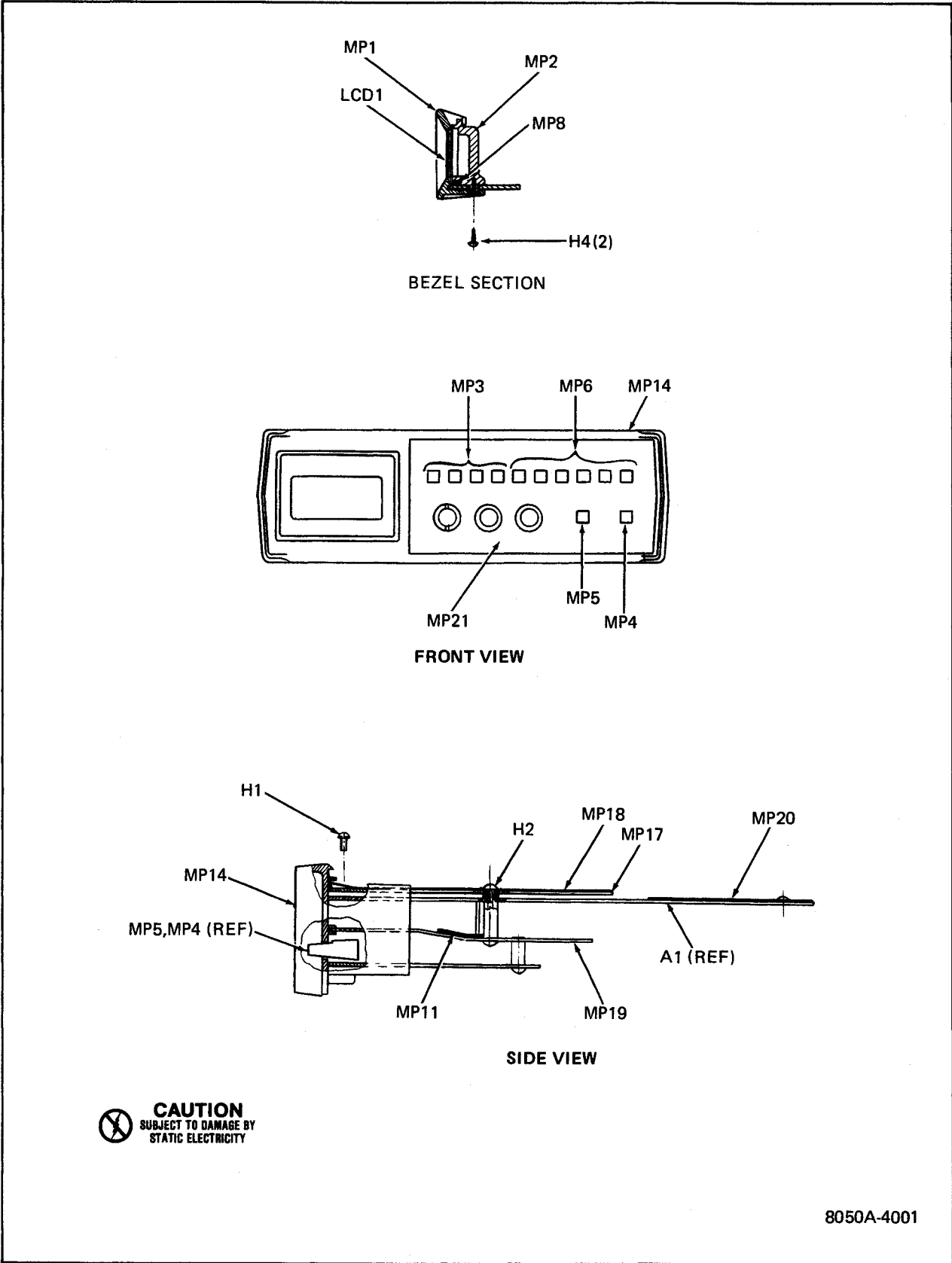

Figure 5-1. 8050A Final Assembly



CAUTION
SUBJECT TO DAMAGE BY
STATIC ELECTRICITY

8050A-4001

Figure 5-1. 8050A Final Assembly (cont)

LIST OF REPLACEABLE PARTS

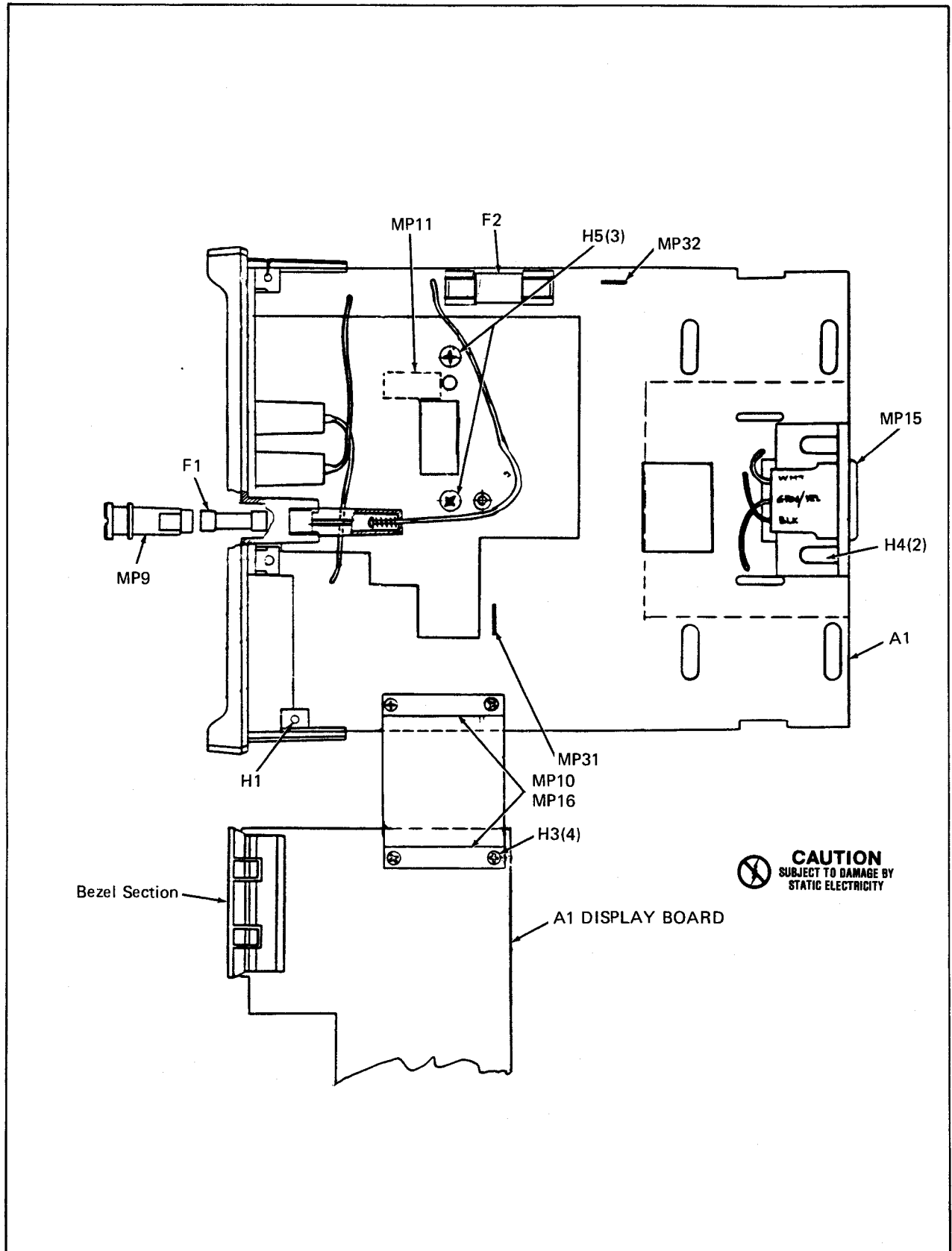

Figure 5-1. 8050A Final Assembly (cont)

LIST OF REPLACEABLE PARTS

Table 5-2. A1 Main PCB Assembly

REF DES	DESCRIPTION	FLUKE STOCK NO.	MFG SPLY CODE	MFG PART NO.	TOT QTY	REC QTY	NOTE
A1	MAIN PCB ASSEMBLY FIGURE 5-2 (8050A-4001AA1)		LINE	MODEL			1 2
C1	CAP, VAR, 1-5-0.25 PF, 2000V	218206	72982	530-000	2		
C2	CAP, VAR, 1-5-0.25 PF, 2000V	218206	72982	530-000	REF		
C3	CAP, MICA, 120 PF +/-5%, 500V	148486	72136	DM15F121J	2		
C4	CAP, MICA, 120 PF +/-5%, 500V	148486	72136	DM15F121J	REF		
C5	CAP, MICA, 1800 PF +/-5%, 500V	148353	89536	148353	1		
C6	CAP, POLYPROP, 10 UF +/-10%, 100V	446781	89536	446781	1		
C7	CAP, POLYEST, 1.0 UF +/-10%, 100V	447847	37445	C280MAH/AIM	1		
C8	CAP, TA, 10 UF +/-20%, 15V	193623	56289	196D106X0015A1	4		
C9	CAP, POLYPROP, .22 UF +/-10%, 100V	446799	89536	446799	1		
C10	CAP, POLYESTER, .022 UF +/-10%, 1000V	448183	52763	MKT. 1822 322/10	1		
C11	CAP, NYLAR, .047 UF +/-10%, 250V	162008	73445	C280MAE/A47K	2		
C12	CAP, ELECT, 470 UF -10/+75%, 16V	501510	89536	501510	2		
C13	CAP, ELECT, 470 UF -10/+75%, 16V	501510	89536	501510	REF		
C14	CAP, TA, 10 UF +/-20%, 15V	193623	56289	196D106X0015A1	REF		
C15	CAP, TA, 22 UF +/-20%, 15V	423012	56289	196D226X0015KA1	1		
C16	CAP, ELECT, 220 UF -10/+75%, 25V	484071	89536	484071	2		
C17	CAP, ELECT, 220 UF -10/+75%, 25V	484071	89536	484071	REF		
C18	CAP, ELECT, 22 UF -10/+75%, 16V	436840	89536	436840	2		
C19	CAP, ELECT, 22 UF -10/+75%, 16V	436840	89536	436840	REF		
C25	CAP, CER, 1000 PF +/-20%, 100V	149153	56289	C0238101F103M	3		
C26	CAP, CER, 1000 PF +/-20%, 100V	149153	56289	C0238101F103M	REF		
C27	CAP, TA, 2.2 UF +/-20%, 20V	161927	56289	196D226X0020HA1	1		
C28	CAP, POLYPROP, .047 UF +/-10%, 100V	446773	89536	446773	1		
C29	CAP, MICA, 180 PF +/-5%, 500V	148460	72136	DM15F181J	1		
C30	CAP, MICA, 68 PF +/-5%, 500V	148510	72136	DM15F680J	1		
C31	CAP, NYLAR, .047 UF +/-10%, 250V	162008	73445	C280MAE/A47K	REF		
C32	CAP, CERAMIC, 1000 PF +/-10%, 500V	357806	56289	C0168102G-102K	3		
C33	CAP, TA, 10 UF +/-20%, 15V	193623	56289	196D106X0015A1	REF		
C35	CAP, CERAMIC, 1000 PF +/-10%, 500V	357806	56289	C0168102G-102K	REF		
C36	CAP, CERAMIC, 1000 PF +/-10%, 500V	357806	56289	C0168102G-102K	REF		
C37	CAP, CER, .025 UF +/-20%, 100V	168435	56289	C0238101H253M	1		
C38	CAP, ELECT, 47 UF +/-20%, 10V	613984	89536	613984	2		
C39	CAP, ELECT, 47 UF +/-20%, 10V	613984	89536	613984	REF		
C40	CAP, MICA, 330 PF +/-5%, 500V	148445	72136	DM15F331J	1		
C41	CAP, ELECT, 10 UF +/-20%, 16V	614859	89536	614859	2		
C42	CAP, TA, 10 UF +/-20%, 15V	193623	56289	196D106X0015A1	REF		
C43	CAP, CER, 1000 PF +/-20%, 100V	149153	56289	C0238101F103M	REF		
C44	CAP, ELECT, 10 UF +/-20%, 16V	614859	89536	614859	REF		
CL1	DIODE, FED, CURRENT REGULATOR	393454	07910	TCR5290	1		1
CR1	DIODE, SI, RECTIFIER, 2 AMP, 50 VOLT	347559	14099	1N5400	1		1
CR2	DIODE, SI, LO-CAP/LO-LEAK	348177	07263	FD7223	3		1
CR3	DIODE, SI, LO-CAP/LO-LEAK	348177	07263	FD7223	REF		
CR12	DIODE, SI, LO-CAP/LO-LEAK	348177	07263	FD7223	REF		
MP1	SPRING, COMPRESSION COIL	422824	83553	C0240-026-0500-S	1		
MP2	SUPPORT, HYBRID (TO U32)	515635	89536	515635	2		
MP6	SUPPORT, RESISTOR	545079	89536	545079	1		
MP7	CLIP, COMPONENT	516880	89536	516880	2		
MP8	SPACER, SWAGED	525154	89536	525154	4		
MP9	SPACER, STANDOFF	295089	89536	295089	2		
Q1	XSTR, SI, NPN	218396	89536	218396	3		1
Q2	XSTR, SI, NPN	218396	89536	218396	REF		
Q3	XSTR, SI, NPN (METAL)	329698	89536	329698	1		1
Q4	XSTR, SI, PNP	225599	07263	2N4250	2		1
Q7	XSTR, FIELD EFFECT (FET)	370072	89536	370072	2		1
Q8	XSTR, FIELD EFFECT (FET)	370072	89536	370072	REF		
Q11	XSTR, SI, PNP	195974	04713	2N3906	1		1
Q12	XSTR, SI, NPN	168716	07263	519254	1		1
Q14	XSTR, SI, PNP (SELECTED)	380394	89536	380394	3		1
Q15	XSTR, SI, PNP (SELECTED)	380394	89536	380394	REF		
Q16	XSTR, SI, PNP	225599	07263	2N4250	REF		
Q17	XSTR, SI, PNP (SELECTED)	380394	89536	380394	REF		
Q18	XSTR, SI, NPN	218396	89536	218396	REF		

LIST OF REPLACEABLE PARTS

Table 5-2. A1 Main PCB Assembly (cont)

REF DES	DESCRIPTION	FLUKE STOCK NO.	MFG SPLY CODE	MFG PART NO.	TOT QTY	REC QTY	NOTE
Q19	XSTR, FET, DUAL N-CHANNEL	419283	89536	419283	1	1	
R1	RES, COMP, 100K +/-10%, 1W	109397	01121	G81041	1		
R2	RES, WJ, 1000 +/-10%, 2W	474080	89536	474080	1		
R3	RES, HTL, FILM, 1000 +/-5%, 1/10W	514245	89536	514245	1		
R5	RES, CER, 100K +/-10%, 1/2W	529099	89536	529099	1		
R6	RES, VAR, 100 +/-10%, 1/2W	529115	89536	529115	1		
R7	RES, VAR, CER, 1K +/-10%, 1/2W	513259	89536	513259	1		
R8	RES, COMP, 220K +/-10%, 2W	110197	01121	HB1011	1		
R11	RES, VAR, CER, 500 +/-10%, 1/2W	447730	89536	447730	1		
R12	RES, CERMET, 200 +/-10%, 1/2W	474973	89536	474973	1		
R14	RES, DEP. CAR, 1M +/-5%, 1/4W	348987	80031	CR251-4-5P1M	4		
R15	RES, DEP. CAR, 20 +/-5%, 1/4W	442202	80031	CR251-4-5P20E	1		
R16	RES, HTL, FILM, 900 +/-0.1%, 1/8W	461988	91637	CMF55901	1		
R17	RES, HTL, FILM 90 +/-0.1%, 1/8W	461970	91637	CMF55902	1		
R18	RES, WJ, 9 +/-15%, 1W	461962	89536	461962	1		
R19	RES, COMP, 100K +/-5%, 2W	285056	89536	285056	1		
R20	RES, COMP, 2.2M +/-10%, 1/2W	108225	89536	285056	1		
R21	RES, COMP, 22M +/-5%, 1/4W	221986	01121	CB2265	1		
R22	RES, DEP. CAR, 100 +/-5%, 1/4W	348771	80031	CR251-4-5P100E	3		
R23	RES, DEP. CAR, 100 +/-5%, 1/4W	348771	80031	CR251-4-5P100E	REF		
R24	RES, COMP, 4.7M +/-5%, 1/4W	220046	01121	CB4755	4		
R29	RES, VAR, 1M +/-10%, 1/2W	485052	89536	485052	1		
R30	RES, DEP. CAR, 470K +/-5%, 1/4W	342634	80031	CR251-4-5P470K	1		
R32	RES, DEP. CAR, 1M +/-5%, 1/4W	348987	80031	CR251-4-5P1M	REF		
R33	RES, DEP. CAR, 1M +/-5%, 1/4W	348987	80031	CR251-4-5P1M	REF		
R36	RES, DEP. CAR, 15K +/-5%, 1/4W	348854	80031	CR251-4-5P15K	1		
R37	RES, COMP, 4.7M +/-5%, 1/4W	220046	01121	CB4755	REF		
R38	RES, DEP. CAR, 15K +/-5%, 1/4W	348854	80031	CR251-4-5P15K	REF		
R39	RES, HTL, FILM, 232K +/-1%, 1/8W	276618	91637	CMF552323	1		
R40	RES, DEP. CAR, 680 +/-5%, 1/4W	368779	80031	CR2510405P680E	1		
R42	RES, DEP. CAR, 27K +/-5%, 1/4W	441501	80031	CR251-4-5P27K	1		
R43	RES, DEP. CAR, 750K +/-5%, 1/8W	442525	80031	CR251-4-5P750K	1		
R44	RES, DEP. CAR, 100 +/-5%, 1/4W	348771	80031	CR251-4-5P100E	REF		
R45	RES, COMP, 4.7M +/-5%, 1/4W	220046	01121	CB4755	REF		
R46	RES, FXD, 24K +/-5%, 1/4W	442384	80031	CR251-4-5P24K	1		
R48	RES, DEP. CAR, 15K +/-5%, 1/4W	348854	80031	CR251-4-5P15K	REF		
R49	RES, DEP. CAR, 27K +/-5%, 1/4W	441501	80031	CR251-4-5P27K	1		
R52	RES, COMP, 47M +/-10%, 1/2W	146415	89536	146415	1		
R53	RES, COMP, 4.7M +/-5%, 1/4W	220046	01121	CB4755	REF		
R54	RES, DEP. CAR, 1M +/-5%, 1/4W	348987	80031	CR251-4-5P1M	REF		
R55	RES, DEP. CAR, 470K +/-5%, 1/4W	342634	80031	CR251-4-5P470K	1		
R56	RES, CAR, DEP, 1 +/-5%, 1/4W	357665	80031	CR251-4-5P1E	1		
RT1	THERMISTOR	446849	50157	180Q10200	1		1
RV1	VARISTOR	447672	09214	V430MA7	3		3
RV2	VARISTOR	447672	09214	V430MA7	REF		
RV3	VARISTOR	447672	09214	V430MA7	REF		
S1-S10	SWITCH ASSEMBLY	507707	89536	507707	1		
S11	SWITCH	473736	89536	473736	2		
S12	SWITCH	473736	89536	473736	REF		
T1	TRANSFORMER, POWER	ORDER	FUR	APPROPRIATE VOLTAGE	1		
	120V	512939	89536	512939			
	100V	513283	89536	513283			
	240V	513291	89536	513291			
	115V, 60Hz	512939	89536	512939			
TP1-5	TERMINAL PINS	379438	89536	379438	12		
TP7-13							
U1	RESISTOR NETWORK	501080	89536	501080	1		3
U2	RESISTOR NETWORK	512905	89536	512905	1		4
U3	RESISTOR NETWORK	513556	89536	513556	1		1
U4	RESISTOR NETWORK	513580	89536	513580	1		1
U5	RESISTOR NETWORK	519736	89536	519736	1		1
U6	IC, RES, 2-RESISTOR SHUNT	461491	89536	461491	1		1
U7	IC, OP-AMP, DUAL, COMPENSATED, 8-PIN DIP	418566	18324	LM359N/CR3999	2		1
U8	IC, OP-AMP, DUAL, COMPENSATED, 8-PIN DIP	418566	18324	LM359N/CR3999	REF		

LIST OF REPLACEABLE PARTS

Table 5-2. A1 Main PCB Assembly (cont)

REF DES	DESCRIPTION	FLUKE STOCK NO.	MFG SPLY CODE	MFG PART NO.	TOT QTY	REC QTY	NOTE
U9	IC, LOW POWER, DUAL VOLTAGE COMPARATOR	478354	01295	LM393N	2	1	
U10	IC, C-MOS, LIQUID-CRYSTAL 4-SEGMENT	453225	02735	CD4054BE	3	1	
U11	IC, C-MOS, LIQUID-CRYSTAL 4-SEGMENT	453225	02735	CD4054BE	REF		
U12	IC, C-MOS, LIQUID-CRYSTAL DSPLY DRIVERS	507376	02735	CD4056BE	4	1	
U13	IC, C-MOS, LIQUID-CRYSTAL DSPLY DRIVERS	507376	02735	CD4056BE	REF		
U14	IC, C-MOS, LIQUID-CRYSTAL DSPLY DRIVERS	507376	02735	CD4056BE	REF		
U15	IC, C-MOS, LIQUID-CRYSTAL DSPLY DRIVERS	507376	02735	CD4056BE	REF		
U16	IC, C-MOS, LIQUID-CRYSTAL 4-SEGMENT	453225	02735	CD4054BE	REF		
U17	IC, C-MOS, SI, N-CHANNEL, 40 PIN DIP	524900	89536	524900	1	1	
U18	IC, SELECTED (8050A-4506)	515999	89536	515999	1	1	
U19	IC, SELECTED (8050A-4506-01)	516005	89536	516005	2	1	
U20	IC, SELECTED (8050A-4506-01)	516005	89536	516005	REF		
U21	IC, OPERATIONAL AMP. (8050A-4504)	609883	89536	609883	2	1	
U22	IC, C-MOS, QUAD BILATERAL SWITCH, 14-PIN	343838	12040	MS5616AM	1	1	
U23	IC, OPERATIONAL AMP. (8050A-4504)	609883	89536	609883	REF		
U24	VOLTAGE REGULATOR	507434	89536	507434	1	1	
U25	VOLTAGE REGULATOR	507442	89536	507442	1	1	
U27	RESISTOR NETWORK	513598	89536	513598	1	1	
U28	RECTIFIER BRIDGE	418582	83003	VM08	2	1	
U29	RECTIFIER BRIDGE	418582	83003	VM08	REF		
U31	IC, LOW POWER, DUAL VOLTAGE COMPARATOR	478354	01295	LM393N	REF		
U32	HYBRID RMS TO DC CONVERTER	510685	89536	510685	1		
U33	RESISTOR NETWORK	513564	89536	513564	1	1	
U34	RESISTOR NETWORK	519728	89536	519728	1	1	
VR1	DIODE, ZENER	387217	89536	387217	1	1	
W1	WIRE ASSEMBLY (RED)	537159	89536	537159	1		
W2	WIRE ASSEMBLY (BLK)	537167	89536	537167	1		
W3	WIRE ASSEMBLY (WHT)	489096	89536	489096	1		
W4	WIRE ASSEMBLY (BLK)	489104	89536	489104	1		
W5	WIRE ASSEMBLY (WHT)	489120	89536	489120	1		
W6	WIRE ASSEMBLY (GRN, YEL)	489112	89536	489112	1		
XU17	SOCKET, IC	429282	09922	DILB40P-108	1		
XU18-20	SOCKET, 14-PIN	276527	09922	DILB8P-108	3		
Y1	CRYSTAL, 4 MHZ	474072	89536	474072	1		
	1	Please be aware of voltage changes.					
	2	Certain components may not be used therefore may not be installed.					
	3	U1 P/N 510941 may be used in place of P/N 501080					
	4	U2 P/N 510834 may be used in place of P/N 512905.					

LIST OF REPLACEABLE PARTS

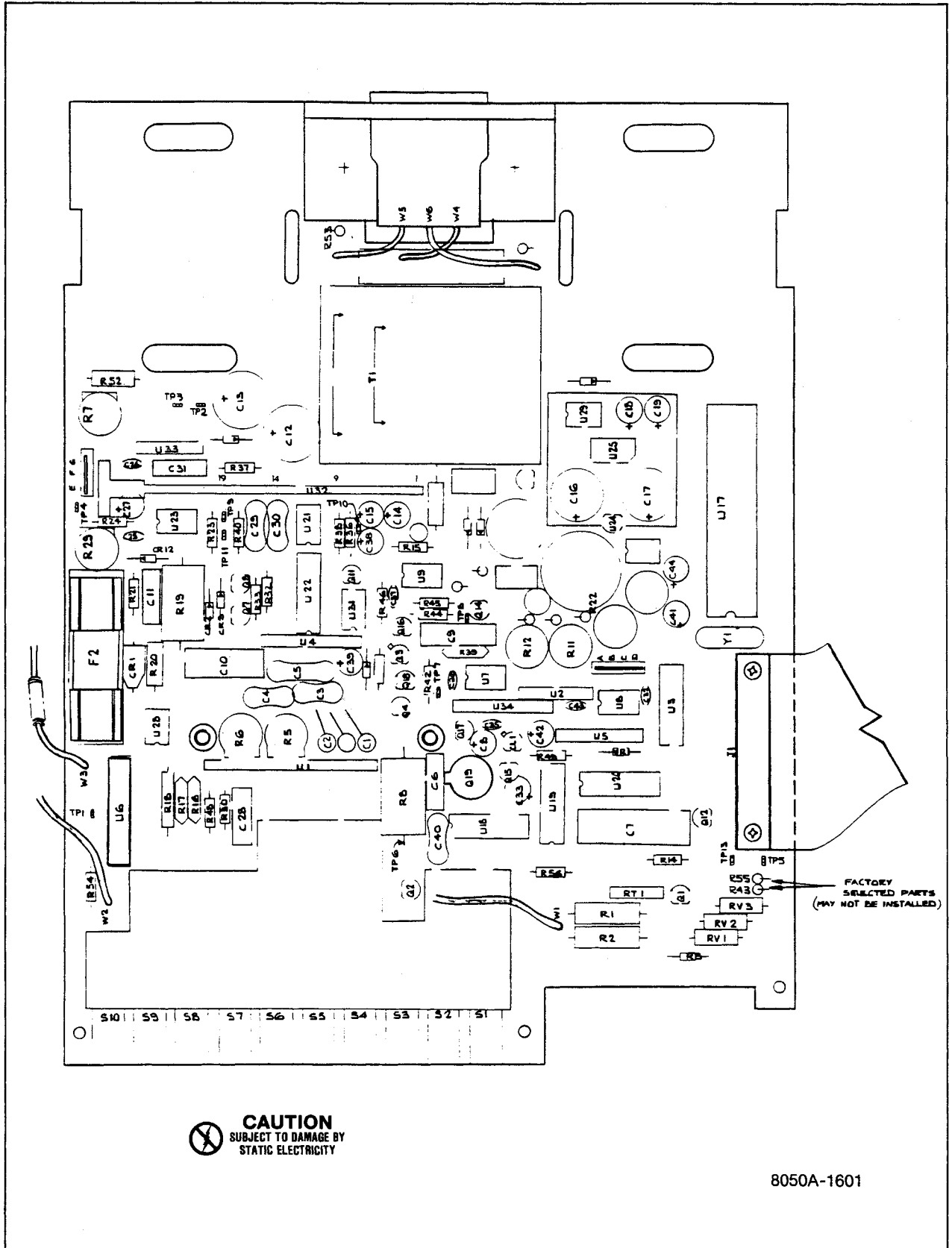
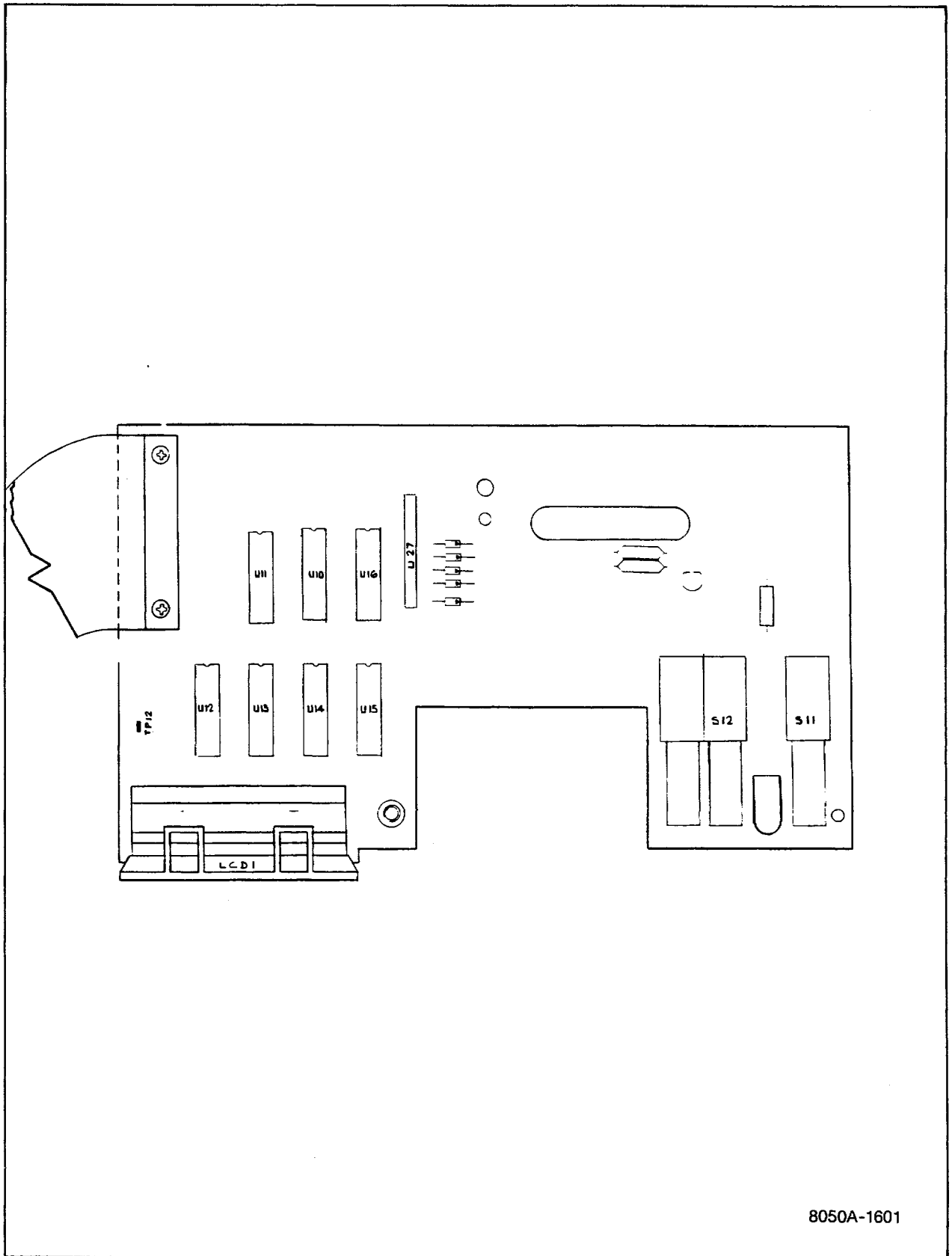

Figure 5-2. 8050A A1 Main PCB Assembly



8050A-1601

Figure 5-2. 8050A A1 Main PCB Assembly (cont)

Table 5-3. Federal Supply Codes for Manufacturers

01121	Allen-Bradley Co. Milwaukee, Wisconsin	12040	National Semiconductor Corp. Danbury, Connecticut	72982	Erie Tech. Products, Inc. Erie, Pennsylvania
01295	Texas Instruments, Inc. Semiconductor Components Div. Dallas, Texas	14099	Semtech Corp. Newbury Park, California	73445	Amperex Electronic Corp. Hicksville, New York
02735	RCA Corp. Solid State Div. Somerville, New Jersey	18324	Signetics Corp. Sunnyvale, California	73734	Federal Screw Products, Inc. Chicago, Illinois
04713	Motorola Semiconductor Products, Inc. Phoenix, Arizona	30035	Jolo Industries, Inc. Garden Grove, California	78189	Shakeproof Div. of Illinois Tool Works Elgin, Illinois
07263	Fairchild Semiconductor Div. of Fairchild Camera & Instrument Corp. Mountain View, California	50157	Midwest Components, Inc. Muskegon, Michigan	80031	Mepco Div. of Sessions Clock Co. Morristown, New Jersey
07910	Teledyne Corp. (Continental Device) Hawthorne, California	52072	Circuit Assembly Corp. Costa Mesa, California	83003	Varo, Inc. Garland, Texas
09214	G.E. Semi-Conductor Products Dept. Auburn, New York	52763	Stettner-Trush, Inc. Cazenovia, New York	83553	Associated Spring Barnes Group, Inc. Gardena, California
09922	Burndy Corp. Norwalk, Connecticut	53217	Technical Wire Products, Inc. Santa Barbara, California	89536	Fluke, John Mfg. Co., Inc. Seattle, Washington
11503	Keystone Mfg. Div. of Avis Industrial Corp. Warren, Michigan	56289	Sprague Electric Co. North Adams, Massachusetts	91502	Associated Machine Santa Clara, California
		71400	Bussmann Mfg. Div. of McGray - Edison Co. Saint Louis, Missouri	91637	Dale Electronics, Inc. Columbus, Nebraska
		72136	Electro Motive Mfg. Co. Williamantic, Connecticut		

TECHNICAL SERVICE CENTERS

U.S. & Canada

CA, Burbank

Fluke Technical Center
2020 N. Lincoln Street
Burbank, CA 91504
(213) 849-4641

CA, Santa Clara

Fluke Technical Center
2300 Walsh Ave., Bldg. K
Santa Clara, CA 95050
(408) 727-8121

CO, Denver

Fluke Technical Center
1980 S. Quebec St., Unit 4
Denver, CO 80231
(303) 750-1228

FL, Orlando

Fluke Technical Center
940 N. Fern Creek Avenue
Orlando, FL 32803
(305) 896-2296

IL, Rolling Meadows

Fluke Technical Center
1400 Hicks Road
Rolling Meadows, IL 60008
(312) 398-5800

MA, Burlington

Fluke Technical Center
25 "B" Street
Burlington, MA 01803
(617) 273-4678

MD, Rockville

Fluke Technical Center
5640 Fishers Lane
Rockville, MD 20852
(301) 770-1576

NJ, Paramus

Fluke Technical Center
West 75th Century Road
Paramus, NJ 07652
(201) 262-9550

TX, Dallas

Fluke Technical Center
14400 Midway Road
Dallas, TX 75240
(214) 233-9945

WA, Everett

Fluke Technical Center
6920 Seaway Blvd.
Everett, WA 98206
(206) 356-5560

ALB, Calgary

Allan Crawford Assoc., Ltd.
#14 1935 30th Ave. N.E.
Calgary, Alberta T2E 6Z5
(403) 230-1341

ONT, Mississauga

Allan Crawford Assoc., Ltd.
6503 Northam Drive
Mississauga, Ontario L4V 1J2
(416) 678-1500

QUE, Montreal

Allan Crawford Assoc., Ltd.
7018 Cote de Liesse
Montreal, Quebec H4T 1E7
(514) 731-8564

B.C., Burnaby

Allan Crawford Assoc. Ltd.
3795 William St.
Burnaby, B.C. V5C 3H3
(604) 294-1326

Other Areas

Argentina

Coasin S.A.
Virrey del Pino 4071
Buenos Aires, Argentina
Tel: 522-5248

Australia

Elmeasco Instruments Pty Ltd.
P.O. Box 30
Concord, N.S.W.
Australia 2137
Tel: (02) 736-2888

Australia

Elmeasco Instruments Pty. Ltd.
P.O. Box 107
Mr. Waverly, VIC 3149
Australia
Tel: (03) 2334044

Australia

Elmeasco Instruments Pty. Ltd.
GPO Box 2360
Brisbane, Queensland 4001
Australia
Tel: (07) 229-3161

Austria

Walter Rekirsch
Elektronische Gerate GmbH & Co.
Vertriebs-KG., Obachgasse 28
A-1220 Vienna, Austria
Tel: (0222) 235555

Belgium

Fluke (Belgium) S.A./N.V.
6, Rue de Geneve
1140 Brussels, Belgium
Tel: 09-32-2-2164090

Brazil

Fluke Brasil-Industria e Comercio Ltda.
Al. Amazonas 422, Alphaville, Barueri
CEP 06400 Sao Paulo, Brazil
Tel: (011) 421-3603

Chile

Intronica Chile Ltda.
Casilla 16228
Santiago 9, Chile
Tel: 44940

China, Peoples Republic of

Beijing Radio Research Institute
Dianmen East Avenue 89
Beijing, China
Tel: 445612

Colombia

Sistemas E Instrumentacion, Ltda.
Carrera 13, No. 37-43, Of. 401
Ap. Aero 29583
Bogota DE, Colombia S.A.
Tel: 232-45-32

Denmark

Tage Olson A/S
Ballerup Byvej 222
DK-2750 Ballerup
Denmark
Tel: 09-45-2-658111

Ecuador

Proteco Coasin Cia., Ltda.
Edificio "Jerico"
Ave. 12 de Octubre #2285 y
Ave. Orellana (Planta Baja)
Quito, Ecuador
Tel: 526759

Egypt and Sudan

Electronic Engineering Liaison Office
11 Ahmed Khashaba Street
Hegas Square
Heliopolis, Cairo, Egypt
Tel: 691588

Finland

Oy Findip AB
Teollisuustie 7
02700 Kauniainen
Finland
Tel: 09-358-0-502255

France

M.B. Electronique S.A.
Rue Fourny
ZAC de BUC
B.P. No. 31
78530 BUC, France
Tel: 09-33-1-9568131

Greece

Hellenic Scientific
Representations Ltd.
11, Vrassida Street
Athens 612, Greece
Tel: 09-30-1-711140

Hong Kong

Schmidt & Co (H.K.) Ltd.
28th Fl. Wing On Centre
111 Connaught Road
Central Hong Kong
Tel: 5-455644

India

Hinditron Services Pvt. Ltd.
Field Service Centre
8th Main Road
33/44-A Raj Mahal Vilas Extn.
Bangalore 560 080, India
Tel: 33139

India

Hinditron Services Pvt. Ltd.
69/A.L. Jagmohandas Marg
Bombay 400 006, India
Tel: 811316

India

Hinditron Services Pvt. Ltd.
15, Community Centre
Panchshila Park
New Delhi, India 110-017
Tel: 619118

Israel

R.D.T. Electronics Engineering Ltd.
P.O. Box 75
46, Sokolov Street
Ramat Hasharon 47235
Israel
Tel: 09-972-3-483211

Italy

Sistrel S.p.A.
Via Pelizza da Volpedo 59
20092 Cinisello Besamo
Milan, Italy
Tel: (2) 6181893

Italy

Sistrel S.p.A.
Via Giuseppe Armellini No. 37
00143 Rome, Italy
Tel: 09-39-6-5915551

Japan

John Fluke Mfg. Co., Inc.
Japan Branch
1 Higashikata-machi
Midori-ku
Yokohama 226, Japan
Tel: (045) 473-5428

Korea

Electro-Science Korea Co.
C.P.O. Box 8446
Room 201, Boondo Bldg.
56-12, Gangchung-1 Ka
Gung-Ku
Seoul, Korea
Tel: 261-7702

Malaysia

Rank O'Connor's (Malaysia) SDN. BHD.
P.O. Box 91
Petaling Jaya, Selangor
West Malaysia
Tel: 566599

Mexico

Christensen S.A.
Guillermo Prieto 76-304
Col. San Rafael
Delegacion Cuahutemec
06470-Mexico, D.F.
Tel: 546-25-95

Netherlands

Fluke (Netherlands) B.V.
Zonnebaan 39
3606 CH Maarssen, The Netherlands
P.O. Box 225
3600 AE Maarssen, The Netherlands
Tel: (030) 436514

New Zealand

McLean Information Technology Ltd.
P.O. Box 18065
Glen Innes
Auckland 6, New Zealand
Tel: 587-037

Norway

Morgenstjerne & Co. A/S
Konghellegate 3
P.O. Box 6688, Rodelokka
Oslo 5, Norway
Tel: 09-47-2-356110

Pakistan

Pak International Operations
505 Muhammadi House
I.I. Chundrigar Road
P.O. Box 5323
Karachi-2 Pakistan
Tel: 221127/239052

Peru

Importaciones Y Representaciones
Electronicas S.A.
Avda. Franklin D. Roosevelt 105
Lima 1, Peru
Tel: 288650

Philippines

Spark Radio and Electronics Corp.
P.O. Box 610 Greenhills
Metro Manila, Philippines 3113
Tel: 78-78-16

Portugal

Equipamentos de Laboratorio, Ltda.
P.O. Box 1128
Lisbon 1000, Portugal
Tel: 09-351-19-574984

Republic of Singapore

Rank O'Connor's (PTE) Ltd.
98 Pasir Panjang Road
Singapore 0511
Republic of Singapore
Tel: 637944

Republic of South Africa

Fluke S.A. (Pty) Ltd.
P.O. Box 39797
Bramley 2018
Republic of South Africa
Tel: (011) 786-3170

Spain

Hispano Electronics S.A.
Apartado de Correos 48
Alcorcon (Madrid)
Spain
Tel: 09-34-1-6194108

Sweden

Teleinstrument AB
P.O. Box 4490
S-162 04 Vallingby 4
Sweden
Tel: 09-46-8-380370

Switzerland

Traco Electronic AG
Jenatschstrasse 1
8002 Zurich
Switzerland
Tel: 09-41-1-2010711



John Fluke Mfg. Co., Inc., P.O. Box C9090, Everett, WA 98206. Phone (206) 342-6300
Fluke (Holland) B.V., P.O. Box 5053, 5004 EB, Tilburg, The Netherlands. Phone (013) 673973

Litho in U.S.A. 12/81

5-13/5-14

Section 6

Options and Accessories

TABLE OF CONTENTS

OPTION/ MODEL NUMBER	DESCRIPTION	PAGE
ACCESSORIES		
Y8205	Soft Carrying Case	600-1
C-86	Ruggedized Carrying Case	600-1
M00-200-611	Offset Mounting Kit	600-2
M00-200-612	Center Mounting Kit	600-2
M00-200-613	Dual Mounting Kit	600-3
80T-H	Touch-Hold Probe	600-4
80T-150C	Temperature Probe °C	600-5
80T-150F	Temperature Probe °F	600-5
80i-600	Current Transformer	600-5
80J-10	Current Shunt	600-5
80K-6	High Voltage Probe	600-5
80K-40	High Voltage Probe	600-5
83RF	RF Probe	600-5
85RF	RF Probe	600-5
Y8100	DC/AC Current Probe	600-5
Y8101	AC Current Transformer	600-5
Y8134	Deluxe Test Lead Kit (safety designed)	600-5
Y8140	Slim-Flex Test Leads	600-5
OPTIONS		
-01	Rechargeable (Ni-Cad) Battery Option	601-1

OPTIONS AND ACCESSORIES

6-1. INTRODUCTION

6-2. This section of the manual contains information concerning the options and accessories available for use with your 8050A Digital Multimeter. This information is divided into subsections. All of the accessories are in one subsection, and the options are presented in separate subsections. To facilitate locating a section, the paragraph and page numbers correspond with the option number. For example, the paragraph and page numbers for Option 8050A-01 start from 601-1. All the accessory paragraph and page numbers start from 600-1. A list of replaceable parts and illustrations showing the part location and its reference designator are provided with each option section.

Accessories

600-1. INTRODUCTION

600-2. This subsection describes the basic use of the accessories available for your 8050A. For more detailed information, refer to the instruction sheet included with each accessory. When ordering an accessory, include its model name and number.

600-3. SOFT CARRYING CASE Y8205

600-4. The Model Y8205 Soft Carrying Case (shown in Figure 600-1) is designed for the storage and transport of the 8050A. The case provides adequate protection against normal handling and storage conditions. In addition to a shoulder strap, the Y8205 includes a storage compartment for test leads, power cord, and other compact accessories.

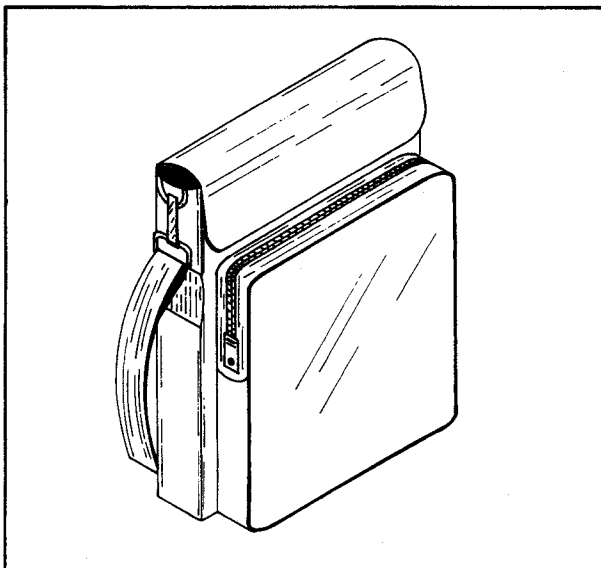

Figure 600-1. Model Y8205 Carrying Case

600-5. RUGGEDIZED CARRYING CASE C86

600-6. The Model C86 Ruggedized Carrying Case (shown in Figure 600-2) is a molded, polyethylene carrying case designed to provide maximum protection against rough handling and adverse environmental conditions. The C86 contains a separate storage compartment for test leads, power cord, and other compact accessories.

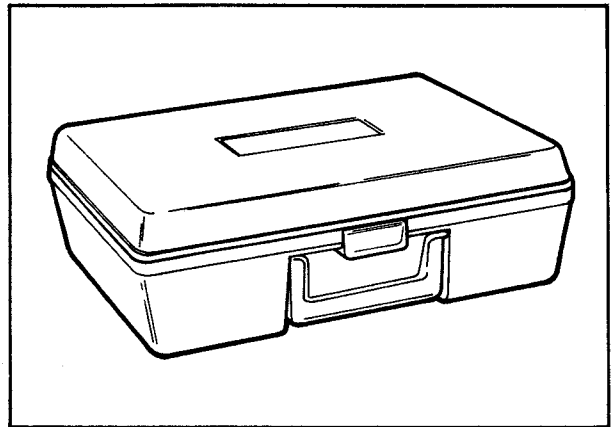

Figure 600-2. Model C86 Carrying Case

600-7. RACK MOUNTING KITS

600-8. Three rack mounting kits are available for mounting your instrument in a standard 19-inch equipment rack. The kits allow the 8050A to be mounted in the center, offset, or side-by-side (Dual) in a standard 19-inch equipment rack.

600-9. Installation

600-10. Installation instructions for the rack mounting kits are given in the following paragraphs.

ACCESSORIES

600-11. OFFSET AND CENTER MOUNTING KITS
M00-200-611 AND M00-200-612

600-12. Use the following procedure to install an 8050A using a center mounting or an offset mounting kit:

1. Remove the carrying handle by removing the handle disc decals and the handle mounting screws.
2. Remove the screw from the rear of the case and remove the case.
3. Install the side mounting brackets as shown in Figure 600-3, and secure them to the mounting panel using the nuts provided.

4. Insert the front of the case through the opening on the back side of the mounting panel.

5. Install the handle mounting screws through the side brackets into the mounting bosses. Don't overtighten these screws.

6. Slide the instrument through the mounting panel and into the case. Install and tighten the retaining screw at the rear of the case.

600-13. DUAL MOUNTING KIT M00-200-613

600-14. Use the following procedure to install an 8050A using a dual mounting kit:

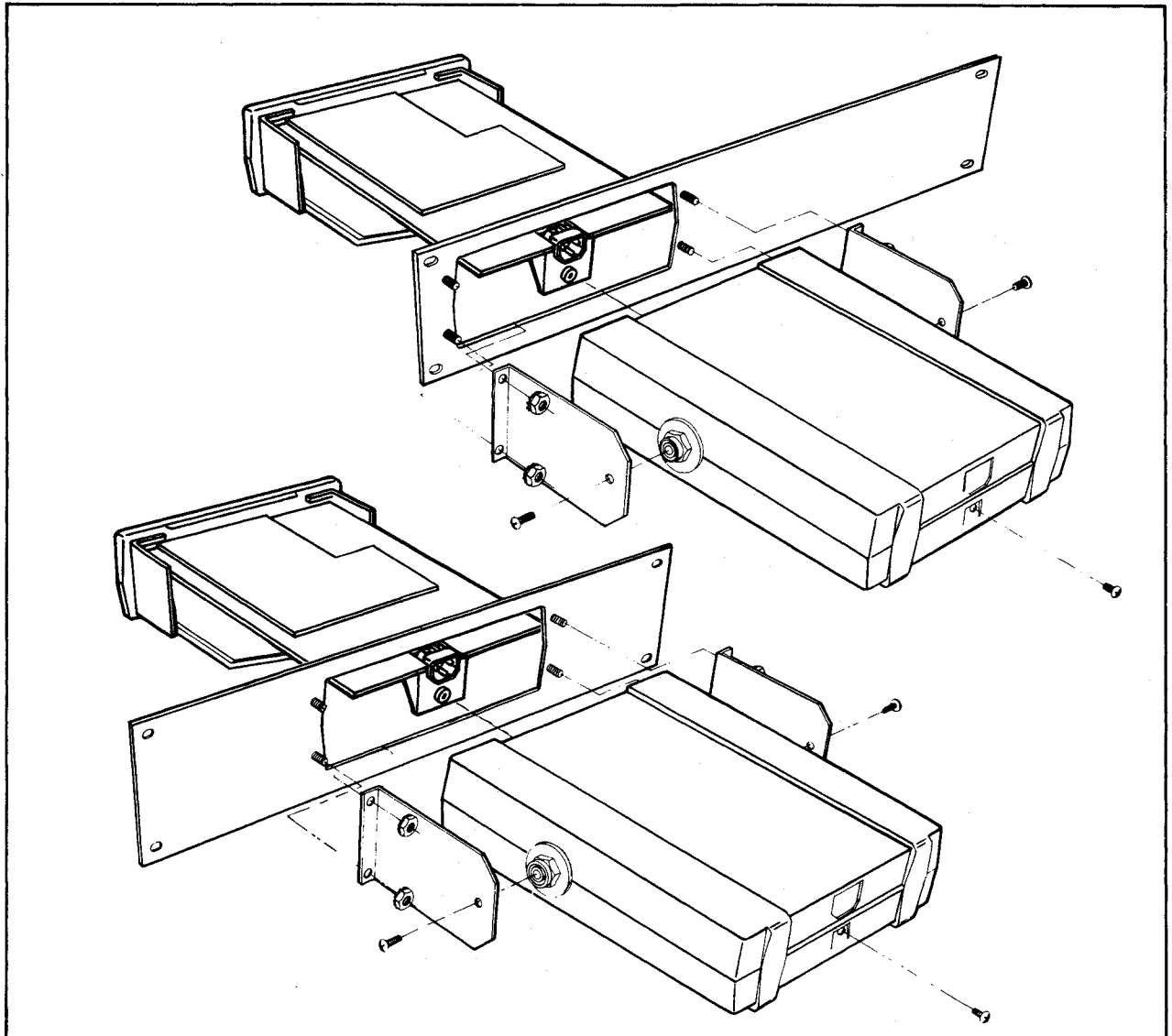

Figure 600-3. Rack Mounting Kits, Offset and Center Mounting

1. Remove the carrying handles from both instruments by removing the handle disc decals and the handle mounting screws.
2. Remove the retaining screw from the rear of the cases and separate the instruments from their cases.
3. Install the center mounting bracket as shown in Figure 600-4 and secure it to the mounting panel using the nuts provided.
4. Install the clamp screw in the center mounting bracket using the nuts and washers provided.
5. Insert the front of the instrument cases through the openings on the back side of the mounting panel. Make sure the cases' handle mounting bosses are inserted into the clamp hole of the center mounting bracket.
6. Tighten the clamp screws.
7. Install the side mounting brackets and secure them to the front panel using the nuts provided.
8. Install the handle mounting screws through the side brackets into the handle mounting bosses. Don't overtighten these screws.
9. Slide the instruments through the mounting panel and into their cases. Install and tighten the retaining screw at the rear of both cases.

600-15. PROBE ACCESSORIES

600-16. The probe accessories are shown in Figure 600-5 and are described in the following paragraphs. Table 600-1 contains all applicable specifications for the probes.

600-17. Touch-Hold Probe 80T-H

600-18. The 80T-H is a direct signal-through test probe with a touch and hold feature. Touch and Hold allows voltage, resistance, and conductance readings to be held on the DMM display following the measurement. This convenience also allows greater safety because the operator can concentrate on the placement of the probe and read the display later. The Touch and Hold feature is activated by a push button located on the probe. Pressing this push button holds the present reading on the DMM display until the push button is released.

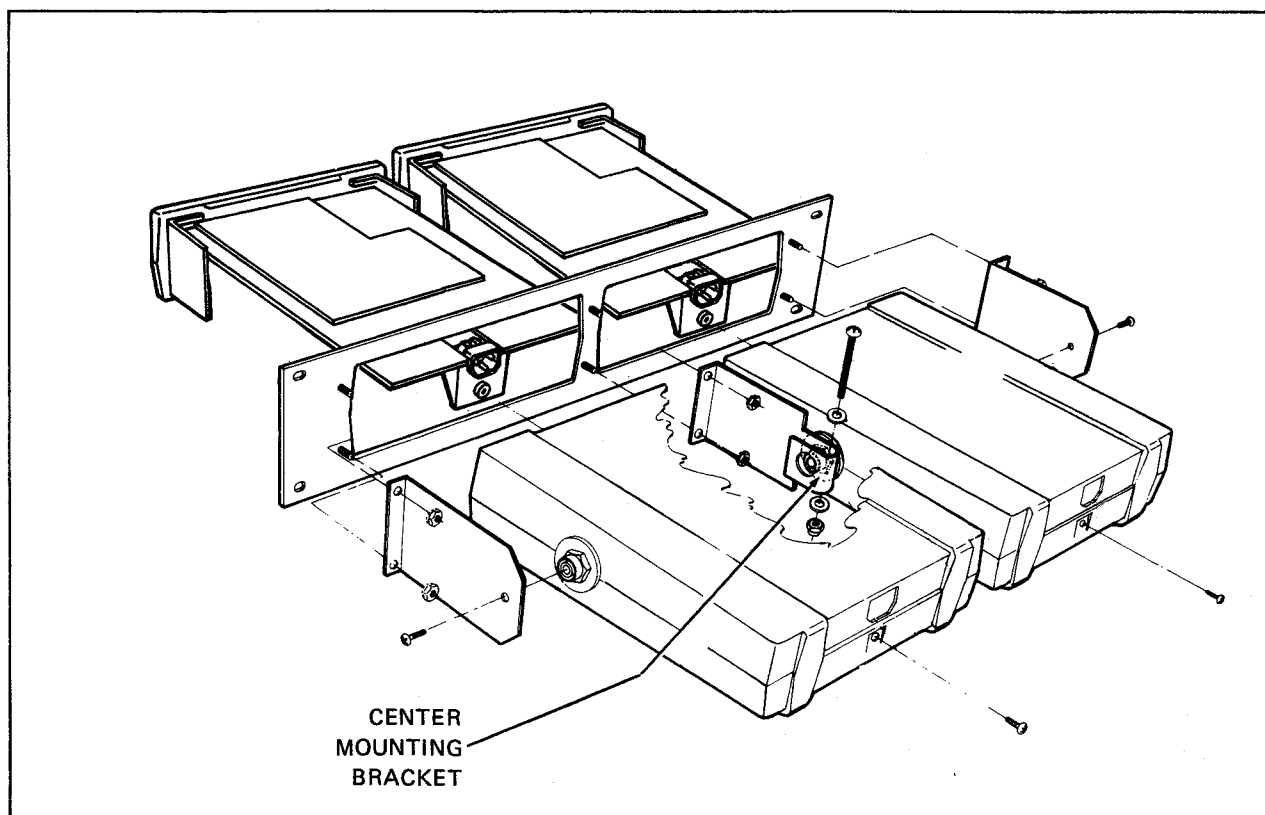

Figure 600-4. Rack Mounting Kit, Side-by-Side Mounting

ACCESSORIES

PROBE ACCESSORIES

600-19. Temperature Probe, Celsius 80T-150C

600-20. The 80T-150C Temperature Probe converts your instrument into a direct-reading (1 mV dc/degree) Celsius thermometer. It is suited for surface, ambient, and some liquid measurements. A rugged, fast-responding probe tip with a 350V dc standoff capability makes the 80T-150C a versatile and easy-to-use temperature probe.

600-21. Temperature Probe, Fahrenheit 80T-150F

600-22. The 80T-150F is the as the 80T-150C except the 80T-150F is set to read in degrees Fahrenheit.

600-23. Current Transformer 80I-600

600-24. The Model 80I-600 Current Transformer extends the maximum 2A ac current measuring limit of the 8050A to a maximum of 600A. The clamp-on transformer design allows measurements to be made without breaking the circuit under test. Because of a high-efficiency, quadrature-type of winding, wire size and location of the conductor within the transformer jaws do not affect the accuracy of the current measurement.

600-25. Current Shunt 80J-10

600-26. The Model 80J-10 Current Shunt extends the current measuring capability of your meter to 10A continuous (20A for periods not exceeding 1 minute) dc to 10 kHz at an accuracy of $\pm 0.25\%$.

600-27. High Voltage Probe 80K-6

600-28. The Model 80K-6 High Voltage Probe extends the voltage measuring capability of your meter up to 6 kV. Internally, the probe contains a 1000:1 divider. The divider is made with special metal film resistors with matched temperature coefficients, providing the probe with excellent accuracy and stability characteristics. Also, the very high input impedance (75 M Ω) minimizes circuit loading, thus contributing to measurement accuracy. The plastic housing provides for operator safety while measuring potentially dangerous voltages.

600-29. High Voltage Probe 80K-40

600-30. The Model 80K-40 High Voltage Probe extends the voltage measuring capability of your meter up to 40 kV. Internally, the probe contains a 1000:1 divider. The divider is made with special metal film resistors with matched temperature coefficients, providing the probe with excellent accuracy and stability characteristics. Also, the very high input impedance (1000 M Ω) minimizes circuit loading, thus contributing to measurement accuracy. The plastic housing provides for operator safety while measuring potentially dangerous voltages.

600-31. RF Probe 83RF

600-32. The 83RF converts the 8050A into a high frequency, 100 kHz to 100 MHz, ac voltmeter over a

voltage range of 0.25V to 30V rms. The DC output of the probe is calibrated to be equivalent to the rms value of a sine wave. The probe is used with the DC V function and ranges of the 8050A.

600-33. RF Probe 85RF

600-34. The 85RF converts the 8050A into a high frequency, 100 kHz to 500 MHz, ac voltmeter over a voltage range of 0.25V to 30V rms. The dc output of the probe is calibrated to be equivalent to the rms value of a sine wave. The probe is used with the DC V function and ranges of the 8050A.

600-35. DC/AC Current Probe Y8100

600-36. The Model Y8100 DC/AC Current Probe is a battery-powered (four AA cells) Hall-Effect probe for use with the 8050A to take dc, ac, or composite (ac or dc) current measurements. The clamp-on jaws on the Y8100 allow it to clamp around conductors up to 3/4-inch in diameter. The pistol shape allows safe, easy, one-hand operation when making current measurements. The Y8100 has detachable leads and is used in conjunction with the voltage inputs of the 8050A.

600-37. AC Current Transformer Y8101

600-38. The Model Y8101 Current Transformer (Figure 1) is a small clamp-on current transformer designed to extend the current measuring capability of an ac current meter up to 150A. A clamp-on coil designed into the probe allows measurements to be made without breaking the circuit under test. This coil serves as the secondary of a 1:1000 transformer. The current-carrying conductor being measured serves as the primary.

600-39. Deluxe Test Lead Set (safety designed) Y8134

600-40. The Model Y8134 Deluxe Test Lead Set includes two probes with sharp tips, two alligator clips, two spade lugs, and a spring-loaded hook tip. Banana plugs are recessed in an insulating shield. Probes contain finger guards for additional protection.

600-41. Slim-Flex Test Leads Y8140

600-42. The Model Y8140 Test Lead Set (Figure 1) consists of one red and one black 60-inch (1.52 meter) test lead, each with a standard banana plug on one end and an extendible tip probe on the other end. This flexible metallic tip conductor may be extended up to 2-1/2 inches, and is insulated to within 1/10 of an inch of its tip. This insulation reduces the chance of creating an inadvertent short circuit while using the probes in their extended configuration. Although the Y8140 test leads are intended for measuring voltages, they may also be used for measuring low currents.

ACCESSORIES
PROBE ACCESSORIES

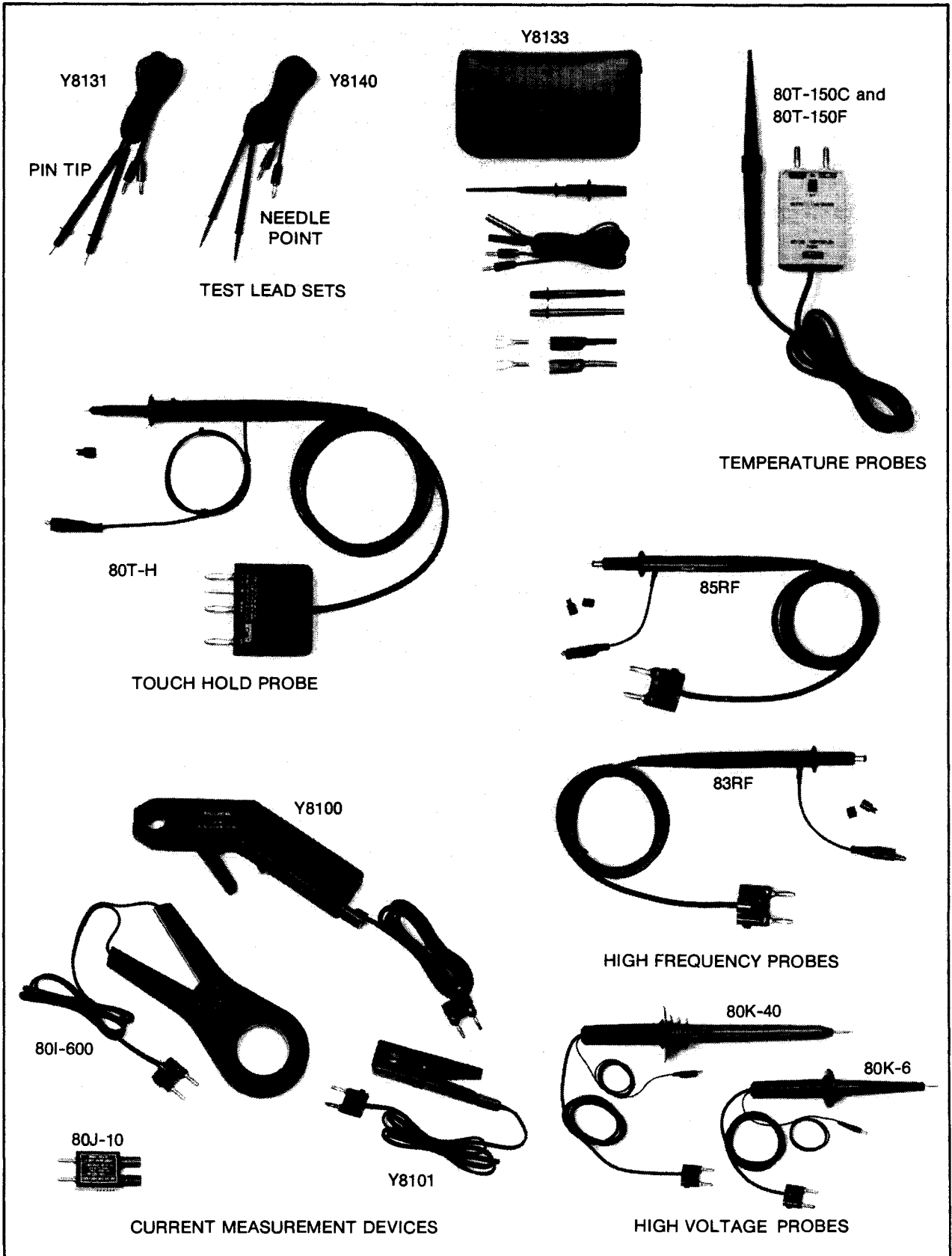

Figure 600-5. Probe Accessories

ACCESSORIES
PROBE ACCESSORIES

Table 600-1. Probe Accessories Specifications

80T-H TOUCH-HOLD PROBE

Voltage Ratings

TIP TO COMMON	1000V dc or peak ac maximum
COMMON TO GROUND	60V dc or 42V peak ac maximum
Input Capacitance	150 pF maximum
Lead Resistance	0.5Ω maximum

80T-150C AND 80T-150F TEMPERATURE PROBES

Range (°C/°F)	50°C to +150°C/-58°F to 302°F
Accuracy	±1°C (1.8°F) from 0°C to 100°C, decreasing linearly to ±3°C (5.4°F) at -50°C and +150°C
Sensitivity	1 mV dc/°C or °F
Resolution	0.1°C or 0.1°F recommended maximum
Voltage Standoff	350V dc or peak ac
Power	Internal disposable battery; 1,000 hours of continuous use

80I-600 CURRENT TRANSFORMER

Range	1 to 600A ac
Accuracy	±3%
Frequency Response	30 Hz to 1 kHz, 10 kHz typical
Division Ratio	1000:1
Working Voltage	750V rms maximum
Insulation Dielectric Withstand Voltage ..	5 kV
Maximum Conductor Size	2-inch diameter

80J-10 CURRENT SHUNT

Shunt	10 amps at 100 mV
Accuracy (18°C to 28°C)	
DC TO 10 KHZ	±0.25%
10 KHZ-100 KHZ	Rising to 1 dB at 100 kHz typical
Temperature Coefficient	0.005%/°C
Inductance	8.3 nH in series w/0.01Ω shunt
Overload	Up to one minute at 20A with a 1/4 duty cycle for recovery after currents between 10A and 20A
Connects to	3/4 inch center banana jacks
Connectors	5-way binding posts (red and black)

80K-6 HIGH VOLTAGE PROBE

Voltage Range	0 to 6 kV, dc or peak ac
Input Impedance	75 MΩ (nominal)
Division Ratio	1000:1
Accuracy	
DC TO 500 HZ	±1%
500 HZ TO 1 KHZ	±2%
ABOVE 1 KHZ	Output reading falls. Typically, 30% at 10 kHz.

80K-40 HIGH VOLTAGE PROBE

Voltage Range	1 kV to 40 kV dc or peak ac, 28 kV rms ac
Input Resistance	1000 MΩ
Division Ratio	1000:1
Accuracy Dc (overall)	20 kV to 30 kV ±2% (calibrated at 25 kV)
UPPER LIMIT	Changes linearly from 2% at 30 kV to 4% at 40 kV
LOWER LIMIT	Changes linearly from 2% at 20 kV to 4% at 1 kV
Accuracy Ac (Overall)	±5% at 60 Hz

Table 600-1. Probe Accessories Specifications (cont)

83RF HIGH FREQUENCY PROBE

AC-to-DC Ratio	1:1
Ratio Accuracy (at 1 MHz and loaded with 10 MΩ)	
ABOVE 1V	± 1 dB
BELOW 1V	± 1.5 dB
Frequency Response (Relative to 1 MHz)	100 kHz to 100 MHz ± 1 dB
Extended Frequency Response	Useful for relative readings from 20 kHz to 250 MHz
Response	Responds to the peak value of an input and is calibrated to read rms value of a sine wave
Voltage Range	0.25 to 30V rms
Maximum Input Voltage	30V rms, 200V dc
Input Capacitance	Approximately 3 pF
Temperature Range	
OPERATING	+10°C to +35°C
STORAGE	-40°C to +75°C
Humidity	<90% R.H.
Output Connector	Fits standard 0.75-inch dual banana connectors
Accessory	BNC to Probe Adapter, P/N 574756

85RF HIGH FREQUENCY PROBE

AC-to-DC Ratio	1:1
Ratio Accuracy (At 1 MHz and loaded with 10 MΩ)	
ABOVE 0.5V	± 0.5 dB
BELOW 0.5V	± 1.0 dB
Frequency Response (Relative to 1 MHz)	100 kHz to 100 MHz ± 5 dB
	*100 MHz to 200 MHz ± 1.0 dB
	*200 MHz to 500 MHz ± 3.0 dB
	*Referred to high and low inputs at probe tip.
Extended Frequency Response	Useful for relative readings from 20 kHz to 700 MHz
Response	Responds to the peak value of an input and is calibrated to read rms value of a sine wave
Voltage Range	0.25 to 30V rms
Maximum Input Voltage	30V rms, 200V dc
Input Capacitance	Approximately 3 pF
Temperature Range	
OPERATING	+10°C to +35°C
STORAGE	-40°C to +75°C
Humidity	<90% R.H.
Output Connector	Fits standard 0.75-inch dual banana connectors
Accessory	BNC to Probe Adapter, P/N 574756

Y8100 DC/AC CURRENT PROBE

Ranges	20A ac or dc
	200A ac or dc
Rated Output	2V at full range
Accuracy	
DC TO 200 HZ	$\pm 2\%$ of range
200 HZ TO 1 KHZ	<100A add $\pm 3\%$ reading
	>100A add $\pm 6\%$ reading
Calibration Cycle	1 year
Frequency Response	dc to 1.0 kHz
Recommended Load	≥ 3.0 k Ω
Temperature Range	+15°C to +35°C; for specified accuracy -10°C to +50°C; storage and operation at reduced accuracy.

ACCESSORIES
PROBE ACCESSORIES

Table 600-1. Probe Accessories Specifications (cont)

Heating Limitation	Prolonged operation above 200A ac or 1 kHz can cause damage to the Y8100.
Working Voltage Rating	Core to output; 600V dc or 480V ac maximum output to ground; 42V dc or 30V ac
Aperture Size	3/4-inch (19 mm) diameter
Size-Overall	9"x4-1/2"x1-7/16" (230 mm x 115 x 37 mm)
Weight	14 ounces (0.4 kg), with batteries
Power	Four AA cells
Battery Life	Alkaline 20 hours continuous

Y8101 AC CURRENT TRANSFORMER

Current Range	2A to 150A
ACCURACY, (48 Hz to 10 kHz)	±2%, 10A to 150A ±8%, 2A to 10A
Division Ratio	1000:1
Working Voltage	300V ac rms maximum
Insulation Dielectric Withstand Voltage ..	3 kV rms
Maximum conductor Size	7/16-inch (1.11 cm)

-01 Option Rechargeable Battery Option

601-1. INTRODUCTION

601-2. The Option 8050A-01 replaces the standard 8050A power supply with a power supply that will operate from either rechargeable batteries or line power. If the batteries are fully charged, your 8050A will operate for 10 hours (typical) before the batteries must be recharged.

601-3. SPECIFICATIONS

601-4. The specifications for the 8050A-01 are given in Table 601-1. All other specifications are equivalent to those given for the 8050A in Section 1 of this manual.

601-5. OPERATION

WARNING

**DO NOT OPERATE YOUR 8050A-01 WITH
THE BATTERIES REMOVED.**

601-6. Operation of an 8050A-01 differs in two respects from operation of a standard 8050A – battery charging and the BT annunciator on the display. When the BT

annunciator appears, on the display during operation, measurement accuracy may deteriorate beyond the limits specified in Section 1. If the BT annunciator appears and you still need to make additional measurements before recharging, set the POWER switch to the OFF position for a couple of minutes, then set the POWER switch back to the ON position. If the BT annunciator does not appear immediately, you have at least two minutes of in-specification operation. If the BT annunciator appears immediately after the POWER switch is set back to the ON position, none of the measurements should be accepted as being within the specified limits. Normally, when the BT annunciator appears, recharge the batteries as soon as possible.

601-7. To recharge the batteries, connect the 8050A-01 to line power and set the POWER switch to the OFF position. If the POWER switch is set to the ON position, the batteries receive a reduced charge that is sufficient to maintain their charge level but insufficient to charge the batteries to a higher level.

Table 601-1. 8050A-01 Specifications

<p>8050A-01 BATTERY OPTION:</p> <p>BATTERIES: TYPE: NiCAD OPERATING TIME: 10 hours, typical RECHARGE TIME: (with POWER switch in OFF position): 14 hours for full charge</p> <p>POWER CONSUMPTION: 6W max.</p> <p>LINE VOLTAGE: 90-264V, 47-440 Hz, field changeable</p> <p>STANDARDS: IEC 348: Protection Class 1 when operated from supply mains Protection Class 2 when operated from internal batteries</p>
--

OPTIONS

RECHARGEABLE BATTERY (-01 OPTION)

601-8. THEORY OF OPERATION

601-9. The theory of operation of the 8050A-01 is illustrated by the main pcb schematic in Section 7. The battery power supply is shown below the standard power supply on Sheet 1 of the schematic. The 8050A-01 can be used with line voltage from 90V to 264V, 47 to 440 Hz. (To select the proper line voltage configuration, refer to the 8050A-01 AC Line Voltage procedure, given later in this subsection.) Fuse F3 provides protection for the power supply. Line power input is rectified, filtered, and regulated. The output of the power supply acts as a current source for the battery. The battery determines the voltage level into the power converter. Do not operate the 8050A-01 with the battery removed. The power converter uses the flyback transformer technique to develop several output voltages so that +13V, -10V, +6V, and -5V (with respect to power supply common) are available.

609-10. When the battery voltage drops below approximately 4V, the BT annunciator appears in the display.

601-11. MAINTENANCE

WARNING

THESE SERVICING INSTRUCTIONS ARE FOR USE BY QUALIFIED PERSONNEL ONLY. TO AVOID ELECTRICAL SHOCK, DO NOT PERFORM ANY SERVICING OTHER THAN THAT CONTAINED IN THE OPERATING INSTRUCTIONS UNLESS YOU ARE QUALIFIED TO DO SO.

601-12. Battery Replacement

601-13. Use the following procedure for removing and replacing batteries:

1. Complete the Calibration Access procedure given in Section 4 of this manual.
2. Turn the instrument upside down.
3. Unplug the red and black battery wires, for both battery packs, from the pcb pins.
4. Apply pressure to the front and rear sides of the battery cases to disconnect the cases from the Main PCB Assembly.
5. Remove the blotting papers.

6. Replace the batteries (and blotting papers) with new Fluke battery assemblies.
7. Reconnect the battery cases to the Main PCB Assembly.
8. Connect the battery wires to their appropriate pins on the main pcb, with red to + and black to -.
9. Reinstall the instrument in its case.

601-14. Fuse Replacement

601-15. Use the following procedure to replace the main power fuse, F3:

1. Complete the Calibration Access procedure given in Section 4 of this manual.
2. F3 is located immediately in front of the power receptacle.
 - a. For 100V and 120V instruments, replace F3 with a 1/16A, 250V, type MDL fuse.
 - b. For 240V instruments, replace F3 with a 1/32A, 250V, type MDL fuse.

601-16. 8050A-01 Line Voltage Selection

601-17. Use the following procedure to change the operating ac line voltage on the 8050A-01:

1. Complete the Calibration Access procedure given in Section 4 of this manual.
2. Locate the ac line selection holes on the Main PCB Assembly. (The white wire from the power receptacle will be soldered in one of the holes.)
3. Relocate the white wire (from the power receptacle) to the pcb hole labeled with the intended voltage.
4. Reinstall the case and relabel the ac line voltage designation on the decal at the bottom of the instrument.

601-18. LIST OF REPLACEABLE PARTS

601-19. Tables 601-2 and 601-3 list replaceable parts for the 8050A-01. Figures 601-1 and 601-2 are the component location diagrams for the 8050A-01.

OPTIONS
RECHARGEABLE BATTERY (-01 OPTION)

Table 601-2. 8050A-01 Final Assembly

REF DES	DESCRIPTION	FLUKE STOCK NO.	MFG SPLY CODE	MFG PART NO.	TOT QTY	REC QTY	NO TE
	8050A FINAL ASSEMBLY WITH BATTERY OPTION FIGURE 601-1 (8050A-01)	8050A	WITH	BATTERY OPTION -01			
A1	MAIN PCB ASSEMBLY				1		
BT1, BT2	BATTERY, WIRED SET	487975	89536	487975	2		
F1	FUSE, FAST-ACT, 2A FOR EUROPEAN USAGE USE P/N	376582	71400	AGX-2	1	5	
F2	FUSE, FIBRE, 3A, 600V	460972	89536	460972	1	5	
F3	FUSE, SLD-BLD, 1/16A FOR EUROPEAN USAGE USE 1/32A, 5X20MM 240V. REPLACE FUSE CLIPS WITH FUSE. RELOCATE WHITE WIRE IN 240V HOLE.	475004	71400	BBS-3	1	5	
		163030	71400	MDL1-16	1	5	
H1	SCREW, PHP, 6-32 X 1/4	385401	73734	19042	5		
H2	SCREW, PHP, 6-32 X 1/2	320051	89536	320051	2		
H3	SCREW, RHP, 4-40 X 1/4	256156	89536	256156	5		
H4	SCREW, THD-FORMING, 5/20 X 5/16	494641	89536	494641	4		
H5	SCREW, SEMS, 6-32 X 1/4	178533	89536	178533	3		
H6	SCREW, PHP, 6/32 X 3/8	288266	89536	288266	2		
H7	WASHER, #6 FLAT	340505	89536	340505	2		
J1	CABLE, DISPLAY INTERCONNECT	507723	89536	507723	1		
LCD1	DISPLAY, LIQUID CRYSTAL	507673	89536	507673	1	1	
MP1	BEZEL, LCD	479642	89536	479642	1		
MP2	BRACKET, LCD	471730	89536	471730	1		
MP3	BUTTON, SWITCH (FUNCTION)	425900	89536	425900	4		
MP4	BUTTON, SWITCH (GREEN)	510271	89536	510271	1		
MP5	BUTTON, GRAY (OFFSET)	510164	89536	510164	1		
MP6	BUTTON, SWITCH (RANGE)	426759	89536	426759	6		
MP7	DECAL, CSA	525527	89536	525527	1		
MP8	CONNECTOR, ELASTOMERIC	453092	89536	453092	1		
MP9	FUSE HOLDER ASSEMBLY TO ORDER FUSE HOLDER CAP ONLY. FOR EUROPEAN USAGE USE P/N	516039	89536	516039	1		
		SEE	MP12				
MP10	INSERT, SILICONE	537076	89536	537076	2		
MP11	INSULATOR	525139	89536	525139	2		
		495044	89536	495044	1		
MP12	CAP, FUSEHOLDER (FOR SEPARATE ORDER) TO ORDER COMPLETE ASSEMBLY, SEE MP9 P/N.						1
MP13	DECAL, DISC (ON HANDLE)	478248	89536	478248	2		
MP14	PANEL, FRONT	510156	89536	510156	1		
MP15	RECEPTACLE, AC	471029	89536	471029	1		
MP16	RETAINER, FLEX	510198	89536	510198	2		
MP17	SHIELD, INSULATOR	516021	89536	516021	1		
MP18	SHIELD, MAIN	510172	89536	510172	1		
MP19	SHIELD, TOP	510180	89536	510180	1		
MP20	INSULATOR	525196	89536	525196	1		
MP21	DECAL, FRONT PANEL	508465	89536	508465	1		
MP22	CASE, EXTERIOR PLASTIC	478008	89536	478008	1		
MP23	HANDLE, MOLDED	330092	89536	330092	1		
MP24	DECAL, SPECIFICATION	507665	89536	507665	1		
MP25	TEST LEAD W/PROBE (Y8132)	516666	89536	516666	1		
MP26	LABEL, "Caution"	534487	89536	534487	1		
MP27	PAD, BATTERY ABSORBANT	483610	89536	483610	2	2	
MP28	RETAINER, BATTERY	471052	89536	471052	2		
MP29	GROMMET (USED IN SHIPMENT)	501593	89536	501593	1		
MP30	DECAL, FACTORY MUTUAL	524611	89536	524611	1		
MP31	JUMPER ASSY. (FOR U5)	537514	89536	537514	1	1	
MP32	JUMPER ASSY. (FOR U33)	537522	89536	537522	1	1	
MP33	BOX, UNIT SHIPMENT	697821	89536	697821	1		
MP34	BOX LINER	723155	89536	723155	1		
W1	LINE CORD	343723	89536	343723	1		
TM1	INSTRUCTION MANUAL (8050A)	530907	89536	530907	1		
	RECOMMENDED SPARE PARTS KIT (8050A)	533919	89536	533919	AR		

OPTIONS
RECHARGEABLE BATTERY (-01 OPTION)

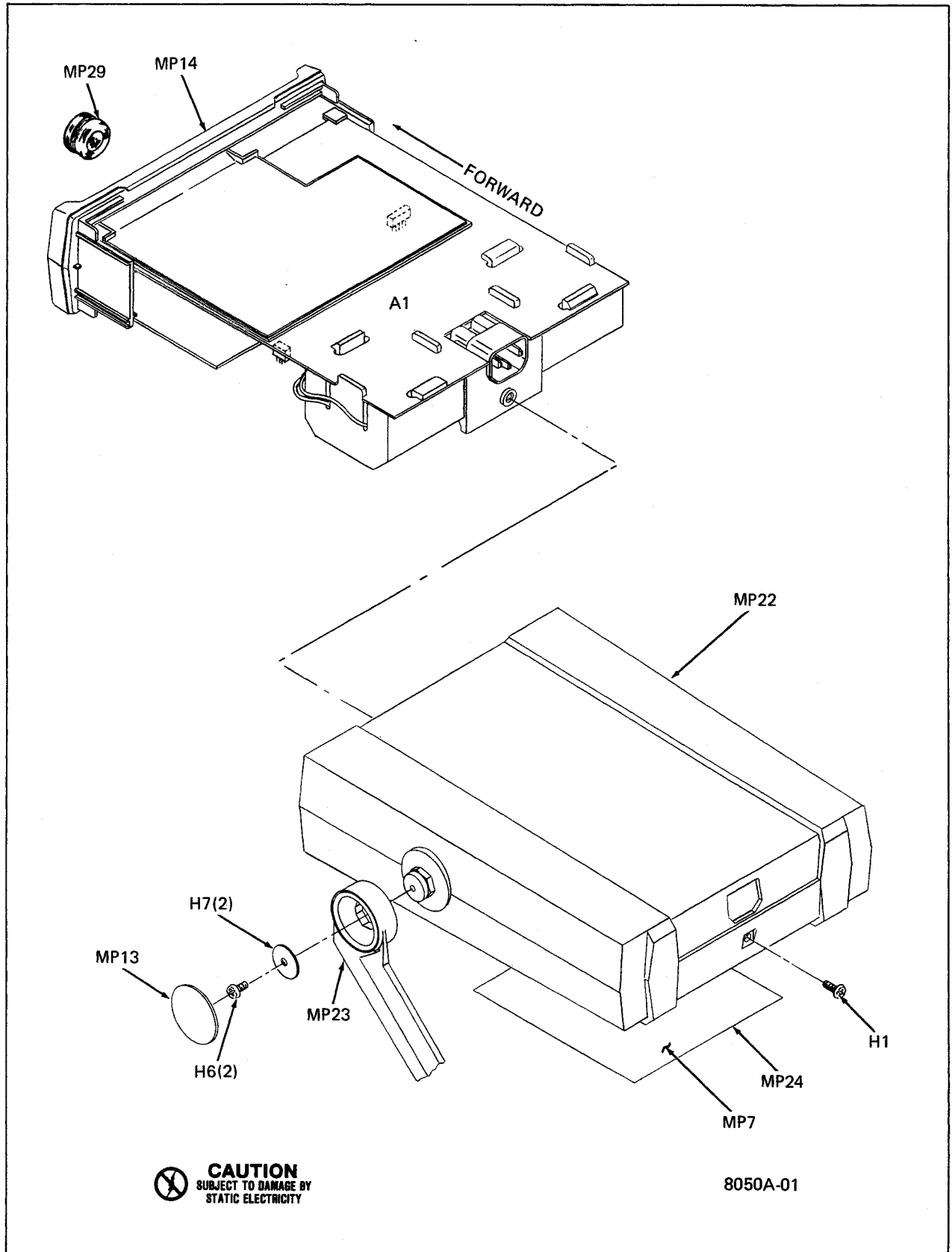

CAUTION
SUBJECT TO DAMAGE BY
STATIC ELECTRICITY

Figure 601-1. 8050A-01 Final Assembly

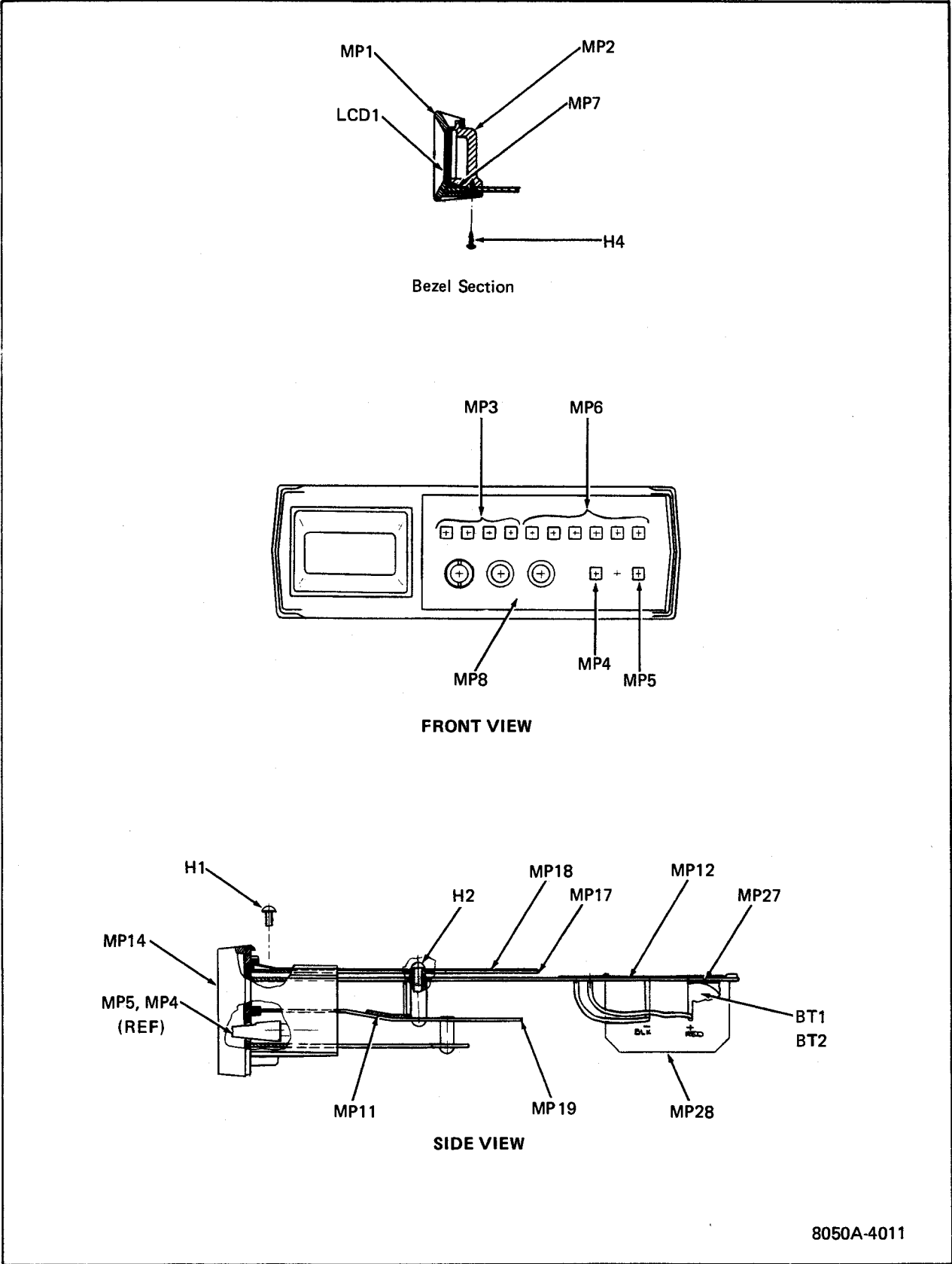

8050A-4011

Figure 601-1. 8050A-01 Final Assembly (cont)

OPTIONS
RECHARGEABLE BATTERY (-01 OPTION)

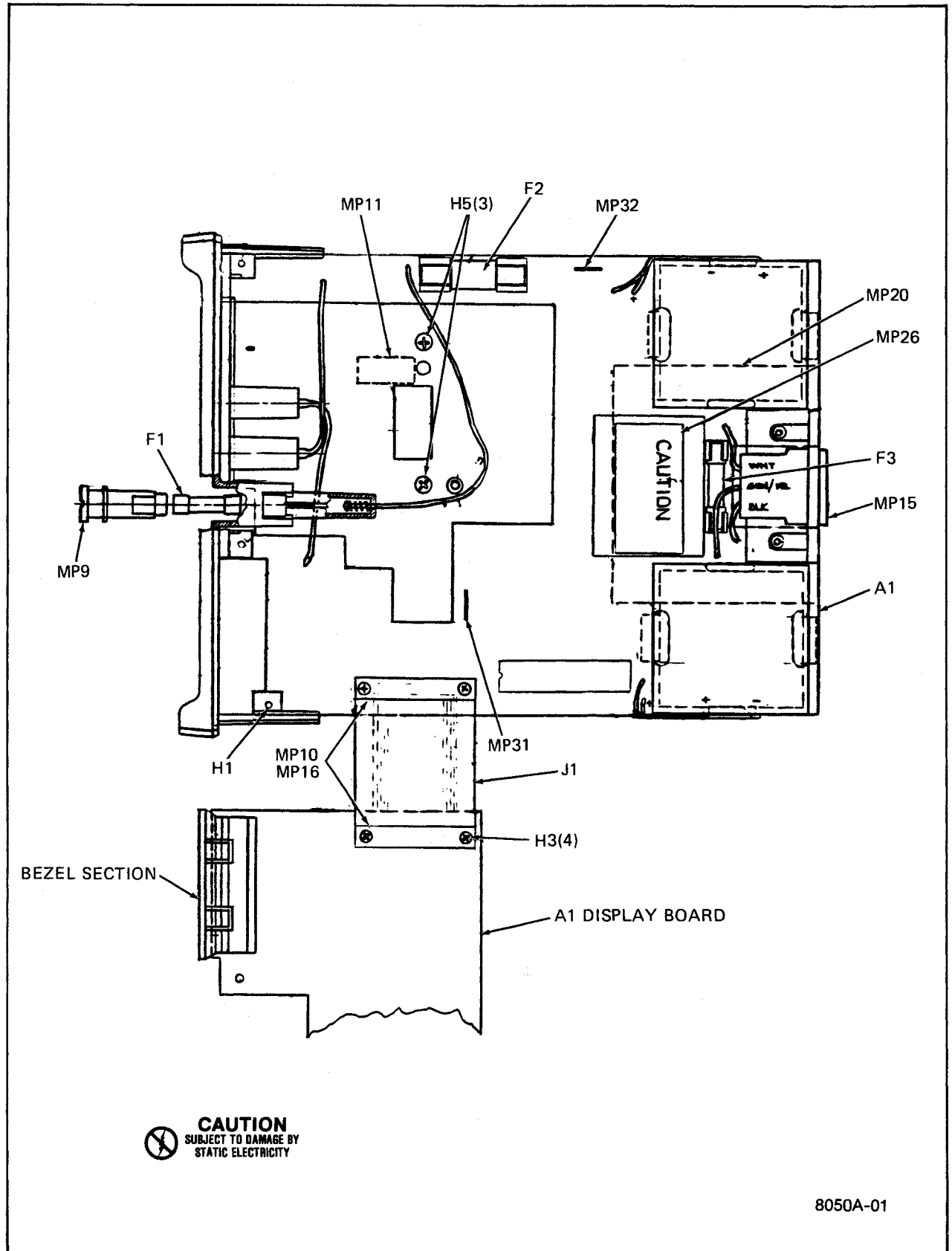

Figure 601-1. 8050A-01 Final Assembly (cont)

OPTIONS
RECHARGEABLE BATTERY (-01 OPTION)

Table 601-3. A1 Main PCB Assembly

REF DES	DESCRIPTION	FLUKE STOCK NO.	MFG SPLY CODE	MFG PART NO.	TOT QTY	REC QTY	NOTE
A1	MAIN PCB ASSEMBLY FIGURE 601-2 (8050A-4011AAI)		WITH	BATTERY OPTION -01			1 2
C1	CAP, VAR, 1-5-0.25 PF, 2000V	218206	72982	530-000	2		
C2	CAP, VAR, 1-5-0.25 PF, 2000V	218206	72982	530-000	REF		
C3	CAP, MICA, 120 PF +/-5%, 500V	148486	72136	DM15F121J	2		
C4	CAP, MICA, 120 PF +/-5%, 500V	148486	72136	DM15F121J	REF		
C5	CAP, MICA, 1800 PF +/-5%, 500V	148353	89536	148353	1		
C6	CAP, POLYPROP, 10 UF +/-10%, 100V	446781	89536	446781	1		
C7	CAP, POLYEST, 1.0 UF +/-10%, 100V	447847	37445	C280MAH/AIM	1		
C8	CAP, TA, 10 UF +/-20%, 15V	193623	56289	1960106X0015A1	4		
C9	CAP, POLYPROP, .22 UF +/-10%, 100V	446799	89536	446799	1		
C10	CAP, POLYESTER, .022 UF +/-10%, 1000V	448183	52763	PMT. 1822 322/10	1		
C11	CAP, MYLAR, .047 UF +/-10%, 250V	162008	73445	C280MAE/A47K	2		
C12	CAP, ELECT, 470 UF -10/+75%, 16V	501510	89536	501510	2		
C13	CAP, ELECT, 470 UF -10/+75%, 16V	501510	89536	501510	REF		
C14	CAP, TA, 10 UF +/-20%, 15V	193623	56289	1960106X0015A1	REF		
C15	CAP, TA, 22 UF +/-20%, 15V	423012	56289	1960226X0015KA1	1		
C20	CAP, ELECT, 2.2 UF +/-20%, 50V	614875	89536	614875	1		
C21	CAP, ELECT, 220 UF -10/+75%, 16V	435990	89536	435990	2		
C22	CAP, ELECT, 470 UF -10/+75%, 16V	501510	89536	501510	1		
C23	CAP, ELECT, 2200 UF -10/+75%, 16V	474981	89536	474981	1		
C25	CAP, CER, 1000 PF +/-20%, 100V	149153	56289	C0238101F103M	3		
C26	CAP, CER, 1000 PF +/-20%, 100V	149153	56289	C0238101F103M	REF		
C27	CAP, TA, 2.2 UF +/-20%, 20V	161927	56289	1960226X0020HA1	1		
C28	CAP, POLYPROP, .047 UF +/-10%, 100V	446773	89536	446773	1		
C29	CAP, MICA, 180 PF +/-5%, 500V	148460	72136	DM15F181J	1		
C30	CAP, MICA, 68 PF +/-5%, 500V	148510	72136	DM15F680J	1		
C31	CAP, MYLAR, .047 UF +/-10%, 250V	162008	73445	C280MAE/A47K	REF		
C32	CAP, CERAMIC, 1000 PF +/-10%, 500V	357806	56289	C0168102G-102K	3		
C33	CAP, TA, 10 UF +/-20%, 15V	193623	56289	1960106X0015A1	REF		
C34	CAP, ELECT, 47 UF -10/+75%, 16V	436006	89536	436006	1		
C35	CAP, CERAMIC, 1000 PF +/-10%, 500V	357806	56289	C0168102G-102K	REF		
C36	CAP, CERAMIC, 1000 PF +/-10%, 500V	357806	56289	C0168102G-102K	REF		
C37	CAP, CER, .025 UF +/-20%, 100V	168435	56289	C0238101H253M	1		
C38	CAP, ELECT, 47 UF +/-20%, 10V	613984	89536	613984	2		
C39	CAP, ELECT, 47 UF +/-20%, 10V	613984	89536	613984	REF		
C40	CAP, MICA, 330 PF +/-5%, 500V	148445	72136	DM15F331J	1		
C41	CAP, ELECT, 10 UF +/-20%, 16V	614859	89536	614859	2		
C42	CAP, TA, 10 UF +/-20%, 15V	193623	56289	1960106X0015A1	REF		
C43	CAP, CER, 1000 PF +/-20%, 100V	149153	56289	C0238101F103M	REF		
C44	CAP, ELECT, 10 UF +/-20%, 16V	614859	89536	614859	REF		
CL1	DIODE, FED, CURRENT REGULATOR	393454	07910	TCR5290	1	1	
CR1	DIODE, SI, RECTIFIER, 2 AMP, 50 VOLT	347559	14099	1M5400	1	1	
CR2	DIODE, SI, LO-CAP/LO-LEAK	348177	07263	FD7223	3	1	
CR3	DIODE, SI, LO-CAP/LO-LEAK	348177	07263	FD7223	REF		
CR4	DIODE, RECTIFIER	343491	01295	1N4002	1	1	
CR5, CR6	DIODE, SI, HI-SPEED SWITCHING	203323	07910	1N4448	2	1	
CR12	DIODE, SI, LO-CAP/LO-LEAK	348177	07263	FD7223	REF		
DS1	DIODE, LIGHT-EMITTING (LED) RED	429555	12040	NLS5053	1	1	
MP1	SPRING, COMPRESSION COIL	422824	83553	C0240-026-0500-8	1		
MP2	SUPPORT, HYBRID (TO U32)	515635	89536	515635	2		
MP3	CLIP, FUSE	485219	91833	3529	2		
MP4	HOUSING, LED (W/DS1)	522243	89536	522243	1		
MP5	HEATSINK, (W/U26)	473785	89536	473785	1		
MP6	SUPPORT, RESISTOR	545079	89536	545079	1		
MP7	CLIP, COMPONENT	516880	89536	516880	2		
MP8	SPACER, SWAGED	525154	89536	525154	4		
MP9	SPACER, STANDOFF	295089	89536	285089	2		
MP31	JUMPER ASSY (FOR U5)	417899	52072	CA-055-TSD	1		
MP32	JUMPER ASSY (FOR U33)	417311	30035	SS-109-1-04	1		
Q1	XSTR, SI, NPN	218396	89536	218396	3	1	
Q2	XSTR, SI, NPN	218396	89536	218396	REF		
Q3	XSTR, SI, NPN (METAL)	329698	89536	329698	1	1	
Q4	XSTR, SI, PNP	225599	07263	2N4250	2	1	

OPTIONS

RECHARGEABLE BATTERY (-01 OPTION)

Table 601-3. A1 Main PCB Assembly (cont)

REF DES	DESCRIPTION	FLUKE STOCK NO.	MFG SPLY CODE	MFG PART NO.	TOT QTY	REC QTY	NOTE
Q5	XSTR. SI. PNP	340026	04713	MP6563	1	1	
Q6	XSTR. SI. NPN. POWER	477331	04713	HD601A	1	1	
Q7	XSTR. FET	370072	89536	370072	2	1	
Q8	XSTR. FET	370072	89536	370072	REF		
Q10	XSTR. SI. PNP	175974	04713	2N3906	2	1	
Q11	XSTR. SI. PNP	175974	04713	2N3906	REF		
Q12	XSTR. SI. NPN	168716	07263	S19254	1	1	
Q14	XSTR. SI. PNP	380394	89536	380394	3	1	
Q15	XSTR. SI. PNP	380394	89536	380394	REF		
Q16	XSTR. SI. PNP	225399	07263	2N4250	REF		
Q17	XSTR. SI. PNP	380394	89536	380394	REF		
Q18	XSTR. SI. NPN	218396	89536	218396	REF		
Q19	XSTR. FET. DUAL N-CHANNEL	419283	89536	419283	1	1	
R1	RES. COMP. 100K +/-10%. 1W	109397	01121	G81041	1	1	
R2	RES. WJ. 1000 +/-10%. 2W	474080	89536	474080	1	1	
R3	RES. MTL. FILM. 1000 +/-5%. 1/10W	514265	89536	514265	1		
R5	RES. CER. 100K +/-10%. 1/2W	529099	89536	529099	1		
R6	RES. VAR. 100 +/-10%. 1/2W	529115	89536	529115	1	1	
R7	RES. VAR. CER. 1K +/-10%. 1/2W	513259	89536	513259	1	1	
R8	RES. COMP. 220K +/-10%. 2W	110197	01121	H81011	1		
R11	RES. VAR. CER. 500 +/-10%. 1/2W	447730	89536	447730	1	1	
R12	RES. CERNET. 200 +/-10%. 1/2W	474973	89536	474973	1		
R13	RES. MTL. FILM. 80.6K +/-1%. 1/8W	281121	91637	CHF558062F	1		
R14	RES. DEP. CAR. 1M +/-5%. 1/4W	348987	80031	CR251-4-5P1M	4		
R15	RES. DEP. CAR. 20 +/-5%. 1/4W	442202	80031	CR251-4-5P20E	2		
R16	RES. MTL. FILM. 900 +/-0.1%. 1/8W	461988	91637	CHF55901	1		
R17	RES. MTL. FILM 90 +/-0.1%. 1/8W	461970	91637	CHF55902	1		
R18	RES. WJ. 9 +/-15%. 1W	461962	89536	461962	1		
R19	RES. COMP. 100K +/-5%. 2W	285056	89536	285056	1		
R20	RES. COMP. 2.2M +/-10%. 1/2W	108225	89536	285056	1		
R21	RES. COMP. 22M +/-5%. 1/4W	221986	01121	CB2265	1		
R23	RES. DEP. CAR. 100 +/-5%. 1/4W	348771	80031	CR251-4-5P100E	2		
R24	RES. COMP. 4.7M +/-5%. 1/4W	220046	01121	CB4755	4		
R25	RES. DEP. CAR. 12 +/-5%. 1/4W	442178	80031	CR251-4-5P12E	1		
R26	RES. DEP. CAR. 9.1 +/-5%. 1/4W	441303	80031	CR251-4-5P9E1	1		
R27	RES. COMP. 10 +/-10%. 1/2W	108092	01121	EB1001	1		
R28	RES. DEP. CAR. 1K +/-5%. 1/4W	343426	80031	CR251-4-5P1K	1		
R29	RES. VAR. 1M +/-10%. 1/2W	485052	89536	485052	1	1	
R30	RES. DEP. CAR. 470K +/-5%. 1/4W	342634	80031	CR251-4-5P470K	1		
R31	RES. COMP. 470 +/-10%. 1/2W	108415	01121	EB4711	1		
R32	RES. DEP. CAR. 1M +/-5%. 1/4W	348987	80031	CR251-4-5P1M	REF		
R33	RES. DEP. CAR. 1M +/-5%. 1/4W	348987	80031	CR251-4-5P1M	REF		
R35	RES. MTL. FILM. 59K +/-1%. 1/8W	261677	91637	CHF555902F	1		
R36	RES. DEP. CAR. 15K +/-5%. 1/4W	348854	80031	CR251-4-5P15K	2		
R37	RES. COMP. 4.7M +/-5%. 1/4W	220046	01121	CB4755	REF		
R38	RES. DEP. CAR. 15K +/-5%. 1/4W	348854	80031	CR251-4-5P15K	REF		
R39	RES. MTL. FILM. 232K +/-1%. 1/8W	276618	91637	CHF552323	1		
R40	RES. DEP. CAR. 680 +/-5%. 1/4W	368779	80031	CR251-4-5P680E	1		
R42	RES. DEP. CAR. 27K +/-5%. 1/4W	441501	80031	CR251-4-5P27K	1		
R43	RES. DEP. CAR. 750K +/-5%. 1/8W	442525	80031	CR251-4-5P750K	1		
R44	RES. DEP. CAR. 100 +/-5%. 1/4W	348771	80031	CR251-4-5P100E	REF		
R45	RES. COMP. 4.7M +/-5%. 1/4W	220046	01121	CB4755	REF		
R46	RES. FXD. 27K +/-5%. 1/4W	441501	80031	CR251-4-5P27K	1		
R47	RES. DEP. CAR. 8.2K +/-5%. 1/4W	441675	80031	CR251-4-5P8K2	1		
R48	RES. DEP. CAR. 15K +/-5%. 1/4W	348854	80031	CR251-4-5P15K	REF		
R49	RES. DEP. CAR. 27K +/-5%. 1/4W	441501	80031	CR251-4-5P27K	1		
R51	RES. DEP. CAR. 20 +/-5%. 1/4W	442202	80031	CR251-4-5P20E	REF		
R52	RES. COMP. 47M +/-10%. 1/2W	146415	89536	146415	1		
R53	RES. COMP. 4.7M +/-5%. 1/4W	220046	01121	CB4755	REF		
R54	RES. DEP. CAR. 1M +/-5%. 1/4W	348987	80031	CR251-4-5P1M	REF		
R55	RES. DEP. CAR. 470K +/-5%. 1/4W	342634	80031	CR251-4-5P470K	1		
R56	RES. CAR. DEP. 1 +/-5%. 1/4W	357665	80031	CR251-4-5P1E	1		
RT1	THERMISTOR	446849	50157	180810200	1		
RV1	VARISTOR	447672	09214	V430MA7	3		3
RV2	VARISTOR	447672	09214	V430MA7	REF		

OPTIONS
RECHARGEABLE BATTERY (-01 OPTION)

Table 601-3. A1 Main PCB Assembly (cont)

REF DES	DESCRIPTION	FLUKE STOCK NO.	MFG SPLY CODE	MFG PART NO.	TOT QTY	REC QTY	NOTE
RV3	VARIATOR	447672	09214	V4301A7	REF		
S1-S10	SWITCH ASSEMBLY	507707	89536	507707	1		
S11	SWITCH	473736	89536	473736	2		
S12	SWITCH	473736	89536	473736	REF		
T2	TRANSFORMER, (BATTERY MODEL)	574489	89536	514489	1		
T3	XFRM, DC-DC (BATTERY MODEL)	614123	89536	614123	1		
TP1-5	TERMINAL PINS	379438	89536	379438	12		
TP7-13							
U1	RESISTOR NETWORK	501080	89536	501080	1	1	3
U2	RESISTOR NETWORK	512905	89536	512905	1	1	4
U3	RESISTOR NETWORK	513556	89536	513556	1	1	
U4	RESISTOR NETWORK	513580	89536	513580	1	1	
U5	RESISTOR NETWORK	519736	89536	519736	1	1	
U6	IC, RES, 2-RESISTOR SHUNT	461491	89536	461491	1	1	
U7	IC, OP-AMP, DUAL, COMPENSATED, 8-PIN DIP	418566	18324	LM359N/CR3999	2	1	
U8	IC, OP-AMP, DUAL, COMPENSATED, 8-PIN DIP	418566	18324	LM359N/CR3999	REF		
U9	IC, LOW POWER, DUAL VOLTAGE COMPARATOR	478354	01295	LM393N	2	1	
U10⊙	IC, C-MOS, LIQUID-CRYSTAL 4-SEGMENT	453225	02735	CD4054BE	3	1	
U11⊙	IC, C-MOS, LIQUID-CRYSTAL 4-SEGMENT	453225	02735	CD4054BE	REF		
U12⊙	IC, C-MOS, LIQUID-CRYSTAL DSPLY DRIVERS	507376	02735	CD40568E	4	1	
U13⊙	IC, C-MOS, LIQUID-CRYSTAL DSPLY DRIVERS	507376	02735	CD40568E	REF		
U14⊙	IC, C-MOS, LIQUID-CRYSTAL DSPLY DRIVERS	507376	02735	CD40568E	REF		
U15⊙	IC, C-MOS, LIQUID-CRYSTAL DSPLY DRIVERS	507376	02735	CD40568E	REF		
U16⊙	IC, C-MOS, LIQUID-CRYSTAL 4-SEGMENT	453225	02735	CD4054BE	REF		
U21	IC, OPERATIONAL AMP. (8050A-4504)	609883	89536	609883	2	1	
U22⊙	IC, C-MOS, QUAD BILATERAL SWITCH, 14-PIN	363838	12040	MC5616AN	1	1	
U23	IC, OPERATIONAL AMP. (8050A-4504)	609883	89536	609883	REF		
U26	VOLTAGE REGULATOR	473793	89536	473793	1	1	
U27	RESISTOR NETWORK	513598	89536	513598	1	1	
U28	RECTIFIER BRIDGE	418582	83003	VM08	2	1	
U30	RECTIFIER BRIDGE	418582	83003	VM08	REF		
U31	IC, LOW POWER, DUAL VOLTAGE COMPARATOR	478354	01295	LM393N	REF		
U32	HYBRID RMS TO DC CONVERTER	510685	89536	510685	1		
U33	RESISTOR NETWORK	513564	89536	513564	1	1	
U34	RESISTOR NETWORK	519728	89536	519728	1	1	
VR1	DIODE, ZENER	387217	89536	387217	1	1	
VR2, VR3	DIODE, ZENER, 3MA, 5.6V +/-5%(SELECT)	535559	89536	535559	2	1	
W1	WIRE ASSEMBLY (RED)	537159	89536	537159	1		
W2	WIRE ASSEMBLY (BLK)	537167	89536	537167	1		
W3	WIRE ASSEMBLY (WHT)	489096	89536	489096	1		
W4	WIRE ASSEMBLY (BLK)	489104	89536	489104	1		
W5	WIRE ASSEMBLY (WHT)	489120	89536	489120	1		
W6	WIRE ASSEMBLY (GRN, YEL)	489112	89536	489112	1		
XU17	SOCKET, IC	429282	09922	DIL840P-108	1		
XU18-20	SOCKET, 14-PIN	276527	09922	DIL88P-108	3		
Y1	CRYSTAL, 4 MHZ	474072	89536	474072	1		

- 1 Please be aware of voltage changes.
- 2 Certain components may not be used therefore may not be installed.
- 3 U1 P/N 510941 may be used in place of P/N 501080.
- 4 U2 P/N 510834 may be used in place of P/N 512905.

OPTIONS
RECHARGEABLE BATTERY (-01 OPTION)

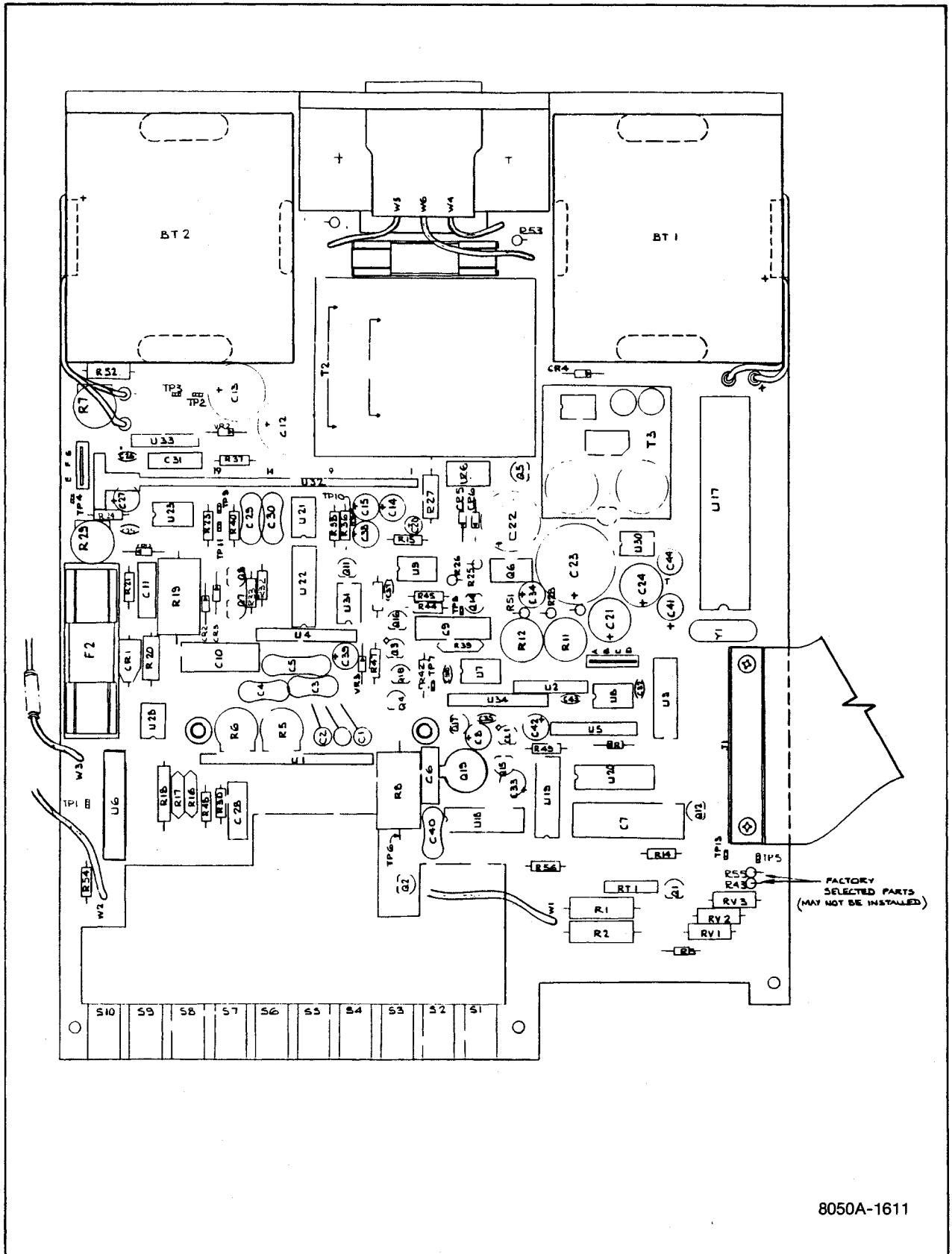
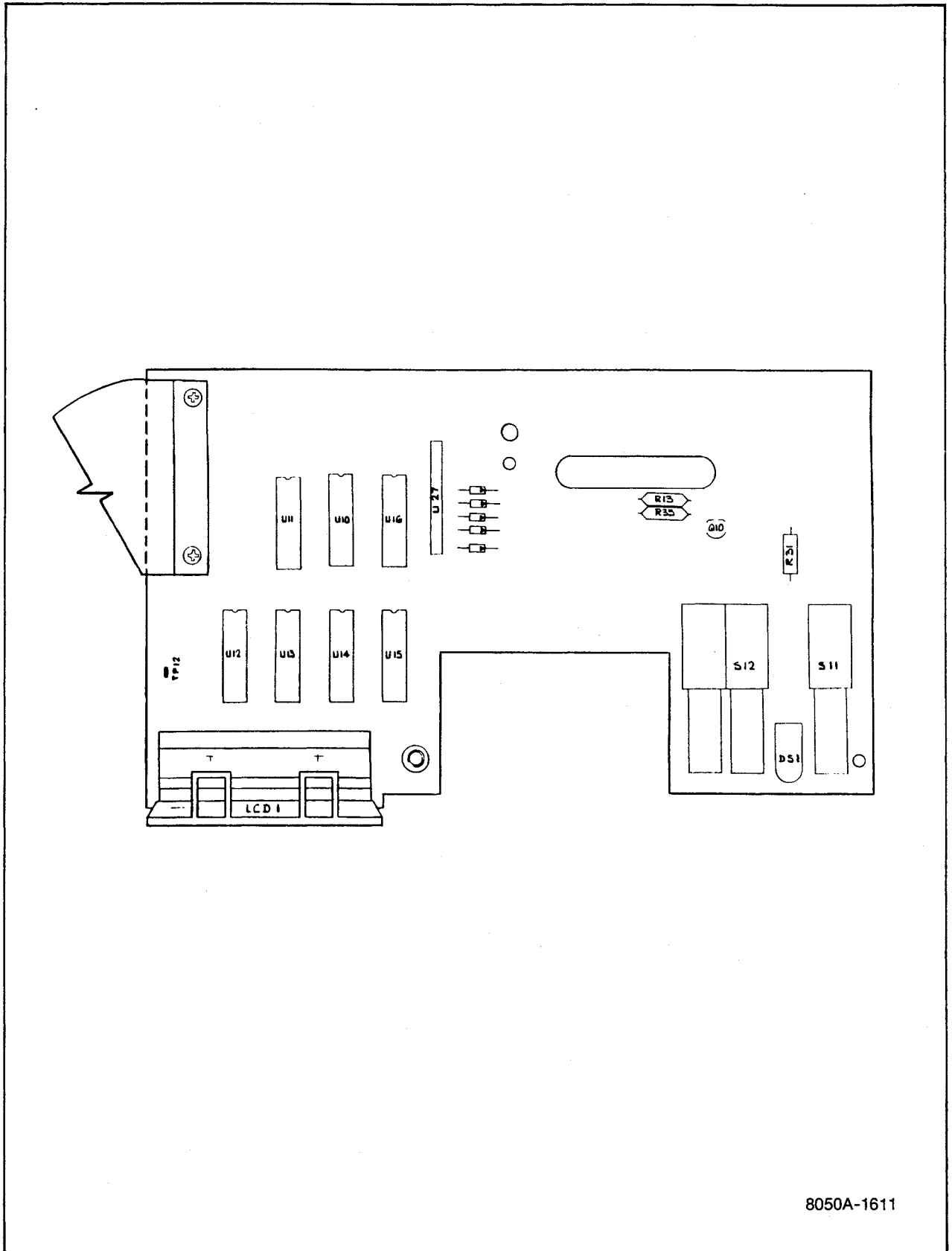

Figure 601-2. A1 Main PCB Assembly, 8050A-01



8050A-1611

Figure 601-2. A1 Main PCB Assembly, 8050A-01 (cont)

Section 7 Schematic Diagrams

TABLE OF CONTENTS

FIGURE	TITLE	PAGE
7-1.	Mnemonics	7-2
7-2.	A1 Main PCB Assembly, Line Supply	7-3
7-3.	A1 Main PCB Assembly, Schematic	7-4
7-4.	A1 Main PCB Assembly, Battery Option-01	7-6

**SCHEMATIC DIAGRAMS
MNEMONICS**

AC X 1	AC buffer gain of 1 command
AC X 100	AC Buffer gain of 100 command
AZ	Auto Zero
BP	Back plane drive signal, 50 Hz square wave
BT	Low Battery, indicates that the rechargeable batteries in the -01 Option need recharging
dB	Decibels
DE(+R)	De-integrate plus reference used with a negative input
DE(-R)	De-integrate minus reference used with a positive input
DP	Decimal Point
EXT INT	External Interrupt, stops the counter in the microcomputer
Fa] Function inputs to microcomputer
Fb	
Fc	
Fd	
HOLD	A 52 μ sec (maximum) period immediately following INT
HV	High Voltage, comes on when the instrument measures 40V or greater
INT	Integrate
LCD	Liquid Crystal Display
LO	Defines front panel selection of a function/range requiring an A/D gain of 10
\overline{OL}	A 5 msec period at the beginning of auto zero when an overrange is detected
P.O.R.	Power On Reset, a 500 msec pulse at turn on which initializes the A/D
REL	Relative, indicates that the readings displayed are relative to the input applied when the RELATIVE switch was set to ON
RNG a] Range inputs to microcomputer
RNG b	
RNG c	
S	Siemens, $1/\Omega$
ST0] Five sequential Strobe pulses
ST1	
ST2	
ST3	
ST4	
T&H	Touch & Hold
W] BCD data lines
X	
Y	
Z	
Z	Impedance

Figure 7-1. Mnemonics

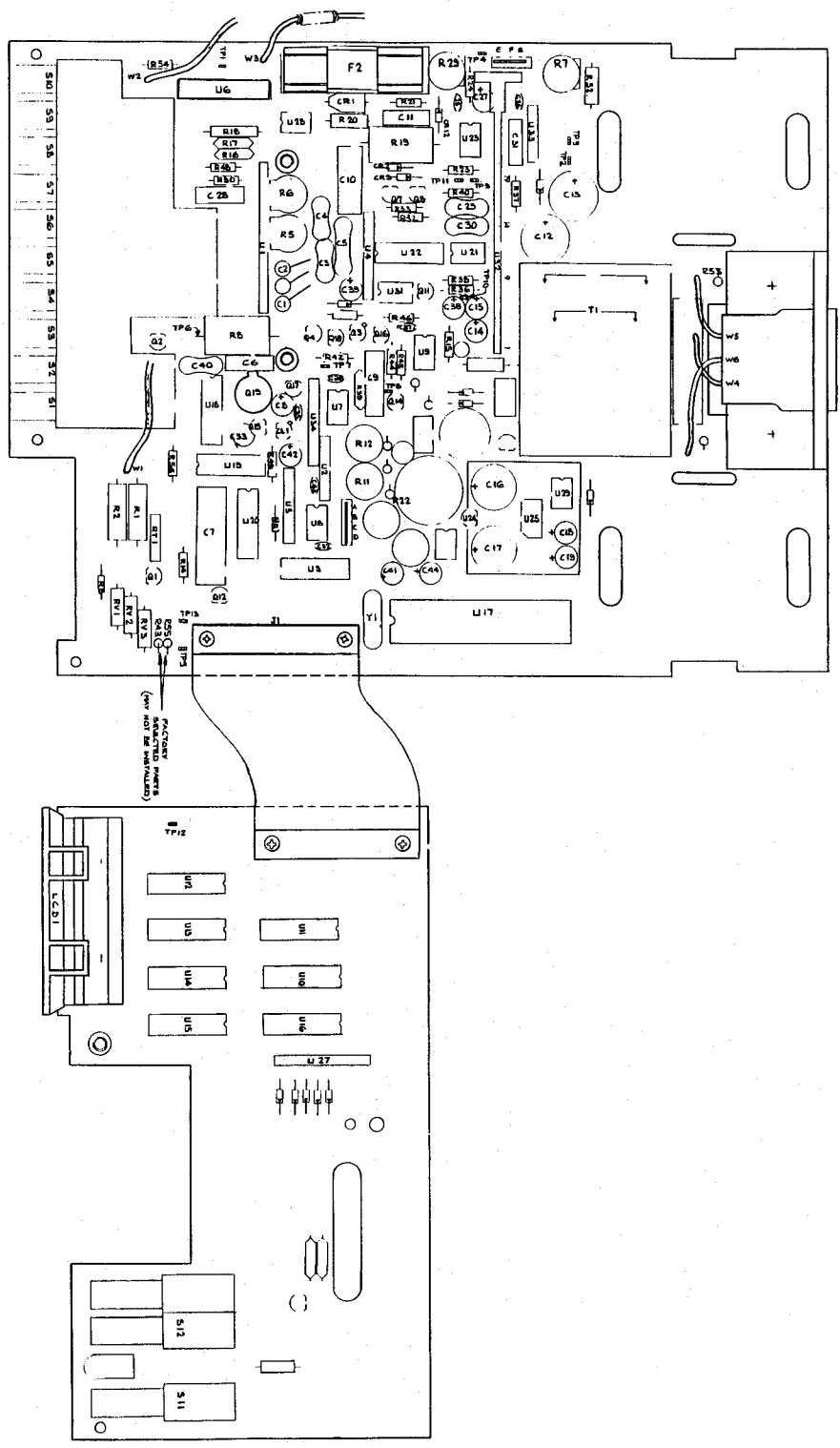

8050A-1601

Figure 7-2. A1 Main PCB Assembly, Line Supply

CAUTION
SUBJECT TO DAMAGE BY
STATIC ELECTRICITY

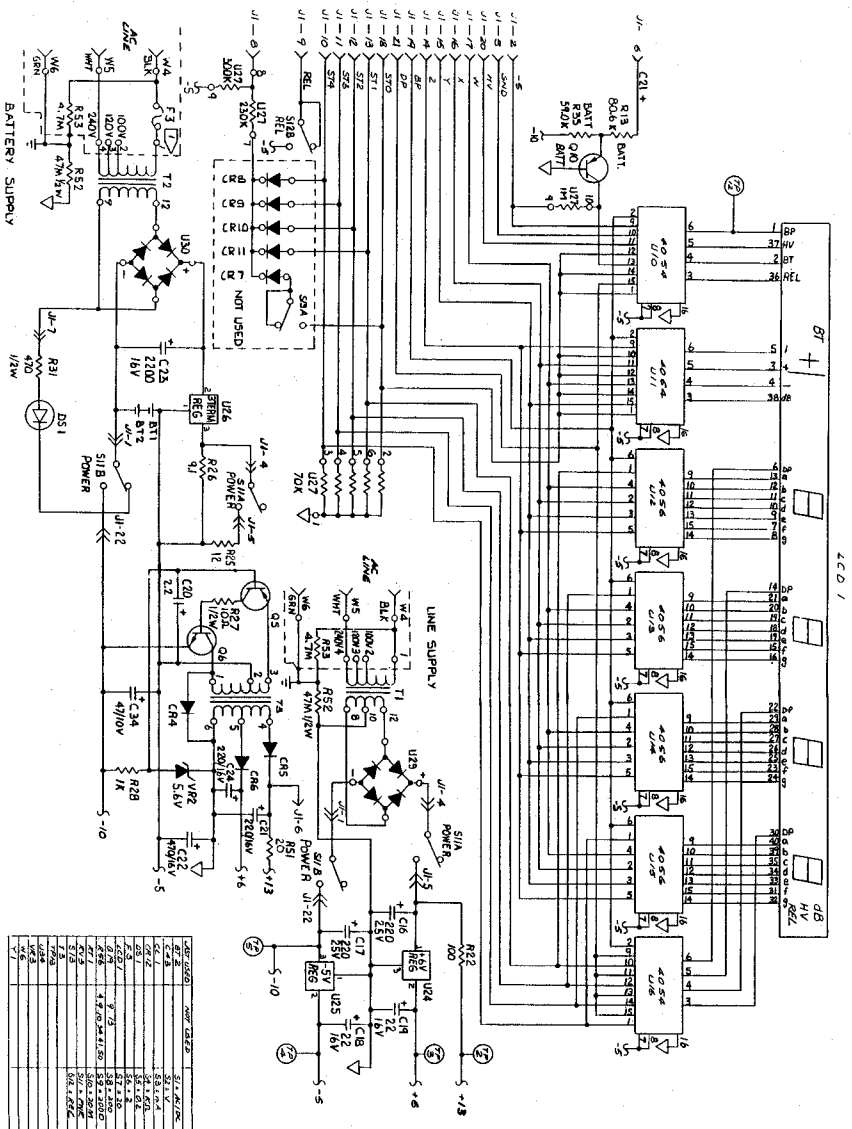

FOR LINE VERSION COMPONENT LOCATIONS, SEE FIGURE 5-2 OR 7-2.
FOR -01 BATTERY OPTION COMPONENT LOCATIONS, SEE FIGURE 601-2 OR 7-4.
SWITCHES ARE SHOWN IN THEIR RELAXED (OUT) POSITION.

Figure 7-3. A1 Main PCB Assembly, Schematic

8050A-1001
(1 of 2)

CAUTION
SUBJECT TO DAMAGE BY
STATIC ELECTRICITY

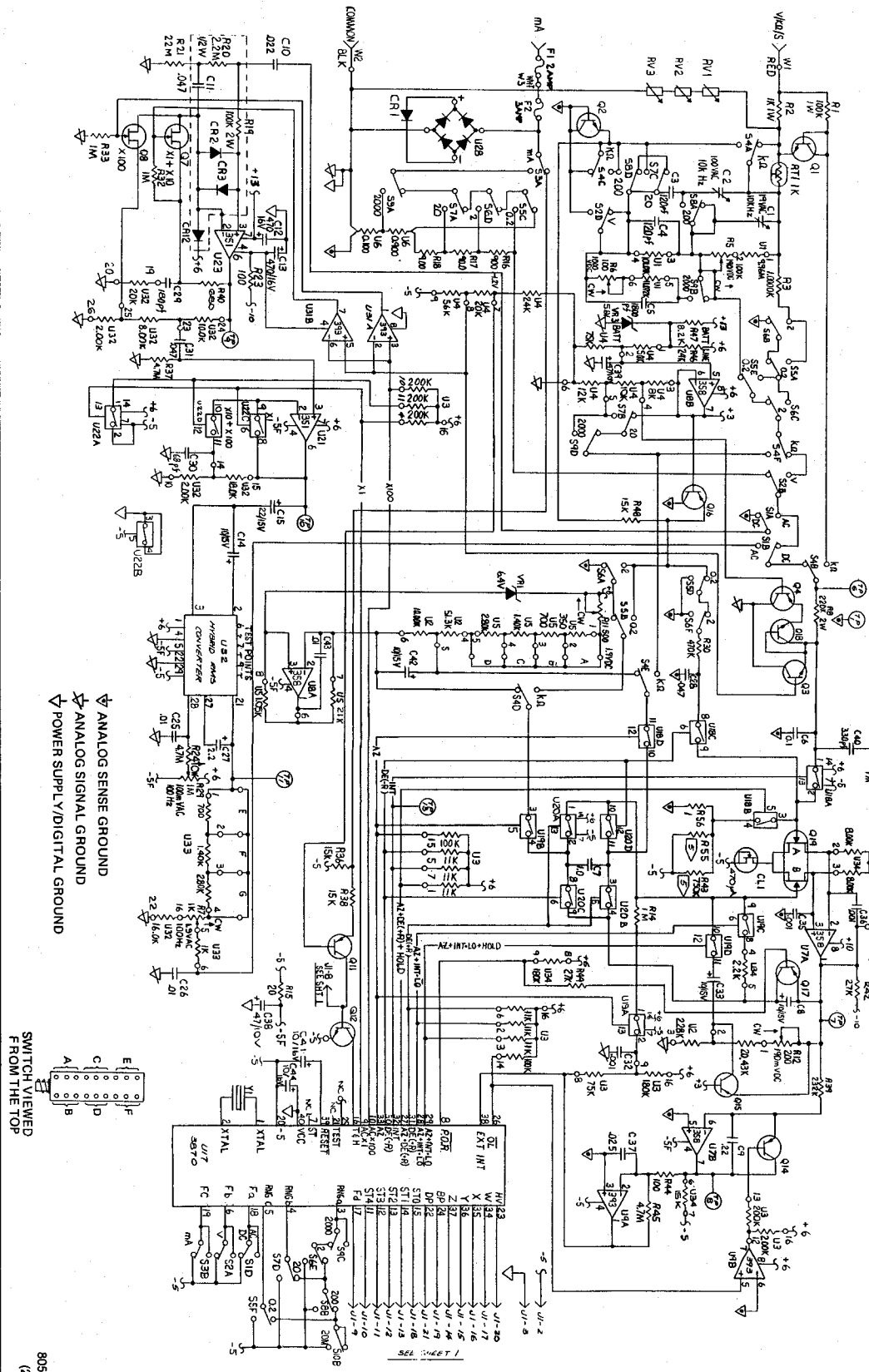
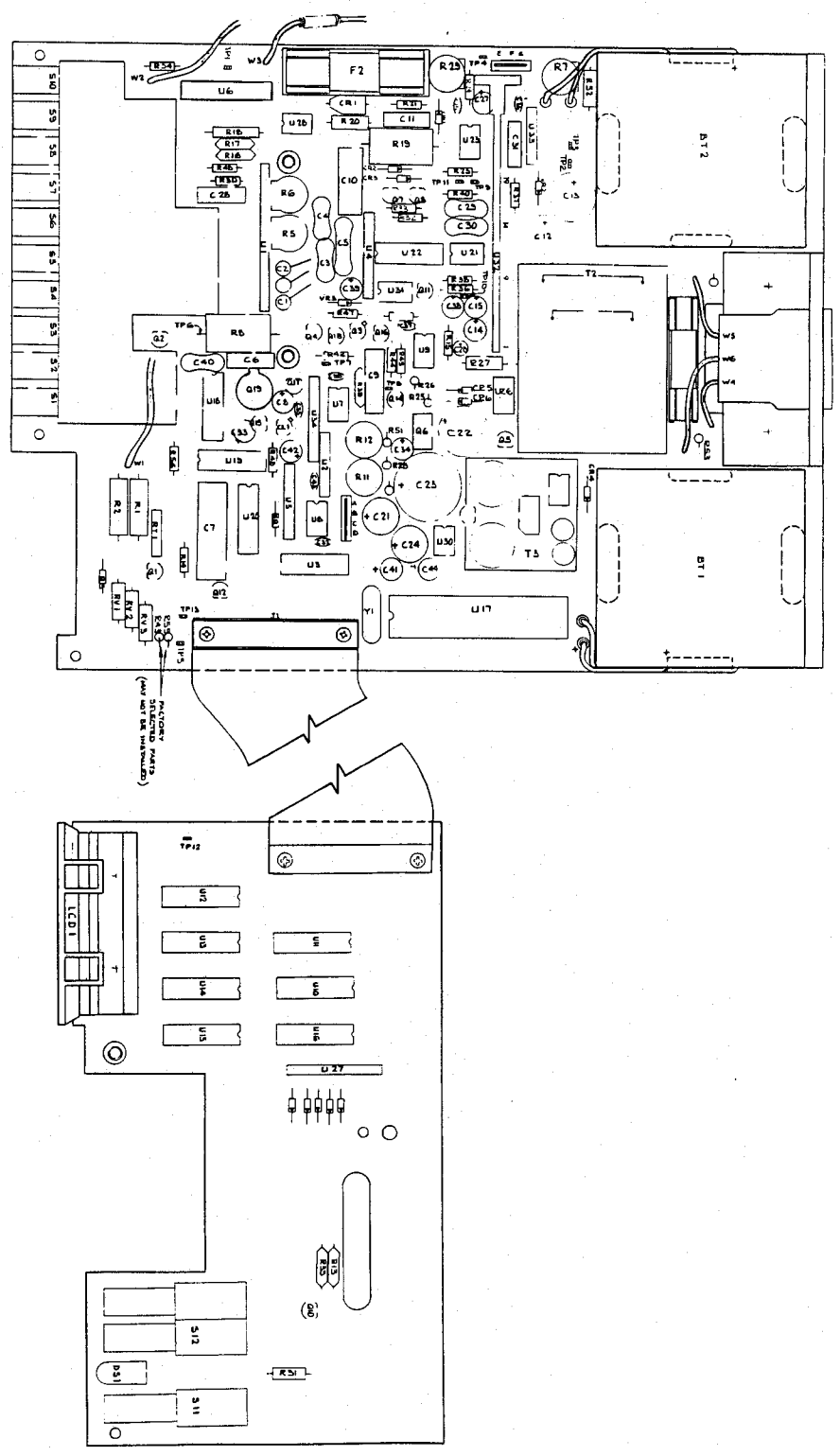

Figure 7-3. A1 Main PCB Assembly, Schematic (cont)

CAUTION
SUBJECT TO DAMAGE BY
STATIC ELECTRICITY



FOR SCHEMATIC DIAGRAM, SEE FIGURE 7-3.

Figure 7-4. A1 Main PCB Assembly, Battery Option -01