

45

Dual Display Multimeter

Service Manual

For IEC 1010 Meters Only

PN 609203

March 1999 Rev.1, 1/04

© 1999-2004 Fluke Corporation, All rights reserved. Printed in U.S.A.
All product names are trademarks of their respective companies.

LIMITED WARRANTY & LIMITATION OF LIABILITY

Each Fluke product is warranted to be free from defects in material and workmanship under normal use and service. The warranty period is one year and begins on the date of shipment. Parts, product repairs and services are warranted for 90 days. This warranty extends only to the original buyer or end-user customer of a Fluke authorized reseller, and does not apply to fuses, disposable batteries or to any product which, in Fluke's opinion, has been misused, altered, neglected or damaged by accident or abnormal conditions of operation or handling. Fluke warrants that software will operate substantially in accordance with its functional specifications for 90 days and that it has been properly recorded on non-defective media. Fluke does not warrant that software will be error free or operate without interruption.

Fluke authorized resellers shall extend this warranty on new and unused products to end-user customers only but have no authority to extend a greater or different warranty on behalf of Fluke. Warranty support is available if product is purchased through a Fluke authorized sales outlet or Buyer has paid the applicable international price. Fluke reserves the right to invoice Buyer for importation costs of repair/replacement parts when product purchased in one country is submitted for repair in another country.

Fluke's warranty obligation is limited, at Fluke's option, to refund of the purchase price, free of charge repair, or replacement of a defective product which is returned to a Fluke authorized service center within the warranty period.

To obtain warranty service, contact your nearest Fluke authorized service center or send the product, with a description of the difficulty, postage and insurance prepaid (FOB Destination), to the nearest Fluke authorized service center. Fluke assumes no risk for damage in transit. Following warranty repair, the product will be returned to Buyer, transportation prepaid (FOB Destination). If Fluke determines that the failure was caused by misuse, alteration, accident or abnormal condition of operation or handling, Fluke will provide an estimate of repair costs and obtain authorization before commencing the work. Following repair, the product will be returned to the Buyer transportation prepaid and the Buyer will be billed for the repair and return transportation charges (FOB Shipping Point).

THIS WARRANTY IS BUYER'S SOLE AND EXCLUSIVE REMEDY AND IS IN LIEU OF ALL OTHER WARRANTIES, EXPRESS OR IMPLIED, INCLUDING BUT NOT LIMITED TO ANY IMPLIED WARRANTY OF MERCHANTABILITY OR FITNESS FOR A PARTICULAR PURPOSE. FLUKE SHALL NOT BE LIABLE FOR ANY SPECIAL, INDIRECT, INCIDENTAL OR CONSEQUENTIAL DAMAGES OR LOSSES, INCLUDING LOSS OF DATA, WHETHER ARISING FROM BREACH OF WARRANTY OR BASED ON CONTRACT, TORT, RELIANCE OR ANY OTHER THEORY.

Since some countries or states do not allow limitation of the term of an implied warranty, or exclusion or limitation of incidental or consequential damages, the limitations and exclusions of this warranty may not apply to every buyer. If any provision of this Warranty is held invalid or unenforceable by a court of competent jurisdiction, such holding will not affect the validity or enforceability of any other provision.

To locate an authorized service center, visit us on the World Wide Web: www.fluke.com or call Fluke using the phone numbers listed below:

USA and Canada: 1-888-99-FLUKE (1-888-993-5853)

Europe: +31 402-675-200

Japan: +81-3-3434-0181

Singapore: +65-738-5655

Anywhere in the world: +1-425-446-5500

Fluke Corporation
P.O. Box 9090
Everett, WA 98206-9090
U.S.A.

Fluke Europe B.V.
P.O. Box 1186
5602 BD Eindhoven
The Netherlands

Table of Contents

Chapter	Title	Page
1	Introduction and Specifications	1-1
	1-1. Introduction.....	1-3
	1-2. Operating Instructions	1-3
	1-3. Options and Accessories.....	1-3
	1-4. Organization of the Service Manual	1-4
	1-5. Conventions	1-5
	1-6. Specifications.....	1-6
2	Theory of Operation	2-1
	2-1. Introduction.....	2-3
	2-2. Functional Block Description	2-3
	2-3. Power Supply.....	2-3
	2-4. Analog Measurement Processor	2-3
	2-5. Input Protection Circuit	2-3
	2-6. Input Signal Conditioning	2-3
	2-7. Analog-to-Digital (A/D) Converter	2-3
	2-8. Serial Communication (Guard Crossing)	2-3
	2-9. Digital Kernel	2-5
	2-10. Display Assembly.....	2-5
	2-11. IEEE-488 Interface Option (-05).....	2-5
	2-12. Battery Pack Option (-01)	2-5
	2-13. Detailed Circuit Description.....	2-5
	2-14. Power Supply Circuit Description.....	2-5
	2-15. Raw DC Supply.....	2-6
	2-16. 5-Volt Switching Supply.....	2-6
	2-17. Inverter	2-7
	2-18. Analog Measurement Processor	2-7
	2-19. Input Protection	2-10
	2-20. Input Signal Conditioning	2-10
	2-21. Relays	2-11
	2-22. DC Volts	2-12
	2-23. Ohms	2-12
	2-24. 100 M Ω and 300 M Ω Ranges.....	2-14
	2-25. AC Volts	2-14

2-26.	DCmA	2-15
2-27.	ACmA	2-15
2-28.	Amps	2-15
2-29.	Diode/Continuity Test.....	2-15
2-30.	Frequency	2-15
2-31.	Active Filter.....	2-16
2-32.	A/D Converter	2-17
2-33.	Serial Communication (Guard Crossing).....	2-18
2-34.	Digital Kernel	2-18
2-35.	RS-232 Interface	2-19
2-36.	Microprocessor	2-19
2-37.	EEROM.....	2-19
2-38.	RAM.....	2-20
2-39.	ROM.....	2-20
2-40.	IEEE-488 Option Connections.....	2-20
2-41.	Display Assembly.....	2-20
2-42.	Main Assembly Connector.....	2-20
2-43.	Front Panel Switches.....	2-20
2-44.	Display	2-21
2-45.	Beeper Drive Circuit	2-21
2-46.	Watchdog Timer and Reset Circuit.....	2-21
2-47.	Display Controller with FIP	2-22

3 General Maintenance 3-1

3-1.	Introduction.....	3-3
3-2.	Warranty Repairs and Shipping Information.....	3-3
3-3.	General Maintenance Information	3-3
3-4.	Required Equipment	3-3
3-5.	Power Requirements.....	3-3
3-6.	Static Safe Handling	3-3
3-7.	Cleaning	3-4
3-8.	Fuse Test and Replacement	3-4
3-9.	Line Fuse	3-4
3-10.	Current Input Fuses	3-4
3-11.	Testing Current Input Fuses	3-4
3-12.	Replacing the 500 mA and 440 mA Input Fuses (F1 and F5).....	3-5
3-13.	Replacing the 10 A Input Jack Fuse (F2).....	3-6
3-14.	Disassembly Procedures	3-7
3-15.	Remove the Meter Case.....	3-7
3-16.	Remove Handle and Mounting Brackets.....	3-7
3-17.	Remove the Front Panel Assembly	3-8
3-18.	Remove the Display PCA.....	3-8
3-19.	Remove the IEEE-488 Option	3-9
3-20.	Remove the Main PCA.....	3-9
3-21.	Remove the Analog Measurement Processor Shields	3-9
3-22.	Remove the Rms PCA	3-10
3-23.	Remove the Battery Option	3-10
3-24.	Disconnect Miscellaneous Chassis Components	3-10
3-25.	Assembly Procedures.....	3-10
3-26.	Install Miscellaneous Chassis Components	3-10
3-27.	Install the Battery Option	3-11
3-28.	Install the Rms PCA	3-11
3-29.	Install the Analog Measurement Processor Shields	3-11
3-30.	Install the Main PCA.....	3-11

3-31.	Install the IEEE-488 Option	3-12
3-32.	Assemble the Front Panel Assembly	3-12
3-33.	Install the Front Panel Assembly	3-15
3-34.	Install the Handle and Mounting Brackets	3-15
3-35.	Install the Meter Case	3-15
4	Performance Testing and Calibration	4-1
4-1.	Introduction	4-3
4-2.	Required Equipment	4-3
4-3.	Performance Tests	4-4
4-4.	Front Panel Calibration	4-7
4-5.	Introduction	4-7
4-6.	Entering Calibration Mode	4-8
4-7.	Exiting Calibration Mode	4-9
4-8.	DC Volts Calibration (Front Panel)	4-9
4-9.	AC Volts Calibration (Front Panel)	4-9
4-10.	DC and AC Milliamp Calibration (Front Panel)	4-9
4-11.	DC and AC Amps Calibration (Front Panel)	4-11
4-12.	Ohms Calibration (Front Panel)	4-11
4-13.	Alternate Ohms Calibration (Front Panel)	4-13
4-14.	Continuity/Hysteresis Threshold Calibration (Front Panel)	4-13
4-15.	Frequency Calibration (Front Panel)	4-13
4-16.	C2 Adjustment Procedure	4-13
4-17.	Editing the Prompt for Different Calibration Points	4-14
4-18.	Calibration Using the Computer Interface	4-15
4-19.	Setup	4-15
4-20.	RS-232 Interface	4-15
4-21.	IEEE-488 Interface	4-16
4-22.	The Calibration Procedure	4-18
4-23.	DC Volts Calibration (Computer Interface)	4-19
4-24.	AC Volts Calibration (Computer Interface)	4-19
4-25.	DC and AC Milliamps Calibration (Computer Interface)	4-19
4-26.	DC and AC Amps Calibration (Computer Interface)	4-19
4-27.	Ohms Calibration (Computer Interface)	4-19
4-28.	Continuity/Hysteresis Threshold Calibration (Computer Interface)	4-20
4-29.	Frequency Calibration (Computer Interface)	4-20
4-30.	Concluding Calibration Using the Computer Interface	4-20
4-31.	Alternate Ohms Calibration (Computer Interface)	4-20
5	Diagnostic Testing and Troubleshooting	5-1
5-1.	Introduction	5-3
5-2.	Servicing Surface-Mount Assemblies	5-3
5-3.	Error Codes	5-4
5-4.	General Troubleshooting Procedures	5-10
5-5.	Power Supply Troubleshooting	5-10
5-6.	Raw DC Supply	5-10
5-7.	5-Volt Switching Supply	5-11
5-8.	Inverter	5-12
5-9.	Analog Troubleshooting	5-13
5-10.	Uart Test	5-13
5-11.	DC Volts Troubleshooting	5-14
5-12.	AC Volts Troubleshooting	5-14
5-13.	Ohms Troubleshooting	5-14
5-14.	Digital Troubleshooting	5-15

5-15.	Display Assembly Troubleshooting.....	5-17
5-16.	Calibration Failures	5-19
5-17.	Introduction	5-19
5-18.	Calibration-Related Components	5-20
5-19.	Calibration Interrelationships	5-21
5-20.	Retrieving Calibration Constants	5-21
5-21.	Replacing the EEROM A1U5	5-21
6	List of Replaceable Parts.....	6-1
6-1.	Introduction.....	6-3
6-2.	How to Obtain Parts.....	6-3
6-3.	How to Contact Fluke	6-4
6-4.	Manual Status Information	6-4
6-5.	Newer Instruments	6-4
6-6.	Parts	6-4
7	Option -01 Battery Pack.....	7-1
7-1.	Introduction.....	7-3
7-2.	Specifications.....	7-3
7-3.	Theory of Operation	7-3
7-4.	Functional Block Description.....	7-3
7-5.	Switching Power Supply	7-5
7-6.	Cycle/Float Charge Rate Switch.....	7-5
7-7.	Low Battery Indicator Detector	7-5
7-8.	Low Battery Disconnect.....	7-5
7-9.	Constant Voltage Trickle Charger	7-6
7-10.	Other Circuits.....	7-6
7-11.	General Maintenance	7-6
7-12.	Removal.....	7-6
7-13.	Installation	7-7
7-14.	Performance Testing.....	7-9
7-15.	General Operability	7-9
7-16.	Low Battery Indicator Detector and Low Battery Disconnect Test	7-10
7-17.	Cycle/Float Charge Rate Switch Test	7-10
7-18.	Calibration	7-12
7-19.	Troubleshooting.....	7-13
7-20.	Additional Tests.....	7-14
7-21.	Schematic Diagram.....	7-14
7-22.	List of Replaceable Parts	7-14
8	Option -05 IEEE-488 Interface.....	8-1
8-1.	Introduction.....	8-3
8-2.	Theory of Operation	8-3
8-3.	Functional Block Description.....	8-3
8-4.	Detailed Circuit Description.....	8-3
8-5.	Main Assembly Connectors	8-3
8-6.	Address Decoding Circuit.....	8-3
8-7.	Isolation Circuits	8-4
8-8.	IEEE-488 Controller	8-4
8-9.	IEEE-488 Transceivers/Connector.....	8-5
8-10.	General Maintenance	8-8
8-11.	Removing the IEEE-488 Interface Option	8-8
8-12.	Installing the IEEE-488 Interface Option.....	8-9

8-13.	Performance Testing	8-9
8-14.	Troubleshooting	8-10
8-15.	Power-up Problems	8-10
8-16.	Communication Problems	8-10
8-17.	Failure to Select IEEE-488 Interface Option	8-10
8-18.	Failure to Handshake on IEEE-488 Bus	8-11
8-19.	Failure to Enter Remote	8-11
8-20.	Failure to Receive Multiple Character Commands	8-12
8-21.	Failure to Transmit Query Responses	8-12
8-22.	Failure to Generate an End or Identify (EOI)	8-12
8-23.	Failure to Generate a Service Request (SRQ)	8-12
8-24.	Schematic Diagram	8-12
8-25.	List of Replaceable Parts	8-12

9 Schematic Diagrams 9-1

Index

List of Tables

Table	Title	Page
1-1.	Accessories.....	1-4
2-1.	Analog Measurement Processor Pin Name Description	2-9
2-2.	Relay Operation	2-11
2-3.	Reference Resistance	2-13
2-4.	AC Volts Input Signal Dividers	2-14
2-5.	Front Panel Switch Scanning	2-21
2-6.	Display Initialization Modes	2-23
3-1.	Fuses.....	3-6
4-1.	Recommended Test Equipment	4-3
4-2.	Performance Tests for Volts, Diode Test, Ohms, and Frequency Functions.....	4-5
4-3.	Performance Tests for mA Current Functions	4-7
4-4.	Performance Tests for Current Functions	4-7
4-5.	Front Panel Calibration	4-10
4-6.	Specifications Increase with Different Calibration Points.....	4-15
4-7.	Calibration Using the Computer Interface	4-17
4-8.	Calibration Mode Computer Interface Commands	4-21
4-9.	EEROM Calibration Constants	4-22
5-1.	Error Codes	5-5
5-2.	Power Supplies.....	5-11
5-3.	DC Volts Troubleshooting	5-14
5-4.	AC Volts Troubleshooting	5-15
5-5.	Display Initialization.....	5-18
5-6.	Calibration Steps and Related Components	5-22
5-7.	Components Unique to Calibration Steps.....	5-23
5-8.	Calibration Hierarchy.....	5-24
5-9.	Calibration Constants	5-24
6-1.	Manual Status Information.....	6-4
6-2.	Final Assembly.....	6-5
6-3.	A1 Main PCA.....	6-8
6-4.	A1A1 True Rms PCA	6-12
6-5.	A2 Display PCA.....	6-13
7-1.	Option -01 Battery Pack Final Assembly.....	7-15
7-2.	A4 Battery Pack PCA.....	7-16
8-1.	IEEE-488 Transceiver Control.....	8-6
8-2.	Option -05 IEEE - 488 Interface Final Assembly	8-13

8-3. A5 IEEE-488 Interface PCA 8-14

List of Figures

Figure	Title	Page
2-1.	Overall Functional Block Diagram	2-4
2-2.	Analog Simplified Schematic Diagram.....	2-8
2-3.	DC Volts 300 V Range Simplified Schematic	2-12
2-4.	Ohms Simplified Schematic	2-13
2-5.	AC Buffer Simplified Schematic	2-14
2-6.	DC mA and Amps Simplified Schematic.....	2-16
2-7.	Active Filter Simplified Schematic	2-17
2-8.	A/D Converter Simplified Schematic	2-18
2-9.	Command Byte Transfer Waveforms	2-23
2-10.	Grid Control Signal Timing	2-24
2-11.	Grid-Anode Timing Relationships	2-24
3-1.	Replacing the Line Fuse (F3).....	3-5
3-2.	Replacing the External 100 mA Input Fuse (F1)	3-6
3-3.	Removing the Case.....	3-7
3-4.	Removing the Handle and Handle Mounting Brackets.....	3-8
3-5.	Assembly Details	3-13
4-1.	Four Wire Configuration.....	4-12
4-2.	C2 Location	4-14
5-1.	Test Point Locator	5-6
5-2.	Volt Switching Supply	5-12
5-3.	Main Processor Timing	5-16
5-4.	Display Controller to Microprocessor Signals.....	5-17
5-5.	Primary Display.....	5-18
5-6.	Secondary Display	5-18
6-1.	Final Assembly.....	6-6
6-2.	A1 Main PCA.....	6-11
6-3.	A1A1 True Rms PCA	6-12
6-4.	A2 Display PCA.....	6-14
7-1.	Battery Pack Option Functional Block Diagram.....	7-4
7-2.	Removing the Case.....	7-7
7-3.	Installing the Battery Kit.....	7-8
7-4.	Battery Pack Option Connecting Cable	7-9
7-5.	Cycle/Float Charge Rate Switch Test	7-11
7-6.	Unplugging the Battery Pack Connectors	7-13
7-7.	Test Points and Adjustments.....	7-14

7-8.	Option-01 Battery Pack Final Assembly.....	7-15
7-9.	A4 Battery Pack PCA.....	7-18
8-1.	Disassembly	8-6
8-2.	IEEE-488 Interface Connector	8-7
8-3.	IEEE-488 Module Assembly.....	8-8
8-4.	IEEE-488 Interface Performance Test	8-10
8-5.	Option -05 IEEE-488 Interface Final Assembly	8-13
8-6.	A5 IEEE-488 Interface PCA	8-15
9-1.	A1 Main PCA.....	9-2
9-1.	A1 Main PCA.....	9-2
9-2.	A2 Display PCA.....	9-8
9-3.	A1A1 True Rms PCA	9-10
9-4.	A4 Battery PCA	9-12
9-5.	A5 IEEE-488 Interface PCA	9-14

Chapter 1

Introduction and Specifications

	Title	Page
1-1.	Introduction.....	1-3
1-2.	Operating Instructions	1-3
1-3.	Options and Accessories.....	1-3
1-4.	Organization of the Service Manual	1-4
1-5.	Conventions	1-5
1-6.	Specifications.....	1-6

1-1. Introduction

The Fluke 45 Dual Display Multimeter (also referred to as "the meter") is a 4-1/2-digit (30,000-count) meter with a 5-digit (100,000-count) high resolution mode designed for bench-top, field service, and system applications. The meter uses a dual vacuum-fluorescent display, allowing for two types of readings from a single input. Primary and secondary displays show the user-defined readings side by side. Even though the readings are made sequentially, the displays show both readings at all times for ease of comparison.

Some features provided by the meter are:

- Computer interface operation via the RS-232 interface (included) or the IEEE-488 interface (optional). The meter is fully programmable for use on the IEEE Standard 488.1 (1987). The meter is also designed in compliance with supplemental standard IEEE-488.2 (1987).
- True rms ac
- (AC + DC) rms, calculated
- Frequency measurements to greater than 1 MHz.
- 1 μ V sensitivity in volts dc
- Decibels with variable reference impedance and audio power measurement capability.
- A compare mode to determine if a measurement is within, above, or below a designated range.
- 100,000, 30,000, and 3,000 selectable count resolution, with reading speeds of 2.5, 5, and 20 readings per second (rps), respectively.
- Built-in self-tests with closed-case calibration (no internal adjustments).

1-2. Operating Instructions

Full operating instructions are provided in the Fluke 45 Users Manual. Reference to these instructions may be necessary during some of the maintenance and repair procedures presented in this Service Manual. For quick references, an operating instruction summary is presented on the inside of the front cover of the Service Manual. For more detailed information, refer to the Users Manual.

1-3. Options and Accessories

Three options are available. These options can be installed either at the factory or in the field. The following discussions pertain to the field-installable option kits:

- The Battery Kit (Option -01K) consists of a rechargeable, 8 V, lead-acid battery, with battery bracket and charger assembly. The battery has a typical operating time of eight hours and is fully operable at ambient temperatures between 0 and 50°C.
- The IEEE-488 Interface Kit (Option -05K) consists of a printed circuit assembly, connecting cables, and mounting hardware. This option provides full programmability, external trigger input, and automated calibration. The IEEE-488 computer interface command set is identical to the RS-232 interface commands wherever possible.
- Option -15K combines Options -01K and -05K as a single kit.

The Fluke 45 Dual Display Multimeter can be mounted in a standard 19-inch rack panel on either the right-hand or left-hand side using the Fluke M00-200-634 Rack Mount Kit.

Accessories for the Fluke 45 are listed in Table 1-1.

Table 1-1. Accessories

Model	Description
C40	Soft carrying case. Provides padded protection for the meter. Includes a pocket for the manual and pouch for the test leads and line cord.
M00-200-634	Rackmount Kit. Allows meter to be mounted on either the right or left side of a standard 19-inch rack.
RS40	RS-232 terminal interface cable. Connects other Fluke 45 to any terminal or printer with properly configured DTE connector (DB-25, female pins), including an IBM PC®, IBM PC/XT® or IBM PS/2 (models 25, 30, 50, P60, 70, and 80).
RS41	RS-232 modem cable. Connects the Fluke 45 to a modem.
S45	QuickStart™, a PC software package, simplifies operation of the Fluke 45 when using the RS-232 computer interface. Readings are recorded in files that can be accessed by Lotus 1-2-3®, dBase III® and other graphics packages.
Y8021	Shielded IEEE-488 one-meter (39.4 inches) cable, with plug and jack at each end.
Y8022	Shielded IEEE-488 two-meter (78.8 inches) cable, with plug and jack at each end.
Y8023	Shielded IEEE-488 four-meter (13 feet) cable, with plug and jack at each end.
QuickStart 45 is a trademark of Fluke Corporation. Lotus is a registered trademark of Lotus Development Co. dBase III is a registered trademark of Ashton-Tate. IBM PC and IBM PC/XT are registered trademarks of International Business Machines.	

1-4. Organization of the Service Manual

This manual focuses on component-level repair of the Fluke 45 Dual Display Multimeter. To that end, manual chapters are often interdependent; effective troubleshooting may require not only reference to the troubleshooting procedures in Chapter 5, but also some understanding of the detailed Theory of Operation in Chapter 2 and some tracing of circuit operation in the Schematic Diagrams presented in Chapter 9.

Often, scanning the table of contents will yield an appropriate place to start using the manual. A comprehensive table of contents is presented at the front of the manual; local tables of contents are also presented at the beginning of each chapter for ease of reference. If you know the topic name, the index at the end of the manual is probably a good place to start.

The following chapter descriptions serve to introduce the manual:

Chapter 1. Introduction and Specifications

Introduces the Fluke 45 Dual Display Multimeter, describing its features, options, and accessories. This chapter also discusses use of the Service Manual and the various conventions used in describing the meter's circuitry. Finally, a complete set of specifications is presented.

Chapter 2. Theory of Operation

This chapter first categorizes meter circuitry into functional blocks, with a description of each block's role in overall operation. A detailed circuit description is then given for each block. These descriptions explore operation to the component level and fully support troubleshooting procedures defined in Chapter 5.

Chapter 3. General Maintenance

Provides maintenance information covering handling, cleaning, and fuse replacement. Access and reassembly procedures are also explained in this chapter.

Chapter 4. Performance Testing and Calibration

This chapter provides performance verification procedures that are tied to the specifications presented in Chapter 1. To maintain these specifications, a full calibration procedure is also presented.

Chapter 5. Diagnostic Testing and Troubleshooting

The troubleshooting procedures presented in this chapter rely closely on both the Theory of Operation presented in Chapter 2 and the Schematic Diagrams shown in Chapter 9. Chapter 3 provides access information.

Chapter 6. List of Replaceable Parts

Includes parts lists for all standard assemblies. Information on how and where to order parts is also provided.

Chapter 7. Option -01 Battery Pack

Each option is allocated a separate chapter: 7 for the Battery Pack Option -01 and 8 for the IEEE-488 Interface Option -05. Option -15 incorporates both Options -01 and -05. Chapter 7 includes the full range of Service Manual topics (specifications, theory of operation, maintenance, list of replaceable parts, etc.) for the Battery Pack option. Schematic diagrams for the options are found in Chapter 9.

Chapter 8. Option -05 IEEE-488 Interface

Includes the full range of Service Manual topics (specifications, theory of operation, maintenance, list of replaceable parts, etc.) for the IEEE-488 Interface option. Schematic diagrams for the options are found in Chapter 9.

Chapter 9. Schematic Diagrams

Includes schematic diagrams for all standard and optional assemblies. A list of mnemonic definitions is also included to aid in identifying signal name abbreviations.

1-5. Conventions

Throughout the manual set, certain notational conventions are used. A summary of these conventions follows:

- Instrument Reference

The Fluke 45 Dual Display Multimeter is usually called the "meter."

- Printed Circuit Assembly

The term "pca" is used to represent a printed circuit assembly and its attached parts.

- Signal Logic Polarity

On schematic diagrams, a signal name followed by a "*" is active (or asserted) low. Signals not so marked are active high.

- Circuit Nodes

Individual pins or connections on a component are specified with a dash (-) following the component reference designator. For example, pin 19 of U30 would be U30-19.

- User Notation

For front panel operation,

XXX An uppercase word or symbol without parentheses indicates a button to be pressed by the user. Buttons can be pressed in four ways:

1. Press a single button to select a function or operation.
2. Press a combination of buttons, one after the other.
3. Press and hold down a button, then press another button.
4. Press multiple buttons simultaneously.

For computer interface operation,

XXX An uppercase word without parentheses identifies a command by name.

<XXX> Angle brackets around all uppercase letters mean press the<XXX> key.

(xxx) When associated with a keyword, a lowercase word in parentheses indicates an input required by the user.

1-6. Specifications

The following contains the specifications for the Fluke 45 Dual Display Multimeter. These specifications assume:

- A 1-year calibration cycle
- An operating temperature of 18 to 28°C
- Relative humidity not exceeding 90% (non-condensing)

Accuracy is expressed as \pm (percentage of reading + counts).

Reading Rates and Display Counts

Rate	Readings per Second	Full Range Display Counts
Slow	2.5	99,999*
Medium	5	30,000
Fast	20	3,000

* Ohms full range will typically be 98,000 counts

Response Times

Refer to Chapter 4 of the Users Manual for detailed information.

DC Voltage

Range	Resolution			Accuracy	
	Slow	Medium	Fast	(6 months)	(1 year)
300 mV	-	10 μ V	100 μ V	0.02% + 2	0.025%+2
3 V	-	100 μ V	1 mV	0.02% + 2	0.025% + 2
30 V	-	1 mV	10 mV	0.02% + 2	0.025%+2
300 V	--	10 mV	100 mV	0.02% + 2	0.025% + 2
1000 V	-	100 mV	1 V	0.02% + 2	0.025%+2
100 mV	1 μ V	-	-	0.02% + 6	0.025%+6
1000 mV	10 μ V	-	-	0.02% + 6	0.025% +6
10 V	100 μ V	-	-	0.02% + 6	0.025%+6
100 V	1 mV	-	-	0.02% + 6	0.025% +6
1000 V	10 mV	-	-	0.02% + 6	0.025%+6

Input Impedance

10 M Ω in parallel with <100 pF

Note

In the dual display mode, when the volts ac and volts dc functions are selected, the 10 M Ω dc input divider is in parallel with the 1 M Ω ac divider.

Normal Mode Rejection Ratio

- >80 dB at 50 or 60 Hz, slow and medium rates
- >54 dB for frequencies between 50-440 Hz, slow and medium rates
- >60 dB at 50 Hz, fast rate (Note: Fast rate has no filtering)

Maximum Allowable AC Voltage While Measuring DC Voltage

Range	Max Allowable Peak AC Voltage		Peak Normal Mode Signal	
			NMRR* >80dB**	NMRR >60 dB**
300 mV	100 mV	20 V	15 V	15 V
3 V	1000 mV	20 V	15 V	15 V
30 V	10 V	1000 V	50 V	300 V
300 V	100 V	1000 V	50 V	300 V
1000 V	1000 V	1000 V	200 V	1000 V

* NMRR is the Normal Mode Rejection Ratio
 ** Normal Mode Rejection Ratio at 50 or 60 Hz \pm 0.1%

Common Mode Rejection Ratio

>90 dB at dc, 50 or 60 Hz, (1 k Ω unbalanced, medium and slow rates)

Maximum Functional Input

1000 V dc or peak ac on any range

True Rms AC Voltage, AC-Coupled

Range	Resolution		
	Slow	Medium	Fast
300 mV	-	10 μ V	100 μ V
3 V	-	100 μ V	1 mV
30 V	-	1 mV	10 mV
300 V	-	10 mV	100 mV
750 V	-	100 mV	1 V
100 mV	1 μ V	-	-
1000 mV	10 μ V	-	-
10 V	100 μ V	-	-
100 V	1 mV	-	-
750 V	10 mV	-	-

Accuracy

Frequency	Linear Accuracy			dB Accuracy		Power*	Max Input at Upper Freq
	Slow	Medium	Fast	Slow/Med	Fast		
20-50 Hz	1% + 100	1% + 10	7% + 2	0.15	0.72	2% + 10	750 V
50 Hz -10 kHz	0.2% + 100	0.2% + 10	0.5% + 2	0.08	0.17	0.4% + 10	750 V
10 - 20 kHz	0.5% + 100	0.5% + 10	0.5% + 2	0.11	0.17	1% + 10	750 V
20 - 50 kHz	2% + 200	2% + 20	2% + 3	0.29	0.34	4% + 20	400 V
50 - 100 kHz	5% + 500	5% + 50	5% + 6	0.70	0.78	10% + 50	200 V

* Error in power mode will not exceed twice the linear accuracy specification

Accuracy specifications apply within the following limits, based on reading rate:

Slow Reading Rate: Between 15,000 and 99,999 counts (full range)

Medium Reading Rate: Between 1,500 and 30,000 counts (full range)

Fast Reading Rate: Between 150 and 3,000 counts (full range)

Decibel Resolution

Resolution	
Slow & Medium	Fast
0.01 dB	0.1 dB

Input Impedance

1 MΩ in parallel with <100 pF

Maximum Crest Factor

3.0

Common Mode Rejection Ratio

>60 dB at 50 or 60 Hz (1 kΩ unbalanced medium rate)

Maximum Input

750 V rms, 1000 V peak

2 x 10⁷ Volt-Hertz product on any range, normal mode input

1 x 10⁶ Volt-Hertz product on any range, common mode input

(AC + DC) Voltage Accuracy

Total Measurement Error will not exceed the sum of the separate ac and dc accuracy specifications, plus 1 display count. Refer to the table under "Maximum Allowable AC Voltage While Measuring DC Voltage or (AC + DC) Voltage" located on page 1-6.

Note

When measuring AC + DC, (or any dual display combination of AC and DC) in the fast reading rate, the Fluke 45 may show significant reading errors. This results from a lack of filtering on the DC portion of the measurement for the fast reading rate. To avoid this problem, use only the "slow" and "medium" reading rates for AC + DC or AC and DC combinations.

Maximum Frequency of AC Voltage Input While Measuring AC Current

When the meter makes ac current and ac voltage measurements using the dual display, the maximum frequency of the voltage input is limited to the maximum frequency of the current function. For example, if you are making an ac current measurement on the 10 A range, the maximum frequency of the voltage input must be less than 2 kHz.

DC Current

Range	Resolution			Accuracy	Burden Voltage*
	Slow	Medium	Fast		
30 mA	-	1 μA	10 μA	0.05% + 3	0.45 V
100 mA	-	10 μA	100 μA	0.05% + 2	1.4 V
10 A	-	1 mA	10 mA	0.2% + 5	0.25 V
10 mA	100 nA	-	-	.05% + 15	0.14 V
100 mA	1 μA	-	-	0.05% + 5	1.4 V
10 A	100 μA	-	-	0.2% + 7	0.25 V

*Typical at full range

Maximum Input

- mA 300 mA dc or ac rms. Protected with a 500 mA, 250 V, IEC 127-sheet I, fastblow fuse and a 440 mA, 1000 V, fast blow fuse.
- A 10 A dc ac rms continuous, or 20 A dc or ac rms for 30 seconds maximum. protected with a 11 A, 1000 V, 17,000 A interrupt rating, fast blow fuse.

Note

Resistance between the COM binding post and the meter's internal measuring circuits is approximately .003 Ω

AC Current

Range	Resolution			Burden Voltage*
	Slow	Medium	Fast	
10 mA	100 μA	-	-	0.14 V
30 mA	-	1 μA	10 μA	0.45 V
100 mA	1 μA	10 μA	100 μA	1.4 V
10 A	100 μA	1 mA	10 mA	0.25 V

* Typical at full range

Accuracy

Range	Frequency	Accuracy		
		Slow	Medium	Fast
mA (To 100 mA)	20-50 Hz	2% + 100	2% + 10	7% + 2
mA (To 100 mA)	50 Hz - 10 kHz	0.5% + 100	0.5% + 10	0.8% + 2
mA (To 100 mA)	10 - 20 kHz	2% + 200	2% + 20	2% + 3
A (1-10 A)	20 - 50 Hz	2% + 100	2% + 10	7% + 2
A (1 - 10 A)	50 Hz - 2 kHz	1% + 100	1% + 10	1.3% + 2
A (0.5 to 1 A)	20 - 50 Hz	2% + 300	2% + 30	7% + 4
A (0.5 to 1 A)	50 Hz - 2 kHz	1% + 300	1% + 30	1.3% + 4

mA accuracy specifications apply within the following limits, based on reading rate:

- Slow Reading Rate: Between 15,000 and 99,999 counts (full range)
- Medium Reading Rate: Between 1,500 and 30,000 counts (full range)
- Fast Reading Rate: Between 150 and 3,000 counts (full range)

Maximum Crest Factor

3.0

Maximum Input

- mA 300 mA dc or ac rms. Protected with a 500 mA, 250 V, IEC 127-sheet I, fast blow fuse and a 440 mA, 1000 V, fast blow fuse.
- A 10 A dc or ac rms continuous, or 20 A dc or ac rms for 30 seconds maximum. Protected with a 11 A, 1000 V, 17,000 A interrupt rating, fast blow fuse.

Note

Resistance between the COM binding post and the meter's internal measuring circuits is approximately .003 Ω.

Ohms

Range	Resolution			Accuracy	Typical Full Scale Voltage	Max Current Through the Unknown
	Slow	Medium	Fast			
300 Ω	-	10 mΩ	100 mΩ	0.05% + 2 + 0.02Ω	0.25	1 mA
3 kΩ	-	100 mΩ	1Ω	0.05% + 2	0.24	120 μA
30 kΩ	-	1 Ω	10 Ω	0.05% + 2	0.29	14 μA
300 kΩ	-	10 Ω	100 Ω	0.05% + 2	0.29	1.5 μA
3 MΩ	-	100 Ω	1 kΩ	0.06% + 2	0.3	150 μA
30 MΩ	-	1 kΩ	2%	0.25% + 3	2.25	320 μA
300 MΩ*	-	100 kΩ	1 MΩ	2%	2.0	320 μA
100 Ω	1 mΩ	-	-	0.05% + 8 + 0.02Ω	0.09	1 mA
1000 Ω	10 mΩ	-	-	0.05% + 8 + 0.02Ω	0.10	12 μA
10 kΩ	100 mΩ	-	-	0.05% + 8	0.11	14 μA
100 kΩ	1 Ω	-	-	0.05% + 8	0.11	1.5 μA
1000 kΩ	10 Ω	-	-	0.06% + 8	0.12	150 μA
10 MΩ	100 Ω	-	-	0.25% + 6	1.5	150 μA
100 MΩ	100 kΩ	-	-	2% + 2	2.75	320 μA

* Because of the method used to measure resistance, the 100 MΩ (slow) and 300 MΩ (medium and fast) ranges cannot measure below 3.2 MΩ and 20 MΩ, respectively. "UL" (underload) is shown on the display for resistances below these nominal points, and the computer interface outputs "+1E-9".

Open Circuit Voltage

3.2 volts maximum on the 100 Ω , 300 Ω , 30 M Ω , 100 M Ω , and 300 M Ω ranges, 1.5 volts maximum on all other ranges.

Maximum Rated Input (Input Protection)

1000 V dc or rms ac on all ranges

Diode Test/Continuity

	Maximum Reading	Resolution
Slow	999.99 mV	10 μ V
Medium	2.5 V	100 μ V
Fast	2.5 V	1 mV

Test Current

Approximately 0.7 mA when measuring a forward-biased junction.

Audible Tone

Continuous tone for continuity. Brief tone for normal forward biased diode or semiconductor junction.

Open Circuit Voltage

3.2 volts maximum

Continuity Capture Time

50 μ s maximum, 10 μ s typical

Maximum Rated Input (Input Protection)

1000 volts dc or rms ac

Frequency

5 Hz to > 1 MHz

Applicable Functions

Volts AC and Current AC

Range	Resolution		Accuracy
	Slow & Medium	Fast	
1000 Hz	.01 Hz	.1 Hz	.05% + 2
10 kHz	.1 Hz	1 Hz	.05% + 1
100 kHz	1 Hz	10 Hz	.05% + 1
1000 kHz	10 Hz	100 Hz	.05% + 1
1 MHz	100 Hz	1 kHz	*

* For measurement of 1 MHz and lower, accuracy is .05% + 1.
For measurement above 1 MHz, accuracy is not specified.

Sensitivity of AC Voltage

Frequency	Level (Sine Wave)
5 Hz - 100 kHz	30 mV rms
100 kHz - 300 kHz	100 mV rms
300 kHz - 1 MHz	1 V rms
Above 1 MHz	Not Specified

Sensitivity Level of AC Current

Frequency	Input	Level
5 Hz - 20 kHz	100 mA	>3 mA rms
45 Hz - 2 kHz	10 A	>3 A rms

Note

When the meter is set to measure frequency and there is no input signal (i.e., the input terminals are open), the meter may read approximately 25 kHz (rather than zero). This is due to internal capacitive pickup of the inverter power supply into the high-impedance, input circuitry. With source impedance of < 2 kΩ, this pickup will not affect the accuracy or stability of the frequency reading.

Environmental

Warmup Time

1 hour to rated specifications

Temperature Coefficient

<0.1 times the applicable accuracy specification per degree C for 0°C to 18°C and 28°C to 50°C

Electromagnetic Compatibility

In an RF field of 1 V/m on all ranges and functions:

Total Accuracy = Specified Accuracy + .4% of range. Performance above 1 V/m is not specified.

Operating Temperature

0°C to 50°C

Storage Temperature

40°C to + 70°C

Elevated temperature storage of battery will accelerate battery self-discharge. Maximum storage time before battery must be recharged:

20 - 25°C	1000 days
50°C	180 days
70°C	40 days

Relative Humidity

To 90% at 0°C to 28°C , (non condensing)

To 80% at 28°C to 35°C,

To 70% at 35°C to 50°C except to 70%

at 0°C to 50°C for the 1000 kΩ, 3 MΩ, 10 MΩ, 30 MΩ, 100 MΩ, and 300 MΩ ranges.

Altitude

Operating 0 to 10,000 feet

Non-operating 0 to 40,000 feet

Vibration

3 G @ 55 Hz

Shock

Half sine 40G. Per Mil-T- 28800D, Class 3, Style E.

Bench Handling. Per Mil-T-28800D, Class 3.

General

Common Mode Voltage

1000 V dc or rms ac maximum from any input to earth

Size

9.3 cm high, 21.6 cm wide, 28.6 cm deep

Weight

Net, 2.4 kg without battery; 3.2 kg with battery; Shipping, 4.0 kg without battery, 4.8 with battery.

Power

90 to 264 V ac (no switching required), 50 and 60 Hz. 15 VA maximum

Safety

Compliant with the following standards:

ANSI/ISA S82.01-1994

CAN/CSA-C22.2 No. 1010. 1-92

EN61010.1:1993 to 1000 V Overvoltage Cat I, 600 V Overvoltage Cat II

UL3111-1. See the following for an explanation of CAT I and CAT II categories.

CAT I:

OVERVOLTAGE (Installation) CATEGORY I, Pollution Degree 2 per IEC1010-1 refers to the level of Impulse Withstand Voltage protection provided. Equipment of OVERVOLTAGE CATEGORY I is equipment for connection to circuits in which measures are taken to limit the transient over voltages to an appropriate low level. Examples include protect electronic circuits.

CAT II:

OVERVOLTAGE (Installation) CATEGORY II, Pollution Degree 2 per IEC1010-1 refers to the level of Impulse Withstand Voltage protection provided. Equipment of OVERVOLTAGE CATEGORY II is energy-consuming equipment to be supplied from the fixed installation. Examples include household, office, and laboratory appliances.

Electromagnetic Compatibility

Meets FCC Part 15 Subpart J.

EN61326-1 (1998)

RS-232-C

Baud rates:

300, 600, 1200, 2400, 4800 and 9600

Odd, even or no parity One stop bit

Options

Battery (Option -01K)

Type

8 V, Lead-Acid

Operating Time

8 hours (typical).  lights when less than 1/2 hour of battery operation remains. Meter still meets specifications.

Recharge Time

16 hours (typical) with meter turned off and plugged into line power. Battery will not charge when meter is turned on.

IEEE-488 (Option -05K)

Capability Codes

SH1, AH1, T5, L4, SR1, RL1, PP0, DC1, DT1, E1, TE0, LE0 and C0 External Trigger
Input VIH 1.35 V minimum VIL 1.25 V maximum

Input Threshold Hysteresis

0.6 V minimum

Chapter 2

Theory of Operation

	Title	Page
2-1.	Introduction.....	2-3
2-2.	Functional Block Description.....	2-3
2-3.	Power Supply.....	2-3
2-4.	Analog Measurement Processor.....	2-3
2-5.	Input Protection Circuit.....	2-3
2-6.	Input Signal Conditioning.....	2-3
2-7.	Analog-to-Digital (A/D) Converter.....	2-3
2-8.	Serial Communication (Guard Crossing).....	2-3
2-9.	Digital Kernel.....	2-5
2-10.	Display Assembly.....	2-5
2-11.	IEEE-488 Interface Option (-05).....	2-5
2-12.	Battery Pack Option (-01).....	2-5
2-13.	Detailed Circuit Description.....	2-5
2-14.	Power Supply Circuit Description.....	2-5
2-15.	Raw DC Supply.....	2-6
2-16.	5-Volt Switching Supply.....	2-6
2-17.	Inverter.....	2-7
2-18.	Analog Measurement Processor.....	2-7
2-19.	Input Protection.....	2-10
2-20.	Input Signal Conditioning.....	2-10
2-21.	Relays.....	2-11
2-22.	DC Volts.....	2-12
2-23.	Ohms.....	2-12
2-24.	100 M Ω and 300 M Ω Ranges.....	2-14
2-25.	AC Volts.....	2-14
2-26.	DCmA.....	2-15
2-27.	ACmA.....	2-15
2-28.	Amps.....	2-15
2-29.	Diode/Continuity Test.....	2-15
2-30.	Frequency.....	2-15
2-31.	Active Filter.....	2-16
2-32.	A/D Converter.....	2-17
2-33.	Serial Communication (Guard Crossing).....	2-18
2-34.	Digital Kernel.....	2-18
2-35.	RS-232 Interface.....	2-19

2-36.	Microprocessor	2-19
2-37.	EEROM.....	2-19
2-38.	RAM.....	2-20
2-39.	ROM.....	2-20
2-40.	IEEE-488 Option Connections.....	2-20
2-41.	Display Assembly.....	2-20
2-42.	Main Assembly Connector.....	2-20
2-43.	Front Panel Switches.....	2-20
2-44.	Display	2-21
2-45.	Beeper Drive Circuit	2-21
2-46.	Watchdog Timer and Reset Circuit.....	2-21
2-47.	Display Controller with FIP	2-22

2-1. Introduction

This chapter presents a layered description of Fluke 45 circuitry. First, the multimeter is described in general terms with a Functional Block Description. Then, each block is detailed further (often to the component level) with Detailed Circuit Descriptions. Refer to Chapter 9 of this manual for full schematic diagrams.

Signal names followed by a '*' are active (asserted) low. Signal names not so marked are active high.

2-2. Functional Block Description

Refer to Figure 2-1, Overall Functional Block Diagram, during the following functional block descriptions.

2-3. Power Supply

The Power Supply functional block provides voltages required by both the vacuum-fluorescent display (-30 V dc, -5.2 V dc, and 5 V ac) and the in-guard circuitry (-5.25 V dc and 5.25 V dc). Within the Power Supply, the Raw DC Supply converts ac line voltage to dc levels and the 5 V Switching Supply converts this raw dc to 5 V \pm 0.25 V dc, which is used by the Inverter in generating the above-mentioned outputs.

2-4. Analog Measurement Processor

The Analog Measurement Processor (A1U1) provides input signal conditioning, ranging, a/d conversion, and frequency measurement. This custom chip is controlled by the Main Processor (A1U6), with communication carried out over a special serial interface.

2-5. Input Protection Circuit

Input protection safeguards the meter against a number of over-voltage and over-current conditions. Depending on the type of input, protection circuits or fuses are used.

2-6. Input Signal Conditioning

The input signal (voltage, current, or resistance) must be scaled or conditioned to a dc voltage that can be measured by the a/d converter. High dc voltage levels must be attenuated. Resistances, currents, and ac voltages must be converted to a representative dc voltage. DC-type measurements (dc volts, dc current, ohms, and diode test) are then filtered by an active filter. AC measurements (ac volts and ac current) are passively filtered after being converted to a dc voltage.

2-7. Analog-to-Digital (A/D) Converter

The voltage level from the signal conditioning circuits charges (or integrates) a capacitor for an exact amount of time. The capacitor discharge time, which is proportional to the level of the unknown input signal, is measured by the digital circuits in the Analog Measurement Processor and sent to the microprocessor.

2-8. Serial Communication (Guard Crossing)

This functional block provides a high isolation voltage communication path between the Digital Kernel and the Analog Measurement Processor. This bi-directional communication circuit also requires power supply voltages from the Power Supply block.

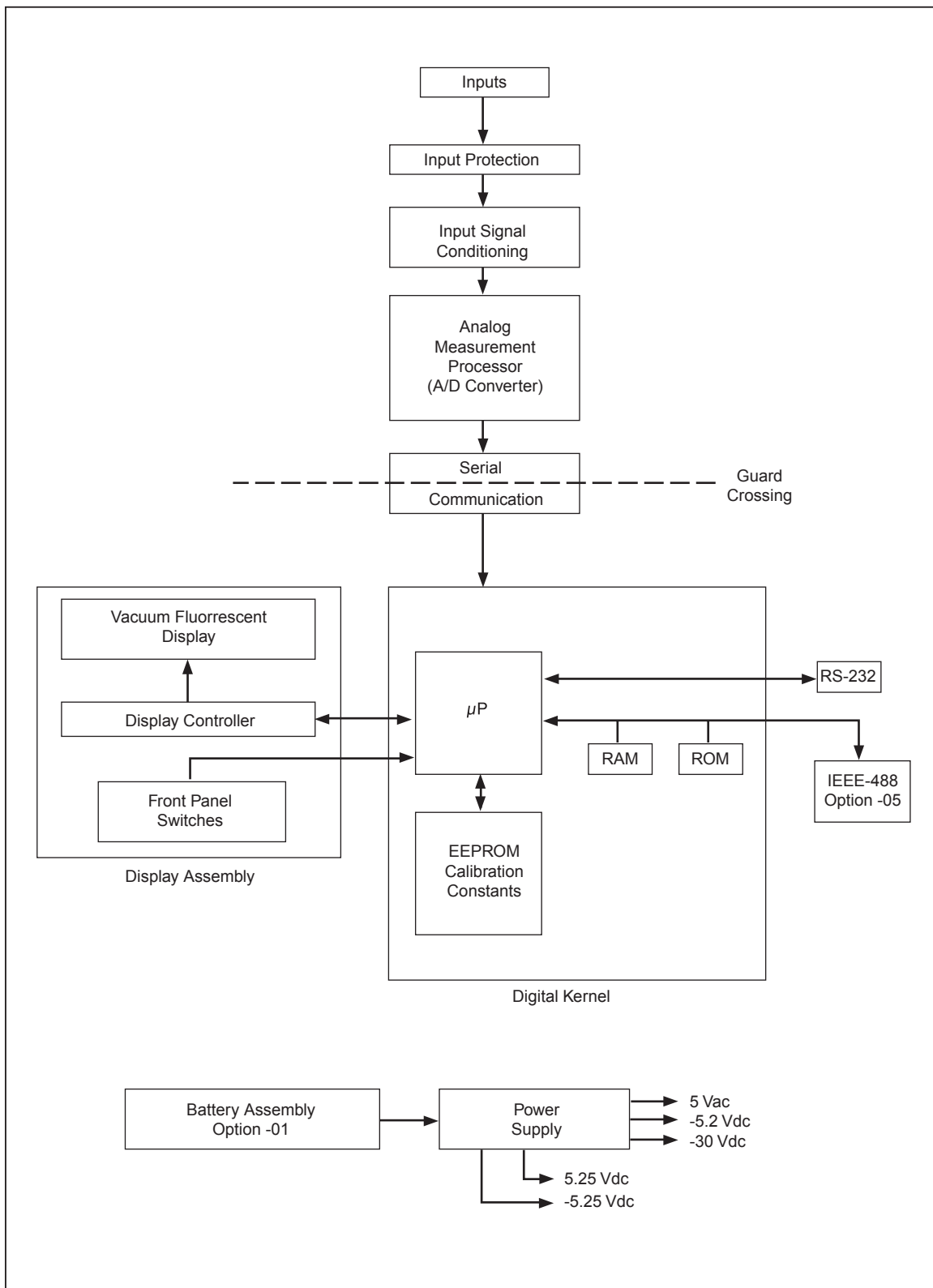

Figure 2-1. Overall Functional Block Diagram

qb01.eps

2-9. Digital Kernel

The Digital Kernel functional block is responsible for the coordination of all activities within the meter. This block requires power supply voltages from the Power Supply and reset signals from the Display Assembly.

Specifically, the Digital Kernel Microprocessor performs the following functions:

- Executes the instructions in ROM
- Stores temporary data in RAM
- Store meter configuration and calibration data in EEROM
- Communicates with the Analog Measurement Processor via the Serial Communication (Guard Crossing) block
- Communicates with the Display Controller to display readings and user interface information
- Scans the user interface keyboard found on the Display Assembly
- Communicates via the RS-232 interface and optional IEEE-488 interface.

2-10. Display Assembly

The Display Assembly controller communicates with the main Microprocessor over a three-wire communication channel. Commands from the Microprocessor inform the Display Controller how to modify its internal display memory. The Display Controller then drives the grid and anode signals to illuminate the required segments on the Display. The A2 Display Assembly requires power supply voltages from the Power Supply and a clock signal from the A1U6 Microprocessor.

2-11. IEEE-488 Interface Option (-05)

Theory of operation for the IEEE-488 Interface Option (-05) is presented in Chapter 8 of this manual. The related schematic diagram is found in Chapter 9.

2-12. Battery Pack Option (-01)

Chapter 7 of this manual contains the theory of operation for the Battery Pack Option (-01). Refer to Chapter 9 for the related schematic diagram.

2-13. Detailed Circuit Description

2-14. Power Supply Circuit Description

The Power Supply consists of the following three functional sections:

- Raw DC Supply
The Raw DC Supply converts line voltage (90 V to 264 V ac) to a dc output of 7.5 V to 5 V.
- 5 V Switching Supply
The 5 V Switching Supply converts the Raw DC Supply output to 5.1 V \pm 0.25 V dc.
- Inverter
Using the 5 V Switching Supply output, the Inverter generates the -30 V dc, -5 V dc, and 5 V ac supply levels needed for the vacuum-fluorescent display. Also, the

Inverter provides isolated positive and negative 5.25 V outputs for the in-guard circuitry.

2-15. Raw DC Supply

The Raw DC Supply uses a power transformer (A1T3) that operates on input line voltages ranging from 90 V to 264 V ac. Since there is no power switch in the transformer input circuit, the Raw DC Supply is energized whenever the meter is connected to line power. The transformer uses an internal 275 V ac MOV (metal-oxide varistor) to clamp line transients. This MOV normally acts as an open circuit; when the peak voltage exceeds approximately 400 V, the MOV turns on and, working with the line impedance in series with the line fuse, limits the transient peak voltage to 400 to 500 V. All line voltages use a T 0.125 A, 250 V (slow blow) fuse.

On the secondary side of the transformer, the output is rectified by diodes A1CR2 and A1CR3 and filtered by capacitor A1C27. In addition, A1C26 reduces rectifier diode switching emi emissions from the meter. The meter power switch (A1S1) is also connected in the output of the Raw DC Supply; it connects the Raw DC Supply either to the 5-V Switching Supply (when the meter is ON) or to the Battery Charger Switching Supply through A1J1-7 (when the meter is OFF.)

2-16. 5-Volt Switching Supply

The 5-Volt Switching Supply incorporates the A1U11 controller device and several external components. Operating on an input of 7.5 V dc to 35 V dc, the 5-volt Switching Supply uses a pulse-width modulation technique to regulate its output at 5.1 V dc. The nominal switching frequency is 40 kHz.

With the controller, the output voltage is controlled by varying the duty cycle (ON time) of the switch transistor in A1U11. (Controller device A1U11 contains the supply reference, oscillator, switch transistor, pulse-width modulator comparator, switch drive circuit, current-limit comparator, and current-limit reference.) Resistors A1R41 and A1R42, in conjunction with the reference circuit, set the input levels to the pulse-width modulating comparator. Resistors A1R35 (in parallel with A1R41) and A1R36 (in parallel with A1R42) are used in production to adjust the 5.1 V supply output. Removing A1R35 decreases the output by approximately 5%. Removing A1R36 increases the output by approximately 7%.

Within the controller, the output of the comparator is combined with the oscillator signal to form the drive signal for the switch transistor. Diode A1CR6 operates as a complementary switch with the switch transistor. Dual inductor A1T1 is a magnetic device that regulates current pulses as the switch transistor is turned on and off. A current shunt (A1R47, A1R48, and A1R49) senses the overall current flowing through diode A1CR5 and the switch transistor of A1U11. If this current rises too high, the duty cycle (ON time) of the switch transistor is reduced to current-limit the supply. Capacitor A1C33 serves as a filter capacitor and energy storage device, and A1C34 and A1C35 are the output filter capacitors.

The boost circuit (A1CR4 and A1C32) supplies the controller A1U11 with sufficient supply voltage when the switching supply input is low. For example, this condition may occur when the meter is operating on low line voltage.

Resistor A1R40 and capacitors A1C28 and A1C29 are needed for proper dynamic performance of the switching supply. Capacitor A1C30 sets the operating frequency of the supply.

2-17. Inverter

The inverter uses transistors A1Q10, A1Q11, A1Q12, and A1Q13 connected to form an astable 30-kHz multivibrator. The operating frequency and drive to the transistors are determined by the values of the interconnecting resistors and capacitors. The inverter transformer (A1T2) primary is connected across the collectors of the multivibrator transistors; the primary winding is thereby driven by a symmetrical square wave. Resistor A1R46 and capacitor A1C41 form a filter network to reduce the amplitude of current pulses generated by the switching of the inverter transistors.

The secondary windings of A1T2 are used for three sets of supply voltages. The first winding of the A1T2 secondary provides out-guard outputs using the following rectifier diodes and filter capacitors to provide the required voltages for the display and the battery trickle charger circuit.

- A1CR11 and A1C45: -30 V supply
- A1CR12 and A1C47: -5 V supply
- A1CR10 and A1C46: +30 V source for the battery trickle charger.

Next, an isolated secondary winding provides the various in-guard supplies. Dual diodes A1CR8 and A1CR9 and capacitors A1C43 and A1C44 are the rectifiers and filters for the in-guard +5.25 V and -5.25 V supplies. Dual diode A1CR7 and capacitor A1C42 are the rectifier and capacitor for the relay (5.25 V dc) supply.

A third transformer winding provides the heater power (FIL1, FIL2) for the vacuum-fluorescent display. Zener diode A1VR3 and resistor A1R55 bias this winding at approximately 5 volts more positive than the -30 V supply.

2-18. Analog Measurement Processor

Refer to Figure 2-2 for an overall picture of the Analog Measurement Processor chip and its peripheral circuits. Table 2-1 describes Analog Measurement Processor chip signal names.

The Analog Measurement Processor (A1U1) is a 68-pin CMOS device that, under control of the Main Processor (A1U6), performs the following functions:

- Input signal routing
- Input signal conditioning
- Range switching
- Active filtering of dc-type measurements. The active filter is disabled for fast reading rate measurements.
- A/D conversion
- Support for direct volts, direct current, true rms alternating volts, true rms alternating current, ohms, frequency, and continuity/diode test functions.

Two separate signal paths are used, one for dc/ohms and one for ac. For dc, the 3 V range and below are coupled directly to the a/d converter; higher voltages are attenuated. For ohms, the dc circuitry is augmented with an internal ohms source voltage regulator controlled through an extra set of switches. For ac, inputs are routed through the ac buffer, with attenuation being controlled by the a/d converter.

The a/d converter uses a modified dual-slope minor cycle method. The basic measurement unit, a minor cycle, consists of a fixed time integrate period for the unknown input, a variable reference integrate period, a variable hold period, and various short transition periods. A minor cycle period equals 25 ms.

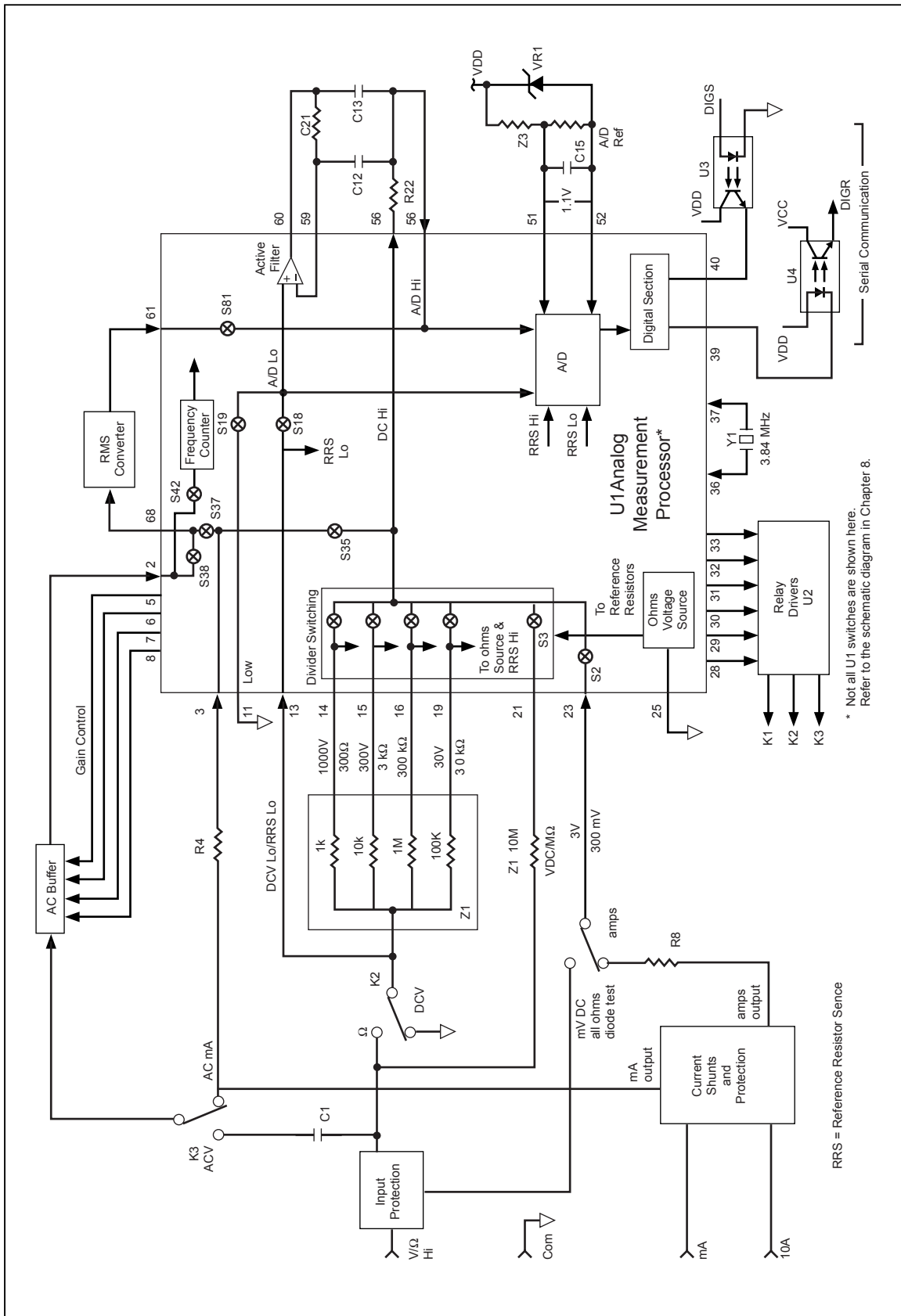

* Not all U1 switches are shown here. Refer to the schematic diagram in Chapter 8.

RRS = Reference Resistor Sense

Figure 2-2. Analog Simplified Schematic Diagram

qb02f.eps

Table 2-1. Analog Measurement Processor Pin Name Description

Pin	Name	Description
1	VDD	+5 V supply
2	ACBO	AC buffer output
3	AIN	Amps input
4	AGND2	Analog ground #2
5	ACR4	AC buffer range 4
6	ACR3	AC buffer range 3
7	ACR2	AC buffer range 2
8	ACR1	AC buffer range 1
9	VSSACR	-5 V supply for AC ranging
10		(not used)
11	LO	A/D converter low input
12	GRD	Guard
13	RRS	Reference resistor sense for ohms
14	V4	Tap #4 on the DCV input divider/ohms reference network
15	V3	Tap #3 on the DCV input divider/ohms reference network
16	V1	Tap #1 on the DCV input divider/ohms reference network
17	GRD	Guard
18	V2F	Tap #2 active filter input on the DCV input divider/ohms reference network
19	V2	Tap #2 on the DCV input divider/ohms reference network
20	GRD	Guard
21	V0	Tap #0 on the DCV input divider/ohms reference network
22	GRD	Guard
23	OVS	Ohms and volts sense input
24	GRD	Guard
25	AGND1	Analog ground #1
26		(not used)
27	DGND	Digital ground
28	FC0	Function control #0
29	FC1	Function control #1
30	FC2	Function control #2
31	FC3	Function control #3
32	FC4	Function control #4
33	FC5	Function control #5
34	FC6	(not used)
35	FC7	(not used)
36	OSCIN	Crystal oscillator input
37	OSCO	Crystal oscillator output
38	MRST	Master reset
39	AS	Analog send
40	AR	Analog receive
41	SK	Serial clock
42	CS	Chip select
43	BRS	Baud rate select
44	VSS	-5 V
45	INT	Integrator output
46	SUM	Integrator summing node
47	B.1	Buffer output, 100 mV range
48	B.3	Buffer output, 300 mV range
49	B1	Buffer output, 1000 mV range
50	B3	Buffer output, 3 V range

Table 2-1. Analog Measurement Processor Pin Name Description (cont)

Pin	Name	Description
51	VREF+	A/D reference plus
52	VREF-	A/D reference minus
53	RAO	A/D reference amplifier output
54	RA+	A/D reference amplifier noninverting input
55	RA-	A/D reference amplifier inverting input
56	AFO	Active filter output
57	MOF	Megohms filter
58	AFI	Active filter input
59	FAI	Filter amplifier inverting input
60	FAO	Filter amplifier output
61	RMSF	RMS output, filtered
62	ARTN	Analog return
63		(not used)
64	RMSO	RMS converter output
65	BIAS2	Bias input
66	VSSF	-5 V dc, filtered
67	BIAS1	Bias input
68	RMSI	RMS converter input

2-19. Input Protection

Input protection safeguards the meter against a number of over-voltage and over-current conditions. The various input protection schemes are as follows:

- In the Voltage mode of operation, MOVs A1RV1, A1RV2 and A1RV3 clamp input voltage transients to about 1800 volts, and A1R5, A1RT1 and A1R6 limit the current. In this mode, A1R7 and the 10-M Ω resistor in A1Z1 protect A1U1.
- In the Ohms and Diode Test modes, A1Q1 clamps voltage inputs of both polarities, and A1R5 and thermistor A1RT1 limit the overload current. With large overloads, A1RT1 heats up and increases in resistance. Components A1R9 and A1Z1 protect A1U1.
- The [100 mA] input is protected by fuses F1 and F5. With this input, A1R4 protects A1U1.
- The [10 A] input is protected by fuse A1F2, with A1R8 protecting A1U1.

2-20. Input Signal Conditioning

The input signal (voltage, current, or resistance) must be scaled or conditioned to a form that can be measured by the a/d converter. High dc voltage levels must be attenuated. Resistances, currents, and ac voltages must be converted to a representative dc voltage. DC-type measurements (dc volts, dc current, ohms, and diode test) are then filtered by the active filter. AC measurements (ac volts and ac current) are passively filtered after being converted to a dc voltage. In the medium and fast measurement rates, the a/d converter uses one of two ranges: ± 300 mV and ± 3 V full scale. In the slow rate, the a/d converter uses one of two additional ranges (± 100 mV and ± 1000 mV full scale), for a total of four ranges.

2-21. Relays

Latching relays A1K1, A1K2, and A1K3 route and connect the input signal to the functional blocks required by the selected function. The Analog Measurement Processor (A1U1) function control outputs, which are 8-ms positive pulses (0 V to VDD) at FC0 to FC5 (pins 28 to 33), control the relay driver, A1U2. The A1U2 drivers are NPN Darlingtons. Relay functions are defined in Table 2-2.

Table 2-2. Relay Operation

Function	Relays		
	A1K	A1K2	A1K3
DC mV, 3 V	Reset	Set	Set
DC 10 V, 30 V, 100 V, 300 V, 1000 V	Set	Set	Set
ACV	Set	Set	Reset
Ohms & k ohms	Reset	Reset	Set
M ohms	Reset	Set	Set
Diode Test	Reset	Reset	Set
mA DC and ADC	Set	Set	Reset
mA AC and AAC	Set	Set	Set
Frequency	Set	Set	Reset

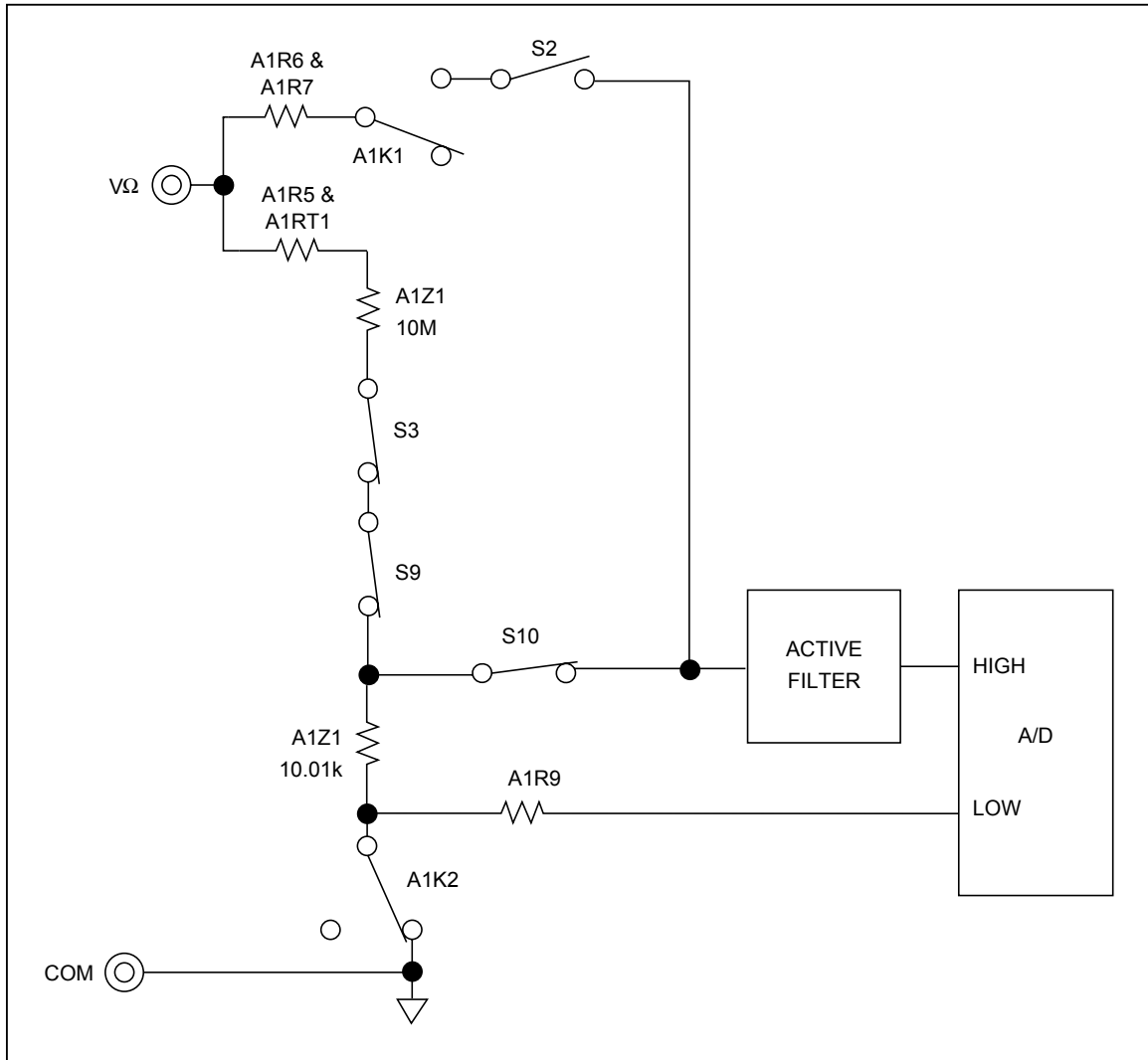

qb03f.eps

Figure 2-3. DC Volts 300 V Range Simplified Schematic

2-22. DC Volts

For the mV and 3 V ranges, the input signal is applied to A1U1 through A1R6, A1R7, and A1K1. The signal is routed directly through A1U1 to the active filter and the a/d converter without attenuation. Higher voltages are attenuated by the dc input divider A1Z1.

For the 300 V range, switches S3 and S9 in A1U1 connect the A1Z1 10-M Ω resistor to the A1Z1 10.01-k Ω resistor, forming a 1000:1 divider. See Figure 2-3. The S10 switch in A1U1 routes the signal to the active filter. Pin 3 of A1Z1 serves as divider common, which is also the a/d converter low signal sensed through A1R9.

2-23. Ohms

Resistance measurements are made using the ratio ohms technique. See Figure 2-4. A voltage source is connected in series with the reference resistor (A1Z1) and the unknown resistor. Since the same current then flows through both resistors, the unknown resistance is determined from the ratio of the voltage drops across the reference and unknown resistors.

Depending on the range, S3, S6, S9, S13, or S15 connects the Analog Measurement Processor ohms voltage source to a reference resistor. The resulting current passes through the reference resistor, A1K2, the protection resistors A1RT1 and A1R5, and the unknown resistance. The a/d converter integrates with the voltage across the unknown through the OVS input (pin 23). For DE- integrate reference, the a/d converter uses the voltage across the reference resistor through RRS (pin 13) and Ohms Reference High through S5 (pin 21), S14 (pin 19), S17 (pin 16), S11 (pin 15) or S8 (pin 14). Reference resistances are identified in Table 2-3.

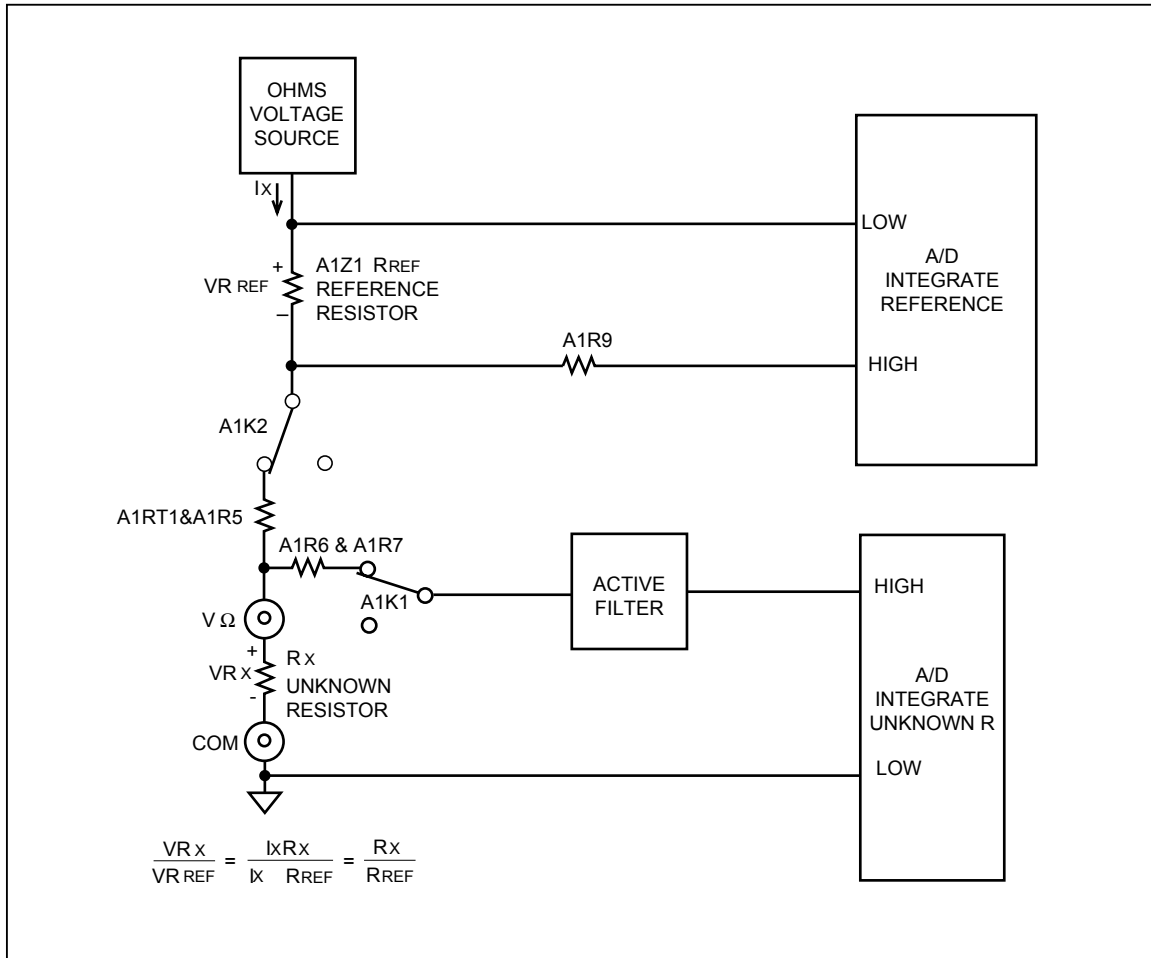

qb04f.eps

Figure 2-4. Ohms Simplified Schematic

Table 2-3. Reference Resistance

Range	Voltage Source	A1Z1 Reference Resistor
100 Ω /300 Ω	3 V	1 kΩ
1000 Ω/3 kΩ	1.3 V	10.01 kΩ
10 kΩ/30 kΩ	1.3 V	100.5 kΩ
100 kΩ/300 kΩ	1.3 V	1 MΩ
1000 kΩ/3 MΩ/10 MΩ	1.3 V	10 MΩ
30 MΩ	3 V	10 MΩ
100 MΩ/300 MΩ	3 V	10 MΩ
Diode Test	3 V	1 kΩ

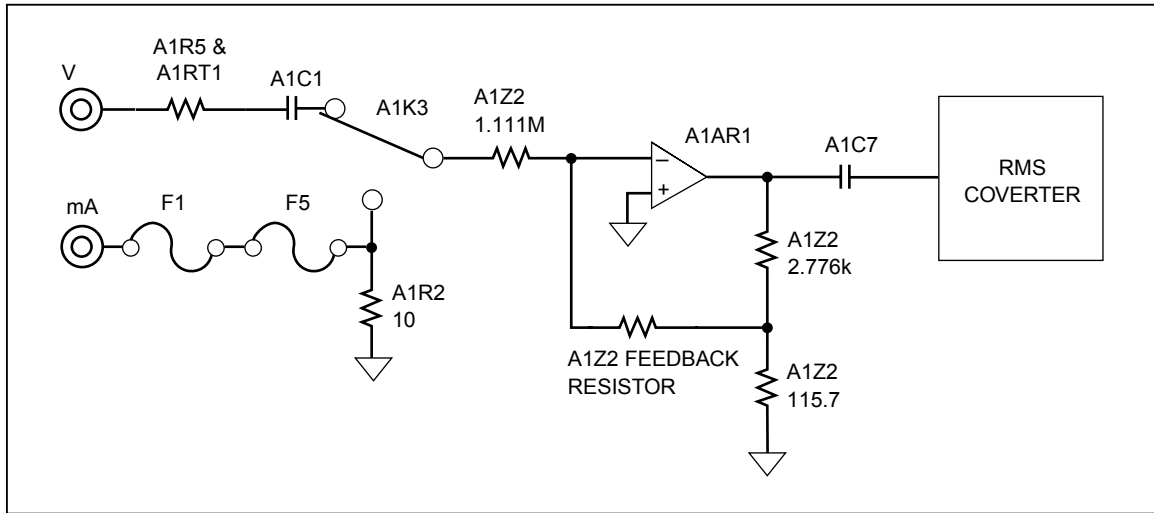

Figure 2-5. AC Buffer Simplified Schematic

Table 2-4. AC Volts Input Signal Dividers

Range (Drive Signal)	A1Z2 Feedback Resistor	Overall Gain
100/300 mV (ACR1)	111.1 k Ω	2.5
1000 mV/3 V (ACR2)	12.25 k Ω 111.1 k Ω	.25
10/30 V (ACR3)	1.013 k Ω 111.1 k Ω	.025
100/300/750 V (ACR4)	2.776 k Ω	.0025

2-24. 100 M Ω and 300 M Ω Ranges

The 100 M Ω and 300 M Ω ranges perform a conductance reading; the mathematical reciprocal of this reading is used as a display in ohms. The reference resistor (A1Z1, 10 M Ω) is integrated first, then the unknown resistance is used for DE- integrate reference.

2-25. AC Volts

AC voltage and ac current inputs are scaled by the ac buffer, then converted to a representative dc voltage by the true rms ac-to-dc converter.

Refer to Figure 2-5. JFETs A1Q2 to A1Q8 switch the ranges of the buffer amplifier A1AR1. The JFET drive signals, ACR1 to ACR4 (pins 5 to 8) turn the JFETs either on at 0 V or off at -VAC. The ratio of the feedback resistor to the 1.111-M Ω input resistor divides the input signal by 10, 100, or 1000. These arrangements are summarized in Table 2-4. This signal is then amplified by 25 using the 2.776-k Ω and 115.7 Ω buffer output divider resistors. The A1Z2 111.1-k Ω feedback resistor is left in parallel with the higher range feedback resistors. For the 300/750 V range, the 2.776-k Ω resistor becomes the feedback element. A1R15 and A1C2 compensate the 300-mV range of the ac buffer.

The ac signal is then routed to the rms converter by Analog Measurement Processor switch S38. Capacitors A1C1, A1C7, A1A1C2, and A1A1C3 function as dc blocking capacitors. A1A1R1 provides input bias current for the rms converter buffer, and A1A1C1 is the converter's averaging capacitor.

The rms converter output is divided down by 2.5 by A1Z4; A1R19 and A1C10 form the passive filter for ac volts. Analog Measurement Processor switch S80 shorts A1R19 both during ranging and in the fast measurement rate. Components A1R16, A1R17, A1C3,

A1C4, A1C5, and A1C6 provide a filtered power supply for the ac buffer, the ac buffer switching JFETs, and the rms converter.

2-26. DCmA

Current through A1R2 develops a voltage that is proportional to the input. This dc voltage is routed through A1R4 to the active filter, then to the a/d converter. The 100 mA current range uses the 3 V range of the a/d converter. See Figure 2-6.

2-27. ACmA

In ACmA, relay A1K3 connects the ac voltage developed across A1R2 to the ac buffer. The signal is then conditioned as described for ac volts.

2-28. Amps

The dc voltage output of the 10 amp shunt (A1R3) is routed directly to the a/d converter through the Analog Measurement Processor OVS input (pin 23). For ac amps, the ac voltage output of the shunt is routed to the rms converter through Analog Measurement Processor switches S35 and S37.

2-29. Diode/Continuity Test

In Diode Test, the meter front end is in the 300 ohm range configuration. The a/d converter measures the dc voltage at the binding posts through the OVS input (pin 23).

For the continuity function, the frequency/continuity comparator senses the signal through Analog Measurement Processor switches S35 and S41. The comparator toggles when the input goes below about 20 mV.

2-30. Frequency

The frequency/continuity comparator uses the ac volts/ac mA output of the ac buffer as its input at the Analog Measurement Processor ACBO input (pin 2). In the 10 A ac range, the signal is routed to the comparator through Analog Measurement Processor switches S35 and S41.

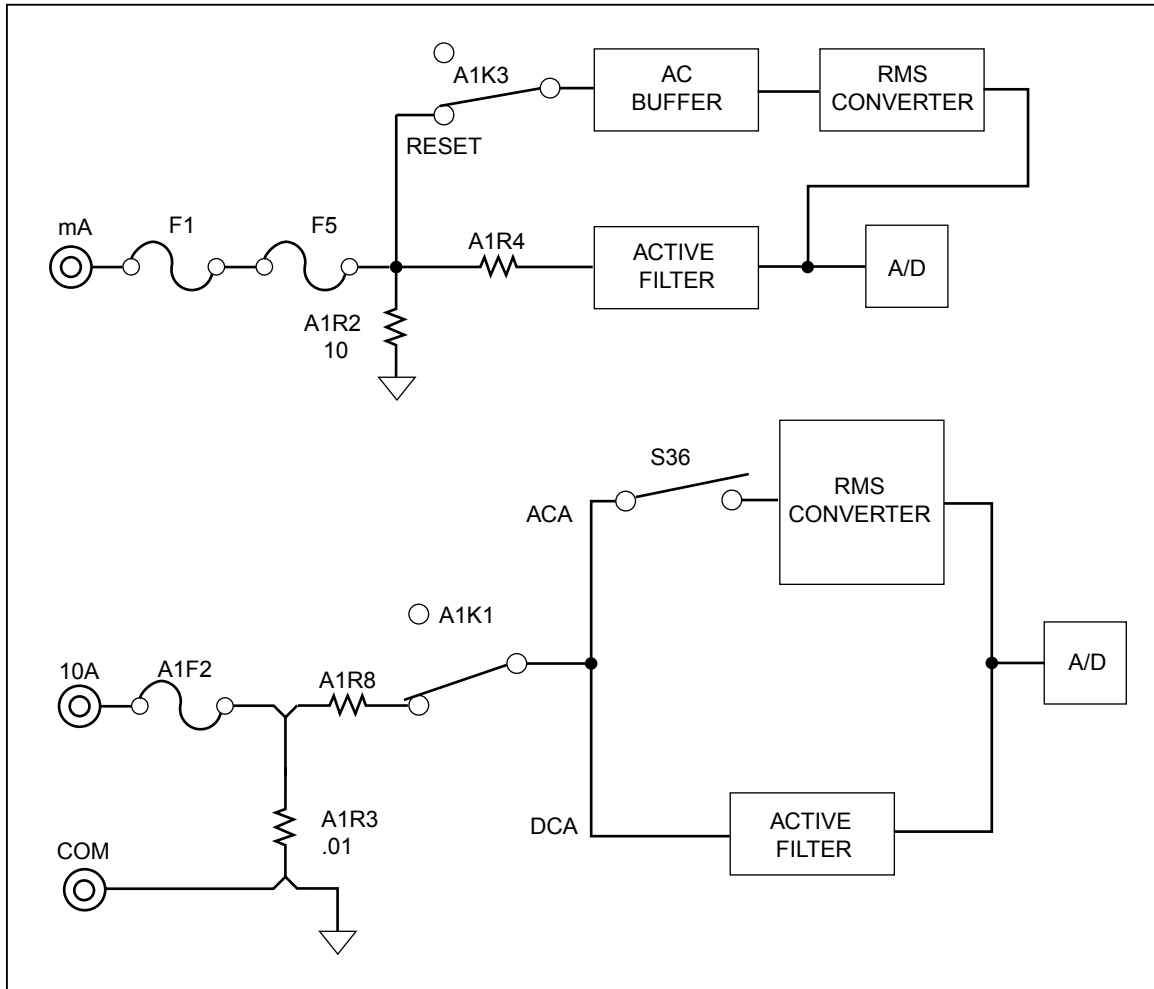

qb06f.eps

Figure 2-6. DC mA and Amps Simplified Schematic

2-31. Active Filter

Refer to Figure 2-7. The two-pole active filter consisting of A1R21, A1R22, A1C12, and A1C13 filters noise on the a-d converter input signal for the DCV, DCmA, DCA, OHMS, kOHMS, and Diode Test functions. Resistor A1R22 provides a 200-k Ω input impedance for the filter, except as follows:

- Resistors A1R6 and A1R7 provide the 200-k Ω input impedance for the 100 mV dc, 300 mV dc, 1000 mV dc, 3 V dc, ohms, and kilohms ranges.
- Resistor A1R10 and the 100.5 k Ω resistor in A1Z1 provide the 200 k Ω impedance for the 10 V and 30 V dc ranges.
- Resistor A1R4 provides the impedance for the two DCmA ranges.

Analog Measurement Processor switch S82 shorts out A1R21 during ranging. Switch S87 shorts out A1R22 both during ranging and in the measurements listed above. For the 1000 k Ω , 3 M Ω , 10 M Ω , 30 M Ω , 100 M Ω , and 300 M Ω ranges, the active filter is bypassed, and switch S83 selects C14 as the filter.

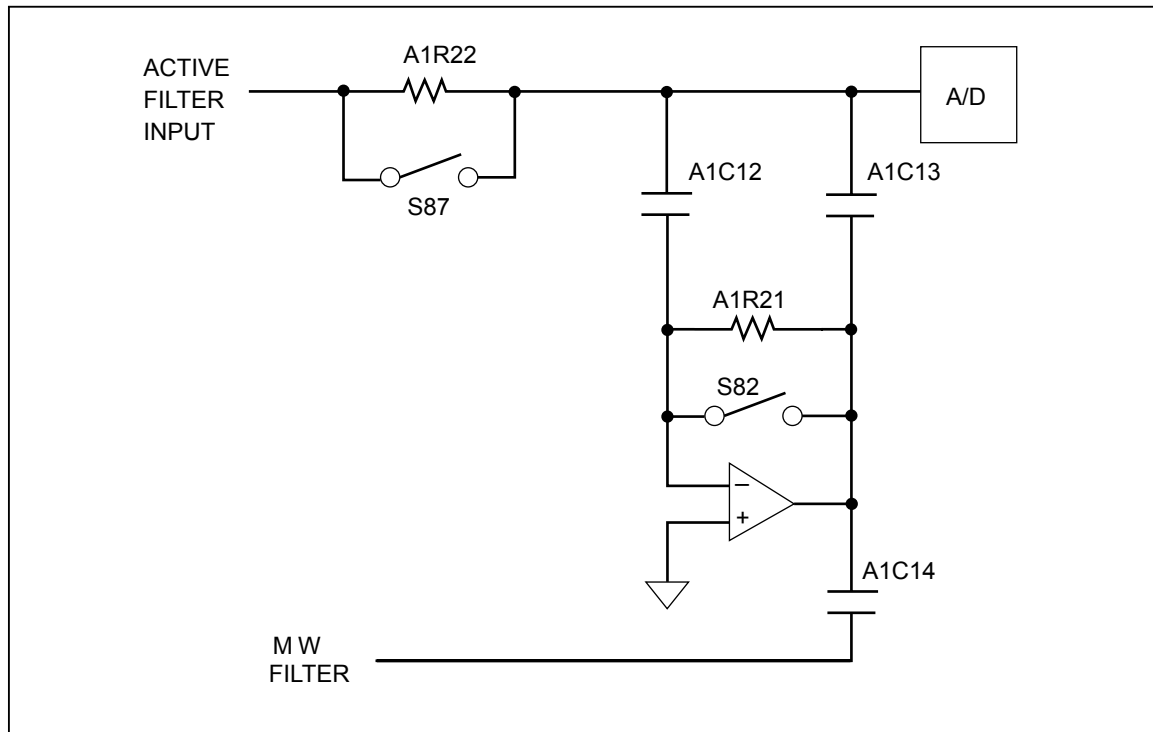

Figure 2-7. Active Filter Simplified Schematic

qb07f.eps

2-32. A/D Converter

Figure 2-8 shows the dual slope a/d converter used in the Fluke 45. A voltage level proportional to the unknown input signal charges (integrates) a capacitor for an exact amount of time. This capacitor is then discharged by a reference voltage of opposite polarity. The capacitor discharge time, which is proportional to the level of the unknown input signal, is measured by the digital circuits in the Analog Measurement Processor and sent to the microprocessor.

In the medium and fast measurement rates, the a/d converter uses the ± 300 mV or ± 3 V range. These ranges typically uprange at a display of 32,000 in the medium rate. In the slow rate, the a/d converter uses one of two additional ranges: ± 100 mV and ± 1000 mV. The uprange point for these additional ranges is a display of 99,999. In the ohms function only, a typical uprange point is a display of about 98,000.

During the integrate phase, the a/d buffer in Analog Measurement Processor A1U1 applies the signal to be measured to one of the four integrate resistors in resistor network A1Z3. The choice of resistor depends on the measurement range. Switch S69 connects output B.1 (pin 47) for the 100-mV range; S71 uses output B.3 (pin 48) for the 300-mV range; S73 uses output B1 (pin 49) for the 1000 mV range; and S75 uses output B3 (pin 50) for the 3 V range. Refer to Figure 8-1.

The current through the selected integrator resistor charges integrator capacitor A1C16. After the integrate phase, the buffer applies the opposite polarity reference voltage, and the integrator integrates back down until the comparator toggles. A counter measures the integrate reference time. If the a/d converter is overloaded and the integrator does not return to its starting point by the end of the integrate reference phase, S77 discharges integrator capacitor A1C16.

The reference voltage for volts, current, and diode test modes is provided by a 6.3 V zener diode, A1VR1. The reference amplifier in the Analog Measurement Processor

provides 2 mA of current through A1VR1. Resistor network A1Z3 divides the 6.3 V down to 1.1 V.

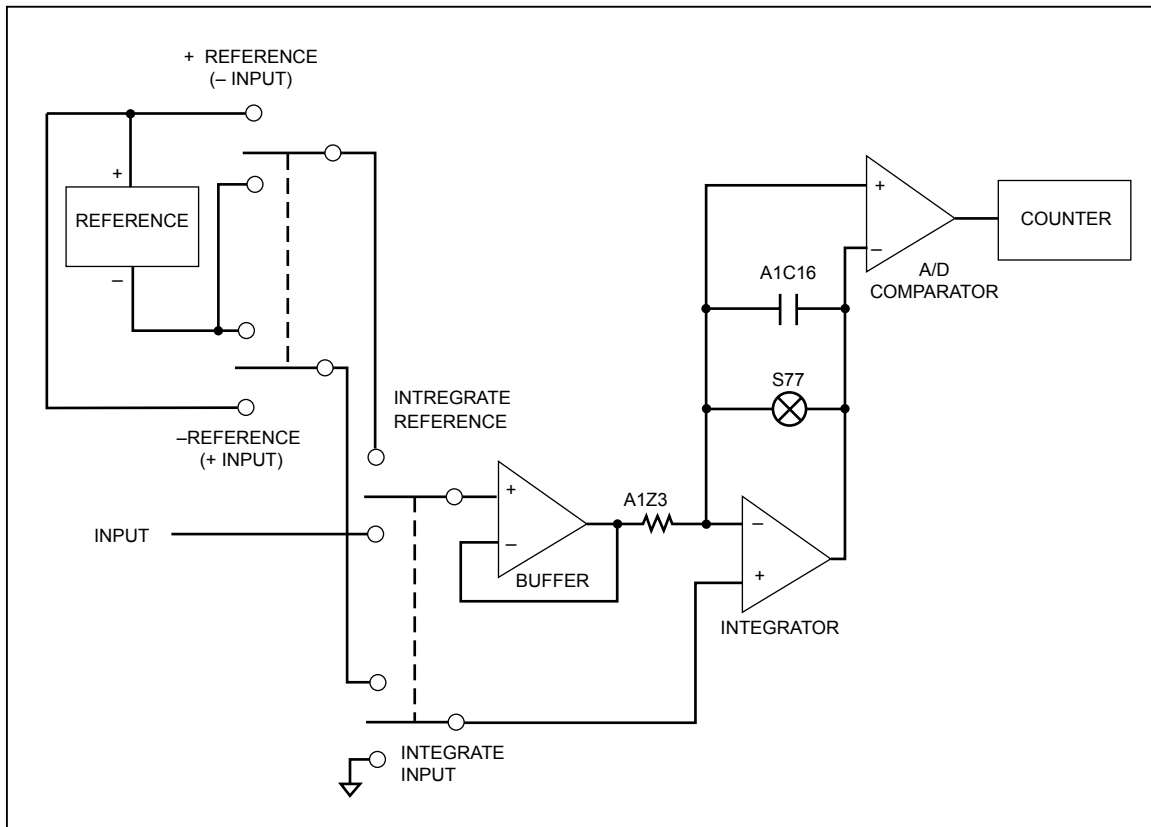

Figure 2-8. A/D Converter Simplified Schematic

qb08f.eps

2-33. Serial Communication (Guard Crossing)

The Microprocessor communicates with the Analog Measurement Processor using this isolated two-wire, full-duplex asynchronous interface circuit.

When the Microprocessor is transmitting to the Analog Measurement Processor, the transmit data bits appear at A1U6-11, which drives the combination of AQ19, A1R33 and A1U3-1. The optocoupler A1U3 then optically transfers this information to its output circuit, comprised of A1U3-7, A1R30, A1R28 and A1R27. The transmitted data is then presented to A1TP4 and A1U1-40.

When the Analog Measurement Processor is transmitting data back to the Microprocessor, the data bits appear at A1U1-39, which drives the input of a Darlington driver A1U2-1. The Darlington driver output then drives A1R29 and A1U4-1 to transfer the information to the output of the optocoupler at A1U4-7. Resistors A1R32 and A1R34 complete the optocoupler output circuit. Data is then routed to A1TP7 and A1U6-10 on the Microprocessor.

2-34. Digital Kernel

The Digital Kernel is composed of six functional circuit blocks: the RS-232 interface, the Microprocessor, the EEROM (Electrically Erasable Read Only Memory), the RAM (Random Access Memory), the ROM (Read Only Memory), and the IEEE-488 Option Connections. These blocks are described in the following paragraphs.

2-35. RS-232 Interface

The RS-232 interface is composed of connector A1J5, RS-232 level shifter A1U7 and the hardware serial communication interface (SCI) in Microprocessor A1U6.

The transmit signal from the SCI (A1U6-14) goes to the RS-232 driver (A1U7-12), where it is inverted and shifted to transition between approximately +5.0 and -5.0 V dc. When nothing is being transmitted by the meter, the driver output A1U7-5 is -5.0 V dc. The receive signal from A1J5 goes to the RS-232 receiver A1U7-4, where it is inverted and shifted to transition between +5.0 and 0 V dc. When nothing is being transmitted to the meter, the receiver output A1U7-13 is +5.0 V dc.

Data Terminal Ready (DTR) is a modem control signal controlled by the Microprocessor. This signal is an RS-232 output generated by driver A1U7-7; it is at +5.0 V dc when the meter is powered up.

2-36. Microprocessor

The Microprocessor utilizes an eight-bit data bus and a sixteen-bit address bus to access memory locations in ROM (A1U8), RAM (A1U10), and the IEEE-488 option. The upper three bits of the address bus are decoded by A1U9 to generate chip select signals for the ROM (A1U9-6) and RAM (A1U9-8). The Microprocessor enables the reading of memory by driving RD* (A1U6-67) low, and writing of memory by driving WR* (A1U6-66) low. The IEEE-488 option also makes use of the signal R/W* (read when high, write when low) that is generated by A1U6-65.

The Microprocessor operates with a memory cycle time of 1.085 us as determined by the 3.6864 MHz crystal A1Y2. The system clock signal (A1U6-68) is a square wave with a frequency of 921.6 kHz. It is used by the Display Assembly and the IEEE-488 option assembly after being damped by series resistor A1R57.

The Microprocessor uses synchronous communication to store and retrieve meter configuration and calibration information in the EEROM (A1U5). See the EEROM description for more detailed information.

The Microprocessor communicates to the Display Controller using a synchronous, three-wire communication interface described in detail in the Display Controller Theory of Operation.

The Microprocessor communicates to the Analog Measurement Processor (via the Serial Communication circuit) using an asynchronous communication protocol. Communication to the Analog Measurement Processor originates at A1U6-11 (which is normally low when no communication is being done). Communication from the Analog Measurement Processor to the Microprocessor appears at A1U6-10 and is normally low (unless communication is in progress.)

2-37. EEROM

The EEROM contains 64 registers, each of which is 16 bits long. These registers are used to provide non-volatile storage of meter configuration and calibration information. When the Microprocessor is communicating to the EEROM, Chip Select (A1U5-2) goes high to enable the EEROM interface.

When the Microprocessor is reading data from the EEROM, the data bits are serially shifted out on the Data Out signal (A1U5-6) with each one-to-zero transition of the Serial Clock (A1U5-3).

When the Microprocessor is writing commands and data to the EEROM, the bits are serially shifted into the EEROM on the Data In signal (A1U5-5) with each zero-to-one transition of the Serial Clock (A1U5-3). The EEROM drives the Data Out signal (A1U5-

6) low to indicate that it is busy writing the register, thereby controlling the timing of the write cycle. The microprocessor waits for this signal to go high before performing other EEROM operations. If the EEROM fails to drive this signal high, the microprocessor waits indefinitely.

New data is written to a register only after old data in that register is erased. After each such erase or write cycle, the microprocessor polls the status of EEROM by setting Chip Select (A1U5-2) high and checking the state of the Data Out signal (A1U5-6). If Data Out is low, the erase/write cycle is still in progress. If Data Out is high, the EEROM is ready for another command.

2-38. RAM

The RAM is a 8192 x 8 bit device that provides the temporary data storage used by the operating software of the meter. The chip select for this device (A1U10-20) goes low for any memory cycle between hexadecimal addresses 2000 and 3FFF. The RD* signal from the Microprocessor enables the reading of data when it is low, and the WR* signal writes data into the RAM when it is low.

2-39. ROM

The ROM provides the instruction storage for the Microprocessor. The chip select for this device (A1U8-20) goes low for any memory cycle between hexadecimal addresses 4000 and FFFF (accessing 48 kbytes.) Whenever this device is chip selected, the instruction in the addressed location is output to the data bus and read by the Microprocessor.

2-40. IEEE-488 Option Connections

The interconnection to the IEEE-488 option is implemented by two ribbon cables that mount to the 14-position and 20-position connectors on the Main PCA. The 14-position connector (A1J3) routes the 8-bit data bus, RD*, R/W*, E, RESET and OPTSW* signals to the option. The 20-position connector (A1J2) routes the 16-bit address bus and the WR* memory control signal to the option. This connector also routes the IEEE-488 interrupt and option sense signals from the option. See Chapter 8 for further information.

2-41. Display Assembly

Display Assembly operation classified into six functional circuit blocks: the Main Assembly Connector, the Front Panel Switches, the Display, the Beeper Drive Circuit, the Watchdog Timer/Reset Circuit, and the Display Controller. These blocks are described in the following paragraphs.

2-42. Main Assembly Connector

The Main Assembly Connector is a 20-pin connector (A2J1) that provides the interface between the Main Assembly and the other functional blocks on the Display Assembly. Seven of the connector pins provide the necessary connections to the four power supply voltages (-30 V dc, -5 V dc, +5 V dc, and 5 V ac). Six pins are used to provide the interface to the Front Panel Switches (A2SWR1 through A2SWR6). The other seven signals interface the Microprocessor to the Display Controller and pass the reset signals between the assemblies.

2-43. Front Panel Switches

The microprocessor scans the 19 Front Panel Switches (A2S1 through A2S18, and A2S21) using only six interface signals (plus the ground connection already available

from the power supply). These six signals (SWR1 through SWR6) are connected to a bi-directional I/O port on the microprocessor. Each successive column has one less switch.

This arrangement allows the unused interface signals to function as strobe signals when their respective column is driven by the microprocessor. The microprocessor cycles through six steps to scan the complete Front Panel Switch matrix. Table 2-5 shows the interface signal state and, if the signal state is an output, the switches that may be detected as closed.

In step 1, six port bits are set to input, and the interface signal values are read. In steps 2 through 6, the bit listed as output is set to output zero, the other bits are read, and bits indicated by a Z are ignored.

Each of the interface signals is pulled up to the +5 V dc supply by a 10 kΩ resistor in network A2Z1. Normally, the resistance between any two of the interface signals is approximately 20 kΩ. Checking resistances between any two signals (SWR1 through SWR6) verifies proper termination by resistor network A2Z1.

2-44. Display

The custom vacuum-fluorescent display (A2DS1) comprises a filament, 11 grids (numbered 0 through 10 from right to left on the display), and up to 14 anodes under each grid. The anodes make up the digits and annunciators for their respective area of the display. The grids are positioned between the filament and the anodes.

The filament is driven by a 5 V ac signal that is centered on a -25 V dc level. When a grid is driven to +5 V dc, the electrons from the filament are accelerated toward the anodes that are under that grid. Anodes under that grid that are also driven to +5 V dc are illuminated, but the anodes that are driven to -30 V dc are not. Grids are sequentially driven to +5 V dc, one at a time. The sequence is from GRID(0) to GRID(10), which is right to left as the display is viewed.

2-45. Beeper Drive Circuit

The Beeper Drive circuit is controlled by U1. A 3.6-kHz square wave appears at the PPO output of U1 and across the parallel combination of A2LS1 and A2R10, causing the beeper to resonate.

Table 2-5. Front Panel Switch Scanning

Step	Interface Signal States or Key Sensed					
	SWR6	SWR5	SWR4	SWR3	SWR2	SWR1
1	A2S8	A2S17	A2S10	A2S12	A2S18	A2S13
2	A2S1	A2S2	A2S3	A2S4	A2S11	0
3	A2S7	A2S9	A2S5	A2S6	0	Z
4	A2S14	A2S15	A2S16	0	Z	Z
5	n/a	n/a	0	Z	Z	Z
6	A2S21	0	Z	Z	Z	Z

A2Sn indicates switch closure sensed.
 0 indicates strobe driven to logic 0.
 Z indicates high impedance input; state ignored.

2-46. Watchdog Timer and Reset Circuit

This circuit provides active high and active low reset signals to the rest of the system at power-up or a system reset if the Microprocessor does not communicate with the Display Processor for a 5-second period. The Watchdog Timer and Reset Circuit is

comprised of dual retriggerable monostable multivibrator A2U5, NAND gates from A2U6, diode A2CR3, and various resistive and capacitive timing components.

At power-up, capacitor A2C3 begins to charge up through resistor A2R3. The voltage level on A2C3 is detected by an input of Schmitt-Trigger NAND gate A2U6-12. The output of this gate (A2U6-11) then drives the active high reset signal (RESET) to the rest of the system. When the voltage on A2C3 is below the input threshold of A2U6-12, A2U6-11 is high. As soon as A2C3 charges up to the threshold of A2U6-12, A2U6-11 goes low. The RESET signal drives NAND gate inputs A2U6-1 and A2U6-2, to generate the active low reset signal (RESET*) at A2U6-3.

When the RESET signal transitions from high to low (A2U5-1), the Watchdog Timer is triggered initially, causing A2U5-13 to go high. This half of the dual retriggerable monostable multivibrator uses timing components A2R2 and A2C2 to define a nominal 4.75-second watchdog timeout period. Each time a low-to-high transition of DISTX is detected on A2U5-2, capacitor A2C2 is discharged to restart the timeout period. If there are no low-to-high transitions on DISTX during the 4.75-second period, A2U5-13 transitions from high to low, triggers the other half of A2U5, and causes output A2U5-12 to go low. A2U5-12 is then inverted by A2U6 to drive the RESET signal high, causing a system reset. The low duration of A2U5-12 is determined by timing components A2Z1 and A2C4 and is nominally 460 μ s. When A2U5-12 goes high again, RESET goes low to retrigger the Watchdog Timer.

2-47. *Display Controller with FIP*

The Display Controller is a 4-bit, single-chip microcomputer with high-voltage outputs that drive a vacuum-fluorescent display directly. The controller receives commands over a three-wire communication channel from the Microprocessor on the Main Assembly. Each command is transferred serially to the Display Controller on the display transmit (DISTX) signal, with bits being clocked into the Display Controller on the rising edges of the display clock signal (DSCLK). Responses from the Display Controller are sent to the Microprocessor on the display receive signal (DISRX) and are clocked out of the Display Controller on the falling edge of DSCLK.

Figure 2-9 shows the waveforms during a single command byte transfer. Note that a high DISRX signal is used to hold off further transfers until the Display Controller has processed the previously received byte of the command.

Once reset, the Display Controller performs a series of self-tests, initializing display memory and holding the DISRX signal high. After DISRX goes low, the Display Controller is ready for communication; on the first command byte from the Microprocessor, the Display Controller responds with a self-test results response. If all self-tests pass, a response of 00000001 (binary) is returned. If any self-test fails, a response of 01010101 (binary) is returned. The Display Controller initializes its display memory to one of four display patterns depending on the states of the DTEST* (A2U1-41) and LTE* (A2U1-13) inputs. The DTEST* input is pulled up by A2Z1, but may be pulled down by jumpering A2TP4 to A2TP3 (GND). The LTE* input is pulled down by A2R12, but may be pulled up by jumpering A2TP5 to A2TP6 (VCC). The default conditions of DTEST* and LTE* cause the Display Controller to turn all segments on bright at power-up.

Table 2-6 defines the logic and the selection process for the four display initialization modes.

The two display test patterns are a mixture of on and off segments forming a recognizable pattern that allows for simple testing of display operation. The Display Controller provides 10 grid control outputs and 14 anode control outputs. Each of these 24 high-voltage outputs provides an active driver to the +5 V dc supply and a passive 70

kΩ (nominal) pull-down to the -30 V dc supply. These pull-downs are internal to the Display Controller.

The output port, P63, of the Display Controller, is used as a grid control output for GRID(10), of the vacuum-fluorescent display. A high voltage output, from P63, is provided with a 10 kΩ resistor (A2R1), and PNP transistor (A2Q1) provide an active driver to the +5 V dc supply and a passive 47 kΩ pull-down (A2R4) to -30 V dc.

The Display Controller drives the vacuum-fluorescent display in a multiplexed manner by strobing each grid individually while the segment data for that display area is presented on the anode outputs. Each grid is strobed for approximately 427 microseconds every 5.368 milliseconds, resulting in each grid on the display being strobed about 170 times per second. The grid strobing sequence is from GRID(0) to GRID(10), which results in right-to-left strobing of grid areas on the display. Figure 2-10 shows grid control signal timing.

The single grid strobing process involves turning off the previously enabled grid, outputting the anode data for the next grid, and then enabling the next grid. This procedure ensures that there is some time between grid strobes so that no shadowing occurs on the display. Figure 2-11 describes the timing relationship between an individual grid control signal and the anode control signals.

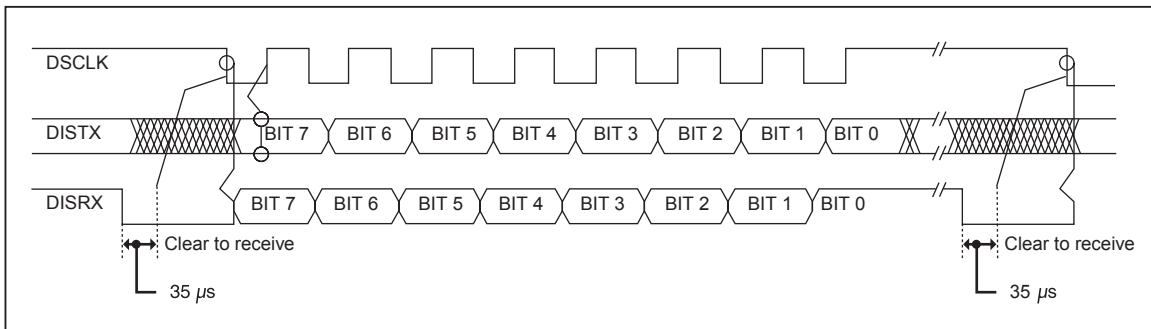

Figure 2-9. Command Byte Transfer Waveforms

qb09.eps

Table 2-6. Display Initialization Modes

A2TP4 Dtest*	A2TP5 LTE*	Power-Up Display Initialization
1	1	All Segments OFF
1	0	All Segments ON (default)
0	1	Display Test Pattern #1
0	0	Display Test Pattern #2

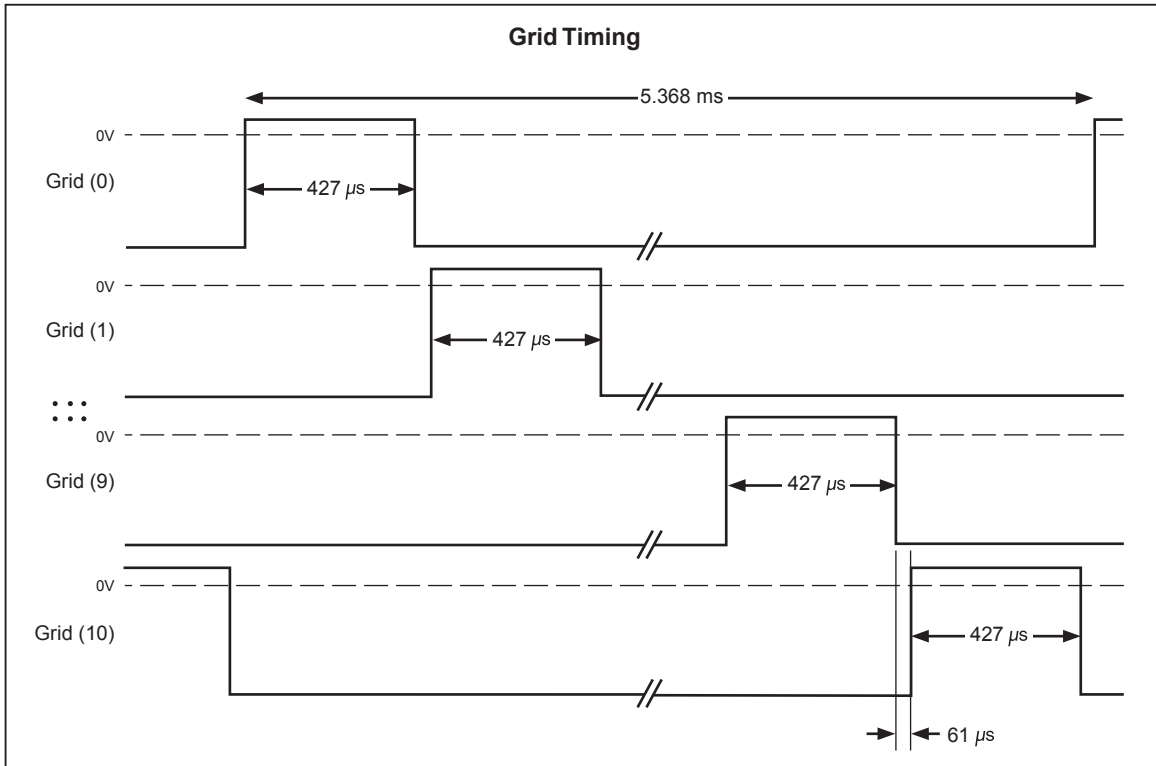

Figure 2-10. Grid Control Signal Timing

qb10f.eps

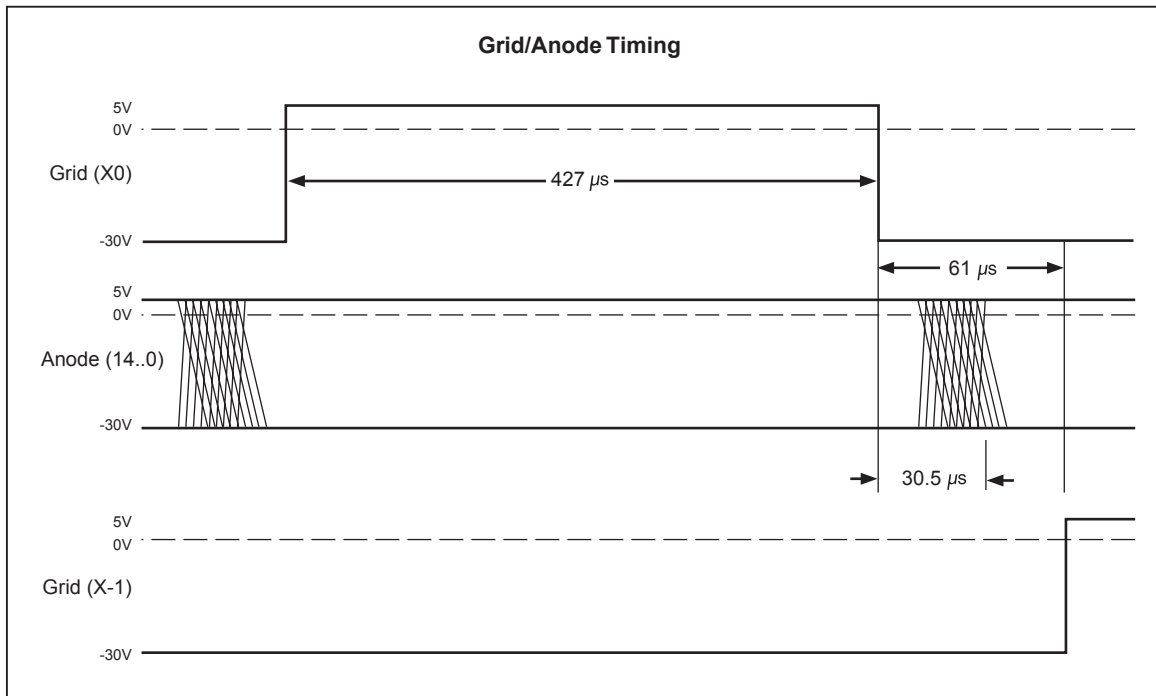

Figure 2-11. Grid-Anode Timing Relationships

qb11f.eps



static awareness



A Message From
Fluke Corporation

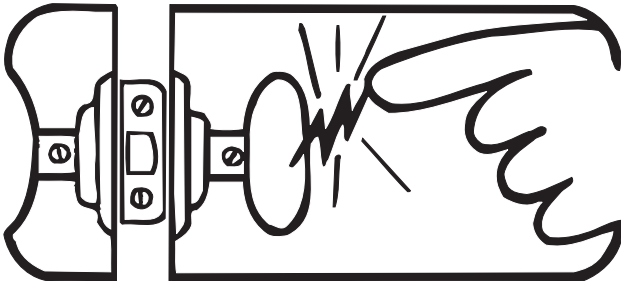

Some semiconductors and custom IC's can be damaged by electrostatic discharge during handling. This notice explains how you can minimize the chances of destroying such devices by:

1. Knowing that there is a problem.
2. Learning the guidelines for handling them.
3. Using the procedures, packaging, and bench techniques that are recommended.

The following practices should be followed to minimize damage to S.S. (static sensitive) devices.

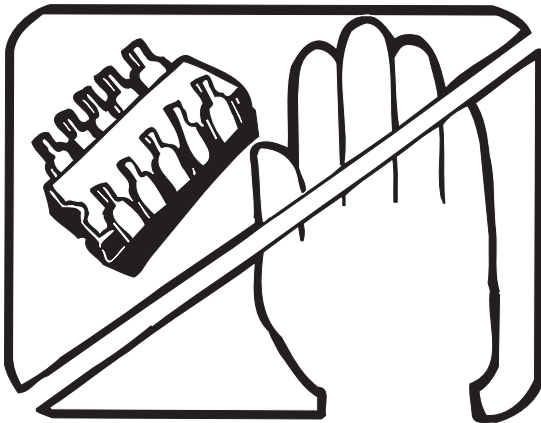

1. MINIMIZE HANDLING

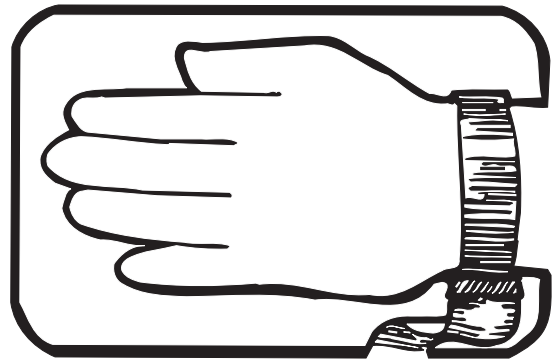

3. DISCHARGE PERSONAL STATIC BEFORE HANDLING DEVICES. USE A HIGH RESISTANCE GROUNDING WRIST STRAP.

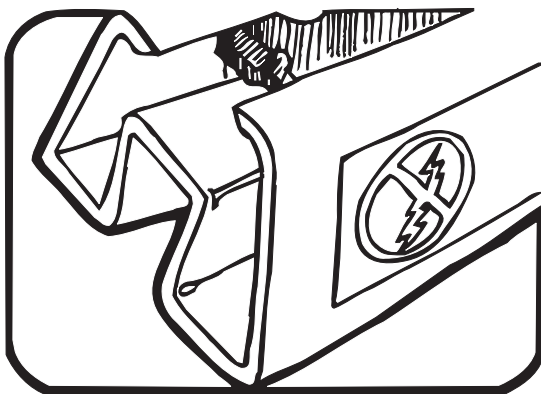

2. KEEP PARTS IN ORIGINAL CONTAINERS UNTIL READY FOR USE.

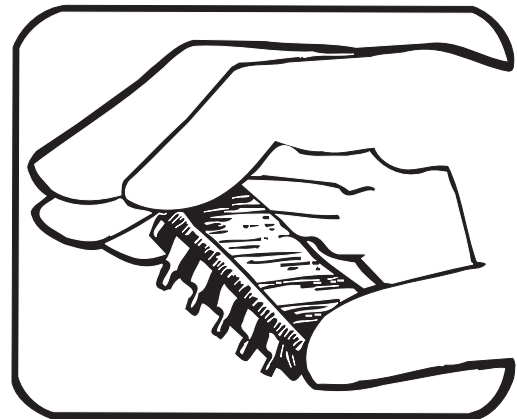

4. HANDLE S.S. DEVICES BY THE BODY.

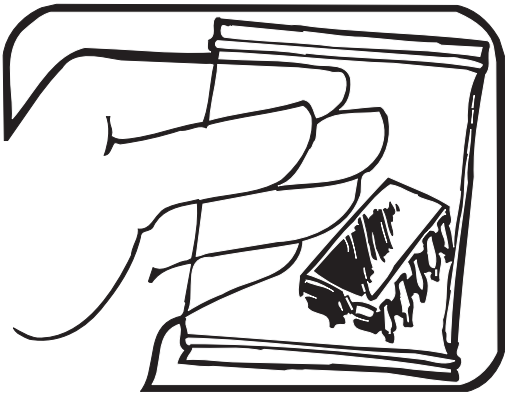

5. USE STATIC SHIELDING CONTAINERS FOR HANDLING AND TRANSPORT.

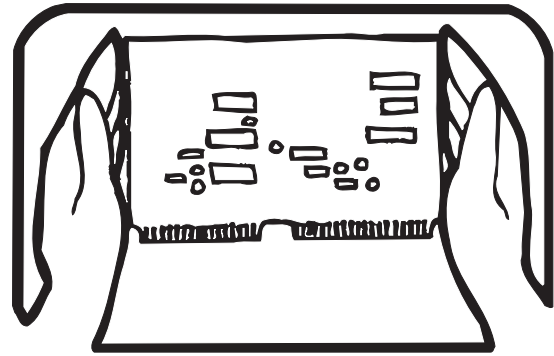

8. WHEN REMOVING PLUG-IN ASSEMBLIES HANDLE ONLY BY NON-CONDUCTIVE EDGES AND NEVER TOUCH OPEN EDGE CONNECTOR EXCEPT AT STATIC-FREE WORK STATION. PLACING SHORTING STRIPS ON EDGE CONNECTOR HELPS PROTECT INSTALLED S.S. DEVICES.

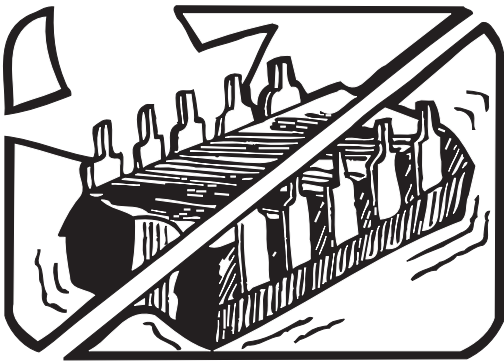

6. DO NOT SLIDE S.S. DEVICES OVER ANY SURFACE.

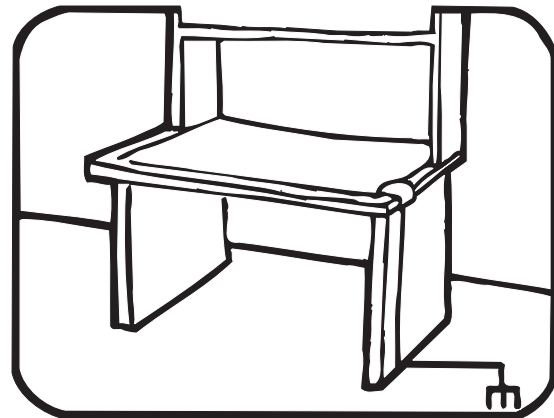

9. HANDLE S.S. DEVICES ONLY AT A STATIC-FREE WORK STATION.

10. ONLY ANTI-STATIC TYPE SOLDER-SUCKERS SHOULD BE USED.

11. ONLY GROUNDED-TIP SOLDERING IRONS SHOULD BE USED.

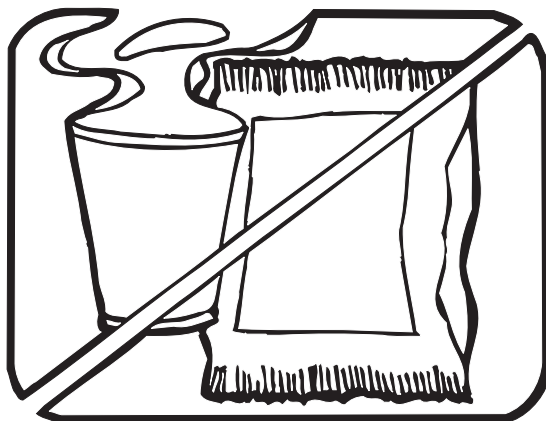

7. AVOID PLASTIC, VINYL AND STYROFOAM® IN WORK AREA.

PORTIONS REPRINTED
WITH PERMISSION FROM TEKTRONIX INC.
AND GERNER DYNAMICS, POMONA DIV.

Chapter 3

General Maintenance

	Title	Page
3-1.	Introduction.....	3-3
3-2.	Warranty Repairs and Shipping Information.....	3-3
3-3.	General Maintenance Information.....	3-3
3-4.	Required Equipment.....	3-3
3-5.	Power Requirements.....	3-3
3-6.	Static Safe Handling.....	3-3
3-7.	Cleaning.....	3-4
3-8.	Fuse Test and Replacement.....	3-4
3-9.	Line Fuse.....	3-4
3-10.	Current Input Fuses.....	3-4
3-11.	Testing Current Input Fuses.....	3-4
3-12.	Replacing the 500 mA and 440 mA Input Fuses (F1 and F5).....	3-5
3-13.	Replacing the 10 A Input Jack Fuse (F2).....	3-6
3-14.	Disassembly Procedures.....	3-7
3-15.	Remove the Meter Case.....	3-7
3-16.	Remove Handle and Mounting Brackets.....	3-7
3-17.	Remove the Front Panel Assembly.....	3-8
3-18.	Remove the Display PCA.....	3-8
3-19.	Remove the IEEE-488 Option.....	3-9
3-20.	Remove the Main PCA.....	3-9
3-21.	Remove the Analog Measurement Processor Shields.....	3-9
3-22.	Remove the Rms PCA.....	3-10
3-23.	Remove the Battery Option.....	3-10
3-24.	Disconnect Miscellaneous Chassis Components.....	3-10
3-25.	Assembly Procedures.....	3-10
3-26.	Install Miscellaneous Chassis Components.....	3-10
3-27.	Install the Battery Option.....	3-11
3-28.	Install the Rms PCA.....	3-11
3-29.	Install the Analog Measurement Processor Shields.....	3-11
3-30.	Install the Main PCA.....	3-11
3-31.	Install the IEEE-488 Option.....	3-12
3-32.	Assemble the Front Panel Assembly.....	3-12
3-33.	Install the Front Panel Assembly.....	3-15
3-34.	Install the Handle and Mounting Brackets.....	3-15
3-35.	Install the Meter Case.....	3-15

3-1. Introduction

This provides handling, cleaning, fuse replacement, disassembly, and assembly instructions.

3-2. Warranty Repairs and Shipping Information

If your meter is still under warranty, see the warranty information at the front of this manual for instructions on returning the unit. A list of Fluke telephone numbers and our website address can be found at the end of the warranty information and in Chapter 6.

3-3. General Maintenance Information

3-4. Required Equipment

Equipment required for calibration, troubleshooting, and repair of the Fluke 45 is listed in Table 4-4.

3-5. Power Requirements

⚠Warning

To avoid shock hazard, connect the meter power cord to a power receptacle with earth ground.

If you have not already done so, plug the line cord into the connector on the rear of the meter. The meter operates on any line voltage between 90 V ac and 264 V ac without adjustment, and at any frequency between 45 and 440 Hz. However, the meter is only warranted to meet published specifications at 50/60 Hz. The meter draws a maximum of 15 VA.

3-6. Static Safe Handling

All integrated circuits, including surface mounted ICs, are susceptible to damage from electrostatic discharge (ESD). Modern integrated circuit assemblies are more susceptible to damage from ESD than ever before. Integrated circuits today can be built with circuit lines less than one micron thick, allowing more than a million transistors on a 1/4-inch square chip. These submicron structures are sensitive to static voltages under 100 volts. This much voltage can be generated on a dry day by simply moving your arm. A person can develop a charge of 2,000 volts by walking across a vinyl tile floor, and polyester clothing can easily generate 5,000 to 15,000 volts during movement against the wearer. These low voltage static problems are often undetected because a static charge must be in the 30,000 to 40,000 volt range before a person will feel a shock.

Most electronic components manufactured today can be degraded or destroyed by ESD. While protection networks are used in CMOS devices, they can only reduce, not eliminate, component susceptibility to ESD.

ESD may not cause an immediate failure in a component; a delayed failure or "wounding" effect is caused when the semiconductor's insulation layers or junctions are punctured. The static problem is thus complicated in that failure may occur anywhere from two hours to six months after the initial damage.

Two failure modes are associated with ESD. First, a person who has acquired a static charge can touch a component or assembly and cause a transient discharge to pass through the device. The resulting current ruptures the junctions of a semiconductor. The second failure mode does not require contact with another object. Simply exposing a device to the electric field surrounding a charged object can destroy or degrade a component. MOS devices can fail when exposed to static fields as low as 30 volts.

Observe the following rules for handling static-sensitive devices:

1. Handle all static-sensitive components at a static-safe work area.
Use grounded static control table mats on all repair benches, and always wear a grounded wrist strap. Handle boards by their nonconductive edges only. Store plastic, vinyl, and Styrofoam objects outside the work area.
2. Store and transport all static-sensitive components and assemblies in static shielding bags or containers.

Static shielding bags and containers protect components and assemblies from direct static discharge and external static fields. Store components in their original packages until they are ready for use.

3-7. *Cleaning*

⚠ Warning

To avoid electrical shock or damage to the meter, never allow water inside the case. To avoid damaging the meter's housing, never apply solvents to the meter.

If the meter requires cleaning, wipe it down with a cloth that is lightly dampened with water or a mild detergent. Do not use aromatic hydrocarbons, chlorinated solvents, or methanol-based fluids when wiping the meter.

3-8. *Fuse Test and Replacement*

3-9. *Line Fuse*

The line fuse (a T 125 mA, 250 V, slow blow) is located on the rear panel. The fuse is in series with the power supply. For replacement, unplug the line cord and remove the fuse holder with fuse as shown in Figure 3-1. The meter is shipped with a replacement fuse.

3-10. *Current Input Fuses*

The 100 mA and 10 A inputs are protected by replaceable fuses.

- The 100 mA input is protected by 2 fuses, F1 and F5. F1 is rated at F 500 mA, 250 V (fast blow), 1500 A minimum breaking capacity, IEC-127 Sheet I and F5 is rated at 440 mA, 1000 V, 10,000 A minimum interrupt rating, (fast blow) fuse.
- The 10 A input is also protected by a fuse, F2, rated at F 11 A, 1000 V (fast blow), 17,000 A breaking capacity.

3-11. *Testing Current Input Fuses*

Perform the following procedure to test these fuses:

1. Plug a test lead into the **VΩ→** input terminal, and power up the meter.
2. Press **Ω** to select the ohms function.

3. Insert the test lead probe into the 100 mA input terminal. If the fuse is good, the meter will read between 11 and 15 Ω . If the fuse is blown, the meter will read $>10\text{ M}\Omega$ to OL.
4. Remove the test lead probe from the 100 mA input terminal, and insert it into the 10 A input terminal.

If the fuse is good, the meter will read between .04 and 1.0 Ω . If the fuse is blown, the meter will read $>10\text{ M}\Omega$ to OL.

3-12. Replacing the 500 mA and 440 mA Input Fuses (F1 and F5)

The 100 mA jack is protected by 2 fuses, F1 and F5. F1 is mounted in the front panel 100 mA input jack (Figure 3-2) and F5 is located inside the meter.

To replace F1, first unplug the line cord. Then press in on the input jack and turn it 90 degrees counterclockwise. Slide out the fuse holder and fuse.

Replace a blown fuse with one of identical rating (see Table 3-1), and reinsert the fuse and holder into the input terminal socket. Secure the fuse holder by pressing in and turning the holder 90 degrees clockwise.

To change the internal F5 fuse, see “Replacing the 10 A Input Fuse” later in this section.

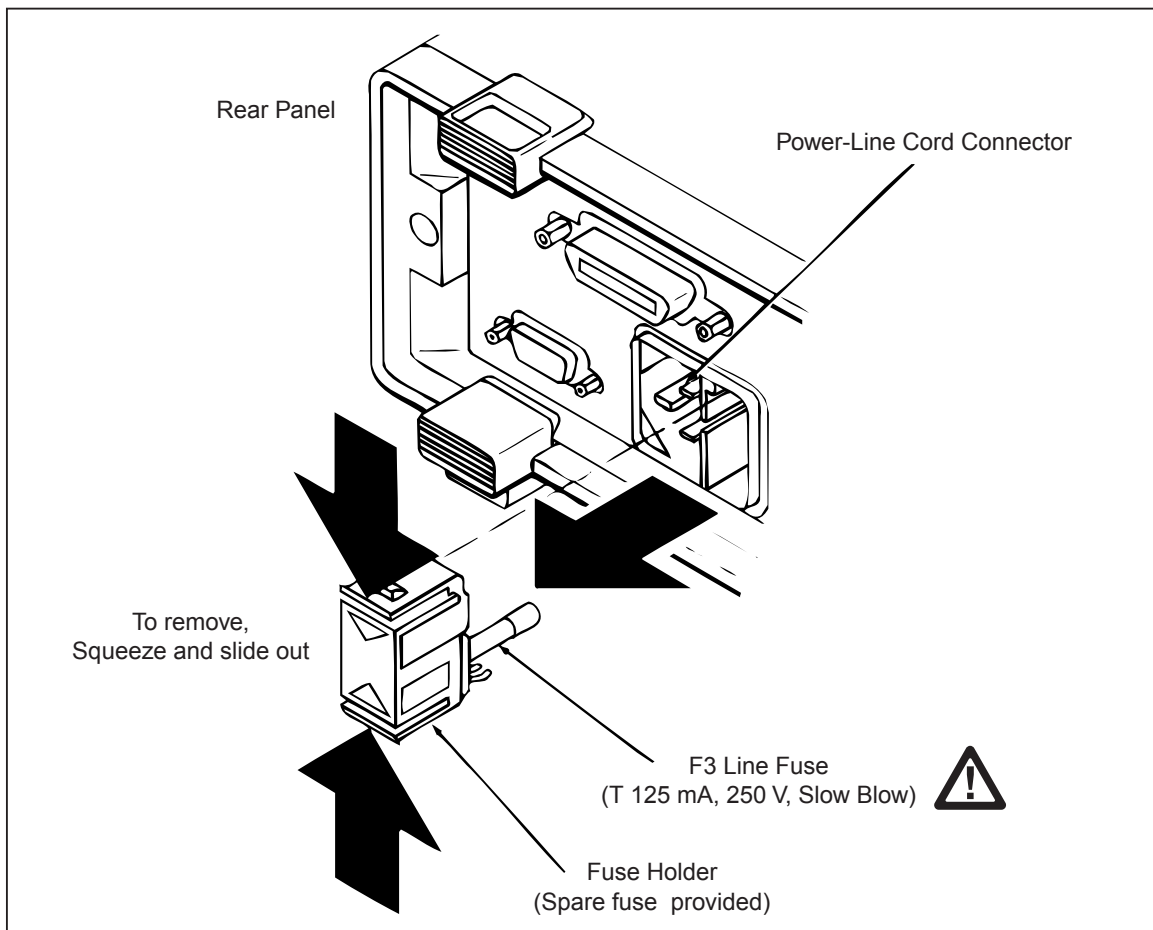

Figure 3-1. Replacing the Line Fuse (F3)

qb12f.eps

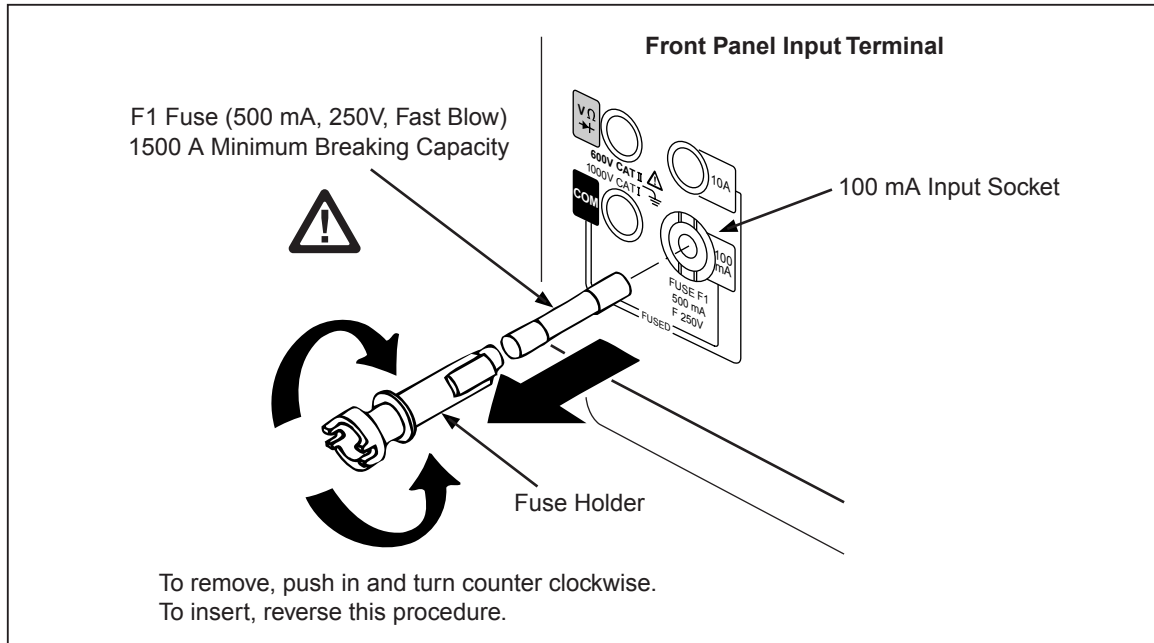

Figure 3-2. Replacing the External 100 mA Input Fuse (F1)

Table 3-1. Fuses

Item	Description	Fluke Part No.
⚠F1	100 mA Input Fuse. F 500 mA, 250 V, (fast blow), 1500 A breaking capacity.	838151
⚠F2	10 A Input Fuse. F 11 A, 1000 V, (fast blow), 17,000 breaking capacity.	943118
⚠F3	Line Fuse. T 125 mA, 250 V, (slow blow)	822254
⚠F5	100 mA Input Fuse. F440 mA, 1000 V, 10,000 A minimum interrupt.	943121

3-13. Replacing the 10 A Input Jack Fuse (F2)

The 10 A input jack is protected by an 11 A fuse (F2), located inside the meter. The following procedure explains how to access and change this fuse. This procedure can also be used to change F5.

1. Remove the single Phillips-head screw on the bottom of the case and the Phillips-head screw on each side of the rear bezel.

⚠ Warning

Opening the case may expose hazardous voltages. Always disconnect the power cord and measuring inputs before opening the case.

2. Remove the bezel and slip the case back from the front of the meter. The fuse and fuse clip are visible at the front of the main printed circuit assembly (pca) near the input terminals.
3. Carefully remove the fuse and install a properly-rated replacement.

3-14. Disassembly Procedures

The following paragraphs describe disassembly of the Fluke 45 in sequence (from the fully assembled meter to the chassis level.) Start and end your disassembly at the appropriate heading levels.

3-15. Remove the Meter Case

Use the following procedure to remove the meter case.

1. Make sure the meter is turned off and unplugged from the power outlet.
2. Discharge the power supply capacitor by turning on the meter (with the meter unplugged from the power line). After five seconds, turn the meter off.
3. Remove the screw from the bottom of the case, and remove the two screws from the rear bezel as shown in Figure 3-3 section A. While holding the front panel, slide the case and rear bezel off the chassis. (See Figure 3-3 section B.) (At this point, the rear bezel is not secured to the case.)

Caution

If the Main PCA is to be serviced and the Battery Option is installed, first unplug the battery ribbon cable from the Main PCA, or disconnect the wires to the battery. This measure prevents damage to the meter when you are servicing the Fluke 45 Main PCA.

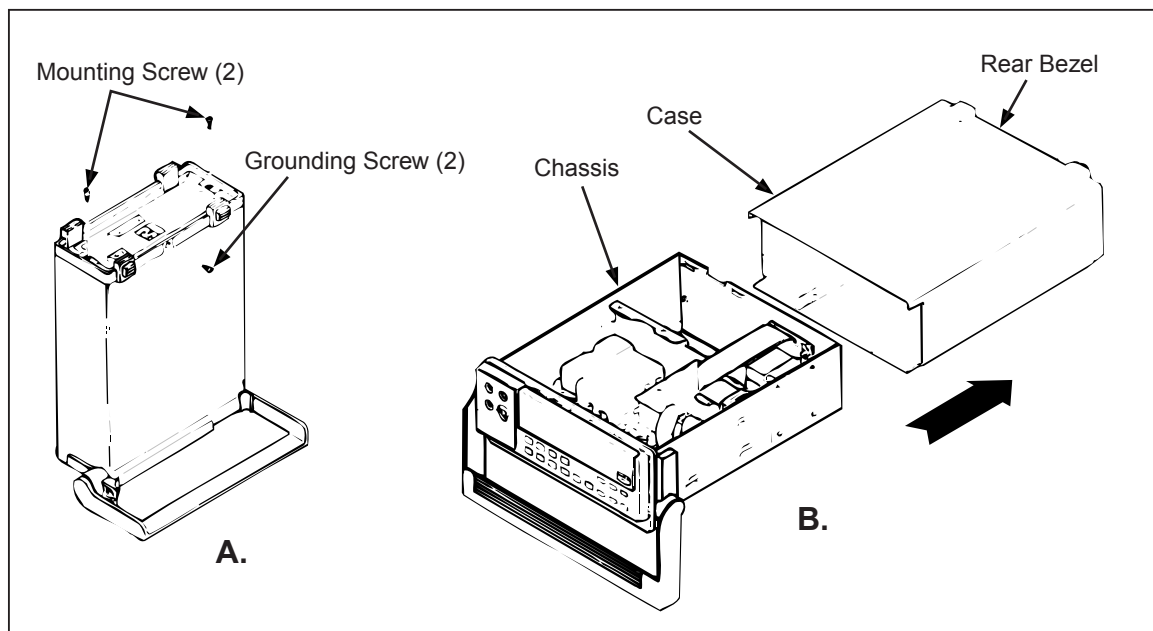

Figure 3-3. Removing the Case

qb14f.eps

3-16. Remove Handle and Mounting Brackets

Refer to Figure 3-4 during this procedure. Pull each handle pivot out slightly at the handle mounting brackets, then rotate the handle up over the display. With the handle pointing straight up, pull out and disengage one pivot at a time.

Use a Phillips head screwdriver to remove the two handle mounting brackets. Note that these brackets must be reinstalled in their original positions. Therefore, the inside of each bracket is labeled with an "R" or an "L", referenced to the front view of the meter.

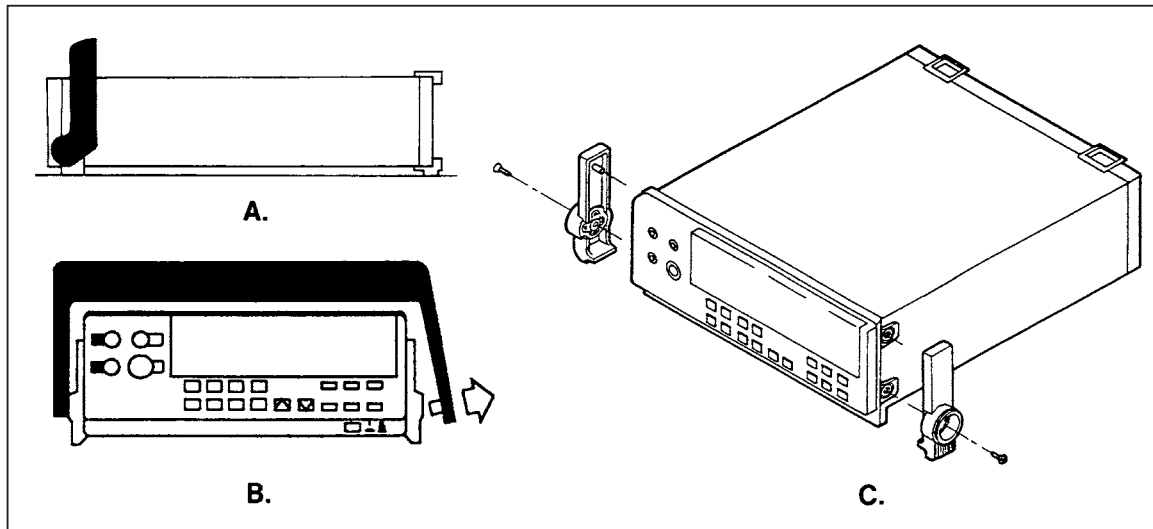

Figure 3-4. Removing the Handle and Handle Mounting Brackets

qb15c.eps

3-17. Remove the Front Panel Assembly

Remove all leads connected to the input terminals. Then remove the front panel 100 mA fuse. Using needle nose pliers, disconnect the wires at the rear of the $V\Omega \rightarrow +$, [COM], and [10 A] input terminals. At the rear of the [100 mA] terminal, carefully dislodge and withdraw the spring (attached to the white wire) from the fuse holder.

Locate the display ribbon cable connector on the Main PCA ("A" in Figure 3-5.) Using needle nose pliers, disconnect this cable by alternately pulling up on each end of its connector. Avoid breaking the alignment tabs on the Main PCA half of this connection.

Now remove the Front Panel Assembly by releasing the four snap retainers ("B" in Figure 3-5) securing it to the chassis.

3-18. Remove the Display PCA

The Display PCA is held in place with a set of tabs around its periphery. In sequence, release the tabs along the top, left side, and right side. Then slide the pca up and out, away from the bottom tabs.

Note

The Display PCA provides a space for a center securing screw. If the peripheral tabs are intact, this screw is not necessary. If some of the tabs are broken, the screw can be used as an additional securing device.

The elastomeric Keypad Assembly ("C" on Figure 3-5) can now be lifted away from the Front Panel Assembly.

Remove the display window ("D" on Figure 3-5) by releasing the two snaps along its inside, bottom edge. Use a gentle levering action between each snap and an adjacent edge on the Display Assembly.

Caution

Avoid using ammonia or methyl-alcohol cleaning agents on either the Front Panel of the display window. These types of cleaners can damage surface features and markings. Use an isopropyl-based cleaning agent or water to clean the Front Panel and the display window.

3-19. Remove the IEEE-488 Option

Chapter 8 of this manual provides a detailed removal procedure for the IEEE-488 option. The following removal instructions provide the essentials of this procedure. If necessary, refer to the complete procedure in Chapter 8, paying particular attention to Figures 8-2 and 8-3.

1. Use needle nose pliers to disconnect the 24-line cable assembly at the IEEE-488 PCA. Alternately pull on each end of the cable connector.
2. Remove the panhead Phillips screw at the rear of the IEEE-488 PCA.
3. Use needle nose pliers to detach the two ribbon cables at the front of the IEEE-488 PCA. Alternately pull on each end of the cable connector. Do not remove these cables at their Main PCA connections.

Note

The IEEE-488 ribbon cables are not interchangeable with the Display Assembly ribbon cable. Connectors on these cables are aligned differently, allowing for proper cable routing.

4. Remove the IEEE-488 PCA, disengaging the board from both the small slot in the side of the meter chassis and the plastic standoff at the front corner of the board.

3-20. Remove the Main PCA

With the IEEE-488 option and the Display Assembly removed, the Main PCA can be removed with the following procedure:

1. Remove the power switch activator rod ("E" in Figure 3-5) from the bottom of the Main PCA.
2. Detach the transformer connector (right rear corner of the Main PCA, "F" in Figure 3-5) and the RS-232 connector (center of the Main PCA, "G" in Figure 3-5.) If the Battery Option is installed, detach its connector at the center-rear of the Main PCA.
3. Now remove the securing screw (near the battery connector, "H" in Figure 3-5), and slide the Main PCA forward. Match the pca edge indentations to the guide tabs on each chassis side, then lift the Main PCA up and away from the chassis.

To remove the transformer insulator (center rear of the Main PCA, "I" in Figure 3-5), detach the two tabs and pull up.

3-21. Remove the Analog Measurement Processor Shields

The Analog Measurement Processor resides within a plastic shield on the top of the Main PCA. Although having the appearance of a dark gray piece of plastic, this shield is electrically conductive; treat it as you would any other conducting surface. On the bottom of the Main PCA, the Analog Measurement Processor is protected with a metallic shield. Access the Analog Measurement Processor with the following procedure:

- Working from the bottom of the Main PCA, remove the single Phillips head screw ("J" in Figure 3-6) securing the metallic shield, then lift the plastic shield ("M") away from the top of the Main PCA.
- If necessary, remove the metallic shield ("K".) Avoid contacting any circuit traces during this procedure. First rotate the shield toward the pca edge, then pry the shield free from its nylon standoff ("L").

3-22. Remove the Rms PCA

The rms pca is soldered in place on the Main PCA (within the Analog Measurement Processor shield.) For access procedures, refer to "Remove the Analog Measurement Processor Shields". Use standard desoldering techniques (e.g. solder sucker or solder wick) when removing this assembly.

3-23. Remove the Battery Option

Use the following procedure to remove the Battery Option. Refer to Figures 7-2 and 7-3 (Chapter 7) to identify features and techniques mentioned here. If necessary, refer to Chapter 7 for a detailed description of Battery Option removal.

1. Disconnect the flat white battery option connecting cable at the Battery Option PCA.
2. Remove the two #6-32 x 1/4" panhead Phillips screws securing the Battery Option.
3. Carefully slide the Battery Option out of the meter. Do not pinch the wires running from the pca to the battery terminals.

3-24. Disconnect Miscellaneous Chassis Components

The following procedures can be used to disconnect remaining hardware from the chassis:

1. Use needle nose pliers to remove the internal connections at the line power plug.
2. Remove the power plug by releasing its two snaps, one at a time.
3. Disconnect the power transformer by removing the four screws ("N" in Figure 3-5) that secure it to the right side of the chassis.
4. Remove the RS-232 connector ("O") on the rear of the chassis. Use a 3/16-inch nut driver to loosen the connector securing hardware. Also, disconnect the ground wire at its chassis connection.
5. Remove the IEEE connector.

3-25. Assembly Procedures

Generally, assembly procedures follow a reverse sequence of disassembly procedures. As some differences do apply, assembly is described separately in the following paragraphs. Begin assembly at the appropriate level, as defined by the heading. References are made to items in Figure 3-5 for assembly details of standard meter parts.

3-26. Install Miscellaneous Chassis Components

Use the following procedure to replace any items that have been removed from the basic chassis.

1. Install the IEEE connector on the rear of the chassis.

2. Replace the RS-232 connector ("O") on the rear of the chassis. Use a 3/16-inch nut driver to tighten the connector hardware. Also, attach the ground wire at its chassis connection.
3. Replace the power transformer along the right side of the chassis. Use four 6-32 x .25 FHU screws ("N"), inserted from the exterior of the meter.
4. Snap the power plug into position.
5. Use needle nose pliers to replace the interior connections at the power plug.

3-27. Install the Battery Option

Installation is fully described in both the instruction sheet supplied with the Battery Option and in Chapter 7 of this manual. The following procedure presents installation essentials. Figures 7-2 and 7-3 can be used in identifying features and techniques mentioned here.

1. Carefully slide the battery kit into the area reserved for it in the back of the meter. Make sure that both the retaining slots line up and the mounting holes mate. Do not pinch wires running from the circuit assembly to the battery terminals.
2. Secure the battery kit with two #6-32 x 1/4" panhead Phillips screws.
3. Attach the flat, white connecting cable at the Battery Option PCA. The single blue marking line of the cable should be to the rear of the meter. Align the plastic socket on the cable end, then seat it securely in place.

3-28. Install the Rms PCA

With the Analog Measurement Processor shields removed, solder the Rms PCA into place on the upper side of the Main PCA. The component side of the Rms PCA faces forward.

3-29. Install the Analog Measurement Processor Shields

The Analog Measurement Processor resides within a plastic shield on the top of the Main PCA. Although having the appearance of a dark gray piece of plastic, this shield is electrically conductive; treat it as you would any other conducting surface. On the bottom of the Main PCA, the Analog Measurement Processor is protected with a metallic shield.

Press the conductive plastic shield ("M") into place on the top of the Main PCA. From the bottom of the Main PCA, install the metallic shield ("K".) Avoid contacting any circuit traces during this procedure. Then replace the single Phillips head screw ("J") securing the metallic shield.

3-30. Install the Main PCA

1. Prior to installing the Main PCA, verify the following:
 - If necessary, reinstall the transformer insulator ("I"), tabs down, around the right side of the transformer. Once the insulator is in place, pull each tab through the Main PCA from bottom side with a needle nose pliers.
 - If the nylon standoff ("L") used between the Main PCA and the metallic shield surrounding the Analog Measurement Processor has been removed, verify that proper orientation is maintained during installation. The standoff end with the shorter, beveled indent fits into the metallic shield. Press the standoff end with the wider, straighter indent into the Main PCA with a 3/16 nut driver.

2. Ensure that the nylon standoff support (front-center of the Main PCA) is in place. Then slide the Main PCA onto the chassis slider taps.
3. Fasten the Main PCA to the chassis with a 6-32, 1/4-inch panhead screw ("H").
4. Connect the transformer cable ("F") and RS-232 cable ("G") at the Main PCA.

3-31. Install the IEEE-488 Option

Both the instruction sheet provided with the IEEE-488 Option and Chapter 8 of this manual fully describe installation. The following instructions provide installation procedure essentials. If necessary, refer to Chapter 8, paying particular attention to Figures 8-2 and 8-3.

1. Check that the plastic standoff remains in the appropriate hole in the Main PCA (narrow end of the standoff down.)
2. If necessary, install the two ribbon cables on the IEEE-488 circuit board. Each cable fits in only one socket and in only one direction. Make sure the cables lock firmly in place.
3. Attach opposite ends of the ribbon cables onto the Fluke 45 Main PCA.
4. Install the IEEE-488 PCA into the small slot in the side of the Fluke 45 (two ribbon cables facing forward.) The end of the plastic standoff fits into the hole in the IEEE-488 PCA. Make sure the IEEE-488 PCA is firmly gripped against the retainer on the standoff and that the rear of the pca rests upon the support just forward of the transformer.
5. Secure the rear of the IEEE-488 PCA with the panhead Phillips screw.
6. Connect the 24-line cable assembly to the IEEE-488 circuit board.

3-32. Assemble the Front Panel Assembly

As appropriate, use the following steps to assemble the Front Panel Assembly.

1. Clean the lens ("D") with deionized air and, if necessary, isopropyl alcohol. Then gently snap the lens into the front panel tabs.
2. Install the elastomeric keypad assembly ("C"). Make sure that the four front panel guide pins protrude through the keypad.
3. On the Display PCA, clean the display with deionized air and, if necessary, isopropyl alcohol.
4. Slide the Display PCA into the bottom securing tabs on the back of the Front Panel Assembly. Then gently snap the pca into the remaining tabs along its periphery.

Note

The Display PCA provides a space for a center securing screw. If the peripheral tabs are intact, this screw is not necessary. If some of the tabs are broken, the screw can be used as an additional securing device.

5. Connect the 20-pin cable connector ("A") to the Display PCA.

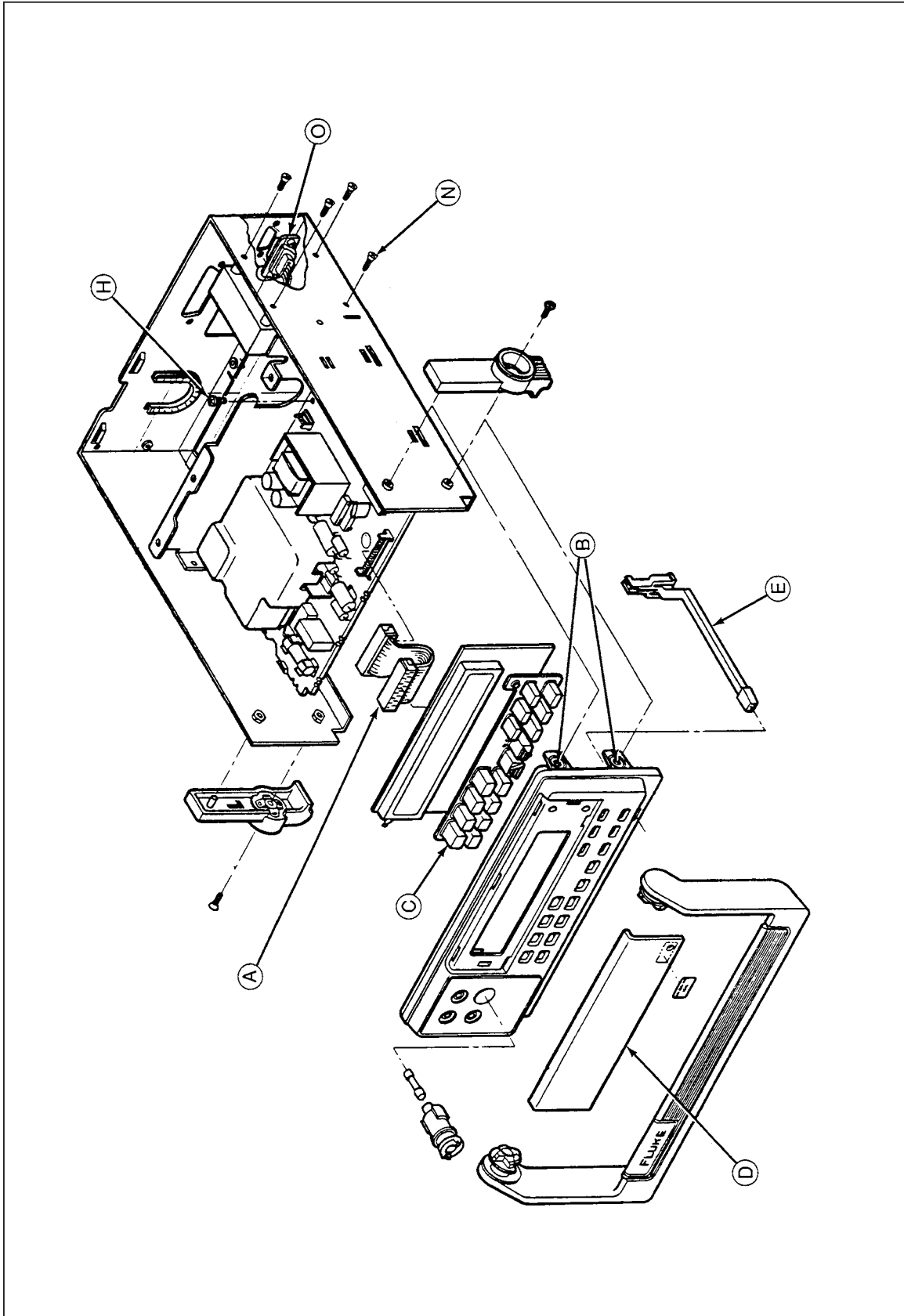

Figure 3-5. Assembly Details

qb16c.eps

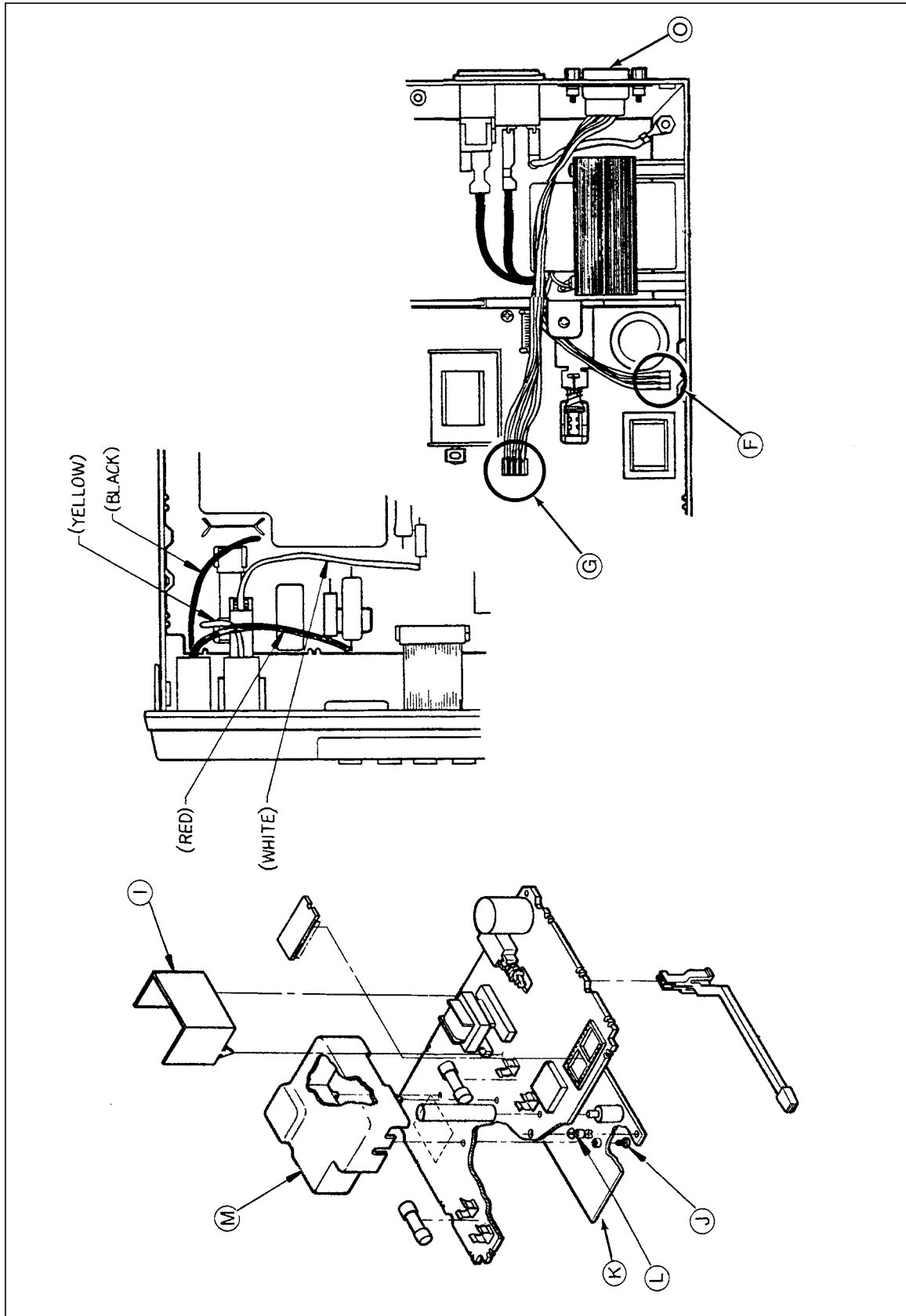

Figure 3-5. Assembly Details (cont)

qb17c.eps

3-33. Install the Front Panel Assembly

Use the following procedure when installing the Front Panel Assembly:

1. Snap the Front Panel Assembly into place in the four tab retainers ("B").
2. Observing the alignment orientation provided by tabs on the connector, attach the display ribbon cable connector ("A") on the Main PCA.
3. Attach the wires at the rear of the front panel input terminals. Observe the following color coding:
 - At the rear of the 100 mA input terminal, carefully insert the spring (attached to the white wire) into the fuse holder.
 - Using needle nose pliers, connect the wires at the rear of the input terminals as follows:

VΩ→ Red
[COM] Black
[10 A] Yellow

- Install the front panel 100 mA input fuse (F1).

3-34. Install the Handle and Mounting Brackets

Refer to Figure 3-4 during the following procedure. Use a Phillips head screwdriver to attach the two handle mounting brackets. Note that these brackets must be reinstalled in their original positions. Therefore, the inside of each bracket is labeled with an "R" or an "L", in reference to the front view of the meter.

Now, engage the handle. Point the handle straight up. Then pull out on each end of the handle to engage the respective pivot in its bracket. Pull out slightly on both pivots to rotate the handle to the desired position.

3-35. Install the Meter Case

Reinstall the meter case, checking that it seats properly in the front panel. Attach the rear bezel with the two panhead Phillips screws and secure the case with the flathead Phillips screw in the bottom. Refer to Figure 3-3.

Chapter 4

Performance Testing and Calibration

	Title	Page
4-1.	Introduction.....	4-3
4-2.	Required Equipment	4-3
4-3.	Performance Tests	4-4
4-4.	Front Panel Calibration.....	4-7
4-5.	Introduction	4-7
4-6.	Entering Calibration Mode.....	4-8
4-7.	Exiting Calibration Mode.....	4-9
4-8.	DC Volts Calibration (Front Panel)	4-9
4-9.	AC Volts Calibration (Front Panel)	4-9
4-10.	DC and AC Milliamp Calibration (Front Panel).....	4-9
4-11.	DC and AC Amps Calibration (Front Panel)	4-11
4-12.	Ohms Calibration (Front Panel)	4-11
4-13.	Alternate Ohms Calibration (Front Panel)	4-13
4-14.	Continuity/Hysteresis Threshold Calibration (Front Panel)	4-13
4-15.	Frequency Calibration (Front Panel).....	4-13
4-16.	C2 Adjustment Procedure	4-13
4-17.	Editing the Prompt for Different Calibration Points	4-14
4-18.	Calibration Using the Computer Interface.....	4-15
4-19.	Setup.....	4-15
4-20.	RS-232 Interface	4-15
4-21.	IEEE-488 Interface.....	4-16
4-22.	The Calibration Procedure	4-18
4-23.	DC Volts Calibration (Computer Interface).....	4-19
4-24.	AC Volts Calibration (Computer Interface).....	4-19
4-25.	DC and AC Milliamps Calibration (Computer Interface).....	4-19
4-26.	DC and AC Amps Calibration (Computer Interface).....	4-19
4-27.	Ohms Calibration (Computer Interface).....	4-19
4-28.	Continuity/Hysteresis Threshold Calibration (Computer Interface)	4-20
4-29.	Frequency Calibration (Computer Interface)	4-20
4-30.	Concluding Calibration Using the Computer Interface.....	4-20
4-31.	Alternate Ohms Calibration (Computer Interface).....	4-20

4-1. Introduction

This chapter of the Service Manual provides performance tests that can be used at any time to verify Fluke 45 operation within published specifications. A complete calibration procedure is also included. The performance test and, if necessary, the calibration procedure can be performed periodically and after service or repair.

4-2. Required Equipment

Equipment required for performance testing and calibration is listed in Table 4-1.

Table 4-1. Recommended Test Equipment

Instrument Type	Minimum Specifications	Recommended Model									
Multifunction Calibrator	DC Voltage: Range = 90 mV to 1000 V dc Accuracy = .005%	Fluke 5700A with wideband option									
	AC Voltage: <table style="width: 100%; border-collapse: collapse;"> <tr> <td style="text-align: center;">Frequency</td> <td style="text-align: center;">Voltage</td> <td style="text-align: center;">Accuracy</td> </tr> <tr> <td style="text-align: center;">1 kHz</td> <td style="text-align: center;">29 mV to 750 V</td> <td style="text-align: center;">0.05%</td> </tr> <tr> <td style="text-align: center;">100 kHz</td> <td style="text-align: center;">15 mV to 300 mV</td> <td style="text-align: center;">1.25%</td> </tr> </table>		Frequency	Voltage	Accuracy	1 kHz	29 mV to 750 V	0.05%	100 kHz	15 mV to 300 mV	1.25%
	Frequency		Voltage	Accuracy							
	1 kHz		29 mV to 750 V	0.05%							
100 kHz	15 mV to 300 mV	1.25%									
AC Milliamps: <table style="width: 100%; border-collapse: collapse;"> <tr> <td style="text-align: center;">Frequency</td> <td style="text-align: center;">Current</td> <td style="text-align: center;">Accuracy</td> </tr> <tr> <td style="text-align: center;">1 kHz</td> <td style="text-align: center;">29 mA to 100 mA</td> <td style="text-align: center;">0.125%</td> </tr> </table>	Frequency	Current	Accuracy	1 kHz	29 mA to 100 mA	0.125%					
Frequency	Current	Accuracy									
1 kHz	29 mA to 100 mA	0.125%									
DC Milliamps: <table style="width: 100%; border-collapse: collapse;"> <tr> <td style="text-align: center;">Frequency</td> <td style="text-align: center;">Voltage</td> <td style="text-align: center;">Accuracy</td> </tr> <tr> <td style="text-align: center;">10 kHz</td> <td style="text-align: center;">1 V</td> <td style="text-align: center;">0.125%</td> </tr> </table>	Frequency	Voltage	Accuracy	10 kHz	1 V	0.125%					
Frequency	Voltage	Accuracy									
10 kHz	1 V	0.125%									
Boost Amplifier	DC Amps: <table style="width: 100%; border-collapse: collapse;"> <tr> <td style="text-align: center;">Current</td> <td style="text-align: center;">Accuracy</td> </tr> <tr> <td style="text-align: center;">10 A</td> <td style="text-align: center;">.05%</td> </tr> </table>	Current	Accuracy	10 A	.05%	Fluke 5725A					
	Current	Accuracy									
10 A	.05%										
AC Amps: <table style="width: 100%; border-collapse: collapse;"> <tr> <td style="text-align: center;">Frequency</td> <td style="text-align: center;">Current</td> <td style="text-align: center;">Accuracy</td> </tr> <tr> <td style="text-align: center;">1 kHz</td> <td style="text-align: center;">2A and 10 A</td> <td style="text-align: center;">0.25%</td> </tr> </table>	Frequency	Current	Accuracy	1 kHz	2A and 10 A	0.25%					
Frequency	Current	Accuracy									
1 kHz	2A and 10 A	0.25%									
Decade Resistance Source	Ohms	Accuracy	General Resistance Inc. Model RDS 66A								
	290 Ω	0.0125%									
	2.9 kΩ	0.0125%									
	29 kΩ	0.0125%									
	290 kΩ	0.0125%									
	2.9 MΩ	0.0125%									
<p><i>Note</i></p> <p><i>The 5700A Calibrator can be used for 0.05% accuracy (rated) on the 3.0 kΩ, 30 kΩ, 300 kΩ, and 3.0 MΩ ranges. This calibrator can be used for 0.06% accuracy on the 100 Ω and 300 Ω ranges.</i></p>											

4-3. Performance Tests

The following performance tests are provided to ensure that the meter is in proper operating condition. If the meter fails any of the performance tests, calibration adjustment and/or repair is needed. To perform these tests, you will need a Fluke 5700A Multifunction Calibrator and a 5725A Amplifier or equipment meeting the minimum specifications given in Table 4-1.

Each of the measurements listed in the following steps assumes the meter is being tested after a one-hour warmup in an environment with an ambient temperature of 18 to 28°C and a relative humidity of less than 90% (70% for MΩ ranges). The limits in Table 4-2 represent the 1-year calibration cycle.

Note

All measurements listed in the performance test tables are made in the medium reading rate unless otherwise noted.

1. Power up the meter and allow it to stabilize for one hour.
2. Connect a cable from the Output VA HI and LO connectors of the 5700A to the **VΩ→+** and COM connectors on the Fluke 45. Select the function and range on the Fluke 45 and the input level from the 5700A using the values listed in Table 4-2. The display should read between the minimum and maximum values listed in the table.
3. Connect a cable from the Output VA HI and LO connectors of the 5700A to the [100 mA] and COM connectors on the Fluke 45. Select the function and range on the Fluke 45 and the input level from the 5700A using the values contained in Table 4-3. The display should read between the minimum and maximum readings listed in the table.
4. The following tests require a Fluke 5725A Amplifier (or equivalent) to be used with the 5700A. The input level for the performance test will be set on the 5700A but will be output from the 5725A Amplifier.

Connect a cable from the Output VA HI and LO connectors of the 5725A to the [10 A] and COM connectors on the Fluke 45. Select the function and range on the Fluke 45 and the input level from the 5700A using the values contained in Table 4-4. The display should read between the minimum and maximum readings listed in the table.

Table 4-2. Performance Tests for Volts, Diode Test, Ohms, and Frequency Functions





Function	Range (Rate)***	Input Level	Frequency	Display	
				Min	Max
	100 mV (slow)	short	-	-0.006	0.006
		90 mV	-	89.971	90.029
	1000 mV (slow)	900 mV	-	899.71	900.29
		300 mV	short	-	-0.02
	3 V	300 mV	-	299.90	300.10
		-3 V	-	-3.0010	-2.9990
	30 V	-30 V	-	-30.010	-29.990
	300 V	-300 V	-	-300.10	-299.90
	1000 V	-1000 V	-	-1000.5	-999.5
	30 V	30 V	-	29.990	30.010
	300 V	300 V	-	299.90	300.10
	1000 V	1000 V	-	999.5	1000.5
	-	short	-	-0.0008 (tone)	0.0008 (tone)
	-	open	-	OL	OL
	300 mV	short	-	-	<0.75
		15 mV	1 kHz	14.87	15.13
		300 mV	100 kHz	13.75	16.25
			1 kHz	299.30	300.70
	3 V	300 mV	100 kHz	284.50	315.50
		3.0 V	1 kHz	2.9930	3.0070
	30 V	30 V	1 kHz	29.930	30.070
	300 V	300 V	1 kHz	299.30	300.70
750 V	750 V	1 kHz	747.5	752.5	
	Using decades of 3:				
	300 Ω*	short		0.00	0.04
		300 Ω		299.83	300.19
	3 kΩ*	short		0.000	0.0002
		3 kΩ		2.9983	3.0017
	30 kΩ	30 kΩ		29.983	30.017
	300 kΩ	300 kΩ		299.83	300.17
	3 MΩ	3 MΩ		2.9980	3.0020
	30 MΩ**	30 MΩ		29.922	30.078
	300 MΩ	300 MΩ		294.0	306.0
	Using decades of 1.9:				
	300 Ω*	short		0.00	0.04
		190 Ω		189.88	190.14

Table 4-2. Performance Tests for Volts, Diode Test, Ohms, and Frequency Functions (cont)

Function	Range (Rate)***	Input Level	Frequency	Display	
				Min	Max
Ω	3k Ω^*	short		0.0000	0.0002
		1.9 k Ω		1.8988	1.9012
		30 k Ω		18.988	19.012
		300 k Ω		189.88	190.12
		3 M Ω		1.8987	1.9013
		30 M Ω^{**}		18.949	19.051
	300 M Ω^{**}	190 M Ω		186.2	193.8
		Using decades of 1.0:			
	300 Ω^*	short		0.00	0.04
		100 Ω		99.93	100.09
	3 k Ω	short		0.0000	0.0002
		1 k Ω		0.9993	1.0007
	30 k Ω	10 k Ω		9.993	10.007
	300 k Ω	100 k Ω		99.93	100.07
	3 M Ω	1 M Ω		0.9992	1.0008
	30 M Ω^{**}	10 M Ω		9.972	10.028
	300 M Ω^{**}	100 M Ω		98.0	102.0
FREQ	10/100 kHz	0.1 to 10 V	10 kHz	9.994	10.006
<p>* Use either 2-wire compensation on the 5700A or the relative (REL) mode on the 45. ** Optional test points that can be used if standards are available. *** All measurement rates are in medium speed unless otherwise specified.</p>					

Table 4-3. Performance Tests for mA Current Functions

Function	Range (Rate)	Input Level	Frequency	Display	
				Min	Max
A $\overline{\text{---}}$ (mA)	30 mA	+30 mA	-	29.982	30.018
	100 mA	+100 mA	-	99.93	100.07
A \sim (mA)	30 mA	30 mA	1 kHz	29.840	30.160
	100 mA	100 mA	1 kHz	99.40	100.60

Table 4-4. Performance Tests for Current Functions

Function	Range (Rate)	Input Level	Frequency	Display	
				Min	Max
A $\overline{\text{---}}$	10 A	+10 A	-	9.975	10.025
A \sim	10 A	10 A	1 kHz	9.890	10.110

4-4. Front Panel Calibration

The Fluke 45 features closed-case calibration using known reference sources. The multimeter automatically prompts you for the required reference sources, measures them, calculates correction factors, and stores the correction factors in the nonvolatile calibration memory.

Closed-case calibration has many advantages. There are no parts to disassemble, no mechanical adjustments to make, and the Fluke 45 can be calibrated by an automated instrumentation system.

The Fluke 45 should normally be calibrated on a regular cycle, typically every 180 days or 1 year. The chosen calibration cycle depends on the accuracy specification you wish to maintain. The Fluke 45 should also be calibrated if it fails the performance test or has undergone repair. To meet the specifications in Chapter 1, the Fluke 45 should be calibrated with equipment meeting the minimum specifications given in Table 4-1.

The following paragraphs first present a basic calibration procedure for use with front panel control. This is followed by a description of editing prompts for different calibration points, then by a description of calibration using the IEEE-488 or RS-232 computer interface.

4-5. Introduction

The basic calibration consists of sets of steps for DC Volts, AC Volts, DC and AC Milliamps, DC and AC Amps, Ohms, Continuity/Hysteresis Threshold, and Frequency. Normally, it is recommended that the entire calibration procedure be performed. However, it is possible to calibrate any function individually. This might be useful during troubleshooting, when looking for a problem in a specific function. Whenever the VDC function is calibrated, the entire calibration procedure for all functions should be performed. Any function except VDC can be calibrated independently without affecting calibration of another function.







If calibration of any function is discontinued prior to completion, no changes are made to nonvolatile calibration memory for that function.



Some calibration steps take longer to execute than others. When the Fluke 45 is executing a calibration step, it ignores all of the front panel buttons and postpones execution of all computer interface commands.

4-6. Entering Calibration Mode

Always begin the calibration procedure as follows:

1. Allow the Fluke 45 to stabilize in an environment with ambient temperature of 18 to 28°C and relative humidity of less than 70%. Then turn the Fluke 45 on, and allow it to warm up for at least 1 hour.
2. The Cal Enable button is located on the right side of the display and is recessed beneath a calibration seal. Enable the calibration mode by pressing the Cal Enable button for about three seconds (CAL appears in secondary display.) Use a small screwdriver or equivalent blunt-tipped object. Avoid using sharper-tipped objects (such as pencils).



When the calibration mode is enabled, the unit first beeps, then displays VDC CAL. From this point the calibration menu can be scrolled to a specific function using the  and  editor buttons. To display the first prompt for the selected calibration function press the  button. In the calibration mode, most buttons are disabled; only the , , and  edit buttons and the Cal Enable button remain active. These buttons are described more fully as follows:





1. Cal Enable button: Enables the calibration mode when pressed for 3 seconds. Exits the calibration mode when pressed momentarily.
2.   Editor buttons: Used to scroll to the desired calibration function in the calibration menu or to edit the displayed calibration prompt.

- Once calibration mode has been entered, the calibration menu appears in the following sequence:



VDC VAC mA DC mA AC A DC A AC Ω V→+ Hz

The menu does not wrap; going from Hz back to V DC can only be accomplished by successively pressing the  button.

- Once  has been pressed to initiate calibration prompting, press either  or  once initially to enter the editor mode. Then use these buttons to edit the calibration prompt value.

The calibration prompt value can be edited by digit. Use  to select the digit to edit. Use  to increment the selected digit. To select a lower digit value, continue incrementing with ; the meter wraps from 9 back to 0. Press  when the edited value is correct.

3.  button: Used to select a calibration function, calibrate (store constants derived from input source into memory), or exit editor mode.

Each time the Fluke 45 prompts you for a reference source, apply the requested source to the appropriate input and COM terminals, allow for both calibrator and meter settling time, and press the  button. When  is pressed, the numeric display field blanks while the Fluke 45 performs the necessary calculations. (Do Not change the reference source while the display is blank.) If the calibration step is successful, the Fluke 45 displays an intensified reading equal to the calibration prompt value before changing to the next prompt.

Note

The meter emits a beep and displays 'Error' if a calibration step fails. Usually, this happens if the reference is not within an anticipated range (5 to 15%, depending on the step.) At this point, the intensified reading equals the raw uncalibrated reading taken on the reference input. Refer to Calibration Failures in Chapter 5 for more information.

4-7. **Exiting Calibration Mode**

Calibration mode can be exited at any time by pressing the Cal Enable button. However, if this button is pressed prior to completion of all calibration points for any function, no changes are made to nonvolatile calibration memory for that function.

If calibration mode is exited after completion of calibration of any function except VDC, constants for other functions are not affected. But remember, whenever VDC is calibrated, the calibration procedure for all other functions should be performed.

To exit the calibration mode, press the Cal Enable button with a small screwdriver or equivalent blunt-tipped object. Avoid using sharper-tipped objects (such as pencils).

4-8. **DC Volts Calibration (Front Panel)**

To perform VDC calibration, proceed as follows:

1. Press the Cal Enable button for 3 seconds to enter the calibration mode. Or, if the meter is already in calibration mode, but set for a different type of calibration, press the  button to return to VDC calibration.
2. Press the **AUTO** button to select the first prompt (0.000 mV DC) for the VDC function.
3. Apply a shorting bar to the **VΩ→+** and COM inputs of the meter and allow 5 seconds for meter settling.



Note

*After voltage is applied to the **VΩ→+** input, the meter can take up to 4 minutes to settle to zero within one microvolt once the voltage is removed. For this reason, no voltage should be applied to the input for 4 minutes before doing zero mV cal.*

4. Push the **AUTO** button to calibrate the meter zero mV calibration point.
5. Remove the short and connect the dc volts source to the **VΩ→+** and COM inputs of the meter.
6. Complete calibration steps 2 through 10 in Table 4-5.





4-9. **AC Volts Calibration (Front Panel)**

To perform ac volts calibration, proceed as follows:

1. If the meter is already in calibration mode, press the  or  button to select VAC calibration. Otherwise, select calibration mode first (press Cal Enable button for three seconds), then select VAC calibration by pressing the  button once.
2. Connect the ac source to the **VΩ→+** and COM inputs of the meter.
3. For each of steps 11 through 17 (Table 4-5), apply the source output indicated and calibrate the meter by pressing the **AUTO** button.

4-10. **DC and AC Milliamp Calibration (Front Panel)**

Perform the dc and ac milliamps calibration as follows:

1. If the meter is already in calibration mode, press the  or  button to select mA DC calibration. Otherwise, select calibration mode first (press Cal Enable button for three seconds), then select mA DC calibration by pressing the  button twice.
2. Connect the dc milliamps source to the [100 mA] and COM inputs.
3. Apply the dc milliamp outputs indicated in Table 4-5 (steps 18 and 19), and calibrate the meter with the **AUTO** button.
4. Press the  button to select mA AC calibration.

5. Connect the ac milliamps source to the [100 mA] and COM inputs.
6. Apply the ac milliamp outputs indicated in Table 4-5 (steps 20 and 21), and calibrating each step by pressing the **(AUTO)** button.

Table 4-5. Front Panel Calibration

<i>Note</i>			
<i>Before proceeding, allow for settling time of at least 30 seconds with no input applied.</i>			
Step	Meter Cal Prompt	Source Input	Meter Settling Time Before Pressing (AUTO)
DC Volts Calibration			
1	0.000 mV DC	short	5 s
2	90.000 mV DC	90 mV dc	2 s
3	-90.000 mV DC	-90 mV dc	2 s
4	900.00 mV DC	900 mV dc	2 s
5	90.000 mV DC	90 mV dc	5 s
6	290.00 mV DC	290 mV dc	1 s
7	2.9000 V DC	2.9 V dc	1 s
8	29.000 V DC	29 V dc	1 s
9	290.00 V DC	290 V dc	1 s
10	1000.0 V DC	1000 V dc	1 s
<i>Note</i>			
<i>Settling times mentioned here assume that steps 1 through 32 are followed in sequence. If you have just calibrated dc volts (steps 1 through 10), but do not follow the subsequent sequence, a special settling period of 4 minutes may be required due to dielectric absorption caused by the 1000 V dc input in step 10. Examples of this requirement include re-checking dc volts calibration (going from step 10 back to step 1) or skipping to ohms calibration (going from step 10 to step 25.)</i>			
AC Volts Calibration			
11	29.000 mV AC	29 mV 1 kHz	3 s
12	290.00 mV AC	290 mV 1 kHz	3 s
13	0.2900 V AC	290 mV 1 kHz	3 s
14	2.9000 V AC	2.9 V 1 kHz	3 s
15	29.000 V AC	29 V 1 kHz	3 s
16	290.00 V AC	290 V 1 kHz	3 s
17	750.00 V AC	750 V 1 kHz	3 s
DC Milliamps Calibration			
18	29.000 mA DC	29 mA dc	1 s
19	100.00 mA DC	100 mA dc	1 s
AC Milliamp Calibration			
20	29.000 mA AC	29 mA 1 kHz	3 s
21	100.00 mA AC	100 mA 1 kHz	3 s
DC and AC Amps Calibration			
22	10.000 A DC	10 A DC	3 s
23	2.000 A AC	2 A 1 kHz	5 s
24	10.000 A AC	10 A 1 kHz	5 s

Table 4-5. Front Panel Calibration (cont)

Ohms Calibration				
Step	Initial Meter Cal Prompt	5700A Source Output	Edit Meter Cal Prompt To:	Meter Settling Time Before Pressing
25	290.00 Ω	190 Ω*	5700A Display	1 s
26	2.9000 kΩ	1.9 kΩ	"	1 s
27	29.000 kΩ	19 kΩ	"	2 s
28**	290.00 kΩ	190 kΩ	"	3 s
29**	2.9000 MΩ	1.9 MΩ	"	3 s
Continuity/Hysteresis Threshold Calibration				
Step	Meter Cal Prompt	Source Output	Meter Settling Time Before Pressing	
30	0.000 V	0.000 mV	1 s	
31	0.020 V	20.00 mV	1 s	
Frequency Calibration				
32	2.000 V p-p	10 kHz	2 s	
<p>* A 190 Ω source calibrates the 300 Ω range on the Fluke 45 to 0.06%+2 digits +0.02 Ω. For calibration of this range to 0.05%+2 digits +0.02 Ω, use a 290 Ω source and the procedure detailed under Alternate Ohms Calibration (Front Panel). This procedure can also be used with appropriate discrete resistor values (such as a decade box) on all ranges.</p> <p>** Note that the 300 kΩ and 3 MΩ ranges are quite sensitive to noise. Any movement of the input leads or movement of the hands or body in the vicinity of the leads can cause noisy readings. This causes an error in the calibration if the button is pushed during a bad reading. To avoid this, use shielded leads during this calibration and hold very steady for several seconds with your index finger resting on the button before pressing it. These two cal points should be verified for accuracy at the conclusion of calibration.</p>				

4-11. DC and AC Amps Calibration (Front Panel)





The dc and ac amps calibration requires a boost amplifier or transconductance amplifier capable of 10 A output at both dc and 1 kHz.

1. If the meter is already in calibration mode, press the or button to select A DC calibration. Otherwise, select calibration mode first (press Cal Enable button for three seconds), then select A DC calibration by pressing the button four times.
2. Connect the output of the boost amplifier to the [10 A] and COM inputs of the meter.
3. Apply the dc amp output indicated in Table 4-5 (step 22), and calibrate using the button.
4. Select A AC calibration on the meter by pressing the button once.
5. Apply the two ac amp outputs called for in steps 23 and 24 of Table 4-5, calibrating each step by using the button.

4-12. Ohms Calibration (Front Panel)

If you do not have the value resistors (290 Ω, 2.9 kΩ, 29 kΩ, etc.) required by the Fluke 45 calibration prompts, the requested value (prompt) must be edited to the value available. (See "Editing the Prompt for Different Calibration Points", later in this

chapter.) In the following procedure, the Fluke 5700A Multifunction Calibrator is used as the ohms source, with input values of 190 Ω , 1.9 k Ω , 19 k Ω , 190 k Ω , and 1.9 M Ω .

1. If the meter is already in calibration mode, press the  or  button to select Ω calibration. Otherwise, select calibration mode first (press Cal Enable button for three seconds), then select Ω calibration by pressing the  button six times.
2. Connect the ohms source to the meter in a four-wire configuration. Refer to Figure 4-1.
3. On the 5700A, select 2-wire compensation ON, with external sense. Then program the 5700A for the output in step 25 of Table 4-5.
4. Edit the meter prompt display to read the same value as the 5700A output display.
5. On the meter, press the  button to calibrate this step. Then continue with steps 26 through 29 in Table 4-5.

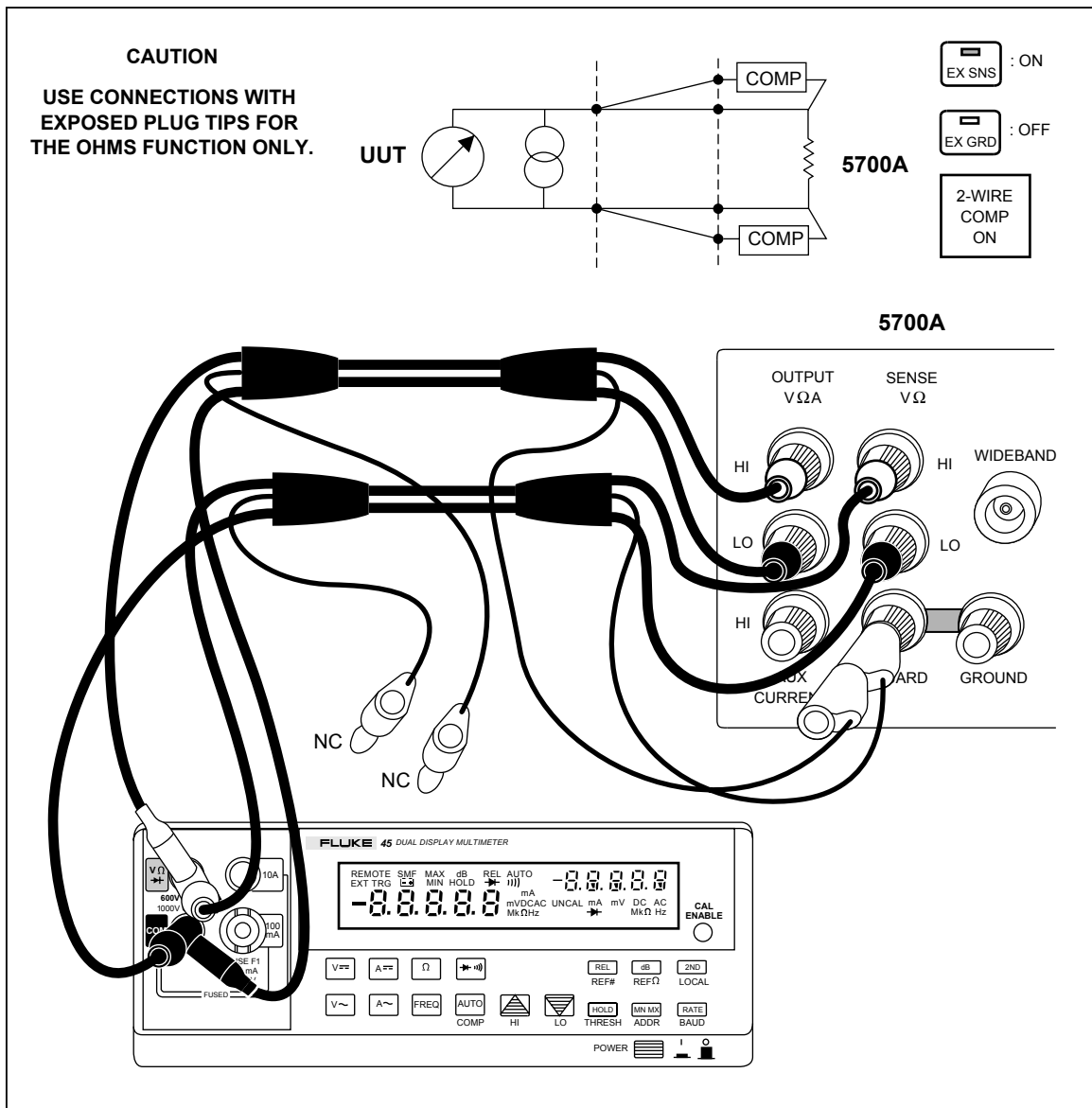

qb18f.eps

Figure 4-1. Four-Wire Configuration



4-13. Alternate Ohms Calibration (Front Panel)

The following procedure can be used with discrete resistor values (such as a decade box). On the 300 Ω range, this alternate procedure uses a 290 Ω source and yields a specification of 0.05%+2 digits +0.02 Ω . Alternate calibration of this range is detailed below, although discrete resistor values can be used for all ranges. Lead and source zero resistances are only taken into account for the lowest two ranges (300 Ω and 3 k Ω).



1. Connect the ohms source to the meter. Apply zero ohms.
2. Measure and record the residual lead and source zero resistance on the 300 Ω range.
3. Add the value from the lead and source zero resistance from step 2 above to the certified value of the source resistor.
4. Set the meter to the calibration mode (press the Cal Enable button.) Select ohms calibration.
5. Using the editor buttons, edit the meter display prompt to the value calculated in step 3.
6. Press **AUTO** to calibrate this range.

4-14. Continuity/Hysteresis Threshold Calibration (Front Panel)

Perform the calibration as follows:

1. If the meter is already in calibration mode, press the  or  button to select **V \rightarrow +** calibration. Otherwise, select calibration mode first (press Cal Enable button for three seconds), then select **V \rightarrow +** calibration by pressing the  button seven times.
2. Connect the output of the dc voltage source to the **V Ω \rightarrow +** and COM input of the meter.
3. Apply the outputs indicated in Table 4-5, and calibrate using the **AUTO** button.

4-15. Frequency Calibration (Front Panel)

If the meter is already in calibration mode, press the  button to select Hz calibration. Otherwise, select calibration mode first (press Cal Enable button for three seconds), then select Hz calibration by pressing the  button eight times. Complete step 32 of Table 4-5

4-16. C2 Adjustment Procedure

The following procedure can be performed on meters that fail to meet the performance test limits for high frequency VAC. The procedure is performed separately after all other VAC calibration steps are completed. It is not necessary to enter the calibration mode to adjust C2.

1. Remove the top shield (MP11).
2. Set the UUT to VAC
3. Apply 15 mV, 1 kHz to the UUT input.
4. Record the UUT display reading.
5. Apply 15 mV, 20 kHz to the UUT input.
6. Adjust C2 until the UUT display reads 40 μ V less than the reading recorded in Step 4.

7. Remove the adjustment tool from the vicinity of C2 and let the reading settle.
8. The reading should remain stable.
9. Readjust if necessary.
10. Re-install the top shield (MP11).
11. Complete the performance test for ACV.

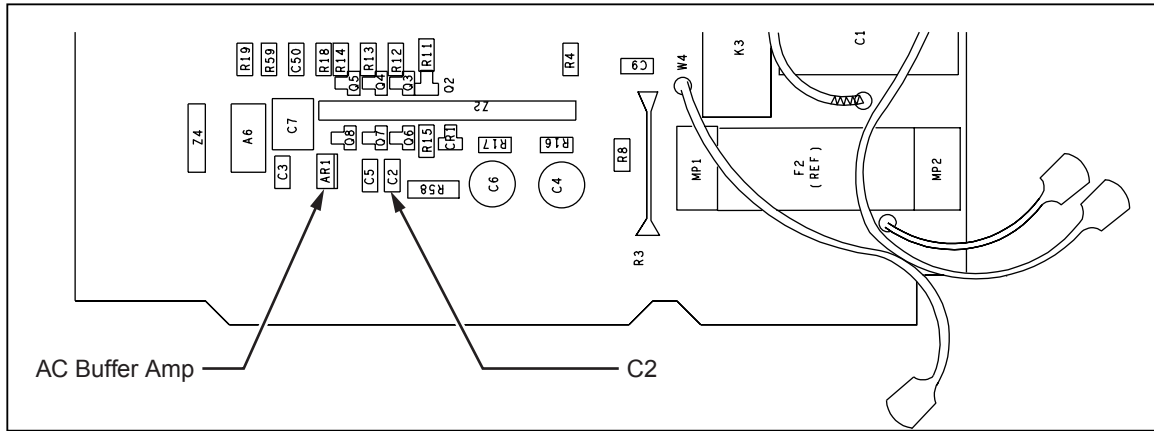





Figure 4-2. C2 Location

qb58sc.eps

4-17. Editing the Prompt for Different Calibration Points

Except for the first three prompts in VDC (0.000 mV, +90.000 and -90.000 mV are calibration constants), the Fluke 45 can be calibrated using calibration points other than the prompted values. To do this, you must edit the prompt to the reference source value as follows:

1. Press the  editor button. This intensifies the left-most digit of the numeric display and turns the EDIT annunciator on.
2. Press the  editor button to increment the intensified digit from 0-9.
3. Press the  editor button again to intensify the next digit to be edited.
4. Once the edited value is equal to the reference source value, push the **AUTO** button to exit the edit mode.

Holding down the editor buttons causes continual incrementing until the button is released.

For calibration at points other than full scale, you must account for the effect of non-linearity and noise on the accuracy specifications. This effect is expressed as a percentage added to the Fluke 45 specification.

Table 4-6 shows additional errors to be added to the specifications when calibration is conducted at points other than full range.

For example, if ohms is calibrated using decades of 1.9 (190 Ω , 1.9 k Ω , etc.), the additional error on the 300 Ω and 100 Ω ranges is 0.01%. Therefore, since calibration has been performed at less than full scale, 0.01% must be added to the Fluke 45 300 Ω and 100 Ω range accuracy to arrive at the new specification.

Note that the first three calibration points (0, 90 mV, and -90 mV) cannot be edited. Also, to provide accuracy at full range, calibration is not recommended below one-third of full range (10000 counts).

Table 4-6. Specifications Increase with Different Calibration Points

Function	Cal Point In Display Counts		
	20000	19000	10000
DC	.006%	.006%	.012%
AC	.045%	.05%	.09%
300 Ω/100 Ω	.01%	.01%	.02%
kΩ/MΩ	-	-	.01%

4-18. Calibration Using the Computer Interface

4-19. Setup

Before performing this type of calibration, make sure that computer interface connections are made to the Fluke 45. Then verify the ac power connection to the Fluke 45, and turn the meter on.

4-20. RS-232 Interface

For RS-232 interface operation, use the following procedure from the front panel:

1. Press **[2ND]**, then press **[RATE]**.
2. Use **[▲]** or **[▼]** to scroll to the desired baud rate. Then press **[AUTO]** to select the displayed rate.
3. Use **[▲]** or **[▼]** to scroll to the desired parity ("E" for even, "Odd" for odd, or "no" for none.) Then press **[AUTO]** to select the displayed parity.
4. Use **[▲]** or **[▼]** to display "OFF" or "On" for command echo mode. Then press **[AUTO]** to make the selection.

5. Send the following command from the computer interface:

```
*IDN?<CR>
```

6. Check for a response in the following format:

```
FLUKE, 45, nnnnnnn, n.n Dn.n <CR><LF> =><CR><LF>
```

where 'nnnnnnn' is the multimeter serial number, 'n.n' identifies the main software version, 'Dn.n' identifies the display software version, and '=>' is the RS-232 prompt.

If echo mode is ON, the response to the CALSTEP? command called for in Table 4-7 (step 12) appears in the form:

```
CALSTEP?<CR><LF>
+290.00E-3<CR><LF>
=><CR><LF>
```

where => is the prompt returned by the Fluke 45. The response to CALREF? also follows this format.

4-21. IEEE-488 Interface

For IEEE-488 interface operation, use the following front panel procedure:

1. Press **2ND**, then press **RATE**.
2. Use  to scroll to "IEEE". Then press **AUTO** to enable the IEEE-488 interface.
3. Send the following to the meter over the IEEE-488 bus:

Note

The following example uses Fluke BASIC commands entered from a Fluke 1722A Instrument Controller. Syntax may vary for other controllers.

```
INIT PORT 0<CR>
CLEAR PORT 0<CR>
PRINT @<address of meter>,"*IDN?"<CR>
INPUT LINE @<address of meter>,A$<CR>
PRINT A$<CR>
```

4. Check for the following response format:

FLUKE, 45, nnnnnnn, n.n Dn.n

where 'nnnnnnn' is the multimeter serial number, 'n.n' identifies the main software version, and 'Dn.n' identifies the display software version.

Table 4-7. Calibration Using the Computer Interface

<i>Note</i>					
<i>Before proceeding, allow for settling time of at least 30 seconds with no input applied.</i>					
Step	Apply Input	Wait For Meter Settling Time	Send		
1	0.0000 mV dc	5 s	CALSTEP?		
2	90.000 mV dc	2 s	CALSTEP?		
3	-90.000 mV dc	2 s	CALSTEP?		
4	900.00 mV dc	2 s	CALSTEP?		
5	90.000 mV dc	5 s	CALSTEP?		
6	290.00 mV dc	1 s	CALSTEP?		
7	2.9000 V dc	1 s	CALSTEP?		
8	29.000 V dc	1 s	CALSTEP?		
9	290.00 V dc	1 s	CALSTEP?		
10	1000.0 V dc	1 s	CALSTEP?		
<i>Note</i>					
<i>Settling times mentioned here assume that steps 1 through 32 are followed in sequence. If you have just calibrated dc volts (steps 1 through 10), but do not follow the subsequent sequence, a special settling period of 4 minutes may be required due to dielectric absorption caused by the 1000 V dc input in step 10. Examples of this requirement include re-checking dc volts calibration (going from step 10 back to step 1) or skipping to ohms calibration (going from step 10 to step 25.)</i>					
AC Volts Calibration					
11	29.000 mV ac, 1 kHz	3 s	CALSTEP?		
12	290.00 mV ac, 1 kHz	3 s	CALSTEP?		
13	290.00 mV ac, 1 kHz	3 s	CALSTEP?		
14	2.9000 V ac, 1 kHz	3 s	CALSTEP?		
15	29.000 V ac, 1 kHz	3 s	CALSTEP?		
16	290.00 V ac, 1 kHz	3 s	CALSTEP?		
17	750.00 V ac 1 kHz	3 s	CALSTEP?		
DC Milliamps Calibration					
18	29.000 mA DC	1 s	CALSTEP?		
19	100.00 mA DC	1 s	CALSTEP?		
DC Amps Calibration					
22	10.000 A DC	3 s	CALSTEP?		
AC Amps Calibration					
23	2.000 A AC, 1 kHz	5 s	CALSTEP?		
24	10.000 A AC, 1 kHz	5 s	CALSTEP?		
Ohms Calibration					
Step	Range	Input	Wait for Meter Settling Time	Send	Send
25	1	190.0 Ω*	1 s	CALREF xxx.xx	CALSTEP?
26	2	1.900 kΩ	1 s	CALREF xxxx.x	CALSTEP?
27	3	19.00 kΩ	2 s	CALREF xxxxx	CALSTEP?
28**	4	190.0 kΩ	3 s	CALREF xxxxxx	CALSTEP?
29**	5	1.900 MΩ	3 s	CALREF xxxxxxxx	CALSTEP?

Table 4-7. Calibration Using the Computer Interface (cont)

Continuity/Hysteresis Threshold Calibration			
Step	Apply input	Wait for meter settling time	Send
30	0.000 mV dc	1 s	CALSTEP?
31	20.00 mV dc	1 s	CALSTEP?
Frequency Calibration			
32	10 kHz, 2.000 V p-p	2 s	CALSTEP?
(xxxx... represents the known exact ohms value of the source)			
* A 190 Ω source calibrates the 300 Ω range on the Fluke 45 to 0.06%+2 digits +0.02 Ω . For calibration of this range to 0.05%+2 digits +0.02 Ω , use a 290 Ω source and the procedure detailed under Alternate Ohms Calibration (Computer Interface). This procedure can also be used with appropriate discrete resistor values (such as a decade box) on all ranges.			
** Note that the 290 k Ω and 2.9 M Ω ranges are quite sensitive to noise. Any movement of the input leads or movement of the hands or body in the vicinity of the leads can cause noisy readings. Use shielded leads during this calibration. These two cal points should be verified for accuracy at the conclusion of calibration.			

4-22. The Calibration Procedure

Now select calibration mode on the Fluke 45. Using a thin, blunt-tipped object, press the recessed Cal Enable button for three seconds. Avoid using sharp objects that might damage this button. Refer to Table 4-8 for brief descriptions of calibration mode commands.

The CALREF xxx.xx command tells the Fluke 45 to change the calibration prompt to the exact value of the input from the calibrator. Use of this command is equivalent to the act of editing the calibration prompt from the front panel when other than exact calibration points are to be used.

The CALSTEP? command normally returns the calibrated value of the input. If the input is not within an anticipated range of the expected value (5 to 15%, depending on the step), a beep is sounded at the front panel, a device dependent error is returned over the computer interface, and the measured reading is returned.

The response to CALSTEP? must be received before each new step can begin. With some steps (such as step 31), a noticeable delay may be encountered.

Before beginning calibration, consider the functions that will be affected. AC volts, dc amps, ac amps, and ohms are all influenced by dc volts calibration. If you calibrate dc volts, you must re-calibrate these other functions. But, calibration of ac volts, dc amps, ac amps, and/or ohms influences only the function being calibrated.

If you plan to include the ohms function in your calibration procedure, determine the residual lead and source zero resistance before you place the meter in calibration mode. Use the following procedure:

1. Send: OHMS; RANGE 1
2. Measure the residual lead and source zero resistance on the 300 Ω range by sending: VAL?
3. Record the response. This value is used if you elect to perform the Alternate Ohms Calibration.
4. Now continue on with the calibration procedures in the following paragraphs.

4-23. DC Volts Calibration (Computer Interface)

1. Connect the DC Calibrator to the Fluke 45 **VΩ→** and COM inputs. Then send:
CAL 1
2. Complete steps 1 through 10 in Table 4-7. Then clear the dc volts source.

4-24. AC Volts Calibration (Computer Interface)

1. Connect the AC Calibrator to the Fluke 45 **VΩ→** and COM inputs. Then send:
CAL 2
2. Complete steps 11 through 17 in Table 4-7. Then clear the ac volts source.

4-25. DC and AC Milliamps Calibration (Computer Interface)

1. Connect the mA Calibrator to the Fluke 45 [100 mA] and COM inputs. Then send:
CAL 3
2. Complete steps 18 and 19 in Table 4-7.
3. Now send:
CAL 4
4. Complete steps 20 and 21 in Table 4-7. Then clear the milliamp source.

4-26. DC and AC Amps Calibration (Computer Interface)

1. Connect the Amps Calibrator to the Fluke 45 [10 A] and COM inputs. Then send:
CAL 5
2. Complete step 22 in Table 4-7.
3. Clear the dc amps source. Then send:
CAL 6
4. Complete steps 23 and 24 in Table 4-7, and clear the amps source.

4-27. Ohms Calibration (Computer Interface)

If you do not have the value resistors (290 Ω, 2.9 kΩ, 29 kΩ, etc.) required by the Fluke 45 calibration prompts, the requested value (prompt) may be set to the value available. In the following procedure, the Fluke 5700A Multifunction Calibrator is used as the ohms source, with input values of 190 Ω, 1.9 kΩ, 19 kΩ, 190 kΩ, and 1.9 MΩ.

Note

If you are using an ohms calibrator without active 2-wire compensation, take a zero ohms measurement before entering calibration mode. Use the test leads that will be used for ohms calibration. Record this zero ohms value. The CALREF xxx.xx command tells the Fluke 45 to calibrate to the exact ohms value of the calibrator resistance. For the 290 Ω and 2.9 kΩ steps, xxx.xx should be the calibrator value plus the recorded zero ohms value.

1. Connect the Ohms Calibrator to the Fluke 45 **VΩ→** and COM inputs. Then send:
CAL 7

Note that the 300 k Ω and 3 M Ω ranges are quite sensitive to noise. Any movement of the input leads or movement of the hands or body in the vicinity of the leads can cause noisy readings. Use shielded leads during this calibration. Verify these two calibration points for accuracy at the conclusion of the calibration procedure.

- Complete steps 25 through 29 in Table 4-7. Then clear the ohms source.

4-28. Continuity/Hysteresis Threshold Calibration (Computer Interface)

- Connect the DC Volts Calibrator to the Fluke 45 **V Ω - \rightarrow +** and COM inputs. Then send:
CAL 8
- Complete steps 30 and 31 in Table 4-7, and clear the source.

4-29. Frequency Calibration (Computer Interface)

- Connect the Frequency Calibrator to the Fluke 45 **V Ω - \rightarrow +** and COM inputs. Then send:
CAL 9
- Complete step 32 in Table 4-7. Then clear the frequency source.

4-30. Concluding Calibration Using the Computer Interface

At the conclusion of this type of calibration, first make sure the source is cleared. Then press the Cal Enable button on the meter to exit calibration mode.

Calibration mode can also be exited at any time by sending the *RST command. If this command is sent prior to completion of all calibration points for the selected function, no changes are made to nonvolatile calibration memory for that function.

If calibration mode is exited after completion of calibration of any function except VDC, constants for other functions are not affected. But remember, whenever VDC is calibrated, the calibration procedure for all other functions should be performed.

4-31. Alternate Ohms Calibration (Computer Interface)

This procedure can be used with discrete resistor values (such as a decade box). On the 300 Ω range, this alternate procedure uses a 290 Ω source and yields a specification of 0.05%+2 digits +0.02 Ω . Alternate calibration of this range is detailed below, although discrete resistor values can be used for all ranges. Lead and source zero resistances are only taken into account for the lowest two ranges (300 Ω and 3 k Ω).

- Add the value of lead and source zero resistance to the certified value of the source resistor. Lead and source zero resistance is the value obtained with the VAL? command, immediately prior to entering dc volts calibration. Use this total value as 'xxx.xx' in the following command:

CALREF xxx.xx

- Now send

CALSTEP?

Table 4-8. Calibration Mode Computer Interface Commands

CAL x	<p>Start calibration of a new function, where x = 1 through 9, defined as follows:</p> <ol style="list-style-type: none"> 1 VDC calibration 2 VAC calibration 3 DC Milliamps calibration 4 AC Milliamps calibration 5 DC Amps calibration 6 AC Amps calibration 7 Ohms calibration 8 Frequency comparator 9 Frequency calibration
CALCLR CALCONST? xx CALREF? CALREF xxx.xx CALSTEP? EEREG? xx	<p>Reset all calibration constants to nominal values, destroying present calibration.</p> <p>Return the value of the calibration constant indicated by xx. See Table 4-9.</p> <p>Return the present calibration reference.</p> <p>Calibrate to the exact value xxx.xx, rather than the nominal (expected) cal value.</p> <p>Return the calibrated value of the input.</p> <p>Return the contents of the specified EEROM register (xx).</p>
<p>The following additional computer interface commands can be used in Calibration Mode. Use of any other command results in an execution error.</p>	
*CLS *ESE *ESE? *ESR? *IDN? *OPC *OPC? *RST *SRE *SRE? *STB? *TRG *WAI	BUTTON? FORMAT? LOCS LWLS REMS RWLS SERIAL? FORMAT VAL? VAL1?

Table 4-9. EEROM Calibration Constants

Calconst?	Valid Range	Description
1	0.97025 to 1.03775	VDC, range 1
2	0.97025 to 1.03775	VDC, range 2
3	0.97267 to 1.04554	VDC, range 3
4	0.96782 to 1.04035	VDC, range 4
5	0.96792 to 1.04045	VDC, range 5
6	0.9975 to 1.0025	100 mV gain
7	0.9975 to 1.0025	320 mV gain
8	0.9975 to 1.0025	3.2 V gain
9	-100 to 100	VAC offset, range 1
10	0.9725 to 1.0275	VAC, range 1
11	-100 to 100	VAC offset, ranges 2 through 4
12	0.9725 to 1.0275	VAC, range 2
13	0.9725 to 1.0275	VAC, range 3
14	0.9725 to 1.0275	VAC, range 4
15	0.9725 to 1.0275	VAC, range 5
16	0.9500 to 1.0500	ADC, range 1
17	0.9500 to 1.0500	ADC, range 2
18	0.9500 to 1.0500	ADC, range 3
19	0.9225 to 1.0775	AAC, range 1
20	0.9225 to 1.0775	AAC, range 2
21	-100 to 100	AAC offset, range 3
22	0.9225 to 1.0775	AAC, range 3
23	0.9990 to 1.0090	OHMS, range 1
24	1.0000 to 1.0100	OHMS, range 2
25	1.0040 to 1.0140	OHMS, range 3
26	0.9990 to 1.0090	OHMS, range 4
27	0.9990 to 1.0090	OHMS, range 5
28	0.9990 to 1.0090	OHMS, range 6
29	0.9886 to 1.0035	Slow Siemens
30	0.9910 to 1.0010	Medium and Fast Siemens
31	0.9999 to 1.0001	Frequency calibration
32	-10.0 to 10.0	Slow offset
33	1.0000 to 1.0006	Slow negative gain

Chapter 5

Diagnostic Testing and Troubleshooting

	Title	Page
5-1.	Introduction.....	5-3
5-2.	Servicing Surface-Mount Assemblies	5-3
5-3.	Error Codes	5-4
5-4.	General Troubleshooting Procedures	5-10
5-5.	Power Supply Troubleshooting	5-10
5-6.	Raw DC Supply.....	5-10
5-7.	5-Volt Switching Supply.....	5-11
5-8.	Inverter	5-12
5-9.	Analog Troubleshooting.....	5-13
5-10.	Uart Test.....	5-13
5-11.	DC Volts Troubleshooting	5-14
5-12.	AC Volts Troubleshooting	5-14
5-13.	Ohms Troubleshooting.....	5-14
5-14.	Digital Troubleshooting	5-15
5-15.	Display Assembly Troubleshooting.....	5-17
5-16.	Calibration Failures	5-19
5-17.	Introduction	5-19
5-18.	Calibration-Related Components	5-20
5-19.	Calibration Interrelationships	5-21
5-20.	Retrieving Calibration Constants	5-21
5-21.	Replacing the EEROM A1U5	5-21

5-1. Introduction

The Fluke 45 provides error code information and semi-modular design to aid in troubleshooting. This chapter explains the error codes and describes procedures needed to isolate a problem to a specific functional area. Finally, troubleshooting hints for each functional area are presented.

But first, if the meter fails, check the fuses and replace as needed. If the problem persists, verify that you are operating the meter correctly by reviewing the operating instructions found in the User's Manual.

⚠ Warning

Opening the case may expose hazardous voltages. Always disconnect the power cord and measuring inputs before opening the case. And remember that repairs or servicing should be performed only by qualified personnel.

Required equipment is listed in Chapter 4 of this manual.

Signal names followed by a '*' are active (asserted) low. Signal names not so marked are active high.

5-2. Servicing Surface-Mount Assemblies

The 45 Dual Display Multimeter incorporates Surface-Mount Technology (SMT) for printed circuit assemblies (pca's). Surface-mount components are much smaller than their predecessors, with leads soldered directly to the surface of a circuit board; no plated through-holes are used. Unique servicing, troubleshooting, and repair techniques are required to support this technology. The information offered in the following paragraphs serves only as an introduction to SMT. It is not recommended that repair be attempted based only on the information presented here.

Since sockets are seldom used with SMT, "shotgun" troubleshooting cannot be used; a fault should be isolated to the component level before a part is replaced. Surface-mount assemblies are probed from the component side. The probes should make contact only with the pads in front of the component leads. With the close spacing involved, ordinary test probes can easily short two adjacent pins on an SMT IC.

This Service Manual is a vital source for component locations and values. With limited space on the circuit board, chip component locations are seldom labeled. Figures provided in Chapter 6 of this manual provide this information. Also, remember that chip components are not individually labeled; keep any new or removed component in a labeled package.

Surface-mount components are removed and replaced by reflowing all the solder connections at the same time. Special considerations are required.

- Use a solder tool with regulated hot air to melt the solder; there is no direct contact between the tool and the component.
- Surface-mount assemblies require rework with wire solder rather than with solder paste. A 0.025 inch diameter wire solder composed of 63% tin and 37% lead is recommended. A 60/40 solder is also acceptable.

A good connection with SMT requires only enough solder to make a positive metallic contact. Too much solder causes bridging, while too little solder can cause weak or open solder joints. With SMT, the anchoring effect of the through-holes is missing; solder provides the only means of mechanical fastening. Therefore, the pca must be especially

clean to ensure a strong connection. An oxidized pca pad causes the solder to wick up the component lead, leaving little solder on the pad itself.

5-3. Error Codes

At reset, the Fluke 45 software attempts power-up self-tests and initialization of ROM, RAM, Display, EEROM, and measurement hardware. Self-test failures are reported on the display with "error" in the secondary display and an error code (1-9) in the primary display.

Several of these error codes might never be displayed. Certainly, errors 4 and 5, which signify a faulty or dead display, could not be reported in the normal (displayed) manner. Other errors might not appear on the display.

The keyboard scan lines (A1U6, SWR1-5), which are also used as status indicators, can be checked as a last resort for accessing error information. The software sets SWR1 (A1U6-21) low to indicate that the basic operation of the processor, ROM, and ROM decode circuitry is intact. SWR2 (A1U6-22) is set low if the ROM check passes. SWR3 (A1U6-23) is set low if the external RAM (A1U10) check passes, and SWR4 (A1U6-24) is set low if the internal RAM (A1U6) check passes. Then, if the display self-check passes, SWR5 (A1U6-25) is set low to indicate that the display is operational.

Table 5-1 describes the error codes.

Note

Each error code is displayed for 2 seconds. Any button press during this period aborts the error display

Table 5-1. Error Codes

Error No.	Meaning
1	ROM test failed
2	External RAM test failed
3	Internal RAM test failed
4	Display self-test failed
5	Display dead
6	EEROM meter configuration corrupted
7	EEROM calibration data corrupted ("UNCAL" annunciator also lights)
8	A/D chip dead
9	Measurement self-test failed
Refer to Troubleshooting information later in this chapter.	
Error 1	ROM (A1U8) checksum match failed. All the bytes in the ROM (including a checksum byte) are summed
Error 2	External RAM (A1U10) check failed.
Error 3	Internal RAM (A1U6) check failed. Complementary patterns are alternately written and read from each RAM location for both external RAM and the 256 bytes internal to the 6303Y Main Processor (A1U6). If the pattern read from any RAM location is not the same as the pattern written, the test fails.
Error 4	Display self-check failed
Error 5	Display dead. The display processor automatically performs a self-check on power-up, and the Main Processor attempts to read the result of this test.
Error 6	EEROM (A1U5) meter configuration corrupted or EEROM not initialized. At power up, A1U6 reads CRC from EEROM (A1U5) location, then reads configuration data from another location in EEROM, calculates an algorithm to compare to the CRC. If an error is determined, the meter configuration is set to factory default and Error 6 is displayed.
Error 7	EEROM (A1U5) calibration data corrupted. The EEROM is divided into two storage areas: the default meter configuration storage and calibration data storage. Each area uses a Cyclic Redundancy Checksum, against which the data is checked on power-up. In addition, the calibration data includes parity information for each calibration constant, which is also checked. If the meter configuration check finds an error, the meter configuration is set to factory defaults, and Error 6 is reported. If the parity check or the calibration data checksum finds an error, the front panel UNCAL annunciator is turned on, and Error 7 is reported. <i>Note</i> <i>Errors 6 and 7 should always appear the first time a meter is powered up with a new, uninitialized EEROM. Error 7 continues to appear at subsequent power-ups until the meter is fully calibrated.</i>
Error 8	Analog Measurement Processor (A1U1) dead.
Error 9	Measurement self-check failed. The Analog Measurement Processor is programmed to do self test measurements. If the Analog Measurement Processor does not respond, it is considered dead.

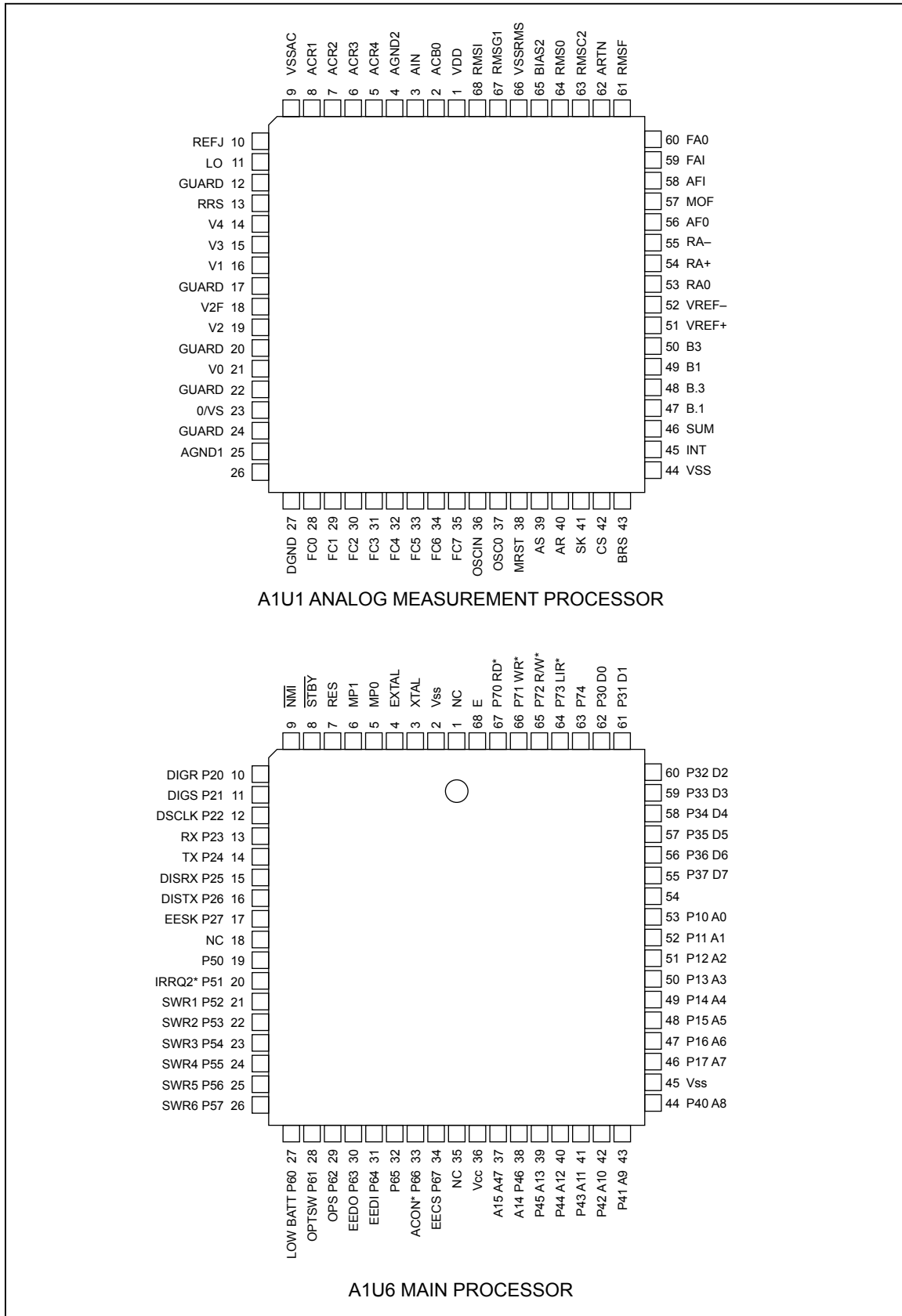

qb19f.eps

Figure 5-1. Test Point Locator

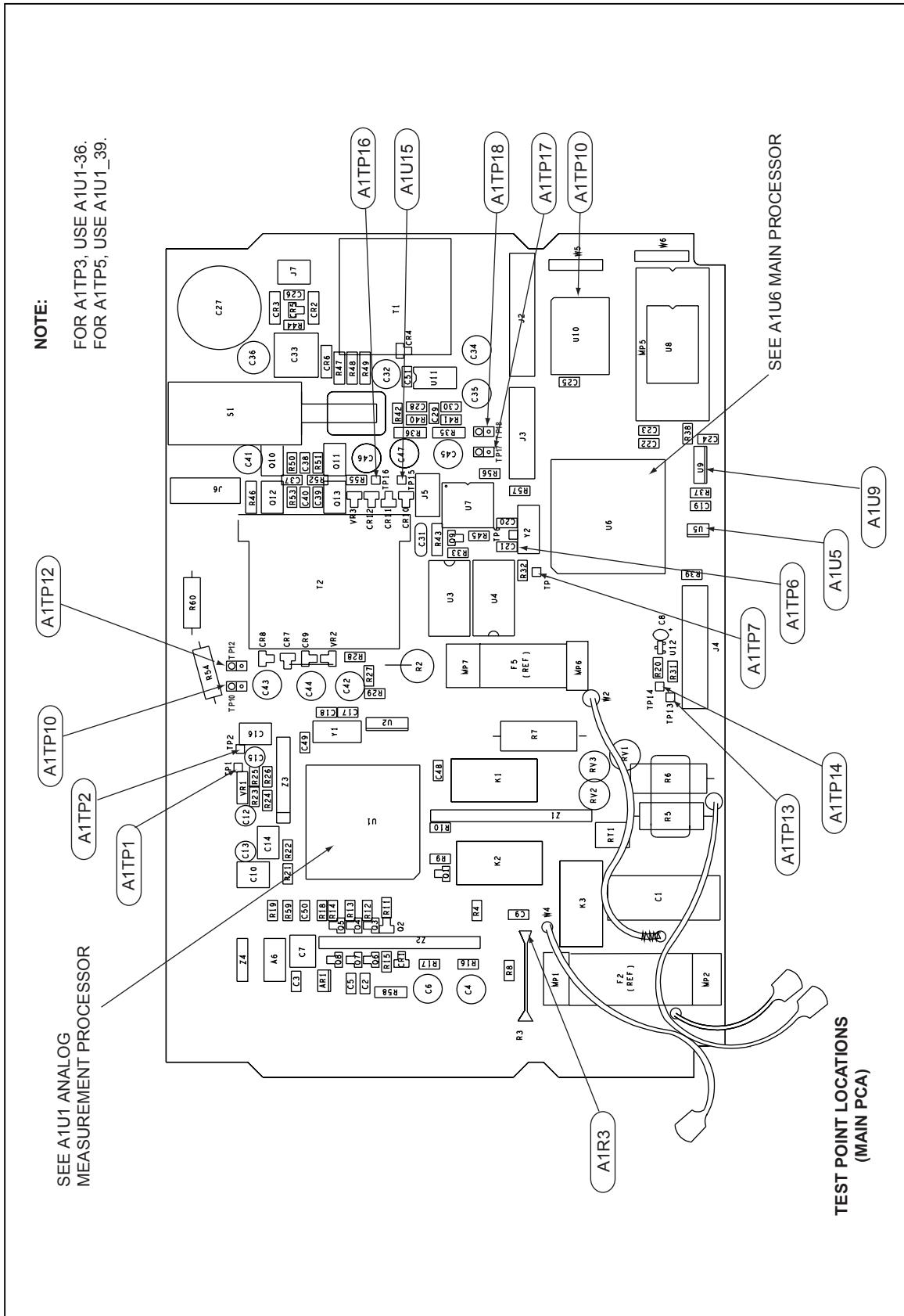

qb20c.eps

Figure 5-1. Test Point Locator (cont)

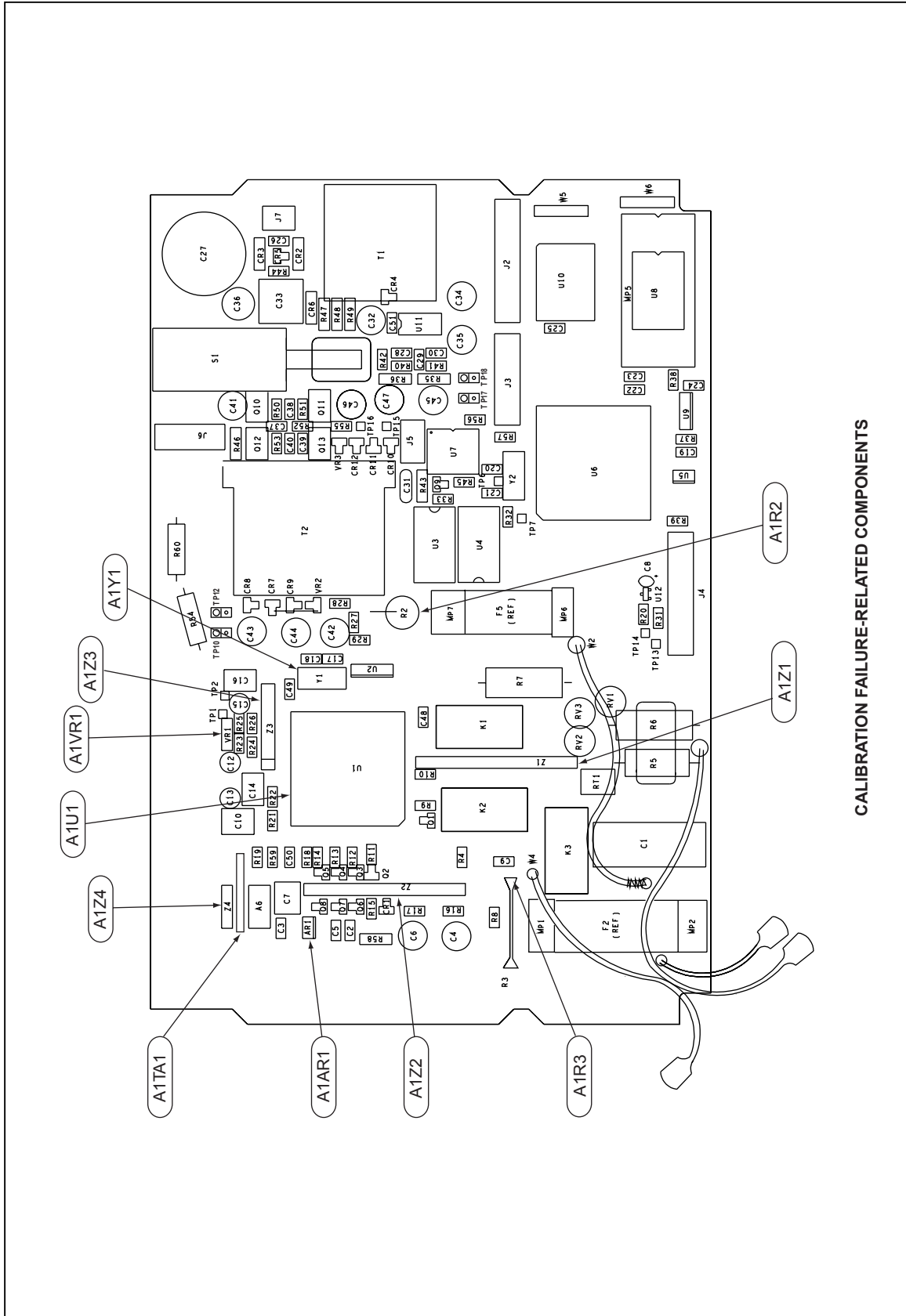

Figure 5-1. Test Point Locator (cont)

qb21c.eps

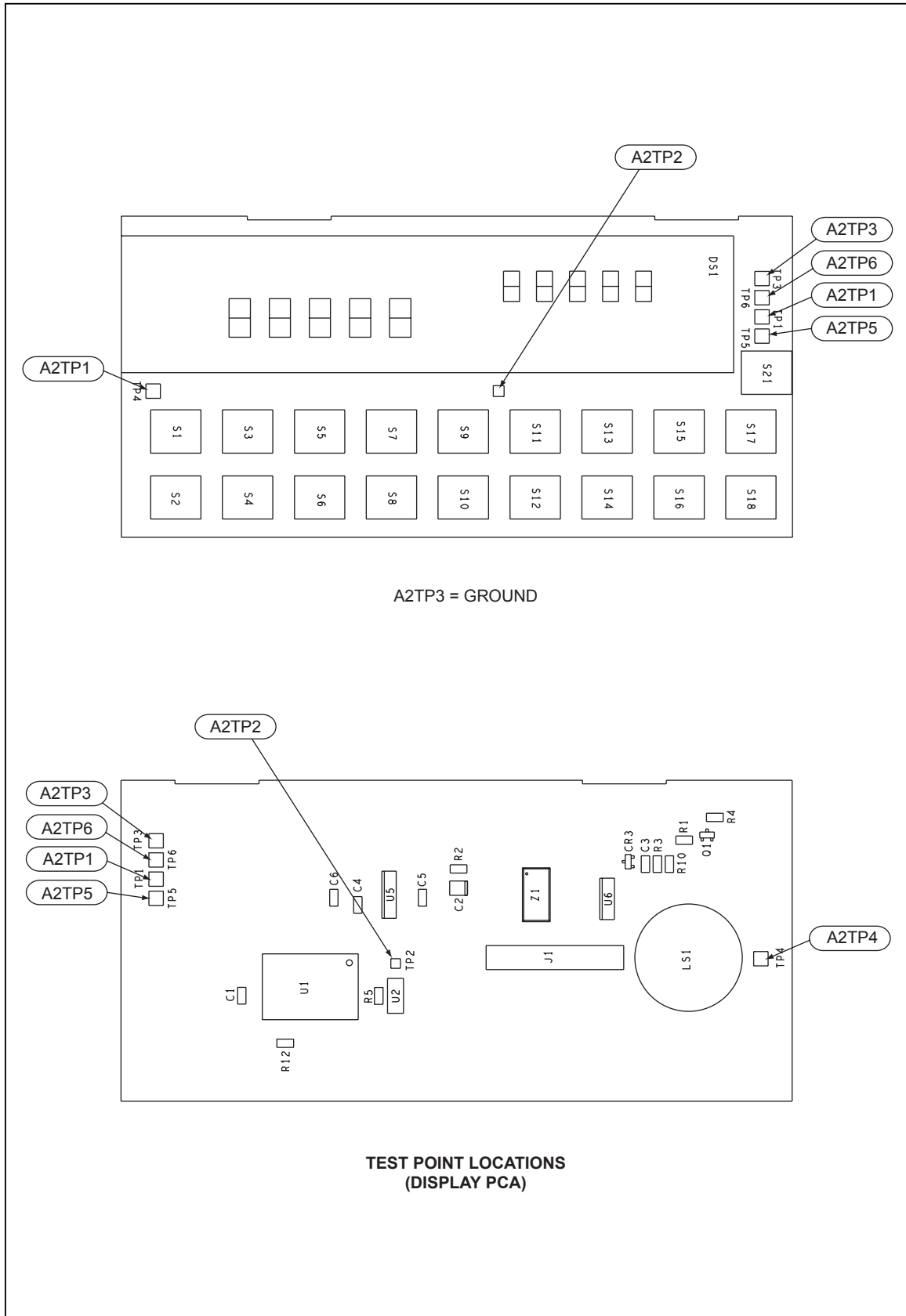

Figure 5-1. Test Point Locator (cont)

qb22c.eps

5-4. General Troubleshooting Procedures

The Fluke 45 allows for some fault isolation using self-diagnostic routines and descriptive error codes. However, these features are somewhat limited and do not provide in-depth troubleshooting tools.

The Fluke 45 incorporates a semi-modular design; determining modules not related to a problem constitutes the first step in the troubleshooting process. Disconnect the Battery Option cable at the Main PCA. Disconnect the IEEE-488 Interface Option at P2 and P3 on the IEEE-488 Interface PCA. If either of these assemblies is causing the meter failure, refer to troubleshooting information in Chapters 7 and 8 (7 for the Battery Pack Option, 8 for the IEEE-488 Interface Option.)

Measuring the power supplies helps to isolate a problem further. Refer to Table 5-2 and Figure 5-1 for test point identification and readings. If power supply loading is suspected, disconnect the Display PCA at J4 on the Main PCA. If this action solves the loading problem, proceed to Display Assembly Troubleshooting elsewhere in this chapter. Otherwise, refer to Power Supply Troubleshooting.

If the power supplies appear good, check the E clock signal to determine whether the Main PCA or the Display PCA is causing the problem. A correct display depends on the E clock signal. Missing segments, intensified digits, a strobing display, or a blank display can be caused by a faulty E clock.

Use an oscilloscope to check for the E clock at microcomputer A1U6, pin 68. Look for a 921.6 kHz square wave that transitions from 0 to 5 V dc (VCC).

- If this signal is present, the problem is probably on the Display PCA. Refer to Display Assembly Troubleshooting elsewhere in this chapter.
- If the E clock is something other than a 921.6 kHz square wave, isolate the digital chapter of the Main PCA by disconnecting the Display PCA at J4. Then check the E clock again, and refer to Digital Troubleshooting elsewhere in this chapter for further problem isolation.

5-5. Power Supply Troubleshooting

5-6. Raw DC Supply

With the meter off (but connected to line power), check for approximately 16 V dc (at 120 V ac line voltage) between the ground test point and the cathode of either A1CR2 or A1CR3. If necessary, check for transformer secondary voltage of approximately 24 V ac.

With the meter on, check for 19 V dc from A1U11, pin 8 to the ground test point. This voltage is approximately 5 volts greater than the raw supply voltage when the switching supply is operating properly. The controller IC, A1U11, starts operating when its supply voltage is approximately 2.5 V dc.

Table 5-2. Power Supplies

Supply Name	Measure		Supply Range
	From:	To:	
Main PCA (In-Guard Circuits)			
VDD	A1TP10	COM, A1R2, or A1R3*	4.95 to 5.45 V dc
VSS *	A1TP12	COM, A1R2, or A1R3	-4.95 to -5.45 V dc
+VAC	+VAC	COM, A1R2, or A1R3*	4.7 to 5.35 V
-VAC	-VAC	COM, A1R2, or A1R3*	-4.7 to -5.35 V
Main PCA (Out-Guard Circuits)			
VCC	A1TP18	A1TP17	4.85 to 5.35 V dc
VEE	A1TP16	A1TP17	-5.0 to -6.0 V dc
VLOAD	A1TP15	A1TP17	-28.5 to -32.0 V dc
Display PCA (Out-Guard Circuits)			
VCC	A2U1-21	A2TP3 or A2U1-42	4.85 to 5.35 V dc
VEE	A2U1-4	A2TP3 or A2U1-42	-5.0 to -6.0 V dc
VLOAD	A2U1-5	A2TP3 or A2U1-42	-28.5 to -32.0 V
* These points are at 'Common.' 'Ground' is also used in the meter, but in relation to Out-Guard circuits only. For example, the A2 Display PCA uses 'Ground'.			

5-7. 5-Volt Switching Supply

Use an oscilloscope to troubleshoot the 5-volt switching supply. Check the waveform at either A1U11, pin 6 (switch transistor collector) or A1T1, pin 2 to determine the loading on the 5-volt switching supply.

- Normal load:

The waveform is a square wave with a period of approximately 20 to 25 μ s and an ON (voltage is low) duty ratio of about 0.35 when the line voltage is about 120 V ac. The amplitude is usually about 15 V p-p. The positive-going edge of the waveform will be "fuzzy" as the duty ratio is varying to compensate for the ripple of the raw supply and the pulsing load due to the switching of the inverter. See Figure 5-2.

- Very Light or No Load:

The OFF interval (voltage is high) part of the waveform will have a damped ringing sine wave of 2 to 10 cycles.

- Heavy Load or Shorted:

The waveform is a square wave with a very low ON duty ratio (approximately 0.1.)

If no square wave signal is present, the functioning of the oscillator can be checked by looking at the waveform at A1U11, pin 3. Use the oscilloscope with ac coupling to make this measurement. This waveform should be a sawtooth signal with an amplitude of 0.5 V p-p and a period of approximately 20 to 25 μ s.

The output current of the 5-volt switching supply can be determined by measuring the voltage across the current limit current sense resistors (A1R47, A1R48, A1R49). The current shunt is approximately 0.167 ohms. With line voltage at 120 V ac, typical voltages across the current sense resistors are as follows:

- Meter without options: 42 mV
- Meter with IEEE-488 Interface Option: 72 mV

- Meter with Battery Option
Line Operation: 54 mV
Battery Operation: 43 mV
- Meter with IEEE-488 Interface and Battery Options
Line Operation: 85 mV
Battery Operation: 43 mV

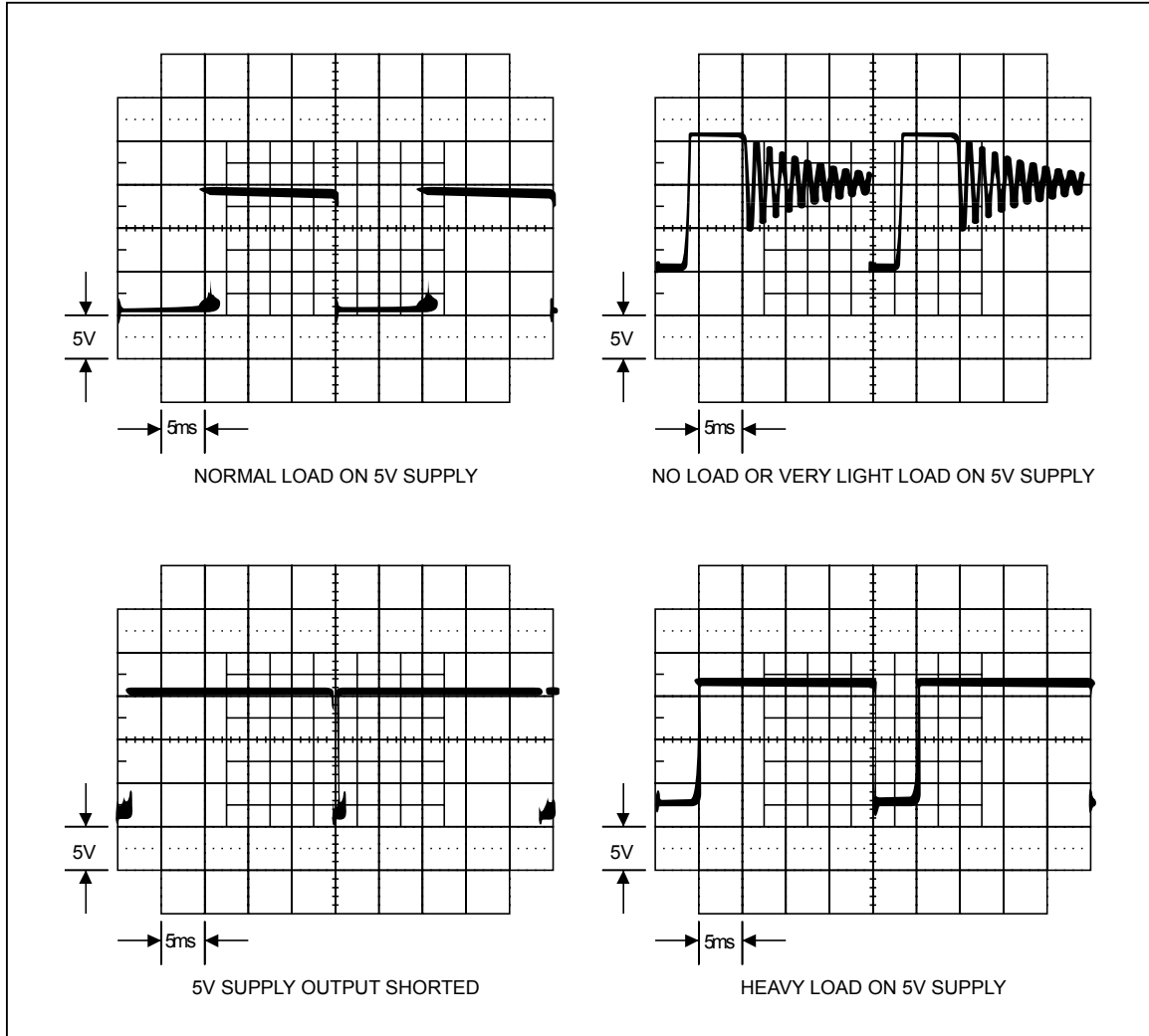

qb23f.eps

Figure 5-2. Volt Switching Supply

5-8. Inverter

Use an oscilloscope to troubleshoot the inverter. Check for a 9.6 V p-p signal (with a period of approximately 30 to 40 μ s) across the primary winding of the inverter transformer (A1T2). If this signal is measured with reference to ground, the amplitude of the square wave should be approximately 4.8 V p-p.

Note

When making voltage measurements in the inverter circuit, remember that there are two separate grounds. The out-guard ground is the 'GRD' test point, and the in-guard ground or common is the 'common' test point.

The normal input current to the inverter supply is about 210 mA, or 1.05 V across A1R46.

5-9. Analog Troubleshooting

Analog circuit problems are evidenced by Error 8 or Error 9 in the display. These errors signify either that the Main Processor (A1U6) is not communicating with the in-guard circuitry or that the Analog Measurement Processor (A1U1) is not functioning correctly.

First, check the in-guard power supplies referenced to common:

Power	Supply	Testpoint Range
VDD	A1TP10	4.95 to 5.45 V dc
VSS	A1TP12	-4.95 to -5.45 V dc
+VAC	+VAC	+4.7 to +5.35
-VAC	-VAC	-4.7 to -5.35

Check the out-guard to in-guard communication for activity whenever a front panel button is pressed. If necessary, press a button repeatedly while looking for the following communication activity:

A1TP8 = GROUND to VCC pulses

A1TP4 = COMMON to VDD pulses

Check the in-guard to out-guard communication:

A1TP5 = VDD to 0.7 V above COMMON pulses

A1TP7 = GROUND to VCC pulses

Check the crystal oscillator referenced to COMMON:

A1TP3 = a 3.84 MHz sine wave (260 ns period)

Check the integrator waveform referenced to COMMON:

A1U1-45 should be a triangle wave when an input is being measured.

Check the 1.1 V reference:

A1TP2 to A1TP1 = +1.1 V

In general, check that the relays are getting the proper drive signals and that they are in the correct position.

The 10 A current shunt (A1R3) or the mA current shunt (A1R2) can be used as a convenient COMMON test point.

5-10. Uart Test

This test checks both the optoisolators (A1U3 and A1U4) and the Analog Measurement Processor (A1U1) UART circuitry. The Main Processor (A1U6) first sends a break signal (5 V dc, logic high) to A1U1, then waits for a break signal in response from A1U1. Once this occurs, A1U6 commands A1U1 to remove its break signal response.

To initiate the UART test, hold the **(RATE)** button down for three seconds. If the test passes, "PASS" is shown in the secondary display. If the test fails, "FAIL" is shown in the secondary display. The test is run repeatedly, updating the "PASS" or "FAIL" display each time. An oscilloscope can thereby be used to trace the rectangular wave forms across optoisolators A1U3 and A1U4.

To exit the UART Test, turn the meter off, wait three seconds, then turn the meter back on.

5-11. DC Volts Troubleshooting

Put the meter in the 300 mV or 3 V range, and apply an input. Then trace this signal as described in Table 5-3.

5-12. AC Volts Troubleshooting

Apply a signal with the multimeter set for the 300 mV ac range. Then trace this signal as described in Table 5-4.

5-13. Ohms Troubleshooting

Use a meter with high input impedance to measure the open circuit voltage for each ohms range listed below. If a high input impedance meter is not available, the following checks can be made on the 30 k Ω and lower ranges only.

RANGE	VOLTAGE:
300 Ω	3 V
3 k Ω	1.3 V
30 k Ω	1.3 V
300 k Ω	1.3 V
3 M Ω	1.3 V
30 M Ω	3 V
300 M Ω	3 V

With failures with these tests, suspect components are A1R5, A1RT1, A1K2, A1Q1, A1Z1, and A1U1.

Now check the signal path at the following points: W1, A1U1-23 (OVS), A1U1-58 (AFI), and A1U1-56 (AFO). Suspect components for these checks are A1R6, A1R7, A1K1, and A1U1.

Table 5-3. DC Volts Troubleshooting

Checkpoint	Description	Possible Fault
A1U1-23 (OVS)	Input signal	A1W1, A1R6, A1R7, A1K1
A1U1-58 (AFI)	Input signal, active filter input	A1U1
A1U1-56 (AFO)	Input signal, active filter output	A1U1
A/D low path	Check continuity among A1U1-13, RRS, and COMMON.	A1R9, A1K2

Table 5-4. AC Volts Troubleshooting

Checkpoint	Description	Possible Fault
A1Z2-1	Input signal	A1R5, A1R5, A1C1, A1K3
A1U1-2 (ACBO)	Amplified input (input x 2.5)	A1U1, A1R11-A1R14, A1Q2-A1Q8, A1Z2, A1AR1, A1C7, A1R16, A1R17
A1U1-68 (RMSI)	Amplified input	A1U1
A6U1-14	Amplified input	A6U1
A1Z4-2	DC equivalent of amplified input	A6U1
A1U1-61 (RMSF)	DC equivalent of original input	A1Z4, A1R19, A1C10

5-14. Digital Troubleshooting

At power-up, if the display does not light or lights up and fails to report errors or begin operation, use the following troubleshooting procedures.

First check the state of SWR1 (A1U6-21). If this status line is less than 0.8 V, basic processor operation is intact. Examining SWR2 through SWR5 (A1U6-22 through -25, respectively) should indicate how far the software progressed before finding an error. If the state of SWR1 is not less than 0.8 V, the problem may be in the 6303Y Main Processor (A1U6), the ROM or RAM decode circuitry (A1U9), the ROM (A1U8) or RAM (A1U10), or the address/data lines among these parts.

Note

The functions of SWR1 through SWR5 as power-up status lines only persist for 2 to 3 seconds. These functions end when the keyboard scanner begins operation (if it can). Extremely difficult cases may require the use of an oscilloscope triggered on the falling edge of SWR1 to examine the states of SWR2 through SWR5.

To determine the relative health of the 6303Y Main Processor (A1U6), first check for a valid E clock at pin 68. The default for the E clock after reset is a rectangular wave with a period of 1.628 us and a duty cycle of about 67%.

If the processor is able to fetch instructions from the ROM, the software initializes the processor, and the E clock becomes a square wave with a period of 1.085 us. Since this initialization occurs almost immediately with a working meter, the resulting square wave on the E clock line is a good indication that the software has begun to execute.

If the E clock remains a 1.628 us rectangular wave, the SWR2 (A1U6-22) keyboard scan line may be shorted to ground. This condition would cause the Main Processor to HALT after reset. Check whether the 6303Y Main Processor is attempting to access ROM; LIR* (pin 64) should transition for a short period of time after reset. If it does, the 6303Y Main Processor is probably operational, and the problem is external to the processor.

The processor can execute an instruction that stops both itself and the E clock. Therefore, the absence of any activity on pin 68 does not necessarily mean that A1U6 or A1Y2 is bad. If some other failure prevents proper ROM access, the processor may have just "gone to sleep". This can be verified by checking for a rectangular wave occurring at pin 68 for a short time after RESET* transitions high on pin 7. A1U6 and A1Y2 are probably operational if this rectangular wave is present.

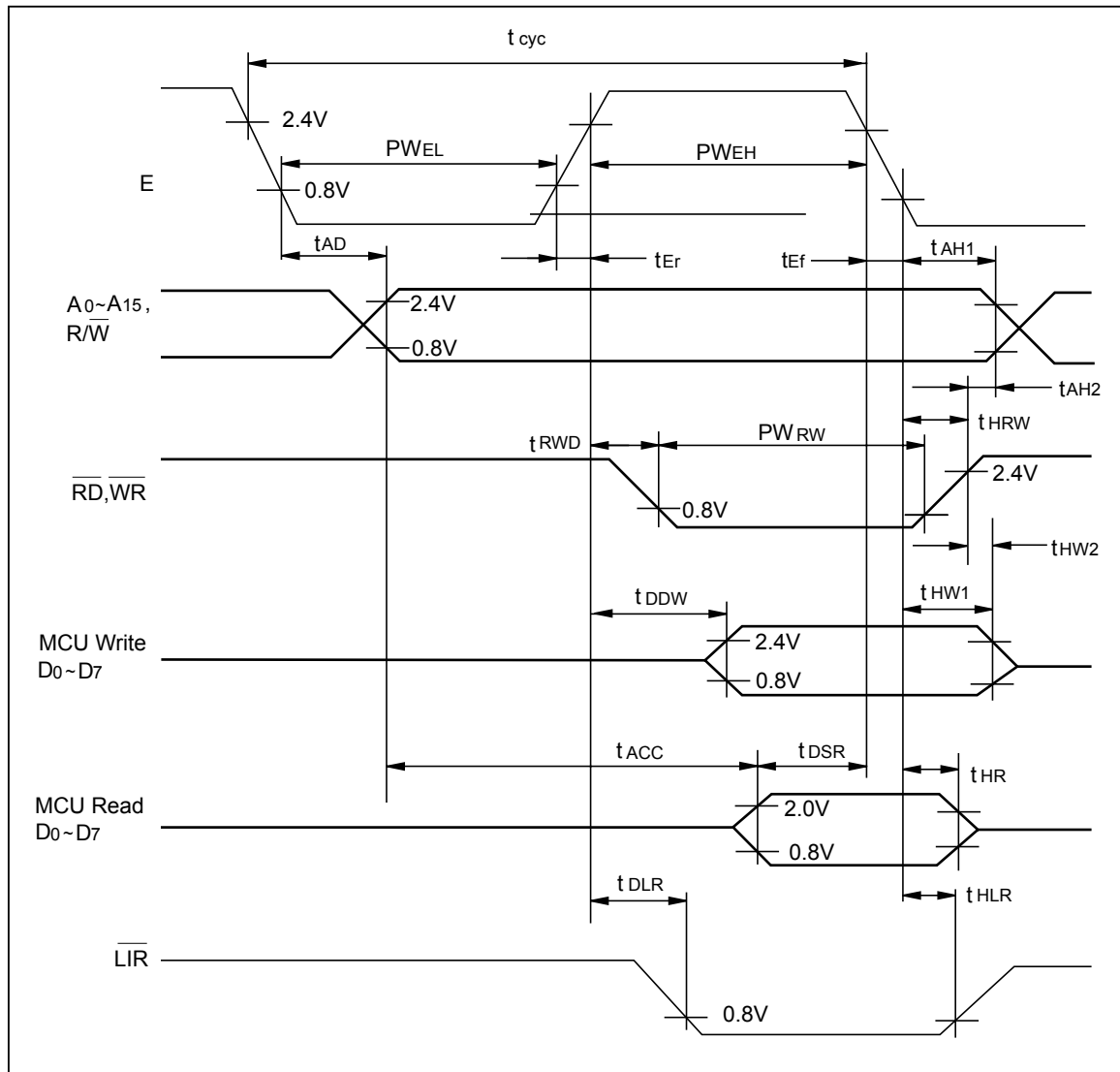

qb24f.eps

Figure 5-3. Main Processor Timing

To check the ROM decode circuitry, verify that A1U9-6 is transitioning low and that these transitions correspond roughly to the low-going transitions of LIR*. Pin 6 must be low when LIR* is low; see Figure 5-3. Verify that this signal also appears at the ROM Chip Enable, A1U8-20. If the ROM Chip Enable is present, the problem is with the ROM itself or there is a fault in the address/data lines among the 6303Y Main Processor, ROM, RAM, and IEEE option connector.

If SWR1 (A1U6-21) and SWR2 (A1U6-22) transition low, but SWR3 (A1U6-23) remains high, the problem is with the RAM decode circuitry (A1U9), the external RAM (A1U10), or the address/data/control lines between the RAM and the 6303Y Main Processor.

To check the RAM decode circuitry, verify that A1U9-8 is transitioning low and that these transitions correspond approximately to the low-going transitions of WR* (A1U6-66). It may be necessary to continually reset (power on) the meter to check these lines, since the activity probably halts quickly when the meter software goes awry. Verify that the signal on A1U9-8 also appears at the RAM Chip Enable, A1U10-20. If the RAM

Chip Enable is present, the problem is with either the RAM itself or the address, data, RD*, or WR* lines between the 6303Y Main Processor and the external RAM.

Figure 5-3 shows the timing relationships of the 6303Y Main Processor lines LIR* and WR* to the system clock (E) and the address lines A0..A15. The ROM and RAM Chip Enables correspond to the active (low) region shown for the address lines.

5-15. Display Assembly Troubleshooting

The following discussion is helpful if it has been determined that the Display Assembly is faulty. This initial determination may not be arrived at easily, since an improperly operating display may be the result of a hardware or software problem that is not a direct functional part of the Display Assembly. Consult the General Troubleshooting Procedures found earlier in this chapter for procedures to isolate the fault to the Display Assembly. Use the following discussion of display software operation when troubleshooting problems within a known faulty Display Assembly. A Display Extender Cable is available (PN 867952) for use during troubleshooting.

Figure 5-4 shows the timing of communications between the main processor and the display controller.

The Display Controller reads the DTEST* and LTE* inputs to determine how to initialize the display memory. DTEST* and LTE* default to logic 1 and logic 0, respectively, to cause all display segments to be initialized to "on". DTEST* is connected to test points A2TP4, and LTE* is connected to A2TP5. Either test point can be jumpered to VCC (A2TP6) or GND (A2TP3) to select other display initialization patterns. Display Test Patterns #1 and #2 are a mixture of "on" and "off" segments with a recognizable pattern to aid in troubleshooting problems involving individual display segments. When either of the special display patterns is selected, the beeper is also sounded for testing without interaction with the main processor. Table 5-5 indicates the display initialization possibilities. Figures 5-5 and 5-6 show grid and anode assignments for primary and secondary displays, respectively.

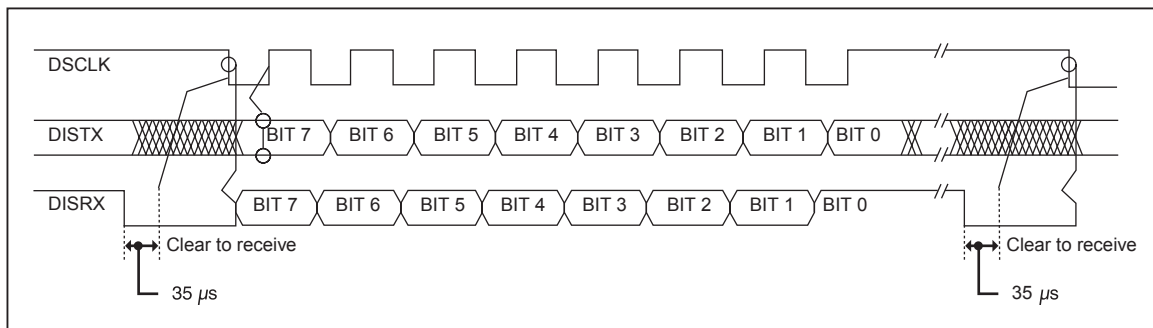
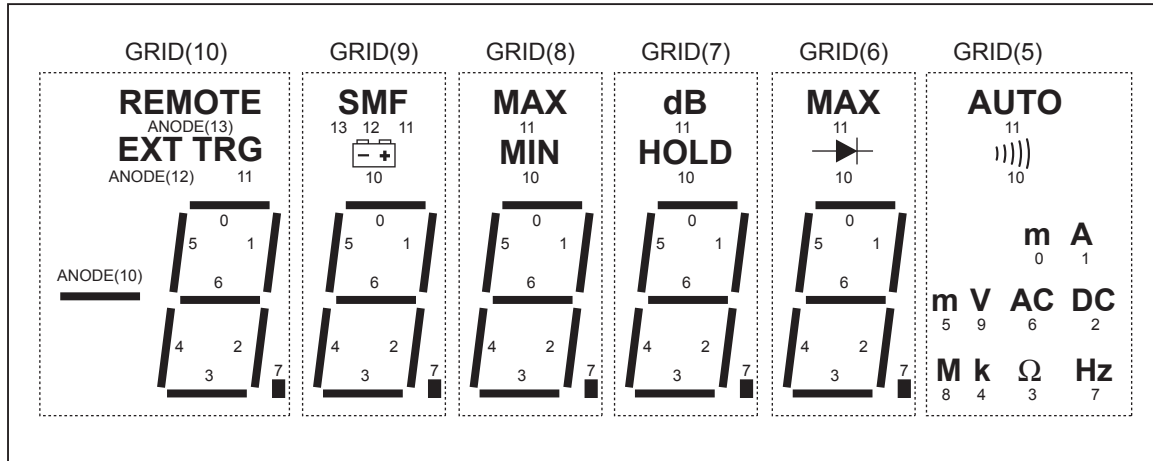

Figure 5-4. Display Controller to Microprocessor Signals

qb09.eps

Table 5-5. Display Initialization

A2TP4 Dtest*	A2TP5 LTE*	Power-Up Display Initialization
1	1	All Segments OFF
1	0	All Segments ON (default)
0	1	Display Test Pattern #1
0	0	Display Test Pattern #2



qb26f.eps

Figure 5-5. Primary Display

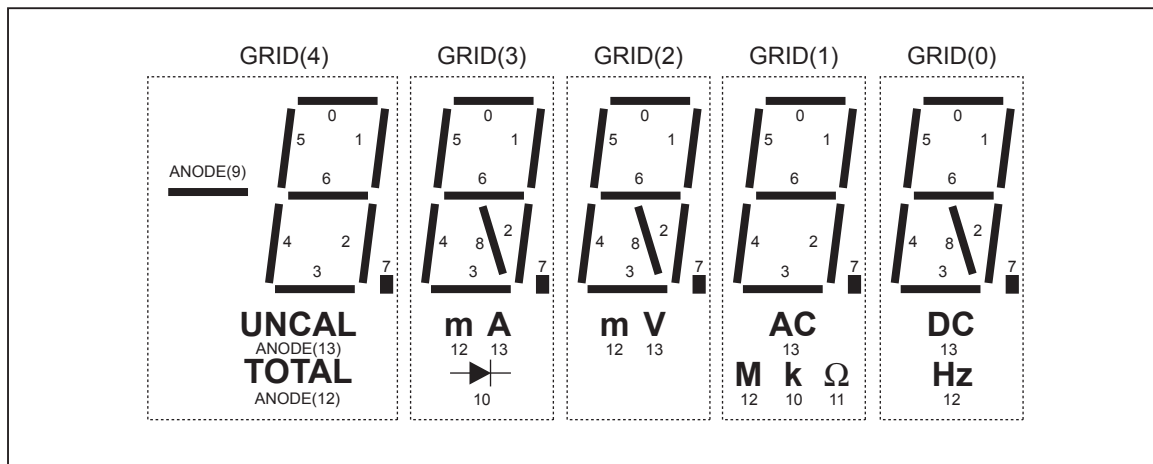

qb27f.eps

Figure 5-6. Secondary Display

When a Fluke 45 display is initially powered up, all display segments should come on automatically. If this display does not appear, proceed with the following steps:

Note

If the display is operational but has problems with front-panel button presses, proceed directly to step 9.

1. Check the three power supplies with respect to GND (A2TP3 or A2U1-42) on the Display Assembly.
 - VCC (A2U1-6) 4.85 to 5.35 V dc
 - VEE (A2U1-19)-5.0 to -6.0 V dc
 - VLOAD (A2U1-18)-28.5 to -32.0 V dc
2. Check the filament drive signals FIL1 and FIL2; these connect to the last two pins on each end of A2DS1. These signals should be 5.0 V ac centered on a -25 V dc level. FIL1 and FIL2 should be 180 degrees out of phase. If the dc bias of the filament signals is not at about -25 V dc, the display segments that should be "off" will show a shadowing (or speckling) effect.

Note

It may be necessary to disable the watchdog reset by jumpering A2TP1 (A1U5-3, A1U5-11) to GND (A2TP3) to verify the following items.

3. Check the clock signal at A2TP2. This signal should be 4.19 MHz (.238 μ s per cycle).

If the signal is not 4.19 MHz, the ceramic resonator, U2 is probably defective.
4. Check the state of the RESET signal (A2U1-1). This signal should be low once the reset time is completed (after power-up).
5. Verify that the DISRX signal (A2U1-39) goes low after RESET (A2U1-1) goes low. If this sequence does not occur, communication to the Main Processor is held off with the DISRX signal high. If DISRX stays high but is not shorted to VCC, A2U1 must be faulty.
6. Verify activity for both the DISTX and DSCLK signals. These signals are driven by the Main Processor and must be transitioning for the Display Controller to receive commands from the Main Processor.
7. If all segments of a particular digit do not turn on at power-up, the grid drive from A2U1 may not be connected properly to A2DS1. Grids are numbered from 0 to 10 (left to right as the display is viewed). For a digit to be enabled, the respective grid drive signals (GRID(0:10)) must be at approximately VCC (4.85 to 5.35 V dc.) For a digit to be disabled, the drive must be at VLOAD (-28.5 to -32.0 V dc.)
8. If a segment under each of several (or all) grids fails to be turned on (or off) properly, one of the anode drive signals may not be connected properly from A2U1 to A2DS1. When an anode signal is at VCC, and a grid signal is at VCC, then the corresponding segment on the display is illuminated.
9. If the Main Processor has difficulty recognizing front-panel button presses, the switch scanning signals (SWR1 through SWR6, A1U6-21 through -26, respectively) should be checked. When no switch contacts are being closed, the switch scanning lines should have about 20 k Ω of resistance between each other (through two 10 k Ω pullup resistors to VCC). None of the switch scanning lines should be shorted directly to GND at any time, unless one of the switches is closed.

5-16. Calibration Failures

5-17. Introduction

Calibration processes for both front panel and computer interface operation are described in Chapter 4 of this manual. Generally, a calibration failure is noted with an error beep

and a displayed 'Error' at the front panel and a device dependent error over the computer interface. These indications occur if the input varies from what the meter expects to see by more than $\pm 15\%$. After one second, the meter reverts to normal operation in calibration mode.

Before suspecting a fault with the Fluke 45, verify that the calibration is being conducted properly.

- Check the connections between the source and the meter. Are all the connections in place.
- Check the output of the calibration source. Does it equal the value called for by this calibration step?
- Check the calibration source. Is it in operate mode? Has it reverted to standby?

If the calibration setup is correct, a faulty component within the Fluke 45 may be causing the failure. Each measurement function depends on a combination of components in and around the Analog Measurement Processor (A1U1). Basic dc measurements depend on the zener reference (A1VR1), reference divider network (A1Z3), and integrate resistors (A1Z3). Resistance measurements and dc measurements above three volts additionally depend on the resistors in the dc divider network (A1Z1). AC measurements depend on the ac divider network (A1Z2), ac buffer (A1AR1), and rms converter (A1A1), as well as the basic dc measurement components.

Note

The Fluke 45 utilizes three measurement rates: slow, medium, and fast. Two sets of measurement ranges are used: one for the medium and fast rates and one for the slow rate. Whenever the meter is powered-up or put in calibration mode, the medium rate is selected. During calibration, the slow rate is selected automatically as required by the calibration step.

5-18. Calibration-Related Components

Measurement function calibration depends on various combinations of components in and around the Analog Measurement Processor. The major components are:

- Rms Converter A1A1
- AC Buffer A1AR1
- Shunt Resistors A1R2, A1R3
- Zener Reference A1VR1
- Divider Network (DC/Ohms) A1Z1
- Integrate Resistors, Reference Divider A1Z3
- AC Divider Network A1Z2
- Rms Converter Network A1Z4

Calibration of the Fluke 45 utilizes a building block approach; individual components are calibrated separately and the appropriate calibration building blocks are assembled later for correction of any particular measurement function, range, and rate. Calibration steps are grouped by function, with dc volts being first.

Therefore, the calibration constants are partitioned to allow for some independence in the correction of the various measurement functions. For example, if the zener reference and divider needed replacing, it would be necessary to recalibrate dc volts only; ac volts would not be affected. Table 5-6 identifies components that are unique to each

calibration step. Table 5-7 provides a different approach, relating components that are common to a group of calibration steps.

5-19. Calibration Interrelationships

If you suspect calibration errors, but the meter does not exhibit the symptoms mentioned above, verify that you are observing the following calibration rules:

- Stored dc volts calibration constants influence constants for several other functions. If dc volts is recalibrated, these other functions must be recalibrated. This interrelationship is explained in Table 5-8.
- Independent calibration of any function except dc volts results in the storage of correcting calibration constants for that function only.
- Once calibration is begun, all steps for that function must be completed before the calibration constants are stored. If all steps are not completed and the procedure is terminated, only calibration constants for previously completed functions are stored.

5-20. Retrieving Calibration Constants

If a calibration error is suspected, the stored constant can be retrieved and verified over the computer interface. This information can be specified by the number of the constant. Table 5-9 lists the calibration constant numbers. Use the following format:

CALCONST? xx (where xx denotes the calibration constant number)

Except for constants 9, 11, 21, and 32, the response format is:

±1.XXXXXXor ±0.XXXXXXX

5-21. Replacing the EEROM A1U5

The EEROM provides non-volatile storage for the serial number of the meter, meter configuration and calibration information. If the EEROM is replaced during repair, the new EEROM should be programmed with the 7-digit serial number, found on the rear panel of the meter. Use the following command to program the serial number into the EEROM:

SERIAL XXXXXXXX (xxxxxxx denotes the 7-digit serial number. Note: once entered, the serial number cannot be changed.)

Table 5-6. Calibration Steps and Related Components

Step	Range	Input	Related Components
VDC			
1	100 mV	0.0000 V	A1VR1, A1Z3
2	100 mV	0.0900 V	A1VR1, A1Z3
3	100 mV	-0.0900 V	A1VR1, A1Z3
4	1000 mV	0.9000 V	A1VR1
5	100 mV	0.0900 V	A1VR1, A1Z3
6	100 mV	0.2900 V	A1VR1, A1Z3
7	300 mV	2.9000 V	A1VR1, A1Z3
8	3 V	29.000 V	A1VR1, A1Z1, A1Z3
9	30 V	290.00 V	A1VR1, A1Z1, A1Z3
10	300 V 1000 V	1000.0 V	A1VR1, A1Z1, A1Z3
VAC			
11	300 mV	0.0290 V	A1A1 A1VR1, A1Z2, A1Z3, A1Z4
12	300 mV	0.2900 V	A1A1 A1VR1, A1Z2, A1Z3, A1Z4
13	3 V	0.2900 V	A1A1 A1VR1, A1Z2, A1Z3, A1Z4
14	3 V	2.9000 V	A1A1 A1VR1, A1Z2, A1Z3, A1Z4
15	30 V	29.000 V	A1A1 A1VR1, A1Z2, A1Z3, A1Z4
16	300 V	290.00 V	A1A1 A1Z1, A1Z2, A1Z3, A1Z4
17	750 V	750.00 V	A1A1 A1Z1, A1Z2, A1Z3, A1Z4
DC mA			
18	30 mA	29.000 mA	A1R2, A1VR1, A1Z3, A1F1
19	100 mA	100.00 mA	A1R2, A1VR1, A1Z3, A1F1
AC mA			
20	30 mA	29.000 mA	A1A1, A1R2, A1VR1, A1Z2, A1Z3, A1Z4, A1F1
21	100 mA	100.00 mA	A1A1, A1R2, A1VR1, A1Z2, A1Z3, A1Z4, A1F1
DC A			
22	10 A	10.000 A	A1R3, A1VR1, A1Z3, A1F2
AC A			
23	10 A	2.0000 A	A1A1, A1R3, A1Z4, A1F2
24	10 A	10.000 A	A1A1, A1R3, A1VR1, A1Z3, A1Z4, A1F2
Ohms			
25	300 Ω	190.00 Ω	A1Z1, A1Z3
26	3 kΩ	1.9000 kΩ	A1Z1, A1Z3
27	30 kΩ	19.000 kΩ	A1Z1, A1Z3
28	300 kΩ	190.00 kΩ	A1Z1, A1Z3
29	3 MΩ	1.9000 MΩ	A1Z1, A1Z3
Continuity/Hysteresis Threshold			
30		0.000 mV	A1U1
31		20.00 mV	A1U1
Frequency			
32		2.000 V p-p 10 kHz	A1Y1

Table 5-7. Components Unique to Calibration Steps

Cal Step	Related Component (Main PCA)										
	A1A1	A1AR 1	A1R2	A1R3	A1U1	A1VR1	A1Y1	A1Z1	A1Z2	A1Z3	A1Z4
VDC											
1					x						
2						x		x			
3						x		x			
4						x		x			
5						x		x			
6						x		x			
7						x		x			
8						x		x		x	
9						x		x		x	
10						x		x		x	
VAC											
11	x					x			x	x	x
12	x					x			x	x	x
13	x					x			x	x	x
14	x					x			x	x	x
15	x					x			x	x	x
16	x					x			x	x	x
17	x					x			x	x	x
DC mA											
18			x			x				x	
19			x			x				x	
AC mA											
20	x		x			x			x	x	x
21	x		x			x			x	x	x
DC A											
22				x		x				x	
AC A											
23	x			x		x				x	x
24	x			x		x				x	x
OHMS											
25								x		x	
26								x		x	
27								x		x	
28								x		x	
29								x		x	
Continuity/Hysteresis Threshold											
30					x						
31					x						
Frequency											
32								x			

Table 5-8. Calibration Hierarchy

Calibration Type	Prior Calibration Required
DC Volts	none
AC Volts	DC Volts
DC Amps	DC Volts
AC Amps	DC Volts
Ohms	DC Volts
Continuity/Hysteresis Threshold	none
Frequency	Continuity/Hysteresis Threshold

Table 5-9. Calibration Constants

Calconst?	Valid Range	Description
1	0.97025 to 1.03775	VDC, range 1
2	0.97025 to 1.03775	VDC, range 2
3	0.97267 to 1.04554	VDC, range 3
4	0.96782 to 1.04035	VDC, range 4
5	0.96792 to 1.04045	VDC, range 5
6	0.9975 to 1.0025	100 mV gain
7	0.9975 to 1.0025	320 mV gain
8	0.9975 to 1.0025	3.2 V gain
9	-100 to 100	VAC offset, range 1
10	0.9725 to 1.0275	VAC, range 1
11	-100 to 100	VAC offset, ranges 2 through 4
12	0.9725 to 1.0275	VAC, range 2
13	0.9725 to 1.0275	VAC, range 3
14	0.9725 to 1.0275	VAC, range 4
15	0.9725 to 1.0275	VAC, range 5
16	0.9500 to 1.0500	ADC, range 1
17	0.9500 to 1.0500	ADC, range 2
18	0.9500 to 1.0500	ADC, range 3
19	0.9225 to 1.0775	AAC, range 1
20	0.9225 to 1.0775	AAC, range 2
21	-100 to 100	AAC offset, range 3
22	0.9225 to 1.0775	AAC, range 3
23	0.9990 to 1.0090	OHMS, range 1
24	1.0000 to 1.0100	OHMS, range 2
25	1.0040 to 1.0140	OHMS, range 3
26	0.9990 to 1.0090	OHMS, range 4
27	0.9990 to 1.0090	OHMS, range 5
28	0.9990 to 1.0090	OHMS, range 6
29	0.9886 to 1.0035	Slow Siemens
30	0.9910 to 1.0010	Medium and Fast Siemens
31	0.9999 to 1.0001	Frequency calibration
32	-10.0 to 10.0	Slow offset
33	1.0000 to 1.0006	Slow negative gain

Chapter 6

List of Replaceable Parts

	Title	Page
6-1.	Introduction.....	6-3
6-2.	How to Obtain Parts.....	6-3
6-3.	How to Contact Fluke.....	6-4
6-4.	Manual Status Information	6-4
6-5.	Newer Instruments	6-4
6-6.	Parts	6-4

6-1. Introduction

This chapter contains an illustrated list of replaceable parts for the Fluke 45 Dual Display Multimeter. Parts are listed by assembly; alphabetized by reference designator. Each assembly is accompanied by an illustration showing the location of each part and its reference designator. The parts lists give the following information:

- Reference designator
- An indication if the part is subject to damage by static discharge
- Description
- Fluke stock number
- Total quantity
- Any special notes (i.e., factory-selected part)

Caution

A * symbol indicates a device that may be damaged by static discharge.

6-2. How to Obtain Parts

Electrical components may be ordered directly from the manufacturer by using the manufacturer's part number, or from the Fluke Corporation and its authorized representatives by using the part number under the heading FLUKE STOCK NO.

Parts price information is available from the Fluke Corporation or its representatives. Prices are also available in a Fluke Replacement Parts Catalog which is available on request.

In the event that the part ordered has been replaced by a new or improved part, the replacement will be accompanied by an explanatory note and installation instructions, if necessary.

To ensure prompt delivery of the correct part, include the following information when you place an order:

- Instrument model and serial number
- Part number and revision level of the pca containing the part.
- Reference designator
- Fluke stock number
- Description (as given under the DESCRIPTION heading)
- Quantity

6-3. How to Contact Fluke

To contact Fluke, visit Fluke's web site at www.fluke.com or call one of the following telephone numbers:

USA and Canada: 1-888-99-FLUKE (1-888-993-5853)

Europe: +31 402-675-200

Japan: +81-3-3434-0181

Singapore: +65-738-5655

Anywhere in the world: +1-425-446-5500

6-4. Manual Status Information

The Manual Status Information in Table 6-1 defines the assembly revision levels that are documented in the manual. Revision levels are printed on the component side of each PCA.

Table 6-1. Manual Status Information

Ref or Option No.	Assembly Name	Fluke Part No.	PCA Revision Levels
A1	Main PCA	814137	AB
A1A1	True Rms PCA	848200	H
A2	Display PCA	609179	A
-01	Battery PCA	825885	A
-05	IEEE-488 Interface PCA	814152	B

6-5. Newer Instruments

Changes and improvements made to the instrument are identified by incrementing the revision letter marked on the affected pca. These changes are documented on a manual supplement which, when applicable, is included with the manual.

6-6. Parts

The following pages give detailed listings of Fluke 45 parts.

Note

This instrument may contain a Nickel-Cadmium battery. Do not mix with the solid waste stream. Spent batteries should be disposed of by a qualified recycler or hazardous materials handler. Contact your authorized Fluke service center for recycling information.

Table 6-2. Final Assembly

Reference Designator	Description	Fluke Stock No.	Total Qty	Note
A 1	* MAIN PCA	814137	1	
A 2	* DISPLAY PCA	609179	1	
F 1	FUSE,5X20MM, .500A, 250V, FAST	838151	1	
F 2	FUSE,.406X1.5,FAST,11A,1000V,FAST	943118	1	
F 3, 4	FUSE,5X20MM,0.125A,250V,SLOW	822254	2	
F 5	FUSE,0.44 A, 1000V, FAST	943121	1	
H 1, 2	CONN ACC,D-SUB,FEMALE SCREWLOCK,..250	844704	2	
H 3	NUT,EXT LOCK,STL,6-32,.344OD	152819	1	
H 4-7, 14	SCREW,FHU,P,LOCK,SS,6-32,.250	320093	5	
H 8	SCREW,PH,P,LOCK,STL,6-32,.250	152140	1	
H 9	SCREW,PH,P,THD CUT,STL,4-14,.500	853668	1	
H 10, 11	SCREW,TH,P,SS,4-40,.187	721118	2	
H 12, 13	SCREW,PH,P,LOCK,MAG SS,6-32,.500	853986	2	
H 15, 16	SCREW,FH,P,LOCK,STL,8-32,.375	114116	2	
J 1	PWR PLUG,PANEL,6.3A,250V,3 WIRE	780817	1	
J 2	PWR PLUG PART,FUSE HOLDER	780825	1	
MP 1	PAD TRANSFER,FRONT PANEL (CE)	609427	1	
MP 2	PAD TRANSFER, WINDOW	835496	1	
MP 3	ASSEMBLY, CHASSIS	784793	1	
MP 4	GROMMET,EXTRUDED,POLYETHYLENE,.085	854351	1	
MP 5	DECAL,REAR PANEL (CE)	609419	1	
MP 6	INSULATOR, TRANSFORMER	852413	1	
MP 7	SPACER,SNAP,.180 RND,NYL,.125	844845	1	
MP 8	STANDOFF, FEMALE	874748	1	
MP 9	RECEPTACLE,FUSE	824607	1	
MP 10	ROD,POWER SWITCH	784827	1	
MP 11	SHIELD, TOP	784819	1	
MP 12	SHIELD,BOTTOM	791590	1	
MP 13	CASE, OUTER	784769	1	
MP 14, 15	CASE,FOOT, BLACK	824433	2	
MP 16	BEZEL, REAR	885889	1	
MP 17	MOUNTING PLATE,HANDLE(LEFT)	857248	1	
MP 18	MOUNTING PLATE,HANDLE(RIGHT)	857243	1	
MP 19	HANDLE,PAINTED	848205	1	
MP 20	COVER,IEEE	791616	1	
MP 23	CALIBRATION SEAL	735274	1	
MP 29	TEST LEAD ASSY, TL70A	855820	1	
MP 32	LABEL,ADHES,PAPER,.4.750,3.1875	854104	1	
MP 38	STANDOFF, MALE	874743	1	
MP 40	SCREW, PH, 4-14 312	642931	1	
S 1	SWITCH,PUSHBUTTON,DPDT,PUSH-PUSH	836361	1	
S 2	KEYPAD,ELASTOMERIC	855994	1	
T 3	TRANSF,PWR,35W,90-264VAC,14.6-43VAC	609088	1	
TM 1	FLUKE 45 USER MAN, ENGLISH	855981	1	
TM 2	FLUKE 45 USER MAN, GERMAN/FRENCH	856034	1	
W 1	CABLE ASSY,RS232	848192	1	1
W 2	WIRE ASSY,GROUND	834952	1	
W 4	CABLE ASSY,FLAT,20 COND,MICROMOD,3 IN	831578	1	
W 5	CORD,LINE,5-15/IEC,3-18AWG,SVT,7.5 FT	284174	1	

1. For 250 V order part number 769422.

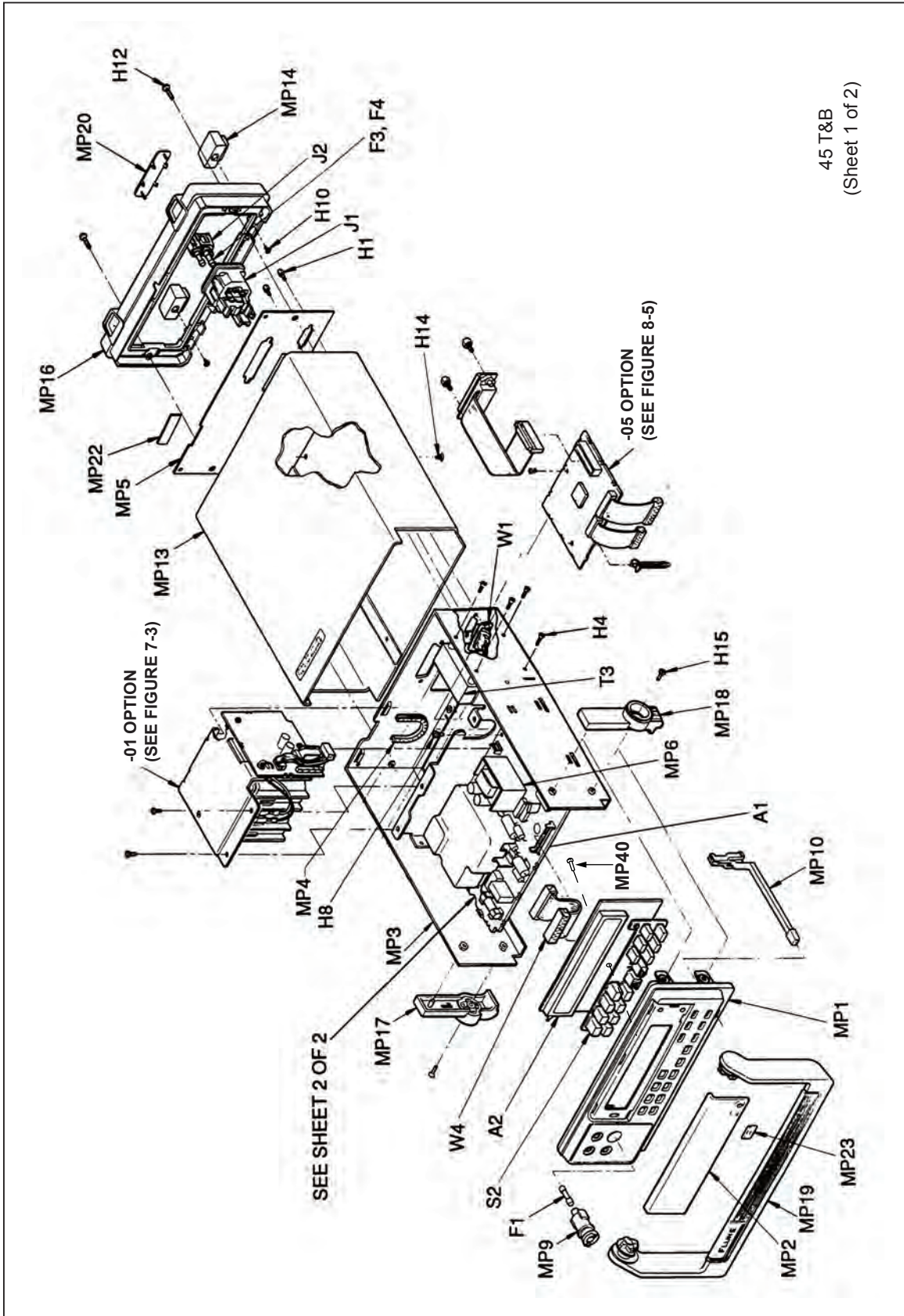

45 T&B
(Sheet 1 of 2)

Figure 6-1. Final Assembly

qb28c.eps

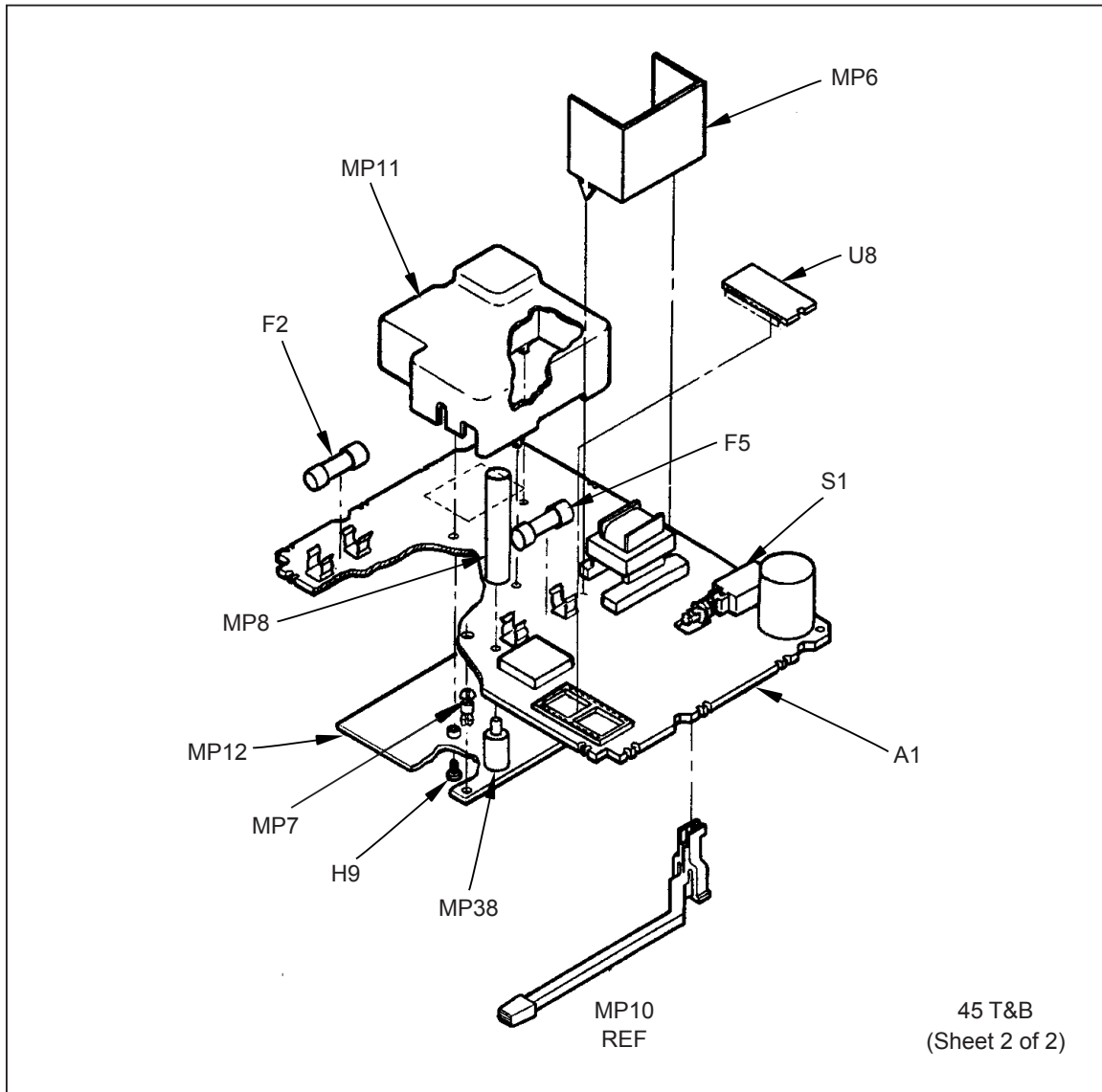

Figure 6-1. Final Assembly (cont)

qb29c.eps

Table 6-3. A1 Main PCA

Reference Designator		Description	Fluke Stock No.	Total Qty	Note
A	1	* TRUE RMS PCA	848200	1	
AR	1	* I C,OP AMP,JFET INPUT,DECOMP,SOIC	837237	1	
C	1	CAP,POLYES,0.1UF,+10%,1000V	837518	1	
C	2	CAP,CER,4.7PF,+0.25pF,50V,C0G,1206	644978	1	
C	3, 5, 9, 19,	CAP,CER,0.1UF,+10%,25V,X7R,1206	747287	10	
C	22-25, 49, 50				
C	17, 18	CAP,CER,4.3PF,+10%,50V,C0G,1206	844738	2	
C	4, 6, 42-44	CAP,AL,470UF,+20%,10V,SOLV PROOF	822387	5	
C	7, 10	CAP,POLYES,0.47UF,+10%,50V	697409	2	
C	8	CAP, 2.2μF	697433	1	
C	12, 13	CAP,POLYPR,0.12UF,+10%,50V	851738	2	
C	14, 16	CAP,POLYPR,0.033UF,+10%,63V	721050	2	
C	15	CAP,TA,2.2UF,+10%,35V	697433	1	
C	20, 21	CAP,CER,15PF,+10%,50V,C0G,1206	837393	2	
C	26, 37- 40	CAP,CER,0.047UF,+20%,50V,X7R,1206	782615	5	
C	27	CAP,AL,4700UF,+20%,35V,SOLV PROOF	821553	1	
C	28	CAP,CER,33PF,+10%,50V,C0G,1206	769240	1	
C	29, 30	CAP,CER,1800PF,+10%,50V,C0G,1206	769786	2	
C	31	CAP,CER,0.047UF,+10%,100V,X7R	844733	1	
C	32, 36, 47	CAP,AL,10UF,+20%,63V,SOLV PROOF	816843	3	
C	33	CAP,AL,220UF,+20%,50V,SOLV PROOF	831867	1	
C	34, 35,41, 46	CAP,AL,47UF,+20%,50V,SOLV PROOF	822403	4	
C	45	CAP,AL,2.2UF,+20%,50V,SOLV PROOF	769687	1	
C	48	CAP,CER,100PF,+10%,50V,C0G,1206	740571	1	
C	51	* CAP,CER,10PF,+10%,50V,C0G,1206	747311	1	
CR	1	* DIODE,SI,BV=70.0V,IO=50MA,DUAL,SOT23	742320	1	
CR	2, 3	* DIODE,SI,100 PIV,1.0 AMP	698555	2	
CR	4, 5, 10-12	* DIODE,SI,BV=75V,IO=250MA,SOT23	830489	5	
CR	6	* DIODE,SI,SCHOTTKY BARRIER,40V,1A	837732	1	
CR	7	DIODE,SI,DUAL,BV=50V,IO=100MA,SOT23	851659	1	
CR	8, 9	DIODE,SI,BV=100,IO=100MA,DUAL,SOT23	821116	2	
J	2, 4	HEADER,1 ROW,.050CTR,20 PIN	831529	2	
J	3	HEADER,1 ROW,.050CTR,14 PIN	831511	1	
J	5	HEADER,1 ROW,.100CTR,4 PIN	631184	1	
J	6	HEADER,1 ROW,.050CTR,10 PIN	831503	1	
J	7	HEADER,1 ROW,.100CTR,3 PIN	845334	1	
K	1- 3	RELAY,ARMATURE,2 FORM C,5VDC,LATCH	603001	3	
MP	1, 2	CONTACT,FUSE 15AMP	844287	2	
MP	3	SPRING,COIL,COMP,SS,.750,.240	836411	1	
MP	5	SOCKET,IC,28 PIN,DUAL WIPE,BEAM TYPE	756353	1	
MP	6	CONTACT, FUSE	659524	1	
MP	7	CONTACT, FUSE	844287	1	

Table 6-3. A1 Main PCA (cont)

Reference Designator		Description	Fluke Stock No.	Total Qty	Note
Q	1	* TRANSISTOR,SI,NPN,SELECT IEBO,SOT-23	821637	1	
Q	2- 8	* TRANSISTOR,SI,N-JFET,SOT-23	820860	7	
Q	9	* TRANSISTOR,SI,NPN,SMALL SIGNAL,SOT-23	742676	1	
Q	10, 12	* TRANSISTOR,SI,PNP,T092	698290	2	
Q	11, 13	* TRANSISTOR,SI,NPN,SELECTED IEBO,TO-92	685404	2	
R	2	RES,WW,10,+5%,5W,30PPM	822064	1	
R	3	RES,WW,.010,+5%,1W,100PPM	820845	1	
R	4, 19, 22	* RES,CERM,200K,+5%,.125W,200PPM,1206	746743	3	
R	5	* RES,WW,3.5k,+5%,5W,20 PPM	107695	1	
R	6, 7	* RES,CERM,100K,+5%,3W	820811	2	
R	8, 16, 17	* RES,CERM,22,+5%,.125W,200PPM,1206	746230	3	
R	9,37,38, 59	* RES,CERM,10K,+5%,.125W,200PPM,1206	746610	4	
R	10	* RES,CERM,100K,+5%,.125W,200PPM,1206	740548	1	
R	11-15, 31,39,45, 55, 56	* RES,CERM,47K,+5%,.125W,200PPM,1206	746685	10	
R	18	* RES,CERM,1M,+5%,.125W,200PPM,1206	746826	1	
R	20, 27, 29	* RES,CERM,200,+5%,.125W,200PPM,1206	746339	3	
R	21	* RES,CERM,215K,+1%,.125W,100PPM,1206	836643	1	
R	23	* RES,CERM,61.9K,+1%,.125W,100PPM,1206	821330	1	
R	24	* RES,CERM,16.9K,+1%,.125W,100PPM,1206	836635	1	
R	25	* RES,CERM,13.3K,+1%,.125W,100PPM,1206	836619	1	
R	26	* RES,CERM,845,+1%,.125W,100PPM,1206	821322	1	
R	28,32	* RES.CHI,CERMET, 1K, ±5%, 1/8W	745992	2	
R	30	* RES,CF,20K,+5%, 0.25W	441477	1	
R	33	* RES,CERM,180,+5%,.125W,200PPM,1206	746321	1	
R	35	RES,CF,220K,+5%,0.25W	851837	1	
R	36	* RES,CF,1M,+5%,0.25W	649970	1	
R	40	* RES,CERM,470K,+5%,.125W,200PPM,1206	746792	1	
R	41	* RES,CERM,10.5K,+1%,.125W,100PPM,1206	851852	1	
R	42	RES,CERM,68.1K,+1%,.125W,100PPM,1206	851845	1	
R	43	RES,CF,10K,+5%,0.25W	697102	1	
R	44	* RES,CERM,5.62K,+1%,.125W,100PPM,1206	837047	1	
R	46- 49	* RES,CF,0.50,+5%,0.25W	830646	4	
R	50, 53	* RES,CERM,432,+1%,.125W,100PPM,1206	811885	2	
R	51, 52	RES,CERM,47,+5%,.125W,200PPM,1206	746263	2	
R	54,60	RES, MOX 22M,+5%,1W, 200 PPM	688887	2	
R	57	RES,CERM,910,+5%,.125W,200PPM,1206	769257	1	
R	58	RES,CF,1K,+5%,0.25W	780585	1	
RT	1	THERMISTOR,DISC,POS,1.1K,+20%,25 C	602995	1	
RV	1, 2, 3	VARISTOR,910V,+10%,1.0 MA	876193	3	

Table 6-3. A1 Main PCA (cont)

Reference Designator		Description	Fluke Stock No.	Total Qty	Note
T	1	INDUCTOR,FXD,DUAL,EE24-25,0.4MH,1.2A	817379	1	
T	2	TRANSF,INV,5VDC,30KHZ,6KV ISO,EE375	817395	1	
U	1	MERCURY/SATURN, ASSY TESTED PLASTIC	776195	1	
U	2	* IC,ARRAY,7 NPN DARLINGTON PAIRS,SOIC	821009	1	
U	3, 4	* ISOLATOR, OPTO, LED, TRANSISTOR	688314	2	
U	5	IC,NMOS,64 X 16 BIT EEPROM	822353	1	
U	6	* IC,CMOS,8-BIT MPU,1 MHZ,256 RAM,PLCC	821298	1	
U	7	* IC,CMOS,RS232 DRIVER/RECEIVER,SOIC	821538	1	
U	8	* EPROM, PROGRAMMED 27C512	857797	1	
U	9	* IC,CMOS,AND-NOR GATES,SOIC	837203	1	
U	10	* IC,CMOS,8K X 8 STATIC RAM,120NS,SOIC	851795	1	
U	11	* IC,VOLT REG,ADJ,SWITCHING REGULATOR	821215	1	
U	12	* IC MICROPROCESSOR RESET CIRCUIT	602920	1	
VR	1	* ZENER,TESTED	857201	1	
VR	2	* ZENER,UNCOMP,6.0V,5%,20MA,0.2W,SOT-	837161	1	
VR	3	* 23	837179	1	
W	1	ZENER,UNCOMP,5.1V,5%,20MA,0.2W,SOT-	834929	1	
W	2	23	834945	1	
W	3	WIRE ASSY,(H)	834911	1	
W	4	WIRE ASSY,FUSE	834937	1	
Y	1	WIRE ASSY,INPUT (10A CUR)	650390	1	
Y	2	WIRE ASSY,(L)	570606	1	
Z	1	CRYSTAL,3.84MHZ,+/-0.05%,HC-18/U	851100	1	
Z	2	CRYSTAL,3.6864MHZ,+/-0.005%,HC-18U	847363	1	
Z	3	RES NET THN F TESTED	833921	1	
Z	4	RES NET THK FILM TESTED	849984	1	
		RES NET THN FILM TESTED			
		RES NET THK FILM TESTED			

1. Fusible resistor. To ensure safety, use exact replacement only.

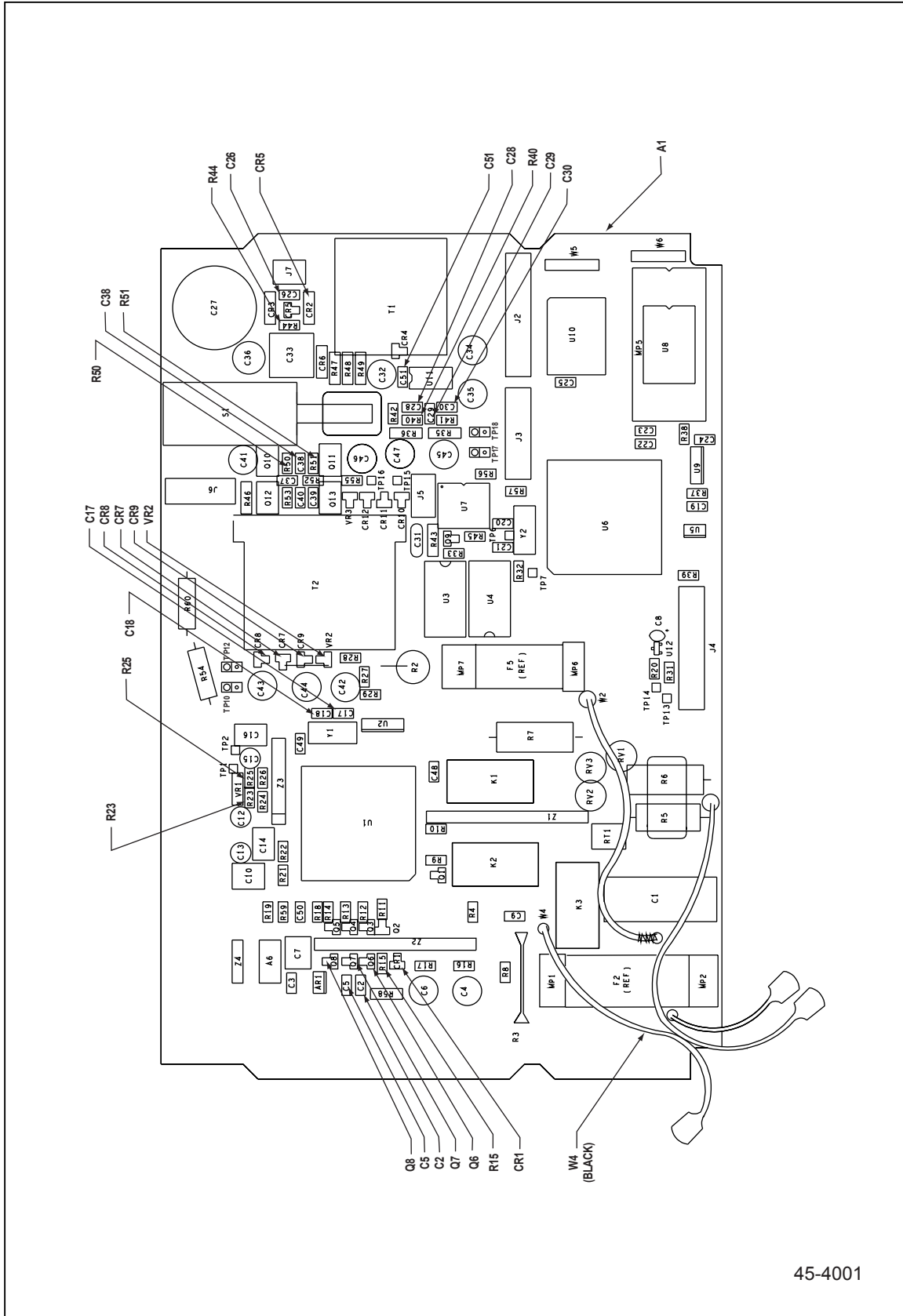
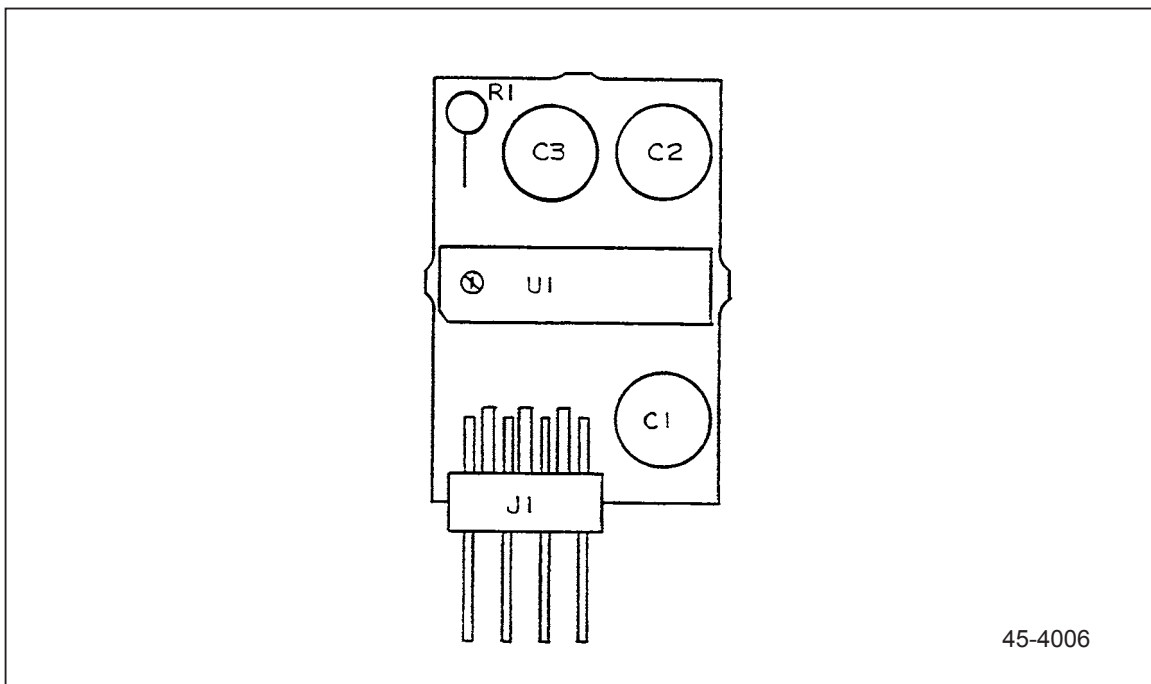

Figure 6-2. A1 Main PCA

qb30c.eps

Table 6-4. A1A1 True Rms PCA

Reference Designator		Description	Fluke Stock No.	Total Qty	Note
C	1	CAP,TA,2.2UF,+/-10%,35V	697433	1	
C	2, 3	CAP,TA,68UF,+/-20%,6.3V	821785	2	
J	1	HEADER,2 ROW,.100CTR,RT ANG,8 PIN	845326	1	
R	1	RES,CF,3.3K,+/-5%,0.25W	854554	1	
U	1	* IC,BPLR,TRUE RMS TO DC CONVERTER	687019	1	



qb31c.eps

Figure 6-3. A1A1 True Rms PCA

Table 6-5. A2 Display PCA

Reference Designator		Description	Fluke Stock No.	Total Qty	Note
C	1, 3- 6	CAP,CER,0.1UF,+/-10%,25V,X7R,1206	747287	5	
C	2	CAP,TA,4.7UF,+/-10%,20V	605433	1	
CR	3	* DIODE,SI,BV=75V,IO=250MA,SOT23	830489	1	
DS	1	TUBE,DISPLAY,VAC FLUOR,7&8-SEG,10CHAR	783530	1	
J	1	HEADER,1 ROW,.050CTR,20 PIN	831529	1	
LS	1	AF TRANSD,PIEZO,22 MM	602490	1	
MP 1	1	FLUKE 45-3021, PWB DISPLAY	609161	1	
Q	1	TRANSISTOR, SI, PNP, 40V, 300 mW, SOT 23	742684	1	
R	1, 10, 12	* RES,CERM,10K,+/-5%,.125W,200PPM,1206	746610	3	
R	2, 5	* RES,CERM,2.2M,+/-5%,.125W,200PPM,1206	811778	2	
R	3	* RES,CERM,1.2M,+/-5%,.125W,200PPM,1206	806240	1	
R	4	* RES, CERM,47K,±5%, .125W,220 PPM,1206	746685	1	
U	1	* IC,CMOS,4-BIT MPU,D75212GF,SMR	688879	1	
U	2	* RESONATOR, SMR, CERM, 4.19 MHz	688317	1	
U	5	* IC,CMOS,DUAL MONOSTB MULTIVBRTR,SOIC	806620	1	
U	6	* IC,CMOS,QUAD 2 IN NAND W/SCHMT,SOIC	837245	1	
Z	1	RES,CERM,SOIC,16 PIN,15 RES,10K,+/-5%	836296	1	

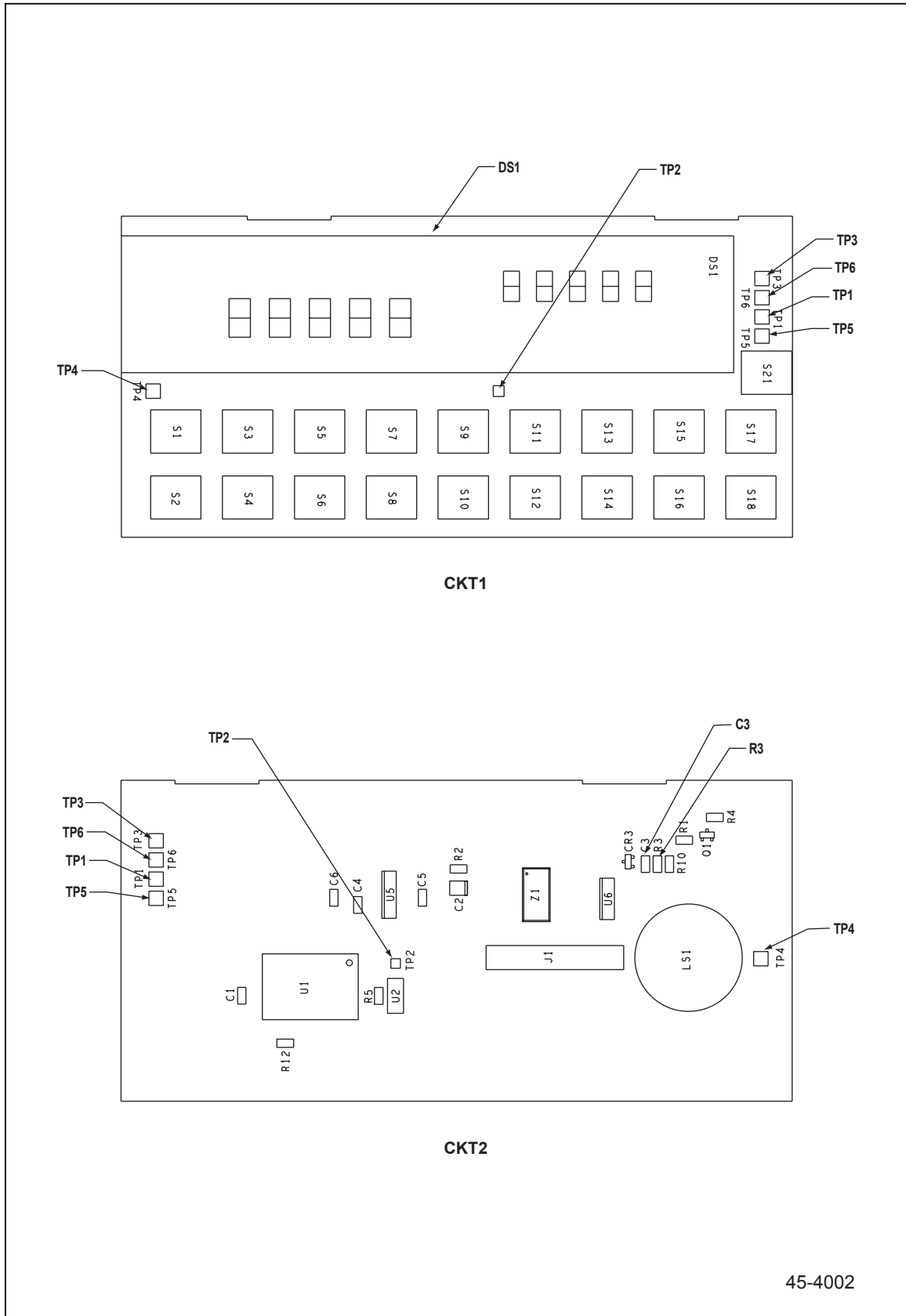

45-4002

qb32f.eps

Figure 6-4. A2 Display PCA

Chapter 7

Option -01 Battery Pack

	Title	Page
7-1.	Introduction.....	7-3
7-2.	Specifications.....	7-3
7-3.	Theory of Operation	7-3
7-4.	Functional Block Description.....	7-3
7-5.	Switching Power Supply	7-5
7-6.	Cycle/Float Charge Rate Switch	7-5
7-7.	Low Battery Indicator Detector	7-5
7-8.	Low Battery Disconnect.....	7-5
7-9.	Constant Voltage Trickle Charger	7-6
7-10.	Other Circuits.....	7-6
7-11.	General Maintenance	7-6
7-12.	Removal.....	7-6
7-13.	Installation	7-7
7-14.	Performance Testing	7-9
7-15.	General Operability	7-9
7-16.	Low Battery Indicator Detector and Low Battery Disconnect Test.	7-10
7-17.	Cycle/Float Charge Rate Switch Test	7-10
7-18.	Calibration	7-12
7-19.	Troubleshooting.....	7-13
7-20.	Additional Tests.....	7-14
7-21.	Schematic Diagram.....	7-14
7-22.	List of Replaceable Parts	7-14

7-1. Introduction

The Fluke 45-01K Battery Kit is a field installable option that may be installed in the meter. The installation of the Battery Kit facilitates portable operation of the meter for typically eight hours.

7-2. Specifications

Specifications for the Battery Kit Option are as follows:

- Type of Cell: Sealed Lead-Acid Rechargeable
- Battery Voltage: 8 Volts Nominal
- Charge Time: 16 Hours Typical w/meter off

7-3. Theory of Operation

7-4. Functional Block Description

The Battery Pack Option PCA consists of the five functional blocks illustrated in Figure 7-1. Each block is described below:

- **Switching Power Supply**
The Switching Power Supply regulates the 7.5 V-to-35 V raw dc input provided by the main circuit board (J1-7). The supply output (9.3 V to 9.8 V, temperature-compensated) is used to charge the 8 V lead-acid battery.
- **Cycle/Float Charge Rate Switch**
The Cycle/Float Charge Rate Switch monitors the charging current required by the battery pack and sets the output voltage accordingly (9.35 V for trickle charging, or 9.8 V for cyclic charging).
- **Low Battery Indicator Detector**
The Low Battery Indicator Detector monitors the battery pack voltage, outputting a logic low to turn on the meter low voltage indicator when the battery pack voltage is below approximately 7.7 V.
- **Low Battery Disconnect**
The Low Battery Disconnect circuit interrupts meter loading on the battery pack when battery pack voltage drops below approximately 7.0 V. This action prevents deep discharge of the batteries.
- **Constant Voltage Trickle Charger.**
When the meter is operated on line power, the charge on the battery pack is maintained with the Constant Voltage Trickle Charger (9.25 V output).

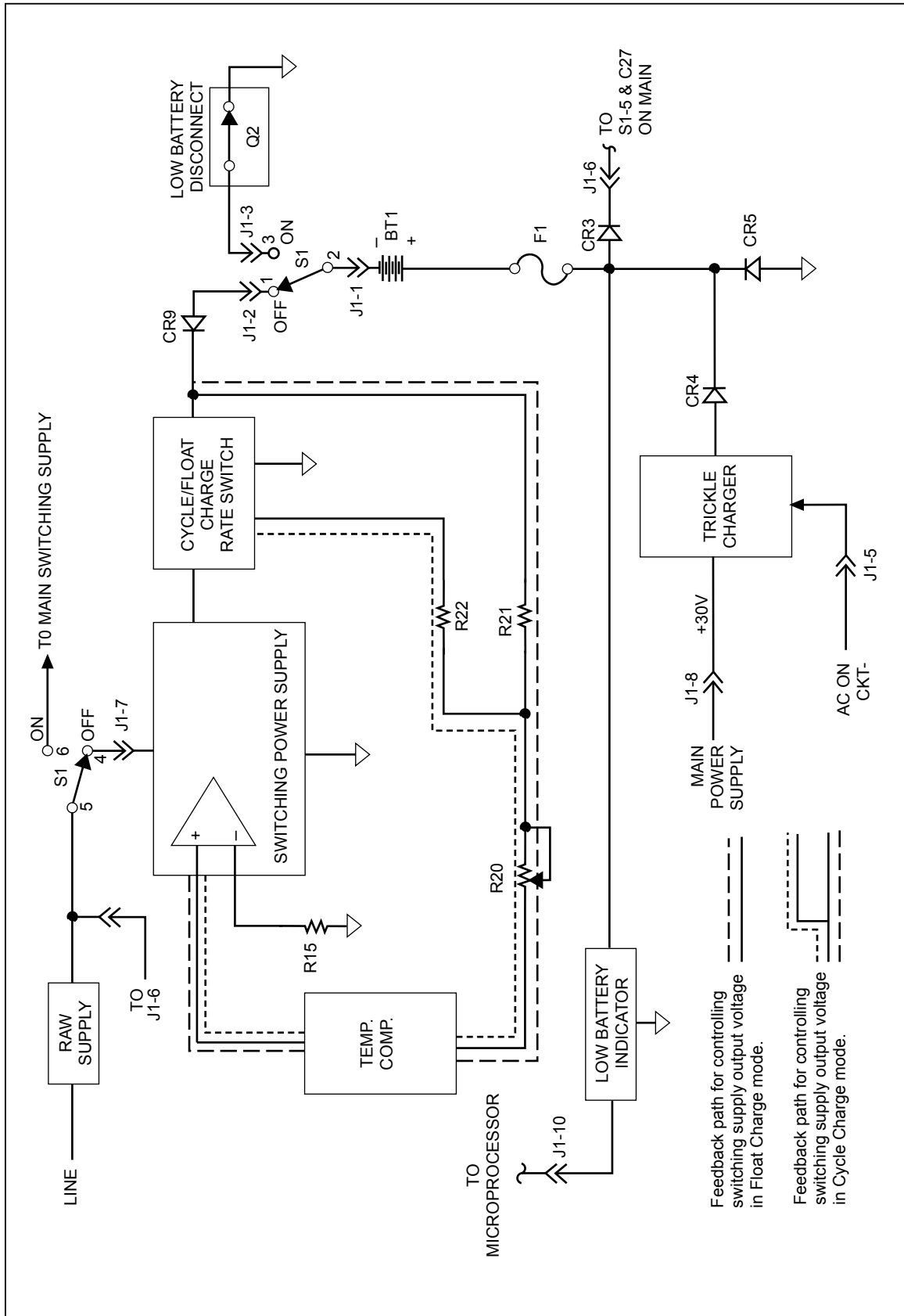

Figure 7-1. Battery Pack Option Functional Block Diagram

qb33f.eps

7-5. *Switching Power Supply*

The switching power supply regulates the output voltage with a pulse-width modulating technique that varies the on time of the FET switch, Q5. The controller chip for this process (U4) contains the required 1 V reference, switching oscillator, regulator comparator, current limit comparators, and output switch. The controller chip is supported by several external components: C7 sets the oscillator frequency; R17, C6, and C8 are required for stability; R15, R21, and R20 set the output voltage level. The variable-width pulse from U4-5 is first level-shifted and clamped by R23, R24, and CR7 and then coupled to the FET switch circuit through inverter U3-2. Hex inverters U3-4, U3-6, and U3-10 are connected in parallel to provide sufficient drive to the FET gate. FET switch Q5 is turned on at the beginning of each square wave drive cycle and turned off at the point necessary to set the desired output voltage.

The current limit is set by the voltage drop across the 0.1-ohm resistance provided by the parallel configuration of five 0.5-ohm resistors (R29, R34, R35, R36, and R37). Current limiting occurs when the voltage drop across the ohm resistance is greater than approximately 100 mV. Current limiting is effected by reducing the duty cycle of the switching transistor, Q5, which in turn reduces the output voltage of the supply.

A bootstrap supply for the driver and coupling/clamp circuits is provided by CR8, R25, C9, C11, VR3. The output level has a negative temperature coefficient to provide the proper charging voltage level for the battery pack over a broad temperature range. This negative coefficient is provided by the Temperature Compensation circuit (Q4, R18, and R19) in the feedback path of the switching power supply.

7-6. *Cycle/Float Charge Rate Switch*

The Cycle/Float Charge Rate Switch monitors the charging current supplied to the battery pack during charge when the meter is de-energized. If the current is 60 mA to 80 mA or higher, the charging voltage is increased to about 9.8 V. This level of current causes a voltage drop across R28 that is sufficient to turn Q6 and Q7 on, connecting one end of R22 to common. The resulting current through R22 modifies feedback to the switching supply, causing the increased output voltage.

As the battery pack charge reaches about 90% of capacity, the charge current at 9.8 volts drops below 60 to 80 mA; Q6 and Q7 turn off, and the charging voltage decreases to 9.35 volts, the trickle charge level for the battery pack. Diode CR10 clamps the voltage across R28 to about 0.8 V maximum.

7-7. *Low Battery Indicator Detector*

The Low Battery Indicator Detector uses comparator U2-7. Bandgap reference VR2 is connected to the inverting input of the comparator, while the divided-down battery voltage is connected to the noninverting input. Resistor R16 provides the comparator with a hysteresis of approximately 0.25 V.

The comparator output is an open collector transistor connected to pull-up resistor R45 on the Main Circuit Assembly. When the battery pack voltage falls below about 7.7 V, U2-7 goes low. When the battery pack voltage rises above about 8.0 volts, U2-7 goes high. If the battery pack option is not installed, the pull-up resistor on the Main Circuit Assembly pulls the battery line high to keep the low battery indicator turned off.

7-8. *Low Battery Disconnect*

The Low Battery Disconnect uses FET switch Q2. The FET gate is driven by a latching circuit comprised of Q3, Q12, Q13, and VR4.

When the power switch is first turned on, a pulse through C15 turns on Q13, which then turns on Q3. With the Q3 collector voltage now near its emitter voltage and the FET gate near the battery voltage, the FET switch is on. At the same time, Q12 is turned on; its collector pulls down the base of Q3, latching the circuit on.

When the voltage between the base of Q12 and the anode of VR4 drops below 6.9 volts (battery voltage of about 7.0 volts), Q12 cannot be maintained on due to the 6.2 V zener diode in its emitter circuit, and the circuit unlatches itself. The gate of Q3 then goes to zero and turns off, disconnecting the battery pack. If the battery pack charge is low, this circuit does not latch, and the battery pack is protected from being deeply discharged.

7-9. Constant Voltage Trickle Charger

The Constant Voltage Trickle Charger uses a voltage regulator set at 9.25 volts. The output voltage is set by the values of R38, R40, and the setting of R39. The 30-volt supply on the Main Circuit Assembly provides the source for the regulator. Trickle charging occurs only when the meter is operated on line power.

If trickle charging occurs when the battery pack is low, R2 limits charging current to about 15 mA maximum.

When the meter is operated solely on battery pack power, the charger is disconnected from the battery pack. A logic level signal (ACON*) from the Main Circuit Assembly (J1-5) is maintained high, and the output of comparator U2-1 goes low, pulling U1-1 to common and setting the U1-2 output at 1.25 volts. CR4 is thus reversed biased, disconnecting the charger from the battery pack.

7-10. Other Circuits

During the various modes of operation, switching diodes provide the required battery pack connections. During battery pack operation of the meter, CR3 connects the battery pack to the switching supply on the Main Circuit Assembly. During charging (line power connected), CR5 connects the battery pack to the charging circuit. If line power is disconnected, CR9 disconnects the battery pack from the charging circuit.

The 5-amp battery pack fuse opens if either the battery pack is connected with the wrong polarity or if the battery pack output is shorted on the battery pack circuit board.

7-11. General Maintenance

7-12. Removal

Use the following instructions to remove the Battery Pack Option from the meter:

1. Make sure the meter is turned off and unplugged from the power outlet.
2. Remove the screw from the bottom of the case and the two screws from the rear bezel (as shown in Figure 7-2 detail A). While holding the front panel, slide the case and rear bezel off the chassis. (See Figure 7-2 detail B.) At this point, the rear bezel is not secured to the case.
3. Locate the flat white battery pack option cable connector at the Main PCA (see Figure 7-3.) Use needle nose pliers to detach this connection; alternately pull up on each end of this connector.

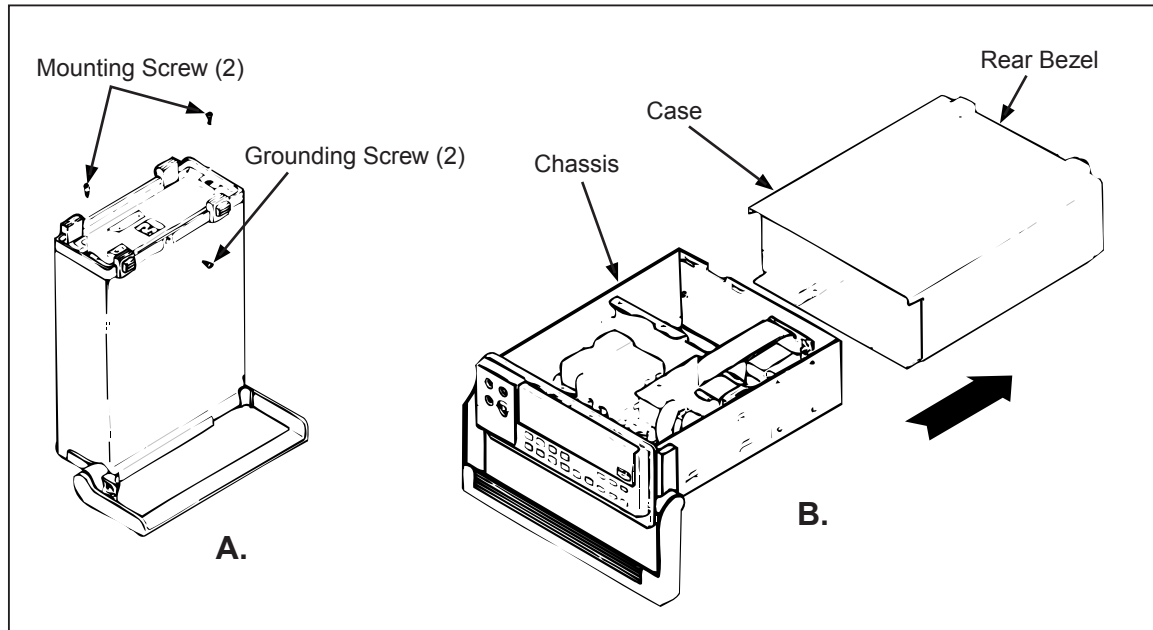

qb14f.eps

Figure 7-2. Removing the Case

4. Remove the two #6-32 x 1/4" panhead Phillips screws securing the Battery Pack Option (see Figure 7-4).
5. Carefully slide the Battery Pack Option out of the meter (as shown in Figure 7-4). Do not pinch the wires running from the circuit board to the battery terminals.

Caution

To prevent damage to the meter when servicing the Main PCA, unplug the battery pack ribbon cable at the Main PCA or disconnect the wires to the battery pack.

7-13. Installation

Use the following instructions to install the Battery Kit Option. Refer to the Instruction Sheet (PN 856013 - supplied with the Battery Kit) for the more detailed instructions required with an initial installation of the Battery Kit Option.

1. Make sure the meter is turned off and disconnected from line power.
2. With the meter disconnected from line power, discharge the power supply capacitor by turning the meter on. After five seconds, turn the meter off.
3. Carefully slide the battery kit into the area reserved for it in the back of the meter (as shown in Figure 7-4). Make sure that both the retaining slots line up and the mounting holes mate. Do not pinch wires running from the circuit assembly to the battery pack terminals.
4. Secure the battery kit with two #6-32 x 1/4" panhead Phillips screws.
5. Attach the flat, white connecting cable at the Battery Pack Option circuit board (see Figure 7-3). The single blue line of the cable should be to the rear of the meter. Align the plastic socket on the cable end, then seat it securely in place.
6. Reinstall the meter case to seat properly in the front panel. Attach the rear bezel with the two panhead Phillips screws, and secure the case with the flathead Phillips screw in the bottom.

7. To ensure that the battery kit is properly installed, turn the meter ON before connecting the power cord. If the meter does not turn on, the battery pack may be in the discharged state. Charge the battery pack for 16 hours; then retest.

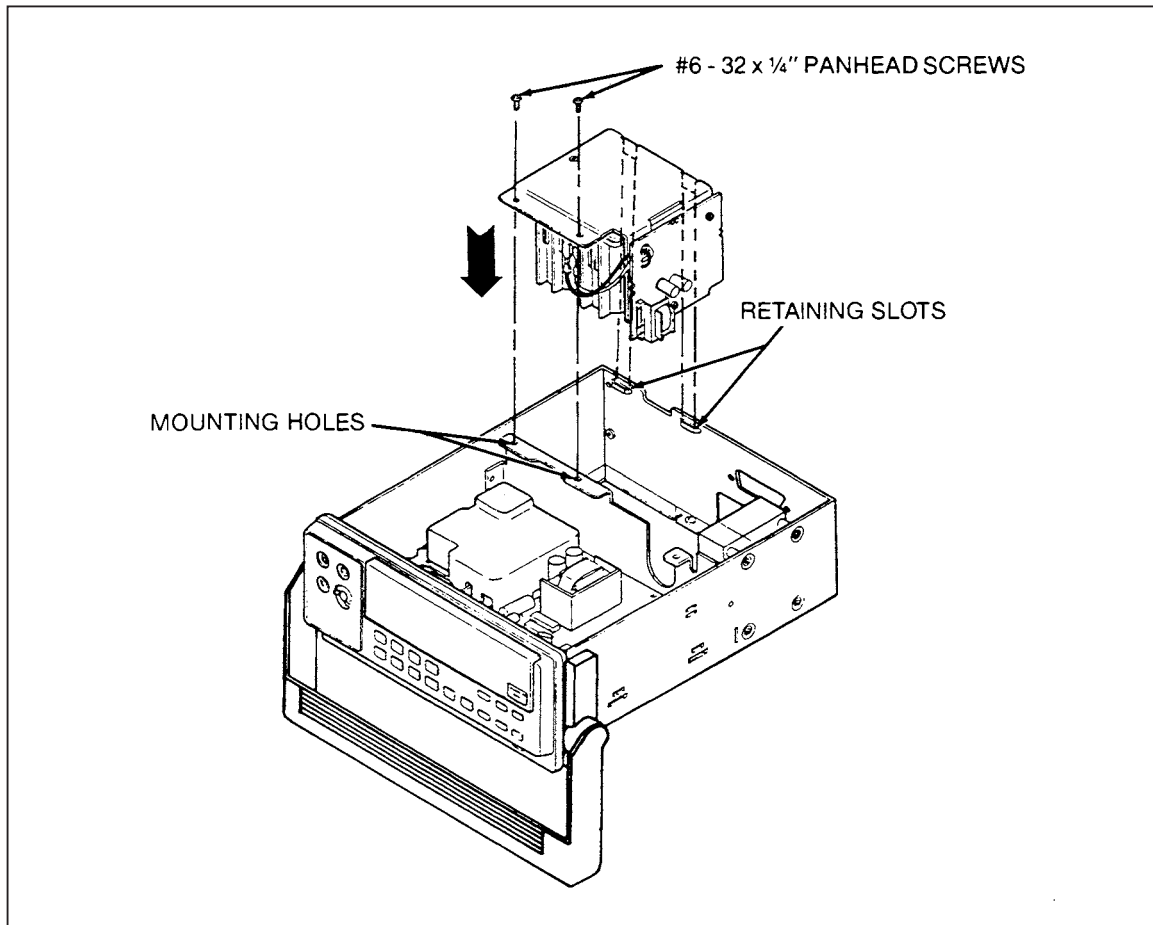
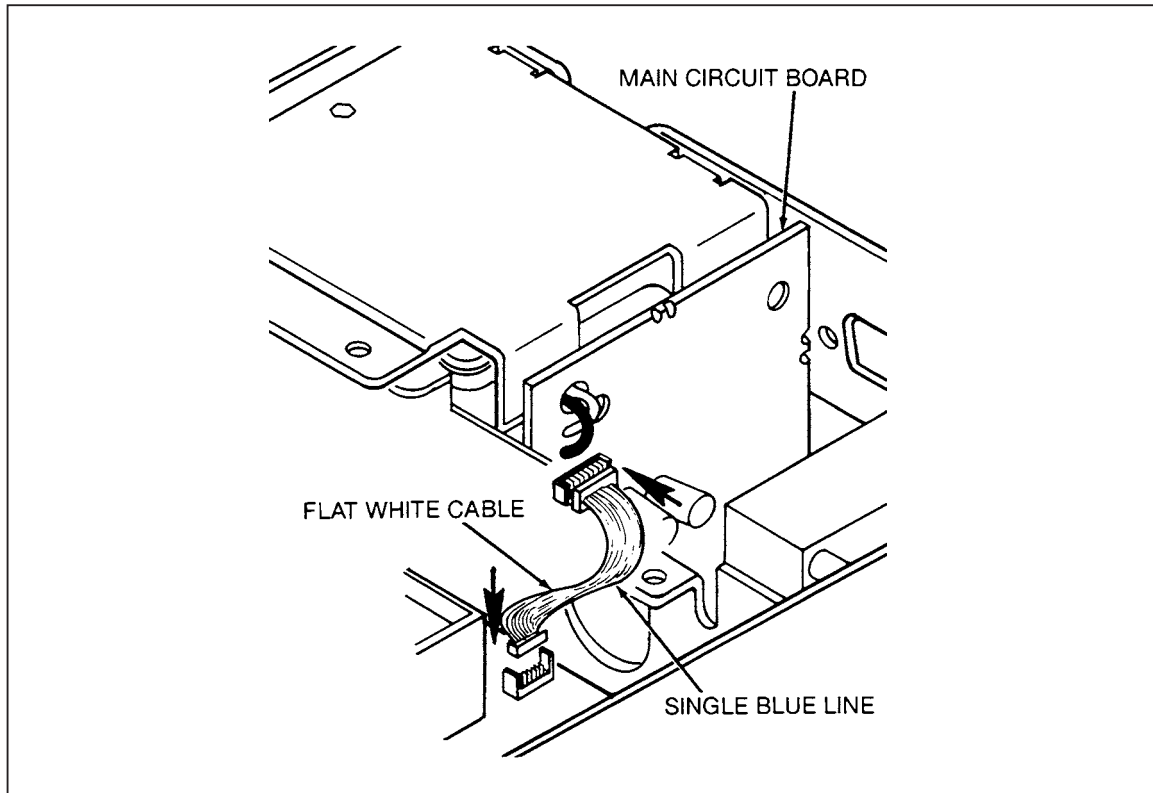

Figure 7-3. Installing the Battery Kit

qb35c.eps



qb34c.eps

Figure 7-4. Battery Pack Option Connecting Cable

7-14. Performance Testing

7-15. General Operability

The following performance verification assumes the following initial setup configuration:

- The Battery Pack Option is physically installed in the meter.
- The red and black battery pack wires have been disconnected.

Refer to Table 7-1 for description of any equipment that is required during the performance tests.

1. Disconnect the meter from line power. Now turn meter power on (1 = on), then off (0 = off).

Note

Do not connect the battery pack until after the option assembly is turned on later in this procedure.

2. Connect the 1.8 k Ω resistor across the battery pack wires. Connect the voltmeter (Low to TP1 and High to TP2.)
3. Connect the meter to line voltage, but do not turn the meter on.
4. Check for a voltmeter reading of 9.35 V \pm 0.01V.
5. Now turn power on. Check for a voltmeter reading of 9.25 V \pm 0.01 V.
6. Remove the voltmeter and the 1.8 k Ω resistor.

7. Observing the polarity markings on the battery pack, connect the red wire to the positive (+) terminal. Then connect the black (or brown) wire to the negative (-) terminal. Reversal of these connections causes fuse F1 to open.

7-16. Low Battery Indicator Detector and Low Battery Disconnect Test

The following test is necessary only after repairs have been made to either the Low Battery Indicator Detector or the Low Battery Disconnect circuit.

1. Turn the meter OFF.
2. Unplug the two battery pack connectors from the battery pack terminals. Observing the correct polarity, connect the variable power supply to the two battery pack connectors.
3. Connect the voltmeter across the variable power supply.
4. Set the variable power supply to approximately 9 volts.
5. Now turn the meter ON, and check for correct operation of the Low Battery Indicator symbol.
 - While watching the display, slowly lower the variable voltage power supply output. Check that the low battery indicator symbol comes on at 7.7 ± 0.25 V dc.
 - Now, slowly increase the variable voltage supply output. Check that the low battery indicator symbol goes out at about 8 V dc.
6. Check the Low Battery Disconnect point.
 - With the meter still operating on the variable supply, slowly lower the voltage, and check that the meter goes OFF at about 7.0 V dc.
 - After the meter goes OFF, slowly increase the voltage, and check that the meter does not come ON before approximately 8.0 V dc.

Note

The meter may not come on, above 8 volts until the power is cycled.

7. There are no adjustments to set the Low Battery Indicator point or the Low Battery Disconnect point.

7-17. Cycle/Float Charge Rate Switch Test

Use the following procedure to verify operation of the meter's Cycle/Float Charge Rate Switch. Note that this test is required only after repairs have been performed on the Cycle/Float Rate Switch Test circuits.

1. Turn the meter OFF.
2. For this procedure, use a battery simulator as a substitute for the regular battery pack. Connect this simulator (shown in Figure 7-5) as follows:
 - Connect a 33Ω , 5W load resistor in parallel across the output of a variable voltage power supply.
 - Disconnect the battery charger wires from the battery.
 - Connect the simulator to the battery charger wires. Install a 0.1Ω shunt resistor in series with the red wire.
 - Connect a voltmeter across the shunt resistor to measure the voltage drop across and the charging current through the resistor.

3. With no ac line power applied to the meter, adjust the variable voltage power supply for 8.5 V dc output.
4. Now apply ac line power, and check that the charging current is greater than 250 mA.
5. Slowly increase the variable voltage supply output. Check for the following:
 - The charging current decreases as the supply voltage approaches 10 V dc.
 - The current should continue to decrease as the voltage increases, until the current is between 60 and 80 mA.
 - With any additional decrease in current (increase of the supply voltage), the current should suddenly jump to a low value (less than 0.5 mA.)
 - When the variable voltage supply output is reduced to 9.35 V dc, the current should be between 5 and 15 mA.

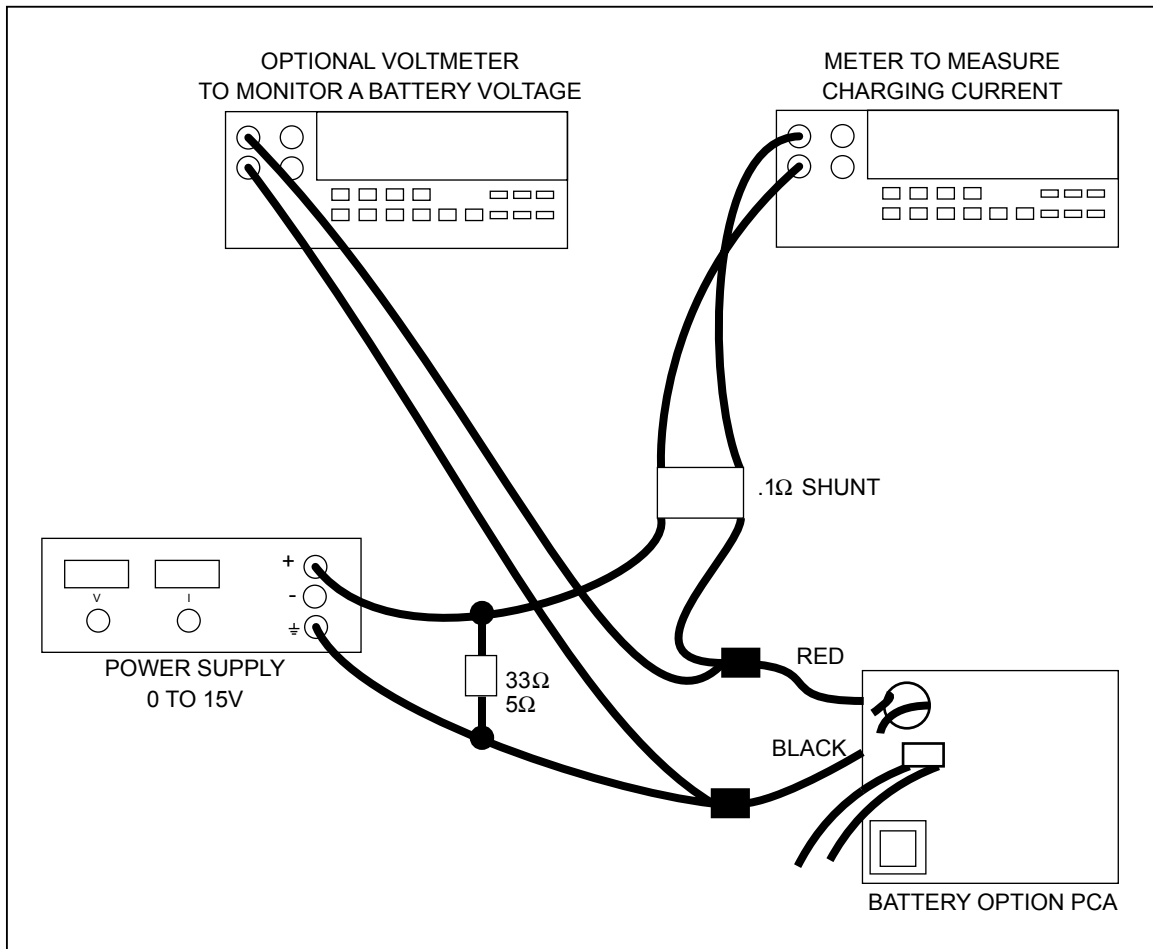

Figure 7-5. Cycle/Float Charge Rate Switch Test

qb36f.eps

7-18. Calibration

The Battery Pack Option is adjusted at the factory for optimum performance and should not require adjustment when installed. However, if either of the two adjustment pots on the top of the Battery Pack Option circuit assembly have been turned inadvertently, or if the unit has been repaired, the following procedure can be used to reset the controls for optimum battery life and proper power supply system performance.

The following equipment is needed to perform these adjustments:

- An 1800 Ω , 1/2 watt, 5% resistor
- A voltmeter

The following steps describe how to adjust the Battery Pack Option:

1. With the Battery Pack Option installed in the meter and with the meter disconnected from line power, unplug the battery connectors from the battery + and - terminals (Figure 7-6).
2. Install the 1800 Ω resistor across the battery pack connectors.
3. Connect the meter to line power and turn the meter ON.
4. Connect the test leads from another voltmeter across test points TP1 and TP2 on the Battery Pack Option circuit assembly (as shown in Figure 7-7). Adjust the front potentiometer (R39) (top of the Battery Pack Option circuit assembly) until the voltmeter across the test points reads 9.25 V.
5. Turn the meter OFF.
6. Connect the test leads from another voltmeter across TP1 and TP2 on the battery pack option circuit assembly. Adjust rear potentiometer R20 (top of the battery pack option circuit assembly) until the voltmeter across the test points reads 9.35 volts. (With the meter connected to line power and turned off, the charging voltage reads approximately 9.35 volts.)
7. Disconnect the line cord from the meter.
8. Remove the 1800 Ω resistor, and plug the battery pack connector wires back into the battery pack (the red wire to + and the black wire to -.)
9. To ensure the battery pack connector wires are properly connected and the battery kit is properly installed, turn the meter ON without plugging in the power cord.

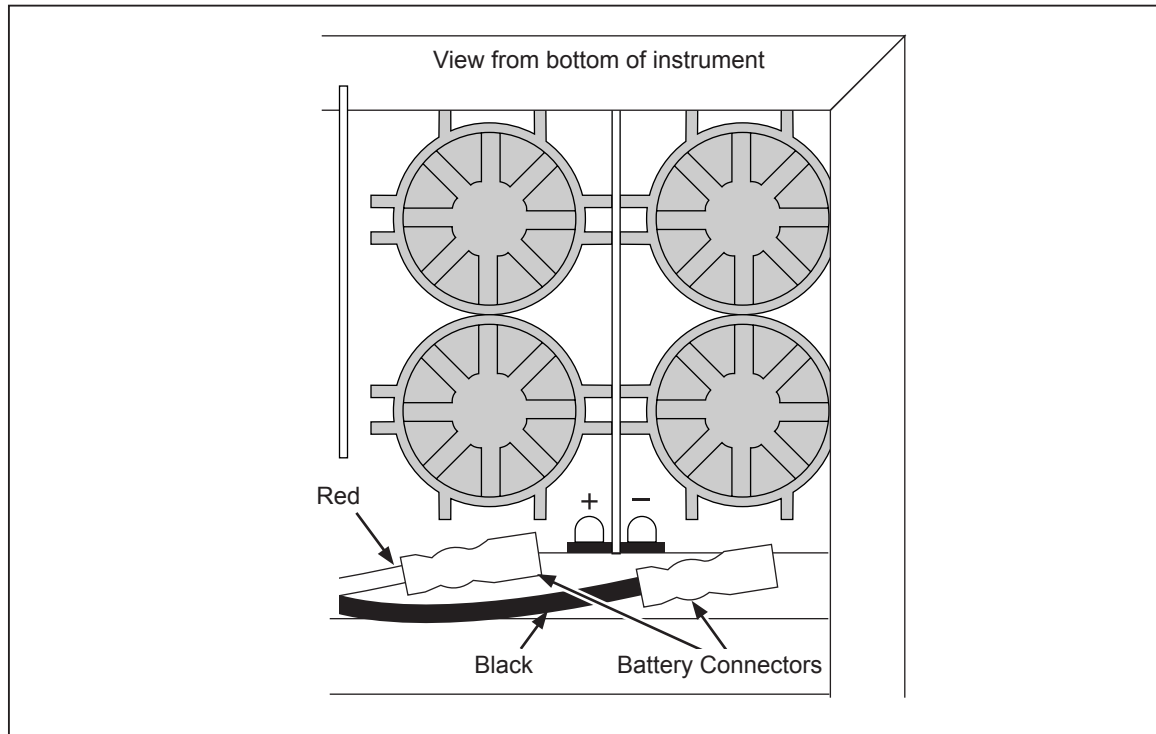

Figure 7-6. Unplugging the Battery Pack Connectors

qb37f.eps

7-19. Troubleshooting

Troubleshooting can be facilitated by removing the Battery Pack Option and connecting the Battery PCA with an extender cable (Fluke Part Number 854245). Refer to the removal instructions provided earlier in this chapter.

With the meter off (but plugged into line power), check for approximately 16 V dc (at 120V ac line) raw dc supply between the ground test point and the cathode of either A1CR2 or A1CR3. If necessary, check for transformer secondary voltage of approximately 24 V ac.

Use an oscilloscope to trace the waveforms associated with the switching power supply.

- With the line voltage at 120 V ac, check the waveform at the drain of FET Q5. This signal should be a 25 V p-p square wave, with the negative part at zero volts, a period of 20 to 25 μ s, and an ON duty ratio of .20 to .50. This square wave may exhibit a damped sine wave (two to ten cycles) ringing on the trailing half of the positive portion. The sine wave amplitude should be from 10 to 20 V p-p.
- Check for a 15 V p-p square wave at the gate of Q5.
- Check for a 14 V p-p square wave at U4-5.
- Check for a 0.5 V p-p sawtooth waveform (with a period of 20 to 25 μ s) at U4-3. Make sure that the oscilloscope is ac-coupled for this measurement.

Troubleshoot other sections of the Battery Pack Option assembly by making dc voltage measurements. For circuit common, use the GND test point on the main circuit board or the common end of R30 on the Battery Pack PCA. Note that the battery pack negative terminal is not connected to common when the low battery disconnect circuit turns off Q2.

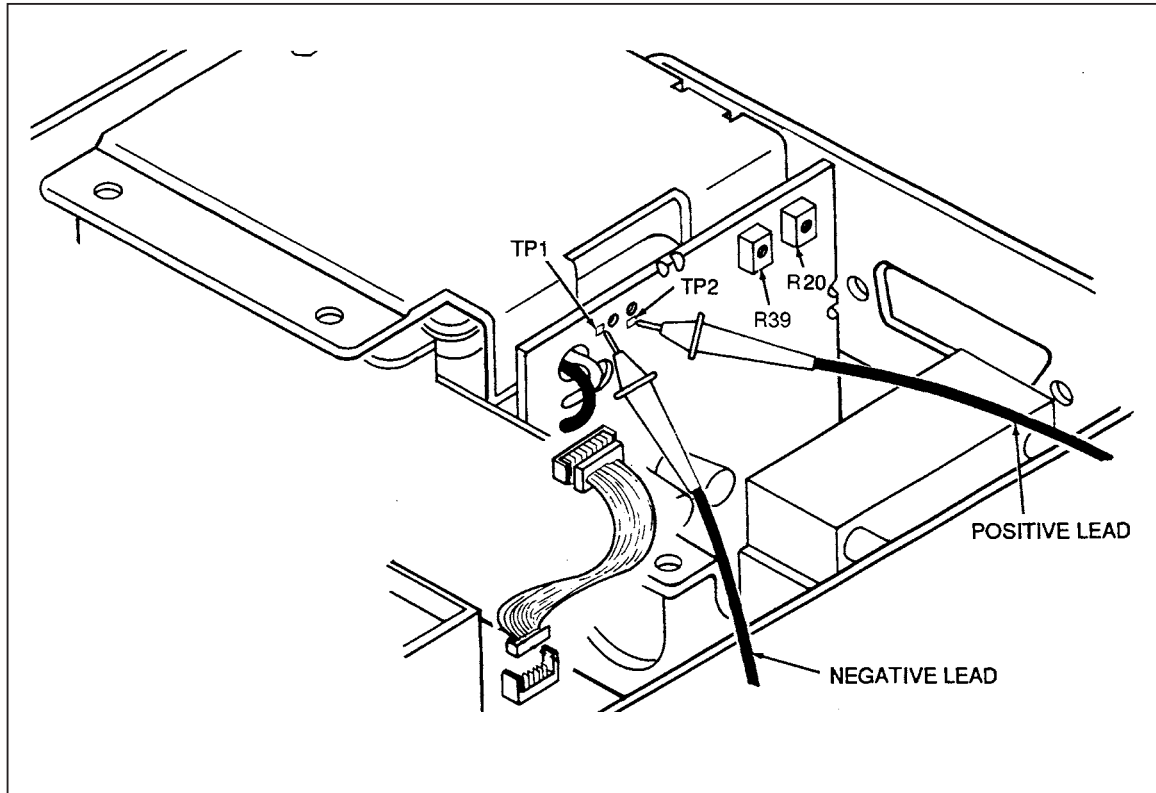

qb38c.eps

Figure 7-7. Test Points and Adjustments

7-20. Additional Tests

The Low Battery Indicator Detector/Low Battery Disconnect Test and the Cycle/Float Charge Switch Test described earlier under Performance Testing can also be used as fault isolation aids in troubleshooting the Battery Pack Option.

7-21. Schematic Diagram

The schematic diagram for the Battery Pack Option is included in Chapter 9 of this manual.

7-22. List of Replaceable Parts

Figures 7-8 and 7-9 provide illustration for parts list in Tables 7-2 and 7-3, respectively. Refer to Chapter 6 for parts ordering information.

Table 7-1. Option -01 Battery Pack Final Assembly

Reference Designator		Description	Fluke Stock No.	Total Qty.	Note
A	4	* BATTERY PCA	825885	1	
BT	1	BATTERY, LEAD-ACID, 8.0V, 2.5AH	822262	1	
H	1-4	SCREW, PH, P, LOCK, STL, 6-32, .250	152140	4	
MP	1	RETAINER, BATTERY	828814	1	
MP	34	TAPE, FOAM, URETHANE, ADHES., .063, .500	854539	1	
TM	1	FLUKE 45 BATTERY KIT INST SHEET	856013	1	
W	1	CABLE ASSY, FLAT, 10 COND, MICROMOD, 3 IN	831552	1	

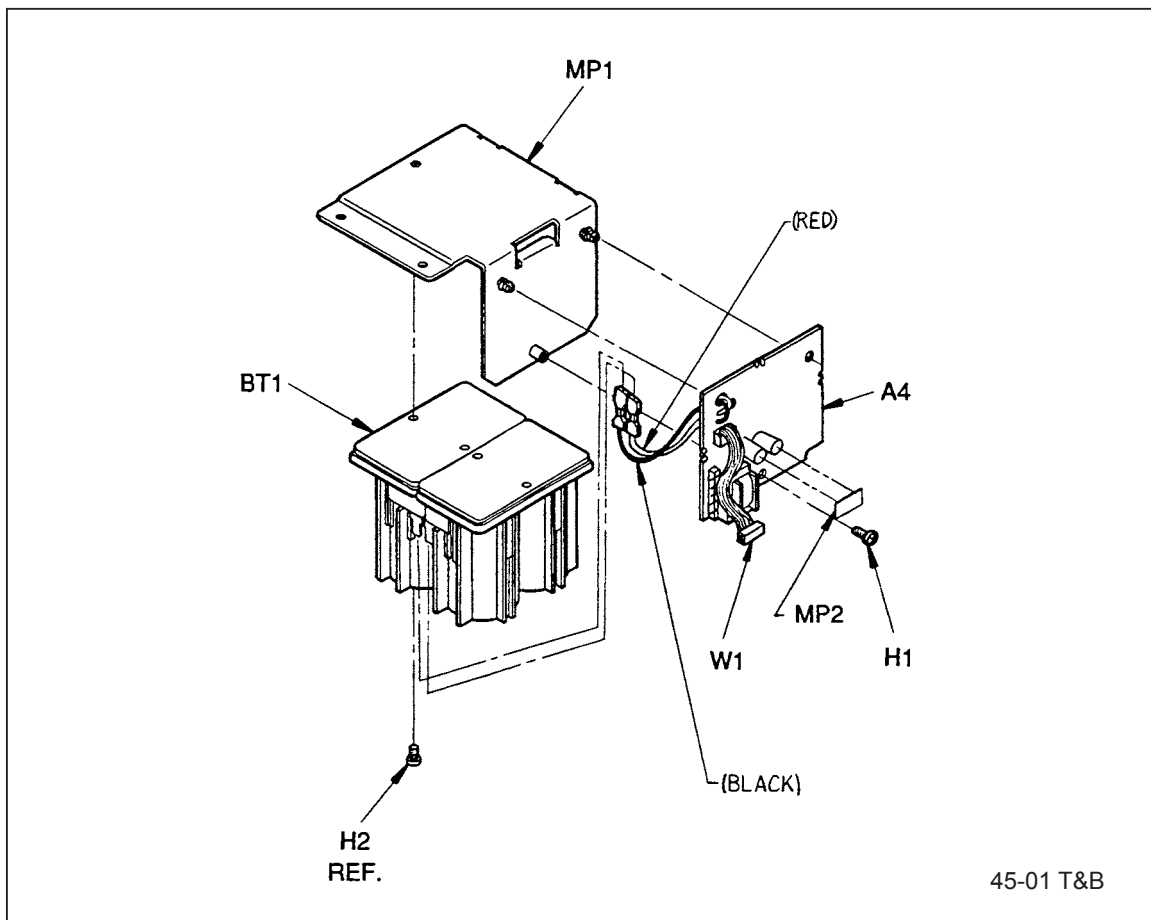

Figure 7-8. Option-01 Battery Pack Final Assembly

Table 7-2. A4 Battery Pack PCA

Reference Designator		Description	Fluke Stock No.	Total Qty.	Note
C	6, 7	CAP,CER,1800PF,+/-10%,50V,C0G,1206	769786	2	
C	8	CAP,CER,33PF,+/-10%,50V,C0G,1206	769240	1	
C	9	CAP,AL,47UF,+/-20%,50V,SOLV PROOF	822403	1	
C	11	CAP,AL,10UF,+/-20%,63V,SOLV PROOF	816843	1	
C	12	CAP,AL,47UF,+/-20%,100V,SOLV PROOF	837492	1	
C	13	CAP,AL,1000UF,+/-20%,16V,SOLV PROOF	837468	1	
C	14	CAP,CER,0.22UF,+80-20%,50V,Y5V,1206	740597	1	
C	15	CAP,AL,2.2UF,+/-20%,50V,SOLV PROOF	769687	1	
CR	3, 5, 9	* DIODE,SI,SCHOTTKY BARRIER,40V,1A	837732	3	
CR	4, 7, 8	* DIODE,SI,BV=75V,IO=250MA,SOT23	830489	3	
CR	10	DIODE,SI,100 PIV,1.0 AMP	698555	1	
CR	11	DIODE,SI,100 PIV,3.3 AMP,SCHOTTKY	837740	1	
F	1	FUSE,.095X.28,5A,125V,FAST,AXIAL	696427	1	
J	1	HEADER,1 ROW,.050CTR,10 PIN	831503	1	
Q	2, 5	* TRANSISTOR,SI,NMOS,1W,D-PAK	822106	2	
Q	3, 7	* TRANSISTOR,SI,PNP,SMALL SIGNAL,SOT-23	742684	2	
Q	4, 6, 12, 13	* TRANSISTOR,SI,NPN,SMALL SIGNAL,SOT-23	742676	4	
R	2	RES,MOX,1.5K,+/-5%,1W	603685	1	
R	3, 42	* RES,CERM,47K,+/-5%,.125W,200PPM,1206	746685	2	
R	11	* RES,CERM,130K,+/-5%,.125W,200PPM,1206	851761	1	
R	13	* RES,CERM,523K,+/-1%,.125W,100PPM,1206	844956	1	
R	14	* RES,CERM,100K,+/-1%,.125W,100PPM,1206	769802	1	
R	15	* RES,CERM,10.5K,+/-1%,.125W,100PPM,1206	851852	1	
R	16, 43	* RES,CERM,10M,+/-5%,.125W,300PPM,1206	783274	2	
R	17	* RES,CERM,470K,+/-5%,.125W,200PPM,1206	746792	1	
R	18	* RES,CERM,330K,+/-5%,.125W,200PPM,1206	746776	1	
R	19	* RES,CERM,51K,+/-5%,.125W,200PPM,1206	746693	1	
R	20	RES,VAR,CERM,10K,+/-20%,0.3W	837559	1	
R	21	* RES,CERM,59K,+/-1%,.125W,100PPM,1206	851803	1	
R	22	* RES,CERM,301K,+/-1%,.125W,100PPM,1206	821652	1	
R	23	* RES,CERM,470,+/-5%,.125W,200PPM,1206	740506	1	
R	24	* RES,CERM,3.3K,+/-5%,.125W,200PPM,1206	746529	1	
R	25	RES,METAL FILM,2.26k,+/-1%,0.5W	603693	1	
R	26, 44	* RES,CERM,10,+/-5%,.125W,200PPM,1206	746214	2	
R	27	* RES,CERM,100K,+/-5%,.125W,200PPM,1206	740548	1	
R	28	* RES,CERM,12,+/-5%,.125W,200PPM,1206	845458	1	
R	29, 34- 37	RES,CF,0.50,+/-5%,0.25W	830646	5	
R	30	RES,CF,560,+/-5%,0.25W	810440	1	
R	31	* RES,CERM,100,+/-5%,.125W,200PPM,1206	746297	1	
R	32, 41	* RES,CERM,1K,+/-5%,.125W,200PPM,1206	745992	2	
R	33	* RES,CERM,120,+/-5%,.125W,200PPM,1206	746305	1	
R	38	* RES,CERM,910,+/-5%,.125W,200PPM,1206	769257	1	
R	39	RES,VAR,CERM,200,+/-20%,0.3W	837567	1	
R	40	* RES,CERM,6.8K,+/-5%,.125W,200PPM,1206	746024	1	
R	45	* RES,CERM,2.2K,+/-5%,.125W,200PPM,1206	746479	1	

Table 7-2. A4 Battery Pack PCA (cont)

Reference Designator		Description	Fluke Stock No.	Total Qty.	Note
T	1	INDUCTOR,FXD,DUAL,EE24-25,0.4MH,1.2A	817379	1	
U	1	* IC,VOLT REG,ADJ,1.2 TO 37 V,1.5 AMPS	460410	1	
U	2	* IC,COMPARATOR,DUAL,LOW PWR,SOIC	837211	1	
U	3	* IC,CMOS,HEX BUFFERS,SOIC	837229	1	
U	4	* IC,VOLT REG,ADJ,SWITCHING REGULATOR	821215	1	
VR	2	* IC, 1.23V,150 PPM T.C.,BANDGAP V. REF	634451	1	
VR	3	* ZENER,UNCOMP,15V,5%,8.5MA,0.2W,SOT-23	83787	1	
VR	4	* ZENER,UNCOMP,6.8V,5%,20MA,0.2W,SOT-23	83795	1	
W	1	WIRE ASSY,BATTERY,BLACK	834960	1	
W	2	WIRE ASSY,BATTERY,RED	844332	1	

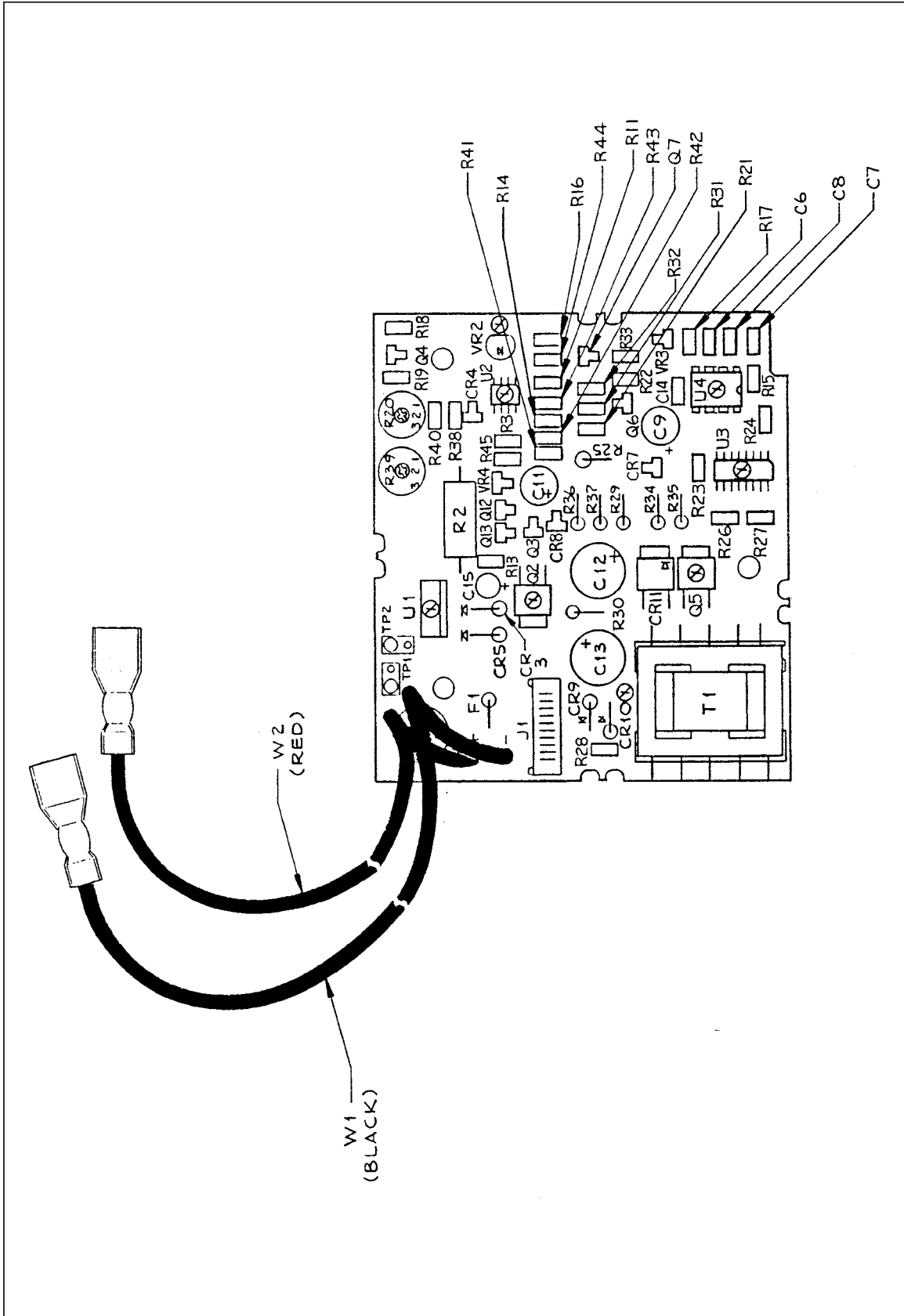

Figure 7-9. A4 Battery Pack PCA

qb40c.eps

Chapter 8

Option -05 IEEE-488 Interface

	Title	Page
8-1.	Introduction.....	8-3
8-2.	Theory of Operation	8-3
8-3.	Functional Block Description.....	8-3
8-4.	Detailed Circuit Description.....	8-3
8-5.	Main Assembly Connectors	8-3
8-6.	Address Decoding Circuit.....	8-3
8-7.	Isolation Circuits	8-4
8-8.	IEEE-488 Controller	8-4
8-9.	IEEE-488 Transceivers/Connector.....	8-5
8-10.	General Maintenance	8-8
8-11.	Removing the IEEE-488 Interface Option	8-8
8-12.	Installing the IEEE-488 Interface Option.....	8-9
8-13.	Performance Testing.....	8-9
8-14.	Troubleshooting.....	8-10
8-15.	Power-up Problems	8-10
8-16.	Communication Problems	8-10
8-17.	Failure to Select IEEE-488 Interface Option	8-10
8-18.	Failure to Handshake on IEEE-488 Bus	8-11
8-19.	Failure to Enter Remote	8-11
8-20.	Failure to Receive Multiple Character Commands.....	8-12
8-21.	Failure to Transmit Query Responses.....	8-12
8-22.	Failure to Generate an End or Identify (EOI)	8-12
8-23.	Failure to Generate a Service Request (SRQ).....	8-12
8-24.	Schematic Diagram.....	8-12
8-25.	List of Replaceable Parts	8-12

8-1. Introduction

The IEEE-488 Interface turns the Fluke 45 into a fully programmable instrument for use with the IEEE Standard 488.1 (1987) interface bus (IEEE-488 bus). With the IEEE-488 Interface, the Fluke 45 can become part of an automated instrumentation system.

8-2. Theory of Operation

8-3. Functional Block Description

The IEEE-488 Assembly (A5) requires power supply voltages, address, data and control signals from the Fluke 45 Main Assembly (A1) to operate. The A5 assembly implements the circuitry necessary to satisfy the IEEE-488.1 standard for programmable instrumentation.

8-4. Detailed Circuit Description

The IEEE-488 Assembly comprises the following functional blocks: the Main Assembly Connectors, the Address Decoding Circuit, the Isolation Circuits, the IEEE-488 Controller, and the IEEE-488 Transceivers and Connector. These five blocks are described in the following paragraphs. Signal names mentioned during this discussion are:

ACON*AC line power on

IRQ2*IEEE-488 interrupt request

OPSIEEE-488 option sense

OPTSW* IEEE-488 option power switch control signal

8-5. Main Assembly Connectors

The IEEE-488 Assembly interfaces with the Main Assembly through two ribbon cables that mount to the 14-position and 20-position connectors on each assembly. The 20-pin connector (A5J2) routes the 16-bit address bus from the Microprocessor (A1U6) to the circuitry on the IEEE-488 Assembly. The 14-position connector (A5J3) passes the eight-bit data bus and memory control signals between the two assemblies.

The IEEE-488 Assembly is powered by the +5.2V dc power supply (VCC) from the Main Assembly. VCC is connected to the IEEE-488 Assembly via A5J3-1. The logic common return (GND) is through A5J2-20.

8-6. Address Decoding Circuit

When a memory read or memory write cycle intended for the IEEE-488 Controller (A5U6) is in progress, the 13 address bits ADD(15) through ADD(3) from A1U6 are decoded by A5U1, A5U2, and A5U5 to generate an active low chip-select signal. The chip-select signal (A5U5-8) goes low when two events occur: OPTSW* (A5J3-12) is near -5.2V dc (VEE), and the address bus indicates that the Microprocessor is accessing memory between addresses 0028 and 002F hexadecimal (inclusive). When the Fluke 45 is operating on battery power, the Microprocessor turns off the power to the IEEE-488 Assembly by driving the OPTSW* signal (A5J3-12) to VCC. This signal drives A5U1-6 to about +4.3V dc (through A5CR1), disabling the Address Decoding Circuit.

8-7. Isolation Circuits

The Isolation Circuits allow the Microprocessor to turn off power to the A5U6, A5U7, and A5U8 components. These three components consume the majority of the power on the IEEE-488 Assembly; normal meter operation on batteries is extended by approximately 100% with this power isolation scheme.

The Microprocessor determines that the IEEE-488 Assembly is installed in the meter by checking the state of the OPS signal (A5J2-18). This signal is pulled up to VCC by resistor A1R39 and is shorted to logic ground on the IEEE-488 Assembly. If A1U6-29 is low, the Microprocessor assumes that the IEEE-488 Assembly is installed. If the ACON* signal (A1U6-33) is low (indicating operation on ac power), the Microprocessor drives A1U6-28 high. As a result, the OPTSW* signal (A1U7-3) is driven to VEE, and transistor A5Q1 turns on. This transistor passes current from the VCC power supply to the VCC2 power supply to bias A5U6, A5U7, and A5U8. Normally VCC2 is approximately 0.1V less than VCC.

When OPTSW* (A5J3-12) is near VCC (battery operation), diode A5CR1 and pulldown resistor A5R1 cause the non-inverting octal tri-state buffer (A5U4) to be tri-stated off by holding inputs A5U4-1 and A5U4-19 near VCC. This octal buffer isolates six Microprocessor outputs (ADD(2), ADD(1), ADD(0), WR*, RD, and E clock) from the IEEE-488 Controller (A5U6) when the meter is operating on batteries. A5U4 also buffers the chip-select signal (A5U5-8) that goes to A5U6 and the interrupt output signal from A5U6-10.

The eight bit data bus from the Microprocessor is isolated from A5U6 by an octal bus transceiver with tri-state outputs (A5U3). This transceiver is enabled only when the Address Decoding Circuit detects that a memory cycle for the IEEE-488 Assembly is in progress and A5U3-19 is driven low. If the memory cycle is a read cycle, the R/W* signal (A5U3-1) is high and the transceiver buffers the eight bit data from A5U6 to A1U6. If the memory cycle is a write cycle, the R/W* signal (A5U3-1) is low and the transceiver buffers the eight-bit data from A1U6 to A5U6.

8-8. IEEE-488 Controller

The IEEE-488 Controller (A5U6) is an integrated circuit that performs the transfer of information between the IEEE-488 standard bus and the Microprocessor. Once it has been programmed by the Microprocessor via the eight register microprocessor interface, A5U6 performs IEEE-488 bus transactions independently until it must interrupt the Microprocessor for additional information or data.

The IEEE-488 Controller is clocked by a 921.6-kHz square-wave clock. This clock (A5U4-5) is generated by buffering the E clock (A5U4-15) from the Microprocessor. The IEEE-488 Controller uses this clock to run the internal state machines that handle IEEE-488 bus transactions.

The IEEE-488 Controller can be given a hardware reset with either of the following two methods:

- If the system reset signal RESET (A5J3-14) goes high or if OPTSW* (A5J3-12) goes high, then NOR gate output A5U2-10 goes low, and the D flip-flop Q output A5U9-9 goes low. This flip-flop output drives the reset input (A5U6-22), forcing the IEEE-488 Controller into its reset state.
- When the meter is initially powered up, both RESET and OPTSW* are high, forcing the IEEE-488 Controller reset input (A5U6-22) to be low. As long as OPTSW* is high, VCC2 is near ground and A5U6 is not biased, so A5U6-22 is held low to avoid sourcing current into A5U6-22 while A5U6 is unbiased.

When the Microprocessor drives OPTSW* to VEE to enable the VCC2 power supply, the CLR* input to the D flip-flop (A5U9-13) goes high to enable the flip-flop. The Q output (A5U9-9) remains low until the Microprocessor does an initial dummy memory cycle to the IEEE-488 Controller (approximately 1 ms later.) The rising edge at the end of the chip select signal (A5U9-11) clocks the flip-flop and causes the Q output to go high. This action removes the hardware reset to the IEEE-488 Controller. This delay is followed by another dummy read cycle and a series of six memory write cycles that program the IEEE-488 Controller.

For each character that it receives or transmits, the IEEE-488 Controller generates an interrupt to the Microprocessor. These interrupts are generated by driving the open-drain interrupt output A5U6-10 low. This signal is buffered by a tri-state buffer whose output at A5U4-3 drives the IRQ2* input to the Microprocessor low. When the Microprocessor responds to the interrupt and takes the necessary actions by reading and writing registers in the IEEE-488 Controller, both A5U6-10 and, subsequently, A5U4-3 go high again. Resistor A5R3 provides a pull-up termination on open-drain interrupt output A5U6-10. Tri-state buffer output A5U4-3 is pulled up by resistor A5R2 to terminate the IRQ2* signal when the buffer is tri-stated off.

When the Microprocessor performs a memory cycle to the IEEE-488 Controller, the lower three bits of the address bus that are buffered by A5U4 (ADD(2) through ADD(0)) select the register being accessed in A5U6. When a memory read cycle is performed, chip-enable A5U6-3 goes low, and A5U6-5 (DBIN) goes high. These actions enable A5U6, driving the contents of the selected register onto the data bus and through the data bus transceiver to the Microprocessor. When a memory write cycle is performed, chip-enable A5U6-3 goes low, and A5U6-4 (WE*) goes first low and then high to latch the data being driven from the Microprocessor (through A5U3) into the IEEE-488 Controller.

The IEEE-488 Controller interfaces to the IEEE-488 Transceivers using an eight-bit data bus, eight interface signals, and two transceiver control signals (A5U6-33 and A5U6-24).

The controller-in-charge signal (A5U6-33), which should always be high, controls the direction of the SRQ, ATN, IFC, and REN IEEE-488 transceivers in A5U8.

The talk enable output (A5U6-24) is either low when the IEEE-488 Controller is not addressed to talk or high when the controller is addressed to talk. This signal determines the direction of all IEEE-488 Transceivers except SRQ, ATN, IFC, and REN.

8-9. IEEE-488 Transceivers/Connector

The IEEE-488 Transceivers (A5U7 and A5U8) are octal transceivers that are specifically designed to exhibit the proper electrical drive characteristics to meet the IEEE-488 standard. These transceivers are configured to match the control signals available on the IEEE-488 Controller. Assuming that A5U6-33 is always high, Table 8-1 describes the transceiver direction control. The IEEE-488 Transceivers connect to a 24-position connector, which mates with the ribbon cable leading to the IEEE-488 connector mounted at the rear of the meter chassis.

Table 8-1. IEEE-488 Transceiver Control

Transceiver	TE = 0 (Listener)	TE = 1 (Talker)
DI01..DI08	Receiver	Transmitter
SRQ	Transmitter	Transmitter
ATN	Receiver	Receiver
EOI	Receiver	Receiver (ATN = 0)
	Receiver	Transmitter (ATN = 1)
DAV	Receiver	Transmitter
NRFD	Transmitter	Receiver
NDAC	Transmitter	Receiver
IFC	Receiver	Receiver
REN	Receiver	Receiver

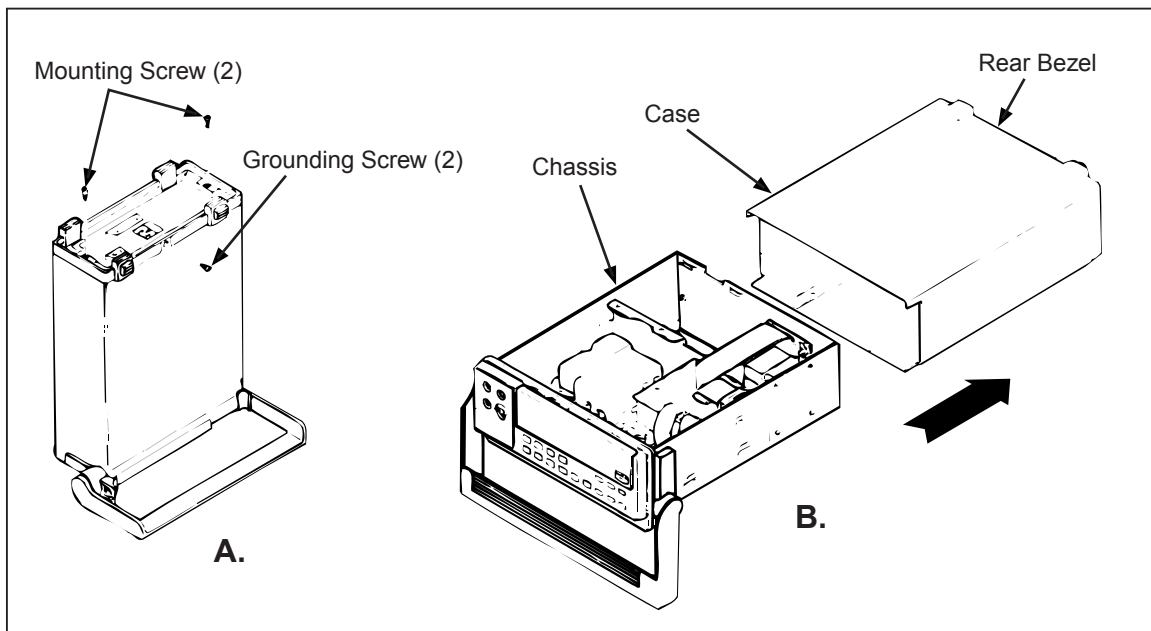

Figure 8-1. Disassembly

qb14f.eps

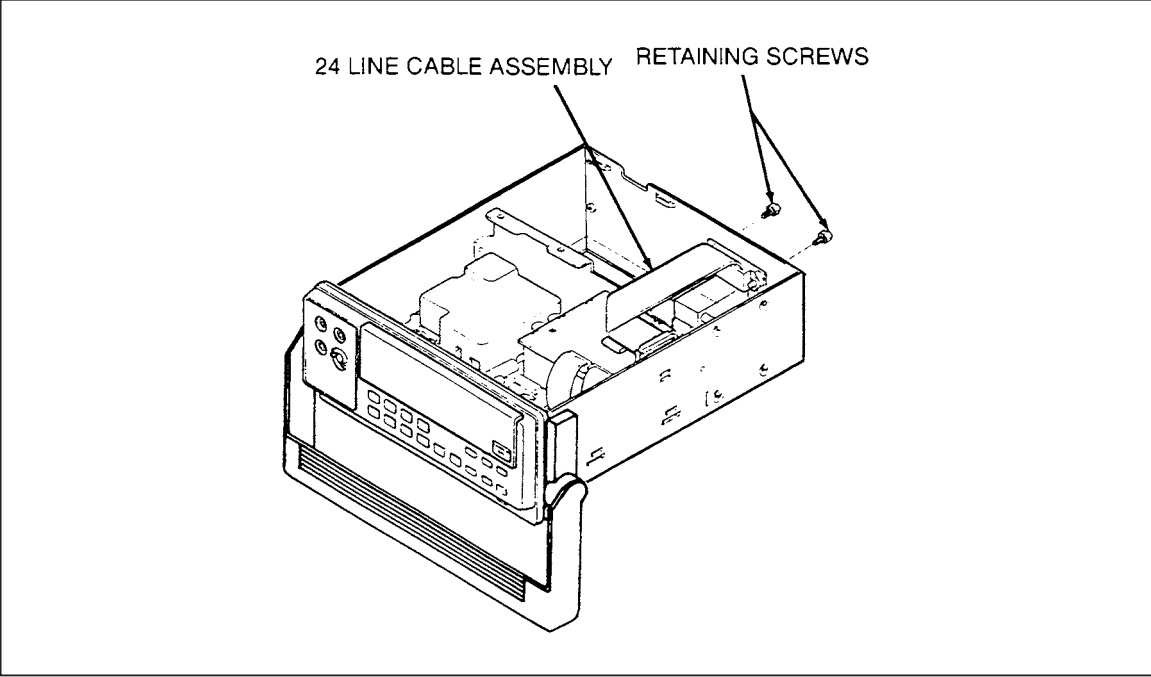

Figure 8-2. IEEE-488 Interface Connector

qb41c.epc

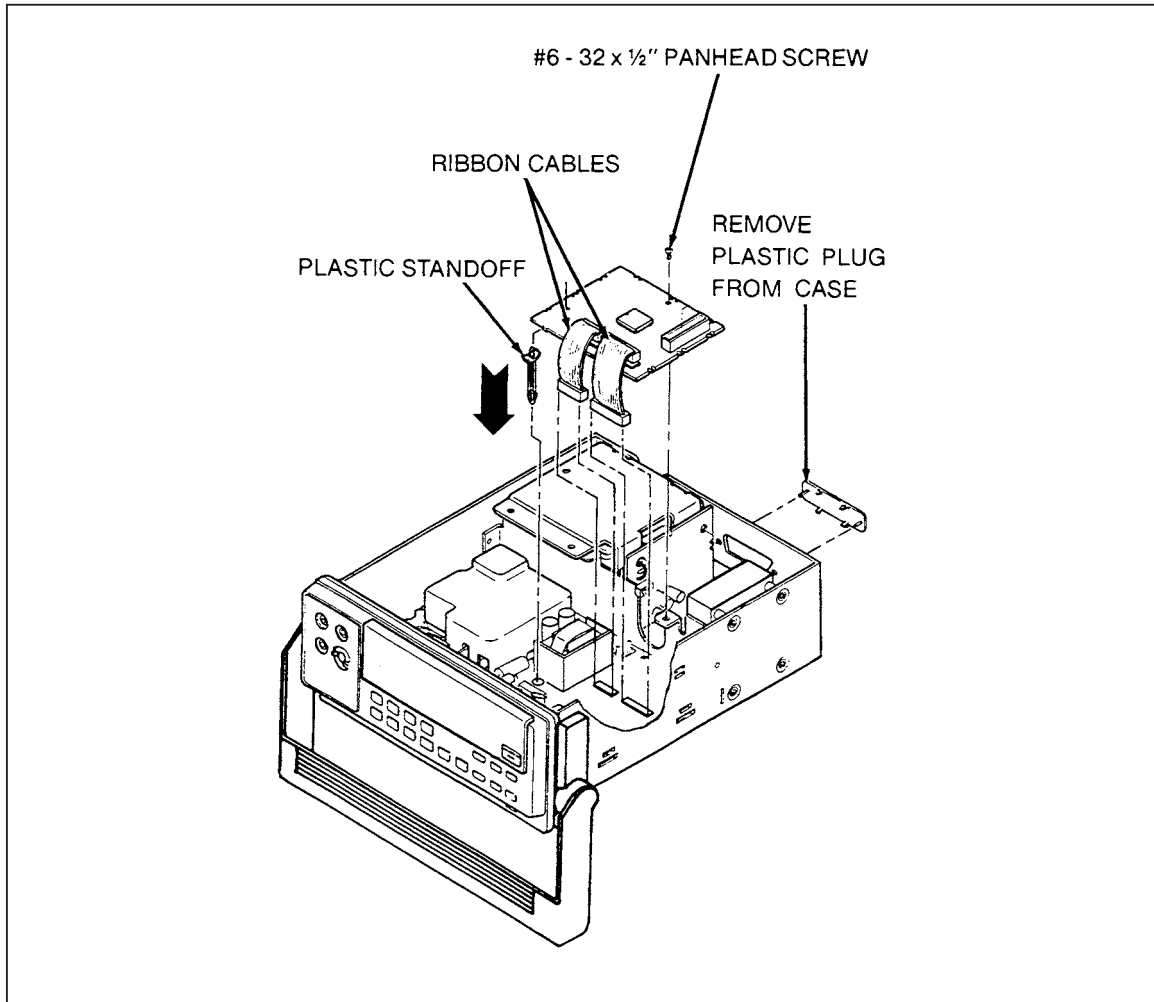

Figure 8-3. IEEE-488 Module Assembly

qb42c.eps

8-10. General Maintenance

8-11. Removing the IEEE-488 Interface Option

The following instructions can be used for access and servicing an IEEE-488 Interface Option that is already installed in a Fluke 45 Dual Display Multimeter. For initial installation, refer to the Instruction Sheet (PN 856005) provided with the option.

1. Make sure the meter is turned off and unplugged from the power outlet.
2. Remove the screw on the bottom of the meter case and the two screws from the rear bezel (as shown in Figure 8-1A). While holding the front panel, slide the case and rear bezel off the chassis (see Figure 8-1B). (At this point, the rear bezel is not secured to the case.)
3. Using needle nose pliers, disconnect the 24-line cable assembly at the IEEE-488 PCA by alternately pulling up on each end of its connector. See Figure 8-2.
4. Refer to Figure 8-3 for the remaining steps. Remove the panhead Phillips screw at the rear of the IEEE-488 PCA.

5. Using needle nose pliers, detach the two ribbon cables at the front part of the IEEE-488 PCA. Alternately pull up on each end of the cable connectors.
6. Remove the IEEE-488 PCA, disengaging the assembly from both the small slot in the side of the meter and the plastic standoff at the front corner of the assembly.

8-12. Installing the IEEE-488 Interface Option

Use the following procedure to install the IEEE-488 Interface Option.

1. Turn the meter off, and unplug the power connection.
2. Check that the plastic standoff remains in the appropriate hole in the meter PCA (narrow end of the standoff down; see Figure 8-3).
3. If necessary, install the two ribbon cables on the IEEE-488 PCA. Each cable fits in only one socket and in only one direction. Make sure the cables lock firmly in place.
4. Attach opposite ends of the ribbon cables onto the Fluke 45 Main PCA.
5. Install the IEEE-488 PCA in the Fluke 45 with the dual ribbon cables facing the front of the meter. The IEEE-488 PCA slips into the small slot in the side of the meter. The end of the plastic standoff fits into the hole in the IEEE-488 PCA. Make sure the IEEE-488 PCA is firmly gripped against the retainer on the standoff. The rear of the IEEE-488 PCA should rest upon the support just forward of the transformer.
6. Secure the rear of the IEEE-488 PCA with the panhead Phillips screw.
7. Connect the 24-line cable assembly to the IEEE-488 PCA. (See Figure 8-2.)
8. Reinstall the meter case so it seats properly in the front panel. Attach the rear bezel with the two panhead Phillips screws, and secure the case with the flathead Phillips screw in the bottom.

8-13. Performance Testing

Use the performance test program in Figure 8-1 to verify operation of the IEEE-488 Interface. This program is written for use with the Fluke 182A Instrument Controller and its interpreted BASIC language. The program may be adapted to the language of any IEEE-488 controller.

This performance test communicates to a meter that has been configured for IEEE-488 operation at address 0. Lines 160 and 170 initialize the IEEE-488 bus and send a selective device clear to the meter. A multiple byte command is sent to the meter (by line 190) to clear the meter status. Another command sequence (including a query) is sent to the meter by line 210; the meter asserts Service Request (SRQ) to signal that a response is available. Lines 530 through 560 first poll the meter for status, then input the response from the meter. Lines 230 through 270 test for proper operation and print the results.

```

140 IA% = 0%                ! instrument IEEE address
150 S% = -1%               ! initialize spl response
160 TERM                   ! terminate input only on EOI
170 INIT PORT 0           ! initialize IEEE-488 bus
180 CLEAR @IA%            ! selective device clear
190 PRINT @IA%,"*cls"     ! clear instrument status
200 ON SRQ GOTO 530       ! enable SRQ interrupt
210 PRINT @IA%,"*cls;*sre 16;*idn?" ! SRQ on Message Available
220 WAIT 500% FOR SRQ    ! allow time to execute commands
230 IF S% >= 0% THEN 260
240   PRINT "Instrument failed to generate a Service Request"
250   STOP
260 PRINT "Serial Poll =";S%;"(should be 80)."

```

Figure 8-4. IEEE-488 Interface Performance Test

8-14. Troubleshooting

8-15. Power-up Problems

The following discussion identifies probable fault areas if the installation of an IEEE-488 Interface Option causes power-up failure for the Fluke 45. The problem is probably a short on A5P2 or A5P3; the Microprocessor on the Main Assembly is prevented from accessing ROM and RAM correctly. Two extender cables are available (PN 867952 and 867957) to assist during troubleshooting.

- The first thing to check is whether GND is shorted to either VCC or VCC2 on the IEEE Assembly.
- The short may also be an interface signal to either VCC, GND, or another interface signal. The logical signals to check are DATA(7..0), ADD(15..0), RD*, WR*, E, and RESET*.
- The short may be due to a CMOS input that has been damaged from static discharge; the short is then detectable only when the circuit is powered up. Use an oscilloscope to check activity on each of the interface signals. Verify that signals are able to transition normally between 0 and 5V.

8-16. Communication Problems

8-17. Failure to Select IEEE-488 Interface Option

IEEE-488 Interface selection procedures are described in Chapter 3.

If the IEEE-488 Interface Option is not detected by Fluke 45 software, there may be a problem with the OPS or ACON* signal. The IEEE Interface Option grounds the OPS signal (A5P2-18), which is normally pulled up to VCC on the Fluke 45 Main Assembly. The Microprocessor determines that the IEEE-488 Interface Option is not installed if OPS (A1U6-29) is detected high.

Further, software does not allow the IEEE-488 Interface Option to be selected if the ACON* signal is detected high. Since ACON* is high when the meter is operating on battery power, the IEEE-488 Interface Option cannot be selected as the active interface during battery operation. The displayed "IEEE" message is dim, and the battery indicator blinks if the Fluke 45 software detects ACON* to be high when the option editor is entered. The ACON* signal (A1U6-33) is low when the meter is operating from line power.

8-18. *Failure to Handshake on IEEE-488 Bus*

Check VCC2 with a voltmeter. When the Fluke 45 is operating on line power, VCC2 should be about 0.1V lower than VCC. VCC2 is controlled by the Microprocessor, which sets A1U6-28 high when operating on line power and causes OPTSW* to be driven to a -5.0V dc level. The OPTSW* signal controls the gate of FET switch A5Q1 on the IEEE-488 Interface Option to turn VCC2 on.

The Reset circuit consists of A5CR1, A5R1, A5U2, and A5U9. When the meter is operating on batteries, the Reset circuit converts the OPTSW* signal to a digital signal that disables access to A5U6. When operating from batteries, OPTSW* is at about 5.0V dc, A5U2-9 is high, A5U2-10 is low, and A5U9-9 is low to reset A5U6 via pin 22.

When the meter is connected to ac line voltage again, this circuit resets A5U6. OPTSW* transitions to -5.0V dc, A5U2-9 is low (near GND), A5U2-10 is high, and A5U9-9 stays low until the Address Decoder detects a memory access to the IEEE-488 Interface Option. About 1.0 ms after OPTSW* goes to -5.0V dc, the initial read access clocks A5U9-11, causing A5U9-9 to go high to remove the reset from A5U6-22. This action is followed by another "dummy" read cycle for delay. The Main Assembly then sends six write cycles to initialize A5U6. The IRQ2 interrupt is then enabled, and the serial poll status byte is initialized. At this point, the IEEE-488 Interface Option is ready to respond to transactions on the IEEE-488 bus.

Note

Each time that the IEEE Interface Option is selected in the BAUD menu (by pressing [AUTO]), the IEEE-488 Interface Option initialization is repeated as described above, with the exception that no hardware reset is performed via the OPTSW signal.*

8-19. *Failure to Enter Remote*

If the IEEE-488 Interface Option does not enter remote, check that the remote/local control circuit is operating properly. When the IEEE-488 Interface Option is the active instrument interface, the remote/local control state is polled by the Main PCA approximately every 1.0 ms. Normally, A5U5-8 goes low for approximately 1.0 μ s during the read cycle that checks the state of A5U6. If A5U3-11 is low during the read cycle, A5U6 is in the local state. If A5U3-11 is high during the read cycle, A5U6 is in the remote state. When A5U6 indicates that it is in remote, the REMOTE indicator on the display is turned on.

8-20. Failure to Receive Multiple Character Commands

Monitor the interrupt signal from A5U6-10 during attempts to communicate with the meter. Each byte received with the ATN signal (A5U6-31) high should cause the interrupt signal to go low. Follow the interrupt signal through A5U4, and verify that it arrives at A5J3 properly. If the interrupt is not detected by A1U6, it will remain low indefinitely. A5U6-10 will only go high when both the interrupt is detected and the received byte is removed from A5U6 by A1U6.

8-21. Failure to Transmit Query Responses

Check that TE (A5U6-24) goes high when the interface is addressed to talk. This signal must go high to allow the bus interface transceivers to change the direction of DIO1 through DIO8, EOI, DAV, NRFD, and NDAC. Verify that each of these signals passes through A5U7 and A5U8 properly.

8-22. Failure to Generate an End or Identify (EOI)

When the IEEE-488 Interface Option sends the Line Feed termination character with a message, the EOI signal should also be set true. When EOI is true, A5U6-30 should go low. Follow this signal from A5J1 through A5U8 to A5U6.

8-23. Failure to Generate a Service Request (SRQ)

When a Service Request is being generated, A5U6-32 should be low. Follow this signal through A5U8 to connector A5J1. When a Serial Poll (SPL) is performed by the IEEE-488 bus controller, A5U6-32 will go high again.

Note

If the meter is in the remote state without front panel lockout (i.e., REMS), a service request can be sent from the front panel by pressing [UPB].

8-24. Schematic Diagram

The schematic diagram for the IEEE-488 Interface Option is included in Chapter 9 of this manual.

8-25. List of Replaceable Parts

Figures 8-4 and 8-5 provide illustration for the parts lists in Tables 8-3 and 8-4, respectively. Refer to Chapter 6 for parts ordering information.

Table 8-2. Option -05 IEEE-488 Interface Final Assembly

Reference Designator		Description	Fluke Stock No.	Total Qty.	Note
A	5	IEEE-488 INTERFACE PCA	814152	1	
H	1	SCREW,PH,P,LOCK,STL,6-32,.250	152140	1	
H	2	CONN ACC,MICRO-RIBBON,SCREW LOCK KIT	836585	1	
MP	1	SPACER,SNAP,PWB,NYL,1.375	845347	1	
TM	1	PRINT MATL,INST SHT,FLUKE 45/IEEE-488	856005	1	
W	7	CABLE ASSY,IEEE	834978	1	
W	8	CABLE ASSY,FLAT,14 COND,MICROMOD,3 IN	831560	1	
W	9	CABLE ASSY,FLAT,20 COND,MICROMOD,3 IN	831578	1	

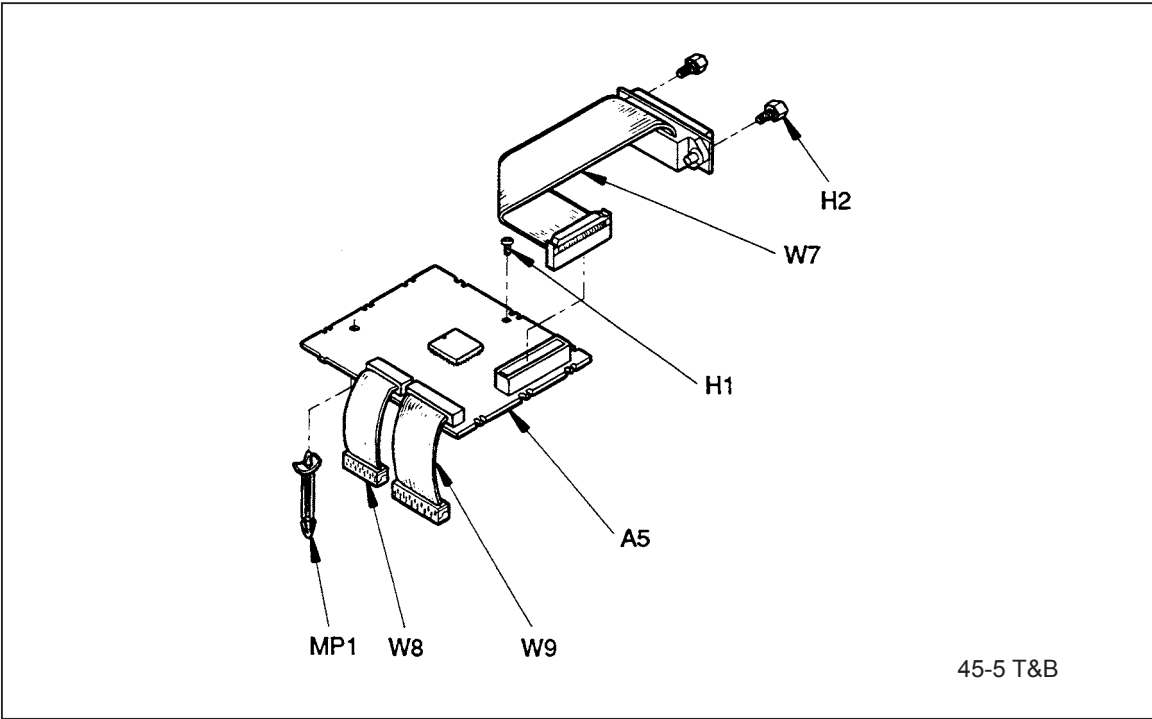

Figure 8-5. Option -05 IEEE-488 Interface Final Assembly

qb43c.eps

Table 8-3. A5 IEEE-488 Interface PCA

Reference Designator		Description	Fluke Stock No.	Total Qty.	Note
C	6- 11	CAP,CER,0.1UF,±10%,25V,X7R,1206	747287	6	
C	12	CAP,CER,0.022UF,±10%,50V,X7R,1206	747279	1	
CR	1	* DIODE,SI,BV=75V,IO=250MA,SOT23	830489	1	
J	1	HEADER,2 ROW,.100CTR,24 PIN	831834	1	
J	2	HEADER,1 ROW,.050CTR,20 PIN	831529	1	
J	3	HEADER,1 ROW,.050CTR,14 PIN	831511	1	
Q	1	* TRANSISTOR,SI,PMOS,1W,D-PAK	836544	1	
R	1,3	* RES,CERM,5.1K,±5%,.125W,200PPM,1206	746560	2	
R	2	* RES,CERM,47K,±5%,.125W,200PPM,1206	746685	1	
R	4	* RES,CERM,220,±5%,.125W,200PPM,1206	746347	1	
U	1,2	* IC,CMOS,QUAD INPUT NOR GATE,SOIC	830711	2	
U	3	* IC,CMOS,OCTAL BUS TRANSCEIVER,SOIC	742577	1	
U	4	* IC,CMOS,OCTL LINE DRVR,SOIC	801043	1	
U	5	* IC,CMOS,8 INPUT NAND GATE,SOIC	830729	1	
U	6	* IC,NMOS,GPIB CONTROLLER,PLCC	887190	1	
U	7	* IC,LSTTL,OCTAL GPIB XCVR,SOIC	831651	1	
U	8	* IC,LSTTL,OCTAL GPIB XCVR,SOIC	831669	1	
U	9	* IC,CMOS,DUAL D F/F,+EDG TRG,SOIC	782995	1	

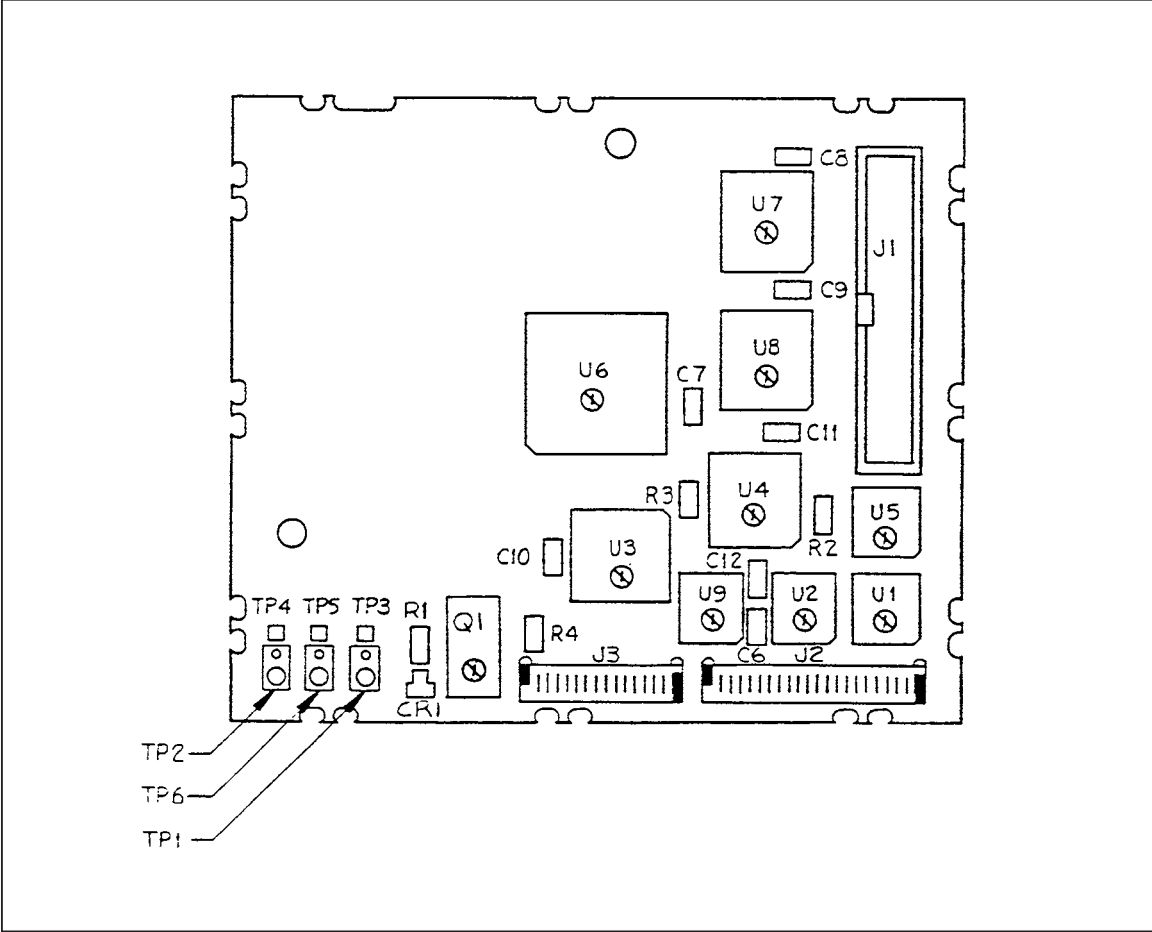

Figure 8-6. A5 IEEE-488 Interface PCA

qb44c.eps

Chapter 9

Schematic Diagrams

Figure	Title	Page
9-1	A1 Main PCA	9-2
9-2	A2 Display PCA	9-8
9-3	A1A1 True Rms PCA	9-10
9-4	A4 Battery PCA	9-12
9-5	A5 IEEE-488 Interface PCA.....	9-14

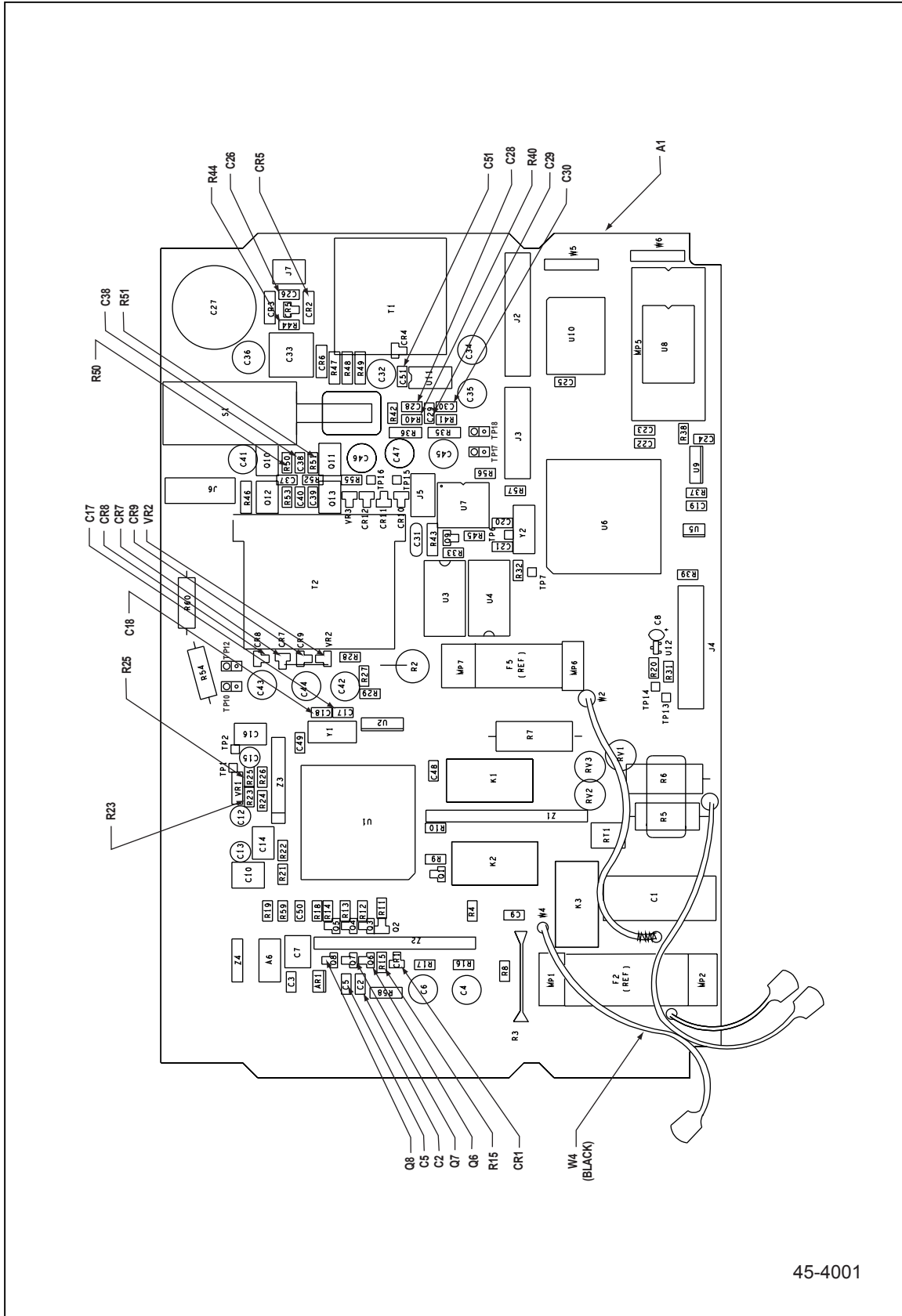
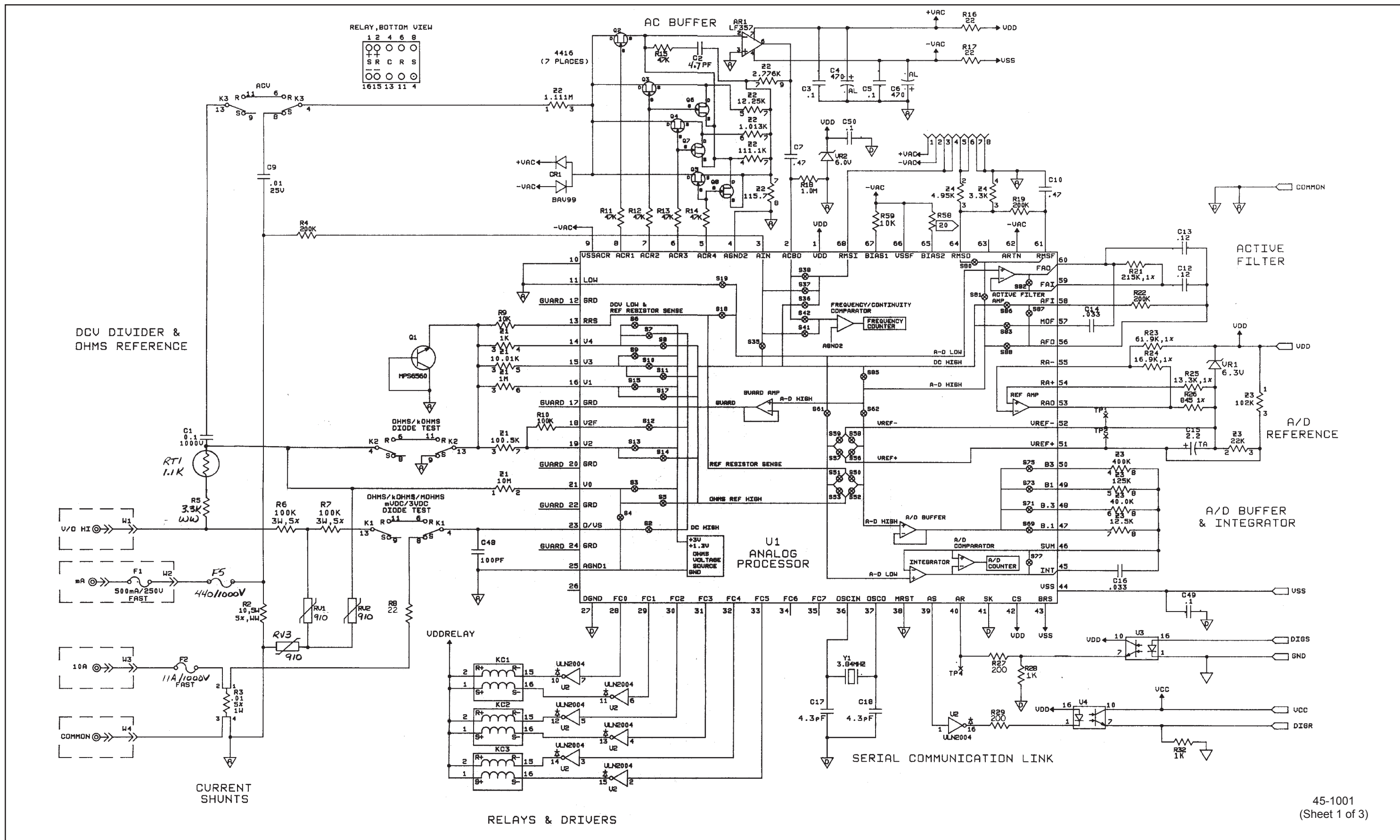

Figure 9-1. A1 Main PCA

qb30f.eps



45-1001 (Sheet 1 of 3)

Figure 9-1. A1 Main PCA (cont)

qb45sc.tif

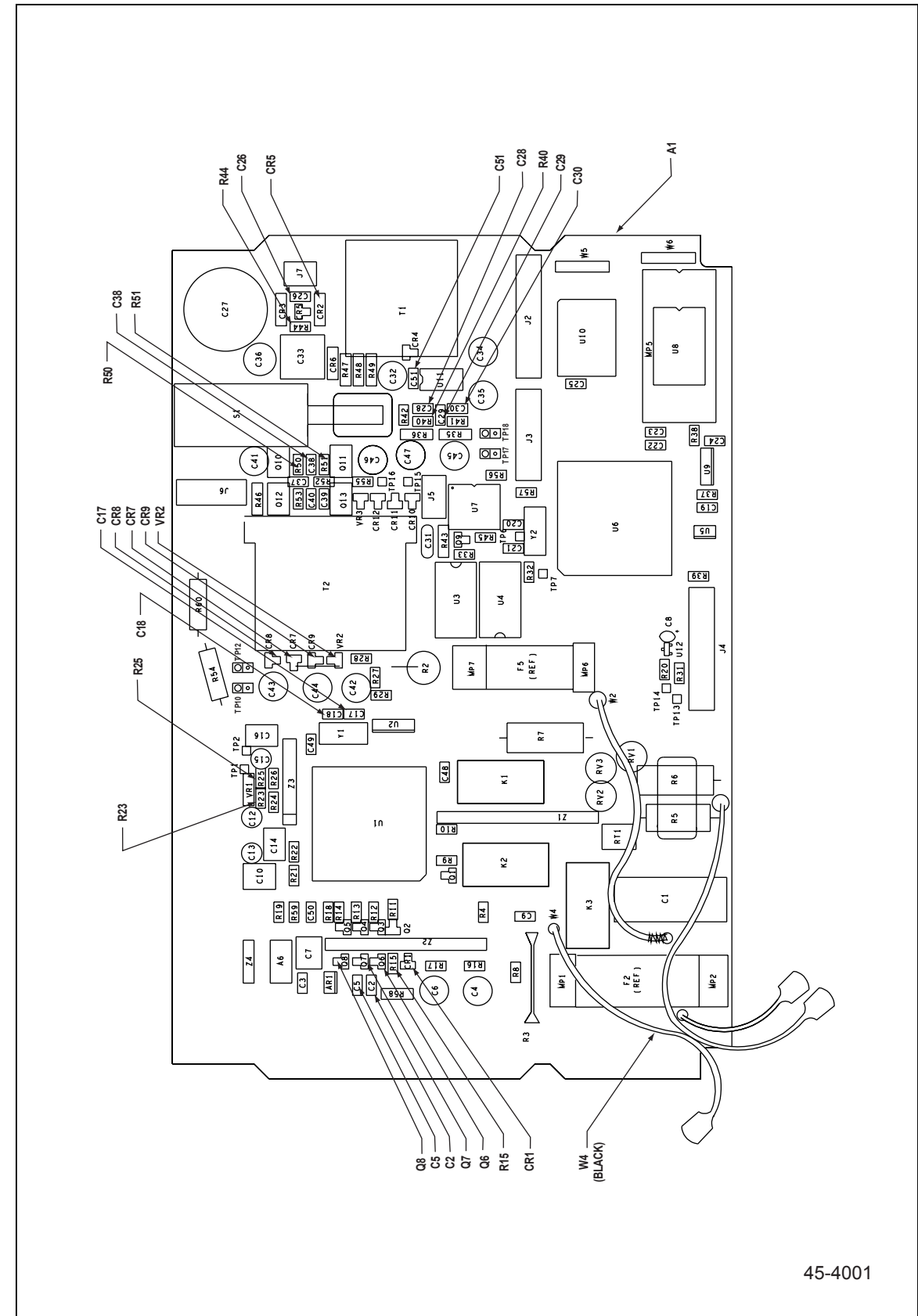
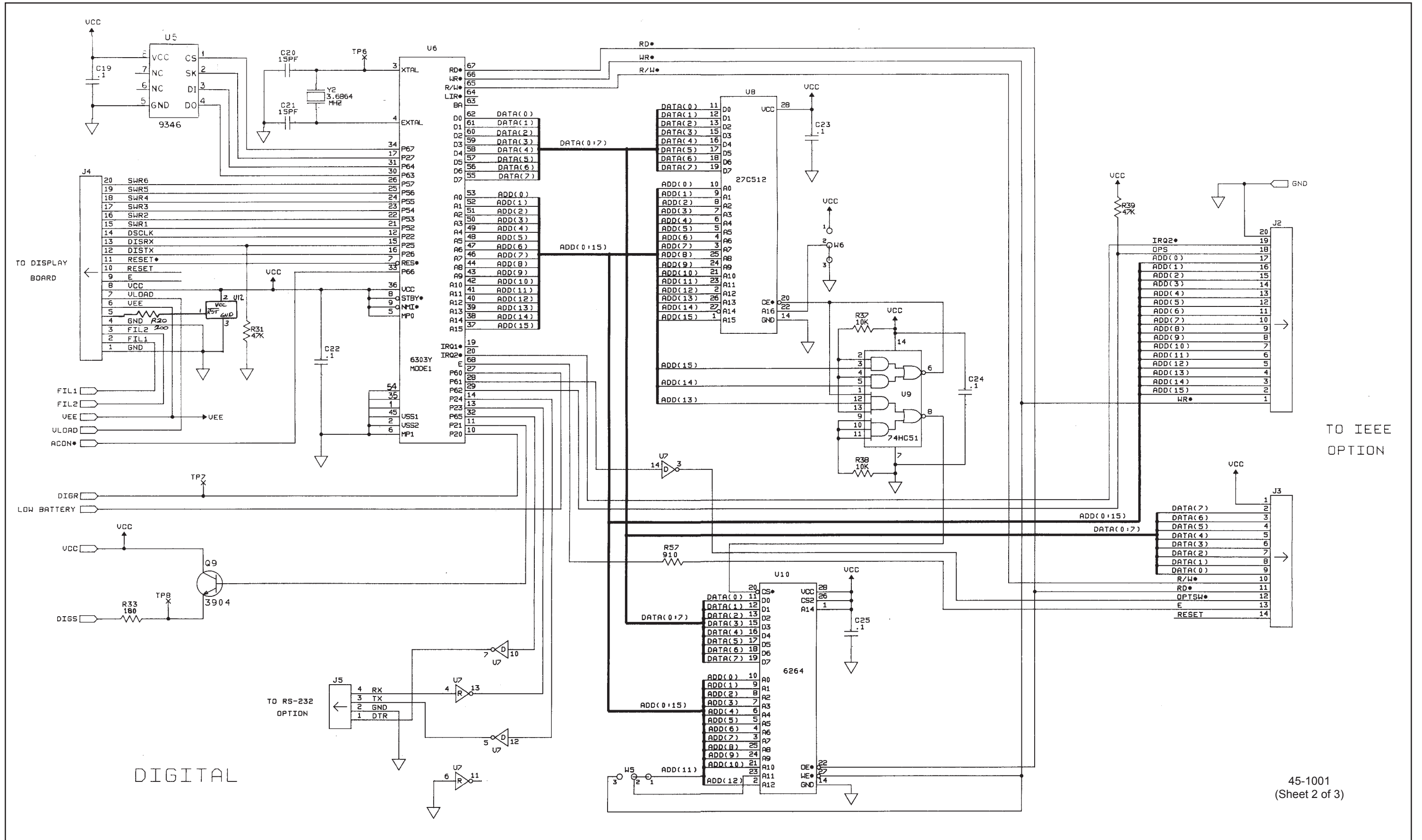

Figure 9-1. A1 Main PCA (cont)



DIGITAL

45-1001
(Sheet 2 of 3)

Figure 9-1. A1 Main PCA (cont)

qb46sc.tif

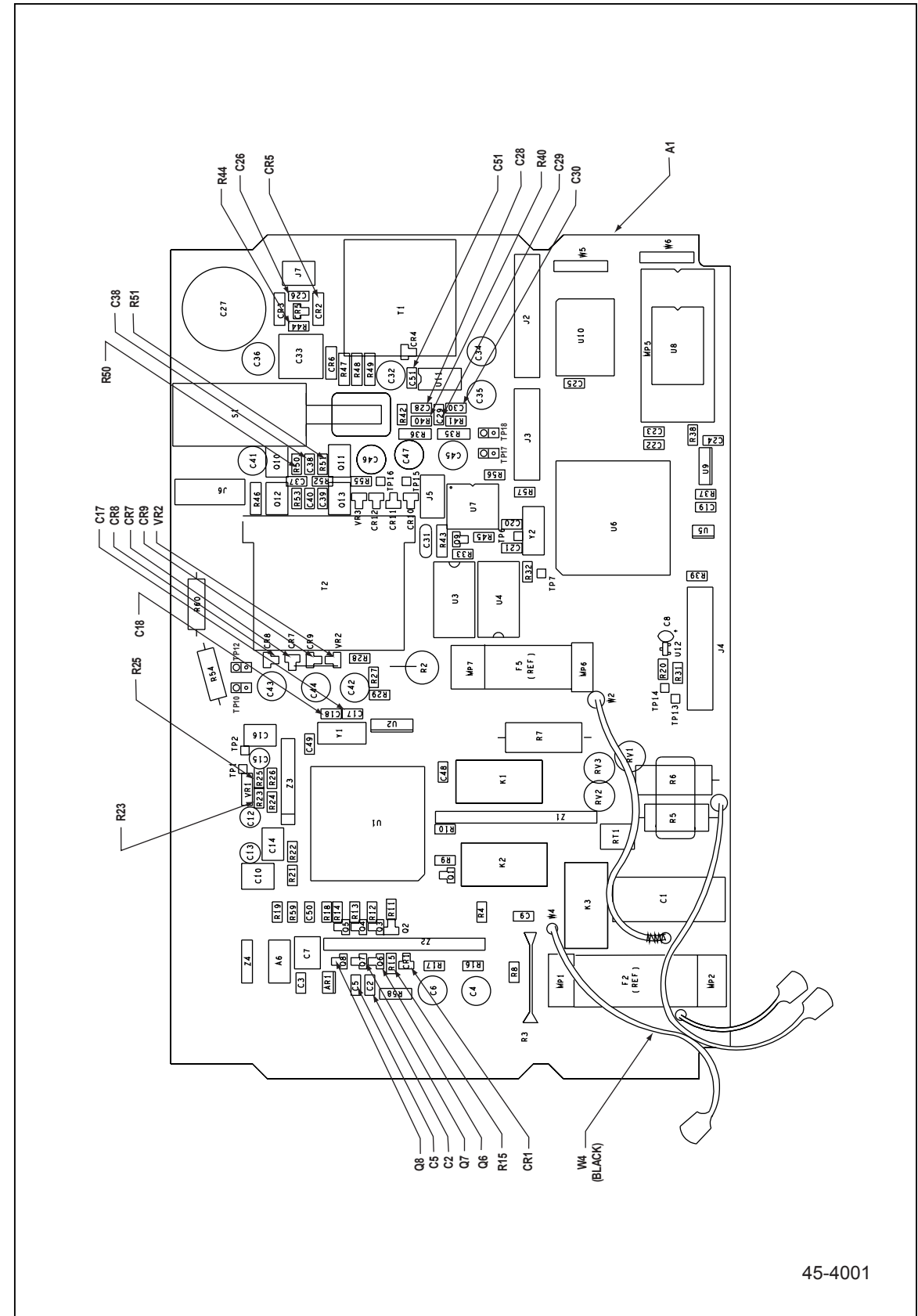
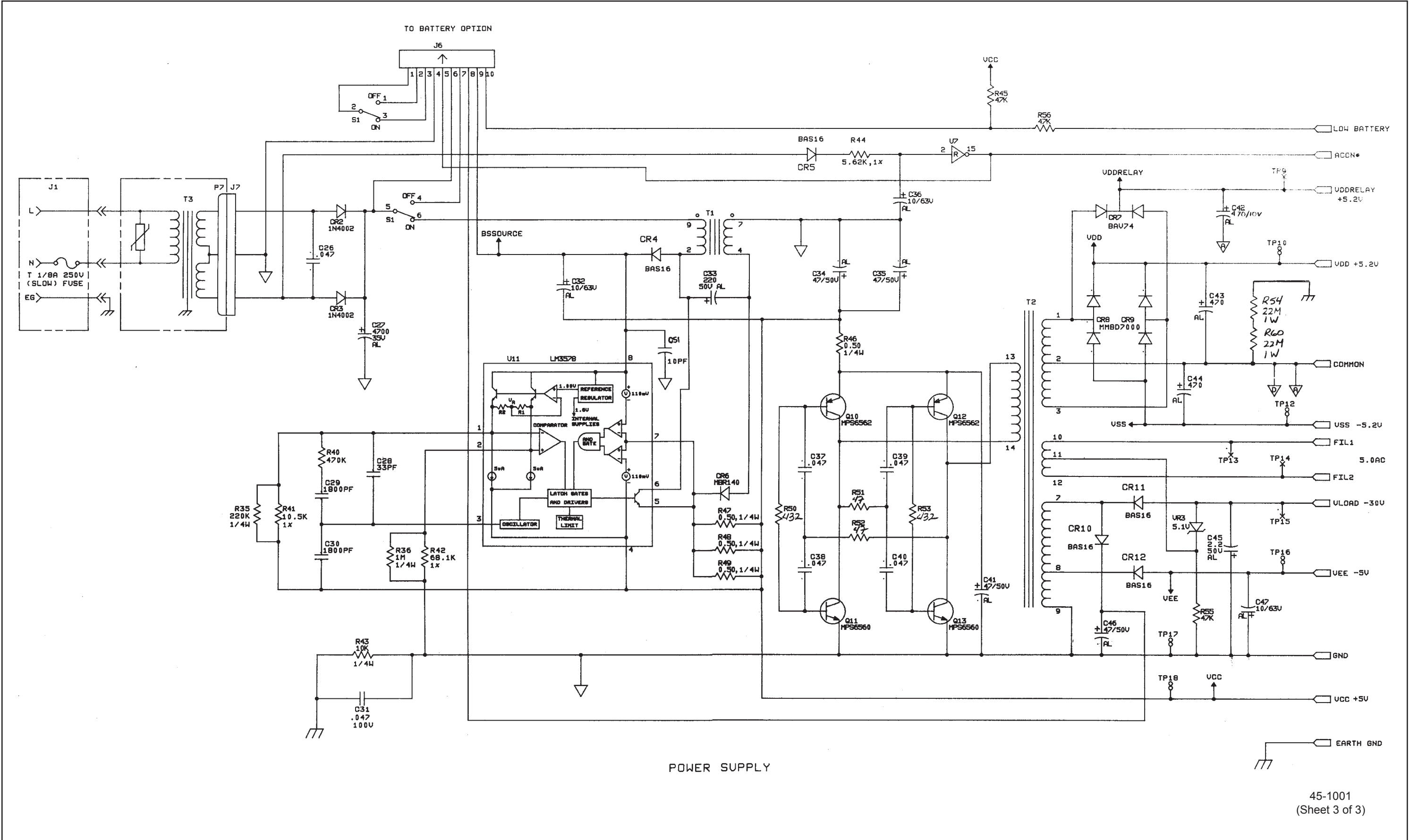
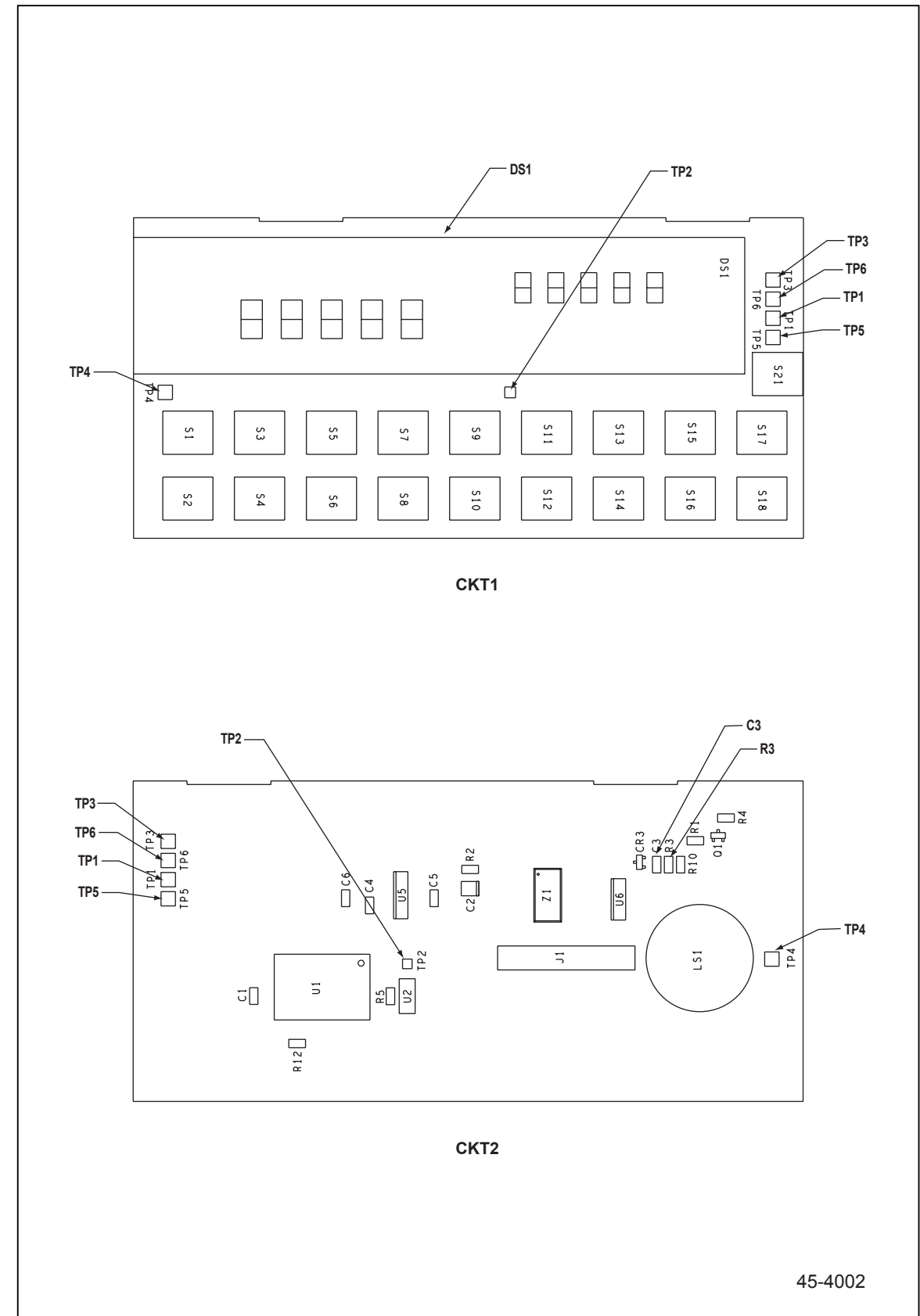

Figure 9-1. A1 Main PCA (cont)



45-1001
(Sheet 3 of 3)

Figure 9-1. A1 Main PCA (cont)



45-4002

Figure 9-2. A2 Display PCA

NOTES: UNLESS OTHERWISE SPECIFIED
 1. ALL RESISTANCE IS IN OHMS.
 2. ALL CAPACITANCE IS IN MICRO-FARADS.

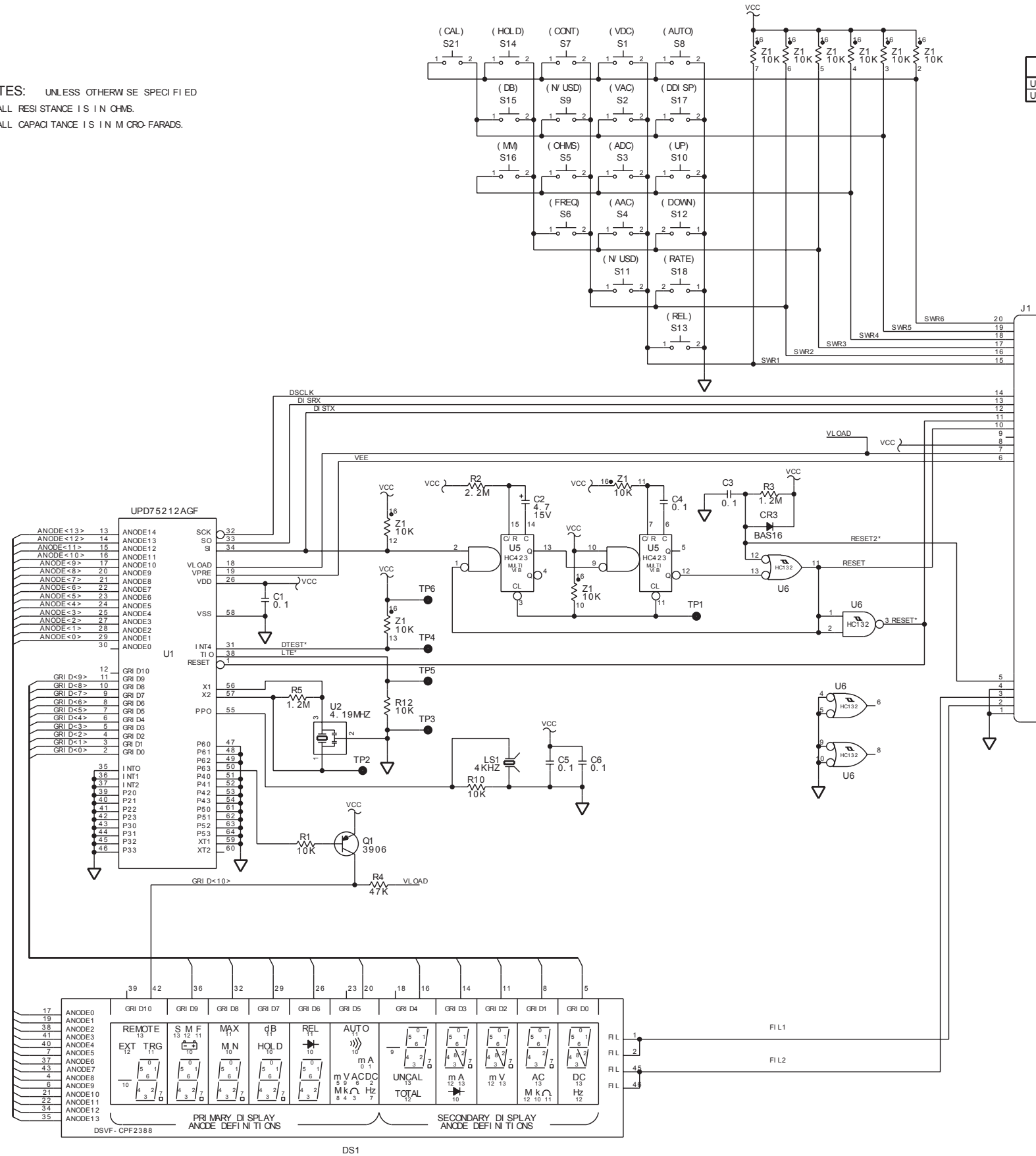

REF DES	PARTNAME	GND	VCC
U5	74HC423	8	16
U6	74HC132	7	14

REFERENCE DESIGNATOR	
LAST USED	NOT USED
C6	CR1, 2
CR3	
DS1	
J1	
LS1	
Q1	
R12	R6- 9, 11
S21	S19, 20
TP6	
U6	U3, 4
Z1	

45-1002

Figure 9-2. A2 Display PCA (cont)

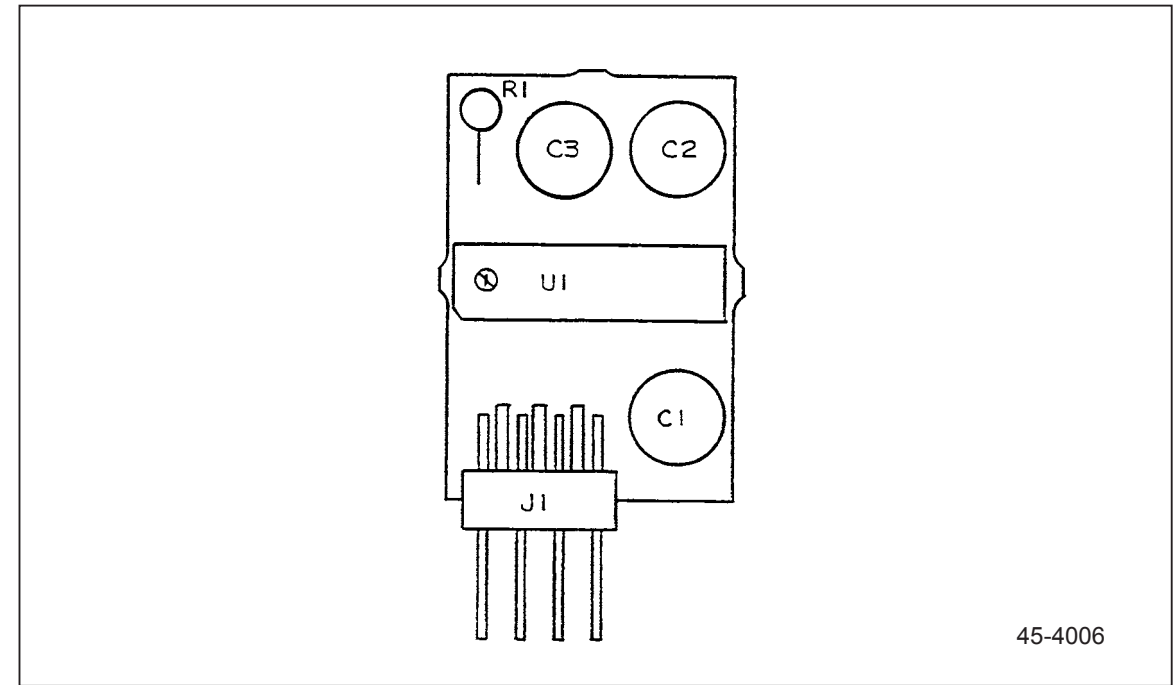

45-4006

Figure 9-3. A1A1 True rms PCA

NOTES: UNLESS OTHERWISE SPECIFIED

1. ALL RESISTANCES ARE IN OHMS, 1/8 WATT, +/-5%.
2. ALL CAPACITANCES ARE IN MICROFARADS.

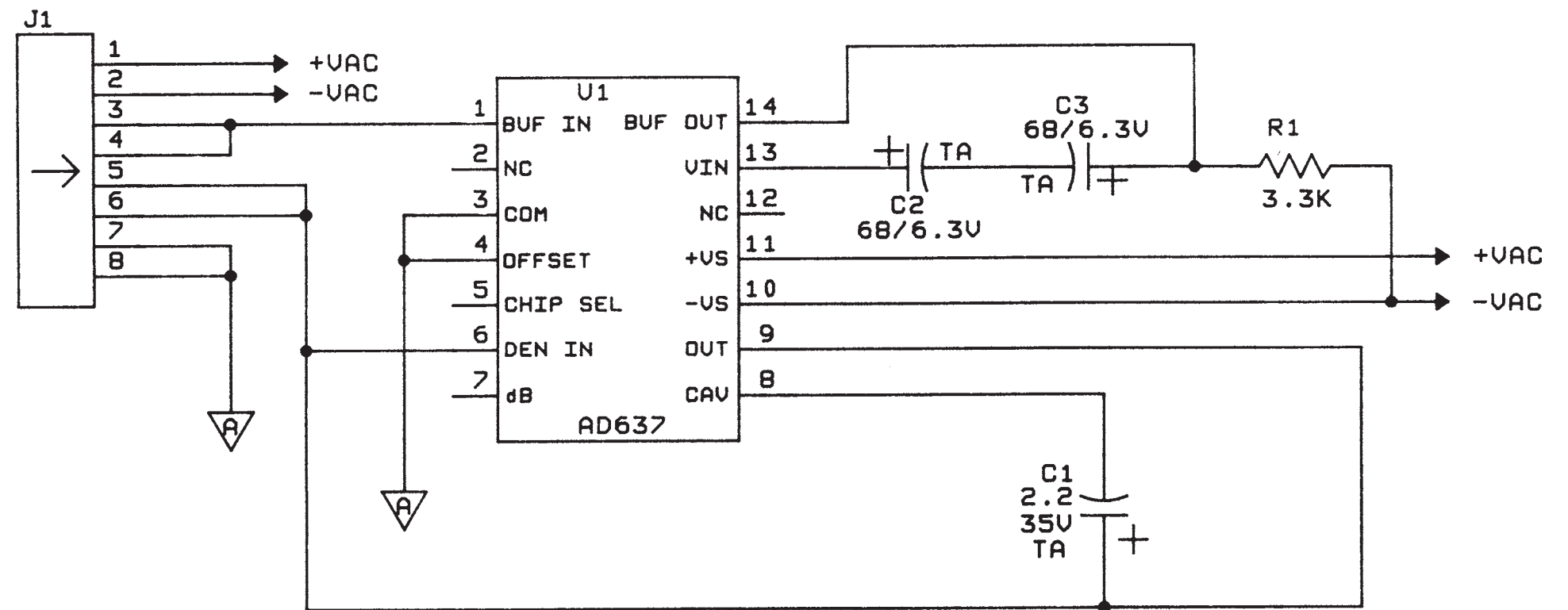

LAST USED	NOT USED
C3	
J1	
R1	
U1	

45-1006

Figure 9-3. A1A1 True rms PCA (cont)

qb49sc.tif

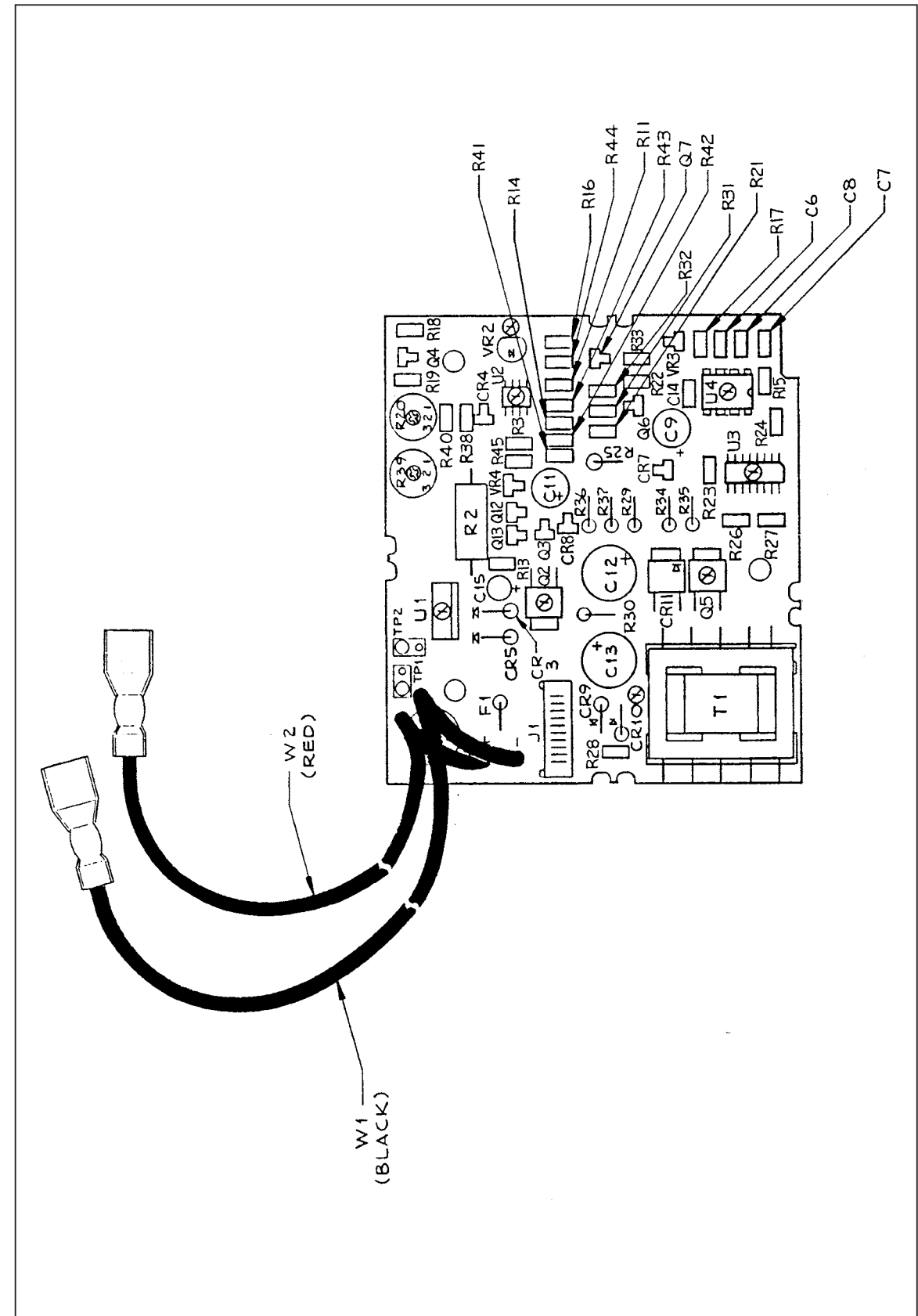
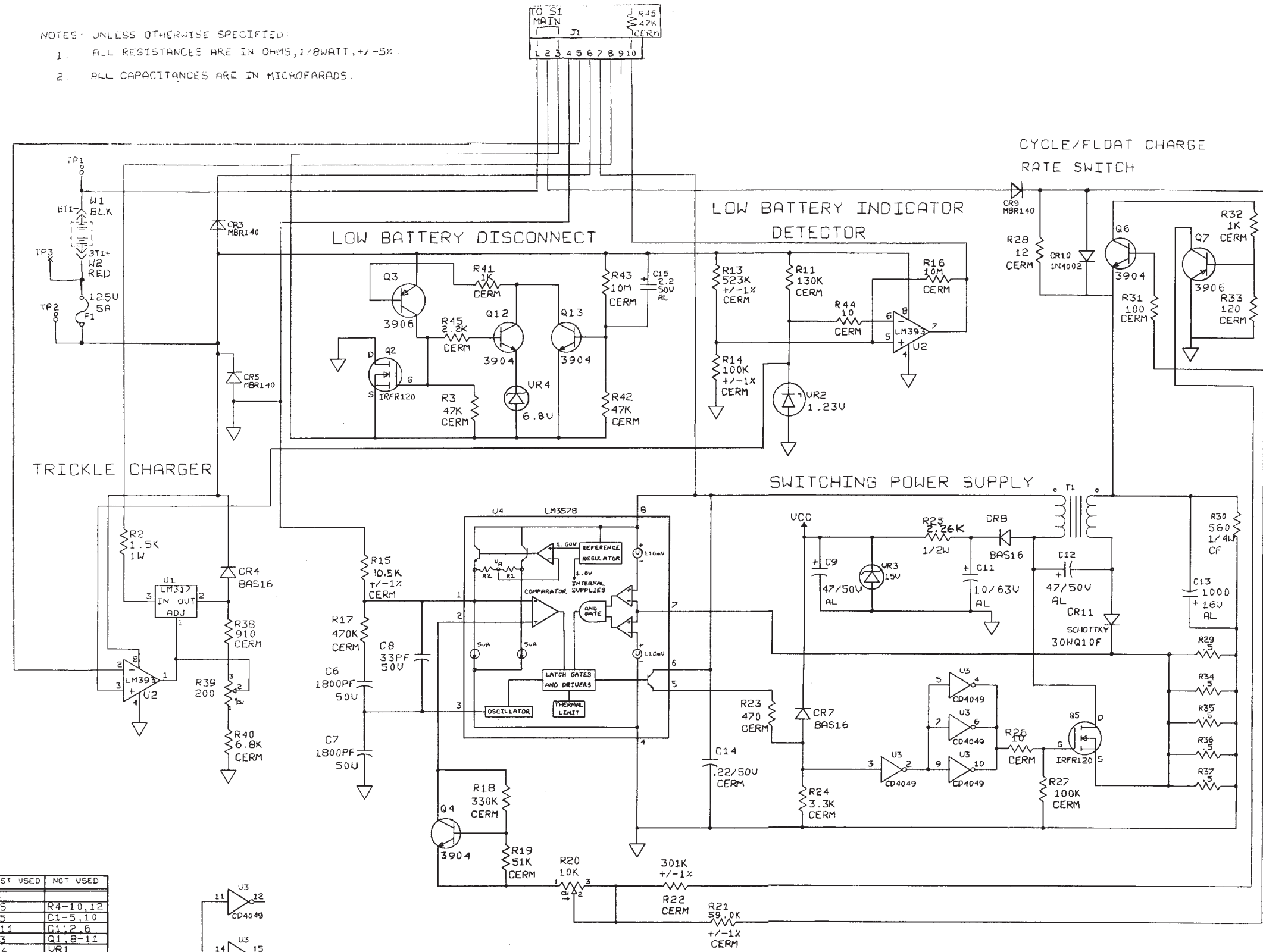
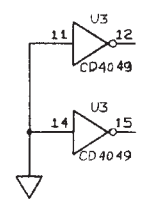

Figure 9-4. A4 Battery PCA

NOTES: UNLESS OTHERWISE SPECIFIED:
 1. ALL RESISTANCES ARE IN OHMS, 1/8WATT, +/-5%
 2. ALL CAPACITANCES ARE IN MICROFARADS



LAST USED	NOT USED
U4	R4-10, 12
R45	C1-5, 10
C15	CR1, 2, 6
CR11	Q1, 8-11
Q13	UR1
UR4	
J1	
T1	
E2	
TP3	



45-1004

Figure 9-4. A4 Battery PCA (cont)

qb53sc.tif

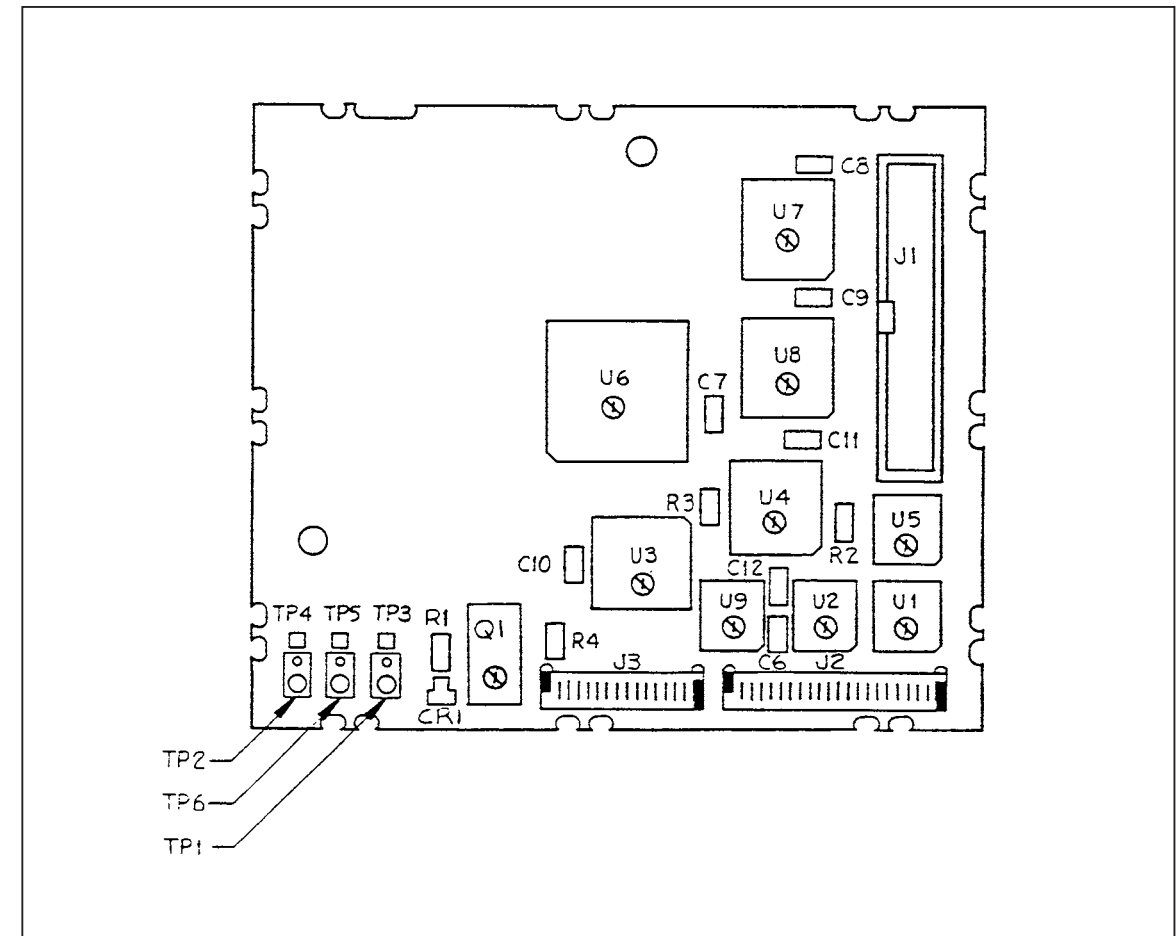
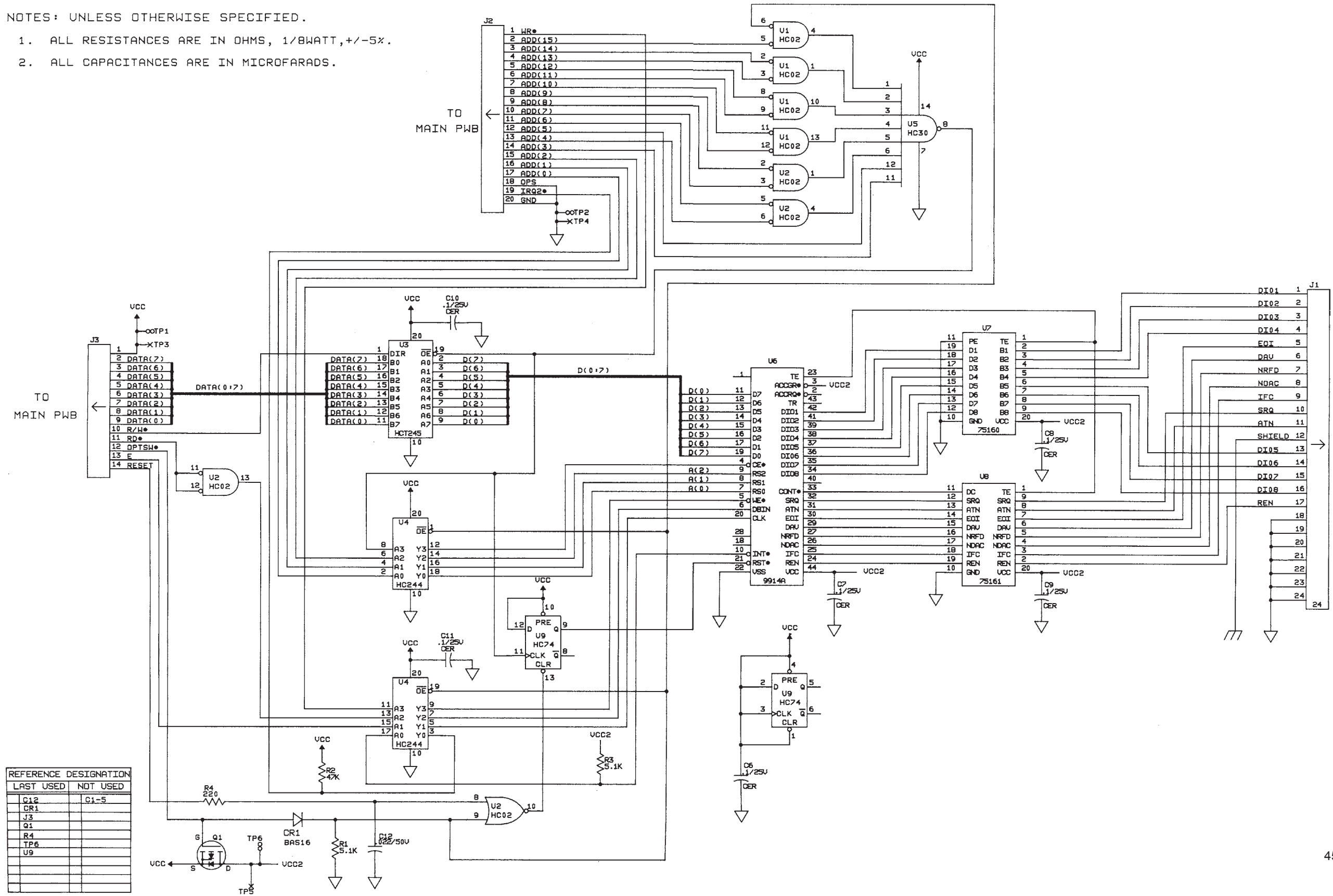

Figure 9-5. A5 IEEE-488 Interface PCA

NOTES: UNLESS OTHERWISE SPECIFIED.

1. ALL RESISTANCES ARE IN OHMS, 1/8WATT, +/-5%.
2. ALL CAPACITANCES ARE IN MICROFARADS.



45-1005

Figure 9-5. A5 IEEE-488 Interface PCA (cont)

qb54sc.tif

Index

—1—

100 m Ω and 300 m Ω ranges, 2-14

—5—

5-volt switching supply, 2-6, 5-11

—A—

a/d converter, 2-17
ac volts, 2-14
ac volts calibration (computer interface), 4-19
ac volts calibration (front panel), 4-9
ac volts troubleshooting, 5-14
acma, 2-15
active filter, 2-16
additional tests, 7-14
address decoding circuit, 8-3
alternate ohms calibration (computer interface), 4-20
alternate ohms calibration (front panel), 4-13
amps, 2-15
analog measurement processor, 2-3, 2-7
analog troubleshooting, 5-13
analog-to-digital (a/d) converter, 2-3
assemble the front panel assembly, 3-12
assembly procedures, 3-10

—B—

battery pack option (-01), 2-5
beeper drive circuit, 2-21

—C—

calibration, 7-12
calibration failures, 5-19

calibration interrelationships, 5-21
calibration using the computer interface, 4-15
calibration-related components, 5-20
cleaning, 3-4
communication problems, 8-10
concluding calibration using the computer interface, 4-20
constant voltage trickle charger, 7-6
continuity/hysteresis threshold calibration (computer interface), 4-20
continuity/hysteresis threshold calibration (front panel), 4-13
conventions, 1-5
current input fuses, 3-4
cycle/float charge rate switch, 7-5
cycle/float charge rate switch test, 7-10

—D—

dc and ac amps calibration (computer interface), 4-19
dc and ac amps calibration (front panel), 4-11
dc and ac milliamp calibration (front panel), 4-9
dc and ac milliamps calibration (computer interface), 4-19
dc volts, 2-12
dc volts calibration (computer interface), 4-19
dc volts calibration (front panel), 4-9
dc volts troubleshooting, 5-14
detailed circuit description, 2-5, 8-3
digital kernel, 2-5, 2-18
digital troubleshooting, 5-15
diode/continuity test, 2-15
disassembly procedures, 3-7
disconnect miscellaneous chassis components, 3-10
display, 2-21
display assembly, 2-5, 2-20

display assembly troubleshooting, 5-17
display controller with FIP, 2-22

—E—

editing the prompt for different calibration points, 4-14
eeprom, 2-19
entering calibration mode, 4-8
error codes, 5-4
exiting calibration mode, 4-9

—F—

failure to enter remote, 8-11
failure to generate a service request (srq), 8-12
failure to generate an end or identify (eoi), 8-12
failure to handshake on ieee-488 bus, 8-11
failure to receive multiple character commands, 8-12
failure to select ieee-488 option, 8-10
failure to transmit query responses, 8-12
frequency, 2-15
frequency calibration (computer interface), 4-20
frequency calibration (front panel), 4-13
front panel calibration, 4-7
front panel switches, 2-20
functional block description, 2-3, 7-3, 8-3
fuse test and replacement, 3-4

—G—

general maintenance, 7-6, 8-8
general maintenance information, 3-3
general operability, 7-9
general troubleshooting procedures, 5-10

—H—

how to contact fluke, 6-4
how to obtain parts, 6-3

—I—

ieee-488 controller, 8-4
ieee-488 interface, 4-16
ieee-488 option (-05), 2-5
ieee-488 option connections, 2-20
ieee-488 transceivers/connector, 8-5
input protection, 2-10
input protection circuit, 2-3
input signal conditioning, 2-3, 2-10
install miscellaneous chassis components, 3-10
install the analog measurement processor shields, 3-11
install the battery option, 3-11
install the front panel assembly, 3-15
install the handle and mounting brackets, 3-15

install the ieee-488 option, 3-12
install the main pca, 3-11
install the meter case, 3-15
install the rms pca, 3-11
installation, 7-7
installing the ieee-488 option, 8-9
inverter, 2-7, 5-12
isolation circuits, 8-4

—L—

line fuse, 3-4
list of replaceable parts, 7-14, 8-12
low battery disconnect, 7-5
low battery indicator detector, 7-5
low battery indicator detector and low battery disconnect test, 7-10

—M—

main assembly connector, 2-20
main assembly connectors, 8-3
manual status information, 6-4
microprocessor, 2-19

—N—

newer instruments, 6-4

—O—

ohms, 2-12
ohms calibration (computer interface), 4-19
ohms calibration (front panel), 4-11
ohms troubleshooting, 5-14
operating instructions, 1-3
options and accessories, 1-3
organization of the service manual, 1-4
other circuits, 7-6

—P—

performance testing, 7-9, 8-9
performance tests, 4-4
power requirements, 3-3
power supply, 2-3
power supply circuit description, 2-5
power supply troubleshooting, 5-10
power-up problems, 8-10

—R—

ram, 2-20
raw dc supply, 2-6, 5-10
relays, 2-11
removal, 7-6
remove handle and mounting brackets, 3-7

remove the analog measurement processor shields, 3-9
remove the battery option, 3-10
remove the display pca, 3-8
remove the front panel assembly, 3-8
remove the ieee-488 option, 3-9
remove the main pca, 3-9
remove the meter case, 3-7
remove the rms pca, 3-10
removing the ieee-488 option, 8-8
replacing the 10 a input fuse, 3-6
replacing the 100 ma input fuse, 3-5
required equipment, 3-3, 4-3
retrieving calibration constants, 5-21
rom, 2-20
rs-232 interface, 2-19, 4-15

—S—

schematic diagram, 7-14, 8-12
serial communication (guard crossing), 2-3, 2-18
servicing surface-mount assemblies, 5-3

setup, 4-15
specifications, 1-6, 7-3
Specifications, 1-6
static safe handling, 3-3
switching power supply, 7-5

—T—

testing current input fuses, 3-4
the calibration procedure, 4-18
theory of operation, 7-3, 8-3
troubleshooting, 7-13, 8-10

—U—

uart test, 5-13

—W—

warranty repairs and shipping information, 3-3
watchdog timer and reset circuit, 2-21

