

## Errata

**Title & Document Type: 8340A/B and 8341A/B Attenuator Calibration Operating Manual**

**Manual Part Number: 08340-90307**

**Revision Date: 1996-08-01**

---

### HP References in this Manual

This manual may contain references to HP or Hewlett-Packard. Please note that Hewlett-Packard's former test and measurement, semiconductor products and chemical analysis businesses are now part of Agilent Technologies. We have made no changes to this manual copy. The HP XXXX referred to in this document is now the Agilent XXXX. For example, model number HP8648A is now model number Agilent 8648A.

### About this Manual

We've added this manual to the Agilent website in an effort to help you support your product. This manual provides the best information we could find. It may be incomplete or contain dated information, and the scan quality may not be ideal. If we find a better copy in the future, we will add it to the Agilent website.

### Support for Your Product

Agilent no longer sells or supports this product. You will find any other available product information on the Agilent Test & Measurement website:

[www.tm.agilent.com](http://www.tm.agilent.com)

Search for the model number of this product, and the resulting product page will guide you to any available information. Our service centers may be able to perform calibration if no repair parts are needed, but no other support from Agilent is available.

**HP 8340A/B and  
HP 8341A/B  
ATTENUATOR CALIBRATION  
AND OPERATION VERIFICATION  
TEST SOFTWARE**

**For the HP 8340A/B and 8341A/B  
Synthesized Sweepers**

Pub Number 08340-90307  
August 1986



**HEWLETT  
PACKARD**

# **HP 8340A/B AND HP 8341A/B ATTENUATOR CALIBRATION AND OPERATION VERIFICATION TEST SOFTWARE**

**REVISION A.02.00**

This manual applies directly to the HP 8340A/B and HP 8341A/B Attenuator Calibration and Operation Verification Test Software, HP Part Number 08340-10009, revision A.02.00.

©Copyright                      HEWLETT-PACKARD COMPANY                      1986  
1400 FOUNTAINGROVE PARKWAY, SANTA ROSA, CA 95401 U.S.A.

MANUAL PART NO. 08340-90307  
Microfiche Part Number 08340-90308

Printed: AUGUST 1986



## WARRANTY

This Hewlett-Packard instrument product is warranted against defects in material and workmanship for a period of one year from date of delivery. During the warranty period, Hewlett-Packard Company will, at its option, either repair or replace products which prove to be defective.

For warranty service or repair, this product must be returned to a service facility designated by HP. Buyer shall prepay shipping charges to HP and HP shall pay shipping charges to return the product to Buyer. However, Buyer shall pay all shipping charges, duties, and taxes for products returned to HP from another country.

HP warrants that its software and firmware designated by HP for use with an instrument will execute its programming instructions when properly installed on that instrument. HP does not warrant that the operation of the instrument, or software, or firmware will be uninterrupted or error free.

## LIMITATION OF WARRANTY

The foregoing warranty shall not apply to defects resulting from improper handling by Buyer, Buyer-supplied software or interfacing, unauthorized modification or misuse, or operation outside of the environmental specifications for the product.

NO OTHER WARRANTY IS EXPRESSED OR IMPLIED, HP SPECIFICALLY DISCLAIMS THE IMPLIED WARRANTIES OR MERCHANTABILITY AND FITNESS FOR A PARTICULAR PURPOSE.

## EXCLUSIVE REMEDIES

THE REMEDIES PROVIDED HEREIN ARE BUYER'S SOLE AND EXCLUSIVE REMEDIES, HP SHALL NOT BE LIABLE FOR ANY DIRECT, INDIRECT, SPECIAL, INCIDENTAL, OR CONSEQUENTIAL DAMAGES, WHETHER BASED ON CONTRACT, TORT, OR ANY OTHER LEGAL THEORY.

## ASSISTANCE

*Product maintenance agreements and other customer assistance agreements are available for Hewlett-Packard Products.*

*For any assistance, contact your nearest Hewlett-Packard Sales and Service Office. Addresses are provided at the back of this manual.*

# TABLE OF CONTENTS

<b>CHAPTER 1 General Information</b> .....	1	<b>CHAPTER 8 Calibration Constants Utility</b> .....	25
1.0 Introduction		8.0 Description	
1.1 Format of the Disc Containing the Software		8.1 Test Equipment	
1.2 Test Capability		8.2 Procedure	
1.3 Test Record		<b>CHAPTER 9 Phase Lock Diagnostics</b> .....	27
1.4 Make a Copy Before Use		9.0 Description	
1.5 Anomaly Reporting		9.1 Test Equipment	
1.6 Software Support Information		9.2 Procedure	
<b>CHAPTER 2 Required Test Equipment</b> .....	3	<b>CHAPTER 10 CW Frequency Accuracy Test</b> .....	29
2.0 Introduction		10.0 Description	
2.1 Technical Computer		10.1 Test Equipment	
2.2 Disc Drive		10.2 Procedure	
2.3 Operating System		<b>CHAPTER 11 ALC Accuracy Verification</b> .....	31
2.4 Test Equipment		11.0 Description	
<b>CHAPTER 3 How to Configure the Software</b> .....	7	11.1 Test Equipment	
3.0 Introduction		11.2 Procedure	
3.1 Mass Storage and Data Storage Requirements		<b>CHAPTER 12 Output Power Accuracy Test</b> .....	33
3.2 Mass Storage and Data Storage Addressing		12.0 Description	
3.3 Modifying Mass Storage and Data Storage Addressing		12.1 Test Equipment	
3.4 HP-IB Addresses of the Test Equipment		12.2 Procedure	
3.5 Modifying the HP-IB Addresses of the Test Equipment		<b>CHAPTER 13 Maximum Levelled Output Power Test</b> .....	35
<b>CHAPTER 4 Test Dependency</b> .....	15	13.0 Description	
4.0 Introduction		13.1 Test Equipment	
4.1 Test Dependency Flow Chart		13.2 Procedure	
<b>CHAPTER 5 Running the Software</b> .....	17	<b>CHAPTER 14 RF Attenuator Calibration</b> .....	37
5.0 Introduction		14.0 Description	
5.1 System Setup		14.1 Test Equipment	
5.2 Booting Up the Software		14.2 Procedure	
<b>CHAPTER 6 Running the Cal Utilities</b> .....	19	<b>CHAPTER 15 Frequency Switching Time Test</b> .....	41
6.0 Introduction		15.0 Description	
6.1 Entry of the IF Attenuator's Calibration Data		15.1 Test Equipment	
6.2 Entry of the Power Sensor's Calibration Data		15.2 Procedure	
6.3 10 MHz Calibration Procedure		<b>CHAPTER 16 Test Menu Utility Softkey</b> .....	43
<b>CHAPTER 7 Testing an HP 8340A/B or HP 8341A/B</b> .....	21	16.0 Description	
7.0 Introduction		16.1 Test Equipment	
7.1 Selecting the Type of Testing		16.2 Procedure	

# Chapter 1. General Information

---

## 1.0 Introduction

For your convenience, this supplement provides information to assist you in using the HP 8340A/B and 8341A/B Attenuator Calibration and Operation Verification Test Software, HP part number 08340-10009, provided with this document. The information begins with a general overview of the software, continues with the equipment required and modifications which can be made by the operator, and finally ends with how to run the tests.

## 1.1 Format of the Disc Containing the Software

The test software included with this documentation is being supplied on a double sided 3.5" microfloppy. Any access to or copying of the programs on the software disc requires the use of a double sided 3.5" microfloppy disc drive. Two examples of this type of disc drive are the 3.5" floppy drive in the HP 9133H and the 3.5" floppy drives in the HP 9122D.

## 1.2 Test Capability

The Attenuator Calibration and Operation Verification Test Software provides the capability to perform a semi-automated operation verification of the HP 8340A, 8341A, 8340B, and 8341B synthesized sweepers in addition to a complete calibration (adjust and test) of the 90 dB step attenuator included with many of the synthesizers.

The operation verification portion of the test software is intended to provide a 90% confidence level of the operation of the synthesizer. The operation verification is designed for use as an incoming inspection of the synthesizers or as a verification of instrument operation after an instrument repair. The performance tests provided in the operation verification are CW frequency accuracy, output power accuracy and flatness, and maximum leveled power. In addition, a phase lock loop diagnostic, an ALC accuracy verification, and a utility for displaying the internal calibration data are also provided.

The attenuator calibration portion of the test software provides the capability to adjust and verify the performance of the internal 90 dB step attenuator included with many of the synthesizers. In addition to this, a semi-automated performance test for the frequency switching time specification is provided. Both the 90 dB step attenuator adjustment and frequency switching time performance test can only be performed using the automated test supplied with this software. These tests should be used to supplement the manual adjustments and tests provided in the HP 8340A, 8341A, 8340B and 8341B operating and service manuals.

## 1.3 Test Record

Depending on the test which is performed, the test results will be presented in either tabular or graphical form. The test data includes test limits and the instrument's performance. During the testing, the operator is given a choice of either outputting the test data to the CRT of the system computer or to an external printer. Printed copies of the test data may be used as a permanent test record.

## 1.4 Make a Copy Before Use

Before running the test software or making any changes to the software's configuration, you should make a copy of the master disc supplied with this documentation. The master should then be stored in a safe place and the copy used for daily testing.

In order to make a copy of the master disc, you will need either two double sided 3.5" microfloppy disc drives or one fixed disc drive and one double sided 3.5" microfloppy disc drive. Two disc drives which may be used are the HP 9133H or the HP 9122D. In addition, the media on which the copy is made must be capable of storing the entire software (i.e., either another double sided 3.5 inch floppy or a fixed disc). The storage space requirements for this revision of software is approximately 650 kbytes.

When copying the software onto another 3.5 inch, double sided microfloppy, you must first initialize your blank floppy. When initializing your floppy, you must specify the interleave factor and also the format to be used during initialization. The required interleave factor is 2 and the required format is 3 (1024 bytes/sector). The initialize command you would execute from your computer's keyboard is as follows:

*INITIALIZE "Address of the disc drive containing your blank floppy",2,3*

An example would be: *INITIALIZE ":",700,1",2,3*. This would initialize a disc at HP-IB address 700, drive 1 and would set the disc's interleave factor to 2 and format to 1024 bytes/sector. If you do not initialize your blank 3.5 inch, double sided microfloppy in this manner, you will not have sufficient space on the disc to copy the software!

For your convenience, a copy program has been included on the master disc supplied with this document. This program allows you to copy the files on the master disc to either an initialized fixed disc or another 3.5" double sided floppy. When copying the master to another 3.5" floppy, insert the master disc into drive 0 of your double sided 3.5" disc drive and insert an initialized 3.5" floppy into drive 1. The name of the copy program is "Copy". After your floppy has been initialized, load the copy program "Copy" from the master disc and respond to the prompts provided. To ensure that you do not erase the programs on the master disc, you should Write Protect the master.

## 1.5 Anomaly Reporting

As with all software, an anomaly may occur. Notify the nearest Hewlett-Packard sales and service office when a software anomaly is observed. Use the software notification form located at the end of this manual.

## 1.6 Software Support Information

The software support provided by Hewlett-Packard for the HP 8340A/B and HP 8341A/B Attenuator Calibration and Operation Verification Test Software, HP P/N 08340-10009, is limited to the correction of anomalies found while using this test software with the test equipment recommended in Chapter 2 of this document. Any deviation from the equipment recommended in Chapter 2 will not be supported by Hewlett-Packard. In addition, the software modifications which the operator is allowed to perform is limited to the mass storage address, data storage address, and the test equipment address modifications described in Chapter 3 of this document. Modifications made to the software beyond those described in Chapter 3 will not be supported by Hewlett-Packard.

## Chapter 2. Required Test Equipment

---

### 2.0 Introduction

This chapter provides a description of the test equipment and operating system requirements for the attenuation calibration and operation verification test software.

### 2.1 Technical Computer

Technical Computer: HP 9836A (HP 236) with > 1 megabyte of memory.

The Attenuator Calibration and Operation Verification software is also directly compatible with the HP 9816 (HP 216) and HP 9826 (HP 226) technical computers provided they also have > 1 megabyte of memory.

If you wish to use an HP 9000 Series 300 computer, the Attenuator Calibration and Operation Verification Software is compatible with the HP 98580A Option 008 system. This system includes an HP Model 310 (with 1 megabyte of memory), a 35731A monochrome monitor, a 46020A keyboard, Basic 4.0, and the 98546A video board for Series 200 display compatibility.

### 2.2 Disc Drive

Disc Drive: HP 9133H or HP 9122D

The critical requirements of the disc drive used to run the Attenuator Calibration and Operation Verification Software is that the disc drive media be capable of storing > 650 kbytes of information on one disc and that the disc drive is compatible with the HP 9000 Series 200 or Series 300 technical computer you are using.

The HP 9122D is recommended because of its low cost and the convenience provided by the dual, double sided 3.5" floppy disc drives. The HP 9122D provides full compatibility with the Attenuator Calibration and Operation Verification Software in addition to the convenience of running the test software and storing the test data on the same type of media. The HP 9122D also simplifies the task of making a working copy of the test software.

The HP 9133H is recommended because it provides additional storage capability for other software you may have, allows convenient storage of the test data on either the fixed disc or a 3.5" floppy and also simplifies the task of making a working copy of the test software.

For some additional information regarding mass storage and data storage requirements, refer to paragraph 3.1.



## 2.3 Operating System

Operating System: **HP Basic 3.0** and the HP Basic 3.0 binary extensions listed below or **HP Basic 4.0** and the HP Basic 4.0 binary extensions listed below. If you are using the Series 300 computer recommended in paragraph 2.1, you must use HP Basic 4.0.

Name	Description
GRAPH	Graphics
GRAPHX	Graphics Extensions
IO	I/O
MAT	Matrix Statements
KBD	Keyboard Extensions
CLOCK	Clock
MS	Mass Storage
ERR	Error Messages
CS80	CS80 Disc Driver
HPIB	HP-IB Interface Driver

Note that when HP Basic 3.0 or 4.0 is loaded into your technical computer's memory, the binary extensions must also be loaded. The binary extensions can either be loaded by using the "LOAD BIN" command or by configuring your HP Basic 3.0 or 4.0 operating system to include the binary extensions (this is the most convenient way). For more information regarding configuring an operating system, refer to your HP Basic 3.0 or 4.0 User's Guide under the heading "Configuring Basic Systems".

## 2.4 Test Equipment

Local Oscillator <sup>1</sup>	HP 8340A Option H01 or HP 8340A/B Option 001
Spectrum Analyzer <sup>1</sup>	HP 3585A
Frequency Counter <sup>2</sup>	HP 5343A Option 011
Power Meter	HP 436A Option 022
Power Sensor	HP 8481A
Power Sensor	HP 8485A
Universal Counter <sup>1</sup>	HP 5316A
Amplifier <sup>1</sup>	HP 8447F
Step Attenuator (calibrated at 1 MHz) <sup>1</sup>	HP 355D
Printer	HP 2673A or HP 2225A
Attenuator (10 dB) <sup>1</sup>	HP 8493C Option 010
Attenuator (20 dB)	HP 8493C Option 020
Mixer <sup>1</sup>	HP P/N 0955-0307
Low Pass Filter <sup>1</sup>	HP P/N 9135-0260

1. Required for the Attenuator Calibration Tests only.

2. Required for the Operation Verification Tests only.

Adapters:

APC 3.5 (f) to APC 3.5 (f) (2 required)	HP P/N 5061-5311
APC 3.5 (f) to Type N (m)	HP P/N 1250-1744
APC 3.5 (f) to Type N (f) <sup>3</sup>	HP P/N 1250-1745
SMA (m) to BNC (f)	HP P/N 1250-1200
Type N (m) to BNC (f) <sup>2</sup>	HP P/N 1250-0780

Cables:

Semi-rigid coax, SMA(m) to SMA (m)	HP P/N 08340-20124
BNC (m) to BNC (m) (7 required)	HP P/N 8120-1840
3.5 inch Diskettes (Box of 10)	HP 92192A

In addition, a minimum of 5 HP-IB cables will be required to run the tests (includes connection to disc drive and printer).

- 
1. Required for the Attenuator Calibration Tests only.
  2. Required for the Operation Verification Tests only.
  3. Required for testing an HP 8340A/B only.

# Chapter 3. How to Configure the Software

---

## 3.0 Introduction

This chapter describes the mass storage and data storage requirements, addressing, and the modifications which are allowed for configuring the software to match you mass storage and data storage devices. Also described is the HP-IB addressing of the test equipment and what modifications can be made.

## 3.1 Mass Storage and Data Storage Requirements

Mass storage in this document refers to the storage location of the test software and the location of the user generated calibration data files (described in Chapter 6). The test software includes all of the program files and data files supplied on the Attenuator Calibration and Operation Verification disc (with the exception of "Copy"). The total mass storage requirement is 650 kbytes. With this mass storage requirement, the disc drives which may be used are limited to a double sided 3.5" microfloppy disc drive (700 kbytes storage capability per floppy disc) or a fixed disc drive with > 650 kbytes of storage capability.

Data storage in this document refers to the storage location of the test result data files. All of the tests (with the exception of CW frequency accuracy and loop thrasher) store the test result data onto the designated data storage device. The data storage requirements per instrument is approximately 15 kbytes.

## 3.2 Mass Storage and Data Storage Addressing

The software comes configured for immediate use on an HP 9122D which is set to HP-IB address 700 or on an HP 9133H which is configured for one volume and is set to HP-IB address 700. With either of these disc drives, the mass storage device is drive 0 and the data storage device is drive 1. For your convenience, the appropriate switch settings and some other additional information about the disc drive configuration is provided in the next two paragraphs.

**HP 9122D** – Set to HP-IB address 700 (the HP 9122D's HP-IB DIP switch is set up with switch 1 up and switches 2, 3, and 4 down). When using the HP 9122D, the test software disc is placed in drive 0 (left hand drive, HP-IB address ":",700,0") and an initialized disc, which will be used for test data storage, is placed in drive 1 (right hand drive, HP-IB address ":",700,1").

**HP 9133H** – Set to HP-IB address 700 (make sure the thumbwheel on the rear panel is set to 0). Set the HP 9133H's rear panel configuration dial to 0 or 1. Make sure the hard disc drive (drive 0) is initialized and has either HP BASIC 3.0 or 4.0 loaded along with the binary extensions mentioned earlier. As mentioned in paragraph 2.3, Operating System, the binary extensions should be part of the HP Basic 3.0 or 4.0 operating system. When using the HP 9133H, the test software is located in drive 0 (fixed disc drive, HP-IB address ":",700,0") and an initialized disc, which will be used for test data storage, is placed in drive 1 (floppy disc drive, HP-IB address ":",700,1"). For more information regarding the initialization and addressing of the HP 9133H, refer to the "Using Your HP 9133H Disc Drive" manual supplied with the HP 9133H. The chapter you need to refer to is Using Your HP 9133H With Series 200 BASIC 3.0.

The software comes already configured for either of the disc drives listed above (provided the disc drive settings are as shown). If you wish to use a different HP-IB address for the disc drive or select a different number of volumes on the HP 9133H (above configuration dial setting selects one volume), you must modify a few lines of code in the software in order for the software to run. Paragraph 3.3 provides the details on modifying the software. If you use the settings listed above, no modification is required.

### 3.3 Modifying Mass Storage and Data Storage Addressing

Six system variables located in the overhead program FS\_MANAGER, subprogram Mass\_stg\_init, are used to define three addresses (storage locations); one address for the test software, one for the test result data files, and one for the user generated calibration data files (described in Chapter 6). Each address requires two system variables; the first system variable is used for the directory pointer and the second for the mass storage unit specifier. Table 1 lists the six system variables, what address they define, and what type of system variable they are. Figure 1 provides a listing of the subprogram Mass\_stg\_init which shows the current configuration of the system variables and their location. The balance of this section describes the use of the directory pointer and the mass storage unit specifier in this software and should give some insight as to what changes would need to be made to the system variables to accommodate different storage media. The descriptions supplied assume that you are familiar with the operation of your disc drive. Before making any changes, you should read through the directory pointer and mass storage unit specifier descriptions in this section and determine what modifications need to be made. When you are ready to perform the modification, you should then read PERFORMING THE MODIFICATION at the end of this section.

Table 1. System Variables

Name	Address Defined	System Variable Type
Manager_sys\$	Test Software	Directory Pointer
Msus\$	Test Software	Mass Storage Unit Specifier
Dut_dir\$	Test Result Data Files	Directory Pointer
Dut_msus\$	Test Result Data Files	Mass Storage Unit Specifier
Calfactor_dir\$	Calibration Data Files	Directory Pointer
Cf_msus\$	Calibration Data Files	Mass Storage Unit Specifier

#### DIRECTORY POINTER DESCRIPTION

The following describes the use of the directory pointer in the test software. Although Manager\_sys\$ is referred to specifically, the description regarding the usage of the directory pointer applies to all three directory pointers.

Manager\_sys\$ defines the directory pointer for the test software. Since the HP 9133H and 9122D do not use directories for organizing information on the disc, the directory pointer, Manager\_sys\$, is set to the null string in the program (i.e., Manager\_sys\$=""). For a disc drive which uses directories and thus requires the directory pointer to be defined, Manager\_sys\$ should be changed to reflect the label of the directory where the test software is stored.

Example: Manager\_sys\$="/8340TEST/" or Manager\_sys\$="/APPLIC/8340TEST/").

Note that the slashes required for the directory pointer are included on both ends.

## MASS STORAGE UNIT SPECIFIER DESCRIPTION

The following describes the use of the mass storage unit specifier in the test software. Although Msus\$ is referred to specifically, the description regarding the usage of the mass storage unit specifier applies to all three mass storage unit specifiers.

Msus\$ is the mass storage unit specifier which defines the address for the test software. When using an HP 9133H set to one volume and HP-IB address 700 or an HP 9122D set to HP-IB address 700, Msus\$ would be set as follows: Msus\$="";,700,0". This designates drive 0 as the storage location for the test software. When using other disc drives or another address, you would need to set Msus\$ to reflect the address of your disc drive. Two examples could be; Msus\$="";REMOTE 21,3" (when using a shared resource management system) or Msus\$="";,700,0,0" (when using an HP 9133H set to more than one volume).

## PERFORMING THE MODIFICATION

After you have determined the modifications which need to be made to the system variables, you should perform the following.

1. Bootup HP Basic 3.0 or 4.0 with the appropriate binary extensions needed to operate your system. If using an HP 9133H or 9122D, the binary extensions listed in paragraph 2.3 are all you need.
2. LOAD "FS\_MANAGER".
3. EDIT Mass\_stg\_init.
4. Scroll to the system variables which need to be modified and make the appropriate changes. Enter each line after modifying.
5. Check the system variables to ensure that the modifications you made are correct.
6. If the storage media you are using for the test software is a double sided 3.5" microfloppy, you will need to PURGE "FS\_MANAGER".
7. RE-STORE "FS\_MANAGER".

```

1283 Mass_stg_init:!
1284 !-----!
1285 ! FIELD SERVICE VERSION -- assumes HP 9133H or HP 9122D
1286 !
1288 !-----!
1289 ! This subprogram must initialize the variables for a particular
1290 ! implementation of 'MANAGER'.
1291 !-----!
1292 COM /Mass_storage/ Manager_sys$,Menu_storage$
1293 COM /Mass_storage/ Dir_pointer$,Msus$
1294 COM /Dut_storage/ Dut_dir$[50],Dut_msus$[50]
1295 COM /Janitor_mode/ Jan_mode$[12]
1296 COM /Calfactor_strg/ Calfactor_dir$[50],Cf_msus$[30]
1297 COM /Config/ Mass_stg_sys$[30]
1298 COM /Enhancements/ On$[1],Off$[1],Flash$[1]
1299 COM /Keyboard/ INTEGER Hil_keyboard
1300 !
1301 ! Manager_sys$      Directory pointer for System program files.
1302 ! Menu_storage$    Directory pointer Menu files.
1303 ! Dir_pointer$     Directory pointer for Subsystem data files.(NOT USED)
1304 ! Msus$           Mass storage unit specifier for menu's and subsystems
1305 ! Dut_dir$        Directory pointer for DUT data files
1306 ! Dut_msus$       Mass storage specifier for DUT data files
1307 ! Calfactor_dir$  Directory pointer for test system cal files
1308 ! Cf_msus$        Mass storage specifier for cal files
1309 ! Mass_stg_sys$   Mass storage system specifier('HARD DISC' or 'FLOPPY')
1310 ! On$             Display enhancement to turn inverse video ON
1311 ! Off$            Display enhancement to turn enhancement OFF
1312 ! Flash$          Display enhancement to turn flashing ON
1313 !-----!
1314 Manager_sys$=""
1315 Menu_storage$=Manager_sys$
1316 Dir_pointer$=Manager_sys$
1317 Msus$=":,700,0"
1318 !
1319 Dut_dir$=""
1320 Dut_msus$=":,700,1"
1321 !
1322 Calfactor_dir$="Manager_sys$"
1323 Cf_msus$=Msus$
1324 !

```

Figure 1. Program Listing, Mass\_stg\_init

### 3.4 HP-IB Addresses of the Test Equipment

The Attenuator Calibration and Operation Verification test software has been written to drive specific HP-IB test equipment. Although the test equipment which is required can not be changed, the HP-IB addresses for the test equipment can be modified. Table 2 below lists the test equipment with HP-IB and the equipment's HP-IB addresses. Use of the HP-IB addresses shown below will not require any modification of the software. If you wish to use different addresses than shown, you will need to modify the software. For the HP-IB address modification procedure, refer to paragraph 3.5.

Table 2. HP-IB Address Settings for the Test Equipment

Model Number	Description	HP-IB Address
HP 2673A or 2225A	Printer	01
HP 5343A	Frequency Counter	02
HP 3585A	Spectrum Analyzer	11
HP 436A	Power Meter	13
HP 5316A	Universal Counter	16
HP 8340A/B or 8341A/B	Device Under Test	19
HP 8340A/B	Local Oscillator	20

### 3.5 Modifying the HP-IB Addresses of the Test Equipment

Located in the overhead program FS\_MANAGER, subprogram Asgn\_test equip, are the assignments of the HP-IB addresses for the test equipment used in the test software. Figure 2 provides a listing of the subprogram Asgn\_test equip and the current HP-IB address assignments. Included in the test equipment assignments are some additional pieces of test equipment which are not needed to run the HP 8340A/B and HP 8341A/B Attenuator Calibration and Operation Verification Test Software. You only need to modify the HP-IB address assignments for the test equipment listed in Table 2. The procedure for modifying the test equipment's HP-IB address assignments is described below in PERFORMING THE MODIFICATION.

```

3460 Asgn_test equip: !
3461 ! -----!
3462 ! This subprogram assigns addresses to the I/O path names in the
3463 ! /Hplib_codes/ common block.
3464 ! -----!
3465 COM /Hplib_codes/ @Dut,@Hfsa,@Lfsa,@Cntr,@Pwrmttr,@Dvm
3466 COM /Hplib_codes/ @Fun_gen,@Rf_gen,@Het,@Mod_an,@Atn_drv
3467 COM /Hplib_codes/ @Timer,@Pulse_gen,@Pwr_supply,@D15,@D16
3468 ! -----!
3469 COM /Peripherals/ INTEGER Prntr,Key_bd,Screen
3470 ! -----!
3471 COM /Equipment/ Dvm$[6],Mod_an$[6]
3472 ! -----!
3473 ASSIGN @Dut TO 719 ! HP 8340A OR 8341A UNDER TEST
3474 ASSIGN @Hfsa TO 718 ! HP 8566A OR 8566B SPECTRUM ANALYZER
3475 ASSIGN @Lfsa TO 711 ! HP 3585A SPECTRUM ANALYZER
3476 ASSIGN @Cntr TO 702 ! HP 5343A FREQUENCY COUNTER
3477 ASSIGN @Pwrmttr TO 713 ! HP 436A POWER METER
3478 ASSIGN @Dvm TO 722 ! HP 3455A OR 3456A DIGITAL VOLTMETER
3479 ASSIGN @Fun_gen TO 705 ! HP 3325A FUNCTION GENERATOR
3480 ASSIGN @Rf_gen TO 717 ! HP 8662A RF SYNTHESIZER
3481 ASSIGN @Het TO 720 ! HP 8340A LOCAL OSCILLATOR
3482 ASSIGN @Mod_an TO 714 ! HP 8901A OR 8902A MODULATION ANALYZER
3483 ASSIGN @Atn_drv TO 712 ! HP 11713A ATTENUATOR/RELAY DRIVER
3484 ASSIGN @Timer TO 716 ! HP 5316A COUNTER/TIMER
3485 ASSIGN @Pulse_gen TO 706
3486 ASSIGN @Pwr_supply TO 707
3487 ASSIGN @Scope TO 708 ! 54110D DIGITIZING OSCILLOSCOPE
3488 !
3489 ! @D16 ! SPARE
3490 !
3491 Prntr=701
3492 Key_bd=2
3493 Screen=1
3494 !

```

Figure 2. Program Listing, Asgn\_Test\_Equip



## PERFORMING THE MODIFICATION

After you have determined the modifications which need to be made to the HP-IB addresses, you should perform the following.

1. Bootup HP Basic 3.0 or 4.0 with the appropriate binary extensions needed to operate your system. If using an HP 9133H or 9122D, the binary extensions listed in paragraph 2.3 are all you need.
2. LOAD "FS\_MANAGER".
3. EDIT Asgn\_test equip.
4. Scroll to the line which ASSIGNS the address to the instrument you wish to modify. Make the address change and ENTER the line. An example of a possible modification would be to change the device under test's HP-IB address assignment to 30. To do this, you would scroll to the "ASSIGN @Dut TO 719" line and change 719 to 730. After making the change, you would press ENTER on your computer's keyboard.
5. Check the HP-IB assignments to ensure that the modifications you made are correct. Also check that there are no duplicate addresses!
6. If the storage media you are using for the test software is a double sided 3.5" microfloppy, you will need to PURGE "FS\_MANAGER".
7. RE-STORE "FS\_MANAGER".

# Chapter 4. Test Dependency

## 4.0 Introduction

Two types of test capability are provided in the HP 8340A/B and HP 8341A/B Attenuator Calibration and Operation Verification test software. You may either perform a calibration of the internal 90 dB step attenuator or you may perform an operation verification of the synthesizer. A listing of the individual tests provided is shown by category in Table 3.

Table 3. Listing of Tests

Operation Verification	Attenuator Calibration
Cal Constants Phase Lock Diagnostics CW Frequency Accuracy ALC Accuracy Output Power Accuracy Maximum Leveled Power	Output Power Accuracy RF Attenuator Calibrate Frequency Switching Time Cal Constants

Some of the tests require that the user generated calibration data for the HP 8485A power sensor and the HP 355D step attenuator (IF Attenuator) be resident on the disc assigned to hold this information. In addition to this requirement, some of the tests must be run in sequence to allow the test result data from a previous test to be used for a latter test. Paragraph 4.1 provides a Test Dependency Flow Chart which shows the hierarchy of the tests. Chapter 3 provides information regarding the software's mass and data storage addressing (i.e., on which disc the user generated calibration data and the test result data will be resident).

## 4.1 Test Dependency Flow Chart

The flow chart in Figure 3 shows the test interdependency. The tests and utilities included in Level 1 of the flow chart can be run independently and in any order. As shown in Level 2, the Power Sensor Cal must be run before performing the Output Power Accuracy test. Finally, as shown in Level 3, Maximum Leveled Power is dependent upon Output Power Accuracy and the Attenuator Calibration is dependent upon both Output Power Accuracy and the IF Attenuator Cal. The flow chart in Figure 3 applies to both the operation verification and calibration portions of the software.

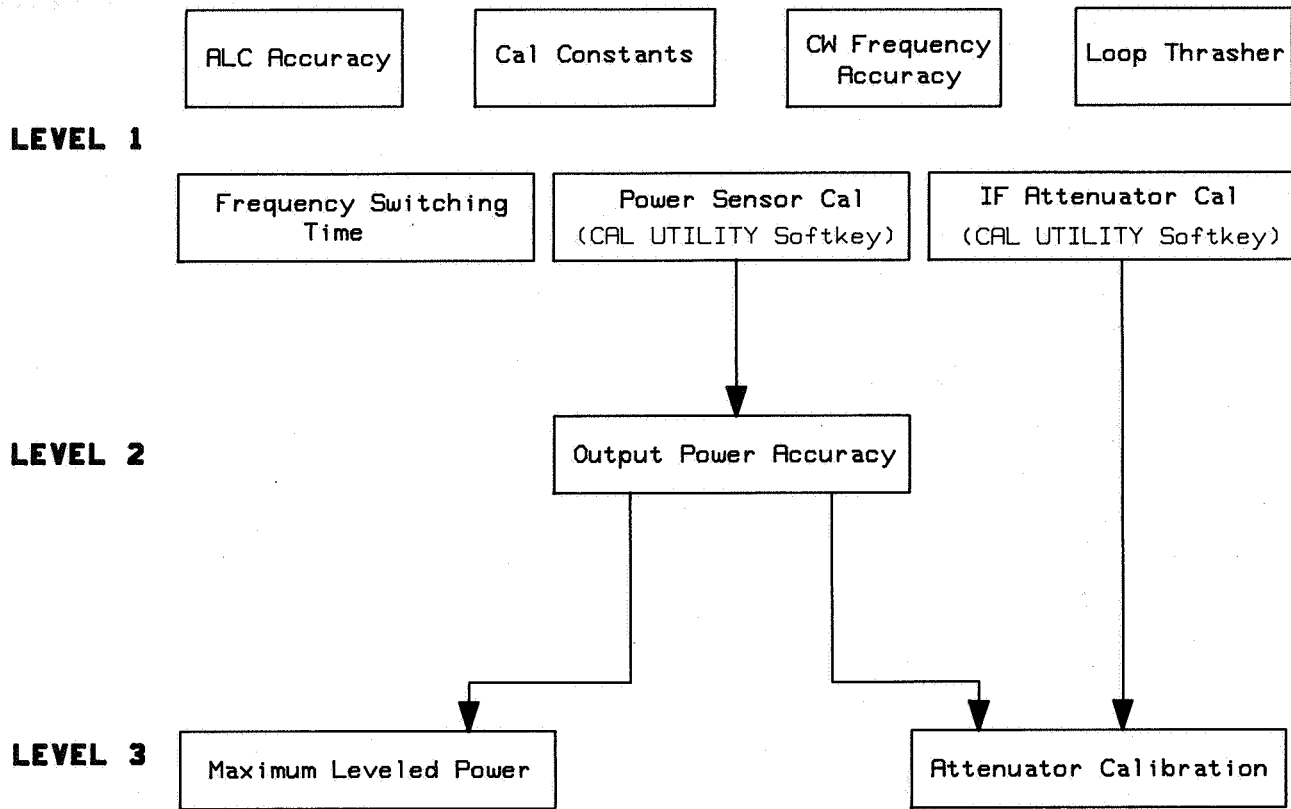

Figure 3. Test Dependency Flow Chart

## Chapter 5. Running the Software

### 5.0 Introduction

This chapter explains how to boot up the HP 8340A/B and HP 8341A/B test software and also provides a description of the 8340 FAMILY TEST SYSTEM menu.

### 5.1 System Setup

Figure 4 provides the system setup required to run the HP 8340A/B and HP 8341A/B Attenuator Calibration and Operation Verification Software. Since the computer, disc drive, and printer are common to all of the tests and utilities, they will not be repeated in the individual test setups.

The individual test setups for the tests and utilities assume that all HP-IB connections have been made to the computer, disc drive, DUT and the test equipment with HP-IB. These connections will not be shown in the individual test setups.

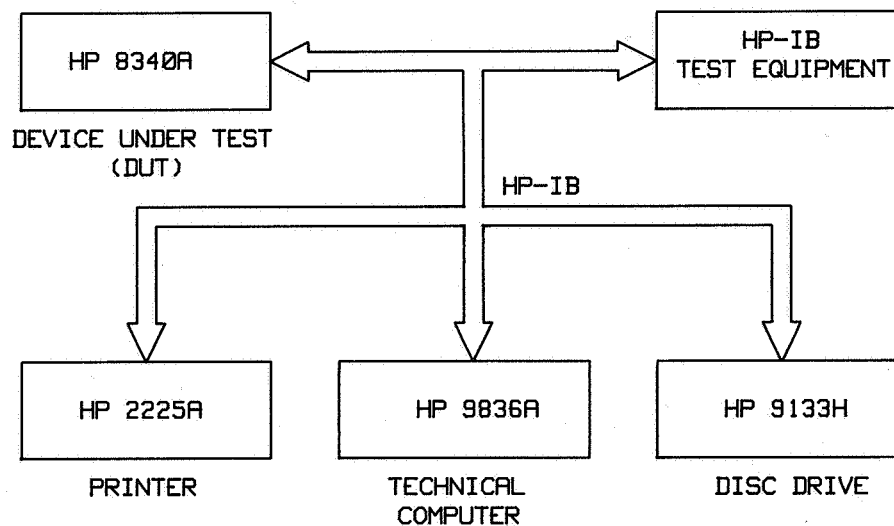

Figure 4. System Setup

## 5.2 Booting Up the Software

To boot up the test software, perform the following steps:

1. Load into your computer HP Basic 3.0 or 4.0 and the binary extensions listed in paragraph 2.3, Operating System.
2. Insert an initialized disc into the disc drive which you have designated as the data storage device (using unmodified software and an HP 9122D or 9133H this will be drive 1). After running a test, the software will automatically access the data disc and store the test data. One data disc can be used for multiple instruments. If you decide to use one data disc for multiple instruments, it is recommended that you maintain a separate data disc for your HP 8340As, HP 8340Bs, HP 8341As, and HP 8341Bs. The reason for this is that the software keys on the last four digits of the serial number when storing data and does not distinguish between the different models. If you happen to have two different models with the same ending four digits, the software may write over a data file you wish to retain.
3. Connect your Device Under Test (DUT) to the test system's HP-IB.
4. Type **LOAD "FS\_MANAGER"**, press **ENTER** and then **RUN**.
5. If the Series 200 or 300 computer has been disconnected from ac power, the program will ask you to enter the date and the time in the format shown on the screen. The date and time will be printed on the data output of each test you run. Skip this step if the computer does not ask for date and time.
6. You have now arrived at the 8340 FAMILY TEST SYSTEM menu. The choices offered are testing an HP 8340A, 8341A, 8340A Option H02, HP 8340B, HP 8341B, or running the Cal (Calibration) Utilities. To determine if you first must run the Cal Utilities, refer to Chapter 4, Test Dependency.

After you have selected the test path you wish, refer to either Chapter 6, Running the Cal Utilities, or Chapter 7, Testing an HP 8340A/B or HP 8341A/B.

## Chapter 6. Running the Cal Utilities

---

### 6.0 Introduction

The Cal Utilities portion of the software is provided to assist the operator in generating a calibration data file for the specific HP 355D step attenuator and HP 8485A power sensor being used during the tests. As mentioned in Chapter 4, Test Dependency, several of the tests require the use of the data stored in these data files before they can be run. The data files generated by the operator are stored and accessed on the storage media whose address is defined by `Calfactor_dir$` and `Cf_msus$` (discussed in Chapter 3). When using unmodified software and either an HP 9122D or 9133H, the data is located on drive 0.

Before running the Cal Utilities, you should obtain the calibration data for the attenuator and power sensor you will be using during the tests. Once the data is obtained, you can proceed with the appropriate utility. Upon completion of the utility, the data you entered will be stored. The only time you will need to re-run the Cal Utilities is when the attenuator or power sensor is re-calibrated or if you are using a device for which you have not yet entered data.

To run the Cal Utilities, press the **Cal Utility** softkey. You will then be given a choice of entering the attenuator's calibration data (**IF Attenuator** softkey) or the power sensor's calibration data (**Pwr Sensor Cal** softkey). The **Exit** softkey will return you to the 8340 FAMILY TEST SYSTEM menu. Make your selection and proceed to the appropriate entry paragraph below.

### 6.1 Entry of the IF Attenuator's (HP 355D) Calibration Data

Press the **IF Attenuator** softkey to begin entry of the attenuator's calibration data. A softkey menu which provides you the options of **Start** or **Return** will be displayed. Press the **Start** softkey to begin entry of the calibration data or the **Return** softkey to return to the CALIBRATION UTILITIES menu.

When the **Start** softkey is selected, the program will request the serial number of the attenuator and then the actual value of attenuation for the 10 dB through 70 dB steps. When entering the attenuator step values, enter the actual value (i.e., if the 10 db step is 10.02, enter 10.02). Also, the values entered should be positive. After entering all of the data, you will be given the opportunity to make corrections if necessary. Answer the rest of the questions supplied in the program and then press **Return** to return to the CALIBRATION UTILITIES menu.

### 6.2 Entry of the Power Sensor's (HP 8485A) Calibration Data

Press the **Pwr Sensor Cal** softkey to begin entry of the power sensor's calibration data. A softkey menu which provides you the options of **Start** or **Return** will be displayed. Press the **Start** softkey to begin entry of the calibration data or the **Return** softkey to return to the CALIBRATION UTILITIES menu. Before pressing the **Start** softkey, perform the 10 MHz Calibration Procedure described in paragraph 6.3.

When the **Start** softkey is selected, the program will request the serial number of the power sensor and then the Cal Factors for each sensor data point. The 10 MHz data point entry should be the value determined in paragraph 6.3. After entering all of the data, you will be given the opportunity to make corrections if necessary. When making a correction, enter the frequency in error as shown in the "Freq" column and then enter the correct value. Answer the rest of the questions supplied in the program and then press **Return** to return to the CALIBRATION UTILITIES menu.

### 6.3 10 MHz Calibration Procedure

Equipment Required:

Power Meter .....	HP 436A Option 022
Power Sensor .....	HP 8481A
Power Sensor .....	HP 8485A
Adapters:	
APC 3.5 (f) to APC 3.5 (f) <sup>1</sup> .....	HP P/N 5061-5311
APC 3.5 (f) to Type N (m) .....	HP P/N 1250-1744
APC 3.5 (f) to Type N (f) <sup>1</sup> .....	HP P/N 1250-1745

1. Connect the HP 8481A power sensor to the power meter. Allow at least one half hour for warm up. Set the power meter's calibration factor switch to include 10 MHz, then zero and calibrate the power meter before connecting the power sensor to the DUT.
2. Connect the HP 8481A power sensor to the DUT's RF output.
3. On the DUT, press **[INSTR PRESET][CW][1][0][MHz]**. Press **[RF] OFF**. Zero the power meter. Press the DUT's **[RF]** key ON. On the DUT, press **[POWER LEVEL]**. Using the rotary knob, adjust the DUT's output power to obtain a 1.0 milliwatt indication on the power meter.
4. Disconnect the HP 8481A power sensor from the DUT. Turn the power meter's line switch OFF and replace the HP 8481A with the HP 8485A power sensor. Turn the power meter's line switch back on and allow 15 minutes for the sensor to stabilize. Zero and calibrate the power meter.
5. Press the DUT's **[RF] OFF**. Connect the HP 8485A power sensor to the DUT.
6. Zero the power meter and then press the DUT's **[RF] ON**. Adjust the power meter's calibration factor dial for a power meter indication of 1.0 milliwatt. The power meter calibration factor setting is the Cal Factor % which should be entered for the HP 8485A's 10 MHz data point.

---

1. Required for an HP 8340A/B DUT only.

# Chapter 7. Testing an HP 8340A/B or HP 8341A/B

## 7.0 Introduction

Whether you are testing an HP 8340A/B or HP 8341A/B, the tests which may be run and the flow of the test software are the same. Since this is the case, this chapter will discuss the flow of the test software from the 8340 FAMILY TEST SYSTEM menu to the test menu (either the Operation Verification menu or the Attenuator Calibration menu). This chapter will not differentiate between testing an HP 8340A/B or HP 8341A/B. Once you are ready to run a specific test, you should proceed to the chapter which discusses the test you wish to run.

## 7.1 Selecting the Type of Testing

After you have selected the appropriate softkey, **Test8340A**, **Test8341A**, **TestH02** (HP 8340A Option H02), **Test8340B**, or **Test8341B**, you will be given a choice of performing an Operation Verification (**OpVer**) or Attenuator Calibration (**Cal**). For either type of testing you select, the program will proceed as follows.

1. The computer will tell you the model number and serial number it read from the instrument's Calibration Constants and ask you to verify that they are correct. If the number obtained is incorrect you will need to verify the instrument's calibration data using the hard copy of the calibration data located underneath the DUT's top cover. Otherwise, select **YES**.
2. The computer will now read the rest of the instrument's Calibration Constants. If the computer now offers the **Menu** softkey, go directly to step 3.

### CALIBRATION CONSTANT DISCREPANCIES

If there is a Cal Constants data file for this instrument on the data disc, and the file does not match the Cal Constants in the instrument, the computer will display the following:

```
DUT CAL #Cal Constant Name = ### BUT FILE = ###  
[DUT OK]           [NEITHER]           [FILE OK]
```

The most common reason for this screen to be displayed is that someone has pressed **[SHIFT] [PEAK]** on the synthesizer. This function causes the synthesizer to automatically optimize its RF output power and to update the YTM GAIN, YTM OFFSET, and the YTM BX GAIN Cal Constants. If the Cal Constant being displayed is one of those listed above, and the synthesizer does not have a front panel failure annunciator on, it is likely that the Cal Constant in the DUT is OK. In any case, it is up to the operator to determine which of the Cal Constants is valid (one method is by examining the printed copy of the Cal Constants located underneath the synthesizer's top cover) or to assume that the data disk (file) is OK.

Press the appropriate softkey in response to the prompt. If **NEITHER** is selected, you will need to enter the correct value for the Cal Constant. After all Cal Constant discrepancies are taken care of, the program will return to normal operation.



3. Enter the DUT's serial prefix number. (This is the first five alpha-numeric characters in the instrument's serial number (i.e., 2231A). If test data for this instrument exists on the current data disc (from previously run tests), the computer won't ask for the serial prefix number.
4. Enter the DUT's option configuration. Refer to the serial tag on the rear panel of the DUT and one at a time, enter the three digit option numbers shown on the serial tag (many instruments only have one option, or none at all). Once all the options have been entered, press enter. If the instrument is a standard (i.e., no options listed), just press enter. If test data for this instrument exists on the current data disc (from previously run tests), the computer will not ask for option information.
5. If the option information had to be entered in step 4, the computer will now display the options that were entered (000 will be displayed if no options were entered). If the list is correct, press **Yes**, if not, press **No** and re-enter the option configuration when prompted.
6. The software will now give you a choice of the following:

**Menu** – Allows you to access the test menu for the type of testing you selected (i.e., either Operation Verification or Attenuator Calibration).

**New DUT** – Tells the software that you have connected a different DUT to the HP-IB. Note that if the model number of the new DUT is not the same as the previous one, the program will automatically return you to the 8340 FAMILY TEST SYSTEM menu.

7. If **Menu** is selected, the test menu name and the tests which may be run will be displayed. At this point, select the appropriate softkey. You have the following choices:

**Input #** – Allows you to enter the specific test number you wish to run.

**Auto Sequence** – The auto sequence menu allows you to select which tests to run automatically. When the tests are selected (**ON** or **All on** softkey and then the **Execute** softkey are pressed), the program will automatically load the first test. At the end of each test, the next test will then be loaded. This feature saves having to return to the test menu after each test.

**LoopTest** – Allows you to run the selected test (test the cursor is pointing to) however many times you wish. The cursor position can be changed by using the rotary control knob on the keyboard or the up/down keys.

**PrevPage** – Not implemented on this version of software.

**Utility** – Allows you to access the Test Menu Utilities (see Chapter 16 for detailed information on how to use the utilities described below). The Utilities which you may choose from are as follows:

- \* Change the option configuration Cal Constants in the DUT (used when retrofitting options).
- \* Display or print the data from any of the tests you have run.
- \* Display or print the test status for any instrument you have tested.

- SELECT** - Selects the test to which the cursor is pointing. The cursor position can be changed by using the rotary control knob on the keyboard or the up/down keys.
- NextTest** - Automatically selects the next test to be run.
- NextPage** - Not implemented on this version of software.
- Exit** - Exits you from this menu.

8. Select the desired test or utility and refer to the appropriate chapter. See Table 4.

*Table 4. Chapters Containing Test/Utility Descriptions*

<b>Test/Utility</b>	<b>Chapter</b>
Calibration Constants	8
Phase Lock Diagnostics	9
CW Frequency Accuracy	10
ALC Accuracy	11
Output Power Accuracy	12
Maximum Leveled Power	13
RF Attenuator Calibration	14
Frequency Switching Time	15
Test Utilities	16

# Chapter 8. Calibration Constants Utility

---

## 8.0 Description

This program is not a test in that it does not verify conformance to a specification. Rather it is a utility program which allows the operator to manipulate the Calibration Constants in the instrument or in the data disc file. Calibration Constants either from the instrument or data disc may be viewed or printed; Cal Constants may be transferred from the instrument onto the data disc (image file), or vice versa; or the Cal Constants in an image file may be compared with those in the instrument.

## 8.1 Test Equipment

None required.

## 8.2 Procedure

1. The softkeys provided for this utility are as follows:

<b>COMPARE</b>	- Compares current instrument Cal Constants with the image file. This is the key you should select to meet the requirements for the operation verification.
<b>ReadDUT</b>	- Reads the DUT's Cal Constants into the computer's memory.
<b>GetFILE</b>	- Loads the Cal Constant image file for the DUT into the computer's memory.
<b>EXIT</b>	- Return to the test menu.

Select the desired softkey.

2. After any of the above three selections are made, the program will offer the following additional softkeys:

<b>PRINT</b>	- Prints the Cal Constants currently in the computer's memory.
<b>DISPLAY</b>	- Displays the Cal Constants currently in memory.
<b>Wrt DUT</b>	- Writes the Cal Constants in the computer's memory to the instrument's WORKING Cal Constant memory and then stores the Cal Constants into the instrument's PROTECTED Cal Constant memory.
<b>SavFILE</b>	- Takes the Cal Constants in the computer's memory and creates a permanent image file on the data disc.

Select the desired softkey and respond to any prompts provided by the program.

# Chapter 9. Phase Lock Diagnostics

---

## 9.0 Description

This program is not a test in that it does not verify conformance to a specification. Rather it is a diagnostic which tests the integrity of the internal phase lock loops. The diagnostic causes the phase lock loop frequency to be switched very rapidly from one extreme to the next. During this process, the synthesizer is polled for an unlock indication to determine if phase lock has been lost. If at any point during the test an unlock indication is detected, the diagnostic will indicate which phase lock loop was unlocked.

## 9.1 Test Equipment

None required.

## 9.2 Procedure

1. The softkeys provided for this diagnostic are as follows:

**THRASH**            - Runs the diagnostic. This is the key you should select to meet the requirements for the operation verification.

**JANITOR**         - Returns you to the test menu.

Select the desired softkey.

# Chapter 10. CW Frequency Accuracy Test

---

## 10.0 Description

The synthesizer's RF output is connected to a frequency counter. The frequency counter's internal time base is used as the reference for the synthesizer to eliminate time base error from the measurement. The synthesizer's display and the counter's display should agree, within the resolution of each instrument. This procedure does not test for CW frequency accuracy as a function of the time base accuracy.

In the following test, the test frequencies are selected to exercise each frequency related circuit throughout the synthesizer while holding all remaining circuits constant. The test frequencies are grouped so that an abnormal indication would point to the circuit most likely causing the problem. Once this test is completed, the endpoint accuracy of the synthesizer is tested.

## 10.1 Test Equipment

Frequency Counter .....	HP 5343A Option 011
Cables:	
Semi-rigid coax, SMA (m) to SMA (m) .....	HP P/N 08340-20124
BNC (m) to BNC (m), (2 required) .....	HP P/N 8120-1840
Adapters:	
APC 3.5 (f) to APC 3.5 (f), (2 Required) .....	HP P/N 5061-5311
SMA (m) to BNC (f) .....	HP P/N 1250-1200
Type N (m) to SMA (f) <sup>1</sup> .....	HP P/N 1250-1250

---

1. Required for an HP 8341A/B DUT only.

## 10.2 Procedure

1. The softkeys provided for this test are as follows:

- |                    |  |
|--------------------|--|
| <b>Setup</b>       | - Provides a graphical display of the CW Frequency Accuracy Test setup on the CRT.                                 |
| <b>M/N</b>         | - Test the M/N phase lock loop only.   |
| <b>20/30</b>       | - Test the 20/30 phase lock loops only.  |
| <b>ENDPNT ACCY</b> | - Test the synthesizer's frequency endpoints and the YIG oscillator's frequency endpoints.                         |
| <b>ALL</b>         | - Test all of the above. This is the key you should select to meet the requirements of the operation verification. |
| <b>Print</b>       | - Must be pressed before each test is run to obtain a printout of the test data. No data is stored for this test.  |
| <b>DONE</b>        | - Return to the test menu.   |

Select the desired softkey and respond to any prompts provided by the program. In order to get the test menu STATUS to indicate PASS, all three of the above test must be run and pass.

2. If a test should fail, the program will pause and give you a softkey choice of:

- |               |   |
|---------------|---|
| <b>CONT.</b>  | - Proceed with the next step of the test. |
| <b>REPEAT</b> | - Repeat the test that was run.           |
| <b>ABORT</b>  | - Return to the softkey menu in step 1.   |

Select the desired softkey and respond to any prompts provided by the program.

# Chapter 11. ALC Accuracy Verification

---

## 11.0 Description

This program is not a test in that it does not verify conformance to a specification. Rather it is a verification of the operation of the automatic leveling control (ALC) circuitry. This verification is used to alert the operator to any problems which may exist in the ALC. A problem in this circuitry will directly impact the output power flatness and accuracy, which is specified.

Since the ALC is not frequency dependent, the test is performed at two frequency points; one point in Band 0 and the other in Band 1. Checking the ALC in these two bands verifies its operation in the synthesizer's low frequency RF path and high frequency RF path. At each frequency, the ALC is tested over its entire power range, -20 dBm up to maximum available leveled power.

## 11.1 Test Equipment

Power Meter .....	HP 436A Option 022
Power Sensor .....	HP 8485A
Adapters:	
APC 3.5 (f) to APC 3.5 (f) <sup>1</sup> .....	HP P/N 5061-5311
APC 3.5 (f) to Type N (m) <sup>2</sup> .....	HP P/N 1250-1744
Cable, Semi-rigid coax, SMA (m) to SMA (m) .....	HP P/N 08340-20124

## 11.2 Procedure

1. The softkeys provided for this test are as follows:

<b>VERIFY</b>	- Runs the ALC verification. This is key you should select to meet the requirements of an operation verification.
<b>SETUP</b>	- Provides a graphical display of the ALC accuracy test setup on the CRT.
<b>JANITOR</b>	- Return to the test menu.

Select the desired softkey and respond to any prompts provided by the program.

2. Upon completion of the verification, the test will indicate pass or fail and will display the following softkeys:

<b>PRINT</b>	- Output the test results to the printer.
<b>DISPLAY</b>	- Output the test results to the CRT.
<b>DONE</b>	- Return to the menu in step 1.

Select the desired softkey and respond to any prompts provided by the program.

---

1. Required for an HP 8340A/B DUT only.  
2. Required for an HP 8341A/B DUT only.

# Chapter 12. Output Power Accuracy Test

---

## 12.0 Description

The Output Power Accuracy Test checks the flatness and accuracy of the synthesizer's RF output. The test is performed across the synthesizer's entire frequency range with three different power level settings. For this test, a power sensor and power meter are connected to the synthesizer's RF output. The data obtained from this test is required by the Maximum Leveled Output Power test and the Attenuator Calibration test.

### NOTE

**This test will not run unless the power sensor has been characterized per the instructions in Chapter 6. The data file generated for the power sensor must be on the data disc currently in the disc drive.**

## 12.1 Test Equipment

Power Meter .....	HP 436A Option 022
Power Sensor .....	HP 8485A
Adapters:	
APC 3.5 (f) to APC 3.5 (f) <sup>1</sup> .....	HP P/N 5061-5311
APC 3.5 (f) to Type N (m) .....	HP P/N 1250-1744

## 12.2 Procedure

1. The softkeys provided for this test are as follows:

<b>SET UP</b>	- Provides a graphical display of the Output Power Accuracy test setup on the CRT.
<b>VERIFY</b>	- Runs the test which verifies the output power accuracy performance of the synthesizer. This is the key you should select to meet the requirements for the operation verification.
<b>SELECT</b>	- Allows you to check the output power accuracy for a specific frequency range. Also allows you to select the number of points and power level you wish to test. When the program requests the test parameters, only enter the number. For example, when the program requests the start frequency, enter 4 (not 4 GHz). No data is stored when this softkey is selected.
<b>JANITOR</b>	- Returns you to the test menu.

Select the desired softkey and respond to the prompts provided by the program.

---

<sup>1</sup>. Required for an HP 8340A/B DUT only.



2. When the test you selected is finished, the program will indicate whether the instrument passed or failed the test. In either case, a menu will be displayed with the following selections:

<b>DISPLAY</b>	- Outputs the test results to the CRT.
<b>PRINT</b>	- Output the test results to the Printer.
<b>BEGIN</b>	- Returns you to the Output Power Accuracy Test menu.
<b>JANITOR</b>	- Returns you to the test menu.

If the test fails, the program will suggest that the instrument be adjusted and tested again. Select the desired softkey and respond to the prompts provided by the program.

# Chapter 13. Maximum Leveled Output Power Test

## 13.0 Description

The Maximum Leveled Output Power test verifies that the synthesizer meets its maximum leveled power specifications over a variety of sweep ranges, sweep modes, and sweep speeds. The test uses the internal power meter and unleveled indication circuitry within the synthesizer to measure maximum leveled power. Upon completion of the test, the program uses the measurement data obtained from this test and the test data obtained from the Output Power Accuracy test to calculate the actual maximum leveled output power. The results from the calculations are compared with the maximum leveled output power specifications to determine if the DUT passed or failed.

Since the test uses circuitry internal to the synthesizer to perform the measurements, no equipment is required except for a 20 dB attenuator. The 20 dB attenuator is used to provide a 50 Ohm load on the output of the DUT (improves the measurement accuracy).

### NOTE

**This test will not run unless the Output Power Accuracy test has been performed. The data file generated for the verification must be on the data disc currently in the disc drive.**

## 13.1 Test Equipment

20 dB Attenuator .....	HP 8493C Option 020
Adapters:	
APC 3.5 (f) to APC 3.5 (f) <sup>1</sup> .....	HP P/N 5061-5311
APC 3.5 (f) to Type N (m) <sup>2</sup> .....	HP P/N 1250-1744

## 13.2 Procedure

1. The softkeys provided for this test are as follows:

- |               |  |
|---------------|--|
| <b>FULL</b>   | - Runs the entire Maximum Leveled Output Power test. This is the key you should select to meet the requirements for the operation verification.                                |
| <b>SELECT</b> | - Allows you to select the sweep mode and sweep range you wish to test. When the program prompts you for the test condition, type the appropriate test number and press enter. |

1. Required for an HP 8340A/B DUT only.  
2. Required for an HP 8341A/B DUT only.

**CORRECT** – Allows you to view the power accuracy correction factors, obtained from the Output Power Accuracy test, which will be used during the calculation of the maximum leveled output power. Examine the data and then press continue on the computer's keyboard.

**JANITOR** – Returns you to the test menu.

Select the desired softkey and respond to the prompts provided by the program.

2. When the test you selected is finished, the program will indicate whether the instrument passed or failed the test. In either case, a menu will be displayed with the following selections:

**RETEST** – Returns you to the MAXIMUM LEVELED OUTPUT POWER menu.

**JANITOR** – Returns you to the test menu.

**DISPLAY** – Outputs the test results to the CRT.

**PRINT** – Output the test results to the Printer.

Select the desired softkey and respond to the prompts provided by the program.

# Chapter 14. RF Attenuator Calibration

---

## 14.0 Description

This program performs three functions:

- It adjusts the instrument's attenuator calibration constants to compensate for errors in the 90 dB step attenuator (for those instruments so equipped).
- It verifies power accuracy at each attenuator step.
- It sums the attenuator performance data with output power accuracy data and compares the results with the instrument's performance specifications.

### NOTE

**This test will not run unless the IF attenuator has been characterized per instructions in Chapter 6 and the Output Power Accuracy test has been run. The data files generated by the IF attenuator and Output Power Accuracy programs must be on the data disc currently in the disc drive.**

## 14.1 Test Equipment

Local Oscillator .....	HP 8340A Option HO1 or HP 8340A/B Option 001
Spectrum Analyzer .....	HP 3585A
Mixer .....	HP P/N 0955-0307
20 dB Attenuator .....	HP 8493C Option 020
10 dB Attenuator .....	HP 8493C Option 010
Step Attenuator (Calibrated at 1 MHz) .....	HP 355D
Low Pass Filter .....	HP P/N 9135-0260
Amplifier .....	HP 8447F
Cables:	
Semi-rigid coax, SMA (m) to SMA (m) .....	HP P/N 08340-20124
BNC (m) to BNC (m), (7 required) .....	HP P/N 8120-1840
Adapters:	
APC 3.5 (f) — APC 3.5 (f) <sup>1</sup> .....	HP P/N 5061-5311
APC 3.5 (f) to Type N (m) <sup>2</sup> .....	HP P/N 1250-1744
SMA (m) to BNC (f) .....	HP P/N 1250-1200

---

1. Required for an HP 8340A/B DUT only.  
2. Required for an HP 8341A/B DUT only.

## 14.2 Procedure

### NOTE

Instrument Calibration Constants tell the program whether or not an attenuator is installed. If an attenuator was installed after time of manufacture, Calibration Constant #59 should have been changed to reflect the addition. If this Cal Constant was not updated, the program will tell you that no attenuator exists, even though one is actually installed. To update the Cal Constants to reflect the correct option configuration (i.e., 90 dB attenuator option installed), return to the test menu and select the Utility softkey. Refer to Chapter 16, and then select the Chg Option softkey.

### PROBLEM SOLVER

If you run into difficulties during this test (due to an incorrect test setup, etc), and the softkey menu gives you no ABORT selection, press [Carry On] or other "continue" commands until you get to a menu that lets you abort the test. It is not recommended to do a full program break. If you break the program, some Cal Constants may already have been altered in the instrument. A controlled abort allows the program to replace the instrument's original Cal Constants before exiting the test. A hard STOP does not do this, and when you go to run the program again the program will indicate:

DUT CAL #AT10 OFFSET = ### BUT FILE = ###

[DUT OK]            [NEITHER]            [FILE OK]

This screen is telling you that a Cal Constant difference exists between the data disc image file and the instrument. It will then let you choose which is the correct Cal Constant. In this case, the image file is correct. For each Cal Constant discrepancy (sequentially) displayed, press [FILE OK]. After several Cal Constant discrepancies are displayed, the program will return to normal operation.

1. The softkeys provided for this test are as follows:

- |                |  |
|----------------|--|
| <b>ADJUST</b>  | - Does everything. It adjusts the Calibration Constants; verifies power accuracy at every attenuator step; it also sums the attenuator performance data with the output power accuracy data and compares the results to instrument specifications. After this key is selected, press the <b>ALL</b> softkey to adjust and measure all of the attenuator steps. If only one step is selected, no data will be stored.           |
| <b>MEASURE</b> | - This is a subset of the ADJUST test. MEASURE verifies the low output power accuracy at every attenuator step; it also sums the attenuator performance data with the output power accuracy data and compares the results to instrument specifications. After this key is selected, press the <b>ALL</b> softkey to measure all the attenuator steps and store the data. If only one step is selected, no data will be stored. |
| <b>SPEC</b>    | - This is a subset of the above tests. SPEC simply takes existing attenuator performance data and sums it with output power accuracy data. The result is compared to instrument specifications   |
| <b>Viewdat</b> | - Allows you to view the test result data on the computer's CRT. After this key is pressed, you are given a choice of viewing the individual attenuator step data or viewing all the data.   |
| <b>Hardcpy</b> | - Same as the <b>Viewdata</b> softkey except the selected data is output to the printer.   |
| <b>JANITOR</b> | - Returns you to the test menu.  |

Select the desired softkey and respond to the prompts provided by the program.

#### NOTE

The test setup for the Adjust and Measure portions of the RF Attenuator Calibration is extremely critical. The tests and adjustments are performed at low RF output power levels (down to  $-90$  dBm). Use of a defective cable or adapter, or having a loose cable connection in the test setup may cause a misadjustment of the instrument or failure in the low output power accuracy test. If the test results indicate that the instrument failed low output power accuracy, check the test setup and re-run the selected test (either Adjust or Measure).

#### NOTE

The program will repeat the "Set IF attenuator" statement for each measurement, even though the proper attenuation has already been set.

# Chapter 15. Frequency Switching Time Test

---

## 15.0 Description

The Frequency Switching Time test verifies that the synthesizer meets its frequency switching time specification. The test uses the synthesizer's negative blanking output on its rear panel and an HP 5316A to measure the time it takes the instrument to switch from one CW frequency to another. The frequencies selected for testing are those which will cause the worst case delay in the switching time.

## 15.1 Test Equipment

Universal Counter .....	HP 5316A
Cable:	
BNC (m) to BNC (m) .....	HP P/N 8120-1840

## 15.2 Procedure

1. Connect the equipment and set the HP 5316A as shown on the CRT. Press **Cont.**
2. The softkeys provided for this test are as follows:

- |                |   |
|----------------|---|
| <b>FullTst</b> | - Performs the entire Frequency Switching Time test and compares the test results to the synthesizer's specifications. Upon completion of this test, the test results will be displayed. Press the <b>Carry On</b> softkey and then select either <b>RE-TEST</b> , returns you to the FREQUENCY SWITCHING TIME menu, or <b>JANITOR</b> , returns you to the test menu.  |
| <b>Other</b>   | - Allows you to select the two CW frequencies between which the test will switch. After selecting <b>Other</b> , you are given a choice of entering the two frequency points ( <b>A to B</b> ), entering one frequency point and the frequency step size ( <b>A to A + d</b> ), running the full test ( <b>FullTest</b> ), or returning to the test menu ( <b>Janitor</b> ). If you select <b>A to B</b> or <b>A to A + d</b> , the frequency you enter must be in MHz. |
| <b>Janitor</b> | - Returns you to the test menu.   |

Select the desired softkey and respond to the prompts provided by the program.

## Chapter 16. Test Menu Utility Softkey

---

### 16.0 Description

The test menu **Utility** softkey provides you with the capability of changing the synthesizer's defined option configuration (option configuration defined by the Cal Constants) from your computer, displaying data from previously run tests, or displaying the test status of previously tested instruments. The feature which allows you to change the synthesizer's defined option configuration should be used after an option has been added to or deleted from the synthesizer.

### 16.1 Test Equipment

None Required.

### 16.2 Procedure

1. After the **Utility** softkey provided in the test menu has been selected, the program will display the following softkey choices:

- |                   |   |
|-------------------|---|
| <b>Chg Option</b> | - Allows you to change the synthesizer's defined option configuration. After selecting this softkey, input each of the synthesizer's 3 digit option strings (one at a time) and press ENTER after each entry. Press ENTER when finished inputting the options and then check the option list. Upon completion of the option entry, the program will automatically update the calibration constants in the synthesizer and the data file on the data disc to reflect the option configuration you entered.   |
| <b>Dsp Data</b>   | - Allows you to display or print the test data from previously run tests. The data displayed will be for the instrument whose serial number is currently in the computer's memory and for the type of testing you selected while in the TEST SELECTION menu (i.e., either the Operation Verification or the Attenuator Calibration). After selecting this softkey, the program will display the test menu and allow you to output all the test data ( <b>ALL DATA</b> softkey), output the data for one test ( <b>SELECT</b> softkey), or return to the UTILITIES menu ( <b>EXIT</b> softkey). The <b>SELECT</b> softkey outputs the data for the test at which the cursor points. Use the keyboards UP or DOWN arrow keys or the rotary control knob on the keyboard to position the cursor. |
| <b>Prt Status</b> | - Allows you to display or print the test status for the synthesizer whose serial number is currently in the computer's memory. The status displayed will be for the type of testing you selected while in the TEST SELECTION menu (i.e., either the Operation Verification or the Attenuator Calibration menu).  |
| <b>Exit</b>       | - Returns you to the test menu.   |

Select the desired softkey and respond to the prompts provided by the program.



2. If you have finished viewing the test data (or the test status) obtained from the Operation Verification and wish to view the data from the Attenuator Calibration (or vice versa), you must return to the TEST SELECTION menu. Press the exit softkeys until you reach this menu and then press the appropriate softkey.

#### NOTE

To view a DUT's test data or test status, it is not necessary to have the DUT connected to the HP-IB. The only requirements are that the DUT's data disc be installed in the data disc drive, you know the DUT's serial number, and a DUT with a different serial number is not attached to the HP-IB. To implement this feature, access the TEST SELECTION menu and select the type of testing for which you wish to view the data. If a DUT is not attached to the HP-IB, the program will ask you if you wish to continue without one. Press the YES softkey and enter the DUT's serial number. Proceed to the test menu and select the Utility softkey. From here, you can either display the test data or test status as described above.

## REGIONAL SALES AND SUPPORT OFFICES

*For information relating to Sales or Support of Hewlett-Packard products first contact your local Hewlett-Packard office listed in the white pages of your telephone directory. If none is listed locally, contact one of the addresses listed below to obtain the address or phone number of the Hewlett-Packard Sales or Support office nearest you.*

### ASIA

Hewlett-Packard Asia Ltd.  
47/F, 26 Harbour Road,  
Wanchai, **HONG KONG**  
G.P.O. Box 863, Hong Kong  
Tel: (852) 5-8330833  
Telex: 76793 HPA HX  
Cable: HPASIAL TD

### AUSTRALASIA

Hewlett-Packard Australia Ltd.  
31-41 Joseph Street  
**BLACKBURN**, Victoria 3130  
Australia  
Tel: (61) 895-2895  
Telex: 31-024  
Cable: HEWPARD Melbourne

### CANADA

Hewlett-Packard (Canada) Ltd.  
6877 Goreway Drive  
**MISSISSAUGA**, Ontario L4V 1M8  
Tel: (416) 678-9430  
Telex: 069-8644

### JAPAN

Yokogawa-Hewlett-Packard Ltd.  
29-21 Takaido-Higashi, 3 Chome  
Suginami-ku **TOKYO** 168  
Tel: 03 (331) 6111  
Telex: 232-2024 YHPTOK

### MEDITERRANEAN AND MIDDLE EAST

Hewlett-Packard S.A.  
Mediterranean and Middle East  
Operations  
Atrina Centre  
32 Kifissias Avenue  
Paradissos-Amarousion, **ATHENS**  
Greece  
Tel: (30) 682 88 11  
Telex: 21-6588 HPAT GR  
Cable: HEWPACKSA Athens

### BENELUX & SCANDINAVIA

Hewlett-Packard S.A.  
Uilenstede 475  
P.O. Box 999  
NL-1183 AG **AMSTELVEEN**  
The Netherlands  
Tel: (31) 20/43 77 71  
Telex: 18 919 hpner nl

### SOUTH & EAST EUROPE, AFRICA

Hewlett-Packard S.A.  
7, rue du Bois-du-Lan  
CH-1217 **MEYRIN 2**, Geneva  
Switzerland  
Tel: (41) 22/83 12 12  
Telex: 27835 hmea  
Cable: HEWPACKSA Geneve

### FRANCE

Hewlett-Packard France  
Parc d'activités du Bois Briard  
2, avenue du Lac  
91040 **EVRY** Cedex  
Tel: 1 6/077 83 83  
Telex: 6923 15F

### GERMAN FEDERAL REPUBLIC

Hewlett-Packard GmbH  
Hewlett-Packard-Strasse  
Postfach 1641  
D-6380 **BAD HOMBURG**  
West Germany  
Tel: 06172/400-0  
Telex: 410 844 hpbhg

### ITALY

Hewlett-Packard Italiana S.p.A.  
Via G. Di Vittorio 9  
1-20063 **CERNUSCO SUL  
NAVIGLIO**  
(Milano)  
Tel: 02/92 36 91  
Telex: 334632

### UNITED KINGDOM

Hewlett-Packard Ltd.  
King Street Lane  
Winnersh, **WOKINGHAM**  
Berkshire RG11 5AR  
Tel: 734/78 47 74  
Telex: 847178

### EASTERN USA

Hewlett-Packard Co.  
4 Choke Cherry Road  
**ROCKVILLE**, MD 20850  
Tel: (301) 670-4300

### MIDWESTERN USA

Hewlett-Packard Co.  
5201 Tollview Drive  
**ROLLING MEADOWS**, IL 60008  
Tel: (312) 255-9800

### SOUTHERN USA

Hewlett-Packard Co.  
2000 South Park Place  
P.O. Box 105005  
**ATLANTA**, GA 30348  
Tel: (404) 955-1500

### WESTERN USA

Hewlett-Packard Co.  
5161 Lankershim Blvd.  
P.O. Box 3919  
**NO. HOLLYWOOD**, CA 91609  
Tel: (818) 506-3700

### OTHER INTERNATIONAL AREAS

Hewlett-Packard Co.  
Intercontinental Headquarters  
3495 Deer Creek Road  
**PALO ALTO**, CA 94304  
Tel: (415) 857-1501  
Telex: 034-8300  
Cable: HEWPACK

February, 1986



**HEWLETT  
PACKARD**