

Errata

Title & Document Type: 8118A Pulse/Pattern Generator Quick Reference Guide

Manual Part Number: 08118-90021

Revision Date:1988-01-01

HP References in this Manual

This manual may contain references to HP or Hewlett-Packard. Please note that Hewlett-Packard's former test and measurement, semiconductor products and chemical analysis businesses are now part of Agilent Technologies. We have made no changes to this manual copy. The HP XXXX referred to in this document is now the Agilent XXXX. For example, model number HP8648A is now model number Agilent 8648A.

About this Manual

We've added this manual to the Agilent website in an effort to help you support your product. This manual provides the best information we could find. It may be incomplete or contain dated information, and the scan quality may not be ideal. If we find a better copy in the future, we will add it to the Agilent website.

Support for Your Product

Agilent no longer sells or supports this product. You will find any other available product information on the Agilent Test & Measurement website:

www.tm.agilent.com

Search for the model number of this product, and the resulting product page will guide you to any available information. Our service centers may be able to perform calibration if no repair parts are needed, but no other support from Agilent is available.

HP 8118A

PULSE/PATTERN GENERATOR

GETTING STARTED & QUICK REFERENCE GUIDE

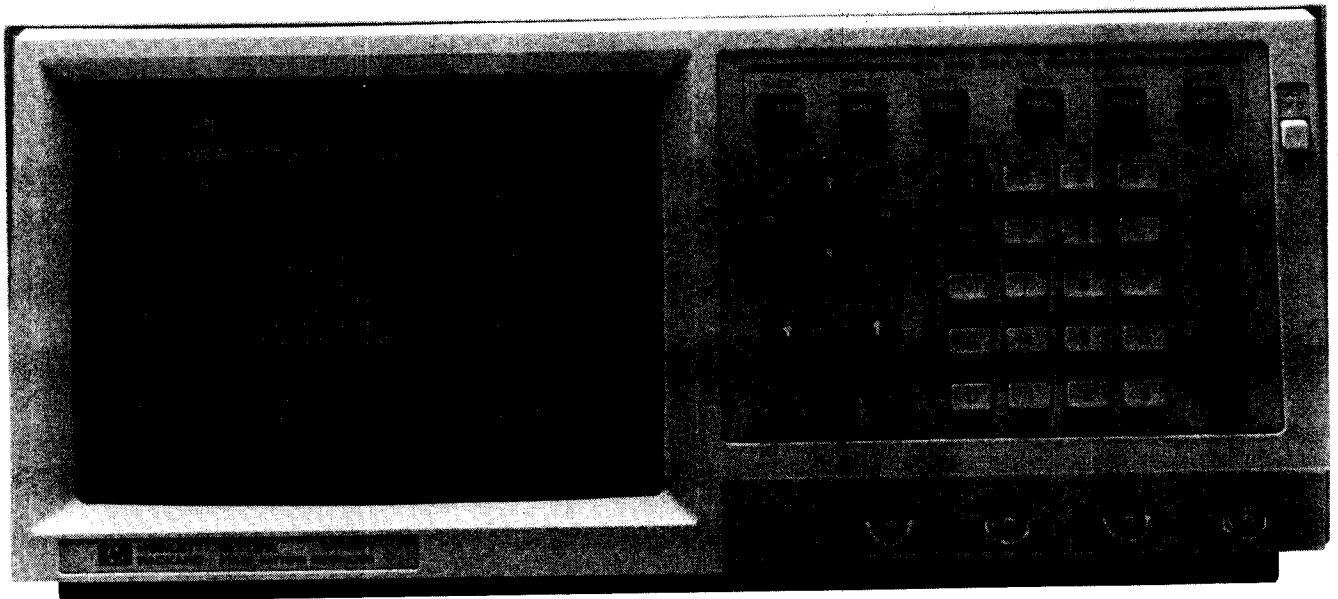

 **HEWLETT
PACKARD**

TABLE OF CONTENTS

CHAPTER I INTRODUCTION

GETTING STARTED	I-1
SELECT THE ...	I-2
MAIN DISPLAYS	I-3/4

CHAPTER II STAND ALONE OPERATION - STEP BY STEP

1	CONFIGURATION SETUP	II-1
2a	DATA FORMAT INPUT	II-2
2b	DATA ENTRY	II-3
3	TIMING INPUT	II-4
	CONTROL	II-4
4	OUTPUT SETTING	II-5
	HELP	II-5
5a	PERIPHERAL SETUP	II-6
5b	SAVE INTERNALLY	II-7
5c	SAVE EXTERNALLY	II-8

CHAPTER III REMOTE CONTROLLED - DEVICE COMMANDS

COMMAND HIERARCHY	III-1
:INPut	III-2/3
:PULSe	III-4/5/6
:OUTPut	III-6
:DATA	III-7
:SYSTem	III-8

GETTING STARTED

and Quick Reference Guide

Let us do the following example in section Step by Step.

You will set up a data stream , and you ask yourself which pages you have to call for inputting the data and parameters of your data stream.

Data stream example :

data length	: 64 bit
word length	: 8 bit
cycling mode	: auto (continuous)
breakpoint	: at bit 51 (word 6, bit3)
data format	: RZ
data (hexadecimal)	: A8, 09, 3D, F1, 54, 2B, 6E, 10
period	: 100 ns
delay (vs. strobe)	: 50 ns
width	: 30 ns
high level	: +5 V
low level	: -2 V
strobe trigger	: word
strobe width	: 60 ns

..additionally, we want to store the programmed data stream internally and externally.

SELECT THE ...

MAIN DISPLAYS

with the

MAIN DISPLAY KEYS

EDIT FUNCTIONS

with the

2nd level (Shift) of the

FUNCTIONS & MODES

with the

MAIN DISPLAY KEYS

[NEXT / PREV] KEYS

VALUES & PATTERN

with the

KEYPAD

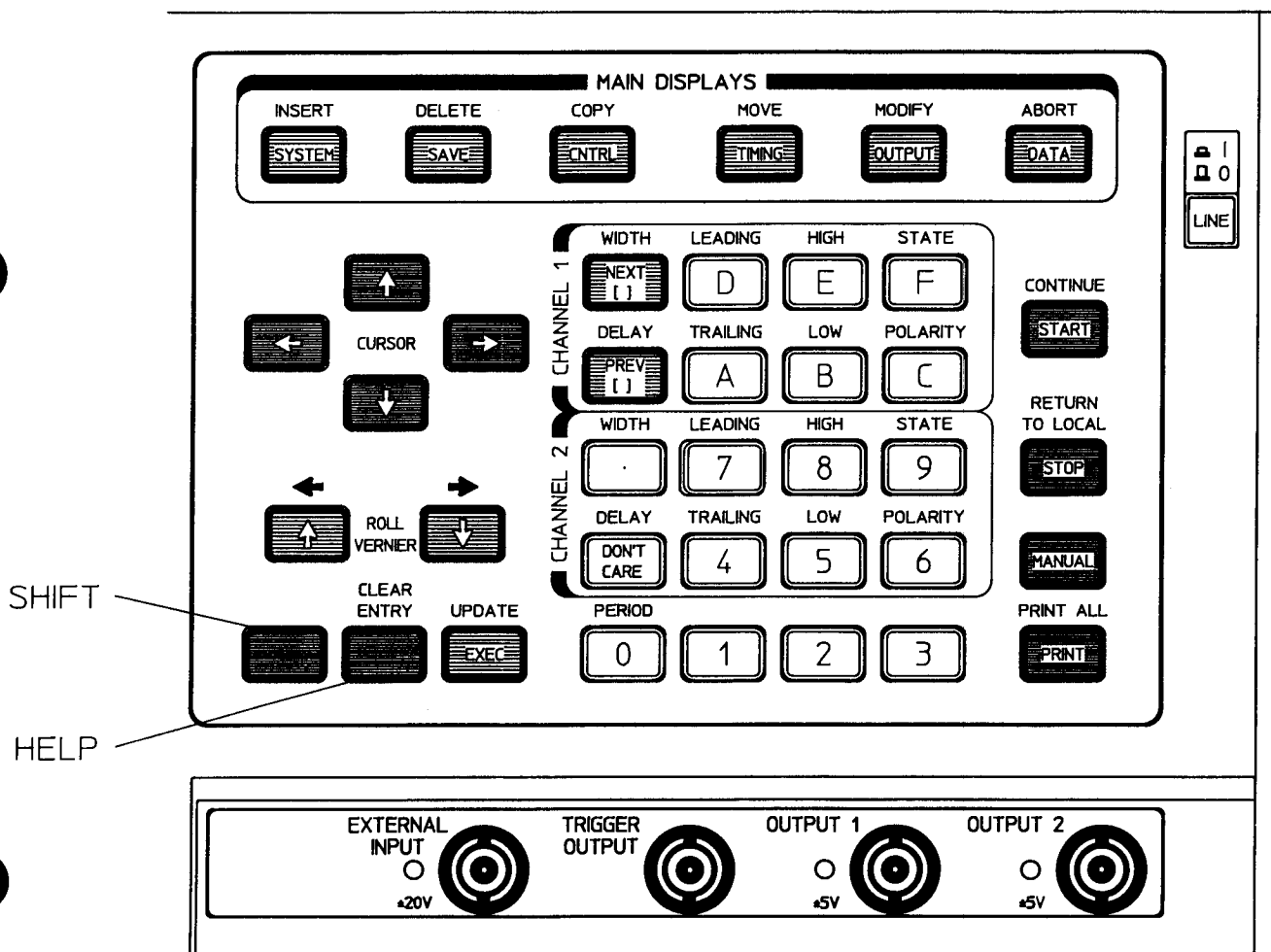

MAIN DISPLAYS

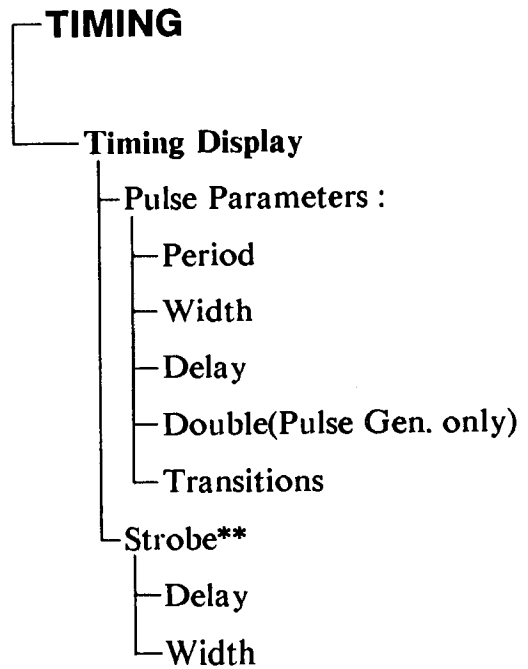
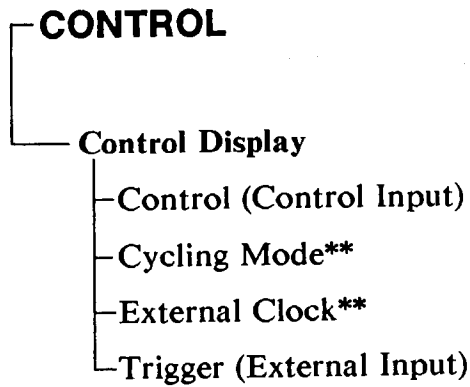
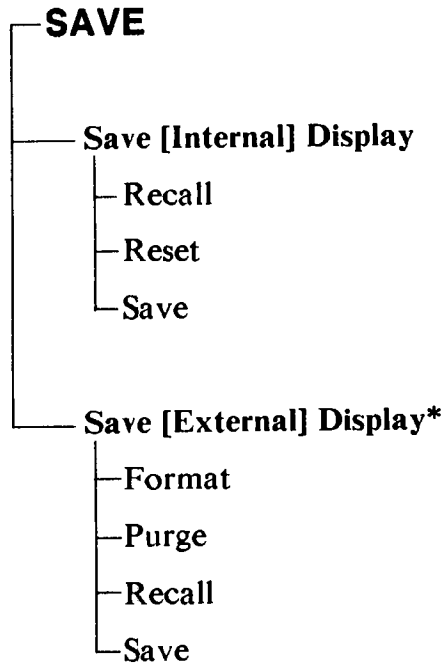
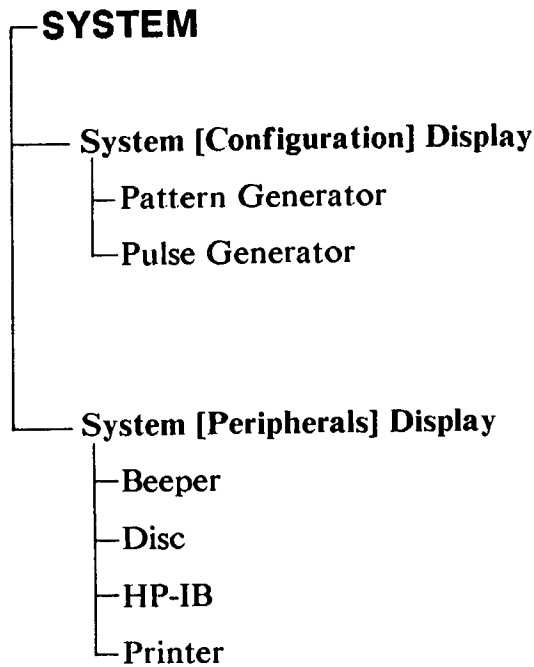

MAIN DISPLAYS

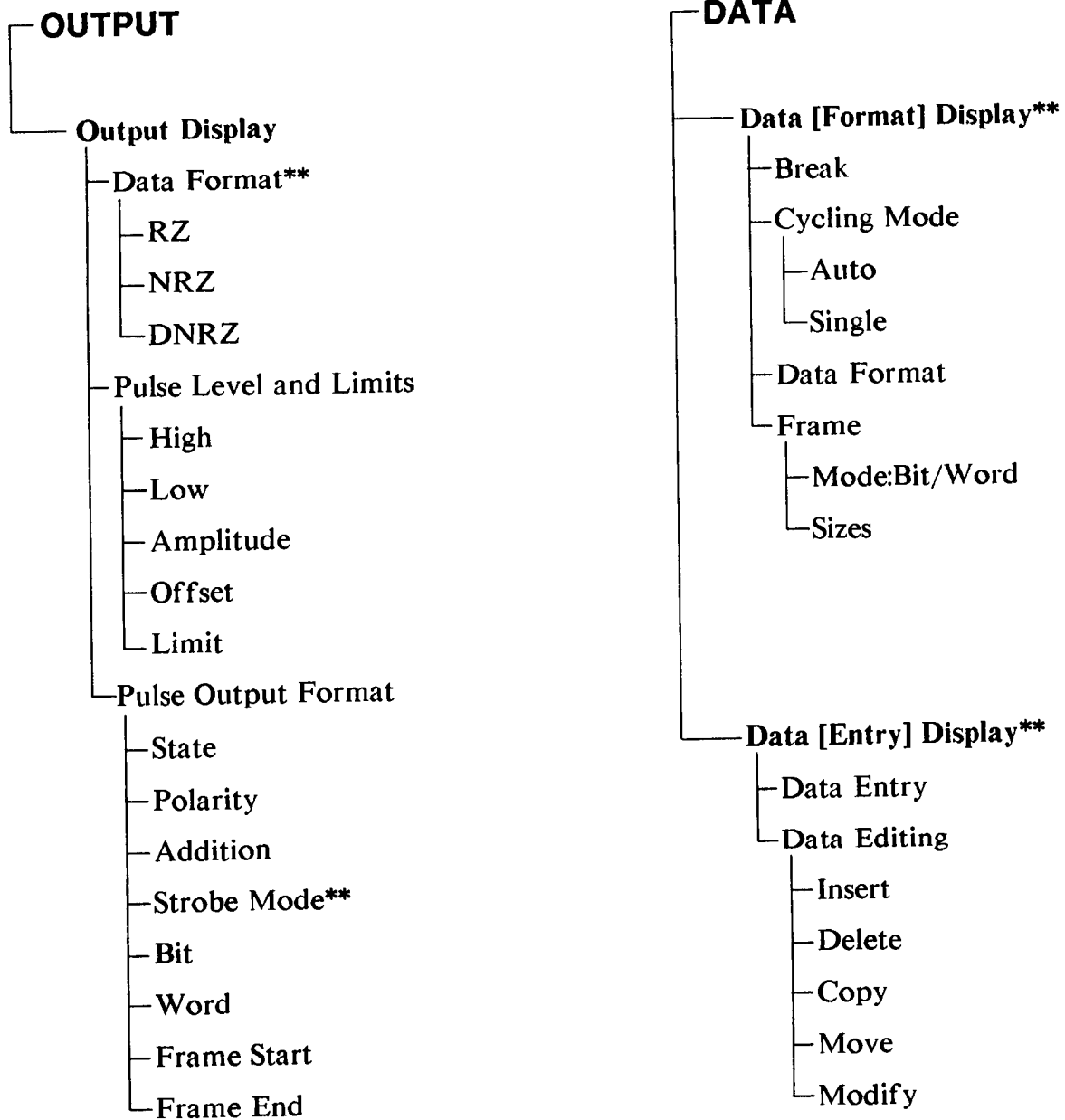

* In Controller Mode only

** Pattern Generator only

STEP BY STEP

programming steps of the data stream example

1 CONFIGURATION SETUP

Data streams are programmed in the Pulse-Pattern-Mode.

1-Press the SYSTEM-key and you get the

System [Configuration] -display

2-Select Pattern Generator with ROLL-keys

The display will show the specifications of the chosen configuration.

System [PULSE] -----ROLL to Change Configuration-----

Pulse Generator (PULSE)

Pulse Pattern Generator Specification

Memory Space	: 16384 Bit
Max. Pattern Rate	: 100 MBit/s NRZ
Var. Transition	: 6.5 ns ... 95 ms
Output Voltage	: 100 mVpp ... 16 Vpp into 50 Ohm
Channels	: 2

STEP BY STEP

2 DATA INPUT

The instrument has two displays where the input for the Data is made.

2a DATA FORMAT INPUT

1-Press the DATA-key and you get the

Data [Format] -display

2-Move cursor with the CURSOR-keys to the highlighted fields

Input of the Frame characteristics :

3-Select Frame Mode [Word] with [N/P]*

4-Set Word-Length 8 bit - Press 8

5-Set No. of Words 8 - Press 0, 0, 0, 8

Input of the Break point :

6-Select Break Mode [On] with [N/P]

7-Set Break-Bit 3 - Press 3

8-Set Break-Word 6 - Press 0, 0, 0, 6

9-Select Cycling Mode [Auto] with [N/P]

10-Select Data-Format Channel 1 [RZ]

with [N/P] keys

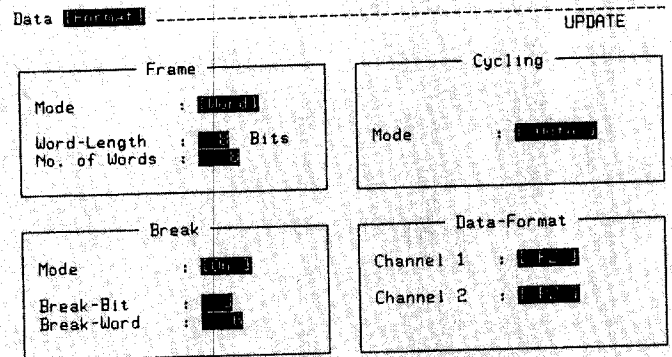

* [N/P] : [NEXT] , [PREV]-keys

STEP BY STEP

2b DATA ENTRY

After inputting the data formats, the data are programmed in the Data [Entry]-page.

1-Press the **DATA**-key to move the cursor to the top left

2-Select the Data [Entry]-display with [N/P]

Before you input the data, you may select the displayed channels and the data-base :

3-Move cursor with the **CURSOR**-keys

4-Select Display [Channel1] with [N/P]

5-Select Data Base [Hex] with [N/P]

6-Move cursor with the **CURSOR**-keys to the data entry area into the field Word 0 of Ch 1 .

7-Use the **KEYPAD** to type in the data :

A , 8 , 0 , 9 , 3 , D , F , 1 , 5 , 4 , 2 , B , 6 , E , 1 , 0

In this data entry area you can move the cursor up or down with the **ROLL**-keys only.

```
Data [Entry] ----- UPDATE
Display [Channel 1] Base: [Hex] Cursor on Word : [1]
Words : 8 Cursor on Digit : [1]
Digits: 2
----- Channel 1 -----
Word Digit → 0
↓ 0 A8
1 09
2 3D
3 F1
4 54
5 2B
6 6E
7-
```

Note: Datastreams in the 'output' memory are ready to output. All the new data we just entered are currently stored in a 'pending' memory. To get it outputted, an update of the 'output' memory is necessary.

8-Press the **BLUE (Shift)**-key and the **EXEC**-key to activate the update

STEP BY STEP

3 TIMING INPUT

Your data stream timing settings will be done in this step. For the input of the delay, you have to take the instruments fixed delay (main outs vs. trigger out: 75 ns) into account. So you have to add that to the wanted data stream delay of 50 ns vs. the strobe channel, which then leads to an input value of 125 ns.

- 1-Press the **TIMING**-key and you will get the **Timing [Pattern]** -display
- 2-Move cursor with the **CURSOR**-keys
- 3-Set Period 100 ns -press 1, 0, 0, .
Select time-unit [ns] with [N/P]-keys
- 4-Set Ch1 Delay 125 ns -press 1, 2, 5, .
- 5-Set Ch1 Width 30 ns -press 3, 0, ., 0
- 6-Set Strobe Width 60 ns -press 6, 0, ., 0

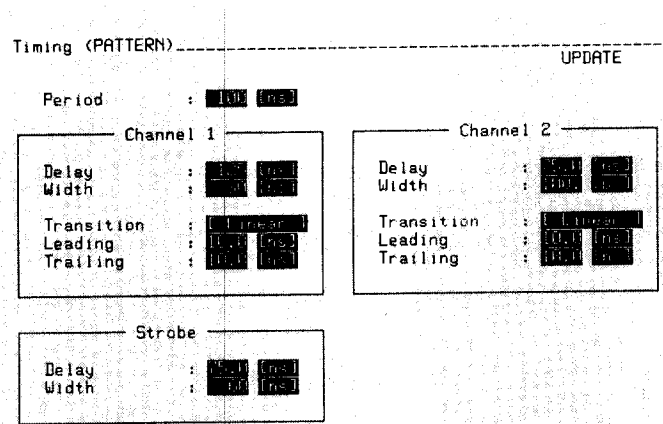

CONTROL

If you want to use the HP 8118A in an ATE system, where a system clock synchronizes the whole measurement process, you can set the instrument to **External Clock Mode** in Pattern Configuration. Furthermore all parameters are programmable, except the period.

- 1-Press **CONTROL** to get the **Control**-display
- 2-Move the cursor with the **CURSOR**-keys
- 3-Select External Clock State [On] with [N/P]

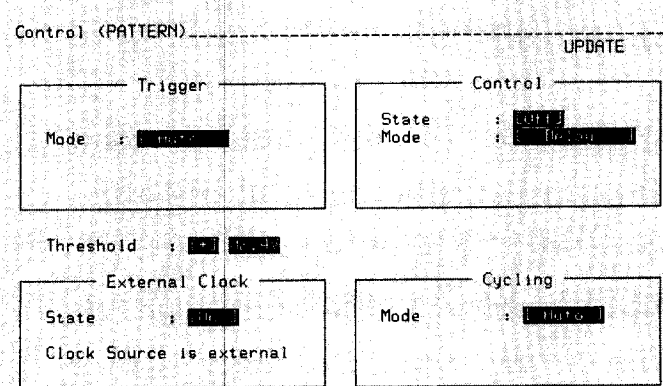

STEP BY STEP

4 OUTPUT SETTING

In the **Output**-page the required pulse parameter values of the data stream are programmed. During outputting of the signal it is possible to vary these parameters.

1-Press the **OUTPUT**-key and the

Output-display will be shown

2-Move cursor with the **CURSOR**-keys

3-Set Ch1 State [On] with [N/P]-keys

4-Set [High Level] +5V -press 5

5-Set [Low Level] -2V -press 2

and select [-] with the [N/P]-keys

The shown Data Format [RZ] was already programmed in the **Data [Format]**-page.

5-Select Strobe Mode [Word] with [N/P]

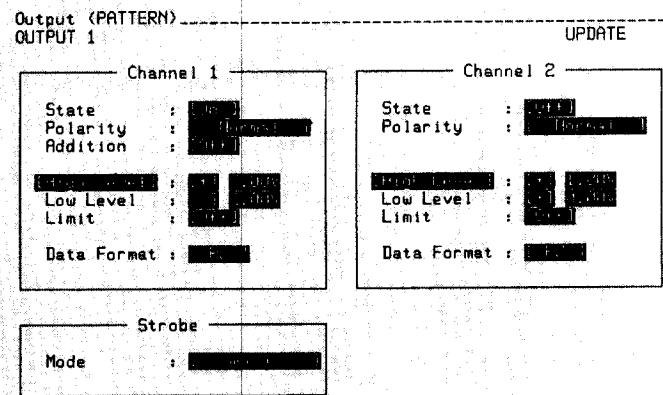

Having done all the previous steps, an update as shown in the **Data Entry** page (2b, 8) is necessary.

The datastream is ready now for outputting. Just press the **START**-key to activate the data stream-output.

During entering of a data stream, programming errors can occur, they will be shown immediately. The HP 8118A offers the 'HELP'-capability, helpful information for solving the programming error is windowed on the current display depending on the cursor position. This 'HELP'-window can be requested with the **GREEN**-key.

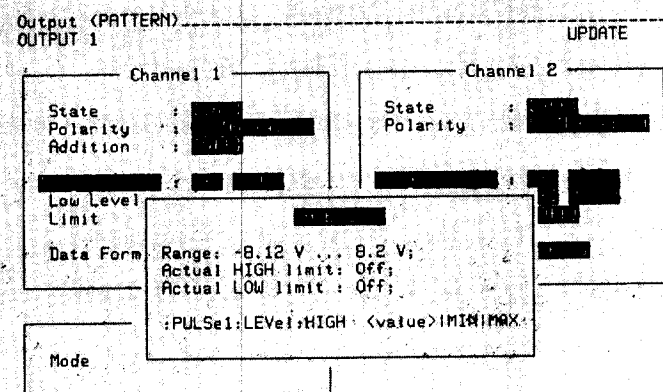

STEP BY STEP

5 DATA STREAM SAVING

5a PERIPHERAL SETUP

Before you can save the data on a disc, the instrument has to be set as the controller for the HP-IB bus and the peripherals have to be addressed.

- 1-Press two times the SYSTEM-key and select the System [Peripherals]-display with the [N/P]-keys
- 2-Move cursor with the CURSOR-keys
- 3-Set Printer Address 01 -Press 0, 1
- 4-Select [Graphics] print with [N/P]
- 5-Set Disk Address 7 -Press 7
- 6-Select Disk Unit [0] with [N/P]-keys
- 7-Set HP-IB Address 18 -Press 1, 8
- 8-Select HP 8118A is [Controller] at the HP-IB-bus with the [N/P]-keys

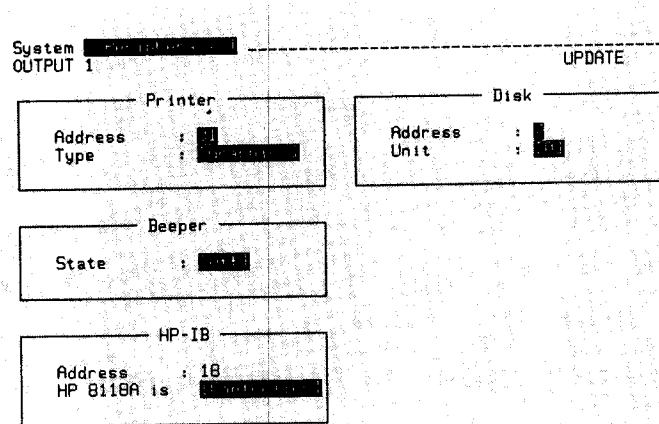

STEP BY STEP

5b SAVE INTERNALLY

Just choose the location and the description if you want to save the setting internally.

1-Press the SAVE-key to get the

Save [Internal]-display

2-Move the cursor with the CURSOR-keys to the Save Input area

3-Select Operation [Save] with [N/P]-key

4-Choose Location ,e.g.00, -Press 0, 0

5-Input the description with the ABC-line

How to use the ABC-line :

Press the BLUE-key and CURSOR <- or ->

to select the letter and then press the

BLUE-key and CURSOR ↑ to transfer

the letter into the description line.

6-Press the EXEC-key for activating the storage

The current Save Location can be changed with the ROLL-keys.

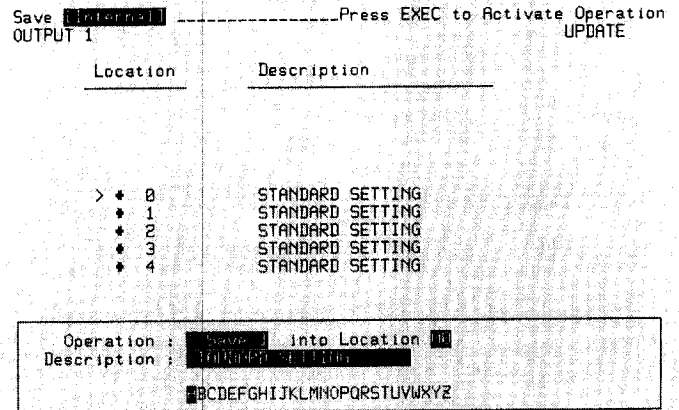

STEP BY STEP

5c SAVE EXTERNALLY

To store the data externally, it is necessary to set the File Name and a File Description.

1-Press the SAVE-key and then select the Save [External]-display with [N/P]-keys
Note: If Internal is not in brackets you have to go back to System [Peripherals]-display and to check for HP 8118A is [Controller] in the HP-IB segment.

2-Move the cursor with the CURSOR-keys to the file operation area

3-Select Operation [Save] with [N/P]-keys

4-Choose the File Name... with ABC-line
(see page II-7, How to use ABC-line)

5-Choose File Description... with ABC-line

6-Press the EXEC-key for activating the storage

The current Save Location can be changed with the ROLL-keys.

Save [External] -----Press EXEC t

Disc type : 9121 Bus address : 07
LIF volume : LB118A Disc unit : 0

File Name	File Description
USER1	USER SETTING
USER2	USER SETTING
>USER3	USER SETTING
USER4	USER SETTING
USER5	USER SETTING
USER6	USER SETTING

Operation :	File
Name :	
Description :	BCDEFGHIJKLMNOPQRSTUVWXYZ

DEVICE COMMANDS

COMMAND HIERARCHY (TREE)

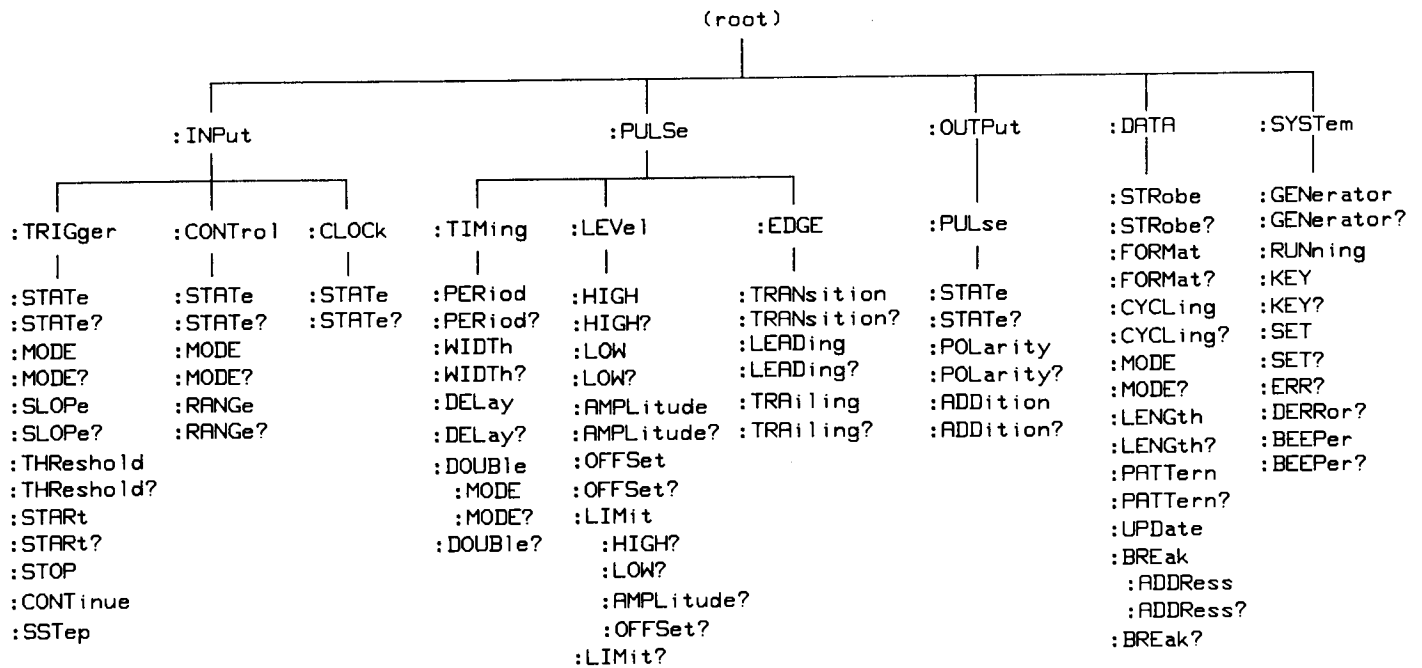

SYNTAX DIAGRAM CONVENTIONS

The instrument accepts character strings in upper or lower case equally.
Short and long forms of the commands are allowed.

MIN	=	minimum value
MAX	=	maximum value
value	=	integer (12), decimal (88.5), exponential (99.5 E-9), (E-12, E-9, E-6, E-3 are allowed)
units	=	ps/PS , ns/NS , us/US , ms/MS , s/S uv/UV , mv/MV , v/V
	=	either or
wsp	=	white space, ASCII control characters and space

DEVICE COMMANDS

:INPut

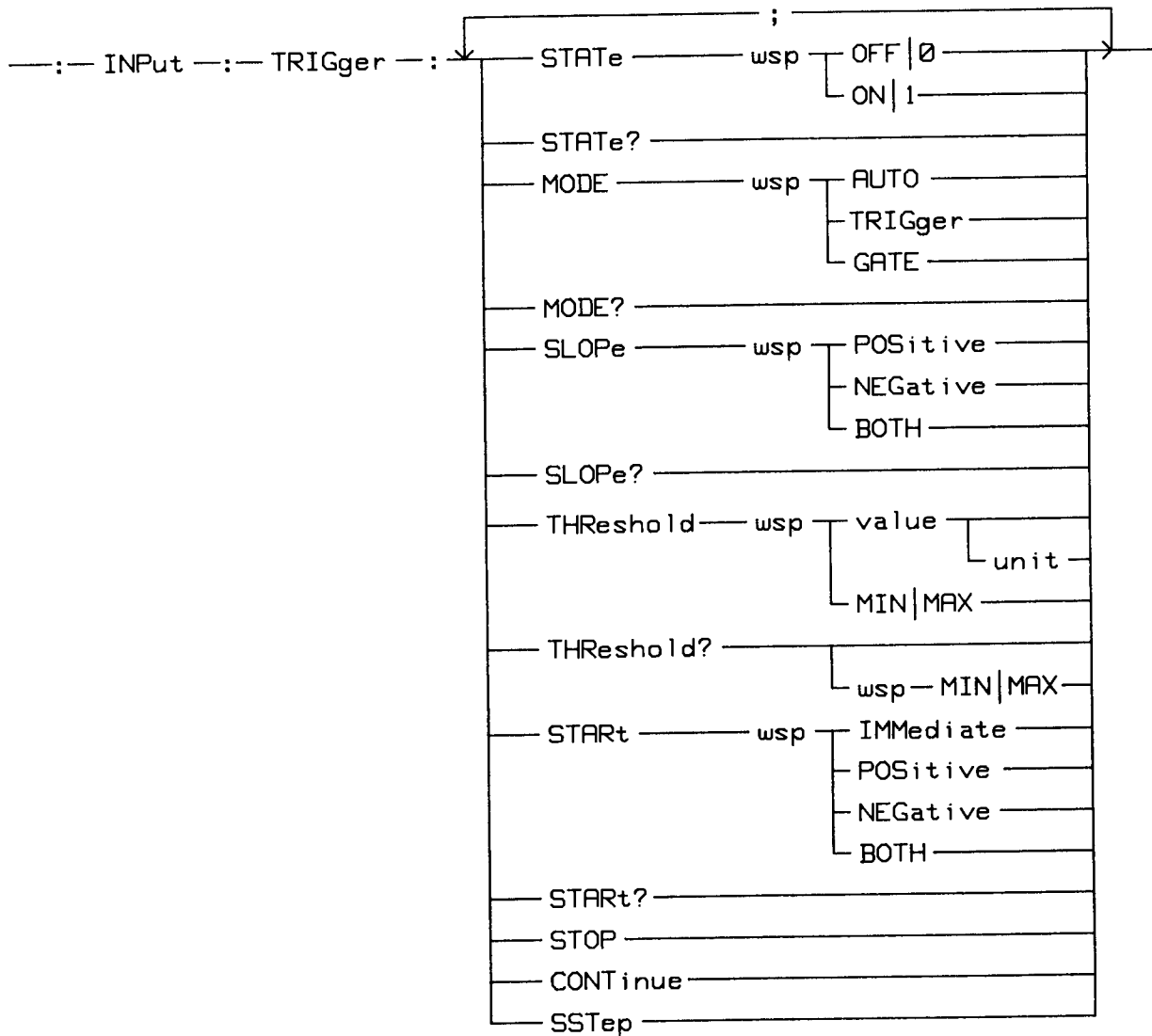

Note : :INPut:TRIGger:SSTep (=Single Step)
STOP the Pattern Generator first

DEVICE COMMANDS

:INPut

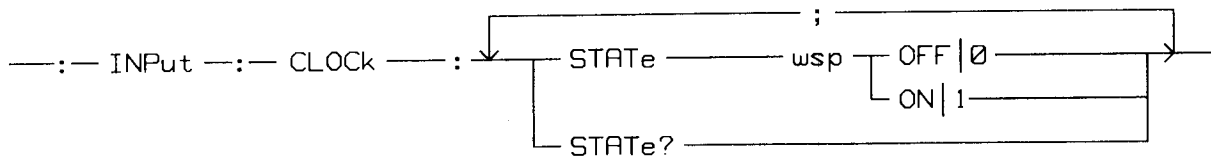
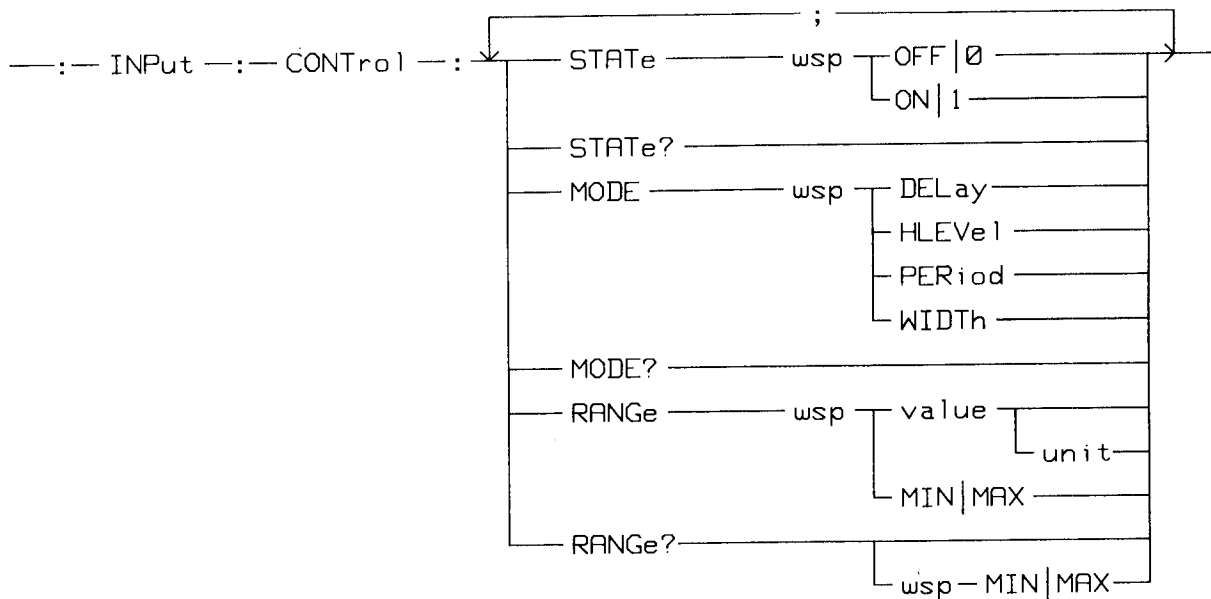

Note : `:INPut:CLOCK:STATE 0|1`
 STOP the Pattern Generator first

DEVICE COMMANDS

:PULSe

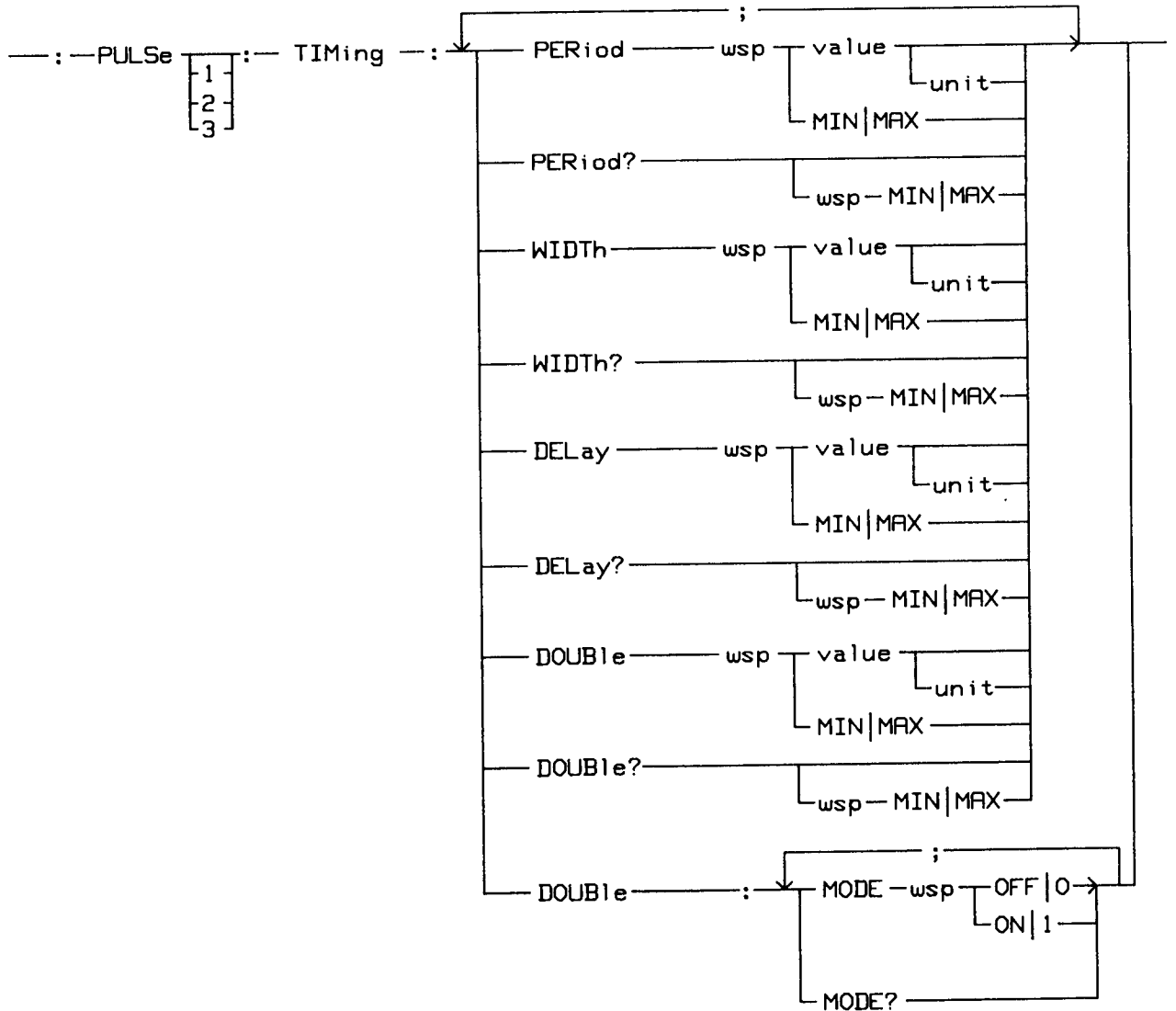

Note : :PULSe 1|2|3
 1 = Channel 1, 2 = Channel 2, 3 = Strobe Channel

DEVICE COMMANDS

:PULSe

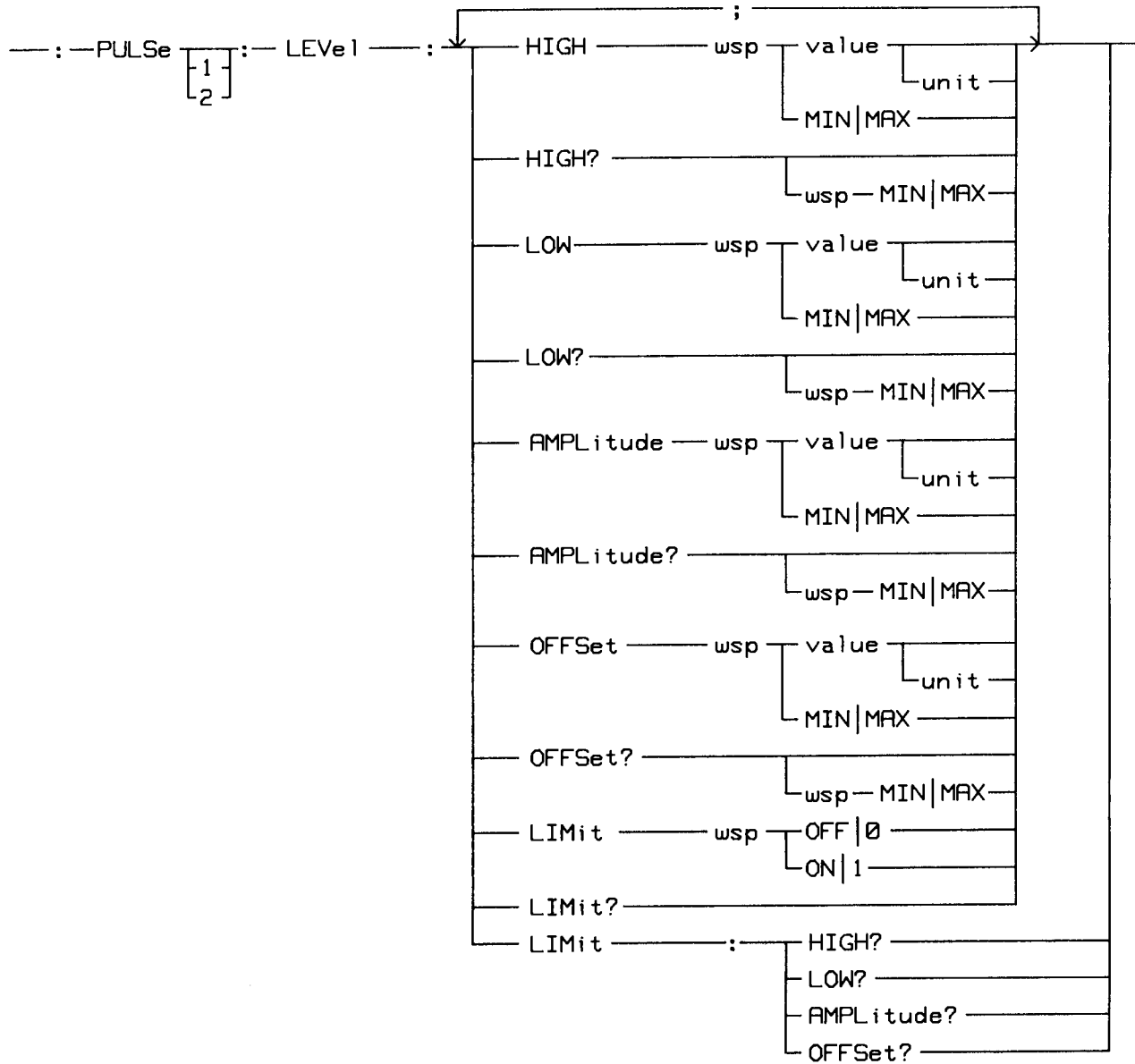

Note : :PULSe 1|2
 1 = Channel 1, 2 = Channel 2

DEVICE COMMANDS

:PULSe

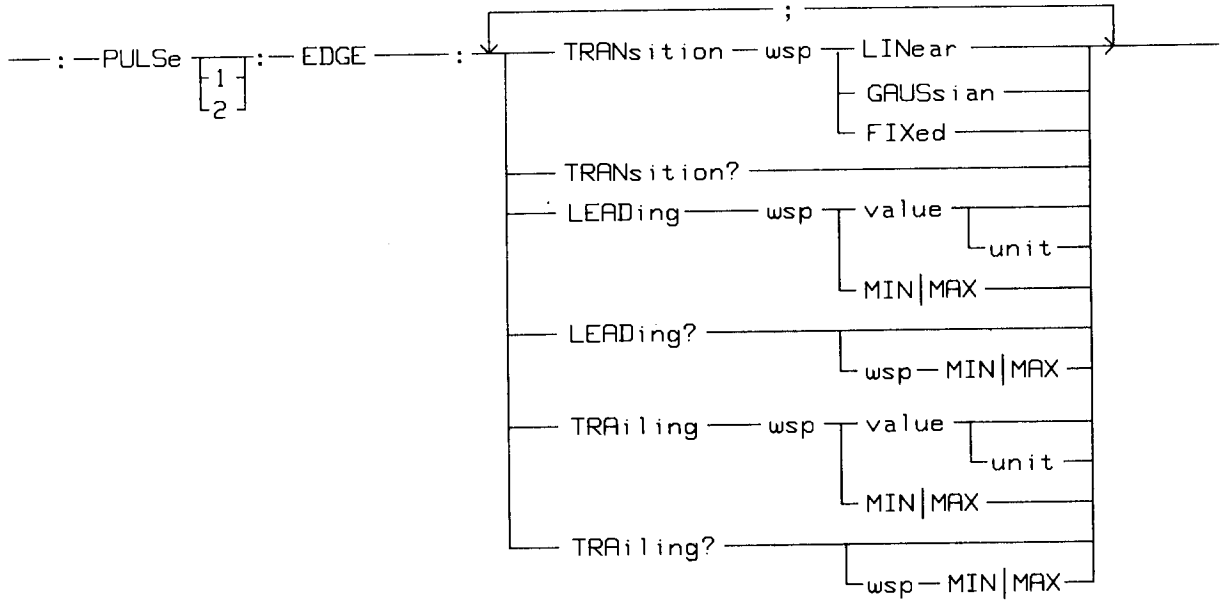

:OUTPut

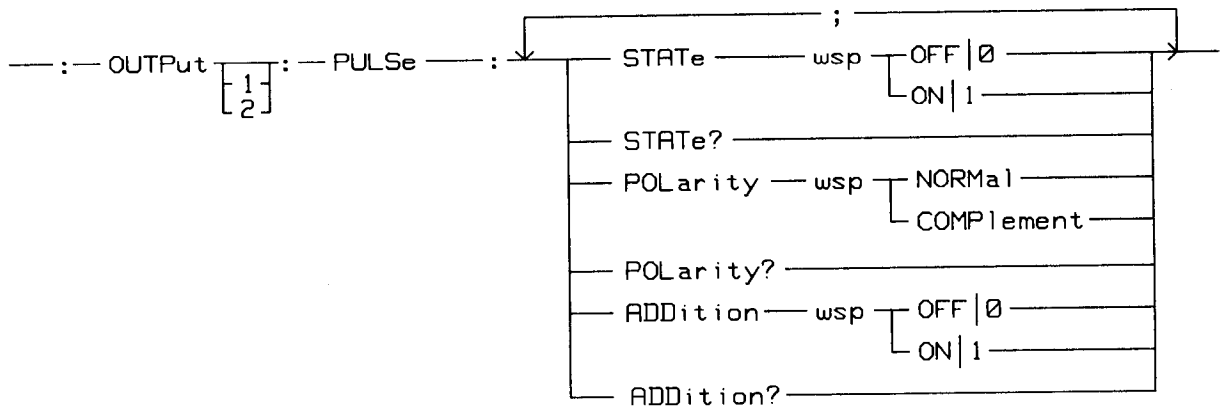

Note : :OUTPut 1|2
1 = Channel 1, 2 = Channel 2

DEVICE COMMANDS

:DATA

		STOP	UPDATE		
: DATA	1 2 3	STRobe	BIT	-	X
			WORD	-	X
			FSTart	-	X
			FEND	-	X
		STRobe?		-	-
		FORMat	RZ	X	-
			NRZ	X	-
			DNRZ	X	-
		FORMat?		-	-
		CYCLing	AUTO	-	-
			SINGLE	-	-
		CYCLing?		-	-
		MODE	WORD	-	X
			BIT	-	X
		MODE?		-	-
		LENGth	value 1 --,-- value 2	-	X
			value 3	-	X
		LENGth?		-	-
		PATtern	value --,--data	-	X
			data		
		PATtern?		-	-
			wsp -- BINary	-	-
			wsp -- OCTal	-	-
			wsp -- HEXadecimal	-	-
		UPDate		X	-
		BREak	OFF 0	-	X
			ON 1	-	X
		BREak?		-	-
		BREak	ADDRESS -- wsp	-	X
			value 1 --,--value 2	-	X
			value 3	-	X
		ADDRes?		-	-

- Notes :
- a :DATA 1|2|3
1 = Channel 1, 2 = Channel 2, 3 = Strobe Channel
 - b :DATA:MODE WORD|BIT
in Word Mode, value 1 = word length, value 2 = no. of words
in Bit Mode, value 3 = no. of bits
 - c :DATA:LENGTH value 1, value 2 or value 3 (see b)
 - d :DATA:BREAK:ADDRESS value 1, value 2 or value 3 (see b)

DEVICE COMMANDS

:SYSTEM

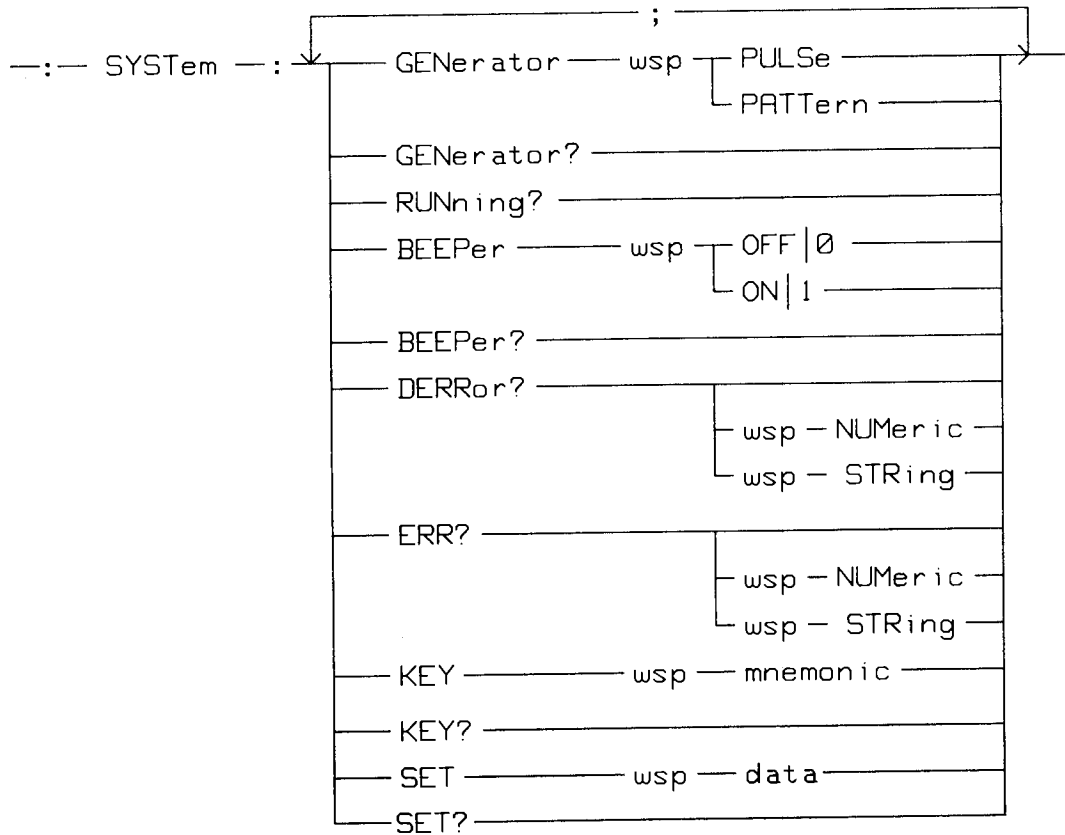

- Notes :
- a **:DERRor?** = device dependent error
 - :ERRor?** = oldest error
 - b **NUMeric** = numeric error code
 - STRing** = brief description of error
 - c **:SYSTEM:SET data**
STOP the Pattern Generator first



08118 - 90021

Printed in W.Germany