

**Agilent  
Arbitrary Waveform  
Generator**

**81180A**

**User's Guide**

## Notices

© Agilent Technologies, Inc. 2011

No part of this manual may be reproduced in any form or by any means (including electronic storage and retrieval or translation into a foreign language) without prior agreement and written consent from Agilent Technologies, Inc. as governed by United States and international copyright laws.

### Manual Part Number

81180-91020

### Edition

Fourth edition, December 2011

Printed in Germany

Agilent Technologies, Deutschland GmbH

Herrenberger Str. 130

71034 Böblingen, Germany

### For Assistance and Support

<http://www.agilent.com/find/assist>

### Limitation of Warranty

The foregoing warranty shall not apply to defects resulting from improper or inadequate maintenance by Buyer, Buyer-supplied software or interfacing, unauthorized modification or misuse, operation outside of the environmental specifications for the product, or improper site preparation or maintenance. No other warranty is expressed or implied. Agilent Technologies specifically disclaims the implied warranties of Merchantability and Fitness for a Particular Purpose.

## Warranty

**The material contained in this document is provided “as is,” and is subject to being changed, without notice, in future editions. Further, to the maximum extent permitted by applicable law, Agilent disclaims all warranties, either express or implied, with regard to this manual and any information contained herein, including but not limited to the implied warranties of merchantability and fitness for a particular purpose. Agilent shall not be liable for errors or for incidental or consequential damages in connection with the furnishing, use, or performance of this document or of any information contained herein. Should Agilent and the user have a separate written agreement with warranty terms covering the material in this document that conflict with these terms, the warranty terms in the separate agreement shall control.**

### Technology Licenses

The hardware and/or software described in this document are furnished under a license and may be used or copied only in accordance with the terms of such license.

### Restricted Rights Legend

If software is for use in the performance of a U.S. Government prime contract or subcontract, Software is delivered and licensed as “Commercial computer software” as defined in DFAR 252.227-7014 (June 1995), or as a “commercial item” as defined in FAR 2.101(a) or as “Restricted computer software” as defined in FAR 52.227-19 (June 1987) or any equivalent agency regulation or contract clause. Use, duplication or disclosure of Software is subject to Agilent Technologies’ standard commercial license terms, and non-DOD Departments and Agencies of the U.S. Government will receive no greater than Restricted Rights as defined in FAR 52.227-19(c)(1-2) (June 1987). U.S. Government users will receive no greater than Limited Rights as defined in FAR 52.227-14 (June 1987) or DFAR 252.227-7015 (b)(2) (November 1995), as applicable in any technical data.

## Safety Notices

### CAUTION

A **CAUTION** notice denotes a hazard. It calls attention to an operating procedure, practice, or the like that, if not correctly performed or adhered to, could result in damage to the product or loss of important data. Do not proceed beyond a **CAUTION** notice until the indicated conditions are fully understood and met.

### WARNING

A **WARNING** notice denotes a hazard. It calls attention to an operating procedure, practice, or the like that, if not correctly performed or adhered to, could result in personal injury or death. Do not proceed beyond a **WARNING** notice until the indicated conditions are fully understood and met.

# Safety Summary

## General Safety Precautions

The following general safety precautions must be observed during all phases of operation of this instrument. Failure to comply with these precautions or with specific warnings elsewhere in this manual violates safety standards of design, manufacture, and intended use of the instrument.

Agilent Technologies Inc. assumes no liability for the customer's failure to comply with these requirements.

Before operation, review the instrument and manual for safety markings and instructions. You must follow these to ensure safe operation and to maintain the instrument in safe condition.

## General

This product is a Safety Class 1 instrument (provided with a protective earth terminal). The protective features of this product may be impaired if it is used in a manner not specified in the operation instructions.

All Light Emitting Diodes (LEDs) used in this product are Class 1 LEDs as per IEC 60825-1.

## Environment Conditions

This instrument is intended for indoor use in an installation category II, pollution degree 2 environment. It is designed to operate within a temperature range of 5 – 40 °C (40 – 105 °F) at a maximum relative humidity of 80% and at altitudes of up to 2000 meters.

Refer to the specifications tables for the ac mains voltage requirements and ambient operating temperature range.

## Before Applying Power

Verify that all safety precautions are taken. The power cable inlet of the instrument serves as a device to disconnect from the mains in case of hazard. The instrument must be positioned so that the operator can easily access the power cable inlet. When the instrument is rack mounted the rack must be provided with an easily accessible mains switch.

## Ground the Instrument

To minimize shock hazard, the instrument chassis and cover must be connected to an electrical protective earth ground. The instrument must be connected to the ac power mains through a grounded power cable, with the ground wire firmly connected to an electrical ground (safety ground) at the power outlet. Any interruption of the protective (grounding) conductor or disconnection of the protective earth terminal will cause a potential shock hazard that could result in personal injury.

## Do Not Operate in an Explosive Atmosphere

Do not operate the instrument in the presence of flammable gases or fumes.

## Do Not Remove the Instrument Cover

Operating personnel must not remove instrument covers. Component replacement and internal adjustments must be made only by qualified personnel.

Instruments that appear damaged or defective should be made inoperative and secured against unintended operation until they can be repaired by qualified service personnel.

## Symbols on Instruments



Indicates warning or caution. If you see this symbol on a product, you must refer to the manuals for specific Warning or Caution information to avoid personal injury or damage to the product.



CE Marking to state compliance within the European Community: This product is in conformity with the relevant European Directives.



General Recycling Mark



Safety Mark of the Canadian Standards Association CSA .



N10149

C-Tick Conformity Mark of the Australian ACA for EMC compliance.

## Environmental Information



This product complies with the WEEE Directive (2002/96/EC) marketing requirements. The affixed label indicates that you must not discard this electrical/electronic product in domestic household waste.

Product category: With reference to the equipment types in the WEEE Directive Annexure I, this product is classed as a "Monitoring and Control instrumentation" product.

Do not dispose in domestic household waste.

To return unwanted products, contact your local Agilent office, or see

[www.agilent.com/environment/product/](http://www.agilent.com/environment/product/) for more information.

# Contents

<b>Contents</b> .....	<b>5</b>
<b>1 Introduction</b> .....	<b>13</b>
1.1 Introduction .....	14
1.2 Functional Description.....	20
1.3 Run Modes .....	26
1.4 Output Type.....	37
1.5 Output State .....	46
1.6 Programming the Model 81180A.....	46
<b>2 Configuring the Instrument</b> .....	<b>47</b>
2.1 Installation Overview .....	47
2.2 Unpacking and Initial Inspection .....	47
2.3 Safety Precautions .....	47
2.4 Performance Check.....	48
2.5 Power Requirements.....	48
2.6 Grounding Requirements .....	49
2.7 Long Term Storage or Repackaging for Shipment.....	49
2.8 Preparation for Use .....	50
2.9 Installation.....	50
2.10 Installing IVI Drivers.....	50
2.11 Controlling the Instrument from Remote .....	51
2.12 Connecting to a Remote Interface.....	51
2.13 Selecting a Remote Interface.....	52
2.13.1 GPIB Configuration .....	53
2.13.2 USB Configuration.....	54
2.13.3 LAN Configuration.....	57
2.14 Master Slave Operation.....	60
2.14.1 Connecting the Instruments.....	60
2.14.2 Resetting the Two Instruments .....	61

2.14.3	Selecting a Master .....	61
2.14.4	Operating Synchronized Instruments.....	62
<b>3</b>	<b>Features and Functions .....</b>	<b>63</b>
3.1	Overview .....	63
3.2	Inter-Channel Dependency .....	63
3.3	Output Termination .....	64
3.4	Input / Output Protection .....	64
3.5	Power On/Reset Defaults.....	64
3.6	Controlling the 81180A .....	66
3.7	81180A Front Panel Menus .....	68
3.7.1	Pulse Menus .....	71
3.7.2	Control Menus .....	72
3.8	Enabling the Outputs .....	75
3.9	Selecting a Function Shape .....	76
3.10	Changing the Output Frequency .....	76
3.11	Changing the Sample Clock Frequency .....	77
3.12	Selecting an Output Couple.....	78
3.13	Programming the Amplitude and Offset.....	79
3.14	Programming the Output Power .....	81
3.15	Selecting a Run Mode .....	82
3.15.1	Continuous Run Mode.....	83
3.15.2	Triggered Run Mode .....	84
3.15.3	Gated Run Mode.....	88
3.15.4	Abort.....	89
3.16	Using the Manual Trigger .....	90
3.17	Using the SYNC Output.....	90
3.18	Synchronizing Channel 1 and Channel 2 .....	91
3.19	Controlling Cross-Channel Propagation .....	93
3.20	Using External Clock References.....	94
3.20.1	Using an External SCLK Source .....	94
3.20.2	Using an External Clock Reference Source .....	96

3.21	Generating Standard Waveforms .....	97
3.21.1	Sine Wave.....	98
3.21.2	Triangle Wave .....	99
3.21.3	Square Wave.....	100
3.21.4	Ramp Wave .....	101
3.21.5	Sinc Wave.....	103
3.21.6	Gaussian Wave.....	104
3.21.7	Exponential Wave.....	105
3.21.8	DC Wave .....	106
3.21.9	Noise Wave.....	106
3.21.10	Standard Waveforms and Run Mode Options.....	107
3.22	Generating Arbitrary Waveforms.....	109
3.22.1	What Are Arbitrary Waveforms? .....	110
3.22.2	Generating Arbitrary Waveforms.....	110
3.22.3	Arbitrary Waveforms and Run Mode Options .....	115
3.23	Generating Sequenced Waveforms.....	117
3.23.1	What are Sequenced Waveforms?.....	118
3.23.2	Sequence Table Elements.....	121
3.23.3	Selecting Sequence Advance Mode .....	123
3.23.4	Sequences and Run Mode Options.....	125
3.23.5	Using Advanced Sequencing.....	129
3.24	Generating Modulated Waveforms .....	131
3.24.1	Off.....	132
3.24.2	AM .....	133
3.24.3	FM .....	135
3.24.4	Sweep.....	137
3.24.5	Modulated Waveforms and Run Mode Options .....	139
3.25	Generating Pulse Waveforms.....	141
3.25.1	Pulse Parameters .....	143
3.25.2	Pulse Modes.....	145
3.25.3	Programming Pulse Polarity .....	149
3.25.4	Applying Linear Transitions.....	150
3.26	Pulse Design Limitations .....	155
3.27	Settings Conflict Errors.....	156
3.27.1	Amplitude Errors.....	157
3.27.2	Pulse Timing Errors.....	157

3.27.3	Pulse Linear Transition Errors.....	158
3.27.4	Pulse Delay Errors.....	158
3.27.5	General Pulse Errors.....	159
3.28	Using Markers.....	159
3.29	Using Store/Recall.....	161
3.29.1	Storing Instrument Setups and Waveforms.....	162
3.29.2	Recalling Instrument Setups and Waveforms.....	163
3.29.3	Listing Storage Memory Contents.....	165
3.29.4	Store/Recall Considerations.....	166
3.29.5	Store/Recall Messages.....	167
<b>4</b>	<b>Programming Reference .....</b>	<b>169</b>
4.1	What's in this Chapter.....	169
4.2	Introduction to SCPI.....	169
4.3	Command Format.....	170
4.4	Command Separator.....	170
4.5	The MIN and MAX Parameters.....	171
4.6	Querying Parameter Setting.....	171
4.7	Query Response Format.....	171
4.8	SCPI Command Terminator.....	172
4.9	IEEE-STD-488.2 Common Commands.....	172
4.10	SCPI Parameter Type.....	172
4.10.1	Numeric Parameters.....	172
4.10.2	Discrete Parameters.....	173
4.10.3	Boolean Parameters.....	173
4.10.4	Arbitrary Block Parameters.....	173
4.10.5	Binary Block Parameters.....	173
4.11	SCPI Syntax and Styles.....	174
4.12	81180A Commands.....	174
4.12.1	Channel & Group Control Commands.....	183
4.12.2	Run Mode Commands.....	187
4.12.3	Analog Output Control Commands.....	198
4.12.4	Marker Output Control Commands.....	209
4.12.5	Standard Waveforms Control Commands.....	213



4.12.6	Arbitrary Waveforms Control Commands .....	217
4.12.7	Sequenced Waveforms Control Commands .....	228
4.12.8	Advanced Sequencing Control Commands .....	237
4.12.9	Modulated Waveforms Global Control Commands .....	243
4.12.10	Modulation Control Commands .....	244
4.12.11	AM Programming .....	245
4.12.12	FM Programming .....	247
4.12.13	Sweep Modulation Programming .....	248
4.12.14	Pulse Waveform Programming .....	251
4.12.15	LAN System Configuration Commands .....	261
4.12.16	Store/Recall Commands .....	265
4.12.17	System Commands .....	268
4.13	LAN, USB and GPIB Programming Considerations .....	269
4.14	Error Messages .....	280
4.15	IEEE-STD-488.2 Common Commands and Queries .....	284
<b>5</b>	<b>Performance Verification .....</b>	<b>287</b>
5.1	What's in This Chapter .....	287
5.2	Performance Checks .....	287
5.3	Environmental Conditions .....	288
5.4	Warm-up Period .....	288
5.5	Initial Instrument Setting .....	288
5.6	Recommended Test Equipment .....	288
5.7	Test Procedures .....	289
5.8	Frequency Accuracy .....	290
5.8.1	Frequency Accuracy, Internal Reference .....	290
5.8.2	Frequency Accuracy, External 100 MHz Reference .....	291
5.8.3	Frequency Accuracy, External Sample Clock .....	291
5.8.4	Phase Noise Test .....	292
5.8.5	Amplitude Accuracy .....	293
5.8.6	Amplitude Accuracy, Direct DAC Output .....	293
5.8.7	Amplitude Accuracy, DC Output .....	294
5.8.8	Power Accuracy, AC Coupled Output .....	294
5.9	Offset Accuracy .....	295
5.9.1	Offset Accuracy, Direct DAC Output .....	295

5.9.2	Offset Accuracy, DC Output.....	296
5.10	Square Wave Characteristics .....	297
5.10.1	Square Wave Checks, Direct DAC Output .....	297
5.10.2	Square Wave Checks, DC Output.....	297
5.11	Sinewave Characteristics.....	298
5.11.1	Sinewave Spectral Purity, DAC Output.....	298
5.11.2	Sinewave Spectral Purity, DC Output .....	300
5.11.3	Sinewave Spectral Purity, AC Output .....	301
5.11.4	Sinewave Flatness, AC Output.....	303
5.12	Inter-Channel Propagation Characteristics.....	304
5.12.1	Offset Between Channels .....	304
5.12.2	Skew Between Channels .....	305
5.13	Run Mode Tests.....	306
5.13.1	Continuous Run Mode Test.....	306
5.13.2	Triggered Run Mode Test .....	307
5.13.3	Gated Run Mode Test.....	308
5.14	Trigger Inputs Tests .....	309
5.14.1	Front Panel Trigger Input Test .....	309
5.14.2	Rear Panel Event Input Test.....	311
5.14.3	Delayed Trigger Characteristics.....	312
5.14.4	Timed Internal Trigger Tests .....	313
5.14.5	Delayed Internal Trigger Tests.....	313
5.15	Marker Output Characteristics.....	314
5.15.1	Marker Output and Level Checks .....	314
5.15.2	Marker Delay Checks.....	315
5.15.3	Marker Position Checks .....	316
5.15.4	Marker Width Checks.....	318
5.16	SYNC Output Operation.....	319
5.16.1	SYNC Output – Pulse.....	319
5.16.2	SYNC Output - WCOM.....	319
5.16.3	SYNC Source .....	320
5.16.4	SYNC Position Checks.....	321
5.16.5	SYNC Width Checks .....	322
5.17	Waveform Memory Operation .....	322
5.17.1	Waveform Memory .....	323
5.17.2	Internal Waveform .....	324

5.17.3	Dynamic Waveform Control.....	324
5.18	Sequence operation .....	325
5.18.1	Continuous Sequence - Auto Advance Mode .....	325
5.18.2	Continuous Sequence - Once Advance Mode.....	326
5.18.3	Continuous Sequence - Stepped Advance Mode .....	328
5.18.4	Triggered Sequence - Auto Advance Mode.....	329
5.18.5	Triggered Sequence - Once Advance Mode .....	330
5.19	Advanced Sequence operation .....	332
5.19.1	Continuous Advanced Sequence - Auto Advance Mode .....	333
5.19.2	Continuous Advanced Sequence - Once Advance Mode.....	334
5.19.3	Continuous Advanced Sequence - Stepped Advance Mode .....	336
5.19.4	Triggered Advanced Sequence - Auto Advance Mode.....	337
5.19.5	Triggered Advanced Sequence - Once Advance Mode .....	339
5.19.6	Triggered Advanced Sequence - Stepped Advance Mode....	340
5.20	Remote Interfaces .....	341
5.20.1	GPIB Control.....	342
5.20.2	USB Control.....	342
5.20.3	LAN Control.....	343
5.21	Updating 81180A Firmware.....	343



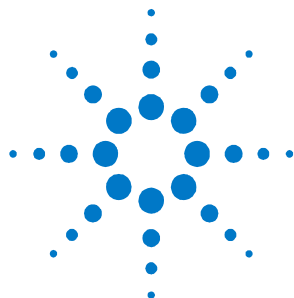

# 1 Introduction

## What's in This Chapter

This chapter contains a general description of the **Model 81180A Waveform Generator**, including an overall functional description of the instrument. Additionally, the front and rear panel connectors and indicators are explained in detail.

---



This manual is shared by both single and dual channel versions. Therefore, if you purchased the Model 81180A-116, please ignore all references to the second channel in this manual.

---

## Conventions

The icon...	Indicates...
	A note or important information.
	A tip
	A caution or warning
	Notes within a table

---

## Safety Symbols

The icon...	Indicates...
	Alternating current
	Standby supply. Unit is not completely disconnected from ac mains when switch is off.

---

## 1.1 Introduction

### 81180A Feature Highlights

Dual output configuration with independent waveform control  
Tight phase offset control between channels (10 ps resolution)  
Operational in each of the following modes:

- Function generator
- Arbitrary waveform generator
- Modulation generator
- Sequence generator
- Pulse generator

12 Bit vertical resolution

1 ppm clock stability

Extremely low- phase noise-carrier

16 M waveform memory, optional 64 M waveform memory

2 V<sub>p-p</sub> into 50Ω, double into open circuit

Interrupted run modes such as, re-triggered and delayed trigger

Complex sequences link and loop segments in user-definable order

4" high resolution color LCD display

Ethernet, USB and GPIB interfaces

Two-instrument synchronization, jitter-free and phase control

Remote calibration without removing case covers

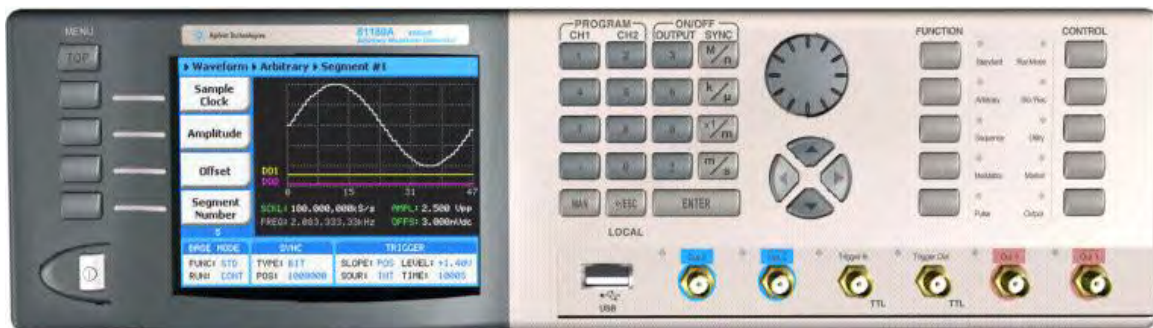

Figure 1-1: Model 81180A

### Introduction

Detailed functional description is provided, following the general description of the features and functions available with the **Model 81180A**.

- General** The **Model 81180A** is a dual-channel universal waveform source. In addition to its standard ability to generate arbitrary shapes, functions or modulation, it can also be used as a full-featured pulse generator, as well as a wireless signal source. The **81180A** offers unmatched performance, even when compared to instruments designed to generate fewer types of signals. Its affordable footprint saves space and cost without compromising bandwidth and signal integrity. Cutting-edge technology is utilized to assure that this will be the only source needed for many years to come.
- 
- Two Synchronized Channels** The **81180A** has two output channels, both of which can operate either independently, or synchronized to share the same sample clock source. As two separate channels, one has the advantage of having two separate instruments in one box, with each having the ability to be programmed to output different function shapes, amplitude levels and/or to operate in different run modes. Alternatively, the advantage of having two synchronized channels is very significant in applications that require an accurate and controlled phase between the two channels. Many applications require X-Y modes and I&Q outputs and the **81180A** is ideal for this usage.
- 
- Stable and Accurate Output Signals** As standard, the instrument is equipped with a frequency reference that has 1ppm accuracy and stability over a period of 1 year. An external frequency reference input is provided on the rear panel for applications requiring greater accuracy and stability.
- 
- Signal Integrity** As technology evolves and new devices are continuously developed, faster and more complex signals are needed to simulate and stimulate these new devices. The **81180A** has the highest bandwidth in its class, enabling it to accurately duplicate and simulate high frequency test signals. With its wide sample clock generator range (up to 4.2 GSa/s), 12-bit vertical resolution, 2 V<sub>p</sub> and over 600 MHz output bandwidth, it is simple to create mathematical profiles, download the coordinates to the instrument and regenerate waveforms without compromising signal fidelity or system integrity.
- 
- DC or AC Coupled Outputs** The **81180A** offers two output amplifiers: DC, which is output differentially and AC, which is single-ended. The DC path is available for applications where transitions and aberrations must be optimized, but bandwidth is limited. The AC path is available for applications requiring bandwidth and flatness for frequencies as high as 1,500 MHz.
-

**Versatile Run Modes** Having a waveform generator that has such an enormous waveform creation capability without the ability to control how waveforms start and stop is unlikely to perform as desired in a real-life environment. For this purpose, the **81180A** is equipped with a highly sophisticated mechanism that allows precise control over the start and stop timing, which is exactly what is required for interactive systems. When the instrument is operated on the bench, most applications require that the output is generated continuously or triggered from an external source, but as a system component and as part of a large array of other equipment, the waveform can be halted for a specified time, then operated for another period of time and stopped when it is no longer required. The enable/disable sequence is available when the **81180A** is placed in armed remote operation only and the start and stop commands can be programmed to come through different inputs.

Besides armed operation, the waveform generator responds to various trigger sources such as: external trigger signal from the trigger input, button press on the front panel, external signal which is applied through the event input and finally, if none of the external stimuli are available, an internal trigger generator with a programmable trigger period can be utilized to generate repeated triggers.

As well as the above-described trigger facilities, the **81180A** has two additional trigger modes that enhance its performance. The first is an override mode, where each trigger stops the running waveform and overrides the output to start over, and the second is a re-trigger mode, where the stop of the waveform triggers the next start after a predefined and programmable interval. While the first mode assures that every trigger starts a new cycle, the second mode assures that no new cycle is initiated before the previous cycle has been completed and a pre-programmed interval has lapsed before the next cycle is started.

Besides its trigger facilities, the **81180A** can be gated to generate waveforms only when a specific level of the trigger input is reached. It also can be programmed to generate a counted burst of waveform cycles upon request, whether it comes from a trigger signal or from a remote command.

The **81180A** also employs a delay circuit, where an external event triggers a delay which only after its programmed interval, the output is allowed to start generating waveforms.

Finally, to make sure no trigger slips away; the **81180A** has a smart trigger detection that inhibits triggers if they are below or above a certain trigger pulse width and also holds off all triggers that are considered false, before the true signal appears and does the work.

---



**Arbitrary Waveforms and Memory Segmentation** Waveform memory is the internal scratchpad where the waveforms reside. Larger memory banks provide for longer waveforms. One can use the entire memory for a single waveform or split the length to smaller segments. In this case, many waveforms can be stored in the same memory and replayed, one at a time, when recalled to the output. The memory segmentation feature may be combined with a sequence generator that can take different memory segments and link and loop them in any order as required for the specific application or test. The ability to loop waveform segments in a sequence can save a lot of memory and thus extend the capability of the generator to produce longer, more complex waveforms. Each of the **81180A** channels can be programmed to have a unique setting of sequence steps and loops.

---

**Dynamic Segment / Sequence Control** A control input is available on the **81180A** rear panel that provides control over the replay of a specific memory segment. The control connector has 9 pins and hence allows replay of one of 256 waveform segments. A valid line must be asserted to validate segment change. Having the dynamic control feature, in effect, can serve as replacement of the sequence table where the real-time application can decide when and for how long a waveform will be generated. For much more complex applications, this same input may serve as a dynamic switch for complete sequences and thus create real-life scenarios for real-time applications.

---

**Built-in Waveform Gallery** Care to use the instrument as a function generator? No need to calculate complex waveforms, as the **81180A** does the work for you. Select the standard waveforms button and start generating any of ten waveforms that are pre-computed and available for immediate use. Included are: sine, triangle, square, pulse, ramp, sinc and others. Remember that waveforms are created from sampled waveform points, and therefore some of the waveforms cannot be generated above certain frequencies, where the number of points is insufficient to draw a perfect shape. Nevertheless, by using advanced techniques, the **81180A** generates standard sine and square waveforms at frequencies up to 250 MHz.

---

**Wireless Waveforms** Wireless communication, with its continuous evolution, emerging standards, and increasing bandwidth and complexity is an area where traditional generators often require replacement or upgrading in order to keep up with modern applications. The **81180A**, combined with the power of the optional wireless signal software package, creates the most flexible and powerful wireless signal generation tool available. Define and analyze virtually any test stimulus, whether it be at baseband, IF or RF frequencies, with a choice of analog or digital. Using the **81180A** with the wireless signal tool, you can

generate baseband I & Q, IF that are fed directly to an up-converter, or even RF signals.

---

**Pulse Waveforms** Need to generate accurate and jitter-free pulses? Just set the main operating mode to pulse generator and the instrument will be transformed into a full-featured pulse generator. Need to control pulse transitions and placement? Just program each channel to output pulses with linear or fast transitions and control-edge placement with SCLK ps resolution.

Further, if your application requires more than just a fixed duty cycle or programmable pulse width, then modulate and control your leading edge with any standard or arbitrary waveform shape. Combine all of these features with external pulse width control and you have an extremely versatile pulse generation tool.

While using the pulse generator, do not forget that the **81180A** is a digital instrument and as such, creates the pulses from a digital memory. Therefore, be sure to observe the limitations that have evolved in the creation of such an advanced instrument: while most of analog pulse generators can be emulated with the **81180A**, one should observe the number of points that are required to generate the pulse shape, and take into consideration the time that is required to compute and output the waveform.

---

**Local Operation** Operating the 81180A from the front panel is intuitive and extremely easy. A large and user-friendly 4" back-lit color LCD display facilitates browsing through menus, updating parameters and displaying detailed waveform information. Combined with a numeric keypad, cursor position control and a knob, the front panel controls simplify the operation of this universal waveform source.

---

**Remote Operation** Access speed is an increasingly important requirement for test systems. Ethernet, USB and GPIB interfaces are available so that the most suitable interface for the application may be selected. Remote control of instrument functions, parameters and waveform downloads is easily tailored to specific system environments, regardless of whether control is via a laptop computer or full-featured ATE system.

IVI drivers and factory support will speed up system integration and minimize test development time and costs.

---

**Remote Calibration** Normal calibration cycles in the industry range from one to three years, where instruments are sent to a service center, opened to allow access to trimmers, calibrated and certified for repeated usage. Leading-edge technology was

employed on the **81180A** to allow calibration from any **81180A** remote interface such as USB, GPIB or LAN. Calibration factors are stored in a flash memory, thus eliminating the need to open instrument covers.

---

**Manual Changes** Technical corrections to this manual (if any) are listed in the back of this manual on an enclosed MANUAL CHANGES sheet.

---

**Safety Considerations** The **Model 81180A** has been manufactured according to international safety standards. The instrument meets IEC 61010-1, EN61010-1, CSA C22.2 No. 61010-1 and UL 61010-1 (Safety requirements for electrical equipment for measurement, control, and laboratory use – Part 1: General requirements). It has a metal chassis that is directly connected to earth via the chassis power supply cable (Safety Class I).

Only qualified, service-trained personal should remove instrument covers. Always disconnect the power cable and any external circuits before removing the instrument cover. Any adjustment, maintenance and repair of an opened, powered-on instrument must be performed by authorized service personal. Do not use this product in any manner not specified by the manufacturer. The protective features of this product may be impaired if it is used in a manner not specified in the operation instructions.

---



When the 81180A is turned off with the front panel power switch, the instrument is placed in standby mode but is still connected to the mains. To disconnect the mains from the instrument, remove the power cord.

Do not remove instrument covers when operating the instrument or when the power cord is connected to the mains.

---

**Supplied Accessories** The instrument is shipped with a power cord, USB cable and product CD.

---

**Specifications** Instrument specifications are listed in Appendix A. These specifications are the performance standards or limits against which the instrument is tested. Specifications apply under the following conditions: output terminated into 50  $\Omega$  after 30 minutes of warm up time, and within a temperature range of 20°C to 30°C. Specifications outside this range are degraded by 0.1% per °C.

---

## 1.2 Functional Description

### Introduction

A detailed functional description is given in the following paragraphs. The description is divided into logical groups: front panel input and output connectors, rear panel input and output connectors, operating modes, run modes, output type, output state, synchronization, and front panel indicators.

---

### Front Panel Connectors and Indicators

The **Model 81180A** has six SMA connectors on its front panel: two for each main output, one used for accepting triggers and one for the SYNC output. Each connector on the front panel has a LED associated with it, indicating when the output or input is active (LED on), or when inactive (LED off). The function of each of the front panel connectors is described in the following paragraphs.

---

### Main Output - Channels 1 and 2

There are two connectors for each output channel, marked Normal and Inverted. When using the DC couple mode, the output is generated differentially through these two connectors. The AC couple mode is single-ended and consequently, only the Normal connector outputs AC signals. The main output connectors generate standard waveforms to 250 MHz, arbitrary waveforms with 4.2 GSa/s sampling rate, and sequenced waveforms that are made of arbitrary waveform segments. These outputs generate modulated and pulse waveforms, as well. Output source impedance is  $50\Omega$ , therefore the cable connected to this output should be terminated with  $50\Omega$  load resistance. For different load resistance, determine the actual amplitude from the following equation:

$$V_{\text{out}} = 2V_{\text{prog}} \left( \frac{50\Omega}{50\Omega + R_L} \right)$$

The output amplitude is doubled when the output impedance is above roughly  $10\text{ k}\Omega$ . Also, the output can be turned on and off. However, turning the output off stops the signal, but leaves low impedance on the output terminals.

---



For application safety reason, when the instrument is powered up, the outputs are always off. For the same reason, when front panel settings are recalled from a stored setup, the outputs are always off.

---

**SYNC Output**

The SYNC output generates single or multiple TTL pulses for synchronizing other instruments (i.e., an oscilloscope) to the output waveform. The SYNC signal always appears at a fixed point relative to the waveform. The location of the sync pulse along the waveform is programmable. Since there is only one SYNC output, the output is associated with the channel 1 output, but can be changed to be sourced and synchronized to channel 2.

Note that the SYNC output is also used as a frequency marker when the 81180A is set to generate one of the modulation functions.

---

**TRIG IN**

In general, the trigger input is used for stimulating output waveforms at the main output connector(s). The trigger input is inactive when the generator is in continuous operating mode. When placed in trigger, gated or burst mode, the trigger input is made active and waits for the right condition to trigger the instrument. The trigger input is edge sensitive, i.e., it senses transitions from high to low or from low to high.

Trigger level and edge sensitivity are programmable for the trigger input. For example, if your trigger signal rides on a dc level, you can offset the trigger level to the same level as your trigger signal, thus assuring correct the threshold for the trigger signal. The trigger level is adjustable from -5V to +5V.

The trigger input is common to both channels. Therefore, if one of the **81180A** channels is placed in trigger mode, the trigger input will affect this same channel. If both channels are placed in trigger mode the trigger input will affect both channels simultaneously.

---

**USB**

This connector accepts standard USB-1 disk-on-key memory sticks. The main purpose of this interface is to provide for external storage and download of setups and waveforms. This I/O cannot be used for controlling the instrument from remote.

---

**Front Panel Controls**

The front panel controls and keys are grouped in logical order to provide efficient and quick access to instrument functions and parameters. Refer to *Figure 1-2* throughout the following description to understand the purpose and effect of each front panel control.

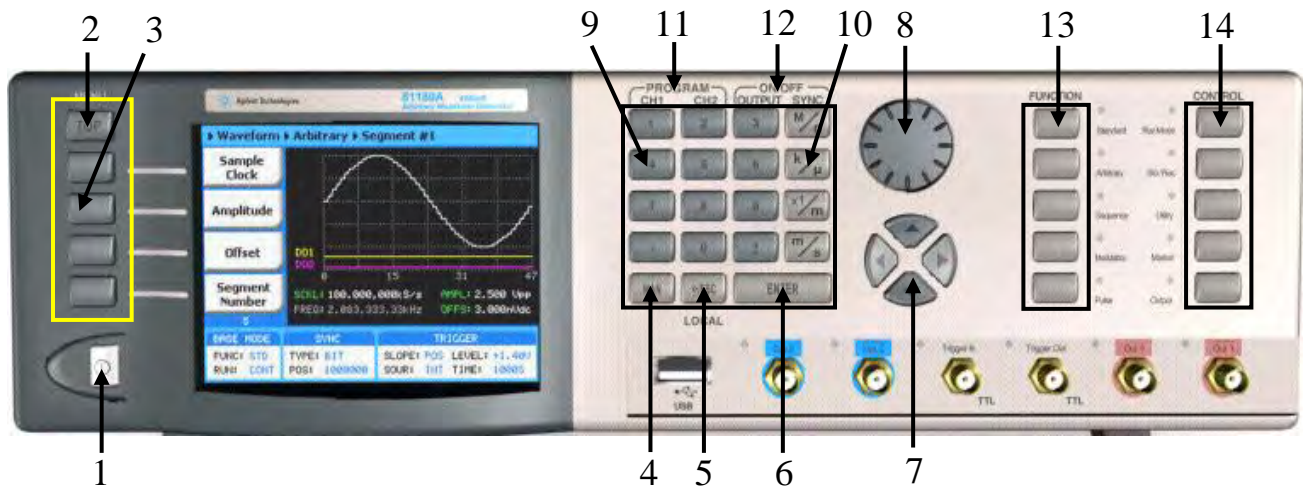

**Figure 1-2: 81180A Front Panel Controls**



The index in the following paragraphs point to the numbered arrows in the above figure.

1. *Power Switch* – Toggles **81180A** power ON and OFF
2. *Menu Top* – For certain functions, selects the root menu. This button is disabled during parameter editing
3. *Menu Soft Keys* – Select parameters to be audited. These buttons are disabled during parameter editing.
4. *MAN* – Manual trigger button, used in lieu of an external trigger signal.
5. *Esc (Local)* – Has two functions:
  - 1) When in edit mode, cancels edit operation, restores last value and returns to the main function screen
  - 2) When operating the **81180A** from a remote interface, none of the front panel buttons are active except the Local button. When depressed, it restores control to front panel buttons
6. *Enter* – Has two functions:
  - 1) When multiple parameters are displayed on the screen, the cursor and the dial scroll through the parameters. Pressing Enter selects the parameter for edit. After the parameter has been modified, the Enter button locks in the new variable and releases the buttons for other operations
  - 2) When a parameter is modified, Enter can be used to replace the x1 suffix key
7. *Cursor UP, Down, Left and Right* – Has two functions:
  - 1) When multiple parameters are displayed on the screen, the cursor and the dial scroll through the parameters

- 2) When a parameter is selected for editing, cursor buttons right or left move the cursor accordingly. Cursor buttons up or down modifies parameter value accordingly.
8. *Dial* – Has similar functionality as the cursor UP and Down keys.
9. *Numerical keypad* – These keys are used for modifying an edited parameter value.
10. *Parameter Suffixes (M/n, k/ $\mu$ , x1/m and m/s)* – These keys are used to place a suffix at the end of the parameter. They are also used for terminating an edit operation.
11. *Program CH1, CH2* – Use Program CH1 to modify the screen to display channel 1 parameters. Use Program CH2 to modify the screen to display channel 2 parameters. These keys can be used only when the **81180A** is not in edit mode
12. *ON/OFF Output, Sync* – These keys can be used only when the **81180A** is not in edit mode. The Output ON/OFF toggles output waveform, at the output connector, ON and OFF. The Sync ON/OFF toggles the sync waveform, at the SYNC output connector, ON and OFF
13. *Function* – These keys select one of 5 function menus that the **81180A** can generate. The output functions are: Standard, Arbitrary, Sequenced, Modulated and Pulse. A LED lights next to the selected function.
14. *Control* – These keys select control menus that program the 8110A operating modes. The control menus are: Run Mode, Store/Recall, Utility, Markers and Output.

## Rear Panel Input & Output Connectors

The **81180A** has a number of connectors on its rear panel. These connectors are described below. *Figure 1-3* shows rear panel plugs, indicators, connectors and other parts.



**Figure 1-3: 81180A Rear Panel**

**Sample Clock In** This SMB connector accepts an external signal that will replace the internal sample clock generator. This input accepts signals from 2 GHz to over 4 GHz, with an input power of 0dBm to 10dBm. The sample clock input is available for those applications requiring improved phase noise characteristics for the output signal. With a suitable source, the overall phase noise can be improved by a factor of up to 20dBc/Hz. The sample clock input is active only after selecting the external SCLK source option.

---



The internal sample clock generator is sensitive to noise that might be injected through the Sample Clock input. Any signal that is connected to this input may impair the operation of the internal clock. Therefore, connect a cable to the Sample Clock In connector only if you intend to use it as an external clock source. For system applications, where cables are always connected to the Sample Clock In connector, make sure that the external source signal is turned off at all times when the internal sample clock source is in use.

---

**Segment / Sequence Control In** This 9-pin connector accepts TTL signals. Pin 1 to 8 control bits, 0 to 7 and pin 9 accepts a valid signal. This connector is used for controlling segments or sequences dynamically, depending if the output generates arbitrary waveforms or sequences. A specific segment is selected by applying a binary code to the segment control input. The output is changed to the selected segment after a valid signal is asserted. The same works for sequences where a specific sequence is associated with a binary code and selected by asserting the valid signal.

Channels 1 and 2 have similar inputs and each channel can be controlled to have a unique set of waveform and sequences controlled from this connector.

---

**Marker 1 / 2 Out** There are two markers available for each output channel. These are marked Marker 1 and Marker 2. The markers are generated differentially through SMB connectors. One may control marker position, width delay and amplitude. For bench operation, the display provides access to programming one marker transition however only when used remotely. Programmers may set multiple markers and program different marker properties for each transition instance.

---

**Instrument Synchronization** The 9W4 combo D-sub connector accepts and arbitrates signals that are necessary to synchronize two model **81180A**'s. Four of its pins are coaxial and are used for high-frequency signals, and the other five pins are used for low-frequency communication. A special cable is required to connect between two instruments.



For information on the connecting cable, contact your nearest Agilent dealer.

---

<b>Event In</b>	<p>This BNC connector duplicates the operation of the front panel trigger input, except it is used for synchronizing <b>81180A</b> operation with external events. The effect of the event input is shown in various tables of this chapter. The most common is to cause a sequence step to advance to another step.</p> <p>The event input is level and edge sensitivity and can be programmed just as the trigger input for trigger level and trigger slope. The event input affects both channels simultaneously if they are programmed to sense transitions from this input.</p>
<b>Ref In</b>	<p>This BNC connector accepts signals within the range of 10 MHz to 100 MHz that reference the sample clock generator. This input is normally used for synchronizing system components to a single clock reference.</p> <p>The <b>81180A</b> has to be programmed to reference frequency value and placed in external reference mode before it will use this input as reference.</p>
<b>LAN</b>	<p>This RG45 connector accepts standard Ethernet cable. Correct setting of the IP address is required to avoid conflicts with other instruments or equipment on the network. Information on how to change IP address and load instrument drivers to the computer is provided in the Installation chapter of this manual.</p>
<b>USB</b>	<p>This connector accepts standard USB-2 cable. The connection to the host computer is automatic and does not require any address setting from within the <b>81180A</b>.</p>
<b>GPIB</b>	<p>This 24-pin connector accepts standard GPIB cable. The GPIB address is configured using the front panel Utility menu. The <b>81180A</b> conforms to the IEEE-488.2 standard. Programming protocol is SCPI version 1993.0. GPIB cables are available separately from your Agilent dealer.</p>
<b>AC Line In</b>	<p>This 3-prong AC LINE connector accepts AC line voltage. The <b>81180A</b> senses the line voltage and sets the appropriate range automatically. Therefore, the traditional line voltage selector is not available on the rear panel.</p> <p>To avoid potentially hazardous situations, always connect the center pin to mains ground using the line cord that is supplied with the instrument.</p>

---

## AC Fuse

The AC fuse protects the **81180A** from excessive current. Always replace the fuse with the exact type and rating as printed on the rear panel. The fuse value is T1.25AH/250V. If the fuse blows again after replacement, we strongly recommend that you refer your instrument immediately to the nearest Agilent service center.

---

## 1.3 Run Modes

### Introduction

The **81180A** can be programmed to operate in one of three basic run modes: Continuous, Triggered and Gated. There are features associated with each basic run modes, such as: arming the output for an event to enable generation, delayed trigger, smart trigger and more. The **81180A** can also be prepared to accept triggers from various sources, such as: front panel trigger input, rear panel event input, an internal trigger generator and more. On top, the generator can be programmed to respond differently to trigger in a way that each trigger can override preceding triggered cycles or launch a continuous trigger burst where the waveform stop triggers a new waveform start after a pre-programmed interval.

Summary of all run modes, trigger sources and trigger features is given below.

---

**Continuous Run Mode** Bench operation usually requires that a continuous waveform is available at the output terminals when the instrument is powered up and the output is turned on. On the other hand, for system applications that tolerate signals only at a specific time frame, the **81180A** can be armed from remote to generate waveforms only after it receives an enable command, and then aborted when the signal is no longer required. *Table 1-1* summarizes the conditions in which the **81180A** can operate when set to continuous run mode. Armed operation is described below.

---

**Arming the Generator in Continuous Run Mode** Arming the **81180A** is an operation that is normally carried out when the generator is operated from remote. For this reason, only a remote command can modify the arm option to Armed. When armed, the output can be enabled using valid events that are sensed in one of the front panel trigger input, the rear panel event input or a remote enable command. Once enabled, the waveform can be stopped by a remote abort signal only.

*Table 1-1* summarizes the various controls for each output function of which the **81180A** can be operated when set to continuous run mode. The various controls are explained below.

**Waveform** – basic output function that the **81180A** can generate. There are five output functions available: Standard, Arbitrary, Sequenced (including advance sequencing), Modulated and Pulse.

**Advance mode** – affects the generator in sequenced and advanced sequencing only.

**Arm Options** – bench operation normally defaults to self-armed where the output generates waveforms immediately after turning it on. Arming the **81180A** places the outputs in a wait-for-valid-enable signal before waveforms are generated through the output connectors.

**Idle Waveform** – defines the shape of the waveform when the generator is self-armed or when armed but has not been enabled yet.

**Enable Signal** – defines the source of the enable signal. The BUS option disables the event input and only a remote command will enable the output. Event defines the event input as the source for the enable signal. Only one source is active at a time.

**Abort Signal** – defines the source of the abort signal. In this case, only BUS will cause the signal to stop.

**Wave Loops** – attributed to the sequence modes only, it defines how many times a segment will loop in a specific sequence setting.

**Seq Loops** – attributed to the sequenced waveforms only, it defines how many times a sequence will loop in a specific advanced sequence setting.

**Jump Flag** – attributed to sequence functions only, it defines if a segment or sequence will advance to the next step or wait for an external event before the jump.

**Jump Signal** – defines the source of the event that will cause a segment to jump to the next step in a specific sequence setting.

**Table 1-1: Arming the 81180A in Continuous Run Mode**

Waveform	Advance Mode	Arm Options	Idle Waveform	Enable Signal	Abort Signal	Wave Loops	Seq Loops	Jump Flag	Jump Signal
Standard	-	Self Armed	Wave	- (*)	-	-	-	-	-
	-	Armed	DC	BUS   Event	BUS	-	-	-	-
Arbitrary	-	Self Armed	Wave	-	-	-	-	-	-
	-	Armed	DC	BUS   Event	BUS	-	-	-	-
Sequenced	Auto	Self Armed	Sequence	-	-	1-1M	-	Bit (0   1)	Event
	-	Armed	Wave	BUS   Event	BUS	1-1M	-	Bit (0   1)	Event
	Once	Armed	Wave	BUS   Event	BUS	1-1M	1-1M	Bit (0   1)	-
	Stepped	Armed	Wave	BUS   Event	BUS	-	-	-	Event
Advance Sequence	Auto	Self Armed	-	-	-	1-1M	-	Bit (0   1)	Event
	-	Armed	Sequence	BUS   Event	BUS	1-1M	-	Bit (0   1)	Event
	Once	Armed	Sequence	BUS   Event	BUS	1-1M	1-1M	Bit (0   1)	-
	Stepped	Armed	Sequence	BUS   Event	BUS	-	-	-	Event
Modulated	-	Self Armed	-	-	-	-	-	-	-
	-	Armed	Wave	BUS   Event	BUS	-	-	-	-
Pulse	-	Self Armed	-	-	-	-	-	-	-
	-	Armed	Wave	BUS   Event	BUS	-	-	-	-

(\*) defines not relevant for this mode

**Triggered Run Mode** In triggered mode, the **Model 81180A** circuits are always armed to generate one output waveform. The trigger circuit is sensitive to transitions at the trigger input. Select between positive, negative or either transitions to trigger the instrument. You may also program the trigger level to the desired threshold level. When triggered, the generator outputs one waveform cycle and remains idle at the last point of the waveform.

The **Model 81180A** can be triggered from a number of sources:

- 1) Rear panel connector, designated as TRIG IN,
- 2) Front panel button marked as MAN TRIG (second function to the Enter button), and
- 3) Bus commands that are applied to the instrument from any interface, LAN, USB or GPIB.

Descriptions of the various trigger source options are detailed in the following paragraphs.

The trigger signal, whether it comes from an external source or from an interface command, is routed through electrical circuits. These circuits cause a small delay known as system delay. System delay cannot be eliminated completely. System delay is a factor that must be considered when applying a trigger signal. It defines the time that will lapse from a valid trigger edge or software command to the instant that the output reacts.

*Table 1-2* summarizes the various controls for each output function of which the **81180A** can be operated, when set to triggered run mode. The various controls are explained below.

**Waveform** – basic output function that the **81180A** can generate. There are five output functions available: Standard, Arbitrary, Sequenced (including advance sequencing), Modulated and Pulse.

**Advance mode** – affects the generator in sequenced and advanced sequencing only.

**Arm Options** – bench operation normally defaults to self armed where the output generate waveforms immediately after turning it on. Arming the **81180A** places the outputs in a wait-for-valid-enable signal before waveforms are generated through the output connectors.

**Idle Waveform** – defines the shape of the waveform when the generator is self-armed or when armed but has not been enabled yet.

**Initiate Signal** – defines the source from where a trigger is expected to initiate a waveform cycle. F.P defines the front panel MAN button as a trigger source. The BUS option disables the trigger input and only a remote command will enable the output. Trigger defines the trigger input as the source for the trigger signal. Only one source is active at a time.

**Abort Signal** – defines the source of the abort signal. In this case, only BUS will cause the signal to stop.

**Wave Loops** – for standard and arbitrary waveforms, this field defines a loop counter (burst). For sequence modes only, it defines how many times a segment will loop in a specific sequence setting.

**Seq Loops** – attributed to the sequenced waveforms only, it defines how many times a sequence will loop in a specific advanced sequence setting.

**Jump Flag** – attributed to sequence functions only, it defines if a segment or sequence will advance to the next step or wait for an external event before the jump.

**Jump Signal** – defines the source of the event that will cause a segment to jump to the next step in a specific sequence setting.

**Smart Trig** – defines if smart trigger controls can be applied to the active trigger function

**Table 1-2: 81180A Triggered Run Mode Controls**

Waveform	Advance Mode	Arm Options	Idle Waveform	Initiate Signal	Abort Signal	Wave Loops	Seq Loops	Jump Flag	Jump Signal	Smart Trig
Standard	-	Self Armed	-(.)	-	-	-	-	-	-	-
		Armed	DC	F.P. BUS Trigger	BUS	1-1M	-	-	-	Yes
Arbitrary	-	Self Armed	-	-	-	-	-	-	-	-
		Armed	DC	F.P. BUS Trigger	BUS	1-1M	-	-	-	Yes
Sequenced	Auto	Self Armed	-	-	-	-	-	-	-	-
		Armed	DC	F.P. BUS Trigger	BUS	1-1M	-	Bit (0   1)	Event	Yes
	Once	Armed	DC	F.P. BUS Trigger	BUS	1-1M	1-1M	Bit (0   1)	Event	-
	Stepped	Armed	DC	F.P. BUS Trigger	BUS	-	-	-	Event	Yes
Advanced Sequence	Auto	Self Armed	-	-	-	-	-	-	-	-
		Armed	DC	F.P. BUS Trigger	BUS	1-1M	-	Bit (0   1)	Event	Yes
	Once	Armed	DC	F.P. BUS Trigger	BUS	1-1M	1-1M	Bit (0   1)	Event	-
	Stepped	Armed	DC	F.P. BUS Trigger	BUS	-	-	-	Event	Yes
Modulated	-	Self Armed	-	-	-	-	-	-	-	-
		Armed	DC	F.P. BUS Trigger	BUS	1-1M	-	-	-	Yes
Pulse	-	Self Armed	-	-	-	-	-	-	-	-
		Armed	DC	F.P. BUS Trigger	BUS	1-1M	-	-	-	Yes

(.) defines not relevant for this mode

**Trigger Run Mode Extensions**

Trigger operation is available to assure that waveforms start only when a valid trigger is sensed at the trigger input connector. So it is with most waveform generators. However, the **81180A** provides further refinement of this function in a way that the trigger circuit can receive triggers from multiple sources, arbitrate and delegate the signal to the main trigger circuit and also delay the start of the waveform by a pre-defined period. This is to make sure events are not wasted and waveforms re-played only when they are absolutely required in the system. The various trigger-run mode extensions are described below.

**Delayed Trigger**

The delayed trigger function is exactly the same as the trigger mode, except a programmable delay circuit inhibits the generation of the output waveform for a pre-determined interval following a valid trigger event. The programmed delay time defines the time that will lapse from a valid trigger (hardware or software) to output.

The delay is programmable in steps of sample clock period and is can be set from 0 to 8e6 sample clock periods. Delayed trigger can be used in conjunction with external trigger, front panel manual trigger, or remote trigger command. It has no effect on the internal trigger timer, nor does it affect the event input.

<b>Trigger Override</b>	<p>Normal trigger sequence requires that a waveform completes its cycle before the generator can be triggered to generate another waveform. Some applications, however, cannot wait for the end of the waveform, but must initiate another trigger cycle.</p> <p>The <b>81180A</b> features an override mode that ignores the output and upon trigger, initiates a fresh output waveform, whether the last one has been completed or not.</p> <p>Note that the trigger override mode operates on single segments only; it does not affect sequences and/or advanced sequence waveforms. Also note that the override trigger must precede the end of the signal by at least 64 sample clock periods.</p>
<b>Internal Timer</b>	<p>The internal timer generator operates as a free-running asynchronous trigger generator. It may be used for applications that require periodical and constant generation of output cycles, or to replace external trigger devices. The internal trigger generator is programmed in units of time through the range of 100 ns to 20 seconds. Note: in order to prevent errors, the period of the internal generator must be larger than the period of the output waveform.</p>
<b>Delay Timer</b>	<p>Contrary to the trigger override mode that was described before, certain applications cannot tolerate new cycles before the last one comes to a halt.</p> <p>The <b>81180A</b> features a special re-trigger mode that is very similar to the internal trigger generator where the output is self-triggered by an internal trigger generator, but the new waveform starts only after a programmed delay interval, and therefore assures that triggers are spaced equally and never override active sequences. The delay value is programmed in units ranging from 152 to 8e6 sample clock periods.</p>
<b>Counted Burst</b>	<p>Counted burst is an extension of the trigger run mode. It allows generation of a counted number of output cycles, which are triggered by single trigger event. The burst counter can be used in conjunction with all waveform functions that the <b>81180A</b> generates. The burst counter is programmed from 1 to 1,048,576.</p>
<b>Smart Trigger</b>	<p>Smart trigger is an additional extension of the trigger capability, where it narrows down to a specific pulse event. The trigger circuit can detect: a pulse having a pulse width larger than a programmed time value (&lt;time), a pulse having a pulse width smaller than a programmed time value (&gt;time), or a pulse having a pulse width between two limits (&lt;&gt;time).</p>

An additional feature of the smart trigger is the holdoff function where the output is held idle after the first trigger and starts a waveform cycle only with the first valid trigger after a holdoff interval has lapsed.

---

**Trigger Source** The Model **81180A** can be stimulated to produce waveform functions from a number of trigger sources. These are described in the following paragraphs. Summary of trigger source options and trigger features are listed in *Table 1-3 and Table 1-4*, identifying legal run modes, trigger sources and trigger features and listing possible setting conflicts.

---

**Trigger Input** When selecting the External trigger source, the front panel TRIG IN connector becomes active and every valid signal that is applied to this input is stimulating the **81180A** to generate a new waveform cycle. When the external trigger source is active, all other sources are disabled, except the MAN front panel button.

The characteristics of the trigger input are listed in Appendix A. The trigger input is sensitive to transitions and may be programmed to react on positive, negative or both positive and negative transitions. It can also be programmed to a specific trigger levels setting from -5 V to 5 V.

---

**Manual Button** Alternately, if an external signal is not available, the front panel MAN button may also be used to trigger the instrument. This button is active only when EXT trigger option is selected.

---

**Remote Command** When selecting Bus as a trigger source, the front panel TRIG IN connector and MAN button are disabled and only trigger commands from a remote interface are accepted by the instrument. In this case, the event input is also disabled. Make sure that the appropriate trigger source is selected if you mix remote and local operation.

---

**Event Input** The event input is a rear-panel connector that duplicates functionality of the front panel trigger input, but can be used for detecting events or advancing sequence steps. For most applications, this input should not be used as a second trigger input. One of the main applications for this input is to serve as an enable port for armed operation in continuous run mode.

Similar to the front panel trigger input, the event input is sensitive to transitions and may be programmed to react on positive or negative



transitions. It can also be programmed to a specific trigger levels setting from -5 V to 5 V.

### Internal Timer

The internal timer is normally used when an external source trigger is not available and an application requires triggers at constant intervals. The internal trigger generator can be programmed for start-to-start trigger intervals, using time units and for stop-to-start trigger intervals, using sample clock period units.

When one of the internal timers is activated, all external and remote triggers are blocked to prevent interference to the internal timer from external devices.

**Table 1-3: Run Modes and Trigger Source Options Summary**

Run Mode	Trigger Option	Status
Continuous (Armed)	External – TRIG IN External – EVENT IN Internal Front panel MAN button Remote command	Disabled Active Disabled Active Active
Triggered	External – TRIG IN External – EVENT IN Internal Front panel MAN button Remote command	Active Disabled Disabled Active Active
Gated	External – TRIG IN External – EVENT IN Internal Front panel MAN button Remote command	Active Disabled Disabled Active Disabled

**Table 1-4: Trigger Sources and Trigger Features Options Summary**

<b>Trigger Source</b>	<b>Trigger Feature</b>	<b>Status</b>
TRIG IN	Self armed / Armed Delayed trigger Burst counter Internal timer Internal delay (re-trigger) Normal / Override <>time pulse width detector Holdoff	Disabled Active Active Disabled Disabled Active Active Active
EVENT IN	Self armed / Armed Delayed trigger Burst counter Internal timer Internal delay (re-trigger) Normal / Override <>time pulse width detector Holdoff	Active Disabled Disabled Disabled Disabled Disabled Disabled Disabled
Internal	Self armed / Armed Delayed trigger Burst counter Internal timer Internal delay (re-trigger) Normal / Override <>time pulse width detector Holdoff	Disabled Disabled Active Active Active Disabled Disabled Disabled
Bus	Self armed / Armed Delayed trigger Burst counter Internal timer Internal delay (re-trigger) Normal / Override <>time pulse width detector Holdoff	Active Active Active Disabled Disabled Active Active Active
MAN	Self armed / Armed Delayed trigger Burst counter Internal timer Internal delay (re-trigger) Normal / Override <>time pulse width detector Holdoff	Active Active Active Disabled Disabled Active Disabled Disabled

## Gated Run Mode

In gated mode, the **81180A** generates output waveforms on a stable gate level between two gate transitions. The only input that can be used in conjunction with this run mode is the front-panel trigger input connector. Also, the front panel MAN button can be used for the same purpose manually, but all other trigger entries are blocked for this function. The gate opens on the first trigger transition and closes on the second transition. Gate level and transition slopes are programmable. Trigger delay and re-trigger do not apply to the gated run mode.

*Table 1-5* summarizes the various controls for each output function of which the **81180A** can be operated when set to gated run mode. The various controls are explained below.

**Table 1-5: 81180A Gated Run Mode Controls**

Waveform	Advance Mode	Arm Options	Idle Waveform	Initiate Signal	Abort Signal	Wave Loops	Seq Loops	Jump Flag	Jump Signal	Smart Trig
Standard	-	Self Armed	-(*)	-	-	-	-	-	-	-
		Armed	DC	F.P.   Trigger	BUS	-	-	-	-	Yes
Arbitrary	-	Self Armed	-	-	-	-	-	-	-	-
		Armed	DC	F.P.   Trigger	BUS	-	-	-	-	Yes
Sequenced	Auto	Self Armed	-	-	-	-	-	-	-	-
		Armed	DC	F.P.   Trigger	BUS	1-1M	-	Bit (0   1)	Event	Yes
	Once	Armed	-	-	-	-	-	-	-	-
	Stepped	Armed	-	-	-	-	-	-	-	Yes
Advanced Sequence	Auto	Self Armed	-	-	-	-	-	-	-	-
		Armed	DC	F.P.   Trigger	BUS	1-1M	1-1M	Bit (0   1)	Event	Yes
	Once	Armed	-	-	-	-	-	-	-	-
	Stepped	Armed	-	-	-	-	-	-	Event	Yes
Modulated	-	Self Armed	-	-	-	-	-	-	-	-
		Armed	DC	F.P.   Trigger	BUS	1-1M	-	-	-	Yes
Pulse	-	Self Armed	-	-	-	-	-	-	-	-
		Armed	DC	F.P.   Trigger	BUS	1-1M	-	-	-	Yes

(\*) defines not relevant for this mode

**Waveform** – basic output function that the **81180A** can generate. There are five output functions available: Standard, Arbitrary, Sequenced (including advance sequencing), Modulated and Pulse.

**Advance mode** – affects the generator in sequenced and advanced sequencing only.

**Arm Options** – bench operation normally defaults to self-armed when the output generates waveforms immediately after turning it on. Arming the

**81180A** places the outputs in a wait-for-valid-enable signal before waveforms are generated through the output connectors. Self-armed is not optional for gate operation.

**Idle Waveform** – defines the shape of the waveform when the generator is armed, but has not been enabled yet.

**Initiate Signal** – defines the source from where a gating signal is expected to initiate an output. F.P defines the front panel MAN button as a manual gating source.

**Abort Signal** – defines the source of the abort signal. In this case, only BUS will cause the signal to stop.

**Wave Loops** – for standard and arbitrary waveforms, this field defines a loop counter (burst). For sequence modes only, it defines how many times a segment will loop in a specific sequence setting.

**Seq Loops** – attributed to the sequenced waveforms only, it defines how many time a sequence will loop in a specific advanced sequence setting.

**Jump Flag** – attributed to sequence functions only, it defines if a segment or sequence will advance to the next step or wait for an external event before the jump.

**Jump Signal** – defines the source of the event that will cause a segment to jump to the next step in a specific sequence setting.

**Smart Trig** – defines if smart trigger controls can be applied to the active trigger function

---

## 1.4 Output Type

**Introduction** The Model 81180A can output various types of waveforms, including: Standard, Arbitrary, Sequenced, Modulated and Pulse. The various output types are described in the following paragraphs.

---

**Standard Waveforms** An array of built-in standard waveforms is available when the **81180A** is placed in its standard waveforms mode. The waveforms are calculated mathematically from known equations and converted to waveform coordinates that are then downloaded to the working memory. Unlike analog function generators that use electrical circuits to produce waveform shapes, the **81180A** must compute its waveform coordinates every time a new function is selected or every time that parameters of the function change.

The **81180A** can produce 11 standard waveforms: sine, triangle, square, ramp and pulse, sinc, gaussian and exponential pulses, DC and Pseudo-random noise. Some of the waveform parameters can be modified, such as: start phase for sine and triangle, duty cycle for square, rise and fall times for pulses, etc. The standard waveforms are the most commonly used wave shapes and therefore, were collected to a library of standard waveforms that can be used without the need to do off-product computation and use remote devices to download waveform coordinates.

The repetition rate of the standard waveforms is given in units of Hz. Since each channel has its own clock source, different waveforms, frequencies and run modes can be generated from its two outputs. On the other hand, when a common sample clock feed is selected, the two outputs must share the same run mode, but can still generate different waveforms and a unique set of parameters for each channel without interference between the channels.

When synchronization between channels is turned on, minimal skew of the waveform starting edges is maintained between the two channels.

*Figure 1-4* shows typical display for the standard waveforms function.

---

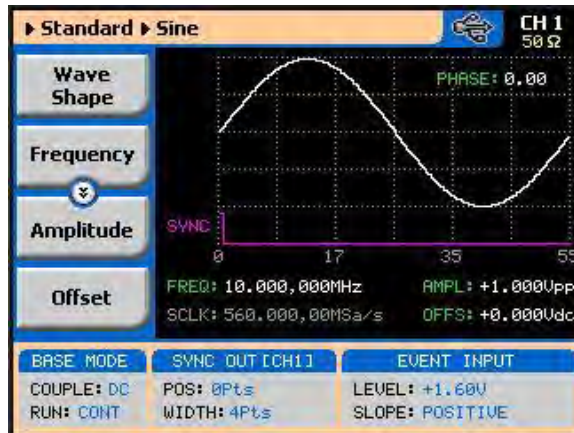

Figure 1-4: Typical 81180A Standard Waveforms Display

**Arbitrary Waveforms** One of the main functions of the **81180A** is generating real-life waveforms. These are normally not sine waves and squares, but user specific waveforms. Generating such waveforms requires external utilities such as MatLAB or even spreadsheets, but having the program alone is not enough for the **81180A**. Once the waveform is computed and defined, it must be converted to coordinates and then to a format, which the instrument can accept.

Arbitrary waveforms are stored as digital XY coordinates in a special memory, normally referred to as working memory. Each coordinate is referred to as waveform point, or waveform sample. The waveform is better defined if it has many waveform points. For example: with only 8 points, a sine waveform will hardly resemble the shape of a sine wave and will look more like an up and down staircase, but with 320 points, the same sine waveform will look almost perfect.

The final shape of the waveform is produced by a DAC (Digital to Analog Converter). The waveform samples are clocked to the DAC at a rate defined by the sample clock frequency. The output of the DAC converts the digital data to analog levels and passes on the signal to the output amplifier. The shape of the function is more or less the same as it comes out of the DAC, except it could be amplified or attenuated, depending on the required amplitude level.

The size of the working memory is limited to the way the hardware was designed. The **81180A** has 16 Meg points available as standard (64 Meg point optional) to build one or more waveforms. There is no need to use the entire memory for only one waveform, as the memory can be divided into smaller segments and loaded with different waveforms. The generator can be then programmed to output one segment at a time.

The **Model 81180A** has separate arbitrary waveform memories for each channel and each channel can be loaded with different waveforms. Channels are not limited by the number of segments and by the shape of the waveforms. *Figure 1-5* shows a typical display for the arbitrary waveform function.

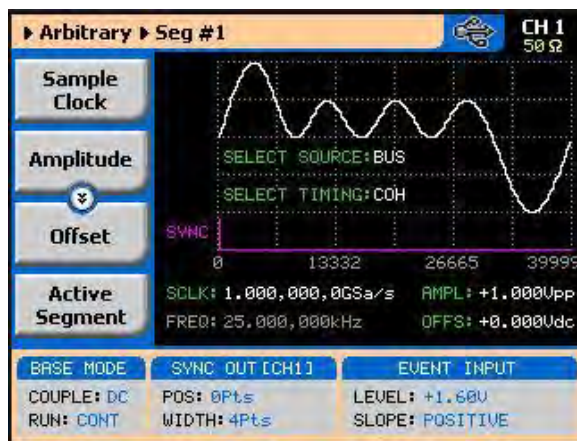

**Figure 1-5: Typical 81180A Arbitrary Waveforms Display**

## Sequenced Waveforms

The sequence generator is a very powerful tool that lets you link and loop segments in any way you desire. The **Model 81180A** has two separate sequence generators – one for each channel. Each sequence generator is dedicated to its own channel. *Figure 1-6* shows a typical display for the sequenced waveforms function.

The sequence circuit is useful for generating long waveforms with repeated sections. The repeated waveform has to be programmed once and the repeater will loop on this segment as many times as selected. When in sequenced mode, there is no time gap between linked or looped segments. Sequence tables must be loaded to the generator before sequenced waveforms can be generated. The data for the sequence table is first prepared on an external platform and then downloaded to the generator using external utilities such as MatLab.

As a simple example of a sequenced waveform, look at *Figure 1-6* through *Figure 1-9*. The waveforms shown in these figures were placed in memory segments 1, 2 and 3, respectively. The sequence generator takes these three waveforms links and loops them in a predefined order to generate the waveform shown in *Figure 1-10*.

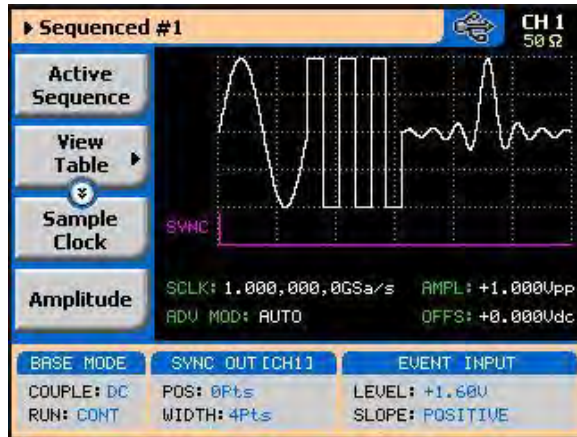

Figure 1-6: Typical 81180 Sequenced Waveforms Display

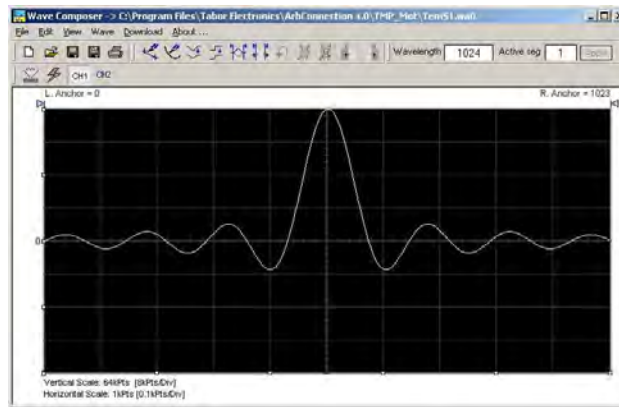

Figure 1-7: Segment 1 Waveform – Sinc

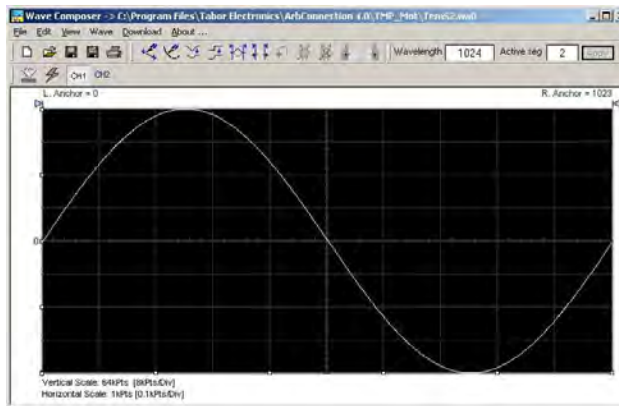
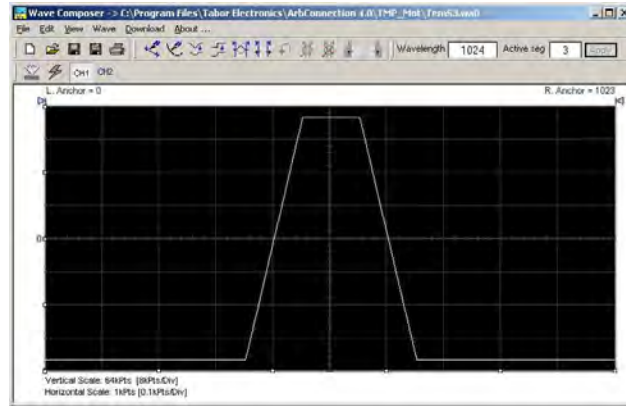

Figure 1-8: Segment 2 Waveform - Sine





**Figure 1-9: Segment 3 Waveform – Pulse**

The following sequence was made of segment 2 repeated twice, segment 1 repeated four times, and segment 3 repeated two times.

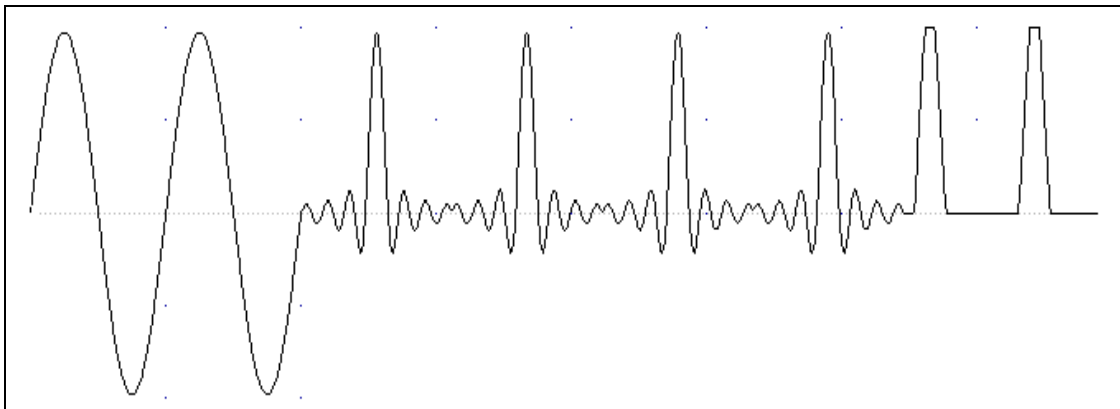

**Figure 1-10: Sequenced Waveform**

The above figure shows a typical front panel entry for a simple sequence table.



Figure 1-11: Typical Display of a Sequence Table

**Advanced Sequencing** Advanced sequencing is an extension of the sequencer functionality. It describes a function that is capable of sequencing complete sequences and therefore creating very complex scenarios that otherwise would have required extremely large memory banks. For example, a sequence of initiating communication between ground station and airborne vehicle requires repetition of a certain sequence of transmissions, and then the message itself is embedded in a separate transmission sequence.

Such a complex communication scheme is easily achieved with the advanced sequencing technique that has been employed by the **81180A**. Information how to build sequences and generate advanced sequences is given in Chapter 3.

**Sequence Advance Mode** As shown above, sequences are built as a simple table, defining link, segment, loops and advance bits. When placed in sequenced mode, the output is changed from step-to-step in ascending order. The term Sequence Advance Modes defines what is causing the instrument to step through the table rows. There are three basic advance modes that can be selected for the sequence mode: Auto, Once and Stepped.

The various advance mode options are summarized separately for each run mode option in *Table 1-1*, *Table 1-2* and *Table 1-5*. These modes are explained in the following paragraphs.

**Auto Advance Mode** Auto advance sequence is the mode used when the sequence is expected to run continuously from the first step in the sequence table to the last, and then resume the same sequence automatically from its first step. There are no interruptions between steps and no interruptions between the last and the first step of the sequence.

When auto mode is selected, the **81180A** can also be armed to start only when an enable signal is established.

---

### **Once Advance Mode**

The Once sequence advance is the mode used when the sequence is expected to advance on trigger events only. The trigger source is selectable from an external, front panel MAN button, or a remote command. The sequence will run upon valid initiation signal and will stop and wait for another trigger to commence with another cycle. Jump bits can be placed in various sequence steps to allow dwelling on a specific waveform segment and the next step will start only after a valid jump signal is asserted.

The Once advance mode has a repeat counter for applications requiring a counted number of sequences. In this case, the counter can be programmed to generate 1 to 1,048,576 sequences automatically and then wait for a fresh trigger event to repeat this scenario.

---

### **Stepped Advance mode**

Stepped advance sequence is the mode used when the sequence is expected to advance on specific events only. This advance mode operates in conjunction with all Run Modes, as listed in *Table 1-1*, *Table 1-2* and *Table 1-5*. When stepped advance mode is selected, the generator steps through sequence steps on valid events only. After the last step in the sequence table, the generator advances to the first row and repeats the sequence automatically.

---

### **Sequence Advance Source**

As explained above, the Once and Stepped sequence advance modes require a stimulus signal to advance to the next step in the sequence table. There are a number of inputs where the **81180A** can be programmed to wait for an event that implies go-to-next-step instruction, including: Front panel MAN button, Front panel TRIG IN connector, Rear panel EVENT IN connector, or a software command that is asserted to the generator through one of its interface options. *Table 1-1*, *Table 1-2* and *Table 1-5* list all advance source options for each of the basic run modes: Continuous, Triggered and Gated.

---

### **Modulated Waveforms**

Modulated waveforms are computed mathematically and downloaded to the arbitrary waveform memory and generated at the output connector as an arbitrary waveform. The **81180** has a library of three most common and popular modulation schemes: FM, AM and Sweep. Other modulation schemes such as

I&Q, PSK and QAM can be designed on an external utility and downloaded to the **81180A** as arbitrary waveforms. The accuracy, stability and noise-free properties of the dual-channel **81180A** generator will replay these waveforms with very little distortion or phase noise modulation.

*Figure 1-12* shows a typical display for the modulated waveform function. General description of all modulation functions is given in the following.

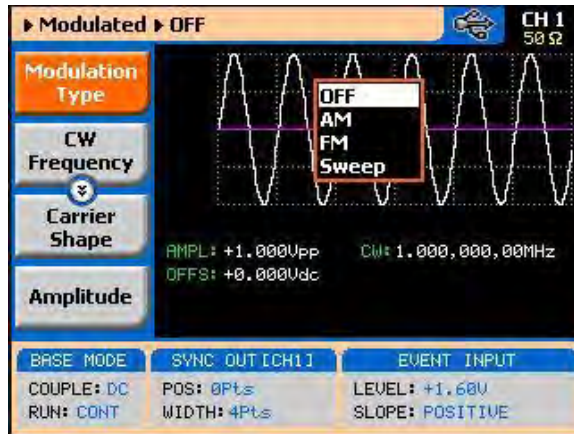

**Figure 1-12: Typical 81180A Modulated Waveform Display**

### **Modulation Off**

In modulation OFF, the output generates continuous Carrier Waveform frequency. The carrier waveform is sinewave and its frequency can be programmed using the CW Frequency menu. The value programmed for the CW Frequency parameter is used for all other modulation functions.

---

### **AM**

The AM function enables amplitude modulation of a carrier waveform (CW). The carrier waveform is sinewave and is modulated by an internal waveform, normally referred to as an envelope waveform. The envelope waveform can be selected from sine, triangle, square or ramp shapes.

---

### **FM**

The FM function allows frequency modulation of a carrier waveform (CW). The carrier waveform is sinewave and is modulated by an internal waveform, normally referred to as modulating waveform. The modulating waveform can be selected from sine, triangle or square waveforms.

---

**Sweep** Sweep modulation allows carrier waveform (CW) to sweep from one frequency, defined by the sweep start parameter to another frequency, defined by the sweep stop parameter. Note that CW is sinewave only. The start and stop frequencies can be programmed throughout the entire frequency range of the instrument.

**Pulse Waveforms** The pulse generator function transforms the instrument into a pulse generator with the capability to generate pulses, exactly as they would be generated by a stand-alone pulse generator instrument. However, one should not forget that the **81180A** is a digital instrument and therefore the pulses are computed and placed in the waveform memory and then replayed at the output as arbitrary waveforms. When using this pulse function, one could program all pulse parameters in units of time (seconds) just as it would have been done on an analog instrument, but as a digital instrument, some of the parameters may take time to be computed and placed at the output connector.

All pulse parameters are programmable, including: period, pulse width, rise and fall times, delay, polarity and more. As a dual channel instrument, you may program different pulse settings for each channel, operate each channel separately or synchronize the two channels so that both outputs transition at the same time. Operating instructions for the pulse generator are given in Chapter 3.

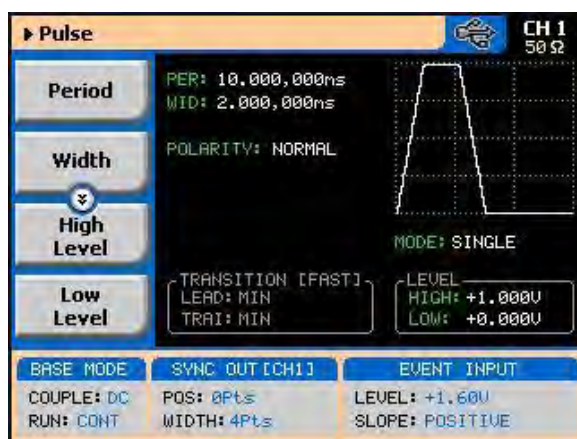

Figure 1-13: Typical 81180A Pulse Generator Display

### Multi-Instrument Synchronization

Applications that require more than two channels present a problem, because most of the instruments that are available on the market normally have at a maximum two output channels. With the built-in synchronization feature and with a simple synchronization cable and LAN connections, you can

synchronize two **81180A** units to create a fully synchronized four-channel system, without the slightest degradation of performance of individual instruments and with complete control over the start phase of each of the synchronized channels. Information on how to synchronize **81180A** instruments is given in Chapter 3.

---

## 1.5 Output State

### Introduction

The main outputs can be turned on or off. However, the internal circuit is left connected to the output connector and so the impedance on this output remains low. If you do not intend to use a specific output, always remove the cables from this connector to prevent accidental application of external signals to the output circuit. For application safety reason, when the instrument is powered up, the outputs are always off. For the same reason, when front panel settings are recalled from a stored setup, the outputs are always off.

---

## 1.6 Programming the Model 81180A

### Introduction

Some of the **81180A** functionality can be operated from the front panel and is mostly done with built-in libraries of waveforms. However, most applications require that waveforms are downloaded from a host computer and therefore, remote operation is essential for this class of instrument. Programming the **81180A** requires that the appropriate software utilities be installed in the computer and the rest is a matter of practice and knowledge of the language in use. There are other system considerations, such as address selection, that have to be settled before programming the instrument. These topics are discussed in later chapters.

Low level programming of the **Model 81180A** is done using SCPI commands. Programming aspects are covered in Chapter 4. High- level drivers like IVI drivers are beyond the scope of this manual. Contact your Agilent representative for more information about high level drivers for the **Model 81180A**.

---

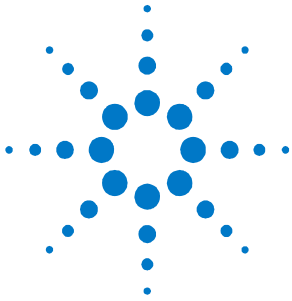

## 2 Configuring the Instrument

### 2.1 Installation Overview

#### Introduction

This chapter contains information and instructions necessary to prepare the Model 81180A for operation. Details are provided for initial inspection, grounding safety requirements, repackaging instructions for storage or shipment, installation information and Ethernet address configuration.

---

### 2.2 Unpacking and Initial Inspection

#### Introduction

Unpacking and handling of the generator requires standard precautions and procedures applicable to handling of all sensitive electronic equipment. The contents of all shipping containers should be gone through to be sure that all accessories are included and checked against the packing slip to determine that the shipment is complete.

---

### 2.3 Safety Precautions



This product is intended for use by qualified persons who are familiar with the safety precautions required to avoid possible injury. Read the operating information carefully before using the product

---



For maximum safety, do not touch the product, test cables, or any other instrument parts while power is applied to the circuit under test. ALWAYS remove power from the entire test system before connecting cables or jumpers, installing or removing cards from the computer, or making internal changes such as changing the module address.

Do not touch any object that could provide a current path to the common side of the circuit under test or power line (earth) ground. Always handle the instrument with dry hands.



Always keep the lid closed when power is applied to the device under test conditions. Carefully read the Safety Precautions instructions that are supplied with your test fixtures.

Any adjustment, maintenance and repair of an opened, powered-on instrument must be performed by authorized service personnel.

---

## 2.4 Performance Check

### Introduction

The instrument has been inspected for mechanical and electrical performance before shipment from the factory. It is free of physical defects and in perfect electrical order. Check the instrument for possible damage in transit and perform the electrical procedures outlined in the section entitled Unpacking and Initial Inspection.

---

## 2.5 Power Requirements

### Introduction

The waveform generator can operate from any single-phase AC power source supplying 100 – 240 V in the frequency range from 50 – 60 Hz. The maximum power consumption is 150 VA. The power supply automatically adapts to the applied AC power (Auto Selection) and monitors the AC power range. The mains supply voltage fluctuation shall not exceed 10% of the specified supply voltage.

The 81180A must be operated from a power source with neutral or near ground (earth potential). The instrument is not intended for operation from two phases of a multi-phase ac system or across the legs of a single-phase, three-wire ac power system. Crest factor (ratio of peak voltage to rms.) should be typically within the range of 1.3 to 1.6 at 10% of the nominal rms. mains voltage.

---



## 2.6 Grounding Requirements

**Introduction** To ensure the safety of operating personnel, the U.S. O.S.H.A. (Occupational Safety and Health) requirement and good engineering practice mandate that the instrument panel and enclosure be “earth” grounded. Although BNC housings are isolated from the front panel, the metal part is connected to earth ground.

---



Do not attempt to float the output from ground, as it may damage the Model 81180A and your equipment.

---

## 2.7 Long Term Storage or Repackaging for Shipment

**Introduction** If the instrument is to be stored for a long period of time or shipped to a service center, proceed as directed below. If repacking procedures are not clear to you or, if you have questions, contact your nearest Agilent Representative, or the Agilent Customer Service Department.

Repack the instrument using the wrappings, packing material and accessories originally shipped with the unit. If the original container is not available, purchase similar replacement materials.

Be sure the carton is well-sealed with strong tape or metal straps.

Mark the carton with the model and serial number. If it is to be shipped, show sending and return addresses on two sides of the box.

---



If the instrument is to be shipped to Agilent for calibration or repair, contact your local Agilent sales office or local Agilent service center.

---

## 2.8 Preparation for Use

### Introduction

Preparation for use includes removing the instrument from the container box, installing the software and connecting the cables to its input and output connectors.

---

## 2.9 Installation

### Preparation for Use

If the intention is to mount the instrument in a rack, it must be installed in a way that clears air passage to its cooling fans. For inspection and normal bench operation, place the instrument on the bench so it is clear of any obstructions to the rear fan, to ensure proper airflow.

---



Using the 81180A without proper airflow will result in damage to the instrument.

---

## 2.10 Installing IVI Drivers

### Introduction

The IVI driver is a useful utility that provides standard communication and commands structure to control the 81180A from remote. Programming examples are also available to expedite your software development. The IVI driver comes free with the 81180A. However, you'll need the IVI engine and visa32.dll run time utilities to be able to use the IVI driver. The latest IVI driver can be downloaded for free from Agilent's web site – [www.agilent.com/find/81180](http://www.agilent.com/find/81180).

---

## 2.11 Controlling the Instrument from Remote

### Introduction

In general, the 81180A can be controlled from remote, using one of the following interfaces: USB, Ethernet or GPIB. Remote interface cables are not supplied with the instrument, so if you plan on using one of the remote programming options, make sure you have a suitable cable to connect to your host computer. The following paragraphs describe how to connect and configure the 81180A to operate from remote. The description is given for computers fitted with Windows XP, but installing software on other Windows versions is quite similar.

---

## 2.12 Connecting to a Remote Interface

### Introduction

You can connect your Agilent 81180A to GPIB, USB, or LAN adapters, depending on the application and requirements from your system. Installing interface adapters on your computer are not described in this manual, since the installation procedures for these adapters change frequently. Follow the instructions supplied with your particular adapter. Before proceeding with the remote interface installation, install an adapter card and follow the instructions as follows:

---

### GPIB Connection

Direct connection between a host computer and a single device with GPIB is not recommended, since GPIB adapters are usually expensive and not really required for direct connection. Use a GPIB connection in cases where download speed is critical to the system or when you already have a GPIB system in place and you are adding the 81180A as a GPIB device. The GPIB port is connected with a special 24-wire cable. Refer interconnection issues to your GPIB supplier. After you connect the 81180A to the GPIB port, proceed to the GPIB Configuration section in this chapter for instructions how to select a GPIB address.

---

### USB Connection

Direct connection between a single-host computer and a single device with USB is recommended, as this does not require any specific considerations or device configurations. Just connect your Agilent 81180A to your PC using a standard USB cable and the interface will self-configure. After you connect the 81180A to the USB port, proceed to the USB Configuration section in this chapter for instructions how to install the USB driver.

---

**LAN Connection**

Direct connection between a single-host computer and a single device with 10/100/1000 Base-T is possible, but you must use a special cable that has its transmit and receive lines crossed. If your site is already wired, connect the 81180A via twisted-pair Ethernet cable. Be sure to use twisted-pair wires designed for 10/100/1000 Base-T network use (phone cables will not work). Refer interconnection issues to your network administrator. After you connect the 81180A to the LAN port, proceed to the LAN Configuration section in this chapter for instructions how to set up LAN parameters

---

## 2.13 Selecting a Remote Interface

**Introduction**

The 81180A is supplied by the factory with the active remote interface set to USB. If you intend to use USB connection, all you need to do is connect your USB cable and proceed with the USB Configuration instructions as given in this chapter to install the USB driver and configure the USB port (first connection only). If you already used your instrument in various platforms and want to re-select your interface, you need to access the Select Interface screen as shown in *Figure 2-1*. To access this screen, press the Utility key in the Control group, then select the Remote Interface soft key and then the Select Interface soft key button.

Use the cursor keys left and right to point to the required interface option, then press Enter. The new interface will initialize and the icon at the top will be updated and will flag the active interface option.

The interface icon is always displayed at the top of the screen, so if you are not sure which of the interfaces is selected, compare the following icons to what you have on the screen:



Designates GPIB interface is selected and active. GPIB configuration is required to communicate with your PC.



Designates USB interface is selected and active. First connection requires USB configuration and software driver installation to communicate with your PC.



Designates LAN interface is selected and active. LAN configuration is required to communicate with your PC.

---

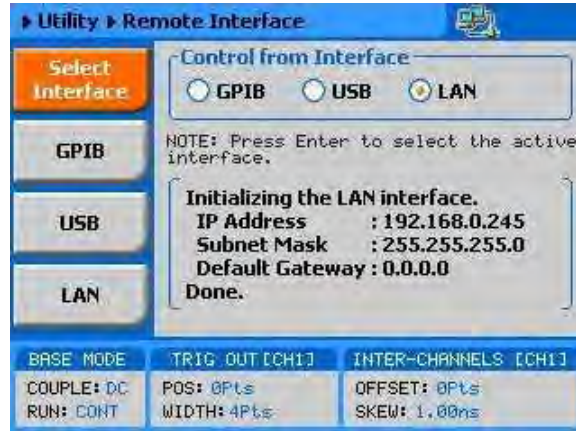

Figure 2-1: Selecting a Remote Interface

## 2.13.1 GPIB Configuration

### Introduction

GPIB configuration requires an address setting only. If you intend to use more than one instrument on the bus, you have to make sure each device has a unique address setting. GPIB address is programmed from the front panel Utility menu as shown in *Figure 2-2*. To access this screen, press the Utility control button, then press the Remote Interface soft key button and then select the GPIB soft key button. The display will be updated with the current GPIB address. The default address is 4. To modify the address, press the Enter key and use the dial or keypad to select the new address. Press Enter for the 81180A to accept the new address setting.



Configuring your GPIB address setting does not automatically select the GPIB as your active remote interface. Setting a remote interface is done from the Select interface menu. Information how to select and Interface is given earlier in this chapter..

---



Figure 2-2: GPIB Configuration Screen

## 2.13.2 USB Configuration

### Introduction

Make sure you select USB as the Remote Interface from the front panel of the Agilent 81180A. Otherwise, USB requires no further front panel configuration parameters. Following the simple installation steps as shown later in this chapter, just connect your Agilent 81180A to your PC using a standard USB cable and the interface will self-configure. The first time you connect the generator to your PC, the new hardware will be detected and the message, as shown in *Figure 2-3*, will appear. After a few seconds, the message, as shown in *Figure 2-4*, will appear.



Figure 2-3: USB Device Detected, 1<sup>st</sup> Message



Figure 2-4: USB Device Detected, 2<sup>nd</sup> Message



**Figure 2-5: Found New Hardware Wizard**

Immediately thereafter, the Found New Hardware Wizard will open, as shown in *Figure 2-5*. Select the Install the software automatically (Recommended) option and click on next. Note that Agilent I/O library 15.0 or later must be installed on your computer for the driver to install automatically. When the new driver has been detected and installed, expect to see the following dialog box on the computer screen:



**Figure 2-6: New Hardware Found and Software Installed**

Figure 2-6 shows that the Agilent 81180A USB Waveform Generator has been found and the software driver installed. To make sure your USB port and the Agilent 81180A configured correctly, compare your Device Manager to the example in Figure 2-7.

---



**Figure 2-7: Model 81180A Configured for USB Operation**



Configuring your USB setting does not automatically select the USB as your active remote interface. Setting a remote interface is done from the Select Interface menu. Information how to select and Interface is given earlier in this chapter.

---



### 2.13.3 LAN Configuration

There are several parameters that you may have to set, in order to establish network communications using the LAN interface. Primarily, you'll need to establish an IP address. You may need to contact your network administrator for help in establishing communications with the LAN interface. To change LAN configuration, you need to access the LAN screen, as shown in *Figure 2-8*.

To access this screen, press the Utility control button, then press the Remote Interface soft key button and select the LAN soft key button. The display will be updated with the current LAN settings.

Note: there are some parameters that are shown on the display that cannot be accessed or modified: Physical Address and Host Name. These parameters are set in the factory and are unique for this specific product. The only parameters that can be modified are the IP Address, the Subnet mask and the Default gateway. Correct setting of these parameters is essential for correct interfacing with the LAN network. Description of the LAN settings and information on how to change them is given in the following.



Configuring your LAN setting does not automatically update LAN parameters or select the LAN as your active remote interface. Setting a remote interface is done from the Select interface menu. LAN parameters will be updated only after re-selecting the LAN interface from the Select Interface menu. Information how to select and Interface is given earlier in the chapter.

---



**Figure 2-8: LAN Configuration Screen**

There are three LAN parameters in this screen that can be modified and adjusted specifically to match your network setting, as described below. Consult your network administrator for the setting that will best suit your application.

**IP address** - The unique, computer-readable address of a device on your network. An IP address typically is represented as four decimal numbers separated by periods (for example, 192.160.0.233). Refer to the next section: Choosing a Static IP Address.

**Subnet mask** - A code that helps the network device determine whether another device is on the same network or a different network.

**Gateway IP** - The IP address of a device that acts as a gateway, which is a connection between two networks. If your network does not have a gateway, set this parameter to 0.0.0.0.

## Choosing a Static IP Address

### For a Network Administered by a Network Administrator

If you are adding the Ethernet device to an existing Ethernet network, you must choose IP addresses carefully. Contact your network administrator to obtain an appropriate static IP address for your Ethernet device. Also have the network administrator assign the proper subnet mask and gateway IP.

### For a Network without a Network Administrator

If you are assembling your own small Ethernet network, you can choose your own IP addresses. The format of the IP addresses is determined by the subnet mask. You should use the same subnet mask as the computer you are using with your Ethernet device. If your subnet mask is 255.255.255.0, the first three numbers in every IP address on the network must be the same. If your subnet mask is 255.255.0.0, only the first two numbers in the IP addresses on the network must match.

For either subnet mask, numbers between 1 and 254 are valid choices for the last number of the IP address. Numbers between 0 and 255 are valid for the third number of the IP address, but this number must be the same as other devices on your network if your subnet mask is 255.255.255.0.

The following table shows examples of valid and invalid IP addresses for a network using subnet mask 255.255.255.0. All valid IP addresses contain the same first three numbers. The IP addresses in this table are for example purposes only. If you are setting up your own network, you probably do not have a gateway, so you should set these values to 0.0.0.0.

**Table 2-1: Valid and Invalid IP Addresses for Subnet Mask 255.255.255.0**

IP Address	Comment
123.234.45.211	Valid.
123.234.45.213	Valid. The first three numbers match the previous IP address. The fourth number must be a unique number in the range of 1 to 254.
123.202.45.214	Invalid. Second number does not match the previous IP addresses. The first three numbers must match on all IP addresses with subnet mask 255.255.255.0.
123.234.45.0	Invalid. The first three numbers are valid but the fourth number cannot be 0.
123.234.45.255	Invalid. The first three numbers are valid but the fourth number cannot be 255.



To find out the network settings for your computer, perform the following steps:

For Windows 98/Me/2000/XP

- 1 Open a DOS prompt.
2. Type IPCONFIG.
3. Press <Enter>.

If you need more information, you can run ipconfig with the /all option by typing IPCONFIG /all at the DOS prompt. This shows you all of the settings for the computer. Make sure you use the settings for the LAN adapter you are using to communicate with the LAN device.

---

## 2.14 Master Slave Operation

### Introduction

For applications that require more than 2 channels the built in synchronization feature allows for synchronizing two 81180A to create a fully synchronized four channel system. The procedure is described in the following paragraphs.

---

### 2.14.1 Connecting the Instruments

Two instruments can be synchronized only when cross-connected with a designated synchronization cable. To connect the cable, turn the power off on both instruments. Locate the rear-panel Master/Slave connector and attach each side of the cable to these connectors. Note that the connectors do not lock into position without screwing in the bolts on each side. Use flat tip screwdriver to latch the cables into their receptacle housing and make sure the connectors are straight and firmly locked into place. After you connect the cable you can power the instruments on again.

---

## 2.14.2 Resetting the Two Instruments

Once the two instruments have been connected using the synchronization cable the next step is to perform a factory reset on both units. Perform the following steps in both units:

1. Press the Utility Button
  2. Press the Factory Reset soft key button
  3. Use the left key to chose yes
  4. Press the enter button
- 

## 2.14.3 Selecting a Master

After the two instruments have been set to their factory default setting, the next step is to select one instrument as Master and the other as slave.

Perform the following steps:

1. On the designated slave unit, press the output button
  2. Press the X-Instr. soft key button
  3. Use the dial or the up/down keys to scroll to the Role option
  4. Press the Enter button
  5. Change the field to "Slave"
  6. Press the Enter button
  7. Turn on the channel outputs
  8. On the designated master unit, press the output button
  9. Press the X-Instr. soft key button
  10. Use the dial or the up/down keys to scroll to the State option
  11. Press Enter, change the field to "ON" and press Enter again
  12. Turn on the channel outputs
-

## 2.14.4 Operating Synchronized Instruments

When operating two synchronized instruments, there are some important limitations to be familiar with in order to achieve optimal performance.

1. Connecting the synchronization cable is pre-requisite however, additional steps must be performed to set one unit in master mode and select the other as slave.
2. The synchronization must be activated from the Master unit.
3. Sample Clock and output frequency must be identical in both units prior to activating the synchronization, and can only be controlled from the master unit once synchronization has been activated.
4. Both master and slave units must be placed in the same run mode to operate synchronously. For example, both units in trigger mode will synchronize however, one set to continuous and the other to trigger will not synchronize.
5. Both master and slave units must be placed in the same waveform mode to operate synchronously. For example, both units in sequence mode will synchronize however, one set to Arbitrary and the other to sequence will not synchronize.
6. In Sequence mode both Master and Slave units must have a sequence table with the same number of steps.
7. Each instrument can have a unique set of waveforms, active segment, sequence, amplitude, offset parameters and markers.
8. Trigger signal is applied to the master input and is common to both master and slave units.
9. The waveform can be delayed from the master output by a predefined number of sample clocks or by a set amount of time. Press the output button and then press the X.-Instr. softkey button. There are two fields, Offset and Skew. The offset field defines the number of sample clock cycles, or waveform points that the instrument will hold off before it will start generating the output waveform. The resolution is eight waveform cycle and the time is defined as eight clock cycle, which is set on the master unit. The offset is used for coarse tuning. The Skew defines fine offset between the instruments and is set in unit of time. The skew can be varied from -5ns to +5ns at a 10ps resolution and is used for fine tuning.

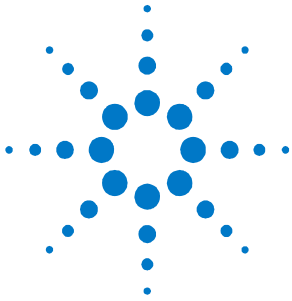

## 3 Features and Functions

### 3.1 Overview

This chapter contains information about how to operate the Agilent 81180A. Operation is divided into two general categories: basic bench operation, and remote operation (GPIB, USB and ENET). Basic bench operation, which is covered in this section, describes how to operate the arbitrary waveform generator using front panel sequences.

The following paragraphs describe the various modes of operation and give examples of how to program the Model 81180A. The manual is organized by instrument function, and instructions are given in each paragraph on how to use this function from the front panel.

---

### 3.2 Inter-Channel Dependency

The 81180A has two completely independent output channels. Each channel can be programmed to output a unique set of functions and parameters, which can be generated using separate run modes. As each channel is completely separate, there is no influence from one channel on its adjacent channel. There are a few controls that are shared by the two channels including: trigger and event inputs, sync output and remote interface connections.

On the other hand, there are many applications that require two (or more) channels. These are normally expected to share output frequency, sample clock and retain a controllable phase dependency. In this case, the 81180A can be placed in a common sample clock feed mode and transform its operation to a dual channel generator where run mode and output function are shared, but each channel remains independent to generate different waveforms and amplitudes.

---

### 3.3 Output Termination

During use, output connectors must be properly terminated to minimize signal reflection or power loss due to impedance mismatch. Proper termination is also required for accurate amplitude levels at the output connectors. Use 50 $\Omega$  cables and terminate the main and SYNC cables with terminating resistors. Always place the 50  $\Omega$  termination at the far end of the cables.

The 81180A has two output connectors for each channel, marked “Normal” and “Inverted”. If single-ended output is required, the other output must be terminated with a 50  $\Omega$  plug termination, right at the output connector. The DC and direct DAC outputs are generated differentially, but the AC output path is available through the Normal output only as a single-ended signal and therefore, termination on the other output is not a requirement.

Note that the display reading of the amplitude level is calibrated to show the actual level on the load, when the load impedance is roughly 50  $\Omega$ . In cases where the load has different impedance, the display will indicate a reading that does not match the actual amplitude level on the load.

---

### 3.4 Input / Output Protection

#### Input / Output Protection

The Model 81180A provides protection for the internal circuitry that is connected to input and output connectors. Refer to the specifications to determine the level of protection associated with each input or output connector.

---



The outputs can only be connected to resistive loads. Connecting the 81180A to inductive or capacitive loads may damage the output and void the warranty on the instrument.

---

### 3.5 Power On/Reset Defaults

#### Power On/Reset Defaults

The 81180A utilizes non-volatile memory backup that automatically stores the last setup before the generator has been turned off. Every time you turn on the instrument, the non-volatile memory updates the front panel setting with modes, parameters and waveforms from its last setting with only one exception, for safety reasons, the outputs remain off even if they were turned on before powering down the 81180A.



After power on, the instrument displays information messages and updates the display with the last setup information. The 81180A can always be reset to its default values. Information on how to restore default parameters is given below.

If you are not yet fully familiar with front panel operation of the 81180A, you may find yourself locked into a "dead-end" situation where nothing operates the way it should. The fastest way to restore the generator to a known state is by resetting the instrument to factory defaults.

As seen below, you can reset parameters to factory defaults as follows:

Press the Utilities control key

Press the Factory Rests soft key

Select Yes or No in the pop-up dialog box

Table 3-1 summarizes factory defaults for the most common parameters. A complete list of all parameters and their defaults, as well as their maximum and minimum values is given in the Programming Reference chapter.

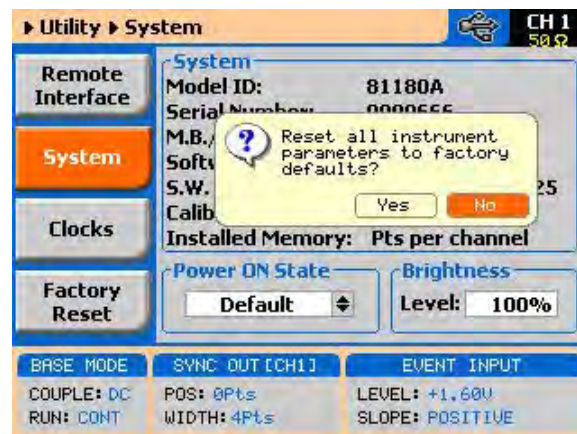

Figure 3-1: Reset 81180A to Factory Defaults

**Table 3-1: Default Conditions after Reset**

Function / Parameter	Default
Outputs State	Off
Output Couple Path	DC
SYNC State	Off
Operating Mode	Continuous
Active Channel	1
Marker Output State	Off
Output Function	Standard
Output Function Shape	Sine
Standard Wave Frequency	10 MHz
User Wave Sample Clock	1 GSa/s
Sample Clock Feed	Separate
Sample Clock Source & Reference	Internal
Amplitude	0.5 V
Trigger Slope:	Positive
Trigger Level:	1.6 V
Trigger Source:	External

### 3.6 Controlling the 81180A

#### Controlling the 81180A

Controlling 81180A function, modes and parameters is simply a matter of pressing once or twice on the appropriate button as described in the following paragraphs. Refer to *Figure 3-2* throughout this description.

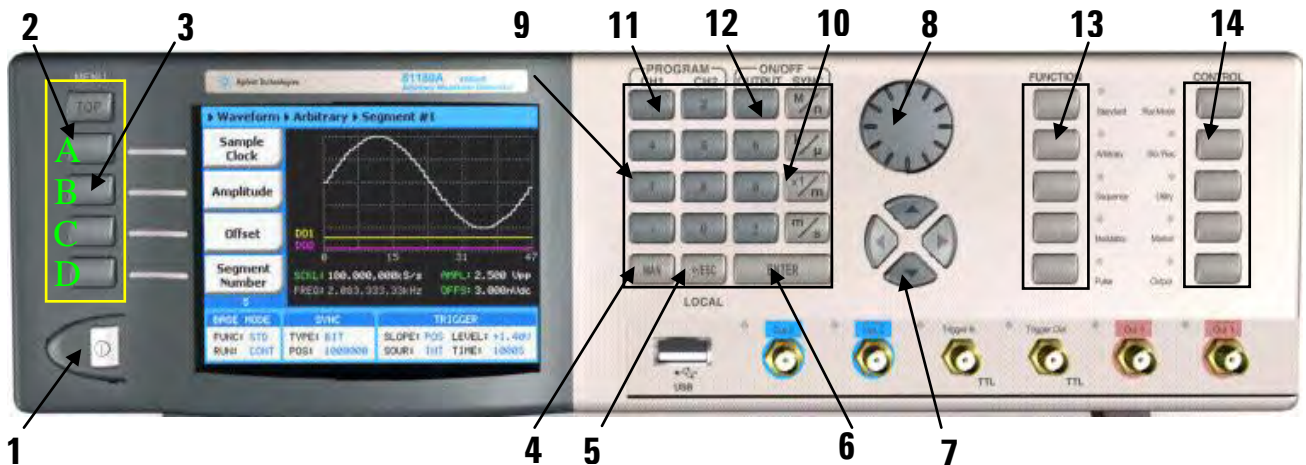

**Figure 3-2: 81180A Front Panel Operation**



The index in the following paragraphs point to the numbered arrows in *Figure 3-2*.

---

**Power Switch** – Toggles 81180A power ON and OFF

**Menu Top** – For certain functions, selects the root menu. This button is disabled during parameter editing

**Menu Soft Keys** – These select parameter to be audited

These buttons are disabled during parameter editing

**MAN** – Manual trigger button, used in lieu of an external trigger signal

**<-Esc / (Local)** – Has two functions:

When in edit mode, cancels edit operation, restore last value and returns to the main function screen

When operating the 81180A from a remote interface, none of the front panel buttons are active except the Local button. When depressed, it restores control to front panel buttons

**Enter** – Has two functions:

When multiple parameters are displayed on the screen, the cursor and the dial scroll through the parameters. Pressing Enter selects the parameter for edit. After the parameter has been modified, the Enter button locks in the new variable and releases the buttons for other operations

When a parameter is modified, Enter can be used to replace the x1 suffix key

**Cursor UP, Down, Left and Right** – Has two functions:

When multiple parameters are displayed on the screen, the cursor and the dial scroll through the parameters.

When parameter is selected for editing, cursor buttons right or left move the cursor accordingly. Cursor buttons up or down modifies parameter value accordingly.

**Dial** – Has similar functionality as the cursor UP and Down keys.

**Numeral keypad** – These keys are used for modifying an edited parameter value.

**Parameter Suffixes (M/n, k/ $\mu$ , x1/m and m/s)** – These keys are used to place suffix at the end of the parameter. They are also used for terminating an edit operation.

**Program CH1, CH2** – Use Program CH1 to modify the screen to display channel 1 parameters. Use Program CH2 to modify the screen to display channel 2 parameters. These keys can be used only when the 81180A is not in edit mode.

**ON/OFF Output, Sync** – These keys can be used only when the 81180A is not in edit mode. The Output ON/OFF toggles output waveform, at the output connector, ON and OFF. The Sync ON/OFF toggles the sync waveform, at the

SYNC output connector, ON and OFF.

**Function** – These keys select one of 5 function menus that the 81180A can generate. The output functions are: Standard, Arbitrary, Sequenced, Modulated and Pulse. An LED lights next to the selected function.

**Control** – These keys select control menus that program the 8110A operating modes. The control menus are: Run Mode, Store/Recall, Utility, Markers and Output.

---

## 3.7 81180A Front Panel Menus

**81180A Front Panel Menus** The 81180A has over 150 parameters that control functions, modes, waveforms and auxiliary functions and an enormous combination of these parameters to define an appropriate function for a specific application. Due to the complexity of the product, the functions were divided into logical groups and sub-groups and access to these groups is provided using the soft key menus.

On the right side of the instrument there are two groups of buttons: Function and Control. The function buttons select one of five waveforms to be generated at the output connectors and cause the display to show parameters that are associated with the output function.

The other group is marked Control. These buttons control operating features and auxiliary functions that are complementary to the Function buttons.

On the left, there is a group of five soft-key buttons. These are used for accessing a specific parameter associated with the output function.

Table 3-2 and Table 3-3 list all menus that are accessible from the Function group and Table 3-3 lists all menus that are accessible from the Control group. Short explanation of the various menus is also given. Note that the descriptions in these tables are given to provide a general understanding of what is available in terms of operating the instrument. For detailed instructions, check the appropriate section of the manual.

---

Table 3-2: Front Panel Function Menus

Soft Key	Function Menu	2nd Level Menu	3rd Level Menu	Notes
Top	Standard			
A		Wave Shape	Waveform list	Select from a wave shapes list
B		Frequency	Value	Programs standard waveform frequency
C		Amplitude	Value	Programs output amplitude
C (*)		Power	Value	Available for AC coupled output path only
D		Offset	Value	Programs output amplitude offset
D (*)		Phase	Value	Parameters depend on selected shape
↓D (**)		Reset Parameters		Resets parameters for this waveform only
Top	Arbitrary			
A		Sample Clock	Value	Programs sample clock frequency
B		Amplitude	Value	Programs output amplitude
C (*)		Power	Value	Available for AC coupled output path only
C		Offset	Value	Programs output amplitude offset
D		Active Segment	Value	Selects the active arbitrary waveform segment
↓D		Jump Event	BUS / External	Selects which source will cause segment transitions
↓D		Jump Timing	Coherent / Immediate	Defines how segments transition
↓D		Wave Composer	Waveform studio	Provides access to the waveform composer
↓D		Delete Segments	Value	Deletes a selected waveform segment
Top	Sequenced			
A		Active Sequence	String	View and select the active sequence number (Not available in advanced sequence mode)
B		View Table	Table view and edit	Displays current sequence step, and properties
C		Sample Clock	Value	Programs the sequence sample clock
D		Amplitude	Value	Programs the waveform amplitude
↓D (*)		Power	Value	Available for AC coupled output path only
↓D		Offset	Value	Programs the waveform offset
		Config	Seq. Configuration	Opens a new set of configuration menus.
	Config			
A		Sequence Type	Normal / Advanced	Selects between normal or advanced sequencing
B		Advance Mode	Auto / Once / Step	Selects the advance mode
C(*)		Once Count	Value	Sequence loop counter for the once advance mode
C		Select Source	BUS / External	Defines the source that will select a sequence
D		Select Timing	Coherent / Immediate	Defines how the sequence is switched
↓D		Jump Event	BUS / Event	Selects the source to detect a jump event of a step
↓D		Sync Lock	Value	Programs sync output lock on a specific waveform or sequence

(\*) (C) Denotes conditional menu, not always shown. Available in conjunction with a specific mode only

(\*\*) ↓D Denotes, you have to scroll down to access the menu. Scroll using the arrows up or down or the dial.

**Table 3-3: Front Panel Waveform Menus (continued)**

Soft Key	Function Menu	2nd Level Menu	3rd Level Menu	Notes
Top	Modulated			
A	OFF	Modulation Type	OFF/AM/FM/Sweep	Select from a wave shapes list
B		CW Frequency	Value	Programs the modulation carrier frequency
C		Amplitude	Value	Programs output amplitude
C (*)		Power	Value	Available for AC coupled output path only
D		Offset	Value	Programs output amplitude offset
A	AM	Modulation Type	OFF/AM/FM/Sweep	Select from a wave shapes list
B		Modulation Shape	Sine/tri/squ/ramp	Programs the modulating waveform shape
C		Modulation Depth	Value	Programs the modulation depth
D		Modulation Freq	Value	Programs the modulating frequency
↓D (**)		CW Frequency	Value	Programs the modulation carrier frequency
↓D		Amplitude	Value	Programs output amplitude
↓D		Power	Value	Available for AC coupled output path only
↓D		Offset	Value	Programs output amplitude offset
↓D		Phase	Value	Parameters depend on selected shape
A	FM	Modulation Type	OFF/AM/FM/Sweep	Select from a wave shapes list
B		Modulation Shape	Sine/tri/squ/ramp	Programs the modulating waveform shape
C		CW Frequency	Value	Programs the modulation carrier frequency
D		Freq. Deviation	Value	Programs FM frequency deviation
↓D		Modulation Freq	Value	Programs the modulating frequency
↓D		Marker	Value	Programs marker frequency position
↓D		Amplitude	Value	Programs output amplitude
↓D		Power	Value	Available for AC coupled output path only
↓D		Offset	Value	Programs output amplitude offset
↓D		Phase	Value	Parameters depend on selected shape
A	Sweep	Modulation Type	OFF/AM/FM/Sweep	Select from a wave shapes list
B		Direction	Up/Down	Selects the sweep direction
C		Sweep Type	Linear/Logarithmic	Selects the sweep step
D		Start Frequency	Value	Programs the start frequency
↓D		Stop Frequency	Value	Programs the stop frequency
↓D		Sweep Time	Value	Programs the sweep time
↓D		Marker	Value	Programs marker frequency position
↓D		Carrier Shape	Sine/Triangle/Square	Selects the shape of the carrier waveform
↓D		Amplitude	Value	Programs output amplitude
↓D		Power	Value	Available for AC coupled output path only
↓D		Offset	Value	Programs output amplitude offset

(\*) (C) Denotes conditional menu, not always shown. Available in conjunction with a specific mode only

(\*\*) ↓D Denotes, you have to scroll down to access the menu. Scroll using the arrows up or down or the dial.

### 3.7.1 Pulse Menus

#### Pulse Menus

The menus that are described in *Table 3-4* are somewhat different than the pulse menus as they are relatively straightforward as each menu controls a separate, single parameter. There is a slight difference when it comes to operating a pulse generator; simple pulse generation requires just a few parameters such as: period, pulse width, and hi and low levels however, it gets complicated when the application requires transition times, pulse delays and different level control. For this purpose, the start-up menu for the pulse function is the simplest and provides access to the commonly used parameters, but as you select more complex modes, other menus are automatically turned on, allowing access to mode parameters. The default menus after reset are given in *Table 3-4*, followed by the rest of the menus that are revealed after turning on specific features of the pulse function.

The following table is presented not to show you how to use the pulse generator, but to give you a general overview of all menus available for this function. A detailed description on the pulse function is given later in this chapter.

**Table 3-4: Front Panel Pulse Function Menus**

Soft Key	Function Menu	2nd Level Menu	3rd Level Menu	Notes
Top	Pulse			
A		Period	Value	Programs pulse repetition rate
B		Width	Value	Programs the pulse width
C		High Level	Value	Programs the pulse high level
D		Low Level	Value	Programs the pulse low level
↓D (*)		Config	Pulse Configuration	Opens a new set of configuration menus.
	Config			
A		Pulse Parameters	Time / Percent	Pulse parameter settings in time or percent of period
B		Pulse Mode	Single / Delayed / Double	Programs pulse mode
C		Polarity	Normal / Complement / Inverted	Selects pulse polarity
D		Transition Type	Fast / Linear	Programs pulse transitions
↓D		Level Control	High / Low / Amplitude / Offset / Positive / Negative	Defines how the pulse levels are programmed
	Revealed			
C(*)	Delayed	Delay	Value	Programs delay for the delayed pulse mode
C(*)	Double	Delay	Value	Programs delay for the double pulse mode

↓D (*)	Linear	Leading Edge	Value	Programs rise time for the linear transition type
↓D (*)	Linear	Trailing Edge	Value	Programs fall time for the linear transition type
C(*)	Ampl/Offs	Amplitude	Value	Programs amplitude for the level control mode
↓D (*)	Ampl/Offs et	Offset	Value	Programs offset for the level control mode

(\*) (C) Denotes conditional menu, not always shown. Available in conjunction with a specific mode only

(\*\*) ↓D Denotes, you have to scroll down to access the menu. Scroll using the arrows up or down or the dial.

### 3.7.2 Control Menus

#### Control Menus

The Control menus buttons, unlike the Function menus buttons, display menus and parameters that modify the output to various run modes, turns the outputs on and off, programs markers and provides access to utility functions. You may also use these buttons to store and recall instrument settings and waveforms.

*Table 3-5* lists all menus that are accessible from the Control group. A short explanation of the various menus is also given. Note that the descriptions in these tables are provided to give you a general overview of what is available in terms of operating the instrument. For detailed instructions, check the appropriate section of the manual.

---



Table 3-5: Front Panel Control Menus

Soft Key	Control Menu	2nd Level Menu	3rd Level Menu	Notes
	Run Mode			
A		Continuous	Enable Mode	Selects between Self Armed and Armed
			Enable Source	Selects between BUS, Event or Trigger inputs
			Event Input Level	Programs the event threshold level
			Event Input Slope	Selects Positive, Negative or, Either transition
B		Trigger	Trigger Mode	Selects between Normal and Override
			Trigger Source	Selects between BUS, Event or Trigger inputs
			Trigger Level	Programs the trigger threshold level
			Trigger Slope	Programs the trigger slope
			Trigger Delay	Programs the delayed trigger and re-trigger timer
			Trigger Timer	Programs the internal timer period
			Trigger Count	Programs the burst counter value
			Smart Trigger >time	Programs the more than pulse period value
			Smart Trigger <time	Programs the less than pulse period value
			Trigger Hold off	Programs trigger hold off time
C		Gated	Gated Level	Programs the gate threshold level
			Gated Slope	Selects Positive or Negative levels
	Sto/Rec			
		Store	Target	Toggles between internal and USB
			Memory Cell	Selects the active memory cell
			Store	Defines what will be stored
		Recall	Target	Selects the source to recall setups
			Memory Cell	Selects the active memory cell
	Utility			
A		Remote Interface	Select Interface	Provides access to interface setup: GPIB / USB / LAN
			GPIB	GPIB address setting
			USB	No parameter setting
			LAN	Programs LAN IP address, subnet mask and gateway
B		System	Power on State	Selects between Default and Setup
			Brightness	Programs display brightness

(\*) (C) Denotes conditional menu, not always shown. Available in conjunction with a specific mode only

(\*\*) ↓D Denotes, you have to scroll down to access the menu. Scroll using the arrows up or down or the dial

**Table 3-6: Front Panel Control Menus (continued)**

Soft Key	Control Menu	2nd Level Menu	3rd Level Menu	Notes
C		Clocks		
			Sample Clock Feed	Programs separate or common feed
			Ext. SCLK Freq.	Prepares the external sample frequency range
			CH1 Source	Selects between Internal and External source
			CH1 Divider	Programs a dividing ratio for the external clock
			CH2 Source	Grayed out. Selection is automatic, depending on the Sample Clock Feed setting
			Ref Clock Source	Selects between Internal and External source
			Ref Clock Ext. Freq.	Prepares the external reference frequency range
D			Factory Reset	Resets all instrument parameters to factory defaults
A	Marker	CH1 – Marker 1/2	State	Toggles both marker outputs on and off
			Delay	Programs the marker delay value
			Pos.	Programs the marker position value
			Width	Programs the marker width value
			High	Programs the marker high level value
			Low	Programs the marker low level value
B		CH2 – Marker 1/2	State	Toggles both marker outputs on and off
			Delay	Programs the marker delay value
			Pos.	Programs the marker position value
			Width	Programs the marker width value
			High	Programs the marker high level value
			Low	Programs the marker low level value
C		Apply		Updates the marker memory with the above settings
A	Output	Main Output	Output CH1	Toggles the main output ON and OFF
			Output CH2	Toggles the main output ON and OFF
			Output Couple CH1	Selects between DC, DAC and AC path
			Output Couple CH2	Selects between DC, DAC and AC path
B		SYNC Output	State	Toggles the SYNC output ON and OFF
			Source	Selects between CH1 and CH2
			Type	Selects between Pulse and WCOM
			Position	Programs the SYNC position value
			Width	Programs the SYNC width value
C		X-Channel	Offset CH2->CH1	Programs channel 2 offset value referenced to CH1 1
			Skew CH2->CH1	Programs channel 2 skew value referenced to CH1
D		X-Instr.	Role	Selects between Master and Slave
			State	Turns couple state on and off
			Offset	Programs an offset between two coupled instruments

### 3.8 Enabling the Outputs

**Enabling the Outputs** For safety reasons, the main outputs default setting is OFF. The outputs can be turned on and off using either the hot keys, or the Output Menu. Please see *Figure 3-3* and disable or enable the main outputs using the procedure described below. The same procedure can be used for enabling and disabling the SYNC output.



**Figure 3-3: Enabling and Disabling the Outputs**

Press the Output button in the Control group buttons. Observe the Output display, as it appears in *Figure 3-3*.

Use the dial or arrow keys to access the required field, which will appear orange.

To edit the field press Enter. The edited field will turn white with orange borders

Use the dial or arrow keys to change the field

Press Enter again to lock in the setting

Alternately, the outputs can be turned on and off using the hot-key buttons as marked above the keypad.

While not editing any parameter, select the channel you want to turn on using the PROGRAM CH1 or CH2 keys

Press ON/OFF OUTPUT or SYNC to toggle main and sync output on and off

## 3.9 Selecting a Function Shape

### Selecting a Function Shape

There are five function shapes that the 81180A can produce: Standard, Arbitrary, Sequenced, Modulated and Pulse. The standard, modulated and pulse waveforms are computed from equations and tables that are built into the program, but for the arbitrary and sequenced functions, waveform coordinates must first be loaded into its working memory. To generate one of the function types, simply press one of the Function buttons on the right side of the product. The display will change to display parameters that are associated with the selected function. For standard, modulated and pulse functions, the output will immediately generate the selected function. Arbitrary and sequenced waveforms will be generated only after waveform coordinates have been downloaded to the working memory.



The picture in the 81180A LCD display is an icon only. The actual output waveform may look entirely different.

---

## 3.10 Changing the Output Frequency

### Changing the Output Frequency

You should be careful not to confuse waveform frequency with sample clock frequency. Frequency applies to standard waveforms only and controls waveform frequency at the output connector. The sample clock frequency parameter is valid for arbitrary and sequenced waveforms only, and defines the frequency of the generator clocks data points.

Pulse waveform period is measured in units of seconds. Standard waveform frequency is measured in units of Hz and Arbitrary waveform sample clock frequency is measured in units of Sa/s (samples per second). The frequency of a given arbitrary waveform at the output connector is dependent on sample clock frequency, the number of data points, and other specific waveform definitions.

The frequency of the output waveform will change only if a standard waveform is generated. First, select a standard waveform as described earlier and then proceed with frequency modification.

Please see *Figure 3-4* and modify frequency using the following procedure:  
Press the Frequency soft key to select the frequency parameter.

Use the numeric keypad to program the new frequency value.

Press M/n, k/ $\mu$ , x1/m or m/s to terminate the modification process.

Alternately, you can modify the frequency value with the dial and arrow keys, but then the termination of the process is by pressing Enter only.

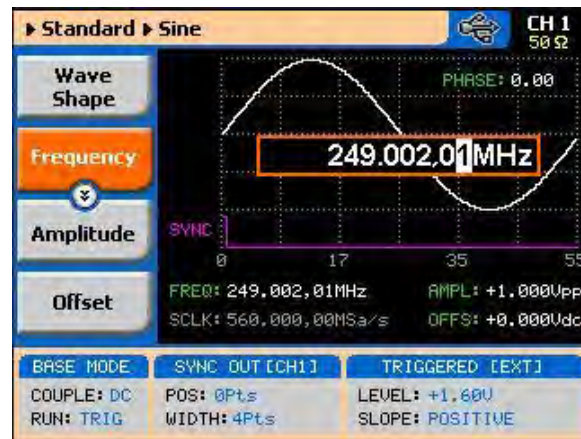

**Figure 3-4: Modifying the Output Frequency**



If you use the dial or arrow keys to modify the frequency parameter, the output is updated immediately, as soon as you modify the parameter. The final value will be locked in as soon as you press Enter. If you choose to leave the old value, press Cancel to terminate the process and discard of any change made to this parameter.

### 3.11 Changing the Sample Clock Frequency

**Changing the Sample Clock Frequency** The frequency of the sample clock will affect the output waveform only if arbitrary or sequenced waveforms are generated. First, select an arbitrary waveform as described earlier and then proceed with sample clock frequency modification.

Please see *Figure 3-5* to modify the sample clock using the following procedure:

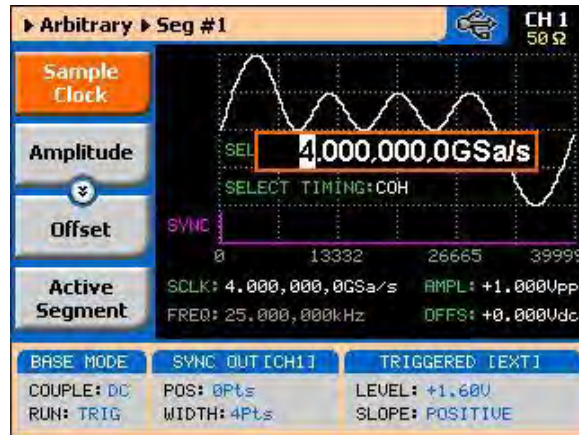

**Figure 3-5: Modifying the Sample Clock Frequency**

Press the Sample Clock soft key to select the Sample Clock parameter. Use the numeric keypad to dial the new sample clock frequency value. Press “M/n”, “k/μ”, “x1/m” or “m/s” to terminate the modification process. To select GSa/s enter the value in MSa/s (i.e. 4000 MSa/s will program 4 GSa/s). Alternately, you can modify the sample clock frequency value with the dial and arrow keys, but then the termination of the process is by pressing Enter only.



If you use the dial or arrow keys to modify the sample clock frequency parameter, the output is updated immediately, as soon as you modify the parameter. The final value will be locked in as soon as you press Enter. If you choose to leave the old value, press Cancel to terminate the process and to discard of any change made to this parameter.

## 3.12 Selecting an Output Couple

### Selecting an Output Couple

The 81180A provides three different output stages that can be selected for different applications. The direct DAC output has the fastest rise time and therefore, can be used for applications requiring dc-coupled bandwidth of more than 1 GHz and low-level signals. The amplified DC path has lower transition times, but higher amplitudes, and can be used for applications requiring dc-coupled moderate bandwidth of up to 600 MHz. The AC-coupled path has an equalizing filter that extends its bandwidth to over 1.5 GHz. Both the direct DAC and the DC paths generate differential outputs: normal and inverted, but the AC path is generated as a single-ended output.

You can modify the output couple path (see *Figure 3-6*) using the following procedure. Note that each channel can be programmed to a different setting. Press the Output button in the Control group buttons. Observe the Output display, as appears in *Figure 3-6*.

Use the dial or arrow keys to access the required field, which will appear orange.

To edit the field, press Enter. The edited field will turn white with orange borders.

Use the dial or arrow keys to change the field.

Press Enter again to lock in the setting.



**Figure 3-6: Selecting an Output Couple Path**

### 3.13 Programming the Amplitude and Offset

#### Programming the Amplitude and Offset

Output amplitude and offset can be programmed independently and separately for each channel. The active channel is displayed on the upper right corner of the LCD display.

When the display shows **CH 1** on the upper right corner, you are currently programming channel 1 parameters. Keypads "1" and "2" are used as hot keys for channel selection. When not editing any parameter, press key "2" to program channel 2 parameters.

When the display shows **CH 2** on the upper right corner, you can proceed with channel 2 programming.

The amplitude and offset parameters are duplicated in multiple screens. When changed for a specific function shape, the new value is updated on all screens, regardless of the selected function shape. *Figure 3-7* shows an example of how

to program the amplitude for channel 1. The same procedure can be used for channel 2 and for the offset parameter. Note that the example is given for a standard waveform function, but the same procedure will be used for all other functions.

Press the Standard button in the Function group.

Press Enter to edit the Amplitude value.

Use the numeric keypad to program the new value.

Press “m” for mV, or “x1” for volts to select the suffix letter.

Press Enter to lock in the value.

Alternately, you can modify the amplitude value with the dial and arrow keys, but then the process must be terminated by pressing Enter.

Offset is programmed the same way as amplitude, except select Offset from the soft key menus to access the offset parameter. Using the DC and DAC output paths, the amplitude and offset values are programmed in units of volts.



If you use the dial or arrow keys to modify the amplitude or offset parameters, the output is updated immediately, as soon as you modify the parameter. The final value will be locked in as soon as you press Enter. If you choose to leave the old value, press Cancel to terminate the process and to discard of any change made to this parameter.

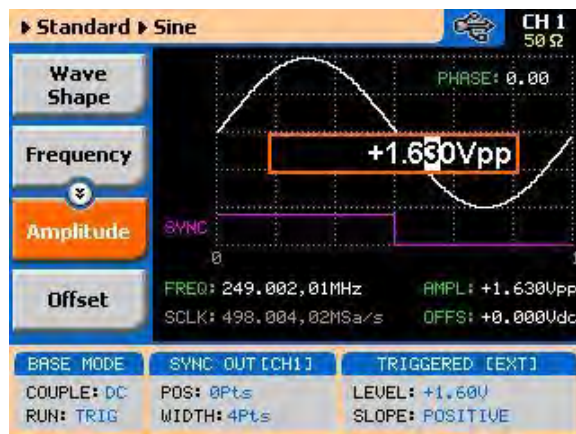

**Figure 3-7: Programming Channel 1 Amplitude Example**



## 3.14 Programming the Output Power

### Programming the Output Power

As explained above, the amplitude and offset are parameters that are associated with the DC and DAC output couple paths. When using the AC output couple path, the output is programmed in units of power (dBm). However, note that the power level is correct for sine waveforms only; all other waveforms can still use the ac path and power setting but the power value will correspond to an equivalent sine waveform only.

Output power can be programmed independently for each channel. The active channel is displayed on the upper right corner of the LCD display.

When the display shows **CH 1** on the upper right corner, you are currently programming channel 1 parameters. Keypads "1" and "2" are used as hot keys for channel selection. While not editing any parameter, press key "2" to program channel 2 parameters.

When the display shows **CH 2** on the upper right corner, you can proceed with channel 2 programming.

The power parameter is duplicated in multiple screens. When changed for a specific function shape, the new value is updated on all screens, regardless of the selected function shape. *Figure 3-8* shows an example how to program the power level for channel 1. The same procedure can be used for channel 2 power parameter. Note that the example is given for a standard waveform function, but the same procedure will be used for all other functions.

Change the output couple path to AC, as shown in *Figure 3-6*.

Select the Power soft key.

Press Enter to edit the power value.

Use the numeric keypad to program the new value.

Press "x1" or Enter to lock in the value.

Alternately, you can modify the power value with the dial and arrow keys, but then the termination of the process is by pressing Enter.



If you use the dial or arrow keys to modify the amplitude or offset parameters, the output is updated immediately, as soon as you modify the parameter. The final value will be locked in as soon as you press Enter. If you choose to leave the old value, press Cancel to terminate the process and discard any change made to this parameter.

---

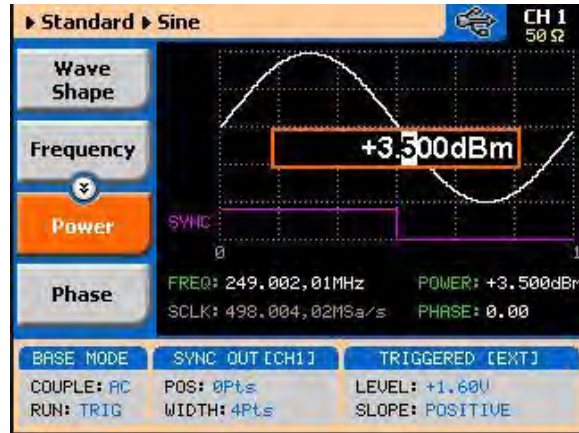

Figure 3-8: Programming Channel 1 Power Example

### 3.15 Selecting a Run Mode

**Selecting a Run Mode** The Model 81180A offers four run modes: Continuous, Triggered and Gated.

The selected waveform is repeated continuously, when the instrument is set to operate in Continuous mode. The continuous output can be armed to turn on and off using an Event input and a remote interface, consequently controlling the timing of the waveform from external sources. The operating mode defaults to continuous and self-armed mode after reset. The continuous signal can be aborted at any time, using a remote command.

Triggered, Gated, and Burst modes require an external signal to initiate output cycles. In some cases, an internal trigger generator is available to generate the required trigger stimuli, without the need to connect to external devices. *Figure 3-9* shows the run mode options screen. Press the Run Mode key in the Control group and then select the required run mode option using one of the soft keys on the left of the screen.

Descriptions of the various run modes and the parameters associated with each run mode are given in the following paragraphs.



A selected run mode option applies to all of the available function shapes. For Separate SCLK feed mode, each channel can be programmed to a different run mode option. For Common SCLK feed mode, where both channels are synchronized, selecting a specific run mode option for one channel automatically updates the mode to match the other channel.

---



Figure 3-9: The Typical Run Mode Display (Continuous Mode Shown)

### 3.15.1 Continuous Run Mode

**Continuous Run Mode** The continuous run mode is useful for applications that require continuous generation of waveforms. The continuous run mode is the factory default setting, so every time the instrument defaults to this mode.

Using the continuous run mode, the 81180A generates waveforms at its output terminals without control when the waveform starts or stops. This is a normal requirement for most applications, however, some test routines require precise control over waveform timing and in this case the instrument has two enable modes: Self-Armed and Armed.

The self-armed is the standard continuous mode that is widely used and is customary on most waveform generators. This mode does not require special handling, as the output will commence with waveform generation as soon as the output is turned on. The Armed mode needs an event signal to begin waveform generation.

Description of the various controls in the Continuous Run Mode display is given below. Refer to *Figure 3-9* throughout this description. To access the required parameters, use the dial or the up/down buttons. When the selected parameter is highlighted, press the enter key and use the up/down buttons to select the required option. Press Enter to complete the action and lock the selected mode.

**Enable mode** – defines if the generator will be self-armed or armed to commence with waveform generation. Control signals are disabled during self-armed operation, so waveforms are generated continuously at the output terminals as soon as the output function is selected and the output is turned on.

When selecting the Armed mode, the generator goes into the idle state, where the output resides on either a dc level, waveform segment, or certain

sequence, depending on the selected output function. The generator will transition from idle to waveform generation immediately upon receipt of an enable signal, and will cease waveform generation immediately after receipt of an abort signal. *Table 1-1* in Chapter 1 lists the idle waveform for the various output functions as well as the source options of the enable and abort signals.

**Enable Source** – this parameter affects the generator only when placed in Armed mode. It defines from where the 81180A is expected to receive the enable signal. It has three options: BUS – a remote command from the host computer, EVENT – a valid signal at the rear-panel event input. Note that the parameters for the event input are programmed from the continuous menu and therefore, it is highly recommended that the continuous armed mode be used in conjunction with the event input. The trigger input parameters are programmed from the trigger run mode display and so it is less convenient to use this input with the continuous armed run mode.

**Event Input Control** – this group is used for programming the threshold level and the edge sensitivity for the rear-panel event input. The threshold level is programmable from -5 V to 5 V and the slope can be selected from positive, negative or either transitions.

---

### 3.15.2 Triggered Run Mode

**Triggered Run Mode** In Triggered mode, the output remains at a DC level and waits for a valid trigger event to initiate an output cycle. Each time a trigger occurs, the 81180A generates one complete output waveform. At the end of the output cycle, the output resumes position at a DC level that is equal to the amplitude of the first point of the waveform.

The instrument may be triggered from one of the following sources: front panel TRIG IN, front panel Manual button, rear panel event input and a remote command such as \*TRG. When placed in EXT (external) trigger source, remote commands are ignored and the instrument monitors the TRIG IN connector or the MAN TRIG control. When in BUS, the hardware inputs are ignored and only remote commands can trigger the instrument. Once initiated, the waveform can be left alone to complete its output cycle or aborted using a remote command. *Table 1-2* in Chapter 1 lists the idle waveform for the various output functions as well as the source options of the initiate and abort signals.

Description of the various controls in the Triggered Run Mode display is given below. Refer to *Figure 3-10* throughout this description. To access the required

parameters, use the dial or the up/down buttons. When the selected parameter is highlighted, press the enter key and use the up/down buttons to select the required option. Press Enter to complete the action and to lock the selected mode.



**Figure 3-10: Trigger Run Mode Parameters**

**Trigger Options** – has two fields: Mode and Source. These two fields are explained below.

**Mode** – the mode field selects between NORM and OVER. NORM defines the normal trigger sequence where every trigger generates a waveform cycle however, triggers are ignored for the duration of the output waveform. OVER defines a trigger override mode where triggers are accepted, regardless if the waveform has been completed or not, and a new cycle initiated.

**Source** – defines for the instrument from where it should expect to receive the trigger signal. Only one source for a trigger signal is legal and therefore, all other inputs are disabled automatically. The source options are: EXT, BUS, INT and EVENT.

EXT enables the front panel trigger input, BUS enables remote commands, INT turns on one of the internal timed auto-triggers and EVENT enables the rear panel event input. Additional description of the internal timed auto-trigger generators is given below.

**Trigger Parameters** – has five fields: Level, Slope, Delay, Timer and Count. These fields are explained below.

**Level** – use this field to program the threshold level for the trigger input. This adjustment is necessary if your trigger signal is riding on a dc offset, positive

or negative. The level is programmable from -5 V to 5 V.

**Slope** – defines edge sensitivity for the trigger input. The trigger input can be programmed to trigger on the rising, trailing or even both edges.

**Delay** – “0” setting defines no delay, any other number turns on the delayed trigger function. The delay field is used for the delayed trigger function, when the instrument is using external triggers but it is also used for the delayed auto-trigger function when the instrument is programmed to its internal trigger timer. The delayed trigger function is explained in detail in the following section.

**Timer** – programs the period of the internal timed auto-trigger generator. Additional information is given below.

**Count** – defines how many cycles will execute from a single trigger event. The counter can be programmed to generate a burst of 1 to 1,048,576 output cycles.

**Smart Trig** – has three fields: >time, <time and Holdoff. The smart trigger filter can zoom in on a certain pulse widths featuring only values below, above or in-between to be regarded as valid trigger signals. The smart trigger fields are explained below.

>time – use this field to program the “more than” pulse width time that will pass through the filter as a valid trigger event. OFF disables this filter.

<time – use this field to program the “less than” pulse width time that will pass through the filter as a valid trigger event. OFF disables this filter.

Note that if both filters are ON, the smart trigger will consider pulse width values “less than” and “more than” as a gate entry for legal trigger events.

**Holdoff** – use this field to program a holdoff period where first trigger disables the input for the programmed holdoff value and only then allows entry to a legal trigger event.

---

### **Using the Delayed Trigger**

The delayed trigger function, when enabled, delays the start of the output waveform for a pre-determined period following a valid trigger. The delay time value is programmed in units of sample clock periods from 0 to 8,000,000 samples. When the delay value is set to “0”, the delayed trigger function is turned off.

Note that even with the delay set to OFF, the output is always delayed from the trigger signal by a value that is specified as “system delay”. The system delay is normally small, but should always be considered as part of the overall delay period. Refer to Appendix A for the system delay specification. Also note that the delayed trigger function operates in conjunction with external trigger inputs only.

---

### Using the Built-in Auto-Trigger Generators

The correct way of using the 81180A in applications that require synchronization between system components is in conjunction with external trigger events. In this case, another component in the system generates a trigger signal, either hardware or software that stimulates the output of the generator exactly at the time that the signal is required in the loop. In addition, the 81180A can be used as a system administrator that generates stimulating signals to the rest of the system and for this purpose; the instrument has a built-in timer that generates internal triggers at pre-determined intervals. The built-in trigger generator has no reference from the main sample clock and therefore, the clock is asynchronous with the output waveform.

In fact, there are two built-in auto-trigger generators within the 81180A that each behave differently, but both are derived from the same trigger generator circuit. These are: Timed internal trigger generator and Delayed internal trigger generator.

**Timed Internal Trigger Generator** – generates equally spaced periodical and asynchronous triggers. The Timer field in the Trigger Run Mode displays programs on the timer interval in units of seconds ranging from 100 ns to 20 seconds. When programmed to this mode, all other inputs to the trigger circuit are disabled to prevent interference from external devices. The timer interval is measured from waveform start to waveform start and therefore, the period of the internal timer value must be larger than the period of the output signal.

**Delayed Internal Trigger Generator** – this function is similar to the timed internal trigger generator in the way that it generates periodical and asynchronous triggers that are equally spaced, however, the delay is programmed in units of sample clock periods and measured between waveforms. Using the delayed internal trigger generator, there is no need to worry about waveform period vs. delay period because the delay is always measured from the end of one waveform to the start of the next one.

There is also another advantage when using this function, because although the trigger generator is asynchronous with the output waveform, the delay is synchronous and therefore there is no jitter of  $\pm 1$  sample clock period due to

the digital error common to all other systems.

The delayed internal trigger generator can be programmed from 152 sample clock periods to 8,000,000 sample clock periods, provided that the numbers are integers and divisible by 8.

### 3.15.3 Gated Run Mode

#### Gated Run Mode

In gated mode, the output remains at a DC level and waits for a valid gate event to initiate an output cycle. Each time a gate opens the 81180A generates output waveforms. When the gate closes, the output completes the waveform and resumes position at a DC level that is equal to the amplitude of the first point of the waveform.

The instrument may be gated from one of the following sources: front panel TRIG IN, front panel Manual button, or rear panel event input. Once initiated, the waveform can be left alone to complete its output cycle or aborted using a remote command. *Table 1-3* in Chapter 1 lists the idle waveforms for the various output functions, as well as the source options of the initiate and abort signals.

Description of the various controls in the Gated Run Mode display is given below. Refer to *Figure 3-11* throughout this description. To access the required parameters, use the dial or the up/down buttons. When the selected parameter is highlighted, press the enter key and use the up/down buttons to select the required option. Press Enter to complete the action and lock the selected mode.



**Figure 3-11: Gated Run Mode Parameters**



Gated Parameters – has two fields: Level and Slope. These fields are explained as follows:

**Level** – use this field to program the threshold level for the trigger input. This adjustment is necessary if your gating signal is riding on a dc offset, positive or negative. The level is programmable from -5 V to 5 V.

**Slope** – defines polarity of the gate. The trigger input can be programmed to gate on positive levels or on negative levels. Note that the positive and negative slope definition does not apply to absolute levels, but to relative levels. For example, if the trigger level is set at 1 V and the slope is set to positive, any level at the trigger input that is above 1 V is considered true (gate open) and anything below 1 V is considered false (gate closed).

---

### 3.15.4 Abort

#### Abort

The abort button appears only in continuous run mode and when the Enable Mode is set to Armed and the Enable Source is set to Event . The function of the abort soft key is to stop the waveform at a specific time. The waveform can be aborted using a remote command as well, but then the enable source must be set to BUS.

The Abort button and the Continuous Run Mode display that makes this button operational is shown in *Figure 3-12*. Place the instrument in Continuous run mode, select Armed as the Enable Source and select EVENT as the source for the enable signal. The generator will commence with waveform generation immediately after a valid event signal is applied to the Event input. The waveform will stop at the output immediately after you press the Abort soft key.

---



Figure 3-12: Typical Continuous Run Mode Display with the Abort Soft Key

### 3.16 Using the Manual Trigger

#### Using the Manual Trigger

The manual trigger allows you to trigger or gate the 81180A directly from the front panel. This button is active only when the generator is programmed to accept trigger stimuli from an external trigger source. In triggered run mode, a single push on the button initiates an output waveform. In gate run mode, the output generates waveforms as long as you press and hold the MAN button. The waveforms will cease to generate immediately after you release the button.

### 3.17 Using the SYNC Output

#### Using the SYNC Output

For safety reasons, every time you toggle the power to the 81180A OFF and ON, the SYNC output defaults to OFF. If you want to use the SYNC output, you must turn it on immediately after you power up the generator. You can turn the SYNC on using the ON/OFF SYNC hot key as was explained earlier in this chapter or you can do it from the Outputs menu shown in *Figure 3-13*. To access the SYNC output menus press the Output button in the Control group on the right of the instrument and then select the SYNC OUTPUT soft key. The SYNC output has parameters that you can modify: State, Source, Type, Position and Width. The functions of these parameters are explained below.

**State** – controls the state of the SYNC output ON and OFF. When the SYNC output is turned on, the LED next to the output terminal is lit, indicating that a SYNC signal is present at this output. OFF turns off the light, but leaves a low impedance path from the output terminal.

**Source** – selects the channel from where the SYNC output is derived, CH1 or CH2. Single channel versions do not have this control.

**Type** – defines the shape of the SYNC waveform. There are two options to select from this field: Pulse or WCOM. The pulse has a minimum width of 4 waveform points and its position along the waveform can be adjusted, as well as its width. The WCOM type SYNC output (waveform Complete) has a fixed width that cannot be modified, nor moved from its original position.

**Position** – applied to the pulse type only. This parameter defines the position of the SYNC pulse along the output waveform. The position is programmed in units of waveform points (or sample clock periods). Placement resolution is 4 points. As default, the sync signal is positioned at the beginning of the waveform.

**Width** – applies to the pulse type only. This parameter can modify the width of the SYNC pulse from a minimum of 4 waveform points to the maximum length of the waveform in increments of 4 points.



**Figure 3-13: SYNC and Filter Parameters**

## 3.18 Synchronizing Channel 1 and Channel 2

### Synchronizing Channel 1 and Channel 2

The model 81180A-002 comes with two channels, each of which can be operated as a stand-alone waveform generator. There are very few circuits and controls that are shared by the two channels, namely: display, remote interfaces, external sample clock and trigger input connectors and the SYNC output. In addition, each channel can be programmed to operate uniquely in terms of functions, modes and parameters.

For example, channel 1 can generate continuous sequences of arbitrary waveforms and channel 2 can generate triggered pulse patterns. There are no limitations how one channel is programmed, compared to the other channel, as long as the connectors that are shared by the channels do not interfere in the way they are used.

The two channels can be synchronized to operate from a single sample clock source and in this case, the output frequency is identical and the generator provides a tight relationship between phase offset and waveform start. Still, while synchronized, the two channels can still generate different waveform functions, amplitudes and dc offsets and the same run mode option can be selected for both.

Synchronizing the two channels requires a single operation – modifying the SCLK Feed from separate to common. This is done from the Utility ->Clock ->Sample Clock Feed field as shown in *Figure 3-13*. When the selected parameter is highlighted, press the enter key and use the up/down buttons to select the required option. Press Enter to complete the action and to lock the selected mode.

The cross-channel parameters that control phase offset and skew are discussed in the following paragraphs. There are other parameters in this display that relate to the EXT SCLK Source and Divider and the external reference clock; these are discussed later in the relevant sections of this chapter. Notice, however, that when the Common SCLK Feed is selected, access to CH2 parameters are denied because there is only one sample clock source left to control in this mode.

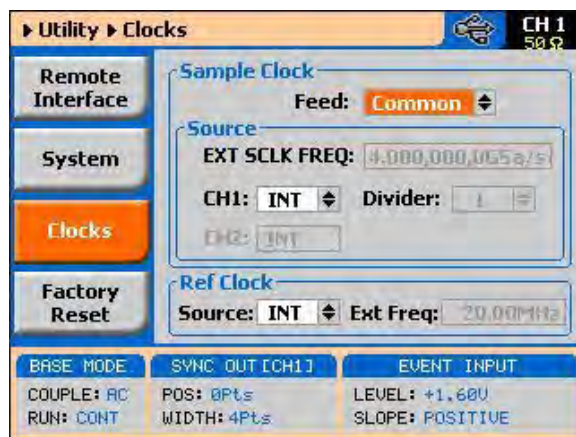
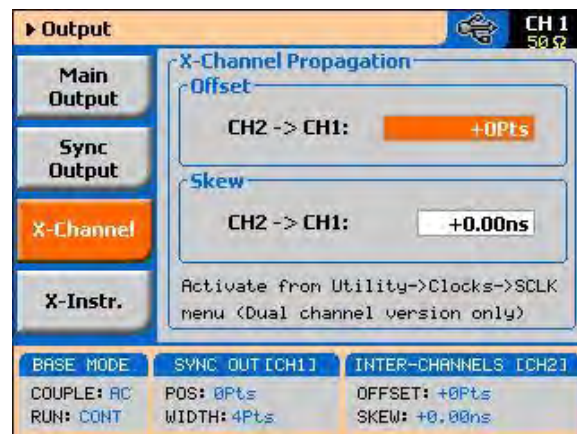

**Figure 3-14: Modifying the SCLK Feed to Common**

### 3.19 Controlling Cross-Channel Propagation

#### Controlling Cross-Channel Propagation

Cross-channel propagation is relevant only after the two channels have been synchronized and are fed from the same sample clock source. To access the Cross-Channel Propagation menu, press the Output key in the Function group and then press the X-CHANNEL soft key button. The display, as shown in *Figure 3-15*, now provides access to the synchronization parameters. If you did not synchronize the two channels, this display will be grayed out and you will have no access to the fields. Use the up/down buttons to highlight the required parameter and then press Enter. Modify the parameter and press Enter again to complete the action and to lock the selected value. There are two parameters that you can modify from this display: Offset CH2 ->CH1 and Skew CH2 ->CH1. These parameters are explained below.



**Figure 3-15: Controlling Cross-Channel Propagation**

**Offset CH2 -> CH1** – with channel 1 as reference, this allows programming of an offset value in units of waveform points (or sample clock periods). The CH2 -> offset can be programmed from 0 to the  $\pm$ full length of the output waveform.

**Skew CH2 -> CH1** – with channel 1 as reference, it defines the skew between the channels in units of ns. The skew is programmable from 0 ns to  $\pm 3$  ns with increments of 10 ps.

## 3.20 Using External Clock References

**Using External Clock References** In cases where synchronization to other instruments in a system is required, you have two options: use an external clock source for the reference clock or replace the internal sample clock generator entirely with an external clock generator. Either way, this is a major twist in the 81180A basic operation because, if for any reason, you leave one or both parameters selected from an external source and do not apply the necessary signal to the input, the operation of the generator will be impeded without visual references that something is wrong.

The SCLK and the reference clock source menus were placed in the Utility menu, as shown in *Figure 3-16*. Change these settings only if you are absolutely sure that another reference source is available at the appropriate inputs. Note that the sample display shows that all clocks are internal and therefore, some of the fields that are associated with the external references are grayed out.



**Figure 3-16: Modifying the SCLK and 10MHz Clock Source**

### 3.20.1 Using an External SCLK Source

**Using an External SCLK Source** The SCLK input is useful for applications requiring improved phase noise or clock stability. Normally, by using a near-perfect source, the phase noise of the 81180A can typically be improved by a factor of >20 dBc/Hz. The external sample clock input is an SMA connector that is located on the rear panel. It accepts signals within the frequency range of 2,000 MHz to 4,200 MHz. There is only one input that can be used for one channel or another and by both channels simultaneously. Note that the channels do not have to be synchronized to use a single external clock feed.

As was described before and shown in *Figure 3-16*, access the External Sample Clock parameters from the Utility menu. When the selected parameter is highlighted, press the enter key and use the up/down buttons to select the required option. Press Enter to complete the action and to lock the selected mode.

As shown in *Figure 3-17*, there are three parameters that can be accessed in the Sample Clock Source group: EXT SCLK FREQ and CH1 Source and Divider. These are explained below.

**EXT SCLK FREQ** – this field becomes active only after you select an external source feed to one of the channels. This field is necessary for the instrument to establish a frequency range for the internal phase lock loops and therefore must be programmed near or exactly as the external source frequency. *Figure 3-17* shows an example of a setup that provides external feed to channel 1 with an external frequency of 4.000,000 GHz.

**CH1 Source** – use this field to select between INT (internal) or EXT (external) sample clock feeds. Updating the EXT SCLK FREQ field with the external frequency value is necessary for the external sample clock feed function to operate correctly.

**CH1 Divider** – Since there is only one input for the external sample clock, feeding the same frequency to both channels is somewhat limiting if different frequencies need to be generated from each channel. The divider field accepts values in the form of  $2^n$ , from 1 to 256, that will divide the external sample clock frequency before it is applied to the internal circuits.



**Figure 3-17: Using an External Sample Clock Example**

## 3.20.2 Using an External Clock Reference Source

### Using an External Clock Reference Source

The External Reference input is useful for applications requiring synchronization to other components in a system, and can be used to improve clock stability and accuracy, but it does not necessarily improve phase noise. The external reference input is a BNC connector that is located on the rear panel. It accepts signals within the frequency range of 10 MHz to 100 MHz. There is only one input that feeds both sample clock generators simultaneously. Note that the channels do not have to be synchronized to use the external reference feed.

As was described before and shown in *Figure 3-16*, access the External Reference Clock parameters from the Utility menu. When the selected parameter is highlighted, press the enter key and use the up/down buttons to select the required option. Press Enter to complete the action and to lock the selected mode.

AS shown in *Figure 3-18*, there are two parameters that can be accessed in the Reference Clock group: Source and EXT FREQ. These are explained below.

**Source** – use this field to select between INT (internal) or EXT (external) reference clock feeds. Note that updating the EXT FREQ field with the external frequency value is necessary for the external reference clock feed function to operate correctly.

**EXT FREQ** – this field becomes active only after you select an external reference feed. This field is necessary for the instrument to establish a frequency range for the internal phase lock loops and therefore must be programmed near or exactly as the external reference source frequency.

*Figure 3-18* shows an example of a setup that provides external feed frequency of 100 MHz.

---





Figure 3-18: Using an External Sample Clock Example



#### TIP

The internal reference frequency is 100 MHz and therefore, any lower frequency that will be used as an external reference will degrade the phase noise of the output signal. It is therefore recommended that frequencies near 100 MHz be used as reference.

## 3.21 Generating Standard Waveforms

### Generating Standard Waveforms

The majority of applications require the use of common waveforms such as: sinusoidal, triangular and square. In fact, these are the only waveforms that function generators can produce and therefore, one should expect that these waveforms be available even in a complex generator such as this. The 81180A, being a completely digital instrument, has a library of built-in waveforms that allow generation of these basic waveforms, plus many more.

By default, the 81180A is programmed to generate standard waveforms so when you rest the generator, it will commence with generating a standard sine waveform as soon as the output is turned on. Besides the standard sine waveform, the instrument has a built-in library of waveforms referred to as Standard Waveforms. The meaning of this term is that these waveforms have standard characteristics, commonly associated with these waveforms. For example, sine waveform has known spectral and power distribution that could be compared to published mathematical equations. The quality of the generator determines the proximity of the waveform generation to its pure mathematical expression.

Figure 3-19 shows a list of waveforms that the instrument can generate, however, don't forget that the waveforms are generated digitally from either

lookup tables or formulated from standard equations and therefore, each time a new waveform is selected, expect to have a slight delay between the time the waveform was selected to when it is being generated at the output connector.

---

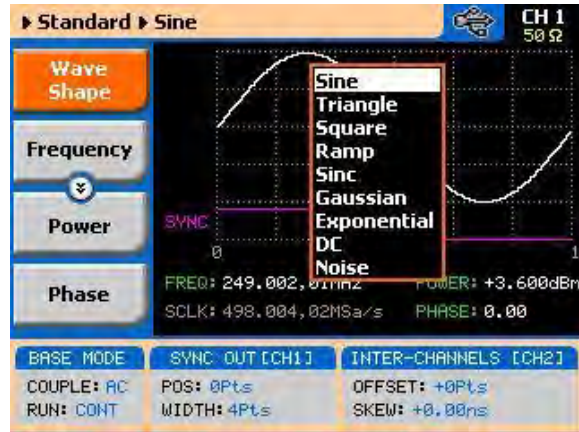

**Figure 3-19: Built-in Standard Waveforms Menu**

The 81180A has a library of 9 standard waveforms: Sine, Triangle, Square, Ramp, Sinc, Gaussian, Exponential, DC and Noise. Some of the parameters for these waveforms can be modified to fine-tune the waveforms for specific applications. For example, changing the sine start phase of the 2nd channel can create a 2-phase sine system. The standard waveforms and the parameters that can be modified are summarized in the following paragraphs.

---

### 3.21.1 Sine Wave

#### Sine Wave

The sine waveform is the most commonly used waveform. The waveform is generated from a lookup table that has 1000 points and as a result, the sine waveform is generated with 1000-point accuracy up to about a frequency setting of 250kHz (output frequency = sample clock frequency / number of points). As frequency is increased above 250kHz, the number of points is automatically reduced up to a point where filters are switched in to reconstruct the waveform. The technique of generating sine waves above a certain frequency is not within the scope of this manual, however, one should remember that above certain frequencies the waveform loses purity and quality because the number of points that are available to construct the waveform are inversely proportional to the output frequency. This statement is true for all standard waveforms and is the reason for limiting the upper frequency of certain waveforms.

There are certain menus that provide access to sine waveform parameters. These are:

**Frequency** – programs the frequency of the sine waveform. Note that at low frequencies (up to about 500 kHz), when you modify the frequency parameter, the output responds with coherent change. However, at higher frequencies, the waveform has to be re-computed every time and therefore, when you modify the frequency, the output wanders until the waveform is re-computed and restored to full accuracy.

**Amplitude** – programs the amplitude of the output waveform. Note that amplitude and offsets can be programmed freely within the specified amplitude window, as explained in the Programming Amplitude and Offset section of this chapter. Note that setting the amplitude parameter in this menu overrides amplitude settings in all other menus.

**Offset** – programs the offset of the output waveform. Note that offset and amplitude can be programmed freely within the specified amplitude window, as explained in the Programming Amplitude and Offset section in this chapter. Note that setting the offset parameter in this menu overrides offset settings in all other menus.

**Phase** – sets the start phase of the output waveform. You will not be able to see any change in the waveform if you generate a continuous sine waveform. However, if you place the generator in triggered run mode, the output will start the sine wave generation from a point defined by the Phase parameter. The start phase is programmed in units of degree.

**Reset Parameters** – Resets the sine wave parameters to their original factory defaults.

---

### 3.21.2 Triangle Wave

#### Triangle Wave

The triangle waveform is a commonly used waveform. The waveform is generated from a lookup table that has 8000 points and as a result, the triangle waveform is generated with 8000-point accuracy up to about a frequency setting of 500 kHz (output frequency = sample clock frequency / number of points). As frequency is increased above 500 kHz, the number of points is automatically reduced.

The triangular waveform is reasonable up to about 40 MHz, where 10 points are available to generate its shape. As the number of points further decrease,

the shape becomes distorted to a point where it is no longer usable. There are specific menus providing access to triangle waveform parameters. These are:

**Frequency** – programs the frequency of the triangle waveform. Note that at low frequencies (up to about 500 kHz), when you modify the frequency parameter, the output responds with coherent change. However, at higher frequencies, the waveform has to be recomputed every time and therefore, when you modify the frequency, the output wanders until the waveform is recomputed and then restored to full accuracy.

**Amplitude** – programs the amplitude of the output waveform. Note that amplitude and offsets can be programmed freely within the specified amplitude window, as explained in the Programming Amplitude and Offset section in this chapter. Note that setting the amplitude parameter in this menu overrides amplitude setting in all other menus.

**Offset** – programs the offset of the output waveform. Note that offset and amplitude can be programmed freely within the specified amplitude window, as explained in the Programming Amplitude and Offset section in this chapter. Note that setting the offset parameter in this menu overrides offset setting in all other menus.

**Phase** – sets the start phase of the output waveform. You will not be able to see any change in the waveform if you generate a continuous triangular waveform. However, if you place the generator in triggered run mode, the output will start the triangle wave generation from a point defined by the Phase parameter. The start phase is programmed in units of degree.

**Reset Parameters** – Resets the triangular wave parameters to their original factory defaults.

---

### 3.21.3 Square Wave

#### Square Wave

The square waveform is a commonly used waveform. The waveform is generated from a lookup table that has 8000 points and as a result, the square waveform is generated with 8000-point accuracy up to about a frequency setting of 500 kHz (output frequency = sample clock frequency / number of points). As frequency is increased above 500 kHz, the number of points is automatically reduced.

There are specific menus that provide access to square waveform parameters. These are:

**Frequency** – programs the frequency of the square waveform. Note that at low frequencies (up to about 500 kHz), when you modify the frequency parameter, the output responds with coherent change. However, at higher frequencies, the waveform has to be recomputed every time and therefore, when you modify the frequency, the output wanders until the waveform is recomputed and then restored to full accuracy.

**Amplitude** – programs the amplitude of the output waveform. Note that amplitude and offsets can be programmed freely within the specified amplitude window, as explained in the Programming Amplitude and Offset section in this chapter. Note that setting the amplitude parameter in this menu overrides amplitude settings in all other menus.

**Offset** – programs the offset of the output waveform. Note that offset and amplitude can be programmed freely within the specified amplitude window, as explained in the Programming Amplitude and Offset section in this chapter. Note that setting the offset parameter in this menu overrides offset settings in all other menus.

**Duty Cycle** – programs the square wave duty cycle (pulse width to period ratio). The duty cycle is programmed as a percent of the period. The default value is 50%.

**Reset Parameters** – Resets the square wave parameters to their original factory defaults.

### 3.21.4 Ramp Wave

#### Ramp Wave

The ramp waveform is a special instance of the triangular waveform with a slight difference: the ramp can be adjusted for its rise and fall times. The ramp waveform is a very common waveform and is required for numerous applications. However, not being a true ramp generator, the ramp parameters are computed and programmed as a percent of the ramp period. The waveform is computed every time a parameter is modified. 8000 points are allocated for the ramp shape up to about a frequency setting of 500 kHz (output frequency = sample clock frequency / number of points). As frequency is increased above 500 kHz, the number of points is automatically reduced. The ramp waveform is reasonable up to about 40 MHz, where 100 points are available to generate its

shape. As the number of points decrease further, the resolution of the parameters is lost to a point where it is no longer usable.

There are specific menus that provide access to ramp waveform parameters. These are:

**Frequency** – programs the frequency of the ramp waveform. Note that at low frequencies (up to about 500 kHz), when you modify the frequency parameter, the output responds with coherent change. However, at higher frequencies, the waveform has to be recomputed every time and therefore, when you modify the frequency, the output wanders until the waveform is recomputed and then restored to full accuracy.

**Amplitude** – programs the amplitude of the output waveform. Note that amplitude and offsets can be programmed freely within the specified amplitude window, as explained in the Programming Amplitude and Offset section in this chapter. Note that setting the amplitude parameter in this menu overrides amplitude settings in all other menus.

**Offset** – programs the offset of the output waveform. Note that offset and amplitude can be programmed freely within the specified amplitude window, as explained in the Programming Amplitude and Offset section in this chapter. Note that setting the offset parameter in this menu overrides offset settings in all other menus.

**Delay** – sets the delay time for the ramp start. The delay is programmed as a percent of the ramp period.

**Rise** – programs the ramp rise time. The rise time is programmed as percent of the ramp period.

**Fall** – programs the ramp fall time. The fall time is programmed as a percent of the ramp period.

Note that the sum of the delay, rise and fall times cannot exceed 100%. If the sum is less than 100%, the end of the ramp will remain at a dc level until the completion of the period.

**Reset Parameters** – Resets the ramp wave parameters to their original factory defaults.

---

### 3.21.5 Sinc Wave

#### Sinc Wave

The sinc pulse (sine  $x/x$ ) waveform is a very common waveform and is required in many applications. However, not being a true pulse generator, the sinc pulse parameters are recomputed every time a parameter is changed. 8000 points are allocated for the sinc pulse shape, up to about a frequency setting of 500 kHz (output frequency = sample clock frequency / number of points). As frequency is increased above 500 kHz, the number of points is automatically reduced. The sinc pulse waveform is reasonable up to about 40 MHz, where 100 points are available to generate its shape. As the number of points further decrease, the shape of the pulse is deteriorated to a point where it is no longer usable.

There are specific menus that provide access to sinc pulse waveform parameters. These are:

**Frequency** – programs the frequency of the sinc waveform. Note that at low frequencies (up to about 500 kHz), when you modify the frequency parameter, the output responds with coherent change. However, at higher frequencies, the waveform has to be re-computed every time and therefore, when you modify the frequency, the output wanders until the waveform is recomputed and then restored to full accuracy.

**Amplitude** – programs the amplitude of the output waveform. Note that amplitude and offsets can be programmed freely within the specified amplitude window, as explained in the Programming Amplitude and Offset section in this chapter. Note that setting the amplitude parameter in this menu overrides amplitude settings in all other menus.

**Offset** – programs the offset of the output waveform. Note that offset and amplitude can be programmed freely within the specified amplitude window, as explained in the Programming Amplitude and Offset section in this chapter. Note that setting the offset parameter in this menu overrides offset settings in all other menus.

**#Cycles** – sets the number of “0” crossing cycles for the sinc function. Note that the default value is 4. Changing the value to a different number requires recalculation of the waveform and may take a few seconds until the waveform is computed and generated at the output connector.

**Reset Parameters** – Resets the sinc pulse wave parameters to their original factory defaults.

### 3.21.6 Gaussian Wave

#### Gaussian Wave

The gaussian pulse waveform is useful in many applications. The gaussian pulse parameters are re-computed every time a parameter is changed. 8000 points are allocated for the gaussian pulse shape, up to about frequency setting of 500 kHz (output frequency = sample clock frequency / number of points). As frequency is increased above 500 kHz, the number of points is automatically reduced. The gaussian pulse waveform is reasonable up to about 40 MHz, where 100 points are available to generate its shape. As the number of points decrease further, the shape of the pulse is deteriorated to a point where it is no longer usable.

There are specific menus that provide access to gaussian pulse waveform parameters. These are:

**Frequency** – programs the frequency of the sinc waveform. Note that at low frequencies (up to about 500 kHz), when you modify the frequency parameter, the output responds with coherent change. However, at higher frequencies, the waveform has to be recomputed every time and therefore, when you modify the frequency, the output wanders until the waveform is recomputed and then restored to full accuracy.

**Amplitude** – programs the amplitude of the output waveform. Note that amplitude and offsets can be programmed freely within the specified amplitude window, as explained in the Programming Amplitude and Offset section in this chapter. Note that setting the amplitude parameter in this menu overrides amplitude settings in all other menus.

**Offset** – programs the offset of the output waveform. Note that offset and amplitude can be programmed freely within the specified amplitude window, as explained in the Programming Amplitude and Offset section in this chapter. Note that setting the offset parameter in this menu overrides offset settings in all other menus.

**Exponent** – sets the exponent factor for the gaussian function. Changing the default exponent value to a different number requires recalculation of the waveform and may take a few seconds until the waveform is computed and generated at the output connector.

**Reset Parameters** – Resets the gaussian pulse wave parameters to their original factory defaults.

---



### 3.21.7 Exponential Wave

**Exponential Wave** The exponential pulse waveform is useful in applications simulating capacitor charge or discharge. Not being a true pulse generator, the exponential pulse parameters are recomputed every time a parameter is changed. 8000 points are allocated for the exponential pulse shape up to about frequency setting of 500 kHz (output frequency = sample clock frequency / number of points). As frequency is increased above 500 kHz, the number of points is automatically reduced.

The exponential pulse waveform is reasonable up to about 40MHz, where 100 points are available to generate its shape. As the number of points decrease further, the shape of the pulse is deteriorated to a point where it is no longer usable.

There are specific menus that provide access to sinc pulse waveform parameters. These are:

**Frequency** – programs the frequency of the sinc waveform. Note that at low frequencies (up to about 500 kHz), when you modify the frequency parameter, the output responds with coherent change. However, at higher frequencies, the waveform has to be recomputed every time and therefore, when you modify the frequency, the output wanders until the waveform is recomputed and then restored to full accuracy.

**Amplitude** – programs the amplitude of the output waveform. Note that amplitude and offsets can be programmed freely within the specified amplitude window, as explained in the Programming Amplitude and Offset section in this chapter. Note that setting the amplitude parameter in this menu overrides amplitude settings in all other menus.

**Offset** – programs the offset of the output waveform. Note that offset and amplitude can be programmed freely within the specified amplitude window, as explained in the Programming Amplitude and Offset section in this chapter. Note that setting the offset parameter in this menu overrides offset settings in all other menus.

**Exponent** – sets the exponent factor for the exponential function. Setting the exponent to a negative value inverts the exponential function. Changing the default exponent value to a different number requires recalculation of the waveform and it may take a few seconds until the waveform is computed and generated at the output connector.

**Reset Parameters** – Resets the exponential pulse wave parameters to their original factory defaults.

---

### 3.21.8 DC Wave

#### DC Wave

The DC waveform is a useful application simply requiring an accurate DC level. There are specific menus that provide access to the DC waveform parameters. These are:

**DC Level** – programs the level of the DC output function. The amplitude is programmed in units of volts and generated continuously at the output connector in way similar to the way a power supply generates its output. Note however, that the amplitude is calibrated when the output is terminated into 50Ω load impedance.

**Reset Parameters** – Resets the DC amplitude parameter to its original factory default.

---

### 3.21.9 Noise Wave

#### Noise Wave

The noise waveform is useful in applications requiring generation of simple noise. The spectral spread of the noise is pseudo-random and is limited in its bandwidth by the bandwidth parameter. The noise parameters are recomputed every time a parameter is changed. 8000 points are allocated for the noise shape up to about a frequency setting of 500 kHz (output frequency = sample clock frequency / number of points). As frequency is increased above 500 kHz, the number of points is automatically reduced. The noise waveform is reasonable up to about 4 MHz, where 1000 points are available to generate its shape. As the number of points decrease further, the shape of the noise is deteriorated to a point where it is no longer usable.

There are specific menus that provide access to noise waveform parameters. These are:

**Amplitude** – programs the amplitude of the output waveform. Note that amplitude and offsets can be programmed freely within the specified amplitude window, as explained in the Programming Amplitude and Offset section in this chapter. Note that setting the amplitude parameter in this menu overrides amplitude settings in all other menus.

**Offset** – programs the offset of the output waveform. Note that offset and amplitude can be programmed freely within the specified amplitude window, as explained in the Programming Amplitude and Offset section in this chapter. Note that setting the offset parameter in this menu overrides offset settings in all other menus.

**Bandwidth** – sets the sample clock rate, which generates the noise. It also serves as a simple tool to limit the bandwidth of the noise to a known value. Note that while generating noise, keep in mind that the noise is generated in a certain memory size and is repeated over and over until the function is disabled. Therefore, the noise is not really random, in the purest meaning of the word.

**Reset Parameters** – Resets the gaussian pulse wave parameters to their original factory defaults.

### 3.21.10 Standard Waveforms and Run Mode Options

**Standard Waveforms and Run Mode Options** Run Mode options define if the standard waveforms will be generated continuously, triggered, or gated. Refer to the Selecting Run Modes section of this manual to learn more about these functions. *Table 3-7* provides information on the standard waveform function in conjunction with the run mode options. This table is useful, as it summarizes all the controls that start and stop the waveforms. The Glossary defines the terms used in this table.

**Table 3-7: Standard Waveforms in Various Run Mode Options**

Run Mode	Waveform	Arm Options	Idle Waveform	Enable Signal	Abort Signal	Initiate Signal	Wave Loops	Smart Trig
Continuous	Standard	Self Armed	Wave	- (*)	-	-	-	-
		Armed	DC	BUS   Event	BUS	-	-	-
Triggered	Standard	Self Armed	-	-	-	-	-	-
		Armed	DC	-	BUS	F.P.   BUS   Trigger	1-1M	Yes
Gated	Standard	Self Armed	-	-	-	-	-	-
		Armed	DC	-	BUS	F.P.   Trigger	-	-

(\*) – Not Relevant

### Glossary of Terms

**Run Mode** – defines basic instrument run mode options:

Continuous – waveform is generated continuously.

Triggered – output waits for trigger, waveform is generated once.

Gated – output waits for gating signal, waveform is generated as long as the gating signal is true

**Waveform** – standard, built-in library of standard waveforms.

**Arm Options** – defines if a waveform is self-enabled or requires a control signal to initiate.

**Self Armed** – the output does not require a control signal to generate waveforms.

**Armed** – a control signal is required to enable waveform generation.

**Idle Waveform** – defines the state of the output waveform before an event (enable, trigger or gate) initiates a waveform.

**DC** – first waveform point.

**Wave** – first waveform in a sequence.

**Enable Signal** – defines the source, from where an enable signal is expected. Affects the output only when Arm Option is set to Armed.

**BUS** – a remote command enables the output.

**Event** – a transition at the event input enables the output.

**Abort Signal** – defines the source from where an abort signal is expected.

**BUS** – a remote command aborts all output activities. This signal does not affect the generator when set to operate in self- armed mode.

**Initiate Signal** – defines the wait for the trigger entry port to initiate a waveform. Relevant for trigger and gated run modes only.

**F.P.** – a front panel push button is used to initiate a waveform or a sequence.

**BUS** – a remote command initiates a waveform or a sequence. Selecting this option automatically disables front panel operation.

**Trigger** – a valid signal at the trigger input initiates a waveform or a sequence.

**Wave Loops** – defines how many times the waveform repeats after a valid Initiate Signal.

**Smart Trigger** – defines if smart trigger features are available for a specific function.

---

## 3.22 Generating Arbitrary Waveforms

### Generating Arbitrary Waveforms

In general, the Model 81180A cannot create arbitrary waveforms by itself. If you want to use arbitrary waveforms, you must first load them into the instrument. The BenchLink Waveform Builder Pro from Agilent Technologies can be used to generate Arbitrary Waveforms and easily download them to the 81180A.

---

### 3.22.1 What Are Arbitrary Waveforms?

#### What Are Arbitrary Waveforms?

Arbitrary waveforms are generated from digital data points, which are stored in a working memory. The working memory is connected to a digital-to-analog converter (DAC) and a sample clock generator clocks the data points, one at a time, to the output circuit. In slow motion, the output generates a waveform that resembles the look of a staircase. In reality, the DAC is generating amplitude hops that depend on bit arrangement and sample clock speed. The working memory has two major properties: vertical resolution and memory depth.

**Vertical Resolution** – This term defines the precision along the vertical axis of which data points can be placed and generated by the DAC. The 81180A uses 12-bit DAC's to generate arbitrary waveforms. Converting 12 bits to precision shows that each data point can be placed along the vertical axis with a precision of 1/4,096.

**Memory Depth** – Defines how many data points can be stored for a single waveform cycle. The 81180A has a 16,000,000 basic waveform memory capacity and 64,000,000 waveform memory, as an option.

Having such large memory capacity is an advantage. Modern applications in the telecommunications industry require simulation of long waveforms without repeatable segments. The only way to create such waveforms is having sufficient memory depth. On the other hand, if you do not need to use very long waveforms but must have many other waveforms stored in your working memory, the 81180A lets you divide the memory bank to smaller segments and load different waveforms into each segment.

---

### 3.22.2 Generating Arbitrary Waveforms

#### Generating Arbitrary Waveforms

Downloading waveforms to the 81180A and managing arbitrary memory are explained in the programming section of this manual. This section assumes that you have already downloaded waveforms and want the instrument to output these waveforms.

Refer to *Figure 3-20* and use the following description to learn how to output arbitrary waveforms, as well as how to program arbitrary waveform parameters. To access the Arbitrary display, press on the Arbitrary button in the Function group. The output will immediately resume with arbitrary waveform generation and the display will be updated with arbitrary waveform parameters, as shown in *Figure 3-20*.

Note the channel you are currently programming and make sure the icon on the upper right corner agrees with your required programming sequence. Use the following procedure to modify the parameters that are associated with the arbitrary waveform function:

1. Press the soft key next to the required parameter to display the edit field.
2. Punch in the value using the numeric keypad. Be careful not to exceed parameter limits while you key the numbers.
3. Select and press a suffix.
4. Press Enter to lock in the new value.
5. Alternately, after you display the edit field, you may use the dial and/or the arrow keys to modify the field, then press Enter to lock in the new value. If you didn't make programming errors and didn't make any mistakes while downloading your waveform segment(s), then the output should generate your desired waveform.

There are four parameters that are available for programming in this window: Sample Clock, Amplitude, Offset, Active Segment, Jump Event, Jump Timing, Wave Composer and Delete Segments. These parameters are explained as follows:

**Sample Clock** – Defines the sample clock frequency for the arbitrary waveform. Information how to modify the sample clock is given later in this chapter.

**Amplitude** – Defines the amplitude of the arbitrary waveform. Note that regardless of the amplitude setting, the vertical resolution of the generated waveform is always 12 bits. Note that this parameter is replaced by the power parameter, when the output coupling is reverted to AC, and the units change from volts to dBm.

**Offset** – defines the offset value of the arbitrary waveform. Note that this parameter is eliminated when the output coupling is reverted to AC.

**Active Segment** – Defines which of the segments in the working memory is currently active at the output connector. As was discussed earlier, the working memory can be divided to 16k segments and different waveforms loaded in each segment. Any segment is available at the output connector, only if it has been selected to be the active segment.

The segment selection field lets you select any segment, regardless if it contains waveform data or not, so be careful when you select a segment

number, as it may be empty and no output will be generated.

---

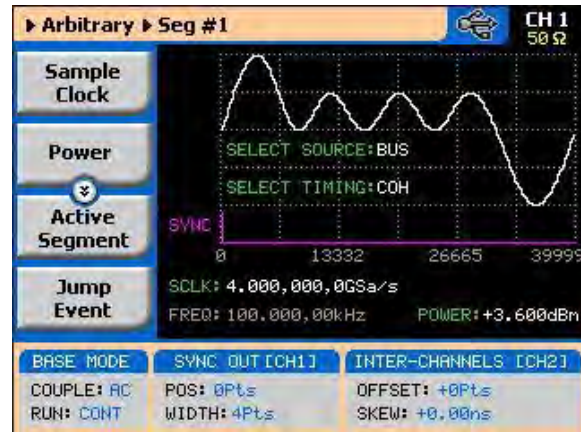

**Figure 3-20: Arbitrary Parameters Display Example**

**Jump Event** – selects between remote command, which is the default option and the rear-panel segment control connector. In case the external control is selected and signals are not hooked-up to the connector, the output automatically assumes that the first segment in the table is selected. Information how to use the external control input is given following this section.

**Jump Timing** – When a new waveform segment is selected, the generator is presented with a choice: switch at the end of the segment – coherent switch, or switch immediately without waiting for the segment to complete. The jump-timing menu provides access to this selection. Coherent is the default choice.

**Wave Composer** – opens a new display that allows creation of simple arbitrary waveforms from the front panel. The Wave Composer display is shown in *Figure 3-21*.

**Delete Segments** – Allows distractive removal of all segments from the memory. In fact, this command does not erase the memory but only removes the table that defines start and stop addresses for each segment location. If you have recorded your segment sizes you can always redefine the segment table, which will restore the original waveforms in each segment. There is, however, no way back to the original waveforms if you perform a new download action after deleting the segment table.

---





Figure 3-21: The Wave Composer Display

### Using the Dynamic Sequence / Segment Control

A Sequence / Segment control input is available on the 81180A rear panel that provides control over the replay of a specific memory segment. The control connector has 9 pins and therefore, allows replay of one of 256 waveform segments. A valid line must be asserted to validate segment change. Having the dynamic control feature, in effect, can serve as replacement of the sequence table where the real-time application can decide when and for how long a waveform will be generated.

The Sequence / Segment control input accepts TTL level signals. Bit 1 is connected to pin 1; it weighs  $2^0$  binary (decimal 1) and bit 8 is connected to pin 9 and weighs  $2^7$  binary (decimal 128) so if all lines are low, the output generates segment number 1 (the firmware counts the segments from 0 to 255) and if all lines are high, the output generates segment 256. Any combination from 0 to 255 can be produced at the inputs of this connector but the output will change only when a valid signal is asserted at pin 5 of the same connector. *Figure 3-22* shows a typical example of external Sequence / Segment control; the first valid transition selects segment 37, the second selects segment 57 and the third transitions selects segment 194.

Two Sequence / Segment control inputs are available on the rear panel, one for channel 1 and one for channel 2, and each channel can be modified to have a specific output segment. Note however, that if you intend to synchronize the outputs, the waveforms that are selected with this control must have exactly the same length. *Figure 3-23* shows the Sequence / Segment control connector and *Table 3-8* describes its pin assignments.

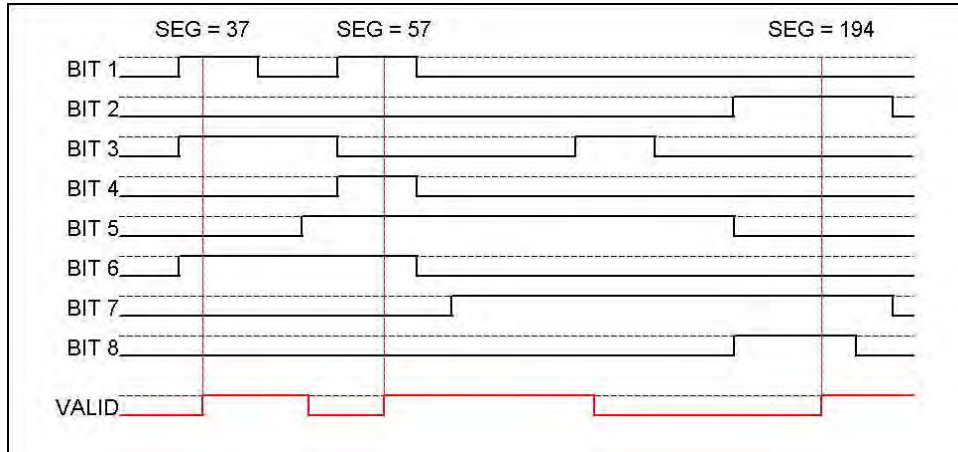

**Figure 3-22: Typical Dynamic Control Scenario**

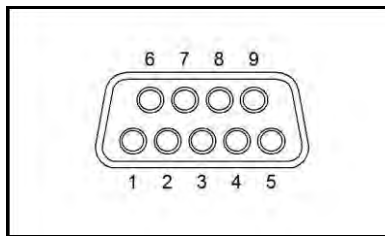

**Figure 3-23: Typical Dynamic Control Scenario**

**Table 3-8: Arbitrary Waveforms in Various Run Mode Options**

Pin Number	Assignment
1	Bit 1
2	Bit 3
3	Bit 5
4	Bit 7
5	Valid
6	Bit 2
7	Bit 4
8	Bit 6
9	Bit 8
Case	Ground

### 3.22.3 Arbitrary Waveforms and Run Mode Options

**Arbitrary Waveforms and Run Mode Options** Run Mode options define if the arbitrary waveforms will be generated continuously, triggered, or gated. Refer to the Selecting Run Modes section of this manual to learn more about these functions. *Table 3-9* provides information on the arbitrary waveform function in conjunction with the run mode options. This table is useful, as it summarizes all the controls that start and stop the waveforms. The Glossary defines the terms that were used in this table.

**Table 3-9: Arbitrary Waveforms in Various Run Mode Options**

Run Mode	Waveform	Arm Options	Idle Waveform	Enable Signal	Abort Signal	Initiate Signal	Wave Loops	Smart Trig
Continuous	Arbitrary	Self Armed	Wave	- (*)	-	-	-	-
		Armed	DC	BUS   Event	BUS	-	-	-
Triggered	Arbitrary	Self Armed	-	-	-	-	-	-
		Armed	DC	-	BUS	F.P.   BUS   Trigger	1-1M	Yes
Gated	Arbitrary	Self Armed	-	-	-	-	-	-
		Armed	DC	-	BUS	F.P.   Trigger	-	-

(\*) – Not Relevant

#### Glossary of Terms

**Run Mode** – defines basic instrument run mode options:

Continuous – waveform is generated continuously.

Triggered – output waits for trigger, waveform is generated once.

Gated – output waits for gating signal, waveform is generated as long as the gating signal is true.

**Waveform** – arbitrary waveform, waveform coordinates must be downloaded to the instrument to generate these waveforms.

**Arm Options** – defines if a waveform is self-enabled or requires a control signal to initiate.

**Self Armed** – the output does not require a control signal to generate waveforms.

**Armed** – a control signal is required to enable waveform generation.

**Idle Waveform** – defines the state of the output waveform before an event (enable, trigger or gate) initiates a waveform.

**DC** – first waveform point.

**Wave** – first waveform in a sequence.

**Enable Signal** – defines the source from where an enable signal is expected. Affects the output only when Arm Option is set to Armed.

**BUS** – a remote command enables the output.

**Event** – a transition at the event input enables the output.

**Abort Signal** – defines the source from where an abort signal is expected.

**BUS** – a remote command aborts all output activities. This signal does not affect the generator when set to operate in self- armed mode.

**Initiate Signal** – defines the wait for trigger entry port to initiate a waveform. Relevant for trigger and gated run modes only.

**F.P.** – a front panel push button is used to initiate a waveform or a sequence.

**BUS** – a remote command initiates a waveform or a sequence. Selecting this option automatically disables front panel operation.

**Trigger** – a valid signal at the trigger input initiates a waveform or a sequence.

**Wave Loops** – defines how many times the waveform repeats after a valid Initiate Signal.

**Smart Trigger** – defines if smart trigger features are available for a specific function.

### 3.23 Generating Sequenced Waveforms

#### Generating Sequenced Waveforms

In general, the Model 81180A cannot create sequenced waveforms by itself. If you want to use sequenced waveforms, you must first load them into the instrument. The 81180A is supplied with a waveform creation and editing utility. Besides waveform creation, this utility has instrument control features and sequence table generator panel. To generate a sequence, you must first download waveforms to the instrument, generate a sequence table and download the sequence table to the instrument. The BenchLink Waveform Builder Pro from Agilent Technologies can be used to generate Arbitrary Waveforms, generate sequence tables and easily download them to the 81180A.

Detailed information on the structure of the arbitrary waveform and the commands that are needed to download arbitrary waveforms to the 81180A is given in the Programming Reference Chapter. There, you can also find information how to create and download sequence tables using SCPI programming commands. Information in this chapter will give you a general idea what sequenced waveforms are all about.

Step	Segment Number	Repeat Count	Jump Flag
1	4	2	1
2	8	4	0
3	10	8	0
4	12	11	0
5	2	1	0

SCLK: 4,000,000,000Sa/s    POWER: +3,600dBm  
ADV. MOD: AUTO

BASE MODE    SYNC. OUT [CH1]    INTER-CHANNELS [CH2]  
COUPLE: AC    POS: 0Pts    OFFSET: +0Pts  
RUN: CONT    WIDTH: 4Pts    SKEW: +0.00ns

Figure 3-24: Sequence Table Display Example

### 3.23.1 What are Sequenced Waveforms?

**What are Sequenced Waveforms?** Sequenced waveforms are constructed from two or more arbitrary waveforms, which are linked and looped in any way you can imagine, as long as you observe the limitations set forth in the specification section of this manual.

The first thing to do before you can generate sequenced waveforms, is download waveforms to the 81180A. You may use any application to create waveform segments. Then, you can build your sequence table. An example of how sequenced waveforms work with three different waveforms is demonstrated in Chapter 1, Figures 1-7 through 1-10. Refer to *Figure 3-25* and use the following description to learn how to output sequenced waveforms as well as how to program sequence parameters.

Press the Sequenced button in the Functions group on the right side of the generator to select Sequenced waveforms as the output function type. The screen as shown in Figure 3-26 displays the output. Providing that waveforms were loaded and a table created, it will immediately commence with generating arbitrary waveforms. Note the channel you are currently programming and make sure the icon on the upper right corner agrees with your required programming sequence.

Use the following procedure to modify the parameters that are associated with the Sequenced waveforms function:

Press the soft key next to the required parameter to display the edit field.

Punch in the value using the numeric keypad. Be careful not to exceed parameter limits while you key the numbers.

Select and press a suffix.

Press Enter to lock in the new value.

---

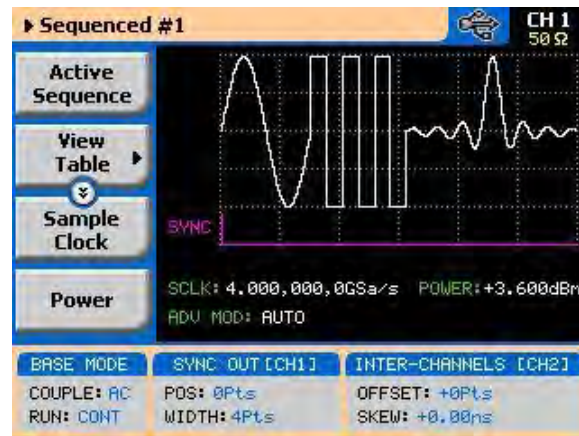

**Figure 3-25: Sequence Function Parameters**

Alternately, after you display the edit field, you may use the dial and/or the arrow keys to modify the field, then press Enter to lock in the new value. If you didn't make programming errors and didn't make any mistakes while downloading your waveform segment(s), then the output should generate your desired waveform. There are six parameters that are available for programming in this window: Active Sequence, View Table, Sample Clock, Amplitude and Offset (possibly power when AC couple is selected) and Config. These parameters are explained as follows:

**Active Sequence** – selects the active sequence to be generated at the output terminals. 1000 different sequence scenarios can be defined and replayed one at a time.

**View Table** – provides access to a new menu that has sequence table control, as shown in *Figure 3-24*. If no table was yet defined, you can define the sequence table from this menu. You can also edit an existing sequence table from this command. Information on editing the sequence table is given later.

**Sample Clock** – programs the sample clock frequency for the sequenced waveform. The final period of the complete sequence can be extracted from the following relationship:

$$\text{Sequence Duration} = 1 / (\text{SCLK} / n)$$

$n$  = the number of waveform points in the sequence, including looped waveforms.

**Amplitude** – defines the amplitude of the sequenced waveform. Might be replaced by Power, in case AC coupled has been selected for this output.

**Offset** – defines the offset of the sequenced waveform. If AC couple mode is selected for this output, offset will not be available.

**Config** – provides access to a new menu that has sequence configuration controls. The configuration menu is shown in *Figure 3-26* and its controls are described below. There are 6 control parameters in this menu: Sequence Type, Advance Mode, Once Count, Select Source, Select Timing and Jump Event.

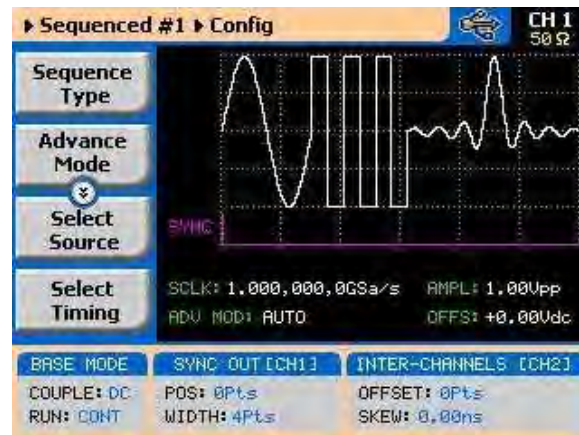

**Figure 3-26: Sequence Configuration Parameters**

**Sequence Type** – defines if the sequence is normal or advanced. The advanced mode will be discussed in detail in the following paragraphs.

**Advance Mode** – defines the advance mode for the sequence. There are three advance mode options you can select from: Automatic, Once and Stepped. These are described in detail later in the chapter.

**Once Count** – programs a count value for the Once advance mode. Additional information on this parameter will be given in the sequence advance description section. Note that this button appears only when the Once advance mode has been selected.

**Select Source** – defines the source from where one of the sequences is selected: remote command or rear panel external control. The rear-panel dynamic control is explained separately in one of the following paragraphs.

**Select Timing** – When a new sequence is selected, the generator is presented with a choice: switch at the end of the sequence – coherent switch, or switch immediately without waiting for the sequence to complete. The select timing



menu provides access to this selection. Coherent is the default choice.

**Jump Event** – defines the source from where the generator will expect a jump signal to flag that it can advance to the next step. This parameter will show only for the Auto and Step advance modes.

**Sync Lock** – Programs sync output lock on a specific waveform or sequence.

### 3.23.2 Sequence Table Elements

#### Sequence Table Elements

The sequence table specifies: Step, Wave, Repeat Count and Jump Bit. Description of the various elements within the sequence table is given below. These are explained in the following paragraphs.

**Step** - This parameter defines an index array for the sequence generator. When generating sequences, the instrument links the steps in descending order. Therefore, make sure that you enter your waveform segments in exactly the order you would like them at the output.

**Wave** - This parameter associates waveform segments with a step index. You can use different waveforms for different steps or you can use the same waveform for a number of steps. There are no limitations how you associate steps to waveforms, except you cannot program in the sequence table waveforms that were not defined earlier.

**Repeat Count** – This parameter defines how many times the waveform will loop for the selected step. For example, if you program 2, the waveform will cycle twice on the same step before transitioning to the next step.

**Jump Bit** – This field is a special code that is used in conjunction with the automatic advance mode. When the sequence generator encounters this bit, it will stop and dwell on the step until a jump even is asserted to the relevant input. Information on the jump bit is given later. “0” flags continuous, “1” flags wait-for-an-event signal.

Assuming that you already downloaded waveforms, and created and downloaded the sequence table, you can now proceed with the following instructions on how to set the 81180A to output sequenced waveforms.

**Editing the Sequence Table** If you select the View option as was described above, the sequence table will display as shown in *Figure 3-27*. If you already have a sequence table in place, you can edit the steps and modify the table per your new requirements. If you do not have a sequence table, you can construct the table from this screen. However, you first must make sure that the segments you intend to use are loaded with waveforms.

Please see *Figure 3-27*, noting the commands that are available for editing and creating a sequence table.

**Apply Changes** – After you make modifications to the sequence table, you must use this command to update the internal registers with the new table settings and output updates immediately with the new settings. Changes, if made in the table, will be updated automatically when you exit the Edit Table screen. However, the output will change to the new settings only after you re-enter the sequence function.

**Edit Step** – Provides entry point to the table. You may scroll between the fields using the arrow keys. If you want to edit a specific step, place the cursor on the step and press Enter. Edit the field as required and press Enter again to lock in the new value.

**Insert Step** – Allows adding another step to the sequence table. You have a choice of adding the step above or below the cursor line or at the end of the sequence table.

**Go to Step** – Provides entry point to the sequence table at a specific step number. Continue editing the step as described above.

**Delete Step** – Use this command to delete a specific step from the sequence. You'll be asked to confirm if you really want to delete the step, before the final execution.

**Delete Table** – Use this command to delete the entire sequence table. You'll be asked to confirm if you really want to delete the step before the final execution.

---



## TIP

Use the arrow keys or the dial to scroll through the edit parameters. The Apply Changes will remain at the top, while the others may be selectively accessed..

Step	Segment Number	Repeat Count	Jump Flag
1	251	1	1
2	2573	61	0
3	10	9	0
4	12	1	1
5	2	2462	0

SCLK: 4,000,000,000Sa/s POWER: +3.600dBm  
ADV MOD: AUTO

BASE MODE	SYNC OUT [CH1]	INTER-CHANNELS [CH2]
COUPLE: AC	POS: 0Pts	OFFSET: +0Pts
RUN: CONT	WIDTH: 4Pts	SKEW: +0.00ns

Figure 3-27: Editing the Sequence Table

### 3.23.3 Selecting Sequence Advance Mode

#### Selecting Sequence Advance Mode

As was explained above, the 81180A goes through an index of steps. It may loop a few times on a designated step and eventually, after the last step in the table, the process repeats itself. Going from step-to-step through the sequence table is done automatically by the instrument. However, there are applications requiring control of when and how the link is stepped. The 81180A has a number of sequence advance options: Auto, Once and Stepped. *Table 3-10* summarizes the various advance modes in reference to the run mode options. The various options on how to advance sequencer steps are described as follows:

**Auto** – specifies continuous advance where the generator steps continuously and automatically through the links to the end of the sequence table and then repeats the sequence from the beginning. For example, if a sequence is made of three segments – 1, 2, and 3, and AUTO mode is used, the sequence will generate an infinite number of 1, 2, 3, 1, 2, 3, 1, 2, 3...waveforms. Of course, each step waveform can be assigned a repeat counter that will cause the waveform to loop as many times as is specified in the Repeat count field.

The above description is true as long as the Jump Bits in all of the steps is set to "0". When a Jump Bit flag = "1" has been assigned to one or more steps, the waveforms dwells on this specific step until a valid jump signal event is asserted and only then the step is allowed to complete the waveform and move to the next step in the sequence.

AUTO is the default sequence advance mode.

**Once** – using this advance mode, the 81180A initiates a single sequence scenario and resumes its idle state. The idle waveform depends on the run mode, as shown in *Table 3-10*. In continuous run mode, the sequence is enabled and in triggered and gated run mode the sequence is initiated. In both cases, if the Jump Bit flag is set to "1", the generator will dwell on the selected waveform until released to the next step from a valid jump signal.

The once advance mode has a repeat loop that can be used to generate a counted burst of single sequence scenarios. This counter can be programmed from 1 to 1,000,000 loops.

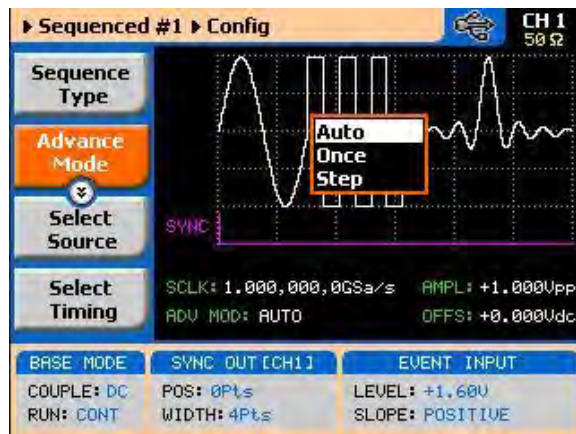

**Figure 3-28: Sequence Advance Options**

**Stepped** – this is similar to auto advance mode, except the generator places all jump bit flags to "1" and therefore, each step is advanced to the next only after a valid jump event signal has been asserted to the proper input.

To access the advance mode parameter, select Sequenced from the Function group, then select the Config soft button. The advance mode options, as shown in *Figure 3-28*, will display. Use the dial or arrow keys to scroll down to the required mode and press Enter to lock in the selected mode.

### 3.23.4 Sequences and Run Mode Options

#### **Sequences and Run Mode Options**

Run Mode options define if the sequenced waveforms will be generated continuously, triggered, or gated. Refer to the Selecting Run Modes section of this manual to learn more about these functions. *Table 3-10* provides information on the sequenced waveform function, in conjunction with the run mode options. This table is useful, as it summarized all the controls that start and stop the waveforms. The Glossary defines the terms used in this table.

**Table 3-10: Sequence Advance in Various Run Mode Options**

Run Mode	Waveform	Advance Mode	Arm Options	Idle Waveform	Enable Signal	Abort Signal	Initiate Signal	Wave Loops	Seq Loops	Jump Flag	Jump Signal	Smart Trig
Continuous	Sequenced	Auto	Self Armed	Sequence	-	-	- (*)	1-1M	-	Bit (0   1)	Event	-
		-	Armed	Wave	BUS   Event	BUS	-	1-1M	-	Bit (0   1)	Event	-
		Once	Armed	Wave	BUS   Event	BUS	-	1-1M	1-1M	Bit (0   1)	-	-
		Stepped	Armed	Wave	BUS   Event	BUS	-	-	-	-	Event	-
	Adv'd Seq.	Auto	Self Armed	-	-	-	-	1-1M	-	Bit (0   1)	Event	-
		-	Armed	Sequence	BUS   Event	BUS	-	1-1M	-	Bit (0   1)	Event	-
		Once	Armed	Sequence	BUS   Event	BUS	-	1-1M	1-1M	Bit (0   1)	-	-
		Stepped	Armed	Sequence	BUS   Event	BUS	-	-	-	-	Event	-
Triggered	Sequenced	Auto	Self Armed	-	-	-	-	-	-	-	-	-
		-	Armed	DC	-	BUS	F.P.   BUS   Trigger	1-1M	-	Bit (0   1)	Event	Yes
		Once	Armed	DC	-	BUS	F.P.   BUS   Trigger	1-1M	1-1M	Bit (0   1)	Event	-
		Stepped	Armed	DC	-	BUS	F.P.   BUS   Trigger	-	-	-	Event	Yes
	Adv'd Seq.	Auto	Self Armed	-	-	-	-	-	-	-	-	-
		-	Armed	DC	-	BUS	F.P.   BUS   Trigger	1-1M	-	Bit (0   1)	Event	Yes
		Once	Armed	DC	-	BUS	F.P.   BUS   Trigger	1-1M	1-1M	Bit (0   1)	Event	-
		Stepped	Armed	DC	-	BUS	F.P.   BUS   Trigger	-	-	-	Event	Yes
Gated	Sequenced	Auto	Self Armed	-	-	-	-	-	-	-	-	-
		-	Armed	DC	-	BUS	F.P.   Trigger	1-1M	-	Bit (0   1)	Event	-
		Once	Armed	-	-	-	-	-	-	-	-	-
		Stepped	Armed	-	-	-	-	-	-	-	-	-
	Adv'd Seq.	Auto	Self Armed	-	-	-	-	-	-	-	-	-
		-	Armed	DC	-	BUS	F.P.   Trigger	1-1M	1-1M	Bit (0   1)	Event	-
		Once	-	-	-	-	-	-	-	-	-	-
		Stepped	-	-	-	-	-	-	-	-	Event	-

(\*) – denotes not relevant

## Glossary of Terms

**Run Mode** – defines basic instrument run mode options:

Continuous – waveform is generated continuously.

Triggered – output waits for trigger, waveform is generated once.

Gated – output waits for gating signal, waveform is generated as long as the gating signal is true.

**Waveform** – Sequenced or advanced sequencing waveforms, waveform coordinates must be downloaded to the instrument and sequence tables updated to generate these waveforms.

**Advance Mode** – basic sequence advance modes, relevant for sequenced waveforms and sequenced sequences only:

Auto – a sequence is generated continuously.

Once – a sequence is generated once.

Stepped – the sequence waits for an event to jump to the next step.

**Arm Options** – defines if a waveform is self-enabled or requires a control signal to initiate.

**Self Armed** – the output does not require a control signal to generate waveforms.

**Armed** – a control signal is required to enable waveform generation.

**Idle Waveform** – defines the state of the output waveform before an event (enable, trigger or gate) initiates a waveform.

**DC** – first waveform point.

**Wave** – first waveform in a sequence.

**Enable Signal** – defines the source from where an enable signal is expected. Affects the output only when Arm Option is set to Armed.

**BUS** – a remote command enables the output.

**Event** – a transition at the event input enables the output.

**Abort Signal** – defines the source from where an abort signal is expected.

**BUS** – a remote command aborts all output activities. This signal does not affect the generator when set to operate in self armed mode.

**Initiate Signal** – defines the wait for trigger entry port to initiate a waveform. Relevant for trigger and gated run modes only.

**F.P.** – a front panel push button is used to initiate a waveform or a sequence.

**BUS** – a remote command initiates a waveform or a sequence. Selecting this option automatically disables front panel operation.

**Trigger** – a valid signal at the trigger input initiates a waveform or a sequence.

**Wave Loops** – defines how many times the waveform repeats after a valid Initiate Signal.

**Seq Loops** – defines how many times the sequence and sequenced sequences repeat after a valid Initiate Signal.

**Jump Flag** – marks a step in a sequence as either wait for an event to jump or unconditional jump.

**Bit = 0** – unconditional jump to the next step upon completion of the waveform loops.

**Bit = 1** – dwell on current step and wait for an event to jump to the next step.

**Jump Signal** – defines the entry port for a signal to cause a jump

**Event** – assigns the event input as the jump signal.

**Smart Trigger** – defines if smart trigger features are available for a specific function.

---



### 3.23.5 Using Advanced Sequencing

#### Using Advanced Sequencing

The advanced sequencing is, in fact, very similar to the standard sequence operation except, instead of waveforms, the sequence generator steps through complete sequences. Of course, it is a bit tedious to prepare so many waveforms and build so many sequence scenarios, and it would be much easier to do it from a remote computer but, you can also do simple advance sequencing from the front panel, as well.

The first time you select the sequenced waveforms function, the generator defaults to Normal sequencing. To change the mode to advanced sequencing, select the Config soft key and then the Sequence Type soft key from the configuration controls. Then select the Advanced option, as shown in *Figure 3-29*. Finally, when you select the View Table soft key, you'll notice that the table shows sequence instead of waveforms. The rest is pretty straightforward, as it operates exactly as described for normal sequence scenarios.

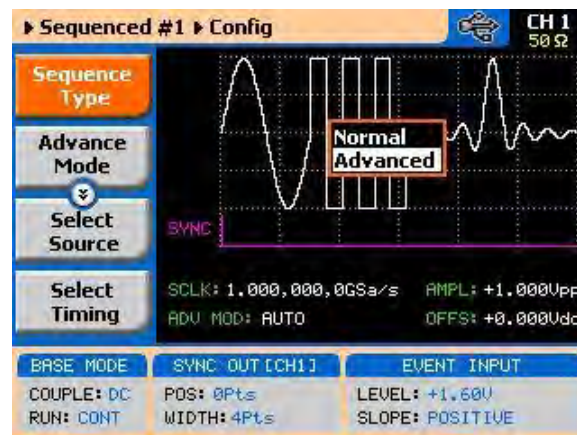

Figure 3-29: Selecting the Advanced Sequencing Option

#### Using the Dynamic Sequence Control

A control input is available on the 81180A rear panel that provides control over the replay of a specific sequence or segment. The control connector has 9 pins and therefore allows replay of one of 256 sequences. A valid line must be asserted to validate sequence change. Having the dynamic control feature, in effect, can serve as replacement of the advanced sequence table where the real-time application can decide when and for how long a sequence will be generated.

The dynamic control input accepts TTL level signals. Bit 1 is connected to pin 1; it weighs  $2^0$  binary (decimal 1) and bit 8 is connected to pin 8 and weighs  $2^7$  binary (decimal 128) so if all lines are low, the output generates segment number 1 (the firmware counts the sequences from 0 to 255) and if all line are high, the output generates sequence 256. Any combination from 0 to 255 can be produced at the inputs of this connector but the output will change only when a valid signal is asserted at pin 9 of the same connector. *Figure 3-30* shows a typical example of external sequence control; the first valid transition selects sequence 37, the second selects sequence 1 and the third transitions selects sequence 85.

Two dynamic control inputs are available on the rear panel, one for channel 1 and one for channel 2, and each channel can be modified to have a specific output sequence. Note, however, that if you intend to synchronize the outputs, the sequences that are selected with this control must have exactly the same length.

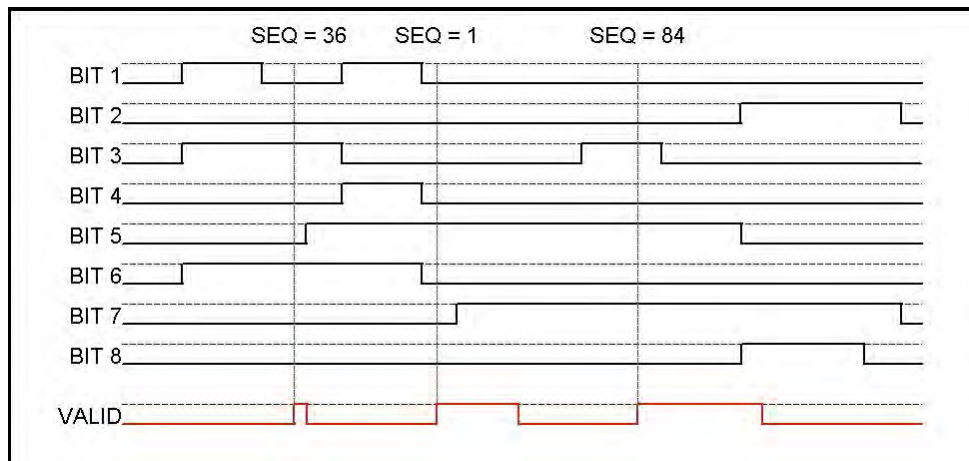

**Figure 3-30: Typical Dynamic Sequence Control Scenario**

## 3.24 Generating Modulated Waveforms

### Generating Modulated Waveforms

The 81180A, being a digital instrument, has the advantage of able to generate almost any waveform through its DAC, provided that there are enough waveform points to compute the function. Normally, complex modulation schemes will be computed on an external computer and downloaded to the generator as waveform points, but for simpler modulation schemes, the equation already resides in the instrument. The 81180A can generate AM, FM and Sweep. The advantage of these waveforms is that they are commonly used and when produced, they are extremely accurate.

The main point to keep in mind is that the modulation waveforms are computed and recomputed, every time a parameter is modified. This is a bit different from analog instruments in the way that the output must stop to recompute the waveform, and then it comes back to life. The next point to consider is the modulation barriers, because the longer and finer the modulation is, the more waveform points are required to generate the function and therefore, it takes more time to compute the waveform and load it to the memory. Normal computation time is around a few milliseconds, but for lower frequencies, it might take a few seconds.

The modulation function is turned on immediately after you press the Modulation button in the Functions group on the right side of the generator. By default, modulation is turned off and therefore, the output generates carrier wave (CW). The first modulation screen is shown in *Figure 3-31*. The modulation functions and their parameters are described as follows:

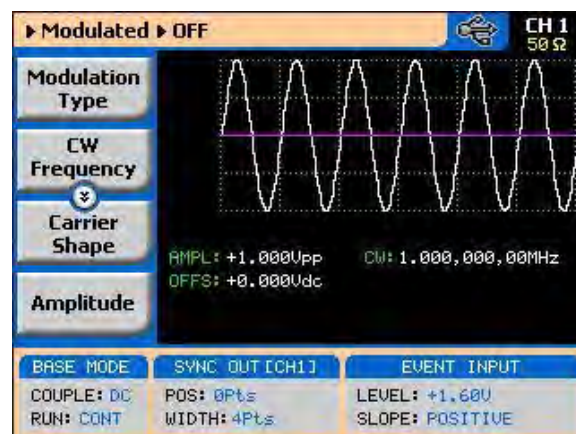

Figure 3-31: The Modulation Function Main Screen

### 3.24.1 Off

#### Off

The Modulation Off is a special instance of the modulation function, where the output is not modulated, but generates carrier waveform (CW) frequency only. CW can be sine, triangle, or square waveforms. When placed in Modulation Off, the CW is generated from the main outputs continuously. The CW parameter does not change when you switch from one modulation function to another. *Figure 3-32* shows the Modulation Off menus.

While in the Off option, there are some parameters that can be programmed for the carrier waveform:

**Modulation Type** – defines the type of modulation scheme that will modulate the carrier waveform: Off, AM, FM, or Sweep. The selected modulation scheme is generated immediately at the output terminals.

**CW Frequency** – defines the frequency of the carrier waveform. The CW parameter, as programmed in this menu is shared by all other modulation options.

**Carrier Shape** – defines the shape of the carrier waveform. The carrier shape can be selected from Sine, Triangle and Square. Note that the Carrier Shape parameter is used in all of the modulation displays, so if you change the shape for one function, it affects the other modulation displays as well.

**Amplitude** – defines the carrier amplitude level. The same level is used throughout the instrument when you move from waveform shape to another. The Amplitude parameter, as programmed in this menu, is shared by all other waveform options.

**Offset** – defines the offset level for the carrier waveforms. The same level is used throughout the instrument when you move from one waveform shape to another. The Offset parameter, as programmed in this menu, is shared by all other waveform options.

---

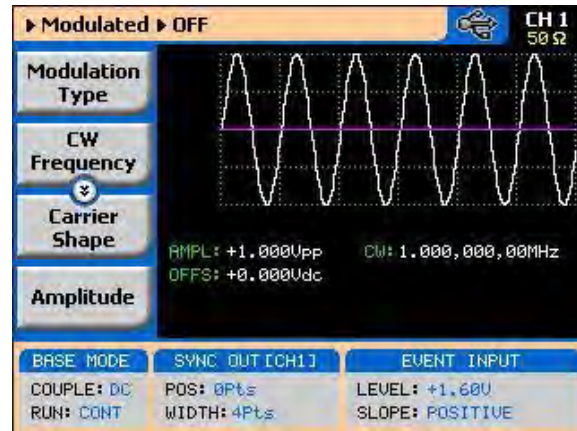

Figure 3-32: Modulation OFF Parameters



#### TIP

The values of the four parameters shown in the Modulation Off display are duplicated in all modulation panels.

### 3.24.2 AM

#### AM

The AM function enables amplitude modulation of a carrier waveform (CW). The carrier waveform is modulated by an internal waveform, normally referred to as envelope waveform. The envelope waveform can be selected from sine, triangle square or ramp shapes. When AM is selected, the menus that are associated with AM become accessible. These are shown in *Figure 3-33*.

There are other parameters that control how the CW is amplitude modulated. These are:

**Modulation Type** – defines the type of modulation scheme that will modulate the carrier waveform: Off, AM, FM, or Sweep. The selected modulation scheme is generated immediately at the output terminals.

**Modulation Shape** – defines the envelope function. There are four shapes that can be used: Sine, Triangle, Square and Ramp. The Modulation Shape menu that provides access to the selection of the envelope waveform is shown in *Figure 3-34*.

**Modulation depth** – programmed in units of % and defines the depth of the modulating envelope. Modulation depth is programmed from 0% to 100%.

**Modulation Frequency** – defines the frequency of the modulating waveform. The modulating waveform is programmed from 10mHz to 100kHz.

**CW Frequency** – defines the frequency of the carrier waveform.

**Carrier Shape** – defines the shape of the carrier waveform. The carrier shape can be selected from Sine, Triangle and Square. Note that the Carrier Shape parameter is used in all of the modulation displays, so if you change the shape for one function, it affects the other modulation displays as well.

**Amplitude** – defines the carrier amplitude level. The same level is used throughout the instrument when you move from waveform shape to another. This parameter is replaced by Power level when the output is AC coupled.

**Offset** – defines the offset level for the carrier waveforms. The same level is used throughout the instrument when you move from one waveform shape to another. This parameter will not be available when the output is AC coupled.

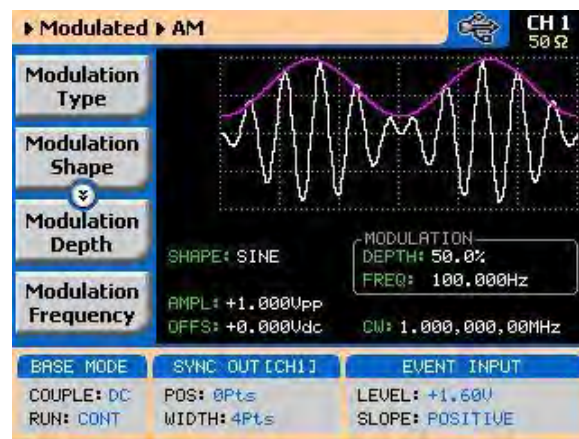

Figure 3-33: AM Menus

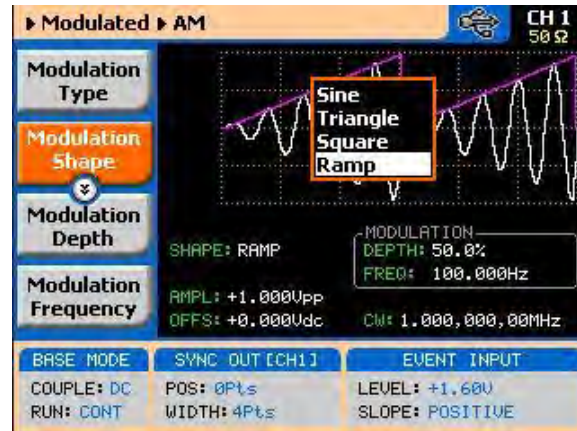

Figure 3-34: Modulating Waveform Shapes

### 3.24.3 FM

#### FM

The FM function allows frequency modulation of a carrier waveform (CW). The carrier waveform is modulated by an internal waveform, normally referred to as modulating waveform. The shape of the modulating waveform can be selected from sine, triangle, square or arbitrary waveforms.

The FM function has a number of menus that control the modulation parameters. These are shown in *Figure 3-35* and described in the following paragraphs:

**Modulation Type** – defines the type of modulation scheme that will modulate the carrier waveform: Off, AM, FM, or Sweep. The selected modulation scheme is generated immediately at the output terminals.

**Modulation Shape** – Defines the shape and type of the modulating waveform: Sine Triangle, Square and Ramp. The Modulation Shape menu that provides access to the selection of the envelope waveform is shown in *Figure 3-35*.

**CW Frequency** – defines the frequency of the carrier waveform. Using this standard FM function, the shape of the carrier waveform is always sine.

**Frequency Deviation** – defines the range of frequencies that the modulation will go through. The peak value is symmetrical around the value of the carrier waveform frequency

**Modulation Frequency** – defines the frequency of the modulating waveform. The modulating waveform is programmed from 10mHz to 100kHz.

**Marker**– programs a unique frequency where the SYNC output generates a pulse to mark this frequency.

**Carrier Shape** – defines the shape of the carrier waveform. The carrier shape can be selected from Sine, Triangle and Square. Note that the Carrier Shape parameter is used in all of the modulation displays, so if you change the shape for one function, it affects the other modulation displays as well.

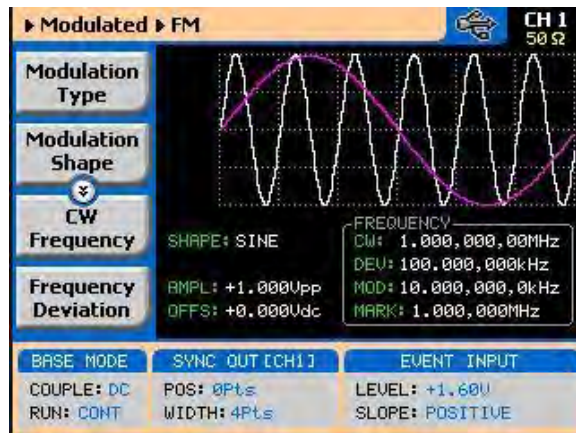

**Figure 3-35: FM Menus**

**Amplitude** – defines the carrier amplitude level. The same level is used throughout the instrument, when you move from one waveform shape to another. This parameter is replaced by Power level when the output is AC coupled.

**Offset** – defines the offset level for the carrier waveforms. The same level is used throughout the instrument when you move from one waveform shape to another. This parameter will not be available when the output is AC coupled.



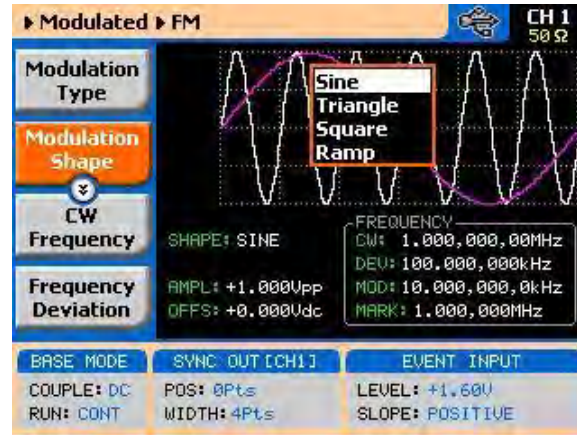

Figure 3-36: Modulation Waveform Shapes

### 3.2.4.4 Sweep

#### Sweep

Sweep modulation allows carrier waveform (CW) to sweep from one frequency, as defined by the sweep start parameter, to another frequency, as defined by the sweep stop parameter.

When you select sweep modulation, the menus, as shown in *Figure 3-37* and described in the following paragraphs, will be available for modification.

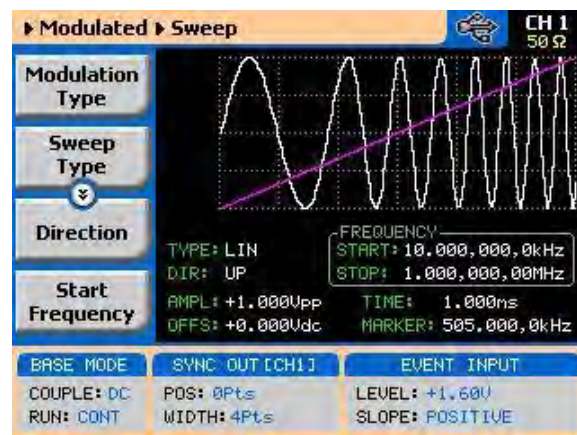

Figure 3-37: Sweep Menus

**Modulation Type** – defines the type of modulation scheme that will modulate the carrier waveform: Off, AM, FM, or Sweep. The selected modulation scheme is generated immediately at the output terminals.

**Sweep Type** – defines the sweep steps of which the frequency increments or decrements from start to stop frequencies. A choice is provided between linear and logarithmic. If you select linear sweep, the carrier waveform frequency steps through the frequencies within a time interval, which is set by the sweep time parameter. Likewise, using the logarithmic sweep type, the frequency span between the start and stop frequencies is stepped through using logarithmic steps.

**Direction** – defines the sweep direction. UP sets sweep direction from start frequency to stop frequency. DOWN reverses the sweep direction, so the output sweeps from stop frequency to start frequency.

**Start Frequency** – defines the frequency value of which the generator will start its sweep. Note that the sweep start can be at a higher frequency value, depending on the sweep direction setting.

**Stop Frequency** – defines the frequency value of which the generator will stop its sweep. Note that the sweep stop can be at a lower frequency value, depending on the sweep direction setting.

**Sweep Time** – defines the time that will lapse from sweep start to sweep stop frequencies.

**Marker** – defines a frequency of which, when transitioned through, will output a marker pulse at the SYNC output connector.

**Carrier Shape** – defines the shape of the carrier waveform. The carrier shape can be selected from Sine, Triangle and Square. Note that the Carrier Shape parameter is used in all of the modulation displays so if you change the shape for one function, it affects the other modulation displays as well.

**Amplitude** – defines the carrier amplitude level. The same level is used throughout the instrument when you move from waveform shape to another. This parameter is replaced by Power level when the output is AC coupled.

**Offset** – defines the offset level for the carrier waveforms. The same level is used throughout the instrument when you move from waveform shape to another. This parameter will not be available when the output is AC coupled.

---

### 3.24.5 Modulated Waveforms and Run Mode Options

**Modulated Waveforms and Run Mode Options** Run Mode options define if the modulated waveforms will be generated continuously, triggered, or gated. Refer to the Selecting Run Modes section of this manual to learn more about these functions. *Table 3-11* provides information on the modulated waveform function in conjunction with the run mode options. This table is useful, as it summarizes all the controls that start and stop the waveforms. The Glossary defines the terms used in this table.

**Table 3-11: Modulated Waveforms in Various Run Mode Options**

Run Mode	Waveform	Arm Options	Idle Waveform	Enable Signal	Abort Signal	Initiate Signal	Wave Loops	Smart Trig
Continuous	Modulated	Self Armed	Wave	- (*)	-	-	-	-
		Armed	DC	BUS   Event	BUS	-	-	-
Triggered	Modulated	Self Armed	-	-	-	-	-	-
		Armed	DC	-	BUS	F.P.   BUS   Trigger	1-1M	Yes
Gated	Modulated	Self Armed	-	-	-	-	-	-
		Armed	DC	-	BUS	F.P.   Trigger	-	-

(\*) – Not Relevant

#### Glossary of Terms

**Run Mode** – defines basic instrument run mode options:

Continuous – waveform is generated continuously.

Triggered – output waits for trigger, waveform is generated once.

Gated – output waits for gating signal, waveform is generated as long as the gating signal is true.

**Waveform** – modulated waveform is generated at the output.

**Arm Options** – defines if a waveform is self-enabled or requires a control signal to initiate.

**Self Armed** – the output does not require a control signal to generate waveforms.

**Armed** – a control signal is required to enable waveforms.

**Idle Waveform** – defines the state of the output waveform before an event (enable, trigger or gate) initiates a waveform.

**DC** – first waveform point.

**Wave** – first waveform in a sequence.

**Enable Signal** – defines the source from where an enable signal is expected. Affects the output only when Arm Option is set to Armed.

**BUS** – a remote command enables the output.

**Event** – a transition at the event input enables the output.

**Abort Signal** – defines the source from where an abort signal is expected.

**BUS** – a remote command aborts all output activities. This signal does not affect the generator, when set to operate in self- armed mode.

**Initiate Signal** – defines the wait for trigger entry port to initiate a waveform. Relevant for trigger and gated run modes only.

**F.P.** – a front panel push button is used to initiate a waveform or a sequence.

**BUS** – a remote command initiates a waveform or a sequence. Selecting this option automatically disables front panel operation.

**Trigger** – a valid signal at the trigger input initiates a waveform or a sequence.

**Wave Loops** – defines how many times the waveform repeats after a valid Initiate Signal.

**Smart Trigger** – defines if smart trigger features are available for a specific function.

---

## 3.25 Generating Pulse Waveforms

### Generating Pulse Waveforms

The 81180A employs a complete set of menus that are dedicated to the pulse function. Press on the Pulse in the Function group and the output will immediately be updated with the pulse waveform and the display will be modified to show pulse parameters, as shown in *Figure 3-38*.

The pulse function provides the means for designing pulses and their associated parameters, exactly as would be done on a stand-alone analog pulse generator. Note, however, that the pulse is built in the same memory as the arbitrary waveforms are being stored and therefore, changing from arbitrary to digital pulse mode and vice versa may overwrite waveforms that were downloaded to the memory.

If this is the first time that you enter this menu, the output will generate a pulse with the following properties:

- Pulse Mode: Single
- Period = 10 ms
- Pulse Width = 2 ms
- High Level = 1 V
- Low Level = 0 V
- Polarity = Normal
- Transitions = Fast

By default, pulse timing is set in units of time (seconds). However, this can be changed so that some parameters are set as ratios between the parameter to the pulse period. This option will be discussed later in this section of the manual.



The pulse shape on the 81180A LCD display is an icon only. The actual waveform at the output terminals may look entirely different.

---

The pulse generator menus provide access to all pulse parameters, just as they would be programmed on an analog pulse generator. To access the pulse parameters, use one of the soft keys. If you do not see a required parameter on the screen, press the key up or down to scroll through the menus.

There are many pulse parameters that can be displayed on the screen. However, most applications do not require that all pulse parameters be displayed and therefore, the menus were built in a way that show all of the parameters that are absolutely necessary to program the selected pulse mode.

For example, if single pulse mode with fast transitions is required, the delay, rise and fall time parameters will not be shown on the screen. Information on how to program simple and complex pulse modes is given in the following paragraphs.

The technique of changing parameter values is exactly the same as you are using to modify standard waveform parameters. Simply press the soft key that is associated with the parameter, then punch in the numbers using the numeric keyboard and complete the modification by assigning a suffix and pressing the Enter button.

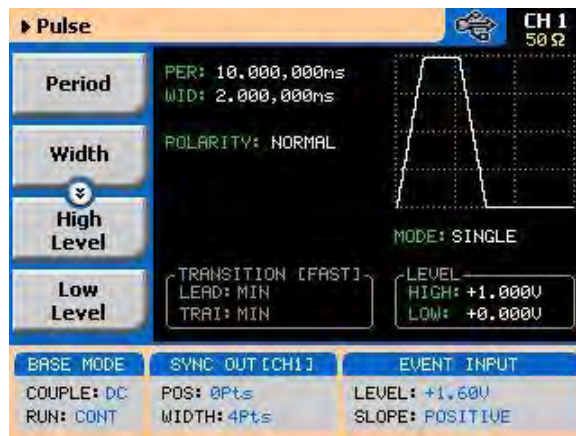

**Figure 3-38: Pulse Function Menus**

Adjusting the pulse shape with the required characteristics can only be done if all of its parameters can be adjusted both in the time and amplitude domains. The Model 81180A provides all the necessary controls to do just that. However, always keep in mind that some parameters may interfere during the programming sequence and cause setting conflicts. These setting conflicts will be discussed later in this chapter. Below you will find a list of all pulse parameters that you can access through the soft key menus.

The main menu, as shown in *Figure 3-38*, provides access to five soft key buttons: Period, Width, High Level, Low level and Config. Pressing the TOP soft key from anywhere in the pulse menus will restore the display to the one shown in *Figure 3-38*.

**Period** – programs the pulse period in unit of seconds.

**Width** – programs the pulse width in units of seconds. The pulse width can be set as a percent of the period when the Pulse Parameters option in the Config menu has been modified from Time to Percent.

**High Level** – programs the pulse high-level value in units of volts.

**Low Level** – programs the pulse low-level value in units of volts.

**Config** – provides access to a new menu that has pulse configuration controls. The configuration menu is shown in *Figure 3-39* and its controls are described below. There are five control parameters in this menu: Pulse Parameters, Pulse Mode, Polarity, Transition Type and Level Control. Each of these controls has a major impact on pulse characteristics and therefore will be addressed and explained.

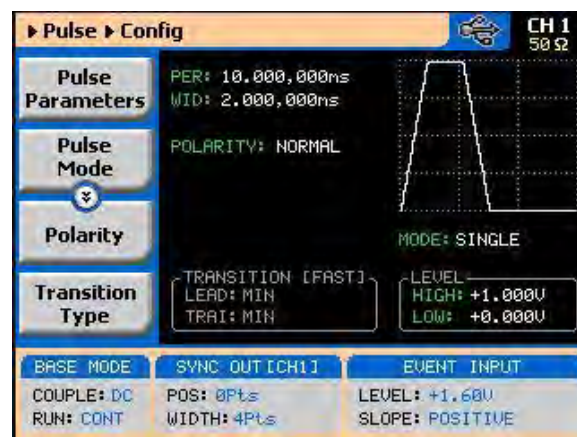

**Figure 3-39: Pulse Configuration Menus**

### 3.25.1 Pulse Parameters

**Pulse Parameters** The Pulse Parameters control lets you select if you want the pulse parameters programmed in units, time or as percent ratios to the pulse period. Pulse parameters are normally programmed in units of time and this is the default condition after reset or the first time you access this function. The advantage of using ratio is that the instrument computes the timing and keeps a fixed ratio of period-to- width whenever you change the period. The parameters available in this mode are: pulse width, pulse delay and pulse transition times. Amplitude and offset values are not affected when you select the ratio mode.

**Understanding Pulse Parameters** Standard definitions of pulse parameters are not within the scope of this manual, but it is important to understand how the Model 81180A interprets these definitions and how you should expect to see the pulse shape on monitoring devices, such as oscilloscopes.

Figure 3-40 depicts a common pulse shape as understood by most hardware engineers. The standard interpretation implies that the pulse width is measured between the edges, at the middle of the amplitude level and transitions are often specified from 10% to 90%. However, this is not always the case and some engineers, for example, prefer the 20% to 80% value as transitions and measure the high time of the pulse as the pulse width.

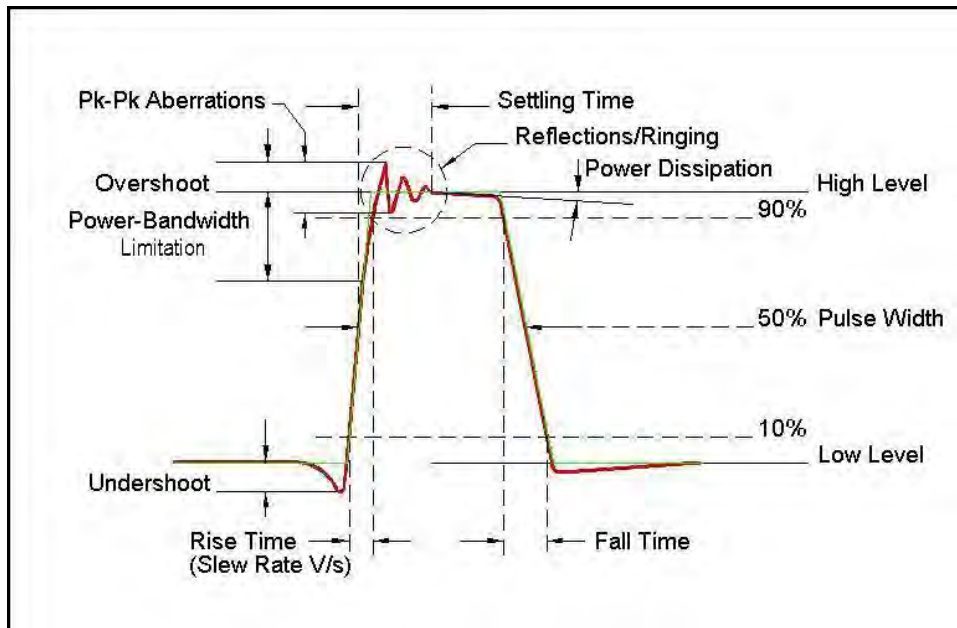

Figure 3-40: Standard Interpretation of Pulse Parameters

As mentioned above, the pulse function is computed and generated from the arbitrary memory and therefore, some of the parameters are interpreted differently, because it will take too long to compute and build digital waveforms the same way that analog components do. Standard or 81180A interpretation, once the commonality and differences are defined, will be equally simple to design pulse characteristics with the pulse generator that is available in the 81180A.

Figure 3-41 shows how the 81180A interprets the programmed pulse parameters. The differences are painted blue to highlight them. One major difference from standard analog, is that the pulse width includes the time it take to transition from low level to the time it take to transition from high level. The rest of the parameters were derived from these characteristics and should present little difficulty, especially when most of the pulse applications do not contain linear transitions, anyway.



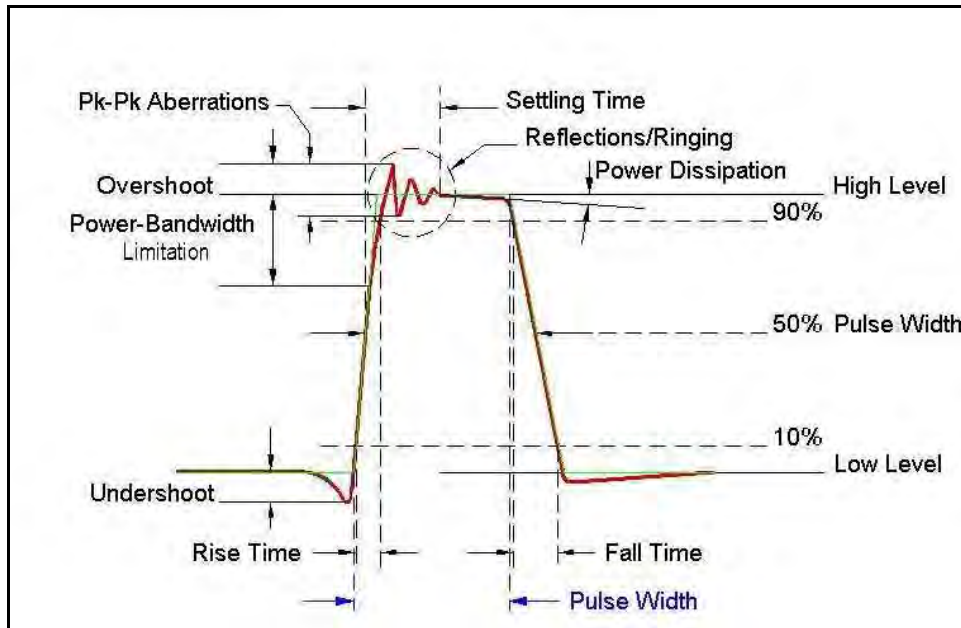

Figure 3-41: 81180A Interpretation of Pulse Parameters

### 3.25.2 Pulse Modes

#### Pulse Modes

The pulse mode menu provides access to modifying the basic shape of the pulse waveform. These are: Single Pulse, Double Pulse and Delayed Pulse. These modes and their associated parameters are discussed below. To access the Pulse Modes options, press the soft key next to this parameter. The pulse mode options will become available, as shown in *Figure 3-42*. Scroll up or down the list and press enter to complete the selection process.

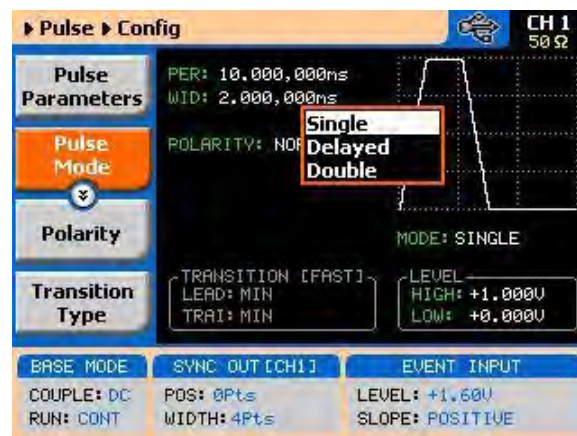
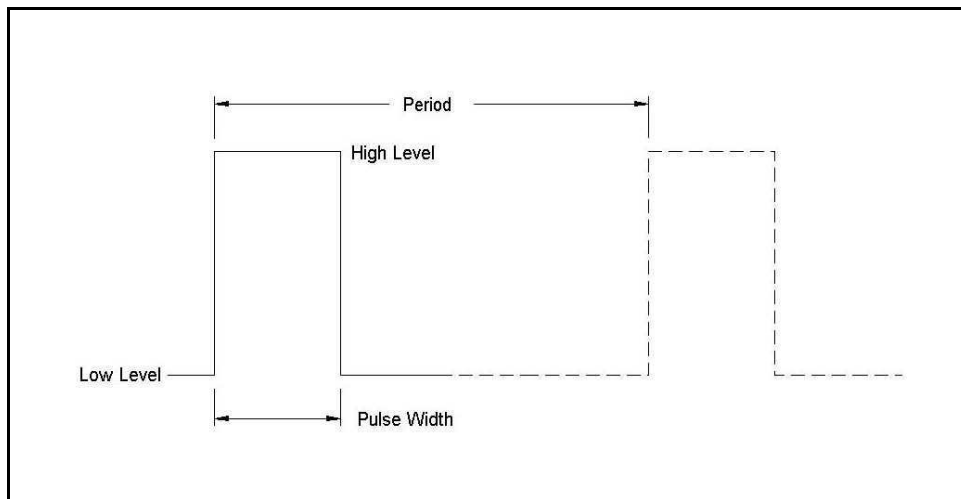

Figure 3-42: Pulse Mode Options

**Single Pulse Mode** The basic pulse mode is the Single Pulse. Single pulse defines the shape of a single pulse only. In continuous operating mode, it may appear as a string of pulses that have constant period, width and amplitude. However, the meaning of this mode is that is you place the instrument in triggered run mode and only one pulse is initiated with every trigger. The menus that are associated with the simplest configuration of the single pulse mode are: Period, Width, High and Low Levels. These parameters are discussed below. With more complex configuration, you can select linear transitions and width and amplitude modes. However, these are described separately.

*Figure 3-43* shows a typical single pulse shape and highlights all of its relevant parameters. While most of the parameters that are shown in *Figure 3-44* can be programmed and adjusted for a specific application, some characteristics of the pulse are derived from the quality of the generator and its output stage. These are specified and can be found in Appendix A.



**Figure 3-43: Single Pulse Parameters Summary**

Before you start programming pulse parameters, keep in mind that incorrect planning of your entries may cause setting conflicts that may, in turn, cause the instrument to ignore some parameters. A common example is if you try to program pulse width that is wider than the period. Therefore, always program the period first and enter other pulse parameters in descending order. A list of setting conflicts is given later in this chapter.

When Single Pulse mode option has been selected, the main pulse menus will allow access to the following pulse parameters:

**Period** – programs the pulse period in unit of seconds.

**Width** – programs the pulse width in units of seconds. The pulse width can be set as a ratio to the period when the Pulse Parameters option in the Config menu has been modified from Time to Percent.

**High Level** – programs the pulse high-level value in units of volts.

**Low Level** – programs the pulse low-level value in units of volts.

---

**Delayed Pulse Mode** The Delayed Pulse mode is a special mode that delays the pulse output after a trigger is issued. To modify the pulse mode to delayed pulse, use the procedure as given above under the Pulse Modes heading.

---

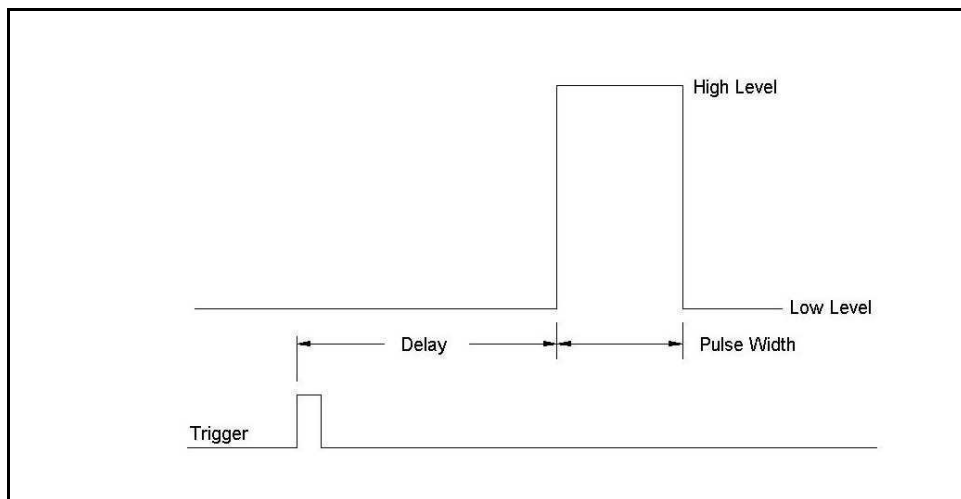

**Figure 3-44: Delayed Pulse Mode**

The menus that are associated with the simplest delayed pulse configuration are: Period, Width, High and Low Levels and Pulse Delay. The pulse delay is measured from the trigger edge to the first transition of the pulse leading edge, as shown in *Figure 3-44*.

The Pulse Delay parameter becomes available in the main pulse parameters screen only after you select the delayed pulse mode.

---



Figure 3-45: Programming the Single Pulse Delay Parameter

**Double Pulse Mode** The Double Pulse mode is a special mode that doubles pulse output into a pair of pulses at a time. In continuous run mode, the output will appear as a string of pulse pairs, separated by an interval set by the period parameter. If you place the instrument in triggered run mode, a pair of pulses is initiated with every trigger. To modify the pulse mode to double pulse, use the procedure as given above under the Pulse Modes heading.

The menus that are associated with the simplest double pulse configuration are: Period, Width, High and Low Levels and Double Pulse Delay, which sets the delay between the pairs of pulses. The double pulse delay is measured from the first pulse transition to the next pulse transition, as shown in *Figure 3-46*.

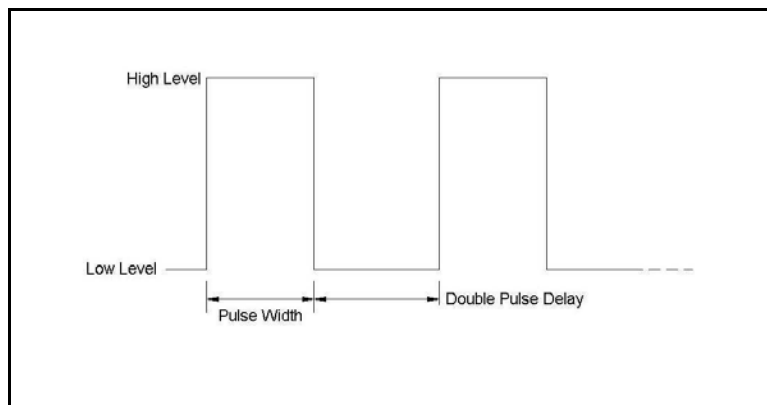

Figure 3-46: Double Pulse Mode

The double pulse delay parameter becomes available in the main pulse parameters screen, as shown in *Figure 3-47*, only after you select the double pulse mode. Note that the delay is programmed from pulse-end to pulse-start.

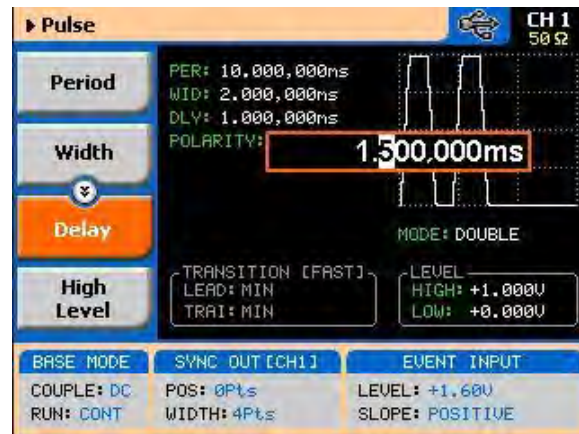

Figure 3-47: Programming the Double Pulse Delay

### 3.25.3 Programming Pulse Polarity

#### Programming Pulse Polarity

The pulse polarity parameter determines if the pulse is generated in Normal, Complemented, or Inverted shape. Pulse polarity can be selected in conjunction with any of the pulse modes. The various polarity options are shown in *Figure 3-48*.

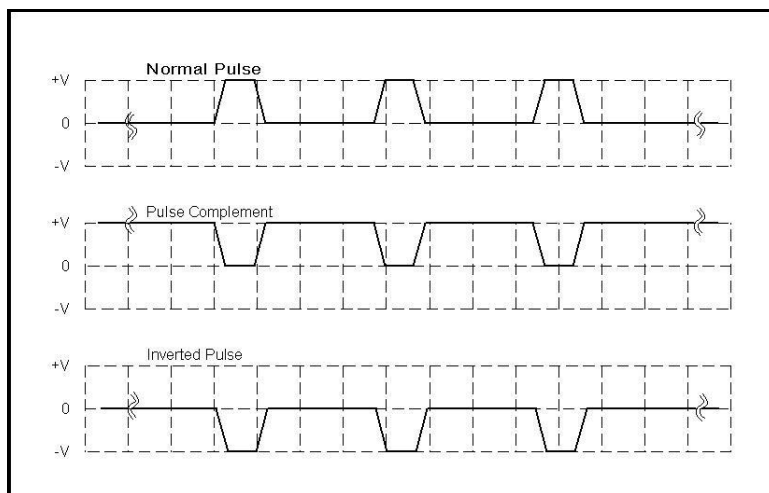

Figure 3-48: Pulse Polarity Options

As shown in this figure, the complemented shape is mirrored around the horizontal axis in a way that the high level becomes low and similarly, the low level becomes high. In complemented mode, the inversion process is symmetrical to about 50% of the value of the pulse amplitude.

In Inverted mode, the normal pulse is mirrored about the 0 V horizontal axis, positive values are converted to negative and negative values are converted to positive.

The normal pulse and the pulse complement are specifically valuable for applications requiring differential signals and therefore a dual channel like the 81180A that has this feature can easily be programmed to generate these signals. Simply set one channel to Normal and the second channel to Complemented and both signals will be generated differentially, perfectly synchronized, with no phase offset and without the slightest jitter.

Use *Figure 3-49* to access and modify the pulse polarity parameter. Note that the pulse polarity can be programmed separately for each channel and therefore, before you modify this parameter, make sure that you program the correct channel.

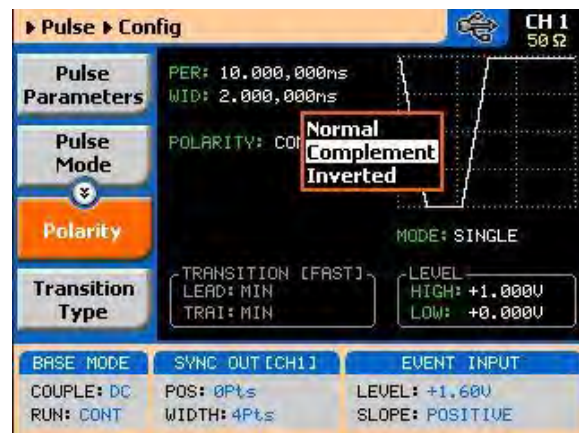

Figure 3-49: Programming the Pulse Polarity

### 3.25.4 Applying Linear Transitions

#### Applying Linear Transitions

Most of the applications that use pulse generation require that the transitions from low-to-high and from high-to-low be as fast as possible. Such transitions are normally created as a by-product of the output amplifier. General-purpose amplifiers that can drive 50 Ω loads with high amplitudes are rare, and usually the products that you can buy off the shelf either have poor drive capabilities or uncontrolled aberration capability.

For a pulse generator that generates pulses with fast transitions only, the problem is simpler, because the designer can use a switching amplifier at the output amplifier stage. It takes a very different approach to design an output stage that slows the transitions of the leading and trailing edges.

To this extent, the 81180A has a unique output amplifier stage, which allows full control over pulse transitions over a very high dynamic range of amplitudes and offsets, without the slightest degradation of the integrity of the signal.

A comparison between pulses with fast and linear transitions is shown in *Figure 3-50*. As you can see, the top train has fast transitions. These are normally in the range of  $<1$  ns and are expected to be very fast and without aberrations. The bottom pulse has linear transitions that are expected to have good linearity and slew-rate accuracy. Observe that the pulse width on the pulses that have linear transitions is measured from the first transition to high. Also note that the leading and the trailing edges can be programmed to have different transitions times.

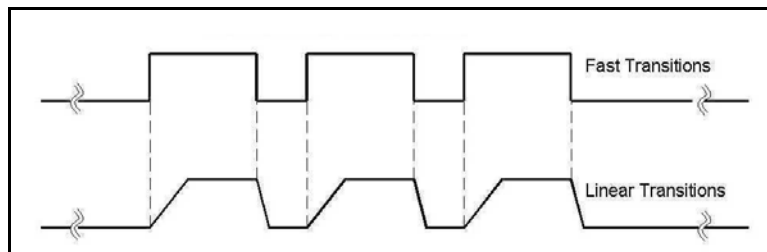

**Figure 3-50: Fast and Linear Transitions, Compared**

The menu that selects between fast and linear transitions is shown in *Figure 3-51*. The application of linear transitions affects all pulse modes. Note that you may select symmetrical transitions and in this case, programming the lead time automatically adjusts the fall time to the same value and visa versa: programming the fall time will automatically adjust the rise time value.

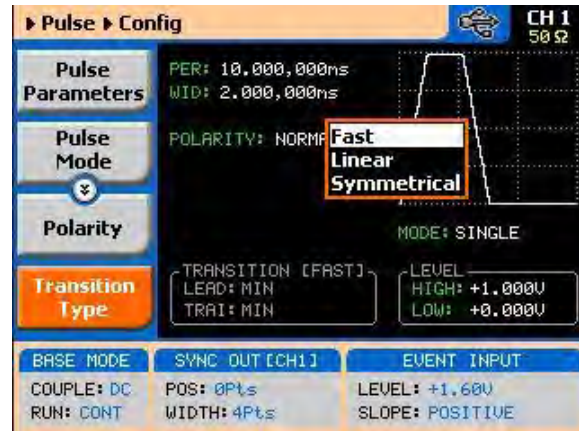

**Figure 3-51: Programming the Transition Type**

After you select the linear transition option, you'll probably want to program the transition times for the leading and trailing edges. There are some considerations to observe before you program the transitions. Then you have to make sure that the transition settings do not conflict with the pulse width settings.

For example, if you set the pulse width to 100 ns and the leading edge transition time to 120 ns, the instrument will not allow you to do the change. A list of setting conflicts is given later in this chapter.

Finally, you have to bear in mind that the transitions are programmed digitally, so there is no limitation on ranges, but if you select long transition cycles, there is danger that the generator will not have enough waveform memory to complete the waveform. These limitations are summarized in Appendix A and some are listed as errors in the following paragraphs.



**TIP**

Although not a design limitation, setting conflict may occur if the leading and trailing edges are not programmed within the same range.

After you configure the 81180A to have linear transitions, the Leading Edge and the Trailing Edge soft buttons will be visible on the main pulse display, as shown in *Figure 3-52*.





Figure 3-52: Leading Edge Programming Example

**Programming the Amplitude Level Mode**

Common waveform generators allow adjustment of the peak-to-peak amplitude plus offset, in cases where the required level is none symmetrical about the 0 V level. While this is normally acceptable for generating standard waveforms, pulsed waveform applications require additional flexibility in the way that the levels are set.

For example, one may want the baseline to stay on 0V, regardless of the top or the low peaks settings. Other applications could require separate adjustments of each level and so on.

Using the 81180A as your pulse source, you have four options to set up the pulse levels, as shown in *Figure 3-53* and explained below:

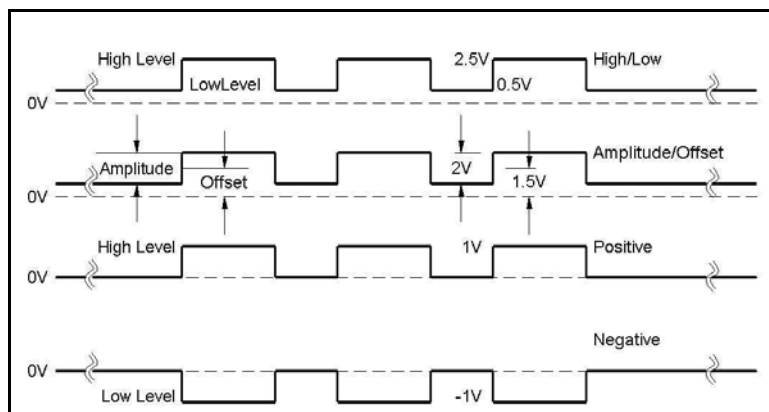

Figure 3-53: Amplitude Level Modes Options

**High/Low Levels** - This is the default option. Using this mode, you can program the high and the low levels directly, while allowing the instrument to set the internal amplitude and offset according to your selection. The maximum amplitude that can be programmed is 2 V peak-to-peak. To achieve this level, program the low level to -1 V and the high level to +1 V. Note that although the specified maximum peak-to-peak amplitude is 2 Vp-p, the high and low level cannot exceed the  $\pm 2.5$  V rail limits. Also note that the amplitude level is specified when the pulse is applied on a 50 $\Omega$  load impedance.

The only way to exceed the peak-to-peak rail limitation is by increasing the load impedance, but then expect degradation of the pulse shape. The example in *Figure 3-53* shows the high level set at 2.5 V and the low level set at 0.5 V and therefore, the resulting peak-to-peak level is 2 V.

**Amplitude/Offset** - This option allows separate modification of the amplitude and the offset. This option is very useful when you want to vary the vertical position of the pulse, but hold the peak-to-peak amplitude level fixed. The example in *Figure 3-53* shows the amplitude set at 2.5 V and the low level set at 1.5 V and therefore, the resulting waveform is exactly as was programmed in the high/low level programming example.

**Positive** - This option is very useful when you want to vary the positive position of the pulse, but hold the low level fixed at the 0 V level. The example in *Figure 3-53* shows the high level set at 1 V and the low level fixed at 0 V. Modification of the high level will not alter the low level position.

**Negative** - This option is very useful when you want to vary the negative position of the pulse, but hold the high level fixed at the 0 V level. The example in *Figure 3-53* shows the low level set at -1 V and the high level fixed at 0 V. Modification of the low level will not alter the high level position.

The amplitude level options are selected in the configuration menu, after you select the Level Control tab, as shown in *Figure 3-54*.

---

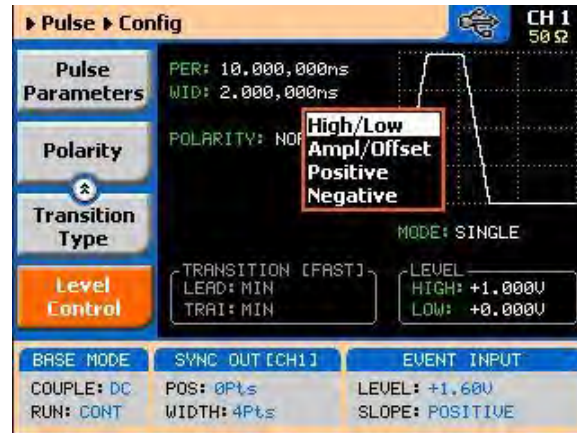

Figure 3-54: Programming the Amplitude Level Mode

## 3.26 Pulse Design Limitations

### Pulse Design Limitations

Keeping in mind that the pulse is created digitally with the use of memory points, one should understand that there are limitations to creating such pulses that evolve from this system. These limitations are summarized below.

Step increment defines resolution and period.

The pulse is being created digitally, using a sample clock generator that clocks memory points. The rate of the sample clock defines the incremental resolution. Consider that you want to generate 100 ms pulse rates with 1 ms high time pulse and the rest of the period low. In this case, the generator can select the 1 kSa/s to 10 kSa/s clock rates, because this is enough for generating a high signal of 1 ms using just 100 to 1000 memory points. However, when you want to define much smaller pulse widths at larger rep rates, the number of points that are used for the generation increases as a function of the period. The limitation is set by the number of memory points. With the standard memory model, the incremental resolution is 1 in 16,000,000. This increases to 1 in 64,000,000 if you purchased the 81180A-264.

Sum of pulse parameters cannot exceed the period.

While designing a pulse shape, keep in mind that the generator will automatically detect if you are trying to “mess with” the mathematics. Therefore, remember that the sum of all parameters cannot exceed the period. Always start your pulse design by assigning the required period first and only then work your way down the parameters list.

Only single and double pulse can be designed as a stand-alone pulse generator, the capability that is built into the digital pulse generator allows

generation of these two waveforms. This allows generation of single or double pulse patterns having a fixed high and low amplitude values. In case you need to design complex trains of pulse waveforms, you can always do it using an external utility.

Pulse peaks cannot exceed the supply voltage rails.

The maximum peak-to-peak amplitude span for a given pulse design is 2 V and a further limitation is that the positive and negative settings cannot exceed the output amplifier rails of +2.5 V and -2.5 V.

The paragraphs below summarize possible settings conflicts and devise options to undo the lockup. In case you try to program a parameter that will cause a setting conflict, the instrument will automatically detect the problem and issue an error message. In this case, the output may appear distorted and generate uncontrolled signals. Under no circumstances should you use the output when an error is displayed, even if the signal appears to look somewhat as expected, because there is no control over accuracy and signal integrity when an error message is displayed.

---

## 3.27 Settings Conflict Errors

### Settings Conflict Errors

Settings conflict errors may involve one or more parameters and there is also a chance that more than one error is embedded in the settings. For simplicity, the 81180A displays the first error it detects. In this case, the output is updated, but a red asterisk is displayed on the message bar. This symbol will remain on the top message bar until the error is cleared. A detailed description for each of the conflicting settings is given below.

The following abbreviations are used throughout the following setting conflicts descriptions:

PER – Period setting

HIL – High-level setting

LOL – Low-level setting

WID – Pulse-width setting

DEL – Delay-edge setting

TRE – Trailing-edge setting

ITRG – Period-of-internal-trigger setting

---

### 3.27.1 Amplitude Errors

**Amplitude Errors** Amplitude errors occur when attempting to program amplitude outside the specified window level. This error will occur in all run mode options. The generator will detect the following conditions:

HIL - LOL < 50 mV

HIL + LOL > 2 V

HIL > 2.5 V

LOL < -2.5 V

The minimum and maximum amplitude levels are absolute values that the 81180A can accept. The same will occur if you reverse the high and low levels, because the instrument will sense it as a negative voltage, which is obviously less than the minimum 50 mV limit.

**Corrective Actions**

Evaluate the required amplitude level and change the high and low levels accordingly.

---

### 3.27.2 Pulse Timing Errors

**Pulse Timing Errors** Pulse timing errors occur when attempting to program the period value outside the specified limits or when there is a setting conflict between the period and the leading edge transition values. The generator will detect the following conditions:

PER > 1.6 s

PER < 80 ns

LEE > WID

While the first two conditions are easy to grasp, as they are simply a matter of how the pulse parameters are specified, the last condition evolves from the way that the 81180A interprets the pulse width parameter. If you look at earlier sections of the pulse generator description, you'll notice that the pulse width includes the leading edge transition time and therefore, if you fail to take this into consideration, the generator will issue an error flag.

**Corrective Actions**

Make sure the period limits are observed

Reduce the leading-edge value

---

### 3.27.3 Pulse Linear Transition Errors

#### Pulse Linear Transition Errors

Pulse linear transition errors occur when attempting to program the leading and trailing edge values outside the specified limits. The generator will detect the following conditions:

$LEE/TRE < 1 \text{ ns}$

$LEE/TRE > 100 \text{ ms}$

$WID+TRE > 1.6 \text{ s}$

While the first two conditions are easy to grasp, as they are simply a matter of how the pulse parameters are specified, the last condition evolves from the way that the 81180A interprets the pulse width parameter. If you look at earlier sections of the pulse generator description, you'll notice that the pulse width includes the leading edge transition time and therefore, if you fail to take this into consideration, the generator will issue an error flag.

#### Corrective Actions

Make sure the leading- and trailing-edge limits are observed

Reduce the leading-edge value

Reduce the trailing-edge value

---

### 3.27.4 Pulse Delay Errors

#### Pulse Delay Errors

Pulse delay errors occur when attempting to program pulse or double pulse delay values outside the specified limits. The generator will detect the following conditions:

$DEL < 1 \text{ ns}$

$DEL > 1 \text{ s}$

$DEL+WID+TRE > 1.6 \text{ s}$  (single pulse mode)

$DEL+2*WID+2*TRE > 1.6\text{s}$  (Double pulse mode)

While the first two conditions are easy to grasp, as they are simply a matter of how the pulse parameters are specified, the last condition evolves from the way that the 81180A interprets the pulse width parameter. If you look at earlier sections of the pulse generator description, you'll notice that the pulse width includes the leading-edge transition time and therefore, if you fail to take this into consideration, the generator will issue an error flag.

#### Corrective Actions

- Make sure the delay limits are observed
  - Reduce the delay value
  - Reduce the leading-edge value
  - Reduce the trailing-edge value
- 

### 3.27.5 General Pulse Errors

**General Pulse Errors** Bearing in mind that the pulse is generated mathematically and replayed as an arbitrary waveform, it is very easy to get into tight corners that do not let the generator compute the waveform efficiently. This may come from the following conditions:

Required waveform resolution is  $< 250$  ps

Required memory length  $> 16,000,000$

The computed SCLK  $> 4.2$  GSa/s

System memory allocation limitations

The general pulse errors are hard to define. However, if reasonable parameters range and ratio-to-period are kept, the 81180A should have no problem computing and generating the required pulse shape.

---

## 3.28 Using Markers

### Using Markers

There are two marker outputs available for each channel. The markers are output differentially through rear panel SMB connectors. The purpose of these markers is to be used as auxiliary outputs that are fully synchronous with the output waveforms. Although the markers are part of the waveform data, when used, they do not reduce the number of DAC bits that are available for the arbitrary function.

The markers can be placed anywhere along the waveforms and their width adjusted, sort of adjustable pulse width. Low- and high-voltage controls are also available separately for each marker output, and since the markers are part of the waveform data, jitter between the markers and the output waveform is minimized.

Bench operation of the 81180A allows programming of a single marker transition per channel. However, if you are controlling the product from remote, you can download multiple markers as part of the waveform data and in fact, use the marker terminals to output strings of pulse data.

Note that there is a constant system delay between the output start and the marker outputs, but this can be adjusted to have the same phase using the delay and offset features of the output waveform. The system delay value is given in Appendix A.

The display as shown in *Figure 3-55* will provide access to the marker parameters as soon as you hit the Markers button in the Control group on the left of the instrument. The screen is divided into two sections: Marker 1 and Marker 2. The Markers screen and parameters are described below.



**Figure 3-55: Marker Menu**

**State** – toggles both marker outputs ON and OFF. Programming the markers from the front panel always generates markers from the start edge of the waveform.

### CH1

Press the CH1 soft key button to access parameters that control channel 1 markers. These are: State, Delay, Pos, Width, High and Low. These parameters are explained as follows:

**Delay** – programs the marker delay value. The delay is measured from the waveform start position and is programmable with resolution of 10 ps from 0.00 ns to 3.00 ns.

**Pos** – programs the position of the marker start in reference to the waveform start point. The position is programmed in units of waveform points (or sample clock periods) from 0 to the full length of the waveform, in increments of 4 waveform points. The marker-position value does not affect the marker-delay value and visa versa.



**Width** – programs the width of the marker in units of waveform points. Minimum width is 4 points and maximum is the full wavelength of the waveform. The width is programmed in increments of 4 points. The marker delay and position have no affect on the marker, except the sum of the marker-position value and marker-width value cannot exceed the length of the waveform.

**High** – programs the high level of the marker pulse. The level is valid when terminated into a proper load. The high level is programmable from 0.5 V to 1.25 V.

**Low** – programs the low level of the marker pulse. The level is valid when terminated into a proper load. The low level is programmable from 0 V to 0.8 V.

## CH2

Press the CH2 soft key button to access parameters that control channel 2 markers. These are the same as were described above, for channel 1.

## Apply

As was mentioned above, the marker output data is part of the arbitrary waveform data and therefore, modifying the marker parameters do not change the marker output, until the Apply soft key button has been pressed. Every timing change of the marker output initiates an internal cycle that reads and clears the current position, and then updates the waveform memory with the new marker setting. The process is very quick if small changes are made to the markers, but may be longer if many waveform points need to be read and updated.

## 3.29 Using Store/Recall

**Using Store/Recall** The store and recall functions allow you to save important front panel settings and recall them later, when they are needed for a specific application. If you are using external utilities and control the instrument remotely, then it will be best to store all instrument settings and waveforms on the computer's media. However, if local operation is desired, you may still store settings, but bear in mind that the internal memory is limited on what can be saved. Instrument settings and waveforms can also be stored on a disk-on-key that is connected to a front-panel host USB connector (type 1).

The front-panel store/recall function allows access to 10 memory cells. One or more cells can be used for this operation, but you need to observe the

limitations. The internal memory has a capacity to store a total of 4G of waveform points. However, storage of waveforms larger than 1 million points is rather slow and therefore, if you need to store longer waveforms, these should be stored on the hard-drive of your computer.

Press the Store/Recall button in the Control group on the right side of the instrument. This will cause the display to show the Store/Recall panel, as shown in *Figure 3-56*. There are four soft-key buttons in this display: Store, Recall, List and Update. Information on how to use the keys to store and recall setups on different media options is given below.



**Figure 3-56: Store/Recall Menus**

### 3.29.1 Storing Instrument Setups and Waveforms

#### Storing Instrument Setups and Waveforms

The Store display is shown in *Figure 3-57*. This is the first display you enter after pressing the Store/Recall button in the Control group on the right side of the 81180A. The Store display has three fields that you can program: Target, Memory Cell and Store. The operation of these is described below. Note that the selected memory cell will be updated with the information that is shown on the display only after you hit the Update soft key button.

**Target** – will provide the path to the selected memory target. There are two options: Internal and USB. When you select the Internal option, setups and waveform data will be stored on an internal flash memory. The USB option will route the setups and waveform data to the front panel USB host connector.

**Memory Cell** – use this field to select the active memory cell. There are 9 memory cells that you may access and each of these cells can be used to store

different setups and different waveforms, but you may not store more than one waveform in a specific memory cell location.

**Store** – use this field to select what you want to store. You may select between Setup, Waveform and All. Setup stores the current front panel settings, including parameters, as well as operating and output modes. Waveform will store just waveform segments and All will store both the front panel setting, sequence tables and all waveform segments.



Figure 3-57: Store Menus

Regardless of what you select for each field, the operation will be completed only after you press the Update Soft Key button.

Note that storing waveforms larger than 1 M points to either the internal flash memory or the external USB is rather slow and therefore, expect long delays while storing large waveform banks when using one of these options. It is highly recommended that waveforms above 1 M points be stowed away on a faster media such as a computer hard drive and downloaded to the instrument as required for the test.

### 3.29.2 Recalling Instrument Setups and Waveforms

**Recalling Instrument Setups and Waveforms** The Recall display is shown in *Figure 3-58*. Just like the Store display, the Recall display has three fields that you can program: Target, Memory Cell and Store. The operation of these is described below.

Note that the front panel will be updated with the information that is shown on

the display only after you hit the Update soft key button.

**Target** – will provide the path to the selected memory target. There are two options: Internal and USB. When you select the Internal option, setups and waveform data will be recalled from an internal flash memory. Note that the size of this if case you intend to store large banks of waveform memory. The USB option will route the setups and waveform data from the front-panel USB host- connector. There you may connect a disk-on-key that can store very large waveforms.

**Memory Cell** – use this field to select the active memory cell. There are 10 memory cells that you may access and each of these cells can be used to recall different setup and a different waveform.

**Recall** –this field shows what you are about to recall. The field is grayed-out and does not allow access to the selected option since the contents of the memory cell is programmed in the store menu.

Regardless of what you select for each field, the operation will be completed only after you press the Update Soft Key button.



**Figure 3-58: Recall Menu**

Note that recalling waveforms larger than 1 M points from either the internal flash memory or the external USB is rather slow and therefore, expect long delays while recalling large waveform banks when using one of these options. It is highly recommended that waveforms above 1 M points be stowed away on a faster media such as a computer hard drive and downloaded to the instrument as required for the test.

### 3.29.3 Listing Storage Memory Contents

#### Listing Storage Memory Contents

If you are not sure what is stored in each of the memory cells, you can press the List Soft Key button. The list has no function other than showing what is stored in the memory cells. Press the List Soft Key button and the panel as shown in Figure 3-59 will be displayed. Note that the List display provides access to the storage media. You may select between USB and Internal and the panel will show the parameters that are stored on this specific media.

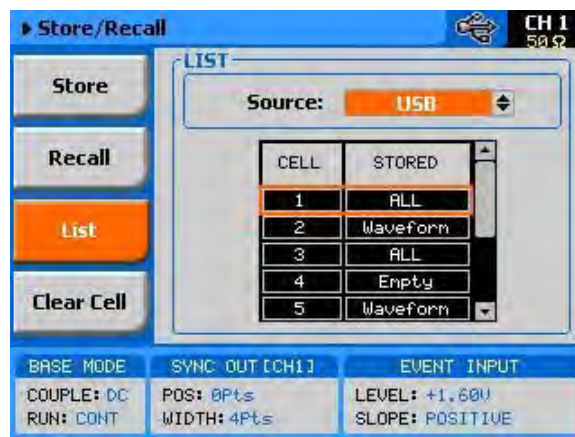

Figure 3-59: Stored Memory Cells Listed

Note that the dialog box can display the contents of five cells only. To see the rest, use the dial or the cursor up and down buttons to navigate to the required cell. To modify the Source media, press the cursor up button till the Source field is selected, press the enter key and again use the cursor up or down key to select the required storage media; then, press Enter again to select and the display will be updated with the contents of the source.

From the List dialog box you may also clear memory cells that you want to discard of. Press the Clear Cell soft key button, using the cursor up and down, or the dial, select the cell number you want to clear and press Enter. In the example above, Cell number 4 has been cleared and shows "Empty" in the stored options.

### 3.29.4 Store/Recall Considerations

#### Store/Recall Considerations

The 81180A is using Linux as its operating system. Although the displays and menus have the feeling of Windows operating system, some of the privileges that are associated with Windows OS are not available in the 81180A. For example, do not expect the same behavior as plugging a stick to a Windows based operating system; There are no messages and no confirmation when a USB has been mounted or removed.

The following are some considerations that you should bear in mind when using the USB stick to store waveforms and setups out of the 81180A.

When plugging a USB stick to the 81180A allow between 5 to 10 seconds for the operating system to mount the device. An attempt to access the stick before it has been mounted generates an error.

When downloading setups and waveforms on a USB stick, the setups and waveforms can be used reliably on another 81180A instrument only if the firmware revision is the same. The reason is because an instrument image is never the same across firmware versions.

Waveform data is stored in a working memory that is extremely fast because it feeds the DAC however, in contrary, the flash memory that is used for storing waveforms is much slower and therefore, when moving large chunks of waveforms from the working memory to the flash memory is a slow process because the data is transferred one word at a time. For this reason, refrain from storing or recalling large waveforms regardless if you use the internal memory or an external USB stick; Keeping your large waveforms on a hard drive is a much faster method to recall waveforms to the working memory.

It is possible to copy files that were stored on a USB stick to a host computer however, before copying files from a computer to another USB stick make sure that the files have names like setup1 and wave1 with no added characters or extensions. Sometimes, Linux adds strange characters to file names but these can be renamed in Windows environment to remove the extra characters.

When powered down, the 81180A can be programmed to power on with its last setup or with all parameters set to the factory defaults. The Power ON State, as shown in Figure 3-1 provides access to this selection. When the Setup option is selected, just before the instrument turns off, it performs an automatic storage to its internal flash memory of its last state, along with the entire bank of waveforms and sequence tables. If you downloaded to the 81180A short waveform segments that have a combined length of less than 1 M should not be a problem however, above 1 M, the storage process may take

long. It is therefore recommended that you avoid using the Setup option in the System menu.

---

### 3.29.5 Store/Recall Messages

#### Store/Recall Messages

Some messages may appear when you perform store and recall operations on the 81180A. These messages are described below. The following messages will appear after performing a successful store or recall operations using the internal flash memory:

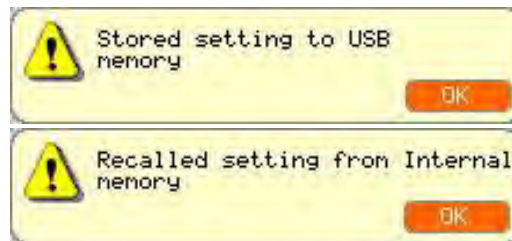

The following messages will appear after performing a successful store or recall operations using the external USB stick:

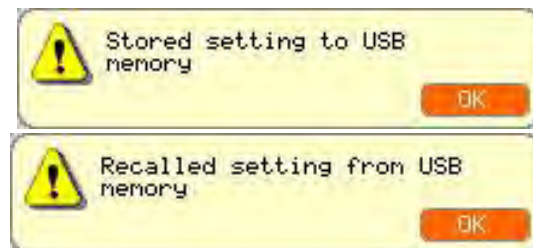

There are also some USB error messages that may appear in case an illegal operation has been performed. A general error such as unrecognized file structure or file contents will generate the following error:



The following error message will display in the event that one attempts to use the external USB stick but has not yet plugged it to the instrument or the device is not yet mounted on the system,



And finally, if you pull the USB out of its socket before the store or recall operation has been fully executed, expect the following message to appear. In most case, recovery from this error is possible only after recycling the 81180A power.





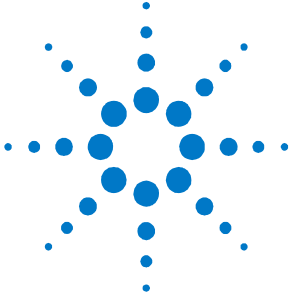

## 4 Programming Reference

### 4.1 What's in this Chapter

**What's in this Chapter** This Chapter lists and describes the set of SCPI-compatible (Standard Commands for Programmable Instruments) remote commands used to operate the Agilent 81180A. To provide familiar formatting for users who have previously used the SCPI reference documentation, the command descriptions are dealt with in a similar manner. In particular, each sub-system's documentation starts with a short description, followed by a table showing the complete set of commands in the sub-system. In conclusion, the effects of individual keywords and parameters are described.

The complete listing of all commands used for programming the Agilent 81180A is given in *Table 4-1*.

---

### 4.2 Introduction to SCPI

**Introduction to SCPI** Commands to program the instrument over the GPIB are defined by the SCPI 1993.0 standard. The SCPI standard classifies a common language protocol. It goes one step further than IEEE-STD-488.2 and defines a standard set of commands to control every programmable aspect of the instrument. It also defines the format of command parameters and the format of values returned by the instrument.

SCPI is an ASCII-based instrument command language designed for test and measurement instruments. SCPI commands are based on a hierarchical structure, known as a tree system. In this system, associated commands are grouped together under a common node or root, consequently forming subsystems.

Part of the OUTPUT subsystem is shown below to illustrate the tree system:

```
:OUTPut
:FILTer
  [:LPASs] {NONE | 25M | 50M | ALL}
  [:STATe] OFF | ON
```

OUTPUT is the root keyword of the command; FILTER and STATE are second level keywords. LPASs is third level keyword.

A colon ( : ) separates a command keyword from a lower level keyword.

---

## 4.3 Command Format

**Command Format** The format used to show commands in this manual is shown below:

```
FREQuency {<frequency> | MINimum | MAXimum}
```

The command syntax shows most commands (and some parameters) as a mixture of upper and lowercase letters. The uppercase letters indicate the abbreviated spelling for the command. For shorter program lines, send the abbreviated form. For better program readability, use the long form.

For example, in the above syntax statement, FREQ and FREQUENCY are both acceptable forms. Use upper or lowercase letters. Therefore, FREQ, FREQUENCY, freq, and Freq are all acceptable. Other forms such as FRE and FREQUEN will generate an error.

The above syntax statement shows the frequency parameter enclosed in triangular brackets. The brackets are not sent with the command string. A value for the frequency parameter (such as "FREQ 50e+6") must be specified. Some parameters are enclosed in square brackets ([ ]). The brackets indicate that the parameter is optional and can be omitted. The brackets are not sent with the command string.

---

## 4.4 Command Separator

**Command Separator** A colon ( : ) is used to separate a command keyword from a lower level keyword as shown below:

```
SOUR:FUNC:SHAP SIN
```

A semicolon (;) is used to separate commands within the same subsystem, and can also minimize typing. For example, sending the following command string:

```
TRIG:SLOP NEG;COUN 10;TIM 5e-3
```

is the same as sending the following three commands:

```
:TRIG:SLOP NEG
:TRIG:COUN 10
:TRIG:TIM 5e-3
```

Use the colon and semicolon to link commands from different subsystems. For example, in the following command string, an error is generated if both the colon and the semicolon are not used.

```
OUTP:STATE ON::TRIG:BURS ON
```

---

## 4.5 The MIN and MAX Parameters

**The MIN and MAX Parameters** Substitute MINimum or MAXimum in place of a parameter for some commands. For example, consider the following command:

```
FREQuency {<frequency>|MINimum|MAXimum}
```

Instead of selecting a specific frequency, substitute MIN to set the frequency to its minimum value or MAX to set the frequency to its maximum value.

---

## 4.6 Querying Parameter Setting

**Querying Parameter Setting** Query the current value of most parameters by adding a question mark ( ? ) to the command. For example, the following command sets the output function to square:

```
SOUR:FUNC:SHAP SQR
```

Query the output function by executing:

```
SOUR:FUNC:SHAP?
```

---

## 4.7 Query Response Format

**Query Response Format** The response to a query depends on the format of the command. In general, a response to a query contains current values or settings of the generator. Commands that set values can be queried for their current value. Commands that set modes of operation can be queried for their current mode. IEEE-STD-488.2 common queries generate responses, which are common to all IEEE-STD-488.2 compatible instruments.

---

## 4.8 SCPI Command Terminator

**SCPI Command Terminator** A command string sent to the function generator must terminate with a <new line> character. The IEEE-STD-488 EOI message is a <new line> character. Command string termination always resets the current SCPI command path to the root level.

---

## 4.9 IEEE-STD-488.2 Common Commands

**IEEE-STD-488.2 Common Commands** The IEEE-STD-488.2 standard defines a set of common commands that perform functions like reset, trigger and status operations. Common commands begin with an asterisk (\*), are four to five characters in length, and may include one or more parameters. The command keyword is separated from the first parameter by a blank space. Use a semicolon ( ; ) to separate multiple commands as shown below:

\*RST; \*STB?; \*IDN?

---

## 4.10 SCPI Parameter Type

**SCPI Parameter Type** The SCPI language defines four different data formats to be used in program messages and response messages: numeric, discrete, Boolean, and arbitrary block.

---

### 4.10.1 Numeric Parameters

**Numeric Parameters** Commands that require numeric parameters will accept all commonly used decimal representations of numbers including optional signs, decimal points, and scientific notation. Special values for numeric parameters like MINimum and MAXimum are also accepted.

Engineering units using numeric parameters (e.g., MHz or kHz) can also be sent. If only specific numeric values are accepted, the function generator will ignore values which are not allowed and will generate an error message. The following command is an example of a command that uses a numeric parameter:

VOLT:AMPL <amplitude>

---

### 4.10.2 Discrete Parameters

**Discrete Parameters** Discrete parameters are used to program settings that have a limited number of values (i.e., FIXed, USER and SEQuence). They have short and long form command keywords. Upper and lowercase letters can be mixed. Query responses always return the short form in all uppercase letters. The following command uses discrete parameters:

```
SOUR:FUNC:MODE {FIXed | USER | SEQuence}
```

---

### 4.10.3 Boolean Parameters

**Boolean Parameters** Boolean parameters represent a single binary condition that is either true or false. The generator accepts "OFF" or "0" for a false condition. The generator accepts "ON" or "1" for a true condition. The instrument always returns "0" or "1" when a boolean setting is queried. The following command uses a boolean parameter:

```
OUTP:FILT { OFF | ON }
```

The same command can also be written as follows:

```
OUTP:FILT {0 | 1 }
```

---

### 4.10.4 Arbitrary Block Parameters

**Arbitrary Block Parameters** Arbitrary block parameters are used for loading waveforms into the generator's memory. Depending on which option is installed, the 81180A can accept binary blocks up to 16 M bytes (64 M bytes with option -264). The following command uses an arbitrary block parameter that is loaded as binary data:

```
TRAC:DATA#564000<binary_block>
```

---

### 4.10.5 Binary Block Parameters

**Binary Block Parameters** Binary block parameters are used for loading segment and sequence tables into the generator's memory. Information on the binary block parameters is given later in this chapter.

---

## 4.11 SCPI Syntax and Styles

### SCPI Syntax and Styles

Where possible, the syntax and styles used in this section follow those defined by the SCPI consortium. The commands on the following pages are broken into three columns; the Keyword, the Parameter Form, Default and HS command equivalent.

The Keyword column provides the name of the command. The actual command consists of one or more keywords, since SCPI commands are based on a hierarchical structure, also known as the tree system. Square brackets ( [ ] ) are used to enclose a keyword that is optional when programming the command. Therefore, the 81180A will process the command to have the same effect whether the optional node is omitted by the programmer, or not. Letter case in tables is used to differentiate between the accepted short form (upper case) and the long form (upper and lower case).

The Parameter Form column indicates the number and order of a parameter in a command and their legal value. Parameter types are distinguished by enclosing the type in angle brackets ( < > ). If parameter form is enclosed by square brackets ( [ ] ) these are then optional (pay attention to be sure that optional parameters are consistent with the intention of the associated keywords). The vertical bar ( | ) can be read as "or" and is used to separate alternative parameter options.

---

## 4.12 81180A Commands

### 81180A Commands

*Table 4-1* lists all of the 81180A SCPI commands. The commands are arranged in logical groups that provide similar functionality, even if they branch from different hierarchy headers, and make it easier to understand the various commands.

The 81180A commands are described in 12 different groups, each describing a different type of operation. The groups are:

Channel and group control commands

Run mode commands

Analog output control commands

Marker output commands

Standard waveforms commands

Arbitrary waveforms commands

Sequenced waveforms commands

Advanced sequencing commands

Modulated waveforms commands

Pulse waveforms commands

LAN configuration commands

System commands

Detailed descriptions of each of the various 81180A commands are given as follows. Note that *Table 4-1* lists all of the commands that control two channels. For a single-channel version, ignore all of the commands that are irrelevant for a single-channel type.

---

**Table 4-1: Model 81180A Commands List Summary**

Keyword	Parameter Form	Default	Notes
<b>1. Channel and Group Control Commands</b>			
:INSTrument			
[:SElect]	CH1   CH2   1   2	CH1	Select channel for prog
:COUPlE			
:OFFSet	0 to n-128 (n = waveform length)	0	Course offset adjustment
:SKEW	-3e-9 to 3e-9	0	Fine skew adjustment
:STATe	OFF   ON   0   1	0	
:XINSTrument			
:MODE	MASTer   SLAVe	MAST	System configuration
:OFFSet	0 to n (n = waveform length)	0	Multi-instrument offset
:STATe	OFF   ON   0   1	0	
<b>2. Run Mode Commands</b>			
:ABORt			Unconditional abort
:ARM			Applies to Event Input
[:SEQUence]			
:ECL			Sets ECL level
:LEVel	-5 to +5	1.6	
:SLOPe	POSitive   NEGative   EITHER	POS	
:TTL			Sets TTL level
:ENABle			Unconditional enable
:INITiate			
:CONTInuous			
:ENABle	SELF   ARMed	SELF	
:SOURce	BUS   EVENT   TRIGger	BUS	Selects enable source
[:STATe]	OFF   ON   0   1	1	
:GATE			
[:STATe]	OFF   ON   0   1	0	
:TRIGger			Applies to trigger input
[:IMMediate]			Same as *trg
[:SEQUence]			
:COUNT	1 to 1,048,575	1	Counted bursts
:DELay	0 to 8e6 (integers divisible by 8)	0	
:ECL			Sets ECL level
:FILTer			
:HPASs			Sets high pass width
:WIDTh	10e-9 to 2	100e-3	
[:STATe]	OFF   ON   0   1	0	
:LPASs			Sets low pass width
:WIDTh	10e-9 to 2	1e-3	
[:STATe]	OFF   ON   0   1	0	



Keyword	Parameter Form	Default	Notes
:HOLDoff	0, 100e-9 to 2	0	0 = Off
[:STATe]	OFF   ON   0   1	0	
:LEVel	-5 to +5	1.6	
:MODE	NORMal   OVERride	NORM	Normal or retriggerable
:SLOPe	POSitive   NEGative   EITHER	POS	
:SOURce			
[:ADVance]	EXTernal   BUS   TIMer   EVENT	EXT	Selects trigger source
:TIMer			
:MODE	TIME   DELay	TIME	
:DELay	152 to 8e6 (integers divisible by 8)	152	Stop to start delay
:TIME	100e-9 to 20	15e-6	
:TTL			Sets TTL level
<b>3. Analog Output Control Commands</b>			
:OUTPut			
:COUPling	DC   DAC   AC	DC	AC selects RF output
[:STATe]	OFF   ON   0   1	0	Toggles output(s) on/off
:SYNC			
:FUNCTion	PULSe   WCOMplete	PULS	Selects sync out shape
:POSition			
[:POINt]	0 to 16e6-32 (0 to 64e6-32 with option -264)	0	Programs sync position
:WIDTh	32 to n-32	32	Sync width (Pulse only)
:SOURce	CH1   CH2   1   2	CH1	Sync source
[:STATe]	OFF   ON   0   1	0	Toggles sync on/off
[:SOURce]			
:FREQuency			
[:CW]	10e3 to 250e6   MINimum   MAXimum	10e6	Std waveforms frequency
:RASTer	10e6 to 4.2e9   MINimum   MAXimum	1e9	Arb waveforms frequency
:SOURce	INTernal   EXTernal	INT	Selects SCLK source
:DIVider	1 to 256 (integers, 2n only)	1	External clock divider
:FUNCTion			
:MODE	FIXed   USER   SEQuence   ASEQuence   MODulation   PULSe	FIX	Selects function type
:POWer			AC coupled (RF) output
[:LEVel]			
[:AMPLitude]	-5 to 5   MINimum   MAXimum	0	AC amplitude in dBm
:ROSCillator			
:SOURce	INTernal   EXTernal	INT	
[:EXTernal]			
:FREQuency	10e6 to 100e6	100e6	
:VOLTage			DC coupled output

Keyword	Parameter Form	Default	Notes
:DAC	50e-3 to 500e-3   MINimum   MAXimum	500e-3	DAC amplitude in volts
[[:LEVel]]			
[[:AMPLitude]]	50e-3 to 2   MINimum   MAXimum	500e-3	DC amplitude in volts
:OFFSet	-1.5 to 1.5   MINimum   MAXimum	0	DC offset in volts
<b>4. Marker Output Commands</b>			
[[:SOURce]]			
:MARKer[1   2]			Selects active marker
:DELay	0 to 3e-9	0	Delay from SYNC
[[:STATe]]	OFF   ON   0   1	0	Toggles marker on/off
:POSition	0 to n-4 (n = segment length)	0	Position from start
:WIDTh	0 to n-4 (n = segment length)	64	Marker width
:VOLTage			
[[:LEVel]]			
:HIGH	0.5 to 1.25	0.5	Marker high level
:LOW	0 to 0.8	0	Marker low level
<b>5. Standard Waveforms Commands</b>			
[[:SOURce]]			Shape and controls
:FUNCTion			
:SHAPe	SINusoid   TRIangle   SQUare   RAMP   SINC   GAUSSian   EXPonential   NOISe   DC	SIN	Standard function shape
:SINusoid			
:PHASe	0 to 360.00	0	
:TRIangle			
:PHASe	0 to 360.00	0	
:SQUare			
:DCYClE	0 to 99.99	50	
:RAMP			
:DELay	0 to 99.99	10	
:TRANsition			
[[:LEADing]]	0 to 99.99	60	
:TRAIling	0 to 99.99	30	
:SINC			
:NCYClE	4 to 100	10	
:GAUSSian			
:EXPonent	1 to 200	10	
:EXPonential			
:EXPonent	-100 to 100	-10	
:DC			DC coupled only
[[:OFFSet]]	-1.5 to 1.5	0	

Keyword	Parameter Form	Default	Notes
<b>6. Arbitrary Waveforms Commands</b>			
:TRACe			
[:DATA]	#<header><binary_block>		Waveform data array
:DEFine	<segment_#>,<320 to 16(64)e6> [<segment_#>,<size>]		Wave name and length
:DELete			
[:NAME]	1 to 32,000		Delete one segment
:ALL			Delete all segments
:POINTs?			Query waveform length
:SELect	1 to 32,000	1	
:SOURce	BUS   EXTERNAL	BUS	Toggle control source
:TIMing	COHerent   IMMEDIATE	COH	Select timing
:SEGMENT			
[:DATA]	#<header><binary_block>		Segment data array
<b>7. Sequenced Waveforms Commands</b>			
[:SOURce]			
:SEQuence			
:ADVance	AUTOmatic   ONCE   STEPped	AUTO	
[:DATA]	#<header><data_array>		
:DEFine	<step>,<segment_#>,<loops>,<jump_flag>		
:DELete			
[:NAME]	1 to 1,000		
:ALL			
:JUMP			
[:EVENT]	BUS   EVENT	BUS	Toggle jump source
:LENGth	3 to 32,768		Optional definition
:SELect	1 to 1,000		
:SOURce	BUS   EXTERNAL	BUS	Toggle control source
:TIMing	COHerent   IMMEDIATE	COH	Jump timing
:PREStep	WAVE   DC	WAVE	Active in conjunction with continuous and BUS source only
:ONCe			
:COUNt	1 to 1,048,575		
:SYNC			
:LOCK	<step_number>	1	Sync position
<b>8. Advanced Sequencing Commands</b>			
[:SOURce]			
:ASEQuence			
:ADVance	AUTOmatic   ONCE   STEPped	AUTO	
:DEFine	<step>,<sequence_#>,<loops>,<jump_flag>		
:DELete			Deletes table

:LENGth	1 to 1,000		Optional definition
:ONCe			
:COUNt	1 to 1,048,575		
:SYNC			
:LOCK	1 to 1,000	1	Sync position
<b>Keyword</b>	<b>Parameter Form</b>	<b>Default</b>	<b>Notes</b>
<b>9. Modulated Waveforms Commands</b>			
[:SOURce]			
:MODulation			
:TYPE	OFF   AM   FM   SWEep	OFF	
:CARRier			
[:FREQuency]	10e3 to 250e6	1e6	
:FUNction	SINusoid   TRlangle   SQUare	SIN	
:AM			
:FUNction			
:SHAPe	SINusoid   TRlangle   SQUare   RAMP	SIN	
:INTernal			
:FREQuency	100 to 1e6	1e3	Maximum Carrier to internal freq ration is 1e6
:DEPTH	0 to 100	50	
:FM			
:DEVIation	10e-3 to 100e6	100e3	
:FUNction			
:SHAPe	SINusoid   TRlangle   SQUare   RAMP	SIN	
:FREQuency	10e-3 to 350e3	10e3	
:MARKer			
[:FREQuency]	10e3 to 250e6	505e3	
:SWEep			
:FREQuency			
[:STARt]	10e3 to 250.0e6	10e3	
:STOP	10e3 to 250e6	1e6	
:TIME	1.4e-6 to 40.0	1e-3	
:DIRection	UP   DOWN	UP	
:SPACing	LINear   LOGarithmic	LIN	
:MARKer			
[:FREQuency]	10e3 to 250e6	505e3	
<b>10. Pulse Waveform Commands</b>			
:PULSe			
:CONFigure	TIME   PERCent	TIME	
:DELay	0, 1e-9 to 1s	0	Delay in sec
:PERCent	0.01 to 99.99	10	Delay in %

:DOUBLE			
:DELay	1e-9 to 1s	1e-3	Double delay in sec
:PERCent	0.01 to 99.99	10	Delay in %
:LEVel			
[:CONTRol]	HLOW   AOFFset   POSitive   NEGative	HLOW	
<b>Keyword</b>	<b>Parameter Form</b>	<b>Default</b>	<b>Notes</b>
:HIGH	-2.450 to 2.5	1	
:LOW	-2.5 to 2.450	0	
:AMPLitude	50e-3 to 2   MINimum   MAXimum	0.5	Amplitude in V
:OFFSet	-1.5 to 1.5   MINimum   MAXimum	0	DC offset in volts
:MODE	SINGle   DELayed   DOUBle	SING	
:POLarity	NORMal   COMPLEMENT   INVERTed	NORM	
:PERiod	80e-9 to 1e6 (80e-9 to 2e6 with option -264)	10e-3	
:TRANsition			
[:STATe]	FAST   LINear   SYMMetrical	FAST	Transition mode
[:LEADing]	1e-9 to 100e-3	1e-3	Rise time in sec
:PERCent	0.01 to 99.99	10	Rise time in %
:TRAIling	1e-9 to 100e-3	1e-3	Fall time in sec
:PERCent	0.01 to 99.99	10	Fall time in %
:WIDTh	1e-9 to 1s	2e-3	Width in sec
:PERCent	0.01 to 99.99	20	Width in %
<b>11. LAN Configuration Commands</b>			
:SYSTem			
:IP			
[:ADDRes]	<IP_address>		
:MAsK	<mask>		
:GATeway	<gate_way>		
:BOOTp	OFF   ON   0   1	0	
HOSTname:	<host_name>		
:KEEPalive			
:STATe	OFF   ON   0   1	1	
:TIMEout	2 to 300	45	
:PROBES	2 to 10	2	
<b>12. Store/Recall Commands</b>			
:SYSTem			
:STORe			
:CELL	1 to 9		
:CLEAr			Clears memory cell
:CONFig	SETup   WAVE   ALL	ALL	
:TARGet	INTernal   USB	INT	
:UPDate			
:RECall			

:CELL	1 to 9		
:TARGet	INTernal   USB	INT	
:UPDate			
<b>Keyword</b>	<b>Parameter Form</b>	<b>Default</b>	<b>Notes</b>
<b>13. System Commands</b>			
:RESet			
:SYSTem			
:ERRor?			
:LOCal			
:VERSion?			
:INFormation			
:CALibration?			
:MODEl?			
:SERial?			
:HARDware?			
:POWeup	DEFault   SETup	DEF	
<b>14. Common Commands</b>			
*RST			Reset to factory defaults
*TRG			Trigger
*OPC?			Query operation complete
*STB?			Query instrument status byte
*IDN?			Query instrument identity
*OPT?			Query instrument option, returns 116 for 1 ch, 16M; 216 for 2 ch, 16M; 264 for 2 ch, 64M

### 4.12.1 Channel & Group Control Commands

#### Channel & Group Control Commands

Commands that are listed in *Table 4-2* control parameters that group and synchronize two or more channels, as well as their relative offset and skew parameters. Factory defaults after \*RST are shown in the Default column. Parameter range and low and high limits are listed, where applicable.

Note the command *inst ch1 / ch2*. The default parameter is *ch1*, which means that commands that are sent to the 81180A affect channel 1 settings only. Select the *inst ch2* parameter if you want to program channel 2 parameters.



The Model **81180A-116** has only one output channel and therefore, the command *inst:sel* is not required for correct programming sequences however, for the Model **81180A-264**, it is mandatory to select the proper channel before commands are being streamed to the product. The 81180A-264 has two completely separate channels and therefore, each of the commands that are listed in the following tables should be preceded by the *inst:sel 1* or *inst:sel 2* commands.

There are some commands that affect both channels simultaneously and do not require that a specific channel is selected; these are LAN configuration commands, Store/recall commands, System Commands and common commands.

Note that the two channels can operate in synchronized mode where both channels share the same output waveform type, the same run mode option and a common sample clock feed. In this case, the sample clock value should be programmed for channel 1 only but the other commands still require the use of *inst:sel* command.

**Table 4-2: Channel & Group Control Commands Summary**

Keyword	Parameter Form	Default	Notes
:INSTrument			
[:SElect]	CH1   CH2   1   2	CH1	Select channel for prog
:COUple			
:OFFSet	0 to n-128 (n = waveform length)	0	Course offset adjustment
:SKEW	-3e-9 to 3e-9	0	Fine skew adjustment
:STATe	OFF   ON   0   1	0	
:XINSTrument			
:MODE	MASTer   SLAVe	MAST	System configuration
:OFFSet	0 to n (n = waveform length)	0	Multi-instrument offset
:STATe	OFF   ON   0   1	0	

### **:INSTrument{ CH1 | CH2 | 1 | 2}(?)**

#### **Description**

This command will set the active channel for future programming command sequences. Subsequent commands affect the selected channel only.

#### **Parameters**

<b>Range</b>	<b>Type</b>	<b>Default</b>	<b>Description</b>
CH1-CH2 or 1-2	Discrete	1	Sets the active channel for programming from remote.

#### **Response**

The 81180A will return 1 or 2 depending on the present active channel setting.

### **:INSTrument:COUPlE:OFFSet{<ch\_offset>}(?)**

#### **Description**

When couple state is ON, this command sets or queries the offset between the start phase of the master channel (CH1) and the start phase of the slave channel (CH2).

#### **Parameters**

<b>Name</b>	<b>Range</b>	<b>Type</b>	<b>Default</b>	<b>Description</b>
<ch_of0 fset>	to n-128	Numeric (integer only)	0	Defines a coarse phase offset between two channels. When offset is applied to one channel it is always in reference to the other channel. For example, offsetting channel 2 by 1024 points and then offsetting channel 1 by 2048 points will cause channel 2 waveform to lag channel 1 by 1024 points. Offset can be programmed in increments of 8 sample clock periods. The two channels must have the same waveform length in order for the phase offset parameter to be meaningful. Offset range is programmable in units of waveform points from 0 to the maximum length of the channel waveform, less 128 waveform points. Fine adjustment of phase offset between channels is achieved using the inst:coup:skew command. Note that this parameter is operating in conjunction with the continuous run mode and only when the two channels are synchronized.

#### **Response**

The 81180A will return the present value of the coarse offset setting in units of waveform points.



**:INSTrument:COUPlE:SKEW{<ch\_skew>}(?)****Description**

When couple state is ON, this command sets or queries the skew between the two channels. Skew defines fine offset between channels in units of time. Only channel 2 has the skew is computed in reference to channel 1. The inst:coupl:skew command is applied automatically to channel 2 and does not require that you use the inst:sel 2 command.

**Parameters**

Name	Range	Type	Default	Description
<ch_s kew>	-3e-9 to 3e-9	Numeric	0	Defines channel 2 skew in reference to channel 1. The two channels must have the same waveform length in order for the phase skew parameter to be meaningful. The skew range is programmable in units of seconds throughout the range of $\pm 3$ ns. Coarse adjustment of phase offset between channels is achieved using the inst:coup:offs command. Note that this parameter is operating in conjunction with the continuous run mode and only when two or more channels are synchronized.

**Response**

The 81180A will return the present value of the skew setting in units of seconds.

**:INSTrument:COUPlE:STATe{OFF | ON | 0 | 1}(?)****Description**

Sets or queries the couple state of the synchronized channels. Use this command to cause the two channels to synchronize.

Following this command, the sample clock of channel 1 will feed the channel 2 and the start phase of the channel 2 channels will lock to the channel 1 waveform.

**Parameters**

Range	Type	Default	Description
0-1	Discrete	0	Sets the couple mode on and off

**Response**

The 81180A will return 1 if the couple state is ON, or 0 if the couple state is OFF.

**:XINStrument:MODE{MASTer | SLAVE}****Description**

Use this command to define master and slave instruments. This command affects the system only when two instruments are hooked to a LAN network, synchronization cable is attached to the rear panel of both instruments and are intended to operate in synchronized mode.

**Parameters**

Name	Type	Default	Description
<MASTer>	String	MAST	Defines the active instrument as the controlling master in a two-instrument system. Only channel 1

<SLAVe>	String	in each instrument can be defined as master; the rest of the channels are defined as slaves. Defines the active instrument as a slave in a two-instrument system.
---------	--------	---

**Response**

The 81180A will return MAST or SLAV depending on the present mode setting.

**:XINstrument:OFFSet{<instrument\_offset>}(?)**

**Description**

When couple state is ON, this command sets or queries the offset between the start phase of the slave instrument in reference to the master channel.

**Parameters**

Name	Range	Type	Default	Description
<instru ment_of fset>	0 to n	Numeric (integer only)	0	Defines a coarse phase offset between two instruments. When offset is applied to one instrument it is always in reference to the other instrument. For example, offsetting the slave instrument by 1024 points and then offsetting master instrument by 2048 points will cause slave waveform to lag the master waveform by 1024 points. Offset can be programmed in increments of 8 sample clock periods.

**Response**

The 81180A will return the present value of the coarse offset setting in units of waveform points (SCLK periods).

**:XINSTRument: STATe{OFF|ON|0|1}(?)**

**Description**

Sets or queries the couple state of the synchronized instruments. Use this command to synchronize two instruments to a single sample clock reference. This command can be used only after defining one instrument as master (xins:mode mast) and the other as slave (xins:mode slav). Use the xins:stat 1 on the master instrument only. The reference sample clock is generated by the master instrument

**Parameters**

Range	Type	Default	Description
0-1	Discrete	0	Sets the two-instruments couple on and off

**Response**

The 81180A will return 1 if the couple is ON, or 0 if the couple is OFF.

## 4.12.2 Run Mode Commands

**Run Mode Commands** The Run Mode Commands group is used to synchronize device actions with external or internal events.  
The 81180A can operate in two basic modes: self-armed and armed-for - enable.

Self-armed mode is the default option where waveforms are generated at the output connector, immediately after the output function has been selected.

In armed mode, the 81180A requires an enable command or an external analog event to cause the output to generate waveforms and when already armed, a remote abort command will cease the generation of the signal and the output will return to a known idle state. This mode is very useful to control how and when the waveform will start and stop for systems that require precise control of waveform timing.

Other commands in this group control the basic run modes of the waveform generator. The available run modes are:

continuous, where waveforms are generated continuously at the output connector and triggered and gated.

conditional, where waveforms are generated on conditional events, regardless if they are generated internally from a built-in trigger generator or applied externally to the trigger and event inputs.

Also use the commands in this group to control the sensitivity, the polarity and other conditions of which external signals will affect the trigger and event inputs.

A built-in counter is available to control a precise number of cycles for applications requiring a burst of waveforms that follows a trigger event. Additional information on the run mode options and how the generator behaves under the various run mode options is given in Chapter 3. Factory defaults after \*RST are shown in the default column. Parameter low and high limits are given where applicable. Use the commands in *Table 4-3* to set up the 81180A run mode and for setting up the input conditions for the various trigger inputs.

---

Table 4-3: Run Mode Commands Summary

Keyword	Parameter Form	Default	Notes
:ABORt			Unconditional abort
:ARM			Applies to Event Input
[:SEQuence]			
:ECL			Sets ECL level
:LEVel	-5 to +5	1.6	
:SLOPe	POSitive   NEGative   EITHer	POS	
:TTL			Sets TTL threshold level
:ENABle			Unconditional enable
:INITiate			
:CONTInuous			
:ENABle	SELF   ARMed	SELF	
:SOURce	BUS   EVENt   TRIGger	BUS	Selects enable source
[:STATe]	OFF   ON   0   1	1	
:GATE			
[:STATe]	OFF   ON   0   1	0	
:TRIGger			Applies to trigger input
[:IMMEDIATE]			Same as *trg
[:SEQuence]			
:COUNt	1 to 1,048,576	1	Counted bursts
:DELay	0 to 8e6 (integer divisible by 8)	0	0 = OFF
:ECL			Sets ECL level
:FILTer			
:HPASs			Sets high pass width
:WIDTh	10e-9 to 2	100e-3	
[:STATe]	OFF   ON   0   1	0	
:LPASs			Sets low pass width
:WIDTh	10e-9 to 2	1e-3	
[:STATe]	OFF   ON   0   1	0	
:HOLDoff	0, 100e-9 to 2	0	0 = Off
[:STATe]	OFF   ON   0   1	0	
:LEVel	-5 to +5	1.6	
:MODE	NORMAl   OVerride	NORM	Normal or retriggerable
:SLOPe	POSitive   NEGative   EITHer	POS	
:SOURce			
[:ADVance]	EXTernal   BUS   TIMer   EVENt	EXT	Selects trigger source
:TIMer			
:MODE	TIME   DELay	TIME	
:DELay	152 to 8e6 (integers divisible by 8)	152	Stop to start delay
:TIME	100e-9 to 20	15e-6	
:TTL			Sets TTL level

**:ABORt****Description**

Use this command for an immediate and unconditional termination of the output waveform. A prerequisite condition that makes this command effective is to place the 81180A in continuous and armed run mode and then enable the output using the enab command. This command is also effective in all triggered run mode options. Following the abort command, the 81180A stops generating waveforms and the output starts generating an idle waveform that could be one of: dc, first waveform in a sequence or first sequence in an advanced sequence scheme. The abort command ignores the trac:sel:tim and the sequ:sel:tim settings. The resulting scenarios of the abort command are summarized in the Run Modes Summary table in Chapter 3.

**:ARM:ECL****Description**

Use this command to set the event input to accept ecl (negative) signals. The threshold level is automatically set to -1.3 V, which is the mid-level for negative ecl logic. Other related commands are: arm:tll to set the threshold level for TTL signals and arm:lev to program a threshold level between -5 V to 5 V. Note that commands that start with ARM affect the conditions for the event input only.

**:ARM:LEVel<level>(?)****Description**

This command programs the threshold level for the event input signals. Other related commands are: arm:tll to set the threshold level for TTL signals and arm:ecl to program a threshold level for ECL signals. Note that commands that start with ARM affect the conditions for the event input only.

**Parameters**

Name	Range	Type	Default	Description
<level>	-5 to 5	Numeric	1.6	Programs the threshold level for the invent input.

**Response**

The 81180A will return the present threshold level setting in units of volts.

**:ARM:SLOPe{POSitive | NEGative | EITHer}(?)****Description**

Use this command to define the edge that will affect the event input. Positive going transitions will affect the event input when the POS option is selected. Negative transitions will affect the event input when the NEG option is selected. Both transitions will affect the event input when the EITH option is selected. Note that commands that start with ARM affect the conditions for the event input only.

**Parameters**

Name	Type	Default	Description
POSitive	Discrete	POS	Selects the positive going edge.
NEGative	Discrete		Selects the negative going edge.
EITHer	Discrete		Selects both positive and negative going edges.

## Response

The 81180A will return POS, NEG, or EITH depending on the current slope setting.

## :ARM:TTL

### Description

Use this command to set the event input to accept ttl signals. The threshold level is automatically set to 1.6 V, which is the mid-level for ttl logic. Other related commands are: arm:ecl to set the threshold level for ECL signals and arm:lev to program a threshold level between -5 V to 5 V. Note that commands that start with ARM affect the conditions for the event input only.

## :ENABLE

### Description

Use this command for an immediate and unconditional generation of the selected output waveform. Prerequisite condition that makes this command effective is to place the 81180A in continuous and armed run mode. This command has no effect in triggered run mode options. Generation of the output waveform can be terminated abruptly using the abor command. Following the abort command, the 81180A stops generating waveforms and the output starts generating an idle waveform that could be one of: dc, first waveform in a sequence or first sequence in an advanced sequence scheme. The resulting scenarios of the enable and abort commands are summarized in the Run Modes Summary table in Chapter 3.

## :INITiate:CONTInuous:ENABLE{SELF|ARMed}(?)

### Description

Use this command to set or query the state of the enable mode. This command is effective in continuous mode only and has no effect when the init:cont 0 or init:gate 1 (triggered or gated modes) were executed.

### Parameters

Name	Type	Default	Description
SELF	Discrete	SELF	In continuous run mode, waveforms are generated at the output connector as soon as they are selected.
ARMed	Discrete		The 81180A generates waveforms at the output connector only after an enab command is executed. For an immediate and unconditional termination of the output waveform use the abor command.

## Response

The 81180A will return SELF, or ARM depending on the current enable mode setting.

**:INITiate:CONTinuous{1 | 0 | ON | OFF}{?}**

Use this command to set or query the gated run mode status.

**Parameters**

Range	Type	Default	Description
1-0	Discrete	1	“1” selects the continuous run mode. “0” disables the continuous operation and forces the triggered run mode. Trigger signal is applied to the trigger input only and output waveforms will be generated only when the trigger signal is valid and true. The slope and level of the trigger input are programmable.

**Response**

The 81180A will return 1 or 0 depending on the current run mode setting.

**:INITiate:CONTinuous:ENABLE:SOURce{BUS | EVENT | TRIGger}{?}****Description**

Use this command to set or query the source of the enable signal. This command is effective in continuous mode only and has no effect when the init:cont 0 or init:gate 1 (triggered or gated modes) were executed.

**Parameters**

Name	Type	Default	Description
BUS	Discrete	BUS	Defines the source of the enable signal as a remote command sent over one of the interfacing controllers (USB, LAN or GPIB). Signals at the event input will be ignored. In continuous run mode, waveforms are generated at the output connector as soon as a remote enable command is executed. For an immediate and unconditional termination of the output waveform use the abor command.
EVENT	Discrete		Defines the source of the enable signal as the event input connector. Remote enable commands will be ignored. In continuous run mode, waveforms are generated at the output connector as soon as a valid event signal is sensed at the event input connector. For an immediate and unconditional termination of the output waveform use the abor command.
TRIGger	Discrete		Defines the source of the enable signal as the front panel trigger input connector. Remote enable commands will be ignored. In continuous run mode, waveforms are generated at the output connector as soon as a valid event signal is sensed at the event input connector. For an immediate and unconditional

termination of the output waveform use the abor command.

### Response

The 81180A will return BUS, EVEN, or TRIG depending on the current enable source setting.

### **:INITiate:GATE{0|1|OFF|ON}(?)**

#### **Description**

Use this command to set or query the gated run mode status.

#### **Parameters**

<b>Range</b>	<b>Type</b>	<b>Default</b>	<b>Description</b>
0-1	Discrete	0	"0" forces the continuous run mode. "1" selects the gated run mode. Gating signal is applied to the trigger input only and output waveforms will be generated only when the gate signal is valid and true. The slope and level of the gating entry are programmable.

### Response

The 81180A will return 1 or 0 ,depending on the current run mode setting.

### **:TRIGger**

#### **Description**

Use this command to trigger the 81180A from a remote computer. You may also use the common command \*trg that will have the same effect. This command will affect the 81180A only after you program the instrument to operate in triggered run mode (init:cont 0) and select the trigger source BUS option. Note that commands that start with TRIG affect the conditions for the trigger input only.

### **:TRIGger:COUNT<burst>(?)**

#### **Description**

Use this command to set or query the burst counter setting. This command is effective only when the 81180A is programmed to operate in triggered run mode (init:cont 0).

#### **Parameters**

<b>Name</b>	<b>Range</b>	<b>Type</b>	<b>Default</b>	<b>Description</b>
<burst>	1 to 1,048,576	Numeric (integer only)	1	Programs the burst count. Following a valid trigger signal, the 81180A generates a pre-programmed number of waveform cycles and then resumes an idle state. The counted burst can be initiated using one of the following: front panel MANUAL push button, remote command such as *trg, or a transition at the trigger input connector.



**Response**

The 81180A will return the present burst count value.

**:TRIGger:DElay<interval>(?)****Description**

Use this command to set or query the trigger delay setting. The trigger delay parameter defines the interval that will elapse from a valid trigger signal to the initiation of the first output waveform. Trigger delay is turned off using the `trig:del 0` command. The trigger delay command affects the generator only after it has been programmed to operate in triggered run mode. Modify the 81180A to triggered run mode using the `init:cont 0` command. The delay interval is programmed in sample clock period increments.

**Parameters**

Name	Range	Type	Default	Description
	<inter0 to 8e6 val>	Numeric (integer only)	0	"0" turns OFF the delayed trigger function. Delay is programmed in sample clock period increments, so expect the delay time to change if you modify your sample clock setting. Program the delay interval using integer numbers divisible by 8 only.

**Response**

The 81180A will return the present trigger delay interval value.

**:TRIGger:ECL****Description**

Use this command to set the trigger input to accept ecl (negative) signals. The threshold level is automatically set to -1.3 V, which is the mid-level for negative ecl logic. Other related commands are: `trig:ttl` to set the threshold level for TTL signals and `trig:lev` to program a threshold level between -5 V to 5 V.

**:TRIGger:FILTer:HPASs:WIDTh<width>(?)****Description**

Use this command to set or query the trigger high pass filter value. Trigger signal having pulse width below the programmed settings will not trigger the generator. The trigger filter has three options: high pass filter, which will trigger the 81180A only if the width is larger than the programmed value, low pass filter, which will trigger the generator only if the width is smaller than the programmed value, and window pass filter, which will trigger the generator only if the width is within a certain range specified by the high and low pass filters.

The `trig:fil:hpas:wid` command sets a high pass threshold for the trigger signal and the `trig:fil:lpas:wid` command sets a low pass threshold for the trigger signal. If both the high and low pass filters are turned on, signals having a pulse width smaller than the low pass setting and larger than the high pass setting will trigger the generator.

### Parameters

Name	Range	Type	Default	Description
	<time 10e-9 to 2 >	Numeric	1e-3	Programs the high pass pulse width value in units of second.

### Response

The 81180A will return the present high pass value in units of seconds.

### :TRIGger:FILter:HPASs{OFF | ON | 0 | 1}(?)

#### Description

Use this command to set or query the status of the high pass filter.

Range	Type	Default	Description
0-1	Discrete	0	Turns the high pass filter on and off.

### Response

The 81180A will return 0, or 1 depending on the present high pass filter state.

### :TRIGger:FILter:LPASs:WIDTh<width>(?)

#### Description

Use this command to set or query the trigger low pass filter value. Trigger signal having pulse width above the programmed setting will not trigger the generator. The trigger filter has three options: high pass filter, which will let trigger the 81180A only if the width is larger than the programmed value, low pass filter, which will trigger the generator only if the width is smaller than the programmed value, and window pass filter, which will trigger the generator only if the width is within a certain range specified by the high and low pass filters.

The trig:fil:hpas:wid command sets a high pass threshold for the trigger signal and the trig:fil:lpas:wid command sets a low pass threshold for the trigger signal. If both the high and low pass filters are turned on, signals having pulse width smaller than the low pass setting and larger than the high pass setting will trigger the generator.

### Parameters

Name	Range	Type	Default	Description
	<time 10e-9 to 2 >	Numeric	1e-3	Programs the high pass pulse width value in units of seconds.

### Response

The 81180A will return the present high pass value in units of seconds.

### :TRIGger:FILter:LPASs{OFF | ON | 0 | 1}(?)

#### Description

Use this command to set or query the status of the low pass filter.

Range	Type	Default	Description
0-1	Discrete	0	Turns the low pass filter on and off.

**Response**

The 81180A will return 0 or 1 depending on the current low pass filter state.

**:TRIGger:HOLDoff<holdoff>(?)****Description**

Use this command to set or query the trigger holdoff period. The trigger holdoff filter defines a period that starts with the first valid trigger input and ends with the holdoff setting of which all triggers within this range, valid or not, are ignored, but the first valid signal after the holdoff range will cause the 81180A to generate a waveform.

**Parameters**

Name	Range	Type	Default	Description
<time>	0, 100e-9 to 2	Numeric	100e-3	Programs the trigger holdoff period in units of second.

**Response**

The 81180A will return the present holdoff value in units of second.

**:TRIGger:HOLDoff{OFF|ON|0|1}(?)****Description**

Use this command to set or query the status of the holdoff filter.

Range	Type	Default	Description
0-1	Discrete	0	Turns the holdoff filter on and off.

**Response**

The 81180A will return 0 or 1 depending on the present holdoff filter state.

**:TRIGger:LEVel<level>(?)****Description**

Use this command to program or query the threshold level for the trigger input signals. Other related commands are: trig:tll to set the threshold level for TTL signals and trig:ecl to program a threshold level for ECL signals. Note that commands that start with trig affect the conditions for the trigger input only.

**Parameters**

Name	Range	Type	Default	Description
<level>	-5 to 5	Numeric	1.6	Programs the threshold level for the trigger input.

**Response**

The 81180A will return the present threshold level setting in units of volts.

**:TRIGger:MODE{NORMal|OVerride}(?)****Description**

Use this command to define or query the trigger mode. In normal mode, the first trigger activates the output and consecutive triggers are ignored for the duration of the output waveform.

In override mode, the first trigger activates the output and consecutive triggers restart the output waveform, regardless if the current waveform has been completed or not.

**Parameters**

Name	Type	Default	Description
NORMal	Discrete	NORM	Selects the normal trigger mode.
OVERride	Discrete		Selects the override trigger mode.

**Response**

The 81180A will return NORM or OVER, depending on the current trigger mode setting.

**:TRIGger:SLOPe{POSitive | NEGative | EITher}(?)**

**Description**

Use this command to define or query the edge that will affect the trigger input. Positive going transitions will affect the trigger input when the POS option is selected. Negative transitions will affect the trigger input when the NEG option is selected and both positive and negative transitions will affect the trigger input when the EIT option is selected. Note that commands that start with ARM affect the conditions for the event input only.

**Parameters**

Name	Type	Default	Description
POSitive	Discrete	POS	Selects the positive going edge.
NEGative	Discrete		Selects the negative going edge.
EITher	Discrete		Selects both positive and negative going edges.

**Response**

The 81180A will return POS, NEG, or EIT depending on the current slope setting.

**:TRIGger:SOURce:ADVance{EXTernal | BUS | TIMer | EVENT}(?)**

**Description**

Use this command to set or query the source of the trigger event that will stimulate the 81180A to generate waveforms.

The source advance command will affect the generator only after it has been programmed to operate in trigger run mode. Modify the 81180A to trigger run mode using the init:cont off command.

**Parameters**

Name	Type	Default	Description
EXTernal	Discrete	EXT	Selects the TRIG IN connector as the input source. The front panel MANUAL can be used in case external triggers are not available. All other inputs are ignored.
BUS	Discrete		Selects the remote controller as the trigger source. Only software commands are accepted; TRIG IN, Event IN and manual triggers are ignored.

TIMer	Discrete	Activates the built in internal trigger generator. BUS and external trigger are ignored. The period of the internal trigger is programmable and can be used to replace an external trigger source.
EVENT	Discrete	Selects the Event IN connector as the input source. All other inputs are ignored.

**Response**

The 81180A will return EXT, BUS, TIM, or EVEN depending on the selected trigger source advance setting.

**:TRIGger:TIMer:MODE{TIME | DELay}(?)****Description**

Use this command to set or query the mode that the internal trigger generator will operate. Timed defines start-to-start triggers and Delayed defines end-to-start triggers. The timer commands will affect the generator only after it has been programmed to operate in timer mode. Modify the 81180A to trigger run mode using the init:cont off command and program the internal timer using the trig:tim command.

**Parameters**

Name	Type	Default	Description
TIME	Discrete	TIME	Selects the timed internal trigger generator. The generator will automatically issue periodical triggers that stimulate the output to generate single cycle waveforms. The periods are programmed in units of seconds from waveform start to waveform start.
DELay	Discrete		Selects the delayed internal trigger generator. The generator will automatically issue periodical triggers that stimulate the output, to generate single cycle waveforms. The periods are programmed in units of waveform points from waveform end to waveform start.

**Response**

The 81180A will return TIME or DEL depending on the selected internal trigger timer mode setting.

**:TRIGger:TIMer:DELay<timer>(?)****Description**

Use this command to set or query the delay setting of the internal delayed trigger generator. This value is associated with the internal trigger run mode only and has no affect on other trigger modes. The internal delayed trigger generator is a free-running oscillator, asynchronous with the frequency of the output waveform. The timer intervals are measured from waveform stop to waveform start.

### Parameters

Name	Range	Type	Default	Description
<time	152 to 8e6	Numeric	152	Programs the internal delayed trigger generator period in units of waveform points. Program the value using integers divisible by 8.

### Response

The 81180A will return the present internal delayed trigger period value in units of waveform points.

### :TRIGger:TIMer:TIME<timer>(?)

#### Description

Use this command to set or query the period of the internal timed trigger generator. This value is associated with the internal trigger run mode only and has no affect on other trigger modes. The internal trigger generator is a free-running oscillator, asynchronous with the frequency of the output waveform. The timer intervals are measured from waveform start to waveform start.

#### Parameters

Name	Range	Type	Default	Description
<time	100e-9 to 20	Numeric	15e-6	Programs the internal timed trigger generator period in units of seconds.

### Response

The 81180A will return the present internal timed trigger period value in units of seconds.

### :TRIGger:TTL

#### Description

Use this command to set the trigegr input to accept ttl signals. The threshold level is automatically set to 1.6 V, which is the mid-level for ttl logic. Other related commands are: trig:ecl to set the threshold level for ECL signals and trig:lev to program a threshold level between -5 V to 5 V.

## 4.12.3 Analog Output Control Commands

**Analog Output Control Commands** The Analog Output Control Commands group is used for programming the characteristics of the output waveform. Notice that there are two main subsystems that control output functions: OUTPut and SOURce. The output subsystem commands control parameters that are related directly to the output terminals (main and sync outputs) and the source subsystem commands program parameters that control waveform shape, frequency and level.

The 81180A has three output options: DC, DAC and AC. Although the titles hint about adding or removing a dc blocking capacitor at the output path, in fact, the 81180A has three completely separate amplifier passages: two are dc

coupled and one is ac coupled. There is also major difference how the outputs behave in time and frequency domains. The (direct) DAC output is optimized for highest bandwidth, but offers low amplitude signals. The DC is optimized for best pulse response at higher amplitude levels, but at the cost of reduced bandwidth. The AC path is mainly used for RF applications where output bandwidth and flatness are optimized, but the control of dc offset bias is not available.

Other commands in this group control the SYNC parameters: type, position and width. Also use the commands in this group to control the shape of the output waveform, its frequency, its output level (or power) and the source of the clock reference.

Additional information on the various output functions and how the generator generates the different waveforms is given in Chapter 3. Factory defaults after \*RST are shown in the default column. Parameter low and high limits are given where applicable. Use the commands in *Table 4-4* to set up the 81180A output waveforms, and their associated characteristics.

---

**Table 4-4: Run Mode Commands Summary**

Keyword	Parameter Form	Default	Notes
:OUTPut			
:COUPling	DC   DAC   AC	DC	AC selects RF output
[:STATe]	OFF   ON   0   1	0	Toggles output(s) on/off
:SYNC			
:FUNction	PULSe   WCOMplete	PULS	Selects sync out shape
:POSition			
[:POINT]	0 to 16e6-32 (0 to 64e6-32 with option -264)	0	Programs sync position
:WIDTh	32 to n-32	32	Sync width (Pulse only)
:SOURce	CH1   CH2   1   2	CH1	Sync source
[:STATe]	OFF   ON   0   1	0	Toggles sync on/off
[:SOURce]			
:FREQuency			
[:CW]	10e3 to 250e6   MINimum   MAXimum	10e6	Std waveforms frequency
:RASTer	10e6 to 4.2e9   MINimum   MAXimum	1e9	Arb waveforms frequency
:SOURce	INTernal   EXTernal	INT	Selects SCLK source
:DIVider	1 to 256 (integers, 2n only)	1	External clock divider
:FUNction			
:MODE	FIXed   USER   SEQuence   ASEQuence   MODulation   PULSe	FIX	Selects function type
:POWer			AC coupled (RF) output
[:LEVe]			
[:AMPLitude]	-5 to 5   MINimum   MAXimum	0	AC amplitude in dBm
:ROSCillator			
:SOURce	INTernal   EXTernal	INT	
[:EXTernal]			
:FREQuency	10e6 to 100e6	100e6	
:VOLTage			DC coupled output
:DAC	50e-3 to 500e-3   MINimum   MAXimum	500e-3	DAC amplitude in volts
[:LEVe]			
[:AMPLitude]	50e-3 to 2   MINimum   MAXimum	500e-3	DC amplitude in volts
:OFFSet	-1.5 to 1.5   MINimum   MAXimum	0	DC offset in volts



**:OUTPut:COUPling{DC | DAC | AC}{?}****Description**

Use this command to set or query the type of the output amplifier that will be placed between the DAC and the output connectors. The 81180A has three separate amplifiers for the output path: the DAC and DC-coupled amplifier allow control of amplitude and offset while the AC-coupled path provides control over RF power only.

**Parameters**

Name	Type	Default	Description
DC	Discrete	DC	Selects a DC-coupled amplifier path for the output amplifier. Use the volt and volt:offs commands to control output amplitude and offset.
DAC	Discrete		Selects a DC-coupled direct DAC path for the output stage. Use the vol:DACT and volt:offs commands to control output amplitude and offset.
AC	Discrete		Selects the AC-coupled path for the output amplifier. Use the pow command to control RF power at the output connector.

**Response**

The 81180A will return DC, DAC, or AC depending on the current output coupling setting.

**:OUTPut{OFF | ON | 0 | 1}{?}****Description**

This command will set or query the output state of the 81180A. Note that for safety, the outputs always default to off, even if the last instrument setting before power down was on. Also note that the off setting leaves the output connector connected to the amplifier path but no signal is being generated while in the off state.

**Parameters**

Range	Type	Default	Description
0-1	Discrete	0	Sets the output on and off

**Response**

The 81180A will return 1 if the output is on, or 0 if the output is off.

**:OUTPut:SYNC:FUNcTion{PULSe | WCOMplete}{?}****Description**

Use this command to set or query the shape of the sync pulse. Pulse output can be programmed for position and width and the WCOM (wave complete) as fixed and cannot be moved from its origin.

**Parameters**

Name	Type	Default	Description
PULSe	Discrete	PULS	Selects the pulse shape as the output waveform for the sync output. The minimum pulse width is 32 sample clock periods. However, the width can be

WCOMplete	Discrete	<p>expanded to the full length of the waveform in increments of 32 points. Program the sync pulse width using the outp:sync:wid command and its relative position to the start of the waveform using the outp:sync:pos command.</p> <p>This will select the waveform complete pulse option. The sync output will transition high at the beginning of the waveform and will return to low after the waveform cycle has been completed. Width and position control of the sync pulse is not available when this option is selected.</p>
-----------	----------	---

**Response**

The 81180A will return PULS or WCOM, depending on the selected SYNC waveform function.

**:OUTPut:SYNC:POSiTion<position>(?)**

**Description**

This command will program the 81180A SYNC position. This command is active in arbitrary (USER) mode only.

**Parameters**

Name	Range	Type	Default	Description
<position>	0 to 16e6-32	Numeric (Integer only)	0	Will set the SYNC position in waveform points. The sync position can be programmed in increments of 32 points to the maximum length of the waveform providing that the number is divisible by 32. The range is extended to 64e6-32 when option -264 is installed; 16e6 memory size is standard.

**Response**

The 81180A will return the present SYNC position value.

**:OUTPut:SYNC:WIDTh<width>(?)**

**Description**

This command will program the 81180A SYNC width. This command is active in arbitrary (USER) mode only.

**Parameters**

Name	Range	Type	Default	Description
<width>	32 to n-32	Numeric (Integer only)	32	Will set the SYNC width in waveform points. The sync width can be programmed in increments of 32 points minimum. "n" designates the length of the segment.

**Response**

The 81180A will return the present SYNC width value.

**:OUTPut:SYNC:SOURce{CH1 | CH2 | 1 | 2}(?)****Description**

Use this command to set or query the source of the sync pulse. There is only one sync output connector on the front panel and this connector can be programmed to source from channel 1 or channel 2 waveforms.

This command does not affect the single channel version. Channel 1 position and width and channel 2 position and width are programmed individually for each channel.

**Parameters**

Name	Type	Default	Description
CH1   1	Discrete	CH1	This will select channel 1 as the source for generating the sync pulse.
CH2   2	Discrete		Defines channel 2 as the source for generating the sync pulse.

**Response**

The 81180A will return CH1 or CH2 depending on the selected SYNC source option.

**:OUTPut:SYNC{OFF | ON | 0 | 1}(?)****Description**

This command will set or query the state of the sync output. Note that for safety, the outputs always default to off, even if the last instrument setting before power down was on. Also note that the off setting leaves the sync output connector connected to the amplifier path, but no signal is being generated while in the off state.

**Parameters**

Range	Type	Default	Description
0-1	Discrete	0	Sets the output on and off

**Response**

The 81180A will return 1 if the sync output is on, or 0 if the sync output is off.

**:FREQuency{<freq> | MINimum | MAXimum}(?)****Description**

Use this command to set or query the frequency of the standard waveforms in units of hertz (Hz). This parameter has no effect on arbitrary waveforms.

**Parameters**

Name	Range	Type	Default	Description
<freq>	10e-3 to 250e6	Numeric	10e6	Will set the frequency of the standard waveform in units of Hz. The frequency command can be used with resolutions up to 8 digits.
<MINimum>		Discrete		Will set the frequency of the standard waveform to the lowest possible frequency (10e3).
<MAXimum>		Discrete		Will set the frequency of the standard waveform to the highest possible frequency (250e6).

## Response

The 81180A will return the present frequency value. The returned value will be in standard scientific format (for example: 100MHz would be returned as 100e-3 – positive numbers are unsigned).

## :FREQuency:RASTer{<sclk> | MINimum | MAXimum}(?)

### Description

Use this command to set or query the sample clock frequency of the arbitrary waveform in units of samples per second (Sa/s). This parameter has no effect on standard waveforms.

### Parameters

Name	Range	Type	Default	Description
<sclk>	10e6 to 4.2e9	Numeric	1e9	Will set the sample clock frequency of the arbitrary and sequenced waveform in units of Sa/s. The sample clock command can be programmed with resolutions up to 8 digits.
<MINimu m>		Discrete		Will set the sample clock frequency to the lowest possible frequency (10e6).
<MAXim um>		Discrete		Will set the frequency of the standard waveform to the highest possible frequency (4.2e9).

### Response

The 81180A will return the present sample clock frequency value. The returned value will be in standard scientific format (for example: 1 GHz would be returned as 1e9 – positive numbers are unsigned).

## :FREQuency:RASTer:SOURce{INTernal | EXTernal}(?)

### Description

Use this command to select or query the source of the sample clock generator. This command affects all of the waveforms, as the internal clock is removed and external clock is applied. Make sure that a valid clock is applied to the external clock input before you change the option to external, because the generator cannot generate waveforms without a valid source of sample clock generator. Note that the internal sample clock generator is unique for each channel however, when an external clock source is selected, the same source is applied to both channels. Use the freq:rast:sour:div command for applications that require different sample clock frequencies per channel.

### Parameters

Name	Type	Default	Description
INTernal	Discrete	INT	Selects the internal clock generator as the main clock source.
EXTernal	Discrete		Activates the external sample clock input. A valid signal must be applied from the external signal to the 81180A for the generator to continue generating waveforms. Observe the input level and limitations before connecting an external signal to the external sample clock input.

**Response**

The 81180A will return INT, or EXT depending on the current sample clock source setting.

**:FREQuency:RASTer: DIVider<divider>(?)****Description**

Use this command to set or query the sample clock frequency divider. The same external sample clock signal is fed to both channels, so if different frequencies are required, use the sample clock divider to get different sample clocks to each channel.

**Parameters**

Name	Range	Type	Default	Description
<sclk>	1 to 256	Numeric (integer only)	1	Will set the external sample clock frequency divider. Except 1 (no divider), all divider values must be integers - (2n). Each channel may be programmed separately to have a different divider value.

**Response**

The 81180A will return the present external clock divider value in integer number.

**FUNCTion:MODE{FIXed | USER | SEQuence | ASEQuence | MODulation | PULSe}(?)****Description**

Use this command to set or query the type of waveform that will be available at the output connector.

**Parameters**

Name	Type	Default	Description
FIXed	Discrete	FIX	Selects the standard waveform shapes. There is an array of waveforms that is built into the program. You can find these waveform shapes in the standard waveforms section.
USER	Discrete		Selects the arbitrary waveform shapes. Arbitrary waveforms must be loaded to the 81180A memory before they can be replayed. You can find information on arbitrary waveforms in the appropriate sections in this manual.
SEQuenced	Discrete		Selects the sequenced waveform output. To generate a sequence, you must first download waveform coordinates to different segments and then build a sequence table to generate a complex waveform that is using these segments.
ASEQuenced	Discrete		Selects the advanced sequencing waveform output. To generate an advanced sequences, you must first download waveform coordinates to different segments, use these waveforms to design sequences and then use these sequences to build an advanced sequence table where sequences are

MODulated	Discrete	sequenced to create an extremely complex waveform. Selects the modulated waveforms. There is an array of built-in modulation schemes. However, you can also build custom modulation schemes using the arbitrary function.
PULSe	Discrete	Selects the digital pulse function. The digital pulse function behaves and reacts to the programming sequence as a regular pulse generator, except the waveforms are digitally constructed and generated from the arbitrary memory.

### Response

The 81180A will return FIX, USER, SEQ, ASEQ, MOD, or PULS depending on the present 81180A output function mode setting.

### :POWer{<power> | MINimum | MAXimum}(?)

#### Description

Use this command to set or query the output power. This parameter affects the AC output path only. Use the command `outp:coup ac` to modify the output path to ac-coupled. The 81180A displays a calibrated value when on load impedance of 50  $\Omega$ .

#### Parameters

Name	Range	Type	Default	Description
<power>	-5 to 5	Numeric	0	Will set the RF power in units of dBm. The display shows the correct power level only when the output cable is terminated into 50 $\Omega$ .
<MINimum>		Discrete		Will set the power to the lowest possible level (-8 dBm).
MAXimum>		Discrete		Will set the power to the highest possible level (8 dBm).

#### Response

The 81180A will return the present power value. The returned value will be in standard scientific format (for example: 100 mdBm would be returned as 100e-3 – positive numbers are unsigned).

### :ROSCillator:SOURce{INTernal | EXTernal}(?)

#### Description

Use this command to set or query the source of the 10 MHz reference. This source defines the accuracy and stability of the clock generator. The internal reference has an accuracy and stability of 1 ppm; applications requiring higher accuracy or stability can use the external reference option and apply there an improved 10 MHz signal.

#### Parameters

Name	Type	Default	Description
INTernal	Discrete	INT	Selects an internal source. The internal source is a

EXTernal	Discrete	TCXO (temperature compensated crystal oscillator) device that has 1ppm accuracy and stability over the operating temperature range. Reroutes the 10 MHz source to the external reference input. An external reference must be connected to the 81180A for it to continue with its normal operation.
----------	----------	--

**Response**

The 81180A will return INT, or EXT depending on the present 10 MHz clock reference source setting.

**:ROSCillator:FREQUENCY<frequency>(?)****Description**

Use this command to set or query the frequency range that will be applied to the reference oscillator input. The frequency value must be close to the value of the external frequency, because it sets up the PLL's for the reference oscillator to accept and lock on the correct external frequency value.

**Parameters**

Name	Range	Type	Default	Description
<frequen cy>	10e6 to 100e6	Numeric	100e6	Will set frequency range for the internal PLL that locks the external frequency reference.

**Response**

The 81180A will return the present reference frequency value. The returned value will be in standard scientific format (for example: 10 MHz would be returned as 10e6).

**:VOLTage{<dc\_couple\_voltage> | MINimum | MAXimum}(?)****Description**

Use this command to set or query the amplitude of the waveform when routed through the DC path. This parameter affects the DC output paths only. Use the command outp:coup dc to modify the output path to dc-coupled. The 81180A displays a calibrated value when on load impedance of 50 Ω. Offset and amplitude settings are independent providing that the |offset + amplitude/2| value does not exceed the specified voltage window.

**Parameters**

Name	Range	Type	Default	Description
<dc_cou ple_volta ge>	50e-3 to 2	Numeric	500e-3	Will set the offset of the output waveform in units of volts. The display shows the correct amplitude level only when the output cable is terminated into 50 Ω.
<MINim um>		Discrete		Will set the amplitude to the lowest possible DAC level (50e-3).
MAXimu m>		Discrete		Will set the amplitude to the highest possible DAC level (2).

**Response**

The 81180A will return the present dac amplitude value. The returned value will be in standard scientific format (for example: 100 mV would be returned as 100e-3 – positive numbers are unsigned).

### **:VOLTage:DAC{<dac\_couple\_voltage> | MINimum | MAXimum}{?}**

#### **Description**

Use this command to set or query the amplitude of the waveform when routed through the DAC path. This parameter affects the DAC output path only. Use the command `outp:coup dac` to modify the output path to dac-coupled. The 81180A displays a calibrated value when on load impedance of 50 Ω. Offset and amplitude settings are independent providing that the  $|\text{offset} + \text{amplitude}/2|$  value does not exceed the specified voltage window.

#### **Parameters**

<b>Name</b>	<b>Range</b>	<b>Type</b>	<b>Default</b>	<b>Description</b>
<dac_co uple_volt age>	50e-3 to 500e-3	Numeric	500e-3	Will set the offset of the output waveform in units of volts. The display shows the correct amplitude level only when the output cable is terminated into 50 Ω.
<MINim um>		Discrete		Will set the amplitude to the lowest possible DAC level (50e-3).
<MAXim um>		Discrete		Will set the amplitude to the highest possible DAC level (500e-3).

#### **Response**

The 81180A will return the present dac amplitude value. The returned value will be in standard scientific format (for example: 100 mV would be returned as 100e-3 – positive numbers are unsigned).

### **:VOLTage:OFFSet{<offset> | MINimum | MAXimum}{?}**

#### **Description**

Use this command to set or query the dc offset of the output waveform. This parameter affects the DAC and the DC output paths only. Use the command `outp:coup dc` to modify the output path to dc-coupled. The 81180A displays a calibrated value when on load impedance of 50 Ω. Offset and amplitude settings are independent providing that the  $|\text{offset} + \text{amplitude}|$  value does not exceed the specified amplitude window.

#### **Parameters**

<b>Name</b>	<b>Range</b>	<b>Type</b>	<b>Default</b>	<b>Description</b>
<offset>	-1.5 to 1.5	Numeric	0	Will set the offset of the output waveform in units of volts. The display shows the correct amplitude level only when the output cable is terminated into 50 Ω.
<MINim um>		Discrete		Will set the offset to the lowest possible level (-1.5).
<MAXim um>		Discrete		Will set the offset to the highest possible level (1.5).

#### **Response**

The 81180A will return the present dc offset value. The returned value will be in standard scientific format (for example: 100 mV would be returned as 100e-3 – positive numbers are unsigned).



#### 4.12.4 Marker Output Control Commands

##### Marker Output Control Commands

The Marker Output Control Commands group is used for programming the characteristics of the marker outputs. Each channel has two differential marker outputs. These are located on the rear panel. Each marker can be programmed to have unique properties such as: delay, position, width and level. Simple front panel programming allows creation of one marker for each marker output however, markers can also be programmed remotely as bits D12 and D13 of the waveform data (see *Figure 4-3*), to program arbitrary patterns on the marker outputs.

Additional information on the various marker output functions is given in Chapter 3. Factory defaults after \*RST are shown in the default column. Parameter low and high limits are given where applicable. Use the commands in *Table 4-5* to set up the 81180A marker outputs and their associated parameters.



When markers are programmed from the front panel, the 81180A generates one marker transition only for each marker output. The user has the freedom to turn markers on and off and modify marker attributes such as delay, position, width and levels. Internally, markers are programmed as part of the waveform and, when modified from the front panel, the firmware sets and remembers where markers were placed so every time that marker attributes are modified, the firmware knows where these attributes are stored and re-writes the entire waveform memory with the new attributes.

It is different when markers are programmed from remote; internal attributes are not visible to the external user and therefore, if you programmed marker attributes from the front panel and then did the same from remote, there is danger that marker transitions are present at unexpected locations. To avoid such errors, always set the mark:width to 0 for all markers and only then download waveforms that have marker attributes on bits D12 and D13.

---

**Table 4-5: Marker Output Control Commands Summary**

Keyword	Parameter Form	Default	Notes
[ :SOURce]			
:MARKer[1   2]			Selects active marker
:DELay	0 to 3e-9	0	Delay from SYNC
[ :STATe]	OFF   ON   0   1	0	Toggles marker on/off
:POSition	0 to n-4 (n = segment length)	0	Position from start
:WIDTh	0 to n-4 (n = segment length)	64	Marker width
:VOLTage			
[ :LEVel]			
:HIGH	0.5 to 1.25	0.5	Marker high level
:LOW	0 to 0.8	0	Marker low level

**:MARKer[1 | 2]:DELay<delay>(?)**

**Description**

Use this command to set or query the delay of the marker output. The delay is measured from the sync output in units of seconds. The marker has an initial width of 4 sample clock periods and an amplitude swing of 0 to 0.5 V. Use the mark[1 | 2]:wid command to change the marker pulse width and mark[1 | 2]:volt:high | low to change the marker amplitude levels.

**Parameters**

Name	Range	Type	Default	Description
<delay>	0 to 3e-9	Numeric	0	Will set marker delay value in units of seconds. Each channel has two separate markers that can be programmed to have unique delays and amplitude levels. Note that you can program D12 and D13 to create multiple markers along the waveform length however, in this case you must remove the default marker from the waveform map by setting the width parameter <i>mark:wid 0</i> .

**Response**

The 81180A will return the present marker delay value. The returned value will be in standard scientific format (for example: 100 μs would be returned as 100e-6 – positive numbers are unsigned).

**:MARKer[1 | 2]{OFF | ON | 0 | 1}(?)**

**Description**

This command will set or query the state of the marker outputs. Note that for safety, the outputs always default to off, even if the last instrument setting before power down was on. The on/off setting affects both markers simultaneously on each channel.

**Parameters**

Range	Type	Default	Description
0-1	Discrete	0	Sets the marker outputs on and off

**Response**

The 81180A will return 1 if the marker outputs are ON, or 0 if the marker outputs are OFF.

**:MARKer[1 | 2]:POSition<position>(?)****Description**

Use this command to set or query the position of the marker output. The position is defined from the waveform first point in units of waveform points (sample clock periods). The marker has an initial width of 4 sample clock periods and an amplitude swing of 0 to 0.5 V. Use the `mark[1 | 2]:wid` command to change the marker pulse width and `mark[1 | 2]:volt:high | low` to change the marker amplitude levels.

**Parameters**

Name	Range	Type	Default	Description
<positio n>	0 to n-4	Numeric	0	Will set marker position relative to the waveform start point in units of waveform points. The position range is from 0 to the last point of the waveform, minus 4. You can program the position with increments of 4 points. Note that you can program D12 and D13 to create multiple markers along the waveform length however, in this case you must remove the default marker from the waveform map by setting the width parameter <i>mark:wid 0</i> .

**Response**

The 81180A will return the present marker position value in units of waveform points.

**:MARKer[1 | 2]:WIDth<width>(?)****Description**

Use this command to set or query the width of the marker output. The width is defined in units of waveform points (sample clock periods). The marker has an initial amplitude swing of 0 to 0.5 V. Use the command `mark[1 | 2]:volt:high | low` to change the marker amplitude levels.

**Parameters**

Name	Range	Type	Default	Description
<width>	0 to n-4	Numeric	64	Will set marker width in units of waveform points. The width range is from 0 to the last point of the waveform less 4. You can program the width in increments of 4 points. Note that you can program D12 and D13 to create multiple markers along the waveform length however, in this case you must remove the default marker from the waveform map by setting the width parameter to "0".

**Response**

The 81180A will return the present marker width value in units of waveform points.

### **:MARKer[1|2]:VOLTage:HIGH<hi\_level>(?)**

#### **Description**

Use this command to set or query the high level of the marker output. The high level is defined in units of volts. High and low levels can be programmed independently as long as the amplitude window remains within 1.25 V.

#### **Parameters**

<b>Name</b>	<b>Range</b>	<b>Type</b>	<b>Default</b>	<b>Description</b>
<hi_level>	0.5 to 1.25	Numeric	0.5	Will program the marker high level in units of volts. Each marker can be programmed to a different low- and high-level setting. The high level is calibrated when the cable is terminated into a 50 $\Omega$ load.

#### **Response**

The 81180A will return the present marker high-level value. The returned value will be in standard scientific format (for example: 0.01 V would be returned as 10e-3 – positive numbers are unsigned).

### **:MARKer[1|2]:VOLTage:LOW<lo\_level>(?)**

#### **Description**

Use this command to set or query the high level of the marker output. The high level is defined in units of volts. High and low levels can be programmed independently as long as the amplitude window remains within 1.4 V.

#### **Parameters**

<b>Name</b>	<b>Range</b>	<b>Type</b>	<b>Default</b>	<b>Description</b>
<lo_level>	0 to 0.8	Numeric	0	Will program the marker low level in units of volts. Each marker can be programmed to a different low- and high- level setting. The low level is calibrated when the cable is terminated into a 50 $\Omega$ load.

#### **Response**

The 81180A will return the present marker low-level value. The returned value will be in standard scientific format (for example: 0.01 V would be returned as 10e-3 – positive numbers are unsigned).

### 4.12.5 Standard Waveforms Control Commands

#### Standard Waveforms Control Commands

Use this group to control the shape and parameters of the standard waveforms functions. The commands in this group will affect the output only when the 81180A has been programmed to generate standard waveforms. In standard waveform mode, some waveform coordinates are stored in tables and some are computed every time a waveform is being selected or modified. Expect small delays after the commands have been sent, because the waveform is recomputed and refreshed with every command.

Factory defaults after \*RST are shown in the Default column. Parameter range and low and high limits are listed, where applicable. Use the commands in *Table 4-6* to set up the 81180A standard waveforms and their associated parameters.

**Table 4-6: Standard Waveforms Control Commands Summary**

Keyword	Parameter Form	Default	Notes
[:SOURce]			
:FUNction			
:SHApe	SINusoid   TRiangle   SQUare   RAMP   SINC   GAUSSian   EXPonential   NOISe   DC	SIN	Standard function shape
:SINusoid			
:PHASe	0 to 360	0	
:TRiangle			
:PHASe	0 to 360	0	
:SQUare			
:DCYCLE	0 to 99.9	50	
:RAMP			
:DELay	0 to 99.99	10	
:TRANsition			
[[:LEADing]	0 to 99.99	60	
:TRAILing	0 to 99.99	30	
:SINC			
:NCYCLE	4 to 100	10	
:GAUSSian			
:EXPonent	1 to 200	10	
:EXPonential			
:EXPonent	-100 to 100	-10	
:DC			
[[:OFFSet]	-1.5 to 1.5	0	DC coupled only

**FUNcTion:SHAPE{SINusoid | TRIangle | SQUare | RAMP | SINC | GAUSSian | EXPonential | DC | NOISe}(?)**

**Description**

Use this command to set or query the type of waveform that will be available at the output connector. This command will affect the 81180A only when the standard waveforms output has been programmed. Select the standard waveforms using the func:mode fix command.

**Parameters**

Name	Type	Default	Description
SINusoid	Discrete	SIN	Selects the built-in sine waveform.
TRIangle	Discrete		Selects the built-in triangular waveform.
SQUare	Discrete		Selects the built-in square waveform.
RAMP	Discrete		Selects the built-in ramp waveform.
SINC	Discrete		Selects the built-in sinc waveform.
EXPonential	Discrete		Selects the built-in exponential waveform.
GAUSSian	Discrete		Selects the built-in gaussian waveform.
DC	Discrete		Selects the built-in DC waveform.
NOISe	Discrete		Selects the built-in noise waveform.

**Response**

The 81180A will return SIN, TRI, SQU, SPUL, RAMP, SINC, GAUS, EXP, DC, or NOIS depending on the selected waveform setting.

**SINusoid:PHASe<phase>(?)**

**Description**

Use this command to set or query the start phase for the standard sine waveform.

**Parameters**

Name	Range	Type	Default	Description
<phase>	0 to 360	Numeric	0	Programs the start phase parameter in units of degrees. Sine phase resolution is 0.01° limited however at high frequencies, depending on the number of waveform points that are used to create the sine shape.

**Response**

The 81180A will return the present start phase value in units of degrees.

**TRIangle:PHASe<phase>(?)**

**Description**

Use this command to set or query the start phase for the standard triangular waveform.

**Parameters**

Name	Range	Type	Default	Description
<phase>	0 to 360	Numeric	0	Programs the start phase parameter in units of

degrees. Triangle phase resolution is 0.01° limited however at high frequencies, depending on the number of waveform points that are used to create the shape.

**Response**

The 81180A will return the present start phase value in units of degrees.

**SQUare:DCYClE<duty\_cycle>(?)****Description**

Use this command to set or query the duty cycle of the standard square waveform.

**Parameters**

Name	Range	Type	Default	Description
<duty_cyc0 le>	0 to 99.99	Numeric	50	Programs the duty cycle of the standard square waveform in units of percent. Duty cycle setting resolution is limited to 0.01% of the square wave period.

**Response**

The 81180A will return the present duty cycle value in units of percent.

**RAMP:DELay<delay>(?)****Description**

Use this command to set or query the delay of the standard ramp waveform. The delay parameter defines the time that will lapse from the waveform start to the first transition of the ramp period.

**Parameters**

Name	Range	Type	Default	Description
<delay>	0 to 99.99	Numeric	10	Programs the ramp delay parameter in units of percent

**Response**

The 81180A will return the present ramp delay value in units of percent.

**Ramp:TRANsition<rise>(?)****Description**

Use this command to set or query the ramp transition time from low to high. The rise time parameter defines the time that will lapse from the first transition to high, until the ramp reaches its high-level value.

**Parameters**

Name	Range	Type	Default	Description
<rise>	0 to 99.99	Numeric	60	Programs the ramp rise time parameter in units of percent.

**Response**

The 81180A will return the present rise time value in units of percent.

### **RAMP:TRANSition:TRAIling<fall>(?)**

#### **Description**

Use this command to set or query the ramp transition time from high to low. The fall time parameter defines the time that will lapse from the first transition to low, until the ramp reaches its low level value.

#### **Parameters**

<b>Name</b>	<b>Range</b>	<b>Type</b>	<b>Default</b>	<b>Description</b>
<fall>	0 to 99.99	Numeric	30	Programs the ramp fall time parameter in units of percent

#### **Response**

The 81180A will return the present fall time value in units of percent.

### **SINC:NCYCLe<N\_cycles>(?)**

#### **Description**

Use this command to set or query the number of "0-crossings" of the standard SINC pulse waveform.

#### **Parameters**

<b>Name</b>	<b>Range</b>	<b>Type</b>	<b>Default</b>	<b>Description</b>
<N_cycle >	4 to 100	Numeric (Integer only)	10	Programs the number of zero-crossings parameter.

#### **Response**

The 81180A will return an integer number depending on the current number of zero-crossing value.

### **GAUSSian:EXPonent<exp>(?)**

#### **Description**

Use this command to set or query the exponent for the standard Gaussian pulse waveform.

#### **Parameters**

<b>Name</b>	<b>Range</b>	<b>Type</b>	<b>Default</b>	<b>Description</b>
<exp>	1 to 200	Numeric (Integer only)	10	Programs the exponent parameter.

#### **Response**

The 81180A will return an integer number depending on the present exponent value.

### **EXPonential:EXPonent<exp>(?)**

#### **Description**

Use this command to set or query the exponent for the standard exponential pulse waveform.

#### **Parameters**

<b>Name</b>	<b>Range</b>	<b>Type</b>	<b>Default</b>	<b>Description</b>
<exp>	-100 to 100	Numeric (Integer only)	-10	Programs the exponent parameter.

#### **Response**

The 81180A will return an integer number, depending on the present exponent value.



**DC<offset>(?)****Description**

Use this command to set or query the offset of the DC function in units of volts.

**Parameters**

Name	Range	Type	Default	Description
<offset>	-1.5 to 1.5	Numeric	0	Programs the DC offset parameter in units of volts. Output amplifier path is automatically set to DC.

**Response**

The 81180A will return the present DC offset value in units of volts.

## 4.12.6 Arbitrary Waveforms Control Commands

### Arbitrary Waveforms Control Commands

This group is used to control the arbitrary waveforms and their respective parameters. This will allow you to create segments and download waveforms. Using these commands, you can also define segment size and delete some or all unwanted waveforms from your memory.

#### Generating Arbitrary Waveforms

Arbitrary waveforms are generated from digital data points, which are stored in a dedicated waveform memory. Each data point has a vertical resolution of 12 bits (16,384 points), i.e., each sample is placed on the vertical axis with a precision of 1/16,384. The 81180A has the following waveform memory capacity:

**16M** – standard memory configuration

**64M** – optional memory expansion

Each horizontal point has a unique address - the first being 00000 and the last depending on the memory option. In cases where smaller waveform lengths are required, the waveform memory can be divided into smaller segments.

When the instrument is programmed to output arbitrary waveforms, the clock samples the data points (one at a time) from address 0 to the last address. The rate at which each sample is replayed is defined by the sample clock rate parameter.

Unlike the built-in standard waveforms, arbitrary waveforms must first be loaded into the instrument's memory. Correct memory management is required for best utilization of the arbitrary memory. An explanation of how to manage the arbitrary waveform memory is given in the following paragraphs.

#### Arbitrary Memory Management

The arbitrary memory is comprised of a finite length of words. The maximum size arbitrary waveform that can be loaded into memory

depends on the option that is installed in your instrument. The various options are listed in Chapter 1 of this manual. If you purchased the 81180A within its basic configuration, you should expect to have 16 Meg words in each channel to load waveforms.

Waveforms are created using small sections of the arbitrary memory. The memory can be partitioned into smaller segments (up to 16k) and different waveforms can be loaded into each segment, each having a unique length. Minimum segment size is 320 points and can be increased by increments of 32 points. Information on how to partition the memory, define segment length and download waveform data to the 81180A is given in the following paragraphs. The arbitrary waveform commands are listed in *Table 4-7*. Factory defaults after \*RST are shown in the Default column. Parameter range and low and high limits are listed, where applicable.

**Table 4-7: Arbitrary Waveforms Commands Summary**

Keyword	Parameter Form	Default	Notes
:TRACe			
[:DATA]	#<header><binary_block>		Waveform data array
:DEFine	<segment #>,<320 to 16(64)e6>		Segment and length
:DELete			
[:NAME]	1 to 32,000		Delete one segment
:ALL			Delete all segments
:POINts?			Queries waveform length
:SELect	1 to 32,000	1	
:SOURce	BUS   EXTernal	BUS	Toggle control source
:TIMing	COHerent   IMMEDIATE	COH	Select timing
:SEGMent			
[:DATA]	#<header><binary_block>		Segment data array

**:TRACe#<header><binary\_block>**

**Description**

This command will download waveform data to the 81180A waveform memory. Waveform data is loaded to the 81180A using high-speed binary transfer. A special command is defined by IEEE-STD-488.2 for this purpose. High-speed binary transfer allows any 8-bit bytes (including extended ASCII code) to be transmitted in a message. This command is particularly useful for sending large quantities of data. As an example, the next command will download to the generator an arbitrary block of data of 1,024 points

TRACe#42048<binary\_block>

This command causes the transfer of 2,048 bytes of data (1,024 waveform points) into the active memory segment. The <header> is interpreted this way:

The ASCII "#" (\$23) designates the start of the binary data block.

"4" designates the number of digits that follow.

"2,048" is the even number of bytes to follow.

The generator accepts waveform samples as 16-bit integers, which are sent in two-byte words.

Therefore, the total number of bytes is always twice the number of data points in the waveform. For example, 20000 bytes are required to download a waveform with 10,000 points. The IEEE-STD-488.2 definition of Definite Length Arbitrary Block Data format is demonstrated in *Figure 4-1*.

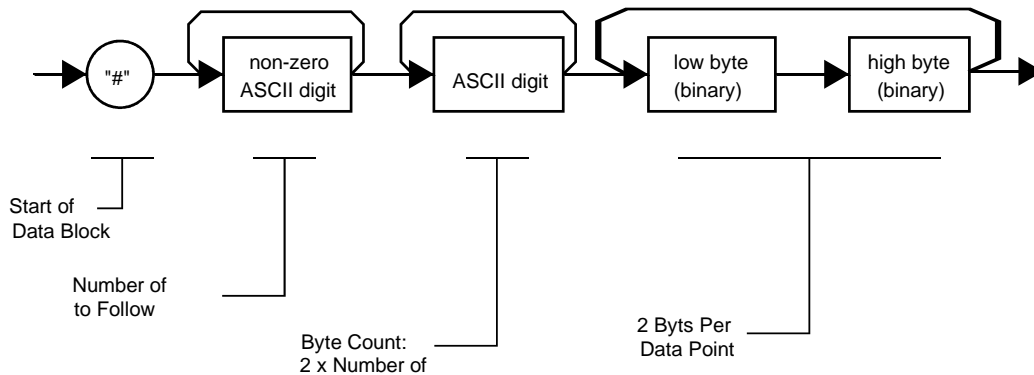

**Figure 4-1: Definite Length Arbitrary Block Data Format**

Transfer of definite length arbitrary block data must terminate with the EOI bit set. This way, carriage-return (CR – 0dH) and line feed (LF – 0aH) characters can be used as waveform data points and will not cause unexpected termination of the arbitrary block data.

<binary\_block> Represents waveform data.

The waveform data is made of 16-bit words however, programmers may choose to prepare the data in two bytes and arrange to download these two bytes in a sequence. *Figure 4-2* shows a waveform word that is acceptable for the 81180A. There are a number of points you should be aware of before you start preparing the data:

Waveform data points have 12-bit values - 0x000 to 0xFFF.

Data point range is 0 to 4,095 decimal for the 81180A. 0x000 corresponds to -2 V and 0xFFF corresponds to +2 V.

81180A data point 4,095 corresponds to full-scale amplitude setting. Point 2,048 corresponds to 0 V amplitude setting.

Figure 4-2 shows how to prepare the 16-bit word for a data point representation and Figure 4-3 shows how this data represents waveform and marker data and stop bit control.

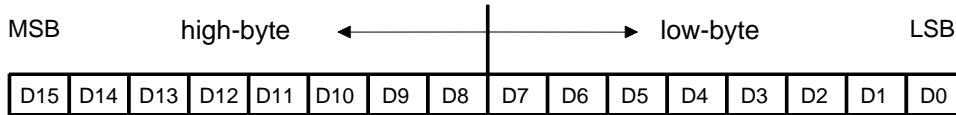

Figure 4-2: 16-bit Data Point Representation

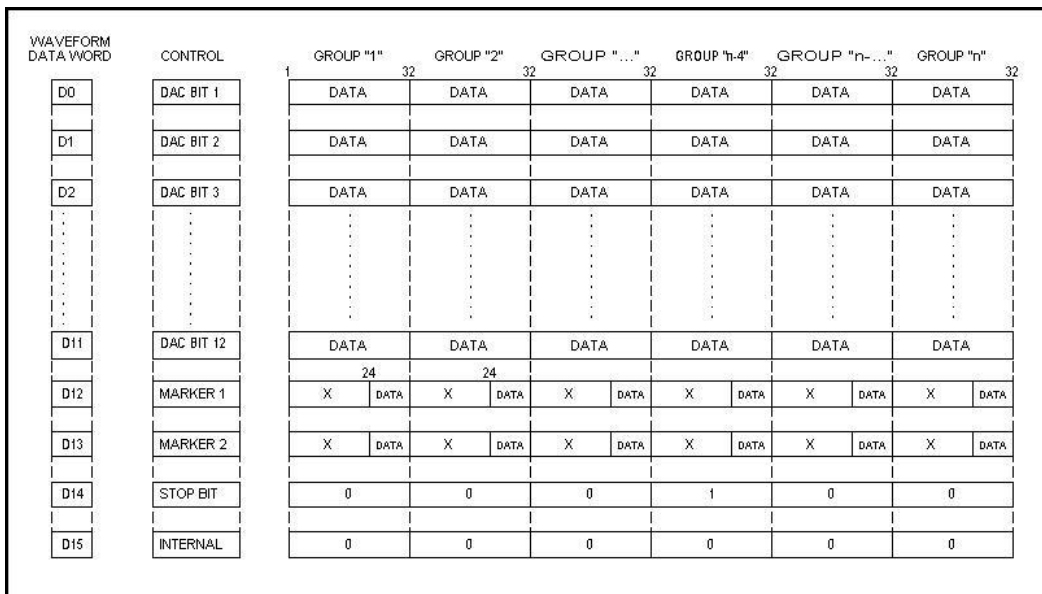

Figure 4-3: Waveform Data Word Representation

**Notes:**

1. Each group of data contains 32 words and therefore, waveform data is programmed in multiples of 32 words.
2. "0" data in the stop bit fields (D14) implies that all words are programmed with "0"; "1" data in the stop bit implies that all 32 words in the stop group must be programmed with "1". The stop bit defines the end of the waveform segment.
3. D15 must be programmed with "0", all words.

4. "X" data in D12 and D13 implies that the first 24 words you can place are "don't care" data but the last 8 words contain marker position data. You may place markers at any position along the waveform, but the data can be programmed in the last 8 words of a group of 32 words. Note: Marker resolution is 4 sample clock cycles. Marker position is programmed in groups of 4 waveform points, therefore programming "1" at each one of the last 8 waveform points will automatically set "1" over 4 waveform points.
5. Due to specific DAC multiplexing technique, placement of markers along the waveform scale is offset by 24 points. Use the following programming example to position the markers:

Conditions:

1. `mark_pos%4 = 0; mark_width%4 = 0;`
2. `mark_pos+24+mark_width < wave length`

Calculations:

```
marker_points = mark_width/4;
mark_pos = mark_pos+24;

for(ii=0; ii<marker_points; ii++)
{
wave_index = 24*((integer)(mark_pos/32) + 1) + mark_pos/4;
mark_pos = mark_pos+4;
}
```

#### Parameters

Name	Type	Description
<header>	Discrete	Contains information on the size of the binary block that contains waveform coordinates.
<binary_block>	Binary	Block of binary data that contains waveform data points (vertical coordinates), as explained above.

**:TRACe:DEFine<segment\_#>,<length>**

#### Description

Use this command to define the size of a specific memory segment. The final size of the arbitrary memory is 16,000,000 points (64,000,000 points optional). The memory can be partitioned to smaller segments, up to 32,000 segments. The total length of memory segments cannot exceed the size of the waveform memory.

#### Note

The 81180A operates in interlaced mode where thirty-two memory cells generate one byte of data. Therefore, segment size can be programmed in numbers evenly divisible by 32 only. For example, 2112 bytes is an acceptable length for a binary block. 2110 is not a multiple of 32 and therefore the generator will generate an error message if this segment length is used.

**Parameters**

Name	Range	Type	Default	Description
<segment _#>	1 to 16k	Numeric (integer only)	1	Selects the segment number of which will be programmed using this command.
<length>	320 to n	Numeric (integer only)		Programs the size of the selected segment. Minimum segment length is 320 points. The maximum (n) is limited by the size of the installed memory. Segment size can be programmed with increments of 32 points.

**:TRACe:DELeTe<segment\_#>****Description**

This command will delete a predefined segment from the working memory. The memory space that is being freed will be available for new waveforms, as long as the new waveform will be equal or smaller in size to the deleted segment. If the deleted segment is the last segment, then the size of another waveform written to the same segment is not limited. For example, let's consider two segments: the first being a 1024-point waveform and the second with 320 points. If you delete segment 1, you can reprogram another waveform to segment 1 with size to 1024 points. If you reprogram segment 1 with 1024 points, the instrument will generate an error and will not accept this waveform. On the other hand, if you delete segment 2, which was the last segment you programmed, you can reprogram this segment with waveforms having length limited only by the size of the remaining memory space.

**Parameters**

Name	Range	Type	Default	Description
<segment t_#>	1 to 32,000	Numeric (integer only)	1	Selects the segment number of which will be deleted

**:TRACe:DELeTe:ALL****Description**

This command will delete all predefined segments and will clear the entire waveform memory space. This command is particularly important in case you want to defragment the entire waveform memory and start building your waveform segments from scratch.

**:TRACe:POINts?****Description**

This command will query the number of points that were used for building up the active waveform.

**Response**

The 81180A will return the active waveform length as an integer number.

**:TRACe:SElect<segment\_#>(?)****Description**

Use this command to set or query the active waveform segment at the output connector. By selecting the active segment, you are performing two functions:

Successive: TRAC commands will affect the selected segment.

The SYNC output will be assigned to the selected segment. This behavior is especially important for sequence operation, where multiple segments form a large sequence. In this case, you can synchronize external devices exactly to the segment of interest.

**Parameters**

Name	Range	Type	Default	Description
<segment_#>	1 to 32,000	Numeric (Integer only)	1	Selects the active segment number.

**Response**

The 81180A will return the active waveform segment number.

**:TRACe:SElect:SOURce{BUS | EXTeRnal}(?)****Description**

Use this command to set or query the source of the segment select command. This defines from where the select command is expected to be received, causing a waveform segment change. Using the BUS option, waveforms can be selected using remote commands only. The EXT option transfers the control to a rear panel connector that allows dynamic selection of the active waveform segment. The rear panel connector has 9 pins of which 8 are used for parallel control bits and one line is used for data validation. Using the external waveform control, one can dynamically select a waveform from a preprogrammed list of 256 waveforms. The transition characteristics from waveform segment to another is programmed using the `trac:sel::tim` command.

**Parameters**

Name	Type	Default	Description
BUS	Discrete	BUS	Defines that waveform segments will be switched only when a remote command has been received.
EXTeRnal	Discrete		Defines that the segment control is transferred to a rear panel connector. The connector has 8 bits of parallel control lines that can switch between up to 256 segments.

**Response**

The 81180A will return BUS, or EXT depending on the present segment jump setting.

### **:TRACe:SElect:TIMing{COHerent|IMMEDIATE}{?}**

#### **Description**

Use this command to set or query the timing characteristics of the trace select command. This defines how the generator transitions from waveform to waveform. Use the coherent option to let the waveform complete before it jumps to the next waveform. Applications that require an unconditional jump can use the immediate option, where the generation of the current waveform is aborted and the new waveform is started immediately thereafter. This command affects the segment transition timing, regardless if the segment control is from remote or from the rear panel connector.

#### **Parameters**

<b>Name</b>	<b>Type</b>	<b>Default</b>	<b>Description</b>
COHerent	Discrete	COH	Defines that when a new waveform segment is selected, the transition to the new waveform will occur only when the current waveform has reached its end point.
IMMEDIATE	Discrete		Defines that when a new waveform segment is selected, the current waveform will be aborted and the transition to the new waveform will occur immediately, without waiting for the current waveform to reach its end point.

#### **Response**

The 81180A will return COH, or IMM depending on the present segment jump timing setting.

### **SEGment#<header><binary\_block>**

#### **Description**

This command will partition the waveform memory to smaller segments hence speeding up memory segmentation. The idea is that waveform segments can be built as one long waveform and then just use this command to split the memory to the appropriate memory segments. In this way, there is no need to define and download waveforms to individual segments.

Using this command, segment table data is loaded to the 81180A using high-speed binary transfer in a similar way to downloading waveform data with the trace command. High-speed binary transfer allows any 8-bit bytes (including extended ASCII code) to be transmitted in a message. This command is particularly useful for large number of segment. As an example, the next command will generate three segments with 12 bytes of data that contains segment size information.

```
SEGment#212<binary_block>
```

This command causes the transfer of 12 bytes of data (3 segments) into the segment table buffer. The <header> is interpreted this way:



- The ASCII "#" (\$23) designates the start of the binary data block.
- "2" designates the number of digits that follow.
- "12" is the number of bytes to follow. This number must divide by 4.

The generator accepts binary data as 32-bit integers, which are sent in two-byte words. Therefore, the total number of bytes is always 4 times the number of segments. For example, 36 bytes are required to download 9 segments to the segment table. The IEEE-STD-488.2 definition of Definite Length Arbitrary Block Data format is demonstrated in Figure 5-1. The transfer of definite length arbitrary block data must terminate with the EOI bit set. This way, carriage-return (CR – 0dH) and line feed (LF – 0aH) characters can be used as segment table data points and will not cause unexpected termination of the arbitrary block data.

The segment table data is made of 32-bit words however, the GPIB link has 8 data bus lines and accepts 8-bit words only. Therefore, the data has to be prepared as 32-bit words and rearranged as six 8-bit words before it can be used by the 81180A as segment table data. Figure 4-4 shows how to prepare the 32-bit word for the segment start address and size. Actually, only size is required because the segments are automatically numbered and their relative start address is automatically placed at the end of the last memory segment.

There are a number of points you should be aware of before you start preparing the data:

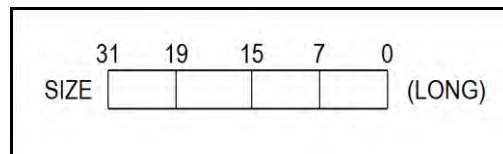

**Figure 4-4: Segment Size Array Example**

1. Each channel has its own segment table buffer. Therefore, make sure you selected the correct active channel (with the INST:SEL command) before you download segment table data to the generator.
2. SEGM# command overrides segment definitions, similar to the TRAC:DEL:ALL command.
3. Minimum number of segments is 1; maximum number of segments is 32,000
4. Maximum segment size depends on your installed option. With the basic 81180A you can program maximum 16M in one segment.
5. Segment table data has 32-bit values of which are used for segment size. Therefore, Data for each segment must have 4 bytes.
6. The number of bytes in a complete segment table must divide by 4. The 81180A has no control over data sent to its segment table during data transfer. Therefore, wrong data and/or incorrect number of bytes will cause erroneous memory partition.
7. The sample program below demonstrates the usage of the SEGM# command. This example generates a segment table with four entries: Segment 1 = 640 points, segment 2 = 1,024 points, segment 3 = 2,048 and segment 4 = 20,480 points. Regardless if you previously had any

segments defined previously, the segment index will start from 1 to n.

```
UINT_32 seg_data_inf[4], total_buff_bytes_num;
seg_data_inf[0] = 640;
seg_data_inf[1] = 1024;
seg_data_inf[2] = 2048;
seg_data_inf[3] = 20480;
total_buff_bytes_num = 4 * num_of_segments;
digits_num = (UINT_32)(log10((double) total_buff_bytes_num) + 1.0);
sprintf(cmd_str, ":segm #%d%d", digits_num, total_buff_bytes_num);
sendCmdNoNL (cmd_str);
h_vi.dwlData((unsigned char *)seg_data_inf, total_buff_bytes_num);
```

8. **SEGM#** command is extremely useful in case you need to define and download waveforms to a large number of segments otherwise, you would be using the TRAC:DEF command to define individual segments. In this case, you can further save programming sequences and download time by combining and downloading all of your waveform segments in one download command. Since segment definition does not modify memory contents, you can either download the waveform and then slice the memory segments or reverse the procedure; Either way, the process of downloading one waveform and then define the entire segment table with one command makes this process extremely efficient.
9. Unlike downloading individual waveforms to individual segments, one has to prepare a combined waveform for this one-shot download of multiple waveform segments. Information and considerations are provided in the trac#.

Consider the three segments as shown in the next figure, marked as segment 1, 400 points long, segment 2, 3,000 points long and segment 3, 5,000 points long. You can define each segment separately using the trac:def command and then, download waveform data to each defined memory segment.

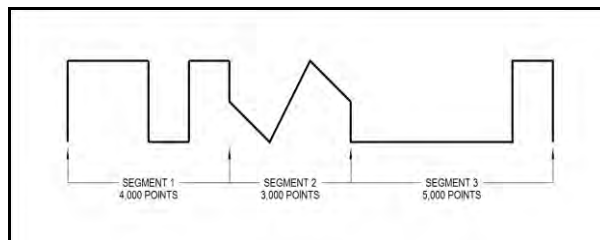

Now consider that you intend to use the **SEGM#** command and therefore you'd like to combine the three waveform segments into one single waveform. The following figure demonstrates how the new waveform looks like:

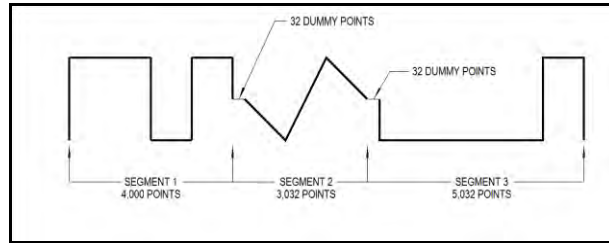

Notice that besides the first waveform, each of the following waveforms is artificially expanded by 32 dummy points right at the beginning of the segment. The value of these points should be the same as the value of the first point of the waveform segment. So now, the combined length of the three waveform segments is  $4,000+3,000+5,000+64 = 12,064$  points. And the header for the data download command should look as follows:

```
TRACe#624128<binary_block>
```

Where 6 defines that 6 digits will follow and 24128 is the number of bytes that will be downloaded using the binary download process. Explanation on the TRACe# command is given in the Arbitrary Waveform Commands section of this manual.

#### Parameters

Name	Type	Description
<binary_block>	Binary	Block of binary data that contains information on the segment table.

#### 4.12.7 Sequenced Waveforms Control Commands

**Sequenced Waveforms Control Commands** This group is used to control the sequenced waveforms and their respective parameters. This will allow you to create multiple sequence tables and modify segment loops and links. Also, use these commands to add or delete sequences from your instrument.

##### **Generating Sequenced Waveforms**

Sequenced waveforms are made of a number of arbitrary waveforms, which can be linked and looped in user-programmable order. Sequenced waveforms are generated from waveforms stored in the 81180A as memory segments. Therefore, before a sequence can be used, download waveform segments to the arbitrary memory. Information on how to partition the memory and how to download waveforms is given in this chapter

An example of how sequenced waveforms work is demonstrated in figures 1-6 through 1-9. The sequence generator lets you link and loop segments in user-defined order. *Figure 1-10* shows a sequence of waveforms that were stored in three different memory segments.

In general, sequences can be built one step at a time, using the seq:def command. The one-step method is slow and tedious. However, it allows better control for one who just begins his first sequence programming. Advanced users can download a complete sequence table using the binary sequence download option. The latter is much faster for applications requiring large sequence tables. Use the information below to understand sequence commands and how to implement them in your application.

The sequenced waveforms commands are listed in *Table 4-8*. Factory defaults after \*RST are shown in the Default column. Parameter range and low- and high-limits are listed, where applicable.

---

Table 4-8: Sequence Control Commands

Keyword	Parameter Form	Default	Notes
[:SOURce]			
:SEQuence			
:ADVance	AUTOmatic   ONCE   STEPped	AUTO	
[:DATA]	#<header><data_array>		
:DEFine	<step>,<segment_#>,<loops>,<jump_flag>		
:DELete			
[:NAME]	1 to 1,000		
:ALL			
:JUMP			
[:EVENT]	BUS   EVENT	BUS	Toggle jump source
:LENGth	3 to 32,768		Optional definition
:PREStep	WAVE   DC	WAVE	Active in conjunction with continuous and BUS source only
:SELect	1 to 1,000		
:SOURce	BUS   EXTernal	BUS	Toggle control source
:TIMing	COHerent   IMMEDIATE	COH	Jump timing
:ONCe			
:COUNT	1 to 1,048,575		
:SYNC			
:LOCK	<step_number>	1	Sync position in table

**:SEQuence:ADVance{AUTOmatic | ONCE | STEPped}{?}****Description**

This command will select the sequence advance mode. It defines how the output advances through the sequence steps. There are three advance modes: automatic, once and stepped.

In automatic advance mode, the routine goes through the steps automatically and if there are no jump flag, the sequence will end and then start over automatically. If a loop counter other than 1 is programmed for a specific step in the sequence, the step will loop n times and then automatically advance to the next step. The jump flag inhibits the progression to the next step until a valid signal at the event input releases the step to jump.

In once advance mode, the routine goes through the steps automatically and if there are no jump flags, the sequence will end and idle on a specific waveform, depending on the selected run mode. If the once counter is programmed to a value other than 1, the sequence will repeat itself n times. If a loop counter other than 1 is programmed for a specific step in the sequence, the step will loop n times and then automatically advance to the next step. The jump flag inhibits the progression to the next step, until a valid signal at the event input releases the step to jump.

In stepped advance mode, the routine goes through the steps only after a valid event signal. When the sequence is complete, the sequence repeats itself with valid event signals. Jump flags are ignored in stepped mode, but a loop counter other than 1 will repeat the step for n times with each event, before advancing to the next step.

### Parameters

Name	Type	Default	Description
AUTOmatic	Discrete	AUTO	Specifies continuous advance where the generator steps continuously to the end of the sequence table and repeats the sequence from the start. For example, if a sequence is made of three segments 1, 2 and 3, the sequence will generate an infinite number of 1,2,3,1,2,3,1,2,3...waveforms. Of course, each link (segment) can be programmed with its associated loop (repeat) number and jump flag to inhibit advancement until an event signal has been received.
ONCE	Discrete		This selects the once sequence advance mode, where the generator steps through the sequence table once automatically, except if the seq:once:coun programmed a value greater than 1.
STEPped	Discrete		Specifies the stepped sequence advance mode, where the generator steps to the next waveform only when a valid event signal has been received.

### Response

The 81180A will return the AUTO, ONCE, or STEP depending on the present sequence advance mode setting.

**:SEQ**uence#<header><data\_array>

### Description

This command will build a complete sequence table in one binary download. In this way, there is no need to define and download individual sequencer steps. Using this command, sequence table data is loaded to the 81180A using high-speed binary transfer in a similar way to downloading waveform data with the trace command. High-speed binary transfer allows any 8-bit bytes (including extended ASCII code) to be transmitted in a message. This command is particularly useful for long sequences that use a large number of segments and sequence steps. As an example, the next command will generate three-step sequence with 24 bytes of data that contains segment number, loops and jump flag option.

SEQuence#224<data\_array>

This command causes the transfer of 24 bytes of data (3-step sequence) to the sequence table buffer. The <header> is interpreted this way:

- The ASCII "#" (\$23) designates the start of the binary data block.
- "2" designates the number of digits that follow.
- "24" is the number of bytes to follow. This number must divide by 8.

The generator accepts binary data as 64-bit integers, which are sent in two-byte words. Therefore, the total number of bytes is always eight times the number of sequence steps. For example, 24 bytes are required to download 3 sequence steps to the sequence table. The transfer of definite length arbitrary block data must terminate with the EOI bit set. This way, carriage-return (CR – 0dH) and line feed (LF – 0aH) characters can be used as sequence data and will not cause unexpected termination of the arbitrary block data.

The code below demonstrates the data structure and the below figure shows how to prepare the 64-bit word for the sequence step, number of loops and jump flag option.

```
typedef struct
{
  UINT_32 loops;
  UINT_16 segment_number;
  UINT_16 jump_flag;
}
seqTableEntry_t;
```

There are a number of points you should be aware of before you start preparing the data:

1. Each channel has its own sequence table buffer. Therefore, make sure you select the correct active channel (with the INST:SEL command) before you download sequence table data to the generator
2. Minimum number of sequencer steps is 3; maximum number is 32,768
3. The number of bytes in a complete sequence table must divide by 8. The Model 81180A has no control over data sent to its sequence table during data transfer. Therefore, wrong data and/or incorrect number of bytes will cause erroneous sequence partition
4. Step numbers are assigned automatically in the same order as the structure is built. The first 8-byte structure forms step number 1 and the last, form step number n. As an example, for 100 steps sequence, one should build an array of 100 seqTableEntry\_t; entries.

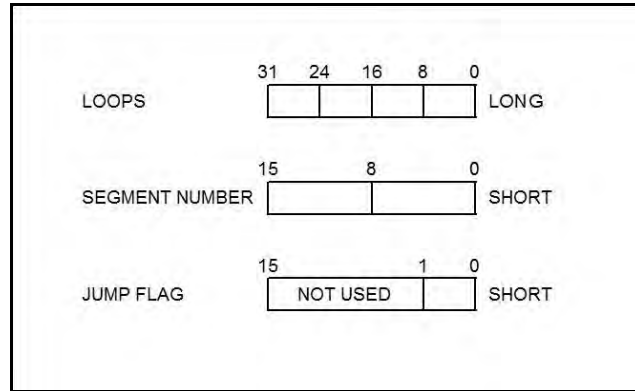

**Figure 4-5: 64-bit Sequence Table Download Format**

**Parameters**

Name	Type	Default	Description
<header>	Discrete		Sequence table header, defines the length of the binary <data_array>.
<data_array>	Binary		Block of binary data that contains information on the sequence table.

**:SEQ:DEFine<step>,<segment\_#>,<loops>,<jump\_flag>**

**Description**

Use this command to create a sequence table. It defines all of the parameters that are associated with the sequence step such as: step number, segment number, loops and jump flag. Each step in a sequence table must be programmed separately, except if the seq:data command is used to download a complete table in binary code. The seq:leng command can be used to first predefine the length of the sequence table. However, the length is adjusted automatically to the number of entries when the seq:def commands program each step.

**Parameters**

Name	Range	Type	Description
<step>	1 to 32,768	Numeric (integer only)	Programs the step in the sequence table. Steps are indexed from 1 to 32,768 and must be programmed in an ascending order. Empty step locations in a sequence table are not permitted. Minimum number of steps required to create a sequence is 3.
<segment_#>	1 to 32,000	Numeric (integer only)	Assigns a waveform segment to a specific step number. When encountered in the sequence table, the waveform that is associated with the step will be generated.
<loops>	1 to 1,048,575	Numeric (integer only)	Programs the repeat number of loops that a specific step will play, before advancing to the next step in the sequence.
<jump_flag>	0-1	Boolean	This flag specifies if the sequence will advance or hold



> on a specific step. “0” flag specifies normal advance, “1” flag specifies that the output will dwell on the current step and will advance to the next step only after a valid event has been received.

### TIPS

The 81180A attempts to rebuild the sequence table and restart the sequence every time you use the seq:def command, while your generator is in sequenced operating mode. Therefore, sending this command in sequenced mode will slow the programming process and the operation of the generator. Using the seq:del command in FIX or USER mode will greatly speed up programming time.

Sequencer steps are programmed from 1 to 32,768. However, minimum number of steps to create a sequence is 3.

### **:SEquence:DELeTe<sequence\_#>**

#### **Description**

The 81180A can store up to 1,000 different sequences for each channel. Use this command to delete unwanted sequences and to free memory space for fresh sequence tables. You can remove individual sequences regardless of their indexed order. For example, you can delete sequences 4, 7 and 15. Restoring deleted sequences is not a problem except their length must be equal or less than the deleted size. If you are not sure what to do, use the seq:del:all command and reprogram the entire sequence list.

#### **Parameters**

<b>Name</b>	<b>Range</b>	<b>Type</b>	<b>Default</b>	<b>Description</b>
<sequence_#>	1 to 1,000	Numeric (integer only)		Selects a specific sequence name that will be deleted.

### **:SEquence:DELeTe:ALL**

#### **Description**

Use this command to delete all sequences and to free space for fresh sequence tables.

### **:SEquence:JUMP{BUS | EVENT}(?)**

#### **Description**

Use this command to set or query the source of the jump signal. The jump signal is required for Auto and Stepped advance sequence modes. In Auto advance mode, the sequence will advance through the steps automatically until a jump bit = “1” is encountered, which will cause the generator to dwell on the step until a valid jump signal is asserted. In Stepped mode, the jump signal is required for every step to advance to the next waveform in the sequence ladder.

#### **Parameters**

<b>Name</b>	<b>Type</b>	<b>Default</b>	<b>Description</b>
BUS	Discrete	BUS	Defines that the sequence will advance to the next

EVENT	Discrete	step only when a remote trigger command such as *trg has been received. Defines that the sequence will advance to the next step only when a valid signal has been asserted to the Event input.
-------	----------	---

**Response**

The 81180A will return BUS, or EVEN depending on the present sequence jump setting.

**:SEquence:LENGth<length >(?)**

**Description**

Use this command to define or query the number of steps that will be programmed in a specific sequence table. Note that this command is optional if you program the sequence table using the seq# command, as this later command will automatically build the table with the number of programmed steps.

**Parameters**

Name	Range	Type	Default	Description
<length>	3 to 32,768	Numeric (integer3 only)		Defines the number of steps that will be programmed in a specific sequence table.

**Response**

The 81180A will return the present length value of the active sequence.

**:SEquence:PREStep{WAVE | DC}(?)**

**Description**

This command is valid only for armed continuous operation and where the selected arming event is BUS. This command is available from remote only and will not operate from exercising front panel controls. This command modifies the normal operation of the sequencer in such a way that it places a blank DC segment in front of the sequence table so, the first time the sequence is selected, a DC signal is present at the output and when triggered for the first time, the sequences steps to its first active waveform in the sequence table. At the end of the sequence, the sequence repeats itself without using the blank DC pre-step until aborted by the user.

**Parameters**

Name	Type	Default	Description
WAVE	Discrete	WAVE	This is the default option where immediately when a sequence function is selected, the first waveform in the sequence table is replayed till a legal event occurs that increments the waveform to the next step in the sequence table..
DC	Discrete		This is a special option that places a blank DC waveform in front of the sequence table but is not considered part of the sequence table..

**Response**

The 81180A will return WAVE, or DC depending on the present sequence pre-step setting.

**:SEQUence:SELEct<sequence\_#>(?)****Description**

Use this command to query or select an active sequence number to be generated at the output connector. Each channel can store up to 1,000 different sequence tables. By selecting the active sequence, successive seq:def commands will affect the selected sequence only.

**Parameters**

Name	Range	Type	Default	Description
<sequence_#>	1 to 1,000	Numeric (Integer only)	1	Selects an active sequence number. Subsequent programming will affect the active sequence only.

**Response**

The 81180A will return the active sequence number.

**:SEQUence:SELEct:SOURce{BUS | EXTErnal}(?)****Description**

Use this command to set or query the source of the sequence select command. This defines from where the select command is expected to be received, causing a sequence change. Using the BUS option, sequences can be selected using remote commands only. The EXT option transfers the control to a rear panel connector that allows dynamic selection of the active sequence. The rear panel connector has 9 pins, of which 8 are used for parallel control bits, and one line is used for data validation. Using the external sequence control, one can dynamically select a sequence from a preprogrammed list of 256 sequences. The transition characteristics from sequence to another is programmed using the seq:sel::tim command.

**Parameters**

Name	Type	Default	Description
BUS	Discrete	BUS	Defines that sequences will be switched only when a remote command has been received.
EXTErnal	Discrete		Defines that the sequence control is transferred to a rear panel connector. The connector has 8 bits of parallel control lines that can switch between up to 256 sequences.

**Response**

The 81180A will return BUS, or EXT depending on the present sequence select setting.

**:SEQUence:SELEct:TIMing{COHerent | IMMEDIATE}(?)****Description**

Use this command to set or query the timing characteristics of the sequence select command. This defines how the generator transitions from sequence to sequence. Use the coherent option to let the sequence complete, before it jumps to the next sequence. Applications that require an unconditional jump can use the immediate option, where the generation of the current sequence is aborted and the new sequence is started immediately thereafter.

This command affects the sequence transition timing, regardless if the sequence control is from remote or from the rear panel connector.

**Parameters**

Name	Type	Default	Description
COHerent	Discrete	COH	Defines that when a new sequence is selected, the transition to the new sequence will occur only when the current sequence has reached its end point.
IMMediate	Discrete		Defines that when a new sequence is selected, the current sequence will be aborted and the transition to the new sequence will occur immediately, without waiting for the current sequence to reach its end point.

**Response**

The 81180A will return COH, or IMM depending on the present sequence select timing setting.

**:SEquence:ONCE:COUNT<loops>(?)**

**Description**

Use this command to set or query the number of loops that a sequence will execute when its advance mode is programmed to ONCE. If a value other than 1 is programmed in the once counter database, then the sequence will execute to its last waveform and then return to an idle state. The sequence repeats n times, depending on the setting of the seq:once:coun command.

**Parameters**

Name	Range	Type	Default	Description
<loops >	1 to 1,048,575	Numeric (integer only)	1	Programs the loop counter for the once advance mode.

**Response**

The 81180A will return the active once loop counter value.

**:SEquence:SYNC:LOCK<step\_number>(?)**

**Description**

By default, the sequence generates a sync pulse on step number 1 of the sequence table. Use this command to move the sync output pulse to different steps. The width of the sync pulse is equal to the length of the waveform that is associated with it.

**Parameters**

Name	Type	Default	Description	
<step_number>	1 to 32,768 (integer only)	Numeric (integer only)	1	Programs the sync pulse to a required position along the sequence table steps.

**Response**

The 81180A will return an integer number depending on the current sync lock setting.

### 4.12.8 Advanced Sequencing Control Commands

**Advanced Sequencing Control Commands** This group is used to control a special incidence of the sequence generator where sequences, and not segments, are sequenced. Unlike the standard sequence generator that can store up to 1000 different sequence scenarios, the advanced sequencing generator can store only one sequence.

Generating an Advanced Sequence

The advanced sequence generator is similar to the standard sequence generator, except the sequence is made of sequences that were preloaded and stored in individual sequence tables. The advanced sequence generator has the ability to link and loop these sequences in user-programmable order. If you already built and used standard sequence tables then the procedure of building an advanced sequencing table is very similar. There are a number of tools that you can use to build an advanced sequencing table. In general, the advanced sequence table is built one step at a time using the `aseq:def` command. The one-step method is slow and tedious. However, it allows better control for someone who is just beginning their first sequence programming. Use the information below to understand the advanced sequencing commands and how to implement them in your application. The advanced sequencing commands are listed in *Table 4-9*. Factory defaults after `*RST` are shown in the Default column. Parameter range and low-and high-limits are listed, where applicable.

**Table 4-9: Sequence Control Commands**

Keyword	Parameter Form	Default	Notes
<code>[:SOURce]</code>			
<code>:ASEquence</code>			Advanced sequencing
<code>:ADVance</code>	<code>AUTOmatic   ONCE   STEPPed</code>	<code>AUTO</code>	
<code>:DATA</code>	<code>#&lt;header&gt;&lt;data_array&gt;</code>		
<code>:DEFine</code>	<code>&lt;step&gt;,&lt;sequence_#&gt;,&lt;loops&gt;,&lt;jump_flag&gt;</code>		
<code>:DELete</code>			Deletes table
<code>:LENGth</code>	<code>1 to 1,000</code>		Optional definition
<code>:ONCe</code>			
<code>:COUNT</code>	<code>1 to 1,048,575</code>		
<code>:SYNC</code>			
<code>:LOCK</code>	<code>1 to 1,000</code>	<code>1</code>	Sync position

**:ASEquence:ADVance{AUTOmatic | ONCE | STEPped}{?}**

**Description**

This command will select the sequence advance mode, which defines how the output advances through the sequencer steps. There are three advance modes: automatic, once and stepped.

In automatic advance mode, the routine goes through the steps automatically and if there are no jump flag, the sequence will end and then start over automatically. If a loop counter other than 1 is programmed for a specific step in the sequence, the step will loop n times and then automatically advance to the next step. The jump flag inhibits the circulation to the next step, until a valid signal at the event input releases the step to jump.

In once advance mode, the routine goes through the steps automatically and if there are no jump flag, the sequence will end and idle on a specific sequence, depending on the selected run mode. If the once counter is programmed to a value other than 1, the sequence will repeat itself n times. If a loop counter other than 1 is programmed for a specific step in the sequence, the step will loop n times and then automatically advance to the next step. The jump flag inhibits the propagation to the next step, until a valid signal at the event input releases the step to jump.

In stepped advance mode, the routine goes through the steps only after a valid event signal. When the sequence is complete, the sequence repeats itself with valid event signals. Jump flags are ignored in stepped mode, but loop counter other than 1 will repeat the step for n times with each event, before advancing to the next step.

**Parameters**

<b>Name</b>	<b>Type</b>	<b>Default</b>	<b>Description</b>
AUTOmatic	Discrete	AUTO	Specifies continuous advance where the generator steps continuously to the end of the sequence table and repeats the sequence from the start. For example, if a sequence is made of three sequences 1, 2 and 3, the sequence will generate an infinite number of 1,2,3,1,2,3,1,2,3...sequences. Of course, each link (sequence) can be programmed with its associated loop (repeat) number and jump flag to inhibit circulation until an event signal has been received.
ONCE	Discrete		This selects the once sequence advance mode, where the generator steps through the sequence table automatically once, except if the aseq:once:coun programmed a value greater than 1.
STEPped	Discrete		Specifies the stepped sequence advance mode, where the generator steps to the next sequence only when a valid event signal has been received.

**Response**

The 81180A will return the AUTO, ONCE, or STEP, depending on the present sequence advance mode setting.

**:ASEquence#<header><data\_array>**

### Description

This command will build a complete advanced sequence table in one binary download. In this way, there is no need to define and download individual sequence steps. Using this command, sequence table data is loaded to the 81180A using high-speed binary transfer in a similar way to downloading waveform data with the trace command. High-speed binary transfer allows any 8-bit bytes (including extended ASCII code) to be transmitted in a message. This command is particularly useful for long sequences that use a large number of sequences. As an example, the next command will generate three-step sequence with 24 bytes of data that contains sequence number, loops and jump flag option.

```
ASEquence#224<data_array>
```

This command causes the transfer of 24 bytes of data (3-step sequence) to the advanced sequence table buffer. The <header> is interpreted this way:

- The ASCII "#" (\$23) designates the start of the binary data block.
- "2" designates the number of digits that follow.
- "24" is the number of bytes to follow. This number must divide by 8.

The generator accepts binary data as 64-bit integers, which are sent in two-byte words. Therefore, the total number of bytes is always eight times the number of sequence steps. For example, 24 bytes are required to download 3 sequence steps to the advanced sequence table. The transfer of definite length arbitrary block data must terminate with the EOI bit set. This way, carriage-return (CR – 0dH) and line feed (LF – 0aH) characters can be used as sequence data and will not cause unexpected termination of the arbitrary block data.

The code below demonstrates the data structure and the below figure shows how to prepare the 64-bit word for the sequence step, number of loops and jump flag option.

```
typedef struct
{
  UINT_32 loops;
  UINT_16 sequence_number;
  UINT_16 jump_flag;
}
AseqTableEntry_t;
```

There are a number of points you should be aware of before you start preparing the data:

1. Each channel has its own advanced sequence table buffer. Therefore, make sure you select the correct active channel (with the INST:SEL command) before you download sequence table data to the generator
2. Minimum number of advanced sequencer steps is 3; maximum number is 32,768

3. The number of bytes in a complete sequence table must divide by 8. The Model 81180A has no control over data sent to its sequence table during data transfer. Therefore, wrong data and/or incorrect number of bytes will cause erroneous sequence partition
4. Step numbers are assigned automatically in the same order as the structure is built. The first 8-byte structure forms step number 1 and the last, form step number n. As an example, for 100 steps sequence, one should build an array of 100 AseqTableEntry t; entries.

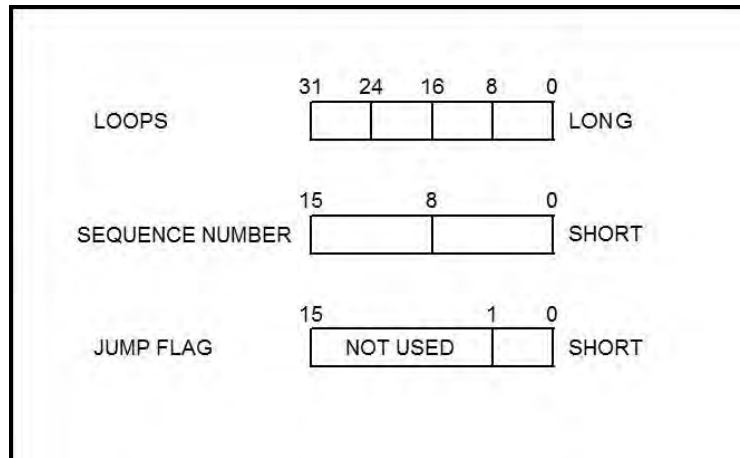

**Figure 4-6: 64-bit Sequence Table Download Format**

#### Parameters

Name	Type	Default	Description
<header>	Discrete		Advanced sequence table header, defines the length of the binary <data_array>.
<data_array>	Binary		Block of binary data that contains information on the sequence table.

**:ASEquence:DEFine<step>,<sequence\_#>,<loops>,<jump\_flag>**

#### Description

Use this command to create an advanced sequencing table. It defines all of the parameters that are associated with the sequence step such as: step number, sequence number, loops and jump flag. Each step in a sequence table must be programmed separately, except if the aseq:data command is used to download a complete table in binary code. The aseq:leng command can be used to first predefine the length of the sequence table. However, the length is adjusted automatically to the number of entries when the aseq:def commands program each step.

#### Parameters

Name	Range	Type	Description
<step>	3 to 1,000	Numeric (integer only)	Programs the step in the sequence table. Steps are indexed from 1 to 1,000 and must be programmed in an



<p>&lt;sequence_1 to 1,000 #&gt;</p>	<p>Numeric (integer only)</p>	<p>ascending order. Empty step locations in a sequence table are not permitted. Minimum number of steps required to create an advanced sequence table is 3. Assigns a sequence to a specific step number. When encountered in the sequence table, the sequence number that is associated with the step will be generated.</p>
<p>&lt;loops&gt; 1 to 1,048,575</p>	<p>Numeric integer only)</p>	<p>Programs the repeat number of loops that a specific step will play before advancing to the next step in the sequence.</p>
<p>&lt;jump_flag 0-1 &gt;</p>	<p>Boolean</p>	<p>This flag specifies if the sequence will advance or hold on a specific step. "0" flag specifies normal advance, "1" flag specifies that the output will dwell on the current step and will circulate to the next step only after a valid event has been received.</p>

 TIP

The 81180A attempts to rebuild the sequence table and restart the sequence every time you use the aseq:def command and while your generator is sequencing. Therefore, sending this command in sequenced mode will slow the programming process and the operation of the generator. Using the aseq:def command in FIX or USER mode will greatly speed up programming time.

**:ASEquence:DElete**

**Description**

Use this command to delete and reset the contents of the advanced sequencing table. No variables are associated with this command, because there is only one table available in the system.

**:ASEquence:LENGth<length >(?)**

**Description**

Use this command to define or query the number of steps that will be programmed in the advanced sequencing table. Note that this command is optional if you program the table using the aseq:data# command, as this later command will automatically build the table with the number of programmed steps.

**Parameters**

Name	Range	Type	Default	Description
<length>	1 to 1,000	Numeric (integer1 only)		Defines the number of steps that will be programmed in the advanced sequencing table.

**Response**

The 81180A will return the present length value of the sequence table.

### **:ASEquence:ONCE:COUNT<loops>(?)**

#### **Description**

Use this command to set or query the number of loops that the advanced sequence will execute when its advance mode is programmed to ONCE. If a value other than 1 is programmed in the once counter database, then the sequence will execute to its last waveform and return to an idle state. The sequence repeats n times, depending on the setting of the aseq:once:coun command.

#### **Parameters**

<b>Name</b>	<b>Range</b>	<b>Type</b>	<b>Default</b>	<b>Description</b>
<loops >	1 to 1,048,575	Numeric (integer only)	1	Programs the loop counter for the once advance mode.

#### **Response**

The 81180A will return the active once loop counter value.

### **:ASEquence:SYNC:LOCK<seq\_number>(?)**

#### **Description**

By default, the advanced sequence generates a sync pulse on step number 1 of the advanced sequence table. Use this command to move the sync output pulse to different steps. The width of the sync pulse is equal to the length of the sequence that is associated with it.

#### **Parameters**

<b>Name</b>	<b>Range</b>	<b>Type</b>	<b>Default</b>	<b>Description</b>
<seq_number>	1 to 1,000	Numeric (integer only)	1	Programs the sync pulse to a required position along the sequence table steps.

#### **Response**

The 81180A will return an integer number depending on the current sync lock setting.

### 4.12.9 Modulated Waveforms Global Control Commands

**Modulated Waveforms Global Control Commands** This group is used to set up the instrument in modulated waveforms mode and to select the general parameters that control all modulation functions. Note that the modulation can be turned off to create continuous carrier waveforms (CW). The following modulation schemes can be selected and controlled: AM, FM and Sweep. The modulated waveforms global control commands are summarized in *Table 4-10*. Factory defaults after \*RST are shown in the Default column. Parameter range and low and high limits are listed, where applicable.

**Table 4-10: Modulated Waveforms Global Commands**

Keyword	Parameter Form	Default	Notes
[[:SOURce]			
:MODulation			
:TYPE	OFF   AM   FM   SWEEp	OFF	
:CARRier			
[[:FREQuency]	10e3 to 250e6	1e6	
:FUNction	SINusoid   TRlangle   SQUare	SIN	

#### **MODulation:TYPE{OFF | AM | FM | SWEEp}(?)**

##### **Description**

This command selects the modulation type. All modulation types are internal, so external signals are not required for producing modulation.

##### **Parameters**

Name	Type	Default	Description
OFF	Discrete	OFF	Modulation off is a special mode where the output generates continuous, non-modulated sinusoidal carrier waveforms (CW).
AM	Discrete		This turns on the AM function. Program the AM parameters to fine-tune the function for your application.
FM	Discrete		This turns on the FM function. Program the FM parameters to fine-tune the function for your application.
SWEEp	Discrete		This turns on the sweep function. Program the sweep parameters to fine-tune the function for your application.

##### **Response**

The 81180A will return OFF, AM, FM, or SWE depending on the present modulation type setting.

### **MODulation:CARRier<frequency>(?)**

#### **Description**

This command programs the CW frequency. Note that the CW waveform is sine only and its frequency setting is separate from the standard sine waveform. The CW frequency setting is valid for all modulation types.

#### **Parameters**

<b>Name</b>	<b>Range</b>	<b>Type</b>	<b>Default</b>	<b>Description</b>
<frequen cy>	10e3 to 250e6	Numeric	1e6	Programs the frequency of the carrier waveform in units of Hz. Note that the CW waveform is sine only and its frequency setting is separate from the standard sine waveform.

#### **Response**

The 81180A will return the current carrier frequency value.

### **MODulation:CARRier:FUNCTion(SINusoid | TRIangle | SQUare){?}**

#### **Description**

This specifies the carrier function. There are three functions that can be modulated: Sine, Triangle and Square. The sine, triangle and the square are computed and placed in the memory as complete waveforms and the modulation schemes are computed and replayed as arbitrary waveforms.

#### **Parameters**

<b>Name</b>	<b>Type</b>	<b>Default</b>	<b>Description</b>
SINusoid	Discrete	SIN	Selects sine as the modulated waveform
TRIangle	Discrete		Selects triangle as the modulated waveform
SQUare	Discrete		Selects square as the modulated waveform

#### **Response**

The 81180A will return SIN, TRI, or SQU depending on the selected waveform setting.

## **4.12.10 Modulation Control Commands**

### **Modulation Control Commands**

This group is used to control parameters for individual modulation schemes. Control parameters are available for: AM, FM and Sweep. The modulation control commands are summarized in *Table 4-11*. Factory defaults after \*RST are shown in the Default column. Parameter range and low and high limits are listed, where applicable.

---

Table 4-11: Modulated Waveforms Control Commands

Keyword	Parameter Form	Default	Notes
:AM			
:FUNction			
:SHApe	SINusoid   TRiangle   SQUare   RAMP	SIN	
:INTernal			
:FREQuency	100 to 1e6	1e3	Maximum Carrier to internal freq ration is 1e6
:DEPTH	0 to 100	50	
:FM			
:DEVIation	10.0e-3 to 100e6	100e3	
:FUNction			
:SHApe	SINusoid   TRiangle   SQUare   RAMP	SIN	
:FREQuency	10e-3 to 350e3	10e3	
:MARKer			
[ :FREQuency ]	10e3 to 250e6	505e3	
:SWEep			
:FREQuency			
[ :START ]	10e3 to 250e6	10e3	
:STOP	10e3 to 250e6	1e6	
:TIME	1.4e-6 to 40.0	1e-3	
:DIRection	UP   DOWN	UP	
:SPACing	LINear   LOGarithmic	LIN	
:MARKer			
[ :FREQuency ]	10e3 to 250e6	505e3	

#### 4.12.11 AM Programming

**AM Programming** Use the following command for programming the AM parameters. AM control is internal. The commands for programming the amplitude modulation function are described below. Note that the carrier waveform frequency (CW) setting is common to all modulation schemes.

---

### **AM:FUNCtion:SHAPE(SINusoid | TRIangle | SQUare | RAMP){?}**

#### **Description**

This command will select one of the waveform shapes as the active modulating waveform.

#### **Parameters**

<b>Name</b>	<b>Type</b>	<b>Default</b>	<b>Description</b>
SINusoid	Discrete	SIN	Selects the sine shape as the modulating waveform
TRIangle	Discrete		Selects the triangular shape as the modulating waveform
SQUare	Discrete		Selects the square shape as the modulating waveform
RAMP	Discrete		Selects the ramp shape as the modulating waveform

#### **Response**

The 81180A will return SIN, TRI, SQU, or RAMP depending on the selected function shape setting.

### **AM:INTernal:FREQuency<am\_freq>(?)**

#### **Description**

This command will set the modulating wave frequency for the built-in standard modulating waveform library.

#### **Parameters**

<b>Name</b>	<b>Range</b>	<b>Type</b>	<b>Default</b>	<b>Description</b>
<am_freq>	100 to 1e6	Numeric	1e3	Programs the frequency of the modulating waveform in units of Hz. The frequency of the built-in standard modulating waveforms only is affected. Note that maximum carrier-to-internal-frequency-ratio is 1e6.

#### **Response**

The 81180A will return the present modulating waveform frequency value. The returned value will be in standard scientific format (for example: 100kHz would be returned as 100e3 – positive numbers are unsigned).

### **AM:DEPth<depth>(?)**

#### **Description**

This command will set the modulating wave frequency for the built-in standard modulating waveform library.

#### **Parameters**

<b>Name</b>	<b>Range</b>	<b>Type</b>	<b>Default</b>	<b>Description</b>
<depth>	0 to 100	Numeric	50	Programs the depth of the modulating waveform in units of percent.

#### **Response**

The 81180A will return the present modulating depth value.

---

### 4.12.12 FM Programming

**FM Programming** Use the following command for programming the FM parameters. FM control is internal. There are two types of waveforms that can be used as the modulating waveforms: Standard and Arbitrary. The standard waveforms are built in a library of waveforms and can be used anytime, without external control.

---

#### **FM:DEVIation<deviation>(?)**

##### **Description**

This programs the deviation range around the carrier frequency. The deviation range is always symmetrical about the carrier frequency. If you need a non-symmetrical deviation range, you can use the arbitrary FM composer screen or an external utility to design these types of waveforms.

##### **Parameters**

<b>Name</b>	<b>Range</b>	<b>Type</b>	<b>Default</b>	<b>Description</b>
<deviation >	10e-3 to 100e6	Numeric	100e3	Programs the deviation range around the carrier frequency in units of Hz.

##### **Response**

The 81180A will return the present deviation frequency value. The returned value will be in standard scientific format (for example: 100mHz would be returned as 100e-3 – positive numbers are unsigned).

#### **FM:FUNction:SHAPE(SINusoid | TRIangle | SQUare | RAMP){?}**

##### **Description**

This command will select one of the waveform shapes as the active modulating waveform.

##### **Parameters**

<b>Name</b>	<b>Type</b>	<b>Default</b>	<b>Description</b>
SINusoid	Discrete	SIN	Selects the sine shape as the modulating waveform
TRIangle	Discrete		Selects the triangular shape as the modulating waveform
SQUare	Discrete		Selects the square shape as the modulating waveform
RAMP	Discrete		Selects the ramp shape as the modulating waveform

##### **Response**

The 81180A will return SIN, TRI, SQU, or RAMP depending on the selected function shape setting.

#### **FM:FREQuency<fm\_freq>(?)**

##### **Description**

This command will set the modulating wave frequency for the built-in standard modulating waveform library.

### Parameters

Name	Range	Type	Default	Description
<fm_freq	10e-3 to 350e3	Numeric	10e3	Programs the frequency of the modulating waveform in units of Hz. Only the frequency of the built-in standard modulating waveforms is affected.

### Response

The 81180A will return the present modulating waveform frequency value. The returned value will be in standard scientific format (for example: 100mHz would be returned as 100e-3 – positive numbers are unsigned).

### FM:MARKer<frequency>(?)

#### Description

This function programs marker frequency position. An FM marker can be placed inside the following range: (carrier frequency  $\pm$  deviation frequency / 2). The marker pulse is output from the SYNC output connector.

#### Parameters

Name	Range	Type	Default	Description
<frequency	10e3 to 250e6	Numeric	505e3	Programs the marker frequency position in units of Hz.

### Response

The 81180A returns the present marker frequency value. The returned value will be in standard scientific format (for example: 100mHz would be returned as 100e-3 – positive numbers are unsigned).

## 4.12.13 Sweep Modulation Programming

### Sweep Modulation Programming

Use the following command for programming the sweep parameters. Sweep control is internal. The frequency will sweep from start to stop frequencies at an interval determined by the sweep time value and controlled by a step type determined by the sweep step parameter. There are two sweep modes: Linear, where the step of the generator increments from start-to-stop frequency is linear; and Logarithmic, where the step of the generator increments from start- to-stop frequency is logarithmic. The commands for programming the frequency sweep function are described below.

---

### SWEep:FREQuency<start\_freq>(?)

#### Description

This specifies the sweep start frequency. The 81180A will normally sweep from start-to-stop



frequencies. However, if the sweep direction is reversed, the output will sweep from stop-to-start frequencies. The start-and-stop frequencies may be programmed freely throughout the frequency of the standard waveform frequency range.

#### Parameters

Name	Range	Type	Default	Description
<start_fre q>	10e3 to 250e6	Numeric	10e3	Programs the sweep start frequency. Sweep start is programmed in units of Hz.

#### Response

The 81180A will return the present sweep start frequency value. The returned value will be in standard scientific format (for example: 100mHz would be returned as 100e-3 – positive numbers are unsigned).

### **SWEep:FREQuency:STOP<stop\_freq>(?)**

#### Description

This specifies the sweep stop frequency. The 81180A will normally sweep from start-to-stop frequencies. However, if the sweep direction is reversed, the output will sweep from stop-to-start frequencies. The start-and-stop frequencies may be programmed freely throughout the frequency of the standard waveform frequency range.

#### Parameters

Name	Range	Type	Default	Description
<stop_fre q>	10e3 to 250e6	Numeric	1e6	Programs the sweep stop frequency. Sweep stop is programmed in units of Hz.

#### Response

The 81180A will return the present sweep stop frequency value. The returned value will be in standard scientific format (for example: 100mHz would be returned as 100e-3 – positive numbers are unsigned).

### **SWEep:TIMe<time>(?)**

#### Description

This specifies the time that will take the 81180A to sweep from start-to-stop frequencies. The time does not depend on the sweep boundaries, as it is automatically adjusted by the software to the required interval. At the end of the sweep cycle, the output waveform maintains the sweep stop frequency setting, except if the 81180A is in continuous run mode, where the sweep repeats itself continuously.

#### Parameters

Name	Range	Type	Default	Description
<time>	1.4e-6 to 40	Numeric	1e-3	Programs the sweep time. Sweep time is programmed in units of s.

#### Response

The 81180A will return the present sweep time. The returned value will be in standard scientific format (for example: 100ms would be returned as 100e-3 – positive numbers are unsigned).

### **SWEp:DIRrection(UP | DOWN){?}**

#### **Description**

This specifies if the 81180A output will sweep from start-to-stop (UP) or from stop-to-start (DOWN) frequencies. Sweep time does not affect the sweep direction and frequency limits. At the end of the sweep cycle, the output waveform normally maintains the sweep stop frequency setting, but will maintain the start frequency if the DOWN option is selected, except if the 81180A is in continuous run mode where the sweep repeats itself continuously.

#### **Parameters**

<b>Name</b>	<b>Type</b>	<b>Default</b>	<b>Description</b>
UP	Discrete	UP	Selects the sweep up direction
DOWN	Discrete		Select the sweep down direction

#### **Response**

The 81180A will return UP, or DOWN depending on the selected direction setting.

### **SWEp:SPACing(LINear | LOGarithmic){?}**

#### **Description**

This specifies the sweep step type. Two options are available: logarithmic or linear. In linear, the incremental steps between the frequencies are uniform throughout the sweep range. Logarithmic type defines logarithmic spacing throughout the sweep start and stop settings.

#### **Parameters**

<b>Name</b>	<b>Type</b>	<b>Default</b>	<b>Description</b>
LINear	Discrete	LIN	Selects the linear sweep spacing
LOGarithmic	Discrete		Select the logarithmic sweep spacing

#### **Response**

The 81180A will return LIN or LOG, depending on the selected spacing setting.

### **SWEp:MARKer<frequency>{?}**

#### **Description**

This function programs marker frequency position. Sweep marker can be placed in between the start and the stop frequencies. The marker pulse is output from the SYNC output connector.

#### **Parameters**

<b>Name</b>	<b>Range</b>	<b>Type</b>	<b>Default</b>	<b>Description</b>
<frequency>	10e3 to 250e6	Numeric	505e3	Programs the marker frequency position in units of Hz.

#### **Response**

The 81180A will return the present marker frequency value. The returned value will be in standard scientific format (for example: 100mHz would be returned as 100e-3 – positive numbers are unsigned).

---

#### 4.12.14 Pulse Waveform Programming

##### Pulse Waveform Programming

Use the following commands for programming pulse waveforms and pulse parameters. The pulse is created digitally. However, it closely simulates an analog pulse generator, so pulse parameters are programmed just as they would be programmed on a dedicated pulse generator instrument. Just keep in mind that since this is a digital instrument, there are some limitations to the pulse design that evolve from the fact that the best resolution is one sample clock interval. Also, remember that the pulse is created digitally in the arbitrary memory and therefore, its smallest incremental step has a maximum value limitation as specified in Appendix A. *Figure 4-7* through *Figure 4-9* show how the pulse commands affect the shape of the pulse when placed in Single, Delayed and Double pulse modes. The pulse commands are summarized in *Table 4-12*.

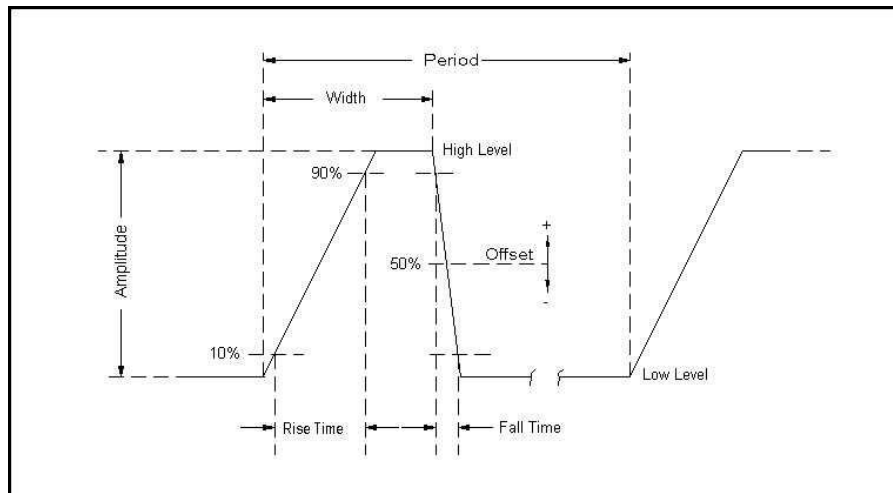

**Figure 4-7: Single Pulse Parameters**

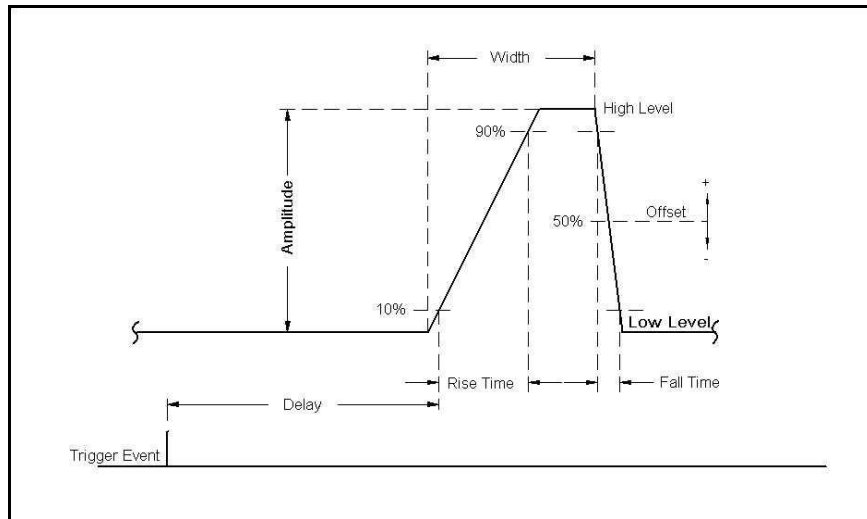

**Figure 4-8: Delayed Pulse Parameters**

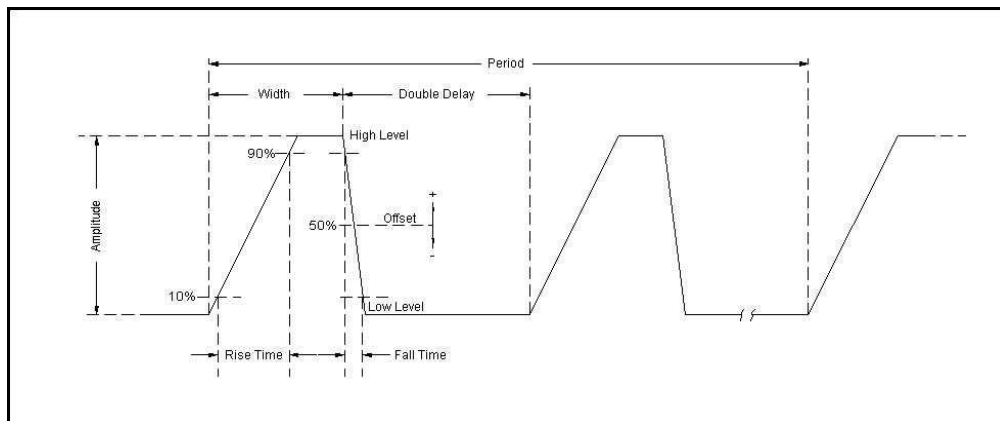

**Figure 4-9: Double Pulse Parameters**

Table 4-12: Pulse Waveform Commands Summary

Keyword	Parameter Form	Default	Notes
:PULSe			
:CONFigure	TIME   PERCent	TIME	
:DELay	0, 1e-9 to 1s	0	Delay in sec
:PERCent	0 .01 to 99.99	10	Delay in %
:DOUBle			
:DELay	1e-9 to 1s	1e-3	Double delay in sec
:PERCent	0 .01 to 99.99	10	Delay in %
:LEVel			
[[:CONTRol]	HLOW   AOFFset   POSitive   NEGative	HLOW	
:HIGH	-2.450 to 2.5	1	
:LOW	-2.5 to 2.450	0	
:AMPLitude	50e-3 to 2   MINimum   MAXimum	0.5	Amplitude in V
:OFFSet	-1.5 to 1.5   MINimum   MAXimum	0	DC offset in volts
:MODE	SINGle   DELayed   DOUBle	SING	
:POLarity	NORMal   COMPlément   INVerted	NORM	
:PERiod	80e-9 to 1e6 (80e-9 to 2e6 with option -264)	10e-3	
:TRANsition			
[[:STATe]	FAST   LINear   SYMMetrical	FAST	Transition mode
[[:LEADing]	1e-9 to 100e-3	1e-3	Rise time in sec
:PERCent	0 .01 to 99.99	10	Rise time in %
:TRAiling	1e-9 to 100e-3	1e-3	Fall time in sec
:PERCent	0 .01 to 99.99	10	Fall time in %
:WIDTh	1e-9 to 1s	2e-3	Width in sec
:PERCent	0 .01 to 99.99	20	Width in %

**PULSE:CONFigure{TIME | PERCent}{?}****Description**

In applications where an absolute setting of a certain pulse parameter is required, it is recommended to select the time option. This means that the parameter can be programmed individually in units of time and will retain the programmed value, regardless of the pulse period setting. The percent option is useful for applications that require a certain relationship between the period and the individual parameter, such as width-to-period or rise-time-to-period. Use this command to configure the generator for one of these options.

**Parameters**

Name	Type	Default	Description
TIME	Discrete	TIME	Enables the programming of pulse parameters in units of time (seconds)
PERCent	Discrete		Enables the programming of certain pulse parameters in units of percent. The ratio is computed in reference to the period frequency. For example, if the period is set to 100 ms and the width is programmed to 10%, the width

will remain 10% of the programmed period, (10 ms in this example) but will be automatically adjusted to 15 ms if the period is changed to 150 ms.

**Response**

The 81180A will return TIME or PERC depending on the present pulse configuration setting.

**PULSe:DELaY<delay>(?)**

**Description**

This command programs the delayed interval of which the output idles on the low level, until the first transition to high level. The delay is measured from the trigger transition to the first pulse transition. Note that this delay does not include the system delay error that is specified in Appendix A. Also note that the only case where the delay can exceed the value of the period setting is in triggered mode, where the external trigger intervals determine the period of the pulse.

**Parameters**

Name	Range	Type	Default	Description
<delay>	0, 1e-9 to 1	Numeric	0	Will set the delay time interval in units of seconds. As shown in <i>Figure 4-2</i> , the delay is measured from trigger transition to the first pulse transition. Puls:del 0 implies that delay is off.

**Response**

The 81180A will return the pulse delay value in units of seconds.

**PULSe:DELaY:PERCent<delay>(?)**

**Description**

This command will program the delayed interval of which the output idles on the low level, until the first transition to high level. The delay is measured from the first external trigger transition to the first pulse transition. Note that this delay does not include the system delay error (200 sample clock periods + 50 ns, typical trigger input to analog output). Also note that the only case where the delay can exceed the value of the period setting is in triggered mode, where the external trigger intervals determine the period of the pulse.

**Parameters**

Name	Range	Type	Default	Description
<delay>	0.01 to 99.99	Numeric	10	Will set the delay time interval in units of percent. As shown in <i>Figure 4-2</i> , the delay is measured from trigger transition to the first pulse transition.

**Response**

The 81180A will return the pulse delay value in units of %.

**PULSe:DOUBLE:DElay<delay>(?)****Description**

This command will program the delay between two adjacent pulses when the double mode is selected. Otherwise, the double pulse delay has no effect on the pulse structure. Note that the only case where the delay can exceed the value of the period setting is in triggered mode, where the trigger interval determines the period of the pulse. Double pulse building block parameters are shown in *Figure 4-3*.

**Parameters**

Name	Range	Type	Default	Description
<delay>	0 to 10	Numeric	200e-6	Will set the delay between two adjacent pulses for the double pulse mode only. The delay is programmed in units of seconds and is measured from the last transition of the first pulse to the first transition of the second pulse.

**Response**

The 81180A will return the present double pulse delay value in units of seconds.

**PULSe:DOUBLE:DElay:PERCent<delay>(?)****Description**

This command will program the delay between two adjacent pulses when the double mode is selected. Otherwise, the double pulse delay has no effect on the pulse structure. Note that the only case where the delay can exceed the value of the period setting is in triggered mode, where the trigger interval determines the period of the pulse. Double pulse building block parameters are shown in *Figure 4-3*.

**Parameters**

Name	Range	Type	Default	Description
<delay>	0.01 to 99.99	Numeric	10	Will set the delay between two adjacent pulses for the double pulse mode only. The delay is programmed in units of percent and is measured from the last transition of the first pulse to the first transition of the second pulse.

**Response**

The 81180A will return the present double pulse delay value in units of percent.

**PULSe:LEVel{HLOW | AOFFset | POSitive | NEGative} (?)****Description**

This command will determine how the pulse levels are programmed. Pulse level mode options are: High/Low, Amplitude/Offset, Positive and Negative.

**Parameters**

Name	Type	Default	Description
HLOW	Discrete	HLOW	Programs pulse level using high level and low level parameters.

AOFFset	Discrete	Programs pulse level using the amplitude and offset parameters. When the offset is left at 0 V settings (default), amplitude changes modifies the pulse level symmetrically about the 0 V level.
POSitive	Discrete	Programs pulse level using the high level parameters. The low level remains at 0 V at all times.
NEGative	Discrete	Programs pulse level using the low level parameters. The high level remains at 0 V at all times.

**Response**

The 81180A will return HOLW, AOFF, POS or NEG depending on the present pulse level mode setting.

**PULSe:LEVel:HIGH<high\_level>(?)**

**Description**

This command programs the high level amplitude of the pulse waveform. The high level is calibrated when the load impedance is 50 Ω.

**Parameters**

Name	Range	Type	Default	Description
<high_lev el>	-2.450 to 2.500	Numeric	1	Will set the high level of the pulse waveform in units of volts.

**Response**

The 81180A will return the present high-level value. The returned value will be in standard scientific format (for example: 100mV would be returned as 100e-3 – positive numbers are unsigned).

**PULSe:LEVel:LOW<low\_level>(?)**

**Description**

This command programs the low level amplitude of the pulse waveform. The low level is calibrated when the load impedance is 50 Ω.

**Parameters**

Name	Range	Type	Default	Description
<low_lev l>	-2.500 to 2.450	Numeric	0	Will set the low level of the pulse waveform in units of volts.

**Response**

The 81180A will return the present low-level value. The returned value will be in standard scientific format (for example: 100mV would be returned as 100e-3 – positive numbers are unsigned).

**PULSe:LEVel:AMPLitude{<ampl> | MINimum | MAXimum}(?)**

**Description**

This command programs the peak-to-peak amplitude of the pulse waveform. The amplitude is calibrated when the source impedance is 50 Ω. Note that this value is a duplication of the volt:ampl parameter and therefore, modifying this parameter in the pulse menu will automatically modify the amplitude setting for the other instrument functions.



**Parameters**

Name	Range	Type	Default	Description
<ampl>	50e-3 to 2	Numeric	0.5	Will set the amplitude of the pulse waveform in units of volts. Amplitude setting is always peak-to-peak. Offset and amplitude settings are independent, providing that the offset + amplitude do not exceed the amplitude window, as specified in Appendix A.
<MINimum um>		Discrete		Will set the amplitude to the lowest possible amplitude (50e-3).
<MAXimum um>		Discrete		Will set the amplitude to the highest possible amplitude level (2).

**Response**

The 81180A will return the present pulse amplitude value. The returned value will be in standard scientific format (for example: 100mV would be returned as 100e-3 – positive numbers are unsigned).

**PULSE:LEVEL:OFFSET{<offs> | MINimum | MAXimum}(?)****Description**

This command programs the offset amplitude of the pulse waveform. The offset is calibrated when the source impedance is 50Ω. Note that this value is a duplication of the volt:offs parameter and therefore, modifying this parameter in the pulse menu will automatically modify the offset setting for the other instrument functions.

**Parameters**

Name	Range	Type	Default	Description
<offs>	-1.5 to 1.5	Numeric	0	Will set the offset of the pulse waveform in units of volts. Offset and amplitude settings are independent providing that the offset + amplitude do not exceed the specified window.
<MINimum um>		Discrete		Will set the amplitude to the lowest possible offset (-1.5).
<MAXimum um>		Discrete		Will set the amplitude to the highest possible offset level (1.5).

**Response**

The 81180A will return the present pulse offset value. The returned value will be in standard scientific format (for example: 100mV would be returned as 100e-3 – positive numbers are unsigned).

**PULSE:MODE{SINGLE | DELAYed | DOUBLE}(?)****Description**

This command will program the mode of the pulse. Pulse mode options are: Single pulse, Delayed pulse and Double pulse. These modes are depicted in *Figure 4-7* thru *Figure 4-9*.

**Parameters**

Name	Type	Default	Description
SINGLE	Discrete	SING	Programs single pulse output, which generates normal pulses

DElAged	Discrete	Programs a delayed pulse mode, which generates normal pulses that are delayed from the SYNC output
DOUBle	Discrete	Programs a double pulse mode, which generates a pair of single pulses that are displaced by a double delay period

**Response**

The 81180A will return SING, DEL or DOUB depending on the present pulse mode setting.

**PULSe:POLarity{NORMal | COMPlément | INVerted}(?)**

**Description**

This command will program the polarity of the pulse in reference to the baseline level. The polarity options are: Normal - where the pulse is generated exactly as programmed, Inverted - where the pulse is inverted about the 0 level base line and Complemented - where the pulse is inverted about its mid-amplitude axis.

**Parameters**

Name	Type	Default	Description
NORMal	Discrete	NORM	Programs normal pulse output
COMPlément	Discrete		Programs complemented pulse output
INVerted	Discrete		Programs an inverted pulse output

**Response**

The 81180A will return NORM, COMP or INV depending on the present polarity setting.

**PULSe:PERiod<period>(?)**

**Description**

This command will program the pulse repetition rate (period). Note that with the sum of all parameters, including the pulse width and fall time cannot exceed the programmed pulse period and therefore, it is recommended that the pulse period be programmed first, before all other pulse parameters. Note that by selecting the double pulse mode, the pulse period remains unchanged.

**Parameters**

Name	Range	Type	Default	Description
<period>	80e-9 to 1e6 (80e-9 to 2e6 with option -264)	Numeric	10e-3	Programs the period of the pulse waveform in units of seconds.

**Response**

The 81180A will return the present pulse period value in units of seconds.

**PULSe:TRANSition:STATe{FAST | LINear | SYMMetrical} (?)**

**Description**

This command will place the pulse output in one of three transition options: 1) Fast - the level transitions from high-to-low or low-to-high at the fastest rate that the generator can produce 2) Linear - the level transitions linearly at a programmed rate from low-to-high and from high-to-low and

each transition can be programmed to a different rate and 3) Symmetrical - the leading and trailing edges transition exactly at the same rate.

**Parameters**

Name	Type	Default	Description
FAST	Discrete	FAST	Programs the fast transitions mode. In this mode, the leading and trailing edges will transition as fast as the instrument allows.
LINear	Discrete		Selects linear transitions. Note that unlike analog pulse generators, the 81180A can be programmed freely within the specified boundaries, without the limitation of transition ranges commonly attributed to analog pulse generators.
SYMMertical	Discrete		Programs a special mode where the transitions are symmetrical for both the leading and trailing edges (lead time = trail time). In this case, the value of the lead-time is automatically attributed to the trail time and the value of the trail time has no effect on the pulse shape.

**Response**

The 81180A will return FAST, LIN or SYMM depending on the present transition mode setting.

**PULSe:TRANSition<I\_edge>(?)**

**Description**

This command will program the interval it will take the leading edge of the pulse to transition from its low- to high-level settings. The parameter is programmed in units of seconds. Unlike analog pulse generators, the 81180A can be programmed freely within the specified boundaries, without the limitation of transition ranges that are commonly attributed to analog pulse generators. Note that this parameter will affect the instrument only when the pulse transition mode is set to linear.

**Parameters**

Name	Range	Type	Default	Description
<I_ed ge>	1e-9 to 100e-3	Numeric	1e-3	Will set the leading-edge transition time parameter in units of seconds. Note that the sum of all parameters, including transition times, must not exceed the programmed pulse period.

**Response**

The 81180A will return the present leading-edge transition time value in units of seconds.

**PULSe:TRANSition:PERCent<I\_edge>(?)**

**Description**

This command will program the interval it will take the leading edge of the pulse to transition from its low- to high-level settings. The parameter is programmed in units of percent of the pulse period. Note that this parameter will affect the instrument only when the pulse transition mode is set to linear and when the pulse configuration is programmed to percent.

### Parameters

Name	Range	Type	Default	Description
<l_ed	0.01 to 99.99	Numeric	10	Will set the leading-edge transition time parameter in units of %. Note that the sum of all parameters, including transition times must not exceed 100%.

### Response

The 81180A will return the present leading-edge transition time value in units of %.

### PULSe:TRANSition:TRAILing<t\_edge>(?)

#### Description

This command will program the interval it will take the trailing edge of the pulse to transition from its high- to low-level settings. The parameter is programmed in units of seconds. Unlike analog pulse generators, the 81180A can be programmed freely within the specified boundaries, without the limitation of transition ranges that are commonly attributed to analog pulse generators. Note that this parameter will affect the instrument only when the pulse transition mode is set to linear.

### Parameters

Name	Range	Type	Default	Description
<T_e	1e-9 to 100e-3	Numeric	1e-3	Will set the trailing-edge transition time parameter in units of seconds. Note that the sum of all parameters, including transition times, must not exceed the programmed pulse period.

### Response

The 81180A will return the present trailing edge transition time value in units of seconds.

### PULSe:TRANSition:TRAILing:PERCent<t\_edge>(?)

#### Description

This command will program the interval it will take the trailing edge of the pulse to transition from its high- to low-level settings. The parameter is programmed in units of percentages of the pulse period. Note that this parameter will affect the instrument only when the pulse transition mode is set to linear and when the pulse configuration is programmed to percent.

### Parameters

Name	Range	Type	Default	Description
<l_ed	0.01 to 99.99	Numeric	10	Will set the trailing-edge transition time parameter in units of %. Note that the sum of all parameters, including transition times, must not exceed 100%.

### Response

The 81180A will return the present leading edge transition time value in units of %.

### PULSe:WIDth<width>(?)

#### Description

This command will program the pulse width value. *Figure 4-7* thru *Figure 4-9* shows how the pulse

width affects the shape of the pulse. Note that the only case where the pulse width can exceed the value of the period setting is in triggered mode, where the trigger determines the period of the pulse.

#### Parameters

Name	Range	Type	Default	Description
<width >	1e-9 to 1	Numeric	2e-3	Will set the width of pulse in units of seconds. Note that the sum of all parameters, including the pulse width, must not exceed the programmed pulse period.

#### Response

The 81180A will return the present pulse width value in units of seconds

#### PULSe:WIDTh:PERCent<width>(?)

##### Description

This command will program the pulse width value. *Figure 4-7* thru *Figure 4-9* shows how the pulse width affects the shape of the pulse. Note that this parameter will affect the instrument only when the pulse transition mode is set to linear and when the pulse configuration is programmed to percent.

##### Parameters

Name	Range	Type	Default	Description
<le >	0.01 to 99.99	Numeric	20	Will set the pulse width parameter in units of %. Note that the sum of all parameters, including transition times, must not exceed 100%.

#### Response

The 81180A will return the present leading edge transition time value in units of %.

## 4.12.15 LAN System Configuration Commands

**LAN System Configuration Commands** Use these commands to configure IP addresses and other LAN parameters. It is strongly recommended that this be done with a computer specialist, because incorrect programming may place the instrument in an unknown configuration which will not communicate as expected with the network. The LAN commands are summarized in *Table 4-13*.



Last LAN configuration settings will remain as long as the instrument is turned on. New LAN configuration settings will take effect only after the instrument has been powered off and on.

**Table 4-13: LAN Commands Summary**

Keyword	Parameter Form	Default	Notes
:SYSTem			
:IP			
[:ADDRess]	<IP_address>		
:MASK	<mask>		
:GATeway	<gate_way>		
:BOOTp	OFF   ON   0   1	0	
HOSTname:	<host_name>		
:KEEPAlive			
:STATe	OFF   ON   0   1	1	
:TIMEout	2 to 300	45	
:PROBES	2 to 10	2	

**SYSTem:IP<ip\_adrs>(?)**

**Description**

This command programs the IP address for LAN operation. The same command is performed from the front panel Utility -> Remote Interface -> LAN menu. Note that after you use this command the power to the 81180A must be recycled before the new address takes precedence.

**Parameters**

Name	Range	Type	Description
<ip_adrs>	0 to 255	String	Programs the IP address for LAN operation. The current IP address can be observed on the TCP/IP Network Properties display.

**Response**

The 81180A will return the present IP address value similar to the following: 192.168.0.245

**SYSTem:IP:MASK<mask\_adrs>(?)**

**Description**

This command programs the subnet mask address for LAN operation. The programming is performed from the front panel Utility -> Remote Interface -> LAN menu.

**Parameters**

Name	Range	Type	Description
<mask_adrs >	0 to 255	String	Programs the subnet mask address for LAN operation. Programming must be performed from the front panel. The current IP address can be observed on the TCP/IP Network Properties display.

**Response**

The 81180A will return the present IP address value similar to the following: 255.255.255.0

**SYSTem:IP:BOOTp{OFF|ON|0|1}(?)****Description**

Use this command to toggle BOOTP mode on and off.

**Parameters**

Range	Type	Default	Description
0-1	Discrete	0	Toggles BOOTP mode on and off. When on, the IP address is administrated automatically by the system.

**Response**

The 81180A will return 0 or 1, depending on the present BOOTP setting.

**SYSTem:IP:GATeway<gate\_adrs>(?)****Description**

This command programs the gateway address for LAN operation. The programming is performed from the front panel Utility -> Remote Interface -> LAN menu.

**Parameters**

Name	Range	Type	Description
<gate_adrs>	0 to 255	String	Programs the gateway address for LAN operation. Programming must be performed from the front panel. The current IP address can be observed on the TCP/IP Network Properties display.

**Response**

The 81180A will return the present IP address value similar to the following: 0.0.0.0

**SYSTem:IP:HOSTname<name>(?)****Description**

This command programs the host name address for LAN operation. The programming is performed in the factory and it is highly suggested that users do not change the host name without first consulting an Agilent customer service person.

**Parameters**

Name	Type	Description
<name>	String	Programs the host name for LAN operation.

**Response**

The 81180A will return a string containing the host name. String length is 16 characters.

**SYSTem:IP:KEEPalive:STATe{OFF|ON|0|1}(?)****Description**

Use this command to toggle the keep-alive mode on and off. The keep-alive mode assures that LAN connection remains uninterrupted throughout the duration of the LAN interfacing.

### Parameters

Range	Type	Default	Description
0-1	Discrete	1	Toggles the keep-alive mode on and off. When on, the 81180A constantly checks for smooth LAN connection at intervals programmed by the <code>syst:keep:time</code> command. The LAN will be probed as many times as programmed by <code>syst:keep:prob</code> parameter to check if there is an interruption in the LAN communication. When communication fails, the 81180A reverts automatically to local (front panel) operation.

### Response

The 81180A will return 0 or 1, depending on the present keep-alive setting.

### **SYSTem:IP:KEEPalive:TIMEout<time\_out>(?)**

#### Description

This command programs the keep-alive time-out. The keep-alive mode assures that LAN connection remains uninterrupted throughout the duration of the LAN interfacing.

#### Parameters

Name	Range	Type	Default	Description
<time_out>	2 to 300	Numeric	45	Programs the keep-alive time out in units of seconds. The time-out period is initiated when the LAN is idle for more than the time-out period. The LAN will be probed as many times as programmed by <code>syst:keep:prob</code> parameter to check if there is an interruption in the LAN communication. When communication fails, the 81180A reverts automatically to local (front panel) operation.

### Response

The 81180A will return the present keep-alive time-out value.

### **SYSTem:IP:KEEPalive:PROBes<probes>(?)**

#### Description

This command programs the number of probes that are used by the keep-alive sequence. The keep-alive mode assures that LAN connection remains uninterrupted throughout the duration of the LAN interfacing.

#### Parameters

Name	Range	Type	Default	Description
<probes>	2 to 10	Numeric	2	Programs the number of probes that are used by the keep-alive sequence. The time-out period is initiated when the LAN is idle for more than the time-out period and the LAN will be probed as many times as programmed by this parameter to check if there is an



interruption in the LAN communication. When communication fails, the 81180A reverts automatically to local (front panel) operation.

### Response

The 81180A will return the present keep-alive number of probes.

## 4.12.16 Store/Recall Commands

**Store/Recall Commands** Use these commands to store instrument settings. The store command collects the current front panel setting and parameters and stores them in a dedicated memory cell. The store operation can include front panel settings and current waveforms but, due to memory limitations, you may select to keep settings only without waveforms or waveforms only without settings. The store/recall commands are summarized in *Table 4-14*.

**Table 4-14: Store/Recall Commands Summary**

Keyword	Parameter Form	Default	Notes
:SYSTem			
:STORe			
:CELL	1 to 9		
:CLEar			Clears memory cell
:CONFig	SETup   WAVE   ALL	ALL	
:TARGet	INTernal   USB	INT	
:UPDate			
:RECall			
:CELL	1 to 9		
:TARGet	INTernal   USB	INT	
:UPDate			

### **SYSTEM:STORe:CELL<cell\_number>(?)**

#### Description

This command selects a memory cell. The selected memory cell will become the target for the store operation. You may select to store front panel settings, waveforms or both.

#### Parameters

Name	Range	Type	Description
<cell_number>	1 to 9	Numeric (integer only)	Selects an active memory cell number. Consequent store commands will affect this cell only.

**Response**

The 81180A will return the active memory cell value.

**SYSTem:STORe:CLEAr****Description**

Use this command to clear the content of a specific memory cell. This will prepare the memory cell to accept new setup and waveform data.

**SYSTem:STORe:CONFig{SETup | WAVE | ALL }{?}****Description**

Use this command to select what you intend to store in the active memory cell. The default setting is ALL. If you plan to save anything, make sure that the default setting is changed before you do a cell memory update.

**Parameters**

Name	Type	Default	Description
SETup	Discrete		Selects front-panel configuration to be stored in the active memory cell.
WAVE	Discrete		Selects the current arbitrary waveform to be stored in the active memory cell.
ALL	Discrete	ALL	Will store both front-panel configuration and waveform in the active memory cell.

**Response**

The 81180A will return SET, WAVE, or ALL depending on the present configuration setting.

**SYSTem:STORe:TARGet{INTernal | USB}{?}****Description**

Use this command to select the target of your store operation. You may select between an internal flash memory that is limited in size and disk-on-key flash that you can attach to the front panel input. Selecting the internal option, you may store waveforms up to 100k long but external memory has no limitations except the physical size of the flash on the disk-on-key.

**Parameters**

Name	Type	Default	Description
INTerna l	Discrete	INT	Selects the internal flash memory as the target for the store operation. Waveform size for this option is limited to 100k points.
USB	Discrete		Selects the front panel USB input as the target for the store operation. Waveform size for this option is limited only by the size of the disk-on-key flash.

**Response**

The 81180A will return INT or USB, depending on the present store target setting.

**SYSTem:STORe:UPDate****Description**

Use this command to update the active memory cell with the front panel settings, waveforms, or both.

**SYSTem:RECall:CELL<cell\_number>(?)****Description**

This command selects a memory cell. The selected memory cell will become the source for the recall operation. You may select to recall front panel settings, waveforms, or both.

**Parameters**

Name	Range	Type	Description
<cell_number>	1 to 9	Numeric (integer only)	Selects an active memory cell number. Consequent recall commands will affect this cell only.

**Response**

The 81180A will return the active memory cell value.

**SYSTem:RECall:TARGet{INTernal | USB}(?)****Description**

Use this command to select the source of your recall operation. You may select between an internal flash memory that is limited in size and disk-on-key flash that you can attach to the front panel input. Selecting the internal option, you may recall waveforms up to 100k long, but external memory has no limitations except the physical size of the flash on the disk-on-key.

**Parameters**

Name	Type	Default	Description
INTernal	Discrete	INT	Selects the internal flash memory as the source for the recall operation. Waveform size for this option is limited to 100 k points.
USB	Discrete		Selects the front panel USB input as the source for the recall operation. Waveform size for this option is limited only by the size of the disk-on-key flash.

**Response**

The 81180A will return INT or USB, depending on the present recall source setting.

**SYSTem:RECall:UPDate****Description**

Use this command to update the front panel and arbitrary memory with the information stored in the active memory cell.

## 4.12.17 System Commands

### System Commands

The system-related commands are not related directly to waveform generation but are an important part of operating the 81180A. Use these commands to reset the instrument and query its system settings.

---

**Table 4-15: Store/Recall Commands Summary**

Keyword	Parameter Form	Default
:RESet (*RST)		
:SYSTem		
:ERRor?		
:LOCal		
:VERSion?		
:INFormation		
:CALibration?		
:MODEl?		
:SERial?		
:HARDware?		
:POWerup	DEFault   SETup	DEF
*RST		
*TRG		
*OPC?		
*STB?		
*IDN?		
*OPT?		

### RESet, or \*RST

#### Description

This command will reset the 81180A to its factory defaults.

---

### SYSTEM:ERRor?

#### Description

Query only. This query will interrogate the 81180A for programming errors.

#### Description

The 81180A will return error code. Error messages are listed below.

---

## 4.13 LAN, USB and GPIB Programming Considerations

**LAN, USB and GPIB Programming Considerations** The Model 81180A can be programmed from one of three remote interfaces: LAN, USB and GPIB. These interfaces not only differ by how they mechanically interface to the instrument but also they are very different in the way that the instrument reacts to their commands. For example, the generator does not require any LAN drivers to connect to a host computer but without a proper USB driver installed on the computer, the generator will not link and will not receive commands. There are also hardware issues that differ from interface to interface, for example, there is one standard in the market for the USB interface and driving hardware but, on the other hand, the GPIB standard being developed back in the early 80's of the last decade, triggered competition between vendors that lead to multiple and parallel development of GPIB interfaces and drivers and, by that, although there is one common standard (IEEE-488.2), each of the interfacing hardware reacts a bit different to commands and has its own peculiarities when it comes to timing, response and handshaking principals.

The model 81180A is supplied with IVI.COM driver that has code examples and hence eliminates the need to deal with timing issues that are associated with the different interfaces and more specifically the driver examples already have the proper delays and pauses that are mandatory when using some of the GPIB cards so, if you are using the examples in the supplied driver, you'll probably have no problem whatsoever to control instrument parameters and download waveforms without getting into timing issues that will cause unpredictable behavior of the generator.

When the generator receives waveform coordinates or table data, the amount of data that is being transferred to the instrument is huge and can reach 128,000,000 words of data, if both channels are being written with waveform data. Waveform coordinates are being downloaded using special technique, which is described earlier in the manual so, it is important to remember that, compared to SCPI commands that may take a few milliseconds to program, downloading time of waveforms and table data is in the order of many seconds.

Some of the interfaces are not so forgiving when it comes to such differences in timing, especially when control commands are chained with waveforms and table data and therefore, one must install the proper control and suitable handshake that inhibits the flow of data till the generator is fully ready to accept the next command, query or waveform coordinates.

In general, the model 81180A should always be ready to accept commands but bear in mind that commands are parsed, interpreted by the firmware and then distributed to various registers and internal busses that control the instrument functions. Some of the commands trigger just one event but some commands have to access and set a huge bank of registers. For example, a \*trg command flips one port but \*rst has to access and reset hundreds of registers so, obviously, there will be timing issue if one expects that \*trg and \*rst take the same amount of time to execute.

The bottom line is that one must place proper delays and inhibits before and after each command or data download otherwise, the generator will miss data or generate errors that will interfere with its normal operation.

There is more than one way to delay commands; although undesired, one can place fixed delays in the program. For example, to make sure that the generator is ready to send a response to a query, it is simple to place a delay right after the query and interrogate the response right after the delay has lapsed. Simple but not efficient because, as was explained above, the response of the firmware differs from command to query so setting a general delay for example of 100 ms will be ok for one query but will slow the rest of the process unnecessarily.

A more efficient way to assure that the 81180A is ready for the next command or query is to use the IEEE-488.2 status model. The status model is explained earlier in this manual but, in general, provides status registers that, if queried and dealt with correctly, eliminate unnecessary wait time entirely. In general, the status model is built around a status byte register (STB) that can be programmed to request service when a specific condition is true. For example, it can be programmed to tell you that the output queue is empty and ready for the next command or, it can be programmed to request service when an Operation Complete bit (OPC) has been set true.

The Status Model has been refined over the years and programmers may take advantage of this system when using the Instrument Class of GPIB, USB and LAN interfaces. This new class employs a ReadSTB function that reads the status byte register and is available for all message-based devices. Out of the above three interfaces, the GPIB interface chip is the only device that embeds the STB function as a hardware register so polling the status byte does not interrupt the firmware flow and hence the STB register can be queried continuously until a satisfying response is available. LAN and USB emulate the STB byte using a simulated register and hence, it is not recommended to continuously query the STB but wait till the status byte generates the expected status value.

There is also the problem of timeout. Different programs expect that certain operations do not exceed time limit that is set by the system. Often, programmers set this value vaguely without really investigating what is the real timeout that is required to execute a command and, in some case, when an operation exceeds the programmed time out value, the instruments simply reports that it timed out and the reason is not always obvious to the programmer. Notice in the attached program that the timeout value is modified occasionally to match the require interval that is required to complete the operation safely.

The model 81180A accepts four types of data from any remote interface:

1. Commands that set and program functions and parameters for the various inputs and outputs of the generator;
2. Commands that query current status or generator settings;
3. Data for generating arbitrary waveforms, and
4. Data for tables such as sequences and memory segmentation.

Commands that control instrument functions and parameters are programmed using Standard Commands for Programmable Instruments (SCPI commands). These are normally ASCII characters that are parsed and interpreted and converted by the firmware to control registers and serial trains. Generally, such commands are parsed in just a few milliseconds so command streams flow to the generator with practically no delays. This is true for command streams that do not exceed the input buffer size of 256 characters. However, commands chain that exceeds the size of 256 characters may chock the input buffer and therefore it is recommended that programs use short command strings. For example, one may use the following command string:

```
Inst:sel 1::Func:mode user::trac:def 1,10240::trac:def 2, 20480::trac:def 3,
348::trac:sel 1::volt 1.250;offs -0.350::outp 1::inst:sel 2:: Func:mode
user::trac:def 1,10240::trac:def 2, 20480::trac:def 3, 348::trac:sel 1::volt
1.250;offs -0.350::outp 1
```

Depending on the speed of the computer and the interface that is being used, it is possible that the string will be executed properly however; one should not take the chance because it may cause timeouts and may not be executed properly. Better practice would be to send the commands one at a time or chain just short strings that will not overload the input buffer.

No delays between commands or status interrogation is required when using the following example:

```
Inst:sel 1  
Func:mode user  
trac:def 1,10240;def 2, 20480;def 3, 348; sel 1  
volt 1.250;offs -0.350;;outp 1  
Inst:sel 2  
Func:mode user  
trac:def 1,10240;def 2, 20480;def 3, 348; sel 1  
volt 1.250;offs -0.350;;outp 1
```

So, the recommendation for sending SCPI commands is to keep them short as possible. Also, bear in mind that control commands should not be mixed with waveform data because data is transferred to the generator using special binary format that is routed directly to the arbitrary working memory and hence there is danger that, if interrupted unexpectedly, the transmission will either time out or, in extreme cases will lock out the interface and only power recycling will revive the generator.

An exception to the above recommendation is the \*rst command. This command is usually sent at the beginning of a program to make sure that the instrument is programmed from its default setting. It is possible that a program modified just a few parameters but a hard reset does not care and has to access and process hundreds of settings and therefore the generator is not ready to accept any commands till all of its internal registers were reset. A fixed delay of around 1 to 2 seconds is sufficient to avoid hiccups but, if timing is crucial, it is also possible to use the STB register to discover when the generator has recovered all parameters and is ready for the next set of commands.

Queries which interrogate instrument settings and parameters delay certain interface activities when approaching registers that contain the required information. Depending on the current operation and the priority of certain processes of the generator, it is possible that the generator is inhibiting the response till it completes a critical and more important task so, in this case, it is recommended that the program does not intercept the output with a flow of queries and read cycles that are not critical to the operation of the instrument but wait for the generator to complete its more important tasks first.



The following example demonstrates bad practice when it comes to program and query instrument functions and parameters:

```
Inst:sel 1::Func:mode fix::func:shap squ:: squ:dcyc 30::volt
1.250::volt:offs -0.350::outp 1
Inst:sel?::Func:mode?::func:shap?::squ:dcyc?::volt?::volt:offs?::outp?::sys
t:err?
```

Sending the string of commands in the above example should not be a problem and no delays are necessary between commands however, interrogating the generator continuously and without placing proper pauses may cause timeouts and therefore it is recommended that after each query, the STB register is read to assure that a response is available and only then the response should be read. The following practice is recommended when using multiple queries:

```
*sre16 (enable service request on message available bit - MAV)
Query?
ReadSTB and wait till the response it 16
Read the response to the query
```

The above is recommended as general practice for all queries however, it is up to the programmer do decide if he wants to query parameters that he just programmed or eliminate all and just query the generator for errors only (syst:err?). It is also possible to place fixed delays after each query but this method is less efficient and may accumulate large and unnecessary delays in the program.

Programming the generator with waveform or table data is more of a challenge because there are two parts to this process: 1) the instrument is prepared with ASCII commands to a point where it is ready to receive waveform data and 2) download waveform data.

Sounds similar but, in fact, the two processes are completely different. The commands that prepare the generator for the download process are the same as any control commands; these are simple SCPI commands that select and define the segment number. An example of segment definition is shown below:

```
func:mode user
trac:sel 1
trac:def 1, 2048
```

The above simple example places the generator in arbitrary mode and selects and defines segment 1 to have a size of 2,048 words of waveform data.

The next command that starts the download process is `trac#<data_array>`. As explained earlier in this chapter, this command has two parts: 1) header, that tells the generator how many bytes are expected to be downloaded. The header part is delimited by the character “#” and 2) waveform data. The header is all ASCII but once the “#” is encountered, the generator reverts to binary mode and the CPU interface bus is rerouted to the arbitrary waveform memory so the interface has no control over bus activities till the entire waveform bytes have been transferred to the working memory and only then the CPU re-enables receipt of control commands over the interface.

It is important to understand that interrupting the binary download process while the firmware branched out to loop on the downloaded data, and has no control over interface functions, will cause complete lockout of the interface and only recycling of the power will resume normal operation and therefore, it is recommended and shown in the `C#` example below how to prepare, control, download waveform data and wait for the generator to complete the processes in a way that will not cause timeouts or lockups.

One last recommendation is the use of CR (Carriage Return) and NL (New Line) in the program. As was mentioned before, LAN, USB and GPIB have different requirements, not only by definition of their relevant standard but also in the way that different interface vendors interpret the end of string. IEEE-488.2 standard has specific rules how to terminate a string of commands; the OEI (End or Identify) characters can be selected as hardware or software termination but this was true while the GPIB was used as the main interfacing options. Later arrivals in the interface arena were the USB and LAN of which behave differently than the GPIB interface. It is hard to define common rules for end termination that will uniformly satisfy all interfaces and therefore it is recommended that rules that were designed for the model 81180A be observed while using one or another interfacing channel.

In general, CR character (`\r`) is not required and, in fact, removed from the IEEE-488.2 standard entirely however, if such character is programmed or received by the 81180A, it is ignored. GPIB is the only interface that can be set to accept hardware end of string but is not commonly used by programmers and therefore, the general recommendation for all USB, LAN and GPIB users is to terminate commands with NL character (`\n`) and expect that the end of response from the generator is the NL character (`\n`) as well.

---

**C# Language - Example: Creating and downloading an Arbitrary Waveform**

```

using System;
using System.Collections.Generic;
using System.ComponentModel;
using System.Data;
using System.Drawing;
using System.Linq;
using System.Text;
using System.Windows.Forms;
using System.IO;
using System.Collections.ObjectModel;
using Ivi.Visa.Interop;
using IO488Extensions;

namespace downloadArbitraryWaveform
{
    public partial class Form1 : Form
    {
        ResourceManagerClass rm = new ResourceManagerClass();
        FormattedIO488Class fIO = new FormattedIO488Class();

        public Form1()
        {
            InitializeComponent();
            this.StartPosition = FormStartPosition.CenterScreen;
            textBox1.Text = "GPIB0::5::INSTR";
        }

        private void DownloadWaveformButton_Click(object sender, EventArgs e)
        {
            try
            {
                // Prepare the coordinates of an Arbitrary Waveform (sinewave)
                int iWaveLength = Convert.ToInt32(WaveLengthTextBox.Text);
                Collection<float> dataPoints = calculateSinusoidWaveform
                    (iWaveLength, 1.5, 0);

                // Connect and identify the instrument
                string addressString = textBox1.Text;
                fIO.IO = (IMessage)rm.Open(addressString, AccessMode.NO_LOCK, 0,
                    "Timeout = 10000");

                if (fIO.IO.HardwareInterfaceName == "GPIB" ||
                    fIO.IO.HardwareInterfaceName == "USB")
                {
                    // Enable the MAV bit in the Service Request Enable
                    // Register (SRE)
                    // of IEEE 488.2
                    fIO.WriteString("*CLS;*SRE16\n", true);
                }
                else if (fIO.IO.HardwareInterfaceName == "TCPIP")
                    fIO.IO.TerminationCharacterEnabled = true;

                // Reset the instrument
                fIO.WriteString("*RST\n", true);
            }
        }
    }
}

```

```

// Read the identification string of the discovered instrument
// using the
// QueryString method. This method is extension method for
// FormattedIO488Class
// class and is implemented in the IO488QueryExtension class.
string strDevID = fIO.QueryString("*IDN?\n", true);

fIO.WriteString(":INST:SEL 1", true);
// Set the ARBITRARY mode for channel 1
fIO.WriteString(":FUNC:MODE USER", true);

// Program instrument Parameters

// Program the sample clock frequency
fIO.WriteString(":FREQ:RAST 1.5E+08", true);
// Program the amplitude
fIO.WriteString(":VOLT 2", true);
// Program the offset
fIO.WriteString(":VOLT:OFFS 0", true);
// Delete the segment table
fIO.WriteString(":TRAC:DEL:ALL", true);
// Download the Arbitrary Waveform as binary block
SendDataToInstrument(dataPoints.ToArray(), 1);

fIO.WriteString(":OUTP ON", true);

fIO.IO.Close();
}
catch (Exception ex)
{
    MessageBox.Show(ex.Message);
}
}

private void SendDataToInstrument(float[] fDataPts, int segmentNumber)
{
    // Define a segment
    fIO.WriteString(":TRAC:DEF " + segmentNumber.ToString()
        + "," + fDataPts.Length.ToString(), true);

    // Select the pre-defined segment
    fIO.WriteString(":TRAC:SEL " + segmentNumber.ToString(), true);

    // DAC Values Conversion
    short[] dacValues = new short[fDataPts.Length];

    float fMin = fDataPts.Min();
    float fMax = fDataPts.Max();
    float fDiff = Math.Abs(fMax - fMin);
    byte[] bArray = new byte[fDataPts.Length * sizeof(short)];
    int cnt = 0;

    for (int i = 0; i < fDataPts.Length; i++)
    {
        if (i < fDataPts.Length)
        {
            if (fDiff == 0)
                fDataPts[i] = 0.0f;
            else
                fDataPts[i] = ((fDataPts[i] - fMin)/fDiff * (1 * 2))-1;
        }
    }
}

```

```

        dacValues[i] = (short)Math.Floor((fDataPts[i]*2047)+2048.5);
    }

    else
        dacValues[i] = 2048;

        // Convert DAC Values to Bytes
        byte[] temp = new byte[2];
        temp = BitConverter.GetBytes(dacValues[i]);

        // SWAPPING OF BYTES
        bArray[cnt++] = temp[0];
        bArray[cnt++] = temp[1];
    }

    // Download data (binary block) using the WriteIEEEBlock method.
    // This is an extension method for FormattedIO488Class class and
    // is implemented in the IO488WriteIEEEBlockExtension class

    fIO.WriteIEEEBlock(":TRACe:DATA ", bArray);
}

private Collection<float> calculateSinusoidWaveform(long lPoints,
double dCycles, double dStartPhase)
{
    double omega, phase, cycle;
    Collection<float> dataPoints = new Collection<float>();

    cycle = (double)(lPoints) / dCycles;

    // Calculate the start phase
    phase = (double)((double)(dStartPhase) * Math.PI / (double)180.0);

    // Calculate Omega
    omega = (double)(1.0 / lPoints * Math.PI * 2 * dCycles);

    for (long i = 0; i < lPoints; i++)
        dataPoints.Add((float)Math.Sin((omega * (double)i) + phase));

    return dataPoints;
}
}

using System;
using System.Collections.Generic;
using Ivi.Visa.Interop;

namespace IO488Extensions
{
    public static class IO488QueryExtension
    {
        private const short MAV = 0x10;
        private const long TIMEOUT = 8000; // 8s by default

        /*
         * Query the MAV string
         */
    }
}

```

```

public static string QueryString(this FormattedIO488Class io,
string format, bool flushAndEND)
{
    io.WriteString(format, flushAndEND);

    return ReadString(io, true);
}

/*
 * Read the MAV string
 */
public static string ReadString(this FormattedIO488Class io,
bool CheckMAVBit)
{
    if (CheckMAVBit &&
        (io.IO.HardwareInterfaceName == "GPIB" ||
         io.IO.HardwareInterfaceName == "USB"))
    {
        short stb = 0;
        long endMilliseconds, startMilliseconds = DateTime.Now.Ticks /
        TimeSpan.TicksPerMillisecond;

        do
        {
            endMilliseconds = DateTime.Now.Ticks /
            TimeSpan.TicksPerMillisecond;
            if ((endMilliseconds - startMilliseconds) > TIMEOUT)
                throw new Exception("IO488QueryExtension:
                A timeout occurred");

            stb = io.IO.ReadSTB();
        } while ((stb & MAV) != MAV);
    }

    return io.ReadString();
}

public static class IO488WriteIEEEBlockExtension
{
    private const int CHUNK_LENGTH = 32000;
    private const string OPERATION_COMPLETED = "1";

    /*
     * WriteIEEEBlock
     */
    public static void WriteIEEEBlock(this FormattedIO488Class io,
string Command,
                                     object data)
    {
        if (io.IO.HardwareInterfaceName == "GPIB" ||
            io.IO.HardwareInterfaceName == "USB")
        {
            string answer = io.QueryString("*OPC?\n", true).TrimEnd('\n');
            if (answer.Equals(OPERATION_COMPLETED))
            {
                byte[] BinaryBlock = (byte[])data;

                // Make the binary block prefix
            }
        }
    }
}

```

```

string Digits = String.Format("{0}", BinaryBlock.Length);
byte[] Header = ToByteArray(String.Format("{0} #{1}{2}",
Command, Digits.Length, Digits));

// Write a prefix of binary block to formatted I/O write
// buffer.
if (io.IO.Write(ref Header, Header.Length) == Header.Length)
{
    byte[] Chunk = new byte[CHUNK_LENGTH];
    int Length;

    for (int Start = 0; Start < BinaryBlock.Length;
        Start += Chunk.Length)
    {
        Length = Math.Min(Chunk.Length, BinaryBlock.Length - Start);

        System.Buffer.BlockCopy(BinaryBlock,
            Start, Chunk, 0, Length);
        if (io.IO.Write(ref Chunk, Length) != Length)
        {
            throw new Exception("IO488WriteIEEEBlockExtension:
                A buffer is not transmitted correctly");
        }
    }
    else
        throw new Exception("IO488WriteIEEEBlockExtension:
            A buffer is not transmitted correctly");
}
else
    throw new Exception("IO488WriteIEEEBlockExtension:
        A device is not ready for the next command");
}
else if (io.IO.HardwareInterfaceName == "TCPIP")
{
    io.WriteString("*OPC?\n", true);
    string answer = io.ReadString().TrimEnd('\n');

    if (answer.Equals(OPERATION_COMPLETED))
        io.WriteIEEEBlock(Command, data, true);
    else
        throw new Exception("IO488WriteIEEEBlockExtension:
            A device is not ready for the next command");
}
else
    io.WriteIEEEBlock(Command, data, true);
}

private static byte[] ToByteArray(string str)
{
    System.Text.ASCIIEncoding enc = new System.Text.ASCIIEncoding();
    return enc.GetBytes(str);
}
}

```

## 4.14 Error Messages

### Error Messages

In general, whenever the 81180A receives an invalid SCPI command, it automatically generates an error. Errors are stored in a special error queue and may be retrieved from this buffer one at a time. Errors are retrieved in first-in-first-out (FIFO) order. The first error returned is the first error that was stored. When you have read all errors from the queue, the generator responds with a 0, "No error" message.

If more than 30 errors have occurred, the last error stored in the queue is replaced with -350, "Queue Overflow". No additional errors are stored until you remove errors from the queue. If no errors have occurred when you read the error queue, the generator responds with 0, "No error".

The error queue is cleared when power has been shut off or after a \*CLS command has been executed. The \*RST command does not clear the error queue. Use the following command to read the error queue:

```
SYSTem:ERRor?
```

Errors have the following format (the error string may contain up to 80 characters):

```
102,"Syntax error".
```

A complete listing of the errors that can be detected by the generator is given below.

100,"Command error". When the generator cannot detect more specific errors, this is the generic syntax error used.

101,"Invalid Character". A syntactic element contains a character, which is invalid for that type.

102,"Syntax error". Invalid syntax found in the command string.

103,"Invalid separator". An invalid separator was found in the command string. A comma may have been used instead of a colon or a semicolon. In some cases where the generator cannot detect a specific separator, it may return error -100 instead of this error.

104,"Data type error". The parser recognized a data element different than allowed.



108,"Parameter not allowed". More parameters were received than expected for the header.

109,"Missing parameter". Too few parameters were received for the command. One or more parameters that were required for the command were omitted.

128,"Numeric data not allowed". A legal numeric data element was received, but the instrument does not accept one in this position.

131,"Invalid suffix". A suffix was incorrectly specified for a numeric parameter. The suffix may have been misspelled.

148,"Character data not allowed". A character data element was encountered where prohibited by the instrument.

200,"Execution error". This is the generic syntax error for the instrument when it cannot detect more specific errors. Execution error as defined in IEEE-488.2 has occurred.

221,"Setting conflict". Two conflicting parameters were received which cannot be executed without generating an error.

222,"Data out of range". Parameter data, which followed a specific header, could not be used because its value is outside the valid range defined by the generator.

224,"Illegal parameter value". A discrete parameter was received which was not a valid choice for the command. An invalid parameter choice may have been used.

250,"Mass storage error". General error related to mass memory storage. Mass memory errors relate to the internal flash, working memory and external USB stick.

251,"Missing mass storage". This error will generate when attempting to store settings on an external USB stick but the media is not mounted.

252,"Write buffer overflow". This will occur when the writable buffer exceeds its limitation. Error relates to mass storage only.

253,"Cannot create a directory". Will be generated when the external media is incapable of creating a specific directory.

254, "Cannot delete file or directory". An attempt to delete a file or directory has failed.

255, "File extension not found". Store and recall files are expected to have certain extensions. Files that do not have the correct extension will generate this error.

256, "File name not found". An attempt to read a file name that does not exist from an external media.

257, "File type not supported". Store and recall files are expected to have certain format. Files that do not have the correct format will generate this error.

258, "Invalid specified path". An unexpected file path encountered.

300, "Device-specific-error". This is the generic device-dependent error for the instrument when it cannot detect more specific errors. A device-specific error as defined in IEEE-488.2 has occurred.

301, "Digital Pulse-specific-error". This is the generic device-dependent error for the instrument when it is attempting to construct a digital pulse but cannot detect more specific errors.

311, "Memory error". Indicates that an error was detected in the instrument's memory.

350, "Queue Overflow". The error queue is full because more than 30 errors have occurred. No additional errors are stored until the errors from the queue are removed. The error queue is cleared when power has been shut off, or after a \*CLS command has been executed.

410, "Query INTERRUPTED". A command was received which sends data to the output buffer, but the output buffer contained data from a previous command (the previous data is not overwritten). The output buffer is cleared when power is shut off or after a device clear has been executed.

---

## **SYSTEM:LOCAL**

### **Description**

This command will deactivate the active interface and will restore the 81180A to local (front panel) operation.

**SYSTem:VERSion?****Description**

Query only. This query will interrogate the 81180A for its current firmware version. The firmware version is automatically programmed to a secure location in the flash memory and cannot be modified by the user except when performing firmware update.

**Response**

The 81180A will return the current firmware version code in a format similar to the following: 1.15

**SYSTem:INFormation:CALibration?****Description**

Query only. This query will interrogate the instrument for its last calibration date.

**Response**

The generator will return the last calibration date in a format similar to the following: 24 Sep 2010 (10 characters maximum).

**SYSTem:INFormation:MODeL?****Description**

Query only. This query will interrogate the instrument for its model number in a format similar to the following: 81180A-264. The model number is programmed to a secure location in the flash memory and cannot be modified by the user.

**Response**

The generator will return its model number 81180A-116, 81180A-216, or 81180A-264.

**SYSTem:INFormation:SERial?****Description**

Query only. This query will interrogate the instrument for its serial number. The serial number is programmed to a secure location in the flash memory and cannot be modified by the user.

**Response**

The generator will return its serial number in a format similar to the following: IL50280110

**SYSTem:INFormation:HARDware?****Description**

Query only. This query will interrogate the instrument for its hardware revision level. The hardware revision includes: PCB revision, FPGA revision and FPLD revision. It is programmed to a secure location in the flash memory and cannot be modified by the user.

**Response**

The generator will return its hardware revisions in a format similar to the following: E, D, A

## **SYSTem:POWerup{DEFault|SETup}{?}**

### **Description**

Use this command to define how the 81180A powers up. Normally, the instrument powers up with its parameters rest to factory default setting however, if one requires that the instrument powers up with its last setting, this could be changed using this command. Using the "SET" option is not recommended in conjunction with long waveform segments because the instrument powers down and then up only after the waveforms have been stored in its internal flash memory; an operation that may last very long.

### **Parameters**

<b>Name</b>	<b>Type</b>	<b>Default</b>	<b>Description</b>
DEFault	Discrete	DEF	Selects the factory reset as the power up setting of the instrument.
SETup	Discrete		Selects the last setup before power down as the power up setting for the instrument.

### **Response**

The 81180A will return DEF or SET, depending on the present power up setting.

## **4.15 IEEE-STD-488.2 Common Commands and Queries**

### **IEEE-STD-488.2**

#### **Common Commands and Queries**

Since most instruments and devices in an ATE system use similar commands that perform similar functions, the IEEE-STD-488.2 document has specified a common set of commands and queries that all compatible devices must use. This avoids situations where devices from various manufacturers use different sets of commands to enable functions and report status.

The IEEE-STD-488.2 treats common commands and queries as device dependent commands. For example, \*TRG is sent over the bus to trigger the instrument. Some common commands and queries are optional, but most of them are mandatory.

The following is a complete listing of all common-commands and queries, which are used by the 81180A

**\*RST** - Resets the generator to its default state.

**\*TRG** - Triggers the generator from the remote interface. This command effects the generator if it is first placed in the Trigger or Burst mode of operation and the trigger source is set to "BUS". **\*CLS** - Clear the Status Byte summary register and all event registers.

**\*OPC?** - Returns "1" to the output buffer after all the previous commands have been executed. \*OPC? is used for synchronization between a controller and the instrument using the MAV bit in the Status Byte or a read of the Output Queue. Reading the response to the **\*OPC?** query has the advantage of removing the complication of dealing with service requests and multiple polls to the instrument. However, both the system bus and the controller handshake are in a temporary hold-off state while the controller is waiting to read the \*OPC? query response.

**\*STB?** - Query the Status Byte summary register. The \*STB? command is similar to a serial poll but is processed like any other instrument command. The \*STB? command returns the same result as a serial poll, but the "request service" bit (bit 6) is not cleared if a serial poll has occurred.

**\*IDN?** - Query the generator's identity. The returned data is organized into four fields, separated by commas. The generator responds with its manufacturer and model number in the first two fields, and may also report its serial number and options in fields three and four. If the latter information is not available, the device must return an ASCII 0 for each.

**\*OPT?** - Returns the instrument option: 116 for 1 ch, 16M; 216 for 2 ch, 16M; 264 for 2 ch, 64M.

---



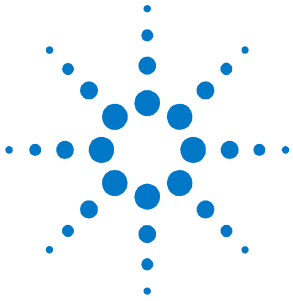

## 5 Performance Verification

### 5.1 What's in This Chapter

#### What's in This Chapter

This chapter provides performance tests necessary to troubleshoot the Model 81180A Universal Waveform Generator.



#### WARNING

The procedures described in this section are for use only by qualified service personnel. Do not remove instrument covers as it may affect product characteristics and temperature.

---



#### CAUTION

ALWAYS PERFORM PERFORMANCE TESTS IN A STATIC SAFE WORKSTATION.

---

### 5.2 Performance Checks

**Performance Checks** The following performance checks verify proper operation of the instrument and should normally be used:

As a part of the incoming inspection of the instrument specifications;

As part of the troubleshooting procedure;

After any repair or adjustment before returning the instrument to regular service.

---

## 5.3 Environmental Conditions

**Environmental Conditions** Tests should be performed under laboratory conditions having an ambient temperature of 25°C,  $\pm 5^\circ\text{C}$  and at relative humidity of less than 80%. If the instrument has been subjected to conditions outside these ranges, allow at least one additional hour for the instrument to stabilize before beginning the adjustment procedure.

---

## 5.4 Warm-up Period

**Warm-up Period** Most equipment is subject to a small amount of drift when it is first turned on. To ensure accuracy, turn on the power to the Model 81180A and allow it to warm-up for at least 30 minutes before beginning the performance test procedure.

---

## 5.5 Initial Instrument Setting

**Initial Instrument Setting** To avoid confusion as to which initial setting is to be used for each test, it is required that the instrument be reset to factory default values prior to each test. To reset the Model 81180A to factory defaults, use the Factory Rest option in the Utility menu.

---

## 5.6 Recommended Test Equipment

**Recommended Test Equipment** Recommended test equipment for troubleshooting, calibration and performance checking is listed in *Table 5-1* below. Test instruments other than those listed may be used only if their specifications equal or exceed the required characteristics.

---



Table 5-1: Recommended Test Equipment

Equipment	Model No.	Manufacturer
Oscilloscope	DSA90604A	Agilent
Digital Multimeter	3458A	Agilent
Frequency Counter	53132A	Agilent
Spectrum Analyzer	N9010A	Agilent
Function Generator	33250A	Agilent
Signal Generator	N5181A	Agilent
Power Meter	N1913A	Agilent
Power Sensor	E9304A	Agilent

## 5.7 Test Procedures

### Test Procedures

Use the following procedures to check the Model 81180A against the specifications. The following paragraphs show how to set up the instrument for the test, what the specifications for the tested function are, and what acceptable limits for the test are. If the instrument fails to perform within the specified limits, the instrument must be calibrated or tested to find the source of the problem.



#### NOTE

The accuracy of the instrument depends largely on proper termination of the output cable.

There are two types of termination resistors that should be used:

1. 50Ω feedthrough (normally used at the load end), and
2. SMA 50Ω termination cap (normally plugged directly on the output terminal).

Unless otherwise noted, terminate the outputs as follows throughout the test procedures:

1. Differential DC-coupled: Both cable ends must be terminated at the load side.
2. Single-ended DC-coupled: Terminate the output cable end at the load side; terminate the unused output at the output connector.
3. Differential DAC-coupled: Both cable ends must be terminated at the load side.
4. Single-ended DAC-coupled: Terminate the output cable end at the load side; terminate the unused output at the output connector.
5. Single-ended AC-coupled: Terminate the output cable end at the load side.

## 5.8 Frequency Accuracy

**Frequency Accuracy** Frequency accuracy checks tests the accuracy of the generator using internal and external oscillator references. Both channels share the same reference oscillators and therefore, the accuracy is tested on channel 1 only.

---

### 5.8.1 Frequency Accuracy, Internal Reference

**Frequency Accuracy,** Equipment: Counter

**Internal Reference** Preparation:

1. Configure the counter as follows:  
Termination: 50 $\Omega$ , DC coupled
2. Connect the 81180A Channel 1 output to the counter input – channel 1
3. Configure the 81180A, channel 1 as follows:  
Waveform: Square wave  
Amplitude: 2V  
Output: On  
Frequency: As specified in *Table 5-2*

Test Procedure:

1. Perform frequency Accuracy tests using *Table 5-2*.
- 

**Table 5-2: Frequency Accuracy**

81180A Setting	Error Limits	Counter Reading	Pass	Fail
10 kHz	$\pm 10$ mHz			
100 kHz	$\pm 100$ mHz			
10 MHz	$\pm 10$ Hz			
100 MHz	$\pm 100$ Hz			
250 MHz	$\pm 250$ Hz			

## 5.8.2 Frequency Accuracy, External 100 MHz Reference

**Frequency Accuracy, External 100 MHz Reference** Equipment: 100 MHz reference (at least 0.1ppm), Counter  
Preparation:

1. Leave counter setting and 81180A connections as in last test
2. Connect the 100 MHz reference oscillator to the 81180A rear panel reference input
3. Configure the 81180A channel 1 as follows:  
Ref Clock Source: External  
Waveform: Square wave  
Output: On  
Frequency: As specified in *Table 5-3*

Test Procedure

1. Perform frequency Accuracy tests using *Table 5-3*



### NOTE

The external reference input accepts frequencies from 10 MHz to 100 MHz. This validation procedure recommends 100 MHz reference however, other reference frequencies may be used for this test but the external frequency value must be adjusted accordingly in the Clocks menu.

**Table 5-3: Frequency Accuracy Using External 100 MHz Reference**

81180A Setting	Error Limits	Counter Reading	Pass	Fail
10 MHz	±1 Hz			
100 MHz	±10 Hz			

## 5.8.3 Frequency Accuracy, External Sample Clock

**Frequency Accuracy, External Sample Clock** Equipment: Signal Generator (at least 0.1ppm), Counter  
Preparation:

1. Configure the counter as follows:  
Function: Frequency  
Gate Time: 1 ms
2. Connect the signal generator output to the rear-panel External SCLK input.
3. Configure the signal generator as follows:  
Amplitude: 0 dBm

Frequency: As required by the test

4. Configure the 81180A channel 1 as follows:

Function: Arbitrary

Waveform: Square wave, 1024 points, 256 cycles

CH1 SCLK: EXT

Ext SCLK Freq: As required by the test

Divider: As required by the test

CH1 Output: On

Test Procedure

1. Perform frequency Accuracy, external sample clock tests using *Table 5-4*.



**NOTE**

The external sample clock input accepts frequencies from 1.8 GHz to 4.2 GHz. Every time you change the external reference frequency, the EXT SCLK FREQ field in the Clocks menu must be set accordingly. Failure to set up the SCLK reference may result in output inaccuracies.

**Table 5-4: Frequency Accuracy Using External Sample Clock**

Signal Generator Setting	81180A Divider Setting	Counter Reading Limits	Counter Reading	Pass	Fail
1.8 GHz	1	450 MHz, $\pm 45$ Hz			
2.4 GHz	1	600 MHz, $\pm 60$ Hz			
4.2 GHz	1	1,050 MHz, $\pm 105$ Hz			
1.8 GHz	2	225 MHz, $\pm 22.5$ Hz			
3.2 GHz	16	50 MHz, $\pm 5$ Hz			
4.2 GHz	64	16.40625 MHz, $\pm 1.64$ Hz			
4.2 GHz	128	8.203125 MHz, $\pm 0.82$ Hz			
4.2 GHz	256	4.1015625 MHz, $\pm 0.41$ Hz			

### 5.8.4 Phase Noise Test

**Phase Noise Test**

Equipment: Spectrum Analyzer

Preparation:

1. Connect 81180A outputs to the spectrum analyzer input.
2. Configure the 81180A as follows:

Function: Arbitrary

Outputs: On

Sample Clock: 4.2 GSa/s

Waveform: Sine (1024 points, 32 cycles)

Test Procedure

1. Perform Phase Noise Accuracy tests using Table 5-5.

**Table 5-5: Phase Noise Test**

81180A Freq Settings	Reading Limits	Spectrum Analyzer Setting	Results		Pass	Fail
			CH 1	CH 2		
131.25 MHz	>89 dBc/Hz	Phase Noise				

### 5.8.5 Amplitude Accuracy

**Amplitude Accuracy** Amplitude accuracy checks tests the accuracy of the output amplifier and attenuators. Each channel has its own set of amplifiers and attenuators and therefore, the accuracy is tested on each channel separately. Amplitude accuracy is checked for the direct DAC path as well as for the DC and AC paths.

### 5.8.6 Amplitude Accuracy, Direct DAC Output

**Amplitude Accuracy,** Equipment: DMM

**Direct DAC Output** Preparation:

1. Configure the DMM as follows:  
Function: ACV  
Range: As required by the test
2. Connect 81180A Channel outputs to the DMM input
3. Configure the 81180A as follows:  
Frequency: 10 kHz  
Outputs: On  
Couple: DAC  
Amplitude: As specified in *Table 5-6*

Test Procedure

1. Perform amplitude Accuracy tests on both channels using *Table 5-6*.

**Table 5-6: Amplitude Accuracy, Direct DAC output**

81180A Amplitude Setting	Error Limits	DMM Reading		Pass	Fail
		CH 1	CH 2		
500 mV	176.77 mV, $\pm 10.3$ mV				
100 mV	35.35 mV, $\pm 6$ mV				

### 5.8.7 Amplitude Accuracy, DC Output

**Amplitude Accuracy, DC Output** Equipment: DMM  
Preparation:

1. Configure the DMM as follows:  
Function: ACV  
Range: As required by the test
2. Connect 81180A Channel outputs to the DMM input
3. Configure the 81180A as follows:  
Frequency: 10 kHz  
Outputs: On  
Amplitude: As specified in *Table 5-7*

Test Procedure

1. Perform amplitude Accuracy tests on both channels using *Table 5-7*.

**Table 5-7: Amplitude Accuracy, DC output**

81180A Amplitude Setting	Error Limits	DMM Reading		Pass	Fail
		CH 1	CH 2		
2 V	707.1 mV, $\pm 26.2$ mV				
1 V	353.55 mV, $\pm 15.6$ mV				
500 mV	176.77 mV, $\pm 10.3$ mV				
100 mV	35.35 mV, $\pm 6$ mV				

### 5.8.8 Power Accuracy, AC Coupled Output

**Power Accuracy, AC Coupled Output** Equipment: Power meter  
Preparation:

1. Connect 81180A Channel outputs to the power meter input
2. Configure the 81180A as follows:  
Outputs: On

Couple: AC

Power: As specified in *Table 5-8*

Test Procedure

1. Perform power Accuracy tests on both channels using *Table 5-8*.

**Table 5-8: Power Accuracy, AC Coupled Output**

81180A Power Setting	Error Limits	Power Meter Reading		Pass	Fail
		CH 1	CH 2		
-5 dBm	-5 dBm, $\pm 0.65$ dBm				
0 dBm	0 dBm, $\pm 0.5$ dBm				
5 dBm	5 dBm, $\pm 0.65$ dBm				

## 5.9 Offset Accuracy

### Offset Accuracy

Offset accuracy checks tests the accuracy of the offset generators. Each channel has its own set of offset generators and therefore, the accuracy is tested on each channel separately. Offset accuracy is checked for the direct DAC path as well as for the DC and AC paths.

### 5.9.1 Offset Accuracy, Direct DAC Output

#### Offset Accuracy, Direct DAC Output

Equipment: DMM

Preparation:

1. Configure the DMM as follows:  
Function: DCV  
Range: As required by the test
2. Connect the 81180A outputs to the DMM input
3. Configure the 81180A as follows:  
Frequency: 1 MHz  
Amplitude: 50 mV  
Outputs: On  
Couple: DAC  
Offset: As specified in *Table 5-9*

Test Procedure

1. Perform Offset Accuracy tests on both channels using *Table 5-9*.

**Table 5-9: Offset Accuracy, Direct DAC Output**

81180A Offset Setting	Error Limits	DMM Reading		Pass	Fail
		CH 1	CH 2		
+1.5 V	1.5 V, $\pm 80$ mV				
+750 mV	750 mV, $\pm 42.5$ mV				
0 V	0 V, $\pm 5$ mV				
-750 mV	-750 mV, $\pm 42.5$ mV				
-1.5 V	-1.5 V, $\pm 80$ mV				

## 5.9.2 Offset Accuracy, DC Output

**Offset Accuracy, DC Output** Equipment: DMM  
Preparation:

1. Configure the DMM as follows:  
Function: DCV  
Range: As required by the test
2. Connect 81180A Channel 1/2 output to the DMM input
3. Configure the 81180A as follows:  
Frequency: 1 MHz  
Amplitude: 50 mV  
Outputs: On  
Offset: As specified in *Table 5-10*

Test Procedure

1. Perform Offset Accuracy tests on both channels using *Table 5-10*.

**Table 5-10: Offset Accuracy, DC Output**

81180A Offset Setting	Error Limits	DMM Reading		Pass	Fail
		CH 1	CH 2		
+1.5 V	1.5 V, $\pm 80$ mV				
+750 mV	750 mV, $\pm 42.5$ mV				
0 V	0 V, $\pm 5$ mV				
-750 mV	-750 mV, $\pm 42.5$ mV				
-1.5 V	-1.5 V, $\pm 80$ mV				



## 5.10 Square Wave Characteristics

### Square Wave Characteristics

This tests the characteristics of the square waveform. It includes transition times, aberrations and skew between channels. Each channel has its own set of amplifiers and attenuators and therefore, the characteristics are tested on each channel separately. The square wave characteristics are tested separately for the direct DAC and the DC outputs.

---

### 5.10.1 Square Wave Checks, Direct DAC Output

**Square Wave Checks**, Equipment: Oscilloscope

**Direct DAC Output** Preparation:

1. Configure the Oscilloscope follows:  
Setup: As required for the test
2. Connect 81180A outputs to the oscilloscope input
3. Configure the 81180A as follows:

Frequency: 1 MHz

Waveform: Square wave

Couple Mode: DAC

Amplitude: 500 mV

Outputs: On

Test Procedure

1. Perform Square Wave Characteristics tests on both channels using *Table 5-11*.
- 

**Table 5-11: Square Wave Characteristics, Direct DAC Output**

Parameter Tested	Error Limits	Oscilloscope Reading		Pass	Fail
		CH 1	CH 2		
Rise/Fall Time	<380 ps				
Ringing	<18% + 15mV				
Over/undershoot	<18% + 15mV				

### 5.10.2 Square Wave Checks, DC Output

**Square Wave Checks**, Equipment: Oscilloscope

**DC Output** Preparation:

1. Configure the Oscilloscope follows:

Setup: As required for the test

2. Connect 81180A outputs to the oscilloscope input

3. Configure the 81180A as follows:

Frequency: 1 MHz

Waveform: Square wave

Couple Mode: DC

Amplitude: 1 V

Outputs: On

Test Procedure

1. Perform Square Wave Characteristics tests on both channels using *Table 5-12*.

---

**Table 5-12: Square Wave Characteristics, Direct DAC Output**

Parameter Tested	Error Limits	Oscilloscope Reading		Pass	Fail
		CH 1	CH 2		
Rise/Fall Time	<660 ps				
Ringing	<6% + 15mV				
Over/undershoot	<6% + 15mV				

## 5.11 Sinewave Characteristics

### Sinewave Characteristics

This tests the characteristics of the sine waveform. It includes distortions, spectral purity, spurs and flatness. Each channel has its own set of amplifiers and attenuators and therefore, the characteristics are tested on each channel separately. Tests are done on all output coupling paths: DAC, DC and AC.

---

### 5.11.1 Sinewave Spectral Purity, DAC Output

#### Sinewave Spectral Purity, DAC Output

Equipment: Spectrum Analyzer, Balun Adapter

Preparation:

1. Connect 81180A outputs to the spectrum analyzer input.

2. Configure the 81180A as follows:

Amplitude: 500 mV

Function: Arbitrary

Couple: DAC

Outputs: On

Sample Clock: 4.2 GSa/s

Waveform: Sine

Frequency: 131.25 MHz (1,024 points, 32 cycles)

200 MHz (6,720 points, 320 cycles)

500 MHz (2688 points, 320 cycles)

800 MHz 16,800 points, 3200 cycles)

Test Procedure

1. Perform sinewave spectral purity, DAC waveforms tests using *Table 5-13* through *Table 5-16*. Note for testing sinewave harmonics, connect the Normal and inverted outputs through a balun circuit (double input to single output).
2. For testing *Table 5-15* and *Table 5-16*, remove the balun circuit and place VLFX-650 filter on the Normal output.

Table 5-13: Sinewave Harmonics Test, DAC Output

81180A Freq Settings	Reading Limits	Spectrum Analyzer, Settings & Results				Pass	Fail
		Start	Stop	CH 1	CH 2		
131.25 MHz	-55 dBc	10 MHz	1 GHz				

Table 5-14: Sinewave Spurious Test, DAC Output

81180A Freq Settings	Reading Limits	Spectrum Analyzer, Settings & Results				Pass	Fail
		Start	Stop	CH 1	CH 2		
131.25 MHz	-63 dBc	10 MHz	1 GHz				

Table 5-15: Sinewave SCLK/2 Spur Test, DAC Output

81180A Freq Settings	Reading Limits	Spectrum Analyzer, Settings & Results				Pass	Fail
		Start	Stop	CH 1	CH 2		
200 MHz	-62 dBc	100 MHz	2.5 GHz				
500 MHz	-62 dBc	100 MHz	2.5 GHz				
800 MHz	-62 dBc	100 MHz	2.5 GHz				

Table 5-16: Sinewave SCLK/2-Fout Spurs Test, DAC Output

81180A Freq Settings	Reading Limits	Spectrum Analyzer, Settings & Results				Pass	Fail
		Start	Stop	CH 1	CH 2		
200 MHz	-66 dBc	100 MHz	2.5 GHz				
500 MHz	-66 dBc	100 MHz	2.5 GHz				
800 MHz	-50 dBc	100 MHz	2.5 GHz				

### 5.11.2 Sinewave Spectral Purity, DC Output

**Sinewave Spectral Purity, DC Output** Equipment: Spectrum Analyzer  
Preparation:

1. Connect 81180A outputs to the spectrum analyzer input.

2. Configure the 81180A as follows:

Amplitude: 1 V

Function: Arbitrary

Couple: DC

Outputs: On

Sample Clock: 4.2 GSa/s

Waveform: Sine

Frequency: 131.25 MHz (1,024 points, 32 cycles)

200 MHz (6,720 points, 320 cycles)

500 MHz (2,688 points, 320 cycles)

800 MHz 16,800 points, 3,200 cycles)

#### Test Procedure

1. Perform sinewave spectral purity, DAC waveforms tests using *Table 5-17* through *Table 5-20*. Note for testing sinewave harmonics, connect the Normal and inverted outputs through a balun circuit (double input to single output).

Table 5-17: Sinewave Harmonics Test, DC Output

81180A Freq Settings	Reading Limits	Spectrum Analyzer, Settings & Results				Pass	Fail
		Start	Stop	CH 1	CH 2		
131.25 MHz	-48 dBc	10 MHz	1 GHz				

Table 5-18: Sinewave Spurious Test, DC Output

81180A Freq Settings	Reading Limits	Spectrum Analyzer, Settings & Results				Pass	Fail
		Start	Stop	CH 1	CH 2		
131.25 MHz	-67 dBc	10 MHz	600 MHz				

Table 5-19: Sinewave SCLK/2 Spur Test, DC Output

81180A Freq Settings	Reading Limits	Spectrum Analyzer, Settings & Results				Pass	Fail
		Start	Stop	CH 1	CH 2		
200 MHz	-41 dBc	100 MHz	2.5 GHz				
500 MHz	-39 dBc	100 MHz	2.5 GHz				
800 MHz	-34 dBc	100 MHz	2.5 GHz				

Table 5-20: Sinewave SCLK/2-Fout Spurs Test, DC Output

81180A Freq Settings	Reading Limits	Spectrum Analyzer, Settings & Results				Pass	Fail
		Start	Stop	CH 1	CH 2		
200 MHz	-44 dBc	100 MHz	2.5 GHz				
500 MHz	-41 dBc	100 MHz	2.5 GHz				
800 MHz	-34 dBc	100 MHz	2.5 GHz				

### 5.11.3 Sinewave Spectral Purity, AC Output

**Sinewave Spectral Purity, AC Output**    Equipment: Spectrum Analyzer  
Preparation:

1. Connect 81180A Channel 1/2 output to the spectrum analyzer input.
2. Configure the 81180A as follows:

Amplitude: 500 mV

Function: Arbitrary

Sample Clock: 4.2 GSa/s

Waveform: Sine

Outputs: On

Frequency: 131.25 MHz (1,024 points, 32 cycles)

200 MHz (6,720 points, 320 cycles)

500 MHz (2,688 points, 320 cycles)

800 MHz 16,800 points, 3,200 cycles)

Test Procedure

1. Perform sinewave spectral purity, AC Output tests using *Table 5-21* through *Table 5-24*. For testing *Table 5-23* and *Table 5-24*, place VLFX-650 filter on the Normal output.

**Table 5-21: Sinewave Harmonics Test, AC Output**

81180A Freq Settings	Reading Limits	Spectrum Analyzer, Settings & Results				Pass	Fail
		Start	Stop	CH 1	CH 2		
131.25 MHz	-49 dBc	10 MHz	1 GHz				

**Table 5-22: Sinewave Spurious Test, AC Output**

81180A Freq Settings	Reading Limits	Spectrum Analyzer, Settings & Results				Pass	Fail
		Start	Stop	CH 1	CH 2		
131.25 MHz	-57 dBc	10 MHz	1.5 GHz				

**Table 5-23: Sinewave SCLK/2 Spur Test, AC Output**

81180A Freq Settings	Reading Limits	Spectrum Analyzer, Settings & Results				Pass	Fail
		Start	Stop	CH 1	CH 2		
200 MHz	-67 dBc	100 MHz	2.5 GHz				
500 MHz	-67 dBc	100 MHz	2.5 GHz				
800 MHz	-67 dBc	100 MHz	2.5 GHz				

**Table 5-24: Sinewave SCLK/2-Fout Spurs Test, AC Output**

81180A Freq Settings	Reading Limits	Spectrum Analyzer, Settings & Results				Pass	Fail
		Start	Stop	CH 1	CH 2		
200 MHz	-67 dBc	100 MHz	2.5 GHz				
500 MHz	-67 dBc	100 MHz	2.5 GHz				
800 MHz	-54 dBc	100 MHz	2.5 GHz				

### 5.11.4 Sinewave Flatness, AC Output

**Sinewave Flatness, AC Output**      Equipment: Power Meter  
Preparation:

1. Connect 81180A outputs to the power meter input.
2. Configure the 81180A as follows:
  - Power: 5 dBm
  - Output: On
  - Function: Arbitrary
  - Sample Clock: 4.2 GSa/s
  - Waveform: Sine
  - Frequency: 100 MHz (134,400 points, 3,200 cycles)
  - 500 MHz (26,880 points, 3,200 cycles)
  - 750 MHz (17,920 points, 3,200 cycles)
  - 1 GHz (13,440 points, 3,200 cycles)
  - 1.25 GHz (10,752 points, 3,200 cycles)
  - 1.5 GHz (8,960 points, 3,200 cycles)

#### Test Procedure

1. Note the power reading at 100 MHz and mark the value as reference.
2. Perform sinewave flatness, AC waveforms tests using *Table 5-25*.

**Table 5-25: Sinewave Flatness Test, AC Output**

81180A Freq Settings	Reading Limits	Power Meter Reading		Pass	Fail
		CH 1	CH 2		
100 MHz	Reference, <0.5 dBm				
500 MHz	5 dBm, $\pm 1.1$ dBm				
750 MHz	5 dBm, $\pm 1.1$ dBm				
1 GHz	5 dBm, $\pm 1.1$ dBm				
1.25 GHz	5 dBm, $\pm 2.1$ dBm				
1.5 GHz	5 dBm, $\pm 2.1$ dBm				

## 5.12 Inter-Channel Propagation Characteristics

### Inter-Channel Propagation Characteristics

This tests the offset and skew characteristics between the two channels. This does not change when using one or another output path and therefore, the tests are performed on the DC output path only.

---

### 5.12.1 Offset Between Channels

#### Offset Between Channels

Equipment: Oscilloscope

Preparation:

1. Configure the Oscilloscope follows:  
Setup: As required for the test
2. Connect 81180A outputs to the oscilloscope inputs
3. Configure the 81180A as follows:

Function: Arbitrary

Waveform: Square, 1024 points, single cycle

SCLK: 4 GSa/s

SCLK Feed: Common

Amplitude: 1 V

Outputs: On

Offset: 0 points

Test Procedure

1. Measure the initial Offset between the channels to be less than  $\pm 200$  ps
- 

Test Results	Pass		Fail	
--------------	------	--	------	--

2. Change CH2 -> offset to 64 points and verify offset reading on the oscilloscope is 16 ns  $\pm 200$  ps
  3. Restore CH2 -> Offset to 0 points
  4. Change CH2 <- offset to 64 points and verify offset reading on the oscilloscope is 16 ns  $\pm 200$  ps
- 

Test Results	Pass		Fail	
--------------	------	--	------	--



### 5.12.2 Skew Between Channels

**Skew Between Channels**

Equipment: Oscilloscope

Preparation:

1. Configure the Oscilloscope follows:  
Setup: As required for the test
2. Connect 81180A outputs to the oscilloscope inputs
3. Configure the 81180A as follows:

Function: Arbitrary

Waveform: Square, 1024 points, single cycle

SCLK: 4.2 GSa/s

SCLK Feed: Common

Amplitude: 1 V

Outputs: On

Skew: 0 ns

Test Procedure

1. Measure the skew between the channels. Should be less than 200 ps. Record this value as reference for the next steps (T0).

Test Results	Pass		Fail	
--------------	------	--	------	--

2. Change CH2 -> Skew to 1 ns and verify skew reading on the oscilloscope is  $1\text{ ns} + T0 \pm 120\text{ ps}$ .
3. Restore CH2 -> to 0 ns.
4. Change CH2 <- Skew to 1 ns and verify skew reading on the oscilloscope is  $1\text{ ns} + T0 \pm 200\text{ ps}$ .

Test Results	Pass		Fail	
--------------	------	--	------	--

## 5.13 Run Mode Tests

### Run Mode Tests

This tests the operation of the various run modes. There are three run modes: Continuous, Triggered and Gated. These tests do not challenge the individual inputs but only tests the operation of the standard functions in all three modes. Additional tests will be carried out on individual trigger inputs and on other instrument functions.

---

### 5.13.1 Continuous Run Mode Test

**Continuous Run Mode** Equipment: Oscilloscope, Function Generator

#### Test

Preparation:

1. Configure the oscilloscope follows:

Setup: As required for the test

2. Configure the function generator as follows:

Frequency: 1 MHz

Amplitude: 2 V

Offset: 1 V

Run Mode: Triggered

3. Connect 81180A outputs to the oscilloscope inputs

4. Configure the 81180A as follows:

Outputs: On

Run Mode: Continuous

Enable Mode: Armed

Enable Source: TRIG

Test Procedure

1. Observe that there is no signals are generated at the 81180A outputs.
  2. Press MAN and observe that the 81180A now generates 10 MHz sine waveforms.
  3. Press the Abort soft key and observe that the signal is no longer generated.
- 

Test Results	Pass		Fail	
--------------	------	--	------	--

4. Connect the function generator to the front panel trigger input.
5. Press the manual trigger button on the function generator and observe

that the 81180A generates 10 MHz sine waveforms.

6. Press the Abort soft key and observe that the signal is no longer generated.

---

Test Results	Pass		Fail	
--------------	------	--	------	--

7. Modify the 81180A Enable Source to setting BUS and remove the function generator cable from the event input.
8. Generate \*trg from remote and observe that the 81180A generates 10 MHz sine waveforms.
9. Use a remote ABORt signal and observe that the signal is no longer generated.

---

Test Results	Pass		Fail	
--------------	------	--	------	--

### 5.13.2 Triggered Run Mode Test

**Triggered Run Mode Test** Equipment: Oscilloscope, Function Generator, Counter  
Preparation:

1. Configure the oscilloscope follows:  
Setup: As required for the test
2. Configure the function generator as follows:  
Frequency: 1 MHz  
Amplitude: 2 V  
Offset: 1 V
3. Connect 81180A outputs to the oscilloscope inputs
4. Configure the 81180A as follows:  
Outputs: On  
Run Mode: Triggered  
Trigger Source: EXT

#### Test Procedure

1. Observe that there is no signals are generated at the 81180A outputs.
  2. Press MAN and observe that the 81180A generates a single 10 MHz sine waveform every time you press the button.
  3. Connect the 81180A channel 1 output to the counter input-channel 1.
-

Test Results	Pass		Fail	
--------------	------	--	------	--

4. Connect the function generator to the front panel trigger input.
  5. Observe that the counter reading is 1 MHz (Accuracy is equal to the accuracy of the function generator output).
- 

Test Results	Pass		Fail	
--------------	------	--	------	--

6. Modify the 81180A Trigger Source to setting Event.
  7. Connect the function generator to the rear panel event input.
  8. Observe that the counter reading is 1 MHz (Accuracy is equal to the accuracy of the function generator output).
- 

Test Results	Pass		Fail	
--------------	------	--	------	--

9. Modify the 81180A Trigger Source to setting BUS and remove the function generator cable from the event input.
  10. Program the counter to Totalize measurements.
  11. Generate 10 events of \*trg from remote and observe that the counter reading is 10.
- 

Test Results	Pass		Fail	
--------------	------	--	------	--

### 5.13.3 Gated Run Mode Test

**Gated Run Mode Test** Equipment: Oscilloscope, Function Generator

Preparation:

1. Configure the oscilloscope follows:  
Setup: As required for the test
2. Configure the function generator as follows:  
Frequency: 100 kHz  
Amplitude: 2 V  
Offset: 1 V
3. Connect 81180A outputs to the oscilloscope inputs
4. Configure the 81180A as follows:

Outputs: On  
Run Mode: Gated

#### Test Procedure

1. Observe that there is no signals are generated at the 81180A outputs.
2. Press MAN and observe that the 81180A generates 10 MHz sine waveforms as long as you keep the MAN button depressed.

---

Test Results	Pass		Fail	
--------------	------	--	------	--

3. Connect the function generator to the front panel trigger input.
4. Observe that the 81180A generates bursts of 10 MHz sine waveforms for roughly 5  $\mu$ s and then DC.

---

Test Results	Pass		Fail	
--------------	------	--	------	--

## 5.14 Trigger Inputs Tests

**Trigger Inputs Tests** This tests the operation of the individual trigger inputs. The 81180A can accept trigger signals from a number of sources: Front panel trigger input, Rear panel event input, Internal trigger generator and remote trigger commands from a host computer. The characteristics of these inputs are checked using the following tests.

### 5.14.1 Front Panel Trigger Input Test

**Front Panel Trigger Input Test** Equipment: Function Generator, Counter/Timer  
Preparation:

1. Configure the counter to Period measurements.
2. Configure the function generator as follows:  
Frequency: 1 MHz  
Amplitude: 0.2 V  
Offset: -1 V  
Waveform: Square
3. Connect the function generator output to the 81180A trigger input.
4. Connect the 81180A outputs to the counter input – channel 1.
5. Configure the 81180A as follows:

Outputs: On

Run Mode: Triggered

Trigger Level: As specified by the test

Trigger Slope: As specified by the test

Test Procedure

1. Check the trigger level and slope operation using *Table 5-26*. Note that accuracy of the measurement is directly related to the accuracy of the function generator.
- 

**Table 5-26: Trigger Input Characteristics**

81180A Trigger Level	81180 Trigger Slope	Counter Reading		Pass	Fail
		CH 1	CH 2		
-2 V	Positive	1 $\mu$ s	1 $\mu$ s		
-2 V	Negative	1 $\mu$ s	1 $\mu$ s		
-2 V	Either	500 ns	500 ns		

2. Modify the function generator offset setting to 1 V.
  3. Continue with the trigger level and trigger slope tests using *Table 5-27*.
- 

**Table 5-27: Trigger Input Characteristics Checks, Continued**

81180A Trigger Level	81180 Trigger Slope	Counter Reading		Pass	Fail
		CH 1	CH 2		
2 V	Positive	1 $\mu$ s	1 $\mu$ s		
2 V	Negative	1 $\mu$ s	1 $\mu$ s		
2 V	Either	500 ns	500 ns		

4. Modify the function generator frequency setting to 1Hz.
  5. Configure the counter to Totalize measurements.
  6. Modify the Count field as shown in *Table 5-28* and continue with the counted burst tests using *Table 5-28*.
-

Table 5-28: Trigger Input Counted Burst Checks

81180A Trigger Count	Counter/Timer Reading		Pass	Fail
	CH 1	CH 2		
2	Counts multiples of 2	Counts multiples of 2		
10,000	Counts multiples of 10,000	Counts multiples of 10,000		
1,000,000	Counts multiples of 1,000,000	Counts multiples of 1,000,000		

### 5.14.2 Rear Panel Event Input Test

#### Rear Panel Event Input Test

Equipment: Counter, Function Generator

Preparation:

1. Configure the counter to Period measurements.
2. Configure the function generator as follows:

Frequency: 1 MHz

Amplitude: 0.2 V

Offset: -1 V

Waveform: Square

3. Connect the function generator output to the 81180A event input.
4. Connect 81180A outputs to the counter input – channel 1.
5. Configure the 81180A as follows:

Outputs: On

Run Mode: Triggered

Trigger Source: Event Input

Event Level: As specified by the test

Event Slope: As specified by the test

Test Procedure

1. Check the event level and slope operation using *Table 5-29*.

Table 5-29: Event Input Characteristics

81180A Event Level	81180 Event Slope	Counter Reading		Pass	Fail
		CH 1	CH 2		
-2 V	Positive	1 $\mu$ s	1 $\mu$ s		
-2 V	Negative	1 $\mu$ s	1 $\mu$ s		
-2 V	Either	500 ns	500 ns		

2. Modify the function generator offset setting to 1 V.
3. Continue with the event level and event slope tests using *Table 5-30*.

Table 5-30: Event Input Characteristics Checks, Continued

81180A Event Level	81180 Event Slope	Counter Reading		Pass	Fail
		CH 1	CH 2		
2 V	Positive	1 $\mu$ s	1 $\mu$ s		
2 V	Negative	1 $\mu$ s	1 $\mu$ s		
2 V	Either	500 ns	500 ns		

### 5.14.3 Delayed Trigger Characteristics

**Delayed Trigger Characteristics**

Equipment: Function generator, Oscilloscope

Preparation:

1. Configure the Function generator as follows:  
 Frequency: 1 MHz  
 Amplitude: 2 V  
 Offset: 1 V  
 Waveform: Square
2. Place a "T" BNC connector on the front panel trigger input connector. Connect one side of the "T" to the output connector of the function generator and the other side of the "T" to the oscilloscope input – channel 1
3. Connect the 81180A outputs to channel 2 input of the oscilloscope.
4. Configure the counter to TI A to B measurements
5. Configure the 81180A as follows:  
 Function: Arbitrary  
 SCLK: 4.2 GSa/s  
 Waveform: Square, 1024 points, 1 cycle  
 Run Mode: Triggered  
 Delay: As required for the test  
 CH1 Output: On  
 SYNC: On

Test Procedure

1. Note and record the system delay with the 81180A delay set to 0 points. Always add the system delay value to the actual result.
2. Perform trigger delay tests using *Table 5-31*. The delay is measured in reference to the SYNC output pulse.



Table 5-31: Trigger Delay Tests

81180A Delay Setting	Error Limits	Oscilloscope Reading		Pass	Fail
		CH1	CH2		
0	Reference, <97 ns				
1,024	Ref +243.8 ns, $\pm 2$ ns				
102,400	Ref +24380 ns, $\pm 2$ ns				
1,024,000	Ref +243809 ns, $\pm 2$ ns				

#### 5.14.4 Timed Internal Trigger Tests

**Timed Internal Trigger** Equipment: Counter

##### Tests

Preparation:

1. Connect the 81180A outputs to channel A input of the counter.
2. Configure the counter to Period measurements
3. Configure the 81180A as follows:

Run Mode: Triggered

Trigger Source: INT

Trigger Mode: Timer

Timer: As required for the tests

Outputs: On

Test Procedure

1. Perform timed internal trigger tests using *Table 5-32*.

Table 5-32: Trigger Delay Tests

81180A Delay Setting	Error Limits	Counter Reading		Pass	Fail
		CH1	CH2		
200 ns	200 ns, $\pm 0.01$ ns				
100 $\mu$ s	100 $\mu$ s, $\pm 10$ ns				
100 ms	100 ms, $\pm 10$ $\mu$ s				

#### 5.14.5 Delayed Internal Trigger Tests

##### Delayed Internal Trigger Tests

Equipment: Counter

Preparation:

1. Connect the 81180A outputs to channel 1 input of the counter.
2. Configure the counter to pulse width. Set channel 1 slope to negative.

3. Configure the 81180A as follows:
  - Function: Arbitrary
  - SCLK: 4.2 GSa/s
  - Waveform: Square, 1024 points, 1 cycle
  - Run Mode: Triggered
  - Trigger Source: INT
  - Trigger Mode: Delay
  - Delay: As required for the tests
  - Outputs: On

Test Procedure

1. Perform delayed internal trigger tests using *Table 5-33*.

**Table 5-33: Trigger Delay Tests**

81180A Delay Setting	Error Limits	Counter Reading		Pass	Fail
		CH1	CH2		
1,024	365.7 ns, $\pm 2$ ns				
10,240	2560 ns, $\pm 2$ ns				
102,400	24503 ns, $\pm 2$ ns				

## 5.15 Marker Output Characteristics

### Marker Output Characteristics

This tests the operation of the markers. There are two markers for each channel and these are programmed as part of the waveform data. The markers can be programmed to have variable length, delay and amplitude and each can be skewed in reference to one another in increments of 10 ps. The function of the markers is tested in this section. Perform the following tests if you suspect that the markers do not perform as expected.

### 5.15.1 Marker Output and Level Checks

#### Marker Output and Level Checks

Equipment: Oscilloscope  
Preparation:

1. Configure the oscilloscope follows:  
Setup: As required for the test
2. Connect 81180A marker outputs to the oscilloscope inputs.
3. Configure the 81180A as follows:

Outputs: On  
 Markers: On  
 Test Procedure

1. Check the marker outputs and levels using *Table 5-34* and *Table 5-35*.

**Table 5-34: Channel 1 Marker Output and Level Tests**

CH1 Markers Amplitude Setting		Error Limits	Oscilloscope Reading		Pass	Fail
Low	High		Marker 1	Marker 2		
0 V	0.5 V	0.5 V, $\pm 50$ mV				
0 V	1.25V	1.25 V, $\pm 125$ mV				
0.5 V	1 V	0.5 V, $\pm 50$ mV				
0.8 V	1.25 V	0.45 V, $\pm 45$ mV				

**Table 5-35: Channel 2 Marker Output and Level Tests**

CH2 Markers Amplitude Setting		Error Limits	Oscilloscope Reading		Pass	Fail
Low	High		Marker 1	Marker 2		
0 V	0.5 V	0.5 V, $\pm 50$ mV				
0 V	1.25V	1.25 V, $\pm 125$ mV				
0.5 V	1 V	0.5 V, $\pm 50$ mV				
0.8 V	1.25 V	0.45 V, $\pm 45$ mV				

### 5.15.2 Marker Delay Checks

**Marker Delay  
Checks**

Equipment: Oscilloscope  
 Preparation:

1. Configure the oscilloscope as required by the test.
2. Connect 81180A main outputs to the oscilloscope input – channel 1.
3. Connect the 81180A marker outputs to the oscilloscope – channel 2.
4. Configure the 81180A as follows:

Outputs: On  
 Waveform: Square  
 Markers: On

Delay: As required by the tests

Test Procedure

1. Check the marker delay using *Table 5-36* and *Table 5-37*. The delay is referenced to the channel output. Note that there is a constant delay between the outputs and the markers that must be considered as part of the accuracy limits. It is important to verify that the skew between the markers with the same delay setting is <100 ps.
2. Note and record the initial delay with the 81180A marker delay set to 0 points. Always add the initial delay value to the actual result. Typically, the initial marker delay is less than 3.5 ns.

**Table 5-36: Channel 1 Marker delay Tests**

Marker Delay Setting		Error Limits	Oscilloscope Reading		Pass	Fail
Marker 1	Marker 2		Marker 1	Marker 2		
0	0	Reference, <3.2 ns				
500 ps	500 ps	Ref + 500 ps, ±70 ps				
1 ns	1 ns	Ref + 1 ns, ±120 ps				
3 ns	3 ns	Ref + 3 ns, ±320 ps				

**Table 5-37: Channel 2 Marker Delay Tests**

Marker Delay Setting		Error Limits	Oscilloscope Reading		Pass	Fail
Marker 1	Marker 2		Marker 1	Marker 2		
0	0	Reference, <3.2 ns				
500 ps	500 ps	Ref + 500 ps, ±70 ps				
1 ns	1 ns	Ref + 1 ns, ±120 ps				
3 ns	3 ns	Ref + 3 ns, ±320 ps				

### 5.15.3 Marker Position Checks

**Marker Position Checks**

Equipment: Oscilloscope

Preparation:

1. Configure the oscilloscope as required by the test.
2. Connect 81180A main output to the oscilloscope – channel 1.
3. Connect the marker outputs to the oscilloscope – channel 2.
4. Configure the 81180A as follows:

Function: Arbitrary

SCLK: 4.2 GSa/s

Waveform: Square, 1,024,000 points, 1 cycle

Outputs: On

Markers: On

Marker Position: As required by the tests

#### Test Procedure

1. Check the marker position using *Table 5-38* and *Table 5-39*. The position is referenced to the channel output. Note that there is a constant delay between the outputs and the markers that must be considered as part of the accuracy limits. The position in reference to the output waveform is programmed in units of sample clock periods (or waveform points).
2. Note and record the marker position with the 81180A marker position set to 0 points. Always add the initial delay value to the actual result. Typically, the initial marker position delay is less than 3.5 ns.

**Table 5-38: Channel 1 Marker Position Tests**

Marker Position Setting		Error Limits	Oscilloscope Reading		Pass	Fail
Marker 1	Marker 2		Marker 1	Marker 2		
0	0	Reference, <3.2 ns				
1,024	1,024	Ref + 243.8 ns, $\pm 2$ ns				
10,240	10,240	Ref + 2438 ns, $\pm 2$ ns				
102,400	102,400	Ref + 24381 ns, $\pm 2$ ns				

**Table 5-39: Channel 2 Marker Position Tests**

Marker Position Setting		Error Limits	Oscilloscope Reading		Pass	Fail
Marker 1	Marker 2		Marker 1	Marker 2		
0	0	Reference, <3.2 ns				
1,024	1,024	Ref + 243.8 ns, $\pm 2$ ns				
10,240	10,240	Ref + 2438 ns, $\pm 2$ ns				
102,400	102,400	Ref + 24381 ns, $\pm 2$ ns				

## 5.15.4 Marker Width Checks

**Marker Width Checks** Equipment: Oscilloscope

Preparation:

1. Configure the oscilloscope as required by the test.
2. Connect 81180A marker outputs to the oscilloscope input.
3. Configure the 81180A as follows:

Function: Arbitrary

SCLK: 4.2 GSa/s

Waveform: Square, 1,024,000 points, 1 cycle

Outputs: On

Markers: On

Marker Width: As required by the tests

Test Procedure

1. Check the marker width using *Table 5-40* and *Table 5-41*. The width is programmed in units of sample clock periods (or waveform points).

**Table 5-40: Channel 1 Marker Width Tests**

Marker Width Setting		Error Limits	Oscilloscope Reading		Pass	Fail
Marker 1	Marker 2		Marker 1	Marker 2		
40	40	9.5 ns, $\pm 1$ ns				
1,024	1,024	243.8 ns, $\pm 1$ ns				
10,240	10,240	2438 ns, $\pm 1$ ns				
102,400	102,400	24381 ns, $\pm 1$ ns				

**Table 5-41: Channel 2 Marker Width Tests**

Marker Width Setting		Error Limits	Oscilloscope Reading		Pass	Fail
Marker 1	Marker 2		Marker 1	Marker 2		
40	40	9.5 ns, $\pm 1$ ns				
1,024	1,024	243.8 ns, $\pm 1$ ns				
10,240	10,240	2438 ns, $\pm 1$ ns				
102,400	102,400	24381 ns, $\pm 1$ ns				

## 5.16 SYNC Output Operation

**SYNC Output Operation** This tests the operation of the SYNC output. There are four parameters being tested: Type, Source, Position and Width. The sync output has fixed TTL level amplitude into an open circuit. Perform the SYNC Output Operation tests if you suspect that the SYNC output does not perform as expected.

---

### 5.16.1 SYNC Output – Pulse

**SYNC Output – Pulse** Equipment: Oscilloscope

Preparation:

1. Configure the oscilloscope as follows:

Setup: As required by the test

Trigger Source: Channel 2

2. Connect 81180A channel 1 output to the oscilloscope input

3. Connect 81180A SYNC output to the oscilloscope channel 2 input

4. Configure model 81180A as follows:

CH1 Output: On

SYNC: On

Test Procedure:

1. Verify trace on the oscilloscope shows sine waveforms and synchronization pulses at 100 ns intervals and pulse width is roughly 7 ns.
- 

Test Results	Pass		Fail	
--------------	------	--	------	--

### 5.16.2 SYNC Output - WCOM

**SYNC Output - WCOM** Equipment: Oscilloscope

Preparation:

1. Configure the oscilloscope as follows:

Setup: As required by the test

Trigger Source: Channel 2

2. Connect 81180A channel 1 output to the oscilloscope input

3. Connect 81180A SYNC output to the oscilloscope channel 2 input

4. Configure model 81180A as follows:

CH1 Output: On  
 SYNC: On  
 Run Mode: Triggered  
 Trigger Source: Internal  
 Trigger Count: 5

**Test Procedure:**

1. Verify trace on the oscilloscope shows sine waveforms and synchronization pulses. Verify that the SYNC pulse transitions to high level at the start address and transitions to low level at the end of the waveform.

Test Results	Pass		Fail	
--------------	------	--	------	--

### 5.16.3 SYNC Source

**SYNC Source**

Equipment: Oscilloscope

**Preparation:**

1. Configure the oscilloscope as follows:

Setup: As required by the test

Trigger Source: Channel 1

2. Connect 81180A SYNC output to the oscilloscope input, channel 1
3. Connect 81180A channel 1 output to the oscilloscope input, channel 2
4. Connect 81180A channel 2 output to the oscilloscope input, channel 3
5. Configure model 81180A channel 1 and 2 controls as follows:

Function: Arbitrary

Waveform CH1: Sine, 256 points, 1 cycle

Waveform CH2: Sine, 1026 points, 1 cycle

Output: On

SYNC: On

**Test Procedure:**

1. Verify that the trace on the oscilloscope is synchronized with the 81180A channel 1 waveform

Test Results	Pass		Fail	
--------------	------	--	------	--

2. Modify the 81180A SYNC Source from channel 1 to channel 2



- Verify that the trace on the oscilloscope is synchronized with the 81180A channel 2 waveform

Test Results	Pass		Fail	
--------------	------	--	------	--

#### 5.16.4 SYNC Position Checks

##### SYNC Position Checks

Equipment: Oscilloscope

Preparation:

- Configure the oscilloscope as required by the test.
- Connect 81180A main output to the oscilloscope – channel 1.
- Connect 81180A SYNC output to the oscilloscope – channel 2.
- Configure the 81180A as follows:

Function: Arbitrary

SCLK: 4.2 GSa/s

Waveform: Square, 1,024,000 points, 1 cycle

CH1 Output: On

SYNC: On

SYNC Position: As required by the tests

Test Procedure

- Check the SYNC position using *Table 5-42*. The position is referenced to the channel output. Note that there is a constant delay between the outputs and the SYNC that must be considered as part of the accuracy limits. The position in reference to the output waveform is programmed in units of sample clock periods (or waveform points).
- Note and record the SYNC position with the 81180A SYNC position set to 0 points. Always add the initial delay value to the actual result. Typically, the initial SYNC position delay is less than 3.5 ns.

**Table 5-42: SYNC Position Tests**

SYNC Position Setting	Error Limits	Oscilloscope Reading	Pass	Fail
0	Reference, <3.5 ns			
1,024	Ref + 243.8 ns, $\pm 2$ ns			
10,240	Ref + 2438 ns, $\pm 2$ ns			
102,400	Ref + 24381 ns, $\pm 2$ ns			

## 5.16.5 SYNC Width Checks

**SYNC Width Checks** Equipment: Oscilloscope

Preparation:

1. Configure the oscilloscope as required by the test.
2. Connect 81180A SYNC output to the oscilloscope input.
3. Configure the 81180A as follows:

Function: Arbitrary

SCLK: 4.2 GSa/s

Waveform: Square, 1,024,000 points, 1 cycle

CH1 Output: On

SYNC: On

SYNC Width: As required by the tests

Test Procedure

1. Check the SYNC width using *Table 5-43*. The width is programmed in units of sample clock periods (or waveform points).

---

**Table 5-43: SYNC Width Tests**

SYNC Width Setting	Error Limits	Oscilloscope Reading	Pass	Fail
32	7.6 ns, $\pm 2$ ns			
1,024	243.8 ns, $\pm 2$ ns			
10,240	2438 ns, $\pm 2$ ns			
102,400	24381 ns, $\pm 2$ ns			

## 5.17 Waveform Memory Operation

**Waveform Memory Operation**

This tests the integrity of the waveform memory and the control of the individual memory segments. The waveform memory stores the waveforms that are being generated at the output connector and therefore, flaws in the memory can cause distortions and impurity of the output waveforms. Each channel has its own working memory and therefore each channel is tested separately. Perform the waveform memory operation tests if you suspect that there are problems with the arbitrary waveform memory.

---

### 5.17.1 Waveform Memory

**Waveform Memory** Equipment: Oscilloscope

Preparation:

1. Connect 81180A outputs to the oscilloscope inputs. Configure the 81180A as follows:

Function: Arbitrary

SCLK: 4.2 GSa/s

Waveform: Sine, 16 M/64 M points, 1 cycle

Outputs: On

2. Using 'BenchLink Waveform Builder Pro', build and download four segments to the 81180A, each 16M long:

Segment 1: Sine waveform, 16 M points, 1 cycle

Segment 2: Triangle waveform, 16 M points, 1 cycle

Segment 3: Square waveform, 16 M points, 1 cycle

Segment 4: Sinc waveform, 16 M points, 1 cycle

Test Procedure

1. Set the oscilloscope to "Glitch Detect" and vary oscilloscope delay and offset to check flaws in the waveform shape. Do this on each of the four waveform segments.

---

Test Results	Pass		Fail	
--------------	------	--	------	--

### 5.17.2 Internal Waveform

**Internal Waveform** Equipment: Oscilloscope

Preparation:

1. Connect 81180A outputs to the oscilloscope inputs. Configure the 81180A as follows:

Function: Arbitrary

SCLK: 4.2 GSa/s

Segment 1: Sine, 1,024 points, 1 cycle

Segment 2: Square, 1,024 points, 1 cycle

Segment 3: Triangle, 1,024 points, 1 cycle

Segment 4: Ramp, 1,024 points, 1 cycle

Segment 5: SINC, 1,024 points, 1 cycle

Outputs: On

Test Procedure

1. Select segments 1 through 5 and observe that the shape changes on the oscilloscope as programmed for each segment.

---

Test Results	Pass		Fail	
--------------	------	--	------	--

### 5.17.3 Dynamic Waveform Control

**Dynamic Waveform** Equipment: Oscilloscope

**Control**

Preparation:

1. Connect 81180A outputs to the oscilloscope inputs. Configure the 81180A as follows:

Function: Arbitrary

SCLK: 4.2 GSa/s

Segment 1: Sine, 1,024 points, 1 cycle

Segment 2: Square, 1,024 points, 1 cycle

Segment 4: Triangle, 1,024 points, 1 cycle

Segment 8: Ramp, 1,024 points, 1 cycle

Segment 16: SINC, 1,024 points, 1 cycle

Segment 32: Gaussian, 1,024 points, 10 cycle

Segment 64: Triangle, 1,024 points, 10 cycle

Segment 128: SINC, 1,024 points, 10 cycle

Outputs: On

## Jump Event: External

## Test Procedure

1. Connect the test box to the rear-panel Sequence/Segment Control input.
2. Using the test box, select segments 1, 2, 4, 8, 16, 32, 64, 128 and observe that the shape changes on the oscilloscope, every time that a valid line is asserted, as programmed for each segment.

---

Test Results	Pass		Fail	
--------------	------	--	------	--

## 5.18 Sequence operation

**Sequence operation** This tests the operation of the sequence generators. Each channel has its own sequence generator and therefore operations are tested on each channel separately. The sequence generators are being checked in all run and advance mode options.

---

### 5.18.1 Continuous Sequence - Auto Advance Mode

**Continuous Sequence** Equipment: Counter, Function Generator

- **Auto Advance Mode** Preparation:

1. Configure the Counter as follows:  
Function: FREQ 1 Measurement
2. Connect the counter input to the 81180A channel 1 output
3. Configure the function generator as follows:  
Waveform: Square  
Run Mode: Triggered
4. Connect the function generator output to the 81180A rear panel event input
5. Configure the 81180A as follows (both channels):  
Function: Sequence  
SCLK: 4.2 GSa/s  
CH1/2 Outputs: On
6. Using 'BenchLink Waveform Builder Pro', prepare and download the following waveform to both channels:

- Segment 1: 320 points, 1 cycle square
  - Segment 2: 512 points, 1 cycle square
  - Segment 3: 1,024 points, 1 cycle square
  - Segment 4: 2,048 points, 1 cycle square
  - Segment 5: 4,096 points, 1 cycle square
7. Using 'BenchLink Waveform Builder Pro', build and download the following sequence table:

- Step 1: Segment 1, Repeat = 10, Jump Flag = 1
- Step 2: Segment 2, Repeat = 10, Jump Flag = 1
- Step 3: Segment 3, Repeat = 10, Jump Flag = 1
- Step 4: Segment 4, Repeat = 10, Jump Flag = 1
- Step 5: Segment 5, Repeat = 10, Jump Flag = 1

**Test Procedure**

1. Check channel 1 and then channel 2 sequence operation using *Table 5-44*.

**Table 5-44: Continuous Sequence - Auto Advance Tests**

Step	External Events	Error Limits	Counter Reading		Pass	Fail
			CH1	CH2		
1	Idle	13.125 MHz, $\pm 13.125$ Hz				
2	Event 1	8.2031250 MHz, $\pm 8.2$ Hz				
3	Event 2	4.1015625 MHz, $\pm 4.1$ Hz				
4	Event 3	2.0507813 MHz, $\pm 2.05$ Hz				
5	Event 4	1.0253906 MHz, $\pm 1.025$ Hz				
6	Event 5	13.125 MHz, $\pm 13.125$ Hz				

**5.18.2 Continuous Sequence - Once Advance Mode**

**Continuous Sequence** Equipment: Counter, Function Generator

- **Once Advance Mode** Preparation:

1. Configure the Counter as follows:  
Function: FREQ 1 Measurement
2. Connect the counter input to the 81180A channel 1 output
3. Configure the function generator as follows:

Waveform: Square

Run Mode: Triggered

4. Connect the function generator output to the 81180A rear panel event input

5. Configure the 81180A as follows (both channels):

Function: Sequence

Advance Mode: Once

SCLK: 4.2 GSa/s

CH1/2 Outputs: On

6. Using 'BenchLink Waveform Builder Pro', prepare and download the following waveform to both channels:

Segment 1: 1,024 points, 1 cycle square

Segment 2: 102,400 points, 1 cycle square

Segment 3: 102,400 points, 1 cycle square

Segment 4: 102,400 points, 1 cycle square

Segment 5: 102,400 points, 1 cycle square

7. Using 'BenchLink Waveform Builder Pro', build and download the following sequence table:

Step 1: Segment 1, Repeat = 1, Jump Flag = 0

Step 2: Segment 2, Repeat = 100, Jump Flag = 0

Step 3: Segment 3, Repeat = 1,000, Jump Flag = 0

Step 4: Segment 4, Repeat = 100,000, Jump Flag = 0

Step 5: Segment 5, Repeat = 200,000, Jump Flag = 0

#### Test Procedure

1. Check channel 1 and then channel 2 sequence operation using *Table 5-45*. Note that counter frequency measurement after an enable operation must be done within 1 second and last measurement after the sequence resumes idling must be delayed for at least 5 seconds.

**Table 5-45: Continuous Sequence - Once Advance Tests**

External Control	Error Limits	Counter Reading		Pass	Fail
		CH1	CH2		
Idle	4.1015625 MHz, $\pm 4.1$ Hz				
Event	41.015625 kHz, $\pm 41$ mHz				
Idle	4.1015625 MHz, $\pm 4.1$ Hz				

### 5.18.3 Continuous Sequence - Stepped Advance Mode

**Continuous Sequence** Equipment: Counter, Function Generator

**- Stepped Advance Mode** Preparation:

1. Configure the Counter as follows:  
Function: FREQ 1 Measurement
2. Connect the counter input to the 81180A channel 1 output
3. Configure the function generator as follows:  
Waveform: Square  
Run Mode: Triggered
4. Connect the function generator output to the 81180A event input
5. Configure the 81180A as follows (both channels):  
Function: Sequence  
Advance Mode: Stepped  
SCLK: 4.2 GSa/s  
CH1/2 Outputs: On
6. Using 'BenchLink Waveform Builder Pro', prepare and download the following waveform to both channels:  
Segment 1: 320 points, 1 cycle square  
Segment 2: 512 points, 1 cycle square  
Segment 3: 1,024 points, 1 cycle square  
Segment 4: 2,048 points, 1 cycle square  
Segment 5: 4,096 points, 1 cycle square
7. Using 'BenchLink Waveform Builder Pro', build and download the following sequence table:  
Step 1: Segment 1, Repeat = 1, Jump Flag = 0  
Step 2: Segment 2, Repeat = 1, Jump Flag = 0  
Step 3: Segment 3, Repeat = 1, Jump Flag = 0  
Step 4: Segment 4, Repeat = 1, Jump Flag = 0  
Step 5: Segment 5, Repeat = 1, Jump Flag = 0

Test Procedure

1. Check channel 1 and then channel 2 sequence operation using *Table 5-46*.
-



Table 5-46: Continuous Sequence - Stepped Advance Tests

Function Generator	Error Limits	Counter Reading		Pass	Fail
		CH1	CH2		
Idle	13.125 MHz, $\pm 13.125$ Hz				
Event 1	8.2031250 MHz, $\pm 8.2$ Hz				
Event 2	4.1015625 MHz, $\pm 4.1$ Hz				
Event 3	2.0507813 MHz, $\pm 2.05$ Hz				
Event 4	1.0253906 MHz, $\pm 1.025$ Hz				
Event 5	13.125 MHz, $\pm 13.125$ Hz				

#### 5.18.4 Triggered Sequence - Auto Advance Mode

**Triggered Sequence** - Equipment: Counter, Function Generator

**Auto Advance Mode** Preparation:

- Configure the Counter as follows:  
Function: FREQ 1 Measurement
- Connect the counter input to the 81180A channel 1 output
- Configure the function generator as follows:  
Waveform: Square  
Run Mode: Triggered
- Connect the function generator output to the 81180A trigger input
- Configure the 81180A as follows (both channels):  
Function: Sequence  
Run Mode: Triggered  
SCLK: 4.2 GSa/s  
CH1/2 Outputs: On
- Using 'BenchLink Waveform Builder Pro', prepare and download the following waveform to both channels:  
Segment 1: 320 points, 1 cycle square  
Segment 2: 320 points, 1 cycle square  
Segment 3: 320 points, 1 cycle square  
Segment 4: 320 points, 1 cycle square  
Segment 5: 320 points, 1 cycle square
- Using 'BenchLink Waveform Builder Pro', build and download the following sequence table:  
Step 1: Segment 1, Repeat = 10, Jump Flag = 0

- Step 2: Segment 2, Repeat = 100, Jump Flag = 0
- Step 3: Segment 3, Repeat = 1,000, Jump Flag = 0
- Step 4: Segment 4, Repeat = 10,000, Jump Flag = 0
- Step 5: Segment 5, Repeat = 100,000, Jump Flag = 0

Test Procedure

1. Check channel 1 and then channel 2 sequence operation using *Table 5-47*.

**Table 5-47: Triggered Sequence - Auto Advance Tests**

Remote Enable	Error Limits	Counter Reading		Pass	Fail
		CH1	CH2		
Idle	DC, no reading				
Trigger	13.125 MHz, $\pm 13.125$ Hz				

### 5.18.5 Triggered Sequence - Once Advance Mode

**Triggered Sequence** - Equipment: Counter, Function Generator

**Once Advance Mode** Preparation:

1. Configure the Counter as follows:  
Function: Totalized 1 Measurement
2. Connect the counter input to the 81180A channel 1 output
3. Configure the function generator as follows:  
Waveform: Square  
Run Mode: Triggered
4. Connect the function generator output to the 81180A trigger input
5. Configure the 81180A as follows (both channels):  
Function: Sequence  
Advance Mode: Once  
SCLK: 4.2 GSa/s  
CH1/2 Outputs: On
6. Using 'BenchLink Waveform Builder Pro', prepare and download the following waveform to both channels:  
Segment 1: 320 points, 1 cycle square  
Segment 2: 320 points, 1 cycle square  
Segment 3: 320 points, 1 cycle square

Segment 4: 320 points, 1 cycle square

Segment 5: 320 points, 1 cycle square

7. Using 'BenchLink Waveform Builder Pro', build and download the following sequence table:

Step 1: Segment 1, Repeat = 10, Jump Flag = 0

Step 2: Segment 2, Repeat = 100, Jump Flag = 0

Step 3: Segment 3, Repeat = 1,000, Jump Flag = 0

Step 4: Segment 4, Repeat = 10,000, Jump Flag = 0

Step 5: Segment 5, Repeat = 100,000, Jump Flag = 0

**Test Procedure**

1. Check channel 1 and then channel 2 sequence operation using *Table 5-48*.

**Table 5-48: Triggered Sequence - Once Advance Tests**

Remote Enable	Error Limits	Counter Reading		Pass	Fail
		CH1	CH2		
Trigger	111,110, $\pm 0$				

**Triggered Sequence** - Equipment: Counter, Function Generator

**Stepped Advance Mode** Preparation:

1. Configure the Counter as follows:

Function: FREQ 1 Measurement

2. Connect the counter input to the 81180A channel 1 output

3. Configure the function generator as follows:

Waveform: Square

Run Mode: Triggered

4. Connect the function generator output to the 81180A trigger input

5. Configure the 81180A as follows (both channels):

Function: Sequence

Advance Mode: Stepped

SCLK: 200 MSa/s

CH1/2 Outputs: On

6. Using 'BenchLink Waveform Builder Pro', prepare and download the following waveform to both channels:

Segment 1: 320 points, 1 cycle square

- Segment 2: 512 points, 1 cycle square
  - Segment 3: 1,024 points, 1 cycle square
  - Segment 4: 2,048 points, 1 cycle square
  - Segment 5: 4,096 points, 1 cycle square
7. Using 'BenchLink Waveform Builder Pro', build and download the following sequence table:
- Step 1: Segment 1, Repeat = 1 M, Jump Flag = 0
  - Step 2: Segment 2, Repeat = 1 M, Jump Flag = 0
  - Step 3: Segment 3, Repeat = 700,000, Jump Flag = 0
  - Step 4: Segment 4, Repeat = 200,000, Jump Flag = 0
  - Step 5: Segment 5, Repeat = 100,000, Jump Flag = 0

**Test Procedure**

1. Check channel 1 and then channel 2 sequence operation using *Table 5-49*. Note that counter frequency measurement after a trigger operation must be done within 1 second.

**Table 5-49: Triggered Sequence - Stepped Advance Tests**

Function Generator	Error Limits	Counter Reading		Pass	Fail
		CH1	CH2		
Trigger 1	625 kHz, ±625 mHz				
Trigger 2	390.62500 kHz, ±391 mHz				
Trigger 3	195.31250 kHz, ±195 mHz				
Trigger 4	97.656250 kHz, ±97.7 mHz				
Trigger 5	48.828125 kHz, ±48.8 mHz				
Trigger 6	625 kHz, ±625 mHz				

## 5.19 Advanced Sequence operation

**Advanced Sequence operation** This tests the operation of the advanced sequence generators. Each channel has its own advanced sequence generator and therefore operations are tested on each channel separately. The advanced sequence generators are being checked in all run and advance mode options.

### 5.19.1 Continuous Advanced Sequence - Auto Advance Mode

**Continuous Advanced** Equipment: Counter, Function Generator

**Sequence - Auto Advance Mode**

Preparation:

1. Configure the Counter as follows:

Function: FREQ 1 Measurement

2. Connect the counter input to the 81180A channel 1 output

3. Configure the function generator as follows:

Waveform: Square

Run Mode: Triggered

4. Connect the function generator output to the 81180A rear panel event input

5. Configure the 81180A as follows (both channels):

Function: Advanced Sequence

SCLK: 4.2 GSa/s

CH1/2 Outputs: On

6. Using 'BenchLink Waveform Builder Pro', prepare and download the following waveform to both channels:

Segments 1, 2 and 3: 320 points, 1 cycle square

Segments 4, 5 and 6: 512 points, 1 cycle square

Segments 7, 8 and 9: 1,024 points, 1 cycle square

Segments 10, 11 and 12: 2,048 points, 1 cycle square

Segments 13, 14 and 15: 4,096 points, 1 cycle square

7. Using 'BenchLink Waveform Builder Pro', build and download the following sequence table:

Sequence 1:

Steps 1, 2 and 3: Segments 1, 2 and 3, Repeat = 10, Jump Flag = 0

Sequence 2:

Steps 1, 2 and 3: Segments 4, 5 and 6, Repeat = 10, Jump Flag = 0

Sequence 3:

Steps 1, 2 and 3: Segments 7, 8 and 9, Repeat = 10, Jump Flag = 0

Sequence 4:

Steps 1, 2 and 3: Segments 10, 11 and 12, Repeat = 10, Jump Flag = 0

Sequence 5:

Steps 1, 2 and 3: Segments 13, 14 and 15, Repeat = 10, Jump Flag = 0

8. Using 'BenchLink Waveform Builder Pro', build and download the following Advanced sequence table:

Step 1: Sequence 1, Repeat = 1, Jump Flag = 1

Step 2: Sequence 2, Repeat = 1, Jump Flag = 1

Step 3: Sequence 3, Repeat = 1, Jump Flag = 1

Step 4: Sequence 4, Repeat = 1, Jump Flag = 1

Step 5: Sequence 5, Repeat = 1, Jump Flag = 1

Test Procedure

1. Check channel 1 and then channel 2 advanced sequence operation using *Table 5-50*. Each trigger at the event input modifies the advanced sequence generator to the next sequence.

**Table 5-50: Continuous Advanced Sequence - Auto Advance Tests**

Step	External Events	Error Limits	Counter Reading		Pass	Fail
			CH1	CH2		
1	Idle	13.125 MHz, $\pm 13.125$ Hz				
2	Event 1	8.2031250 MHz, $\pm 8.2$ Hz				
3	Event 2	4.1015625 MHz, $\pm 4.1$ Hz				
4	Event 3	2.0507813 MHz, $\pm 2.05$ Hz				
5	Event 4	1.0253906 MHz, $\pm 1.025$ Hz				
6	Event 5	13.125 MHz, $\pm 13.125$ Hz				

### 5.19.2 Continuous Advanced Sequence - Once Advance Mode

**Continuous Advanced** Equipment: Counter, Function Generator

**Sequence - Once Advance Mode**

Preparation:

1. Configure the Counter as follows:  
Function: FREQ 1 Measurement
2. Connect the counter input to the 81180A channel 1 output
3. Configure the function generator as follows:  
Waveform: Square  
Run Mode: Triggered
4. Connect the function generator output to the 81180A rear panel event input
5. Configure the 81180A as follows (both channels):  
Function: Advanced Sequence  
Advance Mode: Once  
SCLK: 4.2 GSa/s  
CH1/2 Outputs: On
6. Using 'BenchLink Waveform Builder Pro', prepare and download the following waveform to both channels:

Segments 1, 2 and 3:	1,024 points, 1 cycle square
Segments 4, 5 and 6:	102,400 points, 1 cycle square
Segments 7, 8 and 9:	102,400 points, 1 cycle square
Segments 10, 11 and 12:	102,400 points, 1 cycle square
Segments 13, 14 and 15:	102,400 points, 1 cycle square

7. Using 'BenchLink Waveform Builder Pro', build and download the following sequence table:

Sequence 1:

Steps 1, 2 and 3: Segments 1, 2 and 3, Repeat = 10, Jump Flag = 0

Sequence 2:

Steps 1, 2 and 3: Segments 4, 5 and 6, Repeat = 1,000, Jump Flag = 0

Sequence 3:

Steps 1, 2 and 3: Segments 7, 8 and 9, Repeat = 1,000, Jump Flag = 0

Sequence 4:

Steps 1, 2 and 3: Segments 10, 11 and 12, Repeat = 1,000, Jump Flag = 0

Sequence 5:

Steps 1, 2 and 3: Segments 13, 14 and 15, Repeat = 1,000, Jump Flag = 0

8. Using 'BenchLink Waveform Builder Pro', build and download the following Advanced sequence table:

Step 1: Sequence 1, Repeat = 1, Jump Flag = 0

Step 2: Sequence 2, Repeat = 20, Jump Flag = 0

Step 3: Sequence 3, Repeat = 20, Jump Flag = 0

Step 4: Sequence 4, Repeat = 20, Jump Flag = 0

Step 5: Sequence 5, Repeat = 20, Jump Flag = 0

#### Test Procedure

1. Check channel 1 and then channel 2 advanced sequence operation using *Table 5-51*. Each trigger at the event input modifies the advanced sequence generator to the next sequence.

**Table 5-51: Continuous Advanced Sequence - Once Advance Tests**

External Controls	Error Limits	Counter Reading		Pass	Fail
		CH1	CH2		
Idle	4.1015625 MHz, $\pm 4.1$ Hz				
Event	41.015625 kHz, $\pm 41$ mHz				
Idle	4.1015625 MHz, $\pm 4.1$ Hz				

### 5.19.3 Continuous Advanced Sequence - Stepped Advance Mode

**Continuous Advanced** Equipment: Counter, Function Generator

**Sequence - Stepped** Preparation:

**Advance Mode**

1. Configure the Counter as follows:  
Function: FREQ 1 Measurement
2. Connect the counter input to the 81180A channel 1 output
3. Configure the function generator as follows:  
Waveform: Square  
Run Mode: Triggered
4. Connect the function generator output to the 81180A event input
5. Configure the 81180A as follows (both channels):  
Function: Advanced Sequence  
Advance Mode: Stepped  
SCLK: 4.2 GSa/s  
CH1/2 Outputs: On
6. Using 'BenchLink Waveform Builder Pro', prepare and download the following waveform to both channels:  
Segments 1, 2 and 3: 320 points, 1 cycle square  
Segments 4, 5 and 6: 512 points, 1 cycle square  
Segments 7, 8 and 9: 1,024 points, 1 cycle square  
Segments 10, 11 and 12: 2,048 points, 1 cycle square  
Segments 13, 14 and 15: 4,096 points, 1 cycle square
7. Using 'BenchLink Waveform Builder Pro', build and download the following sequence table:  
Sequence 1:  
Steps 1, 2 and 3: Segments 1, 2 and 3, Repeat = 10, Jump Flag = 0  
Sequence 2:  
Steps 1, 2 and 3: Segments 4, 5 and 6, Repeat = 10, Jump Flag = 0  
Sequence 3:  
Steps 1, 2 and 3: Segments 7, 8 and 9, Repeat = 10, Jump Flag = 0



Sequence 4:

Steps 1, 2 and 3: Segments 10, 11 and 12, Repeat = 10, Jump Flag = 0

Sequence 5:

Steps 1, 2 and 3: Segments 13, 14 and 15, Repeat = 10, Jump Flag = 0

8. Using 'BenchLink Waveform Builder Pro', build and download the following Advanced sequence table:

Step 1: Sequence 1, Repeat = 1, Jump Flag = 0

Step 2: Sequence 2, Repeat = 1, Jump Flag = 0

Step 3: Sequence 3, Repeat = 1, Jump Flag = 0

Step 4: Sequence 4, Repeat = 1, Jump Flag = 0

Step 5: Sequence 5, Repeat = 1, Jump Flag = 0

Test Procedure

1. Check channel 1 and then channel 2 advanced sequence operation using *Table 5-52*. Each trigger at the event input modifies the advanced sequence generator to the next sequence.

**Table 5-52: Continuous Advanced Sequence – Stepped Advance Tests**

Step	External Events	Error Limits	Counter Reading		Pass	Fail
			CH1	CH2		
1	Idle	13.125 MHz, $\pm 13.125$ Hz				
2	Event 1	8.2031250 MHz, $\pm 8.2$ Hz				
3	Event 2	4.1015625 MHz, $\pm 4.1$ Hz				
4	Event 3	2.0507813 MHz, $\pm 2.05$ Hz				
5	Event 4	1.0253906 MHz, $\pm 1.025$ Hz				
6	Event 5	13.125 MHz, $\pm 13.125$ Hz				

#### 5.19.4 Triggered Advanced Sequence - Auto Advance Mode

**Triggered Advanced Sequence - Auto Advance Mode** Equipment: Counter, Function Generator

Preparation:

1. Configure the Counter as follows:  
Function: FREQ 1 Measurement
2. Connect the counter input to the 81180A channel 1 output
3. Configure the function generator as follows:

Waveform: Square

Run Mode: Triggered

4. Connect the function generator output to the 81180A trigger input
5. Configure the 81180A as follows (both channels):
  - Function: Advanced Sequence
  - Run Mode: Triggered
  - SCLK: 4.2 GSa/s
  - CH1/2 Outputs: On
6. Using 'BenchLink Waveform Builder Pro', prepare and download the following waveform to both channels:
  - Segments 1 to 15: 320 points, 1 cycle square
7. Using 'BenchLink Waveform Builder Pro', build and download five identical sequence tables:
  - Step 1: Segments 1, 4, 7, 10 and 13, Repeat = 10, Jump Flag = 0
  - Step 2: Segment 2, 5, 8, 11 and 14, Repeat = 10, Jump Flag = 0
  - Step 3: Segment 3, 6, 9, 12 and 15, Repeat = 10, Jump Flag = 0
8. Using 'BenchLink Waveform Builder Pro', build and download the following Advanced sequence table:
  - Step 1: Sequence 1, Repeat = 10, Jump Flag = 0
  - Step 2: Sequence 2, Repeat = 100, Jump Flag = 0
  - Step 3: Sequence 3, Repeat = 1,000, Jump Flag = 0
  - Step 4: Sequence 4, Repeat = 10,000, Jump Flag = 0
  - Step 5: Sequence 5, Repeat = 100,000, Jump Flag = 0

**Test Procedure**

1. Check channel 1 and then channel 2 advanced sequence operation using *Table 5-53*.

**Table 5-53: Triggered Advanced Sequence - Auto Advance Tests**

Remote Enable	Error Limits	Counter Reading		Pass	Fail
		CH1	CH2		
Idle	DC, no reading				
Trigger	13.125 MHz, $\pm 13.125$ Hz				

### 5.19.5 Triggered Advanced Sequence - Once Advance Mode

#### Triggered Advanced Sequence - Once Advance Mode

Equipment: Counter, Function Generator

Preparation:

1. Configure the Counter as follows:  
Function: Totalized 1 Measurement
2. Connect the counter input to the 81180A channel 1 output
3. Configure the function generator as follows:  
Waveform: Square  
Run Mode: Triggered
4. Connect the function generator output to the 81180A trigger input
5. Configure the 81180A as follows (both channels):  
Function: Advanced Sequence  
Advance Mode: Once  
SCLK: 4.2 GSa/s  
CH1/2 Outputs: On
6. Using 'BenchLink Waveform Builder Pro', prepare and download the following waveform to both channels:  
Segments 1 to 15: 320 points, 1 cycle square
7. Using 'BenchLink Waveform Builder Pro', build and download five identical sequence tables:  
Step 1: Segments 1, 4, 7, 10 and 13, Repeat = 10, Jump Flag = 0  
Step 2: Segment 2, 5, 8, 11 and 14, Repeat = 10, Jump Flag = 0  
Step 3: Segment 3, 6, 9, 12 and 15, Repeat = 10, Jump Flag = 0
8. Using 'BenchLink Waveform Builder Pro', build and download the following Advanced sequence table:  
Step 1: Sequence 1, Repeat = 10, Jump Flag = 0  
Step 2: Sequence 2, Repeat = 100, Jump Flag = 0  
Step 3: Sequence 3, Repeat = 1,000, Jump Flag = 0  
Step 4: Sequence 4, Repeat = 10,000, Jump Flag = 0  
Step 5: Sequence 5, Repeat = 100,000, Jump Flag = 0

Test Procedure

1. Check channel 1 and then channel 2 sequence operation using *Table 5-54*.

**Table 5-54: Triggered Advanced Sequence - Once Advance Tests**

Remote Enable	Error Limits	Counter Reading		Pass	Fail
		CH1	CH2		
Trigger	3,333,300, ±0				

### 5.19.6 Triggered Advanced Sequence - Stepped Advance Mode

**Triggered Advanced Sequence - Stepped Advance Mode** Equipment: Counter, Function Generator

Preparation:

- Configure the Counter as follows:  
Function: FREQ 1 Measurement
- Connect the counter input to the 81180A channel 1 output
- Configure the function generator as follows:  
Waveform: Square  
Run Mode: Triggered
- Connect the function generator output to the 81180A trigger input
- Configure the 81180A as follows (both channels):  
Function: Advanced Sequence  
Advance Mode: Stepped  
SCLK: 200 MSa/s  
CH1/2 Outputs: On
- Using 'BenchLink Waveform Builder Pro' prepare and download the following waveform to both channels:  
Segments 1, 2 and 3: 320 points, 1 cycle square  
Segments 4, 5 and 6: 512 points, 1 cycle square  
Segments 7, 8 and 9: 1,024 points, 1 cycle square  
Segments 10, 11 and 12: 2,048 points, 1 cycle square  
Segments 13, 14 and 15: 4,096 points, 1 cycle square
- Using 'BenchLink Waveform Builder Pro', build and download the following sequence table:  
Sequence 1:  
Steps 1, 2 and 3: Segments 1, 2 and 3, Repeat = 10, Jump Flag = 0  
Sequence 2:  
Steps 1, 2 and 3: Segments 4, 5 and 6, Repeat = 10, Jump Flag = 0  
Sequence 3:  
Steps 1, 2 and 3: Segments 7, 8 and 9, Repeat = 10, Jump Flag = 0  
Sequence 4:  
Steps 1, 2 and 3: Segments 10, 11 and 12, Repeat = 10, Jump Flag = 0

Sequence 5:

Steps 1, 2 and 3: Segments 13, 14 and 15, Repeat = 10, Jump Flag = 0

8. Using 'BenchLink Waveform Builder Pro', build and download the following Advanced sequence table:

Step 1: Sequence 1, Repeat = 70,000, Jump Flag = 0

Step 2: Sequence 2, Repeat = 50,000, Jump Flag = 0

Step 3: Sequence 3, Repeat = 10,000, Jump Flag = 0

Step 4: Sequence 4, Repeat = 5,000, Jump Flag = 0

Step 5: Sequence 5, Repeat = 5,000, Jump Flag = 0

Test Procedure

1. Check channel 1 and then channel 2 sequence operation using *Table 5-55*.

**Table 5-55: Triggered Sequence - Stepped Advance Tests**

External Trigger	Error Limits	Counter Reading		Pass	Fail
		CH1	CH2		
Trigger 1	625 kHz, $\pm 625$ mHz				
Trigger 2	390.625 kHz, $\pm 391$ mHz				
Trigger 3	195.3125 kHz, $\pm 195$ mHz				
Trigger 4	97.656250 kHz, $\pm 97.7$ mHz				
Trigger 5	48.828125 kHz, $\pm 48.8$ mHz				
Trigger 6	625 kHz, $\pm 625$ mHz				

## 5.20 Remote Interfaces

**Remote Interfaces** This tests the communication with the 81180A using the various interface options. Connecting and setting up the 81180A for operation with the various interface options is described in Chapter 2. Before you proceed with any of the following tests, make sure first that the 81180A is configured to operate with the selected test. GPIB operation requires setting of the GPIB address, LAN operation requires correct setting of the LAN parameters and USB operation requires that the USB port is configured correctly and USB driver installed on the host computer.

## 5.20.1 GPIB Control

### GPIB Control

Equipment: Spectrum Analyzer, BenchLink Waveform Builder Pro

Preparation:

1. Set up the 81180A for GPIB operation and connect the instrument to a host controller
2. Connect 81180A Normal output to the distortion analyzer input.
3. Configure the 81180A as follows:

SCLK: 1,024 GSa/s

Waveform: Arbitrary

Output: On

4. Using 'BenchLink Waveform Builder Pro', prepare and download the following waveform:

Waveform: 1,024 points, Sine wave, 1 cycle

Test Procedure

1. Check the resulting trace on the oscilloscope
2. Perform Sine wave distortion. It should be less than -55 dBc

---

Test Results	Pass		Fail	
--------------	------	--	------	--

## 5.20.2 USB Control

### USB Control

Equipment: Spectrum Analyzer, BenchLink Waveform Builder Pro

Preparation:

1. Set up the 81180A for USB operation and connect the instrument to a host controller
2. Connect 81180A Normal output to the distortion analyzer input.
3. Configure the 81180A as follows:

SCLK: 1,024 GSa/s

Waveform: Arbitrary

Output: On

4. Using 'BenchLink Waveform Builder Pro', prepare and download the following waveform:

Waveform: 1,024 points, Sine wave, 1 cycle

Test Procedure

1. Check the resulting trace on the oscilloscope
2. Perform Sine wave distortion. It should be less than -55 dBc

Test Results	Pass		Fail	
--------------	------	--	------	--

### 5.20.3 LAN Control

#### LAN Control

Equipment: Spectrum Analyzer, BenchLink Waveform Builder Pro

Preparation:

1. Set up the 81180A for LAN operation and connect the instrument to a host controller
2. Connect 81180A Normal output to the distortion analyzer input.
3. Configure the 81180A as follows:

SCLK: 1,024 GSa/s

Waveform: Arbitrary

Output: On

4. Using 'BenchLink Waveform Builder Pro', prepare and download the following waveform:

Waveform: 1,024 points, Sine wave, 1 cycle

Test Procedure

1. Check the resulting trace on the oscilloscope
2. Perform Sine wave distortion. It should be less than -55 dBc

Test Results	Pass		Fail	
--------------	------	--	------	--

## 5.21 Updating 81180A Firmware



Only qualified persons may perform Firmware updates. DO NOT even attempt to perform this operation unless you were trained and certified by Agilent, as you may inflict damage on the instrument. Always verify with the factory that you have the latest firmware file before you start with your update.

Before you update the firmware of your 81180A, check the revision level, which is installed in your instrument. Each firmware update was done for a reason and therefore, if you want to update the firmware for a problem in your system, check the readme file associated with the update to see if an update will solve your problem. The revision level of your firmware can be displayed as shown in *Figure 5-1*. To access this screen, select the TOP menu, then select the Utility soft key and scroll down to the System option. Press Enter and the screen will show the system information. Check both the Software Version and the Version Date as both should match with the latest release.



**Figure 5-1: Software Version Screen**



Firmware updates are performed with the LAN set as the active interface and the 81180A communicating with the PC through the network.

To update the 81180A firmware, you will have to run the '81180A Firmware Update' tool. This update tool can be downloaded from [www.agilent.com/find/81180](http://www.agilent.com/find/81180). Next install the update tool on your PC. To invoke this tool, complete the following steps:

1. Turn power OFF on your 81180A.
2. Click on '81180A Firmware Update' shortcut on the desktop or select *Start – Program Files – Agilent – 81180A Firmware Update*.

The '81180A Firmware Update' window lists Agilent devices found on your subnet. *Figure 5-2* shows an example of this display.

3. Click on the "Use wait message" to select this option as shown in *Figure 5-2*.



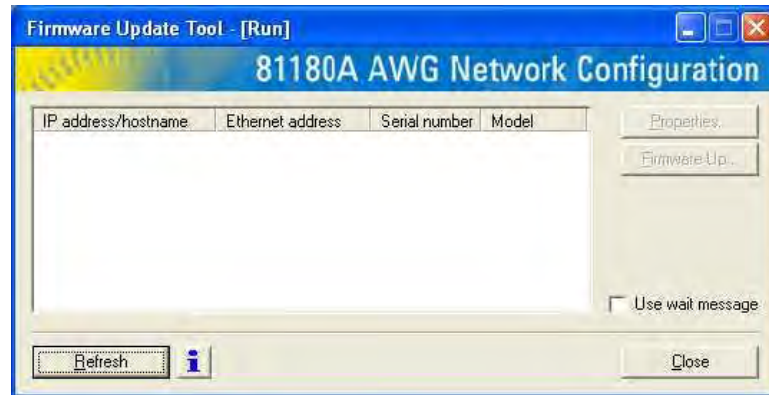

**Figure 5-2: The 81180A AWG Network Configuration Utility**

4. Turn power **ON** on your 81180A and observe that the progress bar, is advancing from left to right. Do not do anything on the 81180A until the progress bar completes its travel to the right end.



If the progress bar is not moving, check the following for possible problems:

1. If you are connecting to a LAN network, make sure your device is connected with standard LAN wire to your wall plug.
2. If you use a direct connection from your PC to the 81180A, your cable should be cross-wired. You can buy this type of cable from any computer store in your area.
3. If your network is using a managed switch, it is possible that it is configured to break the package with a broadcast address and therefore, the only way to use the Network Configuration utility is to connect the instrument directly to the PC with a cross-wired cable.
4. As soon as the progress bar reaches the far right-hand side of the bar, click on the Refresh button. If your device was connected and booted correctly, the device address will appear in the device list, as shown in *Figure 5-3*.

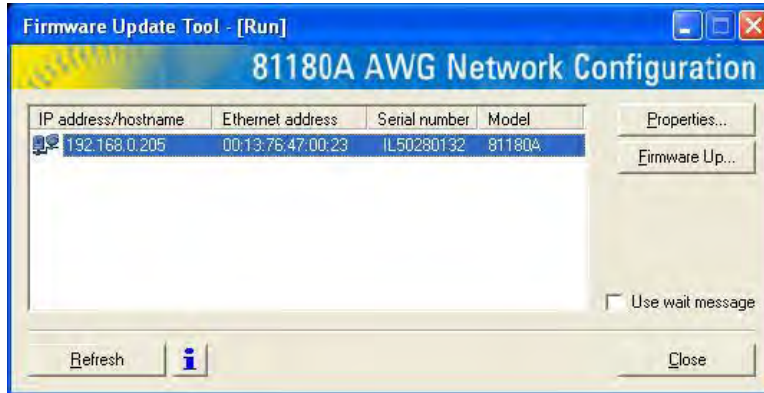

**Figure 5-3: 81180A has been Detected on the LAN Network**



Click Refresh again if you do not see your device in the list of Ethernet devices. If you cannot detect your device after a few attempts, check that you have not lost the connection as described in previous paragraphs.

You can only update instrument(s) that appear in the AWG Network Configuration window.

Point and click on the device you want to update. The selected device will now have a blue background. Click on the **Firmware Up...** button. The firmware Update dialog box as shown in *Figure 5-4* appears.

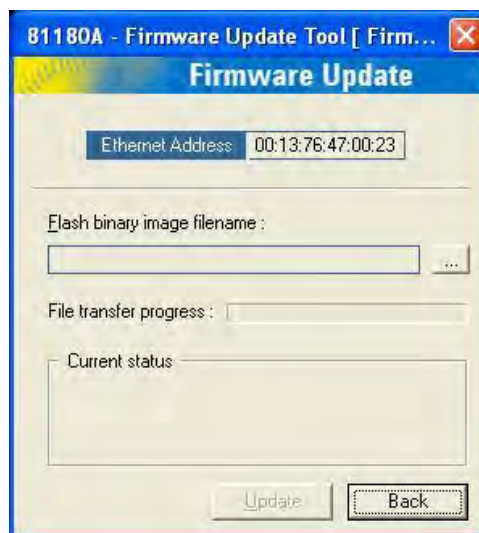

**Figure 5-4: The Firmware Update Dialog Box**

In the AWG Network Configuration [Firmware Update] dialog box click on the  button to browse and locate the upgrade file. After you select the file its complete path will be displayed in the Flash binary image filename field as shown in *Figure 5-5*. Make sure the file in the path agrees with that specified by your supervisor. To complete the update process, click on Update and observe the File Transfer Progress bar. The update will complete with a Firmware Updated Successfully message, as shown in *Figure 5-6*.

Click on Back to close the AWG Network Configuration Firmware Update dialog box and turn off the power to the **81180A**. The next time you power-up the instrument, the device automatically reboots with the new firmware in effect.



**Figure 5-5: Firmware Update Path**



**Figure 5-6: Firmware Update Completed**



Copyright © Agilent Technologies 2011

Fourth edition, December 2011

Printed in Germany



81180-91020



**Agilent Technologies**