

Tektronix[®]
COMMITTED TO EXCELLENCE

015-0611-00



**PLEASE CHECK FOR CHANGE INFORMATION
AT THE REAR OF THIS MANUAL.**

**PROGRAMMABLE
PULSE HEAD
015-0611-00**

**Tektronix, Inc.
P.O. Box 500
Beaverton, OR 97077**

070-7893-00
Product Group 75

Serial Number _____

First Printing JAN 1991
Revised AUG 1991

TEK INTER-OFFICE COMMUNICATION

TO John Martin 94-540 DATE June 25, 1991
FROM Frank Gray, 50-PAT
SUBJECT GIDEP permit request

In response to the request to grant permission to the Government Industry Exchange Program (GIDEP) to reproduce Tektronix operator, service and instruction manuals, Tektronix, Inc. hereby grants such permission for distribution of such documents to any GIDEP user that is a full participant in the Metrology Data Interchange Data Base of GIDEP provided that all copies of the original work include the entire copyright notice and ownership statement exactly as it appears in the original, together with the Legend "Reproduced with permission."

This permission has been approved by the Intellectual Property Committee of Tektronix, and a copy of this memo may be provided to GIDEP to provide the requested permission.

Francis I. Gray
Group Patent Counsel

imp

Copyright © 1991 Tektronix, Inc. All rights reserved. Contents of this publication may not be reproduced in any form without the written permission of Tektronix, Inc.

Products of Tektronix, Inc. and its subsidiaries are covered by U.S. and foreign patents and /or pending patents.

TEKTRONIX, TEK, SCOPE-MOBILE and  are registered trademarks of Tektronix, Inc. TELEQUIPMENT is a registered trademark of Tektronix U.K. Limited.

Printed in U.S.A. Specification and price change privileges are reserved.

INSTRUMENT SERIAL NUMBERS

Each instrument manufactured by Tektronix has a serial number on a panel insert, tag, or stamped on the chassis. The letter at the beginning of the serial number designates the country of manufacture. The last five digits of the serial number are assigned sequentially and are unique to each instrument. Those manufactured in the United States have six unique digits. The country of manufacture is identified as follows:

B010000	Tektronix, Inc., Beaverton, Oregon, USA
J300000	Sony/Tektronix, Japan
H700000	Tektronix Holland, NV, Heerenveen, The Netherlands

Instruments manufactured for Tektronix by external vendors outside the United States are assigned a two-digit alpha code to identify the country of manufacture (e.g., JP for Japan, HK for Hong Kong, IL for Israel, etc.).

TABLE OF CONTENTS

	Page		Page
LIST OF ILLUSTRATIONS	ii	Section 5 MAINTENANCE	5-1
LIST OF TABLES	ii	Recalibration	5-1
OPERATORS SAFETY SUMMARY	iii	Disassembly and Reassembly	5-1
SERVICE SAFETY SUMMARY	iv	Bottom Cover Removal and	
		Replacement	5-1
Section 1 SPECIFICATION	1-1	Top Cover Removal and Replacement ..	5-2
Introduction	1-1	Hypcon Connector	5-2
Accessories	1-1	Disassembly and Removal	5-2
Performance Conditions	1-1	Reassembly and Replacement	5-4
Electrical Characteristics	1-1	Board Removal and Replacement	5-4
Environmental Characteristics	1-2	Cable Removal and Replacement	5-4
Physical Characteristics	1-2	Log Cell Removal and Replacement	5-4
		Cleaning Instructions	5-5
Section 2 OPERATING INSTRUCTIONS	2-1	Exterior	5-5
Introduction	2-1	Interior	5-5
Connecting to the CG 5010/CG 5011	2-1	Obtaining Replacement Parts	5-5
Controls and Connectors	2-1	Ordering Parts	5-5
General Operating Information	2-1	Static-Sensitive Components	5-5
Programming Commands Via GPIB	2-2	Test Equipment	5-6
Repackaging Information	2-3		
		Section 6 OPTIONS	6-1
		Section 7 REPLACEABLE ELECTRICAL PARTS	
		Section 8 DIAGRAMS AND ILLUSTRATIONS	
		Schematic Diagrams	
		Parts Location Grids	
		Section 9 REPLACEABLE MECHANICAL PARTS	
		Exploded View	
		Accessories	
		CHANGE INFORMATION	
Section 3 THEORY OF OPERATION	3-1		
Introduction	3-1		
Relay Switching Circuit	3-2		
Fast Edge Driving Circuit	3-2		
Positive Fast Edge Generator	3-2		
Negative Fast Edge Generator	3-4		
Straight-Through (Direct) Mode	3-4		
Section 4 CALIBRATION	4-1		
Performance Check	4-1		
Introduction	4-1		
Calibration Interval	4-1		
Services Available	4-1		
Test Equipment Required	4-1		
Performance Check Procedure	4-2		
Adjustment Procedure	4-5		
Introduction	4-5		
Test Equipment Required	4-5		
Preparation	4-5		

WARNING

THE FOLLOWING SERVICING INSTRUCTIONS ARE FOR USE BY QUALIFIED PERSONNEL ONLY. TO AVOID PERSONAL INJURY DO NOT PERFORM ANY SERVICING OTHER THAN THAT CONTAINED IN OPERATING INSTRUCTIONS UNLESS YOU ARE QUALIFIED TO DO SO.

LIST OF ILLUSTRATIONS

Fig. No.	Page	Fig. No.	Page
Programmable Pulse Head, 015-0611-00	v		
2-1 Pulse Head Connector	2-1	3-8 From NEGATIVE FAST EDGE Mode To Direct Mode	3-6
3-1 Pulse Head Block Diagram	3-1	4-1 Measurement of step 2 risetime	4-3
3-2 From NEGATIVE To POSITIVE While In FAST EDGE Mode	3-2	4-2 Measurement of step 3 upper peak of aberration	4-4
3-3 From POSITIVE To NEGATIVE While in FAST EDGE Mode	3-3	4-3 Measurement of step 3 peak-to-peak aberration of adjacent peaks.	4-4
3-4 From Direct Mode To POSITIVE FAST EDGE Mode	3-3	5-1 Maintenance Diagram (Exploded View).....	5-1
3-5 From Direct Mode to NEGATIVE FAST EDGE Mode	3-4	5-2 Hypcon Connector (Exploded View)	5-3
3-6 Polarity And Output Relay Switching	3-5	8-1 Edge Driver Board (A20) (Parts Location)	
3-7 From POSITIVE FAST EDGE Mode To Direct Mode	3-6	8-2 Fast Edge Board (A22) (Parts Location)	
		8-3 Fast Edge Board (A22) (Adjust Location)	

LIST OF TABLES

Table No.	Page	Table No.	Page
1-1 ELECTRICAL CHARACTERISTICS	1-1	4-1 LIST OF TEST EQUIPMENT REQUIREMENTS	4-1
1-2 ENVIRONMENTAL CHARACTERISTICS	1-2	5-1 RELATIVE SUSCEPTIBILITY TO STATIC DISCHARGE DAMAGE	5-6
1-3 PHYSICAL CHARACTERISTICS	1-2		
2-1 CG 5010/CG5011 SETTING COMMANDS	2-2		

OPERATORS SAFETY SUMMARY

The general safety information in this part of the summary is for both operating and servicing personnel. Specific warnings and cautions will be found throughout the manual where they apply, but may not appear in this summary.

TERMS

In This Manual

CAUTION statements identify conditions or practices that could result in damage to the equipment or other property.

WARNING statements identify conditions or practices that could result in personal injury or loss of life.

As Marked on Equipment

CAUTION indicates a personal injury hazard not immediately accessible as one reads the marking, or a hazard to property including the equipment itself.

DANGER indicates a personal injury hazard immediately accessible as one reads the marking.

SYMBOLS

In This Manual

 This symbol indicates where applicable cautionary or other information is to be found.

As Marked on Equipment

 **DANGER** – High voltage.

 Protective ground (earth) terminal.

 **ATTENTION** – refer to manual.

Danger Arising From Loss of Ground

Upon loss of the protective-ground connection, all accessible conductive parts (including knobs and controls that may appear to be insulating) can render an electric shock.

Use the Proper Power Cord

Use only the connector specified for your product.

Refer connector changes to qualified service personnel.

Do Not Operate in Explosive Atmospheres

To avoid explosion, do not operate this product in an explosive atmosphere unless it has been specifically certified for such operation.

Do Not Remove Covers or Panels

To avoid personal injury, do not remove the product covers or panels. Do not operate the product without the covers and panels properly installed.

SERVICE SAFETY SUMMARY

FOR QUALIFIED SERVICE PERSONNEL ONLY

Refer also to the preceding Operators Safety Summary.

Do Not Service Alone

Do not perform internal service or adjustment of this product unless another person capable of rendering first aid and resuscitation is present.

Use Care When Servicing With Power On

To avoid personal injury, do not touch exposed connections and components while power is on.

Disconnect power before removing protective panels, soldering, or replacing components.

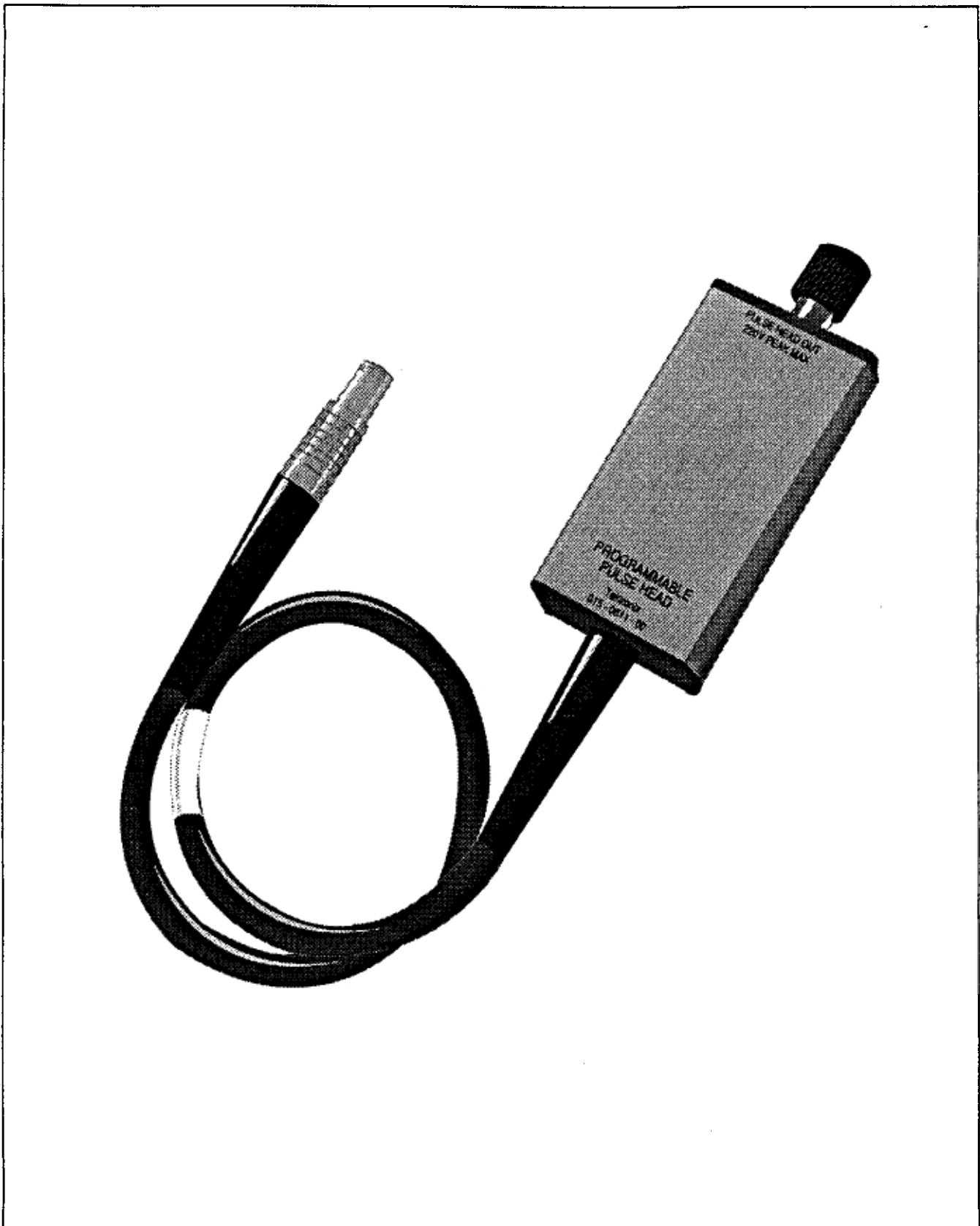

Programmable Pulse Head 015-0611-00

SPECIFICATION

Introduction

The Pulse Head is an accessory to the CG 5010/CG 5011 programmable Calibration Generator. It connects to the main output of the CG 5010/CG 5011 and is programmed and stimulated by signals from the CG 5010/CG 5011. This accessory generates 1 V square waves with a well defined leading edge. This edge is used to verify and calibrate transient response in wide-band oscilloscopes.

Accessories

This instruction manual is the only standard accessory.

Performance Conditions

The electrical characteristics are valid only if the Pulse Head has been calibrated at an ambient temperature between +20°C and +30°C and is operating at an ambient temperature between 0°C and +50°C, unless otherwise noted.

Items listed in the Performance Requirements column of the Electrical Characteristics are verified by completing the Performance Check in the Calibration section of this manual.

Items listed in the Supplemental Information column are not verified in this manual.

Table 1-1
ELECTRICAL CHARACTERISTICS

Characteristics	Performance Requirements	Supplemental Information
Fast Edge Pulse		
Amplitude	1.1 V peak, $\pm 5\%$.	Required Input Signals: V Control Pin = ± 9.6 V, $\pm 1\%$. V Coax = ± 5 V, $\pm 1\%$.
Variable Range	$\pm 10\%$.	
Polarity	Positive rising from ground to +1 V or negative falling from ground to -1 V.	In the straight-through mode, the pulse will output any signal routed through the CG 5010/CG 5011 OUTPUT connector.
Risetime	≤ 150 ps.	Driving waveform T, < 10 ns. Triggered on edge going to ground.
Leading Edge Aberrations	$\pm 3\%$ of pulse amplitude; not to exceed 4%, p-p for adjacent peaks.	Valid from 0 to 50 ns after step. Verified with SD-22 sampling head.
Long Term Flatness		$\pm 1\%$, after 50 ns.
Frequency	100 Hz to 100 kHz in decade steps.	
Source Resistance		50 Ω , $\pm 2\%$.
Control Pin Signals		
Programming		± 12 V, 150 mA maximum.
Operating		± 10 V, 60 mA maximum.
Coax Signals		
Programming		± 5 V 30 mA maximum (dc).
Operating		± 5 V, 30 mA maximum (square wave).
Maximum Power Requirements		
Programming		< 2 W.
Operating		< 1 W.
Straight-through mode		< 0.05 W.

**Table 1-2
ENVIRONMENTAL CHARACTERISTICS**

Characteristics	Description	
Temperature	Meets MIL-T-28800B, class 5.	
Operating	0°C to +50°C.	
Non-operating	-55°C to +75°C.	
Humidity	90-95% RH for 5 days to 50°C.	Exceeds MIL-T-28800B, class 5 .
Altitude	Exceeds MIL-T-28800B, class 3.	
Operating	4.6 km (15,000 feet).	
Non-operating	15 km (50,000 feet).	
Vibration	0.64 mm (0.0252") 10 Hz to 55 Hz, 75 minutes.	Meets or exceeds MIL-T-28800B, class 3.
Shock	50 g's (1/2 sine), 11 ms, 18 shocks.	Meets or exceeds MIL-T-28800B, class 3.
Bench Handling	45° or 4" equilibrium, whichever occurs first.	Meets MIL-T-28800B, class 3.
EMI Compatibility	Meets MIL-T-28800B, class 3 MIL-STD-461A when performed in accordance with MIL-STD-462 with following exceptions: Radiated emissions, tested to 30 dB above specification from dc to 700 MHz.	
Conducted Emissions		
Conducted Susceptibility		
Radiated Emissions		
Radiated Susceptibility		
Electrical Discharge	20 kV maximum.	Charge applied to each protruding area of the product under test except the output terminals.
Transportation	Qualified under National Safe Transit Association Preshipment Test Procedures 1A-B-1 and 1A-B-2.	
Vibration	25 mm (1") at 270 rpm for 1 hour.	
Package Drop	10 drops from 91 cm (3 ft).	
Cables		
Flex Life	10,000 cycles at 120° flex with 0.68 kg (1.5 lb) weight.	
Pull Test	15.88 kg (35 lbs) axial pull at 1 minute duration.	

**Table 1-3
PHYSICAL CHARACTERISTICS**

Characteristics	Description
Finish	Light and dark gray painted metal.
Overall Dimensions	196.9 mm (7.75") L x 53.4 mm (2.102") W x 38.1 mm (1.5") H.
Net Weight	0.27 kg (0.6 lb).

OPERATING INSTRUCTIONS

Introduction

The Pulse Head is an accessory designed to operate with the CG 5010/CG 5011 Programmable Calibration Generator and is calibrated and ready to use when received.

The attached cable from the Pulse Head contains signal as well as power lines and connects directly to the CG 5010/CG 5011 front panel OUTPUT connector. Power for the head is taken from the CG 5010/CG 5011 through this connector.

The Pulse Head is programmed and stimulated by signals from the CG 5010/CG 5011. The head generates a square-wave whose leading edge is used to verify and calibrate transient responses in other instruments.

Connecting to CG 5010/CG 5011

CAUTION

Use care when connecting the Pulse Head plug to the CG 5010/CG 5011 to avoid pin misalignment and possible connector damage.

Observe the positioning dot on the Pulse Head plug and align this dot with the positioning dot on the outside ring of the

CG 5010/CG 5011 OUTPUT connector. Insert the plug into this connector slowly.

Controls and Connectors

OUTPUT Connector-Output for CG 5010/CG 5011 amplitude mode voltage, time signals, or current signals (direct mode operation). Output for Pulse Head generated positive-going or negative-going fast rise pulses (pulse mode operation).

General Operating Information

With the appropriate CG 5010/CG 5011 settings and proper triggering of the oscilloscope, a fast edge pulse will appear on the crt screen. This pulse will indicate that the Pulse Head is functioning properly.

Attach the Pulse Head OUTPUT connector to the oscilloscope under calibration. The oscilloscope being calibrated should be checked for time base accuracy and linearity.

After warm-up time, press to light the CG 5010/CG 5011 OUTPUT ON pushbutton and the FAST EDGE pushbutton. Select either the \wedge (positive) or ∇ (negative) EDGE POLARITY pushbuttons on the CG 5010/CG 5011.

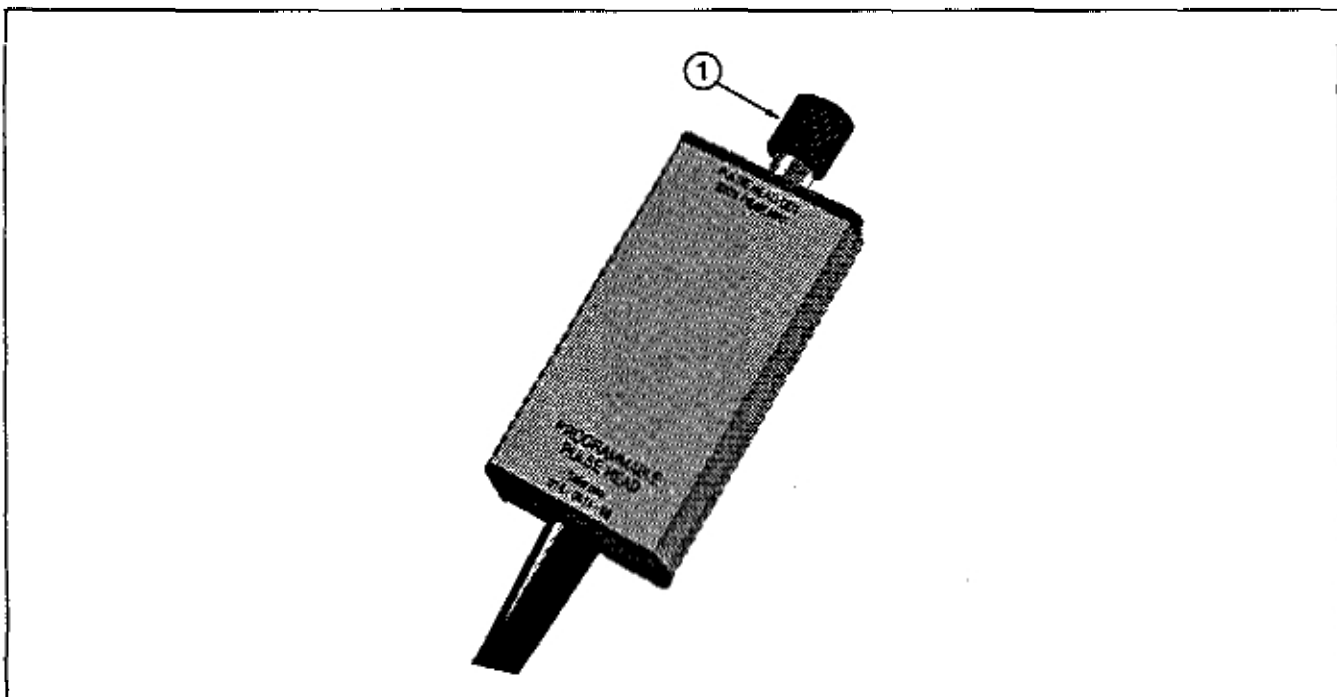

Fig. 2-1. Pulse Head connector.

Operating Instructions – Pulse Head 015-0611-00

With the appropriate plug-in settings and proper triggering of the Oscilloscope a fast edge pulse will appear on the crt screen. This pulse will indicate that the Pulse Head is functioning properly.

Programming Commands Via GPIB

The Pulse Head can be programmed from the CG 5010/CG 5011 via commands received from the GPIB. The commands (Header and Argument) and descriptions are given in Table 2-1.

Table 2-1
CG 5010/CG 5011 SETTING COMMANDS

Header	Argument	Description
MODE	FE or FASTEDGE	Sets instrument to FAST EDGE mode.
POS		Sets positive EDGE polarity.
NEG		Sets negative EDGE polarity.
TRIG	ON	Turns TRIGGER OUTPUT on.
	OFF	Turns TRIGGER OUTPUT off.
	NORM	Sets trigger rate same as output signal rate
	X.1	Turns on TRIGGER OUTPUT and sets trigger rate to one-tenth output signal rate.
	X.01	Turns on TRIGGER OUTPUT and sets trigger rate to one-hundredth output signal rate.
FXD		Sets instrument to 0.0% error with error display off.
VAR		Sets instrument to display device under test percent error readout.
PCT	<nr 2>	Sets device under test percent readout.
INC		Adds 0.1 to present device under test error readout for HIGH and FAST indications or subtracts 0.1 for LOW and SLOW indications.
DEC		Subtracts 0.1 from present percent error readout for HIGH and FAST indications or adds 0.1 for LOW and SLOW indications.
FREQ	<nr 3>	Sets chop frequency from 100 Hz to 100 kHz.
TRIG	ON	Turns TRIGGER OUTPUT on.
	OFF	Turns TRIGGER OUTPUT OFF.
	NORM	Sets trigger rate same as output signal rate.
	X.1	Turns on TRIGGER OUTPUT and sets trigger rate to one-tenth output signal rate.
	X.01	Turns on TRIGGER OUTPUT and sets trigger rate to one-hundredth output signal rate.
OUT	ON	Sets main OUTPUT off.
	OFF	Sets main OUTPUT off.

NOTE

Refer to the CG 5010/CG 5011 instruction manual Programming section for more detailed information.

Operating Instructions – Pulse Head 015-0611-00

Repackaging Information

If shipping this instrument to a Tektronix Service Center for service or repair, attach a tag showing owner (with address) and the name of an individual to contact. Include the complete instrument serial number and a description of the service required.

Save and reuse the package in which the instrument was shipped. If the original packaging is unfit for use or not available, repackage the instrument as follows:

1. Obtain a corrugated carton having inside dimensions of no less than six inches more than the instrument dimensions; this will allow for cushioning. Use a carton having a test strength of at least 200 pounds.
2. Surround the instrument with protective polyethylene sheeting.
3. Cushion the instrument on all sides by tightly packing dunnage or urethane foam between carton and instrument, allowing three inches on all sides.
4. Seal carton with shipping tape or industrial staples.

WARNING

THE FOLLOWING SERVICING INSTRUCTIONS ARE FOR USE BY QUALIFIED PERSONNEL ONLY. TO AVOID PERSONAL INJURY, DO NOT PERFORM ANY SERVICING OTHER THAN THAT CONTAINED IN OPERATING INSTRUCTIONS UNLESS YOU ARE QUALIFIED TO DO SO.



THEORY OF OPERATION

Introduction

Power, control logic, and signal input to the Pulse Head is obtained from the CG 5010/CG 5011 OUTPUT connector, through two leads and a coaxial cable.

After connecting the Pulse Head, the CG 5010/CG 5011 Head Sense circuit senses the particular head connected. When a Pulse Head is connected, the CG 5010/CG 5011 connector control pin has, momentarily, approximately +3 Vdc. When this voltage is sensed by the CG 5010/CG 5011 Head Sense circuit, the relays are energized for the straight-through mode.

The Pulse Head circuitry is composed of three functional blocks: positive fast-edge generator, negative fast-edge generator and the relay drivers. See Fig. 3-1.

Two different signals are required to drive the Pulse Head circuits:

1. A variable 10 Vdc ($\pm 10\%$) to supply power to the relay drivers and fast edge generators. After programming, this voltage also determines the amplitude of the 1 V fast edge output.

2. A squarewave ± 5 V to trigger the drive circuitry and to program the relays.

In the straight-through (direct) mode the output relay, K1010, is set to allow voltage, timing, or current signals generated in the CG 5010/CG 5011 to pass directly to the Pulse Head OUTPUT connector. With relay K1010 switched to the FAST EDGE mode position, either positive-going or negative-going fast rise pulses (generated by Pulse Head circuitry) are passed to the OUTPUT connector. See waveforms in Fig. 3-2 and Fig. 3-3 for output pulses. Signals controlling this action come from the CG 5010/CG 5011 during the first 35 ms after power on, or a mode switching, or polarity change occurs (see waveforms in Fig. 3-4 and Fig. 3-5). Switching is arranged so that only one relay (log cell) is switched at a time. The 35 ms settling delay prevents both relays switching at the same time.

NOTE

The waveforms shown are idealized and only approximate the display readout for the given signal conditions.

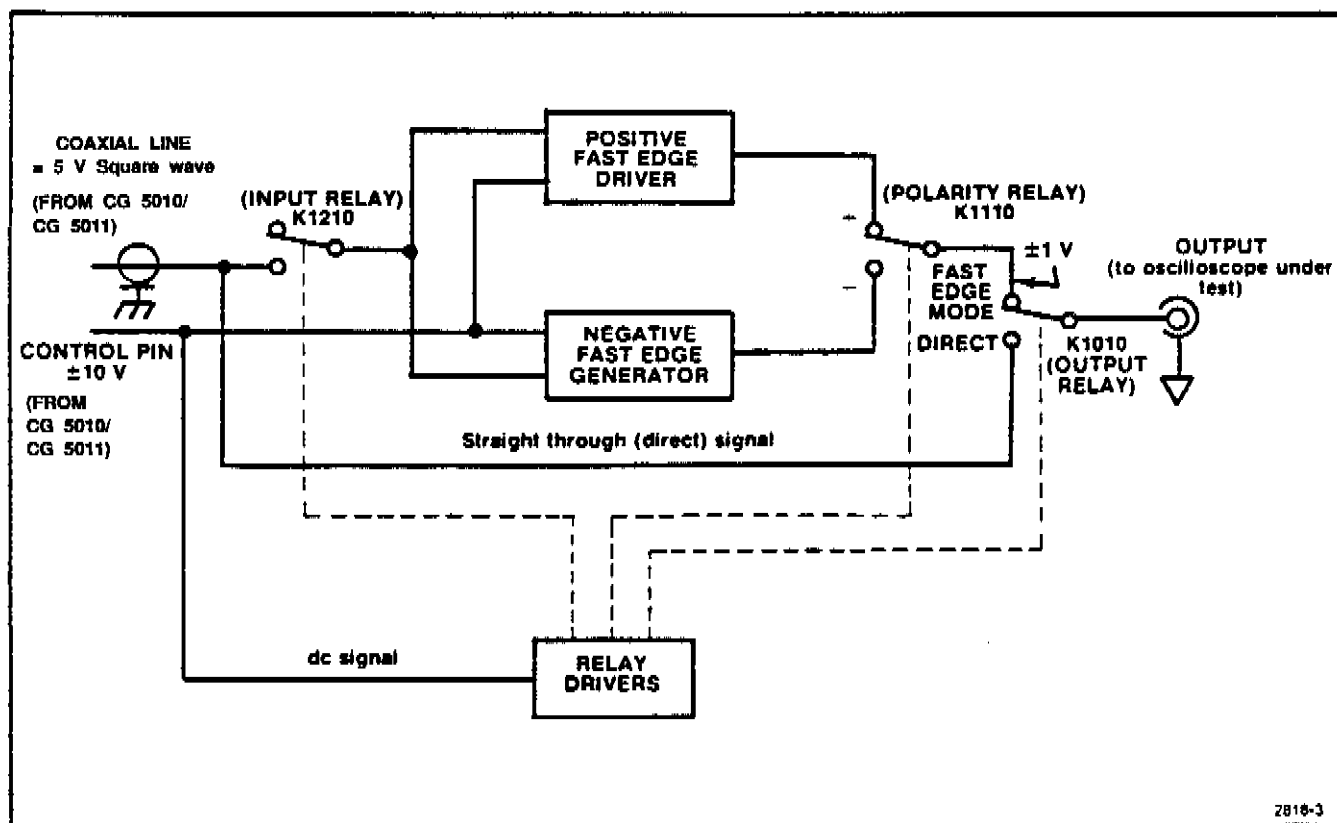

Fig. 3-1. Pulse Head block diagram.

Relay Switching Circuit

The input relay, K1210, closes whenever the control line goes to + or -12 V. The output relay, K1010, and polarity relay, K1110, are dual coil latching switches. A 10 ms pulse is required to set or reset them. The CG 5010/CG 5011 generates all programming signals for the relays. Relay K1010 is pulsed when the control pin and the coaxial line both have the same polarity. The ± 5 V is dc coupled to the bases of transistors Q1211 and Q1213. Relay K1110 is driven when the 10 V changes polarity. The signal is ac coupled through C1103 (located on the Edge Driver board) to the bases of transistors Q1200 and Q1203. This signal, depending on polarity, causes a current pulse in the collector of either Q1200 or Q1203. With 10 V on the control pin, the input relay K1210 is closed connecting the coax center conductor to the edge driver circuits.

After entering the FAST EDGE mode, the CG5010/CG 5011 programs the control pin positive (+12 V). After 35 ms settling delay, the coaxial signal cable is programmed positive for another 35 ms. As the control pin draws current through R1202, (located on the Edge Driver board) K1210 closes. A positive voltage (+10 V) is applied through CR1100 to the collector of Q1200. This sets K1110 (see Fig. 3-6). Positive drive is also applied to Q1211 (also through CR1100), which

sets K1010. A few milliseconds later, the CG 5010/CG 5011 applies dc voltage and signal voltage as required for the pulse polarity selected by the EDGE POLARITY pushbuttons on the CG 5010/CG 5011.

When the positive EDGE POLARITY pushbutton on the CG 5010/CG 5011 is pressed, the operation for the Pulse Head circuit requires the control pin to remain at +10 V and the coaxial line to supply a square wave that switches between ground and -5 V through R1117 (see Fig. 3-6). With these two lines carrying opposite polarity voltages, Q1211 remains off and no further switching of K1010 occurs. Q1200 is off. The time constant set by R1200 and C1103 (located on the Edge Driver board) in the base of Q1200 determines the length of time Q1200 is on. The +10 V is now applied through diode CR1100 as supply voltage for the positive fast-edge generator circuit. The CG 5010/CG 5011 has now changed the signal on the coaxial line from +5 V to a negative square wave (between ground and -5 V). The repetition rate is determined by the lighted FREQUENCY pushbutton on the CG 5010/CG 5011.

Fast Edge Driving Circuits

Positive Fast Edge Generator. This generator is composed of transistors Q1001, Q1202, Q1101, Q1000, and associated circuitry.

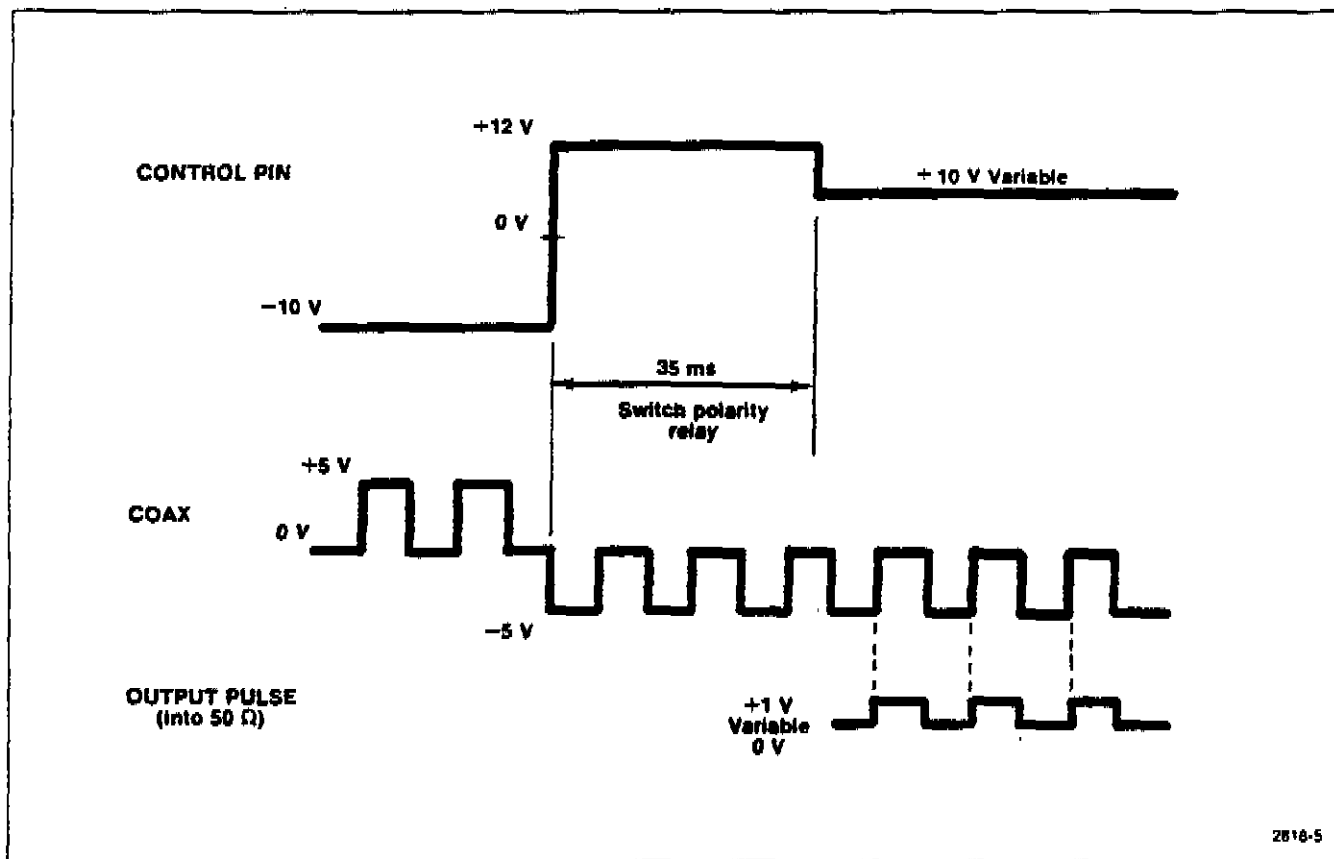

Fig. 3-2. From NEGATIVE to POSITIVE while in FAST EDGE mode.

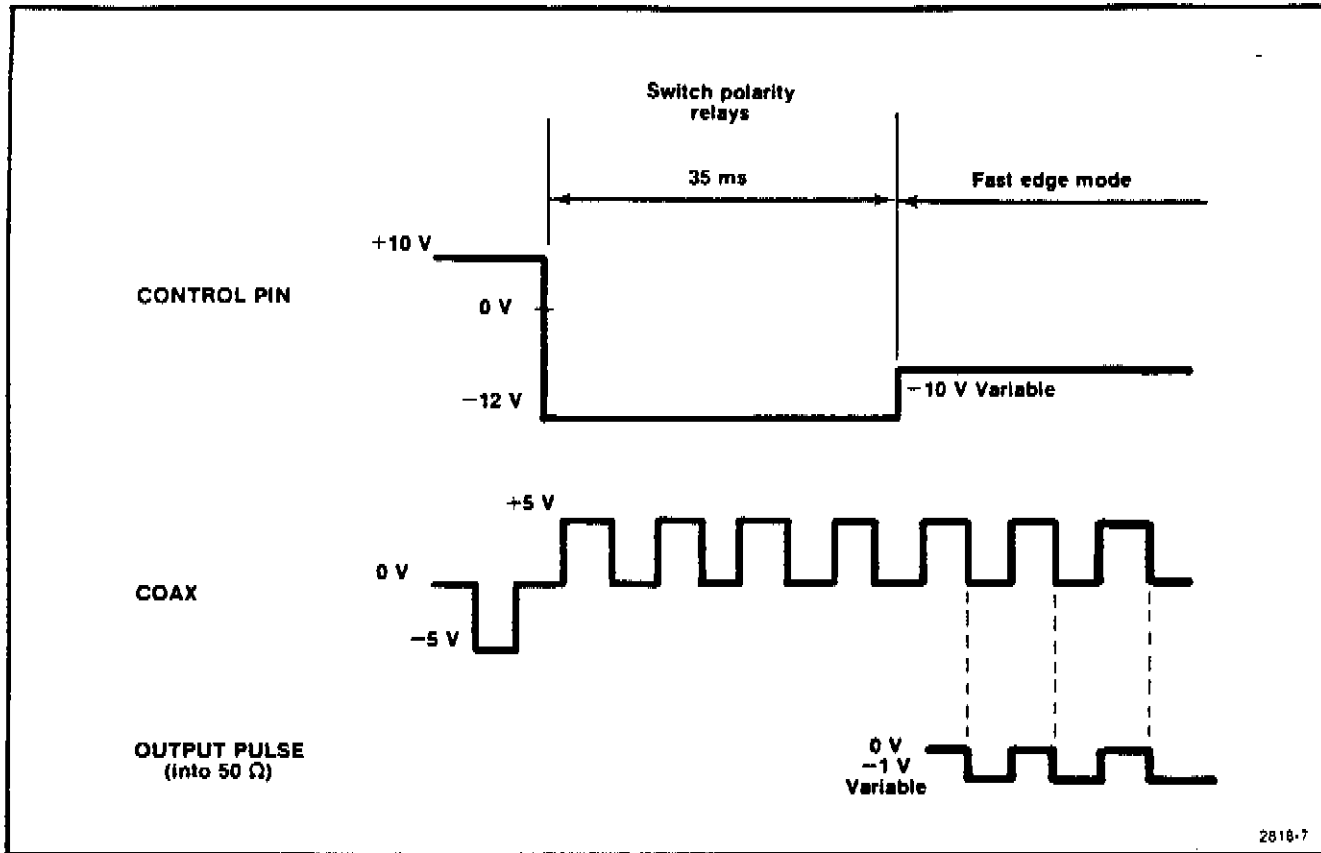

Fig. 3-3. From POSITIVE to NEGATIVE while in FAST EDGE mode.

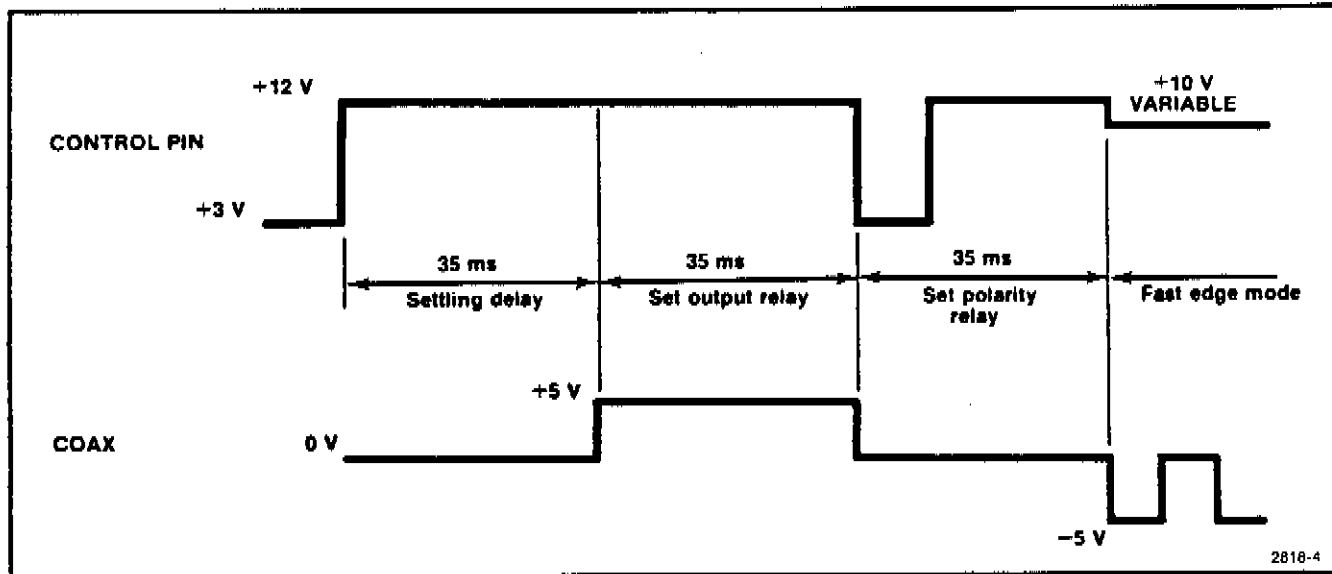

Fig. 3-4. From direct mode to POSITIVE FAST EDGE mode.

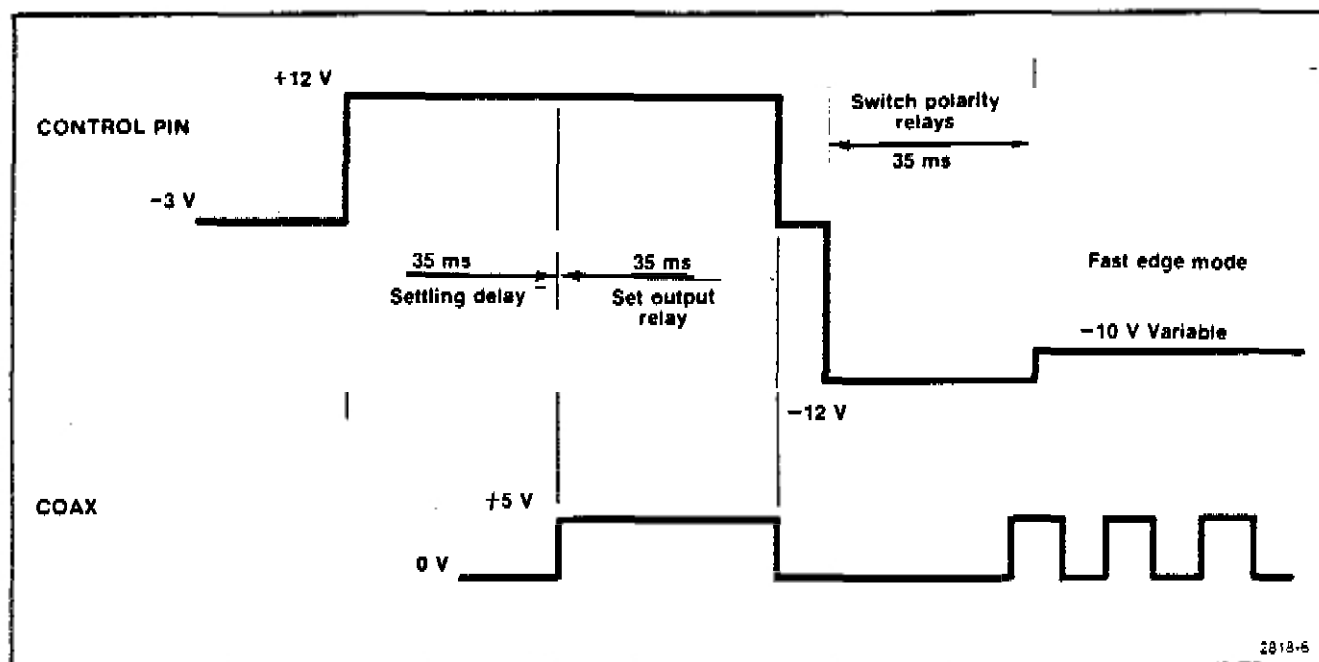

Fig. 3-5. From direct mode to NEGATIVE FAST EDGE mode.

When the signal on the coaxial line is -5 V , Q1202 and Q1001 are turned off. Diode CR1000 conducts. When Q1001 is not conducting, Q1101 is turned on to maintain a constant current through diode CR1100 and a constant voltage on Q1001 emitter. This improves the waveform long term flatness at low repetition rates. This action connects Q1000 (current source) to -5 V to forward bias, a snap-off diode located in the hybrid pulse shaper circuit, U1112. During forward conduction, the snap-off diode stores current carriers. When the coaxial line driving waveform rises toward ground, Q1000 turns off and Q1202 turns on. This causes Q1001 to turn on. The positive voltage now applied to the shaper circuit in the Hybrid Pulser causes the current to reverse. The snap-off diode momentarily acts like a battery (until it runs out of stored carriers). When the diode stops conducting, the voltage across the diode snaps positive. This positive excursion develops a fast step at the OUTPUT connector. The output must be terminated in $50\ \Omega$ to obtain the proper waveshape.

As the coaxial line driving signal goes to -5 V , CR1000 conducts causing Q1000 to turn on. The snap-off diode in the hybrid shaper circuit is again forward biased and the cycle repeats.

The 5.1 V Zener diode, VR1205 acts as a voltage stabilizer in the base circuit of Q1202 to prevent changes in time delay with amplitude. To minimize jitter, the bias on VR1205 is chosen so that triggering occurs at the steepest point of the 5 V driving waveform.

Negative Fast Edge Generator. This generator is composed of transistors Q1212, Q1111, Q1012, Q1011, and associated circuitry.

The negative fast edge generator operation is similar to the positive fast edge operation. Refer to the Positive Fast Edge Generator circuit description.

Straight-Through (Direct) Mode. When the CG 5010/CG 5011 is switched out of the fast edge mode, both the control pin and coaxial lines go negative. See waveforms in Fig. 3-7 and Fig. 3-8. This applies a negative voltage and negative base drive to Q1213 which switches K1010 to the reset (direct mode) position (see Fig. 3-6). Approximately 10 ms later, the CG 5010/CG 5011 shifts the control line to near 0 V which opens the input relay, K1210

The CG 5010/CG 5011 output signal is now connected directly to the OUTPUT connector on the Pulse Head.

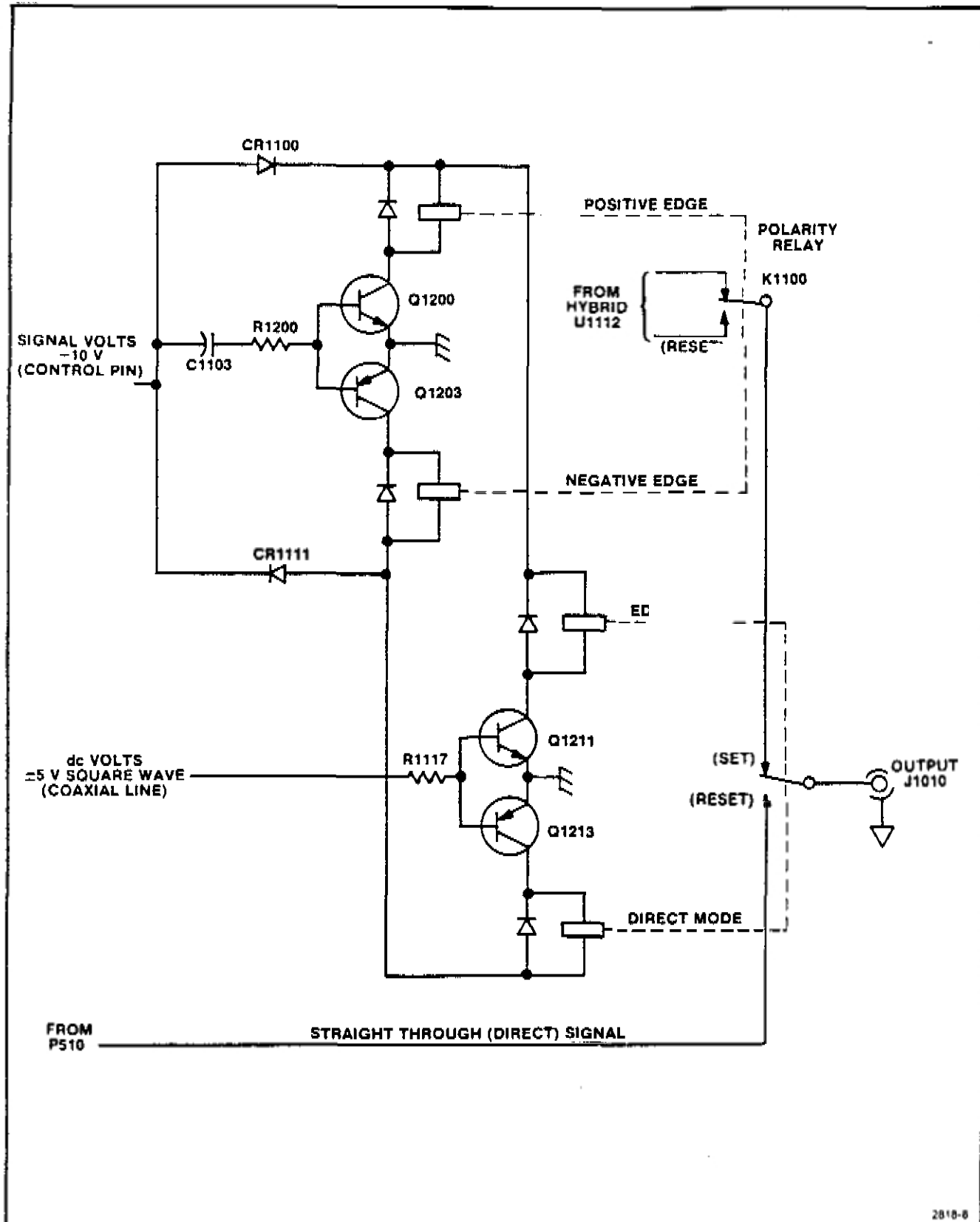

Fig. 3-6. Polarity and output relay switching.

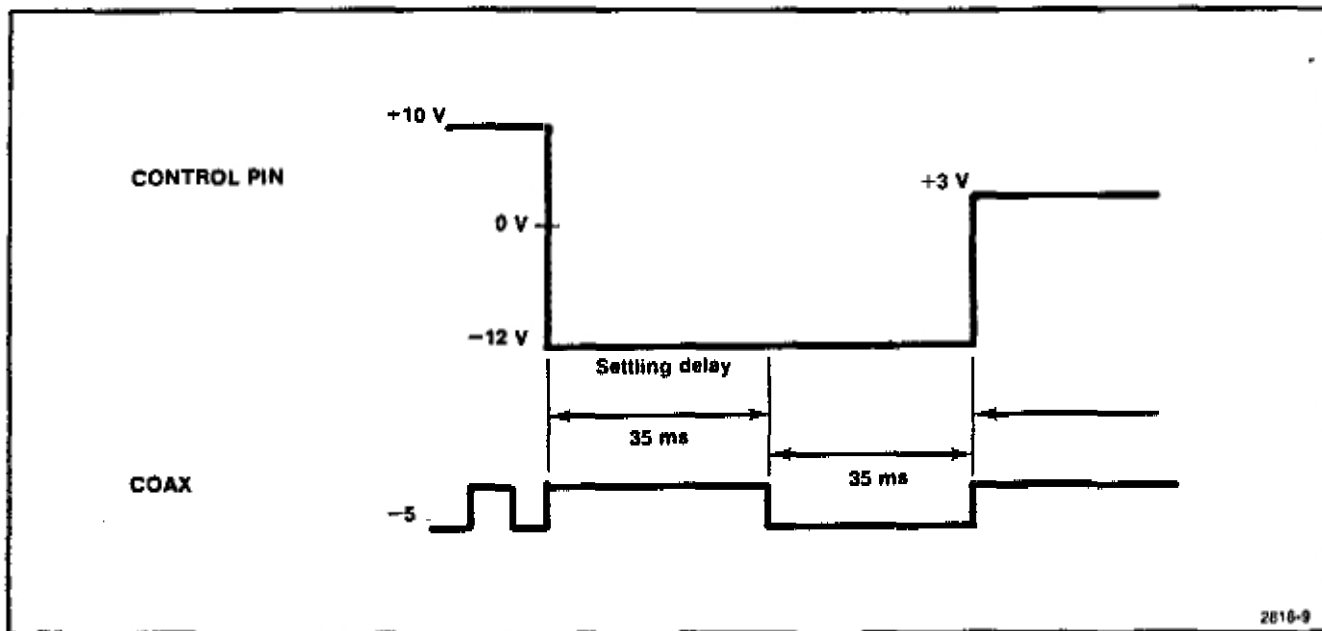

Fig. 3-7. From POSITIVE FAST EDGE mode to direct mode.

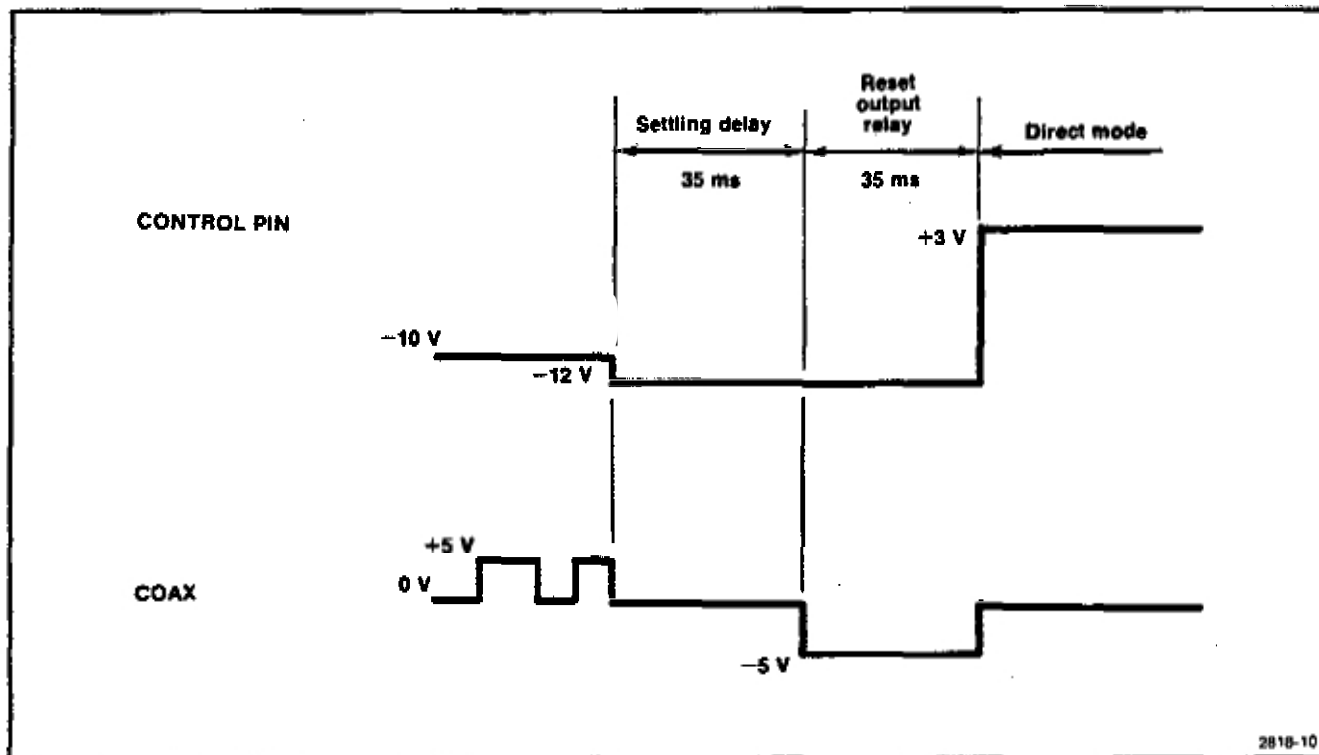

Fig. 3-8. From NEGATIVE FAST EDGE mode to direct mode.

CALIBRATION

PERFORMANCE CHECK

Introduction

This procedure checks the electrical performance requirements as listed in the Specification section in this manual. Perform the Adjustment procedure if the Pulse Head fails to meet these checks. In some cases, recalibration may not correct the discrepancy; circuit troubleshooting is then indicated.

Calibration Interval

To ensure instrument accuracy, check the calibration every 1000 hours of operation or at a minimum of every six months if used infrequently.

Services Available

Tektronix, Inc. provides complete instrument repair and adjustment at local field service centers and at the factory service center. Contact your local Tektronix field office or representative for further information.

Test Equipment Required

The following test equipment or equivalent is suggested to perform the Performance Check and Adjustment procedure (refer to Table 4-1).

Table 4-1
LIST OF TEST EQUIPMENT REQUIREMENTS

Description	Minimum Specifications	Applications	Example
Power Module	GPIB Compatible	All tests	TEKTRONIX TM 5006A
Programmable Calibration Generator, CG 5010/CG 5011		All tests	TEKTRONIX CG 5010/CG 5011
Digital Sampling Oscilloscope	Must accept sampling heads	All tests	TEKTRONIX 11801, 11802, CSA 803
Sampling Head	Risetime ≤ 17.5 ps	All tests	TEKTRONIX SD-22
2X Attenuator BNC connectors	50 Ω , (6 dB)	All tests	Tektronix Part No. 011-0069-02
50 Ω BNC to 3.5 mm (SMA) adapter (2 req)		All tests	Tektronix Part No. 015-1018-00
Insulated adjustment tool		Adjustment Procedure	Tektronix Part No. 003-0675-00
Coaxial Cable	BNC connectors	All tests	Tektronix Part No. 012-0057-01

PERFORMANCE CHECK PROCEDURE

Equipment Setup:

Connect Pulse Head to CG 5010/CG 5011 and to sampling head with BNC to SMA adapter. Connect CG 5010/CG 5011 TRIGGER OUTPUT to 11801 Trigger Output with a X2 attenuator.

Preliminary control settings:

Set CG 5010/CG 5011 controls:

AMPLITUDE MODE	FAST EDGE
EDGE POLARITY	(POSITIVE) 
VARIABLE	OFF
FREQUENCY	100 kHz
OUTPUT	ON
TRIGGER OUTPUT	NORM,ON

Depress and hold the FAST EDGE pushbutton until the CG 5010/CG 5011 display shows "dL". This places the Pulse Head in delayed mode.

Set 11801 controls:

- Select the Utility main menu by pressing the Utility pushbutton.
- Touch the Initialize block on the main menu.
- Select the Sampling Head channel that is connected to the Pulse Head by pressing the Select Channel pushbutton on the Sampling Head.

1. Check Fast Edge Pulse Amplitude

- Press the Autoset pushbutton on the 11801.
- Set the 11801 main size to 2 μ s/div by touching the horizontal (\longleftrightarrow) icon at the top of the crt and adjusting the upper control knob.
- CHECK - for a waveform on the display.
- Select the 11801 cursors by touching the Cursors icon at the top of the crt. Select the cursor type pop-up menu by touching the Cursor Type block on the main menu. Select horizontal bars by touching the Horizontal Bars block. Touch the Exit block to exit.
- Adjust the cursors using the upper and lower control knobs. Place one cursor on the top of the square wave and one cursor on the bottom of the square wave.
- CHECK - that (Δ)V is between 1.045 V and 1.155 V (inclusive). Record the amplitude for use in the following steps.
- Set the CG 5010/CG 5011 VARIABLE control to ON and rotate the VARIABLE knob to change the pulse amplitude on the crt.

h. CHECK — that the pulse amplitude may be adjusted to $\pm 10\%$ of the voltage measured in step f.

i. Set the CG 5010/CG 5011 EDGE POLARITY to (NEGATIVE)  and set the CG 5010/CG 5011 VARIABLE control to OFF.

j. Repeat parts a. through h.

2. Check Fast Edge Pulse Risetime

Maintain the same setup and settings as above with the exception of :

CG 5010/CG 5011:

VARIABLE	OFF
EDGE POLARITY	(POSITIVE) 

- Press the AUTOSET pushbutton on the 11801.
- Set the 11801 main size to 2 μ s/div by touching the horizontal (\longleftrightarrow) icon at the top of the crt and adjusting the upper control knob.
- Select the 11801 waveform main menu by pressing the Waveform pushbutton.
- Select the acquire description pop-up menu by touching the Acquire Desc block on the main menu.
- Select the waveform averaging by pressing the Average N block on the pop-up menu. Touch the Exit block to exit.
- Select the 11801 measurements main menu by pressing the Measure pushbutton.
- Select the measurements pop-up menu by touching the Measurements block on the main menu.
- Select the risetime measurement by pressing the Rise block on the pop-up menu. Touch the Exit Menu block to exit.
- Select the measurement mode pop-up menu by touching the Rise block on the main menu. Set Tracking to Off by touching the Tracking block on the pop-up menu. Touch the Rise block again to exit.
- Set the 11801 main size to 100 ps/div by adjusting the upper control knob.
- CHECK — that the risetime is less than or equal to 150 ps. Read the measured risetime below the Rise block on the 11801. See Fig. 4-1.

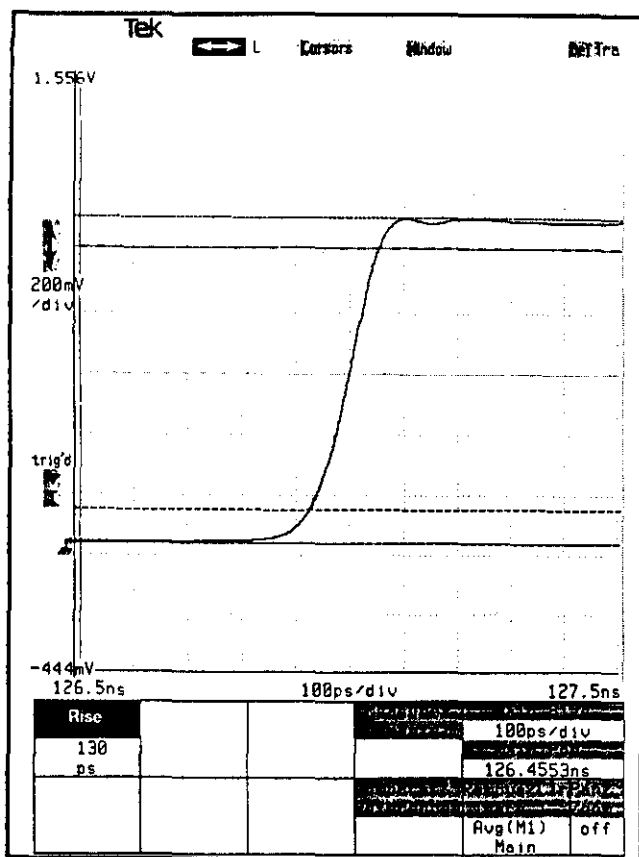



Fig. 4-1. Measurement of step 2 risetime.





- l. Set the CG 5010/CG 5011 EDGE POLARITY to (NEGATIVE) .
- m. Press the Autoset pushbutton on the 11801.
- n. Set the 11801 main size to 2 us/div by adjusting the upper control knob.
- o. Select the 11801 measurements pop-up menu by touching the Measurements block on the main menu.
- p. Deselect the risetime measurement by touching the Rise block on the pop-up menu. Select the falltime measurement by touching the Fall block on the pop-up menu. Touch the Exit Menu block to exit.
- q. Select the measurement mode pop-up menu by touching the Fall block on the main menu. Set Tracking to On by touching the Tracking block on the pop-up menu. Set Tracking to Off by touching the Tracking block on the pop-up menu. This will reset tracking and lock it on the new levels. Touch the Fall block again to exit.
- r. Set the 11801 main size to 100 ps/div by adjusting the upper control knob.
- s. CHECK — that the falltime is less than or equal to 150 ps. Read the measured falltime below the Fall block on the 11801.

3. Check Fast Edge Leading Edge Aberrations

Maintain the same setup and settings as above with the exception of :

CG 5010/CG 5011:

EDGE POLARITY (POSITIVE) 

- a. Press the Autoset pushbutton on the 11801.
- b. Set the 11801 main size to 500 ns/div by touching the horizontal () icon at the top of the crt and adjusting the upper control knob.
- c. Set the 11801 control knobs to vertical functions by touching the vertical () icon at the left of the crt. Place the top of the waveform on the center graticule by adjusting the vertical offset with the lower control knob.
- d. Set the 11801 vertical size to 10 mV/div by adjusting the upper control knob.
- e. Place the flattest portion of the waveform on the center graticule line by adjusting the vertical offset with the lower control knob.
- f. Set the 11801 main size to 1 ns/div by touching the horizontal () icon at the top of the crt and adjusting the upper control knob.
- g. Select cursors by touching the Cursors icon at the top of the crt.
- h. Adjust the cursors using the upper and lower control knobs. Place one cursor on the upper peak of the aberration and one cursor on the center graticule.
- i. CHECK — that the peak aberration (delta V) is less than 3% of the amplitude recorded in step 1. See Fig. 4-2.
- j. Place one cursor on the lower peak of the aberration and one cursor on the center graticule line.
- k. CHECK - that the peak aberration (delta V) is less than 3% of the amplitude recorded in step 1.
- l. Place the cursors on the two adjacent peaks which are the farthest apart vertically. Two peaks are adjacent if there is no change in the direction of the slope between them.
- m. CHECK — that the peak-to-peak aberration (delta V) is less than 4% of the amplitude recorded in step 1. See Fig. 4-3.
- n. Set the CG 5010/CG 5011 EDGE POLARITY to (NEGATIVE) .
- o. Press the Autoset pushbutton on the 11801.

**Section 4 – Pulse Head 015-0611-00
Performance Check Procedure**

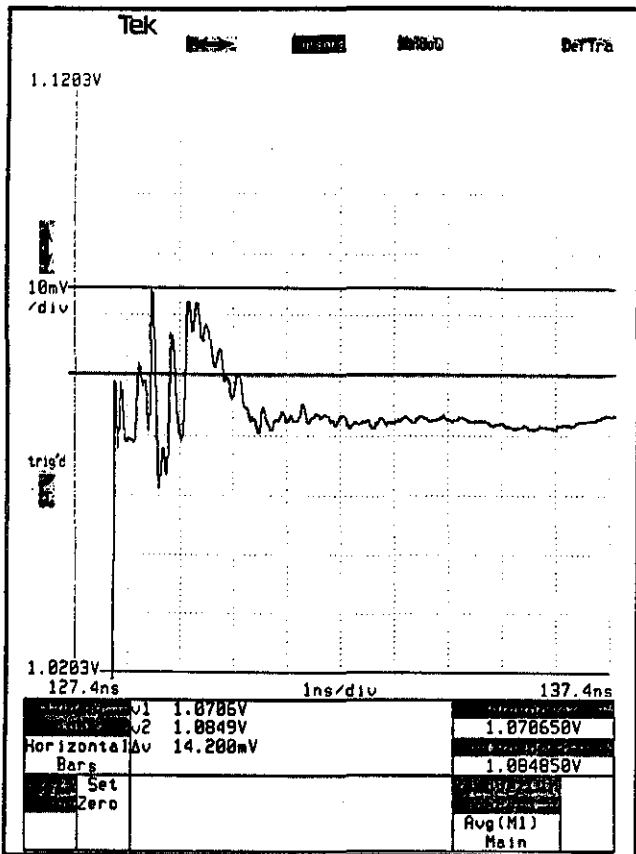

Fig. 4-2. Measurement of step 3 upper peak of aberration.

- p. Set the 11801 main size to 500 ns/div by touching the horizontal (↔) icon at the top of the crt and adjusting the upper control knob.
- q. Set the 11801 control knobs to vertical functions by touching the vertical (⇕) icon at the left of the crt. Place the bottom of the waveform on the center graticule by adjusting the vertical offset with the lower control knob.
- r. Set the 11801 vertical size to 10 mV/div by adjusting the upper control knob.
- s. Place the flattest portion of the waveform on the center graticule line by adjusting the vertical offset with the lower control knob.
- t. Set the 11801 main size to 1 ns/div by touching the horizontal (↔) icon at the top of the crt and adjusting the upper control knob.
- v. Repeat steps g. through m.

4. Check Fast Edge Pulse Frequency Output (100 Hz to 100 kHz)

Maintain the same setup and settings as above.

- a. Press the Autoset pushbutton on the 11801.

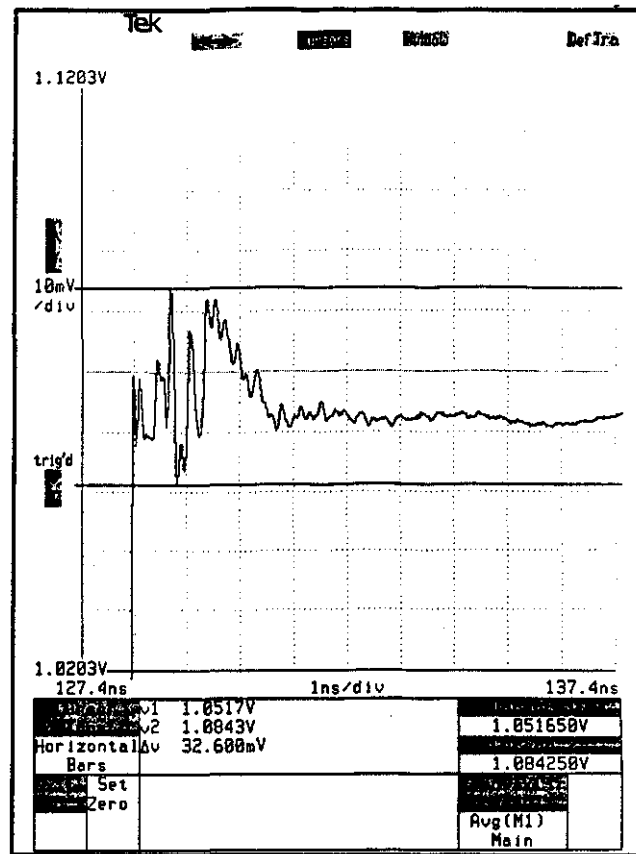

Fig. 4-3. Measurement of step 3 peak-to-peak aberration of adjacent peaks.

- b. Set the 11801 main size to 1 us/div by touching the horizontal (↔) icon at the top of the crt and adjusting the upper control knob.
- c. CHECK — for a displayed pulse.
- d. Set the CG 5010/CG 5011 FREQUENCY to 10 kHz.
- e. Set the 11801 main size to 10 us/div by adjusting the upper control knob.
- f. CHECK — for a displayed pulse.
- g. Set the CG 5010/CG 5011 FREQUENCY to 1 kHz.
- h. Set the 11801 main size to 100 us/div by adjusting the upper control knob.
- i. CHECK — for a displayed pulse.
- j. Set the CG 5010/CG 5011 FREQUENCY to 100 Hz.
- k. Set the 11801 main size to 1 ms/div by adjusting the upper control knob.
- l. CHECK — for a displayed pulse.

This completes the Performance Check Procedure.

ADJUSTMENT PROCEDURE

Introduction

Use this Adjustment Procedure to restore the Pulse Head to original factory calibration.

If this instrument has undergone repairs, the Adjustment procedure is recommended.

Test Equipment Required

Refer to Table 4-1 for applicable test equipment used in this procedure.



Preparation

Access to the internal adjustments is achieved with the Pulse Head top cover removed (see Maintenance Procedure in this manual).

After 30 minutes warm-up period, make Pulse Head adjustments at an ambient temperature between +20°C and +30°C (+68°F and +86°F).

Refer to Check Fast Edge Leading Edge Aberrations in the Performance Check (maintain same check set-up and control settings) when making following adjustments. See Adjustment Locations (Fig 8-3) in the fold-out section of this manual.

1. Adjust Positive Back Termination, R1200 and C1100 (located on Fast Edge board)

- a. Set CG 5010/CG 5011 EDGE POLARITY to (POSITIVE) .
- b. Press the Autoset pushbutton on the 11801.
- c. Set the 11801 main size to 500 ns/div by touching the horizontal () icon at the top of the crt and adjusting the upper control knob.

- d. Set the 11801 control knobs to vertical functions by touching the vertical () icon at the left of the crt. Place the top of the waveform on the center graticule by adjusting the vertical offset with the lower control knob.

- e. Set the 11801 vertical size to 10 mV/div by adjusting the upper control knob.

- f. Place the flattest portion of the waveform on the center graticule line by adjusting the vertical offset with the lower control knob.

- g. ADJUST — R1200 for maximum flatness of the displayed pulse top.

- h. ADJUST — C1100 to equalize the aberrations on each side of graticule center line.

Interaction between R1200 and C1100 may require slight readjustment to obtain the optimum displayed pulse.

- i. CHECK — displayed pulse for aberrations less than ±3% of pulse amplitude and adjacent pulse peaks not to exceed 4%, peak-to-peak.

2. Adjust Negative Back Termination, R1210 and C1110 (located on Fast Edge board)

- a. Set CG 5010/CG 5011 EDGE POLARITY to (NEGATIVE) .
- b. Repeat parts b through i of previous adjustment procedure (step 1), substituting R1210 and C1110 for the adjustment in steps 1g and 1h respectively.

This completes the Adjustment Procedure.

MAINTENANCE

Recalibration

To ensure accurate measurements, check the calibration of this instrument after each 1000 hours of operation or every six months if used infrequently. In addition, replacement of components may necessitate recalibration of the effected circuits. Refer to the Adjustment Procedure in the Calibration section.

Disassembly and Reassembly

NOTE

Refer to Fig. 5-1 for the following procedures:

Bottom Cover Removal and Replacement

- a. Remove cover screw ① and four end screws ②

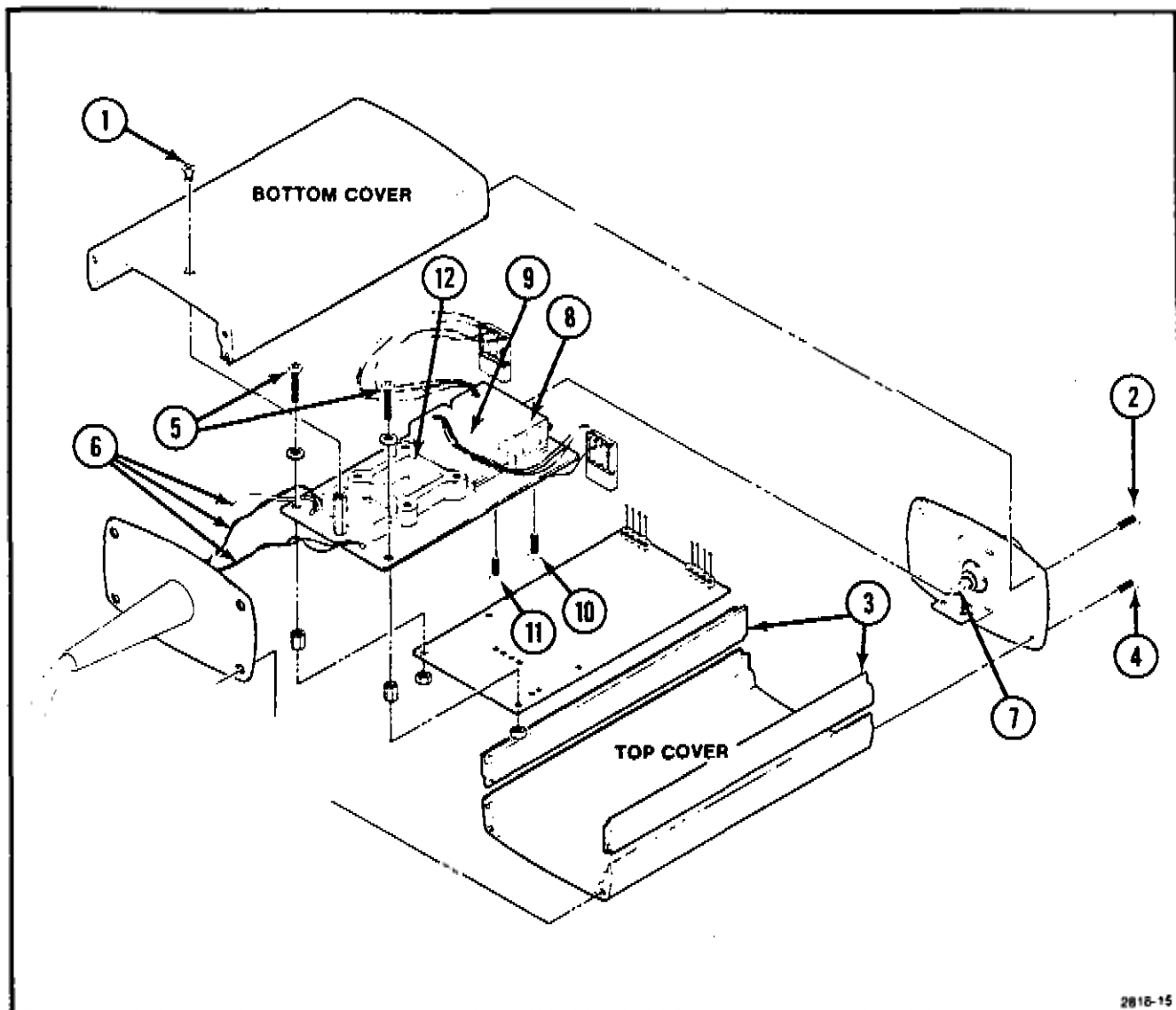

Fig. 5-1. Maintenance diagram (exploded view).

Maintenance – Pulse Head 015-0611-00

- b. Carefully lift top cover away from side rails ③. Remove side rails for better board access.
- c. To replace bottom cover, set side rails in place and position cover in the side rail grooves.
- d. Replace cover screw and four end screws.

Top Cover Removal and Replacement

- a. Remove four end screws ④.
- b. Carefully lift bottom cover away from side rails ③. Side rails can be removed, if desired.
- c. To replace top cover, set side rails in place and position cover in side rail grooves.
- d. Replace four end screws.

Hypcon Connector

The Hypcon Connector (hybrid-printed connector) is precision-made and designed to provide a low loss electrical and a thermally efficient connection between the printed circuit board and hybrid integrated circuit (see Fig. 5-2).

CAUTION

Care must be taken, when replacing the hybrid IC's, not to touch the elastomer gold-plated contacts or to use a cleaner which will degrade contact reliability.

The Hypcon Connector and hybrid IC (see Fig. 5-1, ⑫) should be removed if it is necessary to use a cleaning solvent near (1/2") the connector.

IMPORTANT

Remove all traces of solder flux or foreign material from the circuit board contact area before replacing the connector.

Contamination usually takes place during the soldering and cleaning process. Flux, oil, or other contaminants can be carried under the connector during the cleaning operation. When the solvent evaporates, nonconductive contaminants may remain on or near the contact interfaces.

The cleaning process, either hand cleaning with a solvent or machine cleaning in an automatic detergent wash, is **not** recommended for the board containing the Hypcon Connector.

If a component adjacent to the Hypcon Connector must be replaced, the following steps are recommended:

1. Remove the hybrid IC and Hypcon Connector before any soldering or cleaning, and store in a dirt free covered container. See Disassembly and Removal instructions.

2. Hand soldering recommendations:

- a. Use small diameter solder (0.030"-0.040").
- b. Use low power soldering irons (15-20 watts)
- c. Use care with solder amount and placement.

3. Remove solder flux and contact contamination with isopropyl alcohol or denatured alcohol.

4. Flush the hybrid and Hypcon Connector mounting area with isopropyl alcohol. Do not use cotton-tipped applicators. The elastomer should be examined for dust, hair, etc., before it is reinstalled.

If the etched circuit board surfaces require additional cleaning, scrub with a soft rubber eraser and blow or vacuum clean while dusting surface with a small clean brush.

5. If the hybrid IC and elastomer contact holder are contaminated, clean the contact holder and hybrid by flushing or spraying with alcohol and oven dry at +50°C. Do not scrub with a cotton tipped applicator or similar device. If the contact holder is excessively contaminated, replace it with a new one.

Make sure that the elastomer is properly seated in the contact holder before remounting the assembly to circuit board. Exercise care when mounting the plastic frame elastomer contact holder, and hybrid IC assembly to the circuit board to prevent misalignment between the connector and board.

CAUTION

Because of close tolerances involved, special care must be taken to assure correct index alignment of each Hypcon Connector part during reassembly. Failure to do so can result in a cracked hybrid substrate. See Fig. 5-2 for index locations.

A maximum of 2 inch pounds of torque should be applied to the mounting screws to secure the Hypcon Connector to the circuit board.

Disassembly and Removal

- a. Note index arrow on circuit board and Hypcon Connector plastic frame pointed mounting ear.
- b. Note screw locations then unscrew and remove the four screw and washer assemblies.
- c. Carefully lift the Hypcon Connector from the board.
- d. Note index location of hybrid and carefully remove the board with tweezers.
- e. Note index location of elastomer contact holder and remove by grasping a corner of the contact holder with tweezers and lifting up.

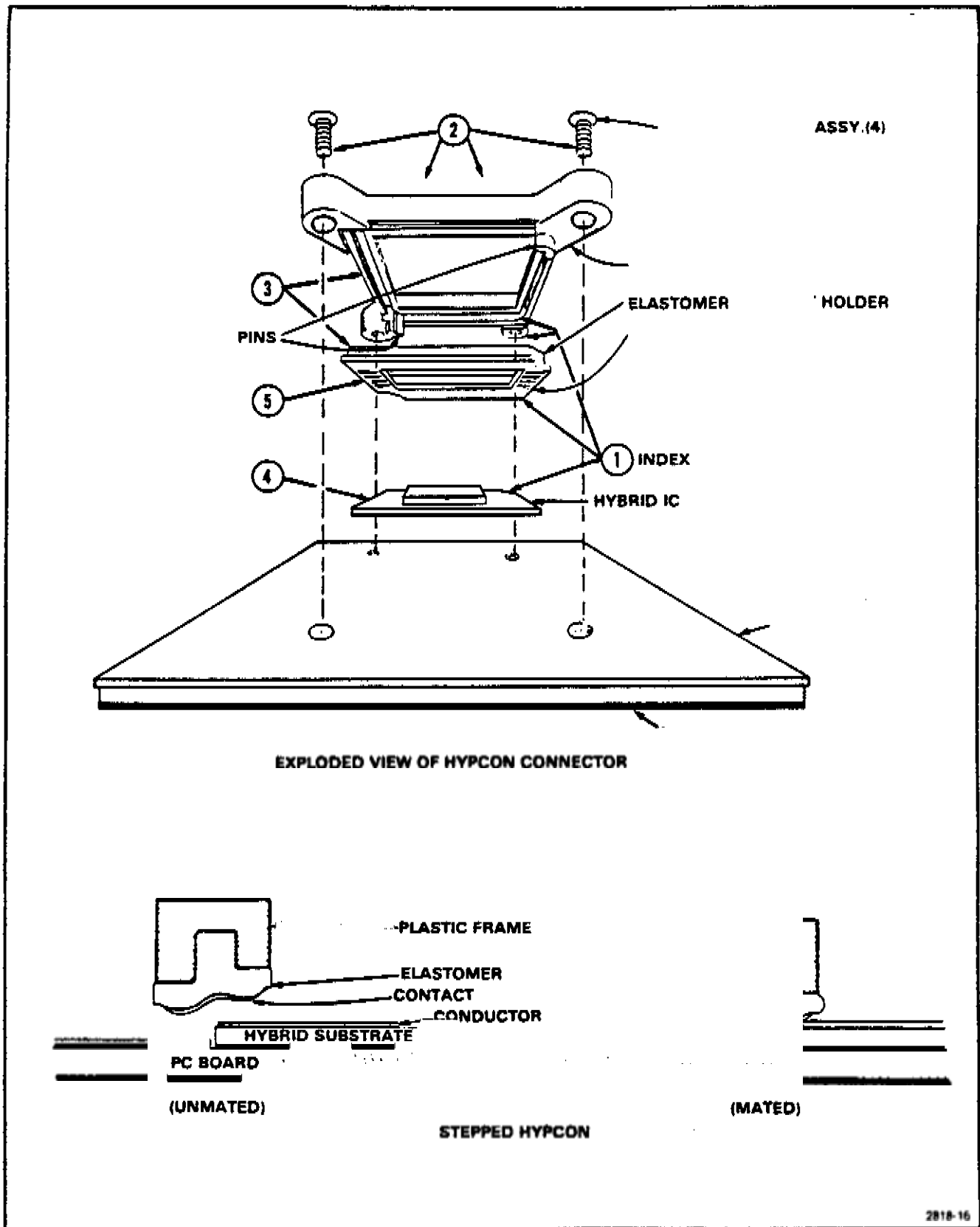

Fig. 5-2 Hypcon Connector (exploded view).

CAUTION

Avoid touching the hybrid and elastomer contact holder. Skin oils can be degrade reliability.

Reassembly and Replacement

a. Grasp corner of elastomer contact holder with tweezers and place holder in plastic frame slot using care to match the flat contact holder with the flat frame corner. Place a clean plastic envelope over finger and press to seat contact holder in the frame. The contact holder must be evenly seated on all four sides.

b. Match hybrid flat corner with board arrow. Line up the hybrid gold index runs with the circuit board runs.

c. Match pointed mounting ear of Hypcon Connector with flat corner of receptacle and guide registration pins into the board holes. Make certain the corners of hybrid line up with the corners of connector.

d. Insert mounting hardware and apply a maximum of 2 inch pounds of torque to secure the connector assembly.

NOTE

After replacement of Hypcon Connector, check the fast edge pulse for accuracy before attempting any adjustments. See Performance Check in the Calibration section.

Board Removal and Replacement (See Fig. 5-1).

After removing covers, siderails (see Cover Removal and Replacement) and coax connector and disconnecting log cell connectors (see Hypcon Connector). Remove the Fast Edge board and Fast Edge Driver board using the following procedure:

a. Remove the two screws ⑤ securing the Fast Edge board to the Fast Edge Driver board.

b. Pull the boards apart, using care not to bend any of the eight board interconnect pins.

c. To replace boards, line up the eight Fast Edge board interconnect pins with the Fast Edge Driver board pin sockets. Carefully insert the pins into their receptive sockets.

CAUTION

To force the pins into the sockets without proper alignment can cause damage to the pins and sockets.

d. After boards are properly connected together, replace the two screws.

Cable Removal and Replacement (from Fast Edge board)

a. After board removal, carefully unsolder the cable connections ⑥ and remove the cable.

b. To replace the cable, reverse above procedure.

Log Cell Removal and Replacement (Refer to Fig. 5-1)

Log Cell 1 Removal

a. Loosen two screws securing clamp ⑦. Slide clamp forward to expose coaxial center conductor.

b. With aid of a solder wick and tweezers, carefully unsolder wire connected to center conductor, detaching wire with tweezers. Removal of the two clamp screws detaches coaxial connector from board.

c. Note the log cell ⑧ wires lead dress to the board (essential for proper high frequency operation of the unit).

d. Using tweezers, unsolder the three board leads from the log cell.

e. Disconnect log cell vector. Unscrew four Fast Edge board screws ⑩ securing the log cell to board.

f. Carefully remove the log cell.

Log Cell 1 Replacement

a. Position log cell on board, lining up cell wires to their respective solder points on the board.

b. Replace the four Fast Edge board screws ⑩.

c. Using tweezers, properly dress log cell wire leads as close as possible to the board and carefully solder the connections.

d. Carefully solder center conductor wire connections and slide clamp over this solder connection and tighten clamp screws. Make certain center wire does not touch the clamp.

e. Attach the log cell connector.

Log Cell 2 Removal

a. Note log cell ⑨ wires dress with respect to the board.

b. Using tweezers, unsolder the four board leads from the log cell.

c. Disconnect log cell connector. Unscrew four Fast Edge-board screws ⑪ securing log cell to board.

d. Carefully remove the log cell.

Log Cell 2 Replacement

- a. Position log cell on board lining up cell wires to their respective solder points on board.
- b. Replace the four bottom board screws (1).
- c. Using tweezers, properly dress log cell wire leads to the board and carefully solder all connections.
- d. Attach the log cell connector.

Cleaning Instructions

This instrument should be cleaned as often as operating conditions require. Accumulation of dirt on components acts as an insulating blanket and prevents efficient heat dissipation that can cause overheating and component breakdown.

CAUTION

Avoid the use of chemical cleaning agents that might leave a film or damage the plastic material used in this instrument. Use a non-residue type of cleaner; preferably, isopropyl alcohol or totally denatured ethyl alcohol. Before using any other type of cleaner, consult your Tektronix Service Center or representative.

Exterior. Loose dust accumulated on the covers can be removed with a soft cloth or a small brush. Dirt that remains can be removed with a soft cloth dampened with a mild detergent and water solution. Abrasive cleaners should not be used.

Interior. Dust in the interior of the instrument should be removed occasionally due to its electrical conductivity under high humidity conditions. The best way to clean the interior is to blow off the accumulated dust with dry low pressure air; then use a soft brush.

After making minor board repairs, cleaning is best accomplished by carefully flaking or chipping the solder flux from the repaired area. See Hypcon Connector for further cleaning instructions.

Isopropyl alcohol can be used to clean major repairs to the circuit board. After cleaning, flush the board well with clean, isopropyl alcohol. Make certain that resin or dirt is carefully removed from the board.

Obtaining Replacement Parts

Electrical and mechanical parts can be obtained through your local Tektronix Field Office or representative. However, many of the standard electronic components are available from local commercial sources. Before purchasing or ordering parts from a source other than Tektronix, Inc., check the Replaceable Electrical Parts list for the proper value, rating, tolerance, and description.

Ordering Parts

When ordering replacement parts from Tektronix, Inc., it is important to include all of the following information:

1. Instrument type (include modification or option numbers).
2. Instrument serial number.
3. A description of the part (if electrical, include the component number).
4. Tektronix part number.

Static-Sensitive Components**CAUTION**

Static discharge may damage semiconductor components in this instrument.

This instrument contains electrical components that are susceptible to damage from static discharge. See Table 5-1 for relative susceptibility of various classes of semiconductors. Static voltages of 1 kV to 30 kV are common in unprotected environments.

Observe the following precautions to avoid damage:

1. Minimize handling of static-sensitive components.
2. Transport and store static-sensitive components or assemblies in their original containers on a metal rail, or on conductive foam. Label any package that contains static-sensitive assemblies or components.
3. Discharge the static voltage from your body by wearing a wrist strap while handling these components. Servicing static-sensitive assemblies or components should be performed only at a static-free work station by qualified service personnel.
4. Nothing capable of generating or holding a static charge should be allowed on the work station surface.
5. Keep the component leads shorted together whenever possible.
6. Pick up components by the body, never by the leads.
7. Do not slide the components over any surface.
8. Avoid handling components in areas that have a floor or work surface covering capable of generating a static charge.
9. Use a soldering iron that is connected to earth ground.
10. Use only special antistatic suction type or wick type desoldering tools.

Test Equipment

Before using any test equipment to make measurements on static-sensitive components or assemblies, be certain that any voltage or current supplied by the test equipment does not exceed the limits of the component to be tested.

**Table 5-1
RELATIVE SUSCEPTIBILITY TO
STATIC DISCHARGE DAMAGE**

Semiconductor Classes	Relative Susceptibility Levels*
MOS or CMOS microcircuits or discretes, or linear microcircuits with MOS inputs (Most Sensitive)	1
ECL	2
Schottky signal diodes	3
Schottky TTL	4
High-frequency bipolar transistors	5
JFETs	6
Linear microcircuits	7
Low-power Schottky TTL	8
TTL (Least Sensitive)	9

*Voltage equivalent for levels:

1=100 to 500 V	4=500 V	7=400 to 1000 V (est.)
2=200 to 500 V	5=400 to 600 V	8=800 V
3=250 V	6=600 to 800 V	9=1200 V

(Voltage discharged from a 100 pF capacitor through a resistance of 100 Ω.)

OPTIONS

There are no options available at this time.

REPLACEABLE ELECTRICAL PARTS

PARTS ORDERING INFORMATION

Replacement parts are available from or through your local Tektronix, Inc. Field Office or representative.

Changes to Tektronix instruments are sometimes made to accommodate improved components as they become available, and to give you the benefit of the latest circuit improvements developed in our engineering department. It is therefore important, when ordering parts, to include the following information in your order: Part number, instrument type or number, serial number, and modification number if applicable.

If a part you have ordered has been replaced with a new or improved part, your local Tektronix, Inc. Field Office or representative will contact you concerning any change in part number.

Change information, if any, is located at the rear of this manual.

LIST OF ASSEMBLIES

A list of assemblies can be found at the beginning of the Electrical Parts List. The assemblies are listed in numerical order. When the complete component number of a part is known, this list will identify the assembly in which the part is located.

CROSS INDEX-MFR. CODE NUMBER TO MANUFACTURER

The Mfr. Code Number to Manufacturer index for the Electrical Parts List is located immediately after this page. The Cross Index provides codes, names and addresses of manufacturers of components listed in the Electrical Parts List.

ABBREVIATIONS

Abbreviations conform to American National Standard Y1.1.

COMPONENT NUMBER (column one of the Electrical Parts List)

A numbering method has been used to identify assemblies, subassemblies and parts. Examples of this numbering method and typical expansions are illustrated by the following:

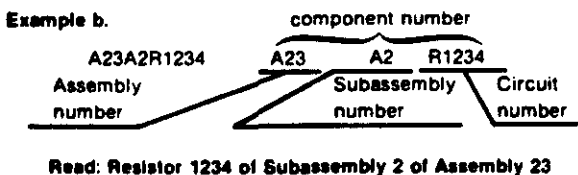
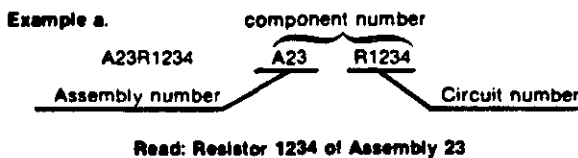

Only the circuit number will appear on the diagrams and circuit board illustrations. Each diagram and circuit board illustration is clearly marked with the assembly number. Assembly numbers are also marked on the mechanical exploded views located in the Mechanical Parts List. The component number is obtained by adding the assembly number prefix to the circuit number.

The Electrical Parts List is divided and arranged by assemblies in numerical sequence (e.g., assembly A1 with its subassemblies and parts, precedes assembly A2 with its subassemblies and parts).

Chassis-mounted parts have no assembly number prefix and are located at the end of the Electrical Parts List.

TEKTRONIX PART NO. (column two of the Electrical Parts List)

Indicates part number to be used when ordering replacement part from Tektronix.

SERIAL/MODEL NO. (columns three and four of the Electrical Parts List)

Column three (3) indicates the serial number at which the part was first used. Column four (4) indicates the serial number at which the part was removed. No serial number entered indicates part is good for all serial numbers.

NAME & DESCRIPTION (column five of the Electrical Parts List)

In the Parts List, an Item Name is separated from the description by a colon (:). Because of space limitations, an Item Name may sometimes appear as incomplete. For further Item Name identification, the U.S. Federal Cataloging Handbook H6-1 can be utilized where possible.

MFR. CODE (column six of the Electrical Parts List)

Indicates the code number of the actual manufacturer of the part. (Code to name and address cross reference can be found immediately after this page.)

MFR. PART NUMBER (column seven of the Electrical Parts List)

Indicates actual manufacturers part number.

Replaceable Electrical Parts
Pulse Head 015-0611-00

CROSS INDEX - MFR. CODE NUMBER TO MANUFACTURER

Mfr. Code	Manufacturer	Address	City, State, Zip Code
01121	ALLEN-BRADLEY CO	1201 SOUTH 2ND ST	MILWAUKEE WI 53204
03508	GENERAL ELECTRIC CO	W GENESEE ST	AUBURN NY 13021
	SEMI-CONDUCTOR PRODUCTS DEPT		
04222	AVX CERAMICS DIV OF AVX CORP	19TH AVE SOUTH P O BOX 867	MYRTLE BEACH SC 29577
04713	MOTOROLA INC	5005 E MCDOWELL RD	PHOENIX AZ 85008
	SEMICONDUCTOR GROUP		
12633	FIFTH DIMENSION INC	801 NEW YORK AVE	TRENTON NJ 08638
14433	ITT SEMICONDUCTORS DIV		WEST PALM BEACH FL
14552	MICRO/SEMICONDUCTOR CORP	2830 S FAIRVIEW ST	SANTA ANA CA 92704
15696	ELEC-TROL INC	26477 N GOLDEN VALLEY RD	SAUGUS CA 91350
19701	MEPCO/ELECTRA INC	P O BOX 760	MINERAL WELLS TX 76067
	A NORTH AMERICAN PHILIPS CO		
22526	DU PONT E I DE NEMOURS AND CO INC	515 FISHING CREEK RD	NEW CUMBERLAND PA 17070-3007
	DU PONT CONNECTOR SYSTEMS		
	DIV MILITARY PRODUCTS GROUP		
25403	PHILIPS COMPONENTS DISCRETE PRODUCTS	GEORGE WASHINGTON HWY	SMITHFIELD RI 02917
	DIV DISCRETE SEMICONDUCTOR GROUP		
32997	BOURNS INC	1200 COLUMBIA AVE	RIVERSIDE CA 92507
	TRIMPOT DIV		
50434	HEWLETT-PACKARD CO	640 PAGE MILL RD	PALO ALTO CA 94304
	OPTOELECTRONICS DIV		
57668	ROHM CORP	16931 MILLIKEN AVE	IRVINE CA 92713
59660	TUSONIX INC	2155 N FORBES BLVD	TUCSON, ARIZONA 85705
80009	TEKTRONIX INC	14150 SW KARL BRAUN DR P O BOX 500	BEAVERTON OR 97077-0001

Replaceable Electrical Parts
Pulse Head 015-0611-00

Component No.	Tektronix Part No.	Serial/Assembly No.		Name & Description	Mfr. Code	Mfr. Part No.
		Effective	Discont			
A20	671-2098-00			CIRCUIT BD ASSY:EDGE DRIVE	80009	671-2098-00
A22	671-1982-00			CIRCUIT BD ASSY FAST EDGE	80009	671-1982-00
A20	671-2098-00			CIRCUIT BD ASSY EDGE DRIVE	80009	671-2098-00
A20C1000	283-0177-00			CAP,FXD,CER DI:1UF,+80-20%,25V	04222	SR302E105ZAATR
A20C1001	283-0177-00			CAP,FXD,CER DI:1UF,+80-20% 25V	04222	SR302E105ZAATR
A20C1004	281-0331-00			CAP,FXD,CER DI:43PF,2%,100V	59660	513-011A1-5
A20C1011	283-0177-00			CAP,FXD,CER DI:1UF,+80-20%,25V	04222	SR302E105ZAATR
A20C1012	283-0177-00			CAP,FXD,CER DI:1UF,+80-20%,25V	04222	SR302E105ZAATR
A20C1013	283-0331-00			CAP,FXD,CER DI:43PF,2%,100V	59660	513-011A1-5
A20C1103	283-0164-00			CAP,FXD,CER DI:2.2UF,20%,25V	04222	SR402E225MAA
A20C1105	281-0811-00			CAP,FXD,CER DI:10PF,10%,100V	04222	MA101A100KAA
A20C1113	281-0811-00			CAP FXDCER DI:10PF, 10% 100V	04222	MA101A100KAA
A20CR1000	152-0536-00			SEMICON DVC,DI:SW,4V,C132	04713	SMV1110 (MBD101)
A20CR1002	152-0141-02			SEMICON DVC,DI:SW,SI,30V,150MA,30V	03508	DA2527 (1N4152)
A20CR1010	152-0536-00			SEMICON DVC,DI:SW,4V,C132	04713	SMV1110 (MBD101)
A20CR1011	152-0141-02			SEMICON DVC,DI:SW,SI,30V,150MA,30V	03508	DA2527 (1N4152)
A20CR1100	152-0141-02			SEMICON DVC,DI:SW,SI,30V,150MA,30V	03508	DA2527 (1N4152)
A20CR1103	152-0322-00			SEMICON DVC,DI:SCHOTTKY,SI,15V,DO-35	50434	5082-2672
A20CR1111	152-0141-02			SEMICON DVC,DI:SW,SI,30V,150MA,30V	03508	DA2527 (1N4152)
A20CR1116	152-0322-00			SEMICON DVC,DI:SCHOTTKY,SI,15V,DO-35	50434	5082-2672
A20CR1200	152-0141-02			SEMICON DVC,DI:SW,SI,30V,150MA,30V	03508	DA2527 (1N4152)
A20CR1203	152-0141-02			SEMICON DVC,DI:SW,SI,30V,150MA,30V	03508	DA2527 (1N4152)
A20CR1212	152-0141-02			SEMICON DVC,DI:SW,SI,30V,150MA,30V	03508	DA2527 (1N4152)
A20CR1213	152-0141-02			SEMICON DVC,DI:SW,SI,30V,150MA,30V	03508	DA2527 (1N4152)
A20J1204	131-0608-00			TERMINAL,PIN:0.365 L X 0.025 BRZ GLD PL (QUANTITY 4)	22526	48283-036
A20J1214	131-0608-00			TERMINAL,PIN:0.365 L X 0.025 BRZ GLD PL (QUANTITY 4)	22526	48283-036
A20P1002	136-0252-00			SOCKET,PIN CONN:SINGLE,PCB,T/G,0.030 H	22526	75060-012
A20P1004	136-0252-00			SOCKET,PIN CONN:SINGLE,PCB,T/G,0.030 H	22526	75060-012
A20P1005	136-0252-00			SOCKET,PIN CONN:SINGLE,PCB,T/G,0.030 H	22526	75060-012
A20P1007	136-0252-00			SOCKET,PIN CONN:SINGLE,PCB,T/G,0.030 H	22526	75060-012
A20P1009	136-0252-00			SOCKET,PIN CONN:SINGLE,PCB,T/G,0.030 H	22526	75060-012
A20P1012	136-0252-00			SOCKET,PIN CONN:SINGLE,PCB,T/G,0.030 H	22526	75060-012
A20P1013	136-0252-00			SOCKET,PIN CONN:SINGLE,PCB,T/G,0.030 H	22526	75060-012
A20P1014	136-0252-00			SOCKET,PIN CONN:SINGLE,PCB,T/G,0.030 H	22526	75060-012
A20Q1000	151-0441-00			TRANSISTOR:NPN,SI,TO-72	04713	SRF501
A20Q1001	151-0850-00			TRANSISTOR,SIG:BIPOLAR,PNP,15V,75MA	25403	BFC32M
A20Q1011	151-0851-00			TRANSISTOR,SIG:BIPOLAR,NPN,15V,75MA	25403	BFC63
A20Q1012	151-0434-00			TRANSISTOR:PNP,SI,TO-72	04713	SS7144
A20Q1101	151-0441-00			TRANSISTOR:NPN,SI,TO-72	04713	SRF501
A20Q1111	151-0434-00			TRANSISTOR:PNP,SI,TO-72	04713	SS7144
A20Q1200	151-0302-00			TRANSISTOR:NPN,SI,TO-18	04713	2N2222A
A20Q1202	151-0441-00			TRANSISTOR:NPN,SI,TO-72	04713	SRF501
A20Q1203	151-0301-00			TRANSISTOR:PNP,SI,TO-18	04713	ST898

Replaceable Electrical Parts
Pulse Head 015-0611-00

Component No.	Tektronix Part No.	Serial/Assembly No.		Name & Description	Mfr. Code	Mfr. Part No.
		Effective	Discont			
A20Q1211	151-0302-00			TRANSISTOR:NPN,SI,TO-18	04713	2N2222A
A20Q1212	151-0434-00			TRANSISTOR:PNP,SI,TO-72	04713	SS7144
A20Q1213	151-0301-00			TRANSISTOR:PNP,SI,TO-18	04713	5T898
A20R1000	315-0301-00			RES,FXD,FILM:300 OHM,5%,0.25W	57668	NTR25J-E300E
A20R1001	315-0390-00			RES,FXD,FILM:39 OHM,5%,0.25W	57668	NTR25J-E390E
A20R1002	315-0471-00			RES,FXD,FILM:470 OHM,5%,0.25W	57668	NTR25J-E470E
A20R1003	315-0610-00			RES,FXD,FILM:51 OHM,5%,0.25W	57668	NTR25J-E510E
A20R1004	317-0201-00			RES,FXD,CMPSPN:200 OHM,5%,0.125W	01121	BB2015
A20R1010	315-0390-00			RES,FXD,FILM:39 OHM,5%,0.25W	57668	NTR25J-E390E
A20R1011	315-0471-00			RES,FXD,FILM:470 OHM,5%,0.25W	57668	NTR25J-E470E
A20R1012	315-0610-00			RES,FXD,FILM:51 OHM,5%,0.25W	57668	NTR25J-E510E
A20R1013	317-0201-00			RES,FXD,CMPSPN:200 OHM,5%,0.125W	01121	BB2015
A20R1100	315-0471-00			RES,FXD,FILM:470 OHM,5%,0.25W	57668	NTR25J-E470E
A20R1101	315-0201-00			RES,FXD,FILM:200 OHM,5%,0.25W	57668	NTR25J-E200E
A20R1104	315-0471-00			RES,FXD,FILM:470 OHM,5%,0.25W	57668	NTR25J-E470E
A20R1106	315-0472-00			RES,FXD,FILM:4.7K OHM,5%,0.25W	57668	NTR25J-E04K7
A20R1107	315-0102-00			RES,FXD,FILM:1K OHM,5%,0.25W	57668	NTR25J-E01K0
A20R1111	315-0471-00			RES,FXD,FILM:470 OHM,5%,0.25W	57668	NTR25J-E470E
A20R1112	315-0472-00			RES,FXD,FILM:4.7K OHM,5%,0.25W	57668	NTR25J-E04K7
A20R1114	315-0471-00			RES,FXD,FILM:470 OHM,5%,0.25W	57668	NTR25J-E470E
A20R1115	315-0201-00			RES,FXD,FILM:200 OHM,5%,0.25W	57668	NTR25J-E200E
A20R1117	315-0471-00			RES,FXD,FILM:470 OHM,5%,0.25W	57668	NTR25J-E470E
A20R1118	315-0102-00			RES,FXD,FILM:1K OHM,5%,0.25W	57668	NTR25J-E01K0
A20R1200	315-0222-00			RES,FXD,FILM:2.2K OHM,5%,0.25W	57668	NTR25J-E02K2
A20R1201	315-0471-00			RES,FXD,FILM:470 OHM,5%,0.25W	57668	NTR25J-E470E
A20R1202	315-0472-00			RES,FXD,FILM:4.7K OHM,5%,0.25W	57668	NTR25J-E04K7
A20R1204	315-0272-00			RES,FXD,FILM:2.7K OHM,5%,0.25W	57668	NTR25J-E02K7
A20R1211	315-0272-00			RES,FXD,FILM:2.7K OHM,5%,0.25W	57668	NTR25J-E02K7
A20R1213	315-0472-00			RES,FXD,FILM:4.7K OHM,5%,0.25W	57668	NTR25J-E04K7
A20R1214	315-0471-00			RES,FXD,FILM:470 OHM,5%,0.25W	57668	NTR25J-E470E
A20VR1204	152-0127-00			SEMICOND DVC,DI:ZEN,SI,7.5V,5%,0.4W	14433	Z5347 (IN958B)
A20VR1205	152-0279-00			SEMICOND DVC,DI:ZEN,SI,5.1V,5%,0.4W	14552	TD3810989
A20VR1210	152-0279-00			SEMICOND DVC,DI:ZEN,SI,5.1V,5%,0.4W	14552	TD3810989
A20VR1211	152-0127-00			SEMICOND DVC,DI:ZEN,SI,7.5V,5%,0.4W	14433	Z5347 (IN958B)
A22	671-1982-00			CIRCUIT BD ASSY:FAST EDGE	80000	671-1982-00
A22C1100	281-0218-00			CAP,VAR,CER DI:1-5PF,+2-2.5%,100V	59660	513-011A1-5
A22C1110	281-0218-00			CAP,VAR,CER DI:1-5PF,+2-2.5%,100V	59660	513-011A1-5
A22J1002	131-0787-00			TERMINAL,PIN:0.64 L X 0.025 SQ PH BRZ	22526	47359-000
A22J1004	131-0787-00			TERMINAL,PIN:0.64 L X 0.025 SQ PH BRZ	22526	47359-000
A22J1005	131-0787-00			TERMINAL,PIN:0.64 L X 0.025 SQ PH BRZ	22526	47359-000
A22J1007	131-0787-00			TERMINAL,PIN:0.64 L X 0.025 SQ PH BRZ	22526	47359-000
A22J1009	131-0787-00			TERMINAL,PIN:0.64 L X 0.025 SQ PH BRZ	22526	47359-000
A22J1012	131-0787-00			TERMINAL,PIN:0.64 L X 0.025 SQ PH BRZ	22526	47359-000
A22J1013	131-0787-00			TERMINAL,PIN:0.64 L X 0.025 SQ PH BRZ	22526	47359-000

Replaceable Electrical Parts
Pulse Head 015-0611-00

Component No.	Tektronix Part No.	Serial/Assembly No.		Name & Description	Mfr. Code	Mfr. Part No.
		Effective	Discont			
A22J1014	131-0787-00			TERMINAL,PIN:0.64 L X 0.025 SQ PH BRZ	22526	47359-000
A22K1010	148-1019-00			RELAY,LATCHING:FDRM C,SPDT	12633	ORDER BY DESC
A22K1110	148-1019-00			RELAY,LATCHING:FORM C,SPDT	12633	ORDER BY DESC
A22K1210	148-0079-02			RELAY,REED:2 FORM A,110MA,28VDC	15636	R6738-1
A22R1200	311-0634-00			RES,VAR,NONIW:TRMR,	32997	3329H-L58-501
A22R1202	301-0271-00			RES,FXD,FILM:270 OHM,5%,0.5W	19701	5053CX270R0J
A22R1210	311-0634-00			RES,VAR,NONWW:TRMR,	32997	3329H-L58-501
A22U1112	165-2421-00			MICROCKT,DGTL:PULSAR HYBRID,	80009	165-2421-00

DIAGRAMS AND CIRCUIT BOARD ILLUSTRATIONS

Symbols

Graphic symbols and class designation letters are based on ANSI Standard Y32.2-1975.

Logic symbology is based on ANSI Y32.14-1973 in terms of positive logic. Logic symbols depict the logic function performed and may differ from the manufacturer's data.

The overline on a signal name indicates that the signal performs its intended function when it is in the low state.

Abbreviations are based on ANSI Y1.1-1972.

Other ANSI standards that are used in the preparation of diagrams by Tektronix, Inc. are:

Y14.15, 1966 Drafting Practices.
 Y14.2, 1973 Line Conventions and Lettering.
 Y10.5, 1968 Letter Symbols for Quantities Used in Electrical Science and Electrical Engineering.

American National Standard Institute
 1430 Broadway
 New York, New York 10018

Component Values

Electrical components shown on the diagrams are in the following units unless noted otherwise:

Capacitors = Values one or greater are in picofarads (pF).
 Values less than one are in microfarads (μ F).
 Resistors = Ohms (Ω).

The information and special symbols below may appear in this manual.

Assembly Numbers and Grid Coordinates

Each assembly in the instrument is assigned an assembly number (e.g., A20). The assembly number appears on the circuit board outline on the diagram, in the title for the circuit board component location illustration, and in the lookup table for the schematic diagram and corresponding component locator illustration. The Replaceable Electrical Parts list is arranged by assemblies in numerical sequence; the components are listed by component number *(see following illustration for constructing a component number).

The schematic diagram and circuit board component location illustration have grids. A lookup table with the grid coordinates is provided for ease of locating the component. Only the components illustrated on the facing diagram are listed in the lookup table. When more than one schematic diagram is used to illustrate the circuitry on a circuit board, the circuit board illustration may only appear opposite the first diagram on which it was illustrated; the lookup table will list the diagram number of other diagrams that the circuitry of the circuit board appears on.

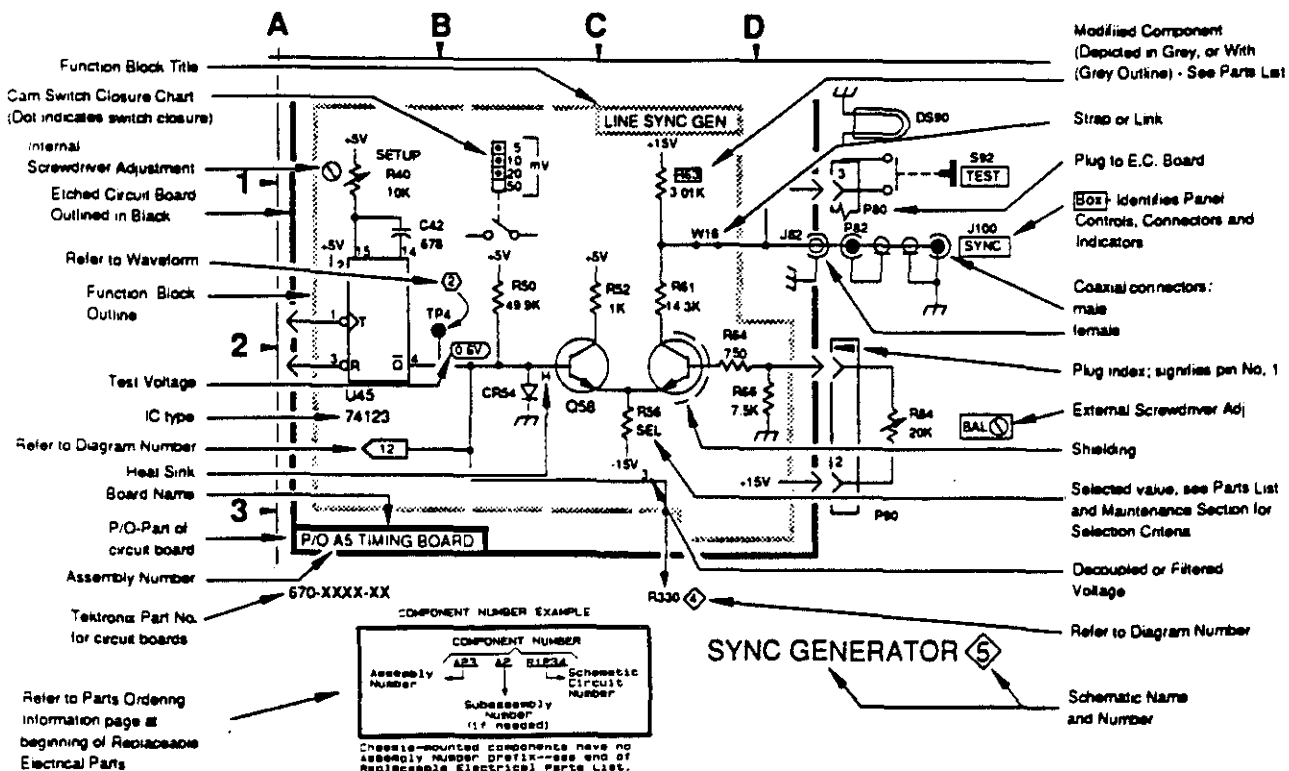

ADJUSTMENT LOCATIONS

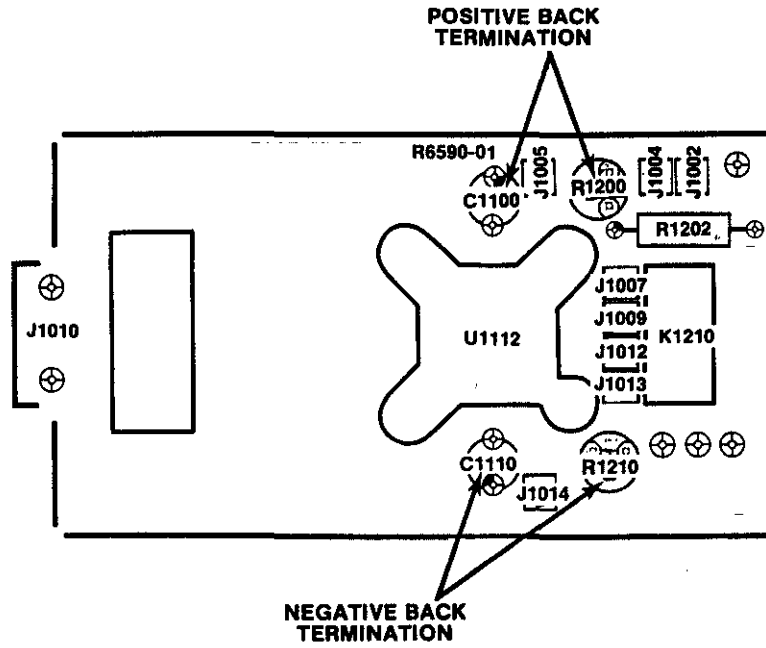
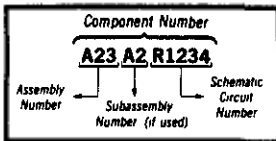

Fig. 8-3. Fast Edge board (A22).

 **Static Sensitive Devices**
See Maintenance Section

COMPONENT NUMBER EXAMPLE



Chassis-mounted components have no Assembly Number prefix—see end of Replaceable Electrical Parts List.

1	
2	
3	
1	
2	
3	

PARTS LOCATIONS

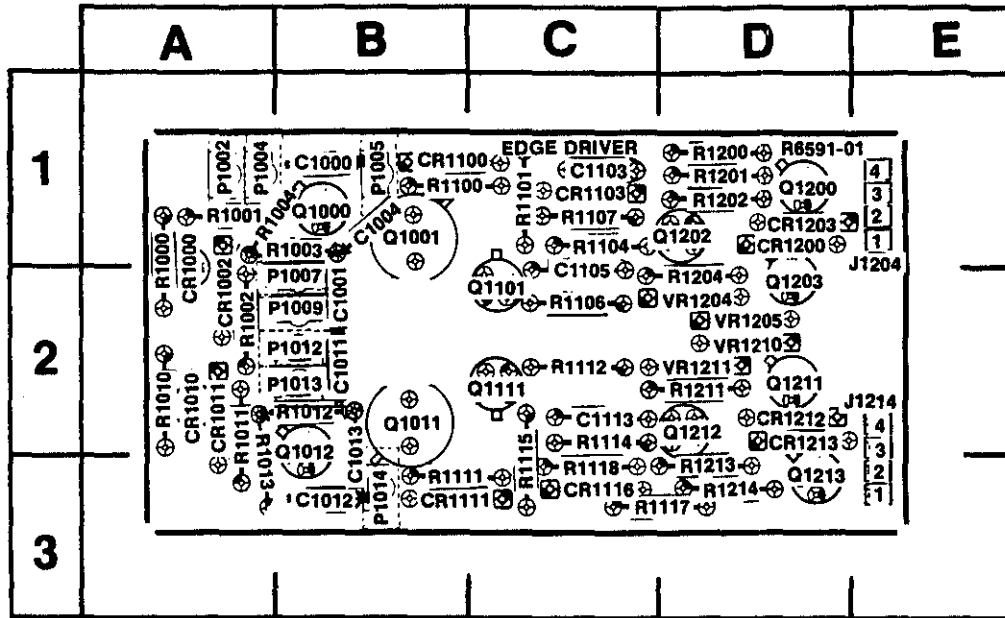

Fig. 8-1. Edge Driver board (A20).

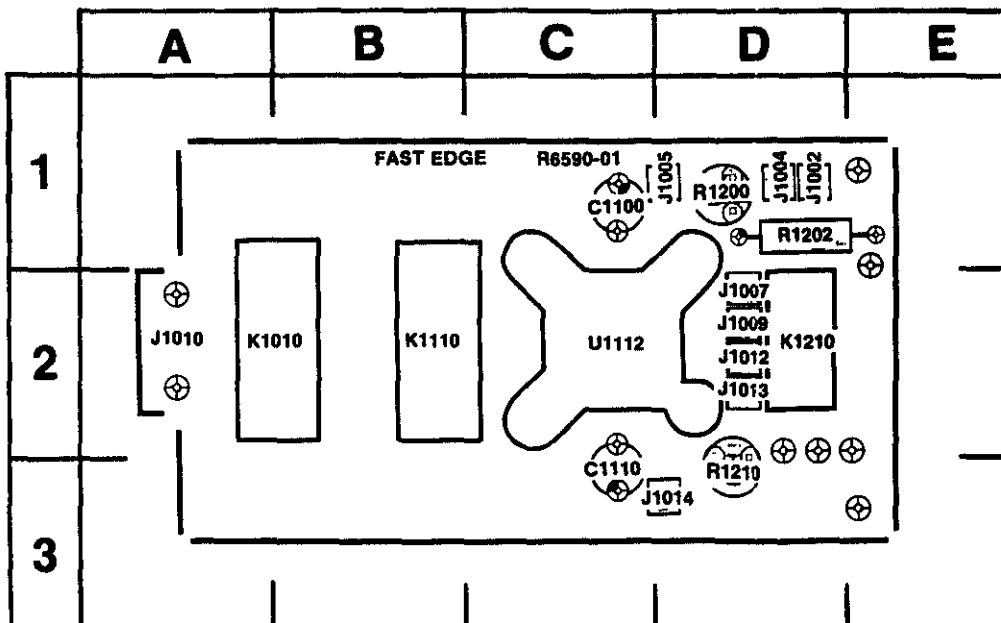
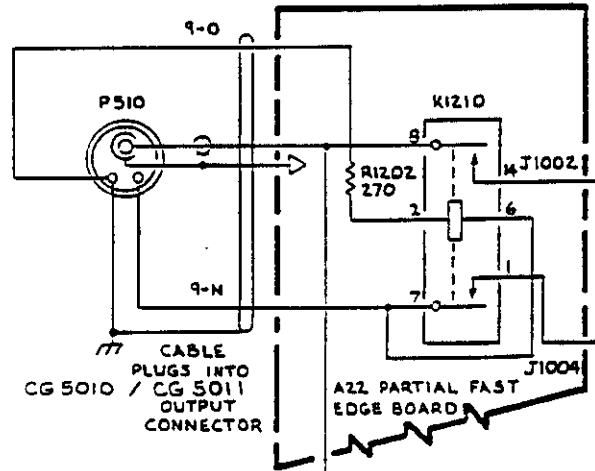

Fig. 8-2. Fast Edge board (A22).

PULSE HEAD
SMT. 10F2

A | B | C | D | E | F

1
—
2
—
3
—
4
—
5
—
6
—
7
—
8



⊗ Static Sensitive Devices
See Maintenance Section

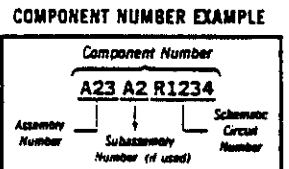

Class-mounted components have no Assembly Number prefix—see end of Replaceable Electrical Parts List.

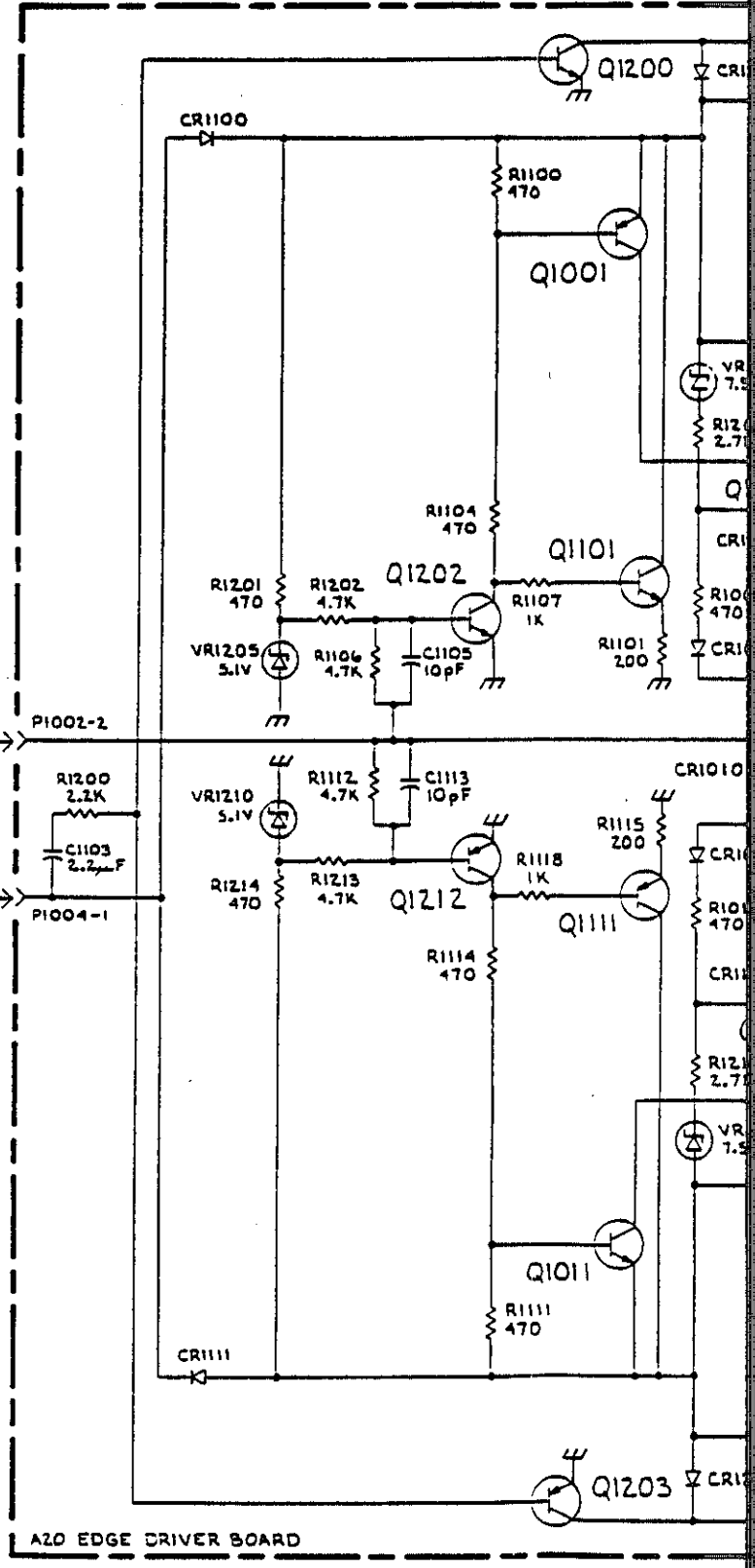

CG 5010 / CG 5011

REV AUG 1981
7893-20

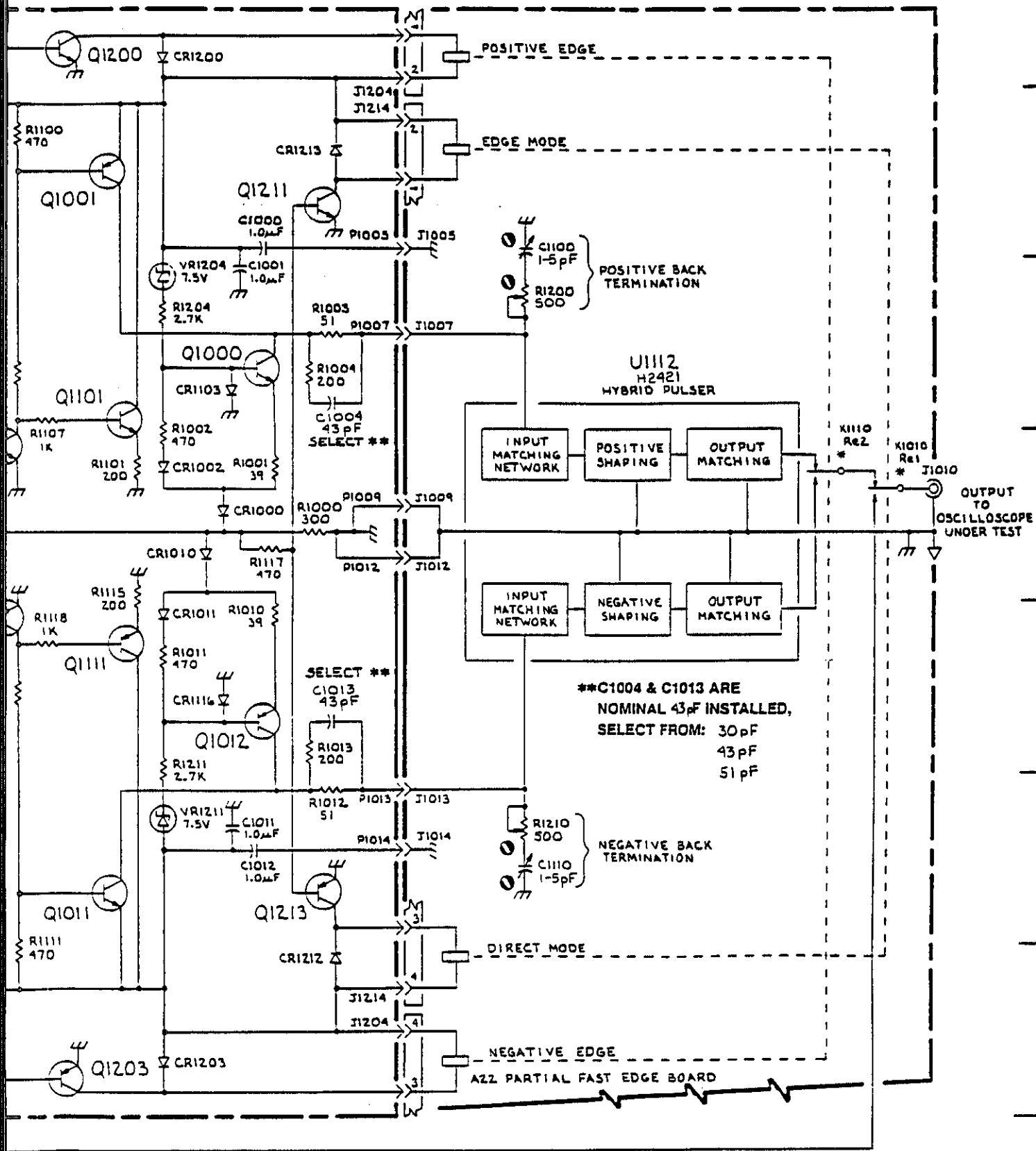

*SWITCH SHOWN IN POSITIVE EDGE & MODE POSITION

REPLACEABLE MECHANICAL PARTS

PARTS ORDERING INFORMATION

Replacement parts are available from or through your local Tektronix, Inc. Field Office or representative.

Changes to Tektronix instruments are sometimes made to accommodate improved components as they become available, and to give you the benefit of the latest circuit improvements developed in our engineering department. It is therefore important, when ordering parts, to include the following information in your order: Part number, instrument type or number, serial number, and modification number if applicable.

If a part you have ordered has been replaced with a new or improved part, your local Tektronix, Inc. Field Office or representative will contact you concerning any change in part number.

Change information, if any, is located at the rear of this manual.

ITEM NAME

In the Parts List, an Item Name is separated from the description by a colon (:). Because of space limitations, an Item Name may sometimes appear as incomplete. For further Item Name identification, the U.S. Federal Cataloging Handbook H6-1 can be utilized where possible.

FIGURE AND INDEX NUMBERS

Items in this section are referenced by figure and index numbers to the illustrations.

INDENTATION SYSTEM

This mechanical parts list is indented to indicate item relationships. Following is an example of the indentation system used in the description column.

1 2 3 4 5 Name & Description

Assembly and/or Component

Attaching parts for Assembly and/or Component

**** END ATTACHING PARTS ****

Detail Part of Assembly and/or Component

Attaching parts for Detail Part

**** END ATTACHING PARTS ****

Parts of Detail Part

Attaching parts for Parts of Detail Part

**** END ATTACHING PARTS ****

Attaching Parts always appear in the same indentation as the item it mounts, while the detail parts are indented to the right. Indented items are part of, and included with, the next higher indentation.

Attaching parts must be purchased separately, unless otherwise specified.

ABBREVIATIONS

INCH	NUMBER SIZE	ELECTRN	ELECTRON	IN	INCH	SE	SINGLE END
ACTR	ACTUATOR	ELEC	ELECTRICAL	INCAND	INCANDESCENT	SECT	SECTION
ADPTR	ADAPTER	ELECTLY	ELECTROLYTIC	INSUL	INSULATOR	SEMICOND	SEMICONDUCTOR
ALIGN	ALIGNMENT	ELEM	ELEMENT	INTL	INTERNAL	SHLD	SHIELD
AL	ALUMINUM	EPL	ELECTRICAL PARTS LIST	LPHLDR	LAMPHOLDER	SHLDR	SHOULDERED
ASSEM	ASSEMBLED	EOPT	EQUIPMENT	MACH	MACHINE	SKT	SOCKET
ASSY	ASSEMBLY	EXT	EXTERNAL	MECH	MECHANICAL	SL	SLIDE
ATTEN	ATTENUATOR	FIL	FILLISTER HEAD	MTG	MOUNTING	SLFLKG	SELF-LOCKING
AWG	AMERICAN WIRE GAGE	FLEX	FLEXIBLE	NIP	NIPPLE	SLVG	SLEEVING
BD	BOARD	FLH	FLAT HEAD	NON WIRE	NOT WIRE WOUND	SPR	SPRING
BRKT	BRACKET	FLTR	FILTER	OBD	ORDER BY DESCRIPTION	SQ	SQUARE
BRS	BRASS	FR	FRAME or FRONT	OD	OUTSIDE DIAMETER	SST	STAINLESS STEEL
BRZ	BRONZE	FSTNR	FASTENER	OVH	OVAL HEAD	STL	STEEL
BSHG	BUSHING	FT	FOOT	PH BRZ	PHOSPHOR BRONZE	SW	SWITCH
CAB	CABINET	FXD	FIXED	PL	PLAIN or PLATE	T	TUBE
CAP	CAPACITOR	GSKT	GASKET	PLSTC	PLASTIC	TERM	TERMINAL
CER	CERAMIC	HDL	HANDLE	PN	PART NUMBER	THD	THREAD
CHAS	CHASSIS	HEX	HEXAGON	PNH	PAN HEAD	THK	THICK
CKT	CIRCUIT	HEX HD	HEXAGONAL HEAD	PWR	POWER	TNSN	TENSION
COMP	COMPOSITION	HEX SOC	HEXAGONAL SOCKET	RCPT	RECEPTACLE	TPG	TAPPING
CONN	CONNECTOR	HLCPS	HELICAL COMPRESSION	RES	RESISTOR	TRH	TRUSS HEAD
COV	COVER	HLEXT	HELICAL EXTENSION	RGD	RIGID	V	VOLTAGE
CPLG	COUPLING	HV	HIGH VOLTAGE	RLF	RELIEF	VAR	VARIABLE
CRT	CATHODE RAY TUBE	IC	INTEGRATED CIRCUIT	RTNR	RETAINER	W/	WITH
DEG	DEGREE	ID	INSIDE DIAMETER	SCH	SOCKET HEAD	WSHR	WASHER
DWR	DRAWER	IDENT	IDENTIFICATION	SCOPE	OSCILLOSCOPE	XFMR	TRANSFORMER
		IMPLR	IMPELLER	SCR	SCREW	XSTR	TRANSISTOR

Replace Mechanical Parts
Pulse Head 015-0311-(01 & Up)

CROSS INDEX - MFR. CODE NUMBER TO MANUFACTURER

Mfr. Code	Manufacturer	Address	City, State, Zip Code
01536	TEXTRON INC CAMCAR DIV SEMS PRODUCTS UNIT	1818 CHRISTINA ST	ROCKFORD IL 61108
09772	WEST COAST LOCKWASHER CO INC	16730 E JOHNSON DRIVE P O BOX 3588	CITY OF INDUSTRY CA 91744
12327	FREEWAY CORP	9301 ALLEN DR	CLEVELAND OH 44125
22526	DU PONT E I DE NEMOURS AND CO INC DU PONT CONNECTOR SYSTEMS DIV MILITARY PRODUCTS GROUP	515 FISHING CREEK RD	NEW CUMBERLAND PA 17070-3007
46384	PENN ENGINEERING AND MFG CORP	P O BOX 311	DOYLESTOWN PA 18901
70318	ALLMETAL SCREW PRODUCTS CO INC	821 STEWART AVE	GARDEN CITY NY 11530
73743	FISCHER SPECIAL MFG CO	446 MORGAN ST	CINCINNATI OH 45206
77900	SHAKEPROOF DIV OF ILLINOIS TOOL WORKS	SAINT CHARLES RD	ELGIN IL 60120
80009	TEKTRONIX INC	4900 S W GRIFFITH DR P O BOX 500	BEAVERTON OR 97077
TK0435	LEWIS SCREW CO	4114 S PEORIA	CHICAGO IL 60609
TK0456	AROW FASTENERS INC	2112 AMERICAN AVE	HAYWARD CA 94545
TK1582	DELTA WEST CO	7185 SW SANDBURG ST SUITE C	TIGARD WA 97223

Replaceable Mechanical Parts
Pulse Head 015-0611-00

Fig. & Index No.	Tektronix Part No.	Serial/Assembly No. Effective Dscont	Qty	12345 Name & Description	Mfr. Code	Mfr. Part No.
1-1	204-2008-00		1	BODY HALF, PLS H:TOP (ATTACHING PARTS)	80009	204-0777-01
-2	211-0118-00		4	SCREW, MACHINE: 2-56 X 0.25, PNH, STL (END ATTACHING PARTS)	TK1582	1152-406
-3	386-6144-00		2	SPACER, PLATE: 0.156 X 3.875 X 0.468, AL	80009	361-0848-00
-4	204-0776-00		1	BODY HALF, PLS H:BOTTOM (ATTACHING PARTS)	80009	204-0776-00
-5	211-0118-00		4	SCREW, MACHINE: 2-56 X 0.25, PNH, STL	TK1582	1152-406
-6	211-0101-00		1	SCREW, MACHINE: 4-40 X 0.250, FLH, 100 DEG (END ATTACHING PARTS)	TK0435	ORDER BY DESCR
-7	175-2038-03		1	CA ASSY, SP, ELEC: 50 OHM COAX, 2.30 AWG, 1 METE R (ATTACHING PARTS)	80009	175-2038-03
-8	210-0583-00		1	NUT, PLAIN, HEX: 0.25-32 X 0.312, BRS CD PL	73743	2X-20319-402
-9	210-0046-00		1	WASHER, LOCK: 0.261 ID, INTL, 0.018 THK, STL (END ATTACHING PARTS)	77900	1214-05-00-0541C
-10	200-3858-00		1	COVER, END: REAR, PULSE HEAD	80009	200-2096-02
-10.1	211-0022-00		1	SCREW, MACHINE: 2-56 X 0.188, PNH, ST	TK0435	ORDER BY DESCR
-11	-----		1	.CKT BOARD ASSY: EDGE DRIVER (SEE A20 REPL) (ATTACHING PARTS)		
-12	220-0627-00		4	.NUT, PLAIN, HEX: 2-56 X 0.156 HEX, BRS NP	73743	10002-56-101
-13	210-1008-00		8	.WASHER, FLAT: 0.09 ID X 0.188 OD X 0.02, BRS	12327	ORDER BY DESCR
-14	211-0287-00		4	.SCREW, MACHINE: 2-56 X 0.5, PNH, SST	TK0456	ORDER BY DESCR
-15	129-0659-00		2	.SPACER, POST: 0.188 L, 2-56 THRU, AL, 0.188 HEX	80009	129-0659-00
-16	407-1983-02		1	.BRACKET, COAX: BRASS (END ATTACHING PARTS) .CKT BOARD ASSY INCLUDES:	80009	407-1983-01
-17	-----		8	..SOCKET, PIN TERM: (SEE A20P1002, P1004, P1005, ..P1007, P1009, P1012, P1013, P1014 REPL)		
-18	136-0252-00		6	..SOCKET, PIN CONN: W/O DIMPLE	22526	75060-012
-19	-----		8	..TERMINAL, PIN: (SEE A20J1204, J1214 REPL)		
-20	-----		1	.CKT BOARD ASSY: FAST EDGE (SEE A22 REPL)		
-21	-----		8	..TERMINAL, PIN: (SEE A22J1002, J1004, J1005, ..J1007, J1009, J1013, J1014 REPL)		
-22	-----		2	..RELAY, LATCHING: (SEE A22K1010, K1110 REPL) (ATTACHING PARTS)		
-23	211-0297-00		8	..SCREW, MACHINE: 0-80 X 0.312, FILH, SST (END ATTACHING PARTS)	70318	ORDER BY DESCR
-24	426-1337-00		1	..FRAME, MICROCKT: 1.22 CM (ATTACHING PARTS)	80009	426-1337-00
-25	211-0259-00		4	..SCR, ASSEM WSHR: 2-56 X 0.437, PNH, STL, POZ	01536	4821-00021
-26	220-0797-00		4	..NUT, CAPTIVE: 2-56 X 0.218 DIA, STL CD PL (END ATTACHING PARTS)	46384	KF2-256 CC
	131-1923-00		1	..CONTACT, ELEC: MICROCIRCUIT	80009	131-1923-00
-27	220-0449-00		1	.NUT, SLEEVE: 4-40 X 0.187 HEX, BRS CD PL (ATTACHING PARTS)	80009	220-0449-00
-28	211-0116-00		1	.SCR, ASSEM WSHR: 4-40 X 0.312, PNH, BRS, POZ (END ATTACHING PARTS)	77900	ORDER BY DESCR
-29	131-1778-04		1	.CONN, RCPT, ELEC: BNC, FEMALE, W/SHELL	80009	131-1778-02
-30	358-0072-00		1	.INSULATOR, BSHG: 0.192 ID X 0.192 OD X 0.323	80009	358-0072-00
-31	204-0755-00		1	.BODY, CONNECTOR: BNC, BRASS (ATTACHING PARTS)	80009	204-0755-00
-32	220-0495-00		1	.NUT, PLAIN, HEX: 0.375-32 X 0.438 HEX, BRS	73743	ORDER BY DESCR
-33	210-0012-00		1	.WASHER, LOCK: 0.384 ID, INTL, 0.022 THK, STL (END ATTACHING PARTS)	09772	ORDER BY DESCR
-34	220-0807-00		1	.NUT BLOCK: 2-56 X 0.60 X 0.58, AL	80009	220-0807-00
-35	131-2026-00		1	.CONTACT, ELEC: W/PIN TERMINAL SOCKET	80009	131-2026-01
-36	342-0381-00		1	.INSULATOR, BSHG: BNC, TEFLON	80009	342-0381-00
-37	103-0195-01		1	.ADAPTER, CONN: BNC TO CKT BD, W/RIGID COAX	80009	103-0195-01
-38	200-3859-00		1	.COVER, END: FRONT, PULSE HEAD	80009	200-2096-01
				STANDARD ACCESSORIES		
	070-7893-00		1	MANUAL, TECH: INSTRUCTION	80009	070-7893-00

FIG. 1 EXPLODED
PULSE HEAD 015-0611-00

