



Operating Manual

Two Line V-Network

R&S ENV216

3560.6550.06

Mains connector model: USA

Printed in the Federal
Republic of Germany

Index

**Datasheet
Safety Instructions
Certificate of Quality
Support Center Address
List of R&S Representatives
Contents**



Before putting the product into operation for the first time, make sure to read the following

Safety Instructions



All plants and locations of the Rohde & Schwarz group of companies make every effort to keep the safety standard of our products up to date and to offer our customers the highest possible degree of safety. Our products and the auxiliary equipment required for them are designed and tested in accordance with the relevant safety standards. Compliance with these standards is continuously monitored by our quality assurance system. The product described here has been designed and tested in accordance with the EC Certificate of Conformity and has left the manufacturer's plant in a condition fully complying with safety standards. To maintain this condition and to ensure safe operation, observe all instructions and warnings provided in this manual. If you have any questions regarding these safety instructions, the Rohde & Schwarz group of companies will be happy to answer them.

Furthermore, it is your responsibility to use the product in an appropriate manner. This product is designed for use solely in industrial and laboratory environments or in the field and must not be used in any way that may cause personal injury or property damage. You are responsible if the product is used for an intention other than its designated purpose or in disregard of the manufacturer's instructions. The manufacturer shall assume no responsibility for such use of the product.

The product is used for its designated purpose if it is used in accordance with its product documentation and within its performance limits (see data sheet, documentation, the following safety instructions). Using the product requires technical skills and a basic knowledge of English. It is therefore essential that the product be used exclusively by skilled and specialized staff or thoroughly trained personnel with the required skills. If personal safety gear is required for using Rohde & Schwarz products, this will be indicated at the appropriate place in the product documentation.

Symbols and safety labels

Observe product documentation	Weight indication for units >18 kg	Danger of electric shock	Warning! Hot surface	PE terminal	Ground	Ground terminal	Attention! Electrostatic sensitive devices

Supply voltage ON/OFF	Standby indication	Direct current (DC)	Alternating current (AC)	Direct/alternating current (DC/AC)	Device fully protected by double/reinforced insulation

Safety Instructions

Observing the safety instructions will help prevent personal injury or damage of any kind caused by dangerous situations. Therefore, carefully read through and adhere to the following safety instructions before putting the product into operation. It is also absolutely essential to observe the additional safety instructions on personal safety that appear in relevant parts of the product documentation. In these safety instructions, the word "product" refers to all merchandise sold and distributed by the Rohde & Schwarz group of companies, including instruments, systems and all accessories.

Tags and their meaning

DANGER	This tag indicates a definite hazard carrying a high risk of death or serious injury if not avoided.
WARNING	This tag indicates a possible hazard carrying a medium risk of death or (serious) injury if not avoided.
CAUTION	This tag indicates a hazard carrying a low risk of minor or moderate injury if not avoided.
ATTENTION	This tag indicates the possibility of incorrect use that can cause damage to the product.
NOTE	This tag indicates a situation where the user should pay special attention to operating the product but which does not lead to damage.

These tags are in accordance with the standard definition for civil applications in the European Economic Area. Definitions that deviate from the standard definition may also exist in other economic areas or military applications. It is therefore essential to make sure that the tags described here are always used only in connection with the related product documentation and the related product. The use of tags in connection with unrelated products or documentation can result in misinterpretation and thus contribute to personal injury or material damage.

Basic safety instructions

1. The product may be operated only under the operating conditions and in the positions specified by the manufacturer. Its ventilation must not be obstructed during operation. Unless otherwise specified, the following requirements apply to Rohde & Schwarz products:
prescribed operating position is always with the housing floor facing down, IP protection 2X, pollution severity 2, overvoltage category 2, use only in enclosed spaces, max. operation altitude 2000 m above sea level, max. transport altitude 4500 m above sea level.
Unless specified otherwise in the data sheet, a tolerance of $\pm 10\%$ shall apply to the nominal voltage and of $\pm 5\%$ to the nominal frequency.
2. Applicable local or national safety regulations and rules for the prevention of accidents must be observed in all work performed. The product may be opened only by authorized, specially trained personnel. Prior to performing any work on the product or opening the product, the product must be disconnected from the supply network. Any adjustments, replacements of parts, maintenance or repair must be carried out only by technical personnel authorized by Rohde & Schwarz. Only original parts may be used for replacing parts relevant to safety (e.g. power switches, power transformers, fuses). A safety test must always be performed after parts relevant to safety have been replaced (visual inspection, PE conductor test, insulation resistance measurement, leakage current measurement, functional test).
3. As with all industrially manufactured goods, the use of substances that induce an allergic reaction (allergens, e.g. nickel) such as aluminum cannot be generally excluded. If you develop an allergic reaction (such as a skin rash, frequent sneezing, red eyes or respiratory difficulties), consult a physician immediately to determine the cause.

Safety Instructions

4. If products/components are mechanically and/or thermally processed in a manner that goes beyond their intended use, hazardous substances (heavy-metal dust such as lead, beryllium, nickel) may be released. For this reason, the product may only be disassembled, e.g. for disposal purposes, by specially trained personnel. Improper disassembly may be hazardous to your health. National waste disposal regulations must be observed.
5. If handling the product yields hazardous substances or fuels that must be disposed of in a special way, e.g. coolants or engine oils that must be replenished regularly, the safety instructions of the manufacturer of the hazardous substances or fuels and the applicable regional waste disposal regulations must be observed. Also observe the relevant safety instructions in the product documentation.
6. Depending on the function, certain products such as RF radio equipment can produce an elevated level of electromagnetic radiation. Considering that unborn life requires increased protection, pregnant women should be protected by appropriate measures. Persons with pacemakers may also be endangered by electromagnetic radiation. The employer/operator is required to assess workplaces where there is a special risk of exposure to radiation and, if necessary, take measures to avert the danger.
7. Operating the products requires special training and intense concentration. Make certain that persons who use the products are physically, mentally and emotionally fit enough to handle operating the products; otherwise injuries or material damage may occur. It is the responsibility of the employer to select suitable personnel for operating the products.
8. Prior to switching on the product, it must be ensured that the nominal voltage setting on the product matches the nominal voltage of the AC supply network. If a different voltage is to be set, the power fuse of the product may have to be changed accordingly.
9. In the case of products of safety class I with movable power cord and connector, operation is permitted only on sockets with earthing contact and protective earth connection.
10. Intentionally breaking the protective earth connection either in the feed line or in the product itself is not permitted. Doing so can result in the danger of an electric shock from the product. If extension cords or connector strips are implemented, they must be checked on a regular basis to ensure that they are safe to use.
11. If the product has no power switch for disconnection from the AC supply, the plug of the connecting cable is regarded as the disconnecting device. In such cases, it must be ensured that the power plug is easily reachable and accessible at all times (corresponding to the length of connecting cable, approx. 2 m). Functional or electronic switches are not suitable for providing disconnection from the AC supply. If products without power switches are integrated in racks or systems, a disconnecting device must be provided at the system level.
12. Never use the product if the power cable is damaged. Check the power cable on a regular basis to ensure that it is in proper operating condition. By taking appropriate safety measures and carefully laying the power cable, ensure that the cable cannot be damaged and that no one can be hurt by e.g. tripping over the cable or suffering an electric shock.
13. The product may be operated only from TN/TT supply networks fused with max. 16 A (higher fuse only after consulting with the Rohde & Schwarz group of companies).
14. Do not insert the plug into sockets that are dusty or dirty. Insert the plug firmly and all the way into the socket. Otherwise, this can result in sparks, fire and/or injuries.
15. Do not overload any sockets, extension cords or connector strips; doing so can cause fire or electric shocks.
16. For measurements in circuits with voltages $V_{\text{rms}} > 30 \text{ V}$, suitable measures (e.g. appropriate measuring equipment, fusing, current limiting, electrical separation, insulation) should be taken to avoid any hazards.
17. Ensure that the connections with information technology equipment comply with IEC 950/EN 60950.
18. Unless expressly permitted, never remove the cover or any part of the housing while the product is in operation. Doing so will expose circuits and components and can lead to injuries, fire or damage to the product.

Safety Instructions

19. If a product is to be permanently installed, the connection between the PE terminal on site and the product's PE conductor must be made first before any other connection is made. The product may be installed and connected only by a license electrician.
20. For permanently installed equipment without built-in fuses, circuit breakers or similar protective devices, the supply circuit must be fused in such a way that suitable protection is provided for users and products.
21. Do not insert any objects into the openings in the housing that are not designed for this purpose. Never pour any liquids onto or into the housing. This can cause short circuits inside the product and/or electric shocks, fire or injuries.
22. Use suitable overvoltage protection to ensure that no overvoltage (such as that caused by a thunderstorm) can reach the product. Otherwise the operating personnel will be endangered by electric shocks.
23. Rohde & Schwarz products are not protected against penetration of water, unless otherwise specified (see also safety instruction 1.). If this is not taken into account, there exists the danger of electric shock for the user or damage to the product, which can also lead to personal injury.
24. Never use the product under conditions in which condensation has formed or can form in or on the product, e.g. if the product was moved from a cold to a warm environment.
25. Do not close any slots or openings on the product, since they are necessary for ventilation and prevent the product from overheating. Do not place the product on soft surfaces such as sofas or rugs or inside a closed housing, unless this is well ventilated.
26. Do not place the product on heat-generating devices such as radiators or fan heaters. The temperature of the environment must not exceed the maximum temperature specified in the data sheet.
27. Batteries and storage batteries must not be exposed to high temperatures or fire. Keep batteries and storage batteries away from children. Do not short-circuit batteries and storage batteries.
If batteries or storage batteries are improperly replaced, this can cause an explosion (warning: lithium cells). Replace the battery or storage battery only with the matching Rohde & Schwarz type (see spare parts list). Batteries and storage batteries must be recycled and kept separate from residual waste. Batteries and storage batteries that contain lead, mercury or cadmium are hazardous waste. Observe the national regulations regarding waste disposal and recycling.
28. Please be aware that in the event of a fire, toxic substances (gases, liquids etc.) that may be hazardous to your health may escape from the product.
29. The product can be very heavy. Be careful when moving it to avoid back or other physical injuries.
30. Do not place the product on surfaces, vehicles, cabinets or tables that for reasons of weight or stability are unsuitable for this purpose. Always follow the manufacturer's installation instructions when installing the product and fastening it to objects or structures (e.g. walls and shelves).
31. Handles on the products are designed exclusively for personnel to hold or carry the product. It is therefore not permissible to use handles for fastening the product to or on means of transport such as cranes, fork lifts, wagons, etc. The user is responsible for securely fastening the products to or on the means of transport and for observing the safety regulations of the manufacturer of the means of transport. Noncompliance can result in personal injury or material damage.
32. If you use the product in a vehicle, it is the sole responsibility of the driver to drive the vehicle safely. Adequately secure the product in the vehicle to prevent injuries or other damage in the event of an accident. Never use the product in a moving vehicle if doing so could distract the driver of the vehicle. The driver is always responsible for the safety of the vehicle. The manufacturer assumes no responsibility for accidents or collisions.
33. If a laser product (e.g. a CD/DVD drive) is integrated in a Rohde & Schwarz product, do not use any other settings or functions than those described in the product documentation. Otherwise this may be hazardous to your health, since the laser beam can cause irreversible damage to your eyes. Never try to take such products apart, and never look into the laser beam.

Informaciones de seguridad



Por favor lea imprescindiblemente antes de la primera puesta en funcionamiento las siguientes



Informaciones de seguridad

El principio del grupo de empresas Rohde & Schwarz consiste en tener nuestros productos siempre al día con los standards de seguridad y de ofrecer a nuestros clientes el máximo grado de seguridad. Nuestros productos y todos los equipos adicionales son siempre fabricados y examinados según las normas de seguridad vigentes. Nuestra sección de gestión de la seguridad de calidad controla constantemente que sean cumplidas estas normas. El presente producto ha sido fabricado y examinado según el comprobante de conformidad adjunto según las normas de la CE y ha salido de nuestra planta en estado impecable según los standards técnicos de seguridad. Para poder preservar este estado y garantizar un funcionamiento libre de peligros, el usuario deberá atenerse a todas las informaciones, informaciones de seguridad y notas de alerta. El grupo de empresas Rohde & Schwarz está siempre a su disposición en caso de que tengan preguntas referentes a estas informaciones de seguridad.

Además queda en la responsabilidad del usuario utilizar el producto en la forma debida. Este producto solamente fue elaborado para ser utilizado en la industria y el laboratorio o para fines de campo y de ninguna manera deberá ser utilizado de modo que alguna persona/cosa pueda ser dañada. El uso del producto fuera de sus fines definidos o despreciando las informaciones de seguridad del fabricante queda en la responsabilidad del usuario. El fabricante no se hace en ninguna forma responsable de consecuencias a causa del mal uso del producto.

Se parte del uso correcto del producto para los fines definidos si el producto es utilizado dentro de las instrucciones de la correspondiente documentación de producto y dentro del margen de rendimiento definido (ver hoja de datos, documentación, informaciones de seguridad que siguen). El uso del producto hace necesarios conocimientos profundos y conocimientos parciales del idioma inglés. Por eso se deberá tener en cuenta de exclusivamente autorizar para el uso del producto a personas peritas o debidamente minuciosamente instruidas con los conocimientos citados. Si fuera necesaria indumentaria de seguridad para el uso de productos de R&S, encontrará la información debida en la documentación del producto en el capítulo correspondiente.

Símbolos y definiciones de seguridad

Ver documentación de producto	Informaciones para maquinaria con un peso de > 18kg	Peligro de golpe de corriente	¡Advertencia! Superficie caliente	Conexión a conductor protector	Conexión a tierra	Conexión a masa conductora	¡Cuidado! Elementos de construcción con peligro de carga electrostática

potencia EN MARCHA/PARADA	Indicación Stand-by	Corriente continua DC	Corriente alterna AC	Corriente continua/alterna DC/AC	El aparato está protegido en su totalidad por un aislamiento de doble refuerzo

Informaciones de seguridad

Tener en cuenta las informaciones de seguridad sirve para tratar de evitar daños y peligros de toda clase. Es necesario de que se lean las siguientes informaciones de seguridad concienzudamente y se tengan en cuenta debidamente antes de la puesta en funcionamiento del producto. También deberán ser tenidas en cuenta las informaciones para la protección de personas que encontrarán en el capítulo correspondiente de la documentación de producto y que también son obligatorias de seguir. En las informaciones de seguridad actuales hemos juntado todos los objetos vendidos por el grupo de empresas Rohde & Schwarz bajo la denominación de „producto“, entre ellos también aparatos, instalaciones así como toda clase de accesorios.

Palabras de señal y su significado

PELIGRO	Identifica un peligro directo con riesgo elevado de provocar muerte o lesiones de gravedad si no se toman las medidas oportunas.
ADVERTENCIA	Identifica un posible peligro con riesgo medio de provocar muerte o lesiones (de gravedad) si no se toman las medidas oportunas.
ATENCIÓN	Identifica un peligro con riesgo reducido de provocar lesiones de gravedad media o leve si no se toman las medidas oportunas.
CUIDADO	Indica la posibilidad de utilizar mal el producto y a consecuencia dañarlo.
INFORMACIÓN	Indica una situación en la que deberían seguirse las instrucciones en el uso del producto, pero que no consecuentemente deben de llevar a un daño del mismo.

Las palabras de señal corresponden a la definición habitual para aplicaciones civiles en el área económica europea. Pueden existir definiciones diferentes a esta definición en otras áreas económicas o en aplicaciones militares. Por eso se deberá tener en cuenta que las palabras de señal aquí descritas sean utilizadas siempre solamente en combinación con la correspondiente documentación de producto y solamente en combinación con el producto correspondiente. La utilización de las palabras de señal en combinación con productos o documentaciones que no les correspondan puede llevar a malinterpretaciones y tener por consecuencia daños en personas u objetos.

Informaciones de seguridad elementales

1. El producto solamente debe ser utilizado según lo indicado por el fabricante referente a la situación y posición de funcionamiento sin que se obstruya la ventilación. Si no se convino de otra manera, es para los productos R&S válido lo que sigue: como posición de funcionamiento se define principalmente la posición con el suelo de la caja para abajo, modo de protección IP 2X, grado de suciedad 2, categoría de sobrecarga eléctrica 2, utilizar solamente en estancias interiores, utilización hasta 2000 m sobre el nivel del mar, transporte hasta 4.500 m sobre el nivel del mar. A menos que se especifique otra cosa en la hoja de datos, se aplicará una tolerancia de $\pm 10\%$ sobre el voltaje nominal y de $\pm 5\%$ sobre la frecuencia nominal.
2. En todos los trabajos deberán ser tenidas en cuenta las normas locales de seguridad de trabajo y de prevención de accidentes. El producto solamente debe de ser abierto por personal perito autorizado. Antes de efectuar trabajos en el producto o abrirlo deberá este ser desconectado de la corriente. El ajuste, el cambio de partes, la manutención y la reparación deberán ser solamente efectuadas por electricistas autorizados por R&S. Si se reponen partes con importancia para los aspectos de seguridad (por ejemplo el enchufe, los transformadores o los fusibles), solamente podrán ser sustituidos por partes originales. Después de cada recambio de partes elementales para la seguridad deberá ser efectuado un control de seguridad (control a primera vista, control de conductor protector, medición de resistencia de aislamiento, medición de medición de la corriente conductora, control de funcionamiento).

Informaciones de seguridad

3. Como en todo producto de fabricación industrial no puede ser excluido en general de que se produzcan al usarlo elementos que puedan generar alergias, los llamados elementos alergénicos (por ejemplo el níquel). Si se produjeran en el trato con productos R&S reacciones alérgicas, como por ejemplo urticaria, estornudos frecuentes, irritación de la conjuntiva o dificultades al respirar, se deberá consultar inmediatamente a un médico para averiguar los motivos de estas reacciones.
4. Si productos / elementos de construcción son tratados fuera del funcionamiento definido de forma mecánica o térmica, pueden generarse elementos peligrosos (polvos de sustancia de metales pesados como por ejemplo plomo, berilio, níquel). La partición elemental del producto, como por ejemplo sucede en el tratamiento de materias residuales, debe de ser efectuada solamente por personal especializado para estos tratamientos. La partición elemental efectuada inadecuadamente puede generar daños para la salud. Se deben tener en cuenta las directivas nacionales referentes al tratamiento de materias residuales.
5. En el caso de que se produjeran agentes de peligro o combustibles en la aplicación del producto que debieran de ser transferidos a un tratamiento de materias residuales, como por ejemplo agentes refrigerantes que deben ser repuestos en periodos definidos, o aceites para motores, deberán ser tenidas en cuenta las prescripciones de seguridad del fabricante de estos agentes de peligro o combustibles y las regulaciones regionales para el tratamiento de materias residuales. Cuiden también de tener en cuenta en caso dado las prescripciones de seguridad especiales en la descripción del producto.
6. Ciertos productos, como por ejemplo las instalaciones de radiación HF, pueden a causa de su función natural, emitir una radiación electromagnética aumentada. En vista a la protección de la vida en desarrollo deberían ser protegidas personas embarazadas debidamente. También las personas con un bypass pueden correr peligro a causa de la radiación electromagnética. El empresario/usuario está comprometido a valorar y señalar áreas de trabajo en las que se corra un riesgo aumentado de exposición a radiaciones para evitar riesgos.
7. La utilización de los productos requiere instrucciones especiales y una alta concentración en el manejo. Debe de ponerse por seguro de que las personas que manejen los productos estén a la altura de los requerimientos necesarios referente a sus aptitudes físicas, psíquicas y emocionales, ya que de otra manera no se pueden excluir lesiones o daños de objetos. El empresario lleva la responsabilidad de seleccionar el personal usuario apto para el manejo de los productos.
8. Antes de la puesta en marcha del producto se deberá tener por seguro de que la tensión preseleccionada en el producto equivalga a la de la red de distribución. Si es necesario cambiar la preselección de la tensión también se deberán en caso de cambio cambiar los fusibles correspondientes del producto.
9. Productos de la clase de seguridad I con alimentación móvil y enchufe individual de producto solamente deberán ser conectados para el funcionamiento a tomas de corriente de contacto de seguridad y con conductor protector conectado.
10. Queda prohibida toda clase de interrupción intencionada del conductor protector, tanto en la toma de corriente como en el mismo producto. Puede tener como consecuencia el peligro de golpe de corriente por el producto. Si se utilizaran cables o enchufes de extensión se deberá poner al seguro, que es controlado su estado técnico de seguridad.
11. Si el producto no está equipado con un interruptor para desconectarlo de la red, se deberá considerar el enchufe del cable de distribución como interruptor. En estos casos deberá asegurarse de que el enchufe sea de fácil acceso y nabejo (según la medida del cable de distribución, aproximadamente 2 m). Los interruptores de función o electrónicos no son aptos para el corte de la red eléctrica. Si los productos sin interruptor están integrados en construcciones o instalaciones, se deberá instalar el interruptor al nivel de la instalación.

Informaciones de seguridad

12. No utilice nunca el producto si está dañado el cable eléctrico. Compruebe regularmente el correcto estado de los cables de conexión a red. Asegure a través de las medidas de protección y de instalación adecuadas de que el cable de eléctrico no pueda ser dañado o de que nadie pueda ser dañado por él, por ejemplo al tropezar o por un golpe de corriente.
13. Solamente está permitido el funcionamiento en redes de distribución TN/TT aseguradas con fusibles de como máximo 16 A (utilización de fusibles de mayor amperaje sólo previa consulta con el grupo de empresas Rohde & Schwarz).
14. Nunca conecte el enchufe en tomas de corriente sucias o llenas de polvo. Introduzca el enchufe por completo y fuertemente en la toma de corriente. Si no tiene en consideración estas indicaciones se arriesga a que se originen chispas, fuego y/o heridas.
15. No sobrecargue las tomas de corriente, los cables de extensión o los enchufes de extensión ya que esto pudiera causar fuego o golpes de corriente.
16. En las mediciones en circuitos de corriente con una tensión de entrada de $U_{\text{eff}} > 30 \text{ V}$ se deberá tomar las precauciones debidas para impedir cualquier peligro (por ejemplo medios de medición adecuados, seguros, limitación de tensión, corte protector, aislamiento etc.).
17. En caso de conexión con aparatos de la técnica informática se deberá tener en cuenta que estos cumplan los requisitos de la EC950/EN60950.
18. A menos que esté permitido expresamente, no retire nunca la tapa ni componentes de la carcasa mientras el producto esté en servicio. Esto pone a descubierto los cables y componentes eléctricos y puede causar heridas, fuego o daños en el producto.
19. Si un producto es instalado fijamente en un lugar, se deberá primero conectar el conductor protector fijo con el conductor protector del aparato antes de hacer cualquier otra conexión. La instalación y la conexión deberán ser efectuadas por un electricista especializado.
20. En caso de que los productos que son instalados fijamente en un lugar sean sin protector implementado, autointerruptor o similares objetos de protección, el circuito de suministro de corriente deberá estar protegido de manera que usuarios y productos estén suficientemente protegidos.
21. Por favor, no introduzca ningún objeto que no esté destinado a ello en los orificios de la caja del aparato. No vierta nunca ninguna clase de líquidos sobre o en la caja. Esto puede producir corto circuitos en el producto y/o puede causar golpes de corriente, fuego o heridas.
22. Asegúrese con la protección adecuada de que no pueda originarse en el producto una sobrecarga por ejemplo a causa de una tormenta. Si no se verá el personal que lo utilice expuesto al peligro de un golpe de corriente.
23. Los productos R&S no están protegidos contra el agua si no es que exista otra indicación, ver también punto 1. Si no se tiene en cuenta esto se arriesga el peligro de golpe de corriente para el usuario o de daños en el producto lo cual también puede llevar al peligro de personas.
24. No utilice el producto bajo condiciones en las que pueda producirse y se hayan producido líquidos de condensación en o dentro del producto como por ejemplo cuando se desplaza el producto de un lugar frío a un lugar caliente.
25. Por favor no cierre ninguna ranura u orificio del producto, ya que estas son necesarias para la ventilación e impiden que el producto se caliente demasiado. No pongan el producto encima de materiales blandos como por ejemplo sofás o alfombras o dentro de una caja cerrada, si esta no está suficientemente ventilada.
26. No ponga el producto sobre aparatos que produzcan calor, como por ejemplo radiadores o calentadores. La temperatura ambiental no debe superar la temperatura máxima especificada en la hoja de datos.

Informaciones de seguridad

27. Baterías y acumuladores no deben de ser expuestos a temperaturas altas o al fuego. Guardar baterías y acumuladores fuera del alcance de los niños. No cortocircuitar baterías ni acumuladores. Si las baterías o los acumuladores no son cambiados con la debida atención existirá peligro de explosión (atención celulas de Litio). Cambiar las baterías o los acumuladores solamente por los del tipo R&S correspondiente (ver lista de piezas de recambio). Las baterías y acumuladores deben reutilizarse y no deben acceder a los vertederos. Las baterías y acumuladores que contienen plomo, mercurio o cadmio deben tratarse como residuos especiales. Respete en esta relación las normas nacionales de evacuación y reciclaje.
28. Por favor tengan en cuenta que en caso de un incendio pueden desprenderse del producto agentes venenosos (gases, líquidos etc.) que pueden generar daños a la salud.
29. El producto puede poseer un peso elevado. Muévelo con cuidado para evitar lesiones en la espalda u otras partes corporales.
30. No sitúe el producto encima de superficies, vehículos, estantes o mesas, que por sus características de peso o de estabilidad no sean aptas para él. Siga siempre las instrucciones de instalación del fabricante cuando instale y asegure el producto en objetos o estructuras (por ejemplo paredes y estantes).
31. Las asas instaladas en los productos sirven solamente de ayuda para el manejo que solamente está previsto para personas. Por eso no está permitido utilizar las asas para la sujeción en o sobre medios de transporte como por ejemplo grúas, carretillas elevadoras de horquilla, carros etc. El usuario es responsable de que los productos sean sujetados de forma segura a los medios de transporte y de que las prescripciones de seguridad del fabricante de los medios de transporte sean tenidas en cuenta. En caso de que no se tengan en cuenta pueden causarse daños en personas y objetos.
32. Si llega a utilizar el producto dentro de un vehículo, queda en la responsabilidad absoluta del conductor que conducir el vehículo de manera segura. Asegure el producto dentro del vehículo debidamente para evitar en caso de un accidente las lesiones u otra clase de daños. No utilice nunca el producto dentro de un vehículo en movimiento si esto pudiera distraer al conductor. Siempre queda en la responsabilidad absoluta del conductor la seguridad del vehículo. El fabricante no asumirá ninguna clase de responsabilidad por accidentes o colisiones.
33. Dado el caso de que esté integrado un producto de laser en un producto R&S (por ejemplo CD/DVD-ROM) no utilice otras instalaciones o funciones que las descritas en la documentación de producto. De otra manera pondrá en peligro su salud, ya que el rayo laser puede dañar irreversiblemente sus ojos. Nunca trate de descomponer estos productos. Nunca mire dentro del rayo laser.

Contents

1 Safety directions	1.1
2 Brief introduction	2.1
Introduction.....	2.1
Block diagram	2.2
3 Preparation	3.1
Unpack the device.....	3.1
Set up the device.....	3.1
Protective grounding	3.2
Mains connection.....	3.3
Operation with non-standardized voltages.....	3.4
Reference ground	3.5
Connecting the equipment under test.....	3.6
Connecting the test receiver.....	3.6
Measurement setup.....	3.7
Sample measurement	3.9
4 Operation	4.1
Elements of the front panel	4.1
1 EQUIPMENT UNDER TEST	4.1
2 STATUS	4.2
3 RF OUTPUT	4.3
4 ARTIFICIAL HAND	4.3
Elements of the rear panel	4.4
1 REMOTE	4.4
2 Mains connection.....	4.4
3 Reference ground rail	4.5
4 Grounding conductor connection.....	4.5
5 EXTERNAL POWER SUPPLY.....	4.5
5 Remote control	5.1
Replacement circuit diagram for the remote control port.....	5.2
Pin assignment: Remote port.....	5.2
6 Servicing	6.1
Device safety inspection.....	6.1
Visual inspection.....	6.1
Test of the PE grounding connection	6.1
Measuring the Protective earth conductor's resistance.....	6.2
Surface cleaning	6.3
Storage and packaging	6.3

1 Safety directions



Note

Since the standard-compliant configuration required by CISPR 16 and VDE 0876 means that it is not possible to limit the leakage current to the value permitted by EN61010-1, and the base insulation required for a category I protection device cannot be assured, it is imperative to provide additional measures safeguarding against direct or indirect contact by the user.

The operator is responsible for ensuring that protection in accordance with VDE0100 Part 410 and VDE0876 Part 1 is maintained during work with the line impedance stabilization network. Before using for the first time, a secure connection must be made to the location's grounding conductor. This connection must satisfy the requirements for a grounding conductor connection in every detail. It must not be removed until after the network has been disconnected from the mains power supply.

If the "fuse disconnecter" protection method is used, a qualified electrical engineer must indicate the points where grounding or a connection to the location's grounding conductor may be sited.

The safety notes in the accompanying operating instructions and on the outside of the device must be followed at all times.



Caution!

Before using for the first time, the network must be connected to an additional conductor that is compliant with VDE0100.

Users must be aware that it is possible for socket connections and grounding conductors to become disconnected. A further grounding conductor with adequate cross-section must be connected between a grounding conductor connection for the measurement area and the grounding conductor connection (grounding bolt) on the back panel of the ENV216.

Only then may the network be connected to the mains power supply.

At shutdown, the same procedure must be followed in the reverse order:

First the network must be disconnected from the mains power supply, and only then should the additional grounding conductor connection be removed.

2 Brief introduction

Introduction

The ENV216 compact Two Line V-Network is used to measure noise voltage on mains-dependent consumers.

Its principal tasks are:

- To supply the equipment under test with mains voltage
- To provide a standardized load impedance
- Defined transmission of the noise voltage generated by the equipment under test to the EMI test receiver
- Isolation of the test circuit from interference of the power source.

The ENV216 Two Line V Network is constructed using air-core inductances (50 μH and 250 μH) and conforms with the recommendations of VDE0876 and CISPR 16-1.

Other features of the equipment include:

- Artificial Hand
- 10-dB-attenuator in the RF path
- Switchable 150-kHz-highpass filter
- Pulse voltage limiter at the measurement output
- Remote control port
- External power supply via plugged power pack for tests on non-standardized a.c and d.c. voltages

The network may be operated manually or by remote control with TTL levels.

Block diagram

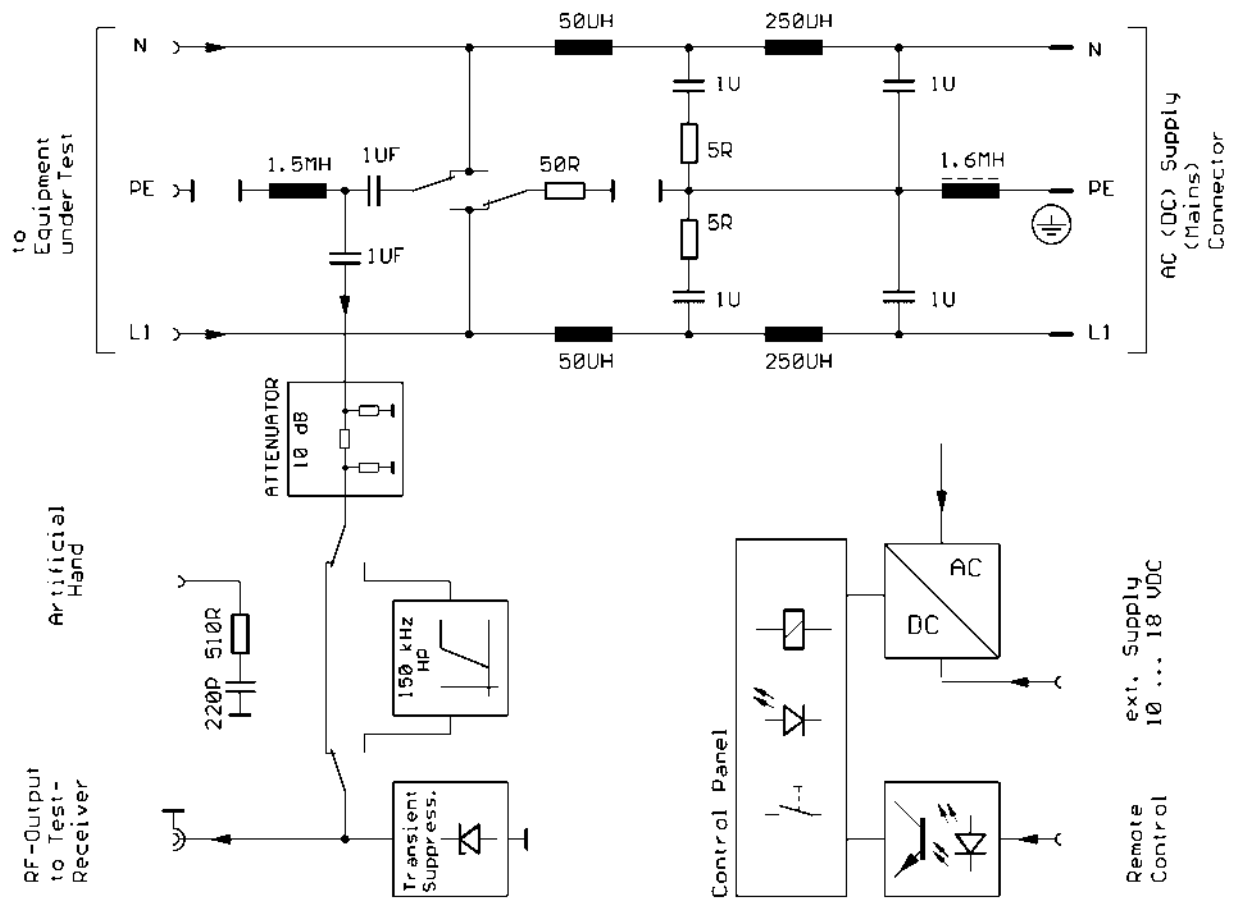

3 Preparation

Unpack the device

Remove the two protective hoods from the front and rear and inspect the device carefully for any damage.

If the device is damaged, you should notify the responsible freight carrier immediately and retain all items of packaging in order to support your complaint. The original packaging is also useful for use when shipping or transporting at a later date. You should at least keep the two protective hoods for the front and rear, to protect against damage to the control elements and connections.

Set up the device

Before starting the ENV216 for the first time, ensure that

- a PE conductor is connected,
- the ventilation openings are unobstructed,
- no signal or operating voltages above the permissible limits are present at the inputs,
- the device's outputs are not overloaded or incorrectly connected.

Failure to comply with any of these points may damage the equipment.



Caution!

Note the instruction regarding protective grounding in chapter 3, section entitled Protective grounding!



Warning!

The flow of air from above and below must be unimpeded at all times while the ENV216 is in use.

As the device is equipped with ventilation apertures on its underside, it must not be left to run unsupervised or it must be set up on a non-flammable surface (e.g. metal plate, marble slab) to avoid fire in the event of overheating.

Protective grounding



Warning!

Operating the device without protective earth may cause serious injury or death. The direction in chapter 1 entitled "Safety direction" must be followed without exception!



Caution!

Before using for the first time, the network must be connected to an additional conductor that is compliant with VDE0100.

Users must be aware that it is possible for socket connections and grounding conductors to become disconnected. A further grounding conductor with adequate diameter must be connected between a grounding conductor connection for the measurement area and the grounding bolt (1) on the ENV216.

Only then may the network be connected to the mains power supply.

At shutdown, the same procedure must be followed in the reverse order:

First the ENV216 must be disconnected from the mains power supply, and only then should the additional grounding conductor connection be removed.

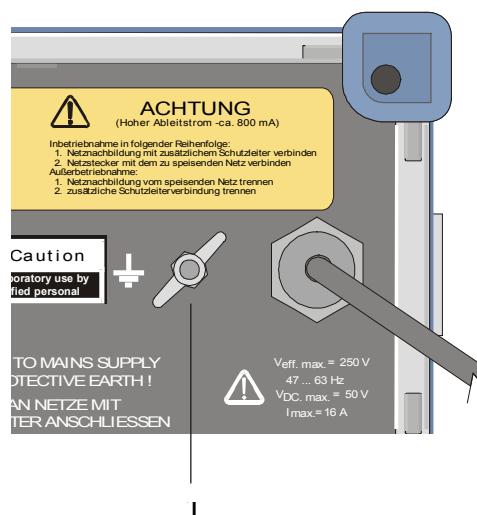

Threaded bolt with butterfly nut on the rear of the device

Mains connection

Connection to the mains power supply is provided by a permanently attached mains cable. The device is not equipped with an ON / OFF switch.

**Caution!**

When beginning operation, the sequence below must be followed strictly:

*Connect network to auxiliary protective grounding
Connect mains plug to the mains power supply*

Switching off:

*Unplug network from the mains power supply
Disconnect auxiliary grounding connection*

**Caution!**

*Due to the high level of earth leakage current, the device cannot be operated on power supplies protected by residual current devices (RCDs).
The power source must be protected by a circuit breaker with a maximum rating of 16 A characteristic B or C.*

If the phase connection is made correctly, LED L1 (1) must light up.
If it does not:

- Ø For mains plugs with symmetrical grounding connection (e.g. Schuko plugs) the plug's polarity must be reversed.
- Ø For mains plugs with asymmetrical grounding connection, phase L1 and neutral N must be swapped by reconnecting.

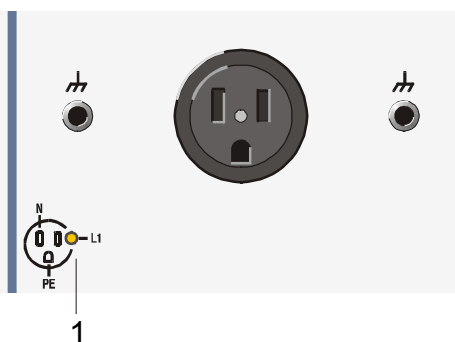

L1 LED, phase indicator

The plug on the mains cable can be adapted using a country-specific adapter. However, it must be ensured that the adapter has a power rating of at least 16 A. Assembly must be carried out exclusively by qualified technicians.

Operation with non-standardized voltages

For measurement tasks on voltages that are outside the normal mains voltage ranges (e.g. <100 VAC) and for operation on d.c. (max. 50 VDC) the ENV216 control circuit is powered externally by a plug-in power supply.



Caution!

The d.c. voltage must not exceed 50 VDC!

The plug-in power supply is connected to the "EXT. POWER SUPPLY" socket (13). The input is reverse voltage protected.

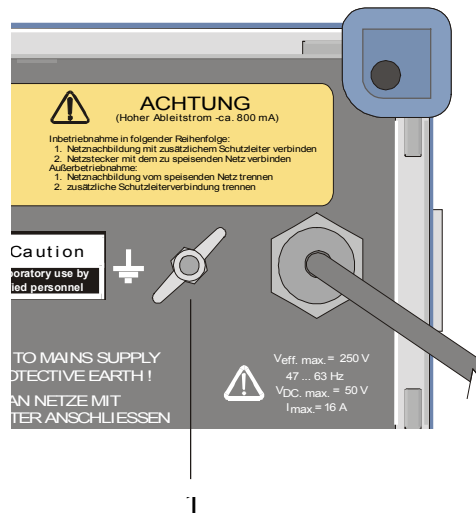

EXT POWER SUPPLY socket

Caution!



When external power supplies are used to power the device with the auxiliary DC voltage (SELV) the requirements for reinforced/double insulation in accordance with DIN/EN/IEC 61010 (UL 3111, CSA C22.2 No. 1010.1) or DIN/EN/IEC 60950 (UL 1950, CSA C22.2 No. 950) must be satisfied.

Reference ground

The network is connected to the PE grounding connection for the mains power supply through the mains cable, but this is not adequate for use as a reference ground in HF noise voltage measurement.

The reference ground used can be attached flat to the grounding rail (2) on the side of the device by a broad sheet metal with three metric M4 screws (1).

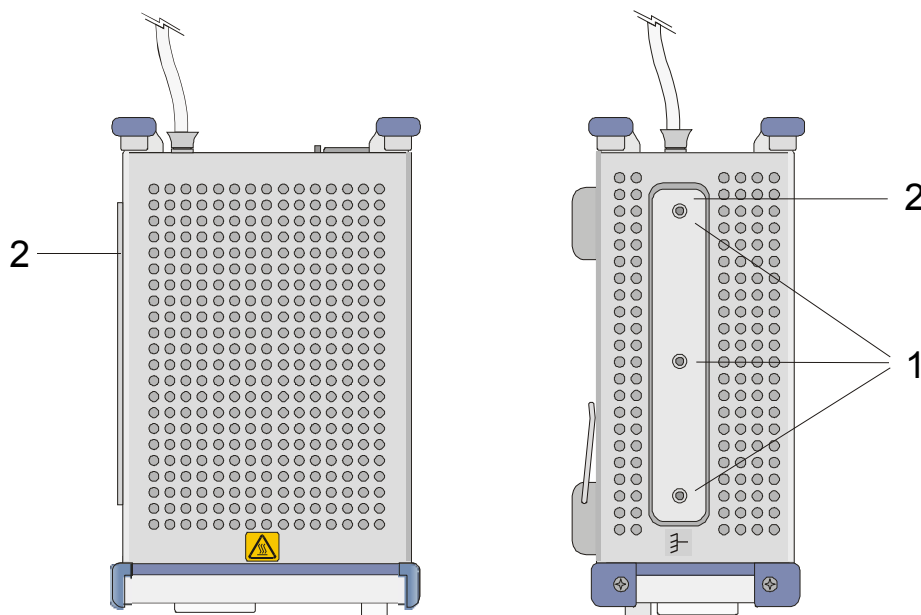

Grounding rail on the side of housing

In order to prevent RF interference emitted by the mains grounding conductor from reaching the reference mass, the grounding conductor and the reference mass are decoupled by a PE-choke. This choke should not be bridged by the EMI test receiver, which is also connected to the measurement reference ground. Therefore, either an isolated or a battery-powered receiver must be used, or a PE choke must also be placed on the PE connection of the receiver.

Connecting the equipment under test

The equipment under test is connected via the socket (1) on the front of the ENV216. Constant current must not exceed 16 A. For ambient temperatures $>35^{\circ}\text{C}$, external air ventilation is recommended.

The RFI voltage measurement plane is located on the front panel of the ENV216. The impedance gradient of connections N and L1 of the socket is measured against the reference ground connectors (4-mm-jacks) to the left and right (2) of the socket (1).

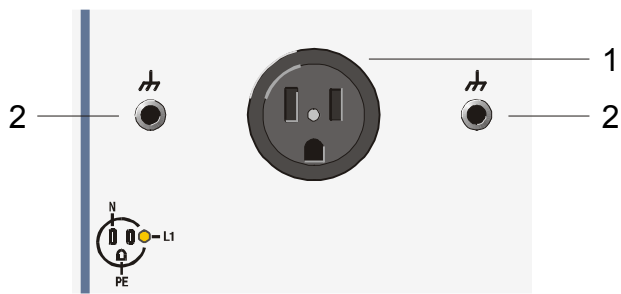

Connecting the test receiver

The test receiver is connected to the N connector RF OUTPUT (1) by a 50- Ω -coaxial cable.

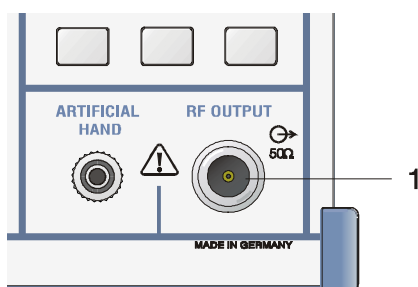

Measurement setup

The ENV216 Two-Line V-Network satisfies the requirements of interference measurement regulations VDE 0876, CISPR 16-1, and the U.S. FCC (Rules and Regulations Part 15J).

The measurement setups prescribed in the individual standards are largely similar. VDE regulation 0877 provides a detailed description.

Devices under test that are not equipped with permanently attached connecting wires are connected to the network using a 1 meter long, unshielded wire. For devices under test equipped with a permanently attached cable that is longer than 1 meter, the cable is laid out in a folded configuration.

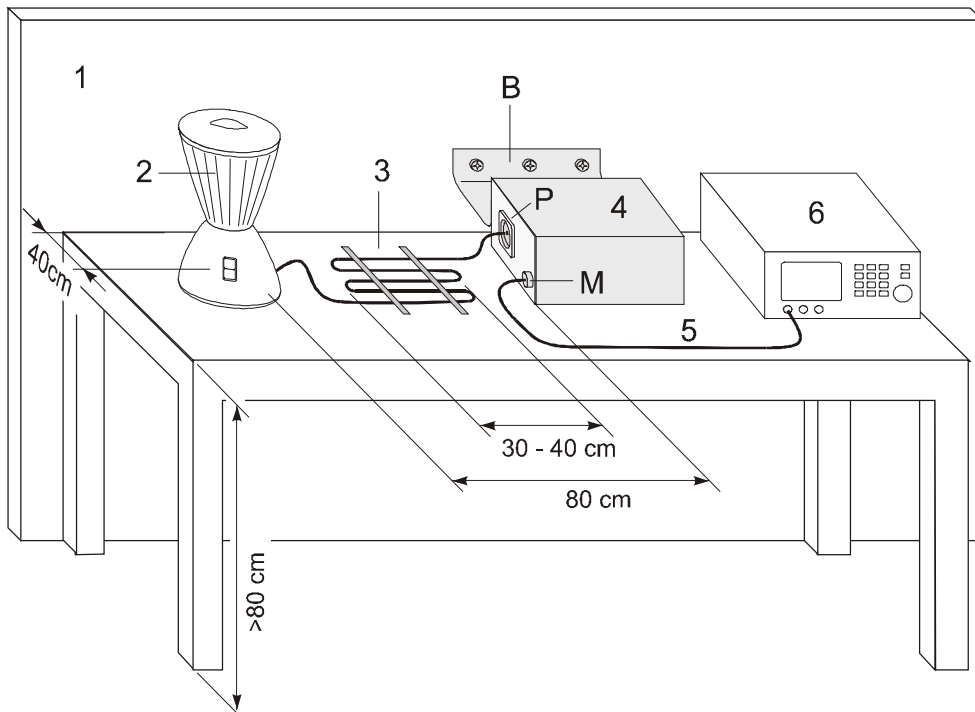

Item	Description
1	Metal wall, at least 2 m x 2 m
2	Equipment under test
3	Cable in folded configuration
4	Two-Line V-Network
5	Shielded connection cable
6	Test receiver
B	Reference ground connection
M	Test receiver connector
P	Test device connector

Devices under test that have a separate ground connection and are not connected by integral grounding conductors are grounded using an additional connection cable. This is inserted into the ground connector (1) to the right of the test device socket and runs parallel to the mains cable.

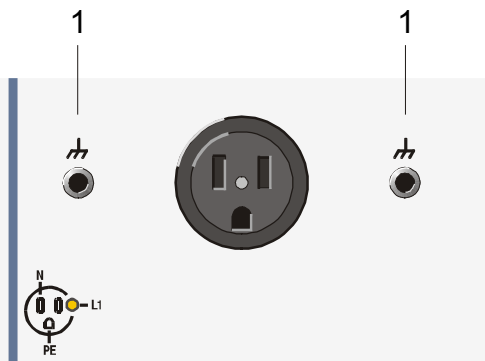

RF- ground connectors

When measuring devices that are held in the hand during operation (e.g. electric drills), the effect of the human hand is simulated by connecting to the "Artificial Hand" hand simulation jack.

The hand simulation consists of the connection in series of a 220-pF-capacitor with a 510-Ω-resistor. The connection is located in the front panel of the ENV216.

If the housing of the equipment under test is made entirely of metal, the "Artificial Hand" jack is connected to the housing the equipment under test.

If the housing is made from non-conductive material, metal foils are wound round the handles and a 60 mm wide foil is wound round the point on the housing that can also be gripped by the hand. All foils are connected together and with the "Artificial Hand" jack.

The figure in chapter 3, section entitled "Sample measurement" on the following page illustrates an example of how the foils are applied.

Sample measurement

The figure shows the measurement setup for measuring the RFI voltage of a handheld drill. In this example, the handheld drill is connected to three metal foils.

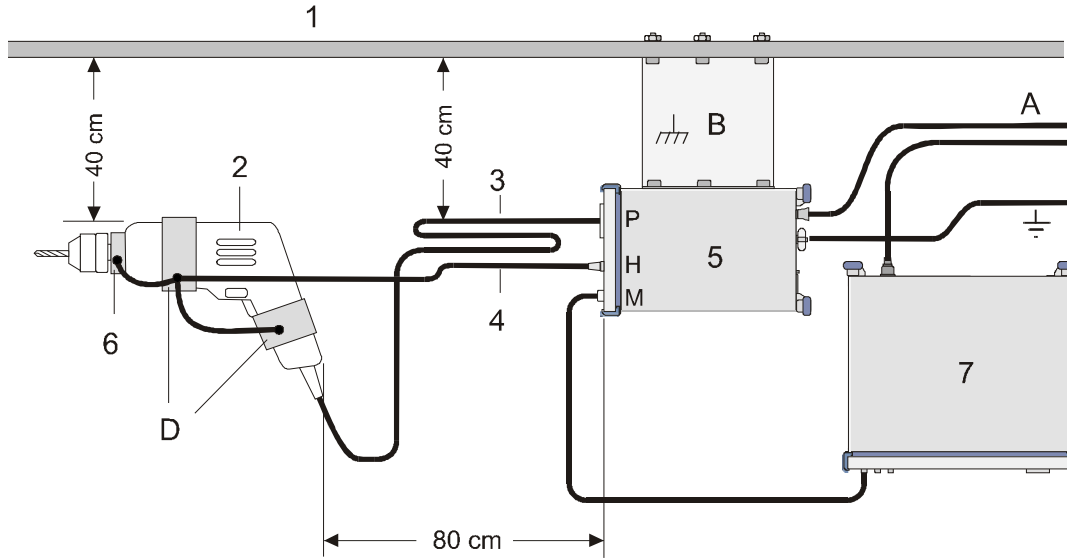

Item	Description
1	Metal wall, at least 2 m x 2 m
2	Equipment under test
3	Connection cable
4	Connection cable running separately to the hand simulation
5	Two-Line V-Network
6	Metallic collar capable being gripped
7	Test receiver
A	Power supply connection
B	Reference ground connection, low-inductance (e.g. brass plate, 0.2 m)
P	Test device connector
H	Artificial Hand connector
M	Test receiver connector
D	Metal foils

4 Operation

Elements of the front panel

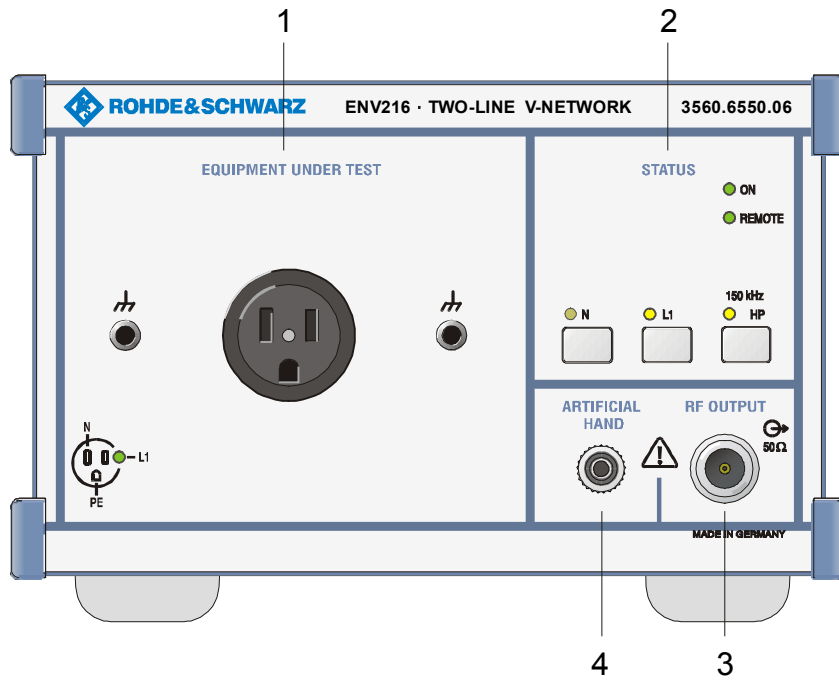

1 EQUIPMENT UNDER TEST

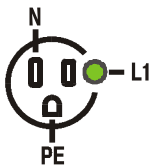

L1 INDICATOR

Illustration showing the correct assignment of L1 and N to the measurement channels. LED "L1" lights up if the polarity of the mains plug is correct. (see also chapter 3 "mains connection")

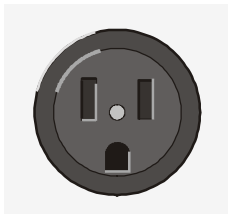

EUT socket

socket for connecting the equipment under test



Reference ground
(RF- ground)

4-mm-jacks for connecting to the equipment under test (see also "Measurement setup" in chapter 3)

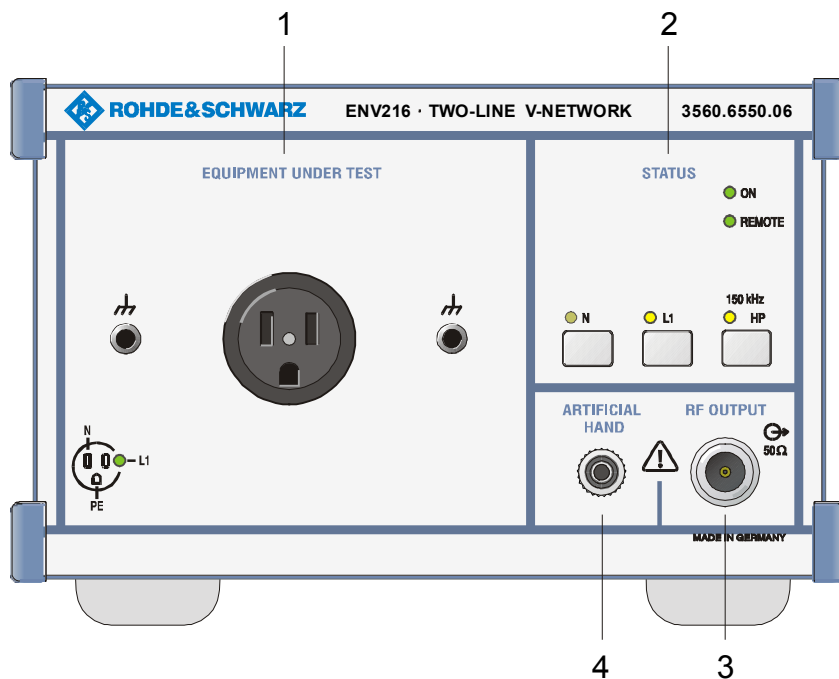

2 STATUS



ON

ON

This LED shows that the ENV216 is powered up.



REMOTE

REMOTE

This LED shows that a remote control function is active. (See also chapter 5 "Remote control")

This LED goes off automatically when all remote control functions are inactive or the port is not occupied.



N



L1

L1, N



The measurement path is selected manually using the "L1" and "N" keys. When either key is pressed, it releases the other. They are both locked when the REMOTE LED is lit. The associated LEDs always indicate the active path, even when this has been selected using the remote control. (See also chapter 5 "Remote control")

150 kHz



HP

150 kHz HP



With this toggle key a 150 kHz highpass filter can be switched into the measurement path. This enables interference voltages in the low-frequency range, e.g. from switch-mode power supplies, to be suppressed. The associated LED lights up when the filter is active. This key is locked when the "REMOTE" LED is lit. (See also chapter 5 "Remote control")

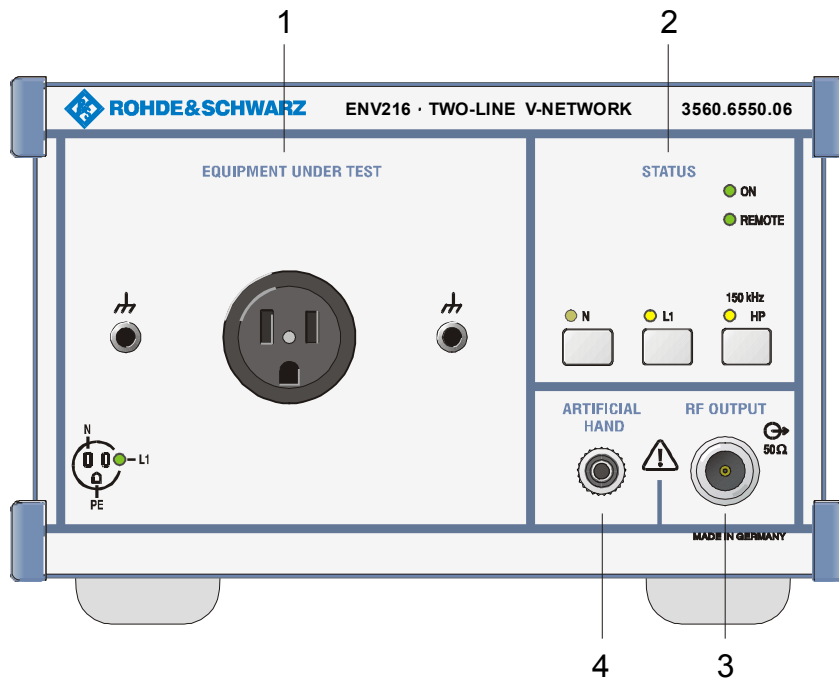

3 RF OUTPUT

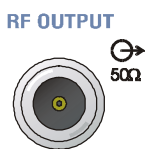

RF OUTPUT

The "RF OUTPUT" socket is the RFI voltage measurement output for connecting the test receiver. The RFI voltage spectrum of the selected path is attenuated at the "RF OUTPUT" by 10 dB. The 10-dB-attenuator and a transient suppressor are permanently inserted. A 150-kHz-highpass filter can additionally be switched into the path either manually or by remote control. The socket is an "N" type. The output impedance is 50 Ω.

4 ARTIFICIAL HAND



ARTIFICIAL HAND

The "ARTIFICIAL HAND" enables the effects of the human hand to be simulated. Metal housing parts of the equipment under test that are usually touched with the hand can be connected to this jack. The hand simulation consists of connection in series of a 510-Ω-resistor and a 220-pF-capacitor. The jack is a 4-mm-terminal clamp.

(For more information, see also "Sample measurement" in chapter 3)

Elements of the rear panel

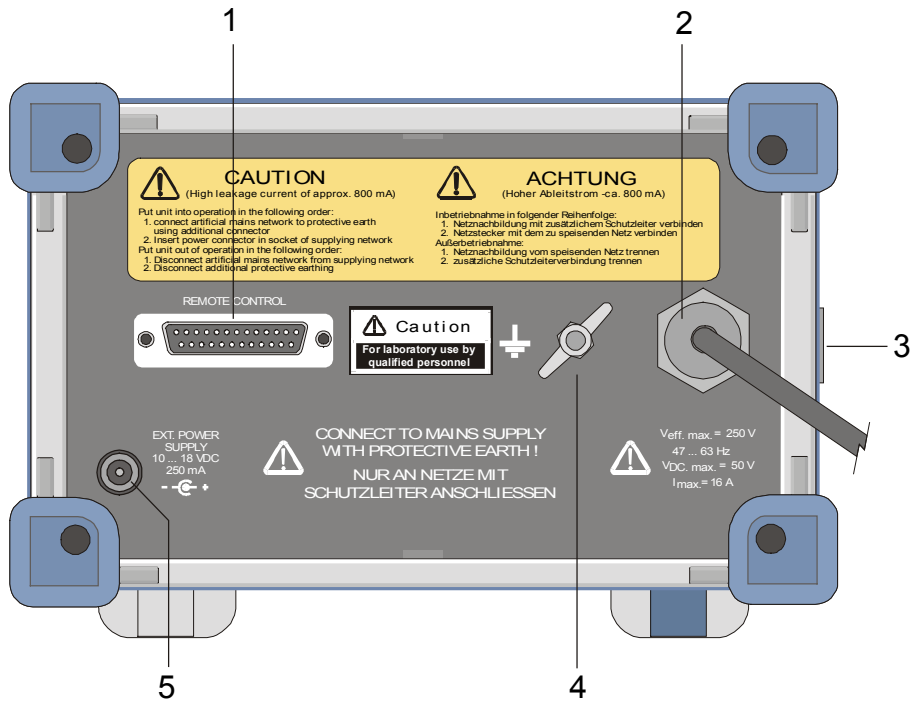

1 REMOTE

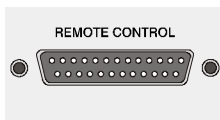

REMOTE

Remote control port. This connection is used to enable remote control of measurement path "L1" or "N" and the "150 kHz HP" integral filter. (For more information See also chapter 5 "Remote control")

2 Mains connection

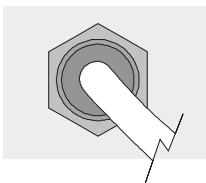

Mains connection cable

The mains connection cable is primarily used to supply power to the equipment under test.

When voltages under about 100 VAC are connected, and for all d.c. voltages, the auxiliary voltage for the ENV control circuit must be supplied externally by the plug-in power supply included with the device.



Caution!

The instructions in chapter 3 "Preparation" must be followed at all times.

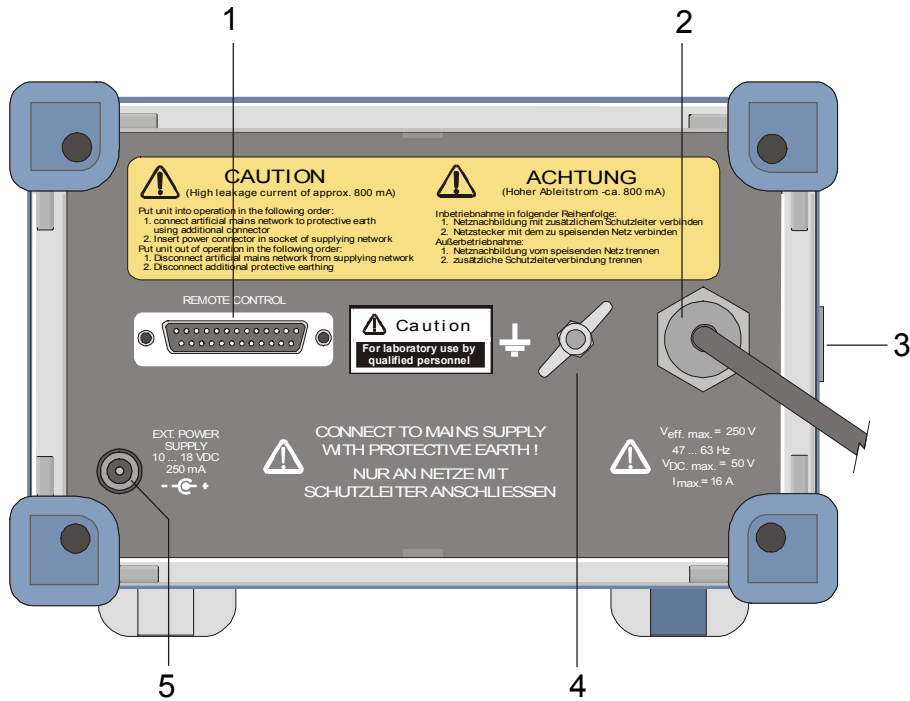

3 Reference ground rail

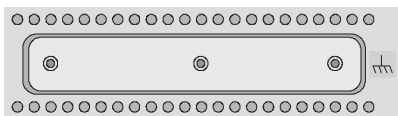

ground rail

The ground rail that is included on the side of the device is used exclusively for connecting a reference ground. A broad metal foil can be placed over it to create a low-inductance connection with the test setup.

4 Grounding conductor connection



Grounding conductor connection



The connection, a 6-mm-threaded bolt with butterfly nut is used only for protective grounding. It is not suitable for use as a reference ground.

Caution!

The instructions in chapter 1 "Safety directions" and chapter 3 "Preparation" must be followed at all times

5 EXTERNAL POWER SUPPLY

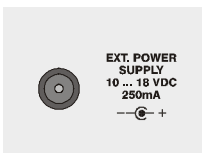

External Power Supply

Connection for the plug-in power supply. The control circuitry of the ENV216 is powered via the "EXTERNAL POWER SUPPLY" connection, if the ENV216 is to be used to conduct measurements of a.c. voltages below 100 VAC or on d.c. voltages up to 50 VDC. (for more information see also chapter 3, section entitled "Operating with non-standardized voltages")

5 Remote control

The functions L1, N and 150 kHz HP can be controlled remotely by applying a static LOW level to the appropriate contact of the SUB-D25 female connector (1) on the rear of the ENV216.

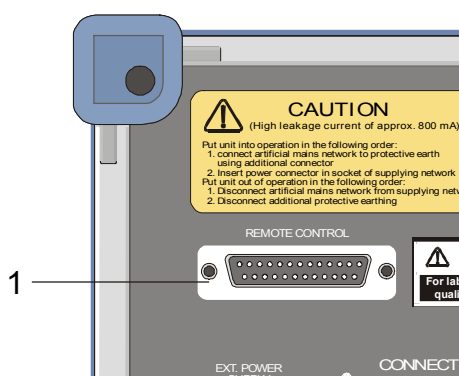

As soon as a LOW signal is detected at input L1, N or 150 kHz HP, the corresponding function is activated and manual operation is blocked at the same time. The functions that have been switched on are indicated by the associated LEDs. When remote control is active, the REMOTE LED is lit.

When the LOW signal is removed, manual operation is enabled again and the status set manually prior to the remote operation is restored.

The settings are not saved if the device is disconnected from mains supply; instead, the default status (L1 "ON" and 150 kHz HP "OFF") is always restored when mains power is switched on.

Note *The ENV216 is configured for direct connection to ROHDE&SCHWARZ test receivers.*

If remote control is performed via an R&S receiver, the REMOTE LED is lit when the ESH3-Z5 type network is selected. The user can choose between "N" and "L1". The 150-kHz-highpass filter can be inserted into the signal path by pressing the "Floating" key on the receiver..

Replacement circuit diagram for the remote control port

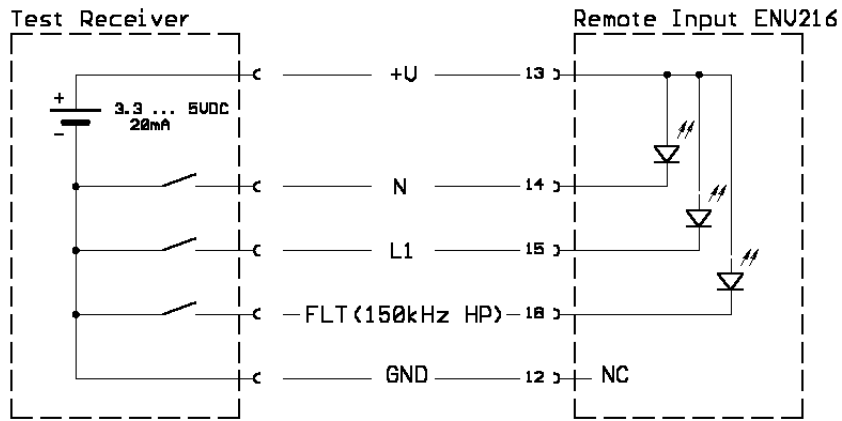

Pin assignment: Remote port

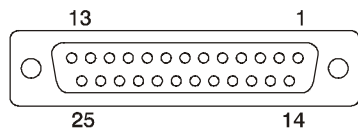

SUB-D 25
female

Description	25 pin RS232
TTL (+5V)	13
N	14
L1	15
FLT	18
GND	12

6 Servicing

The device does not need to be regularly serviced. Servicing is limited essentially to wiping the device's external surfaces.

However, it is recommended to check the rated specifications from time to time.

Device safety inspection

A device safety inspection of the network as defined in BGV A2 is not possible because of the required, standard-compliant configuration according to CISPR 16 and VDE 0876. Therefore, the following examinations must be carried out as a minimum requirement.

Visual inspection

It should be ensured that parts relevant for active and passive safety are not visibly damaged or even unsuitable for use in the device. In particular, a check should be made to determine whether safety-critical parts may have been rendered unfit to meet the requirement to which they are subject as a result of the use to which the device has been put (effects extended use, environmental influences).

The following must not be damaged:

- Housing, displays, carrying handles, air vents
- Device connection cables, connection points and mains lead cleats
- Mains plug, fuse holder
- Labeling and markings, warning notices
- Isolated parts, wiring insulation
- Plug connections and clamping points
- Vent and leakage paths must not be altered unacceptably.

The firmness of the connections must be tested by tugging them briefly by hand.

A check must also be made to confirm that the fuses used match the nominal ratings indicated in the documentation.

Test of the PE grounding connection

This test is intended to determine whether the resistance between contactable parts, which must be securely grounded for safety reasons, and the grounding contact of the mains connector **is less than 0.3 W**.

During the measurement, the entire length of the wire is to be moved in sections. If a change in resistance is noted while part of the wire is being moved, the fault must be found with a detailed troubleshooting procedure. Defective cables must not be repaired. They must be replaced in all cases.

Measuring the Protective earth conductor's resistance

The resistans of the PE connection must be checked by a measurement according to fig. 1. The test current is set to 10 A_{DC}.

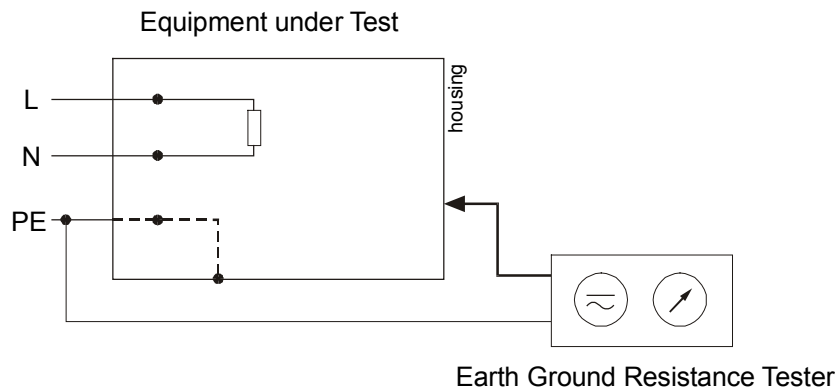
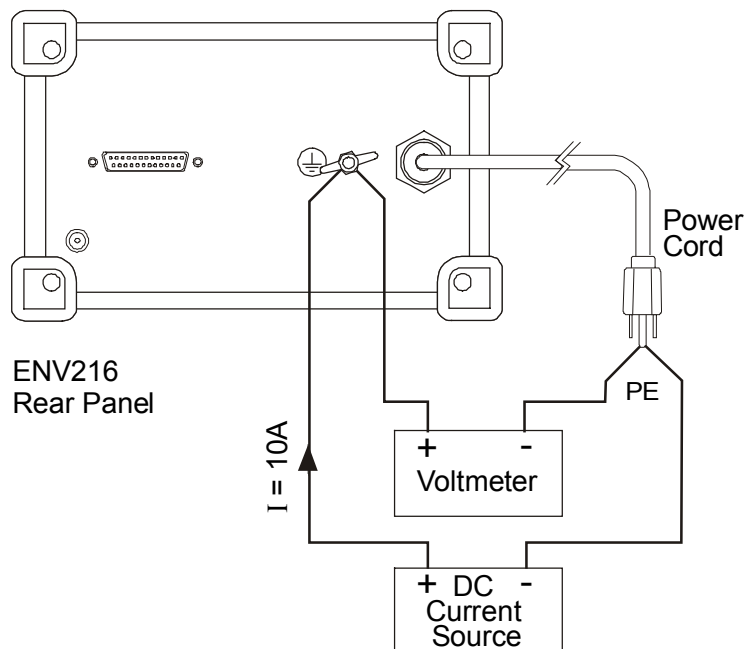

Fig 1.: Measuring the resistance of the PE connection with device disconnected from the mains.

In addition to the usual points, measurements should also be taken from the PE contact of the mains plug to the bolt on the rear panel of the ENV216.



The resistance of the PE connection is calculated from the voltage reading divided by the supplied current.

Surface cleaning

Cleaning the outside surfaces of the device is best performed with a soft, lint-free cloth.

Caution! *Never use solvents such as nitro solvent, acetone or similar, as this will degrade the labeling on the front panel and may also damage the plastic parts.*

Storage and packaging

The device should be stored at a temperature between -25 and $+70$ °C. During extended periods of storage, protect the device from dust accumulation.

The original packaging, and particularly the covering for the front and rear panels, should be used if the device is transported or shipped again. If the original packaging is no longer available, the device should be packed carefully to prevent mechanical damage and packed tightly into a solid box of appropriate size.