



Agilent 8494/95/96G/H Attenuators

Operating and Service Manual



Agilent Technologies

Notices

© Agilent Technologies, Inc. 2011-2012

No part of this manual may be reproduced in any form or by any means (including electronic storage and retrieval or translation into a foreign language) without prior agreement and written consent from Agilent Technologies, Inc. as governed by United States and international copyright laws.

Manual Part Number

08495-90025

Edition

Fourth Edition, March 2012

Printed in Malaysia

Agilent Technologies, Inc.

Phase 3 Bayan Lepas Free Industrial Zone
Bayan Lepas, Penang 11900 Malaysia

Warranty

The material contained in this document is provided “as is,” and is subject to being changed, without notice, in future editions. Further, to the maximum extent permitted by applicable law, Agilent disclaims all warranties, either express or implied, with regard to this manual and any information contained herein, including but not limited to the implied warranties of merchantability and fitness for a particular purpose. Agilent shall not be liable for errors or for incidental or consequential damages in connection with the furnishing, use, or performance of this document or of any information contained herein. Should Agilent and the user have a separate written agreement with warranty terms covering the material in this document that conflict with these terms, the warranty terms in the separate agreement shall control.

Technology Licenses

The hardware and/or software described in this document are furnished under a license and may be used or copied only in accordance with the terms of such license.

Restricted Rights Legend

U.S. Government Restricted Rights. Software and technical data rights granted to the federal government include only those rights customarily provided to end user customers. Agilent provides this customary commercial license in Software and technical data pursuant to FAR 12.211 (Technical Data) and 12.212 (Computer Software) and, for the Department of Defense, DFARS 252.227-7015 (Technical Data - Commercial Items) and DFARS 227.7202-3 (Rights in Commercial Computer Software or Computer Software Documentation).

Safety Notices

CAUTION

A **CAUTION** notice denotes a hazard. It calls attention to an operating procedure, practice, or the likes of that, if not correctly performed or adhered to, could result in damage to the product or loss of important data. Do not proceed beyond a **CAUTION** notice until the indicated conditions are fully understood and met.

WARNING

A **WARNING** notice denotes a hazard. It calls attention to an operating procedure, practice, or the likes of that, if not correctly performed or adhered to, could result in personal injury or death. Do not proceed beyond a **WARNING** notice until the indicated conditions are fully understood and met.

Certification

Agilent Technologies certifies that this product met its published specifications at the time of shipment from the factory. Agilent Technologies further certifies that its calibration measurements are traceable to the United States National Institute of Standards and Technology (NIST, formerly NBS), to the extent allowed by the Institute's calibration facility, and to the calibration facilities of the other International Standards Organization members.

WEEE Compliance





This product complies with the WEEE Directive (2002/96/EC) marking requirements. The affixed label indicates that you must not discard this electrical/electronic product in domestic household waste.

Product Category: With reference to the equipment types in the WEEE Directive Annex I, this product is classed as a "Monitoring and Control Instrumentation" product.

Do not dispose in domestic household waste.

To return unwanted products, contact your local Agilent office, or see www.agilent.com for more information.

Regulatory Markings

	The CE mark is a registered trademark of the European Community. If it is accompanied by a year, it indicates the year the design was proven.
	The CSA mark is a registered trademark of the Canadian Standards Association.
ICES/NMB-001	This text indicates that this ISM device complies with Canadian ICES-001. Cet appareil ISM est conforme a la norme NMB-001 du Canada.
ISM 1-A	This text indicates that the instrument is an Industrial Scientific and Medical Group 1 Class A product (CISPER 11, Clause 4).
	This symbol indicates the time period during which no hazardous or toxic substance elements are expected to leak or deteriorate during normal use. Forty years is the expected useful life of the product.

Contacting Agilent

For more information, please contact your nearest Agilent office.

Americas

Canada	(877) 894-4414
Latin America	305 269 7500
United States	(800) 829-4444

Asia Pacific

Australia	1 800 629 485
China	800 810 0189
Hong Kong	800 938 693
India	1 800 112 929
Japan	81 426 56 7832
Korea	080 769 0800
Malaysia	1 800 888 848
Singapore	1 800 375 8100
Taiwan	0800 047 866
Thailand	1 800 226 008

Europe

Austria	0820 87 44 11
Belgium	32 (0) 2 404 93 40
Denmark	45 70 13 15 15
Finland	358 (0) 10 855 2100
France	0825 010 700
Germany	01805 24 6333
Ireland	1890 924 204
Italy	39 02 92 60 8484
Netherlands	31 (0) 20 547 2111
Spain	34 (91) 631 3300
Sweden	0200-88 22 55
Switzerland(French)	41 (21) 8113811 (Opt 2)
Switzerland(German)	0800 80 53 53 (Opt 1)
United Kingdom	44 (0) 118 9276201
Other European Countries:	www.agilent.com/find/contactus

Or, go to www.agilent.com/find/assist for more information.

This page is intentionally left blank.

Contents

1	Introduction	9
	Product Overview	10
	Instrument Options	14
	Specifications	15
	Frequency Range and Attenuation	15
	Attenuation Accuracy	16
	Maximum SWR	17
	Maximum Residual Attenuation	17
	Attenuation Repeatability	17
	RF Power Handling Capability	18
	Solenoid Drive	18
	Solenoid Cable Connector	19
	Operating Life	20
	Switching Speed	20
2	Environmental Specifications & Physical Dimensions	21
	Environmental Specifications	22
	Physical Dimensions	23
3	Operating Guides	25
	Installation	26
	Initial Inspection	26
	Mating Connectors	27
	Installation Instructions	27
	Operating Instructions	28
	Operator's Check	28
	Performance Tests	31
	Service Instructions	31

This page is intentionally left blank.



1 Introduction

Product Overview	10
Instrument Options	14
Specifications	15
Frequency Range and Attenuation	15
Attenuation Accuracy	16
Maximum SWR	17
Maximum Residual Attenuation	17
Attenuation Repeatability	17
RF Power Handling Capability	18
Solenoid Drive	18
Solenoid Cable Connector	19
Operating Life	20
Switching Speed	20

This manual contains operating instructions for the Agilent 8494/95/96G/H Attenuators. Included in the manual is information required to install and test these attenuators.



Product Overview

The 8494G/H, 8495G/H, and 8496G/H are 50-ohm coaxial programmable step-attenuators. Each attenuator is composed of three or four attenuator sections connected in cascade. Each section consists of a precision, thin-film attenuator card, a lossless thru-line, and a ganged pair of solenoid-actuated slab line transmission lines. The slab lines are flexed by the solenoid plungers to make contact with either the attenuator card or the thru-line. The slab line contacts are gold plated leaf springs which ensure long life and extremely high repeatability.

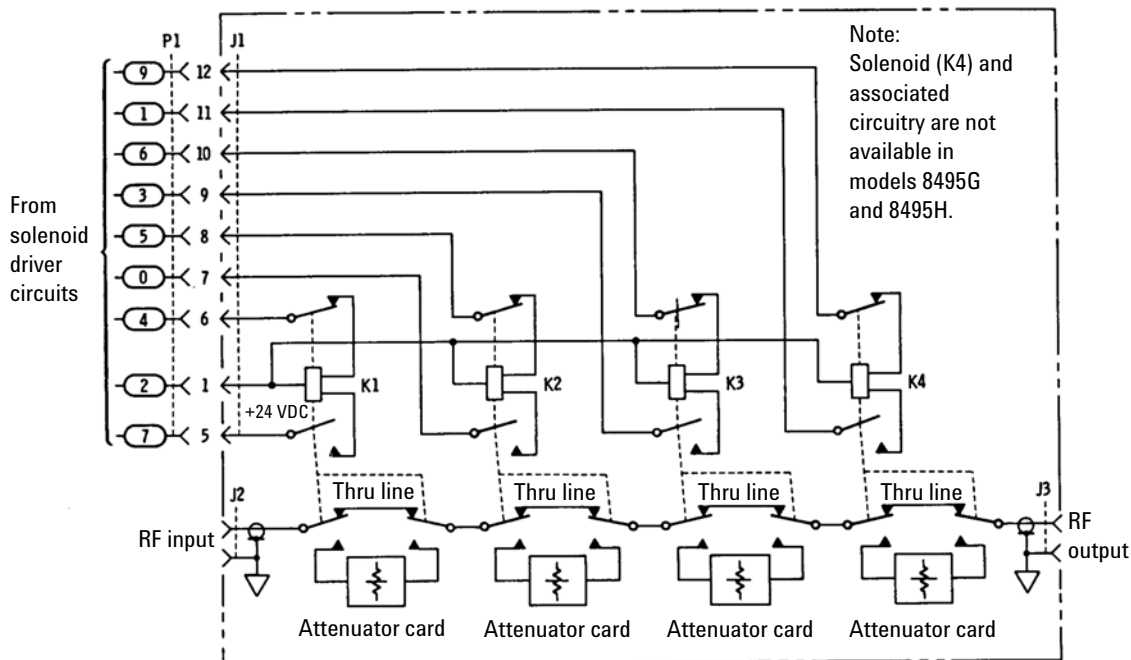

Figure 1 Typical Four-Section Attenuator Schematic Diagram

Table 1 on page 11, Table 2 on page 12, and Table 3 on page 12 show the typical switching arrangement to increase the amount of attenuation in an 8494G/H, 8495G/H, or 8496G/H in a linear manner. To ensure specified performance, it is recommended that the attenuator sections that are shown in the following tables be used. With the attenuator programmed for 0 dB attenuation, the resultant attenuation is the insertion loss (residual attenuation). The 8494G/H has a minimum selectable step of 1 dB, while the 8495G/H and 8496G/H have a minimum selectable step of 10 dB. The accuracy of the attenuators is within the limits given in “Specifications” on page 15.

- The 8494G/H are four-section attenuators with a maximum attenuation of 11 dB.
- The 8495G/H are three-section attenuators with a maximum attenuation of 70 dB.
- The 8496G/H are four-section attenuators with a maximum attenuation of 110 dB.

Table 1 8494G/H Attenuator Switching Order

8494G/H Attenuator Sections				
Atten (dB)	1 1 dB	2 2 dB	3 4 dB	4 4 dB
0				
1	×			
2		×		
3	×	×		
4			×	
5	×		×	
6		×	×	
7	×	×	×	
8			×	×
9	×		×	×
10		×	×	×
11	×	×	×	×

Table 2 8495G/H Attenuator Switching Order

8494G/H Attenuator Sections			
Atten (dB)	1 10 dB	2 20 dB	3 40 dB
0			
10	×		
20		×	
30	×	×	
40			×
50	×		×
60		×	×
70	×	×	×

Table 3 8496G/H Attenuator Switching Order

8496G/H Attenuator Sections				
Atten (dB)	1 10 dB	2 20 dB	3 40 dB	4 40 dB
0				
10	×			
20		×		
30	×	×		
40			×	
50	×		×	
60		×	×	
70	×	×	×	
80			×	×
90	×		×	×
100		×	×	×
110	×	×	×	×

Each solenoid requires a drive of 20 V to 30 V with a switching current of approximately 125 mA^[1] at 24 Vdc per section. The solenoid switching time is less than 20 milliseconds including settling time. Once switched, the solenoid plungers are held in place by permanent magnets and the solenoid plungers automatically disconnect the selected coil drive and connect the opposite coil drive (see Figure 1 and Figure 2). This simplifies the coil driver circuit design and reduces the amount of heat dissipated by the solenoid coils since the solenoid coils are energized only for the 20 milliseconds switching time.

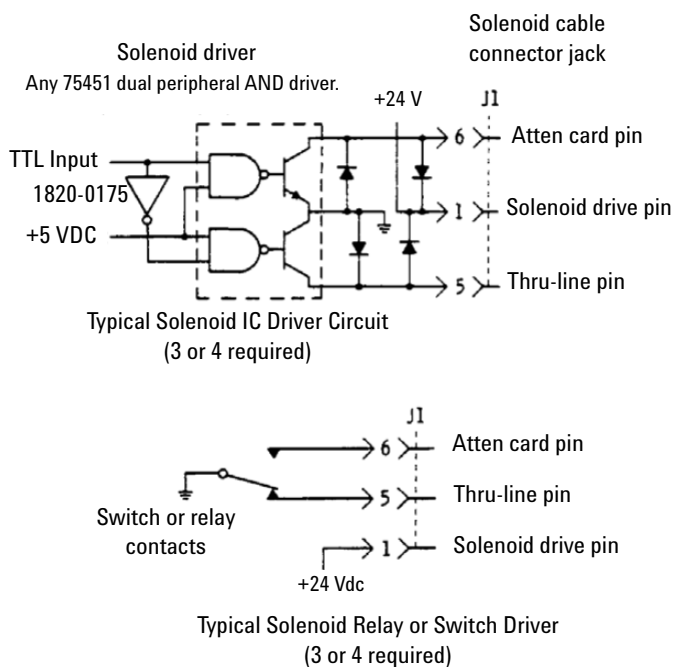

Figure 2 Typical Solenoid Coil Driver Circuits

[1] For serial number prefixes below 1722A, change 125 mA to 110 mA.

CAUTION

Do not exceed the RF power rating of 1 W average or 100 W peak with a maximum pulse width of 10 μ s. Do not connect an attenuator RF input or output connector to greater than ± 7 Vdc. If the attenuator must be connected to a device with a potential greater than ± 7 Vdc, use a blocking capacitor.

Instrument Options

Each instrument is specified with an option number which denotes the configuration of the input and output connectors.

Table 4 Instrument Options

Option	Description
001	Type-N (f) connectors
002	SMA female connectors
003 ^[1]	APC-7 connectors
024 ^[2]	24 Vdc supply voltage
011	5 V operation instead of standard 24 V
016	14-pin dip plug, 16-inch DC ribbon cable
060 ^[2]	Viking to bare wire cable

[1] Option 003 is not available on the 8495G.

[2] Option 024 and 060 are default options unless specified otherwise.

Specifications

Frequency Range and Attenuation

Table 5 Frequency Range and Attenuation

Instrument	Frequency Range	Attenuation
8494G	dc to 4 GHz	0 dB to 11 dB in 1 dB steps
8494H	dc to 18 GHz	0 dB to 11 dB in 1 dB steps
8495G	dc to 4 GHz	0 dB to 70 dB in 10 dB steps
8495H	dc to 18 GHz	0 dB to 70 dB in 10 dB steps
8496G	dc to 4 GHz	0 dB to 110 dB in 10 dB steps
8496H	dc to 18 GHz	0 dB to 110 dB in 10 dB steps

Attenuation Accuracy

(±dB): (Referenced from 0 dB)

Table 6 Attenuation Accuracy

8494G/H		8495G/H 8496G/H		8494G	8494H			8495G	8495H			8496G	8496H		
Attenuation Selection (dB)				dc–4 GHz	dc–12.4 GHz	12.4–18 GHz	dc–4 GHz	dc–12.4 GHz	12.4–18 GHz	dc–4 GHz	dc–12.4 GHz	12.4–18 GHz	dc–4 GHz	dc–12.4 GHz	12.4–18 GHz
1	10	0.2	0.3	0.2	0.3	0.7	0.2	0.5	0.6	0.2	0.5	0.6	0.2	0.5	0.6
2	20	0.2	0.3	0.2	0.3	0.7	0.4	0.7	0.8	0.4	0.7	0.8	0.4	0.7	0.8
3	30	0.3	0.4	0.3	0.4	0.7	0.5	0.9	1.2	0.5	0.9	1.2	0.5	0.9	1.2
4	40	0.3	0.4	0.3	0.4	0.7	0.7	1.2	1.6	0.7	1.2	1.6	0.7	1.2	1.6
5	50	0.3	0.5	0.3	0.5	0.7	0.8	1.5	2.0	0.8	1.5	2.0	0.8	1.5	2.0
6	60	0.3	0.5	0.3	0.5	0.8	1.0	1.8	2.4	1.0	1.8	2.4	1.0	1.8	2.4
7	70	0.4	0.6	0.4	0.6	0.8	1.2	2.1	2.8	1.2	2.1	2.8	1.2	2.1	2.8
8	80	0.4	0.6	0.4	0.6	0.8	–	–	–	1.3	2.4	3.2	1.3	2.4	3.2
9	90	0.4	0.6	0.4	0.6	0.8	–	–	–	1.5	2.7	3.6	1.5	2.7	3.6
10	100	0.4	0.6	0.4	0.6	0.9	–	–	–	1.6	3.0	4.0	1.6	3.0	4.0
11	110	0.5	0.7	0.5	0.7	0.9	–	–	–	1.8	3.3	4.4	1.8	3.3	4.4

Maximum SWR

Table 7 Maximum SWR

Instrument	Frequency Range (GHz)	Maximum SWR
8495G	dc to 4	1.35
8495H	dc to 8	1.35
	8 to 12.4	1.5
	12.4 to 18	1.7
8494G, 8496G	dc to 4	1.5
8494H, 8496H	dc to 8	1.5
	8 to 12.4	1.6
	12.4 to 18	1.9

Maximum Residual Attenuation

Table 8 Maximum Residual Attenuation

Instrument	Maximum Residual Attenuation
8494G, 8494H	0.6 dB + 0.09 dB/GHz
8495G, 8495H	0.4 dB + 0.07 dB/GHz
8496G, 8496H	0.6 dB + 0.09 dB/GHz

Attenuation Repeatability

±0.03 dB max (5 million cycles per section).

RF Power Handling Capability

1 W average, 100 W peak with maximum pulse width of 10 microseconds (all models).

Solenoid Drive

Table 9 Solenoid Drive

Solenoid	Coil Voltage	Switching Current	Nominal Coil Impedance
Option 024	24 V (20 to 30 V)	125 mA (at 24 V)	190 Ω
Option 011	5 V (4.5 to 7 V)	325 mA (at 5 V)	17 Ω

Solenoid Cable Connector

Refer also to [Figure 3](#).

Table 10 Solenoid Cable Connector

Section	Section 1		Section 2		Section 3		Section 4		Power V+
	Thru-Line	Atten Card	Thru-Line	Atten Card	Thru-Line	Atten Card	Thru-Line	Atten Card	
Solenoid Coil									
Cable Wire Color Code ^[1]	PUR	YEL	BLK	GRN	ORN	BLU	BRN	WHT	RED
Connector Plug Pin Number ^[2]	5	6	7	8	9	10	11	12	1
8494G/H	0 dB	1 dB	0 dB	2 dB	0 dB	4 dB	0 dB	4 dB	–
8495G/H	0 dB	10 dB	0 dB	20 dB	0 dB	40 dB	–	–	–
8496G/H	0 dB	10 dB	0 dB	20 dB	0 dB	40 dB	0 dB	40 dB	–
Option 016 Flat Pack Plug Pin Number ^[3]	13	2	11	5	3	9	4	10	6

[1] Five-foot cable and mating plug assembly provided.

[2] Pin 1 Common solenoid drive (+24 Vdc).

[3] Pin 6 is common for all coils. Pins 1, 7, 8, 12, and 14 are not used.

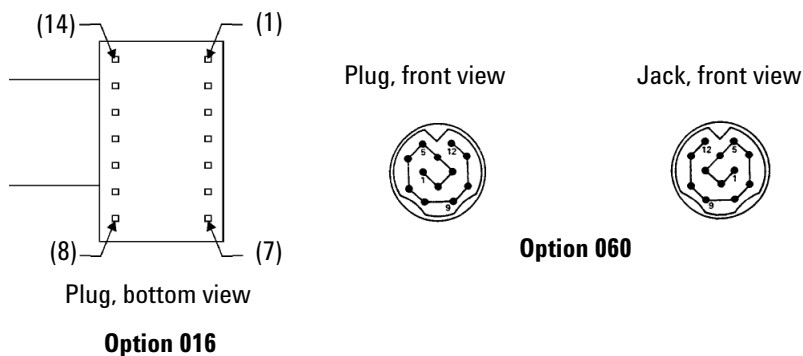

Figure 3 Solenoid Cable Pin Configuration

Operating Life

5 million cycles per section.

Switching Speed

Maximum 20 milliseconds including settling time.



2 Environmental Specifications & Physical Dimensions

Environmental Specifications 22

Physical Dimensions 23

This chapter contains the environmental tests on the Agilent 8494/95/96G/H Attenuators that fully comply with Agilent Technologies' product operating environmental specifications. The physical dimensions are illustrated in the later section.



Environmental Specifications

The Agilent 8494/95/96G/H Attenuators are designed to fully comply with Agilent Technologies' product operating environmental specifications as shown in [Table 11](#).

Table 11 Environmental Specifications

Temperature:	
• Operating	0 °C to +55 °C
• Storage	−40 °C to +75 °C
Humidity:	
• Operating	<95% relative
• Storage	<95% relative
Altitude:	
• Operating	<4600 m (15000 ft)
• Storage	<7600 m (25000 ft)
Shock:	
• Operating	10 Gs, six ms, on six sides, three blows
• Non-operating	500 Gs, 1.8 ms, in six directions
Vibration:	
• Operating	5 Gs, 34 Hz to 2000 Hz
EMC	Radiated interference is within the requirements of MIL-STD-461, RE02

Physical Dimensions

Table 12 shows the physical dimensions of the Agilent 8494/95/96G/H Attenuators.

Table 12 Physical Dimensions

Instrument	Dimensions ^[1]	Weight ^[2]
8494G/H	Per Figure 4	16 oz
8496G/H		454 g
8495G/H	Per Figure 4	12 oz
		340 g

[1] Dimensions are for general information only. If dimensions are required for building special enclosures, contact your Agilent field engineer.

[2] Weight and width of the instrument varies with the option selected due to the type of connectors.

2 Environmental Specifications & Physical Dimensions

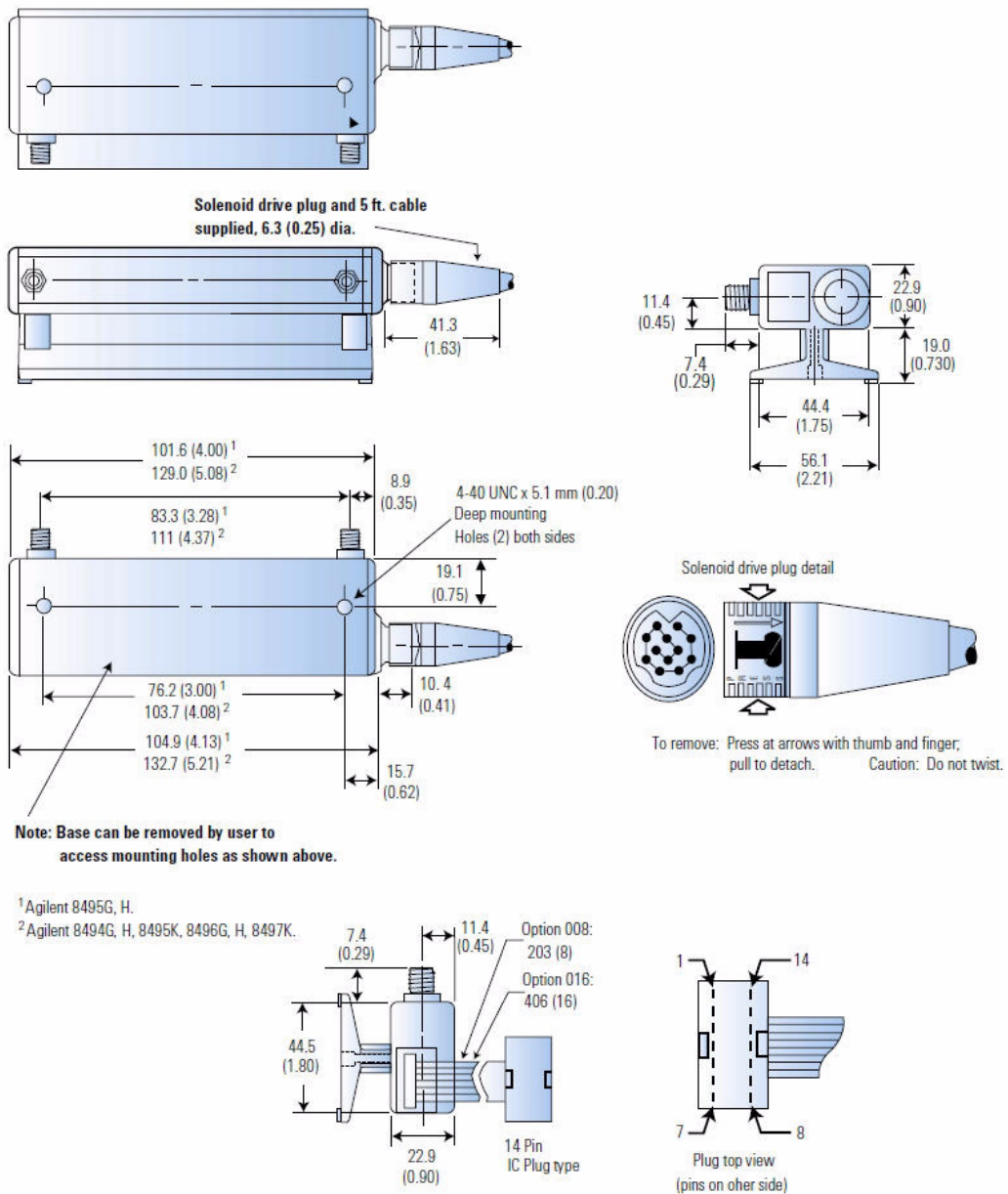

Figure 4 Dimensions of Agilent 8494/95/96G/H Attenuators



3 Operating Guides

Installation	26
Initial Inspection	26
Mating Connectors	27
Installation Instructions	27
Operating Instructions	28
Operator's Check	28
Performance Tests	31
Service Instructions	31

This chapter describes the installation of the Agilent 8494/95/96G/H Attenuators. The operating instruction quick-check procedure is included for verification test prior to usage. Service instructions on the repair and maintenance of the Agilent 8494/95/96G/H Attenuators are also included in this chapter.



Installation

Initial Inspection

- 1 Inspect the shipping container for damage. If the shipping container or cushioning material is damaged, it should be kept until the contents of the shipment have been checked for completeness and the instrument has been checked both mechanically and electrically.
 - Check for mechanical damage such as scratches or dents.
 - Procedures for checking electrical performance are given under “Operator’s Check” on page 28 or “Performance Tests” on page 31.
- 2 If the contents are incomplete, if there is mechanical damage or defect, or if the instrument does not pass the electrical performance test, contact the nearest Agilent Technologies Sales and Service office. Refer to the Service and Support information in the front matter of this manual. Agilent Technologies will arrange for repair or replacement of the damaged or defective equipment. Keep the shipping materials for the carrier's inspection.
- 3 If you are returning the instrument under warranty or for service, repackaging the instrument requires original shipping containers and materials or their equivalents. Agilent Technologies can provide packaging materials identical to the original materials. Refer to Service and Support information in the front matter of this manual for the Agilent Technologies nearest to you. Attach a tag indicating the type of service required, return address, model number and serial number. Mark the container **FRAGILE** to insure careful handling. In any correspondence, refer to the instrument by model number and serial number.

Mating Connectors

Mating RF connectors used with the Option 001 must be type-N male connectors, which comply with U.S. military standard MIL-C-39012. For Option 002, male SMA connectors must be used. For Option 003, 7 mm mating connectors must be used.

CAUTION

When installing the instrument, make sure that the connectors do not support weight or bear torque. The preferred procedure is to set up all equipment in position before connecting the instrument.

Installation Instructions

The attenuators may be installed with or without the base. The base is removed by unscrewing the two fillister head screws from the bottom of the base. The attenuator may be mounted without the base by inserting two 4-40 screws into the screw holes in the bottom of the attenuator. Removing the base and mounting the attenuator does not affect the performance of the attenuator.

The solenoid drive cable connector plug is connected to the attenuator by aligning the plug (PI) with the jack (JI) on the attenuator, and then pushing the plug over the jack. The plug is removed by grasping the ribbed sides of the plug and squeezing them together while pulling back until the plug clears the jack.

Operating Instructions

CAUTION

Do not apply RF power greater than 1 W average, or 100 W peak with a maximum pulse width of 10 microseconds. If these limits are exceeded, the attenuators may be damaged.

CAUTION

Do not ground both solenoid drive pins at the same time. This causes rapid cycling of the solenoid and could reduce the operating life of the attenuator. The rapid cycling may produce a buzzing sound from the attenuator.

Either RF connector may be used as the input or output connector. Connect the solenoid drive cable to the solenoid drive connector (J1). By applying the proper voltage and grounds to the proper pins of J1, the attenuator will either increase or decrease the amount of attenuation as selected.

Operator's Check

The Operator's Check is supplied to allow the operator to make a quick check of the instrument prior to use or if a failure is suspected.

Description

The attenuator is driven from a 50-ohm signal source at 1 kHz. The output level from the attenuator is detected by a narrow-bandwidth voltmeter. The attenuator and detector range switches are stepped together and the variations in level noted. This verifies that each attenuator section is being properly switched and checks the low-frequency accuracy of the attenuator.

NOTE

The SWR meter used in this check is calibrated for a square-law detector. Therefore, the range changes and errors (read in dB) are twice that indicated by the meter.

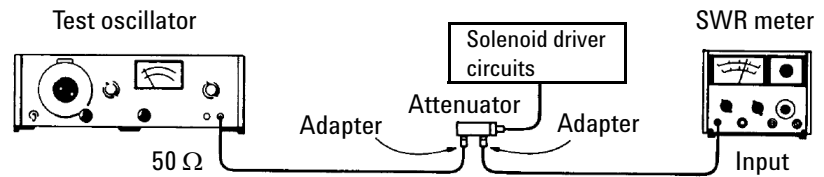

Figure 5 Operator's Check Setup

Procedure

- 1 Connect equipment as shown in [Figure 5](#) on [page 29](#) with the attenuator set to 0 dB attenuation.
- 2 Set the test oscillator to 0.3 V_{rms} at 1 kHz.
- 3 Set SWR meter range to 2 dB (expanded) [or for the 8494G/H to 10 dB (expanded)] and adjust its bandwidth to the center of the adjustment range. Fine-tune the oscillator frequency to obtain maximum meter indication.
- 4 Set attenuator and SWR meter range switch as listed in [Table 13](#) and verify that the SWR meter indicates within the limits shown.

3 Operating Guides

Table 13 Attenuator and SWR Settings

SWR Meter Range (dB)		Attenuation (dB)			Meter Indication (dB)					
					Minimum		Actual		Maximum	
8494G/H	8495G/H 8496G/H	8494G/H	8495G/H	8496G/H	8494G/H	8495G/H 8496G/H	8494G/H	8495G/H 8496G/H	8494G/H	8495G/H 8496G/H
10	2	0	0	0	–	–	Set to 0.0	Set to 0.5	–	–
10	6	1	10	10	0.40	1.40	–	–	0.60	1.60
10	12	2	20	20	0.90	0.30	–	–	1.10	0.70
10	16	3	30	30	1.35	1.25	–	–	1.65	1.75
10 ^[1]	22	4	40	40	1.85	0.15	–	–	2.15	0.85
12	26	5	50	50	0.35	1.10	–	–	0.65	1.90
12	32	6	60	60	0.85	0.00	–	–	1.15	1.00
12	36 ^[1]	7	70	70	1.30	0.90	–	–	1.70	2.10
12 ^[1]	42 ^[1]	8	–	80	1.80	–0.15	–	–	2.20	1.15
14	46 ^[1]	9	–	90	0.30	0.75	–	–	0.70	2.25
14	52 ^[1]	10	–	100	0.80	–0.30	–	–	1.20	1.30
14	56 ^[1]	11	–	110	1.75	0.60	–	–	1.75	2.40

[1] Adjust range by 2 dB, if needed, to obtain an on-scale indication.

Performance Tests

The Agilent 8494/95/96G/H Attenuators can be tested to the accuracy of the specifications with a network analyzer or equivalent equipment of suitable accuracy. If a network analyzer is available, test instrument using the procedure in the analyzer's operating manual.

Service Instructions

Adjustment

The Agilent 8494/95/96G/H Attenuators do not have internal adjustments and should not be opened.

Repair

The Agilent 8494/95/96G/H Attenuators are not recommended for repair as most components are not easily removed.

Maintenance

The connectors, particularly the connector faces, must be kept clean. For instruction on connecting and care of your connectors, refer to Microwave Connector Care Quick Reference Card (08510-90360).

This page is intentionally left blank.