

# Agilent RF & Microwave Attenuators

## Performance you can count on



### KEY FEATURES

- High reliability and exceptional repeatability reduce downtime
- Excellent RF specifications optimize test system measurement capability
- Broad portfolio of attenuation and connector options provide configuration flexibility



## Agilent RF & Microwave Attenuators

Agilent coaxial fixed and step attenuators are designed for use in a wide variety of signal conditioning and level control applications. Attenuators are generally used to reduce signal levels, improve matching impedances of sources and loads, and measure the gain or loss of two-port devices.

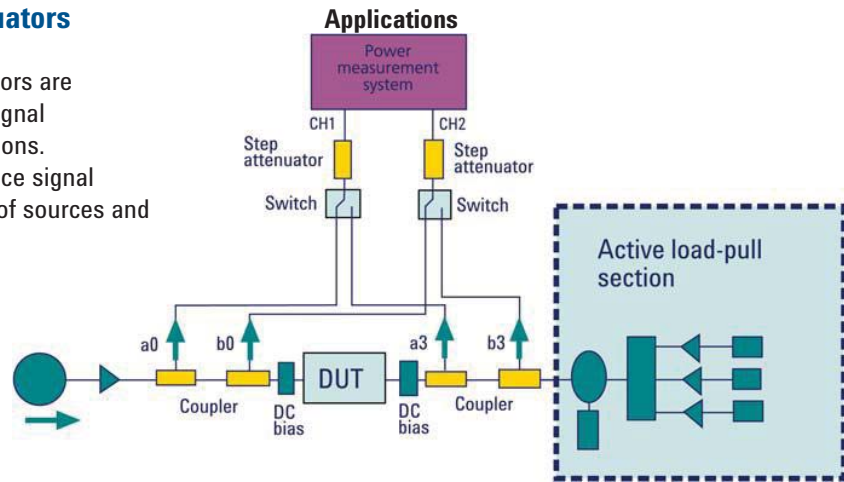

### Coaxial Fixed Attenuators

Agilent coaxial fixed attenuators provide precise attenuation, flat frequency response and low SWR over broad frequency range. These attenuators are available in nominal attenuations of 3, 6, 10, 20, 30, 40, 50 and 60 dB to cater to various applications and setups.

Coaxial Fixed Attenuators

Model number	Frequency	Attenuation Accuracy								Maximum SWR	Maximum input average power (W)	Maximum input peak power (W)	RF connectors
		3 dB	6 dB	10 dB	20 dB	30 dB	40 dB	50 dB	60 dB				
8491A	DC to 12.4 GHz	0.3	0.3	0.5	0.5	1.0	1.5	1.5	2.0	1.30	2	100	N (m,f)
8493A	DC to 12.4 GHz	0.3	0.3	0.5	0.5	1.0	-	-	-	1.30	2	100	SMA (m,f)
8491B	DC to 18 GHz	0.3	0.4	0.6	1.0	1.0	1.5	1.5	2.0	1.50	2	100	N (m,f)
8493B	DC to 18 GHz	0.3	0.4	0.6	1.0	1.0	-	-	-	1.50	2	100	SMA (m,f)
8498A	DC to 18 GHz	-	-	-	-	1.0	-	-	-	1.30	25	125	N (m,f)
8493C	DC to 26.5 GHz	1.0	0.6	0.5	0.6	1.0	1.3	-	-	1.25	2	100	3.5 mm (m,f)
8490D	DC to 50 GHz	1.8	1.8	1.3	1.7	1.7	2.5	-	-	1.45	1	100	2.4 mm (m,f)
8490G	DC to 67 GHz	1.8	1.8	1.3	1.7	1.7	2.5	-	-	1.45	1	100	1.95 mm

### Manual Step Attenuators

Agilent manual step attenuators offer fast, precise signal-level control up to 26.5 GHz. Unmatched attenuation repeatability of less than 0.03 dB up to 5 million cycles per section ensures low measurement uncertainty. Attenuation range of 121 dB in 1 dB step can be achieved by cascading 2 attenuators in series.

Manual Step Attenuators									
Model number	Frequency	Attenuation range (dB)	Attenuation step (dB)	Insertion loss (dB) at 0 dB	Maximum SWR	Maximum input average power (W)	Maximum input peak power (W)	Operating life (n million cycles/section)	Repeatability (dB)
8494A	DC to 4 GHz	0 to 11	1	0.96	1.50	1	100	5	± 0.03 dB max
8495A	DC to 4 GHz	0 to 70	10	0.68	1.35	1	100	5	± 0.03 dB max
8496A	DC to 4 GHz	0 to 110	10	0.96	1.50	1	100	5	± 0.03 dB max
8494B	DC to 18 GHz	0 to 11	1	2.22	1.90	1	100	5	± 0.03 dB max
8495B	DC to 18 GHz	0 to 70	10	1.66	1.70	1	100	5	± 0.03 dB max
8496B	DC to 18 GHz	0 to 110	10	2.22	1.90	1	100	5	± 0.03 dB max
8495D	DC to 26.5 GHz	0 to 70	10	3.95	2.20	1	100	5	± 0.03 dB max to 18 GHz, ± 0.05 dB max to 26.5 GHz

\*All product models listed above offer RF connector options for N(f) / SMA(f) / APC-7 except 8495D which only offer 3.5 mm (f) RF connectors.

## Programmable Step Attenuators

Agilent programmable step attenuators offer fast, precise signal-level control up to 50 GHz, with switching time of less than 20 ms. Unmatched attenuation repeatability of less than 0.03 dB up to 5 million cycles per section ensures low measurement uncertainty and reduces calibration cycles when installed into test systems. Automatic GPIB/USB/LAN drive control is achieved with the 11713B/C attenuator/switch driver.

Programmable Step Attenuators									
Model Number	Frequency	Attenuation Range (dB)	Attenuation Step (dB)	Insertion Loss (dB) @ 0 dB	Maximum SWR	Maximum input average power (W)	Maximum input peak power (W)	Operating Life (n million cycles/section)	Repeatability (dB)
8494G	DC to 4 GHz	0 to 11	1	0.96	1.50	1	100	5	± 0.03 dB max
8495G	DC to 4 GHz	0 to 70	10	0.68	1.35	1	100	5	± 0.03 dB max
8496G	DC to 4 GHz	0 to 110	10	0.96	1.50	1	100	5	± 0.03 dB max
8494H	DC to 18 GHz	0 to 11	1	2.22	1.90	1	100	5	± 0.03 dB max
8495H	DC to 18 GHz	0 to 70	10	1.66	1.70	1	100	5	± 0.03 dB max
8496H	DC to 18 GHz	0 to 110	10	2.22	1.90	1	100	5	± 0.03 dB max
8495K	DC to 26.5 GHz	0 to 70	10	3.95	2.20	1	100	5	± 0.03 dB max to 18 GHz, ± 0.05 dB max to 26.5 GHz
8497K	DC to 26.5 GHz	0 to 90	10	2.79	1.80	1	100	5	± 0.03 dB max to 18 GHz, ± 0.05 dB max to 26.5 GHz
84904K	DC to 26.5 GHz	0 to 11	1	1.86	2.00	1	50	5	± 0.03 dB max
84906K	DC to 26.5 GHz	0 to 90	10	1.86	2.00	1	50	5	± 0.03 dB max
84907K	DC to 26.5 GHz	0 to 70	10	1.40	1.90	1	50	5	± 0.03 dB max
84904L	DC to 40 GHz	0 to 11	1	2.40	2.00	1	50	5	± 0.03 dB max
84906L	DC to 40 GHz	0 to 90	10	2.40	2.00	1	50	5	± 0.03 dB max
84907L	DC to 40 GHz	0 to 70	10	1.80	1.90	1	50	5	± 0.03 dB max
84904M	DC to 50 GHz	0 to 11	1	3.00	3.00	1	50	5	± 0.03 dB
84905M	DC to 50 GHz	0 to 60	10	2.60	2.60	1	50	5	± 0.03 dB
84908M	DC to 50 GHz	0 to 65	5	3.00	3.00	1	50	5	± 0.03 dB

## Interconnect Kits

11716A Type-N interconnect kit  
 11716C SMA interconnect kit  
 11716D 2.9 mm interconnect kit  
 11716E 3.5 mm interconnect kit  
 11716F 2.4 mm interconnect kit

11716A/C/D/E/F interconnect kits can be used to connect any two of the Agilent 8494/95/96, 84904/8M, 84904/6L, or 84904/6K attenuators in series to achieve broader attenuation ranges with 1 dB attenuation step.

Attenuator	Interconnection Kit
8494x, 8495x, 8496x	11716A/C
84904L, 84906L, Option 006, 106	11716D
84904L, 84906L, Option 101, 100	11716F
84904K, 84906K	11716E

Attenuator type	Frequency range	Attenuator 1	Attenuator 2	Attenuation range	Attenuation step
Manual	DC to 4 GHz	8494A	8495A	81	1
Manual	DC to 4 GHz	8494A	8496A	121	1
Manual	DC to 18 GHz	8494B	8495B	84	1
Manual	DC to 18 GHz	8494B	8496B	121	1
Programmable	DC to 4 GHz	8494G	8495G	81	1
Programmable	DC to 4 GHz	8494G	8496G	121	1
Programmable	DC to 18 GHz	8494H	8495H	81	1

## Attenuator Sets

Sets of four coaxial fixed attenuators with attenuations of 3, 6, 10 and 20 dB are provided in a walnut accessory case. These sets are ideal for calibration labs or where precise knowledge of attenuation and SWR is desired.

Attenuator sets	Coaxial fixed attenuator model number	Attenuation
11581A	8491A	3, 6, 10 and 20 dB
11582A	8491B	3, 6, 10 and 20 dB
11853C	8493C	3, 6, 10 and 20 dB



myAgilent

[www.agilent.com/find/myagilent](http://www.agilent.com/find/myagilent)

A personalized view into the information most relevant to you.

### Agilent Channel Partners

[www.agilent.com/find/channelpartners](http://www.agilent.com/find/channelpartners)

Get the best of both worlds: Agilent's measurement expertise and product breadth, combined with channel partner convenience.



### Three-Year Warranty

[www.agilent.com/find/ThreeYearWarranty](http://www.agilent.com/find/ThreeYearWarranty)

Agilent's combination of product reliability and three-year warranty coverage is another way we help you achieve your business goals: increased confidence in uptime, reduced cost of ownership and greater convenience.



### Agilent Advantage Services

[www.agilent.com/find/AdvantageServices](http://www.agilent.com/find/AdvantageServices)

Accurate measurements throughout the life of your instruments.



[www.agilent.com/quality](http://www.agilent.com/quality)

### Related Products

11713A/B/C attenuator/switch driver

34980A multifunction switch/measurement unit

L4445A microwave switch/attenuator driver

For more information on Agilent test accessories

[www.agilent.com/find/mta](http://www.agilent.com/find/mta)

Or order an Agilent RF & Microwave Test Accessories catalog at [www.agilent.com/find/mtacatalog](http://www.agilent.com/find/mtacatalog)

[www.agilent.com](http://www.agilent.com)  
[www.agilent.com/find/mta](http://www.agilent.com/find/mta)

For more information on Agilent Technologies' products, applications or services, please contact your local Agilent office. The complete list is available at:

[www.agilent.com/find/contactus](http://www.agilent.com/find/contactus)

#### Americas

Canada	(877) 894 4414
Brazil	(11) 4197 3600
Mexico	01800 5064 800
United States	(800) 829 4444

#### Asia Pacific

Australia	1 800 629 485
China	800 810 0189
Hong Kong	800 938 693
India	1 800 112 929
Japan	0120 (421) 345
Korea	080 769 0800
Malaysia	1 800 888 848
Singapore	1 800 375 8100
Taiwan	0800 047 866
Other AP Countries	(65) 375 8100

#### Europe & Middle East

Belgium	32 (0) 2 404 93 40
Denmark	45 45 80 12 15
Finland	358 (0) 10 855 2100
France	0825 010 700*
	*0.125 €/minute
Germany	49 (0) 7031 464 6333
Ireland	1890 924 204
Israel	972-3-9288-504/544
Italy	39 02 92 60 8484
Netherlands	31 (0) 20 547 2111
Spain	34 (91) 631 3300
Sweden	0200-88 22 55
United Kingdom	44 (0) 118 927 6201

*For other unlisted countries:*

[www.agilent.com/find/contactus](http://www.agilent.com/find/contactus)

(BP-3-1-13)

Product specifications and descriptions in this document subject to change without notice.

© Agilent Technologies, Inc. 2013  
Published in USA, April 3, 2013  
5989-6948EN



Agilent Technologies