



ROHDE & SCHWARZ

Test and Measurement
Division

Operating Manual

VECTOR NETWORK ANALYZER

ZVR / ZVRE / ZVRL

1127.8551.61/.62

1127.8551.51/.52

1127.8551.41

ZVC / ZVCE

1127.8600.60/.61/.62

1127.8600.50/.51/.52

ZVM

1127.8500.60

ZVK

1127.8651.60

*Volume 1
Operating Manual consists of 2 volumes*

Printed in the Federal
Republic of Germany

Volume 1**Volume 2**

**Contents
Index**

**Data Sheet
Supplements**

**Safety Instructions
Certificate of Quality
EC-Certificate of Conformity
Support Center Address
List of R&S Representatives**

**Contents
Index**

**Safety Instructions
Certificate of Quality
EC-Certificate of Conformity
Support Center Address
List of R&S Representatives**

Tabbed Divider**Tabbed Divider**

1 Preparation for Use

2 Manual Operation

1 Remote Control

2 Maintenance and Troubleshooting

3 Testing the Rated Specifications

4 Annex A: Interfaces

5 Annex B: List of Error Messages

6 Annex C: List of Commands

7 Annex D: Programming Examples

8 Annex E: Emulations



ROHDE & SCHWARZ

Test and Measurement
Division

Release Notes

Firmware Version 3.52

for ZVR/ZVRE/ZVRL/ZVC/ZVCE/ZVM/ZVK

1112.7990.39

Printed in the Federal
Republic of Germany

Contents

| | |
|---|----|
| General Information | 1 |
| Manual for ZVR Family..... | 1 |
| Update Procedure | 1 |
| Initial Steps..... | 1 |
| Documentation of Firmware Modifications..... | 1 |
| 1 Firmware Update | 2 |
| System Requirements..... | 2 |
| Preparations for Update | 2 |
| Contents of Firmware Update Kit..... | 2 |
| Update Procedure | 2 |
| 2 New Features, Improvements and Modifications | 5 |
| New Features..... | 5 |
| Improvements | 6 |
| Modifications | 6 |
| 3 Bug Fixes | 7 |
| 4 Extensions to Operating Manual | 8 |
| 5 New IEEE-Bus Commands | 20 |
| 6 Special Features | 28 |

General Information

Manual for ZVR Family

The analyzers of the ZVR family are supplied with the following manual:

"Operating Manual – Vector Network Analyzer" ZVR/E/L, ZVC/E, ZVM, ZVK
Order No. 1127.8700.xx-03-

| | | |
|----------|----|-----------------------------|
| where xx | 11 | (German) |
| | 12 | (English) |
| | 13 | (French) |
| | 19 | (English, US letter format) |

Update Procedure

The update instructions given in section 1 of this release note are to the latest state; any deviating instructions in the operating manual are to be ignored.

If you have received this document together with a new analyzer, you can skip section 1.

If you have received the document together with a firmware update kit or as a download together with a self-extracting archive file, you should read section 1.

Initial Steps

If you work with a ZVR analyzer for the first time, it is recommended to read the operating manual to familiarize yourself with the unit.

If you are already familiar with the instrument, this document informs you about new features.

Documentation of Firmware Modifications

This document covers firmware modifications that are not part of the current operating manual.

1 Firmware Update

System Requirements

None

Preparations for Update

No preparations are required.

Contents of Firmware Update Kit

The update kit comprises the following:

- Five 3.5"/1.44 Mbyte disks labelled as follows:
 - Disk 1 : „V3.52 DISK 1“
 - Disk 2 : „V3.52 DISK 2“
 - Disk 3 : „V3.52 DISK 3“
 - Disk 4 : „V3.52 DISK 4“
 - Disk 5 : „V3.52 DISK 5“
- This document

Update Procedure

1. If you have received a self-extracting archive file per e-mail or as a download a set of disks must first be created from the archive file.

Proceed as follows:

- Check if you have received all files.
 - disk1.bin self extracting ZIP file, used to generate update disk 1
 - data2.cab packed contents of disk 2, automatically unpacked during FW update
 - data3.cab packed contents of disk 3, automatically unpacked during FW update
 - data4.cab packed contents of disk 4, automatically unpacked during FW update
 - data5.cab packed contents of disk 5, automatically unpacked during FW update
 - disk_d.bin this document packed
- Keep five DOS-formatted 3.5" / 1.44 Mbyte disks ready.
- Label disks as follows:
 - V3.52 DISK 1
 - V3.52 DISK 2
 - V3.52 DISK 3
 - V3.52 DISK 4
 - V3.52 DISK 5
- Create a temporary directory on your PC (e.g. ZVRTEMP on C:\). For this you require about 3 Mbytes of free memory on your hard disk.
- Copy file disk1.bin to this temporary directory.
- Rename file disk1.bin to disk1.exe.

- Execute disk1.exe, e.g. by using the following command sequence for Windows95/NT:
<CTRL><ESC> - RUN – C:\ZVRTEMP \DISK1 - <ENTER> (English version) or
<CTRL><ESC> - AUSFÜHREN – C:\ZVRTEMP \DISK1 - <ENTER> (German version).

The files are extracted.

- Delete file disk1.exe in the temporary directory.
The temporary directory should contain the following files:

| | | | | |
|--------------|------------|------------|------------|------------|
| _inst32i.ex_ | _isdel.exe | _setup.dll | _sys1.cab | _user1.cab |
| data.tag | data1.cab | lang.dat | layout.bin | os.dat |
| readme.txt | setup.exe | setup.ini | setup.ins | setup.lid |

- Copy all files to update disk 1 (V3.52 DISK 1).
Check if all files are on the disk with their correct names. In particular, the underscores ("_" as in "_inst32iex_") are essential for a successful update.
- The contents of the other 4 disks are already in the format needed for the update. Files data2.cab,..., data5.cab must be copied to the corresponding disks DISK2, ..., DISK5.

The disks are now ready, and you can continue with section 2 "If you have received a firmware update kit on a disk ...".

Notes: *If any error messages are output during creation of a disk, the installation process for the disk in question must be repeated. Before re-creating the disk, check if the write protection of the disk has been removed.*

File disk_d.bin contains this document in pdf format. To unpack the document proceed as follows:

- Copy disk_d.bin to the temporary directory.
- Rename the file to disk_d.exe.
- Execute disk_d.exe, e.g. by using the following command sequence for Windows95/NT:
<CTRL><ESC> - RUN – C:\ZVRTEMP \DISK_D - <ENTER> (English version)
or <CTRL><ESC> - AUSFÜHREN – C:\ZVRTEMP \DISK_D - <ENTER> (German version)

2. If you have received a firmware update kit on a disk ...

You can load the firmware directly from the disk to your network analyzer.

- Insert the disk DISK 1 into the drive.
- Press the **SETUP** key and change to the side menu by pressing ⇒ key.
- Press the **FIRMWARE UPDATE** softkey.
- Start the update by pressing the **UPDATE** softkey and follow the instructions on the analyzer display.

First, the contents of the update disks are copied to the hard disk of the instrument. Then the files are extracted and copied in the directories accordingly. After the extraction, the instrument is rebooted.

The firmware update is complete.

The previous firmware version may be restored using softkey **RESTORE**.

3. If problems occur during the firmware update ...

The new firmware can if necessary also be loaded under NT. This should be done only with an external keyboard and a mouse. Log-in has to be made using the ADMINISTRATOR function, and the device firmware closed.

Log in as administrator.

- Press key combination ALT SYSREQ to switch to NT screen if not yet displayed.
- Call up the NT task bar START – SHUT DOWN.
- Select 'Close all programs and logon as different user'.
- Hold the SHIFT key down and press the OK key to leave the input window until the login window appears.
- Release the SHIFT key as soon as the login window appears.
- Now enter administrator as user name and 894129 as password.

Close the device firmware:

- Press the keys **CTRL ALT DEL** on the external keyboard simultaneously.
- Select the Task Manager.
- Select the Application **Rohde&Schwarz ZVR NT Interface** and terminate it with **End Task**.

Now the new firmware can be loaded:

- Insert **DISK 1** into drive A:
- Start the installation with **START RUN A:SETUP**. You will be prompted to insert the remaining disks one after the other.

After loading the software, the operating system is rebooted. Then change back from **administrator** to instrument (password instrument) for the login. This is done in the same way as changing of login to administrator.

Note: *If the firmware is installed in this way, the previous version cannot be restored.*

2 New Features, Improvements and Modifications

New Features

- Support of waveguide calibration:
For this purpose, two new softkeys were added to the menu CAL → CAL KITS → right side menu: WAVEGUIDE (position 6) and CUTOFF FREQUENCY (position 7)
- Deinstallation of calibration kits:
A new softkey is available in the menu CAL → CAL KITS: UNINSTALL KITS (position 10)
- New SCPI commands:
 - Reading out and modification of system error calibration and power calibration
 - Support of waveguide calibration
 - Query of electrical length, mechanical length and phase delay
- Support of additional, external devices:
 - Generator SML (Rohde & Schwarz)
 - Generator SMR30, SMR50, SMR60, SMR30B11, SMR50B11, SMR60B11 (Rohde & Schwarz)
 - Generator HP8648 A/B/C/D (Agilent)
 - Generator HP83650A (Agilent)
 - Power Meter NRP (Rohde & Schwarz)
 - Power Meter ML2438A (Anritsu)
 - Power Meter E4417A (Agilent)
 - Power Meter EPM-441A (Agilent)

Improvements

- When reading and writing system error correction data and level correction data in the REAL64 format, an error message is output.
Affected IEC/IEEE bus commands:
SENSe[1..4]:CORRection:DATA
SENSe[1..4]:CORRection:POWer:DATA
SOURce[1..4]:POWer:CORRection:DATA
- If a waveguide calibration (WAVEGUIDE = ON) is performed via IEC/IEEE bus with a CUTOFF FREQUENCY that is higher than the START FREQUENCY, an error message is now output because this action is not permitted.
- Omission of unnecessary level calibration interpolation (improves performance especially during operation via the IEC/IEEE bus).
- The CALC:MARK:FUNC:RES? IEC/IEEE bus query now yields 10 significant marker points (previously only 6).
- Improvement of signal quality of R&S SMR generators (SMR20/27/30/40/50/60, SMR20/27/30/40/50/60B11) in TTL mode.
(This requires an SMR firmware version ≥ 1.26 .)
- Generators currently not used are switched to RF OFF. This prevents erroneous measurements and avoids disconnecting any cables.

Examples:

- During power calibration of the internal generator, any external generators connected to the instrument and set to REMOTE are switched to RF OFF.
- This applies analogously to the calibration of an external generator. In this case, the internal generator (and, if available, a second external generator connected and set to REMOTE) is switched to RF OFF.
- When a COMP/SOI/TOI, arbitrary or mixer measurement is switched off, the external generators used in the measurement are set to RF OFF.

Modifications

- New softkeys or softkeys shifted to another position in menu CAL → CAL KITS:
 - Softkey USER CONN NAME now at position 9 of right side menu
 - Softkey USER CONN IMPEDANCE now at position 10 of right side menu
 - New softkey UNINSTALL KITS at position 10 of main menu
 - New softkey WAVEGUIDE at position 6 of right side menu
 - New softkey CUTOFF FREQUENCY at position 7 of right side menu

3 Bug Fixes

- In the ACTIVE xx STANDARDS table, the entries for the OPEN standards are again available when a calibration is performed.
- System error correction data sets generated with a version <3.50 can now be recalled again (RECALL).
- The power correction function has been improved:
 - External power calibration is reliably activated with COMP/SOI/TOI measurements.
 - An existing power calibration can be used again in power sweeps and in time sweeps.
- The normal user (logged on under the name "INSTRUMENT") has write access again to the directory AUTOKAL, so the AutoCal function works again.
- Commanding the OFFSET SHORT standards (SENSe[1..4]:CORRection:COLLect:ACQuire:OSHORT1 or OSHORT2) in case of waveguide calibration (WAVEGUIDE = ON) is possible again.
- Errors were corrected in the following SCPI commands:
 - SENS:FUNC?
 - SOURce:POWer:[LEVel]:[IMMEDIATE]:CAMPliTude
- Softkeys that were not visible are now available again:
 - Menu MEAS → USER DEF'D S-PARAMS: softkeys USER DEF'D S-PARAMS and USER DEF ACTIVE
 - Menu CAL → START NEW CAL → FULL ONE PORT → BOTH PORTS: softkey 2.92 mm FEMALE
 - Menu MEAS → WAVE QANTITY: softkey DRIVE PORT

4 Extensions to Operating Manual

Characteristics of Calibration Standards (Re section 2.15.1.3)

The *MODIFY CAL KIT* softkey opens a menu for the management of calibration kits for the individual connector families.

Exact knowledge of the calibration standards is a prerequisite for a accurate system-error calibration. More precisely, the calibration is based on the knowledge of those S-parameters of the standards which are assumed to be known for the applied calibration method. These S-parameters are derived from physical models which contain one or more parameters (such as the electrical length) depending on the type of standard.

In addition to these physical parameters, there are three description fields for each standard listing the assignment of the standard and further information for the user.

1. Standard type: The type depends on the kind of standard (e.g. open circuit, short circuit, through-connection) and the sex of the connectors. Example: *THROUGH (MF)* denotes a through-connection with a plug at one and a socket at the other port. The standard type determines the physical description model and therefore the parameters which can be edited. Up to four individual standards with different parameters can be defined for one standard type. Only one of them can be selected (active) at one time.
2. Calibration kit (*KIT*): A calibration kit is an assembly of real, physical calibration standards. Calibration kits are supplied by Rohde & Schwarz as an accessory for network analyzers. The parameters of the standards in a calibration kit are stored on a floppy disk which can be read in via the *INSTALL NEW KIT* softkey. Kits for coaxial connector families usually do not contain all possible standard types of these families but only a subset comprising the types which are most frequently used in coaxial technology. Calibration kits can be user-defined as well. Using the *ACTIVATE KIT* softkey, the standards of a calibration kit can be selected altogether by just one keystroke.
3. Serial number (*SERIAL #*): All standards of a calibration kit are factory-labelled with the same serial number so they can be assigned unambiguously to this kit. The serial number helps to avoid confusion between standards of the same type from different calibration kits which might have different physical parameters.

CAL CAL - CAL KITS submenu:

| ACTIVE N 50 Ω STANDARDS | |
|--------------------------------|-----------|
| STANDARD TYPE | KIT |
| THROUGH (MM) | ZV-Z21 |
| THROUGH (FF) | ZV-Z21 |
| THROUGH (MF) | ZV-Z21 |
| LINE 1 (MM) | |
| LINE 1 (FF) | |
| LINE 1 (MF) | ZV-Z26 |
| LINE 2 (MM) | |
| LINE 2 (FF) | |
| LINE 2 (MF) | ZV-Z26 |
| ATTENUATION (MM) | |
| ATTENUATION (FF) | |
| ATTENUATION (MF) | |
| SYMM NETWORK (MM) | |
| SYMM NETWORK (FF) | |
| SYMM NETWORK (MF) | |
| OPEN (M) | ZV-Z21 |
| OPEN (F) | ZV-Z21 |
| SHORT (M) | ZV-Z21 |
| SHORT (F) | ZV-Z21 |
| REFLECT (M) | OPEN PORT |
| REFLECT (F) | OPEN PORT |
| MATCH (M) | ZV-Z21 |
| MATCH (F) | ZV-Z21 |
| SLIDING MATCH (M) | ZV-Z41 |
| SLIDING MATCH (F) | ZV-Z41 |

NOTE: The connector sex refers to the ports of the standards!

Selecting the connector families

After pressing the *CAL KITS* softkey, the *ACTIVE XX STANDARDS* selection table is displayed, where *XX* denotes the connector family selected. By default, the connector family of the test set ports is selected. The table gives an overview of the active standards of the connector family:

- The *STANDARD TYPE* column lists all standard types which are required for the calibration procedures of the respective type of instrument.
- The *KIT* column indicates to which calibration kit the currently selected physical standard belongs. By default, for standard types contained in the calibration kits offered by Rohde & Schwarz, the designation of the corresponding kit is also displayed. Although typical parameter values are pre-defined for these standards, the individual parameters for each calibration kit, which are supplied on a floppy, should be read in for the sake of maximum accuracy (see *INSTALL NEW KIT* softkey). The predefined standards without calibration kit assignment are assumed to be ideal.

The cursor can be used to select the standard type the softkeys *MODIFY STANDARDS* and *VIEW ACTIVE STD* refer to.

For polarized connector families, three types exist for each two-port standard, namely male/male (MM), female/female (FF), and male/female (MF). One-port standards are provided as male (M) and female (F). For non-polarized connectors, such as PC 7, all standards are contained only once in the table.

If a calibration method requires to measure two standards with the same polarity simultaneously, their characteristics are assumed to be identical. This applies, e.g., to the TOM-X calibration method if the *OPEN BOTH PORTS* measurement is performed.

The following types of standards are provided for the various types of network analyzers. Due to the restricted calibration facilities of the ZVRE, ZVCE and ZVRL compared to the ZVR, ZVC, ZVK and ZVM, a reduced set of standards is required only.

Table: Standard types for the network analyzers

| ZVR, ZVC, ZVK, ZVM | ZVRE, ZVCE, ZVRL | |
|--------------------|------------------|---|
| THROUGH | THROUGH | through-connection |
| LINE 1 | | line 1 for TRL calibration procedure |
| LINE 2 | | line 2 for TRL calibration procedure |
| ATTENUATION | | unknown matched attenuator |
| SYMMETRIC NETWORK | | unknown mismatched reflection-symmetric two-port standard |
| OPEN | OPEN | open circuit |
| SHORT | SHORT | short circuit |
| OFFSET SHORT | OFFSET SHORT | additional short circuit for waveguide calibration |
| REFLECT | | unknown mismatched one-port standard |
| MATCH | MATCH | broadband termination |
| SLIDING MATCH | SLIDING MATCH | sliding load |

CAL CAL - MODIFY CAL KIT - SELECT KIT submenu:

| CAL KITS | CONNECTOR TYPE |
|---------------------|-----------------------|
| CONNECTOR TYPE | N 50 Ω |
| ACTIVATE KIT | N 75 Ω |
| MODIFY STANDARDS | |
| VIEW ACTIVE STD | PC 7 |
| | |
| RESTORE INSTD KITS | SMA |
| LIST INSTD KITS | PC 3.5 |
| INSTALL NEW KIT | |
| USER CONN NAME | SEXLESS USR CONN 1 |
| USER CONN IMPEDANCE | USR CONN 2 |

The *CONNECTOR TYPE* softkey calls a menu for selecting the connector family shown in the *ACTIVE XX STANDARDS* table.

The type and order of the connectors shown in this menu are different for the different models of the ZVx family. The connector types used for the instrument test ports always come at the uppermost position. This is also the default setting.

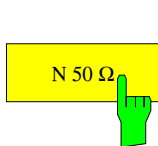
The following connector families are provided:

- N 50 Ω,
- N 75 Ω,
- PC 7,
- SMA,
- PC 3.5,
- 2.92 mm.

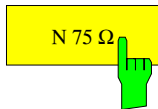
In addition two connector families can be arbitrarily defined, namely:

- SEXLESS USR CONN 1
- USR CONN 2

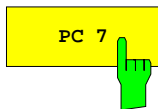
Only the two user-defined connector families can be configured for waveguide calibration.



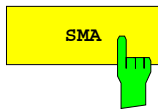
The *N 50 Ω* softkey displays the table *ACTIVE N 50 Ω STANDARD*.



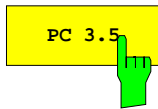
The *N 75 Ω* softkey displays the table *ACTIVE N 75 Ω STANDARDS*.



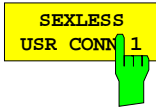
The *PC 7* softkey displays the table *ACTIVE PC 7 STANDARDS*.



The *SMA* softkey displays the table *ACTIVE SMA STANDARDS*.



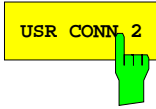
The *PC 3.5* softkey displays the table *ACTIVE PC 3.5 STANDARDS*.



The *SEXLESS USR CONN 1* softkey displays the table *ACTIVE USER CONN 1 STANDARDS*. The connector family *SEXLESS USR CONN 1* which can be user-defined is not polarized (similar to PC 7) and particularly suited for non-coaxial cable systems such as microstrip.

The two user-defined connector families *SEXLESS USR CONN 1* and *USR CONN 2* can also be used for waveguide calibration (refer to *WAVEGUIDE* softkey description). As waveguides are as a rule not polarized, *SEXLESS USR CONN 1* is to be preferred to *USR CONN 2*.

The name of this connector family (*USR CONN 1* by default) can be modified via the *USER CONN NAME* softkey.



The *USR CONN 2* softkey displays the table *ACTIVE USER CONN 2 STANDARDS*. Unlike *SEXLESS USR CONN 1*, this user-defined connector family is polarized and therefore suited for the coaxial connectors that are not pre-defined in the *CONNECTOR TYPE* menu. The connector family *USR CONN 2* can also be used for waveguide calibration.

The name of this connector family (*USR CONN 2* by default) can be modified via the *USER CONN NAME* softkey.

CAL CAL - CAL KITS submenu:



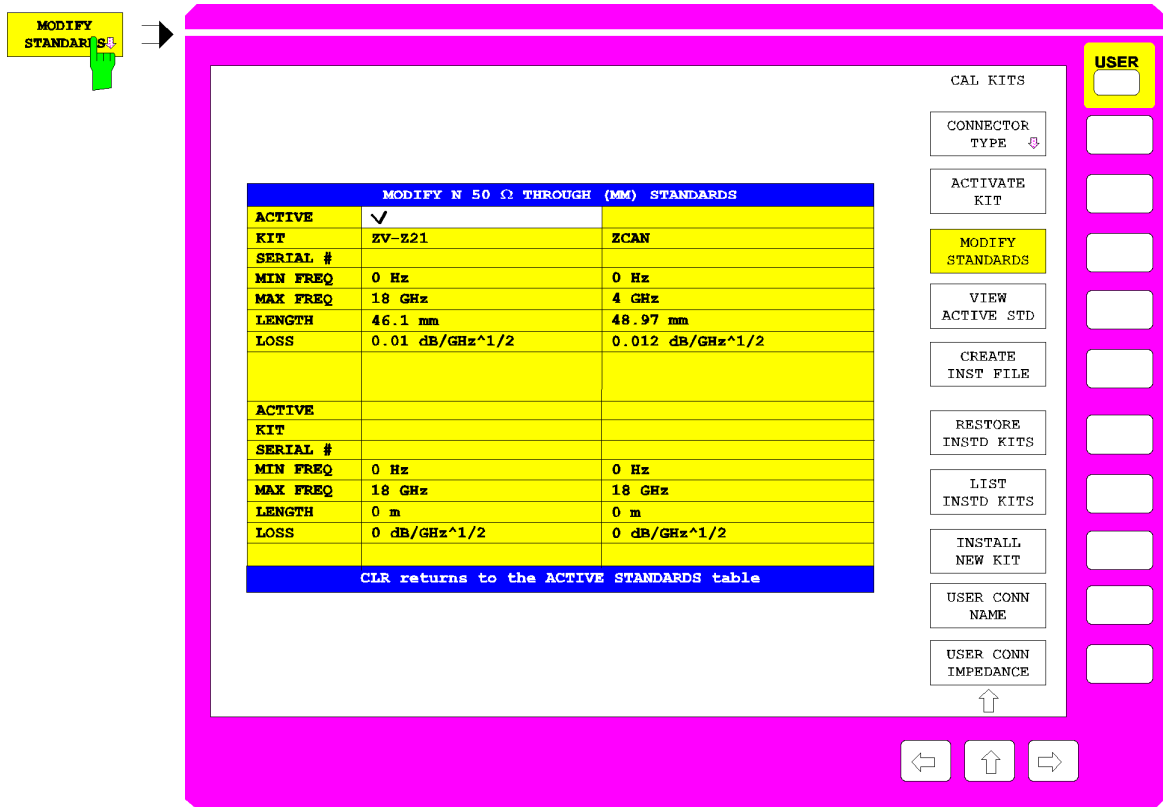
The *ACTIVATE KIT* softkey displays the selection table *ACTIVATE KIT*.

| ACTIVATE KIT |
|--------------|
| OPEN PORT |
| ZCAN |
| √ ZV-Z21 |
| ZV-Z26 |
| ZV-Z28 |
| ZV-Z41 |
| |
| |

This table lists all calibration kit names defined for the connector family currently selected. All standards including the ones that are currently not active are considered.

The cursor keys move the cursor within the table. A kit is selected via the units prefix key. A checkmark displayed for a short time indicates that a kit has been selected.

All standards with the selected kit name are set active.



Modifying the standards

The *MODIFY STANDARDS* softkey calls the *MODIFY XX YY STANDARDS* table.

In the four quadrants of this table, the parameters of the four individual standards of a single type are displayed. The type is selected in the *ACTIVE XX STANDARDS* table. The parameters describe the physical model of this standard type. All displayed parameters can be edited, even if the corresponding standard is currently not set. The upper five parameters are available for all standard types, the remaining ones depend on the kind of model applied.

If a parameter in this table is changed, an asterisk (*) is appended to the calibration kit name (*KIT*) of the corresponding standard.

ACTIVE **Standard active**

A checkmark in the table row *ACTIVE* indicates which one of the individual standards is currently active. If a definite standard type, e.g. an OPEN (F), is measured in a calibration, the calibration algorithm uses the parameters of the active individual standard of this type.

KIT **Designation of the calibration kit**

The calibration kit name can be entered here. It comprises a maximum of 10 characters and appears in the *ACTIVE XX STANDARDS* table if the standard is activated.

Some softkey functions access the calibration kit name as well. The standards with the same kit name can be activated altogether via *ACTIVATE KIT*. The softkey *RESTORE INSTD KITS* restores the original parameters of the calibration data sets which were installed from floppy disk. *LIST INSTD KITS* list all calibration data of a connector type installed from floppy disk.

An asterisk (*) as the last character of the kit name indicates that the preset values or the values installed from floppy of one or several parameters of the corresponding individual standard were changed. If an attempt is made to enter a calibration kit name which is already present twice (e.g. once in the original form and once labelled as user-defined, i.e. with an asterisk), an exclamation mark and an asterisk will be appended to the name.

SERIAL # Serial number of the standard

Besides the calibration kit name, the serial number (max. 15-digit) is a further individual attribute for the standards. It is used especially to distinguish standards from calibration kits of the same type. For the calibration kits offered by Rohde & Schwarz, the same serial number is used throughout the whole kit. This number is assigned to every single standard when the kit is installed. Standards purchased later as spare parts have another serial number of course.

MIN FREQ – minimum frequency of the standard

The sliding load, e.g., is a standard with minimum frequency since it can be used above 2 GHz only.

MAX FREQ – maximum frequency of the standard

For each standard, a maximum frequency is defined. The physical model described by the subsequent parameters is valid up to this maximum frequency.

LENGTH – electrical length of the standard

The electrical length of the standard can be entered for *OPEN*, *SHORT*, *OFFSET SHORT (short with length offset)*, *REFLECT*, *THROUGH*, *LINE 1* and *LINE 2* and *SYMMETRIC NETWORK*. The default unit of the electrical length is mm. For *REFLECT* and *SYMMETRIC NETWORK*, the electrical length must be specified only if it causes a phase deviation of more than 90° from the assumed approximation (*APPROX* field) in the frequency range to be calibrated.

Note: For one-port standards, only the single length (length offset) is to be entered, too.

LOSS – losses

The losses of the standard are entered in this field. It is assumed that they are resistive line losses whose value (in dB) increases proportionally with the root of the frequency due to the skin effect. The attenuation is thus entered in units of dB/GHz. Losses are indicated only for *OPEN*, *SHORT*, *OFFSET SHORT (short with length offset)*, *THROUGH* and *LINE*. For one-port standards, the total loss, i.e., the return loss must be entered.

C0... C3 – polynomial coefficients for parasitic capacitance

For *OPEN*, as well as for *REFLECT* and *SYMMETRIC NETWORK* with *APPROX = OPEN* selected, the parasitic capacitance at the open end of the line can be described by a third-order frequency polynomial. C0 denotes the constant part, C1 to C3 the polynomial coefficients of the corresponding powers of the frequency. The unit of the coefficient Cn is thus fF/GHzⁿ (n=0,..., 3).

For *REFLECT* and *SYMMETRIC NETWORK*, specification of the coefficients is required only if the latter cause a phase deviation of more than 90° from the assumed *OPEN* approximation in the frequency range to be calibrated.

L0... L3 – polynomial coefficients for parasitic inductance

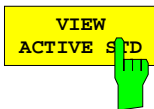
For *OPEN*, as well as for *REFLECT* and *SYMMETRIC NETWORK* with *APPROX = SHORT* selected, the parasitic inductance can be described by a third-order frequency polynomial. L0 denotes the constant part, L1 to L3 the polynomial coefficients of the corresponding powers of the frequency. The unit of the coefficient Ln is thus pH/GHzⁿ (n=0,..., 3).

For *REFLECT* and *SYMMETRIC NETWORK*, specification of the coefficients is required only if the latter cause a phase deviation of more than 90° from the assumed *SHORT* approximation in the frequency range to be calibrated.

APPROX – approximate modelling

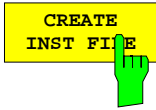
When a reflection standard (*REFLECT*) or a reflection-symmetric network (*SYMMETRIC NETWORK*) is selected, it must be indicated, whether the unknown reflection coefficient can be approximately modelled as a short or an open circuit.

This information is required only to exclude a sign ambiguity when the reflection coefficient is determined implicitly. If the length offset or parasitic reactances cause a rotation of the phase of the unknown reflection coefficient of more than 90° with respect to the approximate phase (0° for *APPROX = OPEN*, 180° for *SHORT*), these parameters must be specified as well.



The *VIEW ACTIVE STD* softkey displays the *ACTIVE XX YY* table, where XX denotes the connector family and YY the standard type, e.g. ACTIVE N 50 Ω OPEN (F).

This table can not be edited. It shows the parameters of the currently active individual standard of the type that was selected in the *ACTIVE XX STANDARDS* table. If a certain standard type, e.g. an OPEN (F) is measured during a calibration, the calibration algorithm uses the parameters of the active individual standard of this type. For a description of the table rows refer to softkey *MODIFY STANDARDS*.



The *CREATE INST FILE* softkey creates an installation file for a calibration kit. This function is useful, e.g., if an updated installation file for the entire calibration kit is needed after exchange of an individual calibration standard, or if calibration kit data entered via *MODIFY STANDARDS* are to be transferred to other instruments. The *SELECT KIT* table shows all calibration kits of the connector type currently selected.

Once the desired kit has been selected and confirmed via the ENTER key, an input field for the path and name of the installation file is displayed. The default entries correspond to the current path for *SAVE / EDIT* and the name of the selected calibration kit with the extension *.chk. Upon entering the name the installation file is written to the specified directory.

To create an updated installation file for the entire calibration kit after exchanging an individual calibration standard, the file supplied with the replacement standard is installed first. During installation, only the data pertaining to this standard are overwritten in the corresponding calibration kit file. Afterwards, the desired file for the entire kit can be created via *CREATE INST FILE*.

To create an installation file for calibration kits from other manufacturers, the data describing the different standards is entered via *MODIFY STANDARDS*; the entire data is assigned to the same calibration kit. Afterwards, *CREATE INST FILE* is used to create the installation file.



The *RESTORE INSTD KITS* softkey resets the parameters of all standards to the values defined in the instrument firmware. Exceptions are calibration kits installed from floppy disk (or from another storage medium). Those are reset to their original state after the installation.

The softkey also activates the same standards which were active in the preset state. Besides that, the default values of the name and reference impedance of the connector families which can be user-defined (*SEXLESS USR CONN 1* and *USR CONN 2*) are restored. This function is used to cancel all user entries, especially the ones made by mistake.



The *LIST INSTD KITS* softkey displays the *INSTALLED CAL KITS* table.

This table can not be edited. It shows all calibration kits which were installed from floppy disk (or from another storage medium) or which were generated by modifying an originally installed calibration kit. Preinstalled kits or kits generated by modification of an originally preinstalled kit are not listed.

| INSTALLED CAL KITS | | |
|--------------------|--------|------------|
| CONNECTOR | KIT | SERIAL # |
| N50Ω | ZV-Z21 | 123456/001 |

CONNECTOR Connector family

The CONNECTOR column shows the connector family of the calibration kit.

The meaning of the two columns *KIT* and *SERIAL #* is as explained under softkey *MODIFY STANDARDS*. If the standards of a kit have different serial numbers *VARIOUS* is indicated in the *SERIAL #* column.



The *INSTALL NEW KIT* softkey allows the user to install calibration kits from a floppy disk or another storage medium.

If a floppy containing a single calibration kit file (this applies to all floppies provided with the calibration kits from Rohde & Schwarz) is inserted into the disk drive a message window indicating the connector type and the kit designation is displayed after a short time. In this window, installation of the new kit must be confirmed. The calibration kit is read in and a new message indicates that the installation was successfully completed.

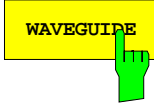
If several calibration kit files (file extension *.ck) are stored on the floppy, or if no floppy is in the disk drive, the input field *EDIT CAL KIT PATH* is invoked where the path and file name of the desired calibration kit file can be entered. The further procedure is as described above.



The *UNINSTALL KITS* softkey allows the user to delete the user-installed calibration kits for a connector family.

User-installed calibration kits are meant to include calibration kits read in from a storage medium by means of the *INSTALL NEW KIT* function. They do not mean to include the preinstalled kits contained in the instrument firmware. Please note that this function deletes **all** user-installed calibration kits for the connector family selected in the *CONNECTOR TYPE* menu (e.g. PC 3.5).

To preserve particular user-installed calibration kits, they must first be saved by means of the *CREATE INST FILE* function.



The connector families *SEXLESS USR CONN 1* and *USR CONN 2* can also be configured for waveguide calibration by means of the *WAVEGUIDE* softkey. If this softkey is activated, the instrument takes into account the nonlinear relationship between the phase of the S-parameters and the frequency, which prevails in waveguides. This effect is also known as dispersion.

At the frequency f , the transmission phase φ , e.g. of a *THROUGH* or a *LINE* standard of the length l , is not governed by the relationship

$$\varphi = \frac{2\pi f}{c} \cdot l \quad \text{but by}$$

$$\varphi = \frac{2\pi f}{c} \cdot l \cdot \sqrt{1 - \left(\frac{f_c}{f}\right)^2},$$

where f_c is the cutoff frequency of the waveguide mode used (normally the basic mode).

When the *WAVEGUIDE* softkey is activated, the *CUTOFF FREQUENCY* softkey for entering the cutoff frequency is available too.

The *OPEN* standard is unsuitable with waveguide calibration because in this case it does not provide total reflection but radiates like an antenna. Therefore, if the *WAVEGUIDE* softkey is switched on, the *OPEN* standards are replaced by *SHORTS* (for standards table see *CAL CAL - CAL KITS* submenu). The latter must have a length offset different from the existing *SHORTS* and are for this reason referred to as *OFFSET SHORTS*. At frequencies at which the length difference between the *SHORT* and the *OFFSET SHORT* equals a multiple of $\lambda/2$, singularities occur since the shorts have identical reflection coefficients in this case. To avoid this, the length offset of the *OFFSET SHORT* should be selected to obtain a length difference of $\lambda/4$ between the *SHORT* and the *OFFSET SHORT* in the middle of the measurement frequency range. The associated reflection coefficients are then exactly opposite in phase. As the frequency range is normally not larger than the single-mode range of the waveguide, i.e. max. one octave, singularities do not occur at the range limits either if the length offset is selected as described.

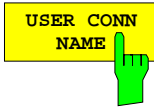
The *SHORT* of a waveguide calibration kit is usually in the form of a plate, i.e. it has no electrical length. The effects of attenuation and leakage inductance can be neglected in practice. The *OFFSET SHORT* is in most cases realized by a *SHORT* to which a piece of line ($\lambda/4$) (shim) is added. The electrical length of this added line is entered as the length offset for the *OFFSET SHORT*. The effects of attenuation and leakage inductance can usually also be neglected for the *OFFSET SHORT*.

Note: The $\lambda/4$ line can also be used as a LINE standard, for example for TRL calibration.



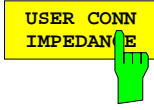
The *CUTOFF FREQUENCY* softkey opens an input field for entering the cutoff frequency for the waveguide mode for which calibration is to be made. This is usually the basic mode of the waveguide.

The waveguide mode cannot propagate below the cutoff frequency, which means that system error correction is not possible below this point. The cutoff frequency, therefore, represents the minimum start frequency for measurement and calibration. If the start frequency of the calibration range is lower than the entered cutoff frequency (e.g. after a *PRESET*), an error message is output.



The *USER CONN NAME* softkey activates the entry of a name comprising up to 11 characters for the connector families *SEXLESS USR CONN 1* and *USR CONN 2*. The name refers to the family selected in the *CONNECTOR TYPE* menu. In the title of the tables *ACTIVE XX STANDARDS*, *MODIFY XX YY STANDARDS* and *ACTIVE XX YY*, it replaces the character string *XX*. The name of the corresponding softkeys in the *CONNECTOR TYPE* submenu, however, can not be overwritten.

The default names are *USER CONN 1* and *USER CONN 2*.



The *USER CONN IMPEDANCE* softkey activates the entry of the reference impedance for the connector *SEXLESS USR CONN 1* or *USR CONN 2*. The impedance refers to the family selected in the *CONNECTOR TYPE* menu. The default value is 50 Ω .

Note: Only a constant reference impedance can be entered via this softkey. While the characteristic impedance of a waveguide is highly frequency-dependent, the conversion of reflection coefficients to impedances or the calculation of Z parameters in the waveguide are irrelevant in practice.

5 New IEEE-Bus Commands

CALCulate:MARKer Subsystem (Re section 3.6.3.5)

The CALCulate:MARKer subsystem controls the marker functions.

| COMMAND | PARAMETER | UNIT | COMMENT |
|--|---|--|--|
| CALCulate<1..4> :MARKer<1...8> [:STATe] :AOFF :MODE :COUPled [:STATe] :X :MODE :Y? :FORMat :TRANSform :COMpLex :TRACe :SEARch [:IMMEdiate] :NEXT :RIGHT :LEFT :TRACKing :MAXimum :MINimum | <Boolean> CONTinuous DISCrete <Boolean> <numeric_value> ABS REL MLINear MDB PHASe REAL IMAGinary SWR GDELay MLPHase MDPHase COMpLex L C RLC S SINV Z ZREL Y YREL CHDATA CHMEM -- -- -- -- -- -- -- -- | -- -- HZ S DBM -- -- -- -- -- -- -- -- -- -- | no query query only no query no query no query no query -- no query no query |
| :FUNctIon [:SElect] :BWIDTH :MODE :QFACTOR :SFACTOR :TARGet :RESULT? :EDELay :VALue? :DELTA :STATe :REFerence | MAXimum MINimum TARGet BFILter <numeric_value> BPASs BSTop -- <numeric_value>,<numeric_value> <numeric_value> TIME DISTance ELENgth OFF <Boolean> MARKER1 MARKER2 MARKER3 MARKER4 MARKER5 MARKER6 MARKER7 MARKER8 FIXed | DB -- -- -- DBM DB -- -- | query only query only |

| COMMAND | PARAMETER | UNIT | COMMENT |
|--|--|---|--|
| :RPOsition [:CARTesian] POLar | <numeric_value>,<numeric_value> <numeric_value>,<numeric_value>, <numeric_value> | HZ S DBM,DB HZ S DBM,DB, DB | |
| :PTPeak :STATe :RESult? | <Boolean> [ALL] | -- | query only no query no query no query no query |
| :CENTer :STARt :STOP :REFerence | | | |

CALCulate[1...4]:MARKer[1...8]:FUNcTion:EDELay

This command switches on or off the display of the electrical or the mechanical length or the phase delay. The suffix of MARKer has no meaning. The parameter information means the following:

- ELENgth = electrical length
- DISTance = mechanical length
- TIME = phase delay
- OFF = display switched off

Syntax: CALCulate[1...4]:MARKer[1...8]:FUNcTion:EDELay TIME | DISTance | ELENgth | OFF

Example: "CALC:MARK:FUNC:EDEL TIME"

Features: *RST value: OFF
SCPI: device-specific

CALCulate[1...4]:MARKer[1...8]:FUNcTion:EDELay:VALue?

This command queries the value of the electrical or the mechanical length or the phase delay. The format of the return value must be selected beforehand with CALC:MARK:FUNC:EDEL. The suffix of MARKer has no meaning.

Syntax: CALCulate[1...4]:MARKer[1...8]:FUNcTion:EDELay:VALue?

Example: "CALC:MARK:FUNC:EDEL:VAL?"

Features: *RST value: --
SCPI: device-specific

This command is a query only and therefore has no *RST value.

SENSe:CORRection Subsystem (Re section 3.6.14.3)

The SENSe:CORRection subsystem controls the system error correction and the recording of the individual correction values.

| COMMAND | PARAMETER | UNIT | COMMENT |
|---|--|------|------------|
| :CORRection [:STATe] :DATA :DATE? :INTerpolate [:STATe] :AKAL :SElect :EXPort :IMPort :CLEar :REName :COLlect [:ACQuire] | <Boolean> <string>,<block> <numeric_value>... | | query only |
| :METHod | THROUGH OPEN1 OPEN2 OPEN12 SHORT1 SHORT2 MATCH1 MATCH2 MATCH12 NET ATT IMATCH12 REFL1 REFL2 SLIDE1 SLIDE2 SLIDE12 LINE1 LINE2 M1O2 O1M2 OSHORT1 OSHORT2 AKAL | | no query |
| :SAVE :CONNection<1 2> | FTRans RTRans FRTRans TOM TRM TRL TNA TOMX TOSM FUNDAMENTAL FOPORT1 FOPORT2 FOPORT12 FOPTport ROPTport REFL1 REFL2 REFL12 TPORT FTREF1 RTREF2 | | no query |
| :CKIT | N50FEMALE N50MALE N75FEMALE N75MALE PC7 SMAFEMALE SMAMALE PC35FEMALE PC35MALE PC292FEMALE PC292MALE UFEMALE1 UMALE1 UFEMALE2 UMALE2 | | |
| :INSTall :N<50 75> | N50 N75 SMA PC7 PC35 PC292 USER1 USER2 | | |
| :SElect | <string> MMTHrough MFTHrough FFTHrough MMLINE1 MFLINE1 FFLINE1 MMLINE2 MFLINE2 FFLINE2 MMATten MFATten FFATten MMSNetwork MFSNetwork FFSNetwork MOPen FOPen MSHort FSHort MREFlect FRElect MMTCh FMTCh MSMatch FSMatch[,<string>] | | |
| [SENSe<1...4>] :CORRection :CKIT | | | |

| COMMAND | PARAMETER | UNIT | COMMENT |
|---------------------|--|----------------------------|---------|
| :USER<1 2> | MMTHrough MFTHrough FFTHrough MMLINE1 MFLINE1 FFLINE1 MMLINE2 MFLINE2 FFLINE2 MMATten MFATten FFATten MMSNetwork MFSNetwork FFSNetwork MOPen FOPen MSHort FSHort OSHort FOSHort MOShort MREFlect FREFlect MMTCh FMTCh MSMatch FSMatch[,<string>] | | |
| :SElect | <string> | | |
| :IMPedance | <numeric_value> | OHM | |
| :WGUide [:STATe] | <Boolean> | | |
| :CFRequency | <numeric_value> | HZ | |
| :MMTHrough | <string>, <string>, <numeric_value>, <numeric_value>, <numeric_value>, <numeric_value> | , , HZ, HZ, m, | |
| :MFTHrough | <string>, <string>, <numeric_value>, <numeric_value>, <numeric_value>, <numeric_value> | , , HZ, HZ, m, | |
| :FFTHrough | <string>, <string>, <numeric_value>, <numeric_value>, <numeric_value>, <numeric_value> | , , HZ, HZ, m, | |
| :MMLINE<1 2> | <string>, <string>, <numeric_value>, <numeric_value>, <numeric_value>, <numeric_value> | , , HZ, HZ, m, | |
| :MFLINE<1 2> | <string>, <string>, <numeric_value>, <numeric_value>, <numeric_value>, <numeric_value> | , , HZ, HZ, m, | |
| :FFLINE<1 2> | <string>, <string>, <numeric_value>, <numeric_value>, <numeric_value>, <numeric_value> | , , HZ, HZ, m, | |
| :MMATten | <string>, <string>, <numeric_value>, <numeric_value> | , , HZ, HZ | |
| :MFATten | <string>, <string>, <numeric_value>, <numeric_value> | , , HZ, HZ | |
| :FFATten | <string>, <string>, <numeric_value>, <numeric_value> | , , HZ, HZ | |

[SENSe[1...4]:]CORRection:CKIT:USER<1|2>:WGUIde[:STATe]

This command switches on or off waveguide calibration for the respective calibration kit. The suffix of SENSe has no meaning.

Syntax: [SENSe[1...4]:]CORRection:CKIT:USER<1|2>:WGUIde[:STATe] ON | OFF

Example: "CORR:CKIT:USER:WGU ON"

Features: *RST value: OFF
SCPI: device-specific

[SENSe[1...4]:]CORRection:CKIT:USER<1|2>:CFRequency

This command sets the cutoff frequency for the USER calibration kit.

Syntax: [SENSe[1...4]:]CORRection:CKIT:USER<1|2>:CFRequency <numeric_value>

Example: "CORR:CKIT:USER2:CFR 1 GHz"

Features: *RST value: 0 Hz
SCPI: device-specific

[SENSe[1...4]:]CORRection:DATA

This command is used for reading and writing system error correction values. The data set contains a complex value (real and imaginary component) for each test point. The data can be transmitted either in ASCII format, or in binary REAL32 format. Transmission in REAL64 format is not possible.

The <string> parameter may assume the following values:

| | |
|---------------------|---|
| "SCORR1" | Directivity, port 1 |
| "SCORR2" | Source match, port 1 |
| "SCORR3" | Reflection tracking, port 1 |
| "SCORR4" | Forward isolation |
| "SCORR5" | Load match, port 1 |
| "SCORR6" | Forward transmission tracking |
| "SCORR7" | Directivity, port 2 |
| "SCORR8" | Source match, port 2 |
| "SCORR9" | Reflection tracking, port 2 |
| "SCORR10" | Reverse isolation |
| "SCORR11" | Load match, port 2 |
| "SCORR12" | Reverse transmission tracking |
| "E11" to "E22" | Elements of E matrix (15-term method) |
| "G11" to "G22" | Elements of G matrix (7-term and 15-term methods) |
| "H11" to "H22" | Elements of H matrix (7-term and 15-term methods) |
| "F11", "F21", "F12" | Elements of F matrix (15-term method) |

Syntax: [SENSe[1...4]:]CORRection:DATA <string>,<block> | <numeric_value>...

Example: "CORR:DATA "SCORR1" ,<block_data>"

Features: *RST value: -
SCPI: device-specific

The table below shows the correction terms available for the calibration methods:

| Calibration Method | Available Correction Terms |
|--|---|
| Trans Norm Forward Trans Norm Reverse | SCORR6 SCORR12 |
| Trans Norm both Directions | SCORR6, SCORR12 |
| Refl Norm P1 Refl Norm P2 | SCORR3 SCORR9 |
| Refl Norm both Ports | SCORR3, SCORR9 |
| Trans+Refl Norm Forward Trans+Refl Norm Reverse | SCORR3, SCORR6 SCORR9, SCORR12 |
| Trans+Refl Norm both Ports | SCORR3, SCORR6, SCORR9, SCORR12 |
| Full One Port P1 Full One Port P2 | SCORR1 to SCORR3 SCORR7 to SCORR9 |
| Full One Port both Ports | SCORR1 to SCORR3, SCORR7 to SCORR9 |
| One Path Two Port Forward One Path Two Port Reverse | SCORR1 to SCORR3, SCORR6 SCORR7 to SCORR9, SCORR12 |
| TOM, TRM, TNA, TRL | G11 to G22 and H11, H12, H22 (H21 = 1); Gxx is normalized to H21 |
| TOSM | SCORR1 to SCORR12 |
| TOM-X | E11 to E22, G11 to G22, H11 to H22, F11, F21, F12 |

[SENSe[1...4]:]CORRection:POWer:DATA

This command is used for reading and writing power correction values for a receiver channel. The data can be transmitted either in ASCII format, or in binary REAL32 format. Transmission in REAL64 format is not possible.

The <string> parameter may assume the following values:

| | |
|-----------|---|
| "B1" | Correction data for wave b1 at port 1 |
| "INPUTB1" | Correction data for wave b1 at input b1 |
| "B2" | Correction data for wave b2 at port 2 |
| "INPUTB2" | Correction data for wave b2 at input b2 |
| "IFREF" | Correction data for reference input a1 on rear panel |
| "A1REF" | Correction data for reference input a1 (ZVM and ZVK only) |
| "A2REF" | Correction data for reference input a2 (ZVM and ZVK only) |

Syntax: [SENSe[1...4]:]CORRection:POWer:DATA <string>,<block> | <numeric_value>...

Example: "CORR:POW:DATA "B1" ,<block>"

Features: *RST value: -
SCPI: device-specific

SOURce Subsystem (Re section 3.6.15)

| COMMAND | PARAMETER | UNIT | COMMENT |
|----------------|---|-----------------|----------|
| SOURce<1...4> | | | |
| :POWer | | | |
| [:LEVel] | | | |
| [:IMMediate] | | | |
| [:AMPLitude] | <numeric_value> | DBM | |
| :CAMPlitude | | | |
| :A<1 2> | <numeric_value> | DBM | |
| :ESRC<1 2> | <numeric_value> | DBM | |
| :SLOPe | <numeric_value> | DB/GHZ | |
| :EXTernal<1 2> | | | |
| [:AMPLitude] | <numeric_value> | DBM | |
| :SLOPe | <numeric_value> | DB/GHZ | |
| :ALC | | | |
| [:STATe] | <Boolean> | | |
| :NLINear | | | |
| :COMP | | | |
| :RANGe | | | |
| :UPPer | <numeric_value> | dBm | |
| :LOWer | <numeric_value> | dBm | |
| :SOI | | | |
| :RANGe | | | |
| :UPPer | <numeric_value> | dBm | |
| :LOWer | <numeric_value> | dBm | |
| :TOI | | | |
| :RANGe | | | |
| :UPPer | <numeric_value> | dBm | |
| :LOWer | <numeric_value> | dBm | |
| :CENTer | <numeric_value> | dBm | |
| :SPAN | <numeric_value> | dB | |
| :START | <numeric_value> | dBm | |
| :STOP | <numeric_value> | dBm | |
| :CORRection | | | |
| :DATA | <string>, <block> <numeric_value>... | | |
| :EXT<1 2> | | | |
| :SWEep | <numeric_value>, <numeric_value>, <numeric_value>, LIN LOG | HZ, HZ, , | |
| :NREadings | <numeric_value> | | |
| [:ACQuire] | A1 A2 ESRC1 ESRC2 | | no query |
| :LLISt | <numeric_value>, <numeric_value>, <numeric_value> ... | , HZ, dB | |
| :STATE | <Boolean> | | |

| COMMAND | PARAMETER | UNIT | COMMENT |
|------------------|--|--------------------|---------|
| :FREQuency | | | |
| [:CW] | <numeric_value> | HZ | |
| :FIXED | <numeric_value> | HZ | |
| :CONVersion | | | |
| :ARbitrary | | | |
| :IFRequency | <numeric_value>, <numeric_value>, <numeric_value>, CW FIXed SWEEp | , , HZ, | |
| :EFRequency<1 2> | <Boolean>, <numeric_value>, <numeric_value>, <numeric_value>, CW FIXed SWEEp | , , , HZ, | |
| :NLINear | | | |
| :COMP | INT ESRC1 ESRC2 | | |
| :SOI | IESRC1 IESRC2 ESRC12 | | |
| :OFFSet | <numeric_value> | HZ | |
| :TOI | IESRC1 IESRC2 ESRC12 | | |
| :OFFSet | <numeric_value> | HZ | |

SOURce[1...4]:POWER:CORRection:DATA

This command is used for reading and writing power correction values for a generator channel. The data can be transmitted either in ASCII format, or in binary REAL32 format. Transmission in REAL64 format is not possible.

The <string> parameter is used for selecting the correction data set as follows:

| | |
|---------|----------------------|
| "A1" | Generator output a1 |
| "A2" | Generator output a2 |
| "ESRC1" | External generator 1 |
| "ESRC2" | External generator 2 |

Syntax: SOURce[1...4]:POWER:CORRection:DATA <string>,
<block> | <numeric_value>...

Example: "SOUR:POW:CORR:DATA "A1" ,<block>"

Features: *RST value: -
SCPI: device-specific

6 Special Features

The format of the system error calibration (SFK) files and the calibration kit (CalKit) files was changed for version 3.50. The files from older firmware versions are therefore converted to the new data format. The change concerns files with the extension "CAC", "CA1" to "CA4", "CK", "CKD" and "DAT". The old files are not deleted but renamed, i.e. an additional extension – ".BC350" – is appended. For example, "FACTORY.CAC" is renamed to "FACTORY.CAC.BC350".

Note:

There is no conversion if version 3.50 is updated to version 3.52.

The new data format cannot be processed by older firmware versions.

The following procedure should be adopted, therefore, when restoring a previous firmware version (e.g. V 3.40):

- Restore the old firmware version as usual by means of SETUP → FIRMWARE UPDATE → RESTORE.
- Terminate the firmware.
- In the Explorer, change to the "C:\R_S\INSTR\CAL" directory.
- Each file for which a file of identical name but with the additional extension ".BC350" exists, must be renamed, for example by appending the additional extension ".V350". For example, "N50.CKD" must be renamed to "N50.CKD.V350".

Note:

If a file with the name "CK_INST.DAT" exists, it must in any case be renamed to "CK_INST.DAT.V350", no matter whether or not a file "CK_INST.DAT.BC350" exists.

- All files with the additional extension ".BC350" must be renamed, i.e. the extension has to be removed. For example, "N50.CKD.BC350" has to be renamed to "N50.CKD".
- Start the firmware by means of START → START INSTRUMENT. The SFK and CalKit files that were available prior to the update to version 3.50 or 3.52 are now fully available again. New files added through the version 3.50 or 3.52 update cannot be used however.

As an alternative to the above procedure, the complete "C:\R_S\INSTR\CAL" directory can be saved, for example under "C:\R_S\INSTR\CAL.BC350", before the update to version 3.50 or 3.52 is made. After restoring the old firmware version, this directory must be renamed to "C:\R_S\INSTR\CAL".

Contents

| | |
|---|------|
| 1 Preparation for Use | 1.1 |
| 1.1 Introduction | 1.1 |
| 1.2 Legend for Front and Rear View | 1.1 |
| 1.2.1 Front View ZVR, ZVK and ZVM..... | 1.1 |
| 1.2.1.1 Front View ZVR | 1.1 |
| 1.2.1.2 Front View ZVK, ZVM..... | 1.13 |
| 1.2.2 Rear View ZVR, ZVK and ZVM | 1.15 |
| 1.3 Start-Up | 1.20 |
| 1.3.1 Unpacking the Instrument | 1.20 |
| 1.3.2 Instrument Setup | 1.20 |
| 1.3.2.1 Stand-alone Operation | 1.20 |
| 1.3.2.2 19" Rack Installation..... | 1.21 |
| 1.3.3 EMI Protection Measures | 1.21 |
| 1.3.4 Connecting to AC Power | 1.21 |
| 1.3.5 AC Power Line Fuses..... | 1.21 |
| 1.3.6 Battery-Powered Memory..... | 1.22 |
| 1.4 Controller Function | 1.23 |
| 1.5 Connecting a Mouse | 1.25 |
| 1.6 Connecting an External Keyboard | 1.25 |
| 1.7 Connecting an External Monitor | 1.26 |
| 1.8 Connecting an Output Device | 1.28 |
| 1.9 Connecting a CD-ROM Drive | 1.35 |
| 1.10 Firmware Update | 1.37 |
| 1.11 Installing Windows NT Software | 1.38 |
| 1.12 Options | 1.39 |
| 1.12.1 Option FSE-B17 – Third IEC/IEEE Interface..... | 1.39 |
| 1.12.1.1 Installing the software..... | 1.39 |
| 1.12.1.2 Operation..... | 1.42 |
| 1.12.2 Option FSE-B16 – Ethernet Adapter | 1.43 |
| 1.12.2.1 Hardware Installation..... | 1.43 |
| 1.12.2.2 Software Installation | 1.44 |
| 1.12.2.3 Operation..... | 1.48 |

| | |
|---|------|
| 2 Manual Operation | 2.1 |
| 2.1 Introduction: Measurement Examples and Processing of Measured Values | 2.1 |
| 2.1.1 Transmission Measurements – Measurement of Gain and Loss..... | 2.2 |
| 2.1.1.1 Measurement Task..... | 2.2 |
| 2.1.1.2 Connection of the DUT | 2.2 |
| 2.1.1.3 Preset | 2.2 |
| 2.1.1.4 Setting the Analyzer..... | 2.3 |
| 2.1.1.5 Instrument Calibration | 2.8 |
| 2.1.1.6 Performing the Measurement..... | 2.9 |
| 2.1.1.7 Output of Measurement Results..... | 2.11 |
| 2.1.2 Reflection Measurements..... | 2.12 |
| 2.1.2.1 Measurement Task..... | 2.12 |
| 2.1.2.2 Connection of the DUT | 2.12 |
| 2.1.2.3 Preset | 2.12 |
| 2.1.2.4 Setting the Analyzer..... | 2.12 |
| 2.1.2.5 Instrument Calibration | 2.13 |
| 2.1.2.6 Performing the Measurement..... | 2.14 |
| 2.1.3 Filter Measurements – Measurements of Bandwidth, Q Factor and Shape Factor.... | 2.17 |
| 2.1.3.1 Measurement Task..... | 2.17 |
| 2.1.3.2 Reset, Setting and Calibration of the Instrument..... | 2.17 |
| 2.1.3.3 Measurement of the Filter Parameters..... | 2.17 |
| 2.1.4 Processing of Measured Values..... | 2.22 |
| 2.2 Menu Overview | 2.25 |
| 2.2.1 SYSTEM Key Group..... | 2.25 |
| 2.2.2 COPY Key Group | 2.29 |
| 2.2.3 MEMORY Key Group | 2.30 |
| 2.2.4 USER Key | 2.32 |
| 2.2.5 SWEEP Key Group | 2.33 |
| 2.2.6 MARKER Key Group..... | 2.35 |
| 2.2.7 LINES Key Group..... | 2.37 |
| 2.2.8 RESPONSE Key Group | 2.38 |
| 2.2.9 CAL Key Group | 2.41 |
| 2.3 Basic Steps of Operation | 2.48 |
| 2.3.1 Screen | 2.48 |
| 2.3.1.1 The Diagram Area | 2.49 |
| 2.3.1.2 The Softkey Area..... | 2.59 |
| 2.3.2 Subdivision of Screen - Display Modes | 2.60 |
| 2.3.2.1 Single Channel | 2.60 |
| 2.3.2.2 Dual Channel Overlay Overlay | 2.61 |
| 2.3.2.3 Dual Channel Split..... | 2.61 |
| 2.3.2.4 Quad Channel Overlay | 2.62 |
| 2.3.2.5 Quad Channel Dual Split..... | 2.62 |

| | |
|---|-------------|
| 2.3.2.6 Quad Channel Quad Split..... | 2.63 |
| 2.3.2.7 Full Screen – Expand Mode | 2.63 |
| 2.3.3 Diagrams | 2.64 |
| 2.3.3.1 Cartesian Diagrams..... | 2.64 |
| 2.3.3.2 Polar Diagrams..... | 2.68 |
| 2.3.3.3 Smith Charts..... | 2.71 |
| 2.3.3.4 Inverted Smith Charts..... | 2.72 |
| 2.3.3.5 Charter Diagrams | 2.72 |
| 2.3.4 Display Windows | 2.73 |
| 2.3.4.1 Message Fields | 2.73 |
| 2.3.4.2 Markers and Marker Info Lists..... | 2.73 |
| 2.3.4.3 System Messages | 2.76 |
| 2.3.4.4 Scale Reference Fields | 2.77 |
| 2.3.5 Calling and Changing the Menus | 2.79 |
| 2.3.6 Setting the Parameters..... | 2.81 |
| 2.3.6.1 Numeric Keypad – <i>DATA ENTRY</i> Key Group | 2.81 |
| 2.3.6.2 Roll-key and Cursor Keys..... | 2.82 |
| 2.3.6.3 Selection of Parameters | 2.83 |
| 2.3.6.4 Editing of Numeric Parameters | 2.88 |
| 2.3.6.4.1 Editing With External Keyboard..... | 2.91 |
| 2.3.6.4.2 Editing with Auxiliary Line Editor..... | 2.92 |
| 2.3.7 Disabling the Control Elements - <i>HOLD</i> Key..... | 2.93 |
| 2.3.8 Setting the Step size - <i>STEP</i> Key..... | 2.94 |
| 2.3.9 Mouse and External Keyboard Control..... | 2.95 |
| 2.3.9.1 External Keyboard | 2.95 |
| 2.3.9.2 Mouse Control of Data Entry Windows and Tables..... | 2.95 |
| 2.3.9.3 Mouse Control of Display Elements | 2.96 |
| 2.4 General Configuration – <i>SYSTEM</i> Key Group | 2.97 |
| 2.4.1 Selection of the Operating Mode – <i>MODE</i> Key..... | 2.97 |
| 2.4.1.1 Time Domain Transformation (Option ZVR-B2)..... | 2.98 |
| 2.4.1.1.1 Switchover between Frequency and Time Domain | 2.99 |
| 2.4.1.1.2 Selecting the Gate | 2.99 |
| 2.4.1.1.3 Selecting the Transformation Type..... | 2.106 |
| 2.4.1.1.4 Defining the frequency grid..... | 2.108 |
| 2.4.1.1.5 Scaling the Abscissa | 2.113 |
| 2.4.1.1.6 Positioning the Gate | 2.114 |
| 2.4.1.2 External Measurements..... | 2.115 |
| 2.4.1.3 Measurements on Frequency-Converting DUTs (Option ZVR-B4) | 2.117 |
| 2.4.1.3.1 Harmonics Measurements | 2.118 |
| 2.4.1.3.2 Mixer Measurements..... | 2.119 |
| 2.4.1.3.3 Arbitrary Frequency Conversion | 2.123 |
| 2.4.1.4 Nonlinear Measurements (Option ZVR-B5) | 2.126 |
| 2.4.1.4.1 Compression Point Measurement..... | 2.127 |
| 2.4.1.4.2 Measurement of the 2 nd and 3 rd Order Interc. Point (SOI, TOI).. | 2.132 |
| 2.4.1.5 Sweep Modes..... | 2.138 |
| 2.4.1.6 Reference Channel Ports (Option ZVR-B6) | 2.140 |
| 2.4.1.7 Fast Measurement (<i>FAST MODE</i>) | 2.140 |
| 2.4.2 Preliminary Setup and Interface Configuration – <i>SETUP</i> Key..... | 2.141 |
| 2.4.2.1 Programming the Interface Configuration and Time | 2.142 |

| | | |
|-------------|--|--------------|
| 2.4.2.1.1 | IEC Bus Address Selection | 2.142 |
| 2.4.2.1.2 | User Port Configuration | 2.143 |
| 2.4.2.1.3 | Serial Interface Configuration | 2.144 |
| 2.4.2.1.4 | Setting Date and Time..... | 2.147 |
| 2.4.2.1.5 | Connecting the External Monitor | 2.147 |
| 2.4.2.1.6 | Indication of the Automatic System Error Calibration | 2.148 |
| 2.4.2.2 | External Reference Oscillator..... | 2.148 |
| 2.4.2.3 | Enabling Firmware Options | 2.149 |
| 2.4.2.4 | Service Functions | 2.150 |
| 2.4.3 | Instrument Status and Measurement Parameters – INFO Key..... | 2.151 |
| 2.4.3.1 | Firmware Versions..... | 2.151 |
| 2.4.3.2 | Hardware Configuration and Options | 2.152 |
| 2.4.3.3 | System Messages | 2.153 |
| 2.5 | Measurement Documentation – COPY Key Group | 2.155 |
| 2.5.1 | Printing Data – COPY Key | 2.155 |
| 2.5.2 | Printing Configuration – SETTING Key | 2.157 |
| 2.5.2.1 | Selection of Displayed Elements | 2.158 |
| 2.5.2.2 | Selection of Data Medium | 2.159 |
| 2.5.2.3 | Selection of Hardcopy Format..... | 2.159 |
| 2.5.2.4 | Entry of Comment Text | 2.160 |
| 2.5.2.5 | Color Settings..... | 2.161 |
| 2.5.2.6 | Selection and Configuration of the Output Device..... | 2.162 |
| 2.5.2.7 | Selection of Line Style | 2.164 |
| 2.6 | Saving and Recalling Data Sets – MEMORY Key Group..... | 2.165 |
| 2.6.1 | Configuration of Memory – CONFIG Key..... | 2.167 |
| 2.6.2 | Saving Data Sets – SAVE Key..... | 2.169 |
| 2.6.2.1 | Selecting the Data Set for Storage | 2.170 |
| 2.6.2.2 | Selecting the Data Subset for Storage | 2.172 |
| 2.6.2.3 | Configuration of ASCII Files | 2.173 |
| 2.6.3 | Recalling Data Sets – RECALL Key..... | 2.177 |
| 2.6.3.1 | Selecting the Data Set to be Recalled..... | 2.178 |
| 2.6.3.2 | Selecting Data Subsets to be Recalled | 2.180 |
| 2.7 | Switchover to Manual Operation and Default Setup – STATUS Group | 2.182 |
| 2.7.1 | Switchover to Manual Operation – LOCAL Key | 2.182 |
| 2.7.2 | Default Setup – PRESET Key | 2.183 |
| 2.8 | Macros – USER Key | 2.185 |
| 2.8.1 | Fundamentals..... | 2.185 |
| 2.8.2 | Starting Macros | 2.186 |
| 2.8.3 | Defining Macros | 2.187 |
| 2.9 | Defining the Sweep Range – STIMULUS Key Group..... | 2.189 |
| 2.10 | Sweep Setup – SWEEP Key Group..... | 2.191 |
| 2.10.1 | Settings for the Sweep Variable – SWEEP Key..... | 2.191 |
| 2.10.1.1 | Single Point Measurement | 2.192 |

| | | |
|-------------|---|--------------|
| 2.10.1.2 | Defining the grid | 2.193 |
| 2.10.1.3 | Defining the Number of Points..... | 2.199 |
| 2.10.1.4 | Setting the Trigger Mode | 2.200 |
| 2.10.1.5 | Automatic or Manual Setting of the Sweep Time | 2.203 |
| 2.10.1.6 | Coupling of Display Channels..... | 2.204 |
| 2.10.1.7 | Miscellaneous Settings..... | 2.205 |
| 2.10.2 | Starting a New Sweep – <i>RESTART</i> Key | 2.206 |
| 2.10.3 | Setting Fixed Sweep Parameters – <i>SOURCE</i> Key | 2.207 |
| 2.10.4 | Setting the Averaging Function and the Receiver Bandwidth – <i>AVG</i> Key..... | 2.212 |
| 2.11 | The Marker Functions – <i>MARKER</i> Key Group..... | 2.215 |
| 2.11.1 | Main Markers – <i>MARKER</i> Key | 2.215 |
| 2.11.1.1 | Switching on and Moving Markers..... | 2.217 |
| 2.11.1.2 | Conversion of the Marker Value | 2.218 |
| 2.11.1.3 | Format of the Marker Value..... | 2.219 |
| 2.11.1.4 | Info list and Interpolation | 2.222 |
| 2.11.2 | Marker Search Functions – <i>SEARCH</i> Key | 2.223 |
| 2.11.3 | Delta Markers – <i>DELTA</i> Key | 2.227 |
| 2.11.4 | Marker Assignment Functions – = <i>MKR</i> Key | 2.229 |
| 2.12 | Display and Limit Lines – <i>LINES</i> Key Group | 2.231 |
| 2.12.1 | Display Lines – <i>LINES</i> Key..... | 2.231 |
| 2.12.2 | Limit Lines – <i>LIMITS</i> Key | 2.233 |
| 2.12.2.1 | Selecting and Switching On Limit Lines | 2.234 |
| 2.12.2.2 | Defining a Limit Line in a Circular Diagram | 2.236 |
| 2.12.2.3 | Defining a Limit Line in a Cartesian Diagram | 2.238 |
| 2.12.2.4 | Moving a Limit Line..... | 2.242 |
| 2.12.2.5 | Display and Limit Check | 2.244 |
| 2.13 | Selection of Display Channel – <i>CHANNEL</i> Group..... | 2.245 |
| 2.14 | Configuring of Measured-Value Display – <i>RESPONSE</i> Key Group..... | 2.247 |
| 2.14.1 | Selection of the Measured Quantity – <i>MEAS</i> Key | 2.247 |
| 2.14.1.1 | Measurement of S-Parameters | 2.248 |
| 2.14.1.2 | Measuring Wave Quantities | 2.252 |
| 2.14.1.3 | Measuring Ratios of Wave Quantities | 2.255 |
| 2.14.1.4 | Measurement of Two-Port Z or Y Parameters | 2.258 |
| 2.14.1.5 | Converting the Measured Quantity | 2.261 |
| 2.14.1.6 | Measurement of Stability Factors | 2.263 |
| 2.14.1.7 | Measuring DC Voltage | 2.264 |
| 2.14.2 | Formatting of the Measured Quantity – <i>FORMAT</i> Key..... | 2.265 |
| 2.14.3 | Scaling of the Test Diagram – <i>SCALE</i> Key | 2.272 |
| 2.14.4 | Selection of the Test Diagram – <i>DIAGRAM</i> Key | 2.277 |
| 2.14.4.1 | Defining the Cartesian Segmentation of the y Axis | 2.279 |
| 2.14.4.2 | Defining the Polar Radial Segmentation..... | 2.283 |
| 2.14.5 | Configuration of the Screen – <i>DISPLAY</i> Key | 2.285 |
| 2.14.5.1 | Defining the Number and Arrangement of the Display Channels..... | 2.285 |

| | | |
|-------------|--|--------------|
| 2.14.5.2 | Expansion of Diagrams to Maximum Screen Format..... | 2.286 |
| 2.14.5.3 | Configuring the Graphic Elements of the Display..... | 2.287 |
| 2.14.6 | Operations with Traces – <i>TRACE</i> Key..... | 2.292 |
| 2.15 | Correction of System Errors – <i>CAL</i> Key Group..... | 2.298 |
| 2.15.1 | Calibration – <i>CAL</i> Key..... | 2.298 |
| 2.15.1.1 | System Error Calibration..... | 2.299 |
| 2.15.1.1.1 | Performing a System-Error Calibration..... | 2.300 |
| | a) Specification of the Connectors at the Test Ports..... | 2.301 |
| | b) System-Error Calibration Procedure..... | 2.303 |
| 2.15.1.1.2 | Full Two-port Calibration (ZVR, ZVC, ZVK and ZVM)..... | 2.305 |
| | a) TOM Calibration Procedure..... | 2.305 |
| | b) TRM Calibration Procedure..... | 2.307 |
| | c) TRL Calibration Procedure..... | 2.309 |
| | d) TNA calibration procedure..... | 2.311 |
| | e) TOSM calibration procedure..... | 2.312 |
| | f) TOM-X calibration procedure..... | 2.314 |
| | g) AutoKal fundamental calibration..... | 2.315 |
| 2.15.1.1.3 | Full two-port calibration (ZVRE, ZVCE)..... | 2.317 |
| | a) TOSM calibration..... | 2.318 |
| | b) AutoKal Fundamental Calibration..... | 2.320 |
| 2.15.1.1.4 | Automatic Two-port Transfer Calibration..... | 2.320 |
| 2.15.1.1.5 | Full One-port Calibr. (ZVR, ZVRE; ZVC, ZVCE, ZVK, ZVM)..... | 2.324 |
| 2.15.1.1.6 | Full One-port Calibration (ZVRL)..... | 2.327 |
| 2.15.1.1.7 | Unidir. Two-port Calibr. (ZVR, ZVRE, ZVC, ZVCE, ZVK, ZVM) .. | 2.328 |
| 2.15.1.1.8 | Unidirectional Two-port Calibration (ZVRL)..... | 2.331 |
| 2.15.1.1.9 | AutoKal Fundamental Calibration (ZVRL)..... | 2.332 |
| 2.15.1.1.10 | Normalization Calibr. (ZVR, ZVRE, ZVC, ZVCE, ZVK, ZVM)..... | 2.333 |
| | a) Transmission Normalization..... | 2.333 |
| | b) Reflection Normalization..... | 2.334 |
| | c) Combined Transmission and Reflection Normalization..... | 2.336 |
| 2.15.1.1.11 | Normalization Calibration (ZVRL)..... | 2.338 |
| | a) Transmission Normalization..... | 2.338 |
| | b) Reflection Normalization..... | 2.339 |
| | c) Combined Transmission and Reflection Normalization..... | 2.340 |
| 2.15.1.2 | Auxiliary Functions for System Error Calibration..... | 2.341 |
| 2.15.1.3 | Characteristics of Calibration Standards..... | 2.343 |
| 2.15.1.4 | Power Calibration (Option ZVR-B7)..... | 2.355 |
| 2.15.2 | Entry of Offset Parameters – <i>OFFSET</i> Key..... | 2.371 |

Figures

| | |
|--|--------------------------|
| Fig. 1-1 Front view ZVR | 1.2; 1.4; 1.6; 1.8; 1.10 |
| Fig. 1-1 Front view ZVK, ZVM..... | 1.12 |
| Fig. 1-2 Rear View | 1.14, 1.16; 1.18 |
| Fig. 2-1 Measurement display screen with an autoscaled trace..... | 2.5 |
| Fig. 2-2 Measurement display screen after manual scaling | 2.7 |
| Fig. 2-3 Display of magnitude in cartesian coordinates | 2.9 |
| Fig. 2-4 Display of phase in cartesian coordinates | 2.10 |
| Fig. 2-5 Display of magnitude in cartesian coordinates | 2.14 |
| Fig. 2-6 Display of phase in cartesian coordinates | 2.15 |
| Fig. 2-7 Display of the reflection coefficient in the Smith diagram | 2.16 |
| Fig. 2-8 Determination of the 3 dB bandwidth of a bandpass | 2.19 |
| Fig. 2-9 Determination of the Q-factor | 2.20 |
| Fig. 2-10 Shape factor 60 dB/3 dB..... | 2.21 |
| Fig. 2-11 Process. sequence of measured values for a ZVR display channel in bidirect. operation... | 2.22 |
| Fig. 2-12 General setup of the screen | 2.48 |
| Fig. 2-13 Diagram area..... | 2.49 |
| Fig. 2-14 Linear, Cartesian diagram | 2.64 |
| Fig. 2-15 Cartesian diagram with two segments on the abscissa and ordinate (single channel), each with limit lines and FAIL message | 2.65 |
| Fig. 2-16 Logarithmic Cartesian diagram with symmetric subdivision for pos. and neg. values | 2.67 |
| Fig. 2-17 Linear polar diagram (single channel) | 2.68 |
| Fig. 2-18 Lin./ log. polar diagram with 2 segments (Single Channel) | 2.70 |
| Fig. 2-19 Smith chart | 2.71 |
| Fig. 2-20 Example of a charter diagram | 2.72 |
| Fig. 2-21 Configuration of mixer measurements - <i>DEF MIXER MEAS</i> menu | 2.119 |
| Fig. 2-22 Configuration of system frequencies | 2.123 |
| Fig. 2-23 Setting general parameters of the instrument | 2.142 |
| Fig. 2-24 Setting the parameters for external interfaces | 2.144 |
| Fig. 2-25 Enabling firmware options | 2.149 |
| Fig. 2-26 System messages | 2.154 |
| Fig. 2-27 Configuration of the output device..... | 2.162 |
| Fig. 2-28 File and storage media management..... | 2.167 |
| Fig. 2-29 Saving data sets | 2.169 |
| Fig. 2-30 Selecting the data set for storage..... | 2.172 |
| Fig. 2-31 Recalling data sets | 2.178 |

| | |
|---|-------|
| Fig. 2-32 Selecting partial data sets to be recalled | 2.180 |
| Fig. 2-33 Editing the segment list..... | 2.194 |
| Fig. 2-34 Selection of limit lines | 2.234 |
| Fig. 2-35 Defining a limit line in a Cartesian diagram | 2.239 |
| Fig. 2-36 Defining the Cartesian Segmentation of the y Axis | 2.280 |
| Fig. 2-37 Defining the Polar Radial Segmentation..... | 2.283 |
| Fig. 2-38 Setting the screen colors | 2.288 |
| Fig. 2-39 Menu CONFIG AUTOKAL..... | 2.322 |
| Fig. 2-40 Selecting the connector families..... | 2.344 |
| Fig. 2-41 Modifying the standards..... | 2.348 |
| Fig. 2-42 Entry of a frequency-dependent calibration factor | 2.366 |
| Fig. 2-43 Entry of a frequency-dependent loss | 2.370 |

Tables

Table 1-1 Factory settings for *DEVICE 1* and *2* in the *HARDCOPY-DEVICE SETTINGS* menu..... 1.29

Table 2-1 Overview of the most important PRESET settings 2.1

Table 2-2 Relationship between file extensions and contents of partial data sets 2.166

Table 2-3 PRESET settings..... 2.183

Table 2-4 Input parameters of the *START*, *STOP*, *CENTER* and *SPAN* key..... 2.189

Index

Note: All softkeys are listed with their names. The page numbers 2.xxx refer to the detailed description of the softkeys in chapter 2. Generally, the number of the page in chapter 3 containing the equivalent remote control command is given in addition.

A list of softkeys and equivalent remote control commands or command sequences is given in section 3.9.

Annex C contains a list of all remote control commands.

| | | |
|--|---------------------------|--|
| = | | |
| = MKR (key) | 2.229 | |
| 0 | | |
| 0...9 (key) | 2.81 | |
| 1 | | |
| 1 Hz, ..., 10 kHz (softkeys)..... | 2.214, 3.77 | |
| 1/S..... | 2.219, 2.262, 3.31, 3.40 | |
| 5 | | |
| 51, ..., 1601 (softkeys)..... | 2.199, 3.113 | |
| A | | |
| a1 INPUT POWER CAL | 2.364 | |
| a1, ..., b2 | 2.253, 3.107 | |
| Abort | | |
| macro | 2.182 | |
| Abscissa scaling | | |
| time domain transformation | 2.113 | |
| ACCEPT POSITION..... | 2.237, 2.240 | |
| Accessories | | |
| ZVC, ZVCE | 5.52 | |
| ZVR, ZVRE, ZVRL | 5.1 | |
| ACTIVATE KIT | 2.347 | |
| ACTIVE XX STANDARDS (selection table)..... | 2.344 | |
| ACTIVE XX YY (menu table) | 2.350 | |
| ADD CONSTANT | 2.274, 3.50 | |
| Administrator identification..... | 1.23 | |
| Admittance | 2.261 | |
| absolute..... | 2.261 | |
| normalized..... | 2.261 | |
| reference..... | 2.261 | |
| serial | 2.261 | |
| terminating..... | 2.261 | |
| ALL MARKER OFF..... | 2.222, 3.30 | |
| Amplitude offset..... | 2.372 | |
| Analyzer Monitor | | |
| Connector..... | A.25 | |
| Aperture | | |
| group delay..... | 2.267 | |
| APPEND NEW | 3.53 | |
| APPEND NEW | 2.174 | |
| APPLY CAL..... | 2.307, 2.308, 2.310, 3.93 | |
| APPLY CAL (FULL ONE PORT)..... | 2.326, 3.93 | |
| APPLY CAL (FULL ONE PORT, ZVRL)..... | 2.328, 3.93 | |
| APPLY CAL (ONE PATH, ZVR) | 2.330, 3.93 | |
| APPLY CAL (ONE PATH, ZVRL) | 2.332, 3.93 | |
| APPLY CAL (REFL NORM, ZVR)..... | 2.335, 3.93 | |
| APPLY CAL (REFL NORM, ZVRL)..... | 2.339, 3.93 | |
| APPLY CAL (TNA) | 2.312 | |
| APPLY CAL (TOM-X)..... | 2.315, 3.93 | |
| APPLY CAL (TOSM)..... | 2.313, 3.93 | |
| APPLY CAL (TOSM, ZVRE) | 2.319, 3.93 | |
| APPLY CAL (TRANS AND REFL NORM, ZVR) | 2.337, 3.93 | |
| APPLY CAL (TRANS AND REFL NORM, ZVRL) | 2.340, 3.93 | |
| APPLY CAL (TRANS NORM, ZVR) | 2.334, 3.93 | |
| APPLY CAL (TRANS NORM, ZVRL) | 2.338, 3.93 | |
| APPLY CAL(TNA)..... | 3.93 | |
| ARBITRARY | 2.199, 3.113 | |
| ARBITRARY (mixer measurements) | 2.123, 3.104 | |
| ARBITRARY GATE SHAPE..... | 2.103, 3.21 | |
| ARBITRARY SIDELOBES | 2.112, 3.42 | |
| ARBITRARY SYST FREQ (mixer measurements) | 2.124, 3.104, 3.121 | |
| ARBITRARY SYSTEM FREQUENCIES (selection table) | 2.123 | |
| ASCII | 2.173, 3.53 | |
| ASCII file | | |
| create..... | 2.173 | |
| define output format | 2.173 | |
| ASCII FILES..... | 2.173 | |
| ATTEN | 2.312, 3.92 | |
| Attenuator | 2.209 | |
| AUI connector | 1.44 | |
| AUTO LENGTH (OFFSET) | 2.373, 3.97 | |
| AUTO RECALL | 2.179 | |
| AUTOKAL | | |
| indicate | 2.148 | |
| AUTOKAL CONNECTED..... | 2.148 | |
| AUTOKAL FUNDAM TAL | 3.93 | |
| AUTOKAL FUNDAM TAL (ZVRE)..... | 3.93 | |
| AUTOKAL FUNDAM TAL (ZVRL)..... | 2.332, 3.93 | |
| AUTOSCALE | 2.273, 3.47 | |
| Auxiliary line editor..... | 2.92 | |
| AVERAGE..... | 2.212, 3.76 | |
| AVERAGE RESTART | 2.213, 3.76 | |
| Averaging..... | 2.212 | |
| Averaging factor..... | 2.213 | |
| AVG (key) | 2.212 | |
| AVG FACTOR..... | 2.213, 3.76 | |
| AVG TYPE SWEEP POINT | 2.213, 3.77 | |
| B | | |
| b1/a1, ... b2/a2 | 2.256, 3.107 | |
| BACK (key) | 2.81 | |
| Bandfilter measurements..... | 2.225 | |
| BANDFILTER MODE | 2.224, 3.33 | |
| BANDPASS | 2.225, 3.33 | |
| Band-pass filter | 2.225 | |
| BANDPASS LOWPASS..... | 2.108, 3.41 | |
| BANDSTOP | 2.225, 3.33 | |
| Band-stop filter..... | 2.225 | |
| BNC connector..... | 1.43 | |
| BOTH PORTS..... | 2.324, 3.93 | |

| | |
|---|--|
| BOTH PORTS (REFL NORM, ZVR)..... | 2.335, 3.93 |
| BRIGHTNESS | 2.288 |
| Broadband termination..... | 2.304 |
| C | |
| C..... | 2.221, 2.268, 3.22 |
| CAL | 2.176, 3.54 |
| CAL (key group) | 2.298 |
| CAL (key) | 2.298 |
| CAL a1 POWER..... | 2.209, 2.363, 3.116 |
| CAL a2 POWER..... | 2.209, 2.363, 3.116 |
| CAL b1 INPUT POWER | 2.364 |
| CAL b1 POWER..... | 2.364 |
| CAL EXT SRC1 POWER..... | 2.211, 3.116 |
| CAL EXT SRC2 POWER..... | 2.211, 3.116 |
| CAL INTERPOL..... | 2.342, 3.92 |
| CAL KITS | 3.93 |
| CALEXT SRC 1 POWER..... | 2.368 |
| Calibration | 2.298 |
| full one-port | 2.327 |
| full two-port..... | 2.305 |
| full two-port (ZVRE)..... | 2.317 |
| fundamental (ZVRL) | 2.332 |
| interpolation..... | 2.342 |
| normalization (ZVR)..... | 2.333 |
| normalization (ZVRL)..... | 2.338 |
| offset | 2.371 |
| receiver power calibration..... | 2.359 |
| system error | 2.299 |
| unidirectional two-port (ZVR) | 2.328 |
| unidirectional two-port (ZVRL) | 2.331 |
| Calibration kit..... | 2.343 |
| Calibration mode..... | 2.300 |
| Calibration procedure..... | 2.300 |
| TNA..... | 2.311 |
| TOM..... | 2.305 |
| TOM-X..... | 2.314 |
| TOSM..... | 2.312 |
| TOSM (ZVRE)..... | 2.318 |
| TRL | 2.309 |
| TRM | 2.307 |
| Calibration standard..... | 2.301 |
| Calibration test menu..... | 2.301 |
| CENTER (key)..... | 2.189, 3.103, 3.118 |
| CENTER = MARKER | 2.229, 2.243, 3.36 |
| Center value | 2.189 |
| CENTER X | 2.236, 2.275, 3.26 |
| CENTER Y | 2.236, 2.275, 3.26 |
| CH1 - CH4 (keys) | 2.245 |
| CH1...CH4 (keys) | 3.63 |
| Channel | |
| display..... | 2.245 |
| dual overlay | 2.61 |
| dual split..... | 2.61 |
| information..... | 2.50 |
| quad dual split | 2.62 |
| quad overlay..... | 2.62 |
| quad split..... | 2.63 |
| representation | 2.60 |
| single..... | 2.60 |
| CHARTER..... | 2.284, 3.46 |
| Charter diagram..... | 2.72 |
| CHIRP transformation..... | 2.107 |
| CHK VALUE SETTINGS (compression point)..... | 2.129 |
| CHK VALUE SETTINGS (intercept point)..... | 2.135 |
| CLEAR ALL MESSAGES | 2.154 |
| CLEAR MEM #..... | 2.295 |
| CLEAR MESSAGE..... | 2.154 |
| CLR (key) | 2.81 |
| COLOR ON/OFF | 2.161, 3.56 |
| Colors..... | 2.287 |
| COLORS..... | 2.287 |
| COLORS (selection table)..... | 2.289 |
| COM PORT 1..... | 2.144, 3.136, 3.137 |
| COM PORT 2..... | 2.144, 3.136, 3.137 |
| COM PORTS (selection table) | 2.144 |
| COM1/2 interface | 2.144 |
| Combined normalization..... | 2.336 |
| Combined normalization (ZVRL)..... | 2.340 |
| Commands | |
| common..... | 3.17 |
| COMMENT CHANNEL 1, ..., 4..... | 2.161, 3.59 |
| Common commands | 3.17 |
| COMP POINT INP/OUTP (compression point) | 2.129, 3.107 |
| COMPLEX | 2.266, 3.22 |
| COMPLEX CONVERTS..... | 2.176, 2.261, 3.40, 3.54 |
| COMPLEX MAGN/PHASE..... | 2.232, 3.25 |
| COMPRESS POINT..... | 2.127, 3.107 |
| COMPRESS SOI TOI | 2.126, 3.106, 3.107, 3.117, 3.118, 3.122 |
| Compression point | 2.126 |
| measurement..... | 2.127 |
| CONFIG (key) | 2.167 |
| CONFIG DISPLAY | 2.287 |
| Configuration | |
| save..... | 2.165 |
| Connector family | 2.300 |
| CONNECTOR TYPE..... | 2.346 |
| CONTINUOUS SWEEP | 2.205, 3.61 |
| CONV GAIN b1/a1 | 3.107 |
| CONV GAIN b2/a1 | 3.107 |
| CONV GAIN b1/Pa1..... | 2.256 |
| CONV GAIN b2/Pa1..... | 2.256 |
| Conversion | |
| display | 2.50 |
| Conversion gain | 2.256 |
| Copy | |
| file..... | 2.168 |
| COPY..... | 2.168, 3.65 |
| COPY LINE..... | 2.235 |
| COPY MEM TRACE | 2.158 |
| COPY SCREEN..... | 2.158, 3.58 |
| COPY TABLE | 2.158, 3.58 |
| COPY TRACE..... | 2.158, 3.59 |
| Correction | |
| entry..... | 2.90 |
| Coupled channels | 2.204 |
| COUPLED CHANNELS | 2.204, 3.63 |
| COUPLED MARKERS | 2.218, 3.30 |
| CREATE INST FILE..... | 2.351 |
| Crosstalk errors..... | 2.314 |
| Cursor (key) | 2.82 |
| Cursor key | |
| functions | 2.82 |
| CUTOFF FREQUENCY | 2.353 |
| D | |
| DATA ENTRY FIELD | 2.289 |
| DATA ENTRY OPAQUE | 2.290 |
| Data entry windows | |
| mouse control | 2.95 |
| Data set | |
| creation | 2.177 |
| partial..... | 2.172 |
| recall | 2.177 |
| save | 2.169 |
| DATA SET CLEAR..... | 2.171, 3.68 |
| DATA SET CLEAR (RECALL)..... | 2.179 |
| DATA SET CLEAR ALL | 3.69 |
| DATA SET CLEAR ALL (RECALL) | 2.179 |
| DATA SET LIST..... | 2.170 |

DATA SET LIST (RECALL) 2.179
 DATA SET LIST/CONTENTS (RECALL) (selection table)
 2.179
 DATA SET LIST/CONTENTS (SAVE) (selection table)
 2.170
 DATA TO MEMORY 2.292, 3.141
 Date
 input 2.147
 DATE 2.147, 3.137
 DB CARTESIAN 2.278, 3.46
 dB MAG AND PHASE 2.174, 2.221, 3.31, 3.53
 dB MAGNITUDE 2.220, 3.31
 DB POLAR 2.282, 3.46
 DC MEAS INPUT 1 2.264
 DC MEAS INPUT 2 2.264
 DEC SEP 2.175, 3.53
 Decimal separator 2.175
 DEF ARBITRARY (mixer measurements)
 2.123, 3.104, 3.121
 DEF CART SEGMENTS 2.279
 DEF COMP PNT MEAS
 2.128, 3.106, 3.107, 3.117, 3.118, 3.122
 DEF MIXER MEAS 2.119, 3.105
 DEF POLAR SEGMENTS 2.283
 DEF SOI MEAS 2.133, 3.106, 3.107, 3.122
 DEF SRC 1 PCAL SWEEP 2.369
 DEF SRC 2 PCAL SWEEP 2.369
 DEF SWEEP SEGMENTS 2.194, 3.110
 DEF TIME GATE 2.100
 DEF TOI MEAS 2.133, 3.106, 3.107, 3.122
 DEF TRANSF TYPE 2.106
 DEF TRIGGER 2.200, 3.144
 DEF X-AXIS 2.113, 3.42
 DEFAULT CONFIG (RECALL) 2.181, 3.71
 DEFAULT CONFIG (SAVE) 2.172, 3.71
 DEFAULT POSITION 2.290
 Default setup 2.183
 DEFAULT STEP SIZE 2.95
 DEFAULT VAL AND CHK SETTINGS OF SECOND /
 THIRD ORDER INTERCEPT POINT MEASUREMENT
 (table) 2.135
 DEFAULT VALUES AND CHECK SETTINGS OF
 COMPRESSION POINT MEASUREMENT (table) 2.129
 DEFINE B'DFILTER 2.225, 3.33
 DEFINE CIRCLE 2.236
 DEFINE MACRO 2.187
 DEFINE MATH 2.296, 3.38
 DEFINE PAUSE 2.188
 DEFINE RATIO 2.255, 3.107
 DEFINE RATIO (selection table) 2.255
 DEFINE SECTIONS 2.238
 DEFINE S-PARAMETERS (selection table) 2.250
 DEL ACTIVE POINT 2.367
 DEL ACTIVE POINT (EDIT POWER LOSS LIST) 2.371
 DEL ACTIVE SECTION 2.240
 DEL ACTIVE SEGMENT 2.197, 2.281, 3.111
 DEL ALL POINTS 2.367
 DEL ALL POINTS (EDIT POWER LOSS LIST) 2.370
 DEL ALL SECTIONS 2.240
 DEL ALL SEGMENTS 2.197, 2.281, 3.111
 Delay time 2.202
 DELAY TIME (OFFSET) 2.372, 3.96
 Delete
 file 2.168
 DELETE 2.168, 3.66, 3.68
 DELETE MACRO 2.188
 DELTA (key) 2.227
 Delta marker 2.58
 Delta markers 2.227
 DELTA OFF 2.228, 3.35
 DEVICE SETTINGS (selection table) 2.162

Diagram
 Cartesian 2.64, 2.278
 Charter 2.72, 2.284
 expand 2.286
 inverted Smith 2.284
 logarithmic 2.278
 polar diagram 2.68
 segmented 2.279
 Smith 2.71, 2.284
 smoothing 2.294
 DIAGRAM (key) 2.277
 Directory
 create 2.168
 rename 2.168
 Disable
 operation 2.93
 DISABLE ALL ITEMS (RECALL) 2.181, 3.71
 DISABLE ALL ITEMS (SAVE) 2.172, 3.71
 Diskette
 format 2.168
 Display 2.247
 brightness 2.287
 colors 2.287
 conversion 2.50
 formatting 2.52
 information on the diagram 2.50
 marker info list 2.74
 reference 2.53
 saturation 2.287
 scale reference 2.77
 scaling 2.52, 2.53
 sweep position 2.57
 sweep range 2.57
 DISPLAY (key) 2.285
 Display channels 2.245
 coupling 2.204
 Display line 2.56, 2.231
 DISPLAY OBJECTS (selection table) 2.287
 Display windows 2.73
 DISPLAYED DATA 2.176, 3.54
 Displays
 mouse control 2.96
 DIVIDED X AXIS 2.198, 3.46
 Documentation see *hardcopy*
 DOMAIN TIME FREQ 2.99, 3.20
 DOMAIN TIME FREQUENCY 3.40
 DRIVE PORT PORT1/PORT2
 2.254, 2.257, 2.258, 2.259, 2.260, 3.72
 DUAL CHAN OVERLAY 2.285, 3.45
 DUAL CHAN SPLIT 2.286, 3.45

E

EDIT CAL KIT PATH (menu table) 2.352
 EDIT COMMENT 2.171, 3.71
 EDIT DIELECTRIC 2.271
 EDIT DIELECTRIC (OFFSET) 3.97
 EDIT DIELECTRIC (selection table) 2.271
 EDIT NAME 2.235
 EDIT NAME (RECALL) 2.178, 3.67
 EDIT NAME (SAVE) 2.170, 3.68
 EDIT PATH 2.167
 EDIT PATH (RECALL) 2.178, 3.67
 EDIT PATH (SAVE) 2.170, 3.65
 EDIT POWER LOSS LIST 2.370, 3.120
 EDIT RTC TRIG TIME 2.203, 3.144
 EDIT SWEEP TIME 2.203, 3.112
 EDIT TIMER PERIOD 2.202, 3.144
 EDIT TITLE 2.291
 Editing
 parameter 2.88, 2.90
 ELECTRICAL LENGTH 2.269

ELECTRICAL LENGTH (OFFSET)..... 2.372, 3.97
 Electrostatic discharge..... 1.20
 Enable
 Front panel keys..... 2.182
 ENABLE ALL ITEMS (RECALL)..... 2.181, 3.71
 ENABLE ALL ITEMS (SAVE)..... 2.172, 3.71
 ENABLE NEW OPTION..... 2.149
 Enhancement label..... 2.53
 ARB..... 2.123
 AVG..... 2.212
 CA?..... 2.299
 CAI..... 2.299
 CAL..... 2.299
 CMP..... 2.127
 EXT..... 2.115
 FST..... 2.140
 H=2..... 2.118
 H=3..... 2.118
 HLD..... 2.205
 list of all..... 2.53
 MAT..... 2.293
 MIX..... 2.119
 PC..... 2.360
 PC(x)..... 2.360
 PC?..... 2.360
 PCi..... 2.360
 PCo..... 2.360
 SMO..... 2.294
 SOI..... 2.132
 TIM..... 2.99
 TOI..... 2.132
 TRF RTC..... 2.202
 TRG EXT..... 2.201
 TRG LIN..... 2.201
 TRG MAN..... 2.202
 TRG TIM..... 2.201
 ENTER (key)..... 2.81
 ENTER PASSWORD..... 2.150
 ENTER TEXT..... 2.160, 3.58
 Entry
 abort..... 2.81
 activate..... 2.84, 2.87
 correction..... 2.90
 terminate..... 2.81
 ENTRY LINE1/LINE2..... 2.232
 Error messages, list..... see Annex B
 Ethernet Adapter..... 1.43
 EXP (key)..... 2.81
 EXPAND..... 2.286, 3.46
 EXR SRC CONFIG..... 3.133, 3.134
 EXT LEVEL CONTROL..... 2.148
 EXT REF FREQUENCY..... 2.148, 3.109
 EXT SOURCES CONFIG (selection table)..... 2.120
 EXT SRC 1 POWER..... 2.210, 3.116
 EXT SRC 1 SLOPE..... 2.210, 3.116
 EXT SRC 2 POWER..... 2.211, 3.116
 EXT SRC 2 POWER CAL..... 2.369
 EXT SRC 2 SLOPE..... 2.211, 3.116
 EXT SRC CONFIG..... 3.132
 EXT SRC CONFIG..... 2.125, 2.369
 EXT SRC CONFIG (mixer measurement)..... 2.120
 EXT SRC1 (compression point)..... 2.131, 3.122
 EXT SRC1 EXT SRC2 (SOI)..... 2.137, 3.122
 EXT SRC1 EXT SRC2 (TOI)..... 2.137, 3.122
 EXT SRC2 (compression point)..... 2.131, 3.122
 Ext Trigger
 input..... A.23
 EXTERNAL..... 2.115, 3.62
 EXTERNAL (Trigger)..... 2.201, 3.144
 External generator..... 2.120

F

Fast Fourier transformation..... 2.107
 Fast Mode..... 2.140
 FAST MODE..... 2.140, 3.101
 FFT CHIRP..... 2.107, 3.41
 File
 copy..... 2.168
 delete..... 2.168
 rename..... 2.168
 sort..... 2.168
 FILE MANAGEMENT (selection table)..... 2.167
 Filter measurement
 measurement example..... 2.17
 Filtering
 frequency range..... 2.106
 Firmware Options
 enable..... 2.149
 FIRMWARE OPTIONS..... 2.153
 FIRMWARE OPTIONS (selection table)..... 2.149
 FIRMWARE VERSIONS..... 2.151
 FIRMWARE VERSIONS (selection table)..... 2.151
 FIXED IF (mixer measurements)..... 2.121, 3.105
 FIXED LO (mixer measurements)..... 2.121, 3.105
 FIXED POS STIMULUS..... 2.228
 FIXED POS X VAL..... 2.228, 3.35
 FIXED POS Y VAL..... 2.228, 3.35
 FIXED RF (mixer measurements)..... 2.121, 3.105
 Format
 ASCII..... 2.173
 FORMAT..... 2.176, 3.54
 FORMAT (key)..... 2.265
 FORMAT DISK..... 2.168, 3.66
 Formatting..... 2.265
 complex..... 2.266
 display..... 2.52
 imaginary part..... 2.267
 magnitude..... 2.266
 phase..... 2.266
 real part..... 2.266
 FORWARD..... 2.329, 3.93
 Fourier transformation, fast..... 2.107
 FREE RUN..... 2.201
 FREQ OFFS OF 2ND SRC (SOI)..... 2.134, 3.122
 FREQ OFFS OF 2ND SRC (TOI)..... 2.134, 3.122
 Frequency
 base..... 2.117
 equation..... 2.124
 fixed..... 2.121
 sweep..... 2.138
 FREQUENCY..... 2.210, 2.290, 3.121
 FREQUENCY APERTURE..... 2.268, 3.23
 FREQUENCY CONVERS..... 2.117, 3.104
 FREQUENCY SWEEP..... 2.138, 3.107
 Front panel
 keyboard emulation..... 2.2
 FTP
 operation..... 1.54
 FULL..... 2.214
 FULL ONE PORT..... 2.324, 3.93
 FULL PAGE..... 2.159, 3.60
 FULL TWO PORT..... 2.305
 FULL TWO PORT (ZVRE)..... 2.317
 Fuse..... 1.21
 G
 G/n (key)..... 2.81
 Gain factor..... 2.2
 Gate (time domain)..... 2.99
 GATE CENTER..... 2.105, 2.114, 3.21, 3.42
 GATE SPAN..... 2.105, 2.114, 3.21, 3.42

- GATE START 2.105, 2.114, 3.20, 3.41
 GATE STOP 2.105, 2.114, 3.20, 3.42
 Generator power calibration 2.355
 GOTO POINT # (EDIT POWER LOSS LIST) 2.371
 GOTO POINT # (SENSOR CAL FACTOR) 2.367
 GOTO SECTION # 2.240
 GOTO SEGMENT # 2.281
 GPIB ADDRESS 2.142, 3.131
 Graphic elements 2.287
 Grid 2.282
 harmonic 2.108
 linear 2.193
 logarithmic 2.193
 user-defined 2.193
 GRID 2.282
 GRID ANNOTATION 2.282
 Grid points
 for time-domain transformation 2.108
 Group delay 2.267
 GROUP DELAY 2.221, 2.267, 3.22, 3.31
- ## H
- Handshake protocol
 hardware 2.145
 software 2.146
 Hardcopy
 comments 2.160
 copy 2.155
 format 2.163
 output device 2.162
 position 2.159
 screen 2.158
 HARDCOPY DEVICE 2.162, 3.68
 Hardware 3.147
 HARDWARE+OPTIONS 2.152
 Harmonic Grid 2.108
 Header line 2.49
 HOLD (key) 2.93
- ## I
- IEC/IEEE bus
 address 2.142
 commands and related softkeys 3.160
 device messages 3.7
 interface A.1
 interface messages 3.6
 interfaces 3.1
 set address 3.2
 IF = BASE FREQ (mixer measurements) 2.120, 3.105
 IF BANDWIDTH 2.214, 3.77
 IF-Filter 2.212
 IMAGINARY 2.221, 2.267, 3.22, 3.31
 IMMEDIATE 3.144
 Impedance
 serial 2.261
 terminating 2.261
 IMPULSE STEP 2.108, 3.41
 INFO (Key) 2.151
 Information
 channel 2.50
 test parameter 2.50
 Information line 2.50
 Input
 a1 EXT IN A.24
 BLANK A.24
 Ext Trigger A.23
 LEVEL A.23
 PORT BIAS 1 / 2 A.23
 REF IN A.23
 INPUT 2.252, 3.107
 Input reflection coefficient 2.248
 INS NEW POINT 2.367, 3.135
 INS NEW POINT (EDIT POWER LOSS LIST) 2.371
 INS NEW SECTION 2.240, 3.25
 INS NEW SEGMENT 2.197, 2.281, 3.111
 Insertion loss 2.2
 INSTALL NEW KIT 2.352
 INSTALLED CAL KITS (menu table) 2.351
 INSTALLED COMPONENTS (selection table) 2.152
 INSTALLED OPTIONS (selection table) 2.152
 Instrument model 3.146
 INT SRC (compression point) 2.131
 INT SRC EXT SRC1 (SOI) 2.137, 3.122
 INT SRC EXT SRC1 (TOI) 2.137, 3.122
 INT SRC EXT SRC2 (SOI) 2.137, 3.122
 INT SRC EXT SRC2 (TOI) 2.137, 3.122
 INT SRC1 (compression point) 3.122
 INTC POINT INP/OUTP (SOI) 2.134, 3.107
 INTC POINT INP/OUTP (TOI) 2.134, 3.107
 Intercept 2.126
 measurement ($2^{nd}/3^{rd}$ order) 2.132
 Interface see Annex A
 printer A.22
 Interface configuration 2.141
 Interfaces
 IEC/IEEE bus 3.1
 RS-232-C 3.1
 Interpolation 2.342
 INVERTED SMITH 2.284, 3.46
 ISOLATION YES/NO (TOSM) 2.313
 ISOLATION YES/NO (TOSM, ZVRE) 2.319
 ITEMS TO RECALL (selection table) 2.181
 ITEMS TO SAVE (selection table) 2.172
- ## K
- k/m (key) 2.81
 KEEP FREQ STEP WIDTH 2.110, 3.41
 KEEP STOP FREQ 2.110, 3.41
 Key
 COPY (hardcopy) 2.155
 Key group
 CHANNEL 2.245
 LINES 2.231
 Keyboard
 connector A.24
 Keyboard, external
 connection 1.25
 K-FACTOR 3.107
- ## L
- L 2.221, 2.268, 3.22
 LED message
 REMOTE 3.2
 Length
 electrical 2.269
 Length offset 2.372
 Level error 2.298
 Limit check 2.244
 LIMIT CHECK 2.244, 3.24
 Limit line 2.56, 2.233
 cartesian diagram 2.238
 circle diagram 2.236
 copy 2.235
 move 2.242
 select 2.234
 LIMITS (key) 2.233
 LIN CARTESIAN 2.278, 3.46
 LIN MAG AND PHASE 2.174, 2.221, 3.31, 3.53
 LIN MAGNITUDE 2.220, 3.31
 LIN POLAR 2.282, 3.46

- LIN SWEEP 2.193, 3.104, 3.113
 Lin/Log
 display 2.51
 LINE 2.201, 3.144
 LINE 1 2.310, 3.92
 LINE 2 2.310, 3.92
 LINE SECTIONS (selection table) 2.239
 Line style
 selection of 2.164
 LINE STYLE CHn 2.164
 LINE STYLE MEM TRACE 2.164
 LINES (key) 2.231
 LIST INSTD KITS 2.351
 LO = BASE FREQ (mixer measurements) 2.120, 3.105
 LO EXT SRC1/SRC2 (mixer measurements) 2.120, 3.105
 LOAD STATE 3.67
 LOCAL (key) 2.182
 LOCK ALL 2.93
 LOCK DATA 2.93
 LOG CARTESIAN 2.278, 3.46
 LOG POLAR 2.282, 3.46
 LOG SWEEP 2.193, 3.104, 3.113
 Login 1.23
 Login (NT controller) 1.23
 Logo 2.53, 2.290
 LOGO 2.290
 Logout 1.23
 LOW FIRST SIDELobe 2.111, 3.42
 LOWER LEFT 2.160, 3.60
 LOWER RIGHT 2.160, 3.60
 LOWPASS DC S-PARAM 2.110
 LPT
 interface A.22
- M**
- M/μ (key) 2.81
 Macro
 abort 2.182
 definition 2.187
 start 2.185
 MACRO 1...7 2.186
 MACRO TITLE 2.188
 MAGNITUDE 2.266, 3.22
 MAGNITUDE (OFFSET) 2.372, 3.98
 Maintenance 4.1
 MAKE DIRECTORY 2.168, 3.67
 MANUAL (trigger) 2.202
 Manual control
 switchover 2.182
 MANUAL STEP SIZE 2.94
 MANUAL TRIGGER 2.202, 3.144
 Marker 2.58
 active 2.215
 display of active value 2.53
 formatting 2.219
 Lists 2.73
 marker position 2.215
 marker value 2.215
 reference 2.227
 representation 2.73
 symbols 2.73
 MARKER (key group) 2.215
 MARKER 1 2.217, 3.30, 3.31
 MARKER CONT/DISCR 2.222, 3.30
 MARKER CONVERS 2.218
 MARKER DATA/MEM 2.218, 3.31
 MARKER INFO 2.222
 Marker info list 2.74, 2.222
 MATCH BOTH PORTS (TOM-X) 2.315, 3.92
 MATCH BOTH PORTS (TOSM) 2.314, 3.92
 MATCH BOTH PORTS (TOSM, ZVRE) 2.319, 3.92
 MATCH P1 OPEN P2 3.92
 MATCH PORT 1 2.306, 2.308, 2.310, 3.92
 MATCH PORT 1 (FULL ONE PORT) 2.325, 3.92
 MATCH PORT 1 (FULL ONE PORT, ZVRL) 2.328, 3.92
 MATCH PORT 1 (ONE PATH, ZVR) 2.330, 3.92
 MATCH PORT 1 (ONE PATH, ZVRL) 2.332, 3.92
 MATCH PORT 1 (TOSM) 2.313, 3.92
 MATCH PORT 1 (TOSM, ZVRE) 2.319, 3.92
 MATCH PORT 2 2.306, 2.308, 2.310, 3.92
 MATCH PORT 2 (FULL ONE PORT) 2.326, 3.92
 MATCH PORT 2 (ONE PATH, ZVR) 2.330, 3.92
 MATCH PORT 2 (TOSM) 2.313, 3.92
 MATCH PORT 2 (TOSM, ZVRE) 2.319, 3.92
 MATH 2.176, 3.54
 MATH DATA/MEM 2.294
 MATH DATA+MEM 2.295
 MATH DATA-MEM 2.294, 2.295
 MATH DATAxMEM 2.295
 MATH MEM/DATA 2.295
 MATH USER DEF'D 2.295
 MAX = MARKER 2.230
 MAX MODE 2.224, 3.33
 MAX VALUE 2.274, 3.49
 MAXIMUM FLATNESS 2.102, 3.21
 MEAS (key) 2.247
 MEAS FREQ SUM/DIFF (SOI) 2.134, 3.107
 MEAS SIDEB LSB USB (TOI) 2.134, 3.107
 Measured diagram
 scaling 2.272
 Measured quantity
 conversion 2.261
 diagram 2.277
 formatting 2.265
 manipulating mathematically 2.292
 storing 2.292
 Measurement
 direct input signal 2.252
 ratio 2.255
 save 2.165
 Measurement example
 filter measurement 2.17
 transmission measurement 2.2
 Measuring diagram 2.58
 Measuring Instruments
 ZVC, ZVCE 5.52
 ZVR, ZVRE, ZVRL 5.1
 MECHANICAL LENGTH 2.270
 MECHANICAL LENGTH (OFFSET) 3.96
 MECHANICAL LENGTH (OFFSET) 2.373
 MEM 1, ..., MEM 8 2.294
 Memory
 battery-powered 1.22
 configuration 2.167
 Menu
 arrows 2.79
 call 2.79
 change keys 2.80
 Message windows 2.73
 Messages
 acknowledgement 2.76
 MICROSOFT NET
 operation 1.48
 MIDDLE = MARKER 2.242
 MIDDLE VAL/DELTA LIM 2.241
 MIN = MARKER 2.230
 MIN MODE 2.224, 3.33
 MIN VALUE 2.274, 3.49
 MIXER MEAS 2.119, 3.104
 Mode
 Delta marker 2.228
 external measurement 2.115
 fast mode 2.140

frequency sweep 2.138
 frequency-converting measurements 2.117
 mixer measurements 2.119
 power sweep 2.139
 reference mixer 2.140
 segmented sweep 2.194
 single point measurement 2.192
 time sweep 2.139
 MODE (key) 2.97
 MODEL TYPE (selection table) 2.151, 2.152
 MODIFY CAL KIT 2.343
 MODIFY STANDARDS 2.348, 3.95
 MODIFY XX YY STANDARDS (selection table) 2.348
 Module
 information on 2.152
 Monitor
 connection 1.26
 Mouse
 connection 1.25
 connector A.25
 operation 2.95
 Mouse control
 display elements 1.1
 MOVE LINE 2.232, 2.242
N
 N 50 Ω 2.346, 3.93
 N 50 Ω FEMALE 2.301, 2.302, 3.93
 N 50 Ω MALE 2.302, 3.93
 N 75 Ω 2.346, 3.93
 N 75 Ω FEMALE 2.302, 3.93
 N 75 Ω MALE 2.302, 3.93
 network operating system
 FTP 1.54
 MICROSOFT NET 1.48
 NOVELL NETWARE 1.48
 TCP/IP 1.53
 NO PROFILING 2.110, 3.42
 NORMAL (key) 2.215
 NORMAL GATE 2.102, 3.21
 NORMAL PROFILE 2.111, 3.42
 NOVELL NETWARE
 operation 1.48
 NT controller 1.23
 NUMBER OF POINTS 2.199, 3.113
 NUMBER OF READINGS 2.368, 3.120
 NUMBER OF SWEEPS 2.205, 3.112
 NUMBER OF TABLE ROWS 2.198
O
 OFFSET (key) 2.371
 Offset quantities 2.371
 ONE PATH TWO PORT 3.93
 Open 2.303
 OPEN BOTH PORTS 2.315, 3.92
 OPEN P1 MATCH P2 2.315, 3.92
 OPEN PORT 1 2.306, 3.92
 OPEN PORT 1 (FULL ONE PORT) 2.325, 3.92
 OPEN PORT 1 (FULL ONE PORT, ZVRL) 2.327, 3.92
 OPEN PORT 1 (ONE PATH, ZVR) 2.330, 3.92
 OPEN PORT 1 (ONE PATH, ZVRL) 2.331, 3.92
 OPEN PORT 1 (REFL NORM, ZVR) 2.335, 3.92
 OPEN PORT 1 (REFL NORM, ZVRL) 2.339, 3.92
 OPEN PORT 1 (TOSM) 2.313, 3.92
 OPEN PORT 1 (TOSM, ZVRE) 2.318, 3.92
 OPEN PORT 1 (TRANS AND REFL NORM, ZVR) 2.337, 3.92
 OPEN PORT 1 (TRANS AND REFL NORM, ZVRL) 2.340, 3.92
 OPEN PORT 2 2.306, 3.92

OPEN PORT 2 (FULL ONE PORT) 2.325, 3.92
 OPEN PORT 2 (ONE PATH, ZVR) 2.330, 3.92
 OPEN PORT 2 (REFL NORM, ZVR) 2.335, 3.92
 OPEN PORT 2 (TOSM) 2.313, 3.92
 OPEN PORT 2 (TOSM, ZVRE) 2.318, 3.92
 OPEN PORT 2 (TRANS AND REFL NORM, ZVR) 2.337, 3.92
 OPERAND X (selection table) 2.296
 Operating mode
 time domain 2.99
 Operational site 1.20
 OPERATOR X (selection table) 2.297
 Option
 external measurements, ZVR-B25 2.115
 frequency-converting measurements, ZVR-B4 2.117
 FSE-B16 - Ethernet Adapter 1.43
 nonlinear measurements, ZVR-B5 2.126
 reference mixer 2.140
 reference mixer, ZVR-B6 2.140
 Time Domain Transformation, ZVR-B2 2.98
 OPTIONS 2.149
 Output
 a1 EXT OUT A.24
 REF OUT A.23
 TRIGGER A.24
 Output reflection coefficient 2.249
 Output unit 3.148

P

PAE 2.264
 PAGE DOWN (DATA SET LIST) 2.171
 PAGE DOWN (FILE MANAGEMENT) 2.168
 PAGE DOWN (RECALL) 2.179
 PAGE UP (DATA SET LIST) 2.171
 PAGE UP (FILE MANAGEMENT) 2.168
 PAGE UP (RECALL) 2.179
 Parameter
 editing 2.88, 2.90
 selection 2.83
 Parameters 2.204
 coupled 2.204
 Parasitic capacitance 2.350
 Parasitic inductance 2.350
 Password
 Windows NT 1.23
 Path 2.167
 PC 3.5 2.346, 3.93
 PC 3.5 FEMALE 2.302, 3.93
 PC 3.5 MALE 2.302, 3.93
 PC 7 2.346, 3.93
 PC Monitor
 Connector A.25
 PEAK TO PEAK 2.228, 3.36
 Performance Test Report
 (ZVR, ZVRE, ZVRL) 5.17
 ZVC, ZVCE 5.66
 PERIODIC TIMER 2.201, 3.144
 PHASE 2.220, 2.266, 3.22, 3.31
 PHASE (OFFSET) 2.372, 3.98
 Phase delay 2.269
 PHASE DELAY 2.269
 Phase offset 2.372
 PHASE UNWRAP 2.269, 3.22
 Plotter
 connection 1.28
 POINTS/DEC 2.200, 3.113
 Polar diagram 2.68
 PORT 1 2.324, 3.93
 PORT 1 (REFL NORM, ZVR) 2.335
 PORT 1 CONNECTOR 2.301, 3.93
 PORT 2 2.324, 3.93

- PORT 2 (REFL NORM, ZVR) 2.335
 PORT1/PORT2..... 2.372
 POWER..... 2.208, 3.115
 Power added efficiency..... 2.264
 Power loss list 2.369
 POWER LOSS LIST (selection table)..... 2.370
 POWER MTR CONFIG 2.365, 3.132, 3.135
 POWER MTR CONFIG (selection table)..... 2.365
 POWER MTR TYPE (selection table)..... 2.365
 POWER SWEEP..... 2.139, 3.107
 3.99
 Preset..... 2.183
 PRESET (key)..... 3.139
 Printer
 connection..... 1.28, A.22
 Probe Power
 connector A.23
 Processing of measured values..... 2.22
- Q**
- QUAD CHAN DUAL SPLIT..... 2.286, 3.45
 QUAD CHAN OVERLAY 2.286, 3.45
 QUAD CHAN QUAD SPLIT..... 2.286, 3.45
 Quality factor 2.226
 QUALITY FACTOR..... 2.226, 3.34
- R**
- Rack
 installation 1.21
 RADIUS..... 2.237, 2.276, 3.27
 Rated specifications
 generator (ZVC, ZVCE)..... 5.53
 generator (ZVR)..... 5.2
 measuring instruments 5.1, 5.52
 receiver (ZVC, ZVCE)..... 5.58
 test sequence (ZVC, ZVCE) 5.53
 test sequence (ZVR, ZVRE, ZVRL) 5.2
 test set (ZVC, ZVCE)..... 5.63
 test set (ZVR, ZVRE, ZVRL)..... 5.14
 testing 5.1
 5.9
 5.65
 5.17
 RATIO 2.255, 2.258, 3.107
 REAL 2.220, 2.266, 3.22, 3.31
 REAL AND IMAGINARY..... 2.174, 2.221, 3.31
 REAL TIME CLOCK 2.202, 3.144
 Real-time clock..... 2.202
 Recall
 data set 2.177
 RECALL (key)..... 2.177
 RECALL DATA SET (selection table) 2.178
 Receiver power calibration..... 2.356
 RECORD ON/OFF..... 2.187
 Reduction factor (wave velocity)..... 2.270
 REF VAL = MARKER 2.230, 3.37
 Reference
 external 2.148
 Reference admittance..... 2.261
 Reference circle..... 2.56
 REFERENCE EXT/INT..... 2.148, 3.109
 Reference line 2.56, 2.273
 REFERENCE MIXER..... 2.140
 REFERENCE POSITION 2.273, 3.48
 Reference value 2.273
 REFERENCE VALUE..... 2.273, 3.48
 REFL NORM (ZVR)..... 2.334, 3.93
 REFL NORM (ZVRL)..... 2.339, 3.93
 REFLECT PORT 1 2.308, 2.309, 3.93
 REFLECT PORT 2..... 2.308, 2.310, 3.93
 Reflection coefficient 2.248
 Reflection normalization (ZVR)..... 2.334
 Reflection normalization (ZVRL)..... 2.339
 Remote control..... 2.121, 3.1 see SCPI-standard
 ABORt 3.20
 CALCulate 3.20
 DIAGnostic..... 3.44
 DISPlay..... 3.45
 FORMat..... 3.52
 HCOPy 3.55
 indication..... 2.182
 INITiate 3.61
 INPut..... 3.62
 INSTrument 3.63
 instrument model 3.146
 MMEMory 3.64
 OUTPut..... 3.72
 SENSe..... 3.76
 set transmission parameters 3.3
 SOURce..... 3.114
 STATus..... 3.123
 switching on 3.2
 SYSTem 3.130
 TRACe..... 3.140
 TRIGger..... 3.144
 Remote Control
 PROGram..... 3.74
 Rename
 directory..... 2.168
 file..... 2.168
 RENAME..... 2.168, 3.67
 REPEAT PREV CAL 2.341
 Reset
 instrument..... 2.183
 RESET COLORS 2.289
 RESET OFFSETS..... 2.372
 RESPONSE (key group) 2.247
 RESTART (key) 2.206
 RESTORE INSTD KITS 2.351
 RESUME CAL..... 2.341
 REVERSE..... 2.329, 3.93
 RF = BASE FREQ (mixer measurements)..... 2.120, 3.105
 RJ45 (star topology)..... 1.44
 RLC ELEMENTS..... 2.221
 Rohde & Schwarz logo..... 2.53
 Rollkey
 functions 2.82
 RS-232-C
 interface..... A.5
- S**
- S 2.219, 2.261, 3.31, 3.40
 S11 REFL PORT1..... 2.248, 3.107
 S12 TRANS REV..... 2.249, 3.107
 S21 TRANS FWD 2.248, 3.107
 S22 REFL PORT2..... 2.249, 3.107
 SATURATION..... 2.288
 Save
 configuration 2.165
 data set..... 2.169
 measurement..... 2.165
 SAVE (key) 2.169
 SAVE DATA SET (selection table)..... 2.169
 SCALE (key) 2.272
 Scale Reference Fields 2.77
 SCALE/DIV 2.273, 3.48
 Scaling..... 2.273
 abscissa..... 2.65
 automatic 2.273
 circular 2.71

- display 2.52, 2.53
- ordinate 2.66
- radial 2.69
- reference value 2.273
- SCPI-standard 3.1
 - block data 3.13
 - boolean parameters 3.12
 - command line 3.11
 - commands 3.8
 - device-independent commands 3.8
 - device-specific commands 3.9
 - introduction 3.8
 - key words 3.10
 - numerical values 3.12
 - parameters 3.12
 - queries 3.11
 - strings 3.13
 - syntax elements 3.13
 - text parameters 3.13
- SCPI-status register 3.149
 - IST flag 3.153
 - service request enable register 3.152
 - status byte 3.152
- SCR. MODE ON/OFF 3.46
- SCR. SAVER ON OFF 2.290
- SCR. SAVER ON/OFF 3.46
- SCR. SAVER TIME 2.290, 3.46
- Screen 2.48
 - diagram area 2.49
 - setup 2.48
 - softkey area 2.59
 - subdivision 2.60
- SEARCH 2.223, 2.225, 3.32
- SEARCH ← NEXT 2.224, 3.32
- SEARCH (key) 2.223
- SEARCH NEXT 2.224, 3.32
- SEARCH NEXT 2.224, 3.32
- SECOND HARMONIC 2.118, 3.104
- SEG SWEEP 2.193, 3.104
- Segment list (sweep) 2.193
- Segmentation 2.279
 - Cartesian 2.279
 - radial 2.283
- SEGMENTED CARTESIAN 2.278, 3.46
- SEGMENTED POLAR 2.282, 3.46
- SEL BAND (mixer measurements) 2.122, 3.106
- SEL ITEMS TO COPY 2.158
- SEL ITEMS TO RECALL 2.180, 3.69
- SEL ITEMS TO SAVE 2.172, 3.69
- SELECT KIT 3.93
- SELECT LINE 2.234
- SELECT MACRO 2.188
- SELECT OBJECT 2.288
- SELECT OBJECT (selection table) 2.288
- SELECT QUADRANT 2.159, 3.60
- SELECT UNIT 2.253
- SELECT UNIT (selection table) 2.253
- Selection table
 - position 2.289
- SELFTTEST (selection table) 2.153
- SENSOR A CAL FACTOR 2.367
- SENSOR A CAL FACTOR LIST (selection table) 2.367
- SENSOR B CAL FACTOR LIST (selection table) 2.367
- SENSOR LABEL 2.368
- Serial admittance 2.261
- Serial impedance 2.261
- Serial interface
 - configuration 2.144
- SERVICE 2.150
- Service request see SRQ
- SET COLOR 2.289
- SET DIELECTRIC 2.270
 - SET DIELECTRIC (OFFSET) 2.373, 3.97
 - SET DIELECTRIC (selection table) 2.270
 - SET FREQS LOWPASS 2.109
 - SET PATH 3.65
 - SET PATH A
 - \ (RECALL) 2.179
 - \ (SAVE) 2.170
 - \ (SETTING) 2.159
 - SET PATH C
 - \.. (RECALL) 2.179
 - \.. (SAVE) 2.170
 - ...\ (SETTING) 2.159
 - SET Z0 2.259, 2.262
 - SETTINGS DEVICE 1, 2 3.56, 3.68, 3.131
 - Settling time 2.129
 - SETTLING TIME (compression point) 2.129, 3.106
 - SETTLING TIME (SOI) 2.134, 3.106
 - SETTLING TIME (TOI) 2.134, 3.106
 - Setup 2.141
 - general 2.142
 - SETUP (key) 2.141
 - SEXLESS USR CONN 1 2.347, 3.93
 - SEXLESS USR CONN1 2.302
 - SHAPE FACT 60 dB / 3 dB 2.226, 3.34
 - SHAPE FACT 60 dB / 6 dB 2.226, 3.34
 - Shape factor 2.226
 - SHORT PORT 1 2.313, 3.92
 - SHORT PORT 1 (FULL ONE PORT) 2.325, 3.92
 - SHORT PORT 1 (FULL ONE PORT, ZVRL) 2.327, 3.92
 - SHORT PORT 1 (ONE PATH, ZVR) 2.330, 3.92
 - SHORT PORT 1 (ONE PATH, ZVRL) 2.332, 3.92
 - SHORT PORT 1 (TOSM, ZVRE) 2.319, 3.92
 - SHORT PORT 2 2.313, 3.92
 - SHORT PORT 2 (FULL ONE PORT) 2.325, 3.92
 - SHORT PORT 2 (ONE PATH, ZVR) 2.330, 3.92
 - SHORT PORT 2 (TOSM, ZVRE) 2.319, 3.92
 - SHOW DATA 2.293
 - SHOW LINE 2.232, 2.244
 - SHOW MATH 2.293, 3.38
 - SHOW MEM 2.293, 3.51
 - Sign (key) 2.81
 - SINGLE CHANNEL 2.285, 3.45
 - SINGLE POINT 2.192, 3.104
 - Single point measurement 2.192
 - SINGLE SWEEP 2.205, 3.61
 - SIZE X 2.275
 - SIZE Y 2.276
 - SLIDE 1 (FULL ONE PORT, ZVRL) 2.328
 - SLIDE PORT 1 2.307, 2.308, 2.313, 3.92
 - SLIDE PORT 1 (FULL ONE PORT) 2.326, 3.92
 - SLIDE PORT 1 (ONE PATH, ZVR) 2.330, 3.92
 - SLIDE PORT 1 (ONE PATH, ZVRL) 2.332, 3.92
 - SLIDE PORT 1 (TOSM, ZVRE) 2.319, 3.92
 - SLIDE PORT 2 2.307, 2.308, 2.313, 3.92
 - SLIDE PORT 2 (FULL ONE PORT) 2.326, 3.92
 - SLIDE PORT 2 (ONE PATH, ZVR) 2.330, 3.92
 - SLIDE PORT 2 (TOSM, ZVRE) 2.319, 3.92
 - Sliding load 2.303
 - SLOPE 2.208, 3.116
 - Slope factor 2.208
 - SLOPE POS/NEG 2.202, 3.145
 - SMA 2.346, 3.93
 - SMA FEMALE 2.302, 3.93
 - SMA MALE 2.302, 3.93
 - SMITH 2.284, 3.46
 - Smith chart
 - inverted 2.72
 - Smoothing 2.294
 - SMOOTHING 2.294, 3.39
 - SMOOTHING APERTURE 2.294, 3.39
 - SMOOTHING function 2.176

| | |
|--|---------------------------|
| Softkey | |
| ENABLE DEV1 / DEV2..... | 2.163 |
| GENERAL SETUP..... | 2.142 |
| MONITOR CONNECTED..... | 2.147 |
| SETTINGS DEVICE 1/2..... | 2.162 |
| Softkey | |
| display..... | 2.59 |
| EXT SRC CONFIG..... | 2.130 |
| IEC/IEEE bus..... | 2.59 |
| menu..... | 2.59 |
| related IEC/IEEE-bus commands..... | 3.160 |
| Softkey TRANS NORM (ZVRL)..... | 2.338 |
| SOI..... | 2.132, 3.107 |
| SORT MODE..... | 2.168 |
| SOURCE (key)..... | 2.207 |
| Span..... | 2.189 |
| SPAN (key)..... | 3.103, 3.119 |
| SPAN (key)..... | 2.189 |
| SPAN = MARKER..... | 2.230 |
| SRC POWER MAX LIMIT (compression point) | |
| | 2.128, 3.117, 3.118 |
| SRC POWER MAX LIMIT (SOI)..... | 2.133 |
| SRC POWER MAX LIMIT (TOI)..... | 2.133 |
| SRC POWER MIN LIMIT (compression point) | |
| | 2.128, 3.117, 3.118 |
| SRC POWER MIN LIMIT (SOI)..... | 2.133 |
| SRC POWER MIN LIMIT (TOI)..... | 2.133 |
| SRQ | |
| indication..... | 2.182 |
| Stability factor..... | 2.263 |
| Standby..... | 1.21 |
| Standing wave ratio..... | 2.267 |
| START (key)..... | 2.189, 3.57, 3.103, 3.119 |
| START = MARKER..... | 2.229, 3.36 |
| START AUTOKAL..... | 2.321 |
| START NEW CAL..... | 2.300 |
| START NEW POWER CAL..... | 3.116 |
| START POWER CAL..... | 2.355 |
| Start value..... | 2.189 |
| Start-Up..... | 1.20 |
| Status registers..... | 3.151 |
| Status reporting service request..... | 3.157 |
| Status reporting system..... | 3.147 |
| error queue query..... | 3.158 |
| parallel poll..... | 3.158 |
| queries..... | 3.158 |
| reset values..... | 3.159 |
| serial poll..... | 3.157 |
| use..... | 3.157 |
| STEEP EDGES..... | 2.101, 3.21 |
| STEEP FALLOFF..... | 2.111, 3.42 |
| STEEPEST EDGES..... | 2.100, 3.21 |
| STEP (key)..... | 2.94 |
| STEP APERTURE..... | 2.267, 3.23 |
| STEP ATT a1..... | 2.209, 3.72 |
| STEP ATT a1 AND a2..... | 2.209, 3.72 |
| STEP ATT a2..... | 2.210, 3.72 |
| STEP ATT b1..... | 2.210, 3.62 |
| STEP ATT b2..... | 2.210, 3.62 |
| STEP SIZE..... | 2.200, 3.113 |
| Stepsize | |
| settings..... | 2.94 |
| STIMULUS (key group)..... | 2.189 |
| STOP (key)..... | 2.189, 3.103, 3.119 |
| STOP = MARKER..... | 2.229, 3.36 |
| Stop value..... | 2.189 |
| SUPER COMPACT..... | 2.174 |
| SUPERCOMPACT..... | 3.53 |
| Sweep | |
| indikator..... | 2.57 |
| SWEEP (key group)..... | 2.191 |
| SWEEP (key)..... | 2.191 |
| SWEEP DIR FWD/REV..... | 2.205, 3.113 |
| Sweep direction..... | 2.205 |
| Sweep line..... | 2.57 |
| Sweep modes..... | 2.138 |
| Sweep segments..... | 2.194 |
| SWEEP SEGMENTS (selection table)..... | 2.195 |
| SWEEP START/HOLD..... | 2.205 |
| Sweep time..... | 2.203 |
| automatic setting..... | 2.203 |
| manual setting..... | 2.203 |
| SWEEP TIME AUTO/MAN..... | 2.203, 3.112 |
| SWEEP TYPE..... | 2.138, 3.107 |
| switch-on test..... | 4.2 |
| SWR..... | 2.221, 2.267, 3.22, 3.31 |
| SYMMETRIC NETWORK..... | 2.311 |
| SYSTEM (key group)..... | 2.97 |
| System error..... | 2.298 |
| System error calibration..... | 2.299 |
| System messages..... | 2.76, 2.153 |
| SYSTEM MESSAGES..... | 2.153 |
| System-error correction..... | 2.213 |
| T | |
| Table | |
| operation..... | 2.85 |
| scrolling..... | 2.87 |
| TAKE CAL SWEEP..... | 2.368, 3.120 |
| TARGET MODE..... | 2.224, 3.33, 3.34 |
| Target search mode..... | 2.224 |
| TCP/IP | |
| operation..... | 1.53 |
| Terminating admittance..... | 2.261 |
| Terminating impedance..... | 2.261 |
| Test parameter | |
| information..... | 2.50 |
| Test Sequence | |
| ZVC, ZVCE..... | 5.53 |
| ZVR, ZVRE, ZVRL..... | 5.2 |
| Testing the Rated Specifications..... | 5.1 |
| Thick Ethernet..... | 1.44 |
| Thin Ethernet..... | 1.43 |
| THIRD HARMONIC..... | 2.118, 3.104 |
| THROUGH (ONE PATH, ZVR)..... | 2.330, 3.92 |
| THROUGH (ONE PATH, ZVRL)..... | 2.332, 3.92 |
| THROUGH (TNA)..... | 2.311, 3.92 |
| THROUGH (TOM)..... | 2.306, 3.92 |
| THROUGH (TOM-X)..... | 2.314, 3.92 |
| THROUGH (TOSM)..... | 2.313, 3.92 |
| THROUGH (TOSM, ZVRE)..... | 2.318, 3.92 |
| THROUGH (TRANS AND REFL NORM, ZVR)..... | 2.337, 3.92 |
| THROUGH (TRANS AND REFL NORM, ZVRL)..... | 2.340, 3.92 |
| THROUGH (TRANS NORM, ZVR)..... | 2.333, 3.92 |
| THROUGH (TRANS NORM, ZVRL)..... | 2.338, 3.92 |
| THROUGH (TRL)..... | 2.309, 3.92 |
| THROUGH (TRM)..... | 2.308, 3.92 |
| Time | |
| input..... | 2.147 |
| TIME..... | 2.147, 3.139 |
| Time domain..... | 3.20 |
| TIME DOMAIN..... | 2.98, 2.176, 3.54 |
| TIME GATE..... | 2.99, 3.20 |
| Time sweep..... | 2.139 |
| TIME SWEEP..... | 2.139, 3.107 |
| TINT..... | 2.288 |
| TITLE..... | 2.291 |
| Title line..... | 2.49, 2.291 |
| TNA..... | 2.311, 3.93 |
| TOI..... | 2.132, 3.107 |
| Tolerance band..... | 2.239 |
| Tolerance circles..... | 2.236 |
| TOM..... | 2.305, 3.93 |

- TOM-X..... 2.314, 3.93
TOSM..... 2.312, 3.93
TOSM (ZVRE)..... 2.318, 3.93
TOUCHSTONE..... 2.173, 3.53
Trace..... 2.58
TRACE (key)..... 2.292
TRACE MATH function..... 2.176
Tracking..... 2.223
TRACKING..... 2.224, 3.32
TRANS AND REFL NORM (ZVR)..... 2.336, 3.93
TRANS AND REFL NORM (ZVRL)..... 2.340, 3.93
TRANS FWD REFL P1 (ZVR)..... 2.337, 3.93
TRANS FWD REFL P21..... 3.93
TRANS NORM (ZVR)..... 2.333, 3.93
TRANS REV REFL P2 (ZVR)..... 2.337
Transmission coefficient..... 2.248
Transmission measurement
 measurement example..... 2.2
Transmission normalization (ZVR)..... 2.333
Transmission normalization (ZVRL)..... 2.338
TRC COLOR AUTO INC..... 2.161, 3.59
TRIGGER DELAY..... 2.202, 3.145
Trigger mode..... 2.200
 external..... 2.201
 free-running measurement..... 2.201
 internal..... 2.201
 manual..... 2.202
TRIGGER SWEEP/POINT..... 2.202, 3.145
TRL..... 2.309, 3.93
TRM..... 2.307, 3.93
TWO PORT NORM..... 3.93
TWO PORT NORM (ZVR)..... 2.337
Two-tone signal..... 2.126
- U**
- UNCAL..... 3.98
UNINSTALL KITS..... 2.352
Unit (key)..... 2.81
UNLOCK..... 2.93
UPDATE MESSAGES..... 2.154
UPPER LEFT..... 2.160, 3.60
UPPER LIM/LOWER LIM..... 2.241, 3.26
UPPER RIGHT..... 2.160, 3.60
USE CURSOR..... 2.237, 2.240
USE LINE STYLE..... 2.164
USE MARKER..... 2.237, 2.241, 2.242
USE MIN STEP WIDTH..... 2.110, 3.41
USE POWER LOSS LIST..... 2.369, 3.121
USE SENSOR A/B..... 2.368, 3.134
User
 interface..... A.21
USER (key)..... 2.185
USER CONN IMPEDANCE..... 2.354
USER CONN NAME..... 2.354
USER DEF'D S-PARAMS..... 2.250
User port
 configuration..... 2.143
USER PORT A..... 2.143, 3.62, 3.73
USER PORT B..... 2.143, 3.62, 3.73
USERPORTS (selection table)..... 2.143
USR CONN 2..... 2.347, 3.93
USR CONN 2 FEMALE..... 2.302
USR CONN 2 MALE..... 2.302
- V**
- VIEW ACTIVE STD..... 2.350
- W**
- WAVEGUIDE..... 2.353
WIDTH..... 2.226, 3.33
- Windows NT..... 1.23
 administrator..... 1.23
 login..... 1.23
 password..... 1.23
- X**
- X DB COMP POINT (compression point)..... 2.129, 3.107
X GRID LIN/LOG..... 2.198, 3.113
X OFFSET..... 2.243
X POSITION..... 2.290
x1 (key)..... 2.81
X-AXIS DISTANCE..... 2.113, 3.42
X-AXIS DISTANCE/2..... 2.114, 3.42
X-AXIS TIME..... 2.113, 3.42
- Y**
- Y..... 2.219, 2.262, 3.31, 3.40
Y GRID DB..... 2.281
Y GRID LIN..... 2.281
Y GRID LOG..... 2.281
Y OFFSET..... 2.243
Y POSITION..... 2.290
Y SEGMENTS (selection table)..... 2.280
Y/Y0..... 2.219, 2.262, 3.31, 3.40
- Z**
- Z..... 2.219, 2.262, 3.31, 3.40
ZZ0..... 2.219, 2.262, 3.31, 3.40
ZERO DELAY AT MARKER..... 2.230
Zoom..... 2.275
ZOOM..... 2.275, 2.276
- Δ**
- Δ REF = FIXED POS..... 2.228, 3.35
Δ REF = MARKER 1..... 2.228, 3.35
- μ**
- μ1-FACTOR..... 3.107
μ2-FACTOR..... 3.107

Supplement A to Operating Manual ZVRL, ZVRE, ZVCE, ZVR, ZVC, ZVM and ZVK Vector Network Analyzer

**Note the following corrections
to the data sheet PD 757.1802.24 number 05/00
and to the data sheet PD 757.5543.22 number 11/00**

Data sheet PD 757.1802.24 (ZVRL, ZVRE, ZVCE, ZVR, ZVC) number 05/00

Crosstalk between measurement channels with total reflection at test ports **page 10**
(values for 75 Ω models and the ZVC/E models with SWR bridges are 6 dB higher)

ZVRE and ZVR: Accuracy of transmission measurements page 11

Footnote 1) < 0.2 dB or <1° for 300 kHz to 100 MHz (ZVRE)
..... < 0.2 dB or <1° for 300 kHz to 20 MHz (ZVR)

Linearity above 40 kHz (referred to -10 dBm) page 13

-15 dBm to -25 dBm (ZVR/E/L)..... < 0.6 dB
-15 dBm to -25 dBm (ZVC/E)..... < 0.8 dB

Harmonics page 13

At -10 dBm source power ZVCE,ZVC
above 600 MHz..... < -30 dBc

RMS noise level (50 W, without options) page 13

With 75 Ω models and the ZVC/E models with SWR bridges the noise level is higher by 6 dB.

Match ZVCE, ZVC page 13

(without system error correction)
Passive SWR bridges, 50 Ω

40 kHz ... 10 MHz > 10 dB
10 MHz ... 100 MHz > 16 dB

PORT BIAS 1/2 (inputs) page 14

Input impedance 10 kΩ

DC MEAS INPUTS DC 1/2 (DC measurement inputs) page 14

Voltage range -10 V...+10 V
Measurement uncertainty (U = measured voltage) 25 mV + 2.5 % · U
Input impedance > 10 kΩ

Increased Output Power for Port 1 option

page 16

Max. nominal output power

| | | |
|----------------------------|---------|-----------|
| ZVCE, ZVC with SWR bridges | PORT1 | OUTPUT a1 |
| 20 kHz to <u>2 GHz</u> | +6 dBm | +13 dBm |
| <u>2 GHz to 6 GHz</u> | +4 dBm | +11 dBm |
| 6 GHz to 8 GHz | +1 dBm | +11 dBm |
| ZVCE, ZVC with couplers | | |
| 20 kHz to <u>2 GHz</u> | +10 dBm | +13 dBm |
| <u>2 GHz to 6 GHz</u> | +8 dBm | +11 dBm |
| 6 GHz to 8 GHz | +5 dBm | +11 dBm |

Power linearity

page 16

| | | |
|--|-------------------|-----------------|
| ZVCE, ZVC with SWR bridges (referred to 0 dBm) | | |
| 20 kHz to <u>2 GHz</u> | +6 dBm to -9 dBm | < 0,4 dB |
| | -9 dBm to -17 dBm | < <u>0,8 dB</u> |
| <u>2 GHz to 6 GHz</u> | +4 dBm to -9 dBm | < 0,4 dB |
| | -9 dBm to -17 dBm | < <u>0,8 dB</u> |
| 6 GHz to 8 GHz | +1 dBm to -9 dBm | < 0,4 dB |
| | -9 dBm to -17 dBm | < <u>0,8 dB</u> |
| ZVCE, ZVC with couplers (referred to 0 dBm) | | |
| 20 kHz to <u>2 GHz</u> | +10 dBm to -5 dBm | < 0,4 dB |
| | -5 dBm to -15 dBm | < <u>0,8 dB</u> |
| <u>2 GHz to 6 GHz</u> | +8 dBm to -5 dBm | < 0,4 dB |
| | -5 dBm to -15 dBm | < <u>0,8 dB</u> |
| 6 GHz to 8 GHz | +5 dBm to -5 dBm | < 0,4 dB |
| | -5 dBm to -15 dBm | < <u>0,8 dB</u> |

Harmonics

page 16

At max. output power

20 kHz to 4 GHz -20 dBc

At output powers +3 dBm and 0 dBm
the specifications are cancelled

At output power 10 dB less than max. output power < -30 dBc

Spurious

page 16

>300 kHz from carrier < -40 dBc

Data sheet PD 757.5543.22 (ZVM, ZVK) number 11/00

| | | | | |
|--|------------|------------|------------|---------------|
| Dynamic range (without system error correction, without optional attenuator) | | | | page 8 |
| | ZVM | ZVM | ZVK | ZVK |
| at IF bandwidth of | 10 Hz | 10 kHz | 10 Hz | 10 kHz |
| up to <u>150 MHz</u> | > 75 dB | > 45 dB | > 70 dB | > 40 dB |
| <u>150 MHz to 500 MHz</u> | > 105 dB | > 75 dB | > 100 dB | > 70 dB |

| | |
|---|---------------------|
| ZVK uncertainty of transmission measurements | page 8 |
| after system error correction | |
| 28 GHz to 40 GHz | |
| for -10 dB to -25 dB..... | <u>0,2 dB</u> or 3° |

| | |
|---|---------------|
| ZVM Output power - Linearity (referred to -10 dBm) | page 9 |
| above 150 MHz <u>up to 14 GHz</u> in temperature range 20 °C to 26 °C | |
| for +15 dB to -10 dB..... | <0,4 dB |

| | |
|---|---------------|
| ZVK Output power - Linearity (referred to -10 dBm) | page 9 |
| above 150 MHz in temperature range 20 °C to 26 °C | |
| <u>for +10 dB to +5 dB</u> | <0,6 dB |
| for +5 dB to -10 dB..... | <0,4 dB |

| | | |
|---------------------------------|---------------------|------------|
| Harmonics | Seite 9 | |
| At maximum nominal source power | ZVM | ZVK |
| up to 10 GHz | <u>< -20 dBc</u> | < -20 dBc |
| 10 GHz to 20 GHz | <u>< -15 dBc</u> | < -15 dBc |

| | |
|---------------------------------|---------------|
| Spurious | page 9 |
| <u>>300 kHz from carrier</u> | |
| ZVM <u>up to 16 GHz</u> | < -35 dBc |
| <u>ZVM above 16 GHz</u> | < -30 dBc |
| ZVK <u>up to 16 GHz</u> | < -35 dBc |
| <u>ZVK above 16 GHz</u> | < -30 dBc |

| | |
|--|---------------|
| RMS noise level at IF bandwidth 10 Hz | page 9 |
| up to 500 MHz | < -70 dBm |

| | |
|--|----------------|
| PORT BIAS 1/2 (DC bias inputs for PORT 1/2) | page 14 |
| <u>Input impedance</u> | <u>10 kΩ</u> |

Important Hints before Operation:

For all instruments:

- The directory C:\R_S\INSTR and its subdirectories are reserved for system software. Never modify this directory in any way, otherwise the functioning of the instrument will be impaired.
- Aborting a hardcopy is not possible when printout is in progress. Print jobs in the queue can be deleted before printout has been started by pressing the HARDCOPY START key until the message "Hardcopy in progress. Abort?" is displayed. The length of the queue is two jobs.
- To avoid damage of electronic components of the DUT and the analyzer, the operational site must be protected against electrostatic discharge.

Windows NT



Caution:

The drivers and programs used under Windows NT are adapted to the measuring instrument. In order to prevent the instrument functions from damage, the settings should only be modified as described below. Existing software may only be modified using update software released by Rohde&Schwarz. Additionally only programs authorized by Rohde&Schwarz for use on the ZVx may be run on the instrument.

Do not power down during booting. Such a switch-off may lead to corruption of the hard disk files.

Removable Harddisk FSE-B18

When using the *Removable Harddisk, FSE-B18*, please observe the following:

- Always keep your *Removable Harddisk* in the plastic case included in this package.
- Do not drop your *Removable Harddisk*.
- Do not expose it to moisture, to extreme temperatures, or to a strong magnetic field.
- Do not squeeze the external cover of the *Removable Harddisk*.
- Do not affix additional labels.
- Do not remove the existing label or write anything on to it.

Patent Information

This product contains technology licensed by Marconi Instruments LTD. under US patents 4609881 and 4870384 and under corresponding patents in Germany and elsewhere.

Please note the safety instructions on the next sheet !



Before putting the product into operation for the first time, make sure to read the following



Safety Instructions

Rohde & Schwarz makes every effort to keep the safety standard of its products up to date and to offer its customers the highest possible degree of safety. Our products and the auxiliary equipment required for them are designed and tested in accordance with the relevant safety standards. Compliance with these standards is continuously monitored by our quality assurance system. This product has been designed and tested in accordance with the EC Certificate of Conformity and has left the manufacturer's plant in a condition fully complying with safety standards. To maintain this condition and to ensure safe operation, observe all instructions and warnings provided in this manual. If you have any questions regarding these safety instructions, Rohde & Schwarz will be happy to answer them.

Furthermore, it is your responsibility to use the product in an appropriate manner. This product is designed for use solely in industrial and laboratory environments or in the field and must not be used in any way that may cause personal injury or property damage. You are responsible if the product is used for an intention other than its designated purpose or in disregard of the manufacturer's instructions. The manufacturer shall assume no responsibility for such use of the product.

The product is used for its designated purpose if it is used in accordance with its operating manual and within its performance limits (see data sheet, documentation, the following safety instructions). Using the products requires technical skills and knowledge of English. It is therefore essential that the products be used exclusively by skilled and specialized staff or thoroughly trained personnel with the required skills. If personal safety gear is required for using Rohde & Schwarz products, this will be indicated at the appropriate place in the product documentation.

Symbols and safety labels

| | | | | | | | |
|--------------------------------|------------------------------------|--------------------------|----------------------|-------------|--------|-----------------|--|
| | | | | | | | |
| Observe operating instructions | Weight indication for units >18 kg | Danger of electric shock | Warning! Hot surface | PE terminal | Ground | Ground terminal | Attention! Electrostatic sensitive devices |

| | | | | | |
|-----------------------|--------------------|---------------------|--------------------------|------------------------------------|--|
| | | | | | |
| Supply voltage ON/OFF | Standby indication | Direct current (DC) | Alternating current (AC) | Direct/alternating current (DC/AC) | Device fully protected by double/reinforced insulation |

Safety Instructions

Observing the safety instructions will help prevent personal injury or damage of any kind caused by dangerous situations. Therefore, carefully read through and adhere to the following safety instructions before putting the product into operation. It is also absolutely essential to observe the additional safety instructions on personal safety that appear in other parts of the documentation. In these safety instructions, the word "product" refers to all merchandise sold and distributed by Rohde & Schwarz, including instruments, systems and all accessories.

Tags and their meaning

| | |
|-----------|--|
| DANGER | This tag indicates a safety hazard with a high potential of risk for the user that can result in death or serious injuries. |
| WARNING | This tag indicates a safety hazard with a medium potential of risk for the user that can result in death or serious injuries. |
| CAUTION | This tag indicates a safety hazard with a low potential of risk for the user that can result in slight or minor injuries. |
| ATTENTION | This tag indicates the possibility of incorrect use that can cause damage to the product. |
| NOTE | This tag indicates a situation where the user should pay special attention to operating the product but which does not lead to damage. |

These tags are in accordance with the standard definition for civil applications in the European Economic Area. Definitions that deviate from the standard definition may also exist. It is therefore essential to make sure that the tags described here are always used only in connection with the associated documentation and the associated product. The use of tags in connection with unassociated products or unassociated documentation can result in misinterpretations and thus contribute to personal injury or material damage.

Basic safety instructions

1. The product may be operated only under the operating conditions and in the positions specified by the manufacturer. Its ventilation must not be obstructed during operation. Unless otherwise specified, the following requirements apply to Rohde & Schwarz products:
prescribed operating position is always with the housing floor facing down, IP protection 2X, pollution severity 2, overvoltage category 2, use only in enclosed spaces, max. operation altitude max. 2000 m. Unless specified otherwise in the data sheet, a tolerance of $\pm 10\%$ shall apply to the nominal voltage and of $\pm 5\%$ to the nominal frequency.
2. Applicable local or national safety regulations and rules for the prevention of accidents must be observed in all work performed. The product may be opened only by authorized, specially trained personnel. Prior to performing any work on the product or opening the product, the product must be disconnected from the supply network. Any adjustments, replacements of parts, maintenance or repair must be carried out only by technical personnel authorized by Rohde & Schwarz. Only original parts may be used for replacing parts relevant to safety (e.g. power switches, power transformers, fuses). A safety test must always be performed after parts relevant to safety have been replaced (visual inspection, PE conductor test, insulation resistance measurement, leakage current measurement, functional test).
3. As with all industrially manufactured goods, the use of substances that induce an allergic reaction (allergens, e.g. nickel) such as aluminum cannot be generally excluded. If you develop an allergic reaction (such as a skin rash, frequent sneezing, red eyes or respiratory difficulties), consult a physician immediately to determine the cause.

Safety Instructions

4. If products/components are mechanically and/or thermally processed in a manner that goes beyond their intended use, hazardous substances (heavy-metal dust such as lead, beryllium, nickel) may be released. For this reason, the product may only be disassembled, e.g. for disposal purposes, by specially trained personnel. Improper disassembly may be hazardous to your health. National waste disposal regulations must be observed.
5. If handling the product yields hazardous substances or fuels that must be disposed of in a special way, e.g. coolants or engine oils that must be replenished regularly, the safety instructions of the manufacturer of the hazardous substances or fuels and the applicable regional waste disposal regulations must be observed. Also observe the relevant safety instructions in the product documentation.
6. Depending on the function, certain products such as RF radio equipment can produce an elevated level of electromagnetic radiation. Considering that unborn life requires increased protection, pregnant women should be protected by appropriate measures. Persons with pacemakers may also be endangered by electromagnetic radiation. The employer is required to assess workplaces where there is a special risk of exposure to radiation and, if necessary, take measures to avert the danger.
7. Operating the products requires special training and intense concentration. Make certain that persons who use the products are physically, mentally and emotionally fit enough to handle operating the products; otherwise injuries or material damage may occur. It is the responsibility of the employer to select suitable personnel for operating the products.
8. Prior to switching on the product, it must be ensured that the nominal voltage setting on the product matches the nominal voltage of the AC supply network. If a different voltage is to be set, the power fuse of the product may have to be changed accordingly.
9. In the case of products of safety class I with movable power cord and connector, operation is permitted only on sockets with earthing contact and protective earth connection.
10. Intentionally breaking the protective earth connection either in the feed line or in the product itself is not permitted. Doing so can result in the danger of an electric shock from the product. If extension cords or connector strips are implemented, they must be checked on a regular basis to ensure that they are safe to use.
11. If the product has no power switch for disconnection from the AC supply, the plug of the connecting cable is regarded as the disconnecting device. In such cases, it must be ensured that the power plug is easily reachable and accessible at all times (length of connecting cable approx. 2 m). Functional or electronic switches are not suitable for providing disconnection from the AC supply. If products without power switches are integrated in racks or systems, a disconnecting device must be provided at the system level.
12. Never use the product if the power cable is damaged. By taking appropriate safety measures and carefully laying the power cable, ensure that the cable cannot be damaged and that no one can be hurt by e.g. tripping over the cable or suffering an electric shock.
13. The product may be operated only from TN/TT supply networks fused with max. 16 A.
14. Do not insert the plug into sockets that are dusty or dirty. Insert the plug firmly and all the way into the socket. Otherwise this can result in sparks, fire and/or injuries.
15. Do not overload any sockets, extension cords or connector strips; doing so can cause fire or electric shocks.
16. For measurements in circuits with voltages $V_{rms} > 30\text{ V}$, suitable measures (e.g. appropriate measuring equipment, fusing, current limiting, electrical separation, insulation) should be taken to avoid any hazards.
17. Ensure that the connections with information technology equipment comply with IEC 950/EN 60950.
18. Never remove the cover or part of the housing while you are operating the product. This will expose circuits and components and can lead to injuries, fire or damage to the product.

Safety Instructions

19. If a product is to be permanently installed, the connection between the PE terminal on site and the product's PE conductor must be made first before any other connection is made. The product may be installed and connected only by a skilled electrician.
20. For permanently installed equipment without built-in fuses, circuit breakers or similar protective devices, the supply circuit must be fused in such a way that suitable protection is provided for users and products.
21. Do not insert any objects into the openings in the housing that are not designed for this purpose. Never pour any liquids onto or into the housing. This can cause short circuits inside the product and/or electric shocks, fire or injuries.
22. Use suitable overvoltage protection to ensure that no overvoltage (such as that caused by a thunderstorm) can reach the product. Otherwise the operating personnel will be endangered by electric shocks.
23. Rohde & Schwarz products are not protected against penetration of water, unless otherwise specified (see also safety instruction 1.). If this is not taken into account, there exists the danger of electric shock or damage to the product, which can also lead to personal injury.
24. Never use the product under conditions in which condensation has formed or can form in or on the product, e.g. if the product was moved from a cold to a warm environment.
25. Do not close any slots or openings on the product, since they are necessary for ventilation and prevent the product from overheating. Do not place the product on soft surfaces such as sofas or rugs or inside a closed housing, unless this is well ventilated.
26. Do not place the product on heat-generating devices such as radiators or fan heaters. The temperature of the environment must not exceed the maximum temperature specified in the data sheet.
27. Batteries and storage batteries must not be exposed to high temperatures or fire. Keep batteries and storage batteries away from children. If batteries or storage batteries are improperly replaced, this can cause an explosion (warning: lithium cells). Replace the battery or storage battery only with the matching Rohde & Schwarz type (see spare parts list). Batteries and storage batteries are hazardous waste. Dispose of them only in specially marked containers. Observe local regulations regarding waste disposal. Do not short-circuit batteries or storage batteries.
28. Please be aware that in the event of a fire, toxic substances (gases, liquids etc.) that may be hazardous to your health may escape from the product.
29. Please be aware of the weight of the product. Be careful when moving it; otherwise you may injure your back or other parts of your body.
30. Do not place the product on surfaces, vehicles, cabinets or tables that for reasons of weight or stability are unsuitable for this purpose. Always follow the manufacturer's installation instructions when installing the product and fastening it to objects or structures (e.g. walls and shelves).
31. Handles on the products are designed exclusively for personnel to hold or carry the product. It is therefore not permissible to use handles for fastening the product to or on means of transport such as cranes, fork lifts, wagons, etc. The user is responsible for securely fastening the products to or on the means of transport and for observing the safety regulations of the manufacturer of the means of transport. Noncompliance can result in personal injury or material damage.
32. If you use the product in a vehicle, it is the sole responsibility of the driver to drive the vehicle safely. Adequately secure the product in the vehicle to prevent injuries or other damage in the event of an accident. Never use the product in a moving vehicle if doing so could distract the driver of the vehicle. The driver is always responsible for the safety of the vehicle; the manufacturer assumes no responsibility for accidents or collisions.
33. If a laser product (e.g. a CD/DVD drive) is integrated in a Rohde & Schwarz product, do not use any other settings or functions than those described in the documentation. Otherwise this may be hazardous to your health, since the laser beam can cause irreversible damage to your eyes. Never try to take such products apart, and never look into the laser beam.



Por favor lea imprescindiblemente antes de la primera puesta en funcionamiento las siguientes informaciones de seguridad



Informaciones de seguridad

Es el principio de Rohde & Schwarz de tener a sus productos siempre al día con los standards de seguridad y de ofrecer a sus clientes el máximo grado de seguridad. Nuestros productos y todos los equipos adicionales son siempre fabricados y examinados según las normas de seguridad vigentes. Nuestra sección de gestión de la seguridad de calidad controla constantemente que sean cumplidas estas normas. Este producto ha sido fabricado y examinado según el comprobante de conformidad adjunto según las normas de la CE y ha salido de nuestra planta en estado impecable según los standards técnicos de seguridad. Para poder preservar este estado y garantizar un funcionamiento libre de peligros, deberá el usuario atenerse a todas las informaciones, informaciones de seguridad y notas de alerta. Rohde&Schwarz está siempre a su disposición en caso de que tengan preguntas referentes a estas informaciones de seguridad.

Además queda en la responsabilidad del usuario utilizar el producto en la forma debida. Este producto solamente fue elaborado para ser utilizado en la industria y el laboratorio o para fines de campo y de ninguna manera deberá ser utilizado de modo que alguna persona/cosa pueda ser dañada. El uso del producto fuera de sus fines definidos o despreciando las informaciones de seguridad del fabricante queda en la responsabilidad del usuario. El fabricante no se hace en ninguna forma responsable de consecuencias a causa del maluso del producto.

Se parte del uso correcto del producto para los fines definidos si el producto es utilizado dentro de las instrucciones del correspondiente manual del uso y dentro del margen de rendimiento definido (ver hoja de datos, documentación, informaciones de seguridad que siguen). El uso de los productos hace necesarios conocimientos profundos y el conocimiento del idioma inglés. Por eso se deberá tener en cuenta de exclusivamente autorizar para el uso de los productos a personas péritas o debidamente minuciosamente instruidas con los conocimientos citados. Si fuera necesaria indumentaria de seguridad para el uso de productos de R&S, encontrará la información debida en la documentación del producto en el capítulo correspondiente.

Símbolos y definiciones de seguridad

| | | | | | | | |
|-------------------------------------|---|-------------------------------|-----------------------------------|--------------------------------|-------------------|----------------------------|---|
| | | | | | | | |
| Ver manual de instrucciones del uso | Informaciones para maquinaria con un peso de > 18kg | Peligro de golpe de corriente | ¡Advertencia! Superficie caliente | Conexión a conductor protector | Conexión a tierra | Conexión a masa conductora | ¡Cuidado! Elementos de construcción con peligro de carga electrostática |

| | | | | | |
|---------------------------|---------------------|-----------------------|----------------------|----------------------------------|--|
| | | | | | |
| potencia EN MARCHA/PARADA | Indicación Stand-by | Corriente continua DC | Corriente alterna AC | Corriente continua/alterna DC/AC | El aparato está protegido en su totalidad por un aislamiento de doble refuerzo |

Informaciones de seguridad

Tener en cuenta las informaciones de seguridad sirve para tratar de evitar daños y peligros de toda clase. Es necesario de que se lean las siguientes informaciones de seguridad concienzudamente y se tengan en cuenta debidamente antes de la puesta en funcionamiento del producto. También deberán ser tenidas en cuenta las informaciones para la protección de personas que encontrarán en otro capítulo de esta documentación y que también son obligatorias de seguir. En las informaciones de seguridad actuales hemos juntado todos los objetos vendidos por Rohde&Schwarz bajo la denominación de „producto“, entre ellos también aparatos, instalaciones así como toda clase de accesorios.

Palabras de señal y su significado

| | |
|-------------|--|
| PELIGRO | Indica un punto de peligro con gran potencial de riesgo para el usuario. Punto de peligro que puede llevar hasta la muerte o graves heridas. |
| ADVERTENCIA | Indica un punto de peligro con un potencial de riesgo mediano para el usuario. Punto de peligro que puede llevar hasta la muerte o graves heridas . |
| ATENCIÓN | Indica un punto de peligro con un potencial de riesgo pequeño para el usuario. Punto de peligro que puede llevar hasta heridas leves o pequeñas |
| CUIDADO | Indica la posibilidad de utilizar mal el producto y a consecuencia dañarlo. |
| INFORMACIÓN | Indica una situación en la que deberían seguirse las instrucciones en el uso del producto, pero que no consecuentemente deben de llevar a un daño del mismo. |

Las palabras de señal corresponden a la definición habitual para aplicaciones civiles en el ámbito de la comunidad económica europea. Pueden existir definiciones diferentes a esta definición. Por eso se debiera tener en cuenta que las palabras de señal aquí descritas sean utilizadas siempre solamente en combinación con la correspondiente documentación y solamente en combinación con el producto correspondiente. La utilización de las palabras de señal en combinación con productos o documentaciones que no les correspondan puede llevar a malinterpretaciones y tener por consecuencia daños en personas u objetos.

Informaciones de seguridad elementales

1. El producto solamente debe ser utilizado según lo indicado por el fabricante referente a la situación y posición de funcionamiento sin que se obstruya la ventilación. Si no se convino de otra manera, es para los productos R&S válido lo que sigue: como posición de funcionamiento se define principalmente la posición con el suelo de la caja para abajo , modo de protección IP 2X, grado de suciedad 2, categoría de sobrecarga eléctrica 2, utilizar solamente en estancias interiores, utilización hasta 2000 m sobre el nivel del mar.
A menos que se especifique otra cosa en la hoja de datos, se aplicará una tolerancia de $\pm 10\%$ sobre el voltaje nominal y de $\pm 5\%$ sobre la frecuencia nominal.
2. En todos los trabajos deberán ser tenidas en cuenta las normas locales de seguridad de trabajo y de prevención de accidentes. El producto solamente debe de ser abierto por personal périto autorizado. Antes de efectuar trabajos en el producto o abrirlo deberá este ser desconectado de la corriente. El ajuste, el cambio de partes, la manutención y la reparación deberán ser solamente efectuadas por electricistas autorizados por R&S. Si se reponen partes con importancia para los aspectos de seguridad (por ejemplo el enchufe, los transformadores o los fusibles), solamente podrán ser sustituidos por partes originales. Despues de cada recambio de partes elementales para la seguridad deberá ser efectuado un control de

Informaciones de seguridad

- seguridad (control a primera vista, control de conductor protector, medición de resistencia de aislamiento, medición de medición de la corriente conductora, control de funcionamiento).
3. Como en todo producto de fabricación industrial no puede ser excluido en general de que se produzcan al usarlo elementos que puedan generar alergias, los llamados elementos alergénicos (por ejemplo el níquel). Si se produjeran en el trato con productos R&S reacciones alérgicas, como por ejemplo urticaria, estornudos frecuentes, irritación de la conjuntiva o dificultades al respirar, se deberá consultar inmediatamente a un médico para averiguar los motivos de estas reacciones.
 4. Si productos / elementos de construcción son tratados fuera del funcionamiento definido de forma mecánica o térmica, pueden generarse elementos peligrosos (polvos de sustancia de metales pesados como por ejemplo plomo, berilio, níquel). La partición elemental del producto, como por ejemplo sucede en el tratamiento de materias residuales, debe de ser efectuada solamente por personal especializado para estos tratamientos. La partición elemental efectuada inadecuadamente puede generar daños para la salud. Se deben tener en cuenta las directivas nacionales referentes al tratamiento de materias residuales.
 5. En el caso de que se produjeran agentes de peligro o combustibles en la aplicación del producto que debieran de ser transferidos a un tratamiento de materias residuales, como por ejemplo agentes refrigerantes que deben ser repuestos en periodos definidos, o aceites para motores, deberán ser tenidas en cuenta las prescripciones de seguridad del fabricante de estos agentes de peligro o combustibles y las regulaciones regionales para el tratamiento de materias residuales. Cuiden también de tener en cuenta en caso dado las prescripciones de seguridad especiales en la descripción del producto.
 6. Ciertos productos, como por ejemplo las instalaciones de radiación HF, pueden a causa de su función natural, emitir una radiación electromagnética aumentada. En vista a la protección de la vida en desarrollo deberían ser protegidas personas embarazadas debidamente. También las personas con un bypass pueden correr peligro a causa de la radiación electromagnética. El empresario está comprometido a valorar y señalar áreas de trabajo en las que se corra un riesgo de exposición a radiaciones aumentadas de riesgo aumentado para evitar riesgos.
 7. La utilización de los productos requiere instrucciones especiales y una alta concentración en el manejo. Debe de ponerse por seguro de que las personas que manejen los productos estén a la altura de los requerimientos necesarios referente a sus aptitudes físicas, psíquicas y emocionales, ya que de otra manera no se pueden excluir lesiones o daños de objetos. El empresario lleva la responsabilidad de seleccionar el personal usuario apto para el manejo de los productos.
 8. Antes de la puesta en marcha del producto se deberá tener por seguro de que la tensión preseleccionada en el producto equivalga a la del la red de distribución. Si es necesario cambiar la preselección de la tensión también se deberán en caso dabo cambiar los fusibles correspondientes del producto.
 9. Productos de la clase de seguridad I con alimentación móvil y enchufe individual de producto solamente deberán ser conectados para el funcionamiento a tomas de corriente de contacto de seguridad y con conductor protector conectado.
 10. Queda prohibida toda clase de interrupción intencionada del conductor protector, tanto en la toma de corriente como en el mismo producto ya que puede tener como consecuencia el peligro de golpe de corriente por el producto. Si se utilizaran cables o enchufes de extensión se deberá poner al seguro, que es controlado su estado técnico de seguridad.
 11. Si el producto no está equipado con un interruptor para desconectarlo de la red, se deberá considerar el enchufe del cable de distribución como interruptor. En estos casos deberá asegurar de que el enchufe sea de fácil acceso y nabejo (medida del cable de distribución aproximadamente 2 m). Los interruptores de función o electrónicos no son aptos para el corte de la red eléctrica. Si los productos sin interruptor están integrados en construcciones o instalaciones, se deberá instalar el interruptor al nivel de la instalación.

Informaciones de seguridad

12. No utilice nunca el producto si está dañado el cable eléctrico. Asegure a través de las medidas de protección y de instalación adecuadas de que el cable de eléctrico no pueda ser dañado o de que nadie pueda ser dañado por él, por ejemplo al tropezar o por un golpe de corriente.
13. Solamente está permitido el funcionamiento en redes de distribución TN/TT aseguradas con fusibles de como máximo 16 A.
14. Nunca conecte el enchufe en tomas de corriente sucias o llenas de polvo. Introduzca el enchufe por completo y fuertemente en la toma de corriente. Si no tiene en consideración estas indicaciones se arriesga a que se originen chispas, fuego y/o heridas.
15. No sobrecargue las tomas de corriente, los cables de extensión o los enchufes de extensión ya que esto pudiera causar fuego o golpes de corriente.
16. En las mediciones en circuitos de corriente con una tensión de entrada de $U_{eff} > 30 \text{ V}$ se deberá tomar las precauciones debidas para impedir cualquier peligro (por ejemplo medios de medición adecuados, seguros, limitación de tensión, corte protector, aislamiento etc.).
17. En caso de conexión con aparatos de la técnica informática se deberá tener en cuenta que estos cumplan los requisitos de la EC950/EN60950.
18. Nunca abra la tapa o parte de ella si el producto está en funcionamiento. Esto pone a descubierto los cables y componentes eléctricos y puede causar heridas, fuego o daños en el producto.
19. Si un producto es instalado fijamente en un lugar, se deberá primero conectar el conductor protector fijo con el conductor protector del aparato antes de hacer cualquier otra conexión. La instalación y la conexión deberán ser efectuadas por un electricista especializado.
20. En caso de que los productos que son instalados fijamente en un lugar sean sin protector implementado, autointerruptor o similares objetos de protección, deberá la toma de corriente estar protegida de manera que los productos o los usuarios estén suficientemente protegidos.
21. Por favor, no introduzca ningún objeto que no esté destinado a ello en los orificios de la caja del aparato. No vierta nunca ninguna clase de líquidos sobre o en la caja. Esto puede producir corto circuitos en el producto y/o puede causar golpes de corriente, fuego o heridas.
22. Asegúrese con la protección adecuada de que no pueda originarse en el producto una sobrecarga por ejemplo a causa de una tormenta. Si no se verá el personal que lo utilice expuesto al peligro de un golpe de corriente.
23. Los productos R&S no están protegidos contra el agua si no es que exista otra indicación, ver también punto 1. Si no se tiene en cuenta esto se arriesga el peligro de golpe de corriente o de daños en el producto lo cual también puede llevar al peligro de personas.
24. No utilice el producto bajo condiciones en las que pueda producirse y se hayan producido líquidos de condensación en o dentro del producto como por ejemplo cuando se desplaza el producto de un lugar frío a un lugar caliente.
25. Por favor no cierre ninguna ranura u orificio del producto, ya que estas son necesarias para la ventilación e impiden que el producto se caliente demasiado. No pongan el producto encima de materiales blandos como por ejemplo sofás o alfombras o dentro de una caja cerrada, si esta no está suficientemente ventilada.
26. No ponga el producto sobre aparatos que produzcan calor, como por ejemplo radiadores o calentadores. La temperatura ambiental no debe superar la temperatura máxima especificada en la hoja de datos.

Informaciones de seguridad

27. Baterías y acumuladores no deben de ser expuestos a temperaturas altas o al fuego. Guardar baterías y acumuladores fuera del alcance de los niños. Si las baterías o los acumuladores no son cambiados con la debida atención existirá peligro de explosión (atención celulas de Litio). Cambiar las baterías o los acumuladores solamente por los del tipo R&S correspondiente (ver lista de piezas de recambio). Baterías y acumuladores son deshechos problemáticos. Por favor tirenlos en los recipientes especiales para este fin. Por favor tengan en cuenta las prescripciones nacionales de cada país referente al tratamiento de deshechos. Nunca sometan las baterías o acumuladores a un corto circuito.
28. Tengan en consideración de que en caso de un incendio pueden escaparse gases tóxicos del producto, que pueden causar daños a la salud.
29. Por favor tengan en cuenta que en caso de un incendio pueden desprenderse del producto agentes venenosos (gases, líquidos etc.) que pueden generar daños a la salud.
30. No sitúe el producto encima de superficies, vehículos, estantes o mesas, que por sus características de peso o de estabilidad no sean aptas para él. Siga siempre las instrucciones de instalación del fabricante cuando instale y asegure el producto en objetos o estructuras (por ejemplo paredes y estantes).
31. Las asas instaladas en los productos sirven solamente de ayuda para el manejo que solamente está previsto para personas. Por eso no está permitido utilizar las asas para la sujecion en o sobre medios de transporte como por ejemplo grúas, carretillas elevadoras de horquilla, carros etc. El usuario es responsable de que los productos sean sujetados de forma segura a los medios de transporte y de que las prescripciones de seguridad del fabricante de los medios de transporte sean tenidas en cuenta. En caso de que no se tengan en cuenta pueden causarse daños en personas y objetos.
32. Si llega a utilizar el producto dentro de un vehículo, queda en la responsabilidad absoluta del conductor que conducir el vehículo de manera segura. Asegure el producto dentro del vehículo debidamente para evitar en caso de un accidente las lesiones u otra clase de daños. No utilice nunca el producto dentro de un vehículo en movimiento si esto pudiera distraer al conductor. Siempre queda en la responsabilidad absoluta del conductor la seguridad del vehículo y el fabricante no asumirá ninguna clase de responsabilidad por accidentes o colisiones.
33. Dado el caso de que esté integrado un producto de laser en un producto R&S (por ejemplo CD/DVD-ROM) no utilice otras instalaciones o funciones que las descritas en la documentación. De otra manera pondrá en peligro su salud, ya que el rayo laser puede dañar irreversiblemente sus ojos. Nunca trate de descomponer estos productos. Nunca mire dentro del rayo laser.



Certificate No.: 2000-05, page 1

This is to certify that:

| Equipment type | Stock No. | Designation |
|----------------|----------------------|-------------------------|
| ZVC | 1127.8600.60/.61/.62 | Vector Network Analyzer |
| ZVCE | 1127.8600.50/.51/.52 | |
| ZVK | 1127.8651.60 | |
| ZVM | 1127.8500.60 | |
| ZVR | 1127.8551.61/.62 | |
| ZVRE | 1127.8551.51/.52/.55 | |
| ZVRL | 1127.8551.41 | |

complies with the provisions of the Directive of the Council of the European Union on the approximation of the laws of the Member States

- relating to electrical equipment for use within defined voltage limits
(73/23/EEC revised by 93/68/EEC)
- relating to electromagnetic compatibility
(89/336/EEC revised by 91/263/EEC, 92/31/EEC, 93/68/EEC)

Conformity is proven by compliance with the following standards:

EN61010-1 : 1993 + A2 : 1995
EN55011 : 1998 + A1 : 1999, Klasse B
EN61000-3-2 : 1995 + A1 : 1998 + A2 : 1998 + A14 : 2000
EN61000-3-3 : 1995
EN50082-2 : 1995

Affixing the EC conformity mark as from 2000

Munich, 2001-01-30

ROHDE & SCHWARZ GmbH & Co. KG
Mühldorfstr. 15, D-81671 München

Central Quality Management FS-QZ / Becker



Certificate No.: 2000-05, page 2

This is to certify that:

| Equipment type | Stock No. | Designation |
|----------------|------------------|---------------------------------------|
| ZVK-B21 | 1128.1409.11 | Attenuator for Generator Port 1 |
| ZVK-B22 | 1128.1409.21 | Attenuator for Generator Port 2 |
| ZVK-B23 | 1128.1409.12 | Attenuator for Receiver Port 1 |
| ZVK-B24 | 1128.1409.22 | Attenuator for Receiver Port 2 |
| ZVM-B21 | 1128.1009.11 | Attenuator for Generator Port 1 |
| ZVM-B22 | 1128.1009.21 | Attenuator for Generator Port 2 |
| ZVM-B23 | 1128.1009.12 | Attenuator for Receiver Port 1 |
| ZVM-B24 | 1128.1009.22 | Attenuator for Receiver Port 2 |
| ZVR-B1 | 1044.0625.02 | Autokal, Automatic Calibration System |
| ZVR-B2 | 1044.1009.02 | Time Domain |
| ZVR-B8 | 1086.0000.02 | 3-Port Adapter |
| ZVR-B10 | 1106.6495.xx | Increased Output Power at Port 1 |
| ZVR-B14 | 1106.7510.02/.03 | 4-Port Adapter |
| ZVR-B21 | 1044.0025.11 | Attenuator for Generator Port 1 |
| ZVR-B22 | 1044.0025.21 | Attenuator for Generator Port 2 |
| ZVR-B23 | 1044.0025.12/.31 | Attenuator for Receiver Port 1 |
| ZVR-B24 | 1044.0025.22/.42 | Attenuator for Receiver Port 2 |
| ZVR-B26 | 1106.8600.07 | Extra Inputs 4 Port |
| FSE-B16 | 1073.5973.02/.03 | Ethernet Interface |
| FSE-B17 | 1066.4017.02 | Second IEC BUS Interface |

complies with the provisions of the Directive of the Council of the European Union on the approximation of the laws of the Member States

- relating to electrical equipment for use within defined voltage limits
(73/23/EEC revised by 93/68/EEC)
- relating to electromagnetic compatibility
(89/336/EEC revised by 91/263/EEC, 92/31/EEC, 93/68/EEC)

Conformity is proven by compliance with the following standards:

EN61010-1 : 1993 + A2 : 1995
EN55011 : 1998 + A1 : 1999, Klasse B
EN61000-3-2 : 1995 + A1 : 1998 + A2 : 1998 + A14 : 2000
EN61000-3-3 : 1995
EN50082-2 : 1995

Affixing the EC conformity mark as from 2000

ROHDE & SCHWARZ GmbH & Co. KG
Mühldorfstr. 15, D-81671 München

Munich, 2001-01-30

Central Quality Management FS-QZ / Becker

1 Preparation for Use

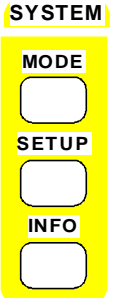
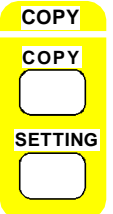
1.1 Introduction

The following chapter describes the position of the controls and sockets of a network analyzer of the ZVR family via the views of the front and rear panels. It shows step by step how the instrument is started and set up. The chapter also describes how a mouse, an external keyboard and a printer can be connected.

1.2 Legend for Front and Rear View

1.2.1 Front View ZVR, ZVK and ZVM

1.2.1.1 Front View ZVR

| | | |
|---|--|---|
| 1 | | |
| | 3 1/2" floppy disk drive | |
| 2 SYSTEM | | |
|  | <p>Initial instrument setup</p> <p>MODE Select operating mode</p> <p>SETUP Define default settings and interface configurations</p> <p>INFO Information on version number of hardware and firmware, installed options and recorded system messages</p> | <p>See chapter 2, section 2.2 and section 2.4</p> |
| 3 COPY | | |
|  | <p>Printer and plotter setup</p> <p>COPY Start a print job with the setup defined in the SETTING menu</p> <p>SETTING Configure output of measurement diagrams to various output media</p> | <p>See chapter 2, sections 2.2 and 2.5</p> |
| 4 | | |
| | Display | <p>See chapter 2, section 2.3.1</p> |

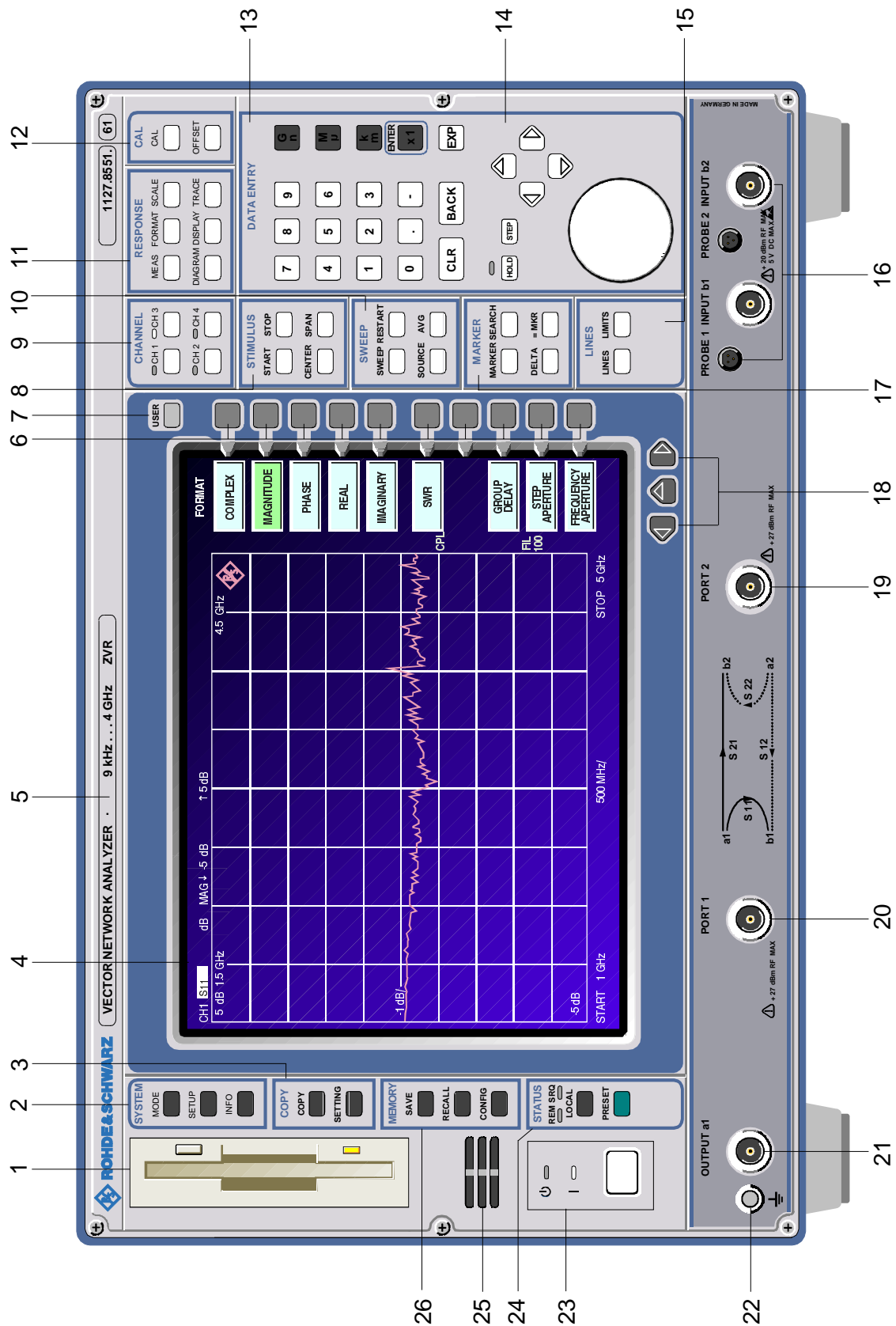


Fig. 1-1 Front view ZVR

5

Designation, frequency range and Order No. Of device:

e. g.

ZVR 9 kHz ... 4 GHz 1127.8551.61

6

Softkeys

See chapter 2, sections 2.3.1.2 and 2.3.4

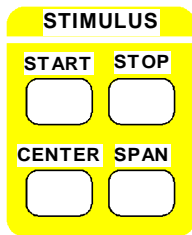
7 USER



Writing keyboard macros

See chapter 2, section 2.8

8 STIMULUS

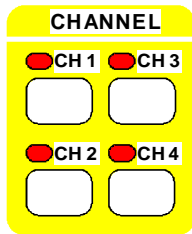


Setting the sweep limits

- START start frequency
- STOP stop frequency
- CENTER center frequency
- SPAN sweep width

See chapter 2, section 2.9

9 CHANNEL

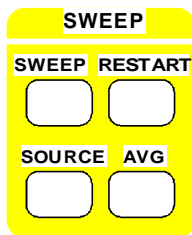


Selecting the active display channel which is indicated by the corresponding LED.

LEDs signal the selected channels.

See chapter 2, section 2.13

10 SWEEP



Entry of sweep parameters

- SWEEP Define sweep settings
- RESTART Start a new sweep
- SOURCE Set fixed parameters
- AVG Set receiver bandwidth for the measurement and select averaging mode

See chapter 2, sections 2.2 and 2.10

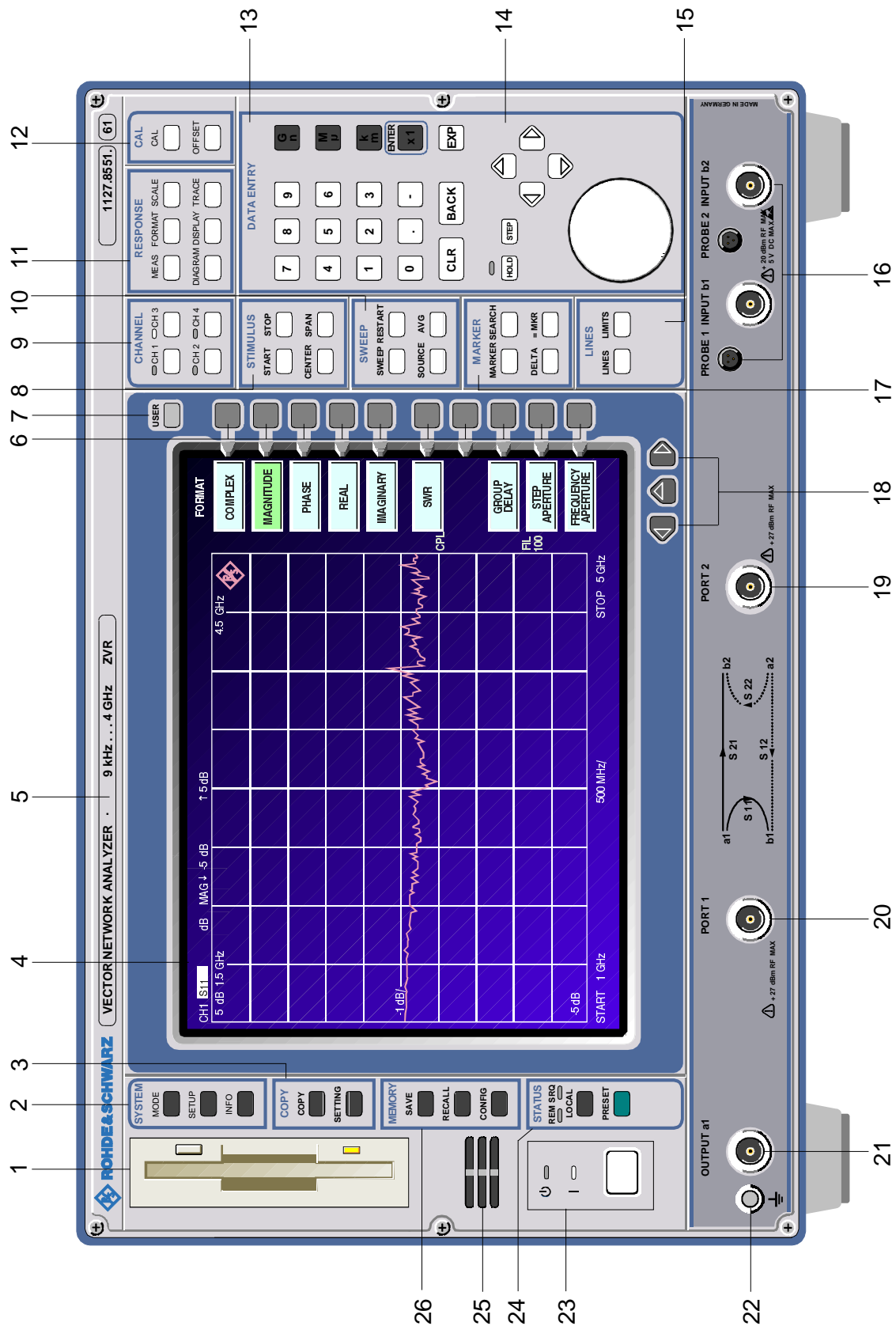
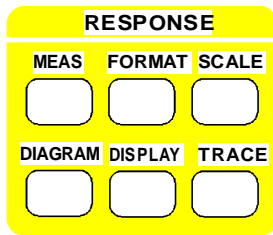


Fig. 1-1 Front view ZVR

11 RESPONSE



- Configuration of result display
- MEAS Select measurement unit
- FORMAT Format measurement unit
- SCALE Select scale of measurement diagram
- DIAGRAM Select the result diagram
- DISPLAY Configure the display
- TRACE Measure using the trace display

See chapter 2, sections 2.2 and 2.14

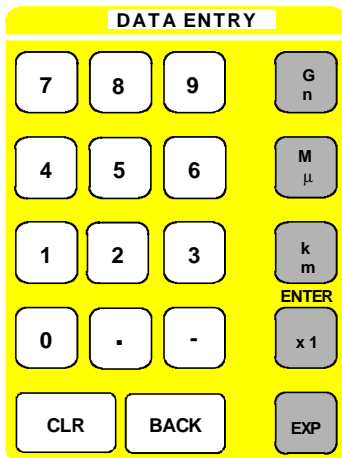
12 CAL



- Correction of system errors
- CAL Calibrate
- OFFSET Enter offset values

See chapter 2, sections 2.2 and 2.15

13 DATA ENTRY



- Keypad for entering data
- 0 to 9 Enter numerals
- . Enter decimal point
- Change sign
- CLR
 - Close entry field (if no entry was made or the entry was not completed, the original setting is retained)
 - Clear a new (started) entry
 - Close the message window (with status and error messages or warnings)
- BACK Clear the last character entered
- G**
n The units prefix key closes the entry and define the multiplication factor for the basic unit. For dimensionless or alphanumeric entries the units prefix keys have the validity 1 and assume the function of the ENTER key. G/n switches over between different table levels (sub-tables)
- M**
μ
- k**
m
- x 1 Append an exponent
- EXP

See chapter 2, section 2.3.6

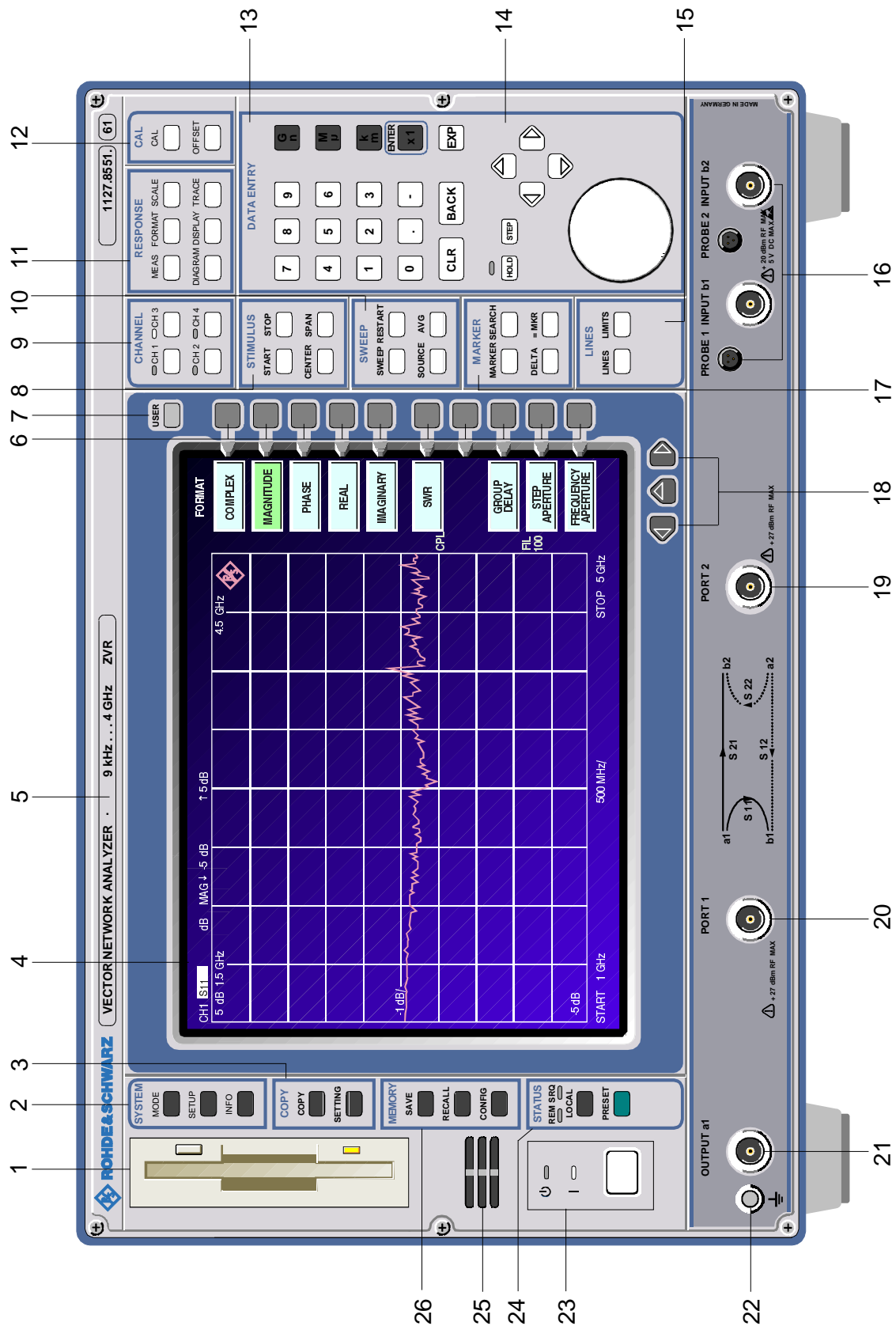
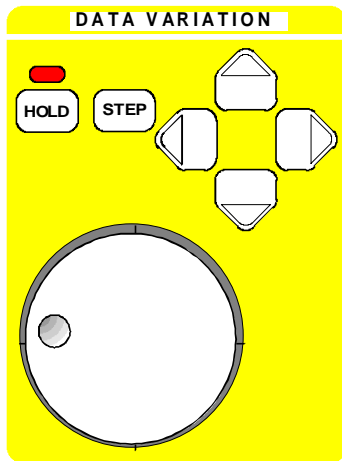


Fig. 1-1 Front view ZVR

14 DATA VARIATION



Keys for varying data and cursor movement

HOLD Disable control elements or overall instrument control.
LED signals the hold condition.

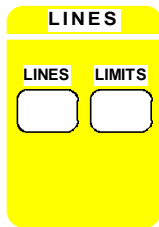
STEP Set step size for the cursor keys or rollkey.

Cursor keys – Move cursor within the entry fields and tables
– Vary entered value
– Define the direction of movement for the rollkey

Rollkey – Vary entered value
– Move markers and limits
– Select characters in the help line editor
– Move cursors in the tables

See chapter 2, section 2.3.6, 2.3.7, 2.3.8

15 LINES



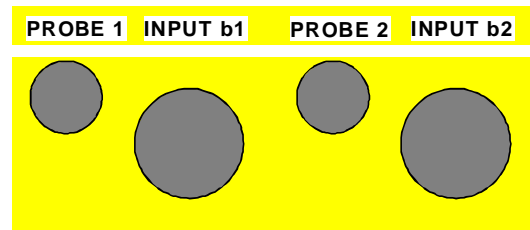
Setting evaluation lines and tolerance limits

LINES Evaluation lines

LIMITS Tolerance limits

See chapter 2, sections 2.2 and 2.12

16



Additional receiver input (N-sockets INPUT b1 and INPUT b2)

Probes supply connectors PROBE 1 and PROBE 2

available with option ZVR-B25, "External measurements"

See chapter 2.4.1.2 (*External Measurements*) and Appendix A

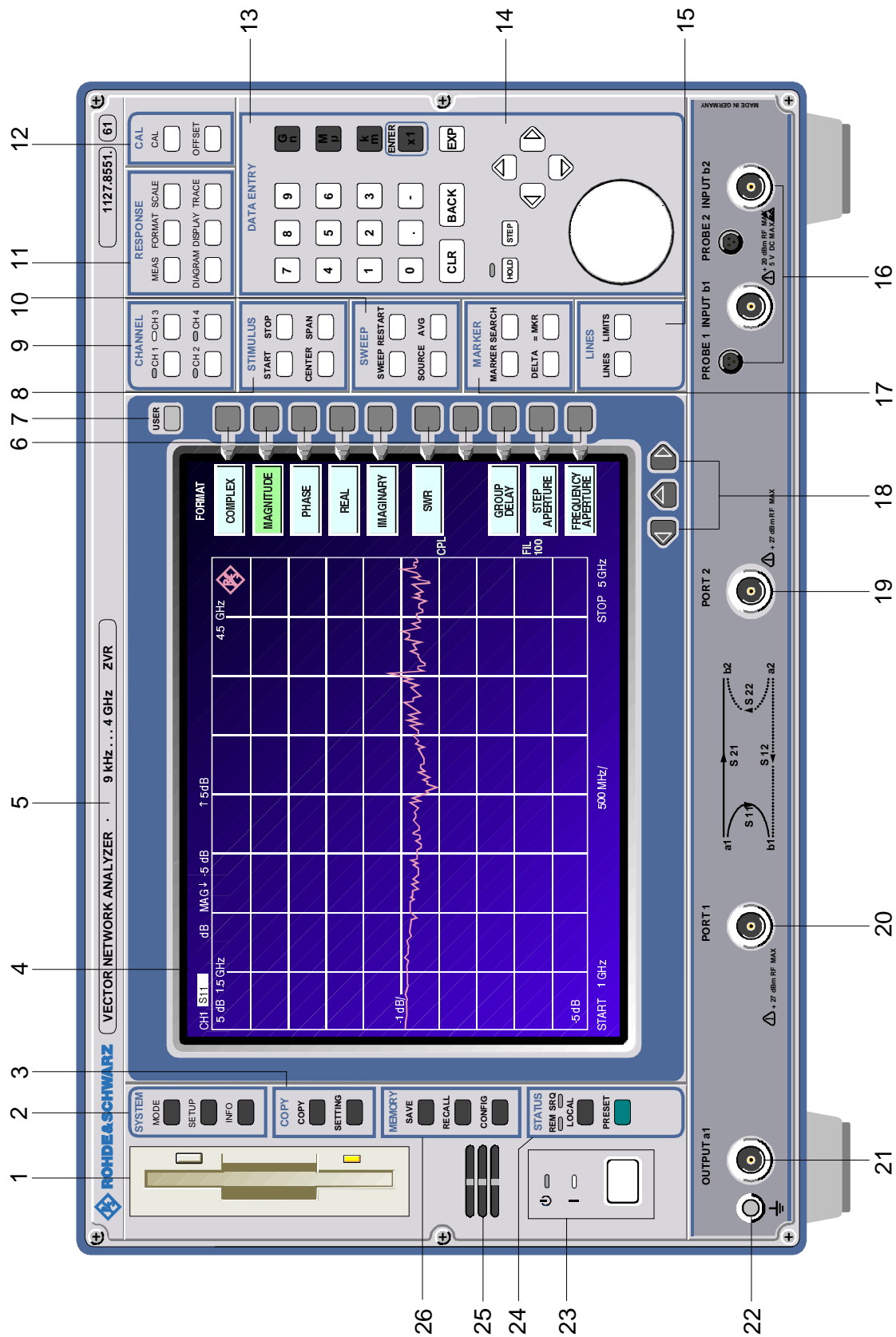






Fig. 1-1 Front view ZVR

17 MARKER

| | | |
|----------------------|--|--------------------------------------|
| MARKER | Selecting and setting markers | See chapter 2, sections 2.2 and 2.11 |
| MARKER SEARCH | MARKER Select and set main markers | |
| DELTA = MKR | SEARCH Marker search functions | |
| DELTA | DELTA Select and set the delta markers | |
| = MKR | = MKR Take over the active marker position for sweep setting or scaling | |

18

| | | |
|---|----------------------|------------------------------|
|  | Menu change keys | See chapter 2, section 2.3.5 |
|  | Call main menu | |
|  | Change to left menu | |
|  | Change to right menu | |


19 PORT2

| | | |
|---|--------------------|-------------------------------------|
| PORT 2 | Measurement port 2 | See sections 2.14.1, section 2.15.2 |
|  | | |


20 PORT1

| | | |
|---|--------------------|-------------------------------------|
| PORT 1 | Measurement port 1 | See sections 2.14.1, section 2.15.2 |
|  | | |

21 OUTPUT a1

| | | |
|---|---|-----------------------------|
| OUTPUT a1 | Additional generator output (N-socket) , available with option ZVR-B25, "External measurements" | See section 2.4.1.2, 2.14.1 |
|  | | |

22

| | | |
|---|-------------------|--|
|  | Ground connector. | |
|---|-------------------|--|

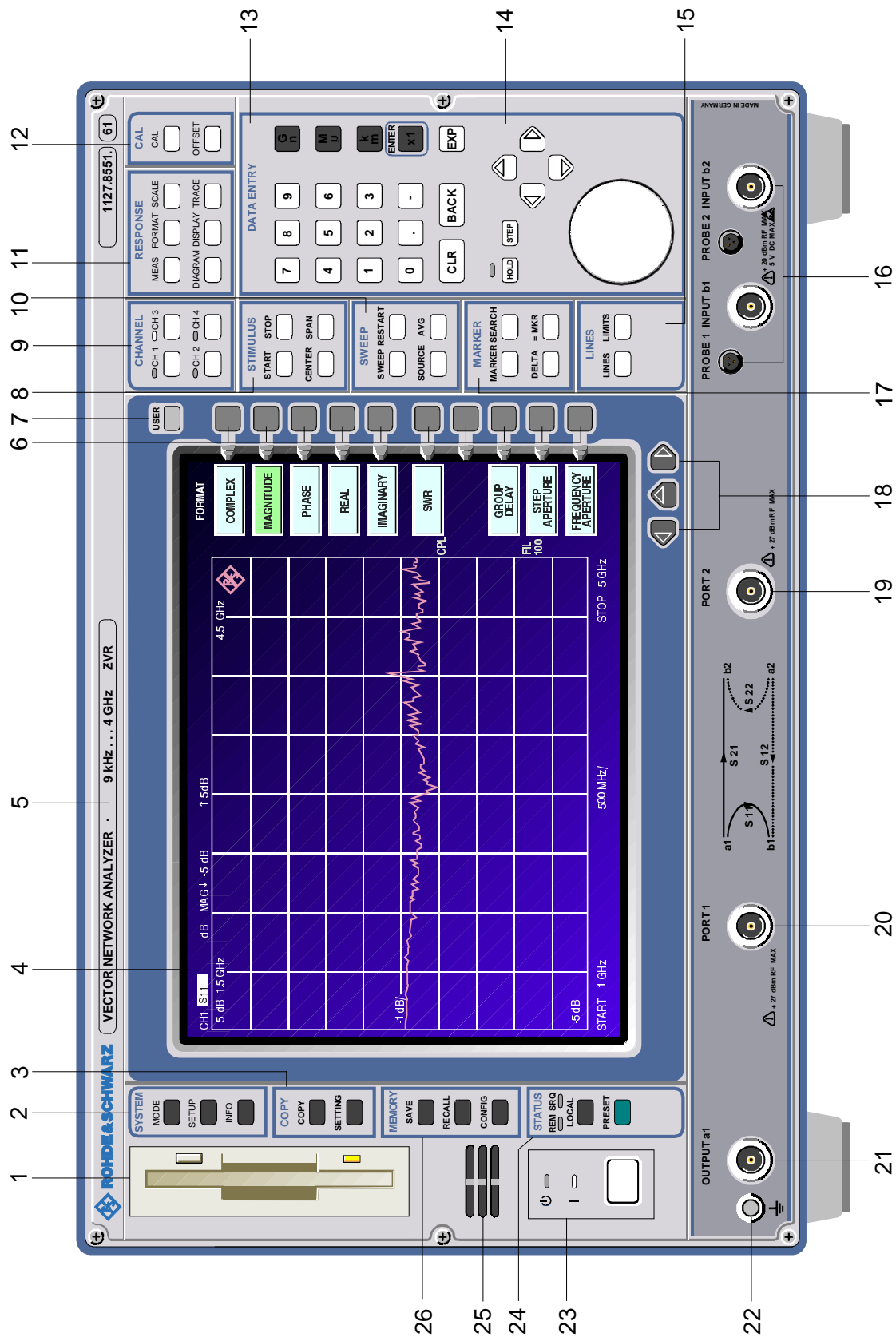
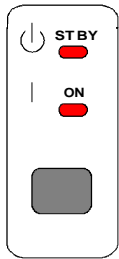


Fig. 1-1 Front view ZVR

23



ON/STANDBY Switch
 LED STBY Indicates that the instrument is in the standby mode



Warning:
In the standby mode the instrument is connected to the AC supply.

LED ON Indicates that the instrument is powered.

See chapter 1, section 1.3.5

24 STATUS



Keys for remote/manual control
 LOCAL Switch from remote to manual control
 The SRQ LED signals that the instrument sends a service request on IEC/IEEE bus. The REM LED signals that the instrument is remote-controlled.
 PRESET Reset default setup

See chapter 2, section 2.7 and chapter 3, section 3.3

25



Internal loudspeaker

26 MEMORY



Storage and loading device settings, data management
 SAVE Store device settings
 RECALL Load device settings
 CONFIG Management of data on floppy and hard disk

See chapter 2, sections 2.2 and 2.6

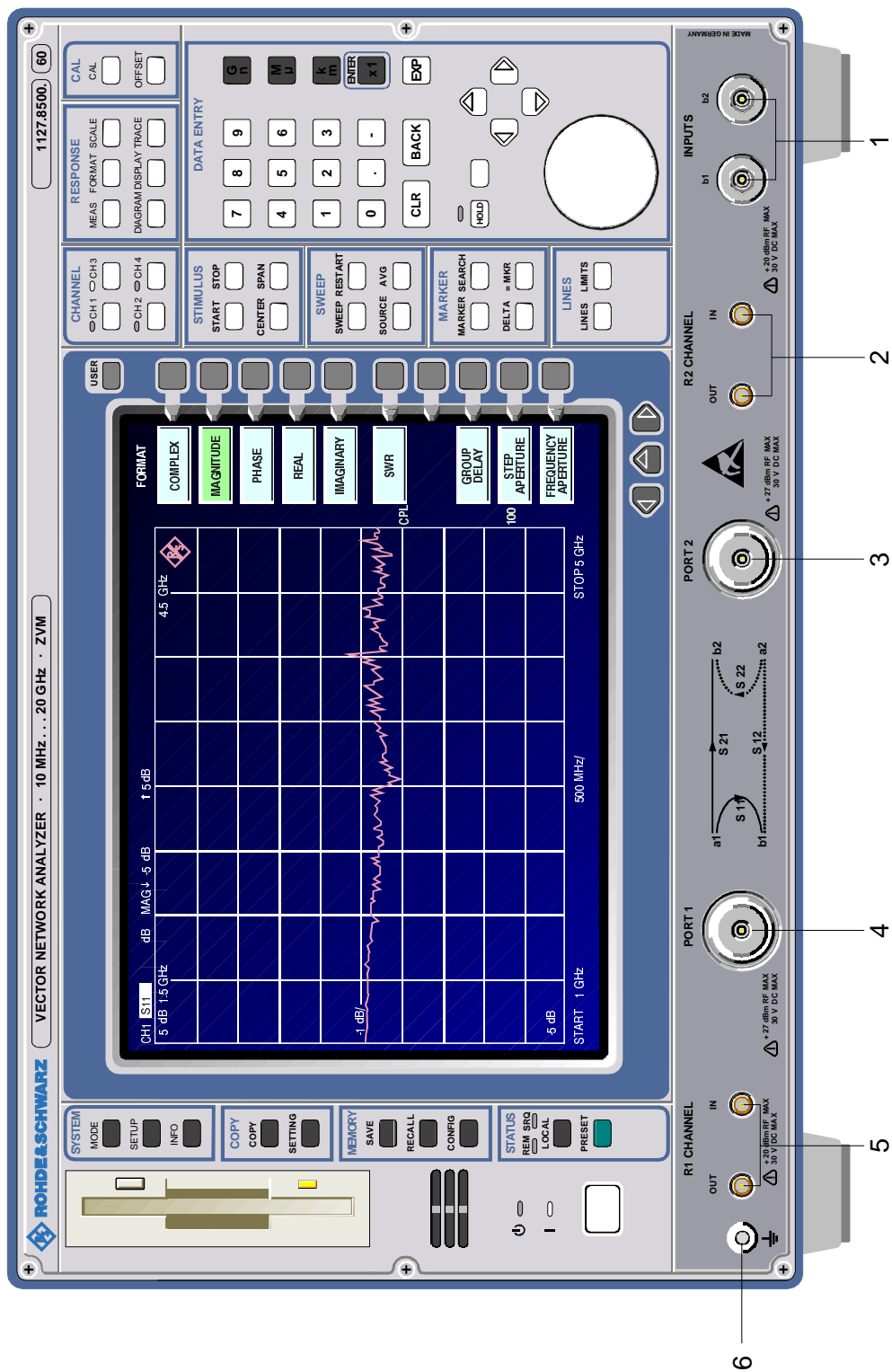


Fig. 1-1 Front view ZVK, ZVM


1.2.1.2 Front View ZVK, ZVM

The control elements correspond to those of ZVR with the exception of the connectors. For this reason, only the connectors of ZVK and ZVM are described.

1 INPUTS

| | | |
|---|---|---|
| <p>b1 b2</p>  | <p>Additional receiver inputs (N-sockets b1 and b2)</p> | <p>See chapter 2.4.1.2 Ext. Measurements and Appendix A</p> |
|---|---|---|

2 R2 CHANNEL

| | | |
|---|--|--|
| <p>OUT IN</p>  | <p>Accessibility to the reference channel of measurement port 2.</p> | |
|---|--|--|


3 PORT 2

| | | |
|---|---------------------------|--|
| <p>PORT 2</p>  | <p>Measurement port 2</p> | <p>See chapter 2.14.1 and 2.15.2</p> |
|---|---------------------------|--|


4 PORT 1

| | | |
|---|---------------------------|--|
| <p>PORT 1</p>  | <p>Measurement port 1</p> | <p>See chapter 2.14.1 and 2.15.2</p> |
|---|---------------------------|--|

5 R1 CHANNEL

| | | |
|---|--|--|
| <p>OUT IN</p>  | <p>Accessibility to the reference channel of measurement port 1.</p> | |
|---|--|--|

6

| | | |
|---|--------------------------|--|
|  | <p>Ground connector.</p> | |
|---|--------------------------|--|

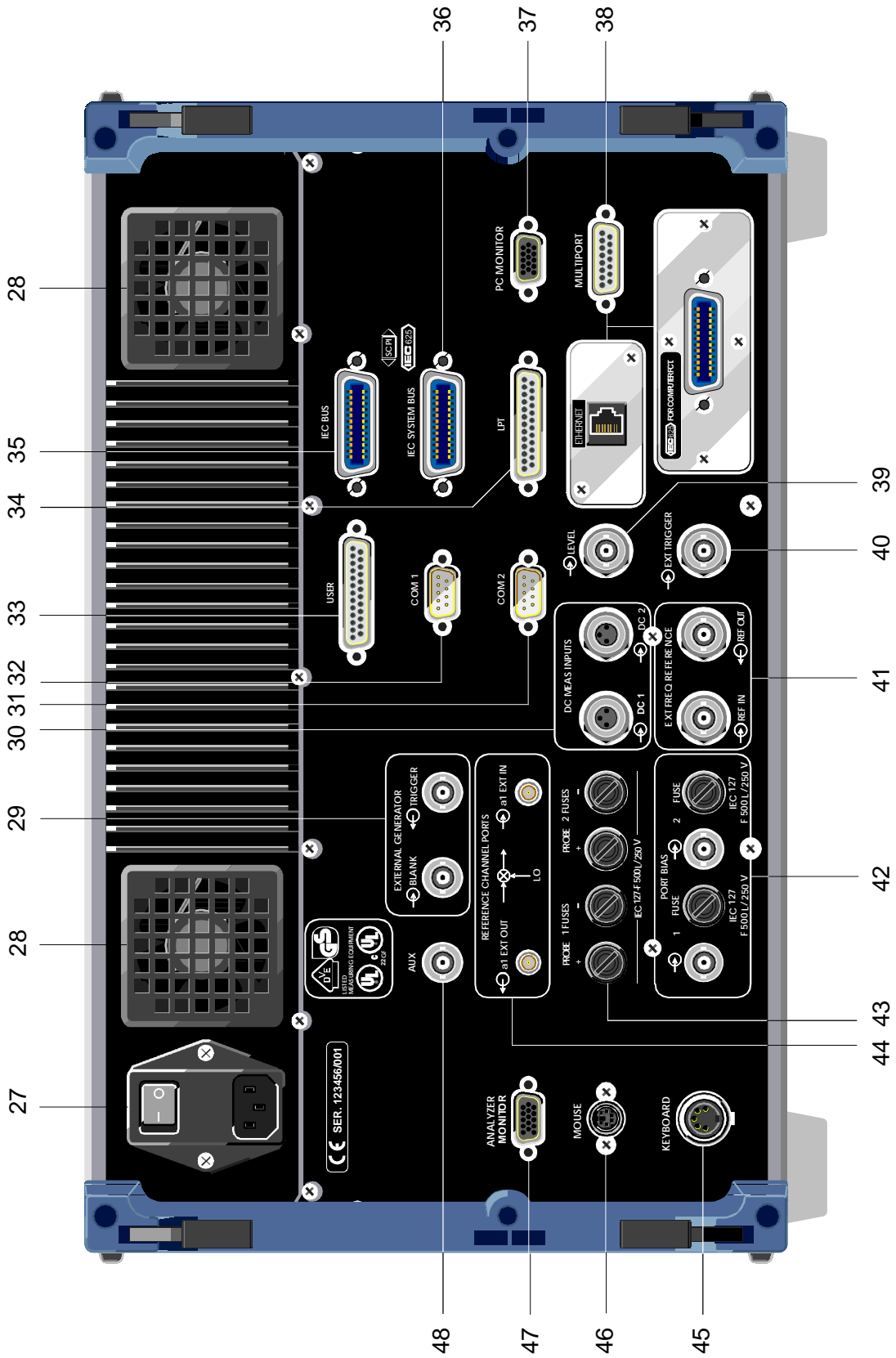
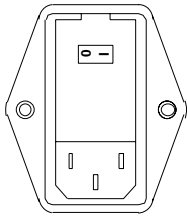


Fig. 1-2 Rear View

1.2.2 Rear View ZVR, ZVK and ZVM

27



Power switch
 Fuse holder
 AC supply connector

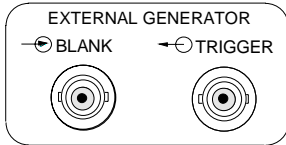
See chapter 1,
 sections 1.3.4
 and 1.3.5

28

Power supply fans

See chapter 1,
 section 1.3.2.1

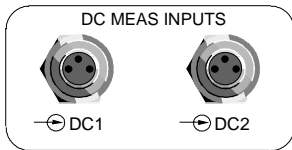
29 EXTERNAL GENERATOR



Connectors for external generator control
 BLANK (input)
 TRIGGER (output)

See Appendix A

30 DC MEAS INPUTS



Inputs for DC-voltage measurement

31 COM2



Serial interface 2
 (9-contact, female; COM2)

See chapter 1,
 section 1.6
 and Appendix A

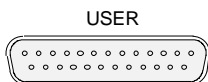
32 COM1



Serial interface 1
 (9-contact, female; COM1)

See chapter 1,
 section 1.6
 and Appendix A

33 USER



User interface with configurable inputs
 and outputs

See Appendix A

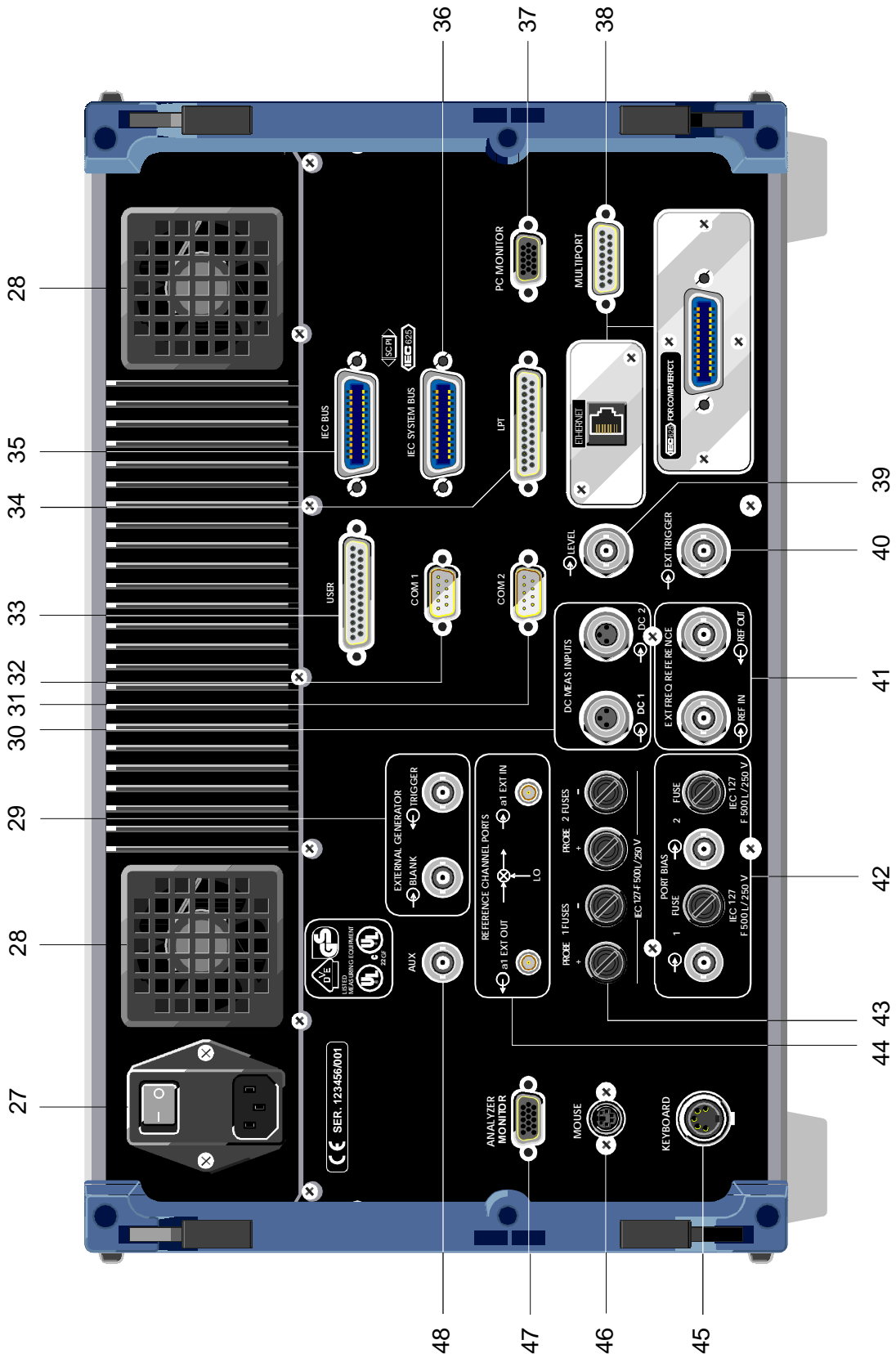
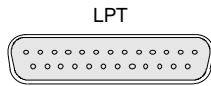


Fig. 1-2 Rear View

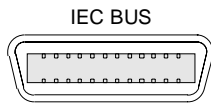
34 LPT



Parallel interface
(printer interface, Centronics-compatible)

See chapter 1,
section 1.6
and Appendix A

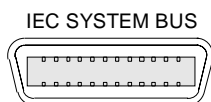
35 IEC1



IEC/IEEE-bus connector 1

See chapter 1,
section 1.6
and Appendix A

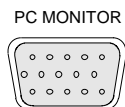
36 IEC2



IEC/IEEE-bus connector 2

See chapter 1,
section 1.6
and Appendix A

37 PC MONITOR



Connector for external VGA monitor

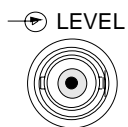
See Appendix A

38

Inputs or outputs for options, e.g. ethernet and multiport
adapter (or cover plates for retrofitting digital interfaces)

See chapter 1.7

39 LEVEL



Input for external level control

See Appendix A

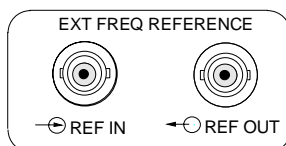
40 EXT TRIGGER



Input for external trigger

See chapter 2,
section 2.10.1.4 and
Appendix A

41 EXT FREQ REFERENCE



REF IN: Input for external
reference (1 to 16 MHz)

REF OUT: 10-MHz output

See chapter 2.4.2.2
and Appendix A

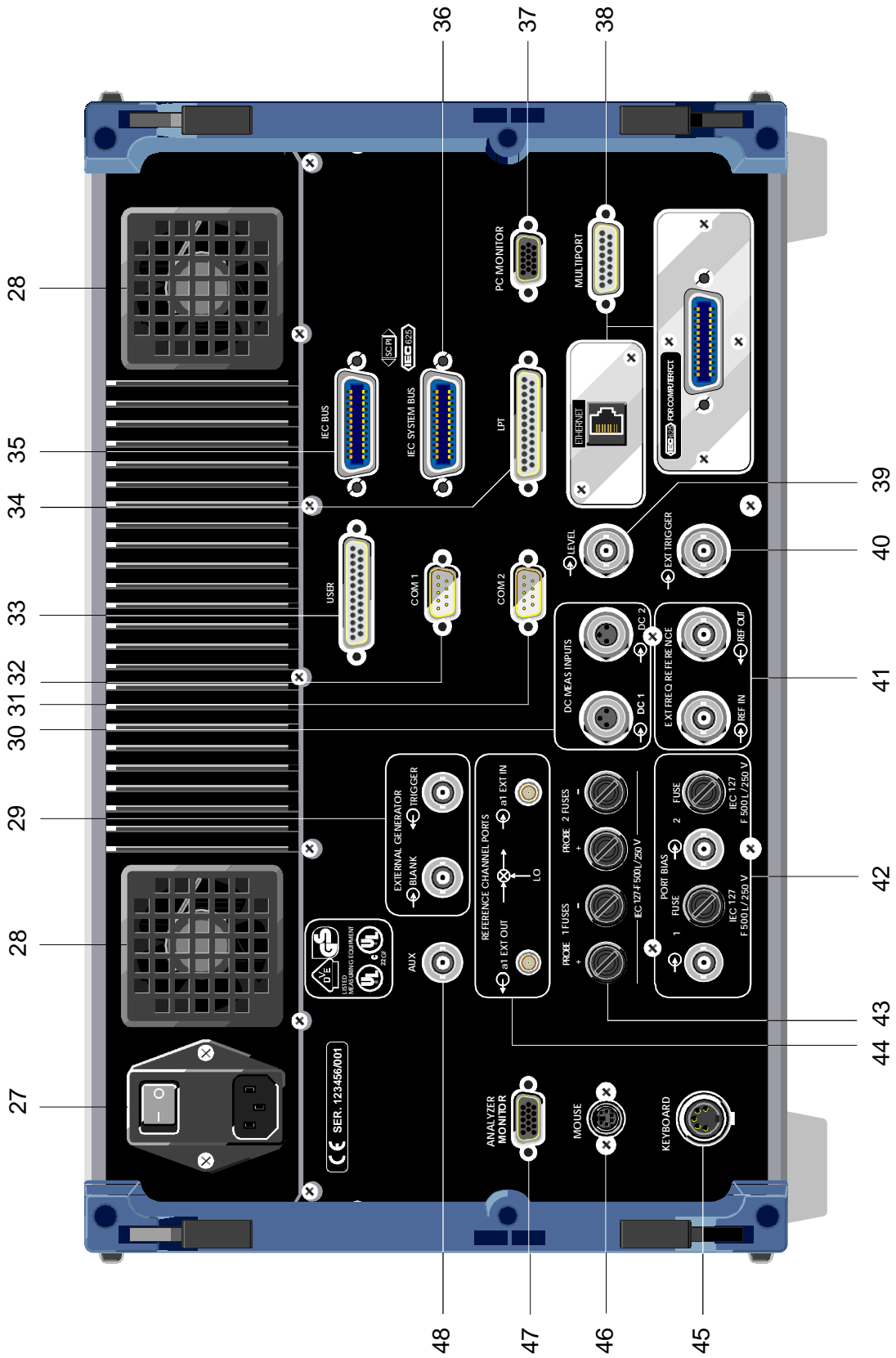
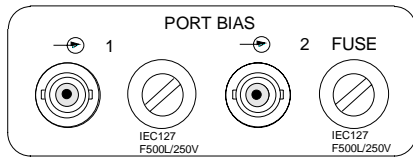


Fig. 1-2 Rear View

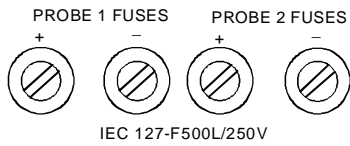
42



Power supply fuses for high-impedance probes 1 and 2 (supply outputs at the front)

See Append. A

43

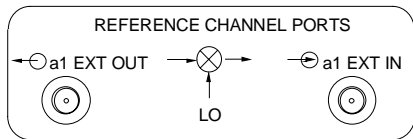


(not for ZVK and ZVM)

DC input for active probes connected to port 1 and 2 and associated fuses (with the use of an active test set)

See Append. A

44 EXTERNAL REF MIXER



Connectors for external mixer

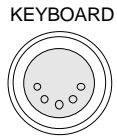
a1 EXT OUT: RF output signal to ext. Ref. mixer

LO: Must be externally provided

a1 EXT IN: IF input signal from ext. Ref. mixer

See chapter 2.4.1.6 and Appendix A

45 KEYBOARD



Connector for external keyboard

See chapter 1, section 1.5 and Appendix A

46 MOUSE



Connector for mouse

See chapter 1, section 1.4 and Appendix A

47 ANALYZER MONITOR



Connector for external monitor

See Append. A

48 AUX



For future extensions

1.3 Start-Up



Important Note:

Before turning the instrument on, it must be observed that the following conditions are fulfilled:

- instrument covers are in place and all fasteners are tightened,
- fan openings are free from obstructions,
- signal levels at the input connectors are all within specified maximums,
- signal outputs are correctly connected and not overloaded.

Non-observance may cause damage to the instrument .

1.3.1 Unpacking the Instrument

After the instrument has been removed from its packaging, please insure that all deliverable items are present as follows:

- Vector network analyzer (ZVR, ZVRE, ZVRL, ZVC, ZVCE, ZVM or ZVK)
- AC power cable, keyboard, mouse
- Operating manual

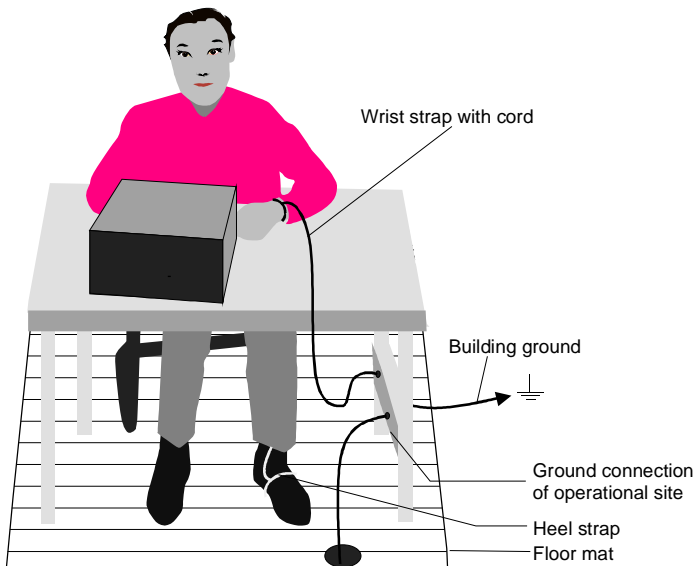
Now check the instrument for visible mechanical damage. If damage is present, promptly inform the delivery firm that delivered the instrument. In case damage is found, retain the carton and the packing materials.

Equipment returned or sent in for repair must be packed in the original packing or in packing with electrostatic protection.

1.3.2 Instrument Setup

1.3.2.1 Stand-alone Operation

The network analyzer is designed for use under general laboratory conditions. The ambient conditions required at the operational site are as follows:



- The ambient temperature must be in the range of + 5 ... + 45 °C.
- All fan openings must be unobstructed and the air flow at the rear panel and at the side-panel perforations must not be obstructed. The distance to the wall should be at least 10 cm.
- The mounting surface should be flat.
- To avoid damage of electronic components of the DUT and the analyzer, the operational site must be protected against electrostatic discharge.

1.3.2.2 19" Rack Installation



Important Note:

For rack installation, insure that the air flow at the side-panel perforations and the air exhaust at the rear panel is not obstructed.

The instrument may be mounted in a 19" rack by using the rack adapter kit ZZA-95 (order number: 396.4911.00). The installation instructions are included in the adapter kit.

1.3.3 EMI Protection Measures

In order to prevent electromagnetic interference (EMI), the instrument may be operated only when all covers are correctly in place. Only adequately shielded signal and control cables may be used (see recommended accessories).

1.3.4 Connecting to AC Power

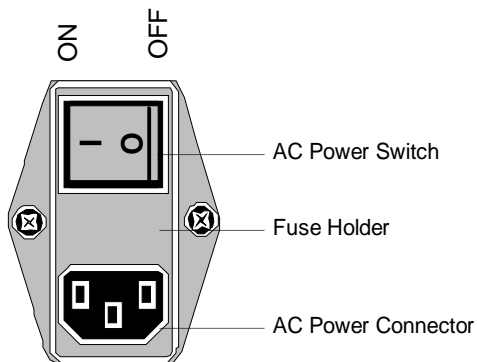
The network analyzer is equipped with an AC voltage selection feature and will automatically set itself according to the applied AC voltage (range: 90 V to 132 V(AC) and 180 V to 265 V(AC), 47 Hz to 440 Hz). The AC power connector is located on the rear panel (see below).

- Connect the network analyzer to the AC power source using the AC power cable delivered with the instrument.

1.3.5 AC Power Line Fuses

The network analyzer is protected by two fuses as specified on the power supply name-plate. The fuses are located in a removable fuse holder which is located between the AC power switch and the AC power connector (see below).

AC power switch on the rear panel



Power On/Off

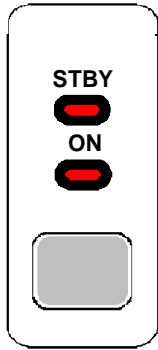
- Depress the AC Power Switch to the desired position ON/OFF.

After turn-on (position ON), the instrument is in the ready state (STANDBY) or in operation dependent upon the position of the ON/STANDBY switch located on the instrument front panel (see below).

Note: The AC power switch may remain ON continuously. Switching to OFF is only required when the instrument must be completely removed from the AC power source.

Switching to OFF (position OFF) removes all instrument circuitry from the AC power source.

ON/STANDBY switch on the front panel



Caution:

In standby mode, the AC power voltage is present within the instrument.

Standby

- ON/STANDBY switch is not depressed.

The yellow LED (STANDBY) is illuminated. The DC power supply is supplied with power.

Operation

- ON/STANDBY is depressed.

The green LED (ON) is illuminated. The instrument is ready for operation. All modules within the instrument are supplied with power.

1.3.6 Battery-Powered Memory

The network analyzer is equipped with a battery-powered read/write memory (CMOS-RAM) where instrument settings are saved at power-off. After each power-on, the network analyzer is reloaded with the operational parameters which were active just prior to the last power-off (STANDBY or AC power OFF).

A lithium battery is used to supply power to the CMOS-RAM. When the battery is depleted (expected life is approx. 5 years), any data stored in CMOS-RAM will be lost. In this case, the factory standard setup is loaded at turn-on. Changing batteries requires opening of the instrument and is described in the service manual.

1.4 Controller Function

**Caution:**

- *The drivers used in the integrated controller function are adapted to the measuring instrument. Only the settings described below should be resorted to. The existing driver software should be modified only with the update software released by Rohde&Schwarz.*
- *Do not power down during booting. Such a switch-off may lead to corruption of the hard disk files.*

The instrument possesses an integrated Windows-NT controller. The user can switch between the measurement screen and the controller screen. When an external monitor is connected, the measurement function and the controller function can be displayed simultaneously (see section "Connecting an External Monitor"). The controller function is automatically booted on instrument power-up.

Windows NT operation is described in the supplied manual or in the online help of Windows NT.

Login

Windows NT requires a login window in which the user is asked to identify himself by entering his name and password. An autologin comes as standard in the instrument, ie the login is performed automatically in the background. The user name used for this is "instrument" and the password is also "instrument" (in small letters).

To login under another name, call up the logout window in the task bar with START - SHUT DOWN. Mark the item "Close all programs and log on as a different user?" in the window and click YES while holding the SHIFT key down until the login window is displayed to enter the user identification. The password should be entered in the correct syntax including low-case and upper-case characters.

Administrator identification

Some of the installations (eg CD-ROM drive) described below are possible only under the administrator login. This is indicated in the relevant window.

The administrator is an identification prescribed by Windows NT which in particular allows system settings which are disabled for the standard user.

The password for the administrator is 894129 for the instrument.

After an installation under the administrator identification, the "Service Pack X" of Windows NT is to be re-installed, see section "Installation of Windows NT Software".

On the power-up following an installation under the administrator identification, the NT login window is displayed (no autologin). The user name "Administrator" is indicated in the window. This entry is to be replaced by "instrument" and then "instrument" as password entered. An autologin is then possible.

Changeover between measurement screen and controller screen

To call up the controller screen use key combination <ALT><SYSREQ> (US keyboard).

To return to the measurement screen, activate the window "Rohde & Schwarz ZVR NT Interface" on the controller.

Logout

The instrument can be switched off (standby mode). Logging out of Windows NT is not necessary.

Additional Software

The following program packages were successfully tested for their compliance with the measuring instruments software:

- ZVR-K9 – software for virtual transformation networks
- FileShredder – for secure deletion of files from hard disk
- Symantec Norton AntiVirus – virus protection software

1.5 Connecting a Mouse

**Caution:**

The mouse may only be connected when the instrument is switched off (STANDBY). Otherwise, correct operation of the mouse and instrument cannot be guaranteed.

The instrument has the facility to simplify operation by connecting a mouse to the rear-panel PS/2-mouse connector (MOUSE) for .

MOUSE



During measurement operation, softkeys, tables and data input fields may also be controlled via the mouse. For computer function, the mouse has the usual functions.

The control functions for the mouse during measurement operation are described in Chapter 2 in the section "Mouse Operations". Appendix E contains a list in which the screen display elements for mouse control of the corresponding soft keys and push buttons of the instrument are described. Appendix A contains the interface description.

After connection the mouse is automatically recognized. Special settings such as mouse cursor speed etc., can be performed in the Windows NT menu START - SETTINGS - CONTROL PANEL - MOUSE.

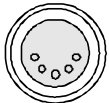
1.6 Connecting an External Keyboard

**Caution:**

The keyboard may only be connected when the instrument is switched off (STANDBY). Otherwise, correct operation of the keyboard cannot be guaranteed.

The instrument is fitted with a rear-panel 5-contact DIN connector (KEYBOARD) for the connection of an external PC keyboard.

KEYBOARD



During measurement operations, the keyboard simplifies the input of commentary text, filenames, etc. For computer function, the keyboard has the usual functions.

Appendix E contains a list which describes the assignment of the instrument front-panel key functions to the key codes of the external keyboard as well as special key combinations used for quick operations. Appendix A contains the interface description.

After connection the keyboard is automatically recognized. The default setting is for the US keyboard. Special settings such as repetitional rate etc. can be performed in Windows NT menu START - SETTINGS - CONTROL PANEL - KEYBOARD.

1.7 Connecting an External Monitor



Caution:

The monitor may only be connected when the instrument is switched off (STANDBY). Otherwise, the monitor may be damaged.

Do not modify the screen driver (display type) since this would disturb instrument operation.

- Notes:**
- When connecting the monitor to the PC MONITOR connector, the display of controller function can be adapted to the external screen (eg higher resolution) in the NT menu START-SETTING - CONTROL PANEL - DISPLAY PROPERTIES.
 - CHIPS (setting = both) should not be modified since otherwise switching between the external monitor and the instrument screen is not possible.

The instrument is fitted with a rear-panel connector PC MONITOR or ANALYZER MONITOR for the connection of an external monitor.



With an external monitor it is possible to have an enlarged display of the measurement screen (ANALYZER MONITOR connector) or of the controller screen (PC MONITOR connector). The measuring instrument and the Windows NT controller can be operated in parallel. The mouse and the keyboard are allocated to only one mode.

Display of the measurement screen - Connection to ANALYZER MONITOR connector

Connection

After connecting the external monitor the measurement screen is displayed on both the external monitor and the instrument. Further settings are not necessary.

Operation

The instrument is operated as usual via its softkeys, the mouse and keyboard, etc..

Toggle between measurement screen and controller screen

Key combination <ALT><SYSREQ> is used to call up the controller. After call up, the mouse and keyboard are allocated to the controller function.

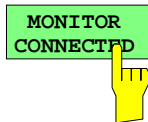
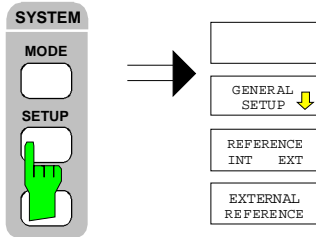
By activating the window " Rohde & Schwarz ZVR NT Interface " the user returns to the measurement screen and the mouse and keyboard are allocated to this screen.

Display of the controller screen - Connection to PC MONITOR connector

Connection

After connecting the monitor external monitor operation should be selected.

Setting is performed in the *SYSTEM SETUP-GENERAL SETUP* menu (key group: *SYSTEM*, see in Chapter 2, the section "Presettings and Interface Configuration"):



Call *SETUP-GENERAL SETUP* menu

- Press the *SETUP* key in the *SYSTEM* field.

The *SETUP* menu is opened.

-
- Press the *GENERAL SETUP* softkey.

The *GENERAL SETUP* submenu is opened and the current settings of the instrument parameters are displayed on the screen in the form of tables.

Selecting the external monitor mode

- Press the *MONITOR CONNECTED* softkey.

The softkey is in color to indicate that the external monitor mode is activated. The external monitor displays the controller screen.

Operation

The controller function is operated as usual with the mouse and keyboard. The measuring instrument (displayed on the instrument screen) can be operated with both the softkeys and keys of the instrument.

Toggle between screens

By activating (clicking) the window "R&S Analyzer Interface" at the controller the mouse and keyboard are allocated to the measurement screen. The mouse and keyboard are allocated to the controller when the window is deactivated.

1.8 Connecting an Output Device



Caution:

The output device may be connected only when the instrument is switched off (STANDBY)

- Note:**
- The installation of some printer drivers is possible only under the administrator identification (see section "Controller Function").
 - After the installation, the "Service Pack X" of Windows NT is to be re-installed, see "New Installation of Windows NT Software".
 - To ensure that the instrument performs an autologin, the user identification is to be reset to "instrument" after the next power-up, see section "Controller Function".

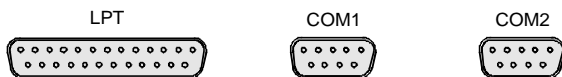
The instrument provides an option for connecting up to three different output devices to allow printing a hard copy of the display screen.

The interfaces can also be used for printing in the controller mode. The output formats "WMF" (Windows Metafile) and "Clipboard" are preset. A large number of output devices can be connected under Windows NT after installing suitable printer drivers.

The output devices supported by the instrument can be found in the selection box *DEVICE/LANGUAGE* in the *COPY -SETTINGS DEVICE1/2* menu (see in Chapter 2, the section "Documentation of Measurement Results"). To print out via the COM interface, the latter must be assigned the controller function in the *SETUP - GENERAL SETUP* menu (owner = OS).

Appendix A contains the interface description of the connectors.

The interface connectors are located on the rear panel:



After connection of the output device to the appropriate interface connector, the configuration of the interface as well as the output device must be entered and the output device must be assigned to the interface.

1. Configuration of the interface

LPT1 Interface LPT1 cannot be configured.

Note: An external CM-ROM drive can be connected to this interface. If this interface is allocated, one of the serial interfaces can be used for the printout.

COM1/COM2 The configuration of serial interfaces COM1 and COM2 can be performed in the Windows NT menu *START - SETTINGS - CONTROL PANEL - PORTS*. The parameters *COM PORTS BAUDRATE, BITS, PARITY, STOPBITS, HW/SW-HANDSHAKE* determine the transmission parameters of the interface. They must agree with the specifications of the output device (see the operating manual for the output device). To print out via the COM interface, the latter must first be assigned the controller function in the *SETUP - GENERAL SETUP* menu (owner = OS).

Note: Allocation of the instrument (Owner = Instrument) in the menu *SETUP - GENERAL SETUP* makes the interfaces available for remote control. The settings made in the menu *SETUP - GENERAL SETUP* overwrite the settings in the NT menu.

However, settings in the Windows NT menu do not overwrite those of the *SETUP* menu. This means that the settings are only valid as long as the interfaces are allocated to the controller.

2. Selection and installation of the printer driver

The selection and installation of the printer driver, the assignment to the interface and the setting of most of the printer-specific parameters (eg paper size) is performed under Windows NT in the START - SETTINGS - PRINTER menu.

3. Configuration of the connected output device

The configuration of the connected output device and the assignment to the interface takes place in the *HARDCOPY DEVICE-SETTINGS DEVICE1/2* menu (key group: *COPY*, see in Chapter 2, the section "Selection and Configuration of the Output Device "). The configuration of up to two output devices (*DEVICE1* and *DEVICE2*) may be entered, of which, at least one must be activated for printing.

- The parameter *DEVICE/LANGUAGE* determines which output device is to be used.
- The parameter *PRINT TO FILE* determines if the output is in the form of a file.
- The parameter *ORIENTATION* sets the page format to horizontal or vertical (portrait).

Selecting the type of printer automatically sets the parameters *PRINT TO FILE* and *ORIENTATION* to values which correspond to a standard mode with this output device. Other printer-dependent parameters such as *FORMFEED*, *PAPERFEED* etc., can be modified under Windows NT in the printer properties window (START/SETTINGS/PRINTER/SETTINGS/....).

Table 1-1 shows the standard factory settings for the two output devices.

The factory settings of *DEVICE 1* correspond to output format "WMF" (Windows Metafile), printing is performed in a file. WMF is a common format which is used for the import of hardcopies (eg measurement windows) to other Windows applications that support this format (eg WinWord).

The factory setting of *DEVICE 2* is "Clipboard". In this setting the printout is copied to the Windows NT clipboard. Most of Windows applications support the clipboard. The clipboard content can be directly inserted in a document via EDIT - PASTE.

Table 1-1 Factory settings for *DEVICE 1* and *DEVICE 2* in the *HARDCOPY-DEVICE SETTINGS* menu.

| Parameter | Parameter Name | <i>DEVICE 1 Settings</i> | <i>DEVICE 2 Settings</i> |
|---------------|-----------------|--------------------------|--------------------------|
| Output Device | DEVICE/LANGUAGE | WINDOWS METAFILE | CLIPBOARD |
| Output | PRINT TO FILE | YES | --- |
| Paper Format | ORIENTATION | --- | --- |

In the following example, a HP DeskJet 660C printer is connected to interface LPT1 and configured as *DEVICE2* of the instrument to output hardcopies of the measurement screen.

Switch off device.

Connect printer to interface LPT1.

Switch on device.

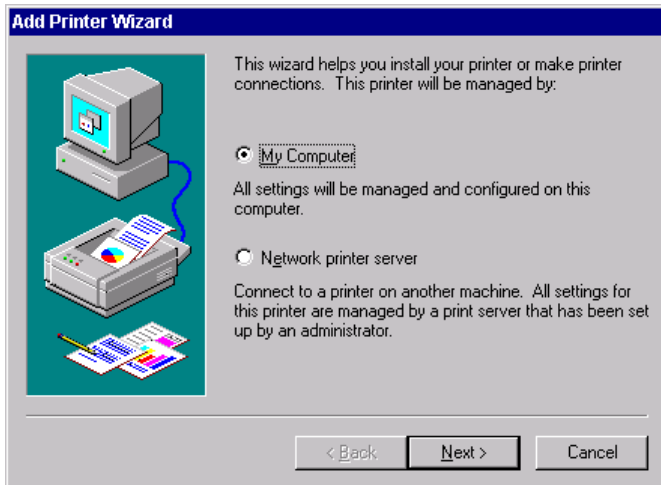
Select printer driver under Windows NT

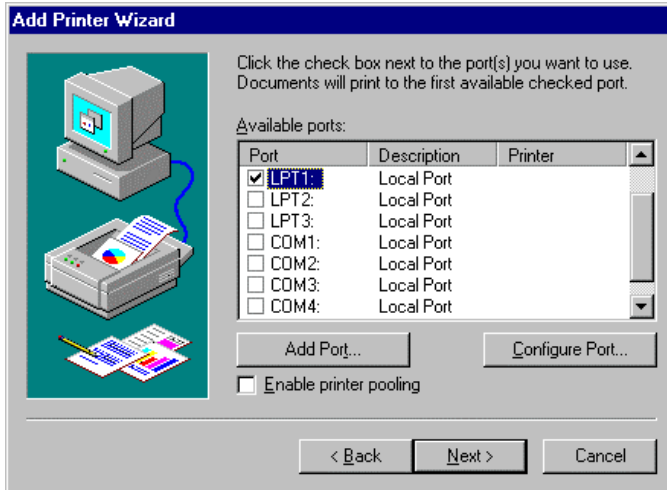
- Press key combination <ALT> <SYSREQ>
The Windows NT screen is displayed.

- In the Start menu press first "Setting" and then "Printers".
The printer window is opened.

- Double-click symbol "Add Printer".
The "Add Printer Wizard" window is opened. This window leads through the following printer driver installation.

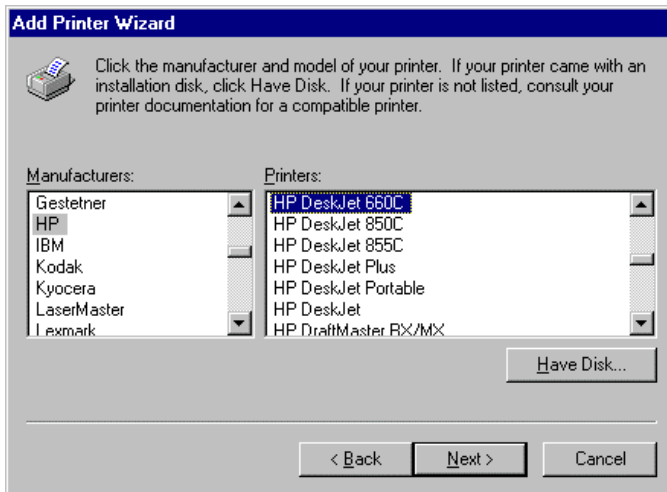
- Click first "My computer" and then "Next".
The available ports are displayed.





- Select LPT1 port.
The selection is marked by a tick.

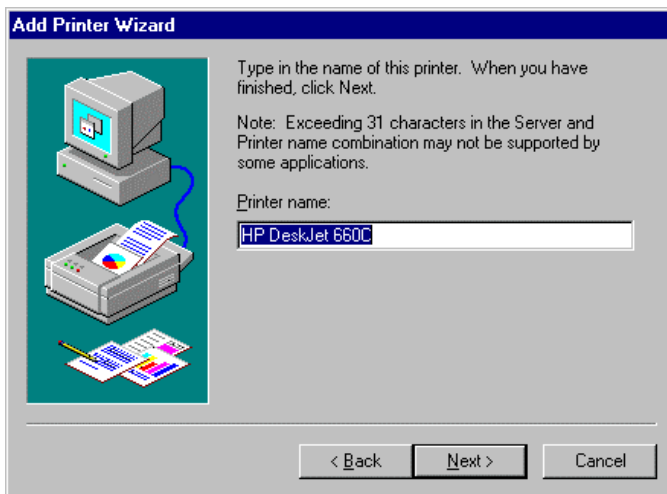
- Click "Next".
The available printer drivers are displayed. The left-hand selection table indicates the manufacturers and the right-hand one the available printer drivers.



- Mark "HP" in selection table "Manufacturers" and "HP DeskJet 660C" in selection table "Printers".

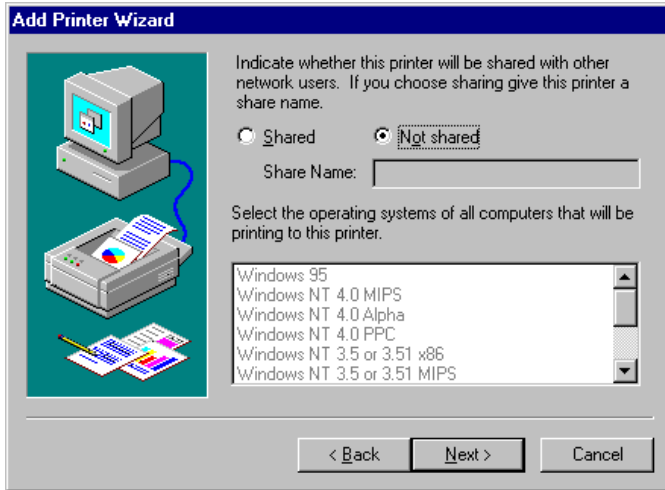
Note: *If the desired type of output device is not shown in this list, it means that it is not supported by Windows NT.*

- Click "Next".
The entry field for the printer name is displayed.



- The printer name can be modified in the entry field "Printer name" (max. 60 characters).

If one or more printers are already installed, a query is displayed in this window to ask if the printer last installed as default printer should be selected for the Windows NT applications (Do you want your Windows-based programs to use this printer as default printer?) "No" is preset.



- Click "Next".

A query is displayed for providing the printer in the network. This query is irrelevant when installing a local printer. The answer "Not shared" is preset.

- Click "Next".

The window for starting a test page is displayed. The test page is for checking if the installation was successful.



- Switch on printer.
- Click Yes (recommended)".
- Click "Finish".

A test page is printed out if the installation was successful.

If the test page is not printed out or not completely, the Windows NT online help offers troubleshooting instructions under the entry "Printer Trouble Shooting".

Note:

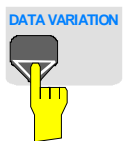
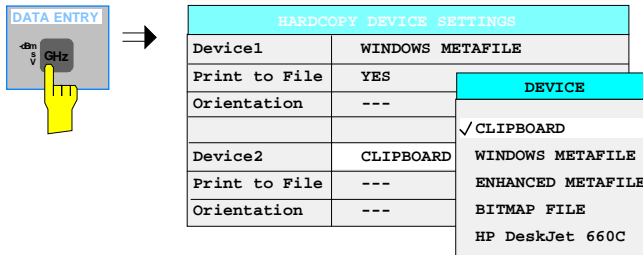
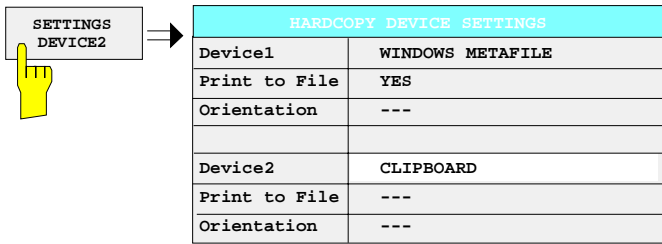
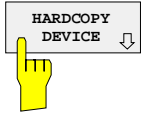
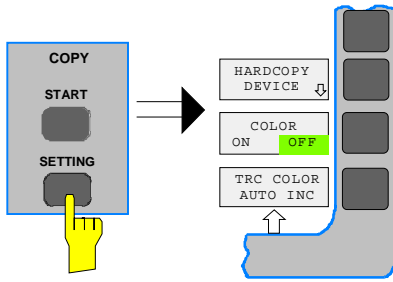
If after clicking "Finish" the user is asked to specify the path for the printer driver, this printer installation should be performed under the administrator identification (see section "Controller Function").

The instrument has to be configured with this printer for the printout of the measurement screen.

Configuring HP DeskJet 660C.

- Click button "Rohde & Schwarz ZVR NT Interface".

The measurement screen is displayed.



- Press the *SETTINGS* key in the *COPY* field.

The *SETTING* menu is opened.

- Press the *HARDCOPY DEVICE* softkey.

The *HARDCOPY DEVICE* submenu is opened and the current settings of the two possible output devices are displayed on the screen in the form of tables.

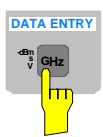
- Press *SETTING DEVICE2*.

Line *DEVICE2* is marked with the selection bar.

- Press one of the unit keys.

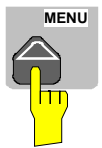
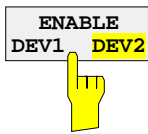
The selection box *DEVICE* is displayed on the screen. The current selection is marked by a tick and highlighted by the selection bar.

- Press cursor key until the entry *HP DeskJet 600C* is highlighted by the selection bar.



⇒

| HARDCOPY DEVICE SETTINGS | |
|--------------------------|------------------|
| Device1 | WINDOWS METAFILE |
| Print to File | YES |
| Orientation | --- |
| Device2 | HP Deskjet 660C |
| Print to File | NO |
| Orientation | PORTRAIT |



- Press one of the unit keys.

The selection box *DEVICE* is closed and *HP DeskJet 660C* is entered in line *DEVICE2*.

Note:

Selecting the type of printer automatically sets the parameters *PRINT TO FILE* and *ORIENTATION* to values which correspond to a standard mode with this output device. Other printer-dependent parameters such as *PAPERSIZE*, can be modified under *Windows NT* in the printer properties window (*START/SETTINGS/PRINTER/SETTINGS*).

Switch on printer.

- Press *ENABLE* softkey until *DEV2* is marked on the second softkey line.

Printing can then be started with the *START* key in the *HARDCOPY* menu.

Return to main menu

- Press the menu key several times.

Note: After the installation, the "Service Pack X" of *Windows NT* is to be re-installed, see "New Installation of *Windows NT* Software".

1.9 Connecting a CD-ROM Drive



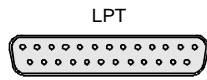
Caution:

The CD-ROM may only be connected when the instrument is switched off (STANDBY). If this is not observed correct operation of the CD-ROM and the instrument cannot be guaranteed.

Notes: The installation of a CD-ROM is possible only under the administrator identification (see section "Controller Function").

- After the installation, the "Service Pack X" of Windows NT is to be re-installed, see "New Installation of Windows NT Software".
- To ensure that the instrument performs an autologin, the user identification is to be reset to "instrument" after the next power-up, see section "Controller Function",

The instrument is fitted with a rear-panel interface LPT1 for the connection of a CD-ROM drive.



The following CD-ROM drives are supported:

- MICROSOLUTIONS BACKPACK External CD-ROM.
- FREECOM IQ DRIVE
- ADAPTEC Parallel SCSI Adapter + SCSI CD-ROM

After connection, the CD-ROM drive is to be installed under Windows NT.

Switch off device.

Connect CD-ROM drive to interface LPT1 of the instrument and to AC power source.

Switch on device.

Administrator identification

- Press key combination <ALT> <SYSREQ>

The Windows NT screen is displayed.

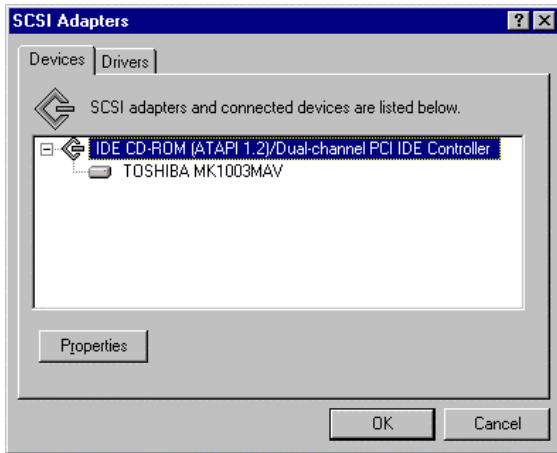
-
- Call the logout window with "Shut Down" in the "Start" menu.

- Mark entry "Shut down and log on as a different user".

- Press Shift key and click button "Yes" at the same time.

The login window is displayed.

- Enter "administrator" under "name" and "894129" under "password", confirm entry with "OK".



Select driver under Windows NT

- In the Start menu press first "Setting" and then "Control Panel".

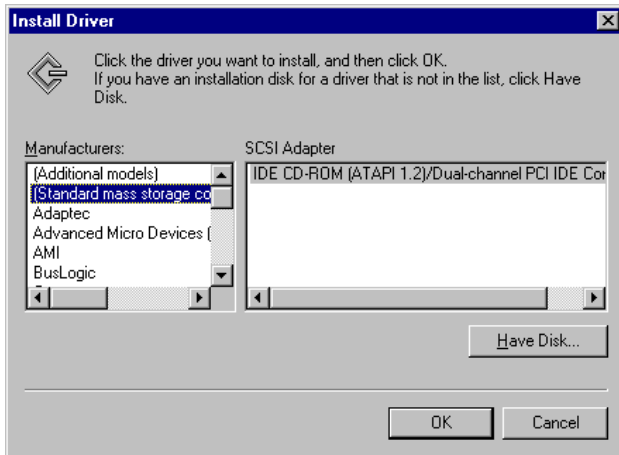
The system control window is opened.

- Double-click symbol "SCSI Adapters".

The "SCSI Adapters" window is opened.

- Click "Driver" index card and then button "Add".

The list of installed drivers is displayed.



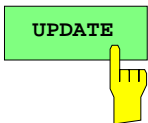
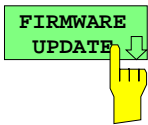
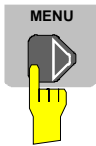
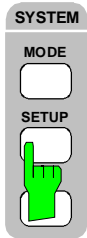
- Click "Have Disk".

This window leads through the following installation.

Note: After the installation, the "Service Pack X" of Windows NT is to be re-installed, see "New Installation of Windows NT Software".

1.10 Firmware Update

The installation of a new firmware version can be performed using the built-in diskette drive and does not require opening the spectrum analyzer. The firmware update kit contains several diskettes. The installation program is called up in the *SYSTEM - SETUP* menu.



The installation can be cancelled.



Insert diskette 1 into the drive.

Call *SETUP-GENERAL SETUP* menu

- Press the *SETUP* key in the *SYSTEM* field.
The *SETUP* menu is opened.

-
- Change to the right-hand menu using the menu key.

-
- Press the *FIRMWARE UPDATE* softkey.
The submenu is opened.

-
- Press the *UPDATE* softkey.
The installation program starts and leads the user through the remaining steps of the update.

-
- Press the *RESTORE* softkey.
The previous firmware version is restored.

1.11 Installing Windows NT Software

The driver software and the system settings of Windows NT are exactly adapted to the measurement functions of the instrument. Correct operation of the instrument can therefore be guaranteed only if the software and hardware used is released or offered by Rohde & Schwarz.

The use of other software or hardware may cause malfunctioning or failures in the functions of the instrument.

A current list of released software can be obtained from your nearest Rohde&Schwarz agency (see list of addresses).

After each software installation requiring the administrator identification, it is necessary to re-install the "Service Pack X" of Windows NT (also with administrator identification; see section "Controller Function"):

Re-installing Service Pack X

- In the Start menu press first "Setting" and then "Run".

The entry window is opened.

-
- Enter "C:\SPX\I386\UPDATE" into the command line and start installation with "OK".

The following window leads through the installation.

1.12 Options

1.12.1 Option FSE-B17 – Third IEC/IEEE Interface

- Notes:**
- The installation of option FSE-B17 is possible only under the administrator identification (see section "Controller Function").
 - After the installation, the "Service Pack X" of Windows NT is to be re-installed, see "New Installation of Windows NT Software".
 - To ensure that the instrument performs an autologin, the user identification is to be reset to "instrument" after the next power-up, see section "Controller Function".

Besides the instrument external devices can also be controlled via the IEC/IEEE bus using the optional 3rd bus interface FSE-B17 and the computer function for instrument. The interface software permits IEC/IEEE-bus commands to be included in user programs. The installation instructions are enclosed with the option.

1.12.1.1 Installing the software

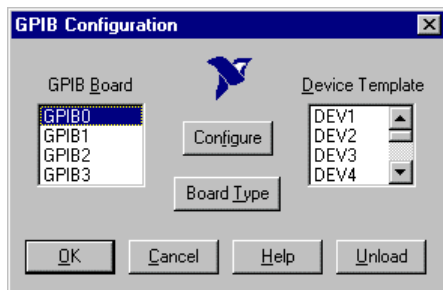
The operating software is already installed and need not be loaded from the driver diskettes which serve as backup diskettes.

The driver must be loaded on the start-up of Windows NT. To do this, enter the type of board, configure the board and enter the parameters for the connected equipment. If the option is factory fitted, all this has been done in the factory.

The following parameters may not be changed after selection on configuration of the board:

```
Board Type .....AT-GPIB/TNT
Base I/O Address .....02C0h
Interrupt Level .....3
DMA Channel .....5
Enable Auto Serial Polling ....No
```

For further parameters, refer to manual for the board.



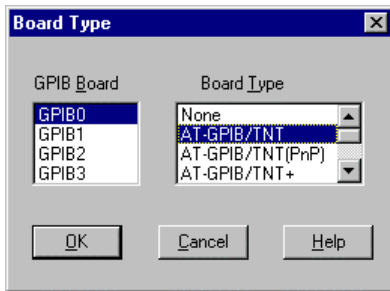
Selecting the board type

- Click "Start" in the task bar.
- Click consecutively "Settings", "Control Panel" and "GPIB" in this sequence.

The "GPIB Configuration" menu for selecting the board type and configuring the board is opened.

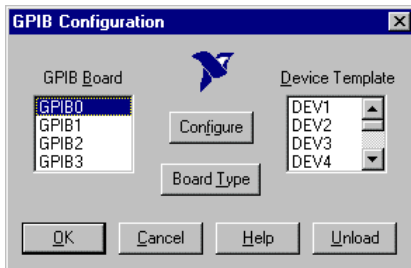
- Click button "Board Type".

The "Board Type" menu for selecting the board type is opened.



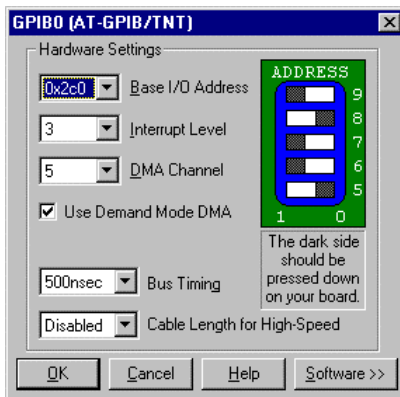
- Mark "GPIB0" in the "GPIB Board" list.
- Mark "AT-GPIB/TNT" in the "Board Type" list.
- Confirm the selection with "OK".

The "GPIB Configuration" menu is displayed again.



- Click button "Configure".

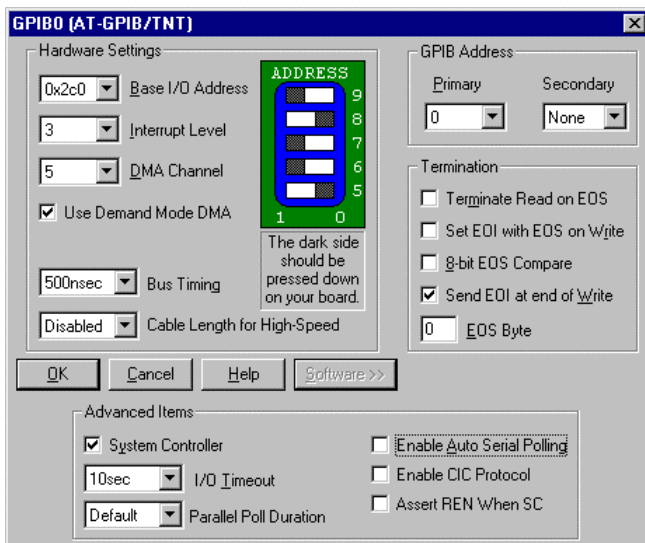
The "GPIB0 (AT-GPIB/TNT)" menu for configuring the board is opened.



Configuring the board

- Set "3" in the "Interrupt Level" list.
- Click button "Software".

The menu is extended.



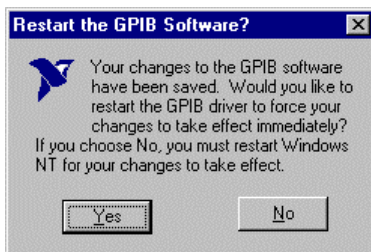
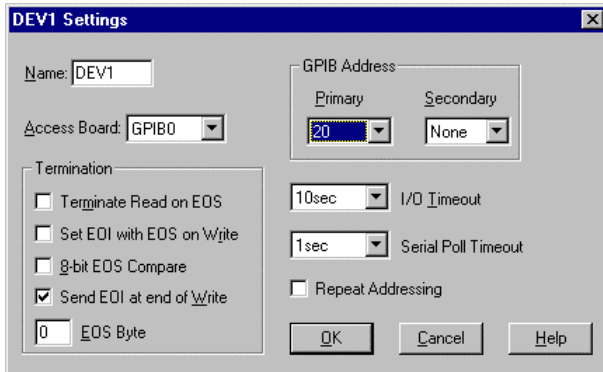
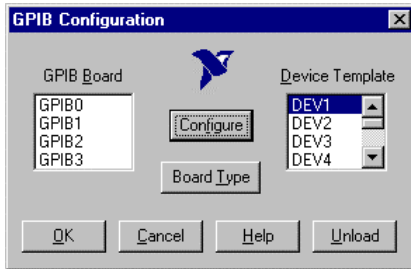
- Deactivate (= no tick) "Enable Auto Serial Polling" in the "Advanced Items" field.
- Quit the menu with "OK".

The "GPIB Configuration" menu is displayed again.

Note:

The settings of the following parameters should not be no longer modified.

```
Board Type           .. AT-GPIB/TNT
Base I/O Address     .. 02C0h
Interrupt Level      .. 3
DMA Channel          .. 5
Enable Auto Serial Polling .. No
```



Setting the parameters for the connected equipment

- Mark the instrument in the "Device Template" list and confirm selection with "OK".

The "DEV.. Settings" menu is opened.

- Perform the settings for the selected unit in the "DEV.. Settings" menu.

The logic name for the instrument is preset with DEV1 and address 20. See board manual for further units.

Note: *when assigning logic names to connected equipment note that these names do not correspond to the directory names under DOS.*

- Terminate setting with "OK".

The query asking if the GPIB software should be re-started is displayed.

- Select "No".

- Re-start controller with Start-Restart in the task bar.

After the controller has been re-started, the settings for the GPIB interface are effective.

Note: *After the installation, the "Service Pack X" of Windows NT is to be re-installed, see "New Installation of Windows NT Software".*

Use of DOS Programs

When using DOS programs, driver GPIB-NT.COM should be loaded. For this to take place, the line `device=C:\PROGRA~1\NATION~1\GPIB\NI488\DosWin16\Gpib-nt.com` has to be activated in the file `C:\WINNT\SYSTEM32\CONFIG.NT`. If the option is factory fitted, this line will have been entered in the factory.

1.12.1.2 Operation

The second IEC/IEEE-bus interface corresponds physically to that of the instrument (see appendix A). If the instrument is to be controlled via the IEC/IEEE bus, a bus cable must be plugged to both bus connectors.

The interface can be driven under DOS/WINDOWS3.1/95/NT by user-written software. The handling of IEC/IEEE-bus commands in user programs is described in the manual for the card.

The files are in directory C:\Program Files\National Instrument\GPIB\NI488.

1.12.2 Option FSE-B16 – Ethernet Adapter

With the option Ethernet Adapter FSE-B16, the device can be connected to an Ethernet-LAN (local area network). It is possible to transmit data via the network and to use the network printer. The adapter operates with a 10 MHz Ethernet in line with standards IEEE 802.3 10Base2 (Thin Ethernet, CheaperNet, BNC-Net) (B16 model 03) or 10Base5 (Thick Ethernet) (B16 model 02).

1.12.2.1 Hardware Installation



Caution:

Prior to installation contact the network administrator, especially in case of complex LAN installations since mistakes in cabling might have influence the whole network.

If the adapter is installed at the factory, it is preconfigured. In case of retrofitting, refer to the installation instructions. The hardware settings must not be modified since the functions of the device could otherwise be impaired.

The following parameters are factory-set:

I/O Addr. 300, IRQ 5, MEM D0000

The connection with the network depends on the connectors used in the network.

BNC (Thin Ethernet, CheaperNet; FSE-B16 Var. 03)

Connection

The device is looped into the LAN segment via rear-panel 2 BNC connectors.

If a cable is not connected to one of the BNC connectors, this BNC connector has to be terminated with 50 Ohm. BNC T connectors must not be used.

Network traffic



Note that the network traffic is disturbed if a segment is interrupted.

Requirements

Thin Ethernet segment requirements have to be complied with:

- maximum segment length of 185 m
- minimum distance between the connectors of 0.5 m
- maximum of 30 connectors per segment.

If components that comply with enhanced requirements are exclusively used (Ethernet Adapter FSE-B16 complies with the enhanced requirements):

- maximum length of segment of 300 m
- maximum number of connectors of 100

With repeaters used:

- maximum total length of the network of 900 m containing a
- maximum of 3 segments
- maximum of two repeaters between two connectors

AUI (Thick Ethernet; FSE-B16 Var. 02)

| | |
|------------------------|---|
| Connection | The device is connected to the LAN segment using a transceiver cable (DB-15 AUI connector, not part of the equipment supplied) which is connected to the rear panel and to the transceiver. |
| Network traffic | The connection does not conflict with the network traffic. The device can also be disconnected from the network without any problems but make sure that data are not being transmitted. |
| Requirements | <p>The Thick Ethernet segment requirements have to be taken into account.</p> <ul style="list-style-type: none"> - The maximum segment length should be 500 m and the distance between the connectors should at least be 2.5 m. - A maximum of 100 connectors may be used in a segment. <p>With repeaters used,</p> <ul style="list-style-type: none"> - the total length of the network must not be more than 2500 m containing - a maximum of 3 segments. - There should be no more than two repeaters between two connectors. <p>If other network components are used, these conditions may vary.</p> |

RJ45 (UTP, 10BaseT, Western Connector; FSE-B16 Var. 04)

| | |
|------------------------|--|
| Connection | The device is connected to the LAN segment using a RJ45 cable (not part of the equipment supplied) which is connected to the rear panel and to the network hub of the LAN segment. |
| Network traffic | This connection does not conflict with the network traffic. The device can also be disconnected from the network without any problems but make sure that data are not being transmitted. |
| Requirements | <p>Since RJ45 is not a bus but a star topology no special requirements have to be taken into account for the connection.</p> <p>The LAN requirements should be considered in the installation.</p> |

1.12.2.2 Software Installation

Data transmission within the network is by means of data blocks, the so-called packets. Besides user data other information, the so-called protocol data (transmitter, receiver, type of data, order) are transmitted. The drivers corresponding to the protocol have to be installed to process protocol information. A network operating system is required for network services (data transmission, directory services, printing in the network) and thus has to be installed.

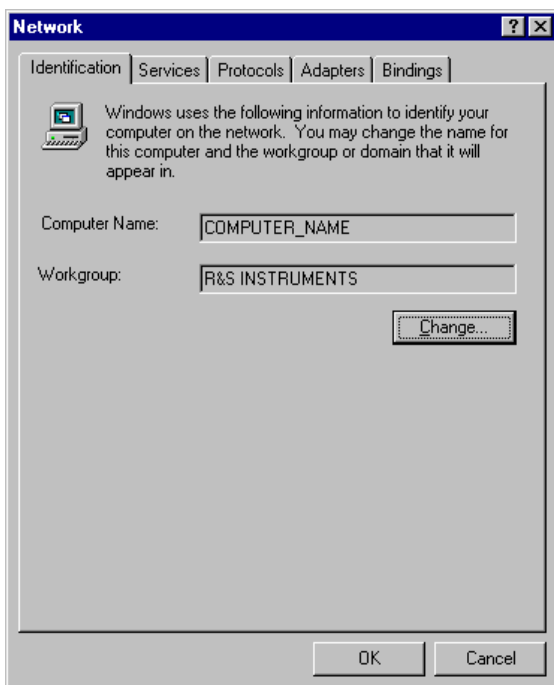
Calling up Configuration Menu for Network Settings

-
- Click "Start" in the task bar.
 - Click consecutively "Settings", "Control Panel" and "Network".

The "Network" configuration menu for network settings is opened.

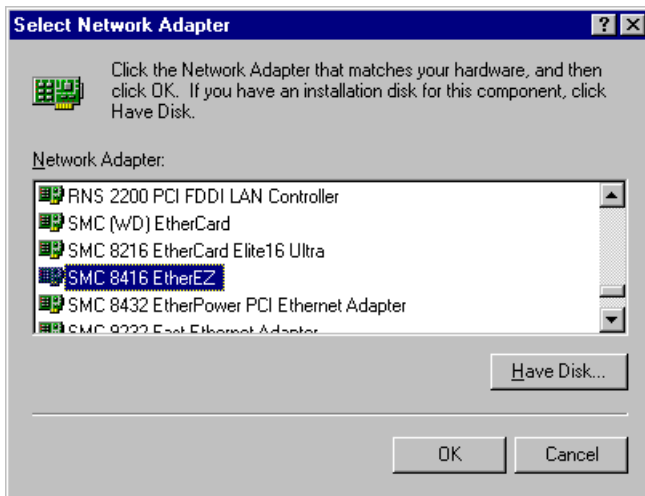
Registering the Identification

Note: It is important for the computer name to be unique in the network..



-
- Select "Identification".
 - Confirm computer and workgroup names with "OK" or enter new names in submenu "Change".

Installation and Configuration of the Driver for the Network Adapter



- Select "Adapter".
- Click "Add" and mark network driver "SMC 8416 EtherEZ" and select with "OK".
The query "Files.." is displayed.

- Answer it by clicking "Continue".
The "SMCEthernet Card Setup" window is displayed.

- Close the window with "OK".
Some files are copied and the network adapter is displayed under "Network Adapters".
The entry "MS Loopback Adapter" refers to a driver which ensures instrument control and should not be modified.

Note: *The network adapter settings must not be modified since this may cause problems to the instrument.*

Installation of Network Protocols

Note: *The network administrator knows which protocols are to be used..*

- Select "Protocol".
- Click "Add", mark the desired protocol and select with "OK".
This operation has to be performed several times when several protocols are selected.

- Execute the installation by clicking "Continue".

Note: *If a protocol requires further settings, they can be performed with "Properties" after marking the corresponding entry. If further settings are not possible, this field is gray.*

Installation of Network Services

To utilize the resources of the network it is necessary to install the corresponding services.

Note: *The network administrator knows which services are to be used.*

-
- Select "Services".
 - Click "Add", mark the desired service and select with "OK".

This operation has to be performed several times when several services are selected.

Some services are pre-installed and can be cleared with "Remove" if they are not needed.

-
- Execute the installation by clicking "Continue".

Note: *If a service requires further settings, they can be performed with "Properties" after marking the corresponding entry. If further settings are not possible, this field is gray.*

Terminating the Installation

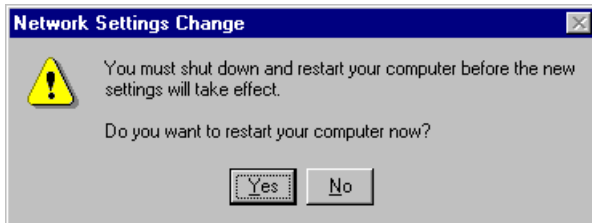
-
- Quit the "Network" configuration menu for network settings with "OK".

The settings are checked and processed. Missing information is queried.

-
- Answer the query "You must shutdown..." with "Yes".

The settings are valid after computer restart.

Note: *After the installation, the "Service Pack X" of Windows NT is to be re-installed, see "New Installation of Windows NT Software".*



Examples of Configurations

| Network | Protocols | Services | Notes |
|--|---|-------------------------------|--|
| NOVELL Netware | NWLink IPX/SPX Compatible Transport | Client Service for NetWare | The "Frame Type" used under "Protocols - Properties" should be set. |
| IP networks (FTP, TELNET, WWW, GOPHER, etc.) | TCP/IP Protocol | Simple TCP/IP Services | An "IP Address" unambiguous in the network should be set under "Protocols - Properties". |
| MICROSOFT network | NetBEUI Protocol or TCP/IP Protocol | Workstation Server | A name unambiguous in the network should be registered under "Identification - Computer Name". |

1.12.2.3 Operation

After installing the network operating system it is possible to transfer data between the device and other computers and to use printers in the network. A precondition for network operation is the authorization to use network resources. Resources may be access to the file directories of other computers or the use of a central printer. The network or server administrator will grant the authorizations. The network name of the resource and the corresponding authorization are required. Passwords protect the resources against improper use. A user name is normally assigned to every authorized user. The user also has a password. Resources may then be assigned to the user. The type of access, i.e. whether data are only read or also written as well as a shared access to data has to be defined. Other types are possible depending on the network operating system.

NOVELL

Operating system NETWARE from NOVELL is as server-supported system. Data transfer between the individual workstations is not possible. Data transfer is between workstation computers and a central computer, the server. This server provides storage capacity and the connection to the network printers. Like under DOS, the data on a server are organized in directories and are offered to the workstation as virtual drives. A virtual drive on a workstation is like a hard disk and data can be processed accordingly. This is called drive mapping. Also network printers can be addressed as normal printers.

Network operating system NOVELL is available in two forms: NETWARE 3 and NETWARE 4 NDS. In the previous version NETWARE 3, each server manages its own resources itself and is independent. A user has to be managed separately on each server. For NOVELL 4 NDS, all resources are managed in the NDS (NOVELL DIRECTORY SERVICE). The user only has to log in once and gains access to the resources released for him. The individual resources and the user are managed as objects in a hierarchical tree (NDS TREE). The position of the object in the tree is called CONTEXT for NETWARE and must be known in order to access the resources.

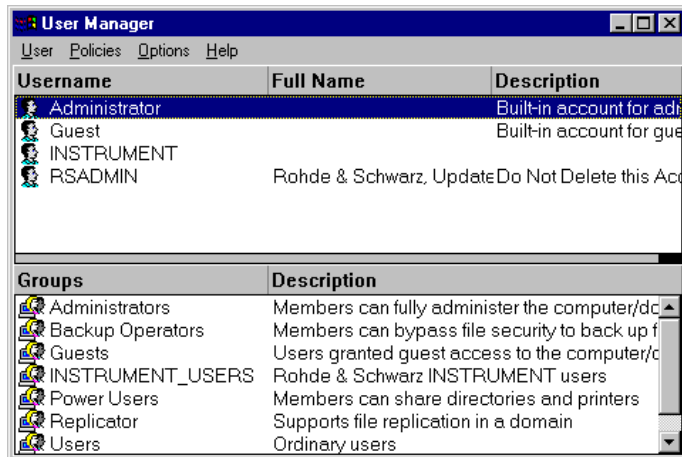
MICROSOFT

For MICROSOFT, data can be transferred between workstations (peer-to-peer) but also between workstations and servers. The servers can provide access to individual files as well as the connection to network printers. Like under DOS, the data on a server are organized in directories and are offered to the workstation as virtual drives. A virtual drive on a workstation is like a hard disk and data can be processed accordingly. This is called drive mapping. Also network printers can be addressed as normal printers. A connection to DOS, WINDOWS FOR WORKGROUPS, WINDOWS95, WINDOWS NT is possible.

Installing a user

After the network software has been installed, the instrument logs with an error message during the next start-up since there is no user "Instrument" (= user identification for NT autologin) in the network. It is therefore necessary to install a user which should be the same for Windows NT and for the network. The network administrator is responsible for the installation of new users in the network.

Note: *The installation of new users is possible only under the administrator identification (see section "Controller Function").*

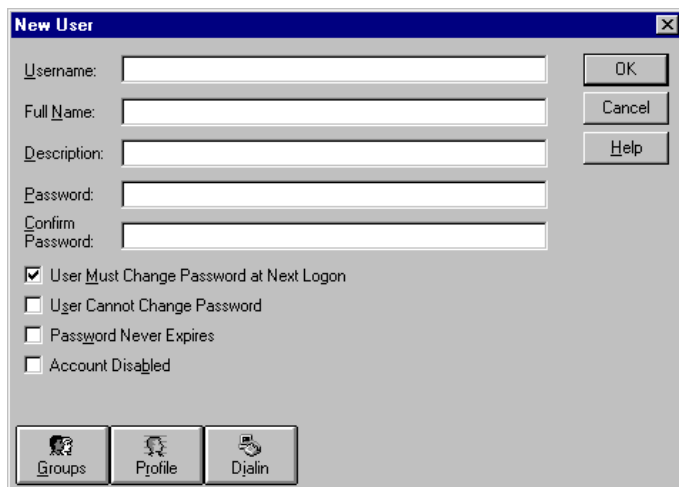


- Click "Start" in the task bar.
- Click consecutively "Programs" "Administrative Tools (Common)" and "User Manager".

The "User Manager" menu is opened.

- Click "User" and select "New User".

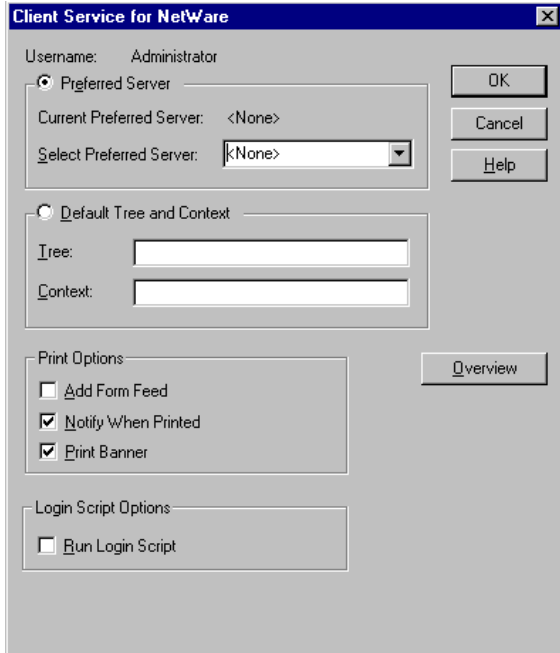
The menu "New User" for entering user data is opened.



- Fill in the lines "Username", "Password" and "Confirm Password" and confirm the entry with OK.

The user data should correspond to the network settings.

Only NOVELL network: Configure NOVELL Client



- Click "Start" in the task bar.
- Click consecutively "Settings", "Control Panel", "CSNW".

NOVELL 3.x

- Click "Preferred Server".
- Under "Select Preferred Server" select the NOVELL server for which the user has been installed.

NOVELL 4.x

- Click "Default Tree and Context" .
- Enter the NDS Tree under "Tree" and, under "Context", the hierarchical path for which the user has been installed.

Note: *These specifications can be obtained from the network administrator.*

Login in the Network

Network login is automatically performed with the operating system login. A prerequisite is that the user name and the password are the same under Windows NT and in the network.

Use of Network Drives

- Click "Start" in the task bar.
- Click consecutively "Programs" and "Windows NT Explorer".
- Click "Network" line in the "All Directories" list.

A list of available network drives is displayed.

- Click "Tools" and "Map Network Drive".
In the list "Shared Directories:" the network paths available in the network are displayed.
- Mark the desired network path.

- Select the drive under "Drive:"
- Activate "Reconnect at Logon:" if the link is to be automatically established at each unit start.
- Connect the network path to the selected drive with "OK".

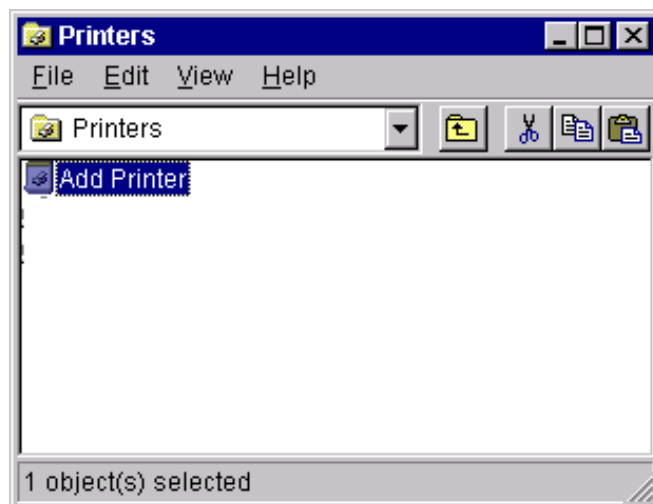
The user name and the password are queried. The drive is then displayed in the "All Directories" list of Explorer.

Note: *Only drives for which an authorization is available may be connected.*

Disconnect link:

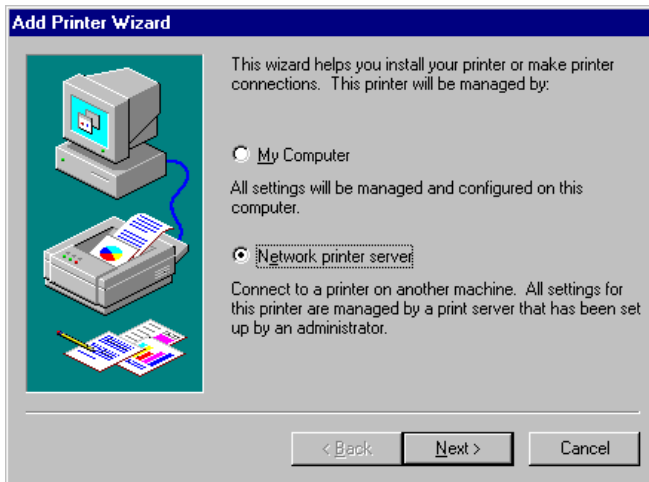
- Click "Tools" and "Disconnect Network Drive" in Explorer.
- Select under "Drive:" the drive whose connection is to be removed.
- Disconnect link with "OK". The query should be answered with "Yes".

Printing on a Network Printer



Select printer driver under Windows NT

- Press key combination <ALT> <SYSREQ>
The Windows NT screen is displayed.
-
- In the Start menu press first "Setting" and then "Printers".
The printer window is opened.



- Double-click line "Add Printer".

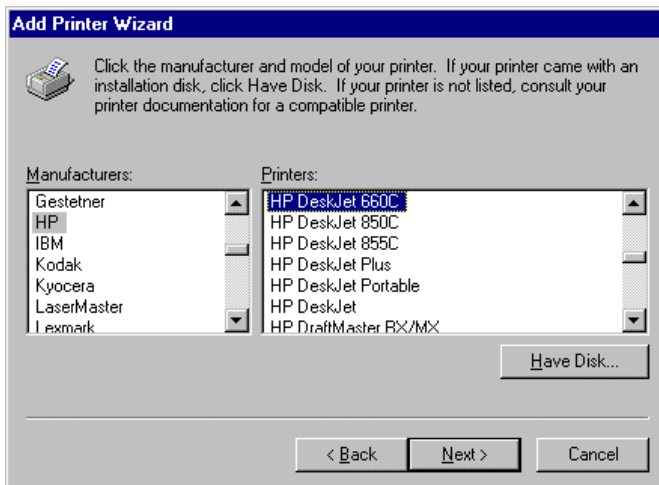
The "Add Printer Wizard" window is opened. This window leads through the following printer driver installation.

- Click first "Network Printer Source" and then "Next".

The list of available network printers is displayed.

- Mark the printer and select with "OK".

The available printer drivers are displayed. The left-hand selection table indicates the manufacturers and the right-hand one the available printer drivers.



- Mark the manufacturer in selection table "Manufacturers" and then the printer driver in selection table "Printers".



- Click "Next".

The window for starting a test page is displayed. The test print is for checking if the installation was successful.

- Switch on printer.
- Click Yes (recommended)".
- Click "Finish".

A test page is printed out if the installation was successful.

If the test page is not printed out or not completely, the Windows NT online help offers troubleshooting instructions under the entry "Printer Trouble Shooting".

The instrument has to be configured with this printer for the printout of the measurement screen. This configuration is described in this chapter in the section "Connecting an Output Device".

Server Function

With the server function data can be provided on the instrument for use in other computers. This is possible only in the MICROSOFT network. The server function is released after network installation as standard. If this is not required, it should be deactivated, see "Installation of Network Services".

The availability of instrument data in the network is controlled by releases. The release is a property of a file or of a directory. To grant a release, the object is to be marked in "Windows NT Explorer" and pressed by the right-hand mouse key. The release is performed under Properties -> Sharing by selecting "Shared As". Other computers can then access these objects with the names allocated under "Share Name". The online help gives further information on the network operation.

TCP/IP

The TCP/IP protocol allows files to be transmitted between different computer systems. A program running on both computers is required to control the data transfer. The same operating or file system need not be used by the two partners. A file transfer is possible between DOS/WINDOWS and UNIX, for example. One partner has to be configured as host the other as client or vice versa. The system performing several processes at the same time (UNIX) will normally be the host. The usual file transfer program used for TCP/IP is FTP (File Transfer Protocol). An FTP host is installed as standard on most of the UNIX systems.

After installing the TCP/IP services, a terminal link can be established with "Start" - "Programs" - "Accessories" - "Telnet" or a data transmission with FTP using "Start" - "Run" "ftp" - "OK". Thus, all controller systems can be accessed which support these universal protocols (UNIX, VMS, ...).

Further information is given in the NT online help which can be called up with "Help".

FTP

For a complete description of the functions and commands see the FTP documentation.

Establishing a connection

➤ Click "Start" and then "Run" in the task bar.

The program is started with the DOS command

```
FTP
```

The following command sets up the connection:

```
OPEN <xx.xx.xx.xx>
```

xx.xx.xx.xx = IP address, e.g. 89.0.0.13

File transmission

To transmit a file to the target system, the following command is used:

```
PUT <file name>
```

file name = name of file e.g. DATA.TXT.

To call a file from the target system, the following command is used:

```
GET<file name>
```

file name = name of file e.g. SETTING.DAT.

```
TYPE B
```

allows the transmission of files in the BINARY format, no conversion is performed.

```
TYPE A
```

allows the transmission of files in the ASCII format. Thus, control characters are converted so that the text files can be read on the target system, too.

Examples:

```
PUT C:\AUTOEXEC.BAT
```

sends the AUTOEXEC.BAT file to the target system.

```
LCD DATA
```

changes to subdirectory DATA in the computer function.

```
CD SETTING
```

changes to the subdirectory SETTING on the target system.

Changing directories

The command

```
LCD <path>
```

changes the directory as the corresponding DOS command.

```
LDIR
```

lists the directory.

These commands refer to the computer function of the instrument. If the 'L' preceding the commands is omitted, they apply to the target system.

2 Manual Operation

2.1 Introduction: Measurement Examples and Processing of Measured Values

This section describes typical measuring tasks for a network analyzer. Each step is explained in detail using an analyzer of the ZVR family so that the instrument can be immediately used without the need for learning all of the available functions.

The described measurement tasks are:

- Transmission measurement of magnitude and phase,
- Reflection measurement of magnitude and phase,
- Measurement of bandwidth, Q factor and shape factor of a filter.

The measurements are described systematically as listed below:

- Measurement task,
- Connection of the DUT,
- Reset of the instrument (Preset),
- Setting the instrument,
- Performance of a calibration (if required),
- Performance of the measurement.

All of the subsequent measurement examples assume the standard settings for the network analyzer. These are set by pressing the *PRESET* key in the *STATUS* key field (denoted in the following as *STATUS PRESET* key). The most important standard settings are listed in Table 2-1.

Table 2-1 Overview of the most important PRESET settings

| Parameter | Standard setting |
|-----------------------|--|
| Output level | -10 dBm |
| Frequency range | Start |
| | 9 kHz (ZVR,ZVRE,ZVRL with passive bridges) |
| | 300 kHz (ZVR,ZVRE,ZVRL with active bridges) |
| | 20 kHz (ZVC,ZVCE) |
| | Stop |
| | 4 GHz (ZVR,ZVRE, ZVRL) |
| | 8 GHz (ZVC,ZVCE) |
| Sweep variable | Frequency |
| Split screen | Single Channel |
| Diagram | Smith Diagram |
| Display | CH1 S11; CH2 S21; CH3 S12; CH4 S22 (ZVRL: CH1 S11; CH2 S21; CH3 S21; CH4 S11) |
| IF bandwidth | 10 kHz |
| Number of test points | 401 |
| Sweep time | automatic |

2.1.1 Transmission Measurements – Measurement of Gain and Loss

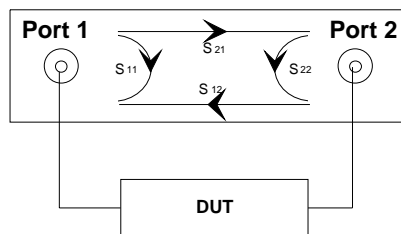
2.1.1.1 Measurement Task

The transmission measurement measures the characteristic of the insertion loss or the gain factor of a DUT in relation to the frequency.

The insertion loss/gain of a DUT is the ratio of the amplitude of the output signal to the amplitude of the input signal.

In this example, the magnitude and phase of a DUT of 2.17 to 2.27 GHz are represented in a cartesian or polar diagram which is then printed out.

2.1.1.2 Connection of the DUT



Connect the DUT

- Connect the input of the DUT to PORT 1 and the output to PORT 2.

2.1.1.3 Preset

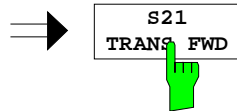
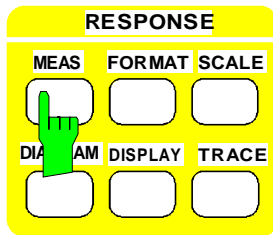


Reset the instrument

- Press the *STATUS PRESET* key.
- Confirm preset OK.

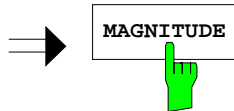
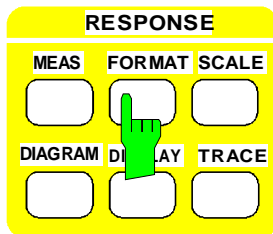
2.1.1.4 Setting the Analyzer

Following *PRESET*, channel 1 performs a S_{11} measurement and represents it in the Smith diagram. The transmission measurement described in this example is to be represented in various diagrams.



1. Set measurement type (S21, or forward transmission)

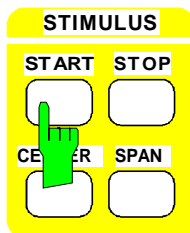
- Press *RESPONSE MEAS* key.
- Press S21 TRANS FWD softkey in the MEAS menu (denoted in the following as the *RESPONSE MEAS - S21 TRANS FWD* softkey).



2. Set format of representation (magnitude)

- Press *RESPONSE FORMAT* key.
- Press *RESPONSE FORMAT - MAGNITUDE* softkey.

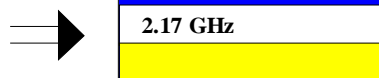
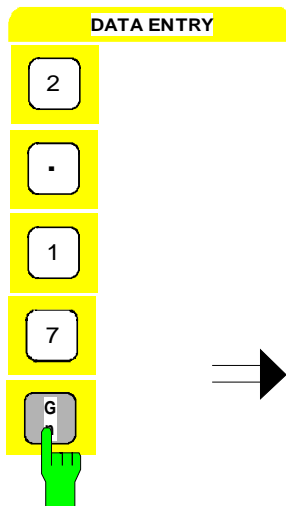
By default (following *PRESET*), the "magnitude" diagram is a Cartesian diagram with 10 dB/Div.



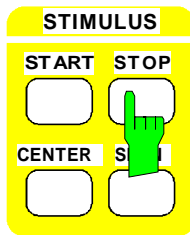
3. Specify desired frequency range for the display

Set start frequency

- Press *STIMULUS START* key. The data entry field is opened.

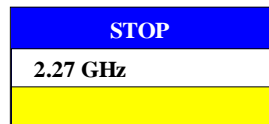
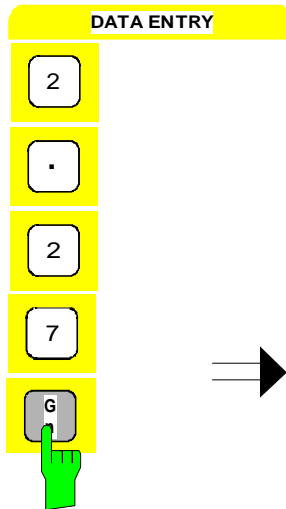


- Enter 2.17 via the numeric keypad and terminate the entry using the G/n key.



Set stop frequency

- Press *STIMULUS STOP* key. The data entry field is opened.

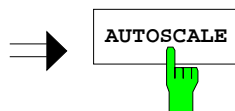
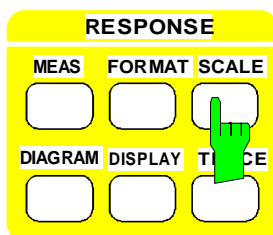


- Enter 2.27 via the numeric keypad and terminate the entry using the G/n key.

4. Positioning the trace in the diagram

a) Automatic positioning

Autoscale means that the trace is automatically fitted in the diagram. This is achieved by positioning the reference line in the center of the diagram and setting the reference value and *SCALE/DIV* such that the complete curve appears in the diagram (see Fig. 2-1).



- Press *RESPONSE SCALE* key.
- Press *RESPONSE SCALE - AUTOSCALE* softkey.

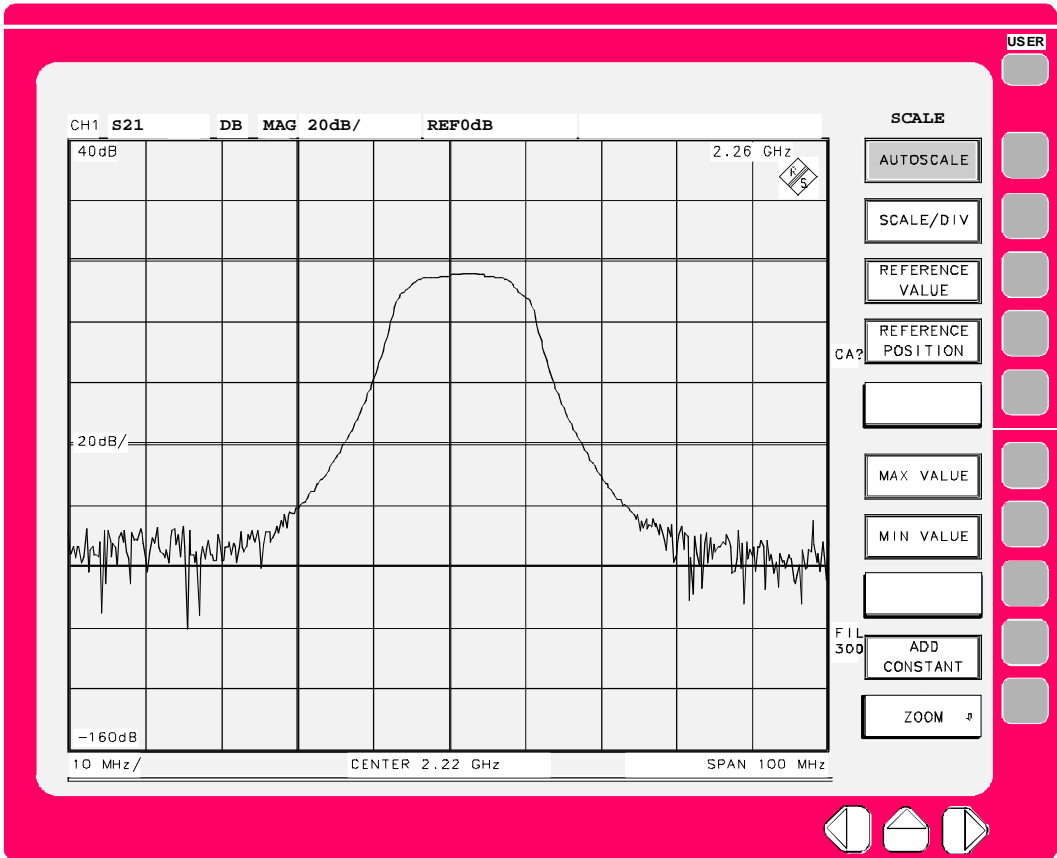
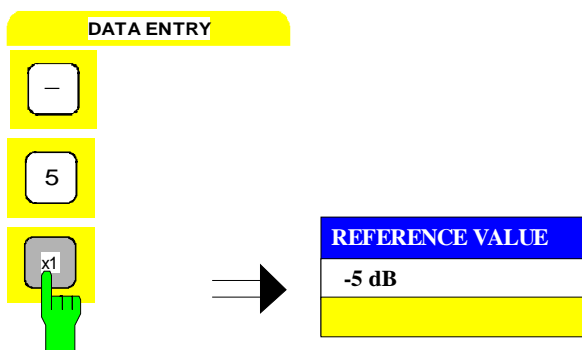
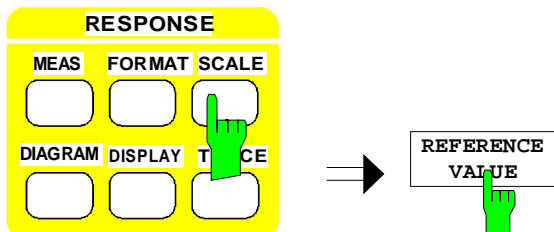
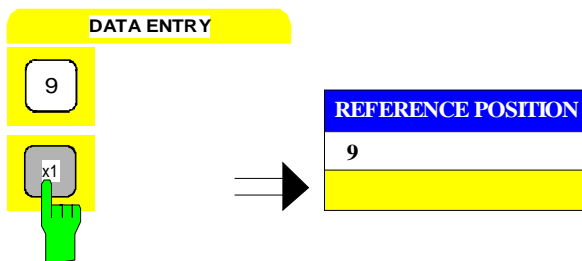
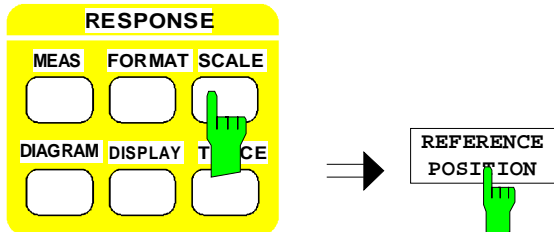


Fig. 2-1 Measurement display screen with an autoscaled trace



Alternative

b) Manual positioning

Enter the following values.

- Reference position 9
- Reference value -5 dB
- Scaling 10 dB / DIV

Set reference position

The 2nd horizontal diagram line from the top is to coincide with the reference line.

- Press *RESPONSE SCALE* key.
- Press *RESPONSE SCALE - REFERENCE POSITION* softkey.

The data entry field for the reference position is opened.

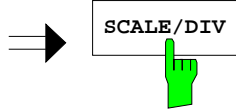
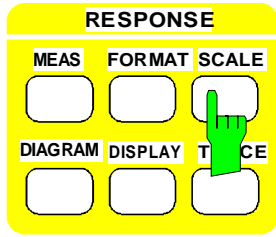
- Enter 9 via the numeric keypad and terminate the entry using the x1 key.

Set reference value

The reference value is to be equal to -5 dB.

- Press *RESPONSE SCALE* key in the key field.
- Press *RESPONSE SCALE - REFERENCE VALUE* softkey.
The data entry field for the reference value is opened.

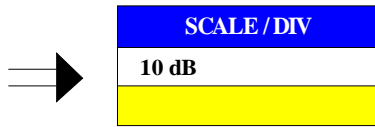
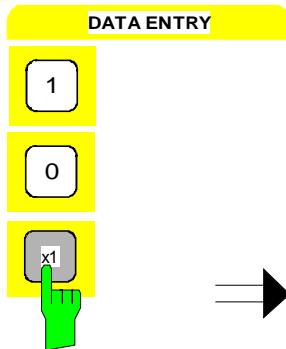
- Enter -5 via the numeric keypad and terminate the entry using the x1 key.



Set scaling

The distance between the scaling lines is to be equal to 10 dB.

- Press *RESPONSE SCALE* key.
- Press *RESPONSE SCALE - SCALE/DIV* key. The data entry field for the scaling is opened.



- Enter 10 via the numeric keypad and terminate the entry using the x1 key.

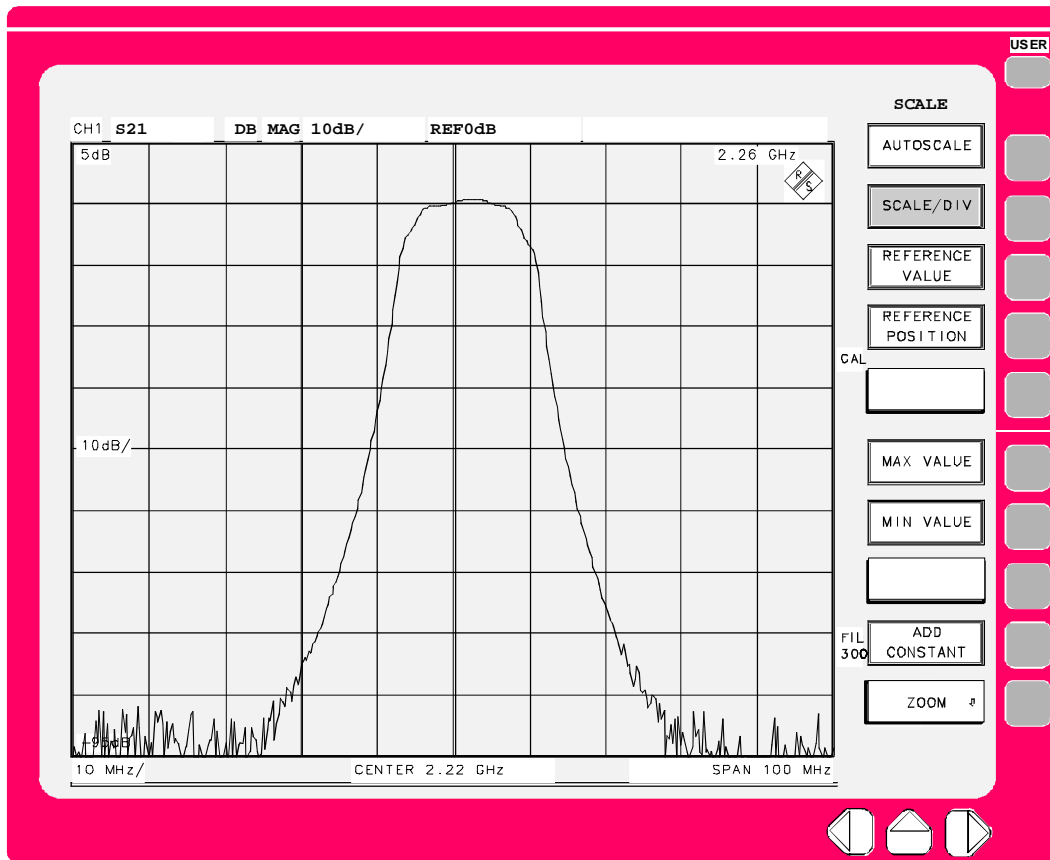
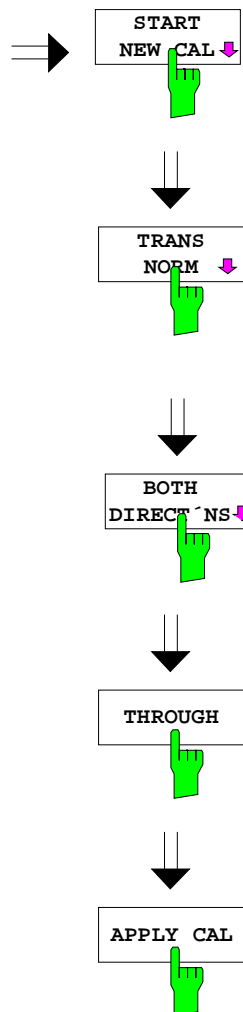


Figure 2-2 Measurement display screen after manual scaling

2.1.1.5 Instrument Calibration

The analyzer calibration menu offers selection of various system error corrections. A simple and fast method is the normalization calibration which calibrates the frequency response of the test setup. (Refer to Section 2.15 for further information on various calibration methods).



1. Replace DUT by through-connection.

2. Start calibration

- Press *CAL CAL* key.
A system error correction with request of all additional information required is thus started.
- Press *CAL CAL - START NEW CAL* softkey.

- Press *CAL CAL - START NEW CAL - TRANS NORM* softkey.

- Press *CAL CAL - START NEW CAL - TRANS NORM - BOTH DIRECT'NS* softkey.

- Press *CAL CAL - START NEW CAL - TRANS NORM - BOTH DIRECT'NS - THROUGH* softkey.

- Press *CAL CAL - START NEW CAL - TRANS NORM - BOTH DIRECT'NS - APPLY CAL* softkey.
The measurement is thus terminated, calculation of the correction values is started and the system error correction is switched on.

2.1.1.6 Performing the Measurement

1. Remove through-connection.

2. Connect DUT.

3. If necessary: repeat trace positioning (cf. 2.1.1.4, Setting the Analyzer).

4. Display of magnitude in cartesian coordinates

➤ Press *RESPONSE FORMAT* key.

➤ Press *RESPONSE FORMAT - MAGNITUDE* softkey.

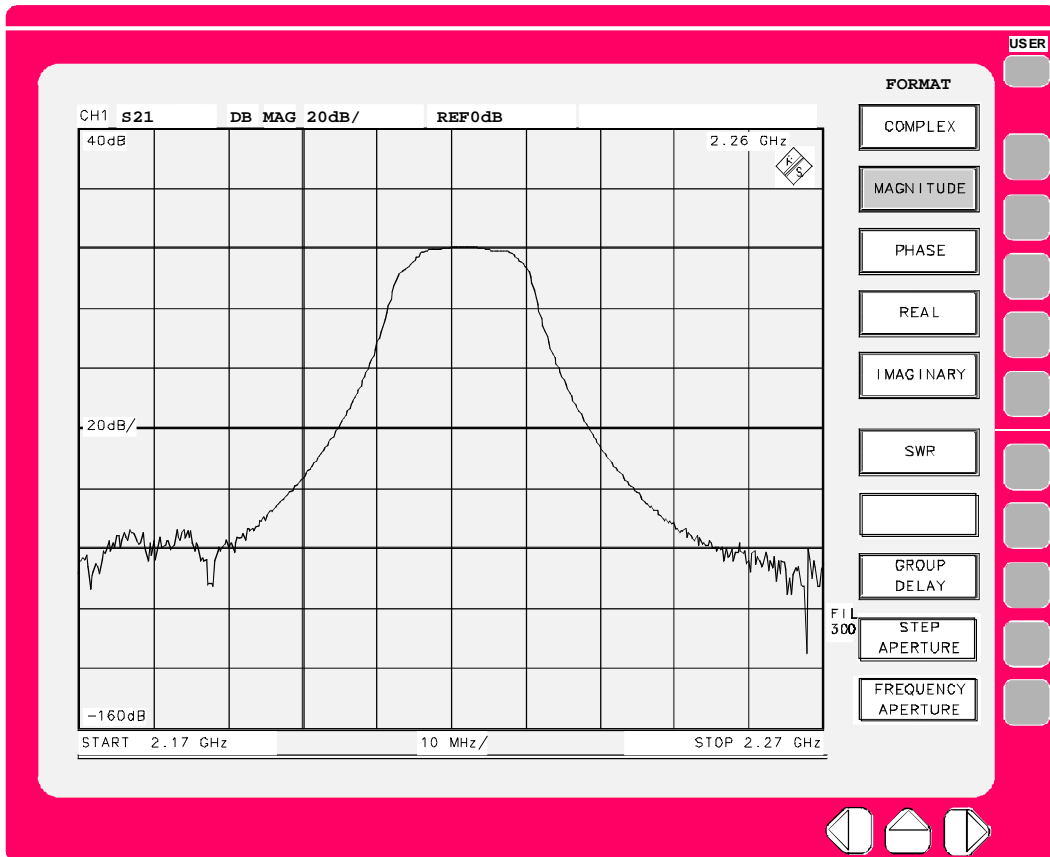
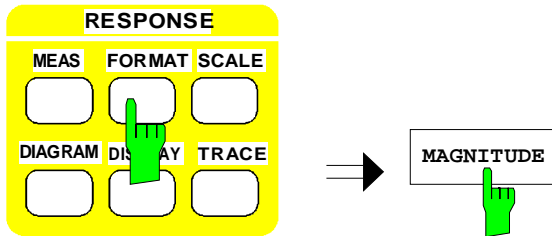
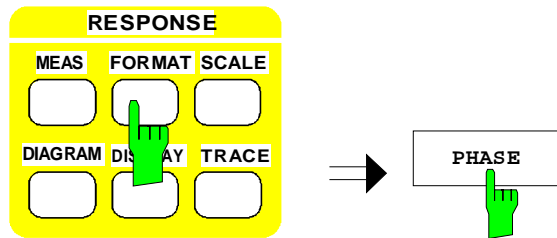


Fig. 2-3 Display of magnitude in cartesian coordinates



5. Display of phase in cartesian coordinates

- Press *RESPONSE FORMAT* key.
- Press *RESPONSE FORMAT - PHASE* softkey.

By default (following *STATUS PRESET*), the phase is represented in cartesian coordinates with a specified range of -225° to $+225^\circ$.

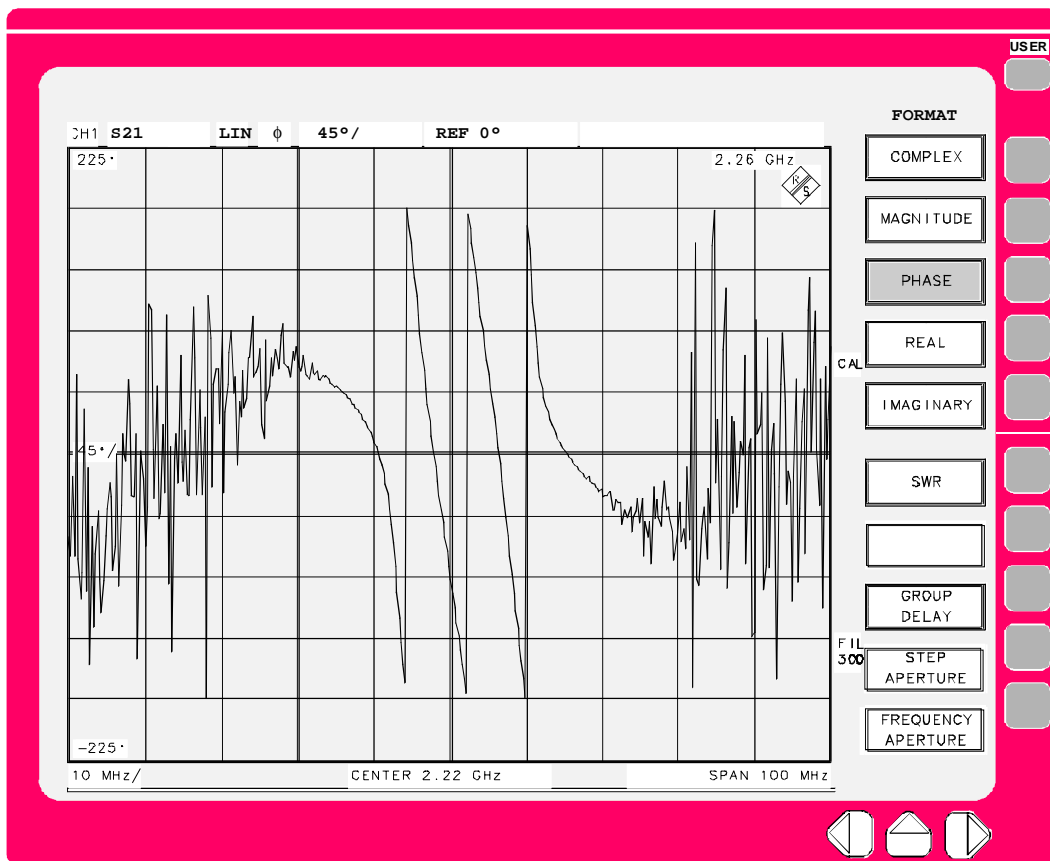
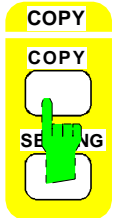


Fig. 2-4 Display of phase in cartesian coordinates

2.1.1.7 Output of Measurement Results

By default (following *STATUS PRESET*), a printer driver for a plotter with HPGL capability and connection to the IEC bus (address 4) is active.



1. Start printing

- Connect plotter to the IEC bus.
- Press *COPY COPY* key.

Apart from being output to a printer or plotter, screen displays may also be stored to disc in order to be further processed on a PC or be merged in documents. All modifications of printer or plotter default settings are made in the *COPY SETTINGS* menu (Section 2.5.2).

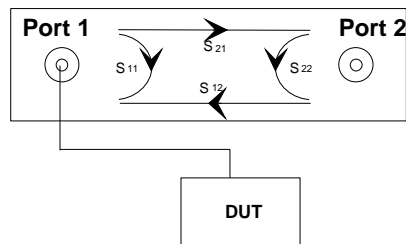
2.1.2 Reflection Measurements

2.1.2.1 Measurement Task

The reflection coefficient is the complex ratio between the wave quantity reflected from the input of a DUT and the wave quantity of the signal propagating towards this input. The logarithmic inverse of the magnitude of the reflection coefficient is also called matching and is ≥ 0 for passive DUTs.

This example illustrates how magnitude and phase of a DUT's reflection coefficient in the frequency range between 2.17 GHz and 2.27 GHz can be represented in Cartesian coordinates or in a Smith diagram.

2.1.2.2 Connection of the DUT



Connect the DUT

- Connect the port of the DUT to be measured to PORT 1 of the network analyzer. Channel 1 is active.

2.1.2.3 Preset



Reset the instrument.

- Press *STATUS PRESET* key.
- Confirm preset OK.

2.1.2.4 Setting the Analyzer

With standard settings, channel 1 performs a S₁₁ measurement and displays it in a Smith diagram. The reflection measurement in this examples is to be represented in various diagrams. For Steps 1 to 3 see transmission measurement, Section 2.1.1.4, Steps 2 to 5.

1. Set display format (magnitude).

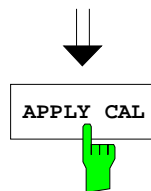
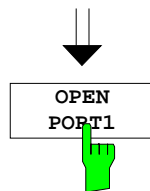
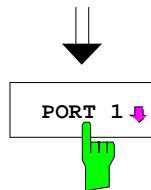
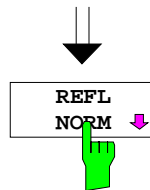
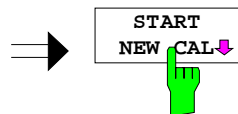
2. Specify desired frequency range

3. Positioning the measuring curve

Automatic and manual positioning

2.1.2.5 Instrument Calibration

The analyzer calibration menu offers selection of various methods for a system error correction. A simple and fast method is the normalization calibration which calibrates the frequency response of the bridge and transmission lines, if fitted. (Refer to Section 2.15 for further information on calibration methods).



1. Unscrew DUT and provide test port with open

Caution:

Note that the physical data of the open standard used must be entered previously via CAL CAL-MODIFY CAL KIT).

2. Start calibration

- Press CAL CAL key.
A system error correction with request of all additional information required is thus started.
- Press CAL CAL - START NEW CAL softkey.
- Press CAL CAL - START NEW CAL - REFL NORM softkey
- Press CAL CAL - START NEW CAL - REFL NORM - PORT1 softkey.
- Press CAL CAL - START NEW CAL - REFL NORM - PORT1 - OPEN PORT1 softkey.
- Press CAL CAL - START NEW CAL - REFL NORM - PORT1 - APPLY CAL softkey.
The measurement is thus terminated, calculation of the correction values is started and the system error correction is switched on.

2.1.2.6 Performing the Measurement

1. Remove open circuit.
2. Connect DUT
3. If necessary: repeat trace positioning, (see Section 2.1.2.4).
4. Display of magnitude in cartesian coordinates

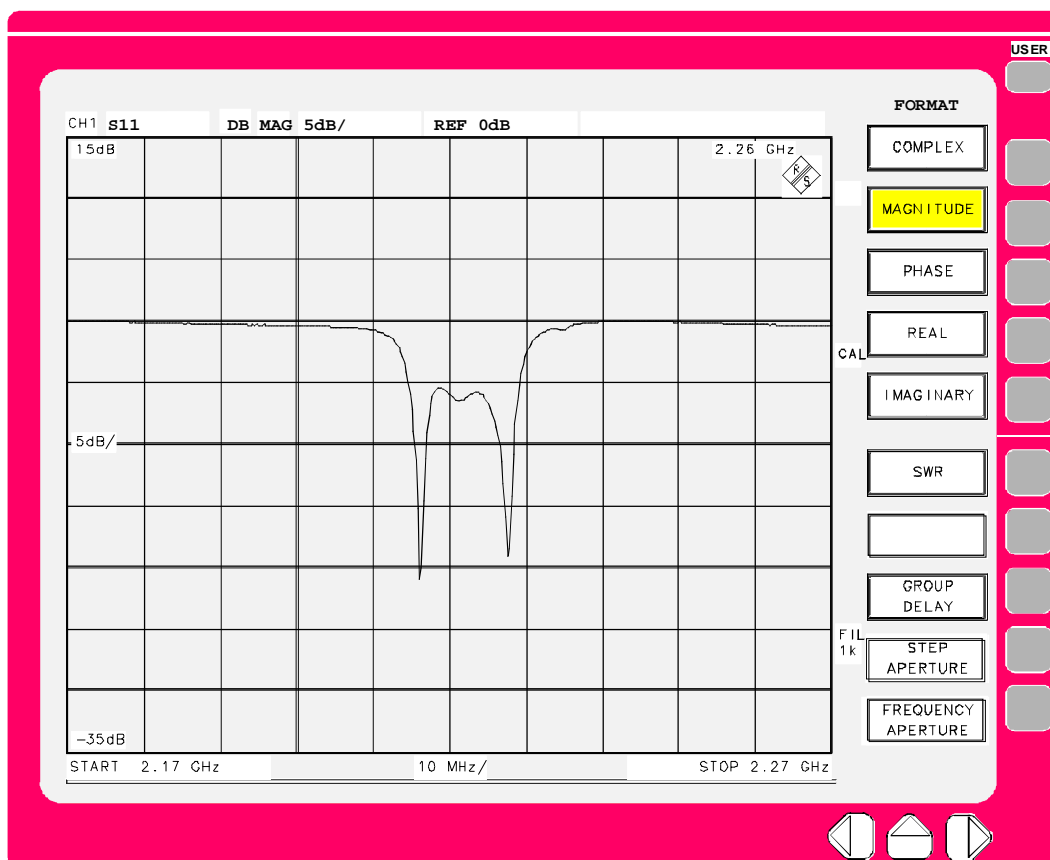


Fig. 2-5 Display of magnitude in cartesian coordinates

5. Display of phase in cartesian coordinates

see Section 2.1.1, transmission measurement

With standard settings, the "phase" is represented in cartesian coordinates with a specified range of -225° to $+225^\circ$.

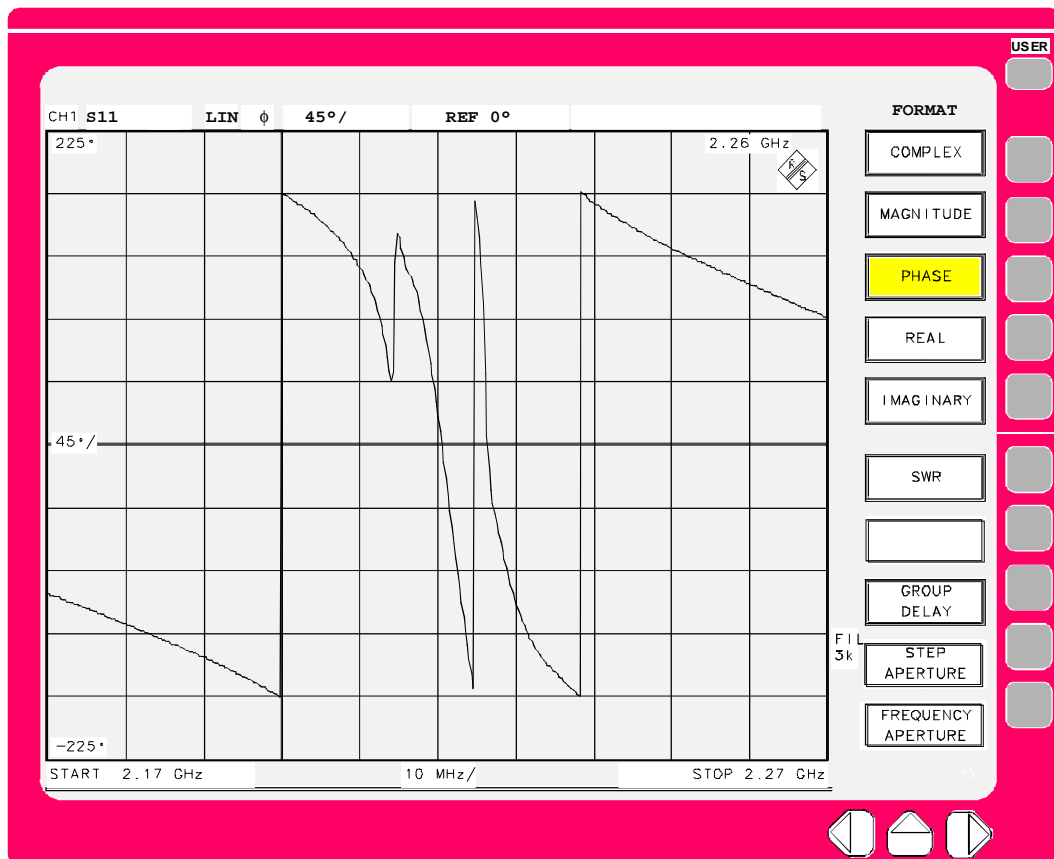
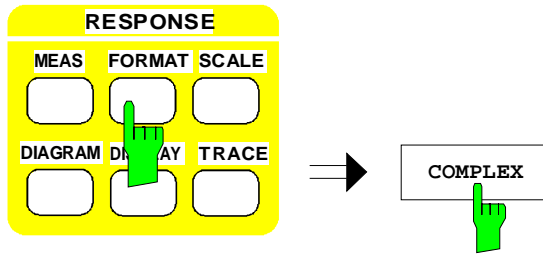


Fig. 2-6 Display of phase in cartesian coordinates



6. Display of the reflection coefficient in the Smith diagram

- Press *RESPONSE FORMAT* key.
- Press *RESPONSE FORMAT - COMPLEX* softkey.

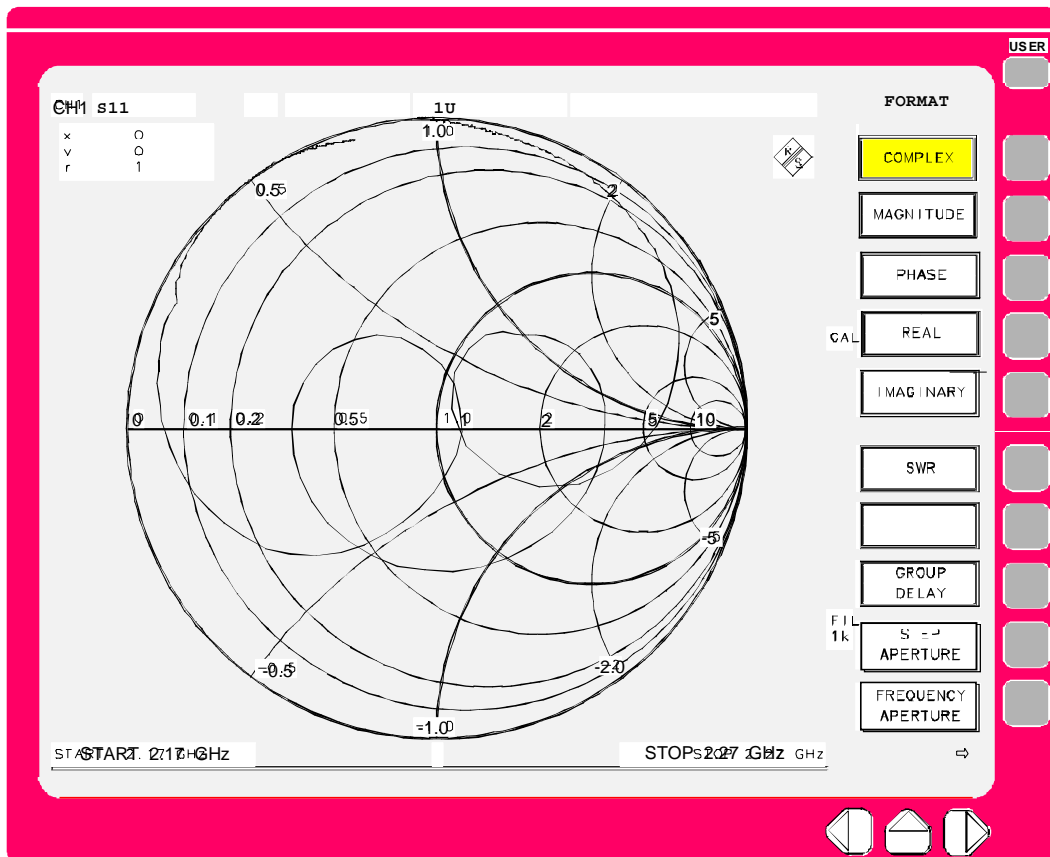


Fig. 2-7 Display of the reflection coefficient in the Smith diagram

2.1.3 Filter Measurements – Measurements of Bandwidth, Q Factor and Shape Factor

2.1.3.1 Measurement Task

The parameters bandwidth, Q factor and shape factor characterize a bandpass or bandstop filter and can be measured automatically by the network analyzer.

The **bandwidth** represents the frequency difference between two points of the same attenuation (often 3 dB) of the passband curve.

The **Q factor** of bandpass or bandstop filter is defined as the ratio between the center frequency and the 3 dB bandwidth.

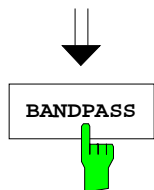
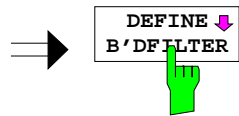
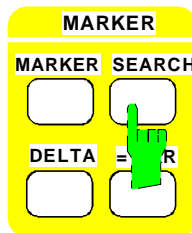
The **shape factor** represents the ratio between the bandwidth (3 or 6 dB) in the passband and the bandwidth in the stopband (60 dB) and is a measure for the steepness of the filter skirt.

This example shows how to measure a bandpass. A bandstop is measured analogously.

2.1.3.2 Reset, Setting and Calibration of the Instrument

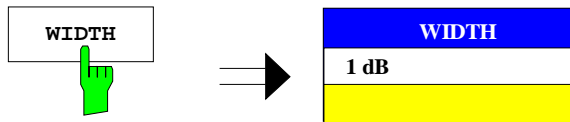
Before starting the measurement, the instrument must be set and calibrated as for the transmission measurement (see Section 2.1.1, transmission measurement, Sections 2.1.1.2 to 2.1.1.5).

2.1.3.3 Measurement of the Filter Parameters



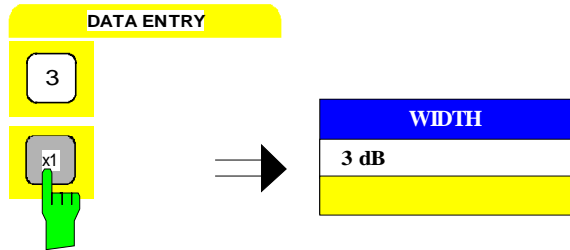
1. Bandpass selection

- Press *MARKER SEARCH* key.
- Press *MARKER SEARCH - DEFINE B'DFILTER* softkey.
- Press *MARKER SEARCH - DEFINE B'DFILTER - BANDPASS* softkey.

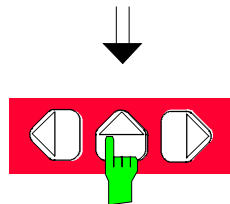



2. Determination of the 3 dB bandwidth of a bandpass

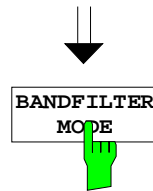
- Press *DEFINE B'DFILTER - WIDTH* softkey.



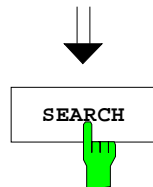
- Enter 3 via the numeric keypad and terminate the entry using the x1 key.



- Press menu change key  to return to the *MARKER SEARCH* menu.



- Press *MARKER SEARCH - BANDFILTER MODE* softkey to activate bandfilter measurement.



- Press *MARKER SEARCH - BANDFILTER MODE - SEARCH* softkey.

Two auxiliary markers are now displayed on the trace at the determined bandwidth points, one marker at the determined center frequency. The corresponding bandwidth is indicated in the marker-info line (see Fig. 2-8).

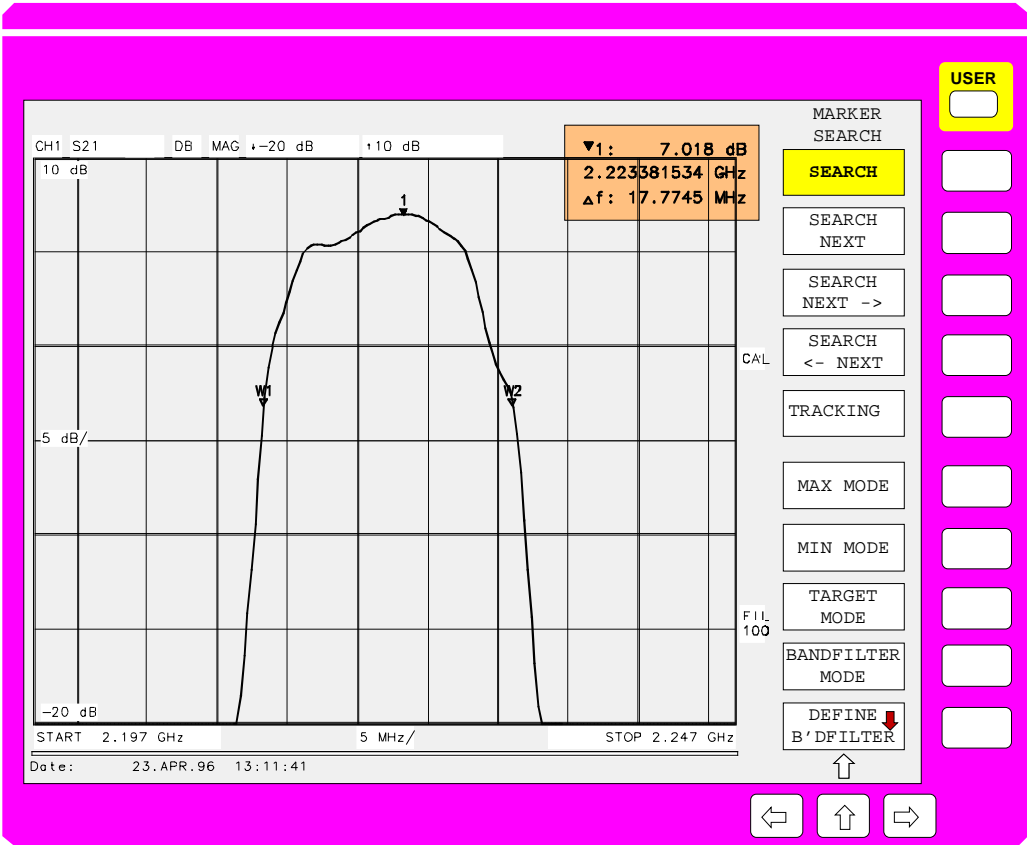


Fig. 2-8 Determination of the 3 dB bandwidth of a bandpass

3. Determination of the Q-Factor

DEFINE
B'DFILTER



QUALITY
FACTOR




SEARCH



➤ Press *MARKER SEARCH - DEFINE B'DFILTER* softkey.

➤ Press *MARKER SEARCH - DEFINE B'DFILTER - QUALITY FACTOR* softkey. The filter quality is indicated in the marker-info line.

➤ Press menu change key  to return to the *MARKER SEARCH* menu.

➤ Press *MARKER SEARCH - SEARCH* softkey. Two auxiliary markers appear at the the 3 dB bandwidth points and one marker at the center frequency.

The quality factor is displayed (see Fig. 2-9).

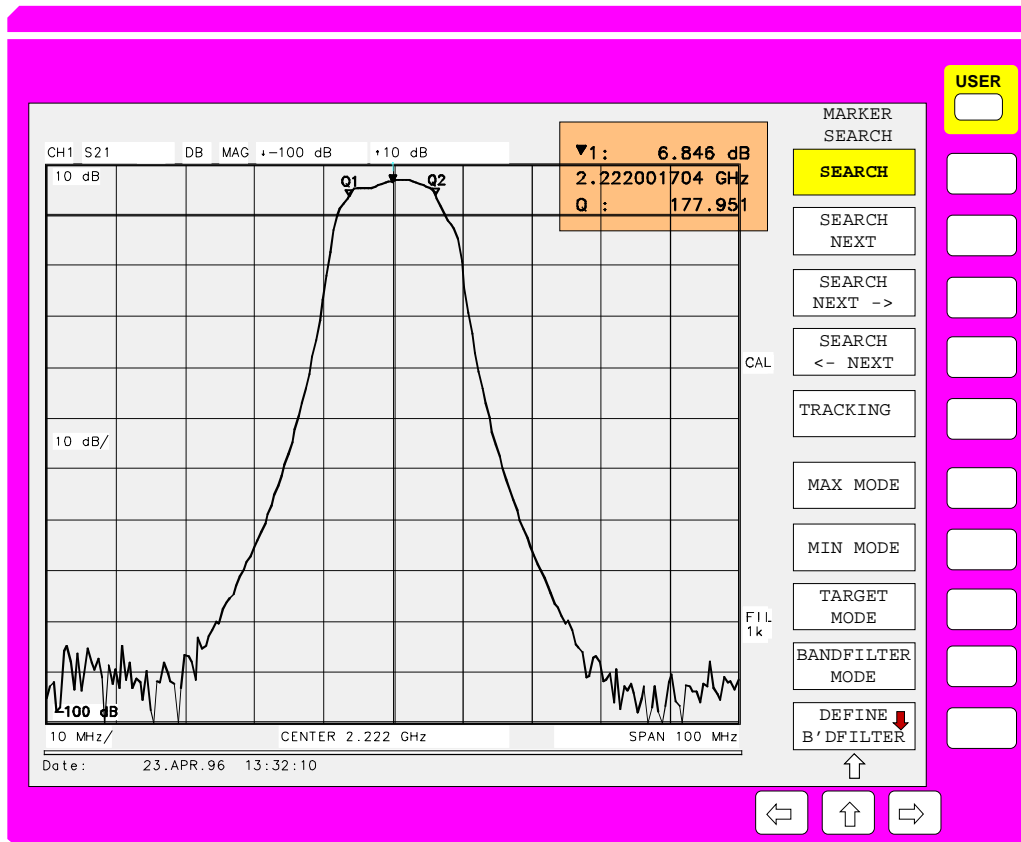



Fig. 2-9 Determination of the Q-factor

4. Shape factor 60 dB/3 dB

The shape factor is a measure for the filter skirt selectivity. It is calculated from the 60-dB and 3 dB bandwidths according to the formula

$$\text{Shape factor } 60 \text{ dB}/3 \text{ dB} = \Delta f_{60 \text{ dB}} / \Delta f_{3 \text{ dB}}$$

➤ Press *MARKER SEARCH - DEFINE B'DFILTER - SHAPEFACT*. 60dB/3dB softkey.

➤ Press menu change key  to return to the *MARKER SEARCH* menu.

➤ Press *MARKER SEARCH - SEARCH* softkey.

The measurement result of the shape factor is indicated in the marker-info line. (see Fig. 2-10).

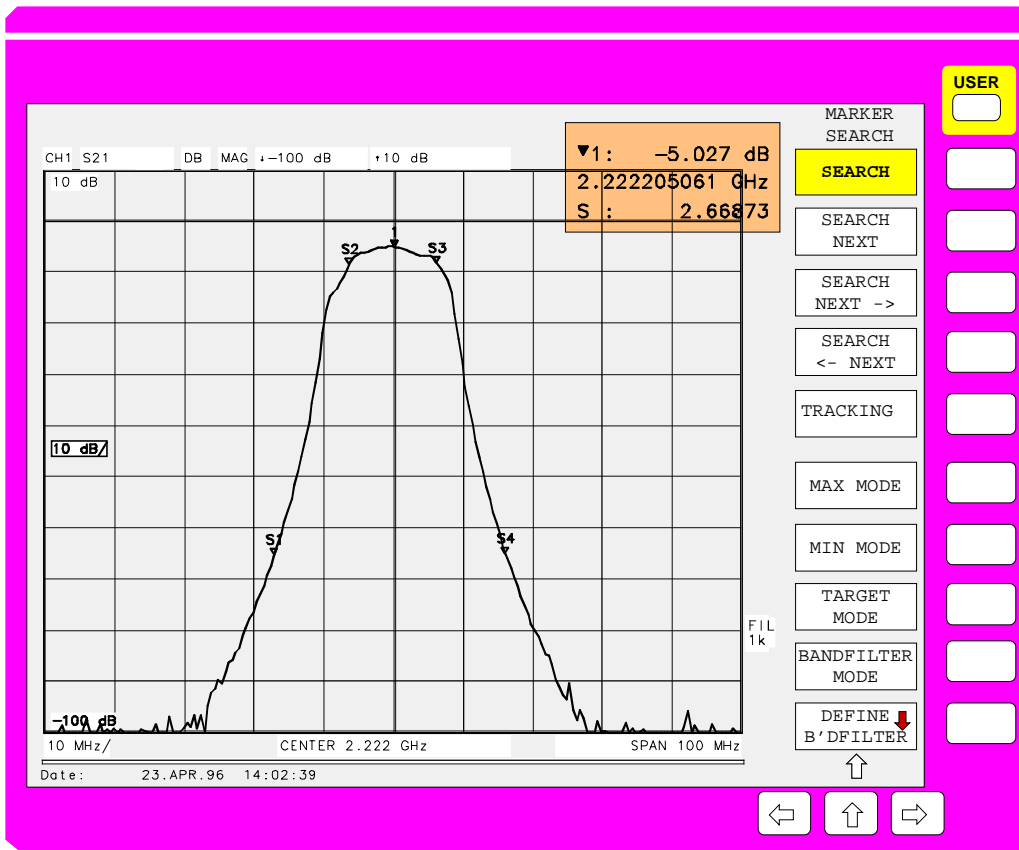
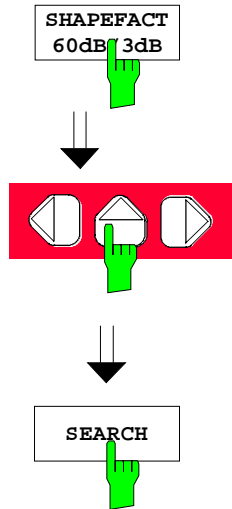


Fig. 2-10 Shape factor 60 dB/3 dB

2.1.4 Processing of Measured Values

The numbers in brackets in the text refer to Fig. 2-11 which shows the processing sequence of measured values of a ZVR display channel in bidirectional operation. Note that for reasons of clarity the diagram does not contain any recursive measurement sequences which arise, e.g., in compression and intercept point measurements. However, these higher-level test loops are based on the single measurements described in the following.

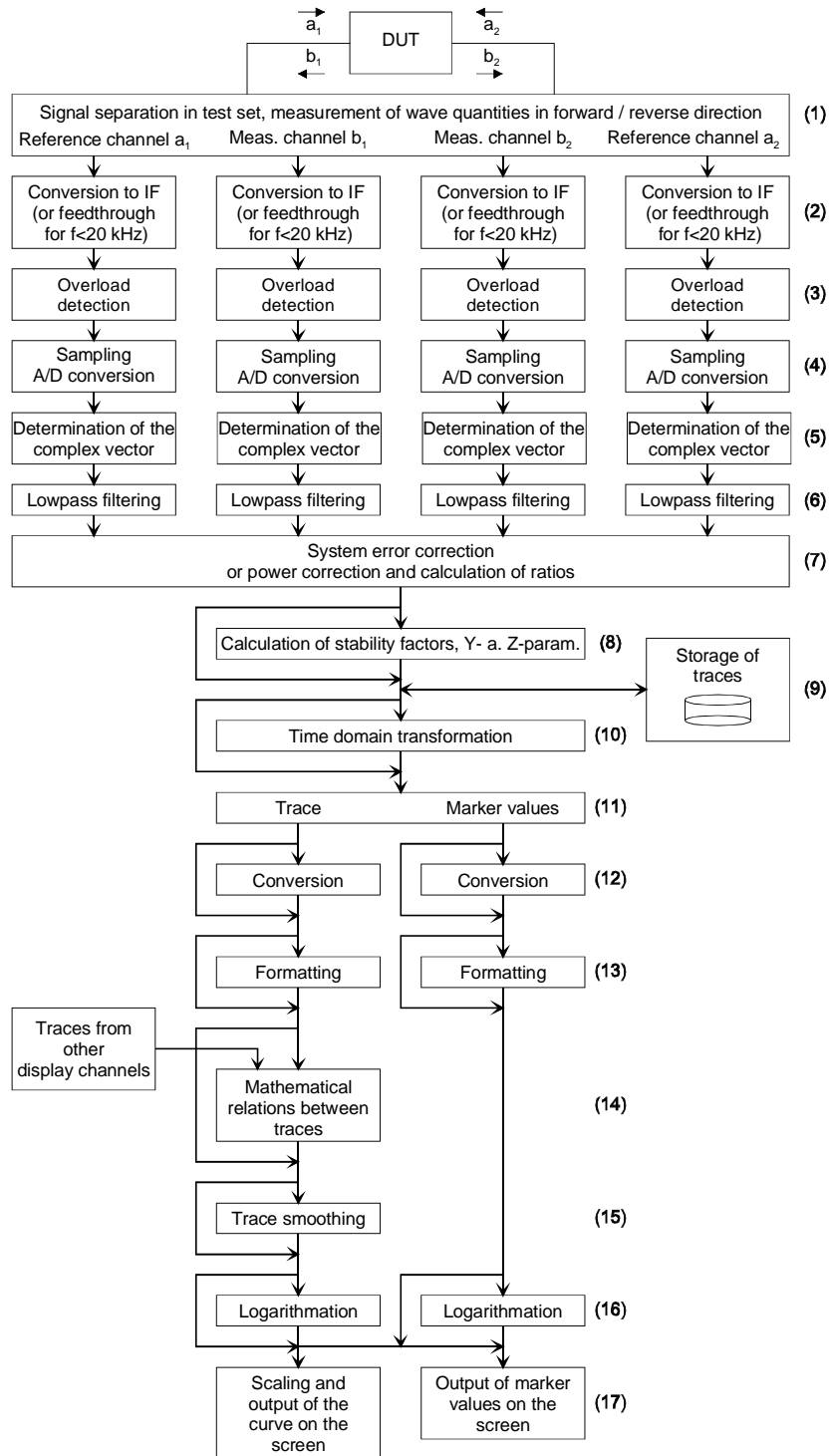


Fig. 2-11 Processing sequence of measured values for a ZVR display channel in bidirectional operation

Scattering parameters (S-parameters in short) are defined as ratios of the wave quantities. The following equation applies to a two-port DUT:

$$S_{11} := \frac{b_1}{a_1} \quad S_{21} := \frac{b_2}{a_1} \quad S_{12} := \frac{b_1}{a_2} \quad S_{22} := \frac{b_2}{a_2}$$

The wave quantities in the numerator – b_1 and b_2 – are coupled out in the network analyzer test set (1) and converted in separate receive channels to an intermediate frequency (2). These receive channels are referred to as measurement channels. The parameters in the denominator a_1 and a_2 are obtained from the so-called reference channels on models ZVR, ZVC, ZVK and ZVM. On ZVRE and ZVCE, however, a_1 and a_2 are measured on the same physical receive channel, the assignment being dependent on the through direction of the RF switch. On the unidirectional model ZVRL, there is only reference channel a_1 . Each receive channel is subject to an analog overload detection (3). If the signal level is too high, a message appears on the screen. The receive channels are sampled synchronously in parallel and A/D-converted (4).

In the first digital processing stage the amplitude and phase of each wave quantity, i.e. complex vectors, are determined by downconversion to 0 Hz (5). The absolute phase of a wave quantity depends on the random IF phase at the beginning of sampling, it changes for each sweep. The phase difference of two wave quantities, which is given by the DUT, however, is independent of the sampling. The complex vectors of wave quantities are lowpass-filtered (6) in the signal processor, the bandwidth can be set via *AVG – IF BANDWIDTH*.

In the subsequent stage, the parameter selected by the user in the *MEAS* menu is formed from the wave quantities and cleared from systematic errors (7). Wave quantities (menu *MEAS – WAVE QUANTITY*) and quotients of wave quantities (menu *MEAS – RATIO*) are only power-corrected, i.e. the amplitude value is multiplied by a correction factor. For S-parameters, however, a system error correction is performed. For the corrected value of one S-parameter, the vector values of all measured wave quantities are used. In case of full two-port calibration, e.g. according to the TOM method, these are the four wave quantities measured in the forward and reverse direction, summing up to 8 values in total.

If a stability factor is selected as measured quantity in the menu *MEAS*, it is calculated from the complex values of all the four system-error corrected two-port S-parameters (8). The four parameters are determined in the system-error correction stage (7) of the current display channel.

The power- or system-corrected measured values can be stored (menu *TRACE*) (9)). Storage immediately after correction has the advantage that the subsequent processing steps can also be applied to stored traces as required by the user, which allows flexible handling of these data.

The next stage, which is only available with Option ZVR-B2, allows the transformation of S-parameters to the time domain (10). The transformation result is still a complex S-parameter irrespective of whether it is displayed in the time domain or (after transforming it back) again in the frequency domain.

If the conversion or formatting selected for the markers (softkeys *NORMAL – MARKER CONVERTS* and *MARKER FORMAT*) differs from the conversion or formatting of the trace, the processing chain of the display channel is divided into two parallel branches (11).

Menu *COMPLEX CONVERTS* or *NORMAL - MARKER CONVERTS* allows optional conversion of the complex S-parameters to other complex quantities (12). The inversion of the complex value as well as the normalized or absolute impedance or admittance can be selected here.

The S-parameter or ratio of wave quantities which is complex up to this stage can be either retained or converted to a scalar value. This conversion is referred to as formatting (13) and can be selected in the *FORMAT* or *NORMAL - MARKER FORMAT* menu. For wave quantities or conversion gains (*MEAS – RATIO – CONV GAIN...*), due to the already mentioned random phase, only magnitude formatting (*FORMAT - MAGNITUDE*) is available. In addition to the general mathematical formatings magnitude and phase or real and imaginary part, there are other formats with special relevance to the high frequencies, for example standing wave ratio and group delay. To calculate the latter the phases of two sweep points separated by a predefined frequency spacing (the so-called aperture) are used. It is even possible to select the aperture independent of the current test-point grid. If complex conversion to an absolute impedance or admittance is selected, the imaginary part of these quantities can be converted

to the corresponding inductance or capacitance. If the DUT is a line, it is possible to determine its phase delay and its electrical or mechanical length from the phase difference between the first and the last sweep point.

After formatting a mathematical relation between the trace and stored data or current measured values from other display channels (*TRACE – SHOW MATH*) can be defined (14). For this the sweep points of the traces must coincide. Stored traces are adapted to the conversion and formatting of the current display channel. Measured values from other display channels must be compatible with the current channel (scalar/complex and same unit).

The trace can be optionally smoothed (*TRACE – SMOOTHING* menu, 15).

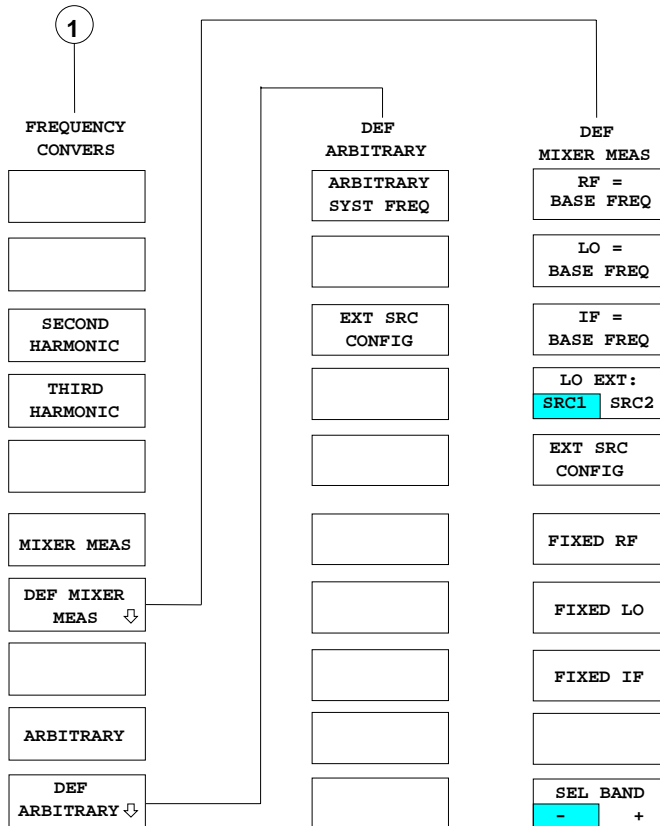
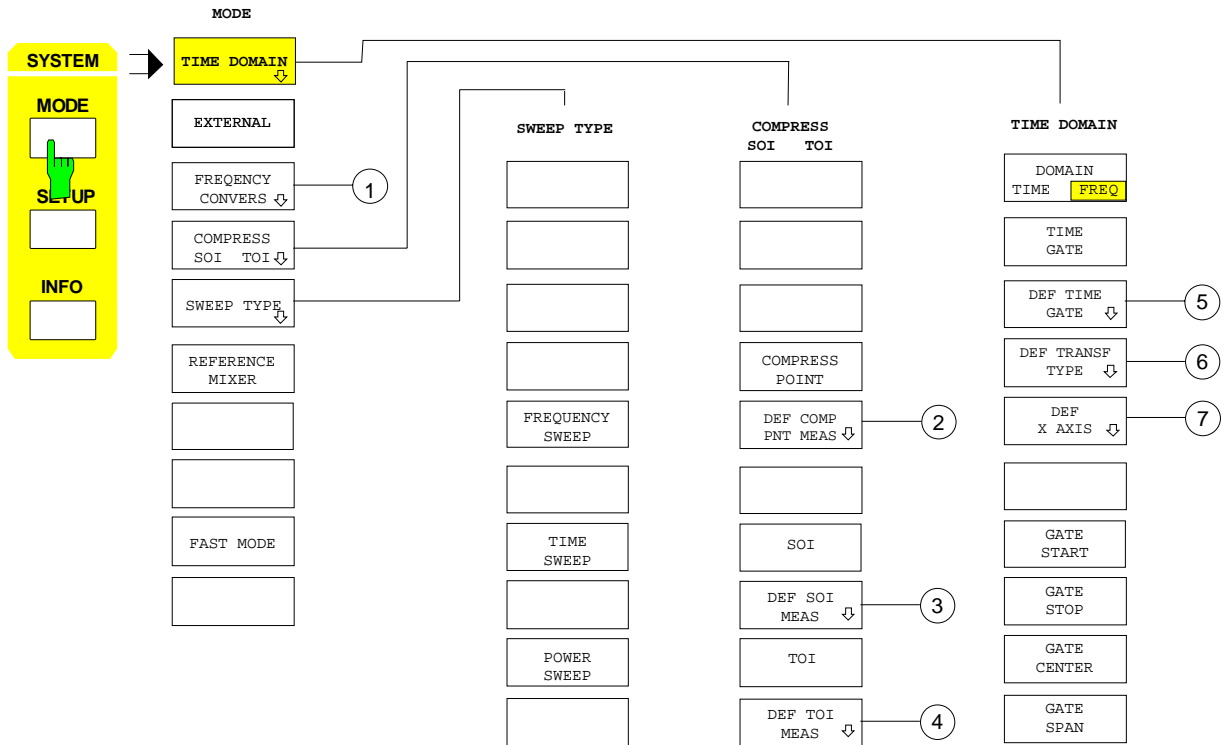
In the following processing step, the measured values are adapted to the diagram selected in the *DIAGRAM* menu. If it is a linear Cartesian or complex diagram, the values are simply fed through. If, however, scalar values are displayed on logarithmic Cartesian diagrams (logarithmic or dB grid in y direction), the values have to be logarithmized. Accordingly, logarithmation of the magnitude is required for displaying complex values in logarithmic polar diagrams (radial logarithmic or dB grid).

If the conversion and formatting is identical for the markers and for the trace, the marker values are taken from the trace data, otherwise from the separate marker processing path.

Finally, the trace is scaled to the display range selected in the *SCALE* menu and displayed on the screen together with the markers (17).

2.2 Menu Overview

2.2.1 SYSTEM Key Group



2

- DEF COMP
- PNT MEAS
- SRC POWER
- MAX LIMIT
- SRC POWER
- MIN LIMIT
- SETTLING
- TIME
- COMP POINT
- INP **OUTP**
- X DB COMP
- POINT
- CHK VALUE
- SETTINGS
- EXT SRC
- CONFIG
- INT SRC
- EXT SRC1
- EXT SRC2

3

- DEF SO I
- MEAS
- SRC POWER
- MAX LIMIT
- SRC POWER
- MIN LIMIT
- SETTLING
- TIME
- INTC POINT
- INP **OUTP**
- FREQ OFFS
- OF 2ND SRC
- MEAS FREQ
- SUM **DIFF**
- CHK VALUE
- SETTINGS
- INT SRC
- EXT SRC1
- INT SRC
- EXT SRC2
- EXT SRC1
- EXT SRC2

4

- DEF TO I
- MEAS
- SRC POWER
- MAX LIMIT
- SRC POWER
- MIN LIMIT
- SETTLING
- TIME
- INTC POINT
- INP **OUTP**
- FREQ OFFS
- OF 2ND SRC
- MEAS SIDEB
- LSB **USB**
- CHK VALUE
- SETTINGS
- INT SRC
- EXT SRC1
- INT SRC
- EXT SRC2
- EXT SRC1
- EXT SRC2

5

- DEF TIME
- GATE
- STEEPEST
- EDGES
- STEEP
- EDGES
- NORMAL**
- GATE**
- MAXIMUM
- FLATNESS
- ARBITRARY
- GATE SHAPE
- GATE
- START
- GATE
- STOP
- GATE**
- CENTER**
- GATE
- SPAN

6

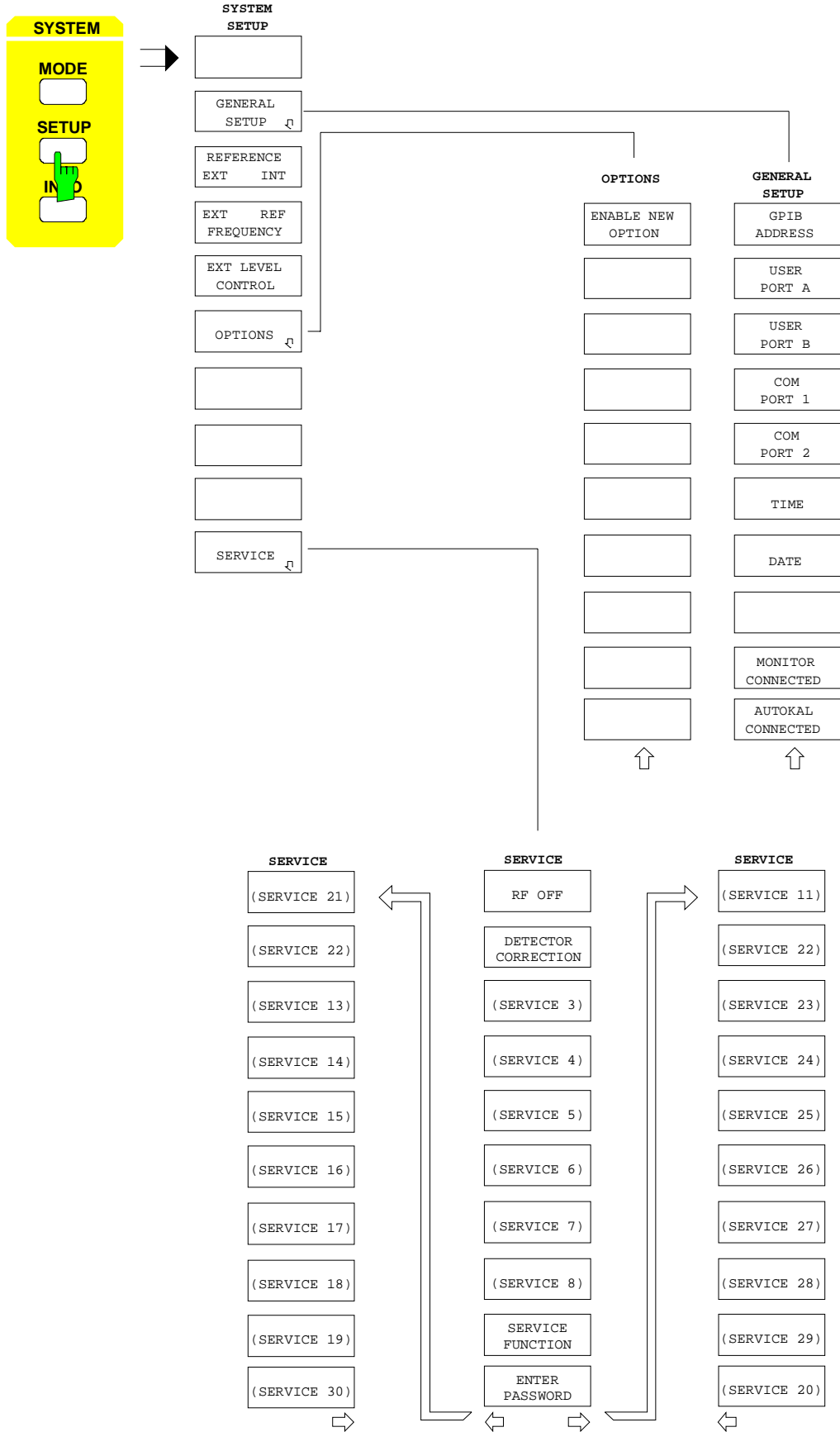
- DEF TRANSF
- TYPE
- FFT**
- CHIRP
- IMPULSE**
- STEP
- BANDPASS**
- LOWPASS
- SET FREQS
- LOWPASS ↓
- LOWPASS DC
- S-PARAM
- NO
- PROFILING
- LOW FIRST
- SIDELOBE
- NORMAL**
- PROFILE**
- STEEP
- FALLOFF
- ARBITRARY
- SIDELOBES

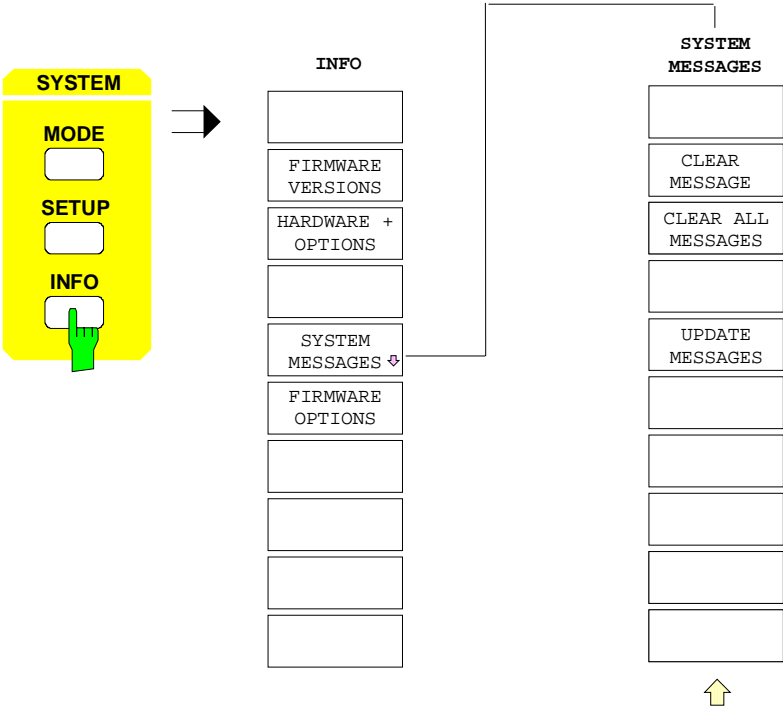
SET FREQS
LOWPASS

-
-
-
- KEEP
- STOP FREQ
- KEEP FREQ
- STEP WIDTH
- USE MIN
- STEP WIDTH
-
-
-

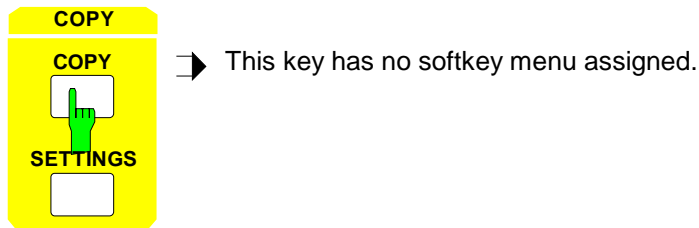
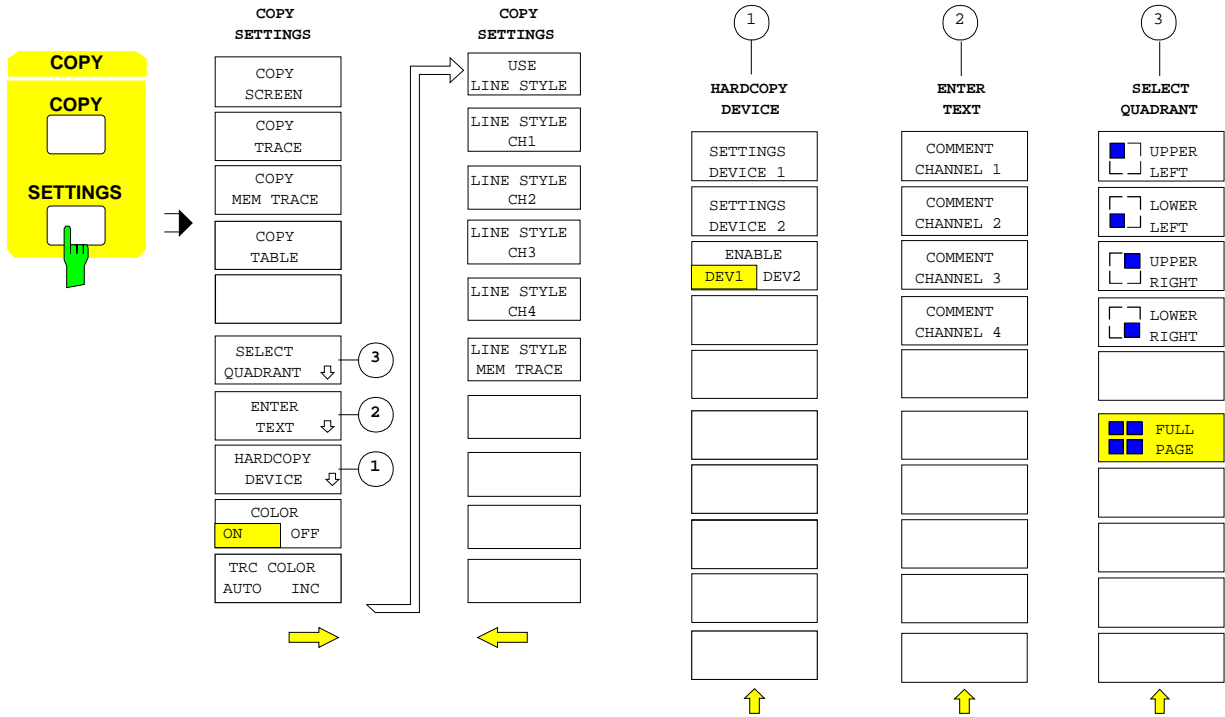
7

- DEF
- X AXIS
-
-
-
-
- X-AXIS**
- TIME**
- X-AXIS
- DISTANCE
- X-AXIS
- DISTANCE/2
-
-

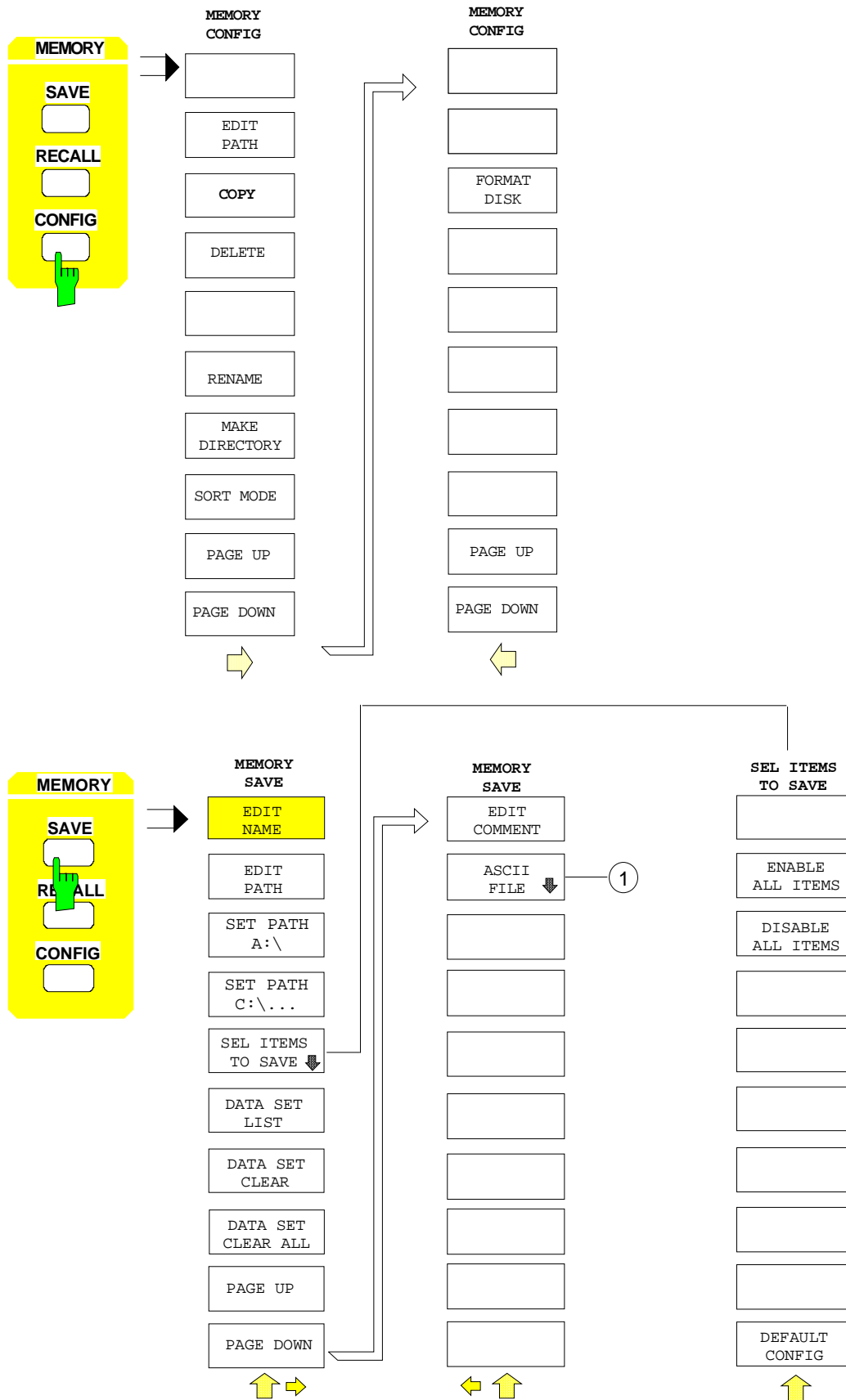


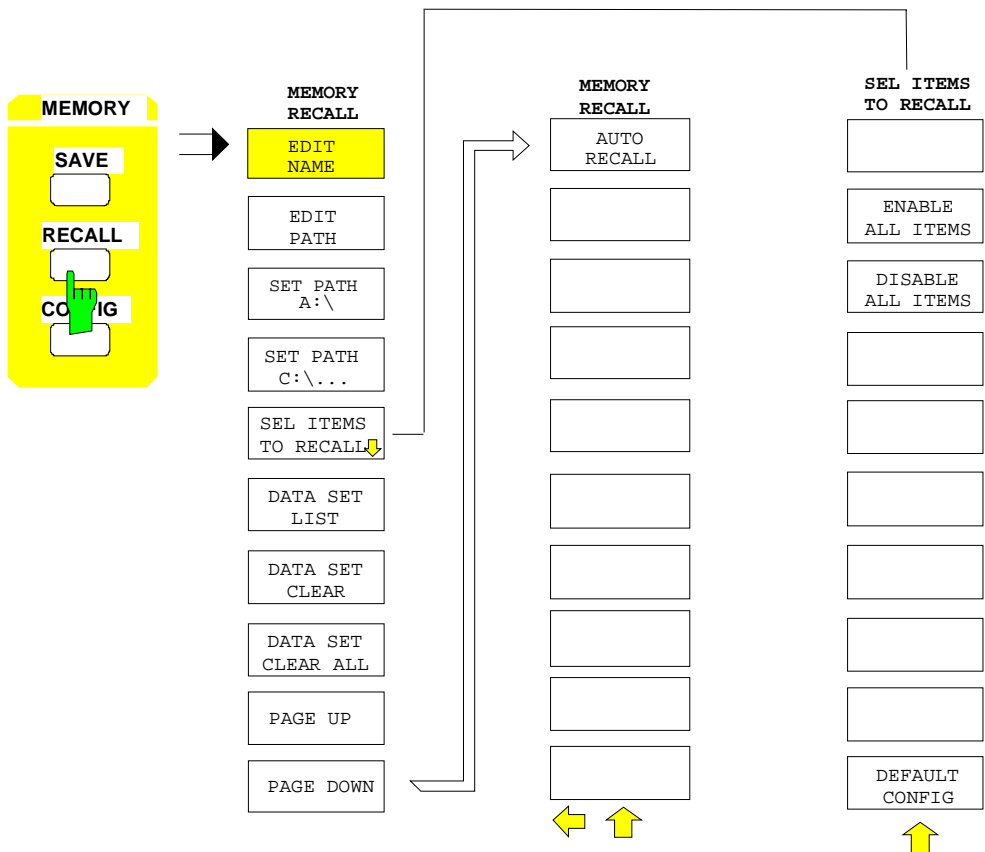
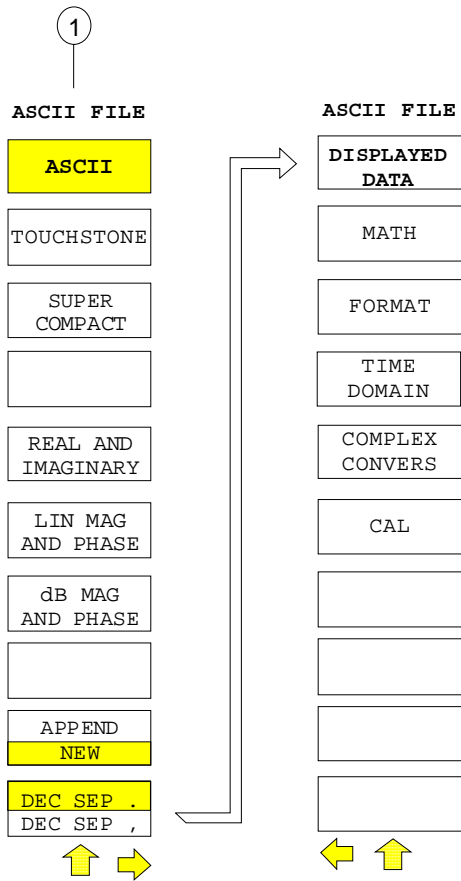


2.2.2 COPY Key Group

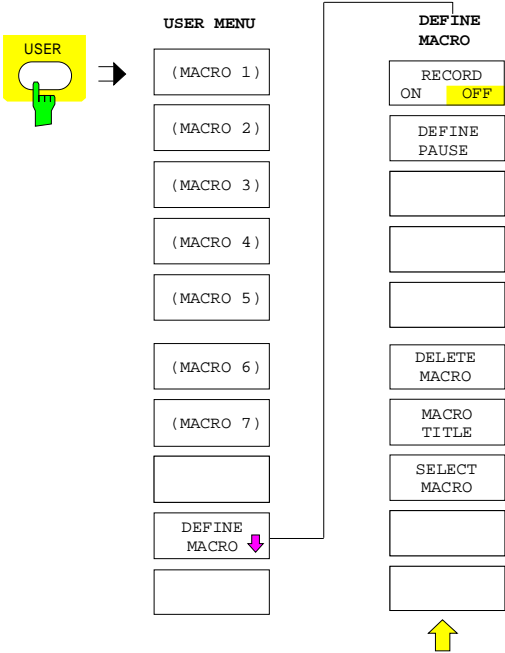


2.2.3 MEMORY Key Group

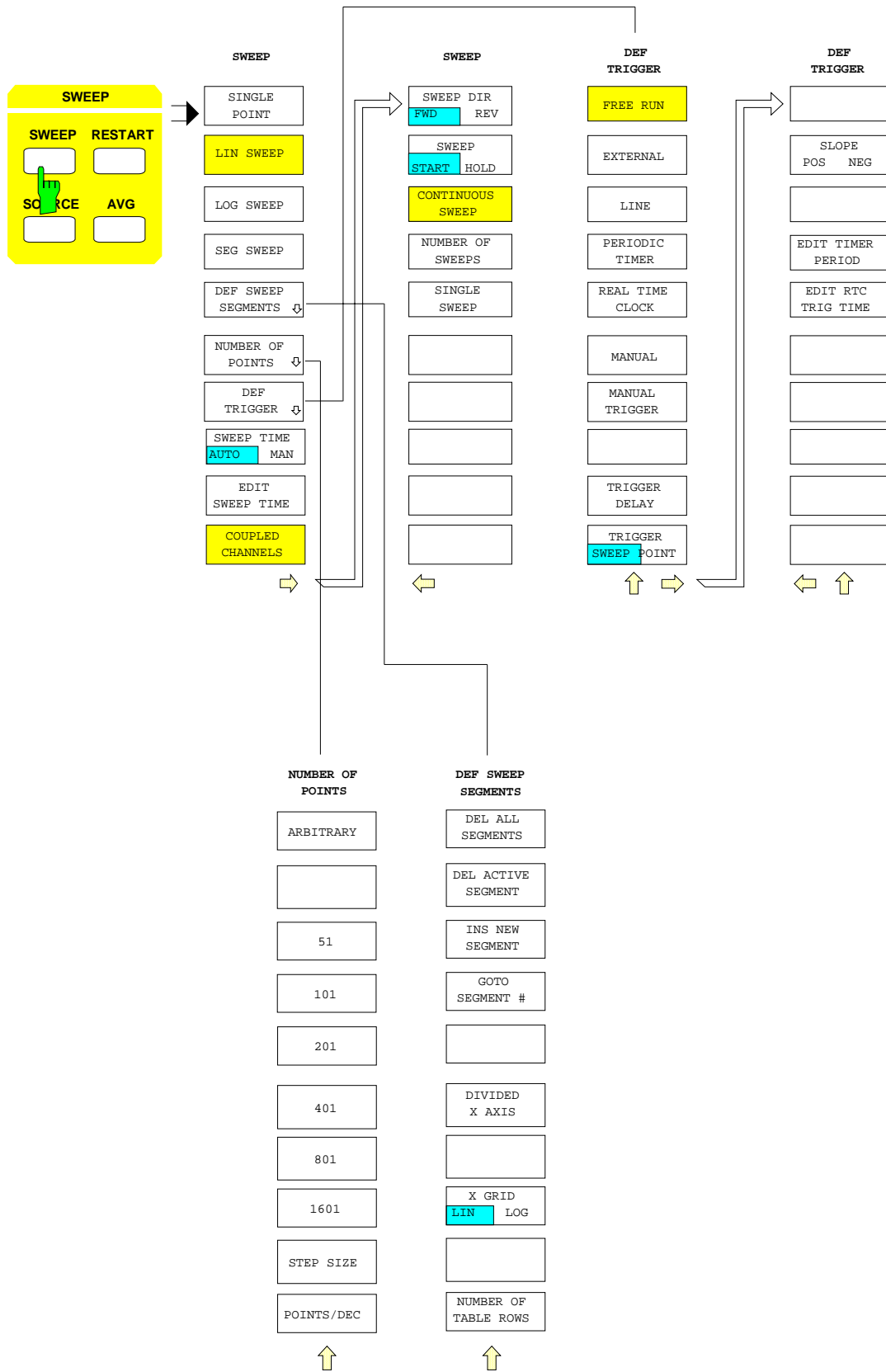


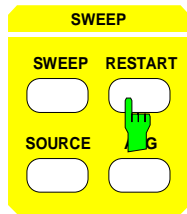


2.2.4 USER Key

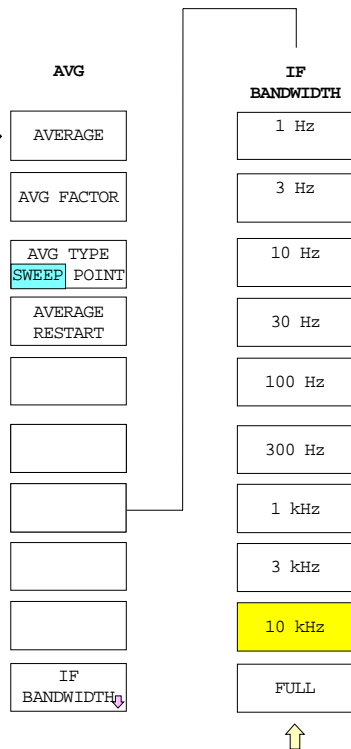
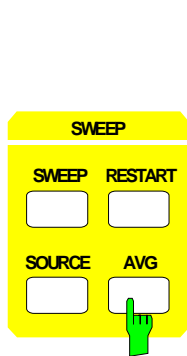
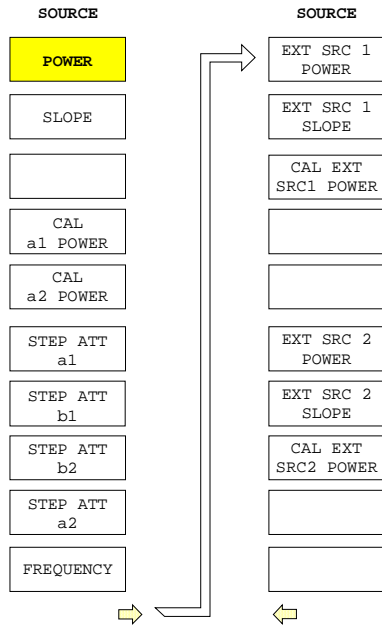
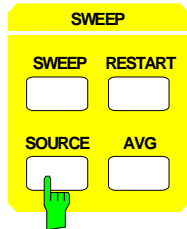


2.2.5 SWEEP Key Group

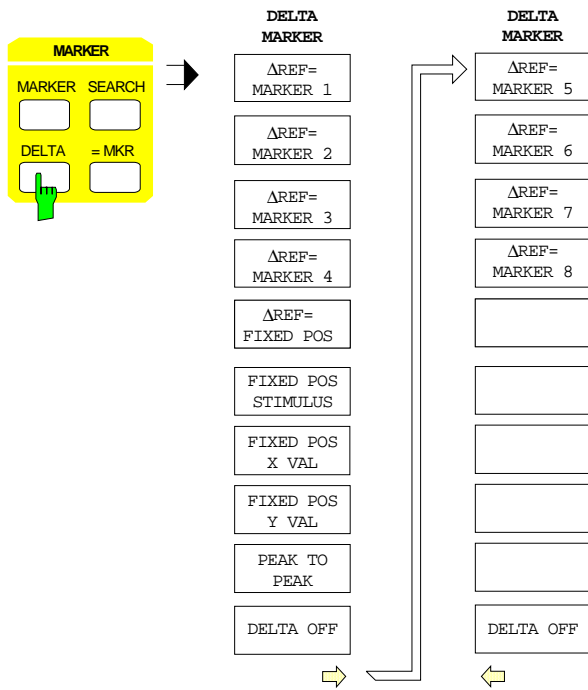
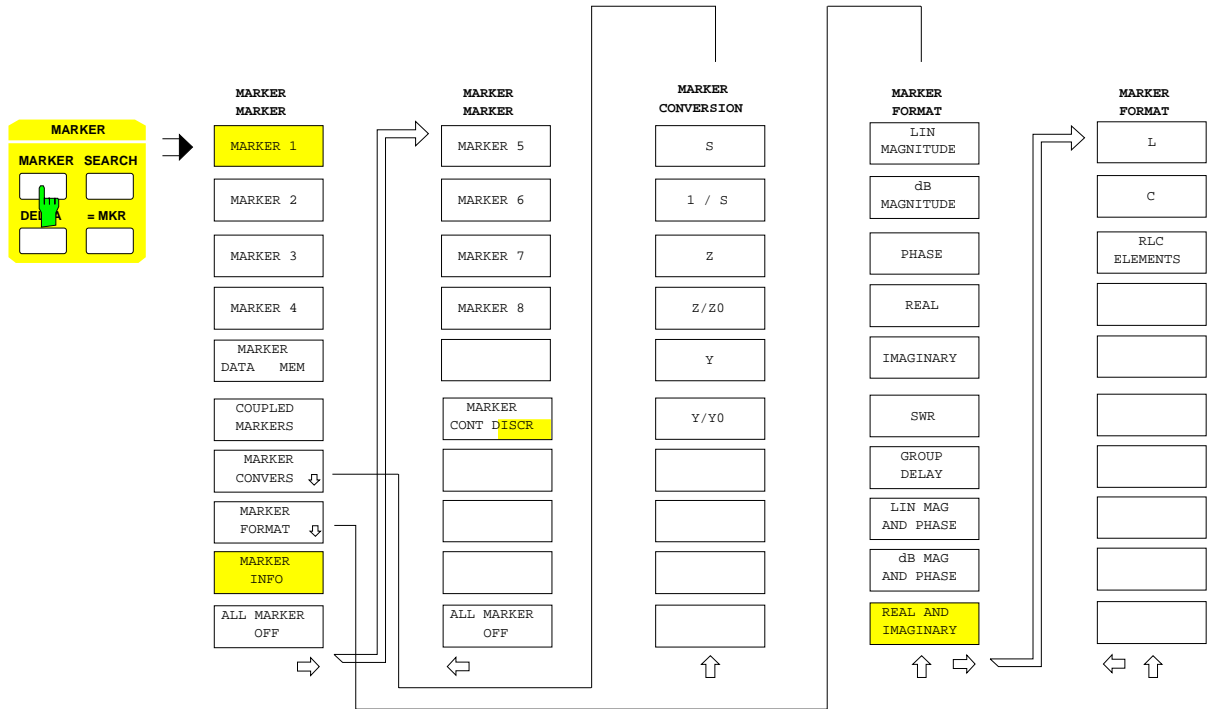


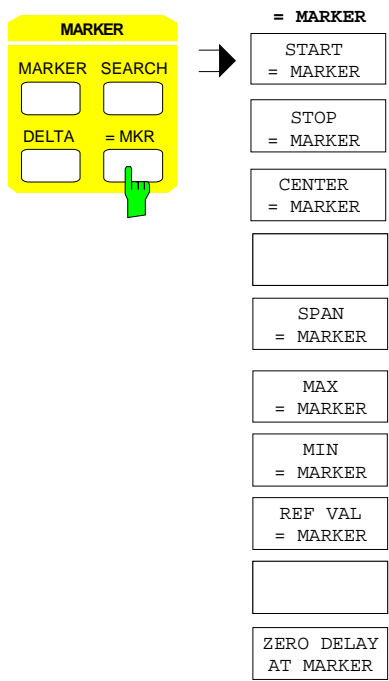
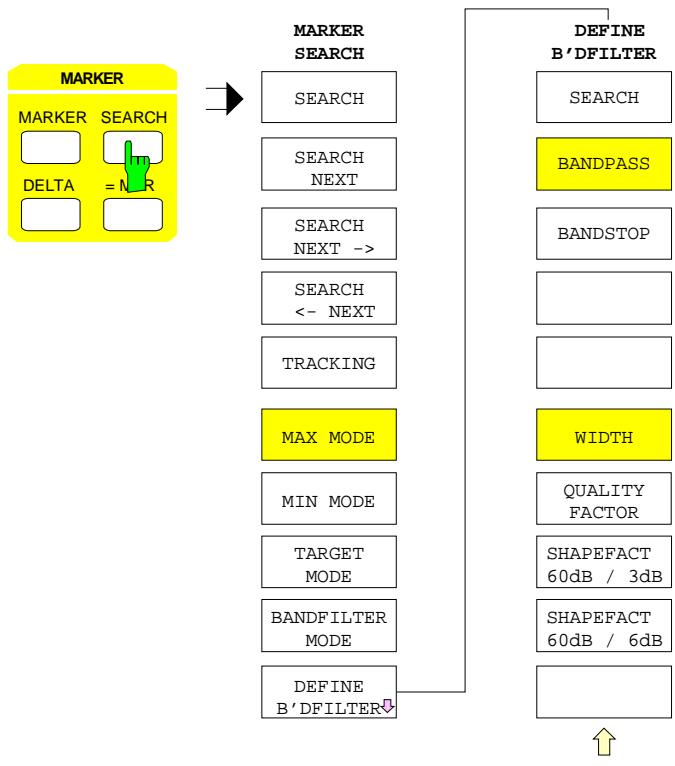


This key has no softkey menu assigned.

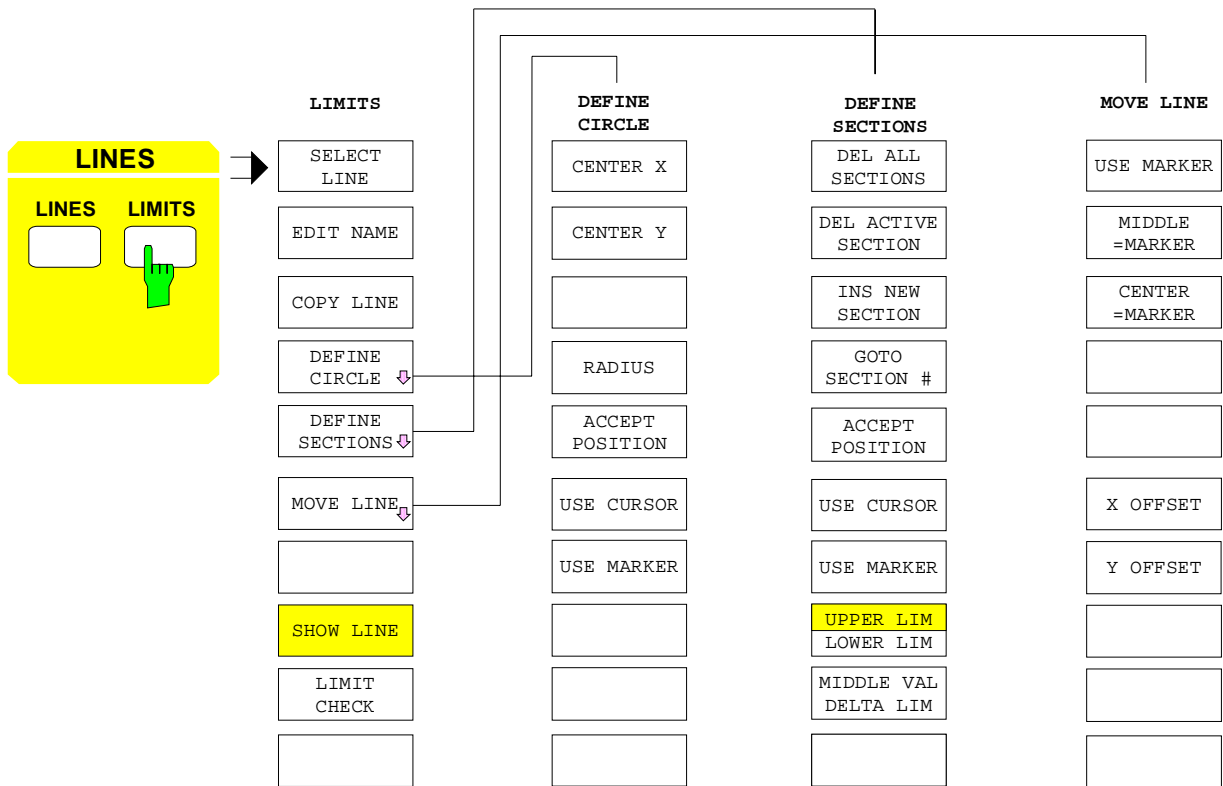
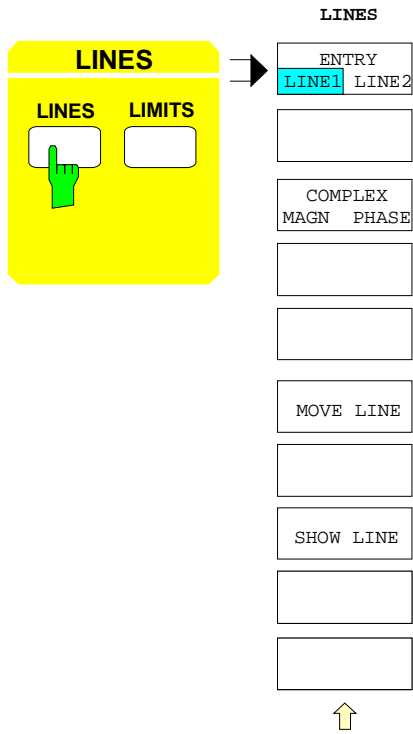


2.2.6 MARKER Key Group

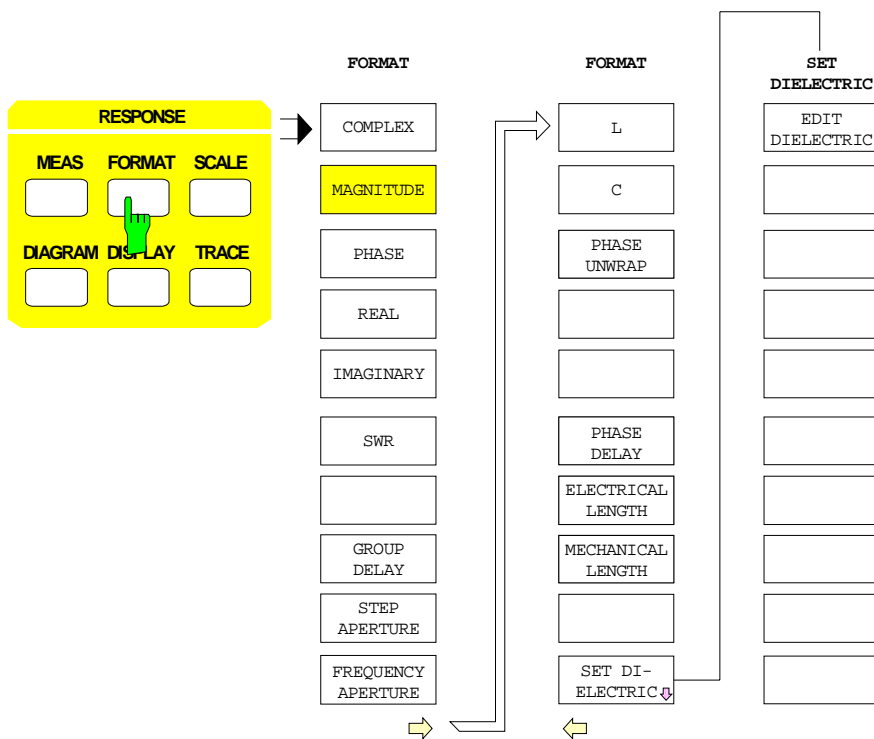
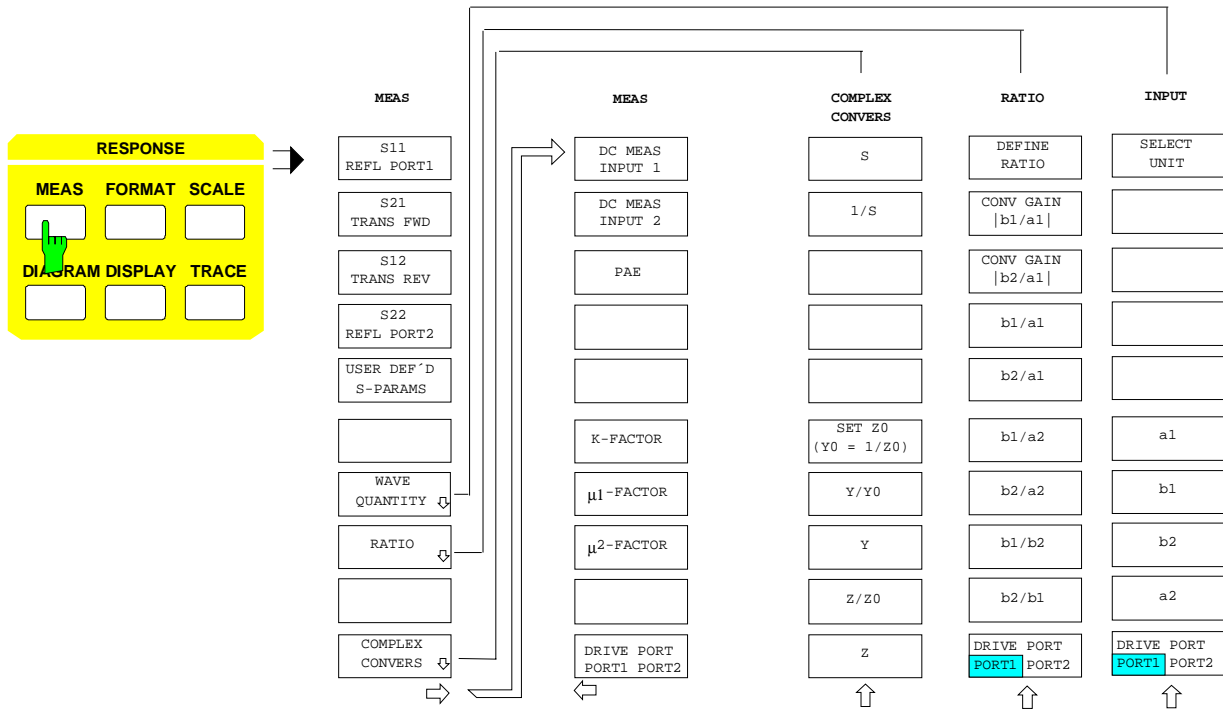


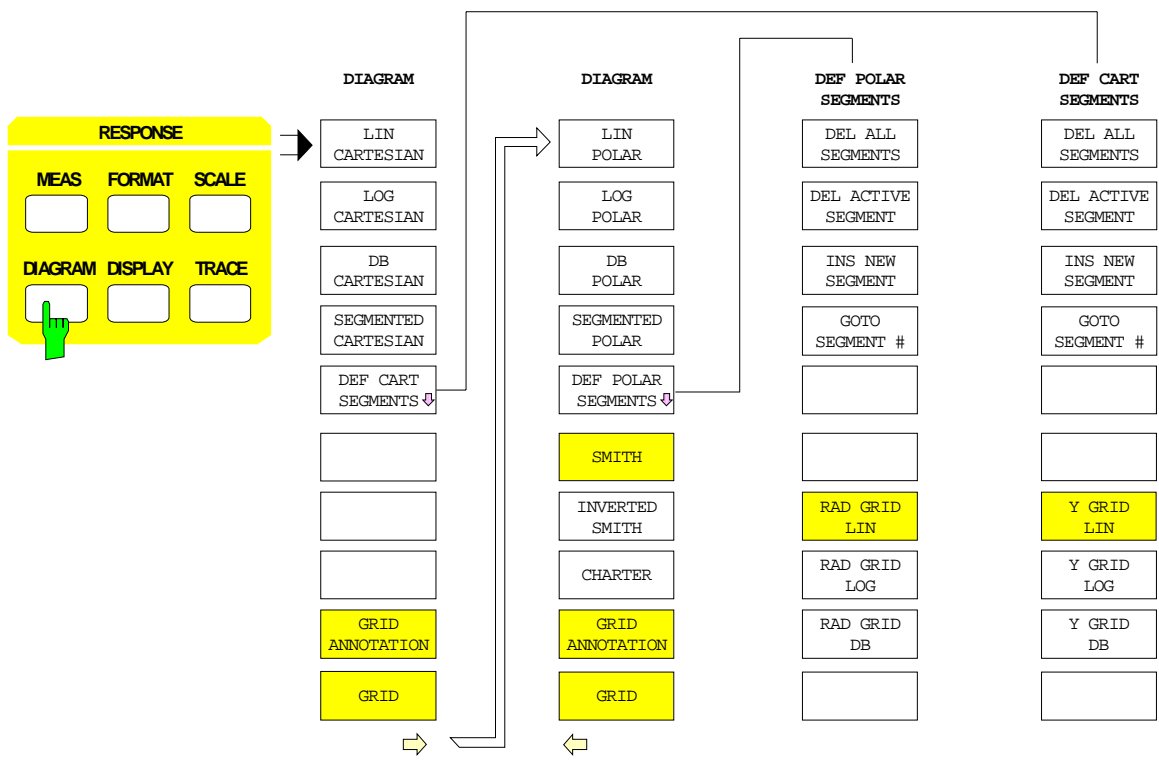
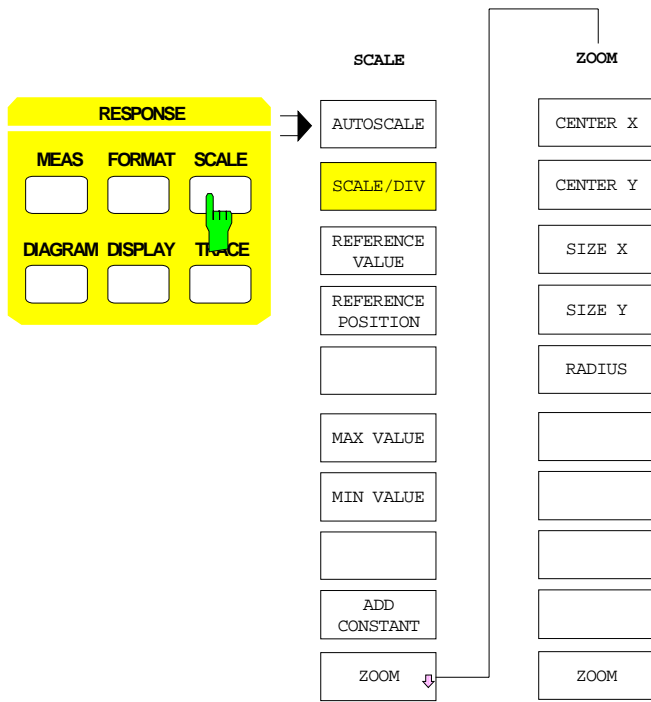


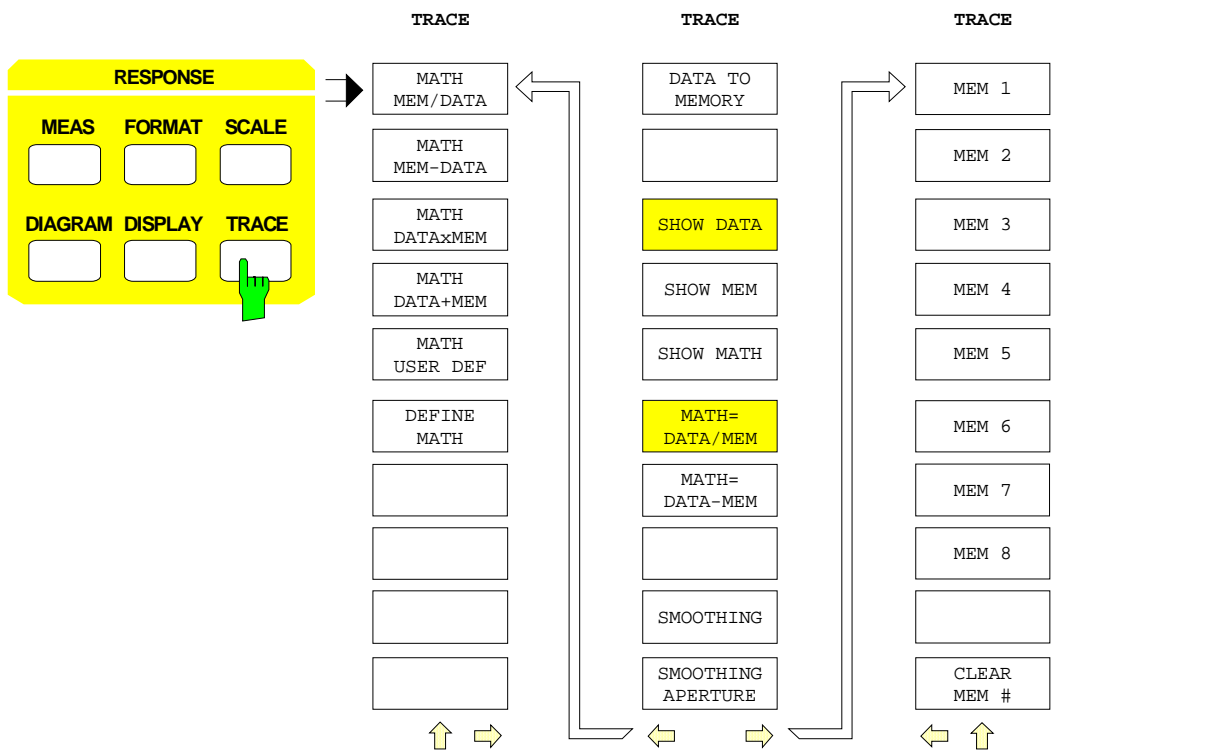
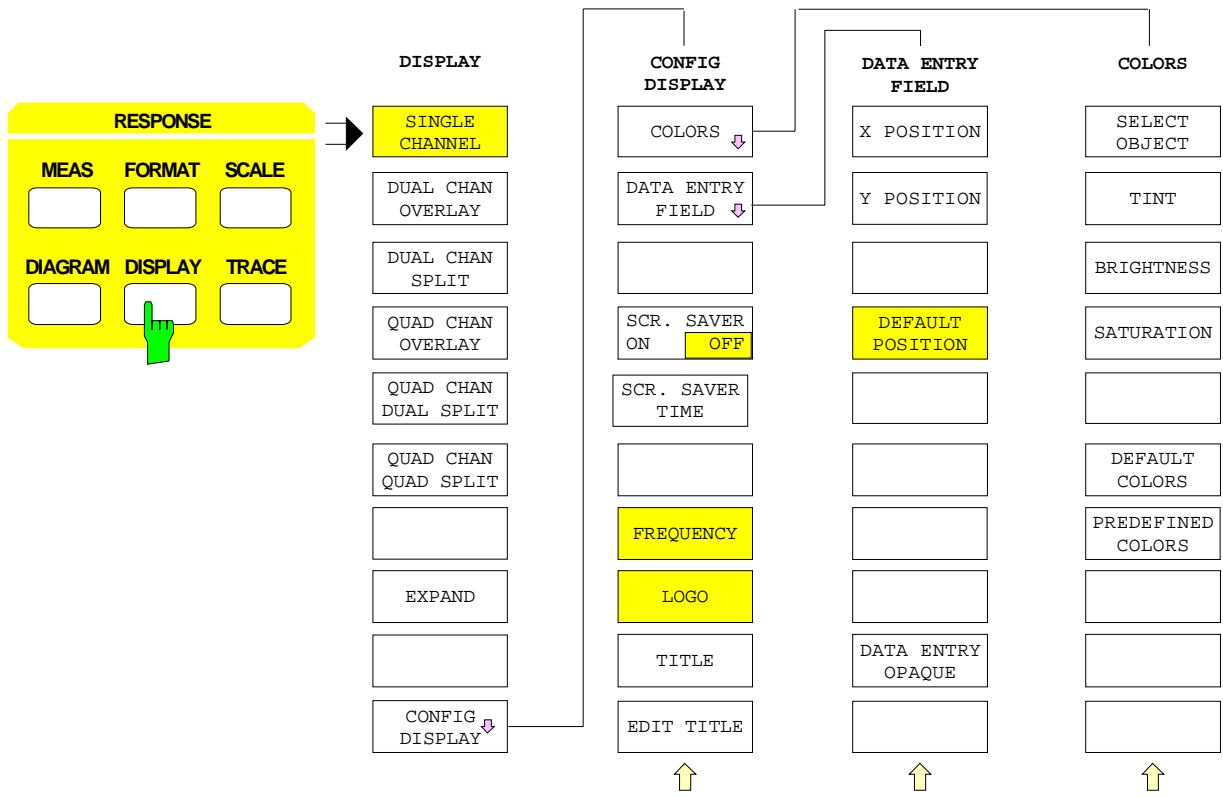
2.2.7 LINES Key Group



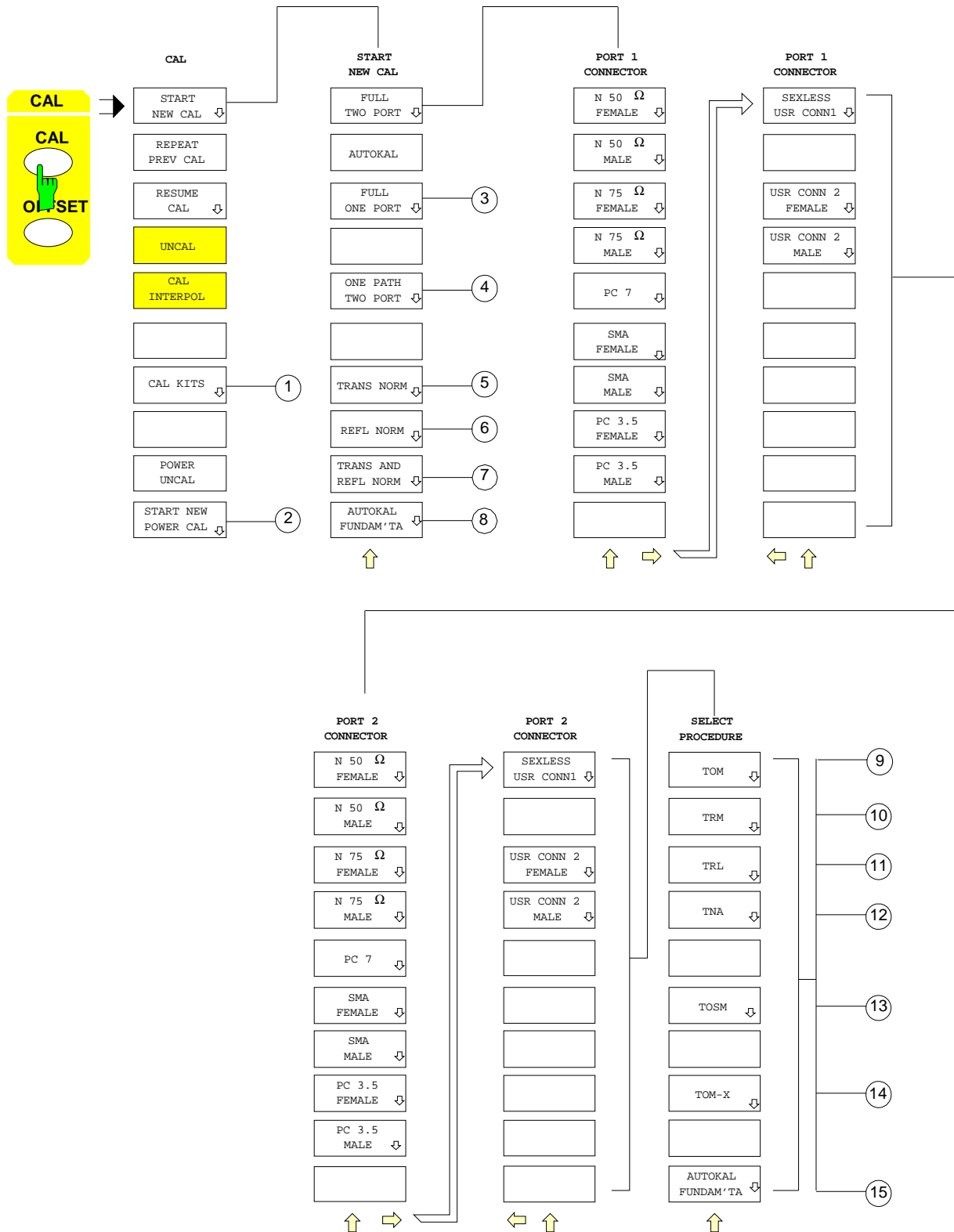
2.2.8 RESPONSE Key Group

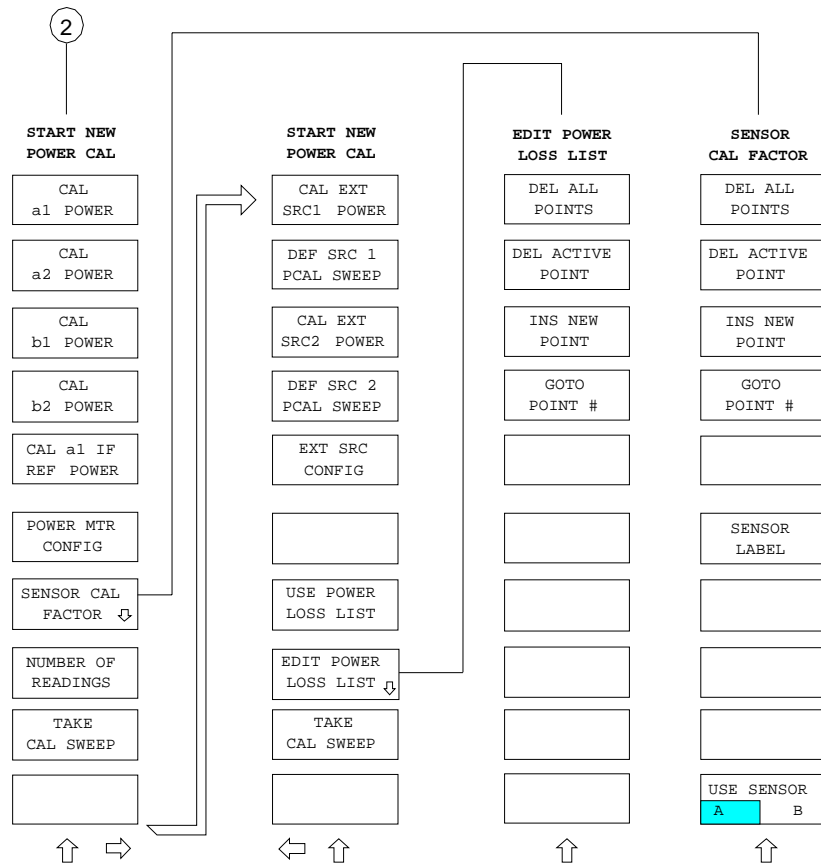
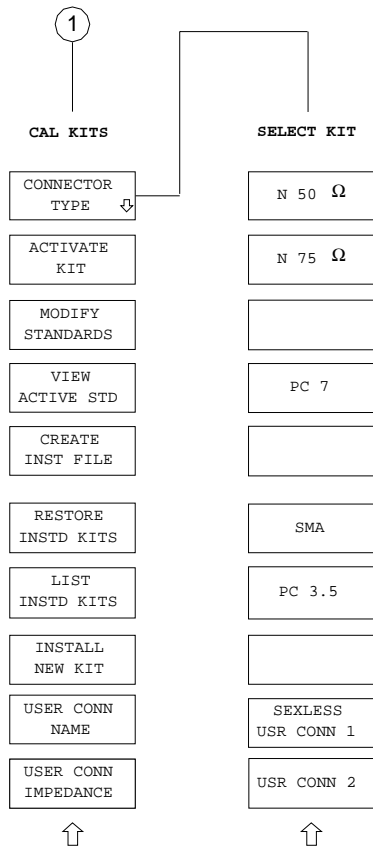


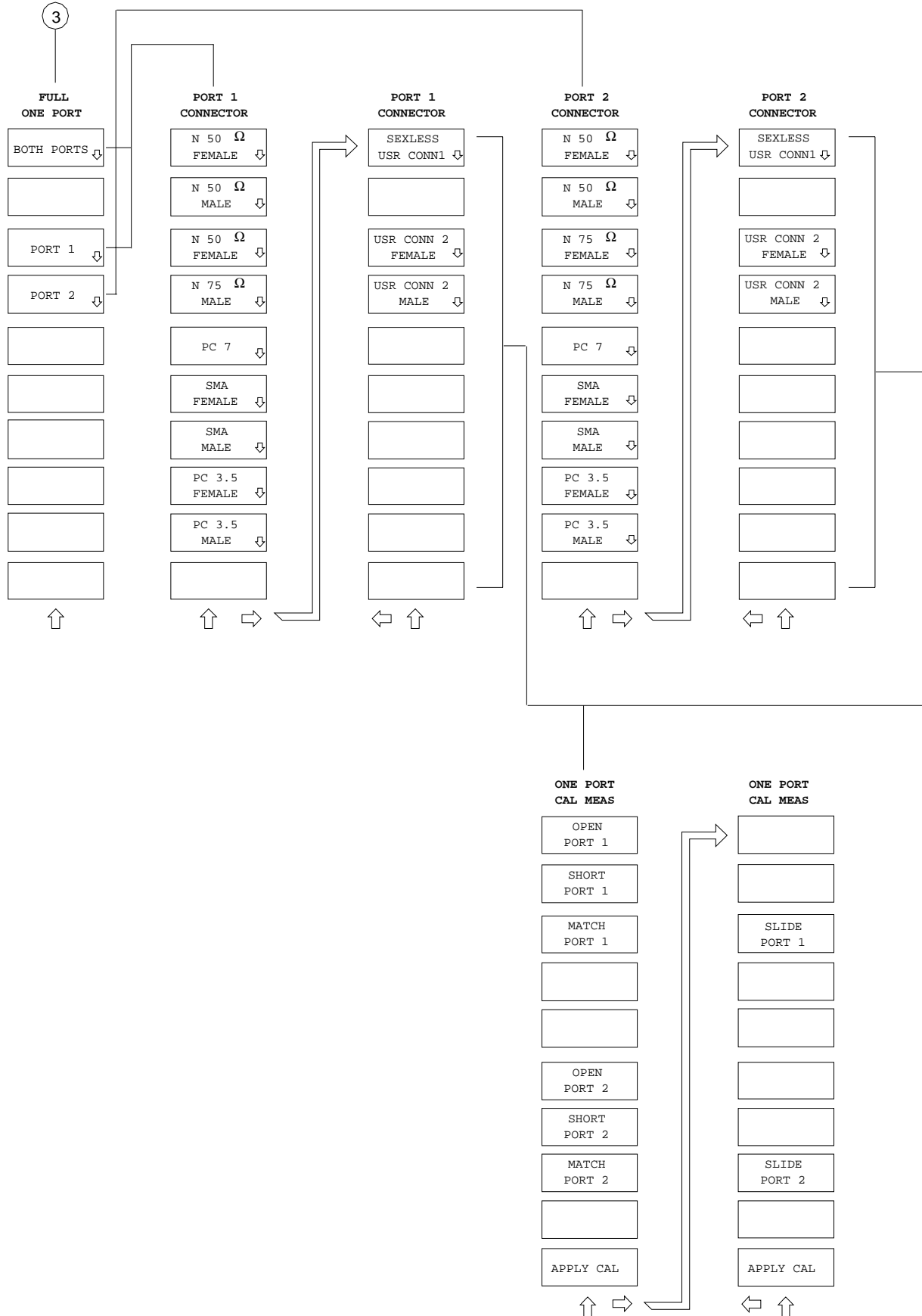


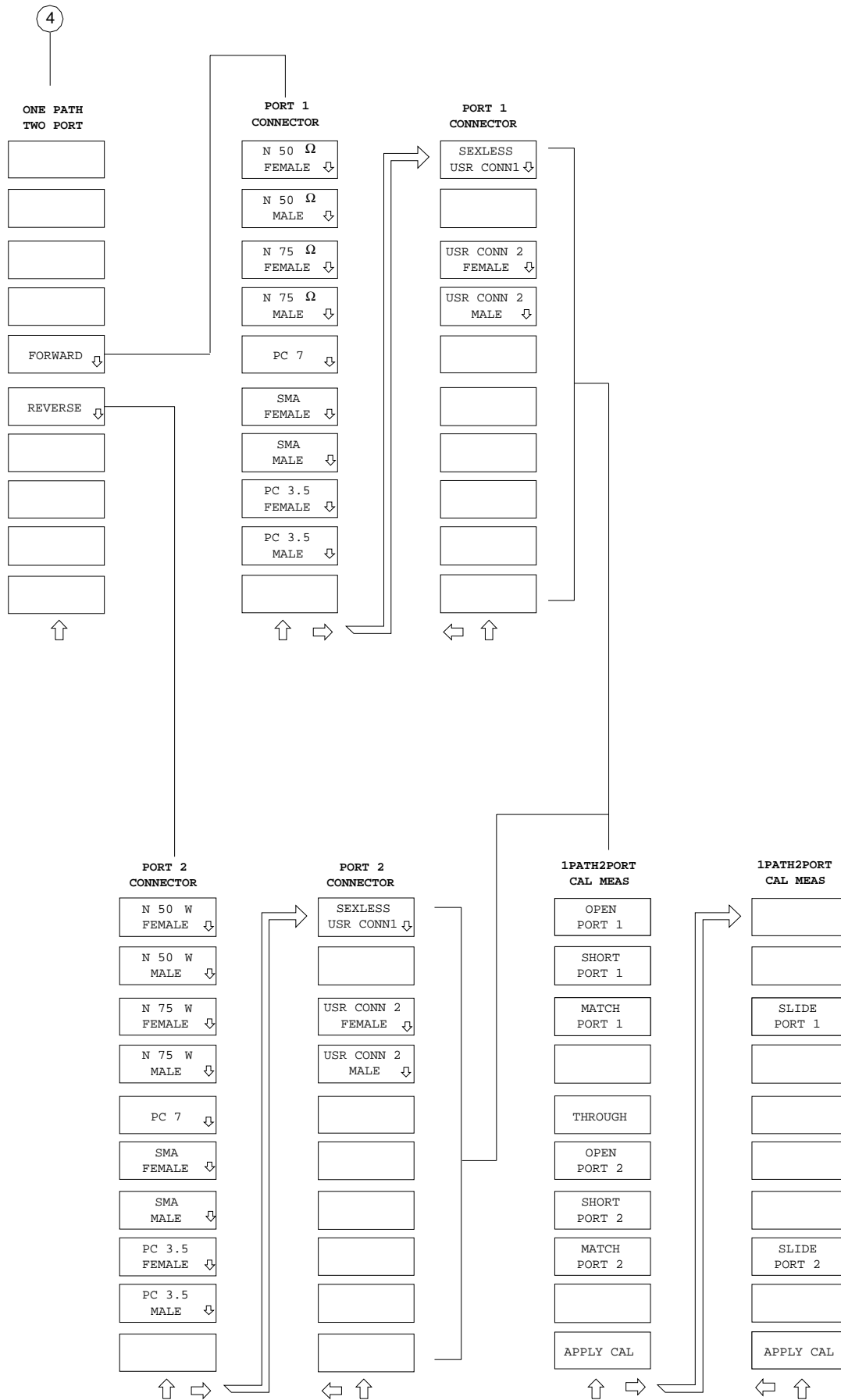


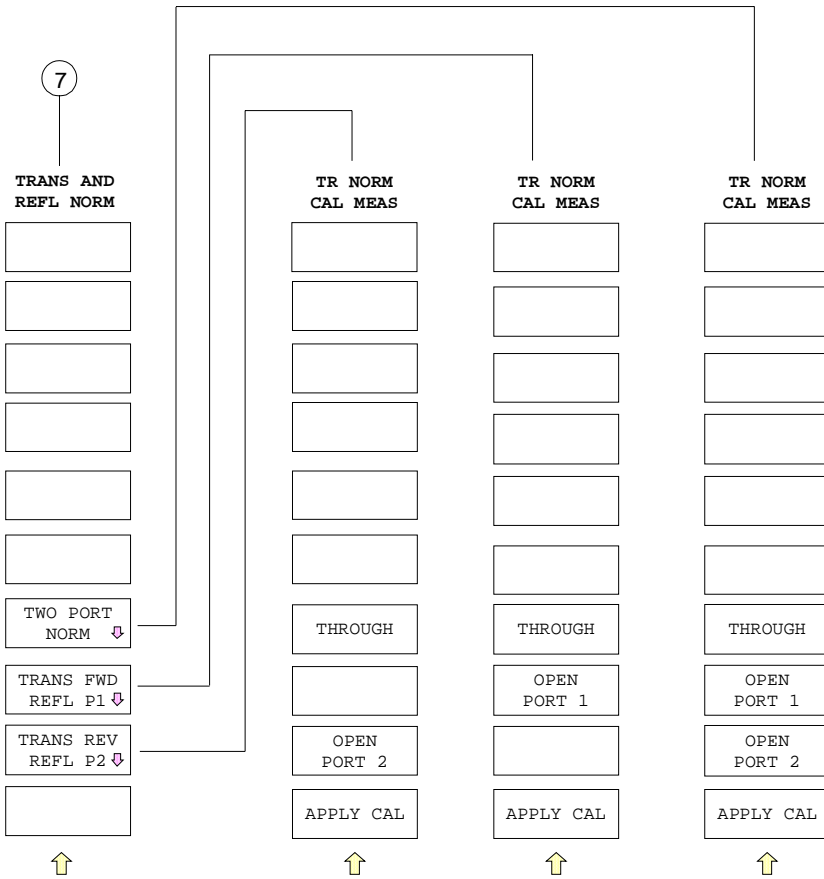
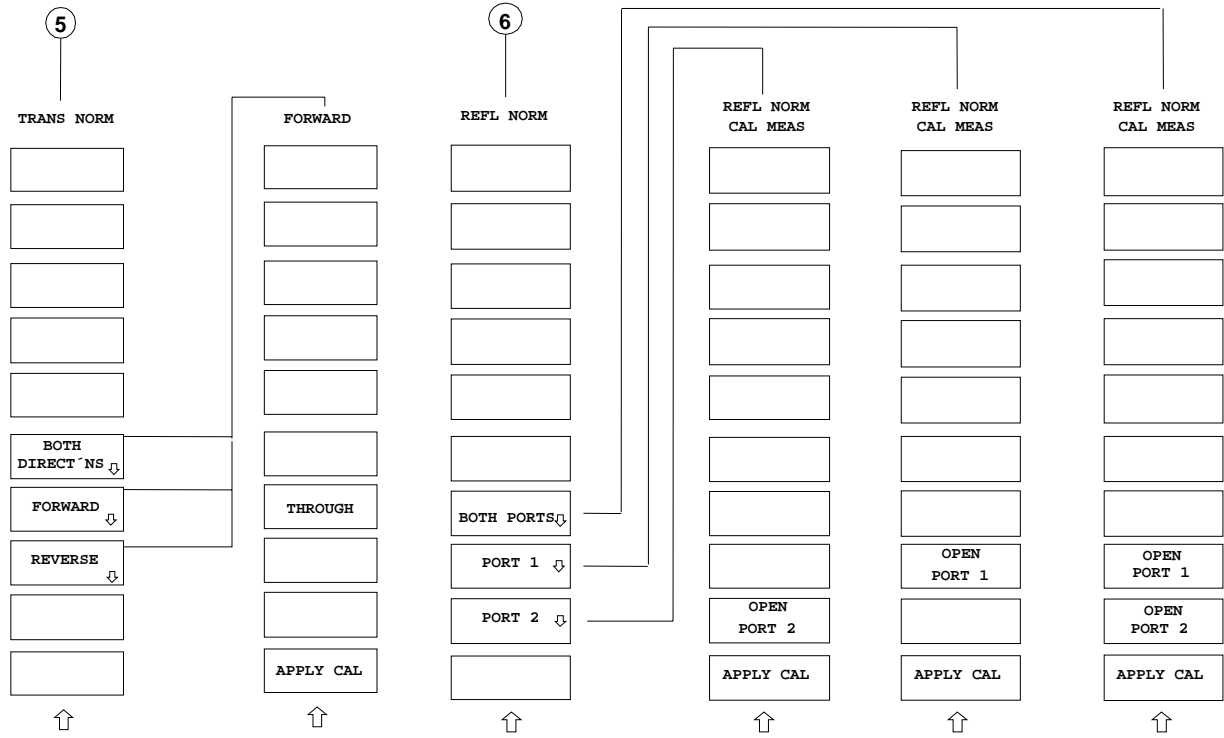
2.2.9 CAL Key Group

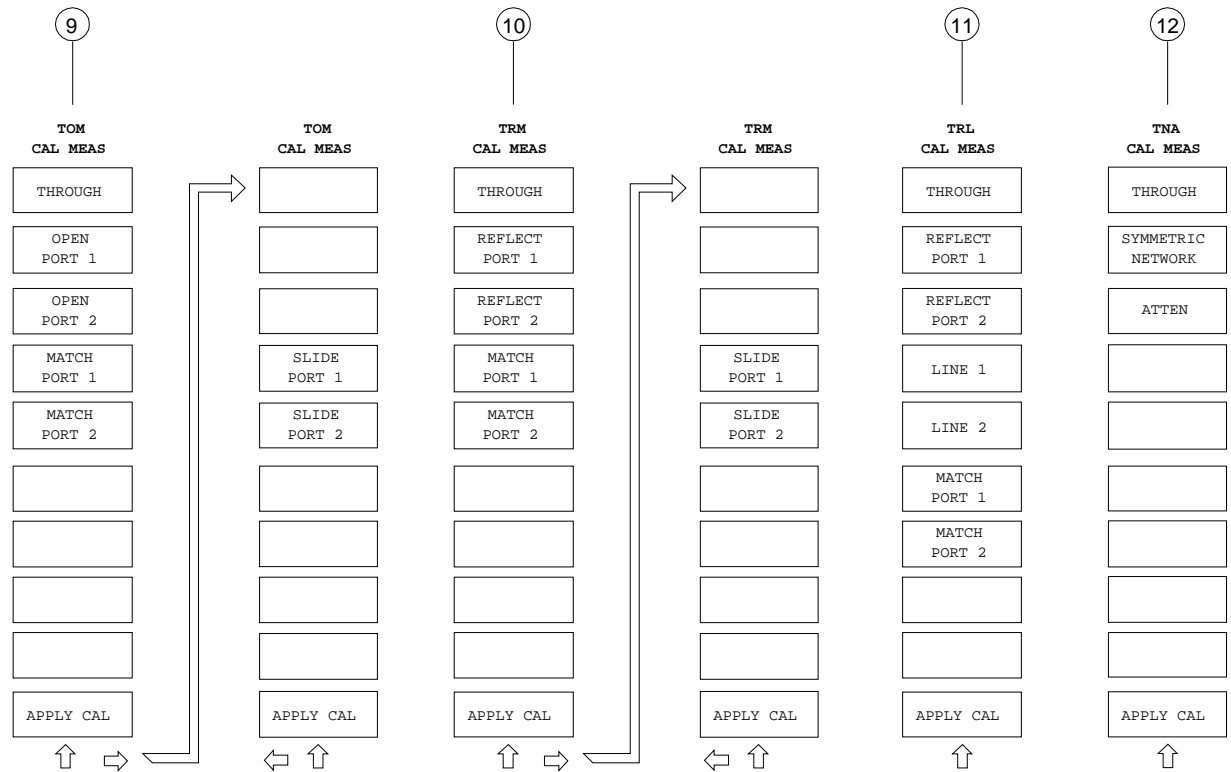
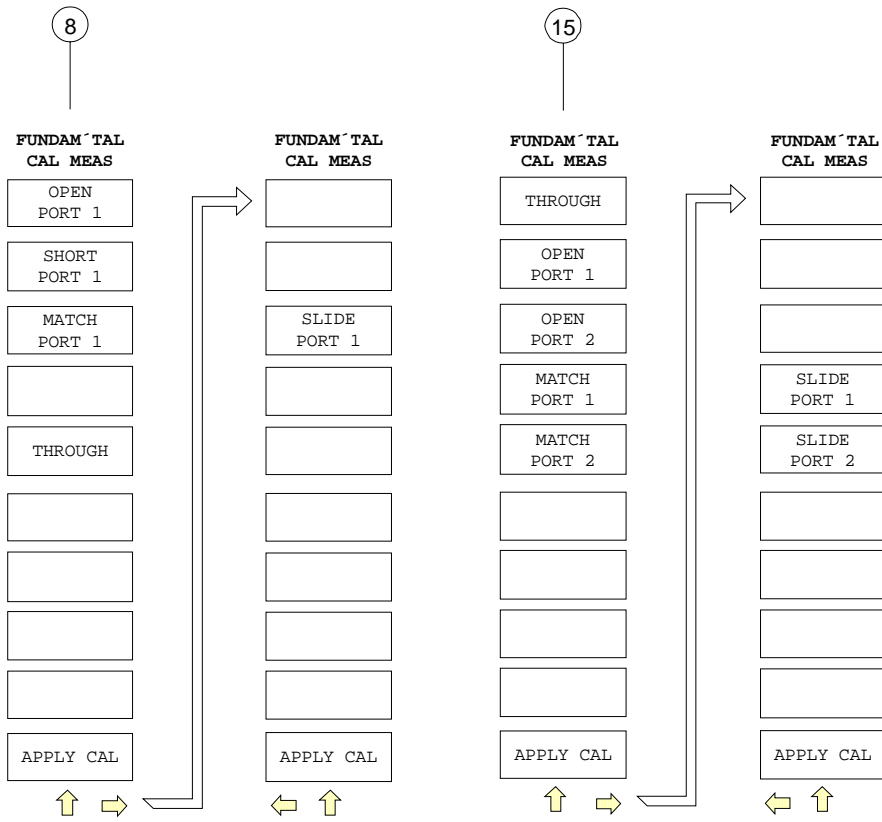






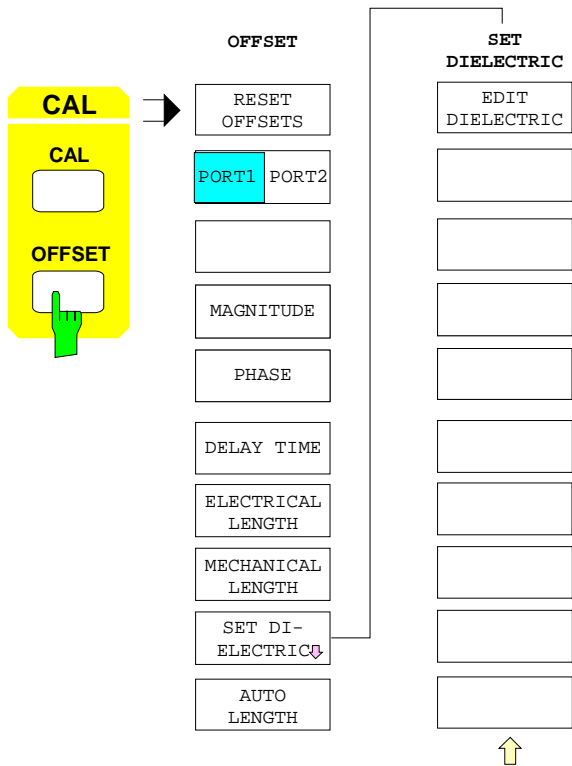
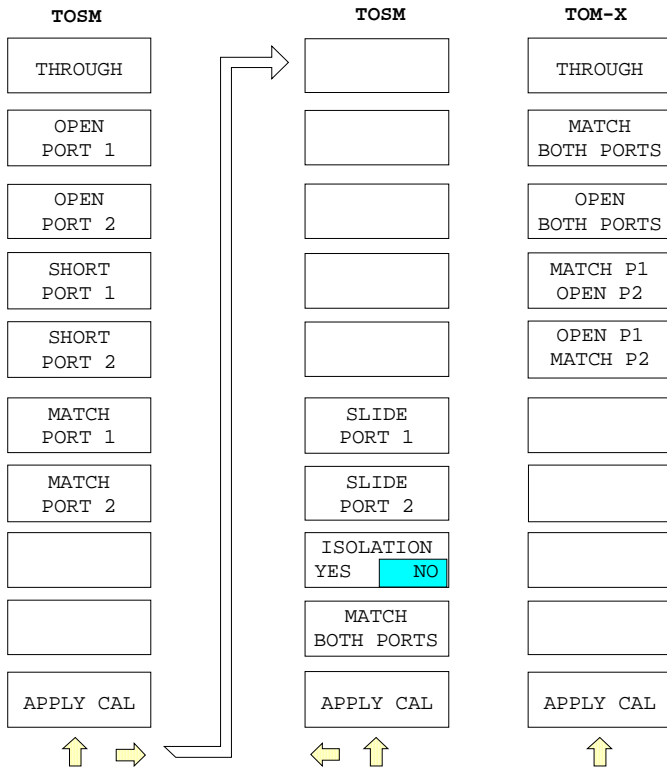






13

14



2.3 Basic Steps of Operation

Manual operation of the network analyzer is by means of keys and softkey menus. Device and test parameters can either be set directly via softkeys with switching function or by entering values into the fields or tables. If required, windows can be superimposed on the screen.

After switching on the instrument the setting of the measurement active prior to the last switch-off is restored (exception: another instrument configuration has been selected via *AUTO RECALL* in the *MEMORY RECALL* menu). Measurement results and settings of device parameters are displayed on the screen.

2.3.1 Screen

The screen informs continuously on the results and parameters of the selected measuring functions. The display of test results and the softkey labelling depend on the selected measurement function.

The test results are output in up to four channels that can be displayed at the same time. Different types of diagrams (Cartesian diagrams with linear and/or logarithmic axis division and various circle diagrams such as polar diagrams, Smith charts, inverted Smith charts and charter diagrams) can be selected in each display channel. Moreover, the channels can be arranged in different ways on the screen. The measuring diagrams of 1 to 4 channels can be displayed overlaid or separately, the stimulus parameters of the individual channels can be coupled or decoupled.

The general layout of the screen is explained in Fig. 2-12 using the display of a Cartesian diagram as an example.

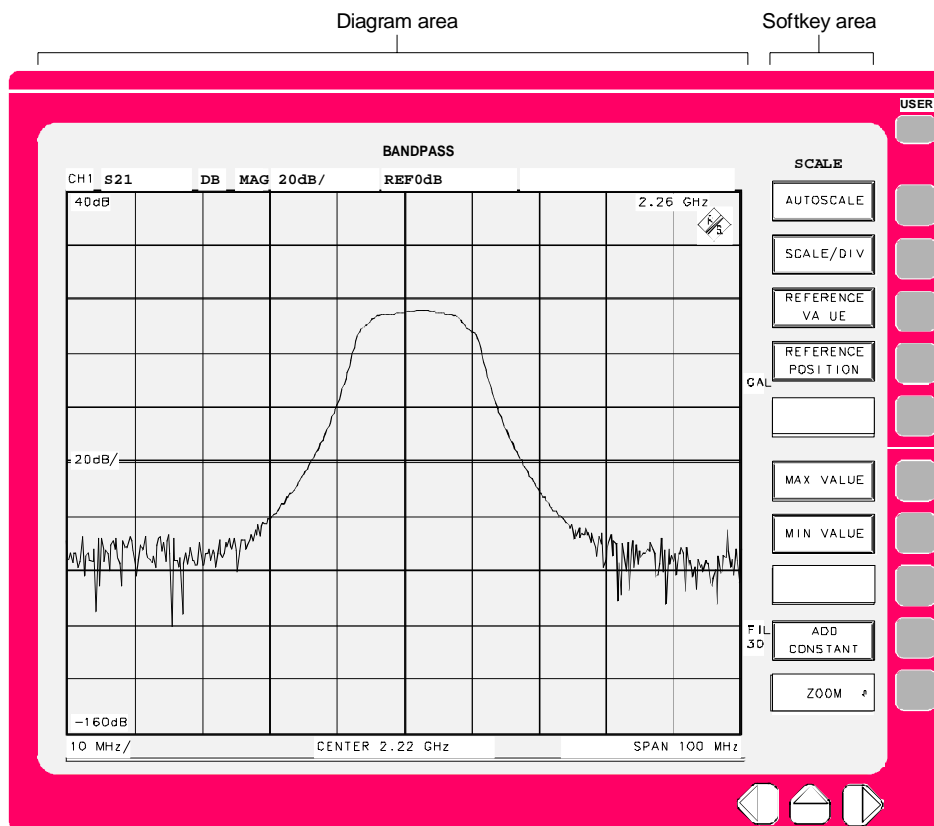


Fig. 2-12 General setup of the screen

The screen is subdivided into two areas:

Diagram area This area contains the measuring diagrams and other measured-value information as well as the parameters and status information which are important for the analysis of the results. In addition, message fields, entry windows and tables are shown in this area.

Softkey area The instrument functions which can be selected via the softkeys are displayed in this area.

2.3.1.1 The Diagram Area

The general setup of the diagram area is illustrated in Fig. 2-13.

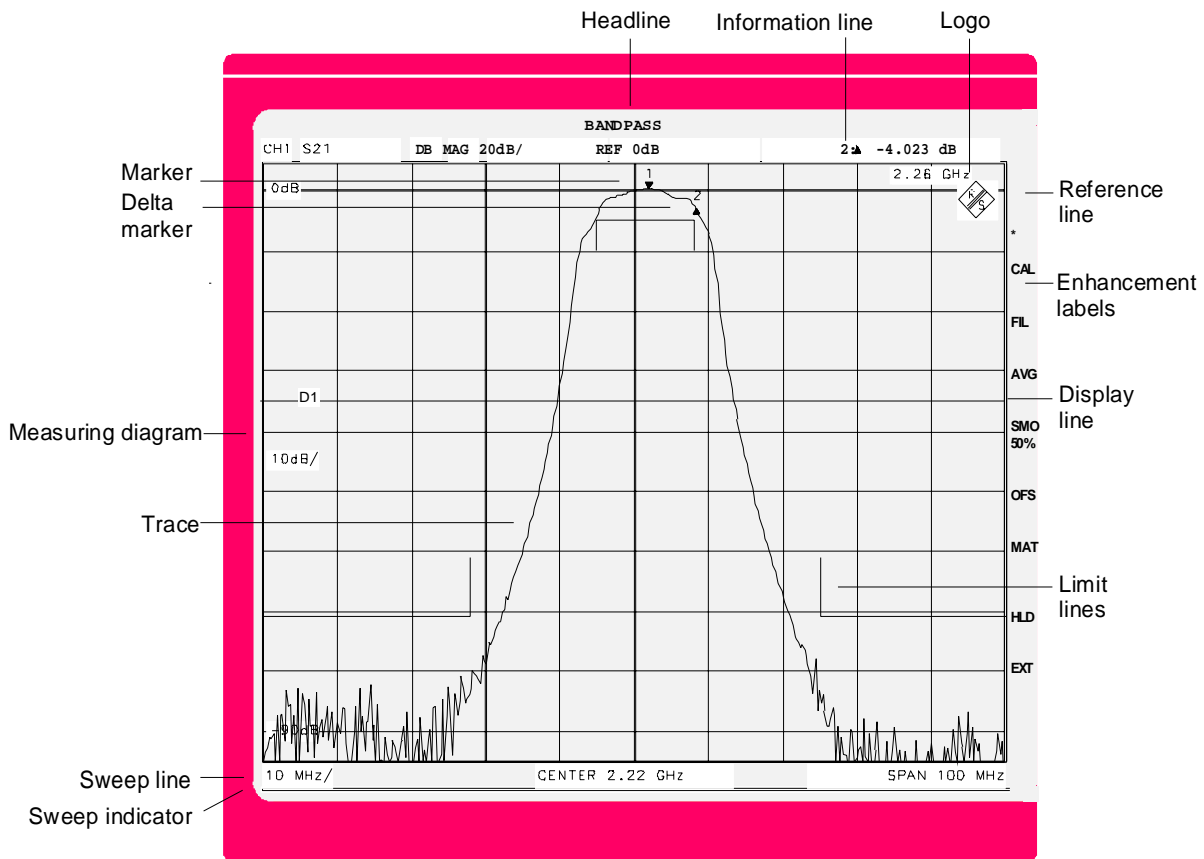


Fig. 2-13 Diagram area

Headline

Bandpass

The headline contains the user-defined labelling of a measurement. The title may be entered in the *RESPONSE DISPLAY-CONFIG DISPLAY* menu and displayed or removed. If the title is removed, this area of the screen is used for measuring diagrams.

Information line

CH2 S21 dB MAG 20 dB/ REF 0 dB σ_2 : -9.384 dB

The information line offers additional information on the diagram either in all or in a few of its eight fields. The following information is given from the left to the right:

CH1 Active channel.

CH1 to CH4 may be indicated. Channel-specific entries such as the selected test parameter or the scaling of the measuring diagram are with reference to the active channel.

S21 Selected test parameter in active channel.

The following test parameters are possible:

- S-parameters, e.g. S11, S21, S12 or S22
- Other ratios of wave quantities, e.g. b_1/a_1 , b_2/a_1 , b_2/Pa_1 (conversion gain)
- Wave quantities, eg a_1 , a_2 , b_1 , b_2
- absolute or normalized two-port Z or Y parameters such as Z11, Y11, Z_{11}/Z_0 , Y_{11}/Y_0
- DC voltage test inputs and derived quantities, eg DC1, DC2, PAE
- Stability factors, eg K, μ_1 , μ_2

If required, this field additionally indicates, whether a stored trace ('Mem Trace' or 'Math Trace', see below) is displayed in addition to the currently displayed trace. In these cases, xM is added to the entry in the parameter field. M is the abbreviation for 'Mem Trace'. The variable x indicates the kind of link between the data trace and the stored trace:

- & Simultaneous display of 'DataTrace' and 'Mem Trace'.
- + Display of the sum of 'DataTrace' and 'Mem Trace'.
- Display of the difference of 'DataTrace' and 'Mem Trace'.
- * Display of the product of 'DataTrace' minus 'Mem Trace'.
- / Display of the ratio of 'DataTrace' and 'Mem Trace'.
- # Display of a user-defined link of 'DataTrace' and one or more 'Mem Traces'.

Z/Z0 Conversion selected in active channel (in the example: none).

The conversion describes the calculation for converting the selected complex (vector) test parameter into another complex parameter:

- 1/S inverse scattering parameter
- Z impedance
- Z/Z0 normalized impedance
- Y admittance
- Y/Y0 normalized admittance

The S-parameters is often further processed without conversion. In this case, the information field remains empty.

Information line (continued)

dB Logarithmation in active channel

This field indicates whether the formatted parameter (see next field below) is displayed as linear parameter (LIN) or if a logarithmic value is calculated prior to display. In the case of logarithmic values the ordinate scaling can be selected to be logarithmic (LOG) or linear (dB).

Information line (continued)

MAG Formatting the test parameter in the active channel

Cartesian diagram:

The format display indicates whether the selected test parameter of the active channel is converted into a scalar component and if so in which one. The following components are possible:

| | |
|--------|---|
| MAG | magnitude |
| ϕ | phase |
| Re | real quantity |
| Im | imaginary quantity |
| SWR | standing wave ratio (special) |
| DLY | group delay |
| L | inductance (only for conversion of Y or Z) |
| C | capacitance (only for conversion of Y or Z) |
| CMP | compression point |
| SOI | 2nd-order intercept point |
| TOI | 3rd-order intercept point |

If a complex test parameter is displayed in a complex circle diagram, the field remains empty.

20 dB/ Scaling of measuring diagram in active channel

The values indicated in this and in the following field depend on the input mode for scaling.

With linear division of the ordinate or the radial axis, i.e. without logarithmation (LIN) or with logarithmation in dB, scaling can be entered via the SCALE / DIV, REFERENCE VALUE softkeys or REFERENCE POSITION. In the following, this is called SCALE / DIV entry. As an alternative, entry via MIN and MAX VALUE is also possible (in brief: MIN / MAX entry). Only the MIN / MAX entry is possible for logarithmic or segmented division as well as in the Smith chart or charter diagram.

Cartesian diagram:

With SCALE / DIV entry the value offset between two adjacent horizontal grid lines followed by a slash is displayed in the first scaling field. In case of MIN / MAX entry, the smallest ordinate value of the diagram is displayed and marked by a preceding downward arrow, eg $\downarrow -180^\circ$.

Polar diagram:


With SCALE / DIV entry the formatting field indicates the radial spacing between two adjacent scaling circles. A slash is inserted behind the numeric value and the unit.

If, with MIN / MAX entry, the amplitude value of the diagram center is different from zero (possible only with logarithmic or segmented polar diagrams), the value of MIN VALUE is displayed here. If the value is zero, the field remains empty.

Smith chart:

No entry, since the center value of the Smith chart is always zero.

Information line (continued)

| | |
|------------------------|--|
| REF 0 dB | Scaling of measuring diagram in active channel Cartesian diagram: In case of the SCALE / DIV entry, the ordinate value of the reference line (reference value) is output in the second scaling field behind REF, in case of MIN / MAX entry the highest ordinate value of the diagram is displayed after an upward arrow. Polar diagram: The radius of the reference circle is output behind REF for SCALE / DIV entry. For MIN / MAX entry the diagram radius with a preceding upward arrow is displayed. Smith chart: The radius of the diagram is output after an upward arrow. |
| σ_2 : -9.384 dB | Current measured value of the active marker or delta marker This information field remains empty when 4 windows are displayed simultaneously (QUAD CHANNEL QUAD SPLIT). The marker value is displayed in the diagram instead. |
| Logo |  (covered by the marker info list in the example) A company's logo (default: R&S logo) can be inserted into or removed from the display and printout via the <i>RESPONSE-DISPLAY-CONFIG DISPLAY</i> menu. |

Enhancement labels

Enhancement labels indicate important instrument settings, which essentially influence the measurement and which are not immediately obvious when viewing the measured values.

| | |
|------------|---|
| MAC | A macro is recorded (<i>USER – DEFINE MACRO – RECORD</i> function in ON position). |
| GAT | A gate is active during measurement in the time domain (<i>SYSTEM MODE – TIME DOMAIN – TIME GATE</i> function is active). |
| WND | During transformation to the time domain the measurement data in the frequency range are weighted with a window function (<i>SYSTEM MODE – TIME DOMAIN – DEF TRANSF TYPE – NO PROFILING</i> function not active). |
| EXT | Receiver inputs INPUT b1 and INPUT b2 are active (ZVRx, ZVCx: <i>SYSTEM MODE – EXTERNAL</i> mode, only with option ZVR-B25) |
| H=2 | Receive frequency is the second harmonic of generator signal (mode: <i>SYSTEM MODE-FREQ CONVERS-SECOND HARMONIC</i>). |
| H=3 | (alternatively) The receive frequency is the third harmonic of the generator signal (mode: <i>SYSTEM MODE-FREQ CONVERS-THIRD HARMONIC</i>). |
| MIX | (alternatively) The mixer measurement is switched on (mode <i>SYSTEM MODE-FREQ CONVERS-MIXER MEAS</i>). |

Enhancement labels (continued)

| | |
|--|--|
| ARB | (alternatively) The arbitrary frequency conversion is activated (mode: <i>SYSTEM MODE-FREQ CONVERS-ARBITRARY</i>). |
| CMP | The compression point measurement is activated (mode: <i>SYSTEM MODE-COMP SOI TOI-COMPRESS POINT</i>). |
| SOI | (alternatively) The measurement of the second-order intercept point is activated. (mode: <i>SYSTEM MODE - COMP SOI TOI - SOI</i>). |
| TOI | (alternatively) The measurement of the third-order intercept point is activated (mode: <i>SYSTEM MODE-COMP SOI TOI-TOI</i>). |
| FST | The FAST MODE is active (mode: <i>SYSTEM MODE-FAST MODE</i>). |
| CAL | The system error correction is activated (<i>CAL CAL - UNCAL</i> function not active). |
| CAI | (alternatively) The system error correction is activated and system error correction data are interpolated (<i>CAL CAL-INTERPOL</i> function active). |
| CA? | (alternatively) The system error correction is activated (function <i>CAL CAL - UNCAL</i> not active), but the generator level does not correspond with the level of the calibration (does not apply to ZVK, ZVM with <i>FULL ONE PORT</i> or <i>Txx</i> calibration and change of attenuation of generator step attenuator). |
| ADD | A constant is added to the scalar measurement value or to the magnitude of the complex measured value (function <i>RESPONSE - SCALE - ADD CONSTANT</i> active). |
| OFS | The measurement with length, amplitude or phase offset $\neq 0$ is active (entry via <i>CAL OFFSET</i>). |
| PC 1/a1I a2/a2I b1/b2/b12 E1/E2/E12 | Power correction is activated. Beneath PC, a maximum of 4 lines indicate the wave quantities which are subject to power correction (<i>CAL CAL - POWER UNCAL</i> function is not active). The display a1I appears when only one receiver level correction is active for wave quantity a_1 ; accordingly for a_2 . E1, E2 or E12 indicates that valid power correction data is available for one or both external signal generators. However, the display goes off when the associated generator is being operated in a range which is not, or not completely, covered by the correction data. |
| PCI a1/a1I a2/a2I b1/b2/b12 E1/E2/E12 | (alternatively) The power correction is switched on with interpolation performed versus frequency. A frequency interpolation is not displayed for external generator. |

PCO
a1/a1I
a2/a2I
b1/b2/b12
E1/E2/E12

(alternatively) The power correction with offset is switched on, ie, the rated value of a generator level calibration was modified subsequent to calibration. A calibration offset is not displayed for external generators.

Enhancement labels (continued)

| | |
|---|---|
| PC? 1/a1I a2/a2I b1/b2/b12 E1/E2/E12 | (alternatively) The level correction is switched on, but the rated value of the level was not attained at all test points during the calibration, or the level offset is so large that the setting range of a generator is exceeded. |
| CPL | The display channels are coupled (<i>SWEEP SWEEP-COUPLED CHANNELS</i> function is active). |
| HLD | The sweep is interrupted (<i>SWEEP SWEEP-CONT HOLD</i> function is in <i>HOLD</i> position). |
| TRG EXT | The measurement is triggered, ie the trigger source is indicated in the line below. Possible trigger sources are (see Section 2.10.1.3): EXT external source LIN zero crossing of the ac voltage TIM internal clock source with settable period length RTC real-time clock MAN manual trigger (<i>SWEEP-SWEEP-DEF TRIGGER – FREEE RUN</i> is not active) |
| AVG 300 | Averaging is switched on. Beneath AVG, the averaging factor (<i>SWEEP AVG - AVG FACTOR</i> function) is indicated (<i>SWEEP AVG-AVERAGE</i> function is active). |
| FIL 10k | Beneath FIL, the IF bandwidth of the receiver is indicated (<i>SWEEP AVG- IF BANDWIDTH</i> function). |
| SMO 20% | The trace is smoothed. Beneath SMO, the smoothing aperture (<i>RESPONSE TRACE-SMOOTHING APERTURE</i> function) is indicated (<i>RESPONSE TRACE-SMOOTHING</i> function is active). |
| MAT | A mathematical linkage is switched on (<i>RESPONSE TRACE-SHOW MATH</i> function is active). |



With mouse control, a double click on one of the fields causes switchover to the softkey menu which allows for modification of the respective setting.

| | |
|-----------------------|--|
| Reference line | The reference line/circle marks the location of the reference value for each channel. With MIN/MAX entry, with segmented axis as well as with Smith charts and charter diagrams there is no reference line/circle. In Cartesian diagrams, the reference line is marked by a triangle. The reference value is output after this triangle. |
| Display lines | A display line is an auxiliary line that can be shifted. It is a like a ruler. Display lines facilitate the analysis of the trace. Horizontal display lines with associated current ordinate value are provided in Cartesian diagrams. The display lines are radial or circular in circle diagrams (see Section 2.12.1, Display Lines). |
| Limit lines | A limit line is a special help line that can be configured by the user. An automatic check is made whether the limit line is violated for the current trace (see Section 2.12.2, Limit Lines). |

Sweep indicator

The sweep indicator is a progress bar at the lower edge of the screen showing the current state of the sweep. This is particularly useful for slow sweeps or for the representation of measured values in circle diagrams.

Independent of the number of displayed channels there is one sweep indicator only. If several display channels are measured uncoupled, ie one after the other, the corresponding sweep indicator is displayed for each channel. The colour of the sweep indicator depends on the colour of the trace to be measured. For coupled channels, the sweep indicator has the colour of the active channel.

The sweep indicator can be displayed or removed in the *RESPONSE DISPLAY-CONFIG DISPLAY* menu. With zoomed diagram display, the sweep indicator (bar) continues to show the complete sweep between start and stop frequency instead of only the section of the sweep which is inside the zoom range.

The sweep indicator operates like a progress bar, ie a coloured bar is shown from left to right according to the current sweep position. The sweep indicator is not labelled.

Sweep line

10 MHz/

CENTER 2.23 GHz

SPAN 100 MHz

The sweep line indicates the limits of the sweep range. It is indicated below the diagram for all diagram types. Three types of indication are possible:

- Indication of the START and STOP values. The increment between two grid lines is shown in the center.
- Indication of the CENTER and SPAN values. The step size between two grid lines is shown at the beginning of the line (left).
- Indication of the value of the sweep variable for SINGLE POINT measurement .

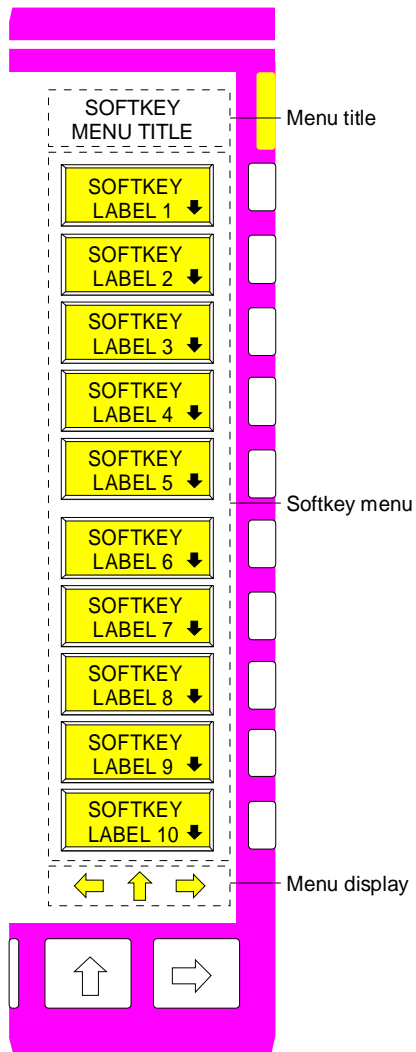
The readout of the increment between two grid lines is omitted in circle diagrams.

Note: *In the power sweep mode, the displayed sweep range applies to the test port that supplies the stimulus for the test parameter in the active display channel (for example PORT 1 for S_{11}). For the sweep range, any generator power calibration or attenuation of the generator step attenuators that may be active is taken into account.*

- Measuring diagram** The measuring diagram is displayed in the diagram area of the screen. Different types of diagram may be selected (see Section 2.14.4, *RESPONSE DIAGRAM* menu):
- Cartesian diagrams with linear and/or logarithmic scaling and
 - various circle diagrams such as
 - polar diagrams with linear or logarithmic radial scaling,
 - Smith charts,
 - inverted Smith charts and
 - charter diagrams.
- Within Cartesian diagrams, the spacing of horizontal lines (SCALE / DIV) is given in the middle (left). The top and bottom lines in the grid are labelled. Circle diagrams are not labelled – exception: Smith charts and charter diagrams. In the power sweep and time sweep modes, the CW frequency is indicated at the bottom left.
- Measuring curve** Three different types of traces can be displayed (see Section 2.14.6, *RESPONSE TRACE* menu):
- **Data Trace**
The Data Trace represents the current measured data.
 - **Memory Trace**
The Memory Trace is a stored data trace. The colour of the Memory Trace can be different from the colours of the data or Math Traces. It is, however, the same for all four display channels.
 - **Math Trace**
As an alternative to the Data Trace, the arithmetical linking of the Data Trace and the Memory Trace can be output. The Math Trace has the same colour as the Data Trace but is marked by the enhancement label MAT.
- Delta marker** In the delta mode, the difference between stimulus and response values of markers compared to a so-called reference marker is determined (see Section 2.3.4.2, Marker Info Lists, and Section 2.11.3, Delta Markers).
- Marker** Markers are used to read out measured values (see Section 2.3.4.2, Marker Info Lists, and Section 2.11.1, Marker).

2.3.1.2 The Softkey Area

The softkey area is subdivided into the menu title, the actual softkey menu and the menu display.



The menu title is displayed above the 10 softkeys.

The softkey labelling and function depends on the respective menu.

The softkeys call up submenus, open entry windows or make a 1-out-of-N selection (see Sections 2.3.4 and 2.3.5).

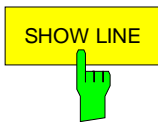
Softkeys are masked out if the functionality which they represent is not available. A distinction has to be made between two cases:

- If an instrument function is optional, and if this option is not fitted, the associated softkey is masked out.
- If the instrument function is not available temporarily due to the remaining settings, the softkey is displayed without the 3D frame (softkey is displayed "flat").

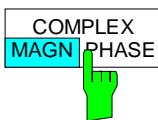
The softkeys are masked out with IEC/IEEE-bus control and during processing of a macro.

The menu display facilitates the orientation within the menu structure (see Section 2.3.5)

Depending on the associated functionality a coloured underlaid softkey or part of softkey has the following meaning:



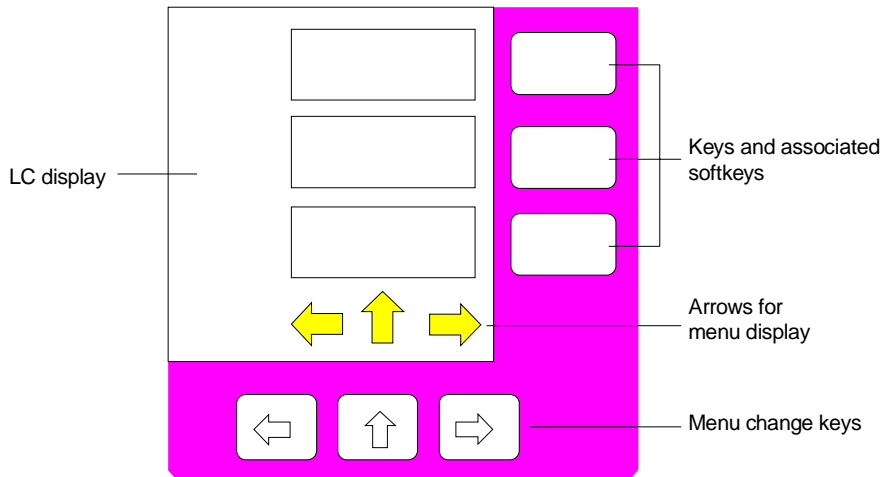
- Green: The corresponding instrument function is switched on.
- Red: Selection table or entry field is active.



The corresponding instrument function has two states, "MAGN" and "PHASE" in this example. The active state is underlaid (MAGN).

The menu display comprises three arrows which indicate the corresponding direction to be used to move within the menu tree. Arrows \leftarrow and \Rightarrow are displayed only if a right or left side menu is available. Arrow \uparrow is displayed in submenus only and indicates that a higher menu level can be accessed.

The arrows of the menu display are assigned to the menu change keys on the front panel below the softkey bar:



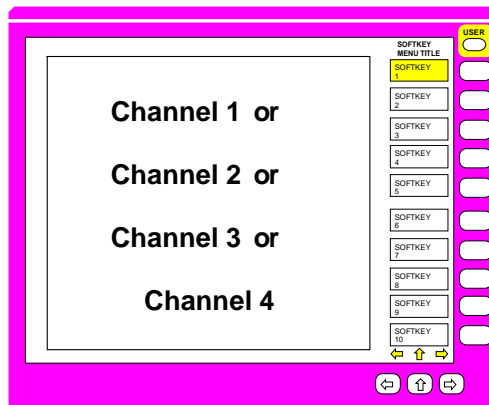
2.3.2 Subdivision of Screen - Display Modes

The measuring diagrams assigned to the four display channels (CH1 to CH4) can be displayed on the screen individually ('Single Channel') or in pairs of two ('Dual Channel') or all the four of them simultaneously ('Quad Channel'). Besides, they can either be displayed superimposed ('Overlay') or separated in different areas of the screen ('Split'). In addition, the displayed charts can be set to maximum size such that the labelling and softkeys are cancelled (Expand mode).

These corresponding settings are made in the *RESPONSE DISPLAY* menu.

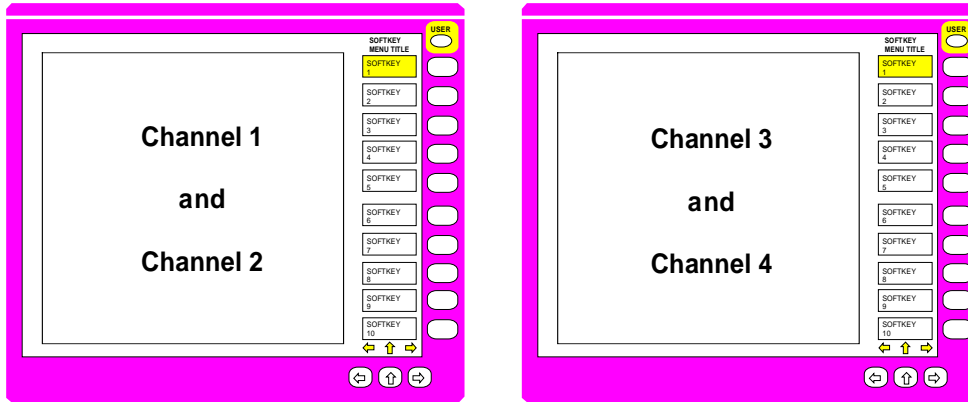
2.3.2.1 Single Channel

Only one of the four channels is displayed on the entire screen. This channel is the active channel. It is selected using the four keys *CH1* to *CH4* in the *CHANNEL* key field.



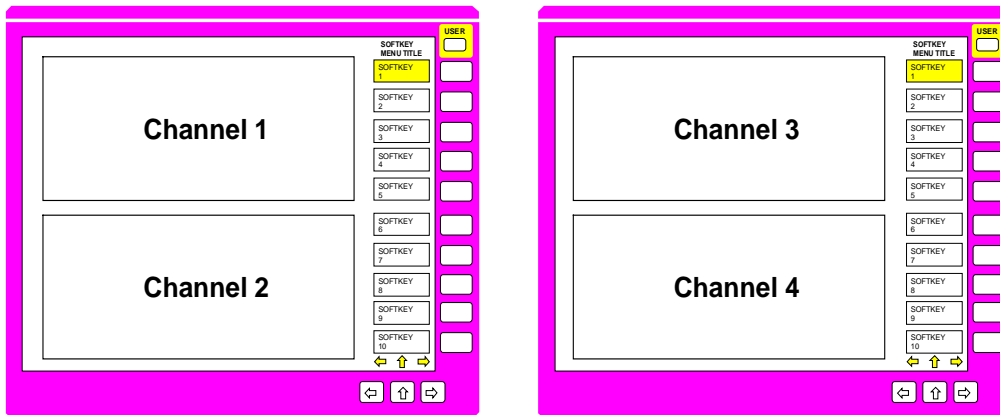
2.3.2.2 Dual Channel Overlay Overlay

Apart from the active channel, an additional channel is displayed. The channels are assigned to each other in pairs of two. Either channel 1 and channel 2 or, alternatively, channel 3 and channel 4 can be displayed simultaneously. In this setting either both forward scattering parameters or both reverse scattering parameters can be measured simultaneously. The diagrams of both channels are superimposed ('Overlay'). An information line is available for each channel. Decoupled channels also have their own sweep line. The lowest line is assigned to the channel with the highest number.



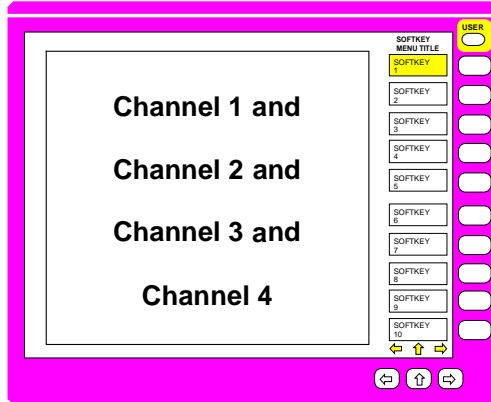
2.3.2.3 Dual Channel Split

Two separate diagrams are displayed. Here, too, either channel 1 and channel 2 or channel 3 and channel 4 are displayed together. The channel with the lower number is displayed in the upper half of the screen, the other channel in the lower half.



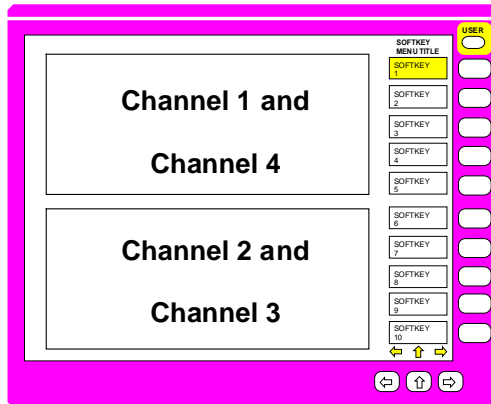
2.3.2.4 Quad Channel Overlay

The diagrams for all of the four channels are superimposed. Four information lines are arranged one on top of other with the order from top to bottom corresponding to the channel numbers. With decoupled channels, the sweep lines are arranged in the same way.



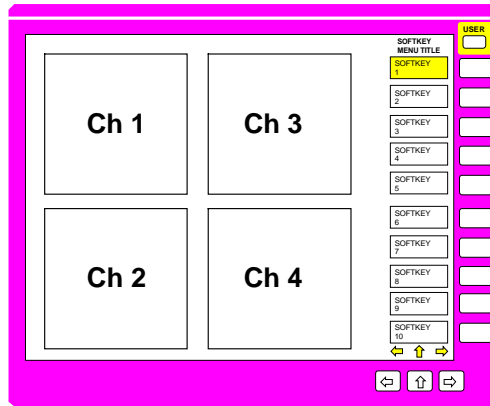
2.3.2.5 Quad Channel Dual Split

All of the four channels are displayed simultaneously, channels 1 and 4 overlaid in the upper half of the screen and channels 2 and 3 in the lower half. In this setting both reflection parameters and both transmission parameters can be displayed together in one diagram.



2.3.2.6 Quad Channel Quad Split

All of the four channels are displayed in separate sections. Channel 1 is displayed in the upper left quarter, channel 2 in the lower left quarter, channel 3 in the upper right quarter and channel 4 in the lower right quarter of the screen. The four S-parameters are arranged to correspond exactly to those in the two-port matrix.



2.3.2.7 Full Screen – Expand Mode

In this display mode, the diagram(s) is (are) expanded to maximum screen size. All labelings, enhancement labels, softkeys as well as the sweep indicator are omitted. Full screen is particularly suitable with fixed settings such as those used in production environments (see Section 2.14.5, *RESPONSE DISPLAY* menu).

2.3.3 Diagrams

The network analyzer offers various types of diagram for selection:

- **Cartesian diagrams**
 - with linear and/or logarithmic scaling,
- **Circle diagrams**
 - polar diagrams,
 - Smith charts,
 - inverted Smith charts and
 - charter diagram.

The type of diagram is selected in the *RESPONSE DIAGRAM* menu.

2.3.3.1 Cartesian Diagrams

A number of Cartesian diagrams may be selected.

- Abscissa (x-axis) with linear or logarithmic scaling
- Ordinate (y-axis) with linear or logarithmic scaling
- Division of the abscissa or ordinate into one, two or three segments which can be subject to linear or logarithmic scaling.

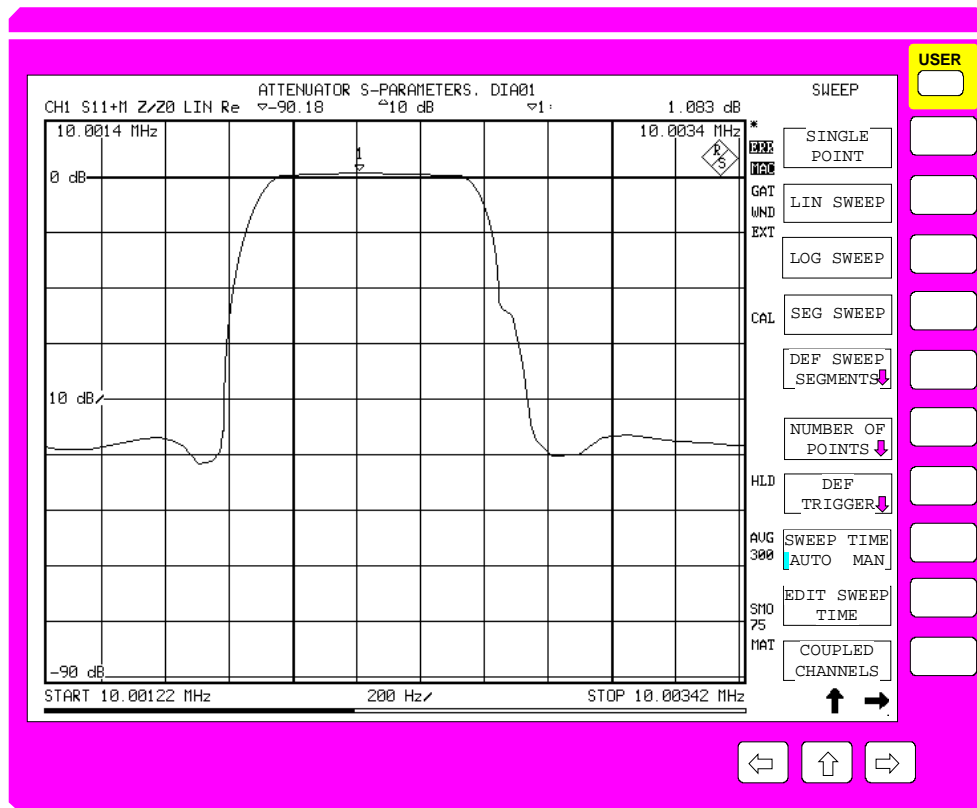


Fig. 2-14 Linear, Cartesian diagram

Abscissa scaling

The *START* and *STOP* or *CENTER* and *SPAN* keys in the *STIMULUS* key field specify the subdivision of the abscissa.

The axis labelling can be masked out for each channel, individually (*RESPONSE DIAGRAM - GRID ANNOTATION* softkey).

Linear abscissa division

The abscissa is scaled automatically depending on the sweep range selected. There is no fixed tenth-division scale (cf. ordinate scaling).

If start and stop values are entered, the intelligent grid can select between 5 and 15 grid lines.

If the center value is entered, the complete grid is arranged symmetrically around the center value. This makes the evaluation of filter adjustments, for example, easier.

Logarithmic abscissa division

The abscissa is divided into decades, each decade being divided **logarithmically** with the grid lines 1, 2, 3, 4, 5, 6, 7, 8 and 9. If the abscissa comprises more than 4 decades, the division scheme 1-2-4-6-8 is applied.

If the abscissa scale to be displayed comprises less than two octaves, the instrument automatically switches back to linear abscissa division.

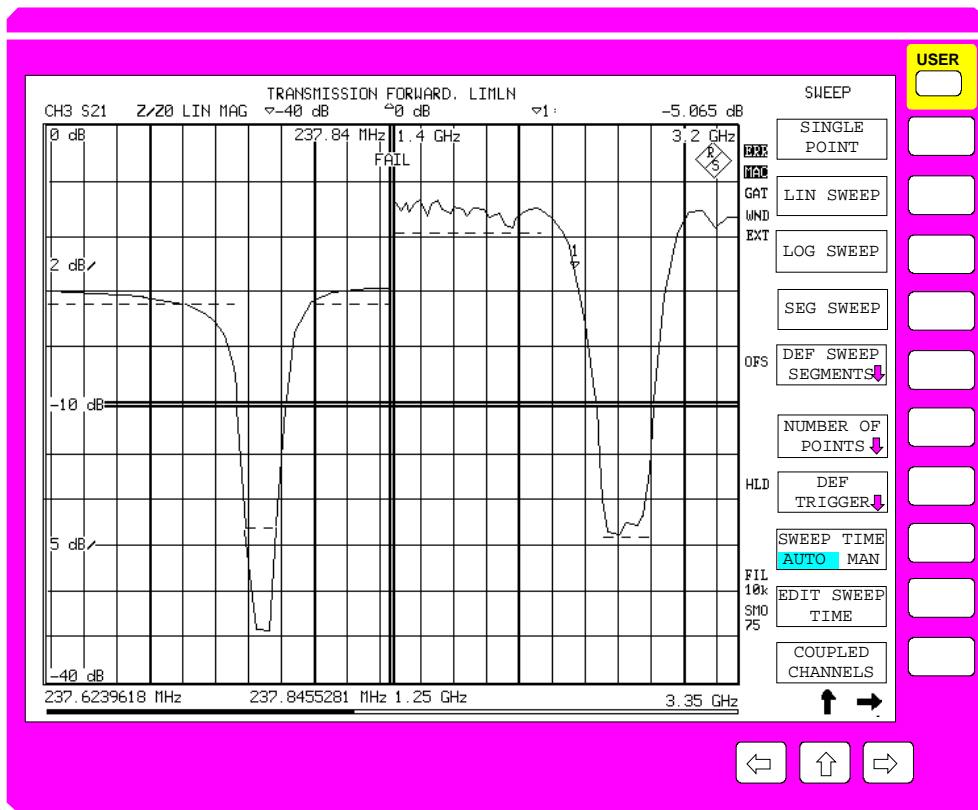


Fig. 2-15 Cartesian diagram with two segments on the abscissa and ordinate (single channel), each with limit lines and FAIL message

| | |
|-------------------------------------|--|
| Segmented abscissa | <p>For a segmented sweep with up to three non-overlapping segments, these segments can be separated graphically.</p> <p>In this display mode, all segments are of equal width whereas the swept range may differ in size. The segments may be scaled linearly or logarithmically (see Section 2.10, "Sweep Settings").</p> |
| Ordinate scaling | <p>The subdivision of the ordinate is specified in the <i>RESPONSE DIAGRAM</i> and <i>RESPONSE SCALE</i> menus.</p> <p>Similar to the abscissa, the axis labelling can be masked out for each channel, individually (<i>RESPONSE DIAGRAM - GRID ANNOTATION</i> softkey).</p> |
| Linear scaling of the ordinate | <p>The linear scaling of the ordinate can be specified in two different ways in the <i>RESPONSE SCALE</i> menu.</p> <ul style="list-style-type: none"><li data-bbox="635 715 1380 1108">• The tenth-division scale which is defined using the <i>SCALE/DIV</i>, <i>REFERENCE VALUE</i> and <i>REFERENCE POSITION</i> softkeys. The graphic distance between two grid lines inside the diagram is always 1/10th of the diagram height. One of the grid lines, the reference line is emphasized by a red triangle. The <i>REFERENCE POSITION</i> softkey allows for continuously setting the position of the reference line between 0 (lower edge of diagram) and 10 (upper edge of diagram) units of the grid. Shifting the reference line causes the complete y-grid to be shifted, ie the distance between the top and the bottom line of the grid and the edge of the diagram is not necessarily 1/10th of the diagram height.<li data-bbox="635 1161 1380 1372">– The flexible ordinate scaling which is defined by the maximum and minimum limit value of the diagram (<i>MAX VALUE</i> and <i>MIN VALUE</i> softkeys). Between five and fifteen lines are generated in a 1-2-5 grid. The position of this grid can be arbitrary concerning the maximum and minimum values of the diagram, ie it has no defined distance to the edges of the diagram. |
| Logarithmic scaling of the ordinate | <p>The logarithmic ordinate scaling is defined in the <i>RESPONSE SCALE</i> menu using the <i>MAX VALUE</i> and <i>MIN VALUE</i> softkeys.</p> <p>The logarithmic grid consists of a division into decades, each decade being divided logarithmically with 2, 3, 4, 5, 6, 7, 8 and 9. If the ordinate comprises more than 4 decades, the division scheme 1-2-4-6-8 is applied.</p> |

The logarithm function assigns real values to positive numbers, only. In order to allow for the representation of negative values and values with alternating signs in a logarithmic scale, the diagram is subdivided into an upper and a lower half. Logarithms of positive values are displayed in the upper half of the diagram, as usual. For negative values, the absolute value is taken and the logarithm of the absolute value is entered in the lower half of the diagram (mirror-symmetric to the positive values) Thus, except for zero, all real numbers can be represented in a logarithmic scale.

If the ordinate scale to be displayed is less than two octaves, the instrument switches back to linear ordinate scaling, automatically.

The limit of the logarithm at the origin (y tends to 0) is $-\infty$ (infinite). The gap around the symmetry axis of the diagram symbolizes the domain on the real ordinate axis, which contains negative, infinite logarithms.

The upper-edge of the upper half of the diagram, and the lower-edge of the lower half of the diagram are defined by MAX VALUE and the negative MAX VALUE.

The lower-edge of the upper half of the diagram, and the upper-edge of the lower half of the diagram (which are adjoined at the above-mentioned symmetry axis) are defined by MIN VALUE and the negative MIN VALUE.

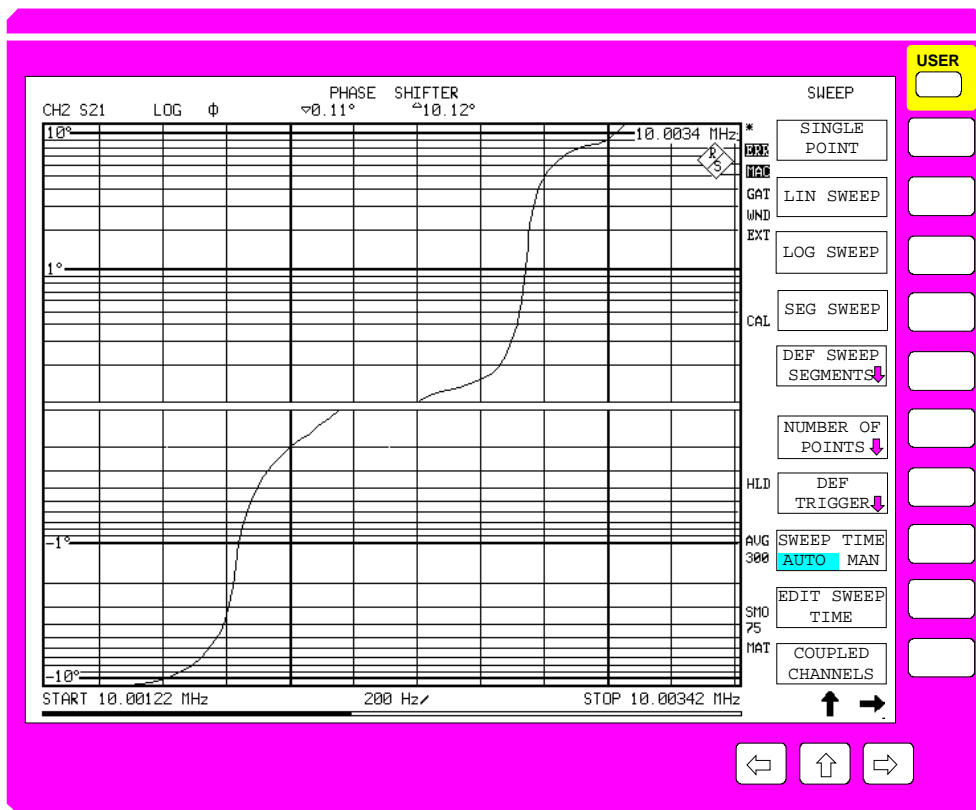


Fig. 2-16 Logarithmic Cartesian diagram with symmetric subdivision for positive and negative values

Segmented ordinate

Similar to the abscissa, the ordinate can be graphically subdivided into up to three segments.

In this display mode, all segments are of equal width, whereas the swept range may differ in size.

Unlike for the segmentation of the abscissa, however, the values of the borders of adjacent segments have to coincide, ie there must be no gaps between the segments. The segments can be scaled linearly or logarithmically.

The setting is made in the *RESPONSE DIAGRAM* menu.

2.3.3.2 Polar Diagrams

A large variety of polar diagrams is offered for selection.

- Diagrams with linear radial division,
- Diagrams with logarithmic radial division,
- Subdivision of the radial axis in a maximum of two segments which in turn can be subdivided linearly or logarithmically.

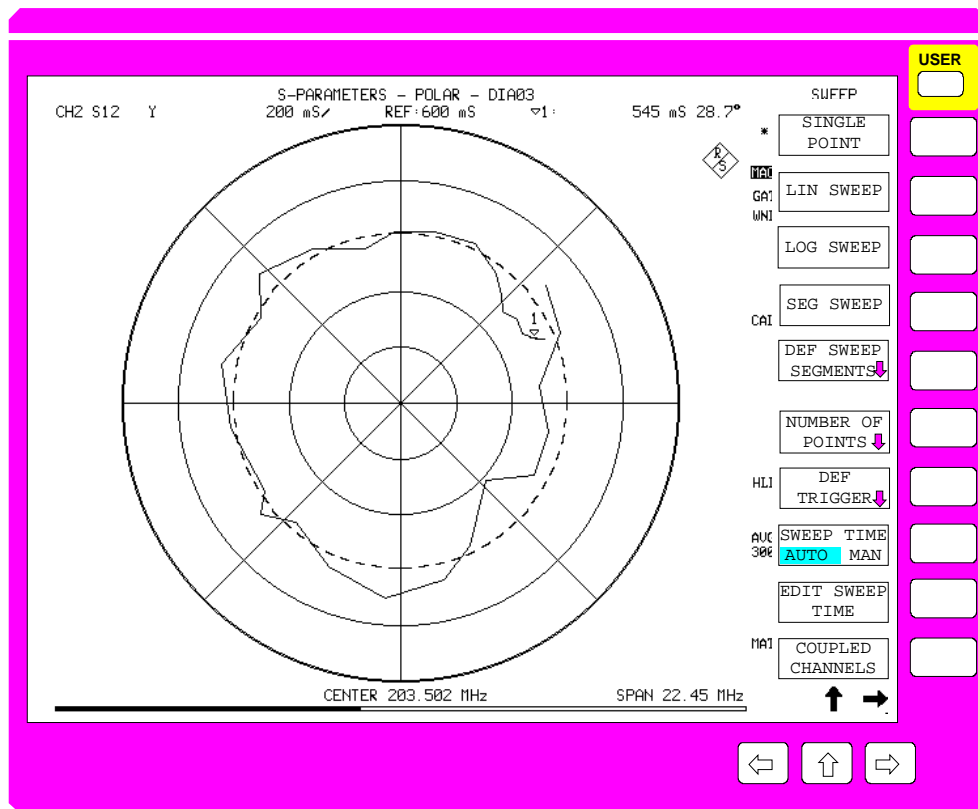


Fig. 2-17 Linear polar diagram (single channel)

Radial Scaling

The radial axis is not labelled. The scaling is indicated in the information line.

Linear radial axis

The linear, radial scaling can be defined in the *RESPONSE SCALE* menu in two different ways..

- The **fifth-division scale** which is defined using the *SCALE/DIV*, *REFERENCE VALUE* and *REFERENCE POSITION* softkeys. The graphic distance between two grid circles inside the diagram is always 1/5th of the diagram radius. One of the circles, the reference circle is bold. The *REFERENCE POSITION* softkey allows for continuously setting the position of the reference circle between 0 (center of diagram) and 5 (outermost circle of diagram) units of the grid. Shifting the reference circle causes the complete radial grid to be shifted.
- The *MAX VALUE* softkey defines the maximum amplitude value to be displayed in the diagram, that is the value of the outermost circle. The lower limit (*MIN VALUE*) is always zero, since it is the center of the polar diagram. The **flexible radial division** generates between three and eight circles in a 1-2-5 grid. Similar to the fifth-division scale, the position of this grid may be arbitrary relative to the diagram center.

Logarithmic radial axis

The logarithmic radial scaling is defined using the *MAX VALUE* and *MIN VALUE* softkeys in the *RESPONSE SCALE* menu.

In contrast to the linear polar diagram, this scaling requires definition of a lower limit value in order to fix the value of the interior edge of the polar diagram. Though the interior (circular) edge has graphically shrunk to a point in the drawing, its value must be defined in order to determine the number of decades.

The logarithmic grid is divided into decades, each decade being divided **logarithmically** with 2, 3, 4, 5, 6, 7, 8 and 9. If the radial axis comprises one decade only, the division scheme 1-2-4-6-8 is applied.

As the absolute value of a complex number is always ≥ 0 , an extension of the logarithm to negative values is not provided for polar diagrams.

Segmented radial axis

Analogous to the ordinate of a Cartesian diagram, the radial axis of a polar diagram can be graphically subdivided into two segments.

In this display mode, both (circular) segments are of equal width, whereas the swept range may differ in size.

The MIN- and MAX values indicated in the information line always refer to the maximum value of the exterior segment and to the minimum value of the interior segment. The minimum value of the exterior segment and the maximum value of the internal segment are always identical in order to prevent gaps or overlaps in the representation of the trace. These values are indicated in an individual info window, the scaling info window (see Section 2.3.4.5, Scaling Info Window). The segments can be scaled linearly or logarithmically.

For radial circle segments, there is no linear fifth-division scale with reference circle with radial segments. For the flexible, linear grid, the number of grid lines is reduced to 2 to 5. If one segment covers more than one decade in logarithmic scaling, the division scheme 1-2-4-6 is applied.

The setting is made in the *RESPONSE DIAGRAM* menu.

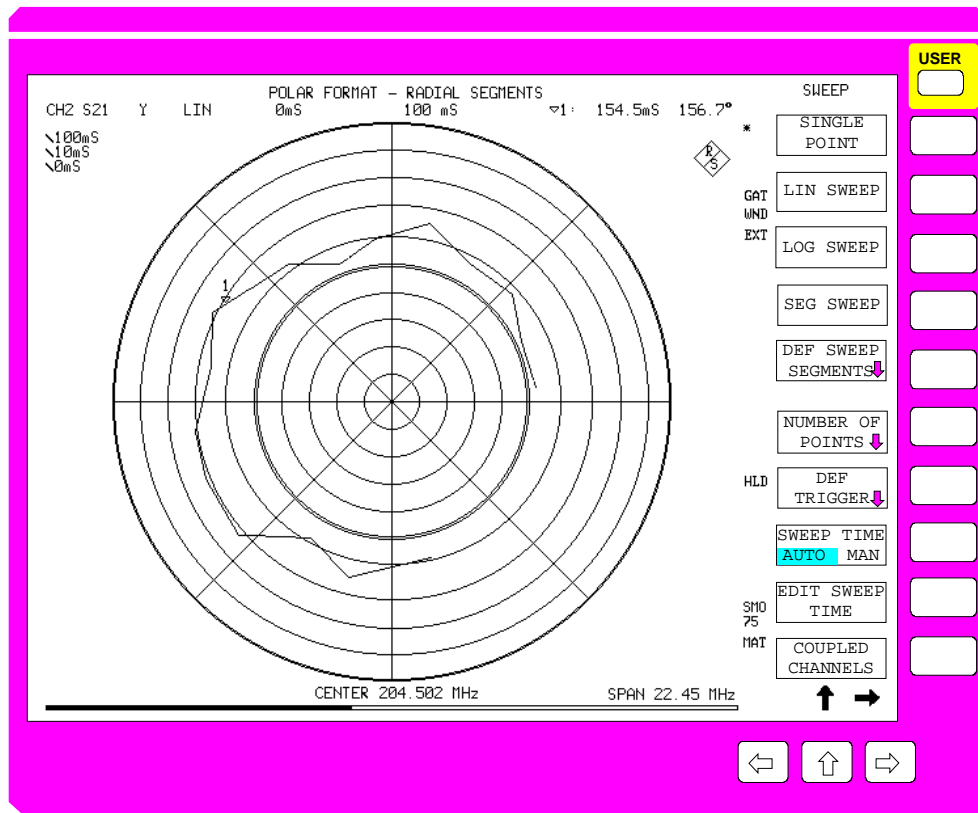


Fig. 2-18 Lin./ log. polar diagram with 2 segments (Single Channel)

Circular scaling

Circular scaling of the polar diagrams means the subdivision of the full circle of the diagram into sectors (ie the circle is sliced like a pie). Circular scaling is particularly suited for approximately reading off the phase of a measured complex value. Eight 'spokes' are drawn in all at a distance of 45° from each other and starting with 0°. All spokes are drawn from the center of the polar diagram to the periphery of the circle.

2.3.3.3 Smith Charts

In its basic state, the normal Smith chart, ie the interior of the unit circle of the reflection-coefficient plane, is drawn with the correspondingly labelled scaling lines. Smith chart scaling lines are circles of constant real part or circle segments of constant imaginary part of the impedance. A simple rescaling, where the matching point is kept as a center and the radius is arbitrarily chosen, is possible for Smith charts as well as for polar diagrams. In this case, labelling scaling lines is omitted. Apart from that, any circular sectors with arbitrary center can be marked and handled using the zoom function.

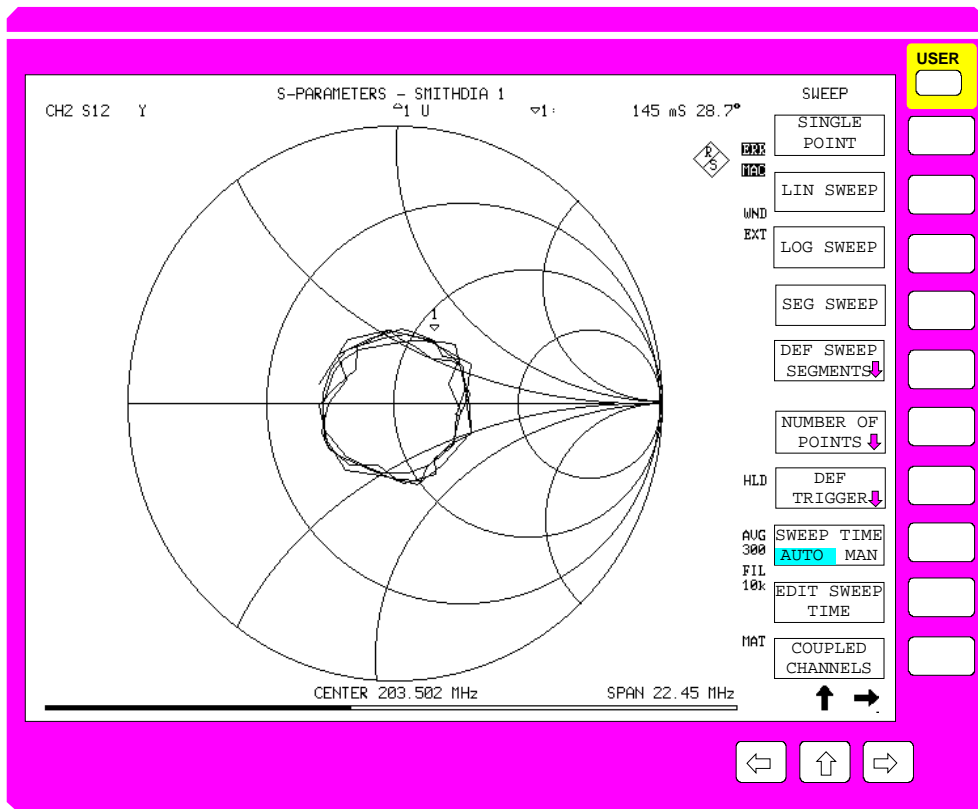


Fig. 2-19 Smith chart

2.3.3.4 Inverted Smith Charts

The same specifications which apply to the non-inverted Smith chart are valid for inverted diagram. The significant difference is that, instead of the impedance plane, the inverted impedance plane, ie the admittance plane is conformally mapped into the reflection-coefficient plane. Thus, compared to the ordinary Smith chart, the inverted Smith chart is a point-symmetric representation with respect to the matching point. The scaling lines are circles of constant conductance and circular segments of constant susceptance. Like the Smith chart, the inverted Smith chart allows the representation of circular zoom sectors of the passive and/or active domain with arbitrary center and radius.

2.3.3.5 Charter Diagrams

The charter diagram like the basic state of the Smith chart represents the interior of the unit circle of the reflection-coefficient plane, ie the complete passive range. Unlike the Smith diagram, the charter diagram is fixed, ie zooming even around the center, is not possible.

All specifications which apply to the Smith chart are valid for the charter diagram. The significant difference is that, instead of lines with constant real or imaginary parts of the impedance plane, circles with constant magnitude or radial lines with constant phase are conformally mapped into the reflection-coefficient plane. Thus, a charter diagram looks different from a Smith chart.

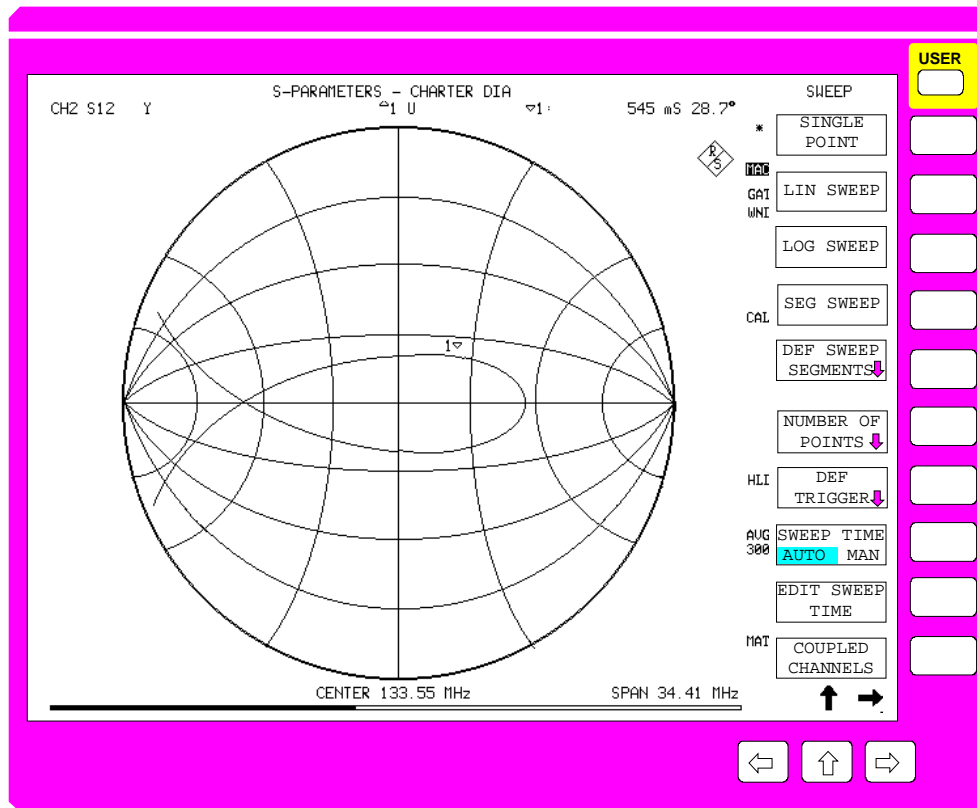


Fig. 2-20 Example of a charter diagram

2.3.4 Display Windows

Display windows are located inside the measuring diagram and display primarily measured values. In general, display windows do not allow any user entries. Exceptions are fields for confirming actions and yes/no-decisions required after some system messages.

The following windows are displayed:

- **Message fields**
The message fields read out messages, e.g., results of the Limit Check (PASS/FAIL).
- **Marker info list**
The marker info list indicates the positions of the markers/delta markers switched on.
- **Line info list**
The line info list indicates the positions of the display lines switched on.
- **System messages**
System messages read out warnings and error messages.
- **Scaling info field**
The scaling info fields indicate the scaling of the two segments of the radial axis with segmented polar diagrams and the three zoom parameters with zoomed Smith charts.

Note: *In contrast to the display windows, data entry windows are provided for definition of numeric and alphanumeric instrument parameters. Data entry windows are described in Section 2.3.6, "Setting the Parameters".*

2.3.4.1 Message Fields

Message windows provide notes on measurement runs or internal states of the instrument. These notes are no error messages, which are indicated as system messages.

Independent of the type of diagram and its arrangement the message fields are displayed in the upper half of the corresponding diagram. They appear on the screen and cannot be shifted by the user. They can be masked out by pressing any key.

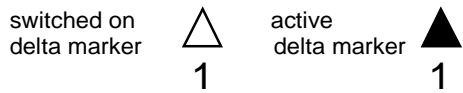
Pass/Fail info windows are message fields which indicate the result of the LIMIT CHECK.

2.3.4.2 Markers and Marker Info Lists

Markers are used to read out measurement values. The marker info list contains the positions, i.e., the stimulus and response values of the markers/delta markers switched on. Marker symbols represent the markers on the trace and in the marker lists.

switched on marker  active marker 

"Normal" markers are represented by triangles with their peak facing down. The peak coincides with the trace. The labeling (marker number) is positioned above the marker symbol. A filled triangle symbolizes the active marker.



Delta markers are represented by triangles with their peak facing upward. Again, the peak of the triangle points to the test point. Delta markers are labeled below the marker symbol. Similar to active markers, a filled triangle symbolizes an active delta marker.



Apart from markers and delta markers there are temporary markers which are used, e.g., for the analysis of shape-factor measurements etc. The symbols of temporary markers are the same as those of the markers, however, they are labeled with letters ("S" for shape-factor measurement in the example).

A separate marker info list exists for each channel. Consequently, two lists are displayed in Dual-Split mode and four marker info lists with Quad-Split mode. With overlay displays, the marker info list of the active channel is output, only. The space available for the marker info list may not be sufficient in all of the SPLIT SCREEN modes such that parts of the list may be indicated, only. Display of the complete list may be achieved by switchover to another display mode, if required.

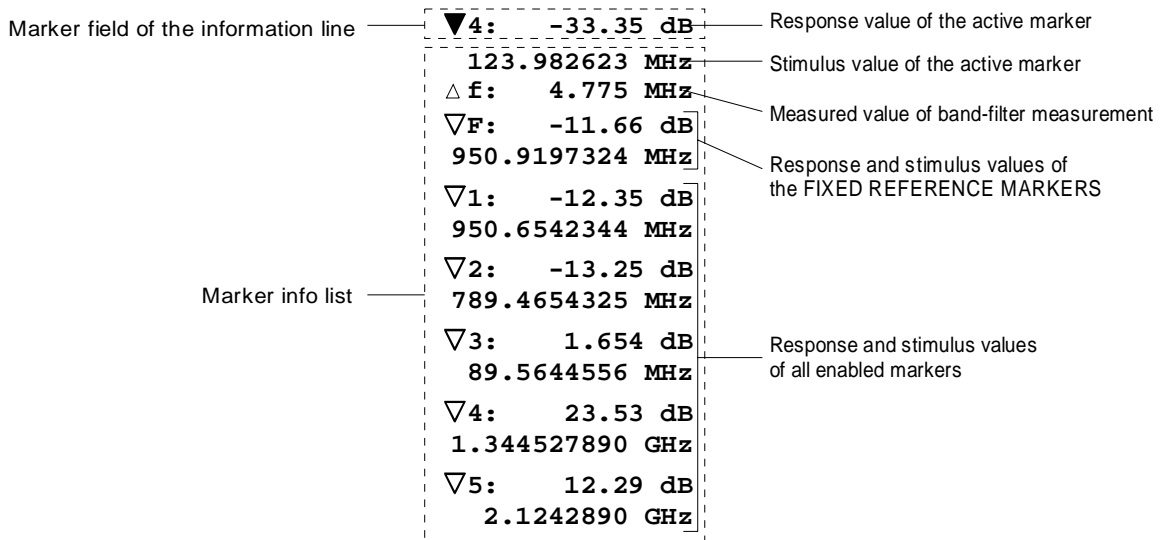
The marker info list is switched on and off in the *MARKER MARKER* menu.

The response value of the active marker is indicated in the so-called marker field of the information line. The marker info list is displayed just below the marker field. The marker info list contains the following information:

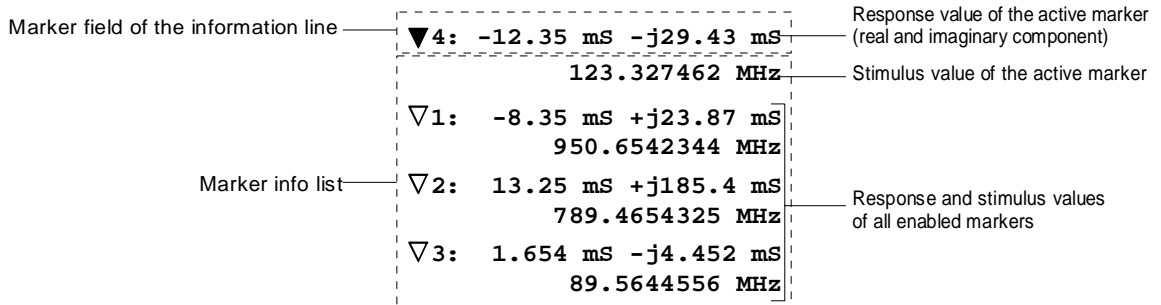
- The top line indicates the stimulus value of the active marker. In Quad Split mode and in Expand mode, the information line contains no marker field. The response value of the active marker appears at the beginning of the marker info list, instead.
- The next line indicates the result of band-filter measurements (e.g., bandwidth measurement).
- The subsequent lines contain the stimulus and response values of all enabled markers, sorted in ascending order. If the *FIXED REFERENCE MARKER* has been activated in the *MARKER DELTA* menu, it precedes the other delta markers.

The way the marker values are displayed in the information line and in the marker info list depends on the marker formatting (scalar or complex).

Example of the representation of marker values with scalar formatting:



Example of the representation of marker values with complex formatting:



2.3.4.3 System Messages

System messages are displayed if instrument settings occur which are erroneous or which require a decision to be taken by the user. The message field can be located at various positions:

- General messages which are not directly related to the measurement, appear in the center of the screen.
- Messages on the measurement being performed are centered in the diagram of the corresponding channel.

 System messages can be shifted on the screen using the mouse.

If a system message is displayed, all operations are interrupted (e.g., edit jobs in an entry window, table, movement of the axis cursor for zooming diagrams, etc.). The operations are continued after the system message has been deleted.

The headline of the window indicates the type of error: WARNING, ERROR or SYSTEM MESSAGE.

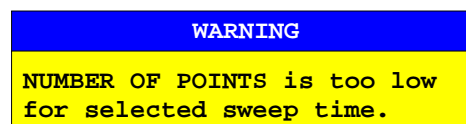
There are two types of system messages:

Message without action field

These system messages contain only arbitrary information. They hint at events which are of interest for the user but do not affect the measurement or functioning of the instrument.

They are deleted either automatically after a predefined time has passed (3 seconds) or upon any keystroke or mouse click.


Example:



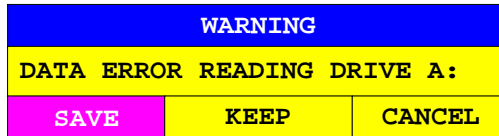
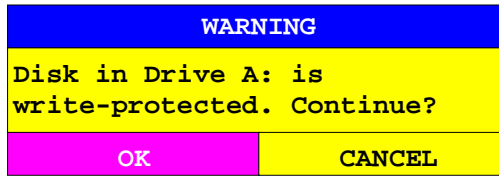
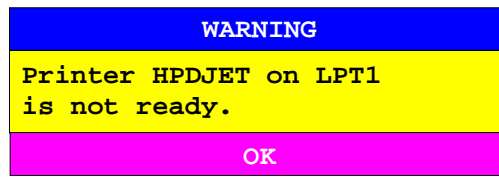
Message with action field

These system messages require a decision to be taken by the user. They are not deleted until any action has been selected. Deletion of the message initiates the action selected and appropriate measures to be taken. The action field consists of one (OK), two (OK/CANCEL) or three (arbitrary) buttons.

The user may select one of the buttons using the cursor keys and initiate the associated action by means of the units prefix keys. The CLR key is used to acknowledge the message without releasing any action.

 The buttons may be selected by the mouse, if connected.

Examples:



Some system messages are directly produced by the instrument hardware and therefore not displayed in separate windows. Examples are the overload message which indicates the level at one of the instrument connectors is too high (CAUTION: OVERLOAD ON PORT1) or the message indicating that there is no external reference source (CAUTION: REFERENCE UNLOCKED). These messages are displayed in the middle of the left display margin, without a window but in red typeface. They won't disappear until the error is corrected.

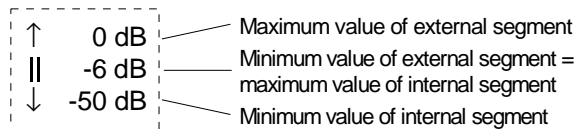
2.3.4.4 Scale Reference Fields

A scale reference field is always shown in the upper left edge of the diagram, if segmented polar diagrams or zoomed Smith charts (also zoomed inverted Smith charts) are displayed. This field contains the scaling of the two segments of the radial axis in case of segmented polar diagrams or three zoom parameters for zoomed Smith charts.

An individual scale reference exists for each channel such that a maximum of four different reference fields (with Quad-Channel-Quad-Split display) are displayed. With overlay display, the scale reference field of the active channel is displayed, only.

Scale reference field in segmented polar diagrams

The segmented polar diagram consists of an interior and an exterior segment. Thus, the scale reference field consists of three lines:



Scale reference field in zoomed Smith chart

The zooming area in a Smith chart is defined by specification of a circular section (the zoom circle) by means of circle center and radius. The scaling info field thus consists of three lines:

| | | | |
|---|---------|----|--------------|
| x | -310 mU | —— | x coordinate |
| y | 180 mU | —— | y coordinate |
| r | 230 mU | —— | Radius |

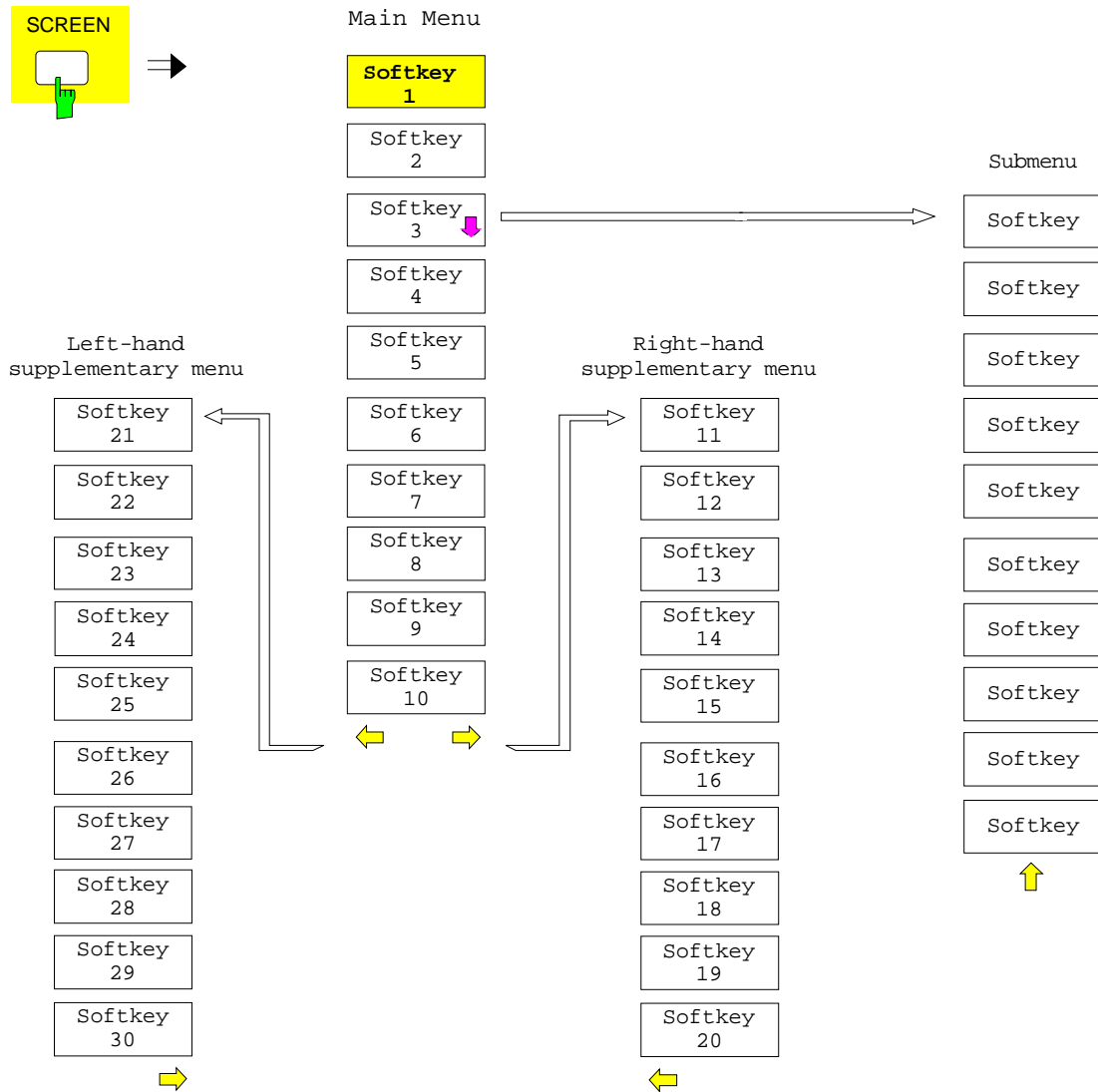
- The first line contains the title "x", followed by the x-coordinate of the center of the zoom circle (which is equal to the real component of the complex reflection coefficient).
- The second line contains the title "y", followed by the y-coordinate of the center of the zoom circle (which is equal to the imaginary component of the complex reflection coefficient).
- The third line contains the title "r" followed by the radius of the zoom circle.

All of the three values are calculated by the scaling algorithms of the Smith chart and entered in the scale reference field. The zoom parameters are converted into diagram coordinates and not displayed as a percentage of the diagram width (as with entry of the zoom circle by the user). The zoom parameters are dimensionless.

2.3.5 Calling and Changing the Menus

The operation of the network analyzer is menu-controlled via keys and softkeys. Various softkey menus are displayed depending on the instrument status. The individual menus constitute the so-called menu tree. The top menu (the root of the menu tree) is always called by means of a keystroke. Each softkey menu consists of max. 30 softkeys, 10 softkeys being arranged in a main menu, 10 in a left-hand supplementary menu and 10 in a right-hand supplementary menu. Empty supplementary menus are not displayed. Arrows at the lower edge of the softkey area indicate whether a supplementary menu can be entered or not.

The individual softkeys allows for branching into further menus (so-called submenus):



The menu arrows at the lower edge of the softkeys make it easier for the user to "navigate" through the menu tree.

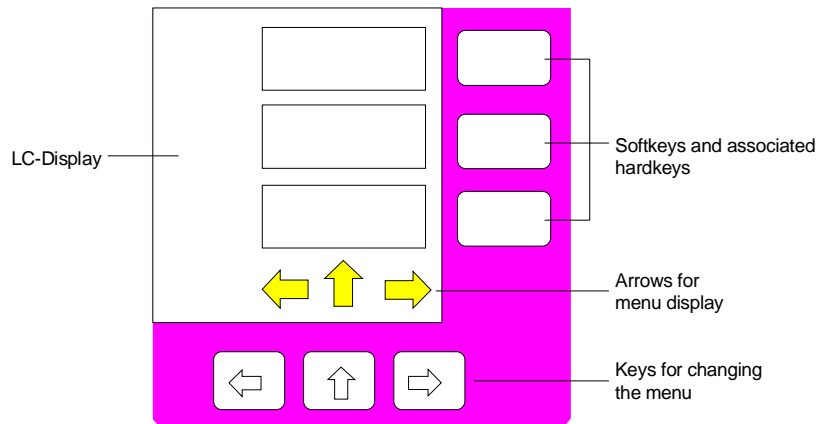


These arrows indicate that this menu has a left-hand and a right-hand supplementary menu.



This arrow indicates that this menu was called from a higher-order menu.

The arrows are assigned to the menu change keys on the front panel below the softkey line, which allow for switching between the main menu and the supplementary menus and submenus:



The menu change keys have the following functions:



These keys are pressed to call the left-hand and right-hand supplementary menus.



This key is pressed to return to the higher-order menu which is located one hierarchy level above in the menu tree, i.e. the menu from where the current submenu was called up. In several submenus, the command is automatically returned to the higher-order menu when a softkey is pressed.

The right-hand supplementary menu cannot be called up directly from the left-hand supplementary menu and vice versa, it is necessary to go via the main menu.

Submenus are always called up by a softkey.



The labelling of all softkeys which call a submenu includes a ↓ arrow.



The menu arrows can be selected directly via a mouse click, if connected.

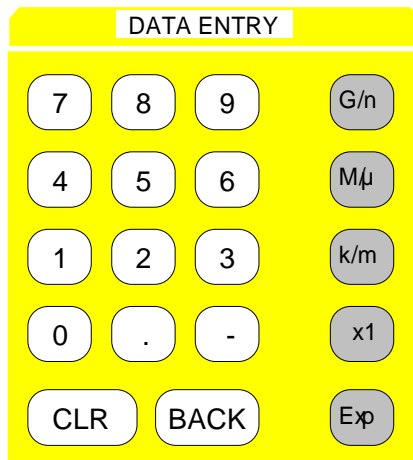
2.3.6 Setting the Parameters

Parameters are set either by simple selection (selection parameters) or by alphanumeric entries in data entry windows.

The numeric keypad on the front panel, an external keyboard (optional), a roll-key and the cursor keys are provided for the entry of instrument parameters in an entry window or in a table.

The external keyboard is optional. If it is not fitted, the auxiliary line editor is called automatically for entry of alphanumeric parameters. The auxiliary line editor provides for selection of individual letters and a number of special characters which are copied into the actual entry window.

2.3.6.1 Numeric Keypad – *DATA ENTRY* Key Group



The *DATA ENTRY* block is provided for entry of numeric parameters. It contains the following keys:

- Number keys 0...9
- Decimal point
Inserts a decimal point "." at the cursor position.
- Sign key
Changes the sign of the mantissa or exponent of a numeric parameter.
A "-" is inserted at the cursor position in case of an alphanumeric parameter.
- Units prefix keys (G/n, M/μ, k/m and x1)
Provide the numeric value entered with the selected unit and terminate the entry.

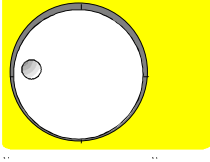
The units prefix keys are all assigned the dimension "1" for dimensionless quantities or for level entries (e.g., in dB). The units prefix keys thus assume the function of an *ENTER* key. The same applies for an alphanumeric entry.

The units prefix keys are also used to open and close selection fields in tables (sub-tables).

- Exponent key (*EXP*)
Adds an exponent (E-xx) to the end of the numeric entry.
- Clear/ Entry off key (*CLR*)
The *CLR* key is assigned various functions:
 - Aborts the entry before it has been terminated.
 - Deletes the complete entry string just being entered with numeric entry. This is easier than using the *BACK* key.
 - Deletes system messages.
- Backspace key (*BACK*)
 - Deletes the character left to the cursor with numeric entry.
 - Allows for toggling between the current and the previous values subsequent or prior to entry (*UNDO* function).

2.3.6.2 Roll-key and Cursor Keys

The roll-key and the cursor keys are arranged below the numeric keypad.



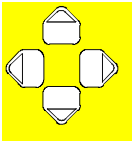
The roll-key has various functions.

- For entry, the instrument parameter is incremented (turning clockwise) or decremented (turning counter-clockwise) by a defined step size.



The step size may be equal to or smaller (e.g., 1/10) than the step size being defined for the cursor keys (see description of the *STEP* key).



- In tables, the roll-key can be used to shift the cursor horizontally or vertically when no entry window is open. The direction (horizontal/vertical) is switched over using the cursor keys.
- Selection of the individual letters with the auxiliary line editor.
- Shifting of markers, display lines, limit lines etc. on the screen.

The roll-key provides an acceleration algorithm, i.e., the variation step size increases with increasing rotational speed.



The cursor keys shift the cursor to the wanted position in a table.

The cursor keys  and  shift the cursor to the wanted position in the (alpha)numeric editing line.

- The cursor keys  and 
- increase or decrease the instrument parameter by the selected step size with numeric entry.
 - allow for toggling between the editing line and the auxiliary line editor with alphanumeric entry.

2.3.6.3 Selection of Parameters

The selection of parameters and their settings is effected by means of a key, a softkey or in a table depending on the hierarchical level of the menu they are assigned to.

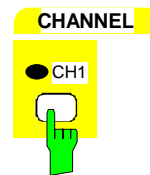
Selection via key

Most keys of the network analyzer are used to enter menus where the selection and the settings are made. Few settings can be made directly by means of a keystroke, only.

Example: channel selection

- Press *CHANNEL CH1* key

Channel 1 is active and is displayed on the screen. The LED above the key is lit and indicates the selection.



Selection via softkey

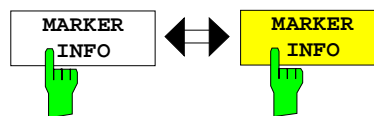
In most cases the selection is made by pressing the respective softkey. There are various alternatives of making the selection:

1. The softkey is active or inactive.

Example: switching on or off the display of the marker info list

- Press *MARKER MARKER* key.
- Press *MARKER MARKER - MARKER INFO* softkey.

Each time the softkey is pressed, the marker info list is switched on or off. If the softkey is active (= marker info list on), it is illuminated.

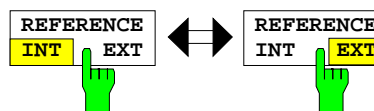


2. The softkey acts like a toggle switch, each pressing changes the active selection.

Example: Selection of the reference (internal or external)


- Press the *SYSTEM SETUP* key.
- Press *SYSTEM SETUP - REFERENCE INT/EXT* softkey.

With each pressing, the checkmark on the softkey changes from INT (internal reference) to EXT (external reference) and vice versa. When in the active setting the softkey menu item is illuminated

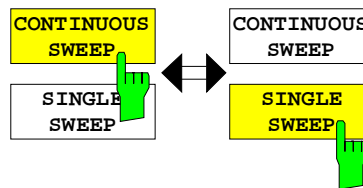


3. Various softkeys act like selection switches. Only one softkey may be active at a time.

Example: sweep setting


- Press the *SWEEP SWEEP* key.
- Press menu-change key .
- Select the *SWEEP SWEEP - CONTINUOUS SWEEP* softkey.

The continuous sweep is thus set. The *CONTINUOUS SWEEP* softkey is colored (factory-set: green). The second alternative, a series of n sweeps according to the trigger definition, can be selected via the *SINGLE SWEEP* softkey in the same menu. Only one of the two softkeys can be active at a time, the softkeys thus act like selection switches.

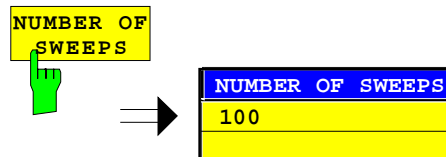


4. The softkey is used to select the parameter, the setting is made in an alphanumeric data entry window.

Example: *SWEEP COUNT* parameter

- Press the *SWEEP SWEEP* key.
- Press the menu-change key .
- Select the *SWEEP SWEEP - SWEEP COUNT* softkey.

The window for entering the number of sweeps for the *SINGLE SWEEP* mode is opened. The softkey is colored (factory-set: red). (Data entry is described in the next section).

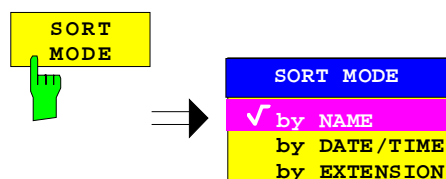


5. The softkey selects the parameter, the setting is made in a selection table.

Example: Selection of the sorting criteria of a file list

- Press the *MEMORY CONFIG* key.
- Press the *MEMORY CONFIG - SORT MODE* softkey.

A selection table is displayed. The softkey is colored (factory-set: red). (operation see below)



Selection in a table

The network analyzer uses numerous tables for display and configuration of instrument parameters.

The tables differ considerably in the number of lines, columns and inscriptions. The basic steps of operation for the selection and setting of parameters are, however, the same for all tables. Shown below is the typical entry of parameters into a table using a sweep segment list as an example.

Note:

Most of the tables are coupled to a softkey menu which provides further functions for editing table entries such as deletion of tables, copying of lines or columns, marking of table elements, restoring default states.

The definition of individual tables and the operation of particular editing functions can be looked up in the description of the corresponding softkey menu.

1. Activating the table

If the menu has only one table, the latter is activated automatically subsequent to calling this menu in most cases and the marking cursor is positioned to the top field of the left column.

If the menu contains various tables, the table of interest must be selected using the softkey which is labeled with the title of the table.

2. Selection of the parameter

| SWEEP SEGMENTS | | | | | | | |
|----------------------------|---------|---------|--------|---------|--------|-----|-------|
| OVERLAPPING SEGMENTS: 4, 5 | | | | | | | |
| SEGM | START | STOP | POINTS | SRC PWR | TIME | AVG | IF BW |
| ✓ 1 | 100 MHz | 150 MHz | 50 | 10 dBm | AUTO | 1 | 1 kHz |
| ✓ 2 | 150 MHz | 160 MHz | 200 | 0 dBm | 100 ms | 10 | 10 Hz |
| ✓ 3 | 160 MHz | 500 MHz | 50 | 0 dBm | AUTO | 1 | 1 kHz |
| ✓ 4 | 500 MHz | 510 MHz | 200 | 0 dBm | 200 ms | 10 | 10 Hz |
| ✓ 5 | 500 MHz | 1 GHz | 100 | 0 dBm | AUTO | 1 | 1 kHz |

Selection bar

Selection of the parameter (or the setting) is made using the marking cursor

- Press the cursor keys to move to the wanted field.

or

- Rotate the roll-key until the wanted field is marked. The cursor keys are used to specify the direction of the roll-key movement (horizontal or vertical)

When shifting the cursor, elements may be skipped which can not be edited. Table elements, which can not be selected are indicated by a different color.

- Press one of the units prefix keys (Δ the *ENTER* key). The parameter/the setting has been selected.

The selected parameter can be edited the way described below:

3. Editing the marked parameter

| SWEEP SEGMENTS | | | | | | | |
|----------------------------|---------|---------|--------|---------|--------|-----|-------|
| OVERLAPPING SEGMENTS: 4, 5 | | | | | | | |
| SEGM | START | STOP | POINTS | SRC PWR | TIME | AVG | IF BW |
| ✓ 1 | 100 MHz | 150 MHz | 50 | 10 dBm | AUTO | 1 | 1 kHz |
| ✓ 2 | 150 MHz | 160 MHz | 200 | 0 dBm | 100 ms | 10 | 10 Hz |
| ✓ 3 | 160 MHz | 500 MHz | 50 | 0 dBm | AUTO | 1 | 1 kHz |
| ✓ 4 | 500 MHz | 510 MHz | 200 | 0 dBm | 200 ms | 10 | 10 Hz |
| ✓ 5 | 500 MHz | 1 GHz | 100 | 0 dBm | AUTO | 1 | 1 kHz |

Checkmark

| STOP FREQUENCY |
|----------------|
| 500 MHz |
| |
| |

| AVERAGING |
|-----------|
| 1 |
| 10 |
| 20 |
| 50 |
| 100 |
| 200 |
| 500 |

a) Toggling between two states

If an element of a table can be switched on and off only, the units prefix keys are used to toggle between these two states.

- Press one of the units prefix keys. The table element is switched on and provided with a checkmark. (✓).
- Press one of the units prefix keys once more. The table element is switched off.

b) Opening a data entry window

If a table entry consists of an (alpha-) numeric value, selection of the latter causes the corresponding entry window to be opened.

Note: For numeric or alphanumeric instrument parameters, the editing operation may be started by entering any number or letter on the front panel or on the external keyboard. In this case, the data entry window is opened automatically.

c) Opening a selection table

If a table entry may have various states (e.g., colors from a color pallet, fixed filter bandwidths, etc.), a table indicating all possible states is displayed with selection. The current state is and marked by a checkmark and by the cursor.

- Set the cursor to the desired setting.
- Press one of the units prefix keys. The setting is switched on and marked (√). The selection table closes and the value is transferred to the original table. The cursor is positioned automatically on the next table element.

Abortion of entry



- Press the CLR key.

The current entry/selection is aborted and the original setting is restored.

Scrolling

Some tables contain more entries than can be displayed on one screen page. In this case, a **scrollbar** is displayed at the right margin of the table, whose slider shows the current position in the text.


- Actuate the PAGE UP or PAGE DOWN softkeys. The table is paged forward or back by one page.

- Press cursor key  or .


The table is scrolled up or down by one line.

| SWEEP SEGMENTS | | | | | | | |
|----------------------------|---------|---------|--------|---------|--------|-----|-------|
| OVERLAPPING SEGMENTS: 4, 5 | | | | | | | |
| SEGM | START | STOP | POINTS | SRC PWR | TIME | AVG | IF BW |
| √ 1 | 100 MHz | 150 MHz | 50 | 10 dBm | AUTO | 1 | 1 kHz |
| √ 2 | 150 MHz | 160 MHz | 200 | 0 dBm | 100 ms | 10 | 10 Hz |
| √ 3 | 160 MHz | 500 MHz | 50 | 0 dBm | AUTO | 1 | 1 kHz |
| √ 4 | 500 MHz | 510 MHz | 200 | 0 dBm | 200 ms | 10 | 10 Hz |
| √ 5 | 500 MHz | 1 GHz | 100 | 0 dBm | AUTO | 1 | 1 kHz |

Slider

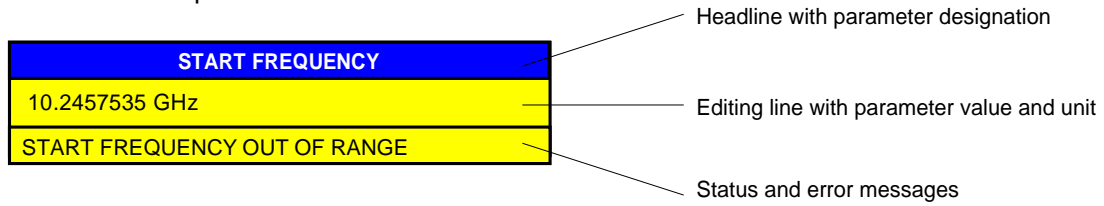


Scrollbar



2.3.6.4 Editing of Numeric Parameters

The entry of numeric values is always made in a data entry window, which is displayed automatically after selection of the parameter.



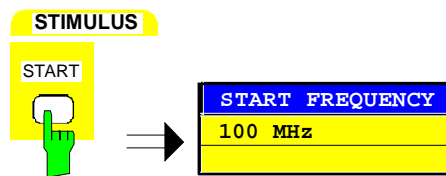
The headline indicates the name of the instrument parameter, which has been selected. The entry is made in the editing line. Subsequent to calling the entry window, the current parameter value including the unit is displayed left-justified in the editing line. Status and error messages which refer to the current entry are displayed in the third and (optionally) fourth line.

Note: Entry windows may be represented transparent (cf. RESPONSE DISPLAY menu)

Entry of a numeric value

- Call data entry window (cf. selection of parameters)
The editing line indicates the current value

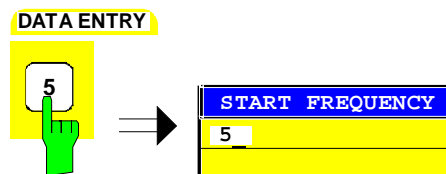
Example: start frequency (frequency-sweep mode)





Entry via number keys

- Press a number key.
The previous value is deleted. The number is displayed in the editing line with the cursor then positioned to the right of the number.
- Enter further numbers, correspondingly.

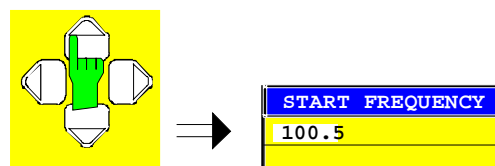
Example:



Entry via cursor keys

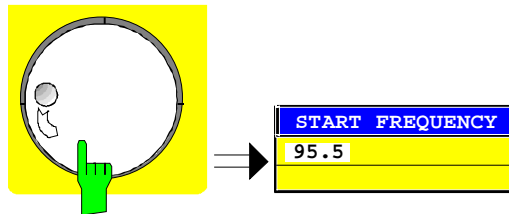
- Press the cursor  or  until obtaining the required value.
The parameter is incremented or decremented by the step size which has been set in the STEP menu.

Example:



- Entry via roll-key ➤ Rotate the roll-key until reaching the required value.
- The parameter is varied by the step size which was set in the STEP menu for this parameter. The variation step size increases with increasing rotational speed.
- Turning the roll-key clockwise increments the value, turning it counterclockwise decrements the value.

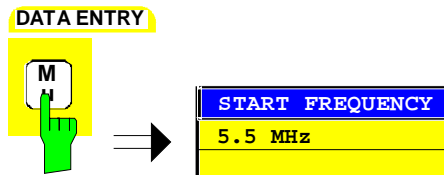
Example:



Terminating the entry



- Press one of the units prefix keys or the $\times 1$ -key.
- The unit is entered in the entry window and the new setting is accepted by the instrument.
- A few data entry windows close automatically whereas others like the entry window for the start frequency remain open even after termination of the entry. They can be closed by pressing the *CLR* key.





Example:



If an error occurs, a corresponding error message is displayed in the status line of the entry window, e.g., "Out of range", "Value adjusted", etc. In this case, the new value is not accepted for the instrument setting.

Correcting the entry

- Deleting an entry
- Position the cursor beside the digit which is to be deleted using the cursor keys  .
 - Press the *BACK* key. The entry left to the cursor is deleted.
 - Enter new numbers. The number is inserted to the left of the cursor, the other numbers are shifted right.
If the maximum amount of characters for the mantissa or the exponent has been entered, no further entry is possible (no horizontal scrolling).

- Restoring the original value
- Press the cursor  or 
 - or
 - press the *BACK* key.
For numerous parameters, the data administration of the instrument stores the previously valid parameter value in addition to the current value. The *BACK* key/the cursor keys  or  can be used to toggle between these two values. This applies for terminated entries as long as the data entry window is displayed. Any characters positioned to the right of the cursor when it overflows will be lost.

Aborting the entry

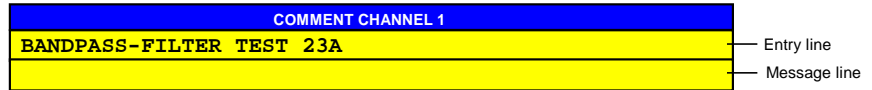
- Press the *CLR* key.
The original parameter value is restored. The new entry is deleted.
- Press *CLR* key again.
The entry window is closed, the original value remains active.
- or
- Press any key or any softkey (even the softkey which has opened the entry window).
The entry is aborted and the entry window is closed. The original value remains active.

- An auxiliary line editor or an external keyboard (optional) are provided for the entry of alphanumeric instrument parameters .

The roll-key and the exponent key have no function with alphanumeric entry. All units prefix keys assume the function of an ENTER key.

The entry is always made in a data entry window which is displayed automatically upon selection of the parameter. The editing line comprises 60 characters. Up to 256 characters may be entered. If a text exceeds 60 characters the contents is shifted automatically 20 characters left or right when the left or right margin of the editing line is touched by the cursor.

2.3.6.4.1 Editing With External Keyboard



Entry of text

- Select parameter.
The data entry is active automatically upon calling the data entry window. The cursor is positioned at the beginning of the previous entry.
- Press the required character on the keyboard.
The character is inserted prior to the cursor.
- Enter further characters

Correcting the entry

- Delete the entry using the *DELETE* key or *BACKSPACE* key.

Terminating the entry

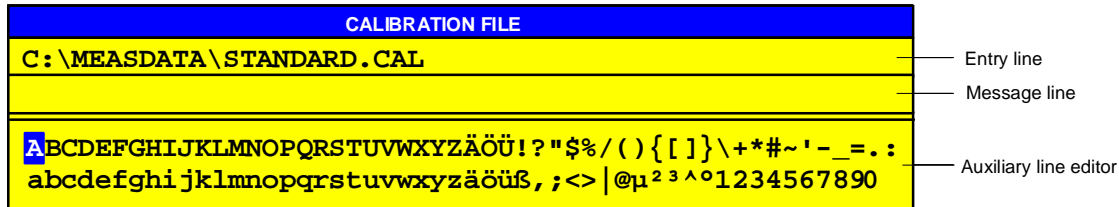
- Press the *ENTER* key of the external keyboard
The data entry window is closed and the new value is accepted for the instrument.



Aborting the entry

- Press the **CLR** key on the front panel
- or
- any softkey.
- The data entry window is closed, the original value is retained.




2.3.6.4.2 Editing with Auxiliary Line Editor

If the external keyboard is not fitted, the auxiliary line editor is called automatically with entry of alphanumeric parameters. The auxiliary line editor is an extension of the alphanumeric entry window. It contains the complete alphabet with uppercase and lowercase letters as well as special characters in two lines of 52 characters, each. Individual letters and a series of special characters can be selected in the auxiliary line editor and copied into the entry line.






The cursor keys  and  toggle between entry in the editing line and selection in the auxiliary line editor.


Entry of text

- Select parameter.
The data entry is active automatically upon calling the data entry window. The cursor is positioned on the left in the editing line.
- Position the cursor in the auxiliary line editor using the cursor key .
The cursor marks the first letter of the editor.
- Locate the cursor on the character which is to be entered into the editing line using the cursor keys  and .
- Press one of the units prefix keys.
The character is entered in the editing line.

Correcting the entry

- Locate the cursor in the editing line using the cursor key .
- Position the cursor after the character which is to be deleted using the cursor keys  and .
- Press the *BACK* key.
The entry left to the cursor is deleted.

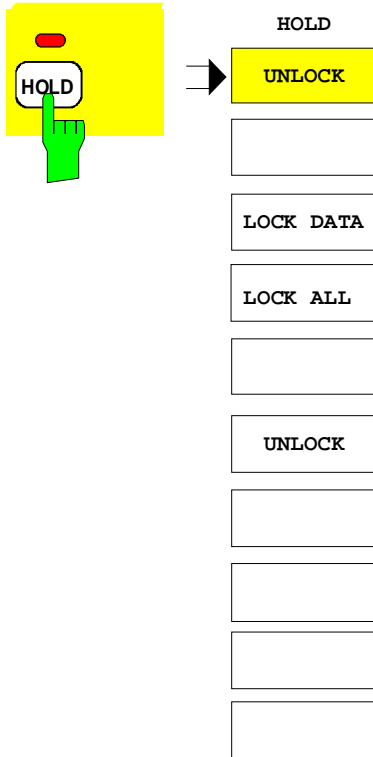
Terminating the entry

- Locate the cursor in the editing line using the cursor key .
- Press any units prefix key.
The data entry window is closed, the new entry is accepted by the instrument.

Aborting the entry

- Press the *CLR* key.
The data entry window is closed, the previous entry is retained.

2.3.7 Disabling the Control Elements - HOLD Key

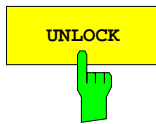


The functions of the *HOLD* menu disable either a subset of the control elements or the complete instrument control in order to prevent parameters from being changed by mistake.

The LED above the *HOLD* key indicates that the disable function has been activated.

Control can be enabled again by successively pressing the two *UNLOCK* softkeys in any order.

Instrument control is also enabled again when the instrument is switched off. This ensures that it can be operated normally when it is switched on again.





There are two *UNLOCK* softkeys in the *HOLD* menu. Successively pressing them in any order will enable instrument control again. The LED above the *HOLD* key then goes out.



If a mouse is connected to the instrument, it can be used to click on the two *UNLOCK* softkeys one after the other.



The *LOCK DATA* softkey disables the roll-key and the increment functions of the cursor keys  and  on the front panel and external keyboard.



The *LOCK ALL* softkey disables the complete front panel (including the *PRESET* key and roll-key), the mouse and all keys of the external keyboard. It is then not possible to exit the *HOLD* menu.

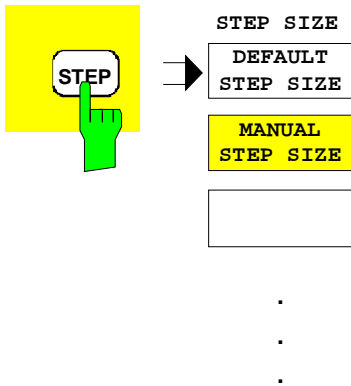
The only control elements which are not disabled are the two *UNLOCK* softkeys. They are used to enable instrument control.

2.3.8 Setting the Step size - STEP Key

The value of many of the numeric instrument parameters can be incremented or decremented in steps in a data entry window with the cursor keys (⏪ or ⏩) or the roll-key.

The step size used by the cursor keys can be specified in the STEP menu, whereby a different step size can be defined for each of the variable parameters.

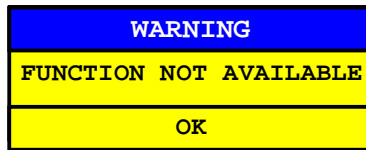
- Note:**
- It is not possible to set the step size by all of the numeric parameters.
 - An extended STEP menu is available by some parameters. The extra functions are described by the respective parameter.
 - Setting the step size has no effect on the roll-key (the resolution of the roll-key is higher than that of the step size function).



The STEP key opens the STEP menu for entry of the step size.

The step size of an instrument parameter can only be varied when this parameter is being edited in an entry window.

The STEP menu is disabled if no instrument parameter is being varied or if the parameter being edited does not support step size variation (as is the case by all of the alphanumeric parameters). The system message is displayed:



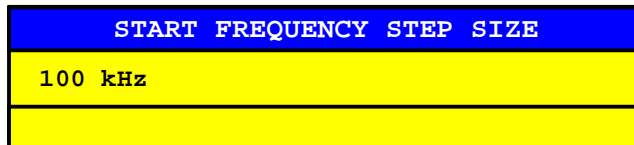
The message window can be closed via CLR or an arbitrary units prefix key.

The STEP menu is closed after a successful entry or if the DEFAULT STEP SIZE softkey is pressed. The previously active menu is shown.

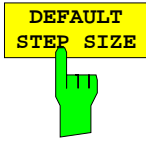


The MANUAL STEP SIZE softkey opens an entry window for definition of the step size of the active parameter. The name of the parameter whose step size is to be varied is displayed in the headline of the entry window:

Example:



The step size is no longer coupled to other instrument parameters. It remains constant until a new value is entered or until the DEFAULT STEP SIZE function is activated.



The *DEFAULT STEP SIZE* softkey sets the step size of the active instrument parameter automatically, i.e. the step size depends on other parameters and is automatically varied whenever these parameters are changed.

Example:

The step size of the *CENTER* frequency depends on the selected span.

2.3.9 Mouse and External Keyboard Control

2.3.9.1 External Keyboard


After an external keyboard has been connected to the instrument, additional characters for entry are available (letters and special characters). It is permitted to use the front panel keys and the external keyboard at the same time. The number, cursor and sign keys on the external keyboard have the same effect as the corresponding front panel keys. A few keys of the external keyboard provide an extended functionality for the entry windows and tables.

The assignment of external keyboard keys to the corresponding front panel keys is shown in Appendix E.




2.3.9.2 Mouse Control of Data Entry Windows and Tables

If a mouse is connected, additional functions are provided in the entry windows and tables. To operate these additional functions, additional buttons are displayed.

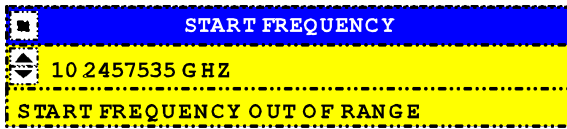
Essentially, all definitions which have been made for entry windows and tables also apply for mouse control. Note, however, the following deviations:

- The so-called close button  is displayed in the left margin of the headline and some tables. Selecting this button via the mouse aborts the entry and closes the entry window. Any changes made are discarded. This corresponds to the function of the *CLR* key with manual control.

Tables which are coupled to a softkey menu cannot be explicitly closed and therefore do not have a close button. They can only be closed by changing menus.

- In numeric entry windows, two buttons () are displayed in the left margin of the editing line. Simply clicking the buttons increments or decrements the parameter. This corresponds to the function of the keys  /  or the roll-key with manual control.
- The cursor is positioned in the editing line by clicking a character with the mouse.
- A table entry is selected by clicking it with the mouse. Double-clicking a table entry either opens a data entry window or a selection list, or allows the entry to be toggled.
- A character in the letter field of the auxiliary line editor can be selected by a single click of the mouse. A double click copies the character from the letter field into the editing line.
- To scroll the visible lines of a table: click the scrollbar, keep the mouse button pressed down, and slide the mouse.
- Open entry windows and tables can be moved across the complete screen using the mouse; they must not, however, be superimposed on the softkey area. Moving is performed by clicking the headline and sliding the mouse while the mouse button is being pressed.

Example: Numeric entry window with mouse control



2.3.9.3 Mouse Control of Display Elements

All display and control elements (enhancement labels, softkeys, function labels, display and limit lines, etc.) which are displayed on the instrument's screen can be controlled with a mouse.

Exactly one softkey or hard key is assigned to each display element. Double-clicking an element opens the corresponding menu.

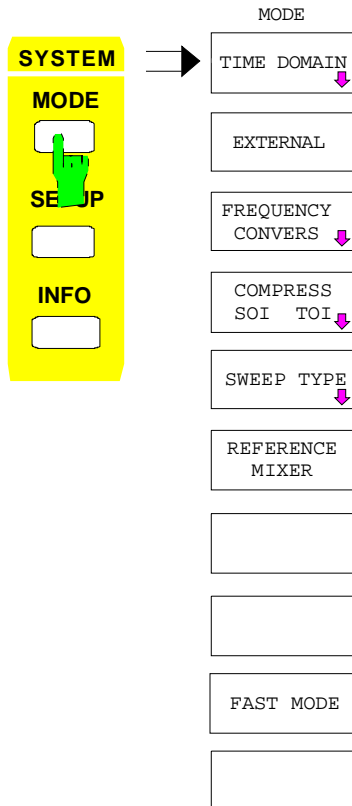
Many display elements are channel-dependent, e. g. all entries in the information line. If display elements of an inactive channel are clicked, the instrument also changes channels, i.e. the inactive channel becomes the active channel.

The assignment of softkeys/keys to display elements is shown in Appendix E.

2.4 General Configuration – *SYSTEM* Key Group

2.4.1 Selection of the Operating Mode – *MODE* Key

SYSTEM MODE menu:



The *MODE* key opens the menu for setting the measuring mode of the network analyzer (NWA). Some of the modes require the installation of options.

The *MODE* key is selected for

- configuration of the time domain transformation (*TIME DOMAIN*),
- switching between internal and external mode,
- configuration of frequency-converting measurements,
- configuration of compression and intercept point measurements (*COMPRESS SOI TOI*),
- selection of the sweep type,
- switch-on/off of reference mixer mode,
- switch-on/off of fast mode.

These operating modes partly exclude each other. The respective operating mode can be switched on/off with the softkeys in the *MODE* menu or a submenu can be called up with the softkeys in the *MODE* menu to configure and activate/deactivate an operating mode. In the latter case the softkeys both have a 1-out-of-N select function but also a switch-on/off function to activate an operating mode, ie the corresponding operating mode is deactivated again by pressing the active softkey.

In the default state

- the measurements are carried out in the frequency domain without time domain gating,
- the internal test set is used to perform the measurement,
- the generator and receiver sections assume the fundamental frequency,
- compression and intercept measurements are switched off,
- the sweep carried out is a frequency sweep,
- the reference mixer mode is switched off,
- the measurements are carried out at ordinary speed.

2.4.1.1 Time Domain Transformation (Option ZVR-B2)

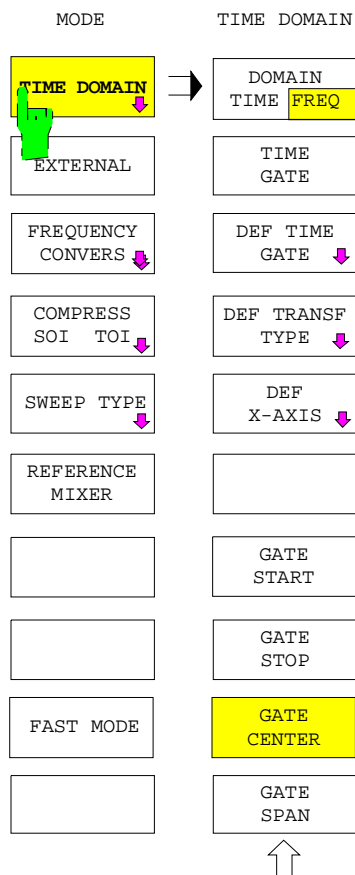
Time domain transformation is used for the display of measured values in the time domain. The data measured in the frequency range are transformed to the time domain using inverse FFT (fast Fourier transform). This type of representation is particularly informative and easy to interpret.

Either the impulse response or the step response, ie the response of the DUT to a pulse or to a step function, can be generated. This allows the position in time or space of impedance steps or faults to be easily determined. They can be suppressed with the aid of gates, ie filters in the time domain. Shape, position and width of the gates can be set by the user.

A particularly powerful tool is the subsequent retransformation to the frequency range of the response filtered in the time domain. Thus transitions, multiple reflection or crosstalk, which can make the frequency-domain response completely unrecognizable, can be almost entirely suppressed in the time domain. After filtering, the response can be represented in the frequency domain free from distortions.

Important: All parameters and functions of time domain transformation **can be set independently** for the display channels CH1 to CH4 **even if the channels are coupled** (SWEEP SWEEP - COUPLED CHANNELS). This simplifies simultaneous display of time and frequency domain measurements using different types of transformation, parameters and gate functions.

SYSTEM MODE - TIME DOMAIN submenu:



The *TIME DOMAIN* softkey opens the submenu for switching on/off and configuring the time-domain transformation mode. A prerequisite is that Time Domain option ZVR-B2 is installed.

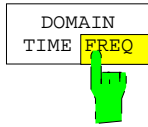
The following actions can be performed:

- Switchover between frequency and time domain (*DOMAIN TIME FREQ*),
- switching on and off the time gate,
- defining the shape and position of the gate in the time domain (*DEF TIME GATE*),
- selecting the transformation type (*DEF TRANSF TYPE*),
- changing the x-axis scale (*DEF X-AXIS*),
- positioning the gate on the x-axis (*GATE START, GATE STOP, GATE CENTER, GATE SPAN*).

When the *TIME DOMAIN* menu is called up, the auxiliary lines for editing position and width of the gates are automatically activated and the gate can be shifted by varying the center frequency (*GATE CENTER*). Before the menu is called, the gate is switched off (the *TIME GATE* softkey is grey).

2.4.1.1.1 Switchover between Frequency and Time Domain

SYSTEM MODE - TIME DOMAIN submenu:



The *DOMAIN TIME FREQ* softkey permits switchover between frequency and time domain.

The frequency domain is the default setting (after PRESET).

Switch-on of the time domain is signalled by the enhancement label *TIM* (short form for TIME). The time is then entered using the STIMULUS keys (*START*, *STOP*, *CENTER*, *SPAN*).

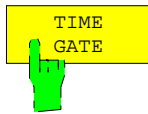
2.4.1.1.2 Selecting the Gate

The ideal gate for filtering in the time-domain would be a gate with infinitely steep edges and without sidelobes, ie a perfectly square gate. This could only be obtained, if the values were measured in an infinitely wide frequency range.

The network analyzer can only measure in a limited frequency range (eg 9 kHz to 4 GHz). As a result the gate is distorted after transformation to the time domain, which is shown by a finite edge steepness and ringing in the passband and stopband range.

The following gates available for selection offer different compromises between edge steepness and sidelobe.

SYSTEM MODE - TIME DOMAIN submenu:

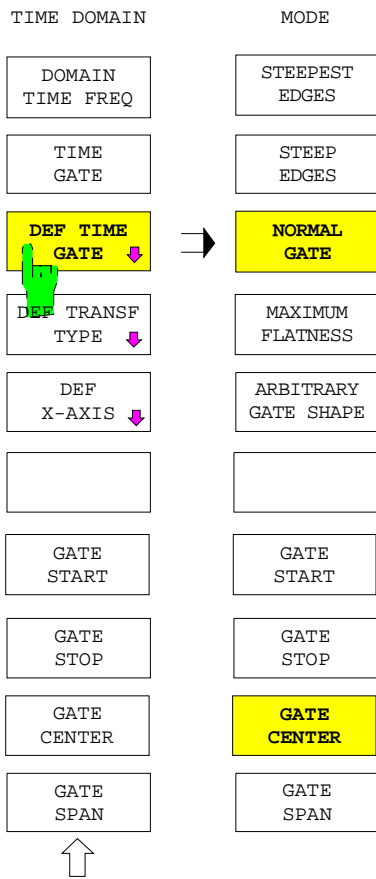


The *TIME GATE* softkey switches on a (time domain) gate (default status is off = no gate). When a gate is active, the enhancement label GAT (short form of GATE) is displayed. If a gate is switched on while values measured in the frequency domain are displayed, the message FREQUENCY DOMAIN DATA WILL BE TIME GATED is displayed to avoid a misinterpretation of time-filtered data (which might appear unusual) in the frequency domain.

Note:

For frequency-domain measurements with the gate switched on, the frequency sweep data is transformed to the time domain and multiplied with the gate function and then retransformed to the frequency domain. This processing method allows the usual display of a complex quantity depending on the frequency. However, the transmitting function of the DUT is only determined in the gate width.

SYSTEM MODE - TIME DOMAIN - DEF TIME GATE submenu:



The *DEF TIME GATE* softkey opens the submenu for configuring the time domain gate:

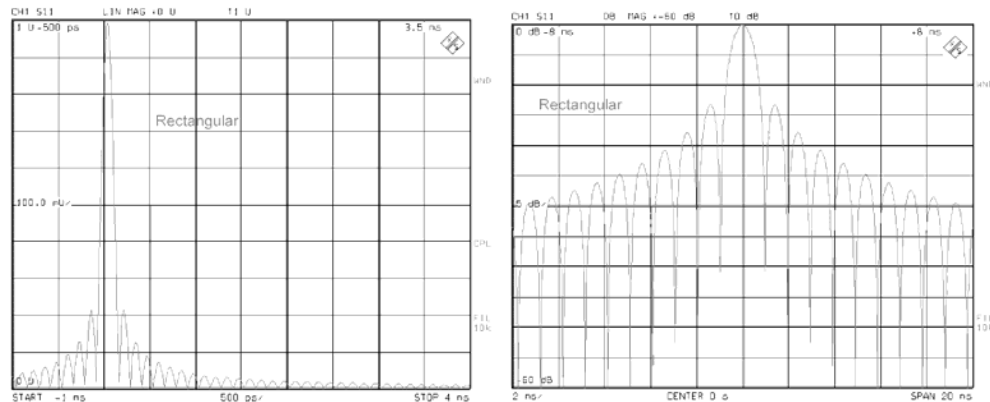
- The first five softkeys of this submenu serve for changing the gate shape.
- The next 4 softkeys determine the position of the gate on the time axis.

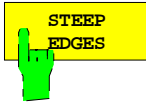
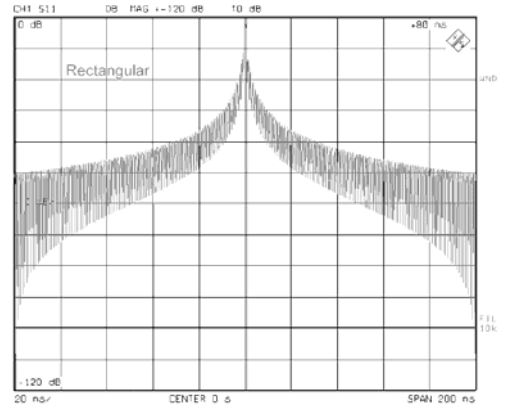
The set functions and values remain stored when the submenu is quit and can thus be used unchanged when the submenu is recalled.



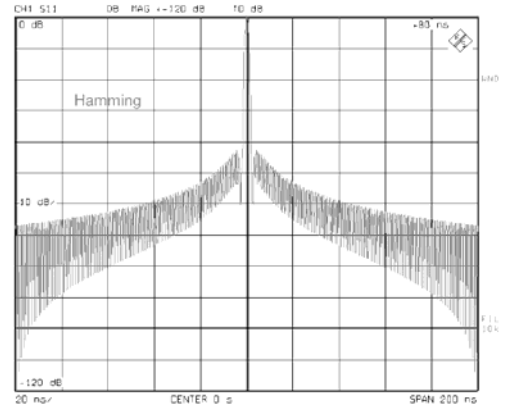
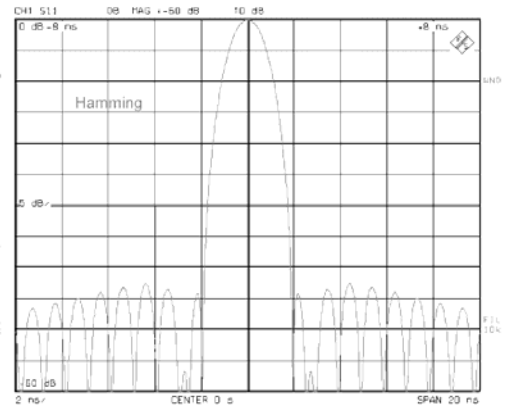
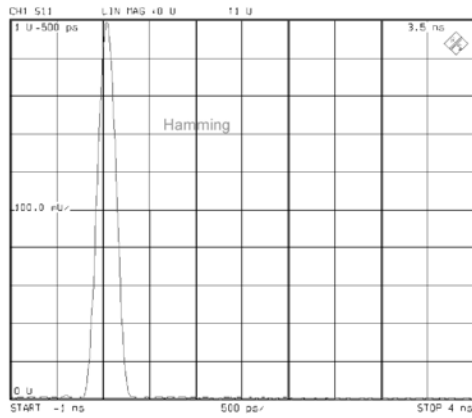
The *STEEPEST EDGES* softkey switches on the gate (rectangle) with the steepest edges. It has the shortest rise time. This means on the other hand that high ringing occurs in the passband and stopband and that the spectrum shows high sidelobes (13 dB).

This gate should be used whenever relatively small distortions must be filtered out in the immediate vicinity of the useful signal (in the time domain) and if demands on amplitude accuracy are only moderate.



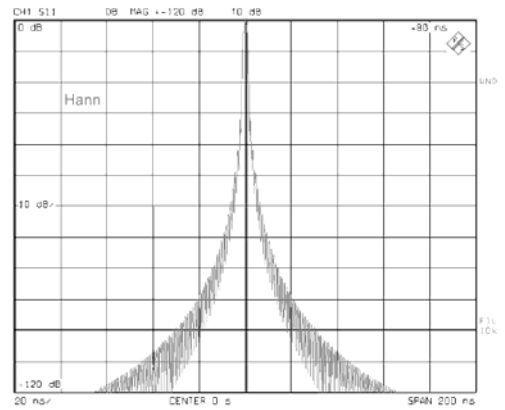
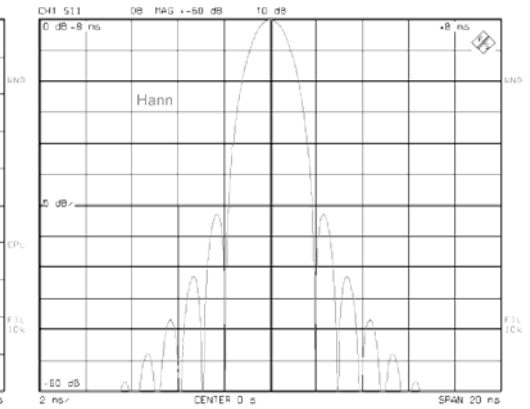
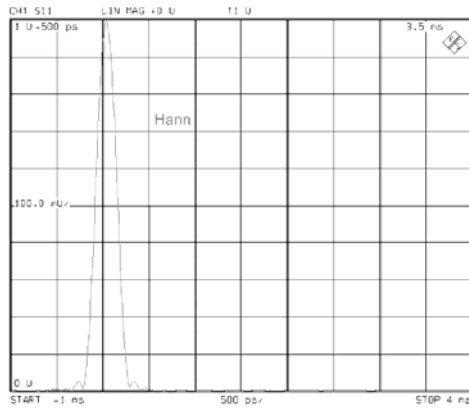


The *STEEP EDGES* softkey switches on a gate (R.W. Hamming) with less steep edges than the rectangle gate (STEEPEST EDGES). Ringing is considerably reduced as against that of the rectangle gate; the same applies to the height of the sidelobes (43 dB) in the spectrum.

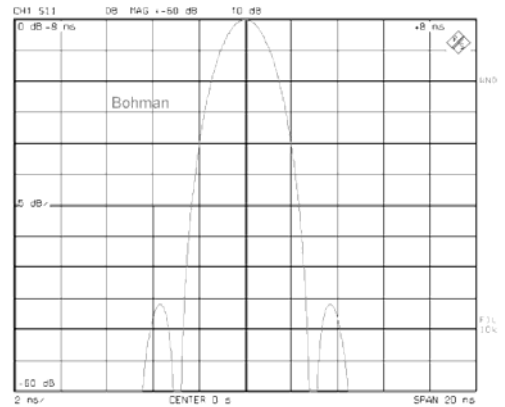
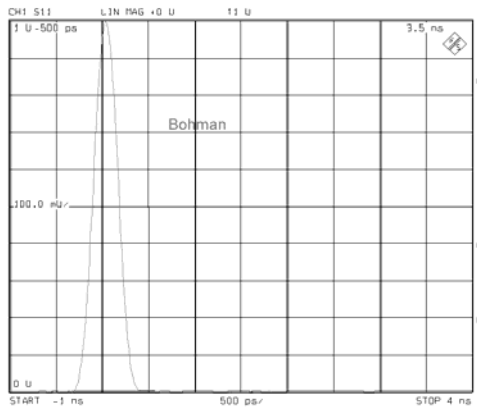


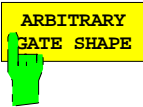
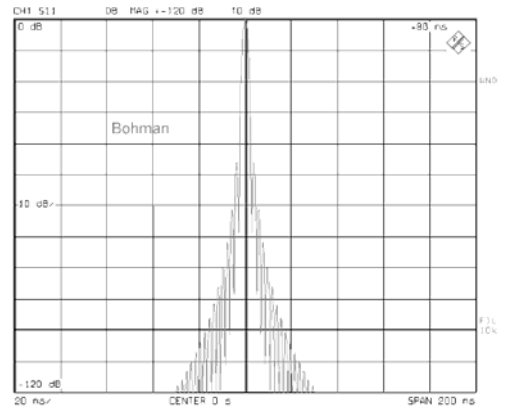


The *NORMAL GATE* softkey switches on a gate (Julius von Hann) of even flatter edges. This gate represents a good compromise between edge steepness and ringing at moderate sidelobe suppression (31 dB). It is recommended for most applications. This gate is automatically selected in the default state (after PRESET).

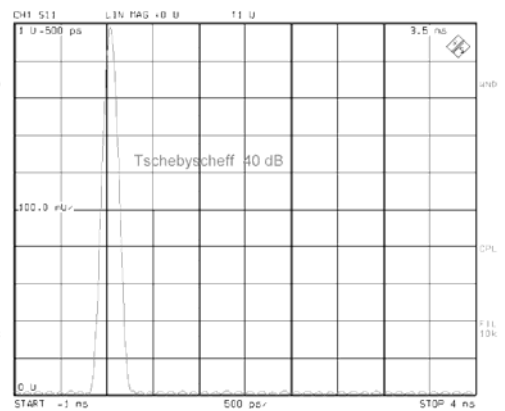
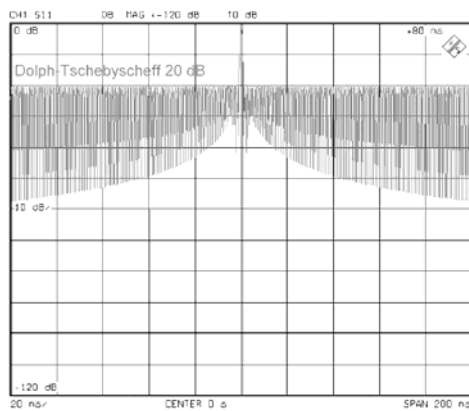
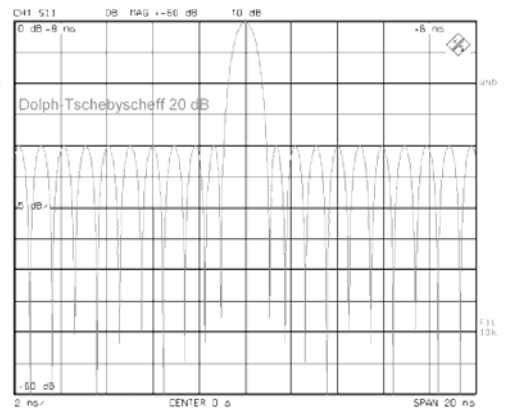
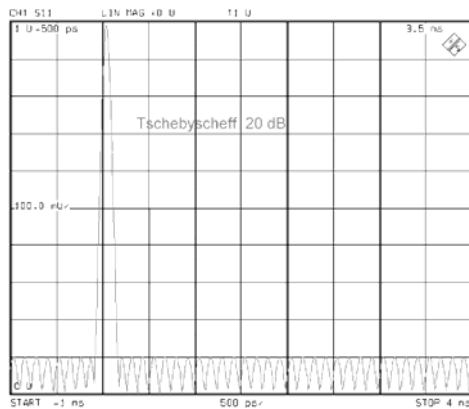


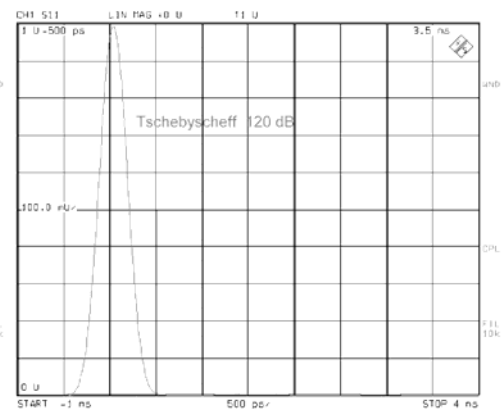
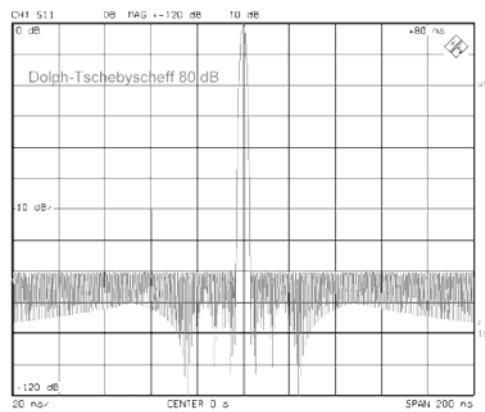
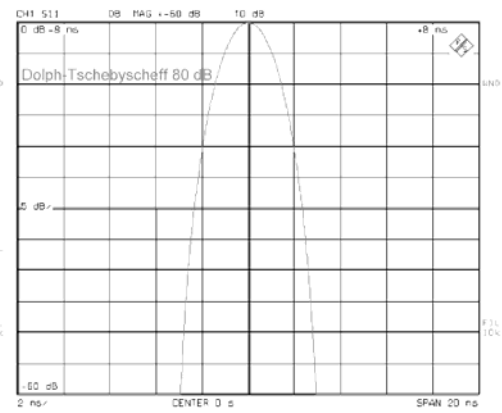
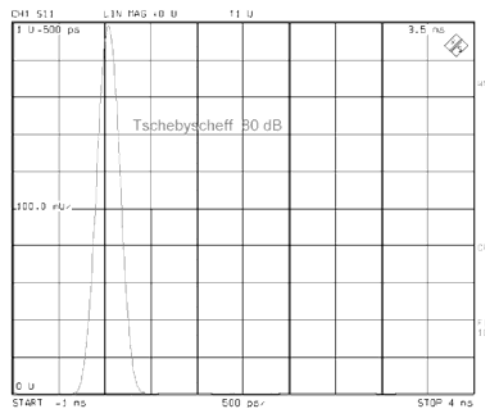
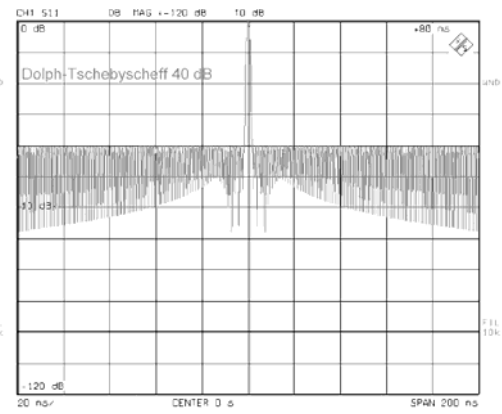
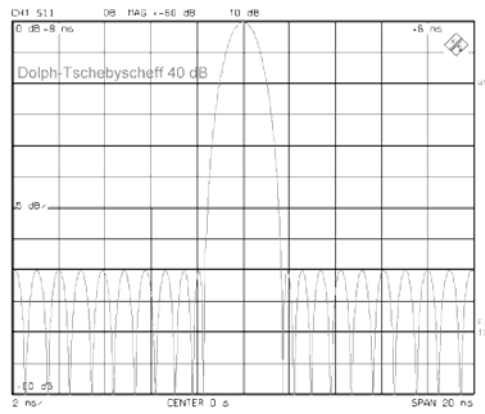
The *MAXIMUM FLATNESS* softkey switches on a gate (Bohman) of extremely flat edges. The highest sidelobe in the spectrum is 46 dB.

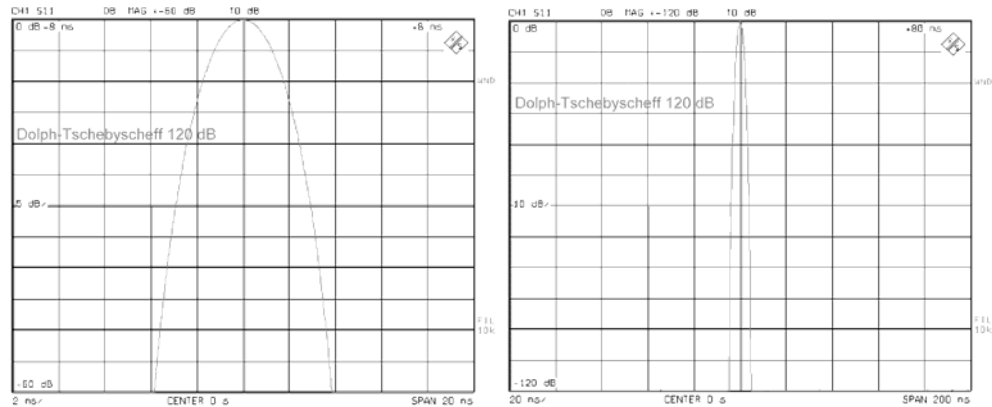




The *ARBITRARY GATE SHAPE* softkey switches on a gate (Dolph-Chebyshev) for which the suppression of the sidelobes can be user-selected. Values between 10 dB and 120 dB are permissible. Gates with low sidelobes have a wider main lobe than gates with relatively high sidelobes.







As for all other gates, the optimum solution depends on the specific measurement task. In general, a compromise must be found between either high time resolution or good signal suppression in the time domain, or between either low sidelobes or a narrow main lobe in the frequency domain.

The position of the gate is marked on the screen by means of three vertical lines. The beginning of the gate (**GATE START**) is identified by a small arrow pointing towards the right, the center of the gate (**GATE CENTER**) by a small circle and the end of the gate (**GATE STOP**) by an arrow pointing to the left. Normally, the end of the gate will be located after its beginning (with respect to time and position). In this case the gate acts as a bandpass filter, ie reflections outside the gate are suppressed.

However, the beginning of the gate can also be positioned after its end (so that the **GATE SPAN** becomes negative). In this case the gate acts as a bandstop filter.



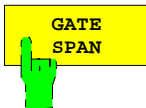
The **GATE START** softkey opens the field for entering the start time of the gate.



The **GATE STOP** softkey opens the field for entering the stop time of the gate.



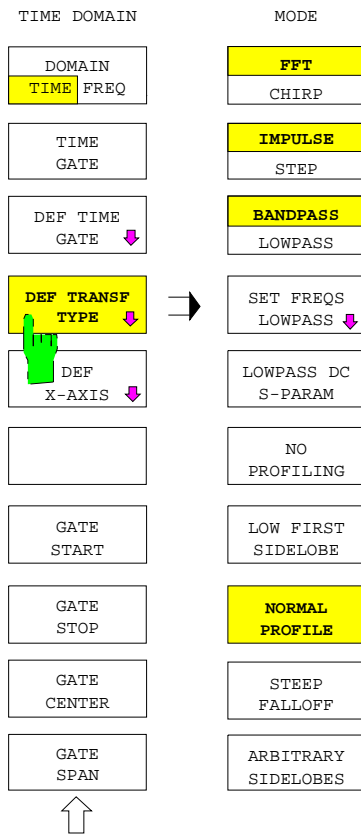
The **GATE CENTER** softkey opens the field for entering the center time of the gate. When the **DEF TIME GATE** submenu is called up, the auxiliary lines for editing the position and width of the gate are automatically activated so that the gate can be directly shifted by changing the center time (**GATE CENTER**).



The **GATE SPAN** softkey opens the field for entering the gate width.

2.4.1.1.3 Selecting the Transformation Type

SYSTEM MODE - TIME DOMAIN - DEF TRANSF TYPE submenu:



The *DEF TRANSF TYPE* softkey opens the submenu where the transformation type can be selected:

- With the first three softkeys two types of time-domain transformation (*FFT CHIRP*), impulse response or step response (*IMPULSE STEP*) and bandpass or lowpass transformation (*BANDPASS LOWPASS*) can be selected.

Any of the eight selectable combinations is permissible but not all of them are useful. (Step response is not very useful in the bandpass mode).

- In the lowpass mode, a harmonic grid is required. This can be generated by means of the function *SET FREQS LOWPASS*. The value for the S-parameter at zero frequency (*LOWPASS DC S-PARAM*) can be defined in addition.
- The lower five softkeys serve for filtering (also called weighting, profiling or windowing) the frequency-domain data.

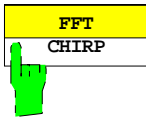
The set functions and values remain stored when the submenu is quit so that they can be re-used when the menu is recalled.

Due to the limited frequency range of the network analyzer (eg 20 kHz to 8 GHz in ZVC), not ideal (infinitely narrow Dirac) pulses but $\sin(x)/x$ pulses of finite width and ringing are obtained in the time domain.

When the frequency-domain data are filtered, which essentially means that the spectral components in the vicinity of the START and STOP frequencies are attenuated, the effect on the time-domain pulses (and analogously on the time-domain steps) can be modified. The pulse width or the height of ringing (sidelobes) can be changed. In practise, it is necessary to find an optimum compromise between the two characteristics for each application.

Various filters are available, ranging from *NO PROFILING* (corresp. to a rectangle filter), *LOW FIRST SIDELOBE* (Hamming), *NORMAL PROFILE* (Hann), *STEEP FALLOFF* (Bohman) to *ARBITRARY SIDELOBES* (Dolph-Chebichev).

The effect of each of these filters on the time-domain pulses are illustrated by the measurement diagrams inserted after the descriptions of the softkeys (see below). Basically, one can choose between narrow impulses with relatively high sidelobes (*NO PROFILING* or *ARBITRARY SIDELOBES = 10 dB*) or pulses which are wider and show very small sidelobes (eg *STEEP FALLOFF* or *ARBITRARY SIDELOBES = 120 dB*). A compromise well suited for most applications is *NORMAL PROFILE* (filter function according to Julius von Hann).



The *FFT CHIRP* softkey toggles between FFT (fast Fourier transform) and chirp transformation.

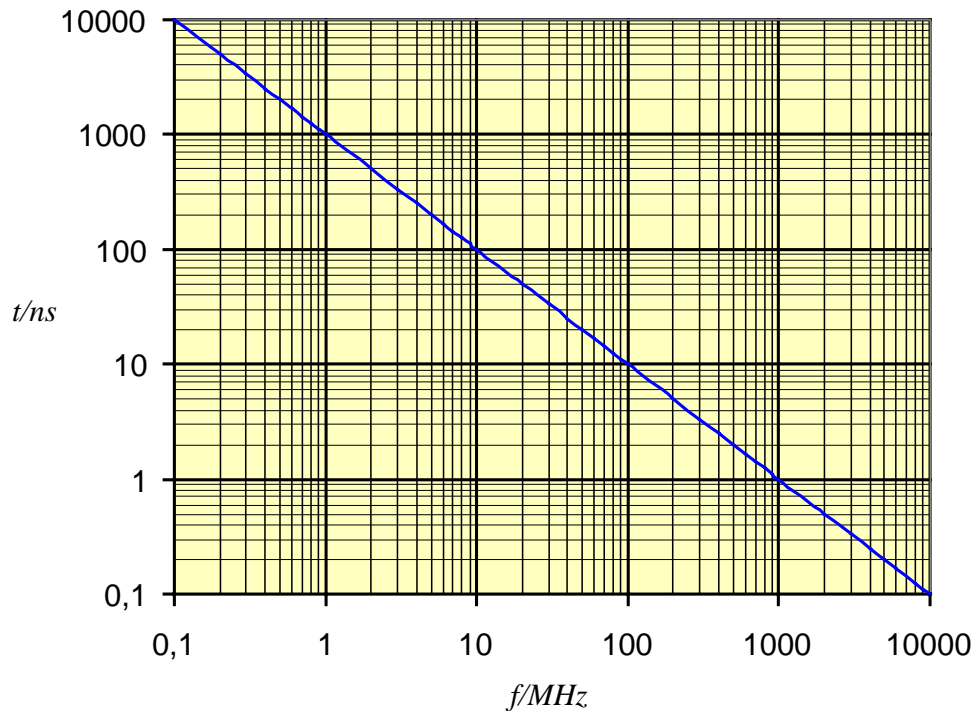
The advantage of FFT is that computation is faster than with the CHIRP transformation (by about a factor of 2). However, with FFT all measured values are equidistantly spaced over the ambiguity range (= reciprocal step width of the frequency points) in the time domain. For this reason the number of displayed values is reduced when a span narrower than the ambiguity range is displayed.

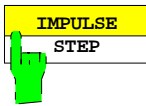
With CHIRP transformation, however, any time span can be used, and all measured values are displayed inside the (arbitrarily selectable) span. The CHIRP transformation is therefore more flexible but not as fast as the FFT.

CHIRP is the default setting.

The relationship between step width f in the frequency domain and ambiguity range t in the time domain or between frequency span f in the frequency domain and the rough (pulse) width t (corresponding to the time resolution) in the time domain is shown in the following diagram.

$$t = 1/f$$





The *IMPULSE STEP* softkey toggles between impulse response (IMPULSE) and step response (STEP).

- In the first case the response of the DUT to excitation with a short pulse is displayed. This representation is very clear and easy to interpret.
- In the second case the response of the system to excitation with a step function which in principle can be interpreted as the integral of the impulse response is displayed. The step response is particularly suitable for visualizing variations of the line impedances. To represent the step response, the LOWPASS mode (see next softkey) and not the BANDPASS mode should be used to avoid the DC component of the step response to be suppressed.

IMPULSE is the default setting.



The *BANDPASS LOWPASS* softkey toggles between the BANDPASS and LOWPASS modes.

- In the bandpass mode, arbitrary frequency steps can be used which makes operation very simple.
- In the lowpass mode, a specific frequency grid (harmonic grid) must be used. It is characterized by a START frequency which is an integer multiple of the frequency step width (see next softkey). This is the only case where the DC-component and the image spectrum at negative frequencies can be additionally used for the transformation. As a result a frequency span slightly larger than twice the span of the bandpass mode is obtained and thus the resolution in the time domain is enhanced by about a factor of 2.

BANDPASS is the default setting.

2.4.1.1.4 Defining the frequency grid

With the aid of the following submenu the frequency grid can be defined so that the START frequency f_{START} is equal to the frequency step width Δf . This is called a harmonic grid.

Definition:

The condition for a harmonic grid is $f_{START} = \Delta f$.

(The following generalized definition is often used: START frequency f_{START} should be an integer multiple of the frequency step width Δf , ie $f_{START} = n \cdot \Delta f$ where n is an integer. For network analyzers of the ZVR family the stricter definition with $n = 1$ is used.)

Example 1:

| | |
|------------------|---------|
| Number of points | = 1000 |
| START frequency | = 1 MHz |
| STOP frequency | = 1 GHz |

In this example all frequency points are integer multiples of 1 MHz. The frequency step width is 1 MHz and corresponds exactly to the START frequency. This represents a harmonic grid in the sense of the (strict) definition given above.

If, however, the following grid is selected (frequency shifted by 1 GHz compared to that of example 1),

Example 2:

| | |
|------------------|-------------|
| Number of points | = 1000 |
| START frequency | = 1.001 GHz |
| STOP frequency | = 2 GHz |

the above-mentioned strict condition for a harmonic grid is not met because the frequency step width (here also 1 MHz) is not equal to the START frequency.

Three methods are offered for automatic generation of a harmonic grid from a non-harmonic one. In all cases the number of frequency points ([SWEEP] NUMBER OF POINTS) remains unchanged.

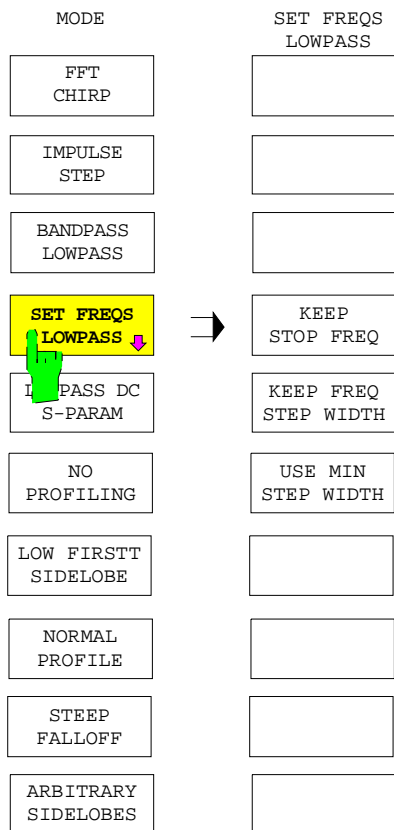
1. The START frequency is changed but the STOP frequency is kept (*KEEP STOP FREQ*). This yields the following result for Example 2: START = 2 MHz and STOP = 2 GHz.
2. Both the START and STOP frequencies are changed but the step width is kept (*KEEP FREQ STEP WIDTH*). Result for Example 2: START = 1 MHz and STOP = 1 GHz.
3. Frequency step width, START and STOP frequency are changed. The lowest possible START frequency and the lowest possible number of frequency points are set (*USE MIN STEP WIDTH*). Result for a Network Analyzer ZVC with a minimum START frequency of 20 kHz, and for Example 2: START = 20 kHz and STOP = 20 MHz.

In some cases a harmonic grid cannot be obtained under the desired conditions:

Example 3: Number of points = 1000
 START frequency = 100 kHz
 STOP frequency = 1 MHz

In example 3, the *KEEP STOP FREQ* softkey should set the START frequency to 1 kHz. This may not be possible for some analyzer models and configurations (eg for a ZVC with a minimum frequency of 20 kHz). In such cases the analyzer outputs a warning to this effect.

SYSTEM MODE - TIME DOMAIN - DEF TRANSF TYPE - SET FREQS LOWPASS submenu



The *SET FREQS LOWPASS* softkey opens the submenu for determining the harmonic frequency grid required for the lowpass mode: A harmonic grid can be obtained in different ways:

- The START frequency is changed, the STOP frequency remains the same (*KEEP STOP FREQ*).
- START and STOP frequency are changed, the frequency step width remains the same (*KEEP FREQ STEP WIDTH*)
- START and STOP frequency and the frequency step width are changed. The START frequency and step width are minimized (*USE MIN STEP WIDTH*).



The *KEEP STOP FREQ* sets a harmonic frequency grid; the number of frequencies and the STOP frequency remain unchanged. To obtain a harmonic grid, the START frequency and thus the frequency step width are suitably modified (as far as possible). If this is not possible (see explanations above), a message is displayed to this effect.

This method is recommended for most applications.



The *KEEP FREQ STEP WIDTH* sets a harmonic frequency grid; the number of frequencies and the step width remain unchanged. To obtain a harmonic grid, the START and STOP frequencies are suitably modified (as far as possible). If this is not possible (see explanations above), a message is displayed to this effect.



The *USE MIN STEP WIDTH* sets the harmonic frequency grid with a minimum step width. This is always possible.

For measurements with high accuracy requirements, a system error calibration should be performed **after** setting the harmonic grid (enhancement label CAL is on during measurements in the LOWPASS mode).

SYSTEM MODE - TIME DOMAIN - DEF TRANSF TYPE submenu:



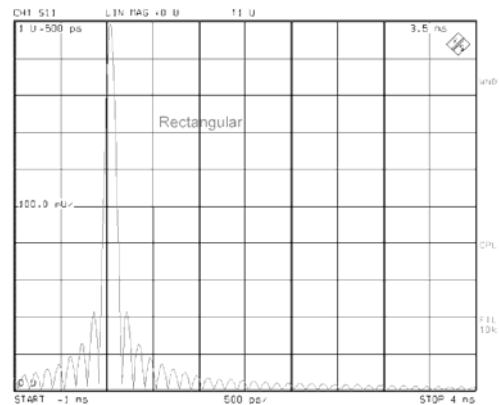
Softkey *LOWPASS DC S-PARAM* enters a (measured or estimated) S-parameter of the DUT, which is valid at zero frequency. This parameter is required to obtain a correct amplitude offset for the step response in the lowpass mode.

The standard setting for this value is 1. This means full transmission ($S_{21}=S_{12}=1$) when measuring transmission or total reflection with phase zero corresponding to an open circuit ($S_{11}=S_{22}=1$) when measuring reflection.



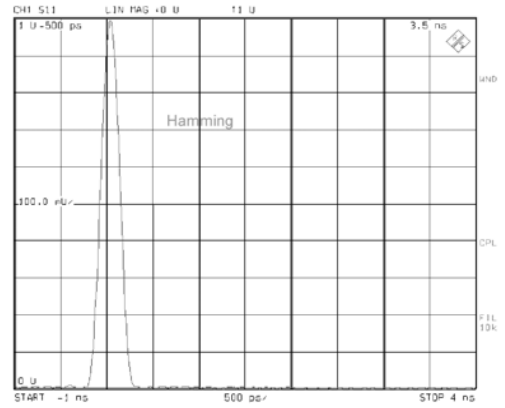
Softkey *NO PROFILING* leaves the frequency domain data as measured by the network analyzer.

This corresponds to a rectangular filtering of (fictitious) data of an originally infinitely wide frequency range. As a consequence, relatively narrow pulses are obtained in the time domain but with considerable ringing (sidelobes).

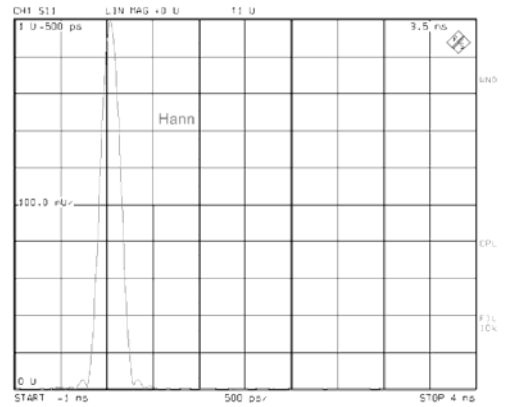




The *LOW FIRST SIDELOBE* softkey activates a Hamming filter. This filter especially suppresses the first sidelobe and is therefore particularly suitable for the detection of closely spaced faults.



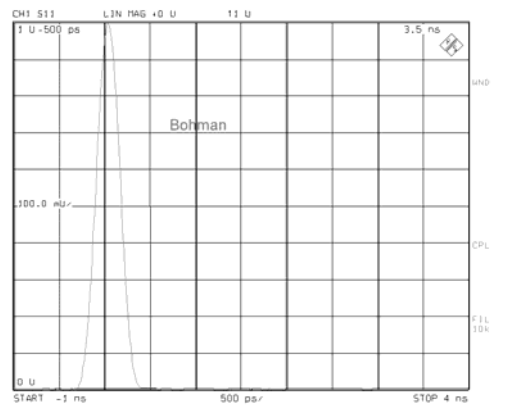
The *NORMAL PROFILE* softkey activates the Hann filter also called Hanning. This is a good compromise between pulse width and sidelobe suppression.

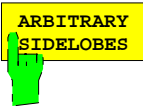


This filter is recommended for general applications.

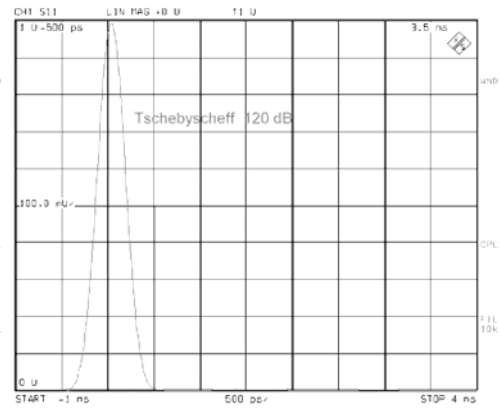
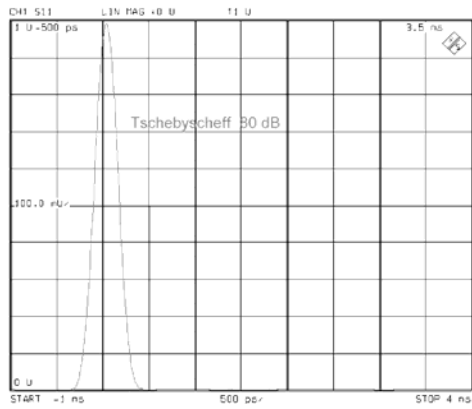
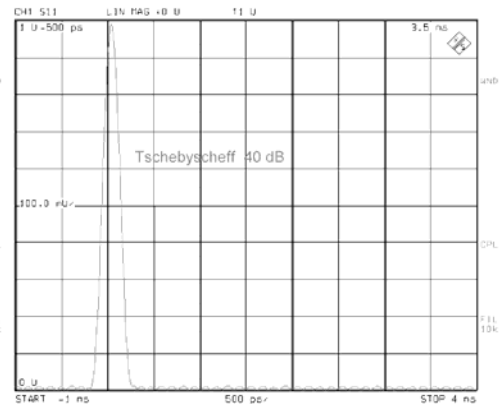
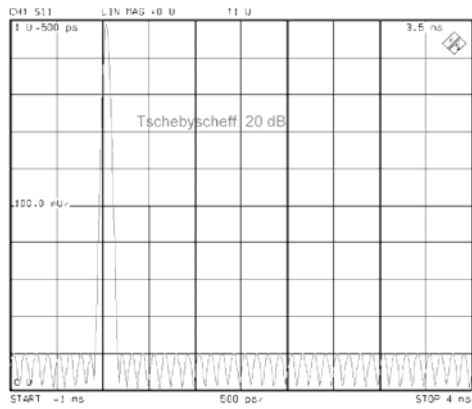


The *STEEP FALLOFF* softkey activates a Bohman filter which causes a particularly steep roll-off of sidelobes. This filter is especially suitable when a far off but relatively low reflection occurs besides a large reflection.



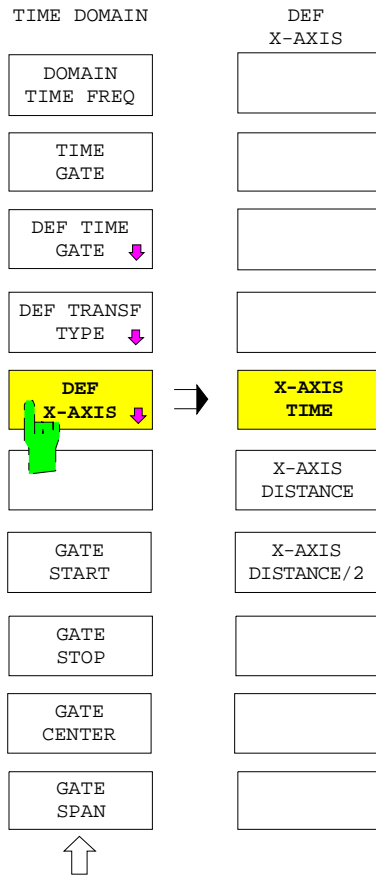


The *ARBITRARY SIDELOBES* softkey activates a Chebichev filter. In this case the sidelobe suppression can be arbitrarily set to values between 10 dB and 120 dB.



2.4.1.1.5 Scaling the Abscissa

SYSTEM MODE - TIME DOMAIN - DEF TRANSF TYPE submenu:



The *DEF X-AXIS* softkey opens the submenu for scaling the abscissa. Scaling parameters are

- delay time (*X-AXIS TIME*),
- distance (*X-AXIS DISTANCE*),
- half the distance (*X-AXIS DISTANCE*),

The set scale is stored when the submenu is quit.



The *X-AXIS TIME* softkey scales the abscissa with respect to the delay time.

This is the default setting.



The *X-AXIS DISTANCE* softkey scales the abscissa with respect to the distance. This is particularly useful when measuring electrical lengths via the transmission.

With transmission measurements in air, a delay time of 1 ns corresponds to a distance of approx. 299.7 mm (corresponding to the velocity of light of $c \approx 299.7$ mm/ns). A pulse delayed by 1 ns is therefore displayed at the position 299.7 mm.

With other transmission media, the effect of the dielectric on the velocity of light can be taken into account with the aid of the *SET DIELECTRIC* table. For example, compared to the vacuum, the velocity of light is divided by two in a medium with a permittivity of $\epsilon=4$. In this case a pulse delayed by 1 ns should be about at the position 149.9 mm.



The *X-AXIS DISTANCE/2* softkey scales the abscissa with respect to half the distance. This is particularly suitable for displaying the distance in the case of reflection measurements.

When measuring the reflection (for instance on an open ended cable), the pulse travels through the cable twice before it is received, ie to the end of the cable where it is reflected and then back again. The delay time therefore corresponds to twice the cable length. For reflection measurements, the delay in a line (filled with air) of 299.7 mm length is therefore 2 ns (instead of 1 ns as for transmission measurements). With *X-AXIS DISTANCE* selected, the pulse delayed by 2 ns would be displayed at 599.4 mm. This scaling (*X-AXIS DISTANCE/2*) should be selected to obtain the desired distance of 299.7 mm.

2.4.1.1.6 Positioning the Gate

The position of the gate is marked on the screen by means of three vertical lines. The beginning of the gate (*GATE START*) is identified by a small arrow pointing towards the right, the center of the gate (*GATE CENTER*) by a small circle and the end of the gate (*GATE STOP*) by an arrow pointing to the left. Normally, the end of the gate will be located after its beginning (with respect to time and space). In this case the gate acts as a bandpass filter, ie reflections outside the gate are suppressed.

However, the beginning of the gate can also be positioned after its end (so that the *GATE SPAN* becomes negative). In this case the gate acts as a bandstop filter.

SYSTEM MODE - TIME DOMAIN:



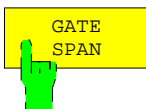
The *GATE START* softkey opens the field for entering the start time of the gate.



The *GATE STOP* softkey opens the field for entering the stop time of the gate.



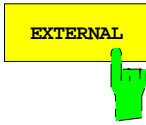
The *GATE CENTER* softkey opens the field for entering the center time of the gate. When the *TIME DOMAIN* menu is called up this function is automatically activated so that the position of the gate can be shifted directly.



The *GATE SPAN* softkey opens the field for entering the gate width.

2.4.1.2 External Measurements

SYSTEM MODE menu:



The *EXTERNAL* softkey activates the external measuring mode. It is available on models ZVR, ZVRE, ZVRL, ZVC and ZVCE. Option ZVR-B25 External Measurements is installed.

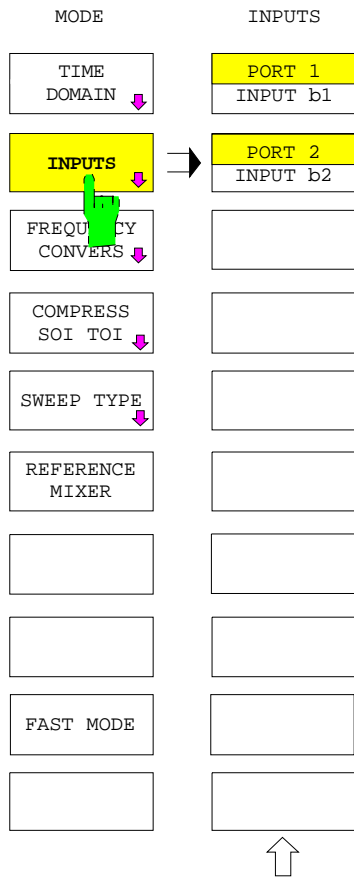
The default setting of this softkey is disabled. *EXTERNAL* active is indicated by the enhancement label EXT.

The effects of the *EXTERNAL* softkey are global, i.e. valid for all display channels (also see *SWEEP - COUPLED CHANNELS*).

In the *EXTERNAL* mode, the internal test set (PORT 1 and PORT 2 females), the bridges of which have a model-dependent lower cutoff frequency, is bypassed. Therefore the entire frequency range of the generator and the receiver (from 10 Hz to 4 GHz for ZVR, ZVRE and ZVRL; from 20 kHz to 8 GHz for ZVC and ZVCE) may be used. The output of the test signal source is switched to the OUTPUT a1 socket, INPUT b1 and INPUT b2 are available for inputs.

Since only the outgoing wave a is available with OUTPUT a1, only the forward parameters S_{11} and S_{21} can be measured in the external mode. It is, however, possible to redefine the latter via the *MEAS - USER DEF'D S PARAMS* menu in order to offer utmost flexibility for the user with configuration of an external test setup. Note that the definition of S-parameters as in the table *USER DEFINED S-PARAMETERS* is valid for external operation.

Switching the external operating mode on and off results in different operating ranges for the frequency and level of the internal signal source. If the frequency or the level settings are adapted to the new range, a message will be displayed.

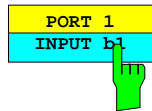


On a ZVK and ZVM, the INPUTS softkey appears in place of the EXTERNAL softkey provided at least one receiver attenuator is installed.

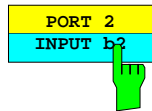
In the INPUTS menu, the user can select for each receiver attenuators installed whether the signal to be measured is to be fed via the test port or the INPUT connector. Similar to option ZVR-B25 (see softkey EXTERNAL), this allows external signal separating devices (eg couplers) to be connected. However, this does not entail a frequency extension.

If at least one of the INPUT connectors is active, this is indicated by the EXT status.

It should be noted that in contrast to ZVRx and ZVCx, ZVK and ZVM do not automatically adopt the user-defined S-parameters when an INPUT is activated. For user-defined S-parameters, the USER DEF ACTIVE softkey in the menu MEAS-USER DEF'D S-PARAMS is used.



The softkey *PORT 1 INPUT b1* serves for switching between the test port PORT 1 and the connector INPUT b1 as input for the wave quantity. This softkey is available only if option ZVM-B23/ZVK-B23 (receiver attenuator for ZVM/ZVK PORT 1) is installed.

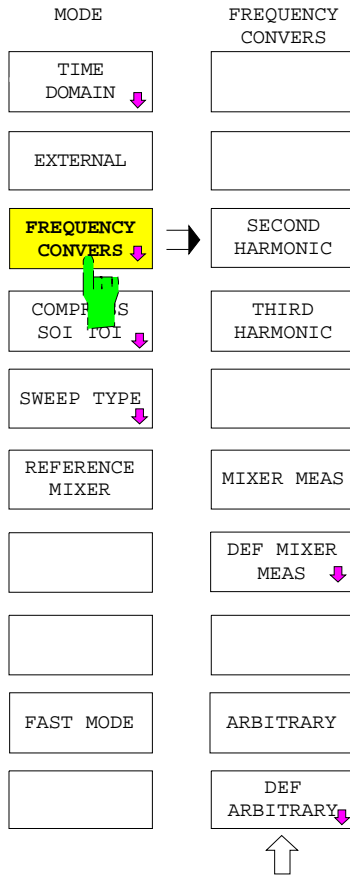


The softkey *PORT 2 INPUT b2* serves for switching between the test port PORT 2 and the connector INPUT b2 as input for the wave quantity. This softkey is available only if option ZVM-B24/ZVK-B24 (receiver attenuator for ZVM/ZVK PORT 2) is installed.

2.4.1.3 Measurements on Frequency-Converting DUTs (Option ZVR-B4)

The option ZVR-B4, "Mixer Measurements" enables measurements on frequency-converting components such as mixers or multipliers.

SYSTEM MODE - FREQUENCY CONVERTERS submenu:



The *FREQUENCY CONVERTERS* softkey opens the submenu that activates, deactivates and configures frequency-converting measurements. The type of the frequency conversion is defined relative to a **base frequency**.

In a frequency sweep (*SWEEP TYPE - FREQUENCY SWEEP*), the base frequency and its sweep range is set via the *STIMULUS* key block or the *SWEEP - DEF SWEEP LIST* softkey.

If, however, *SWEEP TYPE - POWER SWEEP* or *TIME SWEEP* is active, the base frequency is defined as a constant parameter via the *SWEEP SOURCE - FREQUENCY* softkey.

- The measurement of the second and third harmonic is selected directly, i.e. without any configuration setting.
- Mixer measurements are defined in a special submenu (*DEF MIXER MEAS*).
- Another submenu is provided for configuration of general frequency-converting measurements (*ARBITRARY*) allowing for test setups which may for example contain several mixer stages, multipliers or dividers (*DEF ARBITRARY*).

Notes:

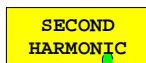
- In the frequency-converting mode, the *S* parameters are not defined and the ratios of measured wave quantities are ill-defined unless the numerator and denominator waves have the same frequency. This is because the ZVx analyzer family's measurement and reference channels can only be tuned to a single, common receive frequency. For general frequency-converting measurements, *CONV GAIN b1/Pa1* or *CONV GAIN b2/Pa1* are available as a universal quantity referred to a reference. For conversion gain, there is a measured wave quantity in the numerator; the denominator, however, is not a measured quantity but the nominal generator power of the analyzer. When a frequency-converting measurement is activated, *CONV GAIN b2/Pa1* is automatically selected as the measured quantity.
- External conversion is required if any rational quantity associated with waves of different frequencies has to be measured (see section 2.4.1.6).
- It is best to perform power calibration at the source port and load port to obtain an accurate measurement of the conversion gain or loss. An appropriate test-point grid should be selected for this calibration procedure (*CAL CAL - START POWER CAL*, see section 2.15.1.4).
- The frequency-converting mode supports the usual applications where the generator and receive frequencies differ and some special measurement tasks. *S* parameters can be measured, for example, if the generator and receive frequencies are the same, and an external generator that supplies an auxiliary signal can also be controlled. Even if *CONV GAIN b2/Pa1* is automatically set

after activating the frequency-converting mode, the whole range of quantities can be selected with the MEAS key. Even a system-error correction can be activated in the ARBITRARY mode. It is the user who decides whether a selected quantity is useful or not in the current setting.

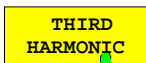
- If MIXER MEAS or ARBITRARY is activated, the new frequency ranges are subjected to permissibility checks after any entry which modifies the frequency range of the internal or of an external signal source or of the receiver. Likewise, a check is made to determine whether the new generator covers the frequency range set for it after an external generator type has been modified in the EXT SRC CONFIG table. If the network analyzer detects overranging, the frequency-converting measurement is turned off automatically and an appropriate warning is displayed. If the user edits the DEF MIXER MEAS or DEF ARBITRARY menus without activating the associated frequency-converting mode, only warnings are displayed (on quitting the menu in the case of DEF ARBITRARY).
- With decoupled display channels (SWEEP SWEEP - COUPLED CHANNELS deactivated), frequency conversion can be individually defined for each channel.
- Frequency-converting modes can only be activated if an intercept measurement is not being performed at the same time.

2.4.1.3.1 Harmonics Measurements

SYSTEM MODE - FREQUENCY CONVERTS submenu:



The *SECOND HARMONIC* softkey activates the measurement of the second harmonic of the internal signal source. This mode is indicated by the enhancement label $H = 2$.



The *THIRD HARMONIC* softkey activates the measurement of the third harmonic of the internal signal source. This mode is indicated by the enhancement label $H = 3$.

In both cases the frequency of the internal signal source serves as the base frequency (see page 2.117). The receiver frequency is twice or three times the base frequency. If the allowed frequency range of the receiver is exceeded in the harmonic measurement mode, the base frequency is reduced as much as necessary.

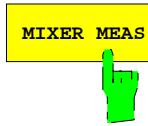
Higher-order harmonics can be measured in the *ARBITRARY* mode.

Note:

- To measure the efficiency of a multiplier, connect the input of the DUT to the source port and its output to the load port of the analyzer. Select MEAS – RATIO - CONV GAIN $b2/Pa1$ as a test parameter.
- To measure harmonics suppression of a signal, apply the signal to the load port (receiver input) and measure the fundamental wave (eg MEAS – WAVE QUANTITY – $b2$). Store the trace with TRACE – DATA TO MEMORY and select the mathematical linkage (SHOW MATH) for display (active function: MATH = DATA/MEM). Start the harmonics measurement. The suppression of the harmonic in question will be displayed directly.

2.4.1.3.2 Mixer Measurements

SYSTEM MODE - FREQUENCY CONVERTERS submenu:



The softkey *MIXER MEAS* activates the mixer measurement mode. This operating mode is indicated by the enhancement label MIX.

This measurement mode can be configured via the *DEF MIXER MEAS* menu.

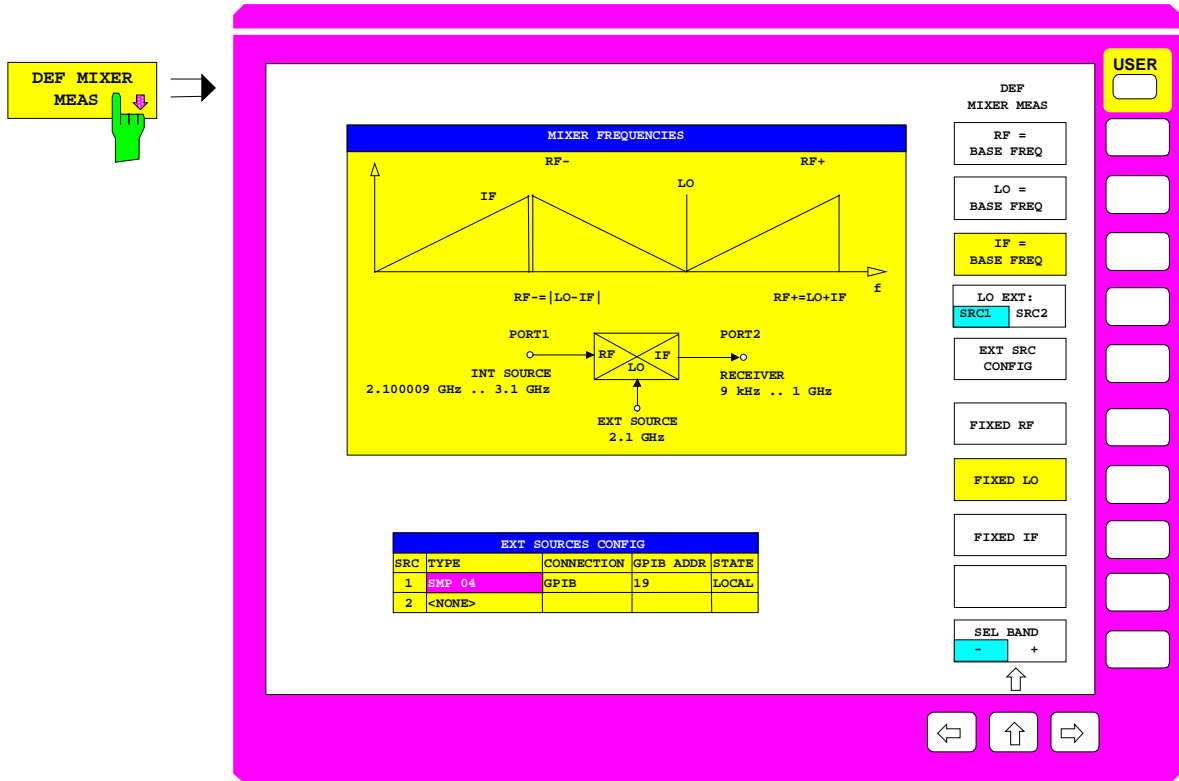


Fig. 2-21 Configuration of mixer measurements - *DEF MIXER MEAS* menu

The *DEF MIXER MEAS* softkey calls the menu provided for configuration of mixer measurements.

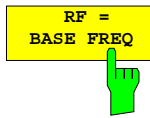
In contrast to the general frequency conversion (see below, softkey *DEF ARBITRARY*), the test setup can not be freely selected but is predefined:

- The internal signal generator supplies the RF signal,
- an external source serves as local oscillator (LO),
- The intermediate frequency (IF), which results from the difference between the RF frequency and the local oscillator frequency, is measured.

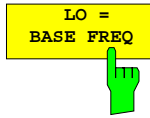
Mixer measurements can be performed in internal and external mode.

Each one of the three mixer frequencies RF, LO and IF can be declared as the base frequency. A sweep will then be performed according to the setting in the *STIMULUS* key group or the active sweep list. One of the two remaining frequencies is maintained at a user-definable constant value. The other one results from the correlation $IF = |RF - LO|$. A graph is provided to help the user in his choice of one of the two bands in those cases where the sign is ambiguous (for an example, see Fig. 2-21 where RF is calculated from IF and LO).

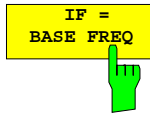
SYSTEM MODE - FREQUENCY CONVERTERS - DEF MIXER MEAS submenu:



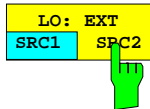
The *RF = BASE FREQ*, *LO = BASE FREQ* and *IF = BASE FREQ* softkeys specify which one of the three mixer frequencies should serve as a base frequency (see page 2.117).



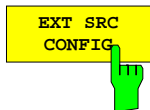
If a mixer frequency which was previously defined as fixed (see below, softkeys *FIXED RF*, *FIXED LO*, and *FIXED IF*) is set to be the base frequency, the analyzer sets another mixer signal to a fixed frequency.



- In general, the LO frequency is set to a fixed value (*FIXED LO*).
- However, when *FIXED LO* is active and the frequency of the local oscillator is set to be the base frequency (*LO = BASE FREQ* is selected), the system switches to *FIXED IF*.



The *LO: EXT SRC1 SRC2* softkey selects one of the two external signal sources *SRC1* or *SRC2* as local oscillator. *SRC1* is the default setting.



The *EXT SRC CONFIG* softkey activates the *EXT SOURCES CONFIG* table.

| EXT SOURCES CONFIG | | | | |
|--------------------|--------|------------|-----------|-------|
| SRC | TYPE | CONNECTION | GPIB ADDR | STATE |
| 1 | SMP 04 | GPIB | 19 | LOCAL |
| 2 | <NONE> | | | |

The *EXT SOURCES CONFIG* table configures the external source. The table is displayed on calling the *DEFINE MIXER MEAS* menu and has five columns, four of which can be edited:

SRC – number of the external generator (can not be edited)

TYPE – generator type

The *TYPE* field specifies the type of external generator used. The default type is *<NONE>* denoting that the external generator is configured manually. In this case the softkeys *LO = BASE FREQ*, *FIXED RF* and *FIXED IF* can not be used.

The *EXT SRC TYPE* selection table is displayed when the field is edited.

| EXT SRC TYPE |
|--------------|
| SME02 |
| SME03 |
| SME06 |
| SMG |
| SMGL |
| SMGU |
| SMH |
| SMHU |
| SMIQ02 |

CONNECTION – Remote control mode of the external source

The default mode for all generator types except <NONE> is *CONNECTION = GPIB*. That means, if the generator is remote-controlled (*STATE = REMOTE*), the frequency and signal level is set via IEEE-bus before each test point.

In addition, some generator types are equipped with the accelerated mode *GPIB + TTL*. In this mode, the generator first receives a list of all frequency points (with level information) to be set during the sweep. This list is transferred via IEEE-bus. When the sweep is performed, the only thing to do is to switch the generator from one point to the next by means of a TTL control signal. For this hardware handshake, the signals BLANK and TRIGGER at the rear of the analyzer (see Annex A.11) must be connected with the sockets of the same name of the external generator. Newer generators contain these signals in a multi-point connector. *CONNECTION = GPIB + TTL* can be used for one of the two external generators only.

GPIB ADDR – IEEE-bus address of the external source

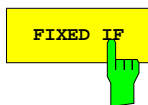
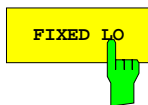
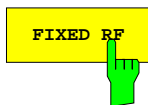
In this column the IEEE-bus address of the external source is set (in the range between 0 and 31). The address must be unique, i.e. two devices with the same address must not be connected to the IEEE-bus.

STATE – Switching the remote control on and off

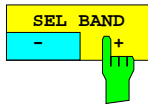
The *STATE* field is used to toggle between manual (*LOCAL*) and remote control (*REMOTE*) of the instrument. In operating modes with swept LO, *STATE = REMOTE* must be set. The default setting, which can be restored by means of *PRESET*, is *LOCAL*.

Note: A swept external source which is part of an active measurement configuration can not be set to the *LOCAL* state.

SYSTEM MODE - FREQUENCY CONVERS - DEF MIXER MEAS submenu:



The *FIXED RF*, *FIXED LO* and *FIXED IF* softkeys keep the corresponding mixer frequency at a constant value and activate an entry field for this frequency value. All three softkeys act on the same frequency value. The default setting is *FIXED LO* active, the smallest possible frequency of the currently selected external source serving as fixed frequency.



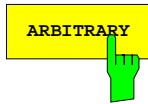
The *SEL BAND* softkey selects the band for the third mixer frequency in cases where the sign is ambiguous. The default setting is "-".

As soon as two of the three mixer frequencies have been defined by assigning the base frequency (softkeys *RF*, *LO*, *IF = BASE FREQ*) and the fixed frequency (softkeys *FIXED RF*, *LO*, *IF*), the third frequency is given by the formula $IF = |RF - LO|$. Resolving the absolute value might, however, imply a sign ambiguity.

A graph which illustrates the relative position of the three mixer frequencies makes it easier to choose the desired band (see Fig. 2-20) if the third frequency is ambiguous. Bands containing the frequency 0 Hz appear as "folded" around the origin in the graph and can not be selected. Analogously, bands which exceed the allowed frequency range can not be selected either. Such bands are labeled as „not available". If only one of the two bands is not available, the other one is selected automatically and the state of the softkey is fixed. If the frequencies are such that none of the bands is available, the softkey can not be used.

2.4.1.3.3 Arbitrary Frequency Conversion

SYSTEM MODE - FREQUENCY CONVERS submenu:



The *ARBITRARY* softkey activates the frequency configuration defined via *DEF ARBITRARY*. The enhancement label *ARB* is displayed whenever this operating mode is active.



The screenshot shows the configuration interface for arbitrary system frequencies. It includes two main tables and several control elements.

DEF ARBITRARY

DEF ARBITRARY
 ARBITRARY
 SYST FREQ

EXT SRC CONFIG

ARBITRARY SYSTEM FREQUENCIES

BASE FREQUENCY: 2GHz ... 3GHz

| | ON | POWER | (NUM / DEN)xB | + OFFSET | RESULT |
|----------|----|--------|---------------|----------|--------------------|
| INT SRC | ✓ | 0 dBm | (1 / 1) | xB | 2GHz..3GHz |
| EXT SRC1 | ✓ | 10 dBm | (1 / 1) | +205MHz | 2.205GHz..3.205GHz |
| EXT SRC2 | | | | | |
| RECEIVER | ✓ | | | 205MHz | 205MHz |

STIMULUS AXIS: BASE FREQUENCY 2GHz..3GHz

EXT SOURCES CONFIG

| SRC | TYPE | CONNECTION | GPIB ADDR | STATE |
|-----|--------|------------|-----------|--------|
| 1 | SMP04 | GPIB | 19 | REMOTE |
| 2 | <NONE> | | | |

USER

Navigation buttons: Back, Up, Right

Fig. 2-22 Configuration of system frequencies

The *DEF ARBITRARY* softkey calls the *ARBITRARY SYSTEM FREQUENCIES* table.

The table allows to describe complex test setups, which contain various mixers (including harmonic mixers), frequency multipliers or dividers. The frequency of the internal signal source, of the receiver or of up to two external sources can be derived from the base frequency (named B in this case) using a user-definable linear equation.

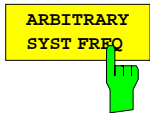
Note: When editing the frequency equations, make sure that the configuration corresponds to the physical test setup. Otherwise no signal will be received.

System-error correction can be activated in the *ARBITRARY* mode (*CAL – UNCAL* softkey). This is important when S parameters are to be measured and an auxiliary signal is required. For example, the user may perform a simultaneous sweep with a frequency-offset external generator to operate the DUT in its large-signal range. Furthermore, it is possible to select whether the system-error correction data is to be interpolated or not (*CAL - CAL INTERPOL* softkey). It should be noted that system-error correction gives spurious results if the generator and receive frequencies are not the same.

In the *DEF ARBITRARY* menu the base frequency B may be selected outside the limits which usually apply to the network analyzer even when *ARBITRARY* is active. However, the frequency limits for the internal and external sources and for the receiver must be observed (cf. description of the *FREQUENCY CONVERS* menu). In contrast to the mixer measurement, external sources that are activated in the *ARBITRARY SYSTEM FREQUENCIES* table (ticked in the ON column) should always be remote-controllable, i.e. *STATE = REMOTE* has to be set in the *EXT SOURCES CONFIG* table.

Together with the *EXT SOURCES CONFIG* table, the *ARBITRARY SYSTEM FREQUENCIES* table and two softkeys for switching over between the two tables are displayed.

SYSTEM MODE - FREQUENCY CONVERS - ARBITRARY SYST FREQ Submenu:



The *ARBITRARY SYST FREQ* softkey selects the *ARBITRARY SYSTEM FREQUENCIES* table for editing purposes. This is the default setting when the menu is called.

This table allows to define all four frequencies *f* (internal source, external sources 1 and 2 and receiver) via the coefficients of a linear equation of the type

$$f_i = (NUM_i / DEN_i) \times \text{base frequency } B + OFFSET_i, \quad i = 1 \dots 4$$

The first line in the table displays the base frequency (*BASE FREQUENCY*). This frequency is defined by means of the *START / STOP* or *CENTER / SPAN* key of the *STIMULUS* keypad. If frequency axis segmentation has been activated with *SWEEP SWEEP – SEG SWEEP*, this is indicated by the additional entry *SEGMENTED*. If the base frequency is to be a CW signal, the setting is performed via *SWEEP SWEEP – SINGLE POINT* and *STIMULUS CENTER* (frequency value).

The lines *INT SRC*, *EXT SRC 1*, *EXT SRC 2* and *RECEIVER* following the table header are used to configure the system frequency, which is derived from the *BASE FREQUENCY* with the aid of the above formula. The resulting sweep range is displayed in the *RESULT* field.

The last line, *STIMULUS AXIS*, allows a system frequency other than the base frequency to be selected for scaling the sweep axis of the measurement diagram. A table of admissible system frequencies can be opened via the center field of this line. This table contains at least the entries *BASE FREQUENCY* (= default setting) and *RECEIVER*. Furthermore, the system frequency activated in the corresponding *ON* field is offered.

Note: All frequency entries for *STIMULUS* and *MARKER* are always referred to the base frequency (*BASE FREQUENCY*) - even if something else is selected as the *STIMULUS AXIS*. In the latter case, an appropriate message is displayed in the frequency entry field.

The *ARBITRARY SYSTEM FREQUENCIES* table contains the following columns (all but the first and the last (*RESULT*) can be edited):

System frequency

The first column indicates the system frequency. Either the internal source (*INT SRC*), external sources (*EXT SRC*) 1 and 2, receiver (*RECEIVER*) can be configured.

ON – on/off switch for the external sources

A checkmark indicates the switched-on state. All three sources can be switched on or off. The receiver remains always switched on. If an external source is switched on, *ARBITRARY* can be activated only if the source was configured as *REMOTE* in the *EXT SOURCES CONFIG* list.

POWER – source power

The output power of the signal source can be set in the *POWER* column. Usually – i.e. without generator power calibration – the power can be varied in the same way as via the softkeys *SOURCE – POWER* (for the internal source) or *SOURCE – EXT SRC 1, 2 POWER* (for external sources).

If a generator power calibration of the internal waves a_1 or a_2 is active, however, the field is coupled with the softkeys *CAL a1 POWER* or *CAL a2 POWER* in the menus *SOURCE* and *CAL – START NEW POWER CAL*. Analogously, if power calibration of an external source is active, the field is coupled with the softkeys *CAL EXT SRC 1/2 POWER* in the same menus. The receiver power can not be set.

NUM – numerator

Integer numerator of the multiplier for the base frequency.

DEN – denominator

Integer denominator of the multiplier for the base frequency.

xB – on/off switch for the linear term in the equation

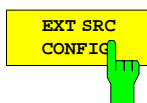
In the *on* state, the multiplier defined by NUM/DEN is multiplied by the base frequency B and added to the *OFFSET*. If *MODE – SWEEP TYPE – FREQUENCY SWEEP* is switched on, the base frequency B and therefore the derived system frequency is swept. In the *off* state of x_B , the term proportional to B is dropped and the constant *OFFSET* is effective only (CW mode).

OFFSET – additive frequency offset

Each system frequency can be shifted by means of an individual, constant offset frequency with positive or negative sign. If the x_B field is deactivated, the system frequency in question is in the CW mode.

RESULT – resulting frequency range

This field can not be edited. For a frequency sweep it indicates the sweep range for the corresponding system frequency defined by the linear equation; otherwise, it contains the corresponding CW frequency. As only positive frequencies can occur in practice, the analyzer always returns the absolute value of the result of the equation.

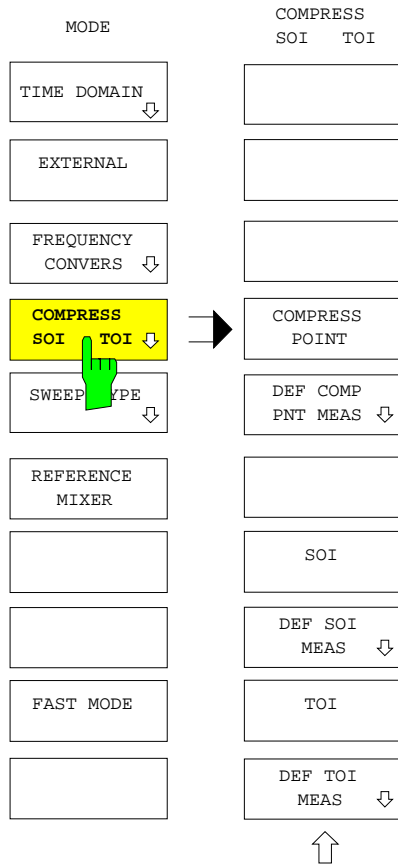


The *EXT SRC CONFIG* softkey selects the *EXT SOURCES CONFIG* table for editing purposes.

The description of the *FREQUENCY CONVERS - DEF MIXER MEAS* softkey explains how to handle this table.

2.4.1.4 Nonlinear Measurements (Option ZVR-B5)

SYSTEM MODE - COMPRESS SOI TOI submenu:



The *COMPRESS SOI TOI* softkey opens the menu providing operating modes used to determine quantities describing the nonlinear features of a DUT. These operating modes require the option "Nonlinear Measurements" (ZVR-B5).

- The X-dB compression point (*COMPRESS POINT*) represents the signal level at which the S-parameter or ratio selected as a measured quantity has been reduced by X dB compared to its small-signal value due to a increasing saturation of the DUT. It corresponds to the upper limit of the level range where behavior of the DUT can be considered as linear (with an allowed deviation of X dB at maximum, softkeys *COMPRESS POINT* and *DEF COMP PNT MEAS*).
- When a two-tone signal is applied to a DUT, the n^{th} order intercept is defined as the level at which the n^{th} order intermodulation product generated by the DUT and the fundamental waves are at the same level. In practice the 3^{rd} order intercept point is of particular importance. It describes intermodulation products located close to the fundamental waves (e.g. in an adjacent channel). The 3^{rd} order intercept is also referred to as TOI or IP3.

The NWA can be also used to determine the SOI (= second order intercept) or IP2. At least one external generator is required to determine the SOI or TOI (softkeys *SOI*, *TOI*, *DEF SOI/TOI MEAS*).

Notes:

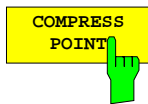
- Nonlinear measurements can be activated only in a frequency sweep (SYSTEM MODE - SWEEP TYPE - FREQUENCY SWEEP) and if no frequency-conversion mode is switched on.
- Compression point and intercept measurements are both based upon iterative algorithms where a primary quantity is measured at several generator levels and receiver frequencies. For the compression point measurement, the primary quantity is the S-parameter or a ratio (MEAS – RATIO menu). For the intercept measurement, an absolute level, i.e. a wave quantity (MEAS – INPUT menu), is measured.
- Even for a non-linear measurement the active system error or power correction is still applied to the primary measured quantity. This is of crucial importance for the accuracy of compression point and intercept measurements because level deviations of the sources used and of the receivers have a direct impact on the result. Especially for the intercept measurement where both generator signals must be combined before the input of the DUT by means of the level adder or coupler, it is recommendable to perform a power calibration (CAL CAL - START POWER CAL) at the reference planes of the DUT before starting the measurement.
- The measurement algorithms check whether the behavior of the DUT corresponds to the model the measured nonlinear quantity is based on. They validate, e.g., whether an increase of the input level causes compression at all or whether the level of the 3^{rd} order intermodulation product shows a cubic behavior. If one of these plausibility checks fails, a specific default value is returned. To be recognizable at a glance, default values differ much from realistic measurement values (≥ 100 dBm or ≤ -100 dBm). The failure of a plausibility check is not necessarily due to the DUT, it may be as well due to errors in the test setup or in the calibration. A list of possible default values can be retrieved by

means of the *CHK VALUE SETTINGS* softkey in the *DEF COMP PNT MEAS* and *DEF SOI / TOI MEAS* menus. The different checks may be activated or deactivated individually.

- For nonlinear measurements, one is restricted to the electronically adjustable level range of the internal signal generators. Step attenuators are not automatically set.
- As the number of single measurements at each point of the sweep is not known a priori, the sweep time can not be set, i.e. the softkeys *SWEEP – SWEEP TIME AUTO MAN* and *EDIT SWEEP TIME* can not be used. If a sweep time has been set manually before a nonlinear measurement mode is switched on, *SWEEP TIME AUTO* is selected and a message is displayed.
- For de-coupled channels (*SWEEP SWEEP - COUPLED CHANNELS* off), the nonlinear mode can be configured for each channel individually.

2.4.1.4.1 Compression Point Measurement

SYSTEM MODE - COMPRESS SOI TOI submenu:



The *COMPRESS POINT* softkey switches the compression point measurement on. The parameters are set in the *DEF COMP PNT MEAS* menu. The enhancement label *CMP* indicates that the compression point measurement is active. The compression point measurement can be interpreted as a special formatting of the quantity it is based on. Therefore, *CMP* is displayed in the format field of the information line.

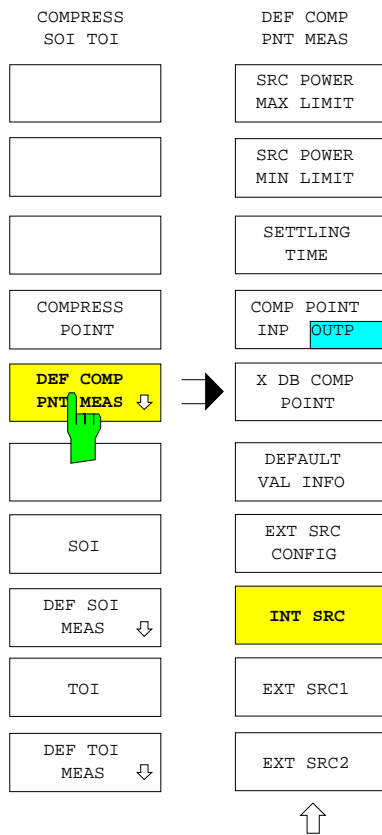
The compression point can be determined for S-parameters and ratios only. If the current measured quantity is a wave quantity, S_{21} is selected automatically.

The algorithm for the compression point performs several steps at each sweep point:

1. The selected S-parameter or ratio is first measured at the lowest allowed generator level (which can be set via *DEF COMP PNT MEAS – SRC POWER MIN LIMIT*). This defines the small-signal value of the measured S-parameter or ratio.
2. Next, the measurement is performed at the largest allowed generator level (*DEF COMP PNT MEAS – SRC POWER MAX LIMIT*). It is checked whether the compression compared to the small-signal value (specified via *DEF COMP PNT MEAS – X DB COMP POINT*) can be reached at all.
3. In the following the compression point is searched by means of iterative interval division. The iteration is stopped when the compression value has been found or after a maximum of 50 cycles without sufficient convergence.
4. After determination of the compression point a last test is made in order to exclude that the receiver of the network analyzer itself caused the compression.

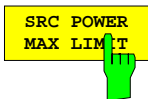
In case that the compression point to be measured is referred to the input of the DUT, the generator level itself is indicated as a measured quantity. If it is referred to the output of the DUT, it is first multiplied by the S-parameter or ratio measured at the compression point.

SYSTEM MODE - COMP SOI TOI - DEF COMP PNT MEAS submenu:



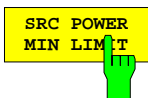
The *DEF COMP PNT MEAS* softkey opens the submenu for setting the parameters which define compression point measurements.

- An upper or lower limit of the source power may be imposed (*SRC POWER MAX/MIN LIMIT*) in order to protect devices which are sensitive to high levels and limit the search range.
- For each single measurement, a delay time (*SETTLING TIME*) may be inserted between the setting of the generator and the beginning of the data acquisition.
- The compression point measured can be referred to either the input or to the output level of the DUT (*COMP POINT INP/OUTP*).
- The compression point (*X DB COMP POINT*) may be entered.
- The measurement procedure for determining the compression point involves plausibility checks which guarantee a correct result. If an error occurs, default values are returned. A list of all default values with possible causes can be displayed (*CHK VALUE SETTINGS*) and the checks can be activated or deactivated individually.
- The measurement can be performed with the internal source (*INT SRC*) as well as with one of the two external sources (*EXT SRC1/2*). External sources may be configured by means of the *EXT SRC CONFIG* table.



The *SRC POWER MAX LIMIT* softkey activates the entry of the maximum generator power to be applied for the compression point measurement. This is useful, e.g., in order to protect sensitive DUTs.

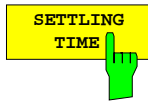
The default value is the maximum available power of the used signal source. If another source is selected, the previous value is maintained if possible.



The *SRC POWER MIN LIMIT* softkey activates the entry of the minimum generator power to be applied for the compression point measurement.

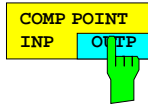
The default value is the minimum available power of the used signal source. If another source is selected, the previous value is maintained if possible.

Note: *In the SRC POWER MAX/MIN LIMIT entry field, the generator powers at the test ports are displayed with the current attenuation of the generator step attenuators taken into account. If power calibration is active for a port, one of the generator power values refers to the reference plane of calibration, the other value is the uncalibrated nominal power of the other port and is marked UNCAL.*

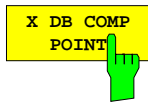


The *SETTLING TIME* softkey activates the entry of a delay time which is inserted into each single measurement between the setting of the generator and the beginning of data acquisition.

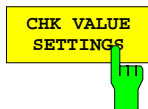
Thus it can be guaranteed that a DUT with a large time constant nevertheless has a sufficient settling time. The total sweep time for a compression point measurement can not be preset manually since the number of single measurements required can not be anticipated.



The *COMP POINT INP OUTP* softkey determines whether the compression point measurement refers to the input (*INP*) or output level (*OUTP*) of the DUT. In the default setting, *OUTP* is active.



The *X DB COMP POINT* softkey activates the entry of the compression value (in dB) to be measured. The default value is 1 dB compression.



The *CHK VALUE SETTINGS* softkey opens the *DEFAULT VALUES AND CHECK SETTINGS OF COMPRESSION POINT MEASUREMENT* table.

The measurement procedure for determining the compression point involves various plausibility checks which guarantee that the measurement is performed correctly. If one of the check fails, e.g. because the compression desired could not be reached, a default value is returned. The *VALUE* column of the *DEFAULT VALUES AND CHECK SETTINGS OF COMPRESSION POINT MEASUREMENT* table lists all possible default values; the cause for each value is described in the *CAUSE* column. Both columns can not be edited.

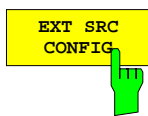
With one exception (internal error of the network analyzer), each check can be switched on or off individually. A checkmark in the editable column *CHK* indicates that the corresponding check is switched on. All checks are switched on by default.

| DEFAULT VALUES AND CHECK SETTINGS OF COMPRESSION POINT MEASUREMENT | | |
|--|--|-----|
| VALUE | CAUSE | CHK |
| 160 dBm | max power range limit reached (power cal only) | ✓ |
| 150 dBm | min power range limit reached (power cal only) | ✓ |
| ... | ... | |
| | | |

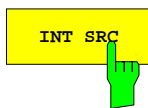
The following default values are defined:

1. **160 dBm: max power range limit reached (power cal only)**
If the generator is power-calibrated, the desired level and therefore the input value of *SRC POWER MAX LIMIT* is no longer restricted to the actual maximum level of the generator, because an additional amplifier might be connected. The default value of 160 dBm indicates that the power defined via *SRC POWER MAX LIMIT* can not be reached at the reference plane of the power calibration even at maximum generator level.
2. **150 dBm: min power range limit reached (power cal only)**
Analogous to 1., if the power defined via *SRC POWER MIN LIMIT* can not be reached even at minimum generator level.
3. **120 dBm: maximum number of iterations reached**
Under normal conditions the compression point is found after less than 20 iteration cycles. If the compression is unstable, e.g. because of noise or other level variations, the iteration algorithm does not converge. In this case, the iteration is stopped after 50 cycles.
4. **110 dBm: receiver compression**
If the DUT exhibits only small compression (or none), or if the output level is very high, the compression point of the receiver might be determined instead of the compression point of the DUT. To prevent this the true signal level at the receiver input (behind the attenuator) is checked after determination of the compression point. If this true signal level exceeds a definite threshold, the default value 110 dBm is returned. In this case it is often sufficient to increase the attenuation value of the receiver step attenuator. Alternatively, an attenuator pad may be connected after the DUT. However, this means that a previously performed receiver power calibration becomes invalid.
5. **100 dBm: compression not reached within source power limits**
This default value is displayed if the maximum generator level specified via *SRC POWER MAX LIMIT* is not high enough to reach the specified compression. A possible remedy is to increase the value of *SRC POWER MAX LIMIT*, to reduce the attenuation of the generator signal, to measure in the external mode (*MODE - EXTERNAL* active), or to use an external generator with higher output power.
6. **-100 dBm: external source error**
When an external generator is used, this default value indicates an error in the IEEE-bus communication with the generator.
7. **<-100 dBm: instrument error**
Default values smaller than -100 dBm indicate an internal error of the network analyzer. This check can not be switched off.

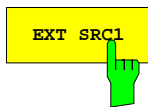
If the softkey *CHK VALUE SETTINGS* is pressed while the compression point measurement is active, the measurement diagram is re-scaled such that the whole range of possible default values is visible. To return to the display of the actually measured values, automatic scaling (*RESPONSE SCALE – AUTOSCALE*) can be used, which does not take the default values into account in this particular case.



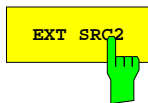
The *EXT SRC CONFIG* softkey activates the table of the same name that configures the external sources, see page 2.120. Note that for a compression point measurement, the *CONNECTION* field setting of the used source is fixed to *GPIB*.



The *INT SRC*, *EXT SRC1* and *EXT SRC2* softkeys select the signal source used for the compression point measurement. The internal source (*INT SRC*) is selected in the default setting.

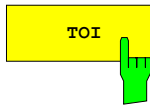
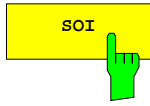


It is recommended to use an external signal source if the expected compression point is higher than 0 dBm input level of the DUT (7 dBm in the external mode). Selection of one of the external sources causes the *EXT SOURCES CONFIG* table to be displayed on the screen (see page 2.120). An external source can be selected only if its *TYPE* is not set to *<NONE>*.



2.4.1.4.2 Measurement of the 2nd and 3rd Order Intercept Point (SOI, TOI)

SYSTEM MODE - COMPRESS SOI TOI submenu:



The SOI and TOI softkeys switch on the measurement of the 2nd and 3rd order intercept, respectively, using the parameters set in the *DEF SOI MEAS* and *DEF TOI MEAS* menus. The enhancement labels SOI or TOI are displayed in this measurement mode. The intercept measurement can be considered as a special formatting. Therefore SOI or TOI is displayed in the format field of the info line.

To determine an intercept point the level of a received wave quantity, i.e. b_1 or b_2 , must be measured. If the current measured quantity is an S-parameter or a ratio, b_2 is automatically selected.

The search algorithm for the intercept performs several steps at each sweep point:

1. For both generator signals, the highest allowed level is first set via *DEF SOI MEAS – SRC POWER MAX LIMIT*. The analyzer checks whether the fundamental wave amplitudes are really equal.
2. Next, the level of the selected intermodulation product is measured. This level must be clearly above the current noise level.
3. The analyzer also checks whether the DUT shows compression. To this end the level of the fundamental wave is reduced by a definite amount in dB, the receiver signal must go down by the same amount. If not, the level reduction is repeated until the compression vanishes or until the minimum generator level is reached.
4. For the last level reduction performed in step 3, i.e. for operation without compression, the intermodulation product must show a quadratic (SOI) or cubic (TOI) behavior. Its level must decrease by the double or triple amount in dB.
5. A last test is made in order to exclude that the receiver of the network analyzer itself caused the measured intermodulation product.

In case that the intercept to be measured is referred to the input of the DUT, it can be calculated from the measured levels of fundamental wave (P_{go}) and the intermodulation product (P_{io}) at the output and the known fundamental wave level P_{gi} at the input (values in dB):

$$SOI = P_{go} - P_{io} + P_{gi}$$

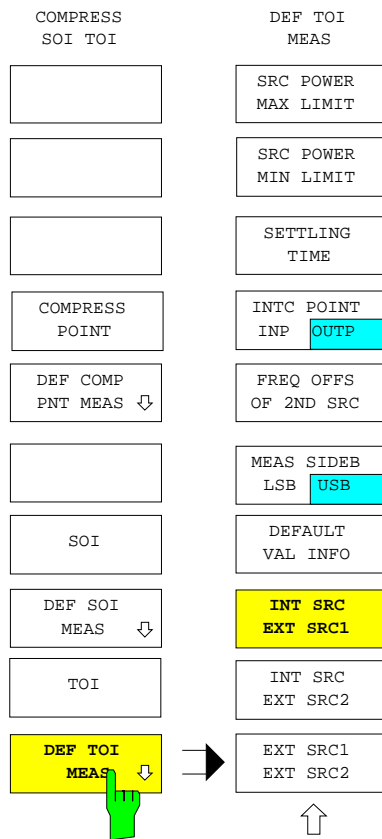
$$TOI = (P_{go} - P_{io}) / 2 + P_{gi}$$

If the intercept is referred to the output, the corresponding equations read:

$$SOI = 2P_{go} - P_{io}$$

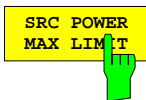
$$TOI = (3P_{go} - P_{io}) / 2$$

SYSTEM MODE - COMP SOI TOI - DEF SOI MEAS submenu:



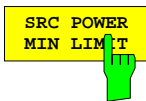
The *DEF SOI MEAS* softkey and *DEF TOI MEAS* open submenus for the setting of the parameters that define the second and third order intercept measurement.

- An upper or lower limit may be imposed to the power of the signal source in order to protect devices which are sensitive to high levels and to limit the search range (*SRC POWER MAX/MIN LIMIT*).
- At each single measurement, a delay time (*SETTLING TIME*) may be inserted between the setting of the generators and the beginning of the acquisition of the measurement value.
- The measured intercept refers either to the input or to the output level (*INTC POINT INP / INTC POINT OUTP*) of the DUT.
- The first signal source is swept over the base frequency range, the second source differs from the first by a user-definable frequency offset (*FREQ OFFS OF 2ND SRC*).
- In the SOI measurement it is possible to specify whether the sum or the difference frequency of both generator signals should be measured (*MEAS FREQ SUM / DIFF*).
- In the TOI measurement it is possible to specify whether the lower (lower side band, *LSB*) or the upper intermodulation product (upper side band, *USB*) should be measured (*MEAS SIDEB LSB/USB*).
- The measurement procedure for determining the intercept point involves plausibility checks which guarantee a correct result. If an error occurs, default values are returned. A list of all default values with possible causes can be displayed (*CHK VALUE SETTINGS*) and the checks can be activated or deactivated individually.
- The fundamental wave signals can be supplied either by the internal source and one of the two external sources (*INT SRC / EXT SRC1/2*) or by the two external sources (*EXT SRC1 / EXT SRC2*).



The *SRC POWER MAX LIMIT* softkey activates the entry of the maximum generator power applied for the measurement of the intercept. This can be used to protect devices which are sensitive to high powers.

The default value is the highest possible power selectable for both sources. If another source is selected, the previous value is maintained if possible.

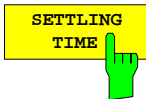


The *SRC POWER MIN LIMIT* softkey activates the entry of the minimum generator level applied for the measurement of the intercept.

The default value is the lowest possible power selectable for both sources. If another source is selected, the previous value is maintained if possible.

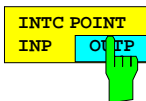
Note:

- In the *SRC POWER MAX / MIN LIMIT* entry field, the generator powers at the test ports are displayed with the current attenuation of the generator step attenuators taken into account. If power calibration is active for a port, one of the generator power values refers to the reference plane of calibration, the other value is the uncalibrated nominal power of the other port and is marked *UNCAL*.
- In the case of some *DUTs* it may be difficult to set the search range with *SRC POWER MAX / MIN LIMIT* so that no default values are needed to generate the trace. So, it is only over a very limited level range that the *DUT* conforms to the model on which definition of the intercept point is based. If, for example, there is no cubic relationship between the amplitudes of the fundamental waves and those of the 3rd-order intermodulation products, measurement of the *TOI* is not meaningful.



The *SETTLING TIME* softkey activates the entry of a delay time which will be inserted into each single measurement between the setting of the signal sources and the beginning of the data acquisition.

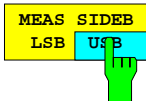
In this way, it can be guaranteed that a *DUT* with a large time constant still has sufficient settling time. For an intercept measurement, the total sweep time can not be entered manually since the number of single measurements required can not be anticipated.



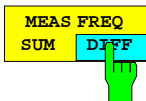
The *INTC POINT INP/OUTP* softkey defines whether the intercept point measurement refers to the input (*INP*) or output level (*OUTP*) of the *DUT*. In the default setting, *OUTP* is active.



The *FREQ OFFS OF 2ND SRC* softkey activates the entry of the frequency offset of the second source relative to the first one. The first source sweeps over the defined frequency range, the second one with a constant relative frequency offset.



The *MEAS SIDEB LSB USB* softkey (in the *DEF TOI MEAS* menu) defines whether the lower (*LSB*) or the upper (*USB*) intermodulation product – referred to the fundamental waves – is to be measured.



The *MEAS FREQ SUM DIFF* softkey (in the *DEF SOI MEAS* menu) defines whether the sum (*SUM*) or the difference (*DIFF*) frequency of the two signal sources is measured.

Note that with *DIFF* set, the intermodulation product is at a constant frequency which is smaller than the frequency of the two sources, but that both fundamental waves must be measured to determine the intercept (see above, *SOI* softkey). Consequently, the network analyzer must cover the current sweep range of both generators.

The measurement procedure for determining the intercept point involves various plausibility checks which guarantee that the measurement is performed correctly. If one of the check fails, e.g. because the intermodulation product is below the noise level, a default value is returned. The *VALUE* column of the *DEFAULT VALUES AND CHECK SETTINGS OF COMPRESSION POINT MEASUREMENT* table lists all possible default values; the cause for each value is described in the *CAUSE* column. Both columns can not be edited.


 CHK VALUE
SETTINGS

The *CHK VALUE SETTINGS* settings opens the *DEFAULT VAL AND CHK SETTINGS OF SECOND / THIRD ORDER INTERCEPT POINT MEASUREMENT* table.

The measurement procedure for determining the intercept point involves various plausibility checks which guarantee that the measurement is performed correctly. If one of the check fails, e.g. because the intermodulation product is below the noise level, a default value is returned. The *VALUE* column of the *DEFAULT VALUES AND CHECK SETTINGS OF COMPRESSION POINT MEASUREMENT* table lists all possible default values; the cause for each value is described in the *CAUSE* column. Both columns can not be edited.

With one exception (internal error of the network analyzer), each check can be switched on or off individually. A checkmark in the editable column *CHK* indicates that the corresponding check is switched on. All checks are switched on by default.

| DEFAULT VAL AND CHK SETTINGS OF THIRD ORDER INTERCEPT POINT MEASUREMENT | | |
|---|--|-----|
| VALUE | CAUSE | CHK |
| 160 dBm | max power range limit reached (power cal only) | ✓ |
| 150 dBm | min power range limit reached (power cal only) | ✓ |
| ... | ... | |

The following default values are defined:

- 160 dBm: max power range limit reached (power cal only)**
 If at least one of the generators is power-calibrated, its desired level and therefore the input value of *SRC POWER MAX LIMIT* is no longer restricted to the actual maximum level of the generator, because an additional amplifier might be connected. The default value of 160 dBm indicates that the power defined via *SRC POWER MAX LIMIT* can not be reached at the reference plane of the power calibration even at maximum generator level.
- 150 dBm: min power range limit reached (power cal only)**
 Analogous to 1., if the power defined via *SRC POWER MIN LIMIT* can not be reached even at minimum generator level.
- 140 dBm: fundamental levels are not equal**
 This default value indicates that the levels of the two fundamental waves measured by the receiver are significantly different. In most cases, the remedy is a power calibration behind the summation point of the generator signals, i.e. at the input of the DUT.

4. **130 dBm: intermodulation product is below noise level at max. source power**

At each sweep point, the current noise limit for the intermodulation product is determined by switching off one of the two generators and measuring several times at the intermodulation frequency. If the intermodulation level generated with maximum generator power (*SRC POWER MAX LIMIT*) is not clearly above this noise limit, either the intermodulation signal is too low, or the noise limit is too high. In order to increase the intermodulation level, the maximum generator power can be increased via *SRC POWER MAX LIMIT*. If this is not possible, generators providing a higher output power can be used. It is also possible that the attenuation in the signal path (e.g. in the signal adder or in the receiver attenuator) is too high. Note that the intermodulation power increases with the square (SOI) or third power (TOI) of the level of the fundamental waves so that even a small enhancement of the generator power might increase the intermodulation level by a considerable amount. To reduce the receiver noise the IF bandwidth can be reduced (*SWEEP AVG – IF BANDWIDTH*).

5. **120 dBm: no square / cubic relationship between intermodulation and fundam. levels**

If the intermodulation level is not reduced by the expected double (SOI) or triple (TOI) amount in dB on lowering the level of the fundamental waves, the default value 120 dBm is returned. This indicates either that the dynamic range for the intermodulation signal is restricted due to the noise (see 4. for possible remedies) or that the nonlinear behavior of the DUT is not compatible with the model applied for the definition of the intercept point. In the latter case the calculation of SOI / TOI doesn't make sense.

6. **110 dBm: receiver intermodulation**

If the DUT shows only small or no intermodulation, or if the output level is very high, the intermodulation product of the receiver might be determined instead of the one of the DUT. The intermodulation level of the receiver can be calculated from its known SOI / TOI and the actual signal level at the receiver input (behind the attenuator). If the measured intermodulation signal level does not clearly exceed the receiver's own intermodulation, the default value 110 dBm is returned. In this case it is often sufficient to increase the attenuation value of the receiver attenuator. Alternatively, an attenuator pad may be connected behind the DUT. However, this means that a previously performed receiver power calibration becomes invalid.

7. **100 dBm: source power limits do not allow for compression-free measurement**

Starting from the maximum allowed generator power (*SRC POWER MAX LIMIT*) the fundamental wave amplitudes are reduced step by step until the compression vanishes. If the minimum generator power (*SRC POWER MIN LIMIT*) is reached before a measurement without compression is possible, the default value 100 dBm is returned. A remedy can be to reduce the minimum generator level *SRC POWER MIN LIMIT*, to increase the attenuation of the generator signal, or to use generators which can provide a lower output power.

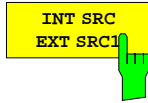
8. **-100 dBm: external source error**

If an external generator is used, this default value indicates an error in the IEEE-bus communication with the generator. This check can not be switched off.

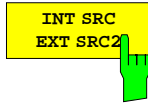
9. **<-100 dBm: instrument error**

Default values smaller than -100 dBm indicate an internal error of the network analyzer.

If the softkey *CHK VALUE SETTINGS* is pressed while the intercept measurement is active, the measurement diagram is re-scaled such that the whole range of possible default values is visible. To return to the display of the actually measured values, automatic scaling (*RESPONSE SCALE – AUTOSCALE*) can be used, which does not take the default values into account in this particular case.



The *INT SRC EXT SRC1*, *INT SRC EXT SRC2* and *EXT SRC1 EXT SRC2* softkeys select the two signal sources used for the intercept measurement. In the default setting, the internal source is combined with the external source 1 (*INT SRC EXT SRC1*).



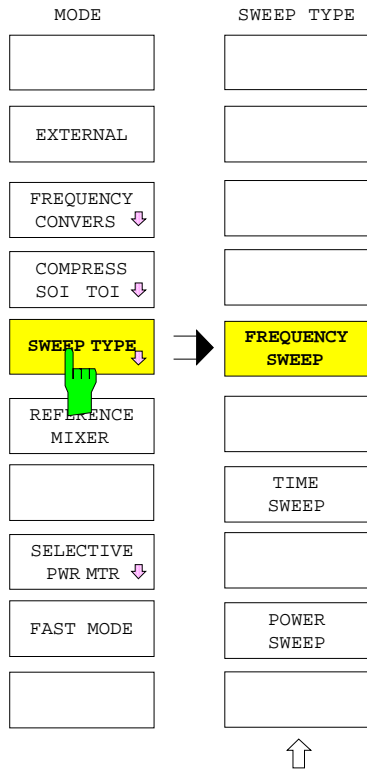
The first source sweeps over the actual range, the frequency of the second source differs from it by a constant, positive offset defined via *FREQ OFFS OF 2ND SRC*.



At the same time, the *EXT SOURCES CONFIG* table (see page 2.120) is displayed. Note that for an intercept measurement, the setting of the *CONNECTION* field of the sources used is fixed to *GPIB*. An external source can be selected only if its *TYPE* is not set to *<NONE>*.

2.4.1.5 Sweep Modes

SYSTEM MODE - SWEEP TYPE submenu:



The *SWEEP TYPE* softkey opens the submenu for selecting the sweep variable. Possible sweep variables are sweeping frequency, time and power of the internal signal source. *FREQUENCY SWEEP* is the default setting.

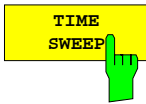
The sweep range is set in the *STIMULUS* key group via the *START*, *STOP*, *CENTER* and *SPAN* keys or via *SWEEP - SWEEP - DEF SWEEP LIST*. The functions which are accessible with the *SWEEP* key only affect the swept variable. The two parameters which are not swept as well as other parameters which remain constant during the sweep are set via the *SOURCE* key.

The settings of the *STIMULUS* and *SWEEP* key groups, the stimuli of the markers as well as formatting, logarithmation and scaling of the test parameter are stored separately for the three sweep modes. For example, a change from *FREQUENCY SWEEP* to *TIME SWEEP* and back again causes the original set of parameters to be active again independent of the settings made in the time sweep.

With decoupled channels (*SWEEP - SWEEP - COUPLED CHANNELS* switched off) the sweep mode can be defined individually for each channel.



The *FREQUENCY SWEEP* softkey activates the frequency sweep mode.



The *TIME SWEEP* softkey activates the time sweep operating mode

The *STIMULUS STOP*, *CENTER* and *SPAN* keys can be used to enter the sweep range. The measurement is started immediately and is repeated cyclically after completion of the time interval. A special field is opened for the entry of times. This entry field is divided in three sections for hours : minutes : seconds and looks like a one-row, three-column table:

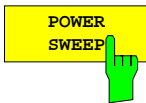
| TIME SWEEP | | |
|------------|-----|-----|
| 0 | HRS | 0 |
| | MIN | 1 |
| | | SEC |

Any values can be entered in each column. The entered values are then automatically converted into hours : minutes : seconds

In the time sweep mode, the CW frequency is displayed in addition at the bottom left in the diagram area of the screen.

Notes:

- If the *SWEEP SWEEP - DEF TRIGGER - TRIGGER SWEEP POINT* softkey is in the *POINT* position, it is switched to *SWEEP* and a message is displayed.
- Compression and intercept point measurements cannot be performed in the *TIME SWEEP* mode. If one of these modes is active when the time sweep is switched on, it is automatically deactivated and a message is displayed.



The *POWER SWEEP* softkey activates the power sweep mode.

The level of the internal source is always swept even in test configurations with external sources.

If a generator level calibration is active, *STIMULUS START* and *STOP* can also be selected outside the normal level range. If the maximum setting range of the internal source is exceeded, however, the enhancement label PC? is displayed.

If option ZVR-B10 („High Power“) is fitted, the sweep power is referred to PORT 1. Depending on the instrument model the level at port 2 is 10 dB to 13 dB lower.

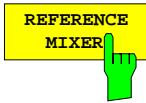
In the power sweep mode, the CW frequency is displayed in addition at the bottom left in the diagram area of the screen.

Note:

Compression and intercept point measurements cannot be performed in the POWER SWEEP mode. If one of these modes is active when the power sweep is switched on, it is automatically deactivated and a message is displayed.

2.4.1.6 Reference Channel Ports (Option ZVR-B6)

SYSTEM MODE menu:



The *REFERENCE MIXER* softkey activates the reference mixer operating mode. This requires the reference channel option (ZVR-B6) to be installed.

In the reference mixer mode, the reference wave parameter *a* which is normally routed internally is applied to the *a1 EXT OUT* socket on the rear panel. This is particularly useful for frequency-converting DUTs, such as mixers.

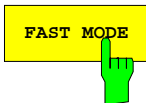
Suppose that the RF input of a known reference mixer, which is provided with the same LO signal as the mixer to be measured, is connected to *a1 EXT OUT*. If the IF signal obtained is applied again to the analyzer via the *a1 EXT IN* socket, a reference signal at the IF is available with the wave parameter *a*. The ratio of test and reference channel can then be used as a measure for the deviation of the DUT from the reference mixer.

a1 EXT OUT and *a1 EXT IN* may be used for fundamental wave measurements, too. For example, a large difference of the electrical length between test and reference channel can be compensated by using a longer connecting cable.

Option ZVR-B6 is not available for ZVK and ZVM. Instead, the signal path of reference wave *a1* can be disconnected between connectors *R1 CHANNEL OUT* and *R1 CHANNEL IN*. In the same way, the reference wave *a2* can be accessed between the connectors *R2 CHANNEL OUT* and *R2 CHANNEL IN*.

2.4.1.7 Fast Measurement (FAST MODE)

SYSTEM MODE menu:



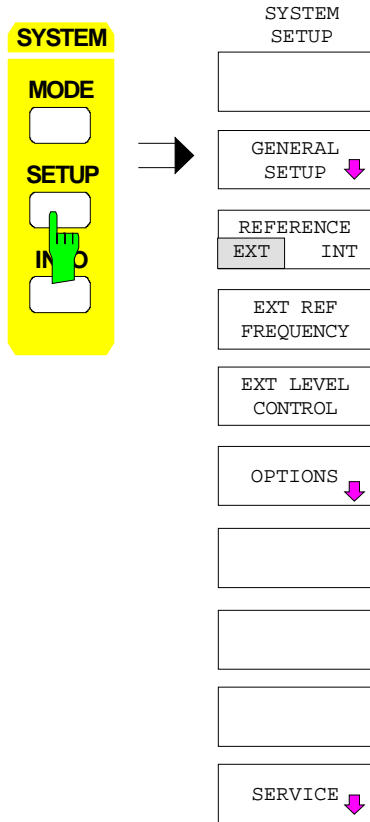
The *FAST MODE* softkey activates the fast measuring mode. In this mode, the enhancement label *FST* is displayed.

The amount of time saved compared to the normal mode increases as the IF bandwidth increases and can exceed 40% for unidirectional measurements at maximum IF bandwidth (*SWEEP AVG - IF BANDWIDTH - FULL*). The measuring accuracy and dynamic range however decrease in *FAST MODE* (see data sheet).

The relative savings in time decrease considerably with receive frequencies below 100 kHz because additional internal wait times occur in both modes and *FAST MODE*. The IF bandwidth is automatically set to *FULL* when *FAST MODE* is switched on. It can however thereafter be changed.

2.4.2 Preliminary Setup and Interface Configuration – SETUP Key

SYSTEM SETUP menu:



The *SETUP* key opens the menu for configuration of the instrument.

This menu contains the basic configurations for the measurement hardware applicable in all instrument modes as well as the interface configuration and features for setting date and time.

With the *SERVICE* softkey located in the menu on the right side of the display screen, special setup functions are provided which, although not necessary in normal use, are useful in instrument service.

2.4.2.1 Programming the Interface Configuration and Time

The *GENERAL SETUP* soft key branches to a sub-menu in which the basic setup of general instrument parameters may be performed. The current settings are displayed in tabular form on the display screen where they may then be edited.

Note: *Interface LPT cannot be configured. If the option FSE-B15, computer function, is installed, LPT can be used for printing in both the measurement instrument mode and the DOS mode. However, it can only be used for one mode at a time.*

SYSTEM SETUP menu:

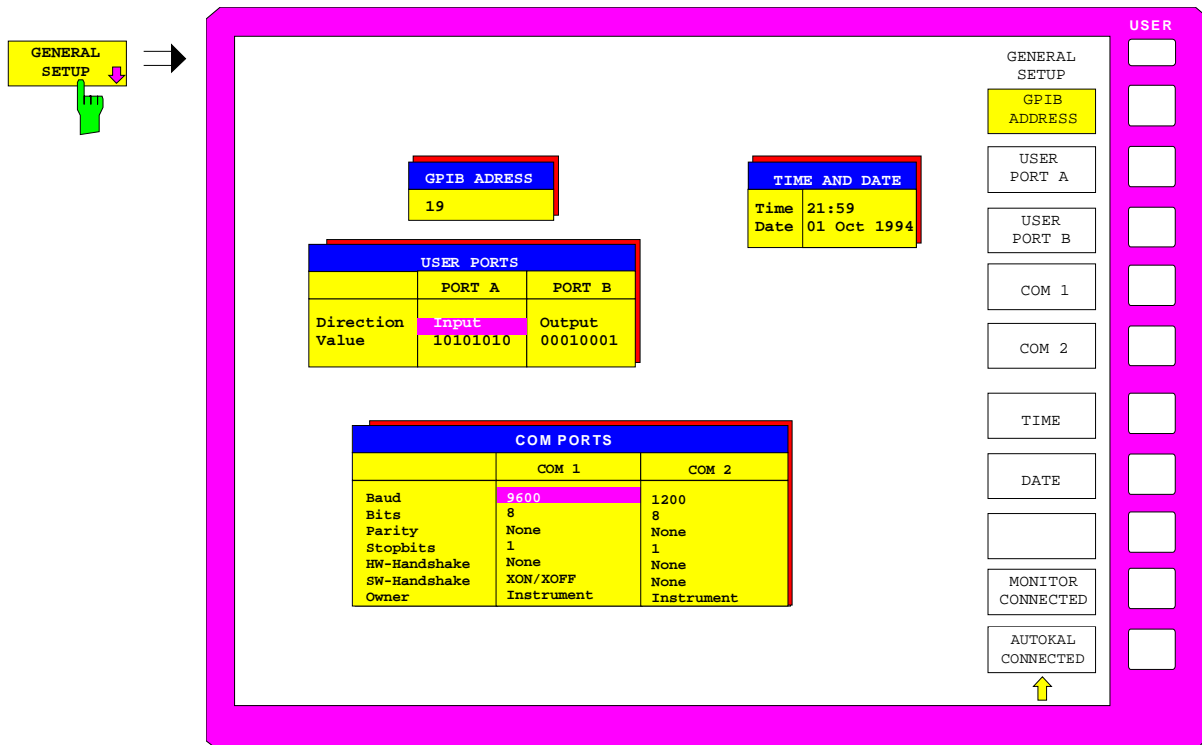
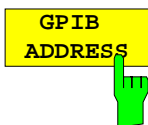


Fig. 2-23 Setting general parameters of the instrument

2.4.2.1.1 IEC Bus Address Selection

SYSTEM SETUP-GENERAL SETUP submenu:

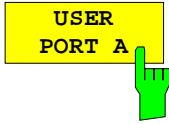


The *GPIB ADDRESS* softkey activates the entry of the IEC Bus address. Permitted addresses are 0 to 30. The default setting is address no. 20.

2.4.2.1.2 User Port Configuration

The instrument provides two parallel interfaces, each of which is 8 bits wide. Over these ports, arbitrary bit patterns can be output or input. The interfaces are designated *USER PORT A* and *USER PORT B*.

SYSTEM SETUP-GENERAL SETUP submenu:



The *USER PORT A* and *USER PORT B* softkeys activate the columns PORT A and PORT B, respectively, in the USERPORTS table for entry of the parameters for both of the parallel interfaces in the instrument. Because the two interfaces are configured in the same manner, how to configure an interface is described in the following using *USER PORT A*.

The following parameters need to be configured in the table:

Direction Direction of data transmission
Value Indication/entry of current value

| USERPORTS | | |
|-----------|----------|--------|
| | PORT A | PORT B |
| Direction | INPUT | OUTPUT |
| Value | 10101010 | |

Direction – Direction of data transmission

The *DIRECTION* parameter determines in which direction the interface transmits data.

INPUT read operation
OUTPUT write operation

| DIRECTION |
|-----------|
| ✓ INPUT |
| OUTPUT |

Value – Indication/Entry of current value

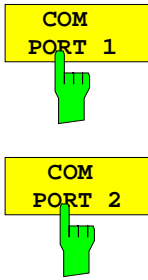
The *VALUE* parameter shows the current value of the data at the port for data input as well as for data output. The displayed data is in binary format with the least significant bit (LSB) on the right.

If the port is configured as an *OUTPUT* then, the displayed value can be edited. Data entry must also be in binary format (i.e., only the digits 0 and 1 are accepted).

| VALUE |
|----------|
| 00010001 |

2.4.2.1.3 Serial Interface Configuration

SYSTEM SETUP-GENERAL SETUP submenu:



The *COM PORT 1* and *COM PORT 2* softkeys activate the columns COM1 and COM2, respectively, for entry of the serial interface parameters. Since the two interfaces are configured in the same manner, how to configure an interface is described in the following using *COM PORT 1*.

The following parameters need to be configured in the table:

| | |
|---------------------|--|
| <i>Baud rate</i> | data transmission rate |
| <i>Bits</i> | number of data bits |
| <i>Parity</i> | bit parity check |
| <i>Stopbits</i> | number of stop bits |
| <i>HW-Handshake</i> | hardware handshake protocol |
| <i>SW-Handshake</i> | software handshake protocol |
| <i>Owner</i> | assignment to the measuring instrument or computer |
| <i>Protocol</i> | transmission protocol |

| COM PORTS | | |
|--------------|------------|------------|
| | COM 1 | COM 2 |
| Baud | 9600 | 1200 |
| Bits | 8 | 8 |
| Parity | None | None |
| Stopbits | 1 | 1 |
| HW-Handshake | None | None |
| SW-Handshake | XON/XOFF | None |
| Owner | Instrument | Instrument |
| Protocol | Remote | Remote |

Fig. 2-24 Setting the parameters for external interfaces

Note: A serial interface (COM1 or COM2) cannot be used for another purpose if a mouse is connected to it.

Baud – Data transmission rate

Allowed are the indicated values between 110 and 19200 baud. The default setting is 9600 baud.

| BAUD RATE |
|-----------|
| 19200 |
| ✓ 9600 |
| 4800 |
| 1200 |
| 600 |
| 300 |
| 150 |
| 110 |

Bits – Number of data bits per word

For the transmission of text without German umlauts (Ä, ä, Ü, ü, Ö, ö) and special characters, 7 bits are adequate. For binary data as well as text with special characters or umlauts, 8 bits must be selected (default setting).

| BITS |
|------|
| ✓ 7 |
| 8 |

Parity – Bit parity check

NONE no parity check (default setting)

EVEN even parity check

ODD odd parity check

| PARITY |
|---------------|
| <i>NONE</i> |
| ✓ <i>EVEN</i> |
| <i>ODD</i> |

Stopbits – Number of stop bits

Available are 0, 1 and 2. The default setting is 1 stop bit.

| STOPBITS |
|----------|
| 0 |
| ✓ 1 |
| 2 |

HW-Handshake – Hardware handshake protocol

The integrity of data transmission can be improved through the use of a hardware handshake protocol which effectively prevents uncontrolled transmission of data and the resulting possible loss of data bytes. In the hardware handshaking procedure, additional interface lines are used to transmit acknowledge signals with which the data transmission can be controlled and, if necessary, stopped until the receiver is ready to receive data again.

A prerequisite for handshaking is, however, that the interface lines (DTR and RTS) are provided between sender and receiver. For a simple, 3-wire connection, this is not the case and hardware handshake cannot be realized here.

Default setting is *NONE*.

| HW-HANDSHAKE |
|------------------|
| <i>None</i> |
| ✓ <i>DTR/RTS</i> |

SW-Handshake – Software handshake protocol

Besides the hardware handshake procedure using interface lines, it is also possible to achieve the same effect by using a software handshake protocol. Here, control bytes are transmitted in addition to the normal data bytes. These control bytes can be used, as necessary, to stop data transmission until the receiver is ready to receive data again.

In contrast to hardware handshaking, software handshaking can be realized even for a simple, 3-wire connection.

One limitation is, however, present in software handshaking. Software handshaking cannot be used for the transmission of binary data since, the control characters XON and XOFF require bit combinations that are also used for binary data transmission.

Default setting is *NONE*.



Owner – Assignment of the interface

When the processor option FSE-B15 is installed, the serial interface can be assigned alternatively to the instrument measurement section, the DOS section or to both sections of the instrument.

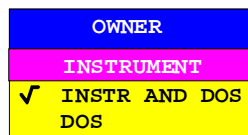
If the interface is assigned to only one section of the instrument, it is not available to the other section.

INSTRUMENT The interface is assigned to the instrument measurement section. Outputs to the interface from DOS are not possible and, so to say, land nowhere.

DOS The interface is assigned to the DOS section. It cannot be used by the instrument measurement section. This means that hardcopy or remote control of the instrument via the interface is not possible. An attempt to start a print job via the interface results in an error message. The *PROTOCOL* parameter has no meaning in this mode.

INSTR AND DOS The interface is allocated to both instrument sections. It may be used alternately by each section. This means that a hardcopy job from the measurement section and a data transfer from DOS are not possible at the same time. This would lead to a mixing of the data streams.

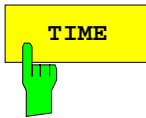
The set interface parameters, with the exception of *PROTOCOL*, are valid for both instrument sections. The *PROTOCOL* parameter is only of interest for the measurement section.



Note: *DOS programs cannot independently recognize changed interface parameter settings.*

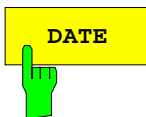
2.4.2.1.4 Setting Date and Time

SYSTEM SETUP-GENERAL SETUP submenu:



The *TIME* softkey activates the entry of time for the internal real-time clock . In the corresponding dialog box, the time is partitioned into two input fields so that hours and minutes can be entered independently.

| TIME AND DATE | |
|---------------|-------------|
| Time | 21:59 |
| Date | 01 Oct 1994 |



The *DATE* softkey activates the entry of the date of the internal real-time clock. In the corresponding dialog box, the date is partitioned into 3 input fields so that day, month and year can be input separately.

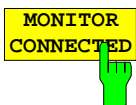
| DATE | | | |
|------|----|-----|------|
| DATE | 10 | MAY | 1995 |

For the selection of the month, pressing a units key opens a list of abbreviations wherein the desired month can be selected.

| MONTH | |
|-------|-----|
| | JAN |
| | FEB |
| | MAR |
| | APR |
| | MAY |
| | JUN |
| ✓ | JUL |
| | AUG |
| | SEP |
| | OCT |
| | NOV |
| | DEC |

2.4.2.1.5 Connecting the External Monitor

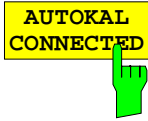
Submenu SYSTEM SETUP-GENERAL SETUP:



Softkey *MONITOR CONNECTED* informs the unit that an external monitor is available at PC MONITOR connector. The external monitor displays the Windows NT screen.

2.4.2.1.6 Indication of the Automatic System Error Calibration

SYSTEM SETUP-GENERAL SETUP submenu:

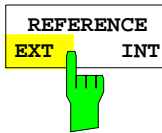


The switched-on *AUTOKAL CONNECTED* softkey indicates to the network analyzer whether the automatic calibration standard for option ZVR-B1, AutoKal, is connected. Option ZVR-B1 and thus *AUTOKAL CONNECTED* softkey is available for all models except ZVRL, ZVK and ZVM.

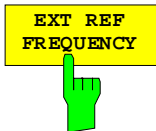
When *AUTOKAL CONNECTED* is switched on, the softkeys *AUTOKAL* and *AUTOKAL FUNDAM'TAL* are displayed in the *CAL* menu. As the automatic calibration standard is connected via *USER PORT B*, editing of the corresponding column in table *USER PORTS* is no longer possible. On switching on *AUTOKAL CONNECTED*, the automatic calibration standard is initialized via *USER PORT B*.

2.4.2.2 External Reference Oscillator

SYSTEM SETUP menu:



The *REFERENCE EXT/INT* softkey switches between internal and external source of the reference frequency. The signal of an external reference source is fed in via the rear panel connector *REF IN*. The voltage must be between 0.1 V and 3 V (RMS). The frequency can be set via the *EXT REF FREQUENCY* softkey. If no appropriate signal is applied to *REF IN* while the external reference frequency is activated, the error message *CAUTION: REFERENCE UNLOCKED* is displayed on the screen.



The *EXT REF FREQUENCY* softkey activates the entry of the frequency of the external source. This frequency can be set between 1 MHz and 15 MHz in multiples of 1 MHz:



The *EXT LEVEL CONTROL* softkey switches the level control by an external signal applied to the rear panel connector *LEVEL* on or off.

In the external level control mode, the input voltage of the external signal (permissible range 0 V to 10 V) determines the power of the internal source (signal switched off to maximum power). The relation between both quantities is non-linear. External level control is an alternative to manual entry of the internal signal level via the *SWEEP – SOURCE – POWER* softkey.

In the frequency range below 150 MHz, a suitable attenuation value (see *SWEEP – SOURCE* menu) may be set with external level control, too.

2.4.2.3 Enabling Firmware Options

SYSTEM SETUP menu:

The *OPTIONS* softkey opens a submenu for entering keywords for new firmware options (Application Firmware Modules). Options which are already available are indicated in a table that is opened when the menu is called.

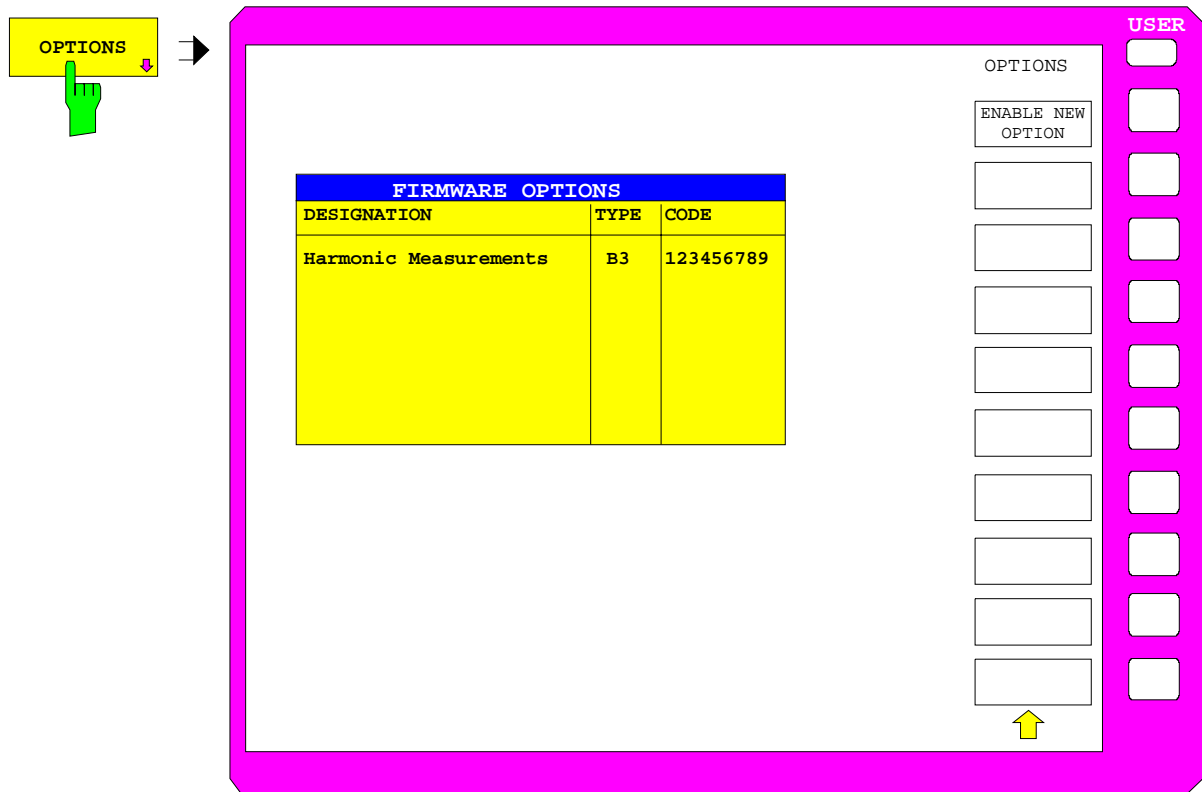
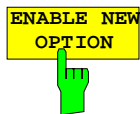


Fig. 2-25 Enabling firmware options



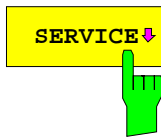
The *ENABLE NEW OPTION* soft key activates the entry of a keyword for a firmware option.

One or several keywords may be specified in the entry field. When a valid keyword is entered, the message *OPTION KEY OK* appears in the info line and the option is written into the *FIRMWARE OPTIONS* table.

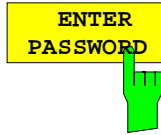
The *FIRMWARE OPTIONS* table can also be displayed using the *FIRMWARE OPTIONS* softkey in the *INFO* menu.

If a keyword is invalid the message *OPTION KEY INVALID* is displayed in the info line.

2.4.2.4 Service Functions

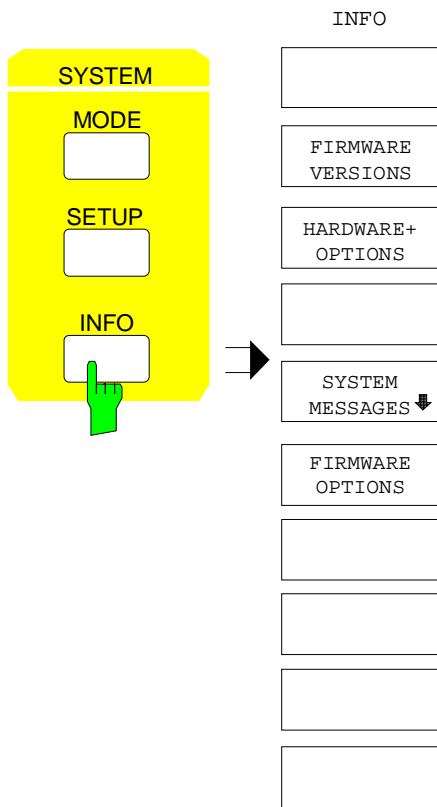


The *SERVICE* submenu contains a number of service functions that are described in detail in the service manual. If not applied properly, these functions may cause malfunctions in the instrument. Therefore they are protected by a keyword which can be entered via the *ENTER PASSWORD* softkey.



The *ENTER PASSWORD* softkey activates the entry of a password which gives access to the service functions.

2.4.3 Instrument Status and Measurement Parameters – INFO Key



The *INFO* key is used to request general information concerning the instrument. These include:

- the firmware version,
- the names of installed hardware options,
- modification level of the individual modules,
- a list of generated system messages.
- a list of installed firmware options.

2.4.3.1 Firmware Versions

SYSTEM INFO menu:



The *FIRMWARE VERSIONS* softkey opens three tables, which provide the following information:

- Table *MODEL TYPE* displays the exact instrument model and type.

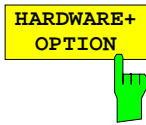
| MODEL | TYPE |
|-------|------|
| ZVR | 12B |

- In the *FIRMWARE VERSIONS* table, the version of each software component installed in the instrument is listed. The versions of programmable logic devices are also included if the firmware version number of the device can be determined.

| FIRMWARE VERSIONS | |
|-------------------|------------|
| BIOS | 2.1 |
| ANALYZER | 1.61 |
| SERIAL NUMBER | 825047/011 |

2.4.3.2 Hardware Configuration and Options

SYSTEM INFO menu:



The *HARDWARE+OPTIONS* softkey opens two tables where the modules (*INSTALLED COMPONENTS*) and options (*INSTALLED OPTIONS*) installed in the instrument are listed.

- Similar to the function *FIRMWARE VERSIONS*, the table *MODEL TYPE* lists the instrument model and type:

| MODEL | TYPE |
|-------|------|
| ZVR | 12B |

- The *INSTALLED COMPONENTS* table consists of four columns:
 COMPONENT name of module
 MODEL INDEX model number of the module
 MODIF INDEX modification index of the module
 HW CODE code for optional fitting of module components

The table lists only the modules which are actually present in the instrument, i.e., the modules which were identified by the module recognition software.

| INSTALLED COMPONENTS | Model Index | Modif Index | HW Code |
|--------------------------|-------------|-------------|---------|
| Main CPU | | | |
| Graphics Board | | | |
| I/O-Board | | | |
| Measurement Control Unit | | | |
| Converter A | | | |
| Converter B | | | |
| Synthesizer | | | |
| Local | | | |
| Source | | | |
| Output Stage | | | |
| Frontend | | | |
| Testset | | | |



The *FIRMWARE OPTIONS* softkey opens a table listing the installed firmware options.

The *FIRMWARE OPTIONS* table contains three columns:

| | |
|-------------|-----------------------------|
| DESIGNATION | name of the firmware option |
| TYPE | short type designation |
| CODE | enabling code |

| FIRMWARE OPTIONS | | |
|--------------------|------|--------|
| DESIGNATION | TYPE | CODE |
| Mixer Measurements | B4 | 123456 |

New firmware options can be enabled via the *ENABLE NEW OPTIONS* softkey (*SYSTEM SETUP* menu, see section 2.4.2.3).

2.4.3.3 System Messages

The *SYSTEM MESSAGES* softkey opens a submenu including a table in which the generated system messages are displayed. The most recent messages are at the top of the list. The following information is presented:

| | |
|-----------|--|
| NO | Device specific three digit error code |
| MESSAGE | Brief description of the reason for the message |
| COMPONENT | Hardware messages: name of the affected module Software messages: if needed, the name of the affected software components |
| DATE/TIME | Date and time of occurrence of the message |

The system messages are displayed in various colors:

| | |
|---------------------|--|
| Red error message | The message has occurred since the last call to the <i>SYSTEM MESSAGES</i> menu, |
| Black error message | The message was already present at the last call. |

SYSTEM INFO menu:

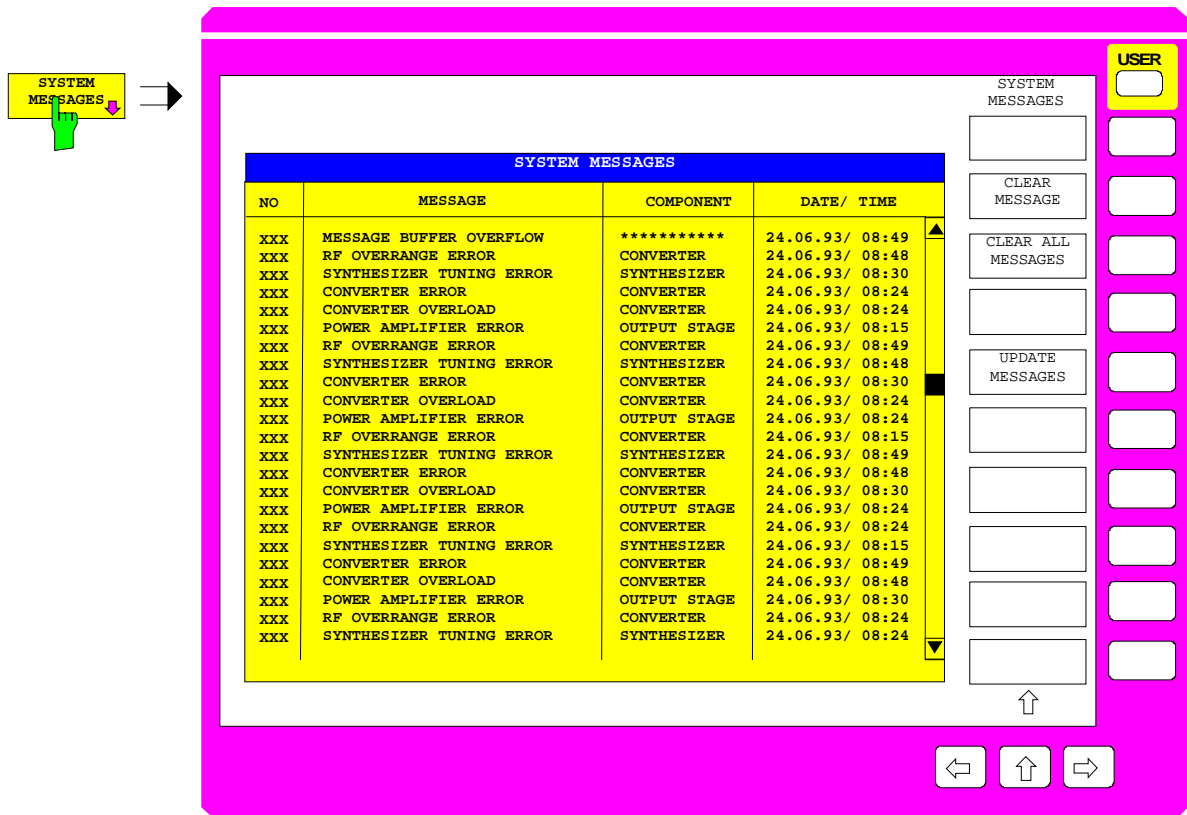
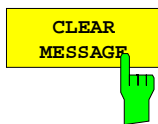


Fig. 2-26 System messages

SYSTEM INFO-SYSTEM MESSAGES submenu:

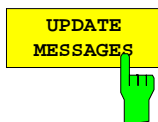


The *CLEAR MESSAGE* softkey deletes the message just selected.

All subsequent messages are shifted automatically one line upwards so that no empty lines exist. When the last message has been deleted, the selection bar also disappears.



The *CLEAR ALL MESSAGES* softkey deletes all messages.



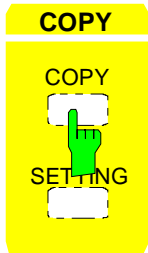
The *UPDATE MESSAGES* softkey causes all newly arrived messages to be entered at the top of the table. At this time, all messages previously indicated as "new" are displayed as "old" messages.

2.5 Measurement Documentation – COPY Key Group

2.5.1 Printing Data – COPY Key

The instrument uses the printer function of Windows NT to output hardcopies. Any printer supported by Windows NT can be used. In addition, the instrument permits data output in the usual data formats WMF, EWMF and BMP which enable hardcopies to be directly inserted into other documents. Network printers can be used if the instrument is connected to a network.

To be able to reproduce all the characters of a WMF printout that has been inserted into a MS Windows program (e.g. Word), the MS Linedraw font must be installed on the PC. The file linedraw.ttf is to be found in the instrument-internal directory C:\WINNT\FONTS.



The *COPY* key initiates the printing of measurement/ instrument status data. The instrument can distinguish between two different output devices, each of which may be individually configured, e.g., a laser printer and a ink jet printer. All documents are printed on the output device which is currently active.

Pressing the *COPY COPY* key initiates the print job. The printer parameters defined under Windows NT and in the *COPY SETTING* menu are used for setting up the printer configuration. After pressing the *COPY* key, all of the display items to be printed are written to the printer buffer of Windows NT. Since the printer runs in the background, the instrument may be operated immediately after pressing the *COPY* key.

With *COPY SCREEN* selected in submenu *COPY SETTING-SEL ITEMS TO COPY*, all the diagrams with traces and status displays are printed as they occur on the screen. Softkeys, open tables and data entry fields are not printed out. Function *COPY TRACE* allows to print out individual traces. With *COPY TABLE* tables can be printed out.

If output device *CLIPBOARD* is active in menu *COPY SETTING*, submenu *HARDCOPY DEVICE*, the clipboard can be used to directly transfer hardcopies to Windows applications. The copy is written in the clipboard by pressing *COPY*. The user can then change to another Word document and insert the clipboard content into the document via the menu *EDIT - PASTE* by using the key combination *CTRL+V*.

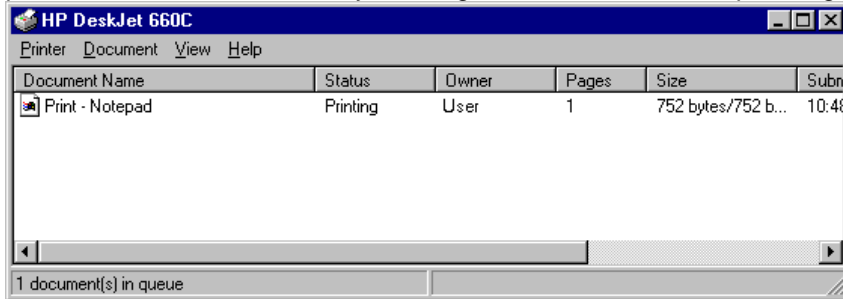
If the *FILE* option in the *HARDCOPY DEVICE* submenu of the *COPY SETTING* menu is selected then, upon pressing *COPY*, the file name to which the output data are to be written is requested. For this an entry field is opened for entering the file name. If no external keyboard is connected, the help line editor is activated.

If the *COPY* key is pressed again during an active print job, a second output can be released which can also be joined to the printer queue. Any number of print jobs can be released consecutively.

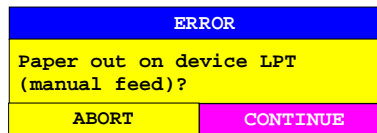
Current print jobs can be aborted only by canceling the entries in the Windows NT printer queue. After starting the print a printer symbol is displayed in the task bar near the time indication.



A double-click on this symbol opens a window containing the entries of the printer queue. The relevant print order can be cancelled by marking it with the mouse and pressing the DEL key.



While a print job is in progress, problems may occur in the output device. If, while printing, the output device issues a PAPER OUT message, i.e., no more paper is available, the user will be prompted by the following message



to load paper into the output device. The print job will then be either continued (CONTINUE selected) or aborted (ABORT selected).

Switchover between b/w and colored printouts is possible with softkey *COLOR ON/OFF* provided that the printer connected is able to output such prints. The colors of the printout correspond exactly to those of the screen, ie a red trace will be output in red.

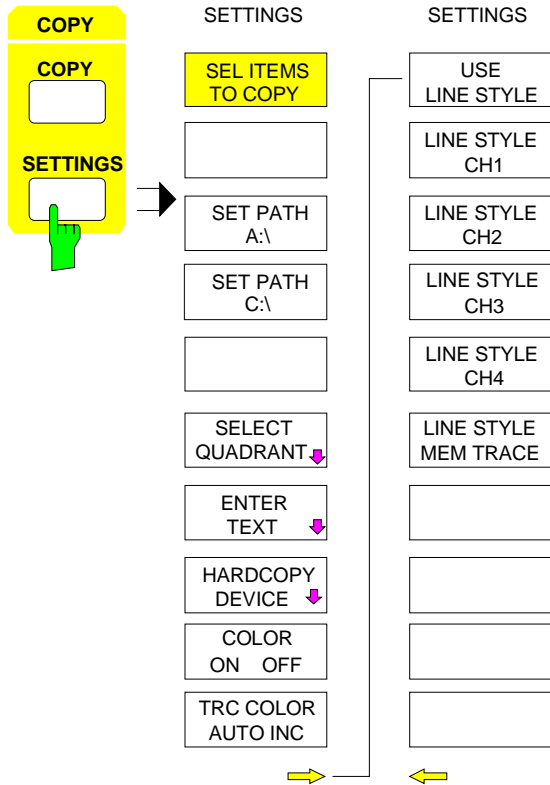
To change the colors of the objects on the printout, the screen colors have to be changed correspondingly in menu *RESPONSE DISPLAY*, submenu *CONFIG DISPLAY*. One exception is the color of the background and the color of the diagrams. The output background is always white irrespective of the screen color and the diagrams are always black.

If several traces are to be output one after the other on the same sheet different colors can be chosen for each trace with the aid of softkey *TRC COLOR AUTO INC* (Trace Color Auto Increment).

On most b/w printers, a better printout of the color screen is obtained on hardcopies if the color information is converted into gray shades. For this, the color output in menu *COPY SETTINGS* is to be activated (COLOR ON).

2.5.2 Printing Configuration – *SETTING* Key

COPY SETTING menu:



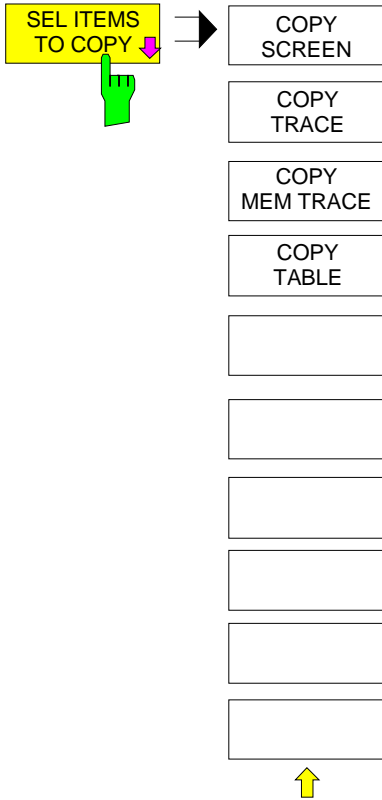
SETTINGS opens a configuration menu for the output of graphics, parameter lists and test reports to a printer, plotter or in the form of files.

To generate a hardcopy, the following procedure is recommended:

1. Configure the desired output device and select the output interface by means of softkey *HARDCOPY DEVICE*.
2. Select displayed elements to be printed from *SEL ITEMS TO COPY* submenu.
3. Select color or monochrome hardcopy by means of softkeys *COLOR ON/OFF* and *TRC COLOR AUTO INC*.
4. Comments on graphics or a title for the hardcopy can be added by means of softkey *ENTER TEXT*.
5. Select display mode (QUADRANT, FULL PAGE) by means of softkey *SELECT QUADRANT*.

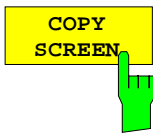
2.5.2.1 Selection of Displayed Elements

COPY SETTING-SEL ITEMS TO COPY submenu:



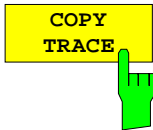
The *SEL ITEMS TO COPY* submenu comprises the four softkeys *COPY SCREEN*, *COPY TRACE*, *COPY MEM TRACE* and *COPY TABLE*. With these softkeys you can select the displayed elements to be printed.

Only one of the softkeys can be active at a time. The softkeys are only for selecting the item to be printed, not for starting printing. Printing is started with the key *COPY COPY*.

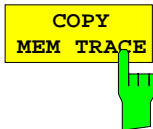


The softkey *COPY SCREEN* is used to print out measurement results.

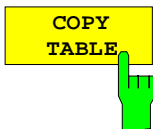
All diagrams, traces, markers, marker lists, display lines, limit lines etc. are printed out, provided they appear on the display screen. Softkeys, tables and open data entry windows are not printed out. In addition, any entered comments, title, date and time are printed out in the lower margin of the print-out. The logo appears in the upper left corner of the print-out.



Using the *COPY TRACE* softkey, all traces visible on the display screen are printed out without auxiliary information. Specifically, no markers or display lines are printed.



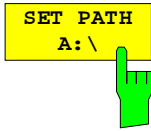
Using the *COPY MEM TRACE* softkey, the memory trace visible on the display screen is printed out, provided it exists, without auxiliary information. Similar to the *COPY TRACE* softkey, no markers or display lines are printed.



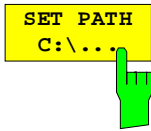
Using the *COPY TABLE* softkey, all tables visible on the display screen are printed out.

2.5.2.2 Selection of Data Medium

If you have selected a file under *HARDCOPY DEVICE*, use the softkeys *SET PATH A:* and *SET PATH C:\...* to select the data medium on which the file is to be stored. When one of the softkeys is activated, the entry field PRINT TO FILE opens. The field contains a preconfigured file name which can be edited.



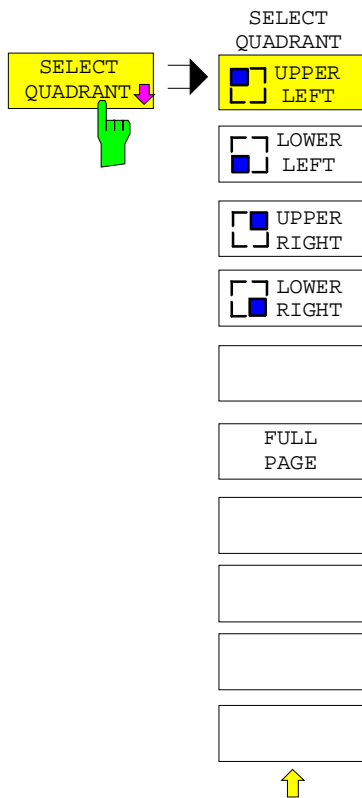
The *SET PATH A:* softkey opens the PRINT TO FILE entry field with the preconfigured file name A:\SPOOL.XYZ. XYZ stands for the file type selected under *HARDCOPY DEVICE*.



The *SET PATH C:\...* softkey opens the PRINT TO FILE entry field with the preconfigured file name C:\USER\DATA\SPOOL.XYZ. XYZ stands for the file type selected under *HARDCOPY DEVICE*.

2.5.2.3 Selection of Hardcopy Format

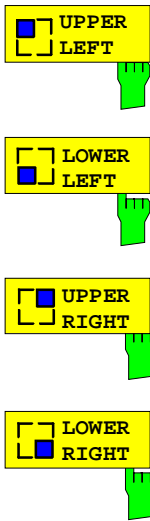
COPY SETTING-SELECT QUADRANT submenu:



With the functions of the *SELECT QUADRANT* menu, the location of the displayed screen graphics on the printed page can be selected.



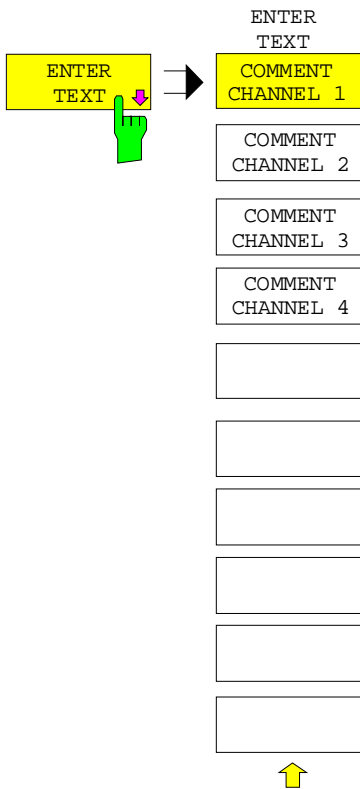
The *FULL PAGE* softkey switches quadrant printing off, i.e., printing now takes place at full size. The information as to which quadrant was last selected is also lost. *FULL PAGE* is the default setting.



The *UPPER LEFT*, *LOWER LEFT* as well as *UPPER RIGHT*, *LOWER RIGHT* softkeys select the page quadrants where the printed data will be positioned. In this case, the actual size of the data printed on the page is reduced to 25% of normal size. This reduction is independent of how the graphics are distributed on the display screen. Thus, in the modes *DUAL SPLIT* and *QUAD SPLIT*, both measurement diagrams (*DUAL SPLIT*) or all four diagrams (*QUAD SPLIT*) shown on the display are placed in the chosen quadrant. Thus, up to a maximum of 16 measurement diagrams can be printed on one page (4 print commands for a *QUAD SPLIT* display, each to a different quadrant).

2.5.2.4 Entry of Comment Text

COPY SETTING-ENTER TEXT submenu:



With the functions of the *ENTER TEXT* menu, commentary for individual diagrams can be entered. The comment text appears in the print-out, but does not appear on the display screen.

If you don't want the comment text to appear in the print-out, you must delete it.

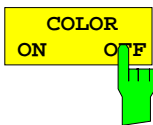
All entered comment texts are deleted when the instrument is reset via the *PRESET* key.



The *COMMENT CHANNEL 1, 2, 3* and *4* softkeys open an entry field in which a comment of two lines (60 characters per line) can be entered pertinent to the applicable channel. If the user enters more than 60 characters, the excess characters appear on the second line on the print-out. Note: at any point, a manual line-feed can be forced by entering the @ character. The commentary is printed below the corresponding diagram.

2.5.2.5 Color Settings

COPY SETTING menu:

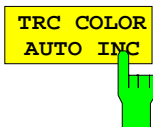


The *COLOR ON/OFF* softkey selects either a color or a black and white print-out (provided that the connected printer is capable of printing in color). The colors of the print-out correspond exactly with the display colors, i.e. a red trace will be printed in red by the printer.

In order to change the colors of the objects on the print-outs, the display colors must be changed in the *DISPLAY - CONFIG DISPLAY* submenu. Exceptions to this rule are the background color and the diagram color. The background is, independent of the display screen color, always white on the print-out and the diagrams are always black.

The softkey automatically switches to *ON* if the printer driver or the hardcopy device is changed (both of these functions appear in the *COPY SETTING* submenu).

An exception to this rule is the printer driver HP PCL4, which only supports black and white print-outs. In this case, the softkey cannot be operated.



The *TRC COLOR AUTO INC* softkey automatically increments the trace colors from one print-out to the next. On the second print-out, trace 1 is assigned the color from trace 2, trace 2 the color from trace 3, etc. The trace color assignments thus correspond with the initial state again after four print-outs. The trace colors are reset to their initial state when the softkey is switched off.

The *TRC COLOR AUTO INC* softkey is switched off when the printer driver or the hardcopy device is changed (both of these functions appear in the *COPY SETTING* submenu) or when a black and white print-out has been selected (*COLOR ON/OFF* softkey is set to *OFF*).

2.5.2.6 Selection and Configuration of the Output Device

The instrument permits two different output devices to be configured. One of the devices is defined as the active device and can be used for hardcopies.

The installation and configuration of these output devices is mainly done under Windows NT and is valid for all Windows applications (see Chapter 1, section "Connecting an Output Device"). The active device and the settings which concern only the output of hardcopies are selected in menu *COPY DEVICE*.

The *HARDCOPY DEVICE* softkey switches to the sub-menu which is used for the selection/configuration of the two output devices.

When the sub-menu is called, the corresponding table is simultaneously displayed. The *SETTINGS DEVICE 1* softkey is active and the selection bar is located at the *DEVICE 1* line.

COPY SETTING-HARDCOPY DEVICE submenu:

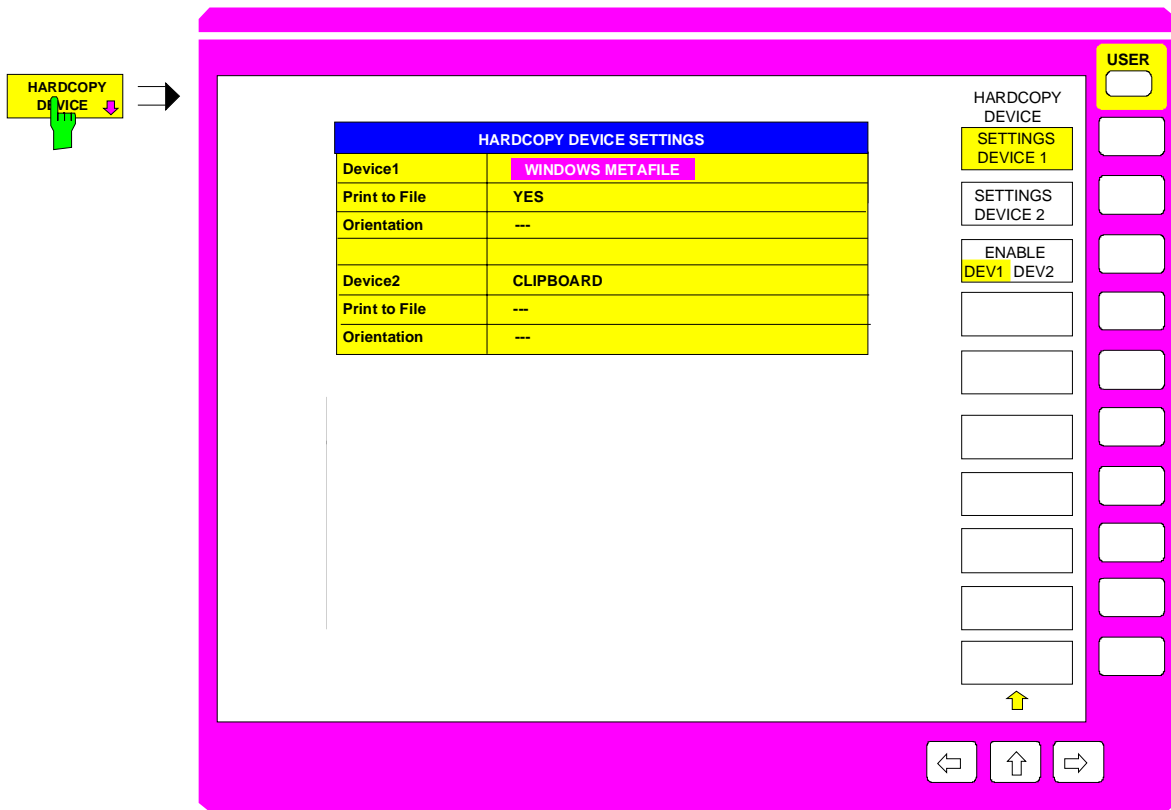
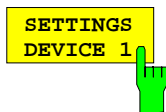
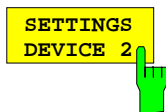


Fig. 2-27 Configuration of the output device



After calling the menu, the *SETTINGS DEVICE 1* soft key is active and permits the selection and configuration of the output device *DEVICE 1*. The *SETTINGS DEVICE 2* soft key is used to configure *DEVICE 2*.



The actual selection of the active output device takes place with the *ENABLE DEV1 DEV2* soft key in the *HARDCOPY DEVICE* sub-menu.

Device

The selection of the output device/language for DEVICE 1 and DEVICE 2 is made in this line.

| HARDCOPY DEVICE SETTINGS | |
|--------------------------|------------------|
| Device1 | WINDOWS METAFILE |
| Print to File | YES |
| Orientation | --- |
| | |
| Device2 | CLIPBOARD |
| Print to File | --- |
| Orientation | --- |

| DEVICE |
|-------------------|
| ✓ CLIPBOARD |
| WINDOWS METAFILE |
| ENHANCED METAFILE |
| BITMAP FILE |
| HP DeskJet 660C |

Three file formats and the Windows NT clipboard are always available, even if a printer has not yet been installed under Windows NT. All installed printers are listed below in alphabetic order.

The printer installation is described in Chapter 1, section 1.8.

CLIPBOARD When "Clipboard" is selected the hardcopies are copied to the Windows NT clipboard. This permits to obtain a printout of high quality which can be directly inserted into other Windows applications (menu EDIT | PASTE or key combination CTRL+V). The lines 'Print to File', 'Orientation' and 'GPIB Address' are deactivated.

WINDOWS METAFILE and ENHANCED METAFILE

WMF and EWMF are vector graphics formats which can be imported by most graphics and editing programs. EMF is recommended for recent Windows32 applications.

BITMAP FILE BMP is a bitmap format which can also be imported by most programs.

When WMF, EWMF and BMP are selected, the line "Print to File" is automatically set to ON and line "Orientation" deactivated.

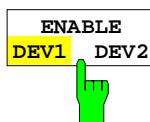
Print to File

With "Print to File" ON, the printout is directed to a file. In this case the user is prompted to enter a file name on calling up *COPY*.

Note: This setting is coupled to the corresponding setting under Windows NT.

Orientation

In this line, the print format of the output page is set to either vertical (= PORTRAIT) or horizontal (= LANDSCAPE).



The *ENABLE DEV1 / DEV2* soft key determines the active output device. The default output device is DEVICE 1, i.e., all output takes place on DEVICE 1.

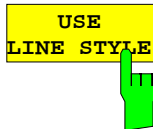
2.5.2.7 Selection of Line Style

For output to a plotter, different test traces can be assigned different *line styles*. The test traces of a chart can thus be represented by various types of dotted and dash-dotted lines.

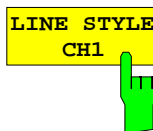
The line styles actually printed in the hardcopy depend on the plotter used. For this reason, no generally applicable assignment of line style to the sample shown can be made here.

All functions needed for line configuration will be found can be selected by means of the line-style softkeys. These softkeys are available only if a plotter is selected as an output device.

COPY SETTING line-style softkeys:

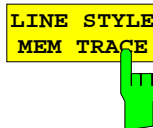
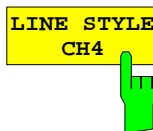
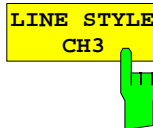
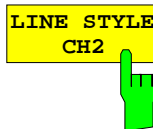


The softkey *USE LINE STYLE* switches the line configuration function on or off. The other line-style softkeys are available only if the softkey *USE LINE STYLE* is active.



Each of the softkeys *LINE STYLE CH1* to *LINE STYLE CH4* opens an input field for defining the line style for the test trace of a given channel.

The line style is defined with a number between 0 and 7.



The softkey *LINE STYLE MEM TRACE* opens an input field for defining the line style for all stored test traces (memory traces).

It is not possible to define different line styles for memory traces of different channels.

2.6 Saving and Recalling Data Sets – *MEMORY* Key Group

The keys in the *MEMORY* group call the following functions:

- Functions for management of storage media (*CONFIG*). Included are among others functions for listing files, formatting storage media, copying, and deleting/rename files.
- Storage/loading functions for storing (*SAVE*) instrument settings such as instrument configurations (operating modes, measurement/display settings, etc.), calibration parameters and measurement results from working memory to permanent storage media, or to load (*RECALL*) stored data into working memory.

The network analyzer is capable of internally storing complete instrument settings with instrument configurations and measurement data in the form of data sets. The respective data are stored on the internal hard disk or, if selected, on a floppy. The hard-disk and floppy-disk drives are assigned logical names as usual in PC applications:

| | |
|-------------|----|
| floppy disk | A: |
| hard disk | C: |

In addition to the saving and recalling of complete instrument settings, it is also possible to save/recall subsets of settings. Configuration data and measurement values are stored in separate files. These files have the same name as the data set but however have a different extension. A data set thus consists of several files which have the same name but different extensions (see Table 2-2).

When saving or loading a data set, the subsets which are to be saved or loaded can be selected in the corresponding menus. This makes it easy to reconstruct specific instrument settings.

When saving and loading data via the *SAVE* and *RECALL* menus, partial data sets are selected in a table in the sub-menu *SEL ITEMS TO SAVE/RECALL*. The relationship between the designations in the table and the contents of the partial data sets is shown in Table 2-2.

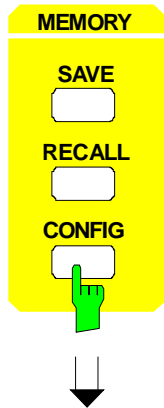
The saved files of the data sets can be copied from one storage medium (e.g. drive C:) to another storage medium (e.g. drive A:) or to another directory using the functions found in the *MEMORY CONFIG* menu. File names and extensions must however not be changed. The relationship between the partial data sets and the extensions is shown in Table 2-2.

Table 2-2 Relationship between file extensions and contents of partial data sets

| | Extension | Contents | Designation in the table SEL ITEMS TO SAVE/RECALL |
|--|------------------|---|--|
| Configuration data: | .SET | current settings of the measurement hardware and the related title, if present | HARDWARE SETTINGS |
| | .LIN | data-point tables for the active limit lines + configuration of the limit line sets | LINES |
| | .CKD | data of the calibration standards which are used | CAL KIT DATA |
| | .CFG | current configuration of general instrument parameters | GENERAL SETUP |
| | .MAC | user-defined macros | |
| | .MNU | user-defined menu configuration | MENU+WINDOWS SETUP |
| | .HCS | configuration for hardcopy output | HARDCOPY |
| | .COL | user-defined color settings and positions of the movable display elements | COLOR SETUP |
| Measurement correction data: | .CAL | calibration data | |
| | .PCA | power meter calibration data | |
| Measurement results: | .TR1...4 | measurement data trace 1 to trace 4 | TRACE1...4 |
| | .M01...xx | measurement data memory trace 1 to xx | |
| Reloadable functional extensions: | .Xxx | configuration data for functional extension xx | |

2.6.1 Configuration of Memory – CONFIG Key

MEMORY CONFIG menu:



The CONFIG key opens a menu for managing storage media and files.

Table DRIVE MANAGEMENT displays the name and label of the storage medium as well as the available storage area.

Table FILE MANAGEMENT displays the files of the current directory and indicates if any subdirectories are present.

If a directory name is selected, the instrument automatically changes to this directory. Selection of the entry '..' moves the instrument to the next higher directory level.

Note: It is not possible to change menus as long as a file operation is running.

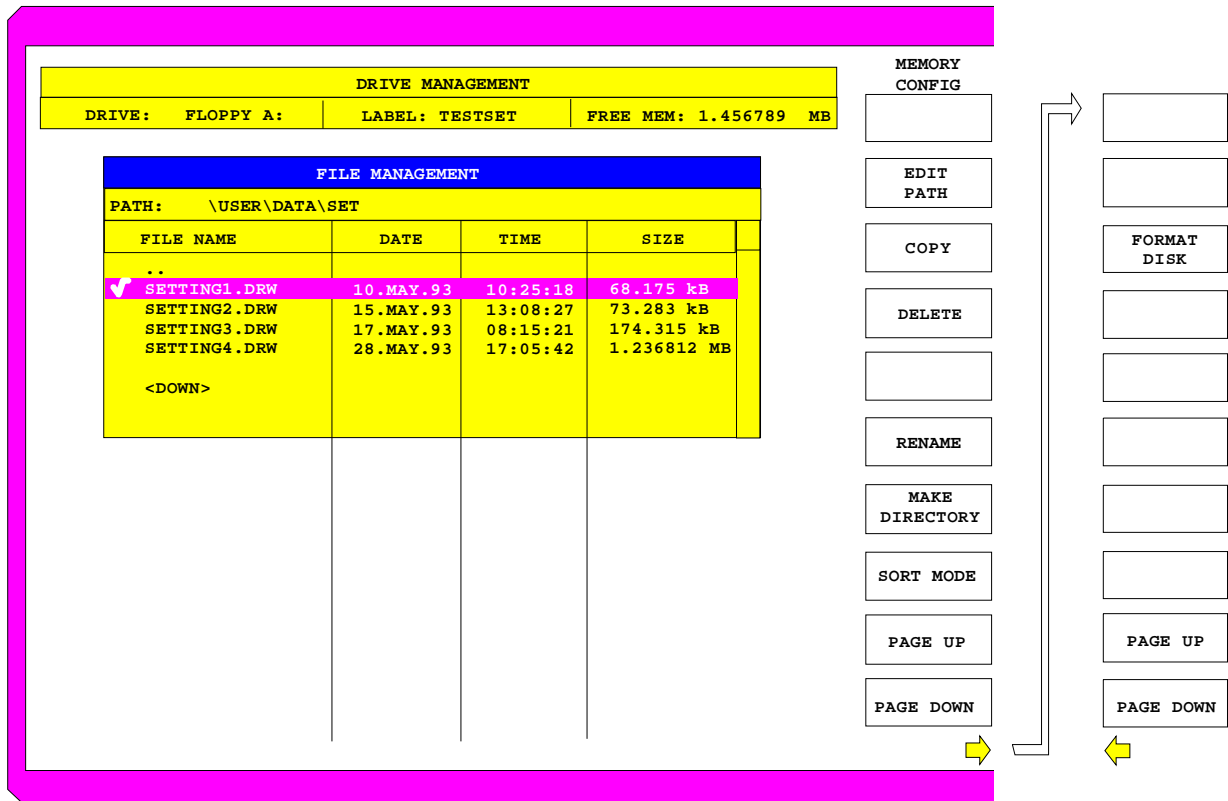
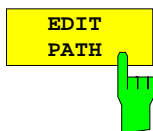
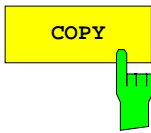


Fig. 2-28 File and storage media management



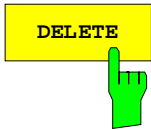
The EDIT PATH softkey activates the input of the directory which will be used in subsequent file operations.

The new path is included in the FILE MANAGEMENT table.



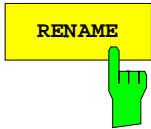
The *COPY* softkey activates the input of the destination of the copy operation.

By entering a predefined disk drive (e.g. C:), a file can also be copied to another storage medium. The files/directories selected by the cursor are copied after the input is confirmed by pressing the *ENTER* key.



The *DELETE* softkey deletes the selected files.

To prevent accidental deletion of data, confirmation by the user is requested.

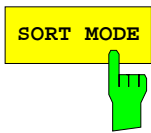


The *RENAME* softkey activates the entry of a new name for the selected file or directory.

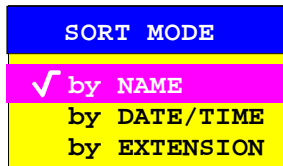


The *MAKE DIRECTORY* softkey creates directories/sub-directories. Sub-directories are recommended for sorting files on the storage medium so that the structure is easier to comprehend.

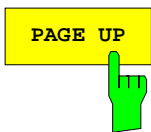
The entry of an absolute path name (e.g.; "USER\MEAS") as well as the path relative to the current directory (e.g., "..\MEAS") is possible.



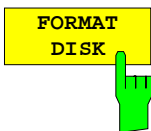
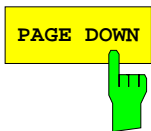
The *SORT MODE* softkey activates the selection of the criteria according to which the files listed in the *FILE MANAGEMENT* table may be sorted.



Directory names are located at the top of the list after the entry for the next higher directory level ("..").



The *PAGE UP* or *PAGE DOWN* softkey sets the *FILE MANAGEMENT* table to the next or the previous page.



The *FORMAT DISK* softkey formats diskettes located in drive A:

To prevent accidental destruction of diskette data, confirmation by the user is requested.

2.6.2 Saving Data Sets – SAVE Key

The SAVE key activates a menu which contains all functions necessary for saving instrument data.

- Entry of the name of the data set which should be saved. Confirmation of the entry initiates a save operation to store the data set.

Data set names may contain both alphabetical and numeric characters, in the simplest case only numbers. The simplest example for the input of a data set name is illustrated by the following key strokes:

<SAVE> <1> <units key>

- Entry of the directory and drive in which the data set is to be saved (*SET PATH...*, *EDIT PATH*).
- Selection of the partial data sets to be saved (submenu *SEL ITEMS TO SAVE*).
- Indication of all available data sets (*DATA SET LIST*).
- Deletion of one or all available data sets.
- Input of data set description (*EDIT COMMENT*).
- Configuration of the ASCII files to be generated.

MEMORY SAVE menu

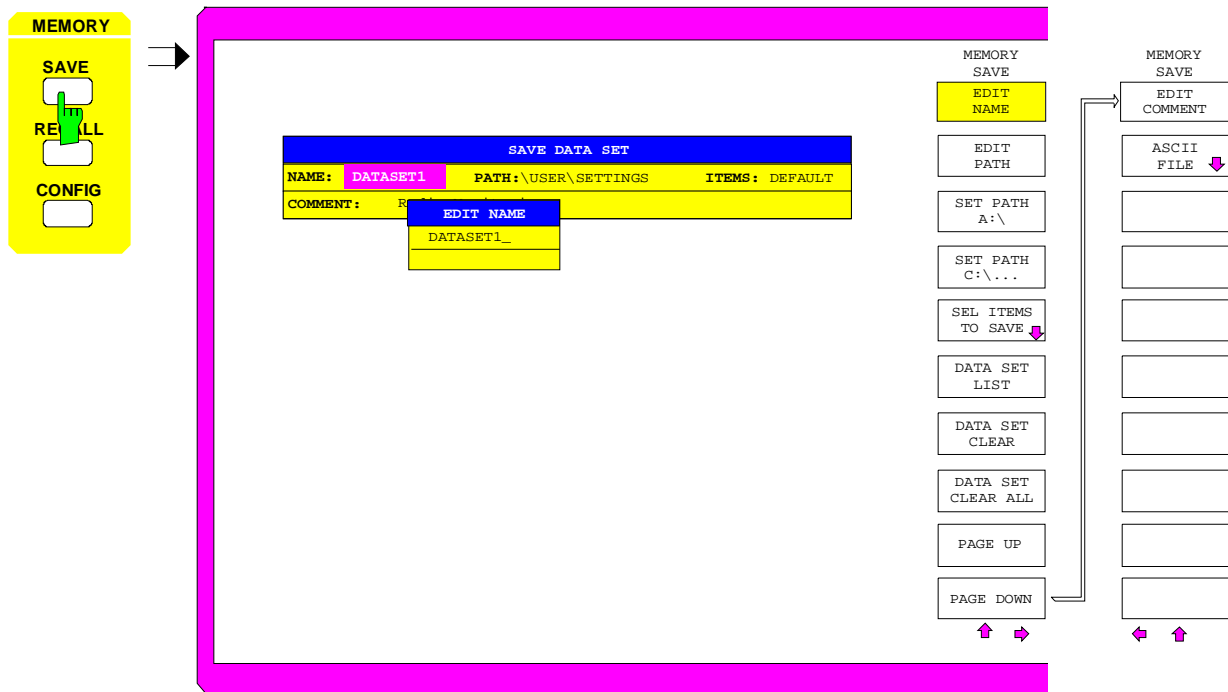


Fig 2-29 Saving data sets

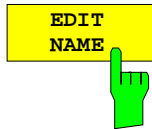
The SAVE DATA SET table shows the current settings regarding the data set:

| | |
|----------------|--|
| <i>Name</i> | name of data set |
| <i>Path</i> | directory in which the data set will be saved |
| <i>Items</i> | indicates whether the default selection of the partial data set (<i>DEFAULT</i>) or a user-defined selection (<i>SELECTED</i>) will be saved |
| <i>Comment</i> | Comment regarding the data set |

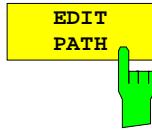
The EDIT NAME softkey for entering the name of the data set to be saved is activated automatically.

2.6.2.1 Selecting the Data Set for Storage

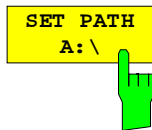
MEMORY SAVE menu:



The *EDIT NAME* softkey activates the entry of the name of the data set to be saved. Data entry is concluded by pressing one of the units keys which initiates a save operation to store the data set.

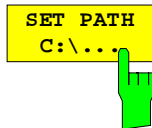


The *EDIT PATH* softkey activates the input of a directory name where the data sets are to be stored.



The *SET PATH A:* softkey determines that the data set is to be stored in drive A (floppy disk).

The drive name is included in the *SAVE DATA SET* table.



The *SET PATH C:\...* softkey determines that the data set is to be stored in drive C (hard disk).

The drive name is included in the *SAVE DATA SET* table.



The *DATA SET LIST* softkey opens the *DATA SET LIST/CONTENTS* table.

| DATA SET LIST | DATA SET CONTENTS | |
|---------------|-------------------|-------------|
| DATASET1 | CONTENTS | |
| DATASET2 | ✓ GENERAL SETUP | MEM TRACE 1 |
| DATASET3 | ✓ COLOR SETUP | MEM TRACE 2 |
| | ✓ HW SETTINGS | MEM TRACE 3 |
| | ✓ HARDCOPY | MEM TRACE 4 |
| | ✓ CAL DATA | MEM TRACE 5 |
| | CAL KIT DATA | MEM TRACE 6 |
| | MACROS | MEM TRACE 7 |
| | LINES | MEM TRACE 8 |
| | ASCII DATA | |
| | COMMENT | |
| | Radio Monitoring | |

The *DATA SET LIST* column lists all of the data sets which are stored in the selected directory.

The *CONTENTS* and *COMMENT* lines in the *DATA SET CONTENTS* column indicate the saved partial data sets and the comment for the currently selected data set.

Note:

The current instrument configuration can be easily stored under the name of an existing data set:

- Press a prefix (unit) key after selecting a data set.
The name and the selection of the partial data sets for the currently selected data set will be placed in the SAVE DATA SET table. The DATA SET LIST table is closed and, instead, the entry field for the EDIT NAME function with the name of the selected data set is opened.
- Press a units key.
The current instrument configuration is saved as a data set under this name.

DATA SET
CLEAR



The *DATA SET CLEAR* softkey deletes the data set selected in the list. Confirmation by the user is required before.

DATA SET
CLEAR ALL



The *DATA SET CLEAR ALL* softkey deletes all data sets in the current directory.

Confirmation by the user is required before.

PAGE UP



The *PAGE UP* or *PAGE DOWN* softkey sets the *DATA SET LIST* table to the next or previous page.

PAGE DOWN



EDIT
COMMENT



The *EDIT COMMENT* softkey activates the entry of comment concerning the current data set. A total of 60 characters are available for this purpose.

2.6.2.2 Selecting the Data Subset for Storage

The *SEL ITEMS TO SAVE* softkey opens a submenu and the table *ITEMS TO SAVE* for selecting a subset of the current data set to be stored.

MEMORY SAVE-SELECT ITEMS TO SAVE submenu:

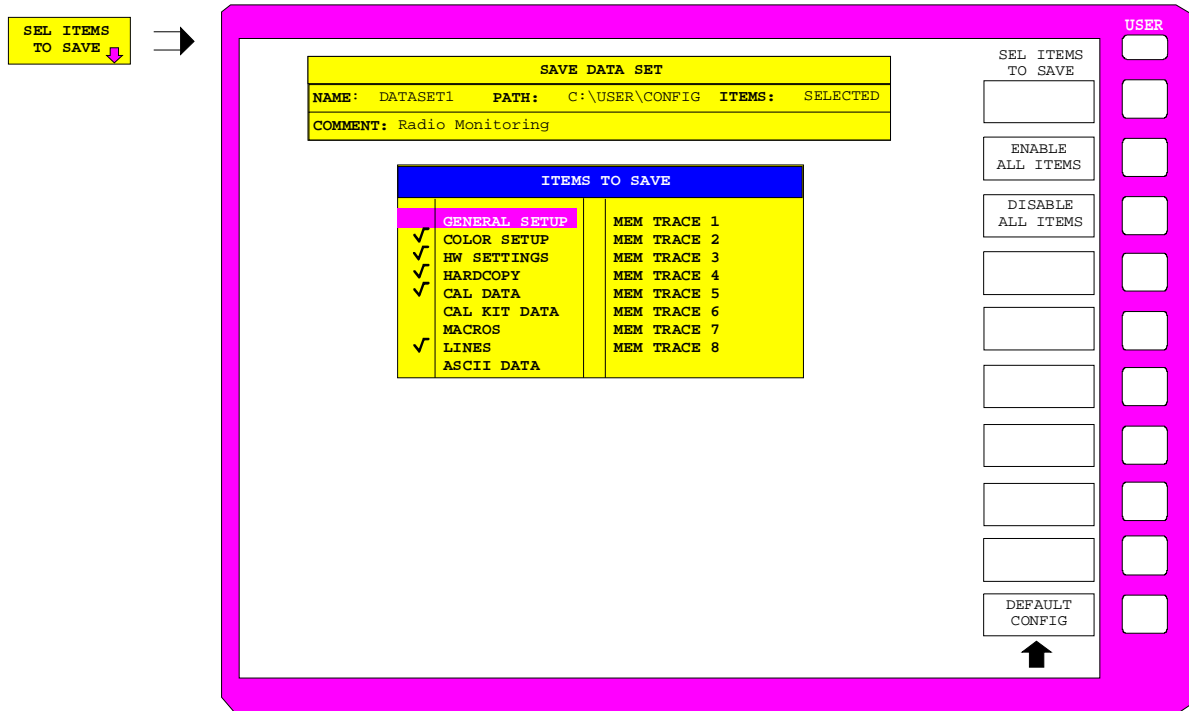
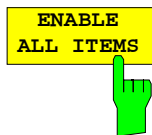


Fig. 2-30 Selecting the data set for storage

In the *ITEMS TO SAVE* table, the following subsets of the current data set can be selected:

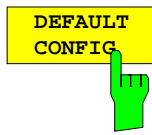
- General Setup* current configuration of general instrument parameters
- HW-Settings* current measurement hardware settings
- Trace1...4* measurement data trace 1 to trace 4
- Lines* data point tables for the active limit lines
- Cal Data* calibration data
- Cal Kit Data* characteristics of the calibration kit
- Menu+Window Setup* user-defined menu settings
- Color Setup* user-defined color settings
- Hardcopy* configuration for hardcopy output



The *ENABLE ALL ITEMS* softkey selects (and checks) all entries in the *ITEMS TO SAVE* table.



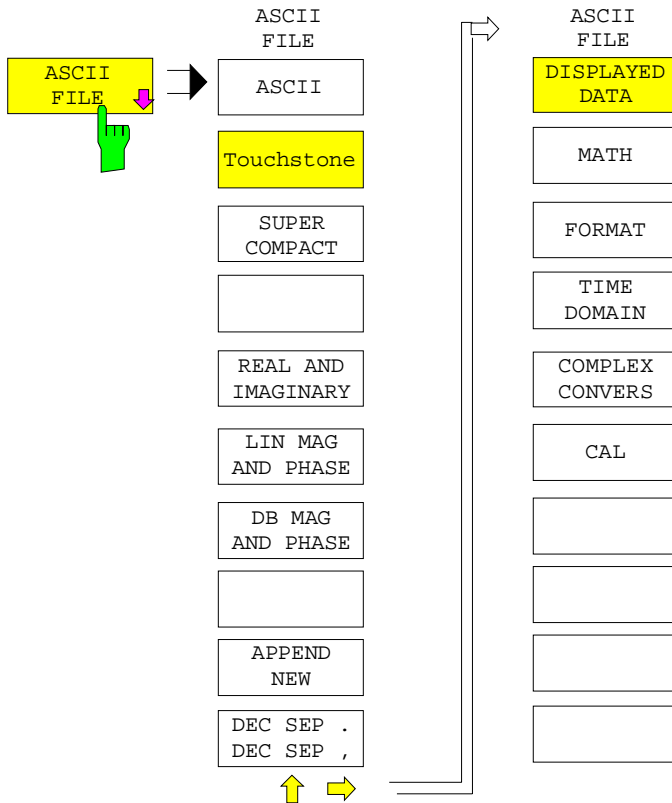
The *DISABLE ALL ITEMS* softkey deselects all entries in the *ITEMS TO SAVE* table.



The *DEFAULT CONFIG* softkey establishes the default selection of the partial data set to be saved and outputs *DEFAULT* in the *ITEMS* field of the *SAVE DATA SET* table.

2.6.2.3 Configuration of ASCII Files

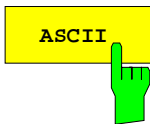
MEMORY SAVE - ASCII FILE submenu:



The *ASCII FILES* softkey opens a submenu used to define the characteristics of the ASCII file to be created.

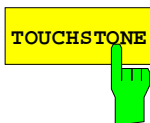
Any ASCII output file can be configured. However, in order to meet the requirements of the SUPER COMPACT and TOUCHSTONE formats, a file in these two formats is generated only if

- either a reflection parameter is measured in the single channel mode
- or all four S, Z or Y parameters are measured in the quadruple channel mode with coupled channels.



The *ASCII* softkey creates an ASCII file which can imported for arbitrary applications. Only the quantity of the active channel is output.

This format does not restrict the quantity to be measured, the channel coupling or the conversion and formatting.

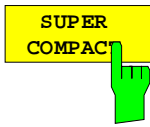


If the *TOUCHSTONE* softkey is selected, the ASCII data are stored in a format compatible with the applications of CAE supplier Agilent EESof®.

- If a reflection factor S_{ii} or a non-normalized Z_{ii} or Y_{ii} is measured when the data is saved, a .S1P, .Z1P or .Y1P file is created.
- If all 4 S-parameters or the non-normalized Z or Y parameters of a two-port are measured in coupled quadruple channel mode (with any allocation to the display channels), a .S2P, .Z2P or .Y2P file is created.
- For other combinations or in decoupled multichannel mode, no file is created.

On pressing the *TOUCHSTONE* softkey, a message is displayed informing the user of the above conditions for a .S1P or .S2P file to be created.

Data obtained in a time or power sweep cannot be stored in the *TOUCHSTONE* format.



If the *SUPER COMPACT* softkey is selected, the ASCII data are stored in a format compatible with the applications of CAE supplier Ansoft®.

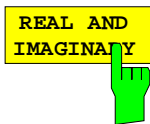
- If a reflection factor S_{ii} or a non-normalized Z_{ii} or Y_{ii} is measured on when the data is saved, a one-port .FLP file is created.
- If all 4 S-parameters or the non-normalized Z or Y parameters of a two-port are measured in coupled quadruple channel mode (with any allocation to the display channels), a two-port .FLP file is created.
- For other combinations or in decoupled multichannel mode, no file is created.

On pressing the SUPER COMPACT softkey, a message is displayed informing the user of the above conditions for a .FLP file to be created in the one-port or two-port format.

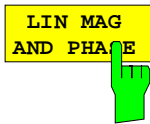
Data obtained in a time or power sweep cannot be stored in the *SUPER COMPACT* format.

The softkey *APPEND NEW* (see below) allows to select whether a new file is created (an existing file may be overwritten) or if the data is appended to the end of an existing file.

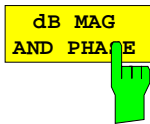
The three following softkeys define the output format of the measured values:



The measured values are represented by their real and imaginary parts.



The measured values are represented by their linear magnitude and phase.



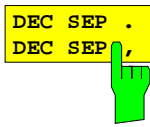
The measured values are represented by their logarithmic magnitude and phase.



The *APPEND NEW* softkey selects whether the output data is written to an already existing file or to a new file.

- In position *APPEND*, the data is appended to an existing file.
- In position *NEW*, either a new file is created or an already existing file is overwritten while the data is saved.

Note: *As TOUCHSTONE does not support appending of data to the end of a file, the APPEND NEW is locked if this output format is selected.*

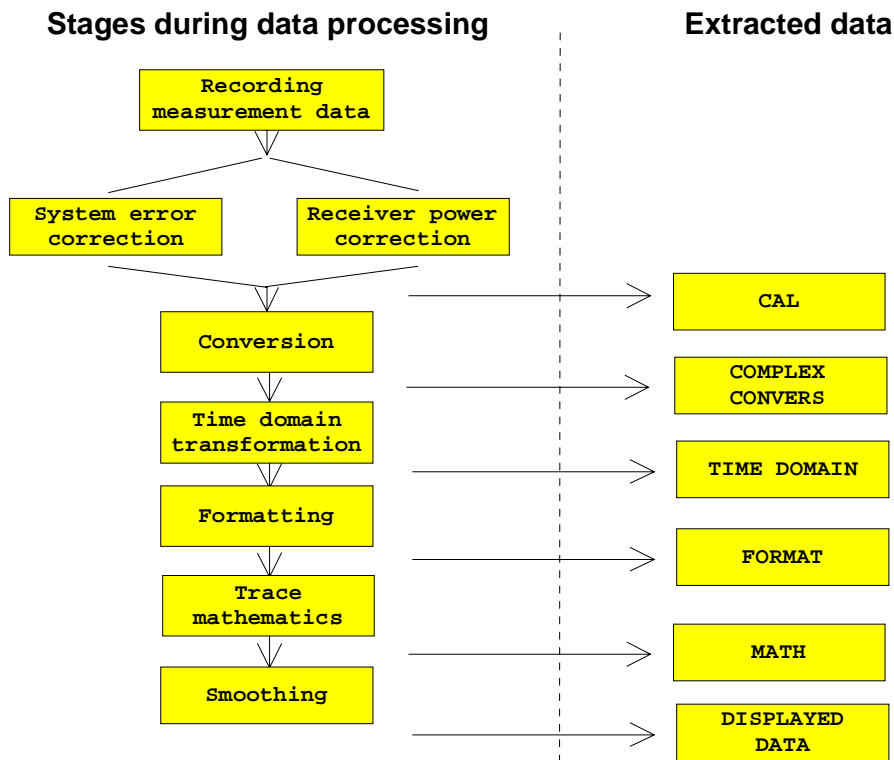


The *DEC SEP* softkey selects the decimal separator for ASCII files. The separator must be selected according to the requirements of the application the ASCII file is intended for.

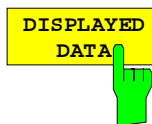
The default setting depends on the language for an external keyboard selected in the SETUP - GENERAL SETUP menu (see section 2.4.2.1.4, External Keyboard Configuration).

For the languages „GERMAN“ and „FRENCH“, the comma (‘,’) is selected, for „US-AMERICAN“ the period (‘.’) is the default separator.

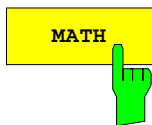
The following diagram shows on which stages in the processing of measured values it is possible to extract data:



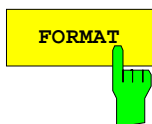
The data required can be selected with the softkeys described in the following.



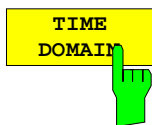
The *DISPLAYED DATA* softkey saves the data in the selected format.



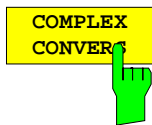
The *MATH* softkey saves the data without applying the possibly activated *SMOOTHING*-function.



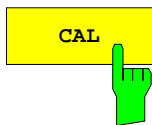
The *FORMAT* softkey saves the data without applying the possibly activated functions *SMOOTHING* and *TRACE MATH*



The *TIME DOMAIN* softkey saves the data without applying the possibly activated functions *SMOOTHING*, *TRACE MATH* and *FORMAT*.



The *COMPLEX CONVERS* softkey saves the data without applying the possibly activated functions *SMOOTHING*, *TRACE MATH*, *FORMAT* and *TIME DOMAIN*.



The *CAL* softkey saves the data without applying the possibly activated functions *SMOOTHING*, *TRACE MATH*, *FORMAT*, *TIME DOMAIN* and *COMPLEX CONVERS*.

2.6.3 Recalling Data Sets – *RECALL* Key

The *RECALL* key activates a menu which contains all functions necessary for recalling data sets.

- Entry of the name of the data set which should be recalled. Confirmation of the entry initiates a load operation to recall the data set.
- Entry of the directory and drive in which the data set is stored.
- Display of data set description.
- Selection of a data set which will be automatically loaded upon power-up.
- Indication of all available data sets.
- Deletion of all available data sets.
- Selection of the partial data sets which should be loaded (configurations, measurement and calibration data, sub-menu *SEL ITEMS TO RECALL*).

Any settings not restored when partial data sets are loaded will remain unchanged in the instrument. During recall operations, the instrument recognizes which partial data sets are present in the recalled data set and offers only the corresponding settings for selection in the *SEL ITEMS TO RECALL* sub-menu.

A new instrument data set can be easily constructed from several existing data sets:

1. The desired partial data sets are selected and recalled out of various data sets in several *RECALL* operations. When the desired configuration is completed, the new data set can be saved under a new name (*SAVE* menu).
2. The files of the desired partial data sets are copied (*MEMORY CONFIG* menu), whereby the new name (= the name of the new data set) is used for each of the copied files. The file extension is however not changed. When the copy procedure has terminated, the new data set can be loaded into the instrument (*RECALL* menu, *SEL ITEMS TO RECALL* submenu).

Note:

The second method may under certain conditions be quicker, but it involves the risk that data sets are constructed whose elements are incompatible. With the first method, a check is performed after each load operation as to whether the restored data are compatible with the rest of the instrument settings and warnings and error messages are generated if the case may be. With the second method, the information regarding the relationship between partial data sets and generated messages is lost. It then becomes very difficult to locate the partial data set which is incompatible with the others.

MEMORY RECALL menu:

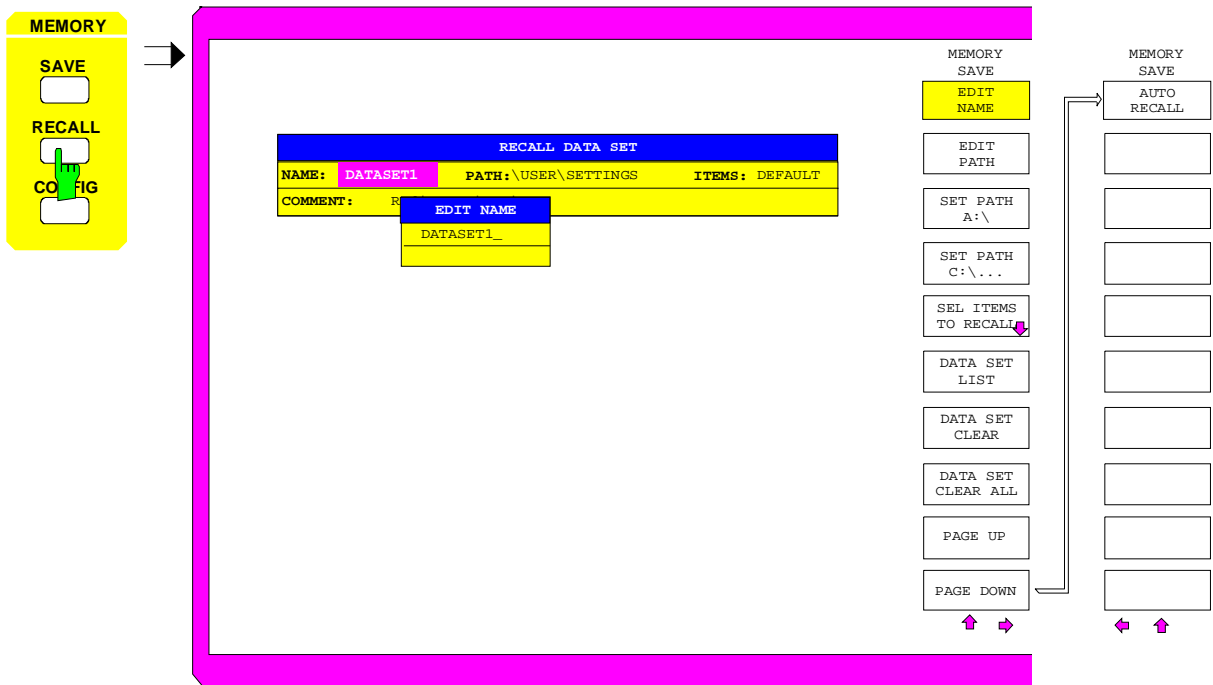


Fig. 2-31 Recalling data sets

The *RECALL DATA SET* table shows the current settings regarding the data set:

| | |
|----------------|---|
| <i>Name</i> | name of data set |
| <i>Path</i> | directory in which the data set is located |
| <i>Items</i> | indicates whether the default selection of the partial data set (<i>DEFAULT</i>) or a user-defined selection (<i>SELECTED</i>) will be loaded |
| <i>Comment</i> | comment regarding the data set |

The *EDIT NAME* softkey for entering the name of the data set to be loaded is activated automatically.

2.6.3.1 Selecting the Data Set to be Recalled

MEMORY RECALL menu:

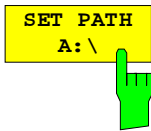


The *EDIT NAME* softkey activates the entry of a data set name. The data input is terminated by pressing one of the units keys which simultaneously initiates the data set recall operation.



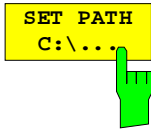
The *EDIT PATH* softkey activates the entry of a directory name in which the data set is located.

The new path is included in the *SAVE DATA SET* table.



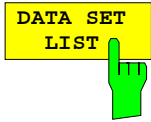
The *SET PATH A:* softkey determines that the data set is called from drive A (floppy disk).

The name of the drive is included in the *RECALL DATA SET* table.

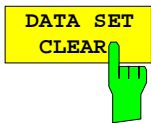


The *SET PATH C:\...* softkey determines that the data set is called from drive C (hard disk).

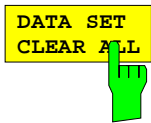
The name of the drive is included in the *RECALL DATA SET* table.



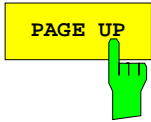
see Chapter "Saving Data Sets".



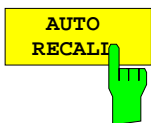
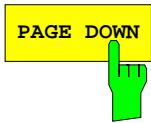
see Chapter "Saving Data Sets"



see Chapter "Saving Data Sets".



The *PAGE UP* or *PAGE DOWN* softkey sets the *DATA SET LIST* table to the next or previous page.



The *AUTO RECALL* softkey activates the selection of a data set which is automatically loaded when the instrument is powered on. To this end the table *DATA SET LIST/CONTENTS* is opened (analogous to *DATA SET LIST*).

| DATA SET LIST | AUTO RECALL CONTENTS | | | | | | | | | | | | | | |
|---|--|---|--|---|--|---|---|---|---|---|------------------|---|--|---|-----------------|
| <input checked="" type="checkbox"/> FACTORY DATA SET1 DATASET2 DATASET3 | ▲ PATH : \USER\SETTINGS CONTENTS <table border="0"> <tr> <td><input checked="" type="checkbox"/> GENERAL SETUP</td> <td><input checked="" type="checkbox"/> CAL DATA</td> </tr> <tr> <td><input checked="" type="checkbox"/> HW-SETTINGS</td> <td><input checked="" type="checkbox"/> CAL KIT DATA</td> </tr> <tr> <td><input checked="" type="checkbox"/> TRACE 1</td> <td><input checked="" type="checkbox"/> MENU+WINDOW SETUP</td> </tr> <tr> <td><input checked="" type="checkbox"/> TRACE 2</td> <td><input checked="" type="checkbox"/> COLOR SETUP</td> </tr> <tr> <td><input checked="" type="checkbox"/> TRACE 3</td> <td>EXTENSION CONFIG</td> </tr> <tr> <td><input checked="" type="checkbox"/> TRACE 4</td> <td></td> </tr> <tr> <td><input checked="" type="checkbox"/> LINES</td> <td>SYSTEM MESSAGES</td> </tr> </table> COMMENT Radio Monitoring | <input checked="" type="checkbox"/> GENERAL SETUP | <input checked="" type="checkbox"/> CAL DATA | <input checked="" type="checkbox"/> HW-SETTINGS | <input checked="" type="checkbox"/> CAL KIT DATA | <input checked="" type="checkbox"/> TRACE 1 | <input checked="" type="checkbox"/> MENU+WINDOW SETUP | <input checked="" type="checkbox"/> TRACE 2 | <input checked="" type="checkbox"/> COLOR SETUP | <input checked="" type="checkbox"/> TRACE 3 | EXTENSION CONFIG | <input checked="" type="checkbox"/> TRACE 4 | | <input checked="" type="checkbox"/> LINES | SYSTEM MESSAGES |
| <input checked="" type="checkbox"/> GENERAL SETUP | <input checked="" type="checkbox"/> CAL DATA | | | | | | | | | | | | | | |
| <input checked="" type="checkbox"/> HW-SETTINGS | <input checked="" type="checkbox"/> CAL KIT DATA | | | | | | | | | | | | | | |
| <input checked="" type="checkbox"/> TRACE 1 | <input checked="" type="checkbox"/> MENU+WINDOW SETUP | | | | | | | | | | | | | | |
| <input checked="" type="checkbox"/> TRACE 2 | <input checked="" type="checkbox"/> COLOR SETUP | | | | | | | | | | | | | | |
| <input checked="" type="checkbox"/> TRACE 3 | EXTENSION CONFIG | | | | | | | | | | | | | | |
| <input checked="" type="checkbox"/> TRACE 4 | | | | | | | | | | | | | | | |
| <input checked="" type="checkbox"/> LINES | SYSTEM MESSAGES | | | | | | | | | | | | | | |

The *DATA SET LIST* column displays all data sets present in the selected directory.

The *CONTENTS* and *COMMENT* lines in the *AUTO RECALL CONTENTS* column indicate the saved partial data sets and the comment for the currently selected data set.

In addition to the data sets stored by the user, the data set *FACTORY*, which specifies the settings of the instrument before it was last switched off (Standby), is always present.

If a data set other than *FACTORY* is chosen then, at the time of instrument power on, the available partial data sets of the selected data set are recalled. The partial data sets which are not present in this data set are taken from the *FACTORY* data set.

2.6.3.2 Selecting Data Subsets to be Recalled

The *SEL ITEMS TO RECALL* softkey opens a submenu for selecting a subset of the current data set to be recalled.

MEMORY RECALL-SELECT ITEMS TO RECALL submenu:

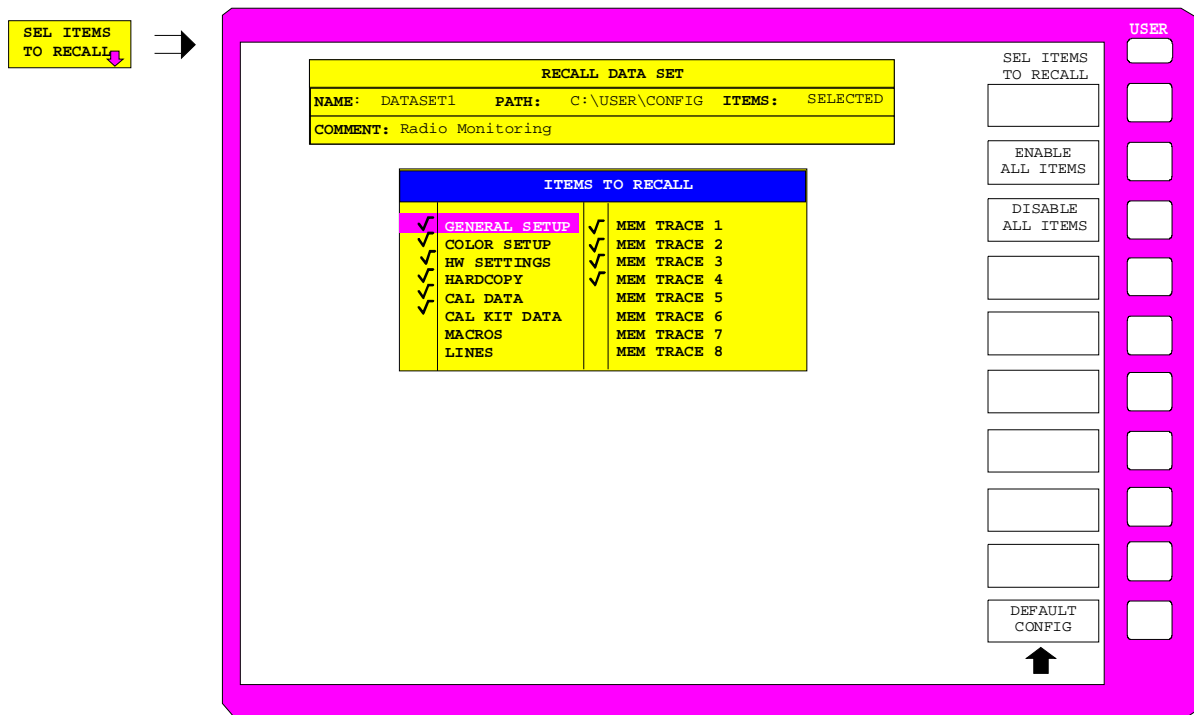


Fig. 2-32 Selecting partial data sets to be recalled

The *ITEMS TO RECALL* selection table lists the partial data sets available:

| | |
|--------------------------|--|
| <i>General Setup</i> | current configuration of general instrument parameters |
| <i>HW-Settings</i> | current measurement hardware settings |
| <i>Trace1...4</i> | measurement data trace 1 to trace 4 |
| <i>Lines</i> | data point tables for the active limit lines |
| <i>Cal Data</i> | calibration data |
| <i>Cal Kit Data</i> | characteristics of the calibration kit |
| <i>Menu+Window Setup</i> | user-defined menu settings |
| <i>Color Setup</i> | user-defined color settings |
| <i>Hardcopy</i> | configuration for hardcopy output |

ENABLE
ALL ITEMS



The *ENABLE ALL ITEMS* softkey selects (and checks) all entries in the *ITEMS TO RECALL* table.

DISABLE
ALL ITEMS



The *DISABLE ALL ITEMS* softkey deselects all entries in the *ITEMS TO RECALL* table.

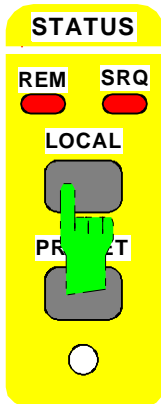
DEFAULT
CONFIG



The *DEFAULT CONFIG* softkey establishes the default selection of the partial data set to be recalled and outputs *DEFAULT* in the *ITEMS* field of the *RECALL DATA SET* table.

2.7 Switchover to Manual Operation and Default Setup – STATUS Group

2.7.1 Switchover to Manual Operation – LOCAL Key



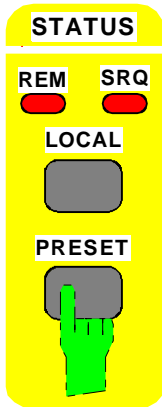
The *STATUS* group comprises the *SRQ* and *REMOTE* LEDs and the *LOCAL* key.

- The *SRQ* LED indicates that the instrument has raised a service request on the IEC/IEEE bus.
- The LED *REMOTE* LED indicates that the instrument is in remote control.
- The *LOCAL* key switches the instrument from remote to manual control provided the remote controller has not activated the LOCAL LOCKOUT function.

Changing to manual control results in:

- **Enabling the front-panel keys**
Under remote control, the softkey menu is turned off and all keys, with the exception of *PRESET* and *LOCAL*, are disabled. Returning to manual mode enables all inactive keys. The softkey menu displayed is the main menu of the current operating mode.
 - **Turning off the *REMOTE* LED**
 - **Generating the OPERATION COMPLETE message**
If, at the time of pressing the *LOCAL* key, synchronization via **OPC*, **OPC?* or **WAI* is active, the current measurement is aborted and synchronization is achieved by setting the corresponding bits in the registers of the status reporting system.
 - **Setting bit 6 (User Request) in the Event Status Register**
With a corresponding configuration of the status reporting system, this bit causes the generation of a service request (*SRQ*) which is used to inform the controller that the user wishes to return to front-panel control. This information can be used, e.g. to interrupt the control program so that the user can make necessary manual corrections to instrument settings. This bit is set each time the *LOCAL* key is pressed irrespective of whether the instrument is under remote or manual control.
- The *LOCAL* key aborts a running macro. Macros cannot be continued.

2.7.2 Default Setup – PRESET Key



The *PRESET* key restores the default setup. All current settings are thereby lost.

To avoid the inadvertent switch-on of this function, a query is displayed each time the *PRESET* key is pressed. If resetting is confirmed with OK, the default setup is restored. If the preset should not be carried out, CANCEL has to be pressed. This, for instance, allows the current instrument setup to be stored with the aid of the MEMORY SAVE functions for subsequent call-up.

After pressing the *PRESET* key and subsequent confirmation, the instrument carries out a default setup according to the table below. Remember especially for sensitive EUTs that the output level at the ports is -10 dBm.

Table 2-3 PRESET settings

| Parameter | Setting |
|---|--|
| Active channel | CH1 |
| Magnitude | S ₁₁ |
| Conversion of measured value | S (selected s parameter is not converted) |
| Reference impedance Z ₀ | 50 Ω or 75 Ω (depending on TEST SET of instrument) |
| Formatting the selected complex magnitude | Complex |
| Aperture for group-delay measurement | 10 test points |
| Relative dielectric constant ε _r (EPSILON) | 1 |
| Maximum on radial axis | 1 |
| Diagram | SMITH |
| Display mode | SINGLE CHANNEL |
| Curve data | Currently measured data (not linked to stored data) |
| System error correction | Switched off |
| Offset | 0 |
| Start frequency | 9 kHz (ZVR, ZVRE, ZVRL with passive bridges) 300 kHz (ZVR, ZVRE, ZVRL with active bridges) 20 kHz (ZVC, ZVCE) 10 MHz (ZVK, ZVM) |
| Stop frequency | 4 GHz (ZVR, ZVRE, ZVRL) 8 GHz (ZVC, ZVCE) 20 GHz (ZVK, ZVM) |

| Parameter | Setting |
|--|-----------------------|
| Center frequency | As appropriate |
| Sweep width | As appropriate |
| Sweep mode | Frequency sweep |
| Scale of measured values | Linear |
| Number of test points | 401 |
| Trigger mode | Free-running |
| Sweep direction | Forward |
| Sweep | Enabled |
| Parameters to be coupled | Coupled |
| Sweep | Automatic, continuous |
| Output level | -10 dBm |
| Rise of output level | 0 dB/GHz |
| Sweep time | Automatic |
| Bandwidth of IF filters | 10 kHz |
| IEC/IEEE-bus status of external generators | LOCAL |

2.8 Macros – USER Key

The menus of the network analyzer are so designed that the analyzer can be easily applied to most of the usual measurement tasks with a minimum number of key operations. However, the *USER* menu also permits a tailored adaptation of any necessary setup and measurement functions needed for special applications. Here, a sequence of key operations, which may occur repeatedly, can be listed in the *USER* menu as a key macro, then stored in memory and recalled as required by the application.

2.8.1 Fundamentals

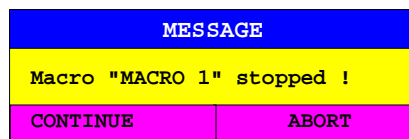
Macros are defined as arbitrary key sequences which need to be defined only once and then can be recalled as often as desired. Through the use of macros, often-needed measurement functions or instrument setups, which may require a large number of key operations, can be easily performed. The writing of macros is possible only under manual control. Macro generation is not possible under remote control (e.g. via the IEC Bus interface).

A total of 27 different macros can be programmed and assigned to the individual softkeys of the *USER* menu. Macros 1 to 7 are contained in the main menu, the remaining 20 can be found in the right and left supplementary menus. Each macro has a title (arbitrarily defined by the user) which is also used as a label for the corresponding softkey. To indicate that a macro has not yet been programmed, the softkey label appears in parenthesis (e.g. (MACRO 1)). After a key-sequence macro has been defined, the parenthesis are removed and the softkey is replaced by the title specified by the user.

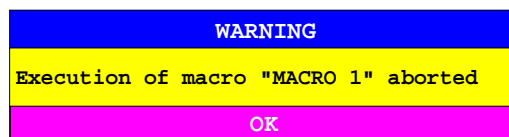
Macro contents can be output as listings and edited. Using the functions in the *MEMORY-SAVE* and *MEMORY-RECALL* menus, macros can be saved to and recalled from the hard disk and floppies.

A macro is executed by pressing the corresponding softkey.

During execution of macros, the key actions are repeated in exactly the **same order** as they were programmed. The sequential execution of a macro may be interrupted by using the *PAUSE* instruction. As soon as a macro is interrupted, adjustments on the Unit Under Test (UUT) may be made, etc. The interrupted macro is allowed to continue by pressing *CONTINUE* in the message window and is aborted by pressing *ABORT*.



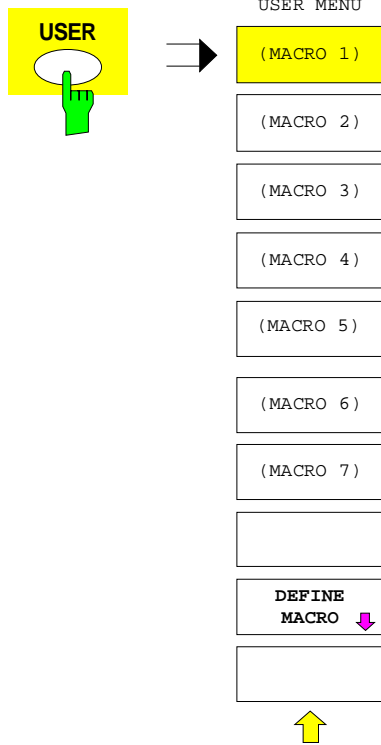
A running macro can be aborted by pressing the *LOCAL* key. At this time, the following message is displayed:



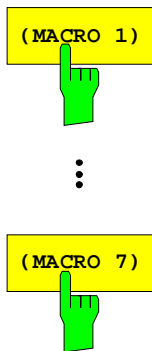
During the time a macro is executing, manual operations on the instrument are not possible, and the softkey panel is disabled. After interruption or conclusion of a macro, the applicable softkey panel is enabled (i.e., menu state at the conclusion of the macro).

2.8.2 Starting Macros

USER menu



The USER key opens a menu for selection and starting of macros. The macros can be defined in the *DEFINE MACRO* submenu.

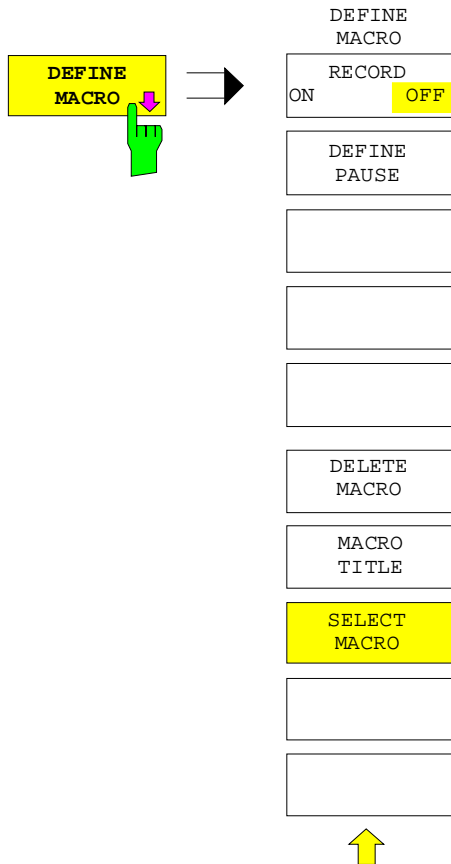


The *MACRO 1* to *7* softkeys start the execution of the associated macros.

2.8.3 Defining Macros

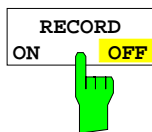
The *DEFINE MACRO* menu contains all of the softkeys which are needed for macro management. Included are functions for starting and ending macro programming, editing of a macro title, etc.

USER DEFINE MACRO menu



The *DEFINE MACRO* softkey calls the sub-menu to define the macros.

The *SELECT MACRO* softkey is active and opens the box to select the macro to be edited. In case no selection is made, *MACRO 1* is automatically selected.

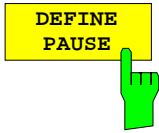


The *RECORD ON/OFF* starts or stops the recording of the macro.

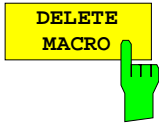
ON All key actions are recorded until the softkey is changed to *OFF*. To indicate that macro record is enabled, the enhancement label **MAC** is displayed.

The number of actions which can be stored in a macro is limited. If the limit is exceeded, the error message "Macro too long. Recording aborted" is output and the recording operation is aborted, however, the actions already recorded do remain stored.

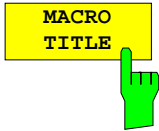
OFF The recording is stopped. The key actions are stored under the macro chosen by the *SELECT MACRO* softkey.



The *DEFINE PAUSE* softkey inserts a pause instruction into the macro sequence which is being recorded. A running macro will pause when it reaches this instruction, at which point settings on the unit under test could for example be made. *CONTINUE* in the message window is used to continue the macro execution.

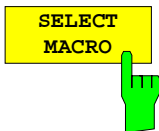


The *DELETE MACRO* softkey deletes the macro which was previously selected by the *SELECT MACRO* softkey. The softkey of the deleted title now carries its default label (*MACRO X*, X = macro number). After the macro has been deleted, its listing is blank.

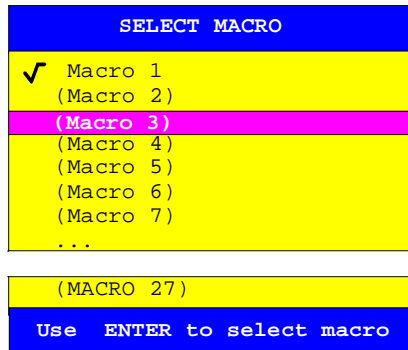


The *MACRO TITLE* softkey activates the entry of the title for the selected macro.

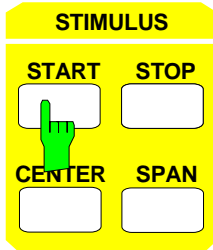
Because the macro title is used for labeling the corresponding softkey, a maximum of only 20 characters is allowed. All text after the 10th character is written to the second line. However, entering the character @ forces a new line at any point in the softkey title.



The *SELECT MACRO* softkey opens the selection box with a list of all 27 macros. All softkey functions of this menu are related to this macro. The listing of the selected macro is displayed on the screen.



2.9 Defining the Sweep Range – STIMULUS Key Group (START, STOP, CENTER and SPAN Keys)



The *STIMULUS* key group comprises the *START*, *STOP*, *CENTER* and *SPAN* keys. These keys activate the entry of the limits and size of the sweep range.

The selection of the sweep variable is made in the *SYSTEM MODE - SWEEP TYPE* menu. Three different sweep modes are available:

- *FREQUENCY SWEEP* sweep over the frequency of the internal source.
- *TIME SWEEP* sweep over the time.
- *POWER SWEEP* sweep over the level of the internal source

With single-point measurement (*SWEEP SWEEP - SINGLE POINT*), the *START*, *STOP* and *CENTER* keys can also be used to enter the stimulus value. The *SPAN* key is inoperative.

When a sweep list is active (*SWEEP SWEEP - LIST SWEEP*), the four keys of the *STIMULUS* key GROUP are inoperative.

The function and input parameters of the *START*, *STOP*, *CENTER* and *SPAN* keys depend on the sweep mode. They are collected in Table 2-4 in the format *parameter [dimension]*.

Table 2-4 Input parameters of the *START*, *STOP*, *CENTER* and *SPAN* key

| | START | STOP | CENTER | SPAN |
|---------------------------------|----------------------|----------------------------|----------------------------------|----------------------------|
| FREQUENCY SWEEP | Start frequency [Hz] | Stop frequency [Hz] | Center frequency [Hz] | Frequency span [Hz] |
| TIME SWEEP | – | total sweep time [h:min:s] | half of the sweep time [h:min:s] | total sweep time [h:min:s] |
| POWER SWEEP | Start level [dBm] | Stop level [dBm] | Center level [dBm] | Level span [dB] |
| Single point measurement | Stimulus value | Stimulus value | Stimulus value | – |
| Sweep list | – | – | – | – |

Notes:

- In the power sweep mode, the *START*, *STOP* and *CENTER* entry fields indicate the generator powers at the test ports with the current attenuation of the generator step attenuators taken into account. If power calibration is active for a port, one of the generator power values refers to the reference plane of calibration, the other value is the uncalibrated nominal power of the other port and is marked *UNCAL*. The sweep range displayed below the measuring diagram applies to the test port that supplies the stimulus for the test parameter in the active display channel (for example *PORT 1* for *S₁₁*). For the sweep range, any generator power calibration or attenuation of the generator step attenuators that may be active is taken into account.
- The *ARBITRARY* mode of option *ZVR-B4* (see section 2.4.1.3.3) allows different frequency ranges for the internal generator, up to two external generators and the *ZVx* receiver for measurements on frequency-converting DUTs. The principle for the configuration of such measurements consists in

deriving these system frequencies from a base frequency using a formula. This base frequency is entered via the *STIMULUS START / STOP* or *CENTER / SPAN* keys. For scaling the sweep axis of the measurement diagram, it is possible to select the base frequency and also one of the configured system frequencies. In this case, note that the frequencies entered with the keys of the *STIMULUS* group still refer to the BASE FREQUENCY. The values for *START / STOP* or *CENTER / SPAN* may therefore differ from the corresponding scaling values in the sweep line or in the measurement diagram. In the *DEF ARBITRARY* menu or if the ARBITRARY mode is activated, a message is displayed in the entry field indicating that the value refers to the BASE FREQUENCY, and the frequency range used for scaling the sweep axis.

In the *TIME SWEEP* mode, the entry of *STOP*, *CENTER* and *SPAN* is made according to the hours:minutes:seconds format in a special entry field.

| START | | |
|------------------------|-----|-------------|
| 0 | HRS | 0 MIN 0 SEC |
| SYSTEM CLOCK: 12:23:56 | | |

The times entered always refer to the respective sweep start. The *START* key has no function, since the sweep always starts immediately upon termination of the entry or immediately following the termination of the previous sweep. A reference to the absolute system clock time can be made via the real-time trigger source (*SWEEP SWEEP - DEFINE TRIGGER - REAL TIME CLOCK*).

In the *POWER SWEEP* mode, the absolute levels *START*, *STOP* and *CENTER* are input in units of dBm. The span, i.e., the difference of two logarithmic values, is entered in dB.

In all modes, the sweep goes over a real interval (*SPAN* ≠ 0). In order to perform a discrete measurement with just one stimulus value, the function *SWEEP SWEEP - SINGLE POINT* must be used.

If the sweep range is changed, the validity of some of the other settings is checked by the instrument. See the descriptions of the hard- and softkeys *SWEEP SWEEP - LOG SWEEP*, *SWEEP AVG - IF BANDWIDTH*, *RESPONSE FORMAT - FREQUENCY APERTURE*, *RESPONSE SCALE - ZOOM*, *RESPONSE TRACE - SHOW MATH* and *CAL CAL*.

For each of the three sweep modes (frequency, time and power sweep), the settings made in the *STIMULUS* and *SWEEP* key groups and the marker values are stored separately. If, e.g., one changes from a frequency sweep to a time sweep and then back to the frequency sweep, the original parameters are restored, regardless of the settings made in the time sweep mode.

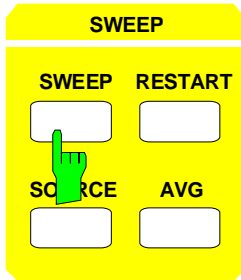
In linear cartesian diagrams; the vertical grid lines depend on the type of entry of the sweep limits:

- If *START* or *STOP* values are entered, the partition lines lie on integer multiples of the grid increment.
- If *CENTER* or *SPAN* is specified, the division is symmetrical to the center of the diagram.

According to the last entry, either the *START* and *STOP* values or the *CENTER* and *SPAN* values are shown below all diagrams.

2.10 Sweep Setup – SWEEP Key Group

The *SWEEP* key group comprises the *SWEEP*, *RESTART*, *SOURCE* and *AVG* keys. These keys define the sweep mode in detail.



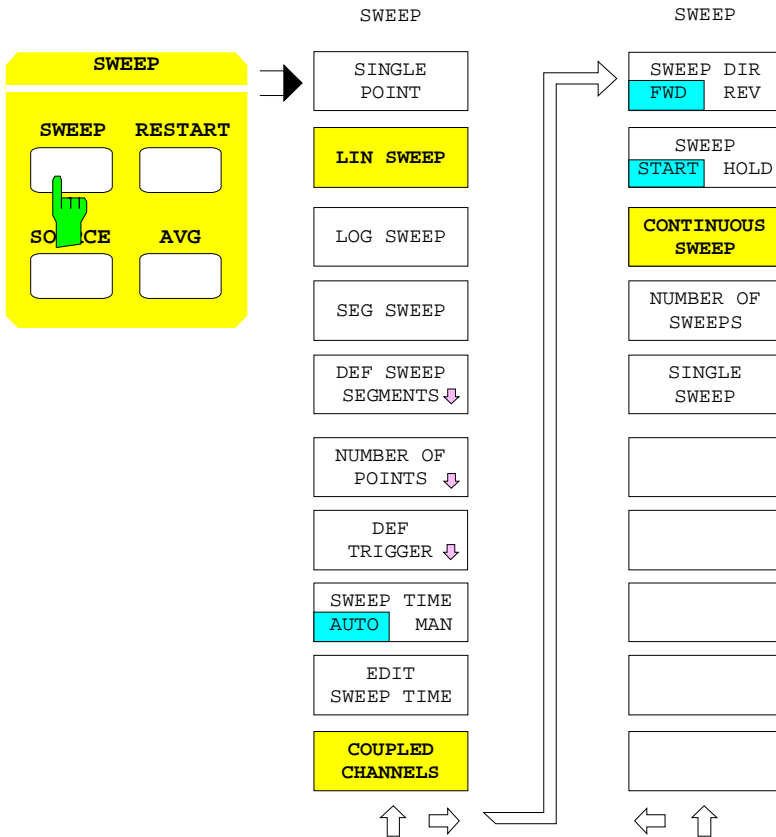
- The *SWEEP* key opens a menu setting parameters for the sweep in the active display channel.
- The *RESTART* key interrupts the sweep period currently active and restarts a new sweep at the start value.
- The *SOURCE* key opens a menu setting the fixed parameters of the sweep.
- The *AVG* key opens a menu setting parameters for the measurement channel bandwidth and the averaging procedure.

2.10.1 Settings for the Sweep Variable – SWEEP Key

The *SWEEP* key opens a menu defining the sweep in the active display channel. The selection of the sweep variable is made in the *MODE - SWEEP TYPE* menu. Test parameters can be displayed as a function of the frequency or power of the signal generator or over the time.

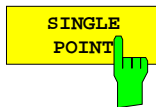
- Single point measurement can be performed in the frequency and power sweep modes (*SINGLE POINT*).
- A time sweep can only be performed in a linear grid (*LIN SWEEP*).
- Frequency and power sweeps may be performed in a linear or logarithmic (*LOG SWEEP*) grid.
- In the frequency sweep mode, an arbitrary grid can be chosen (*SEG SWEEP*) and the parameters can be defined in a special submenu (*DEF SEGMENT LIST*).
- The number of points can be set as required up to a maximum number of 2001 (with one channel) (*NUMBER OF POINTS*).
- Various trigger sources can be selected for sweeps or for single point measurement (*DEF TRIGGER*).
- A sweep may either be performed in the shortest possible time or the time is predefined by the user (*SWEEP TIME AUTO/MAN, EDIT SWEEP TIME*).
- The user may select whether setting parameters such as start and stop values of the sweep range, apply for all of the four display channels (*COUPLED CHANNELS*), or whether they are channel-specific.
- Sweeping is possible in forward or reverse direction (*SWEEP DIR FWD/REV*).
- The sweep may be interrupted and continued again at any time (*SWEEP START/HOLD*).
- Finally, the number of sweeps can be limited to a specific number (*NUMBER OF SWEEPS*) or to 1 (*SINGLE SWEEP*).

SWEEP SWEEP menu:



2.10.1.1 Single Point Measurement

SWEEP SWEEP menu:



The *SINGLE POINT* softkey switches over to single point measurement.

The sweep variable is then kept to a constant value. The latter is entered via the *START*, *STOP* and *CENTER* keys of the *STIMULUS* group. It is independent of the sweep range for the *LIN SWEEP* and *LOG SWEEP* grids. In Cartesian diagrams, the measured value is displayed as horizontal line and the partition of the x-axis disappears. In polar diagrams the measured value is displayed as a cross.

A single point measurement is possible for frequency or power sweeps only. It can not be performed in the *TIME SWEEP* mode.

Some of the keys in the *SWEEP* menu refer to the sweep mode nominally but can be used for single point measurement as well (see below, *SWEEP START/HOLD*, *NUMBER OF SWEEPS*, *SINGLE SWEEP*).

2.10.1.2 Defining the grid

SWEEP SWEEP menu:



The *LIN SWEEP* softkey sets a grid with constant step size. This is the default setting.

The grid depends on the sweep range and the number of points specified in the *NUMBER OF POINTS* menu. With Cartesian diagrams, the instrument switches to linear scaling of the x-axis. A single, dual or fifth-division scaling is superimposed on the sweep range such that approx. 10 division lines are obtained.

The position of these division lines is not predefined but depends on the integer multiple of the division increment in the absolute-value range of the sweep variable.



The *LOG SWEEP* softkey sets a logarithmic grid.

This is defined by the sweep range and the number of test points similar to *LIN SWEEP*. With Cartesian diagrams, the instrument switches over to a logarithmic scaling of the x-axis, simultaneously.

Partition lines are generated in steps of one between two octaves and two decades and in steps of two with more than 2 decades. The position of the partition lines depends on the absolute values of the sweep variable.

A logarithmic grid (*LOG SWEEP*) is available in the frequency and power sweep modes.

Note: *If the sweep range covers less than 2 octaves, LOG SWEEP can not be activated.*



The *SEG SWEEP* softkey activates the setting of a grid using the *DEF SWEEP SEGMENTS* submenu.

This is possible if the currently valid sweep list contains at least two points. In the *LIST SWEEP* mode, those parameters which can be specified within the segment list (sweep range limits, number of points, power, sweep time, averaging factor and IF bandwidth) can no longer be set via the respective hard- and softkeys.

Defining a segment list via *SEG SWEEP* is possible in the frequency sweep mode only (*SYSTEM MODE - FREQUENCY SWEEP*).

The segmentation of the frequency axis can also be useful for performing power calibration for frequency-converting measurements. See section 2.15.1.4.

The *DEF SWEEP SEGMENTS* softkey opens a submenu for editing the sweep list.

This list allows to divide the sweep range into up to 40 individual segments each of which can be interpreted as an independent sweep range with individual setting of the most important generator and receiver parameters.

Using a segment list is suitable for a number of different applications.

- If the properties of a DUT at explicitly specified, not equidistant points are to be examined, then segments with one single point only can be entered.
- Frequently, a higher density of measuring points is required in specific domains of the sweep range, such as at filter skirts. Therefore, segments with different numbers of points which need not be adjacent or overlap can be defined.
- It is even possible to mask out negligible domains for making better use of the diagram width.

Similar functions are provided in the menu of the *DIAGRAM* key for the segmented scaling of the parameter axis in Cartesian and polar diagrams.

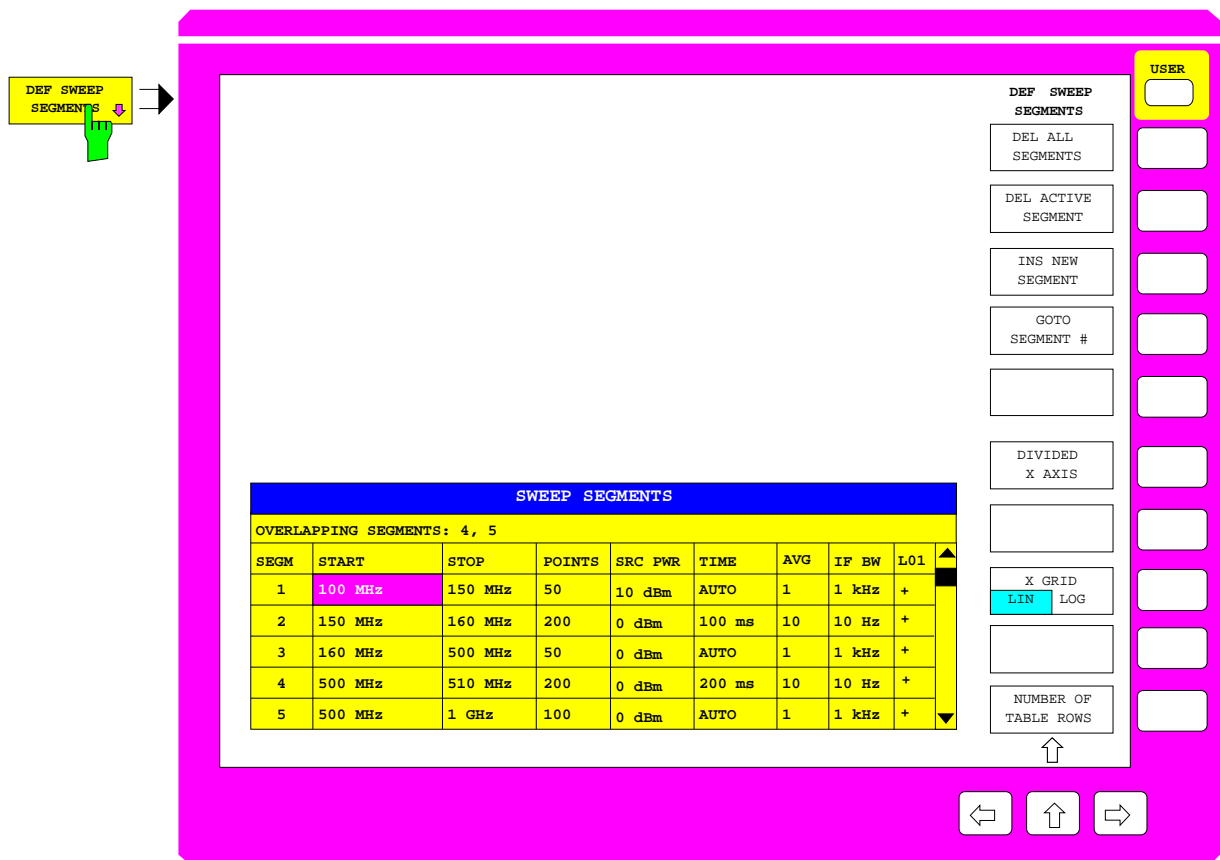


Fig. 2-33 Editing the segment list

When *DEF SEGMENT LIST* is called, the *SWEEP SEGMENTS* table is displayed which gives an overview of the current definition of the segments in the sweep range.

The table contains the segment number plus 8 columns which can be edited:

SEGM – current number of the segment

The parameters entered in the following columns refer to the segment currently active.

START – start frequency of segment

STOP – stop frequency of segment

The *START* and *STOP* columns contain the limits of a segment. In contrast to the equivalent keys, they may both be set to the same value. In this case, the number of points in the segment (see column *POINTS* below) is reduced to one

If $START > STOP$ is entered, the system sets $START = STOP$ and only one measuring point in the current segment is used.

In Cartesian diagrams (except with active segmented sweep and equidistant division of the axis *DIVIDED X AXIS*), the entry of segment limits is graphically supported. All segment limits currently defined are displayed as solid vertical lines labeled with the corresponding segment number. In addition, an arrow pointing towards the interior of the segment indicates whether the line marks the start or the stop frequency of the segment.

POINTS – Number of points in the active segment

The *POINTS* column contains the total number of points analogous to the entry via the *SWEEP - NUMBER OF POINTS* softkey. The number of points must be at least 1. The total number of points is limited and depends on the number of display channels.

SRC PWR – Power of the internal source in dBm.

The *SRC PWR* column contains the power of the internal source analogous to the entry via the *SOURCE - POWER* softkey.

If the currently active segment overlaps one or more other ones, a message is displayed and the power value can be applied to all overlapping segments.

If power calibration is active (*CAL CAL-POWER UNCAL* softkey deactivated), the *SRC PWR* column cannot be edited. It contains the entry *POWER CAL*.

TIME – sweep time for the segment

The *TIME* column contains the sweep time analogous to the entry via the *SOURCE - EDIT SWEEP TIME* softkey. When the column is edited, a further table is superimposed:

| |
|--------|
| TIME |
| AUTO |
| 200 ms |

AUTO Selecting the *AUTO* field sets the sweep time automatically to the minimum value.

200 ms A sweep time can be edited manually in the numeric field.

The *TIME* field can be edited only if the current segment does not overlap any other segment.

AVG – number of measured values used for averaging in the segment

The *AVG* field contains the averaging factor analogous to the entry via the *AVG - AVG FACTOR* softkey. If the currently valid segment overlaps one or more other segments, the entered value is applied to all overlapping segments after acknowledgement.

IF BW – Bandwidth of the IF input filter in the segment

The *IF BW* field opens a further table which allows for selection of the bandwidth of the IF input filter.

| |
|--------------|
| IF BW |
| 1 Hz |
| 3 Hz |
| 10 Hz |
| 30 Hz |
| 100 Hz |
| 300 Hz |
| 1 kHz |
| 3 kHz |
| 10 kHz |
| FULL |

This selection table is analogous to the *AVG - IF BANDWIDTH* menu. The other setting parameters selected by the *AVG* key remain effective. Refer to the *AVG - IF BANDWIDTH* menu for automatic selection of a smaller bandwidth with low frequencies.

If the current segment overlaps one or more other segments, the entered value is applied to all overlapping segments after acknowledgement.

LO1 – Frequency of first local oscillator referred to the measurement frequency

The column *LO1* is used to select whether the frequency of the first local oscillator (LO of the first mixer stage in the receiver) is set to a value which is higher (+) or lower (-) than the measurement frequency. For filters with very steep edges, unwanted mixer products that occur in a receiver mixer of the network analyzer may cause artifacts on the trace. In the default setting, the first LO is above the measurement frequency. In a transmission measurement of a DUT causing strong reflections (e.g. of a bandpass in its stop band), a mixer product with frequency $1^{\text{st}} \text{ LO} + 1^{\text{st}} \text{ IF}$ which is about 42 MHz above the measurement frequency, is generated in the receiver mixer of the reflected wave. Due to the finite backward isolation of the receiver, a small part of this spurious signal propagates via the port to the DUT. If the DUT is a bandpass, the spurious signal is transmitted for measurement frequencies which are larger than the lower limit of the pass band minus 42 MHz. In the receiver mixer for the transmission, it is converted to the 1^{st} IF just like the measurement frequency. This causes a virtual flattening of the filter edge or, in case of a narrow bandpass, a virtual pass band at the center frequency of the bandpass minus 42 MHz.

This effect can be eliminated by dividing the sweep range at the center frequency of the band pass into two segments and setting LO to "-" in the low-frequency segment. In this segment, the 1^{st} LO is below the measurement frequency and the spurious signal at measurement frequency minus 42 MHz does not distort the filter edge.

The LO1 field can not be set to "-" if the start frequency of the segment is below 50 MHz.



The *DEL ALL SEGMENTS* softkey deletes all segments of the list. Prior to deletion the user is requested to acknowledge.

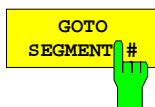


The *DEL ACTIVE SEGMENT* softkey deletes the active segment. The active segment of the list is the one where the cursor is positioned.



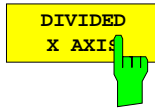
The *INS NEW SEGMENT* softkey inserts a new segment subsequent to the active segment identified by the cursor location, if the maximum number of 40 segments is not exceeded.

The active segment of the list is the one where the cursor is positioned.



If a segment number is entered via the *GOTO SEGMENT #* softkey, the corresponding segment is set active. The default setting is the following segment – if the end of the list is reached, the first segment.

The cursor of the segment list is shifted vertically to the corresponding line. The column position of the cursor is not changed.



The *DIVIDED X AXIS* softkey causes the x-axis of Cartesian diagrams to be divided into as many sections of the same width as there are segments defined in the list.

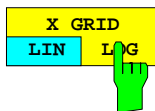
The x-axis is scaled linearly or logarithmically in all sections according to the setting via the *X GRID LIN LOG* softkey. This display mode allows to expand narrow segments of interest such as filter skirts whereas uninteresting domains can be masked out.

DIVIDED X AXIS requires:

- Cartesian diagrams,
- a maximum number of three segments,
- non-overlapping segment limits and
- a minimum number of two points per segment.

If the limits of two adjacent segments coincide, the measurement for the common stimulus value is performed twice.

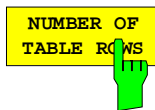
If *DIVIDED X AXIS* is active for a segmented sweep and the segment parameters are changed such that the equidistant division of the axis becomes incompatible, a system message field pops up where either *DIVIDED X AXIS* can be switched off or the parameter change can be cancelled. If the same situation occurs while the segmented sweep is switched off, however, *DIVIDED X AXIS* is disabled.



The *X GRID LIN/LOG* softkey toggles between a linear and a logarithmic grid.

The selected grid applies for all segments. If the complete segment list comprises less than two octaves, the logarithmic grid can not be selected and *X GRID LIN/LOG* is disabled.

If *X GRID LOG* is active for a segmented sweep and the segment list is reduced to less than 2 octaves, a system message field pops up where either *X GRID LIN* can be selected or the frequency change can be cancelled. If the same situation occurs while the segmented sweep is switched off, however, *X GRID LIN/LOG* is disabled.



The *NUMBER OF TABLE ROWS* softkey activates the entry of the maximum number of segments indicated in the table.

A small value prevents the diagram to be largely covered by the table. This setting is recommended, especially when segment limits are entered via the graphic cursor.

In the default setting, *NUMBER OF TABLE ROWS* is equal to the current total number of segments and will be automatically adjusted when a segment is added or removed. *NUMBER OF TABLE ROWS* is not changed, however, if the number of displayed segments is defined to be smaller than the total number of segments, or if more than 27 segments are defined.

2.10.1.3 Defining the Number of Points

SWEEP SWEEP – NUMBER OF POINTS submenu:

| SWEEP | NUMBER OF POINTS |
|------------------------|------------------|
| SINGLE POINT | ARBITRARY |
| LIN SWEEP | |
| LOG SWEEP | 51 |
| SEG SWEEP | 101 |
| DEF SWEEP SEGMENTS ↓ | 201 |
| NUMBER OF POINTS ↓ | 401 |
| TRIGGER ↓ | 801 |
| SWEEP TIME AUTO MAN | 1601 |
| EDIT SWEEP TIME | STEP SIZE |
| COUPLED CHANNELS | POINTS/DEC |

The *NUMBER OF POINTS* softkey opens a submenu defining the number of sweep points.

This is possible for linear (*LIN SWEEP*) or logarithmic (*LOG SWEEP*) grids but not when a segment list (*SEG SWEEP*) is used.

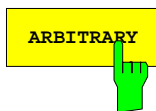
- Any number between two and the maximum number can be entered using the *ARBITRARY* softkey.
- A few numbers are predefined via softkey (51...1601).
- A fixed step size can be specified for linear sweeps (*STEP SIZE*).
- A number of points per decade can be specified for logarithmic sweeps (*POINTS/DEC*).

The maximum number is 2001 for one display channel, 1001 for two channels and 501 for four channels.

Switching on further display channels may cause the number of points to be larger than the maximum number allowed per channel. In this case, the number of points is automatically reduced to the respective maximum number for each channel and a message is displayed.

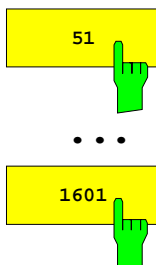
The maximum number of points for group delay measurements with frequency aperture (*FORMAT - GROUP DELAY* and *FORMAT - FREQUENCY APERTURE* activated) is one half of the points which are possible for other formattings.

If the sweep range is so narrow that the selected number of points leads to a step size below the hardware-dependent lowest resolution, the number of points is reduced such that the step size corresponds to the minimum resolution.

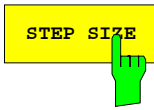


The *ARBITRARY* softkey opens the entry of the number of points. The default value is 401.

The number of points can be predefined arbitrarily between two and the maximum number. The maximum number depends on the number of display channels (see below).



The softkeys labeled 51, 101, 201, 401, 801 and 1601 set the corresponding number of points directly. 401 points are set as default.

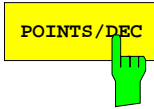


The *STEP SIZE* softkey activates the entry of the step size of the sweep variables between two points.

This softkey is enabled only if *LIN SWEEP* is active.

If the current width of the sweep range divided by the entered step size is no integer ratio, the distance between the last and the last but one point is set smaller than the required step size. If it is less than 1% of the *STEP SIZE* value, the last but one point is cancelled.

The step size (*STEP SIZE*) can not exceed the width of the sweep range.



The *POINTS/DEC* softkey activates the entry of the number of points in one sweep decade.

This softkey is enabled only if *LOG SWEEP* is active.

2.10.1.4 Setting the Trigger Mode

The *DEF TRIGGER* softkey calls the menu for setting the trigger mode.

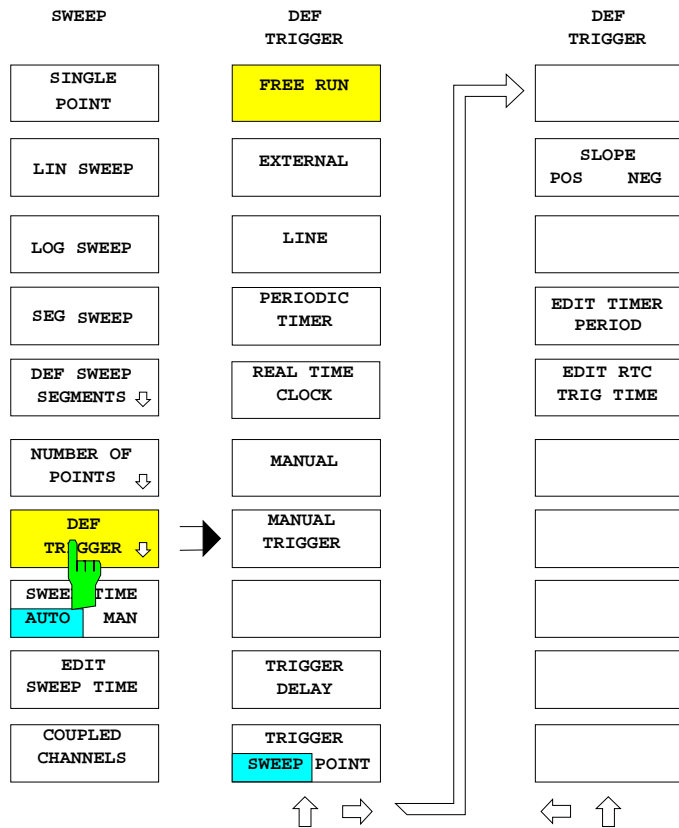
This provides the following options:

- Free-running measurement at utmost speed (*FREE RUN*).
- Triggering by
 - an external clock signal with reaction to the positive or negative edge (*EXTERNAL, SLOPE POS/NEG*),
 - the ac voltage (*LINE*),
 - the internal clock generator with settable period (*PERIODIC TIMER, EDIT TIMER PERIOD*),
 - the system time (*REAL TIME CLOCK, EDIT RTC TRIG TIME*),
 - a keystroke (*MANUAL, MANUAL TRIGGER*).
- It is possible to delay the triggered measurement by a user-defined period of time (*TRIGGER DELAY*).
- The triggered measurement may be either a single point measurement or a complete sweep (*TRIGGER SWEEP/POINT*).

In the *TIME SWEEP* mode and with manual setting of the sweep time (*SOURCE - SWEEP TIME AUTO MAN* in *MAN* position), the measurement of one single sweep point can not be triggered.

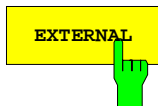
If a trigger event occurs before the previously triggered measurement has been terminated, a message is displayed.

SWEEP SWEEP – DEF TRIGGER submenu:



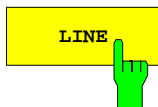
The *FREE RUN* softkey activates the free-running measuring mode. This is the default setting.

In the free-running mode, a new measurement is started immediately upon termination of the previous measurement. This means that the measurement does not adhere to a fixed time reference but is performed as fast as possible.

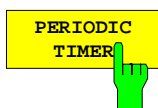


The *EXTERNAL* softkey switches on the external triggering. The enhancement label TRG EXT is displayed.

In the external trigger mode, a measurement is triggered by the rising or falling slope of a TTL signal at the EXT TRIGGER input on the rear panel depending on the position of the toggle switch *SLOPE POS/NEG*.

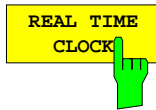


The *LINE* softkey activates triggering of the measurement by zero-axis crossing of the ac voltage. The enhancement label TRG LIN is displayed.



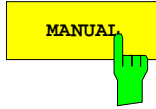
The *PERIODIC TIMER* softkey selects an internal clock generator as trigger source. The enhancement label TRG TIM is displayed.

The period of the internal trigger source can be defined via the *EDIT TIMER PERIOD* softkey (see below).



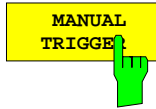
The *REAL TIME CLOCK* softkey defines the real-time clock as trigger signal. The enhancement label TRG RTC is displayed.

If *REAL TIME CLOCK* is activated, the trigger point can be entered via the *EDIT RTC TRIG TIME* softkey (see below).

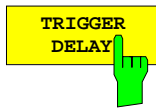


The *MANUAL* softkey switches on manual triggering. The enhancement label TRG MAN is displayed.

In the manual trigger mode, a measurement is triggered by activating the *MANUAL TRIGGER* softkey.



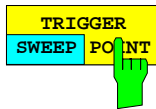
The *MANUAL TRIGGER* softkey starts the measurement if the *MANUAL* trigger mode is active



The *TRIGGER DELAY* softkey activates the entry of a delay time between the trigger event and the start of the measurement. The default delay is 0 s (immediate measurement).

If several raw values must be measured at one point – as, e.g., for forward and reverse measurement, for measurement of the group delay with frequency aperture or for the determination of compression or intercept points – then the delay time is inserted prior to each single measurement.

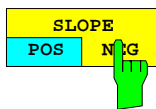
If *PERIODIC TIMER* is selected as a trigger source, no trigger delay time can be inserted.



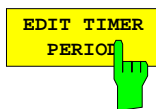
The *TRIGGER SWEEP/POINT* softkey selects whether a complete sweep is started by a trigger event (*SWEEP*). The *POINT* position switches over to the subsequent point.

If *SWEEP - SINGLE POINT* is active, then *SWEEP* and *POINT* have the same function. *SWEEP* is the default setting.

In the *TIME SWEEP* mode and with manual setting of the sweep time (*SOURCE - SWEEP TIME AUTO MAN* in *MAN* position) the measurement of one single sweep point can not be triggered.



The *SLOPE POS/NEG* softkey defines whether the rising (*POS*) or falling (*NEG*) edge of a TTL signal at the EXT TRIGGER input initiates triggering in the *EXTERNAL* trigger mode.



The *EDIT TIMER PERIOD* softkey activates the entry of the period of the internal clock generator, which is used in the trigger mode *PERIODIC TIMER*.

| TIMER PERIOD | | |
|--------------|-------|-----|
| 0 h | 0 min | 1 s |

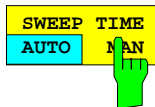


The *EDIT RTC TRIG TIME* softkey activates the entry of a trigger point which is related to the internal real time clock.

| RTC TRIGGER TIME | | |
|------------------------|--------|-----|
| 15 h | 30 min | 0 s |
| SYSTEM CLOCK: 12:23:56 | | |

2.10.1.5 Automatic or Manual Setting of the Sweep Time

SWEEP SWEEP menu:



The *SWEEP TIME AUTO/MAN* softkey defines the setting of the sweep time in the frequency or power sweep modes (*MODE - SWEEP TYPE - FREQUENCY SWEEP* and *POWER SWEEP*). The default setting is *AUTO*.

AUTO In the automatic mode (*AUTO*), the shortest possible sweep time is selected for each point.

MAN Manual setting of the sweep time is done via the *EDIT SWEEP TIME* softkey.

With manual setting of the sweep time (*MAN*), the sweep is not performed according to a fixed time reference but the difference between the manually set and the shortest possible sweep time is distributed evenly on the points. This constant waiting period between setting of the signal source and the start of the measurement is provided to the DUT for settling at each sweep point.

The *SWEEP TIME AUTO/MAN* softkey is disabled in the time sweep mode (*SYSTEM MODE - SWEEP TYPE - TIME SWEEP* active), if a nonlinear measurement is switched on (*SYSTEM MODE - COMPRESS SOI TOI - COMPRESS POINT / SOI / TOI* active), or if every measurement point is triggered (*SWEEP SWEEP - DEF TRIGGER - TRIGGER POINT* active).



The *EDIT SWEEP TIME* softkey activates the manual entry of the sweep time.

This is possible in the operating modes frequency sweep and power sweep (*SYSTEM MODE - SWEEP TYPE - FREQUENCY* and *POWER SWEEP*).

The actual sweep time may deviate slightly from the entered time. If the receive frequency is below 100 kHz in a part of the sweep, the actual sweep time may be considerably longer than the rated value since additional internal waiting times are required.

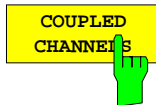
If the softkey *EDIT SWEEP TIME* is selected while *SWEEP TIME AUTO/MAN* assumes the *AUTO* position, the softkey switches over to *MAN*.

The *EDIT SWEEP TIME* softkey is disabled in the time sweep mode (*SYSTEM MODE - SWEEP TYPE - TIME SWEEP* active), if a nonlinear measurement is switched on (*SYSTEM MODE - COMPRESS SOI TOI - COMPRESS POINT / SOI / TOI* active), or if every measurement point is triggered (*SWEEP SWEEP - DEF TRIGGER - TRIGGER POINT* active).

2.10.1.6 Coupling of Display Channels

The NWA provides four independent display channels selected via the *CH1*, ... , *CH4* keys in the *CHANNEL* group. The setting parameters for these channels can be subdivided into three categories:

- **Global** parameters are always identical for all of the 4 display channels. These are the IEC-bus addresses, attenuation setting, triggering and the settings selected via the *RESPONSE DISPLAY* key.
- **Channel-specific** setting parameters can be set separately for all of the 4 channels. This group comprises the parameters in the *RESPONSE* key field, except for the functions selected via the *RESPONSE DISPLAY* key.
- **Coupled** setting parameters are either global or channel-specific. These are the following:
 - Mode settings in the *SYSTEM MODE - FREQUENCY CONVERTS*, *SYSTEM MODE - COMPRESS SOI TOI* and *SYSTEM MODE - SWEEP TYPE* menus,
 - Functions of the *STIMULUS* key group (*START*, *STOP*, *CENTER*, *SPAN* hard keys),
 - Functions of the *SWEEP* key field (*SWEEP*, *RESTART*, *SOURCE* and *AVG* keys) except for the attenuations and the settings made in the *DEF TRIGGER* menu,
 - System error and level correction data and settings.



The *COUPLED CHANNELS* softkey sets the coupled parameters of all 4 display channels according to the parameters of the currently selected channel. If *COUPLED CHANNELS* is switched off, the parameters can be modified for each channel individually.

If the channels are coupled, the measuring data are obtained for all of the four channels simultaneously. With de-coupled channels, a separate sweep is performed for each channel.

When *COUPLED CHANNELS* is switched on, the values of the coupled parameters in the inactive display channels are deleted. Especially for calibration data, this side effect can be unwelcome. Therefore, a query is displayed if switching on the channel coupling could cause the calibration data to be lost.

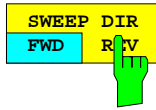
Switching off *COUPLED CHANNELS* alone does not change the values of the parameters.

If several channels are displayed in conjunction with S-parameters and mere wave sizes or wave ratios, the channels can not be coupled. Coupling is impossible also, if the group delay with frequency aperture is measured in one channel (*FORMAT - GROUP DELAY* and *FORMAT - FREQUENCY APERTURE* active).

If the activated channel coupling is rendered illegal by subsequent entry, it is switched off and a message is displayed.

2.10.1.7 Miscellaneous Settings

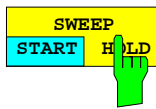
SWEEP SWEEP menu:



The *SWEEP DIR FWD/REV* softkey reverses the sweep direction. The forward direction is the default setting (*FWD* position).

Reversing the sweep direction is particularly suitable in the low-frequency range. Since devices under test may have very long settling times in the AF range, the low-frequency phase shift caused by the start of a new forward sweep may lead to considerable measurement errors. This problem can be avoided by reversing the sweep direction, since the settling time in the high-frequency domain is considerably lower and the DUT has settled already when reaching lower frequencies - provided that phase continuity of the trigger signal is ensured.

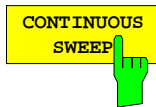
The *SWEEP DIR FWD/REV* softkey can not be activated in the *TIME SWEEP* mode.



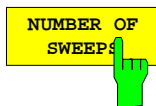
The *SWEEP START/HOLD* softkey disables (*HOLD*) or enables (*START*) the sweep. The default setting is *START*.

After switching over to *HOLD*, the measurement of the currently active point is terminated before the instrument assumes the *HOLD* state. The latter is indicated by the enhancement label HLD. After switching back to *START*, the measurement is continued starting at the subsequent point. Pressing the *CONTINUOUS SWEEP*, *NUMBER OF SWEEPS*, *SINGLE SWEEP* softkeys or the *RESTART* key resets the toggle switch to *CONT*, too.

SWEEP START/HOLD is effective for single point measurements (*SWEEP - SINGLE POINT* active), too. If trigger events are ignored in the *HOLD* state, no corresponding message is displayed.



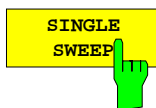
The *CONTINUOUS SWEEP* softkey switches to the continuous measuring mode allowing an infinite number of sweeps or single point measurements. This is the default setting.



The *NUMBER OF SWEEPS* softkey activates the entry of a limited number of sweeps.

When the specified number of sweeps has been performed, the measurement is terminated. The specified number of sweeps can be restarted by pressing one of the softkeys *NUMBER OF SWEEPS* or *SWEEP START/HOLD*.

For single-point measurement (*SWEEP - SINGLE POINT* active) the number of measurements at this point can be specified using the *NUMBER OF SWEEPS* softkey.

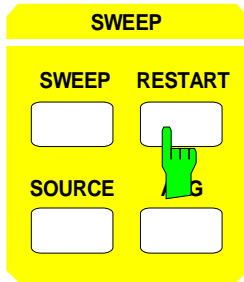


The *SINGLE SWEEP* softkey limits the number of sweeps to one.

This is equivalent to the entry *NUMBER OF SWEEPS = 1*. After one sweep, the measurement is terminated. A further sweep can be restarted using one of the softkeys *SINGLE SWEEP* or *SWEEP START/HOLD*.

With single point measurement, (*SWEEP - SINGLE POINT* active) only one measurement is performed.

2.10.2 Starting a New Sweep – *RESTART* Key



The *RESTART* key aborts the currently active sweep and starts a new one at the start value.

At the same time, the averaging procedure is initialized, i.e., the current average at a point is replaced by the first new measured value (see *AVG - AVERAGE RESTART*). This is suitable, e.g., if the DUT has been modified during long sweep times or after averaging over many points.

Pressing the *RESTART* key when the sweep is interrupted resets the *SWEEP START/HOLD* softkey to *START*

2.10.3 Setting Fixed Sweep Parameters – SOURCE Key

The *SOURCE* key opens a menu setting the fixed parameters of the sweep.

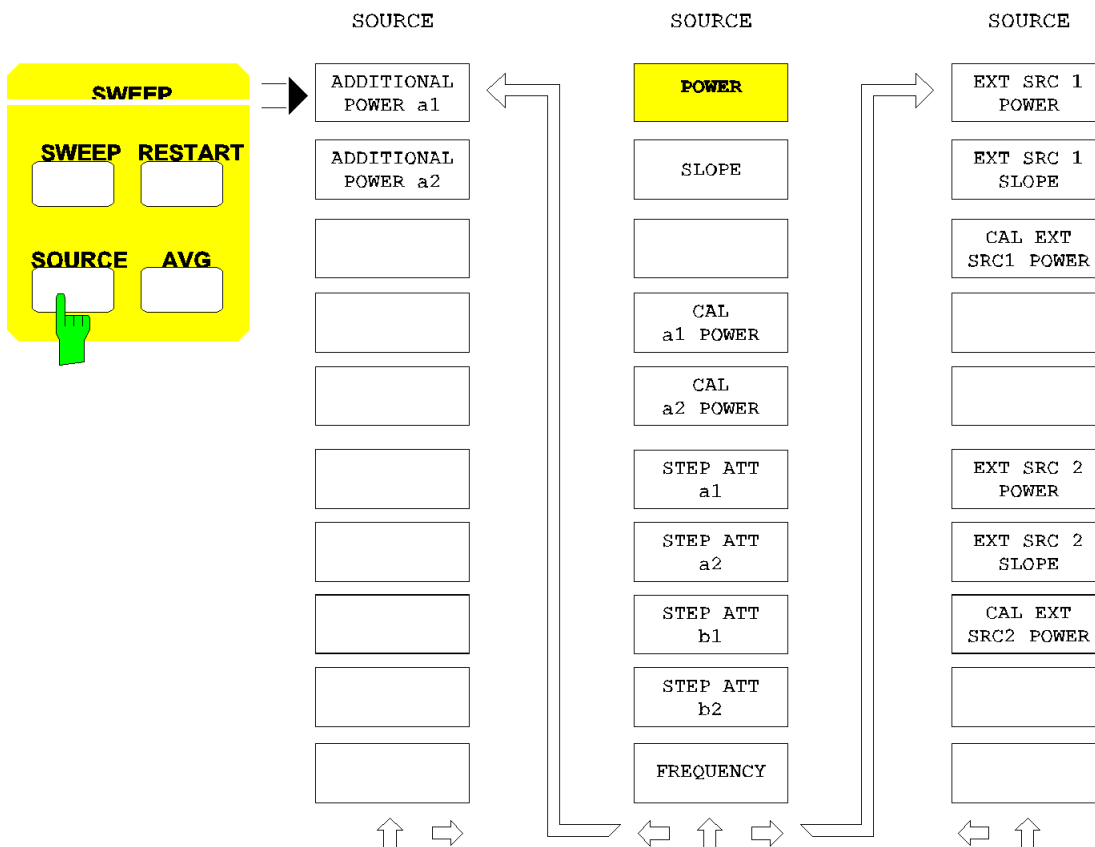
- The main menu and (on ZVK and ZVM) the left supplementary menu contain internal settings.
- The right supplementary menu refers to optionally fitted external sources. Calling the supplementary menu therefore causes display of the *EXT SOURCES CONFIG* menu (see *SYSTEM MODE - DEF MIXER MEAS*).

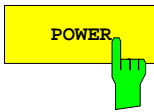
The following setting values may be entered:

- Power (POWER) of the internal signal source.
- In the frequency sweep mode, a slope factor which multiplies the frequency (SLOPE). This allows for compensation of any frequency-proportional loss, e.g., that of cables.
- Level of the output signals a1 and a2 provided that a power correction of these signal is active (*CAL a1 POWER*, *CAL a2 POWER*).
- Attenuation values for various attenuators (STEP ATT) if the corresponding options are fixed.
- in the frequency or power sweep mode, a value for the CW-frequency (FREQUENCY),
- the levels and slope factors for the two external sources (*EXT SRC 1 POWER*, ... , *EXT SRC 2 SLOPE*).
- Level of the external signal sources 1 and 2 provided that a power correction of these sources is active (*CAL EXT SRC1 POWER*, *CAL EXT SRC2 POWER*).
- Only with ZVK and ZVM: increase of generator power to the detriment of test port matching (*ADDITIONAL POWER a1*, *ADDITIONAL POWER a2*).

Note: Attenuation values of the generator step attenuators different from 0 dB may reduce the dynamic range. If any changes are made to the generator power or the attenuation values, the system error correction data may not be valid any more. The CAL or CAI enhancement label, therefore, changes to CA?. An exception is formed by ZVK and ZVM, see description of STEP ATT a1 softkey.

SWEEP SOURCE menu:





The *POWER* softkey allows to vary the power of the internal signal source electronically.

The following applies to models ZVRx and ZVCx:

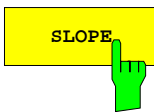
- In the internal operating mode (*SYSTEM MODE - EXTERNAL - EXTERNAL* softkey disabled) without option ZVR-B10, the indicated level refers to PORT 1 and PORT 2.
- If option ZVR-B10 ("High Power") is fitted, the *POWER* setting in the internal mode refers to test port PORT 1. The level at PORT 2 is lower by a constant value depending on the instrument type. Both levels are shown in the input field.
- In the external mode (*EXTERNAL* activated), the level is valid for the OUTPUT socket.

For ZVK and ZVM, setting value *POWER* is always valid for PORT 1 and PORT 2.

The generator level serves as an entry value; the attenuation of eventually fitted generator attenuators is assumed to be set to zero. The actual levels applied to the currently active sockets, taking into account the attenuations due to attenuators, are also displayed in the entry field.

If a segment list is active (*SWEEP - SEG SWEEP*), the power information on the individual segments of the sweep list is directly taken from the list. *POWER* and *SLOPE* are then disabled.

The *POWER* softkey is operative only in the frequency or time sweep mode on condition that no generator power correction is active for wave a_1 or a_2 .



The *SLOPE* softkey activates the entry of a factor varying the slope of a frequency sweep in units of dB/GHz. The default value is 0 dB/GHz (no extra slope).

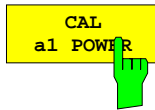
Slope factors can be used in the operating mode frequency sweep (*SYSTEM MODE - SWEEP - FREQUENCY SWEEP*) to compensate for frequency-proportional losses in the test setup, e.g., cable losses. The entered factor is multiplied to the difference between current frequency and start frequency, the result is then added to the constant power (*POWER*).

Example: *If the sweep range varies between 2 GHz and 4 GHz and POWER is set to -10 dBm, the entry of SLOPE = 2 dB/GHz causes the level at the OUTPUT socket in the linear sweep range to increase linearly from -10 dBm to -6 dBm.*

If the specified *SLOPE* value causes the maximum or minimum allowed level to be reached at a particular frequency inside the sweep range, the level is held constant beyond this frequency.

If the *POWER* softkey is activated while a level correction is active, the latter is switched off (*CAL CAL - POWER UNCAL* is switched on) and a warning is displayed.

The *SLOPE* softkey is operative only in the frequency or time sweep mode on condition that no generator power correction is active for a_1 or a_2 .

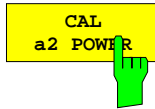


The *CAL a1 POWER* softkey sets the power of wave a_1 provided the generator power correction for wave a_1 is active.

The input value is the power at the reference plane of calibration. If the attenuation value (*STEP ATT a1*) of the generator step attenuators is changed, the input value is adapted automatically.

CAL a1 POWER is operative only in the frequency or time sweep mode on condition that the generator power correction is active for wave a_1 .

Note: *In the CAL a1 POWER entry field, the uncalibrated nominal power of port 2 is displayed in addition.*



The *CAL a2 POWER* softkey sets the power of wave a_2 provided the generator power correction for wave a_2 is active.

For the function of this softkey, refer to *CAL a1 POWER*.



(only ZVR, ZVRL, ZVC, ZVK, ZVM and ZVRE/ZVCE with option ZVR-B10)

The *STEP ATT a1* softkey activates the entry of an attenuation value for the attenuator connected to the signal path of the wave a_1 propagating towards the DUT. This requires the option ZVR-B21 or ZVM-B21, "Generator Step Attenuator PORT 1" to be fitted.

An attenuation of the incident wave is suitable, e.g. for DUTs which are sensitive to high levels or those causing high attenuation. The attenuation value can be varied between 0 dB and 70 dB in steps of 10 dB, the default value is 0 dB.

The output powers applied to the currently active sockets, taking into account the attenuation values due to attenuators, are also indicated in the entry field, provided that no generator power calibration is active.

If, with system error correction switched on, the attenuation value of a generator step attenuator is changed, the nominal change of attenuation is taken into account, which may slightly vary from the actual change. The CAL enhancement label changes to CA?. An exception is ZVK and ZVM with *FULL ONE PORT* or 7-term calibration (*TOM, TRM, TRL, TNA*). The ZVK/ZVM test set is designed such that the system error correction data remain valid without any restrictions for the said calibration methods if the attenuation of a generator step attenuator is changed.

Analogously, the nominal change of *STEP ATT a1* is taken into account both in the generator and the receiver power correction of wave a_1 . The value set for *CAL a1 POWER* is adapted automatically, and the PC enhancement label changes to PCO.

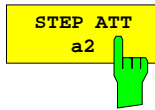
Note: *In the frequency and time sweep modes, the STEP ATT a1 entry field indicates the generator powers at the test ports with the current attenuation of the generator step attenuators taken into account. If power calibration is active for a port, one of the generator power values refers to the reference plane of calibration, the other value is the uncalibrated nominal power of the other port and is marked UNCAL.*



(only ZVRE, ZVCE without ZVR-B10)

The *STEP ATT a1 AND a2* softkey activates the entry of an attenuation value for an attenuator located in the signal path of the waves a_1 and a_2 propagating towards the DUT prior to the signal path changeover switch. This requires the option ZVR-B21, "Step Attenuator for Generator Port 1" to be fitted.

Refer to the description of the *STEP ATT a1* softkey for the function of this softkey.



(only ZVR, ZVC, ZVK, ZVM and ZVRE/ZVCE with option ZVR-B10)

The *STEP ATT a1* softkey activates the entry of an attenuation value for the attenuator connected to the signal path of the wave a2 propagating towards the DUT. This requires the option ZVR-B22 or ZVM-B22, "Step Attenuator for Generator Port 2" to be fitted.

This softkey can be used in the internal operating mode only (*SYSTEM MODE - EXTERNAL* switched off).

Refer to the description of the softkey *STEP ATT a1* for the function of this softkey.



The *STEP ATT b1* softkey activates the entry of an attenuation value for the attenuator connected to the signal path of the wave b1. This requires the option ZVR-B23 or ZVM-B23, "Receiver Step Attenuator PORT 1" to be fitted.

The attenuation value can be varied between 0 dB and 70 dB in steps of 10 dB, the preset value is 0 dB (. An attenuation of the wave b1 is suitable, e. g., to reduce the output level of a power amplifier to the permitted input level range of the network analyzer.

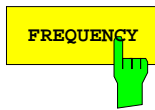
If, with system error correction switched on, the attenuation value of a receiver step attenuator is changed, the nominal change of attenuation is taken into account, which may slightly vary from the actual change. The CAL enhancement label changes to CA?.

Analogously, the nominal change of *STEP ATT b1* is taken into account in the receiver power correction of wave b₁. The PC enhancement label changes to PCO.



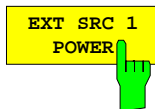
The *STEP ATT b2* softkey activates the entry of an attenuation value for the attenuator connected to the signal path of the wave b2. This requires the option ZVR-B24 or ZVM-B24, "Step Attenuator for Receiver Port 2" to be fitted. The default value is 0 dB.

Refer to the description of the softkey *STEP ATT a1* the function of this softkey.



The *FREQUENCY* softkey activates the entry of the CW frequency of the internal signal generator.

This is possible in the time sweep and power sweep modes (*SYSTEM MODE - SWEEP TYPE - TIME SWEEP* and *POWER SWEEP*). The CW frequency is displayed at the bottom left in the measuring diagram.



The *EXT SRC 1 POWER* softkey activates the entry of the constant level of the external signal source 1.

This is possible if one of the options ZVR-B4, "Frequency-converting Measurements" or ZVR-B5, "Non-linear Measurements" is fitted and an operating mode is selected which requires the external source 1 (e.g., mixer measurement). Moreover, the source must be configured as IEC or IEC+TTL in the *REMOTE* field of the *EXT SOURCES CONFIG* table and no generator level correction of this source must be switched on.

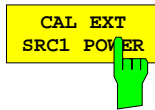
The permitted range of the level depends on the type of the signal generator used and is also indicated in the *EXT SOURCES CONFIG* table.



The *EXT SRC 1 SLOPE* softkey activates the entry of the slope for the level of the external source 1.

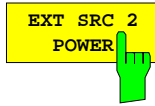
Refer to the *SLOPE* softkey concerning the function.

EXT SRC 1 SLOPE can be operated only if the generator level correction for the external source 1 is switched off.



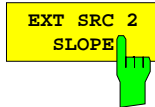
The *CAL EXT SRC1 POWER* softkey sets the level of the external signal source 1 if a level correction of this source is active.

CAL EXT SRC1 POWER can be operated only if the generator level correction for the external source 1 is switched off.



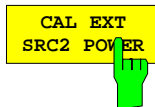
The *EXT SRC 2 POWER* softkey activates the entry of the constant level of the external source 2.

Refer to the *EXT SRC 1 POWER* softkey concerning the function.

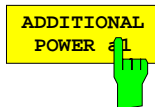


The *EXT SRC 2 SLOPE* softkey activates the entry of the slope for the level of the external source 2.

Refer to the *SLOPE* softkey concerning the function.

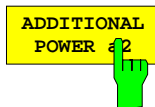


The *CAL EXT SRC2 POWER* softkey sets the level of the external signal source 2 if a level correction of this source is active.



(only ZVK/ZVM with option ZVM-B21)

The softkey *ADDITIONAL POWER a1* increases the power of the incident wave a_1 at the DUT by 3 dB. This softkey is available only if the option Generator Attenuator for ZVM PORT 1 is installed. If *ADDITIONAL POWER a1* is switched on, attenuation is reduced by 3 dB. However, this leads to poorer matching of test port PORT1.



(only ZVK/ZVM with option ZVM-B22).

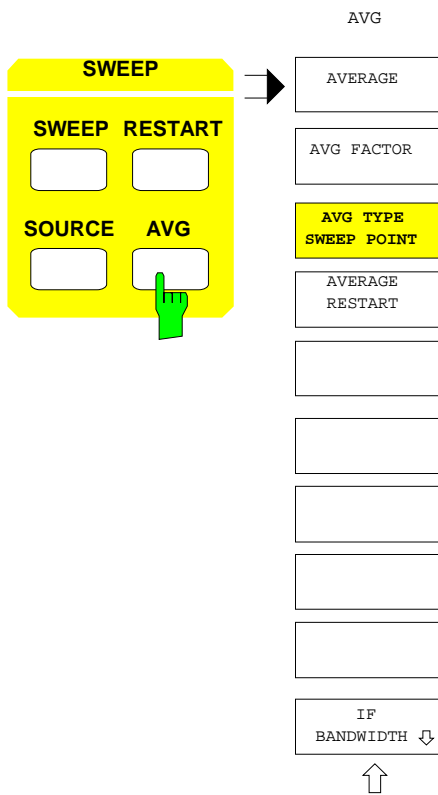
The softkey *ADDITIONAL POWER a2* increases the power of the incident wave a_2 at the DUT by 3 dB. This softkey is available only if the option Generator Attenuator for ZVM PORT 2 is installed. If *ADDITIONAL POWER a2* is switched on, attenuation is reduced by 3 dB. However, this leads to poorer matching of test port PORT2.

2.10.4 Setting the Averaging Function and the Receiver Bandwidth – AVG Key

The averaging algorithm can be interpreted as an implementation of a single-stage recursive digital filter. Similar to the IF filter, this filter reduces the noise level and thus increased the dynamic range of the measurement. Averaging is suitable for elimination of very low-frequency interferences (< 1 Hz), whereas the IF filter should be used for reliable suppression of noise signals with larger offset from the measurement frequency.

For both types of filter (IF filter and averaging), the measuring time of a point increases inversely proportional to the effective bandwidth due to the required settling time.

SWEEP AVG menu:

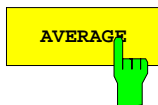


The AVG opens the menu containing all setting functions which refer to the measurement bandwidth.

Those are the following:

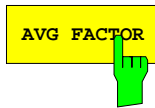
- the averaging function (*AVERAGE*),
- the entry of an averaging factor (*AVG FACTOR*),
- selection whether the averaging should take place over several sweeps or for each point individually (*AVG TYPE SWEEP POINT*),
- restart of the averaging procedure independent of other settings (*AVERAGE RESTART*),
- selection of the IF filter bandwidth.

Note: *The segment-specific parameters averaging factor and receiver bandwidth can not be set via the AVG menu if a segment list (SWEEP - SEG SWEEP activated) is used.*



The *AVERAGE* softkey switches averaging of the measured values on and off.

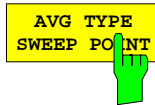
In the default state, *AVERAGE* it is switched off. If it is activated, the enhancement label *AVG* is displayed. The averaging factor (see below) is then shown in the following line. As long as the number of sweeps is smaller than the averaging factor, this number is read out instead of the averaging factor.



The *AVG FACTOR* softkey activates the entry of the averaging factor.

If the *AVG TYPE SWEEP POINT* softkey (see below) is active, the averaging factor represents the number of values measured at one point and averaged with equal weight.

In contrast, if averaging is performed over several sweeps (i. e. *AVG TYPE SWEEP POINT* is switched off), the averaging factor corresponds to the maximum number of sweeps to be averaged. From the start of the averaging procedure up to this maximum number, all sweeps are weighted equally. Afterwards, a new sweep is first weighted with the inverse of the averaging factor and, later, decreases exponentially.

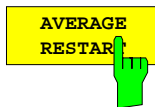


The *AVG TYPE SWEEP POINT* softkey causes the average at each point to be completed before the next point is measured. In the default state, *AVG TYPE SWEEP POINT* is switched off.

If *AVG TYPE SWEEP POINT* is switched off, the average is first formed over the sweeps. Therefore, the measurement result does not settle until several sweeps have been performed. Thus, averaging takes place over the system-error corrected measured values.

If *AVG TYPE SWEEP POINT* is switched on, the average is formed at each individual point prior to the system-error correction. Thus, a settled measurement result is obtained immediately - however, the sweep time increases.

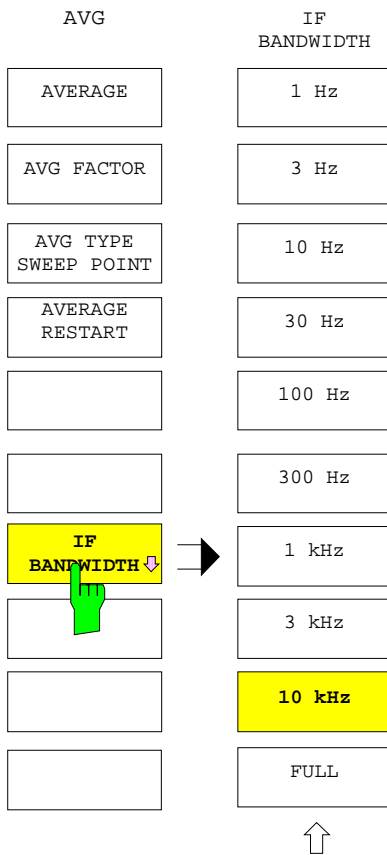
With single point measurement (*SWEEP - SINGLE POINT* or *MODE - POWER METER ON* active) the only difference between the switch positions of *AVG TYPE SWEEP POINT* is the order of system error correction and average.



The *AVERAGE RESTART* softkey causes a restart of averaging over the sweeps.

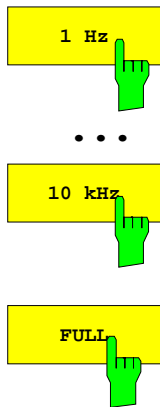
This implies that the current average of the measured quantity is replaced by the next measured value. In contrast to the *RESTART* key, *AVERAGE RESTART* does not start a new sweep.

SWEEP AVG – IF BANDWIDTH submenu:



The *IF BANDWIDTH* softkey calls the submenu for setting the bandwidth of the digital receiver filter on the intermediate frequency.

- The bandwidth can be set between *1 Hz* and *10 kHz* in 1-3-10 steps.
- In addition, the *FULL* stage with approx. 26 kHz can be chosen.



The *1 Hz ... 10 kHz* softkeys set the bandwidth of the digital receiver filter in 1-3-10 steps. The enhancement label *FIL* is displayed, the filter bandwidth is indicated in the line below.

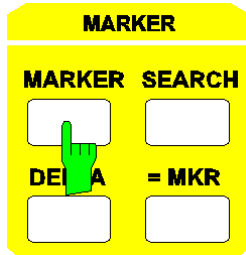
If *FULL* is active, the maximum bandwidth of approx. 26 kHz is effective.

With lower receiver frequencies, a filter bandwidth smaller than the one defined in the menu might be selected. This depends on whether the user-defined filter bandwidth exceeds a frequency-dependent maximum. The maximum bandwidths are as follows:

| Received frequency | Maximum bandwidth of the receiver filter |
|--------------------|--|
| 10 Hz ... 50 Hz | 1 Hz |
| 50 Hz ... 500 Hz | 10 Hz |
| 500 Hz ... 5 kHz | 100 Hz |
| 5 kHz ... 50 kHz | 1 kHz |
| > 50 kHz | FULL |

2.11 The Marker Functions – *MARKER* Key Group

The Marker key group comprises the *MARKER*, *SEARCH*, *DELTA*, and *= MKR* keys and provides marker functions. These are tools for specifying points in diagrams, for numerically reading out a converted and formatted measured value and for quickly setting the display range. There are up to eight markers per display channel possible.

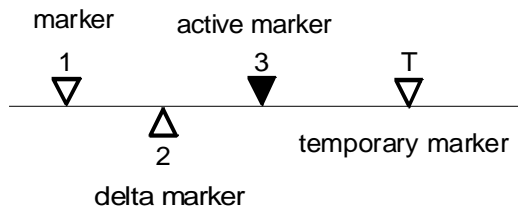


- The *MARKER* key opens a menu for switching on and off the eight markers and for selecting their format and conversion.
- The *SEARCH* key provides search functions positioning the markers to specific points of the measured curve.
- The *DELTA* key sets delta markers for determining the difference between marker values and a pre-defined reference value.
- The *= MKR* key assigns the response value of a marker to a specific parameter of the curve.

2.11.1 Main Markers – *MARKER* Key

Markers may be positioned on the trace or on a stored (memory) trace. The marker which can be currently moved by the user is defined as the active marker.

Examples:



The response value of the active marker is output at the right margin of the information line. The values of the other markers are located below the value of the active marker in the so-called marker info list, sorted according to their marker number.

Depending on the marker format in the active display channel (see section 2.11.1.2), one or two marker response values (marker values) can be displayed in a line. It is thus possible to represent, via a marker, the magnitude trace of a reflection coefficient with simultaneous readout of the real component of the impedance. The stimulus value of the corresponding marker is displayed under each line which contains the response values. Depending on the sweep mode, the stimulus value is either a frequency, time or level value. The marker info list can be switched off so that only the response values for the active marker are shown.

| | | | | |
|--|--|---------------|-------------|--|
| | | | | |
| | | Δ1: 23.345 dB | 23.76 ° | |
| | | | 456.345 MHz | |
| | | Δ2: 45.45 dB | 11.12 ° | |
| | | | 470.450 MHz | |
| | | Δ3: -12.99 dB | 1.15 ° | |
| | | | 652.198 MHz | |
| | | Δ4: -4.456 dB | 5.45 ° | |
| | | | 689.256 MHz | |
| | | | | |
| | | | | |

marker field in the information line

marker info list

Markers are always located within the sweep range. If the sweep range is changed such that the stimulus value of a marker gets below the start value (e.g., after decreasing the span), the marker is placed at the beginning of the trace. The analogue applies when the marker gets larger than the stop value.

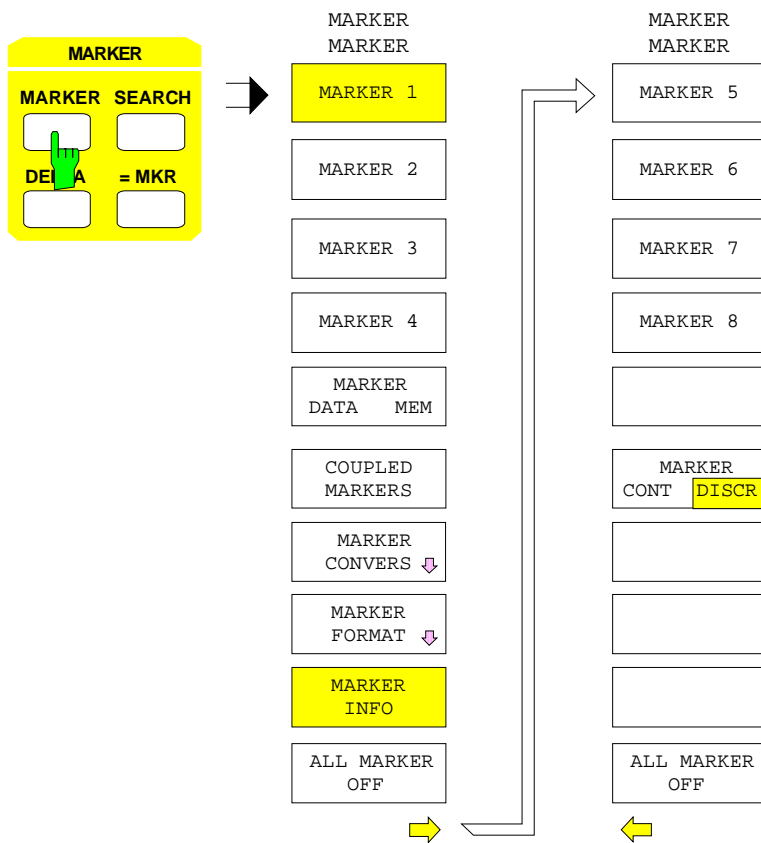
All marker characteristics (such as power-on state, position, conversion, formatting etc.) are stored individually for each of the three sweep modes *MODE - FREQUENCY SWEEP*, *TIME SWEEP* and *POWER SWEEP*, and are restored when the mode is switched. With single point measurement (*SWEEP - SINGLE POINT*), the markers are positioned in the center of the horizontal line (Cartesian diagrams) or directly on the measured point (circular diagrams) and cannot be moved.

The zoomed display of measurement diagrams has no influence on the application of markers. They can be moved between start and stop values of the sweep (and thus even outside the zoomed range of the trace). The search functions are not limited to the zoom window but evaluate the trace in the complete sweep range. Consequently, the active marker is no longer displayed in the zoomed range if the maximum is located outside the zoom window.

The *MARKER* key opens a menu that

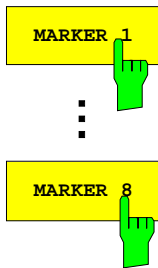
- switches on and off each of the eight markers (MARKER 1, ... , MARKER 8 in the main menu, MARKER 5, ... , MARKER 8 in the right supplementary menu),
- sets the stimulus values as well as the conversion and formatting for the markers in all display channels equal to those of the active channel (*COUPLED MARKERS*),
- sets an individual conversion for the marker values (*MARKER CONVERS*),
- sets an individual formatting for the marker values (*MARKER FORMAT*),
- switches on and off a marker info list (*MARKER INFO*),
- switches between continuous (i. e. interpolated) and discrete marker positions (*MARKER CONT/DISCR*).
- cancels all markers in the active channel (*ALL MARKER OFF*).

MARKER MARKER menu:



2.11.1.1 Switching on and Moving Markers

MARKER MARKER menu:

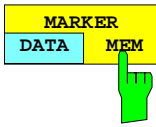


The **MARKER 1** softkey switches on the corresponding marker which becomes the active marker.

At the same time, an field for entering the stimulus value of the marker is displayed. In this way, the active marker can be moved along the trace or memory trace using the roll-key or the cursor keys.

The same applies for the markers 2 - 8.

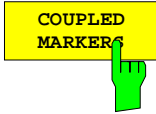
Note: *In the ARBITRARY mode, a system frequency other than the base frequency can be elected for scaling the measurement diagram. ARBITRARY SYSTEM FREQUENCIES instead of BASE FREQUENCY is displayed in the STIMULUS AXIS field of the ARBITRARY table. In this case, the entry field for the marker position indicates that the entry still refers to the base frequency and not to the scaling of the diagram.*



The *MARKER DATA MEM* softkey places the active marker either on the trace (*DATA*) or on the memory trace of the active display channel (*MEM*).

The stimulus value of the marker remains unchanged. The softkey can only be operated when two traces are displayed in the sweep range.

When *RESPONSE TRACE - SHOW MATH* is switched on, the mathematically linked trace is selected instead of the trace.



The *COUPLED MARKERS* softkey switches the marker coupling on and off.

In all channels displayed, exactly the same markers are switched on as are switched on in the active channel. Each of the stimulus values is identical in all channels, the same applies for marker conversion and formatting. Moving the active marker causes the like-numbered markers in the other channels to be moved at the same time.

Marker coupling can only be activated when the channels are coupled (*SWEEP SWEEP - COUPLED CHANNELS* on). The tracking mode for marker search (*MARKER SEARCH-TRACKING* softkey active) is switched off by *COUPLED MARKERS*.

2.11.1.2 Conversion of the Marker Value

MARKER MARKER - MARKER CONVERSION submenu:

| MARKER MARKER | MARKER CONVERSION |
|-------------------------|--------------------|
| MARKER 1 | S |
| MARKER 2 | 1 / S |
| MARKER 3 | Z |
| MARKER 4 | Z / Z ₀ |
| MARKER DATA MEM | Y |
| COUPLED MARKERS | Y / Y ₀ |
| MARKER CONVERS ↓ | |
| MARKER FORMAT ↓ | |
| MARKER INFO | |
| ALL MARKER OFF | |

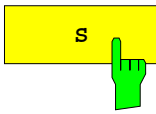
Yellow arrows point to the 'MARKER CONVERS' and 'ALL MARKER OFF' rows.

The *MARKER CONVERS* softkey opens a submenu in which the conversions of the marker values of the active display channel are set.

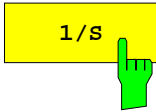
The marker value can only be converted when the measured quantity of the active channel is an S parameter.

The conversion of the marker values does not depend on the conversion of the trace. It applies to all markers of the active channel equally. If the markers are coupled (*COUPLED MARKERS*) each channel can be assigned its own individual conversion.

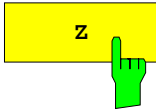
The conversion modes of the *RESPONSE MEAS - COMPLEX CONVERS* menu apply for the marker values as well. The normalization impedance Z₀ can only be defined in this menu.



The S softkey causes the marker values to be read out in a non-converted form.

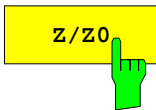


The 1/S softkey inverts the marker values.

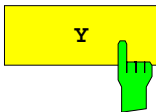


The Z softkey converts the marker values into impedances.

The value entered via the softkey *MEAS - COMPLEX CONVERTS - SET Z0* ($Y0 = 1/Z0$) is used as reference impedance.

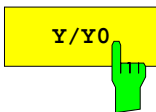


The softkey Z/Z0 converts the marker values into normalized impedances.



The Y softkey converts the marker values into admittances.

The value entered via the softkey *MEAS - COMPLEX CONVERTS - SET Z0* ($Y0 = 1/Z0$) is used as reference impedance.



The Y/Y0 softkey converts the marker values into normalized admittances.

2.11.1.3 Format of the Marker Value

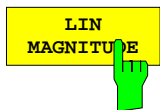
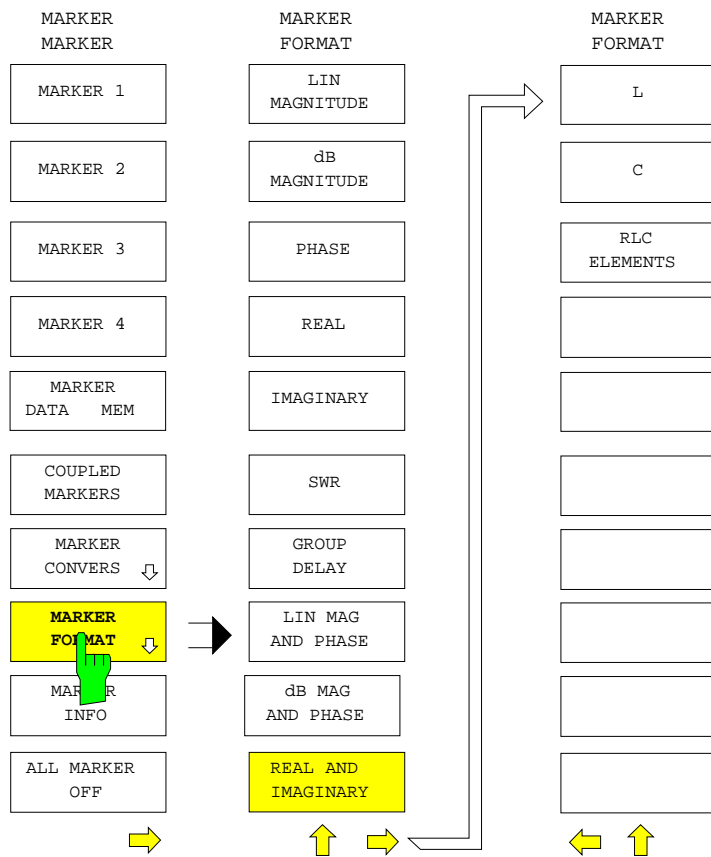
The *MARKER FORMAT* softkey calls a submenu in which the formatting of the marker values of the active display channel are set.

Similar to the conversion of markers, marker formatting is performed independent of the formatting of the trace. The selected formatting applies to all markers of the active display channel. An individual marker formatting may be selected for each channel even with coupled markers (*COUPLED MARKERS* on).

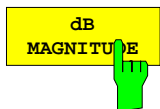
The formatting of markers is carried out similar to the formatting of trace values (see the description of the *FORMAT* key).

If single wave quantities are measured (*RESPONSE MEAS - INPUT* menu), only the marker format functions *LIN MAGNITUDE* and *dB MAGNITUDE* may be used. If the measured quantity is a quotient whose numerator or denominator is a scalar quantity (e.g. conversion gain), the standing-wave ratio function *SWR* may be additionally used.

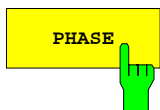
MARKER MARKER - MARKER FORMAT submenu:



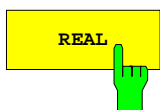
The *LIN MAGNITUDE* softkey displays the magnitude of the measured value as a marker value.



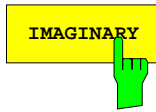
The *dB MAGNITUDE* softkey displays the magnitude of the measured value, converted into dB, as a marker value.



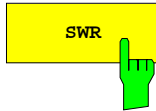
The *PHASE* softkey changes to the phase representation of the marker value.



The *REAL* softkey displays the real component of the marker value.

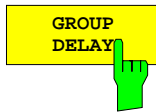


The *IMAGINARY* softkey displays the imaginary component of the marker value.



The *SWR* softkey formats the marker values as standing-wave ratios (SWR).

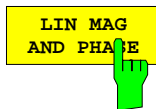
If single wave quantities are measured or if the marker conversion "impedance" or "admittance" is active, the *SWR* formatting may not be selected.



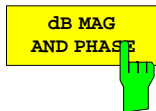
The *GROUP DELAY* softkey displays the marker value as a group delay.

The aperture width is set via the softkeys *RESPONSE FORMAT - STEP APERTURE* or *RESPONSE FORMAT - FREQUENCY APERTURE*. A frequency aperture which is independent of the grid can be used when the formatting *RESPONSE FORMAT - GROUP DELAY* with *RESPONSE FORMAT - FREQUENCY APERTURE* is active for the trace as well.

In accordance with the definition, group delay can only be measured in the "frequency sweep" mode.



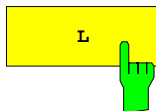
The *LIN MAG AND PHASE* softkey displays the complex magnitude and phase of the marker value.



The *dB MAG AND PHASE* softkey displays the complex magnitude and phase of the marker value, whereby the magnitude is converted to dB.

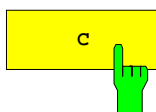


The *REAL AND IMAGINARY* softkey displays the marker value with real and imaginary components.



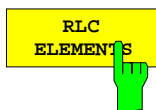
The *L* softkey converts the imaginary component of the impedance or admittance to an inductance and displays it taking into account the frequency.

The *L* softkey can only be operated when the marker conversion "Z" or "Y" is active.



The *C* softkey converts the imaginary component of the impedance or admittance to a capacitance and displays it taking into account the frequency.

The *C* softkey can only be operated when the marker conversion "Z" or "Y" is active.

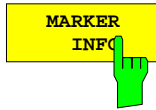


The *RLC ELEMENTS* softkey displays the real component of the impedance together with the imaginary component, which is, depending on the sign, converted to an inductance or a capacitance.

The *RLC ELEMENTS* softkey can only be operated when the marker conversion "Z" or "Y" is active.

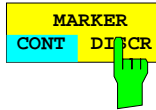
2.11.1.4 Info list and Interpolation

MARKER MARKER menu:



The *MARKER INFO* softkey switches the marker info list in the active display channel on and off.

If the list is switched off, only the response values of the active marker are shown.



The *MARKER CONT DISCR* softkey selects between continuous (interpolation between the points) and discrete marker display (marker is set to measuring points only) for the active display channel.

If the coupled mode is selected (*COUPLED MARKERS* is on), this setting applies to all four channels simultaneously.



The *ALL MARKER OFF* softkey switches off all markers and auxiliary markers of the active display channel.

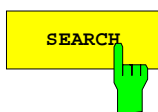
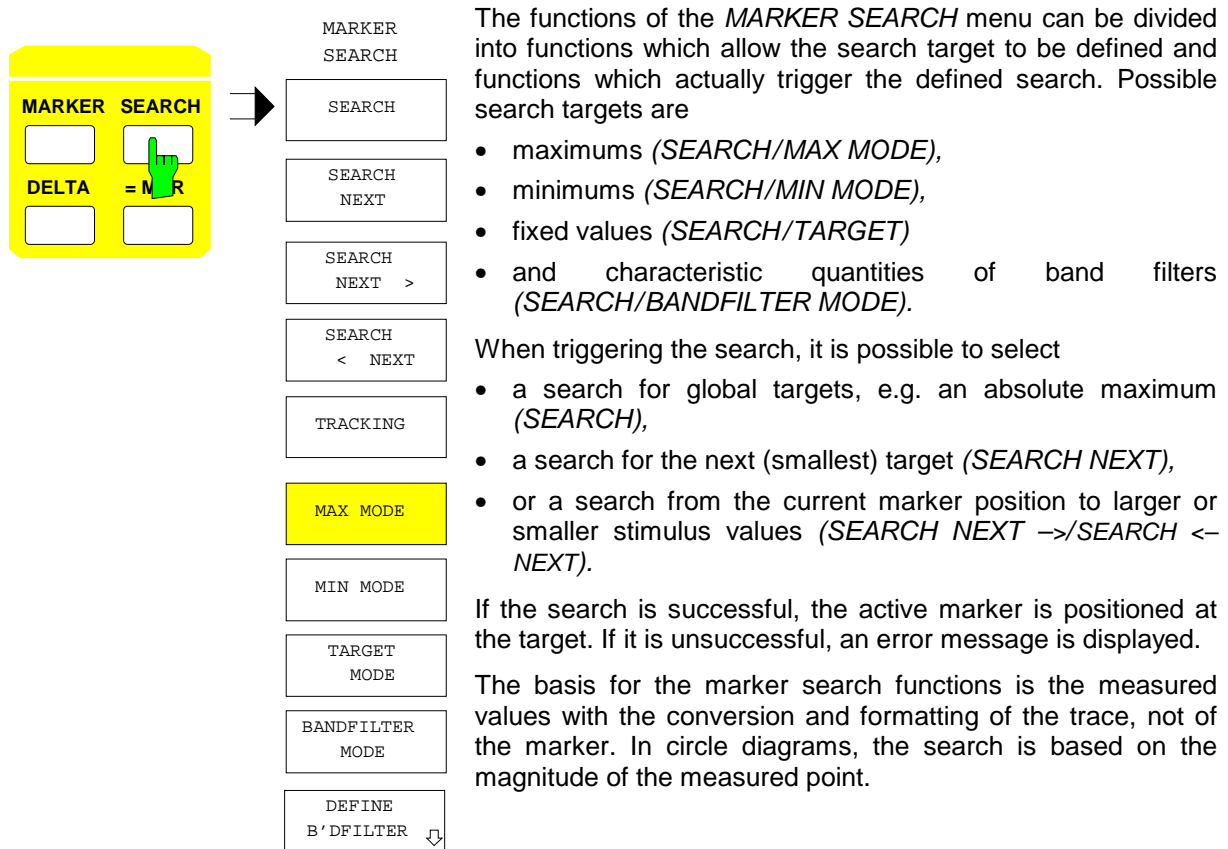
The softkey is provided once again in the right supplementary menu for the ease of operation.

2.11.2 Marker Search Functions – SEARCH Key

The *MARKER SEARCH* key opens a menu for positioning a marker to significant points on the trace (e.g. maximum, minimum etc.). The marker search functions can be triggered once manually or automatically with each sweep (*TRACKING*). They are always related to the currently active marker or delta marker of a display channel.

If no marker is enabled when calling the *MARKER SEARCH* menu, then the marker 1 is activated. Additionally, this menu contains functions for determination of the bandwidth, Q-factor and shape factor of band filters.

MARKER SEARCH menu:



The *SEARCH* softkey triggers the search for absolute extreme values for the active marker.

If the *MAX MODE* softkey is switched on, the function searches for the absolute maximum in the sweep range. If *MIN MODE* is active, the absolute minimum is searched for. If the bandfilter search mode is on (*BANDFILTER MODE*), the type of the search target depends on whether the *BANDPASS* or *BANDSTOP* softkey is on in the *DEFINE B'DFILTER* menu.

If the target mode is on (*TARGET MODE*), the search function will locate the first occurrence of the target from the beginning of the sweep.



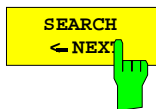
The *SEARCH NEXT* softkey starts the search for local extreme values.

If the *MAX MODE* softkey is on, the function searches for the next smallest local maximum in the sweep range, starting at the measured value at the actual marker position. Correspondingly, the function searches for the next largest local minimum when *MIN MODE* is active. If the bandfilter search mode is on (*BANDFILTER MODE*), the type of the search target depends on whether the *BANDPASS* or *BANDSTOP* softkey is on in the *DEFINE B'DFILTER* menu.

If the target mode is on (*TARGET MODE*), the search function cannot be operated.



The *SEARCH NEXT* → softkey searches for the next point which has a larger stimulus value than the active marker position.



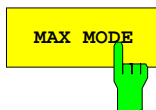
The *SEARCH* ← *NEXT* softkey searches for the next point which has a smaller stimulus value than the active marker position.



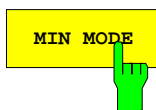
The *TRACKING* softkey causes the marker search function to be executed anew after each sweep.

The search is carried out in a specified locking range around the previous marker position. If more than one target is located in this range, then either the largest maximum, the smallest minimum, the target value or the bandfilter with the smallest stimulus value will be found.

The marker coupling (*MARKER MARKER-COUPLED MARKERS* softkey active) is switched off by *TRACKING*.



The *MAX MODE* softkey causes the maximum of the trace to be searched for when a marker search function is activated. If *MAX MODE* is activated from another search mode, a maximum search is started automatically.

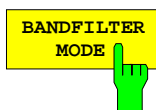


The *MIN MODE* softkey causes the minimum of the trace to be searched for when a marker search function is activated. If *MIN MODE* is activated from another search mode, a minimum search is started automatically.



The *TARGET MODE* softkey switches on the search for a fixed value. At the same time, the fixed target value may be input.

In cartesian diagrams, this is a y-coordinate, in circle diagrams, it is the radius. The unit of the entry depends on the current conversion and formatting of the trace. The search for the intersection of the line or circle with the trace is initiated via the *SEARCH* ← *NEXT* or *SEARCH NEXT* → softkey.

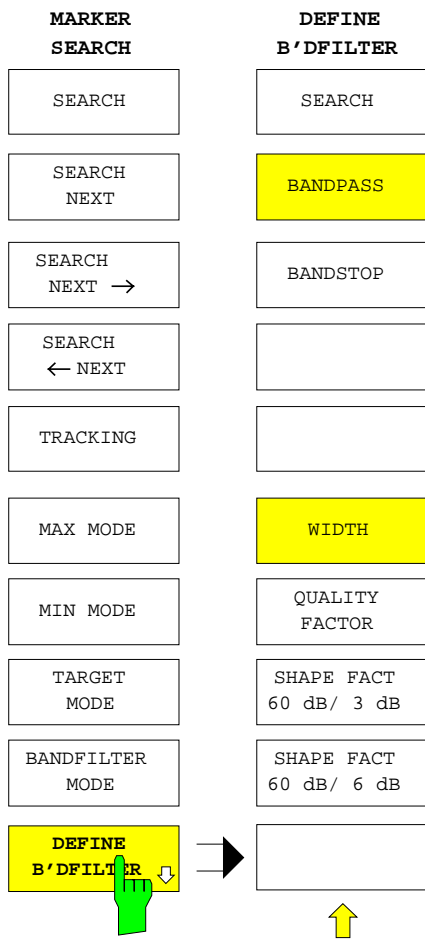


The *BANDFILTER MODE* softkey selects the characteristic quantity of the bandfilter specified in the *DEFINE B'DFILTER* menu as a search target

The marker is positioned at the next local extremum in the search direction which allows to determine the characteristic quantity. Note that not all extrema are suitable. It is for example necessary that the measured value sags by at least 60 dB on both sides of the minimum when the shape factor of a band-pass is to be determined. Otherwise an error message is displayed when the search is triggered.

In addition to the active marker, two or four temporary markers are positioned on specific bandwidth points.

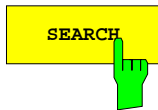
MARKER SEARCH - DEFINE B'DFILTER submenu:



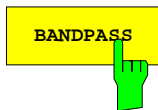
The *DEFINE B'DFILTER* softkey opens a submenu that is used to define the target of the bandfilter search.

This comprises the determination of

- the position of a band-pass or band-stop filter (*BANDPASS / BANDSTOP*),
- the bandwidth (*WIDTH*)
- the quality factor (*QUALITY FACTOR*),
- the shape factor (*SHAPE FACTOR*).



The *SEARCH* softkey starts the search for a target defined previously.



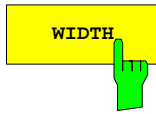
The *BANDPASS* softkey defines the DUT as a band-pass filter.

Bandwidth, Q-factor and shape factor will be determined accordingly. The active marker is positioned at a local maximum when the search is triggered.



The *BANDSTOP* softkey defines the DUT as a band-stop filter.

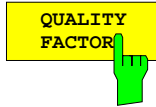
Bandwidth, Q-factor and shape factor will be determined accordingly. The active marker is positioned at a local minimum when the search is triggered.



The *WIDTH* softkey selects the bandwidth as search target.

The instrument searches for an extremum and for bandwidth points at which the measured values have changed by a specific user-defined amount compared to the extremum (e.g. when determining the 3-dB bandwidth).

After the search has been triggered using the softkeys *SEARCH* ← *NEXT* or *SEARCH* *NEXT* →, two temporary markers which are labeled "W" are displayed at the determined bandwidth points in addition to the active marker. The difference of the stimulus values of the temporary markers is displayed in the marker info list, directly below the response values of the active marker.

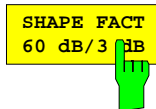


The *QUALITY FACTOR* softkey selects the quality factor as search target.

The search procedure is similar to the determination of the width via the *WIDTH* softkey. The measured value difference between the bandwidth points and the extremum is however set to the fixed value of 3 dB. The quality factor *Q* is calculated from the center frequency f_0 and the bandwidth $\Delta f_{3\text{ dB}}$ according to the formula

$$Q = f_0 / \Delta f_{3\text{ dB}}$$

Q is displayed in the marker info list below the response values of the active marker. The temporary markers positioned at the bandwidth points are labeled with "Q".

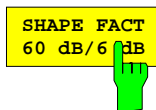


The *SHAPE FACT 60 dB / 3 dB* softkey switches on the search for the shape factor

$$F_{3\text{ dB}} = \Delta f_{60\text{ dB}} / \Delta f_{3\text{ dB}}$$

whereby $\Delta f_{3\text{ dB}}$ indicates the 3-dB bandwidth of the filter and $\Delta f_{60\text{ dB}}$ the 60-dB bandwidth.

The search procedure is similar to the search procedures described under the softkeys *WIDTH* and *QUALITY FACTOR*. However, the instrument searches for two additional bandwidth points which show a measured value difference of 60 dB from the extremum. In addition to the active marker, four temporary markers, labeled with "S", are displayed. The shape factor is displayed in the marker info list below the active marker values.



The *SHAPE FACT 60 dB / 6 dB* softkey switches on the search for the shape factor

$$F_{6\text{ dB}} = \Delta f_{60\text{ dB}} / \Delta f_{6\text{ dB}}$$

The search is performed analogous to the above-described search $F_{3\text{ dB}}$.

2.11.3 Delta Markers – DELTA Key

Delta markers are used to determine the difference of the stimulus and response values of markers to a so-called reference marker.

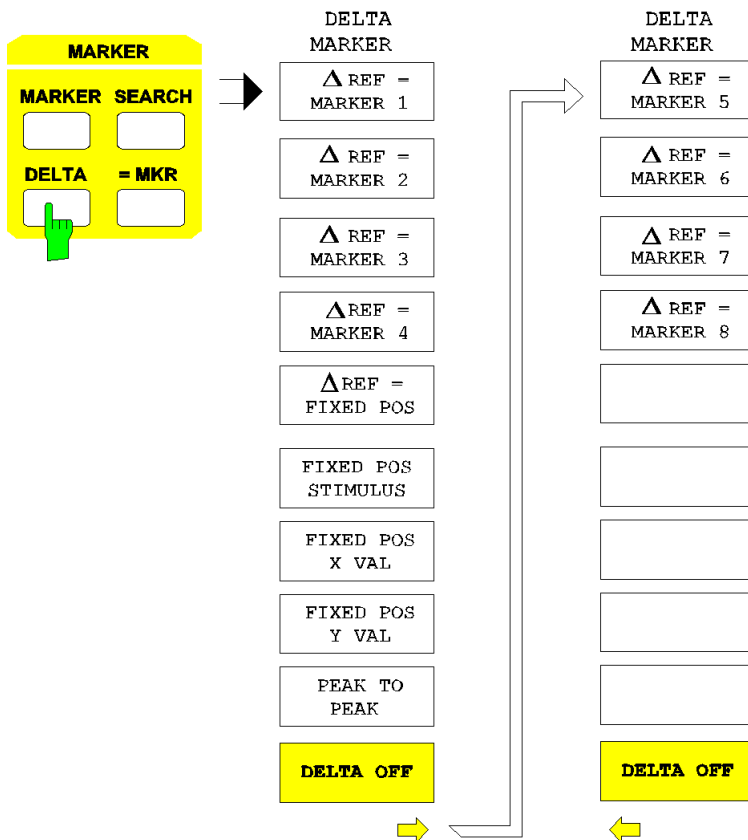
The *DELTA* key opens a menu offering the following options:

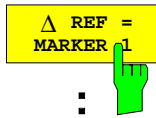
- One of the eight markers is defined to be the reference marker ($\Delta REF = MARKER 1, \dots, 8$).
- A freely movable reference marker is provided ($\Delta REF = FIXED POS$).
- The position of the reference marker can be defined numerically (*FIXED POS STIMULUS*, *FIXED POS X VAL*, *FIXED POS Y VAL*).
- In Cartesian diagrams, the peak-to-peak value and the average value of the measured value in a range defined by two markers is calculated (*PEAK TO PEAK*).
- The delta mode is left (*DELTA OFF*).

After the reference marker has been set, all enabled markers of the active display channel become delta markers. As usual, the reference marker is indicated on the trace by a triangle whose peak is facing down. Delta markers are on the other hand indicated by triangles whose peaks are facing up (uppercase Greek letter Delta).

The stimulus value of a delta marker is entered relative to a reference marker. In the same manner, the stimulus and response values are displayed in the information line and marker info list as the difference "delta marker minus reference marker". The values of the reference marker are on the other hand input and displayed as absolute values. With single point measurement (*SWEEP - SINGLE POINT* softkey is on), only the reference marker which may be freely positioned by the user is available.

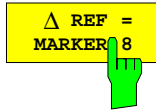
MARKER DELTA menu:





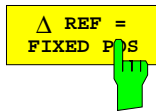
The $\Delta REF = MARKER 1$ softkey defines the marker 1 of the active display channel as a reference marker.

⋮



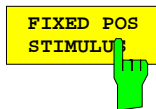
All other enabled markers in the active channel become delta markers. Markers 1 to 4 can be defined as reference markers in the main menu, the softkeys for the markers 5 to 8 are in the right supplementary menu.

Exit from the delta marker mode is possible via the softkey *DELTA OFF* or by deleting the reference marker.



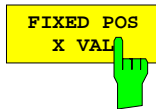
The $\Delta REF = FIXED POS$ softkey inserts marker with fixed position in the active display channel. In contrast to the reference markers 1 - 8, this marker is not bound to a trace.

The reference marker is identified by the letter F (F = FIXED) and can be positioned inside the displayed diagram by entering x- and y-coordinates. This reference marker is bound to the conversion and formatting with which it was defined.



The *FIXED POS STIMULUS* softkey activates the entry of an x-coordinate (stimulus value) of the fixed-position reference marker.

This is available in Cartesian diagrams.



The *FIXED POS X VAL* softkey activates the entry of an x-coordinate of the fixed-position reference marker.

This is available in circle diagrams.



The *FIXED POS Y VAL* softkey activates the entry of an y-coordinate of the fixed-position reference marker.

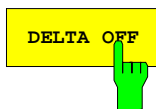
This is available in circle diagrams.



The *PEAK TO PEAK* softkey activates a statistical function which determines the average value of the measured value and the difference between the maximum and minimum measured value (peak-to-peak value) the range between the active marker and the reference marker.

Both results are displayed in the marker info list. If the delta mode is disabled, the two values are determined over the complete sweep.

The *PEAK TO PEAK* is available in Cartesian diagrams only. If two traces are displayed in the active display channel, *PEAK TO PEAK* can only be operated when the active marker and the reference marker are both positioned on the same trace.



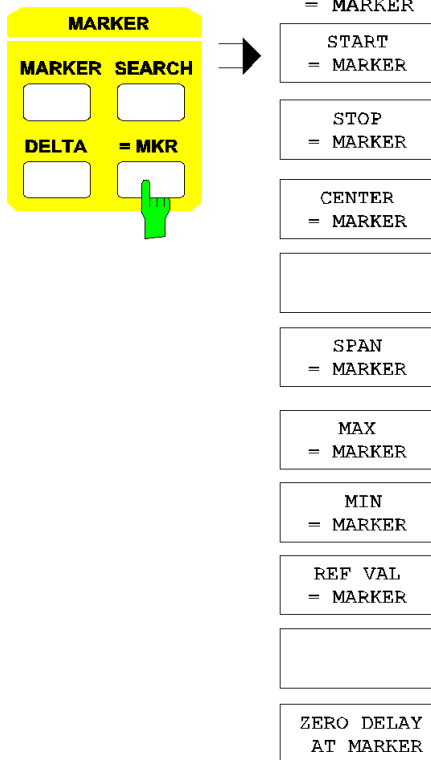
The *DELTA OFF* softkey exits the delta mode.

All delta markers and reference markers (except for the *FIXED MARKER*) become normal markers again. The *FIXED MARKER* is deleted.

This function is provided in the right supplementary menu, too.

2.11.4 Marker Assignment Functions – = MKR Key

MARKER = MKR menu:



The = MKR key opens a menu where the stimulus or measured values of the last active marker or delta marker are assigned to specific parameters.

The following parameters may be defined:

- Start, stop and center value of the sweep range ($START = MARKER$, $STOP = MARKER$, $CENTER = MARKER$). This is equivalent to defining the sweep range by means of the *STIMULUS* key group.
- Maximum, minimum and specific reference value of the trace ($MAX = MARKER$; $MIN = MARKER$, $REF VAL = MARKER$). This corresponds to scaling the diagram with the *RESPONSE SCALE* key.
- The measurement plane corresponding to the measured quantity can be shifted such that the group delay at the marker position is cancelled (*ZERO DELAY AT MARKER*).

The functions in the = MARKER menu can only be operated when at least one marker is on. If stimulus values are to be assigned, the single point measurement mode (*SWEEP - SINGLE POINT*) and the sweep list (*SWEEP - LIST SWEEP*) must be inactive. Vertical or radial scaling values can't be assigned with segmented Cartesian (*DIAGRAM - SEGMENTED CARTESIAN*) or polar (*DIAGRAM - SEGMENTED POLAR*) diagrams.

Note: In the *ARBITRARY* mode of option ZVR-B4, the frequency values of markers may differ from the sweep scaling of the measurement diagram. The marker position and the allocations for *START*, *STOP* and *CENTER*, however, always refer to the *BASE FREQUENCY* (see section 2.4.1.3.3).



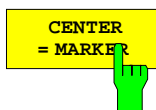
The *START = MARKER* softkey sets the start value of the sweep equal to the stimulus value of the active marker.

The active marker is thus located at the beginning of the trace.



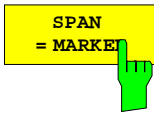
The *STOP = MARKER* softkey sets the stop value of the sweep equal to the stimulus value of the active marker.

The active marker is thus located at the end of the trace.



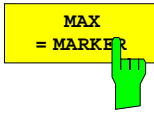
The *CENTER = MARKER* softkey sets the center value of the sweep equal to the stimulus value of the active marker.

The active marker is thus located in the middle of the trace.



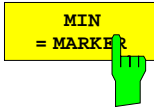
The *SPAN = MARKER* softkey sets span equal to the width of the range between the active delta marker and the reference marker.

This function is only available in the delta mode.



The *MAX = MARKER* softkey sets the maximum value of the diagram equal to the measured value of the active marker.

This softkey can't be operated with charter diagrams.



The *MIN = MARKER* softkey sets the minimum value of a Cartesian diagram equal to the measured value of the active marker.

This softkey can't be operated with circle diagrams.



The *REF VAL = MARKER* softkey sets the reference value of the diagram equal to the measured value of the active marker.

This softkey can't be operated with smith or charter diagrams.

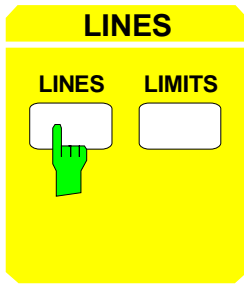


The *ZERO DELAY AT MARKER* softkey arithmetically shifts the measurement plane assigned to the measured quantity until a group delay of 0 sec. results at the current marker position.

The measurement plane assigned to the measured quantity is the port at which the wave quantities in the numerator are measured, e. g. PORT 1 for S_{11} and S_{12} , PORT 2 for S_{21} and S_{22} . The resulting length offset of the measurement plane can be accessed using the softkeys *DELAY TIME*, *ELECTRICAL LENGTH* and *MECHANICAL LENGTH* in the menu of the *OFFSET* key.

ZERO DELAY AT MARKER can only be operated when the *GROUP DELAY* format is on in the active display channel.

2.12 Display and Limit Lines – *LINES* Key Group

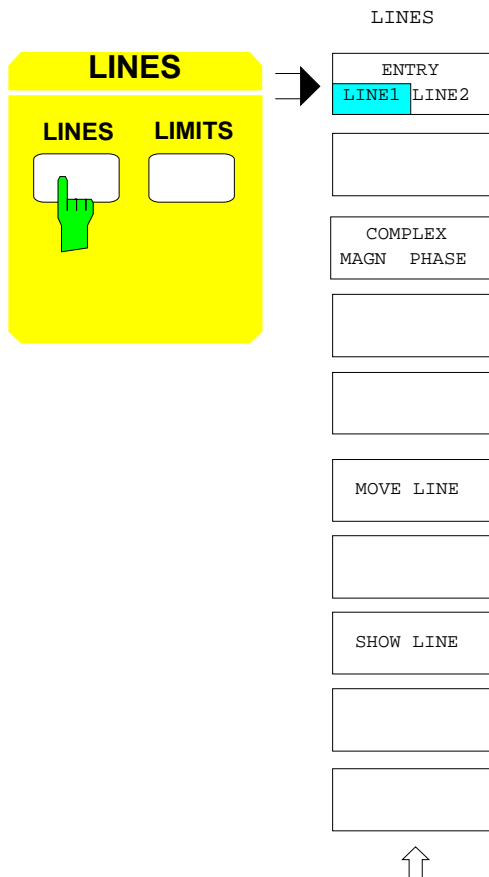


The *LINES* key group comprises the *LINES* and *LIMITS* keys. These keys provide auxiliary lines which make the evaluation of the trace easier.

- The *LINES* key provides display lines for measuring absolute values and differences on the trace.
- The *LIMITS* key provides limit lines. They are used to check whether the measured values lie inside of a specific interval.

2.12.1 Display Lines – *LINES* Key

Display lines are utilities which, similar to markers, make the evaluation of a measurement curve more convenient. The function of display lines is similar to that of a movable scale which can be used to measure absolute and differential values on measurement curves.



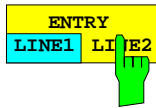
The *LINES* key opens a menu where display lines are set:

- A maximum of two display lines can be activated in each display channel (*ENTRY LINE1/LINE2*).
- In circular diagrams, either circles around the origin with variable radius or rays from the origin with variable angle position are available (*COMPLEX MAGN/PHASE*).
- In Cartesian diagrams, the lines are displayed as horizontal lines over the full width of the diagram and they are movable in the y-direction (*MOVE LINE*).
- When a display line is switched on (*SHOW LINE*) an info field as activated.

Both display lines are labeled D1 and D2. This labeling is displayed on radial and horizontal (Cartesian) lines. On horizontal lines, the current y-position is indicated in addition.

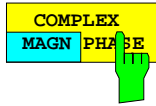
If the conversion or formatting of the measured value changes, the display lines of the active display channel are deactivated and no longer displayed. Transitions between linear, logarithmic and segmented axis are, however, permitted.

A switchover to another sweep mode (*SYSTEM MODE - SWEEP TYPE*), causes the settings of the display line as well as other diagram-specific parameters to be stored until the sweep mode is called again.



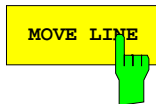
The *ENTRY LINE1 LINE2* softkey defines which of the two display lines is affected by the operating functions of the *LINES* menu.

The default setting is *LINE1*.



The *COMPLEX MAGN PHASE* softkey defines which kind of display lines are used in circle diagrams.

In the default setting *MAGN* the display line is a circle around the origin with any radius, whereas *PHASE* activates a ray hinged at the origin with any angle position.

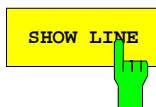


The *MOVE LINE* softkey activates the entry of the position of the display line in axis units of the current diagram.

The following values may be entered:

- In Cartesian diagrams, the y-position. The default position is half the diagram height.
- In circular diagrams and in the *MAGN* position of the softkey *COMPLEX MAGN/PHASE*, the radius of an amplitude circle. The default radius of an amplitude circle is half the diagram radius.
- In circular diagrams and in the *PHASE* position of the softkey *COMPLEX MAGN/PHASE*, the angle of a radial ray. The default angle 0° .

The lines may be moved even beyond the edge of the diagram. In this case, the inscription which is provided with an arrow facing in the direction of the edge exceeded remains visible on the margin of the diagram.



The *SHOW LINE* softkey switches on or off the display line.

The default state is the switch-off state. Settings of the display line can only be made when the line is switched on.

2.12.2 Limit Lines – *LIMITS* Key

Limit lines can be used in Cartesian or circle diagrams in order to check whether the parameters of a DUT adhere to defined limits. A typical application is the check for adherence to specifications.

If the limit check is activated,

- a message is displayed on the screen if the limits are exceeded,
- the section of the trace which is outside the limits is displayed in another color,
- an acoustic warning can be output in addition.

The *LIMITS* key opens a menu for managing limit lines. It allows to

- switch on specific limit lines (*SELECT LINE*), rename (*EDIT NAME*) and copy them to other limit lines (*COPY LINE*),
- define limit lines in circle diagrams (*DEFINE CIRCLE*) and in Cartesian diagrams (*DEFINE SECTIONS*),
- move display lines (*MOVE LINE*),
- switch on the display (*SHOW LINE*) of the current limit line on screen and the limit check (*LIMIT CHECK*).

In total, up to eight different limit lines can be defined. Only one limit line can be selected per display channel but the same line may be assigned to various channels simultaneously. Modifications of definitions, i.e., entries in the submenus *DEFINE CIRCLE*, *DEFINE SECTIONS* and *MOVE LINE* as well as via the *EDIT NAME* softkey, apply for the active display channel. If the limit line is assigned to various display channels, these entries apply for all channels in which this limit line is used.

Limit lines depend on the axis labels of the diagram which they have been defined in, i.e., on the respective sweep mode, the conversion and formatting of the measured value, and an eventually logarithmic scale. A modification of these parameters causes the limit line to be switched off.

On the other hand, rescaling or segmenting of the axes, zooming and the transition between various circle diagrams is permitted. The limit lines are adapted, accordingly.

2.12.2.1 Selecting and Switching On Limit Lines

The *SELECT LINE* softkey switches on and off the *SELECT LINE* table. By default, the softkey is not active and the table is not displayed.

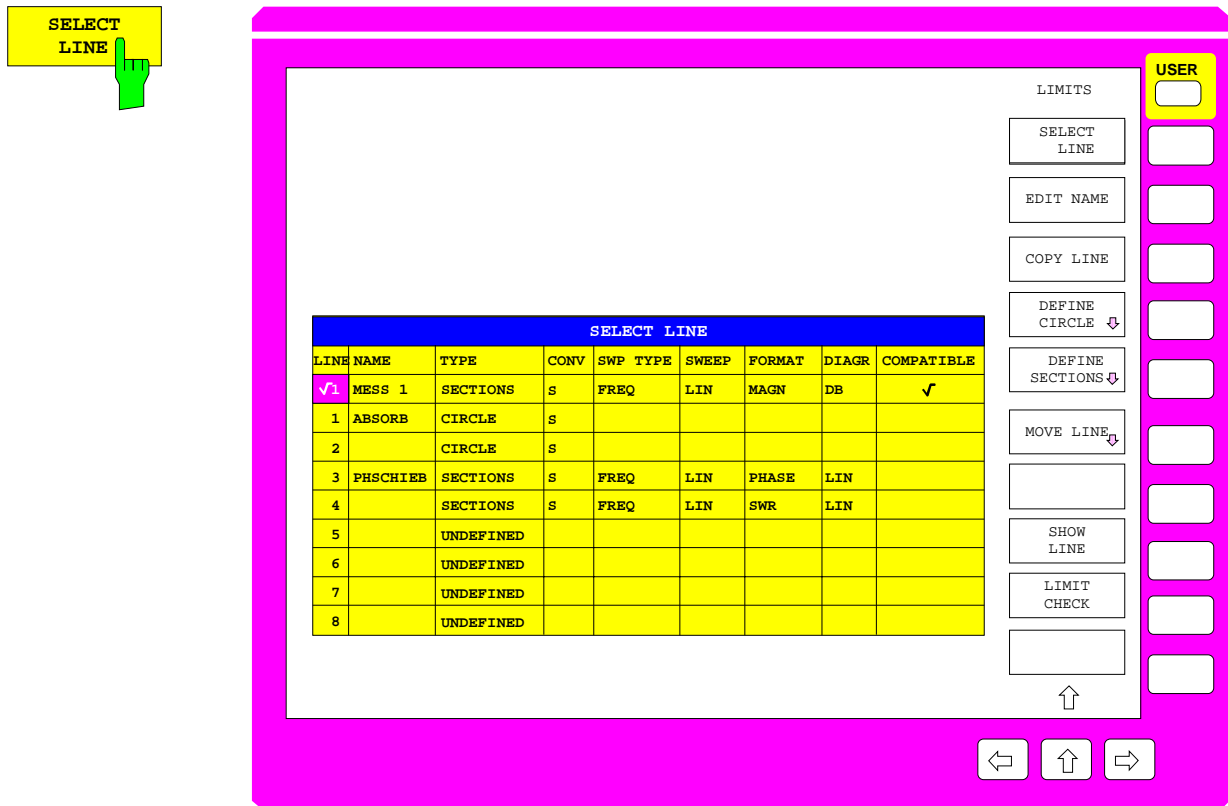


Fig. 2-34 Selection of limit lines

The *SELECT LINE* table contains nine columns. Only the first one can be edited:

LINE –limit line number

A checkmark in this column shows which line is currently selected. If one of the units prefix keys is pressed while the selection bar is located in the *LINE* field, the corresponding limit line is selected.

NAME – name of the limit line

Limit lines can be renamed via the *EDIT NAME* softkey.

TYPE – type of tolerance sections

SECTIONS for tolerance bands in Cartesian diagrams consisting of line sections,

CIRCLE for tolerance circles used in circle diagrams,

UNDEFINED in the default state and after a line has been deleted (in this case, all fields except *LINE* and *TYPE* are empty).

CONV – associated conversion of measured value

SWP TYPE – (only for TYPE = SECTIONS) associated sweep mode

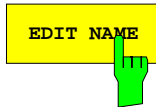
SWEEP – (only for TYPE = SECTIONS) associated grid

FORMAT – (only for TYPE = SECTIONS) associated formatting of measured value

DIAGR – (only for TYPE = SECTIONS) associated division of the x-axis

COMPATIBLE – Indication of compatibility

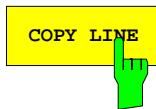
A checkmark in this column indicates that the setting parameters of the limit line are compatible with the current setting, i.e., the table columns *TYPE* to *DIAGR* comply with the current instrument settings. In this case only, the line can be switched on via *SHOW LINE* and a limit check can be performed.



The *EDIT NAME* softkey calls the auxiliary line editor for entry of the name of the active limit line.

This name, which is maximally 8 characters long, is useful when trying to locate a limit condition which was previously entered in the *SELECT LINE* table.

EDIT NAME can only be operated when the selected limit line is defined.



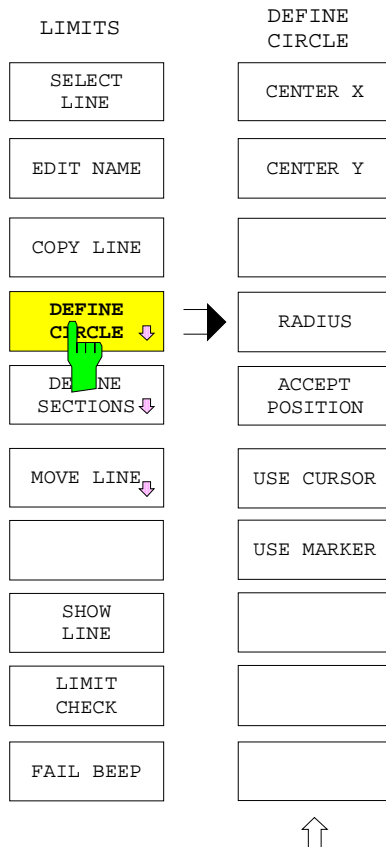
The *COPY LINE* softkey copies the currently selected limit line onto another line.

The number of the other line (between 1 and 8) must be entered. *COPY LINE* can only be operated when the currently selected limit line is defined.

If an existing line is to be overwritten, the *COPY LINE* function must be confirmed before.

2.12.2.2 Defining a Limit Line in a Circular Diagram

LINES LIMITS submenu:



The *DEFINE CIRCLE* softkey calls a submenu for definition of a limit line in a circular diagram.

In this type of diagram, limit lines are tolerance circles whose center and radius can be freely defined. These parameters can be entered in different ways:

- entry via the softkeys *CENTER X*, *CENTER Y*, *RADIUS*,
- entry via a graphic editing utility. The center coordinates of the tolerance circle are taken directly from this utility as soon as *ACCEPT POSITION* is activated.

The following two editing utilities are provided:

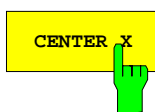
- a freely movable cursor (*USE CURSOR*) in form of a cross which can be moved via the cursor keys and the roll-key.
- a temporary marker which is identified by the number 8 and is different from the regular markers operated via the *MARKER* key group. This function (*USE MARKER*) is particularly suitable if the limit line is to be constructed using an ideal trace.

The x- and y-coordinates of both editing utilities are indicated in the bottom line of the marker info field in the axis units of the respective diagram. If no info field is displayed, the coordinates are displayed at the position of the info field.

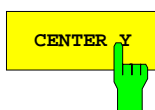
A continuously updated "rubber circle" is displayed additionally in conjunction with the two graphic editing utilities. It corresponds to the tolerance circle which would be generated by activating *ACCEPT POSITION* depending on the current position of the editing utility and the set radius.

The *SHOW LINE* softkey is switched on automatically in order to graphically illustrate the editing procedure.

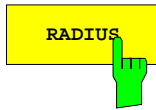
If a line which has already been defined should be overwritten, the redefinition must be confirmed.



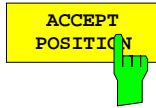
The *CENTER X* softkey activates the entry of the x-coordinate of the tolerance-circle center in diagram units.



The *CENTER Y* softkey activates the entry of the y-coordinate of the tolerance-circle center in diagram units.

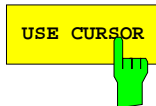


The *RADIUS* softkey activates the entry of the radius of the tolerance circle in diagram units.



The *ACCEPT POSITION* softkey takes the position of the graphic editing utility as center of the tolerance circle.

As long as one of the two softkeys *USE CURSOR* or *USE MARKER* is active, the graphic editing utility is either a cursor in the form of a cross or a marker which is labeled with an "8".



The *USE CURSOR* softkey provides the freely movable cursor (in the form of a cross) as a graphic editing utility. Its default position is in the center of the diagram.

The cursor can be moved via the cursor keys and the roll-key and disappears when the cursor is switched off or when the menu is exited. The cursor coordinates are taken as center of the tolerance circle using the *ACCEPT POSITION* softkey.



The *USE MARKER* softkey provides the temporary marker numbered 8 as a graphic editing utility. Its default position is the beginning of the sweep.

Like other markers, this marker can be positioned over the associated entry window, however, it is deleted as soon as the *LINES LIMITS* submenu is left and can therefore not be operated like a regular marker via the *MARKER* key field. While *USE MARKER* is active, the sweep assumes the hold state and the regular marker no. 8 can not be displayed. The marker coordinates are taken as center of the tolerance circle using the *ACCEPT POSITION* softkey.

2.12.2.3 Defining a Limit Line in a Cartesian Diagram

The *DEFINE SECTIONS* softkey opens a menu defining the characteristic of the currently active limit line in a Cartesian diagram.

In this type of diagram, limit lines consist of a maximum of 20 sections. Each section is specified by two pairs of reference points, located at the x-coordinates *START* and *STOP*, and defining each an upper and lower limit in the y-direction. The limits inside a section are defined by the equations of the two lines connecting the upper and the lower reference points.

Note: *Depending on the scale of the diagram, these two straight lines are not necessarily identical with the shortest graphical connection of the points (see SWEEP SWEEP - DEF SWEEP LIST). If a line exceeds a segment limit in the x- or y-direction, break-points may occur on the screen display due to different grid increments, or parts of the lines may be shifted due to gaps between the segments. This effect is, however, only visible in the final display and not while editing with rubber lines.*

The sections need not necessarily be connected, i.e., form continuous polygonal lines. However, they must not overlap in the x-direction. The pair of lines may be reduced to a pair of points if the x-coordinates for the start and stop points coincide. If this is the case, the upper and lower limits are identified by hooks ("v" and "^").

The reference points for the sections can be entered in different ways:

- Entry via the *LINE SECTIONS* table (see below) which can be edited is displayed with calling the menu. In this table, sections can be deleted (*DEL ALL SECTIONS*, *DEL ACTIVE SECTION*) and inserted (*INS NEW SECTION*). Moreover, an arbitrary section can be activated (*GOTO SECTION #*).
- Entry using graphic editing utilities the position of which is taken as a reference point using *ACCEPT POSITION*.

Graphic editing utilities are:

- a freely movable cursor (*USE CURSOR*) in the form of a cross which can be moved with the cursor keys or with the roll-key,
- a temporary marker (*USE MARKER*) which is identified by the number 8. The temporary marker does not affect the regular markers operated via the *MARKER* key group and is deleted as soon as the *LINES LIMITS* submenu is left. This function is particularly suitable if the limit line is to be constructed as tolerance band around an ideal trace.

The *SHOW LINE* softkey is switched on automatically in order to graphically illustrate the editing procedure.

Entry via the *LINE SECTIONS* table is the default setting. In this case, the pairs of reference points can be entered either by specifying the upper and lower y-values (*UPPER LIM/LOWER LIM*) or the middle value and allowed y-deviation (*MIDDLE VAL/DELTA LIM*).

The x- and y-coordinates of both editing utilities are indicated in the bottom line of the marker info field in the axis units of the respective diagram. If no info field is displayed, the coordinates are displayed at the position of the info field.

Two continuously updated "rubber lines" are displayed additionally in conjunction with the two graphic editing utilities. These lines correspond to the upper and lower limit line in the active section, which would be generated when pressing *ACCEPT POSITION* with the current settings. "Rubber lines" are drawn only, if the table contains at least one section.

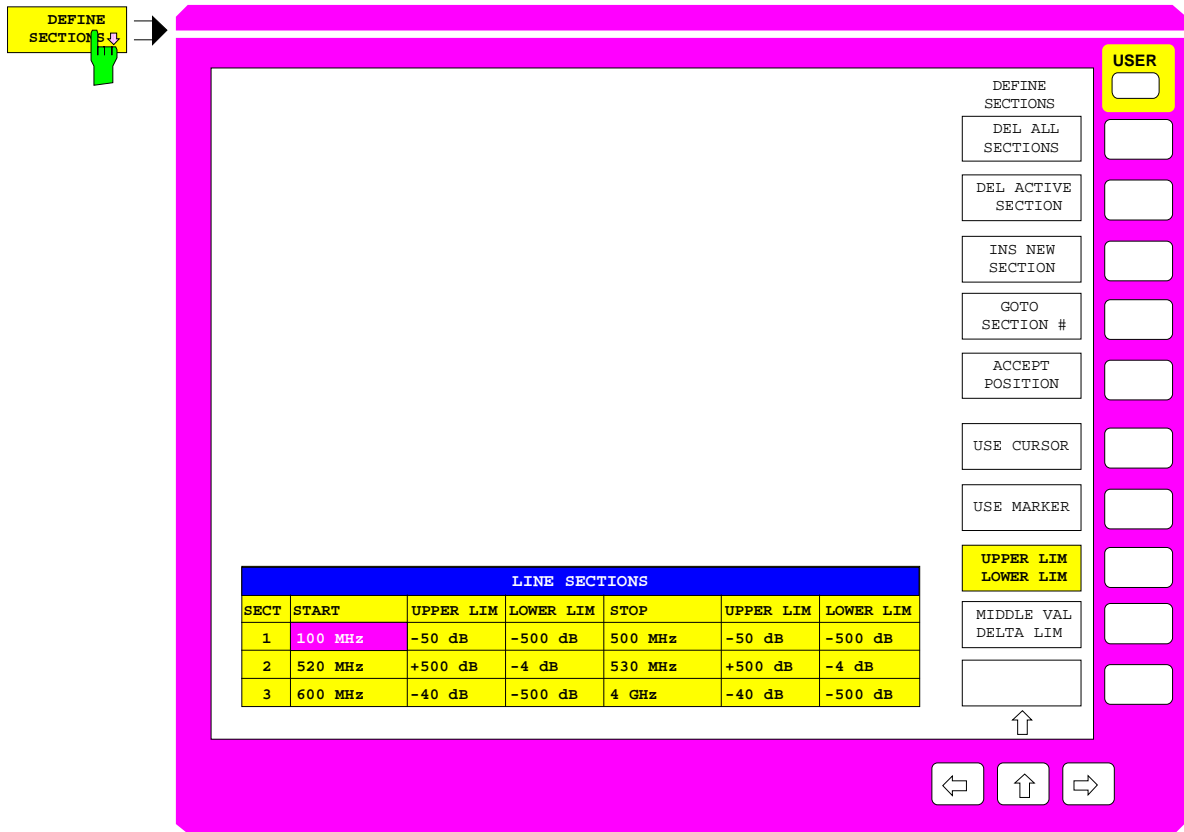


Fig. 2-35 Defining a limit line in a Cartesian diagram

The *LINE SECTIONS* table contains the current number of the section and six columns which can be edited.

SECT - number of section

START - abscissa (x-value) of the beginning of the section

STOP - abscissa of the end of the section

- If the *UPPER LIM/LOWER LIM* softkey is active:

UPPER LIM - upper ordinates (y-values)

Ordinates of the upper reference points at the beginning and end of the section

LOWER LIM - lower ordinates

Ordinates of the lower reference points at the beginning and end of the section.

- If the *MIDDLE VAL/DELTA LIM* is active:

MIDDLE VAL – rated value

Rated value of the tolerance band at the beginning and end of a section.

DELTA LIM - width

Width of the tolerance band at the beginning and end of a section.



The *DEL ALL SECTIONS* softkey deletes all sections in the line sections table. Prior to deletion, a request to confirm the action is displayed.

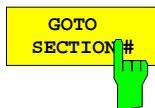


The *DEL ACTIVE SECTION* softkey deletes the active section. The active section is where the cursor is positioned within the table.



The *INS NEW SECTION* softkey inserts a new section before the active section which is marked by the cursor.

This is possible only, if the permitted total amount of 20 sections is not exceeded. Default values are entered into the new fields of the table.



The *GOTO SECTION #* activates the indicated section.

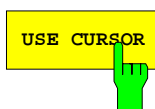
It moves the cursor of the table vertically into the corresponding line. The column position of the cursor does not change.



The *ACCEPT POSITION* softkey enters the position of the graphic editing utility (see *USE CURSOR* or *USE MARKER*) into the selected field.

When a graphic editing utility is switched on the cursor on the table is positioned in one of the fields *UPPER LIM*, *LOWER LIM* or *MIDDLE VAL*. Activating *ACCEPT POSITION* causes the current y-coordinates of the cursor or marker to be entered into this field, the x-value is entered into the associated *START* or *STOP* field. The cursor is automatically positioned to the next field of the same name. If it is positioned, e.g., to *UPPER LIM* at the start of a section, it is positioned to *UPPER LIM* at the end point.

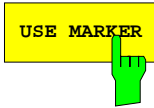
If the end of the last section is reached, a new section with the corresponding default values is added automatically until the maximum of 20 sections is reached. A new section is also inserted, if the *ACCEPT POSITION* softkey is used with an empty table. This case is handled as if a default section had been inserted before and the cursor had been positioned to the *UPPER LIM* or *MIDDLE VAL* field.



The *USE CURSOR* softkey provides a freely movable cursor in the form of a cross as a graphic editing utility. Its default position is the center of the diagram.

The cursor can be moved via the cursor keys or the roll-key. The cursor coordinates are entered into the selected table field using the *ACCEPT POSITION* softkey. If *USE CURSOR* is activated, the cursor of the table can no longer be moved using the cursor keys or the roll-key. Therefore, an automatic step mechanism for the cursor is activated simultaneously. If the cursor is positioned to the *START*, *STOP* or *DELTA LIM* fields, it moves to the associated fields *UPPER LIMIT* or *MIDDLE VAL*. Cf. *ACCEPT POSITION* softkey for further information on the cursor advancement.

After disabling *USE CURSOR*, the temporary cursor disappears and the cursor in the table can again be moved as usual.

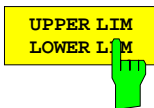


The *USE MARKER* softkey switches on a temporary marker which is displayed as graphic editing utility and labeled by the number 8. Its default position is the beginning of the sweep.

Similar to other markers the temporary marker can be positioned over the associated entry field, however, it can not be operated like a regular marker via the *MARKER* key group. While *USE MARKER* is active, the sweep assumes the hold state and it is not possible to simultaneously display the regular marker no. 8. The marker coordinates are accepted for the selected table field using the *ACCEPT POSITION* softkey.

As soon as *USE MARKER* is enabled, the table cursor can no longer be moved via the cursor keys or the roll-key. Therefore, an automatic step mechanism for the cursor is activated with enabling the softkey. If the cursor is positioned on the *START*, *STOP* or *DELTA LIM* fields, it moves to the associated fields *UPPER LIMIT* or *MIDDLE VAL*. Cf. *ACCEPT POSITION* softkey for further information on the cursor advancement.

The temporary marker disappears after disabling *USE MARKER* and the table cursor can be moved as usual.



The *UPPER LIM/LOWER LIM* softkey is switched alternately with the *MIDDLE VAL/DELTA LIM* softkey and defines the display of the *LINE SECTIONS* table. *UPPER LIM/LOWER LIM* is the default setting.

If this softkey is switched on, the *START* and *STOP* columns are followed by the columns *UPPER LIM* and *LOWER LIM*, respectively. This type of table display is particularly appropriate for the independent entry of upper (*UPPER LIM*) and lower limit (*LOWER LIM*) values. Switching over from *MIDDLE VAL/DELTA LIM* to *UPPER LIM/LOWER LIM* causes the previous table data to be converted, correspondingly.

If the table is already displayed in the form "upper/lower limit" and if a graphic editing utility is active (*USE CURSOR* or *USE MARKER* switched on), *UPPER LIM LOWER LIM* has the following additional function: If a field in the *UPPER LIM* column of the *LINE SECTIONS* table is selected, the softkey switches to the corresponding *LOWER LIM* field and vice versa.



The *MIDDLE VAL/DELTA LIM* softkey is switched alternately with the *UPPER LIM LOWER LIM* softkey and defines the display of the *LINE SECTIONS* table.

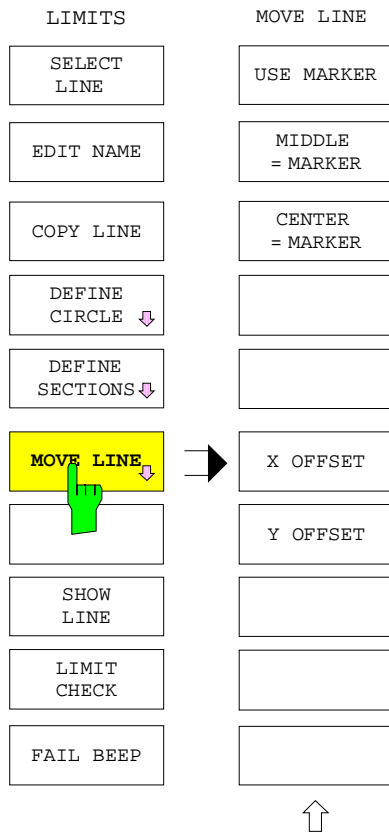
If this softkey is switched on, the *START* and *STOP* columns are followed by the columns *MIDDLE VAL* and *DELTA LIM*. This type of table display is particularly appropriate for the entry of specifications which contain a rated value (*MIDDLE VAL*) and a maximum symmetrical deviation (*DELTA LIM*). Switching over from *UPPER LIM LOWER LIM* to *MIDDLE VAL DELTA LIM* causes the previous table data to be converted, correspondingly.

Note: *MIDDLE VAL* is always the arithmetic means of upper and lower limit value in current units of the y-axis. This implies that with logarithmic or segmented y-scaling the value of *MIDDLE VAL* is not graphically centered between the upper and lower tolerance lines.

If the table is already displayed in the form "middle value/delta" and if a graphic editing utility is active (*USE CURSOR* or *USE MARKER* switched on), *MIDDLE VAL DELTA LIM* has the following additional function: If a field in the *MIDDLE VAL* column of the *LINE SECTIONS* table is selected, the softkey switches to the corresponding *DELTA LIM* field and vice versa.

2.12.2.4 Moving a Limit Line

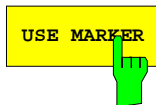
LINES LIMITS - MOVE LINE submenu:



The *MOVE LINE* softkey opens a submenu which allows for moving limit lines.

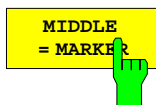
- The circle or tolerance band may be centered with reference to a point of the trace with a temporary marker (*MIDDLE = MARKER*, *CENTER = MARKER*). This marker is assigned the number 8. If, e.g., a trace in a Cartesian diagram has the correct shape but is offset in the y-direction, the limit line can be adapted with the centering function.
- Limit lines can also be arbitrarily shifted in the x- and y-directions (*X OFFSET*, *Y OFFSET*).

The *MOVE LINE* menu can be called only, if the selected limit line is displayed, i.e., if *SHOW LINE* is activated.



The *USE MARKER* softkey causes a temporary marker labeled 8 to be displayed as a graphic editing utility. Its default position is the beginning of the sweep range.

Similar to other (regular) markers, this marker can be positioned over the associated entry field, however, it can not be operated via the *MARKER* key group. If the temporary marker is active, the regular marker no. 8 cannot be displayed.

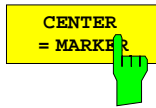


The *MIDDLE = MARKER* softkey centers the active limit line interpreted as a tolerance band on the trace.

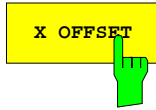
To this end, the arithmetic means between upper and lower limit of the limit line is set equal to the y-coordinate of the temporary marker

Note: *The trace at the marker position doesn't graphically appear in the middle between upper and lower tolerance line when the y-axis is segmented or logarithmically scaled.*

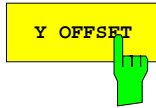
If no section is defined at the current stimulus value of the temporary marker 8, the tolerance band is centered relative to the end coordinate of the preceding section. If no section exists before the current marker position, the start coordinates of the first section defined are used.



The *CENTER = MARKER* softkey centers the active limit line interpreted as a tolerance circle on the position of the temporary marker.



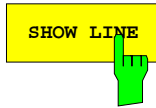
The *X OFFSET* softkey activates the entry of an offset in the x-direction for the active limit line.



The *Y OFFSET* softkey activates the entry of an offset in the y-direction for the active limit line.

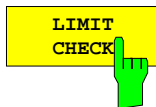
2.12.2.5 Display and Limit Check

LINES LIMITS menu:



The *SHOW LINE* softkey switches on and off the display of the active limit line.

A line may only be switched on when it is compatible with the current diagram (see the *COMPATIBLE* field in the *SELECT LINE* table). A limit check can only be performed, when the limit line is displayed. Deactivating *SHOW LINE* causes *LIMIT CHECK* and *FAIL BEEP* to be deactivated, too.



The *LIMIT CHECK* softkey is used to switch on and off the limit check.

With limit check being activated, a number of warnings are displayed as soon as a measured value lies outside the specified limits:

- The FAIL warning is displayed.
- The trace changes its color in the range outside the limits (the color change can be set via *DISPLAY - CONFIG DISPLAY - COLORS*).
- The FAIL bit of the user port is set. The FAIL bit is set for at least 1 ms not later than 1 ms after limit violation.

LIMIT CHECK can be activated only, when the limit line is displayed (*SHOW LINE*). Switching off *LIMIT CHECK* causes the *FAIL BEEP* to be deactivated, too.

2.13 Selection of Display Channel – CHANNEL Group

The CHANNEL key group provides four independent display channels which can be selected by means of keys CH1 to CH4. The currently active display channel is indicated by the LED above the corresponding key.

Offering a choice of four display channels, a single Network Analyzer ZVR turns into four practically independent units, which may differ in a variety of parameters and can conveniently be selected.

Note: These display channels **are not identical** with the measurement channels (the ZVR, ZVC, ZVK and ZVM have four) for the test parameters a_1 , a_2 , b_1 and b_2 . The measurement channels can be set in the RESPONSE MEAS -INPUT menu.

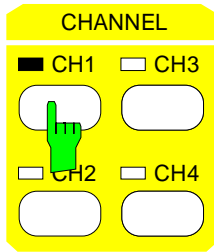
ZVR, ZVRE, ZVC, ZVCE, ZVK, ZVM For models with bidirectional test set, the S parameters are assigned to the keys CH1 to CH4 such that the arrangement of the keys corresponds to the position of the four S parameters in the scattering matrix. Because the S parameter S_{21} is assigned to channel 2, the CH2 key is located in the lower left portion of the key group. The CH3 key (S_{12}) is on the other hand located in the upper right portion.

| Display channel | measured quantity | format |
|-----------------|-------------------|-----------|
| CH1 | S_{11} | complex |
| CH2 | S_{21} | magnitude |
| CH3 | S_{12} | magnitude |
| CH4 | S_{22} | complex |

ZVRL ZVRL can measure the S parameters S_{11} and S_{21} only. The default state corresponds to the following assignments:

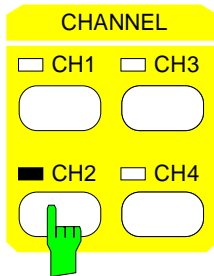
| Display channel | measured quantity | representation/format |
|-----------------|-------------------|-----------------------|
| CH1 | S_{11} | complex |
| CH2 | S_{21} | magnitude |
| CH3 | S_{12} | group delay |
| CH4 | S_{22} | standing wave ratio |

The setting parameters of the network analyzer can be divided into three categories: global, channel-specific and parameters that can be coupled. Global parameters act on all channels, channel-specific parameters on the channel in question. In the case of parameters that can be coupled the user can define if they should be global or channel-specific. This is done by means of the SWEEP SWEEP - COUPLED CHANNELS softkey. For assignment of parameters to the three above categories please refer to the description of this softkey.



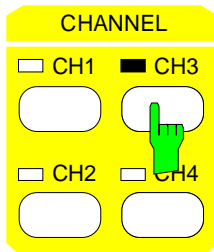
The *CH1* key selects channel 1 as the active display channel and switches the LED above the key on.

Assignment in the default setting:
 S_{11} , *COMPLEX* formatting



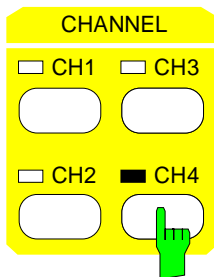
The *CH2* key selects channel 2 as the active display channel and switches the LED above the key on.

Assignment in the default setting:
 S_{21} , *MAGNITUDE* formatting



The *CH3* key selects channel 3 as the active display channel and switches the LED above the key on.

Assignment in the default setting:
 S_{12} , *MAGNITUDE* formatting
 Exception ZVRL: S_{21} , *GROUP DELAY* formatting

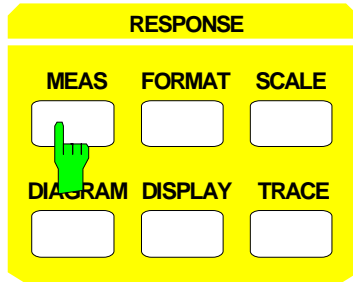


The *CH4* key selects channel 4 as the active display channel and switches the LED above the key on.

Assignment in the default setting:
 S_{22} , *COMPLEX* formatting
 Exception ZVRL: S_{11} , standing wave ration (*SWR*) formatting

2.14 Configuring of Measured-Value Display – RESPONSE Key Group

The *RESPONSE* key group comprises the *MEAS*, *FORMAT*, *SCALE*, *DIAGRAM*, *DISPLAY* and *TRACE* keys. They are used to define the display of measured values.



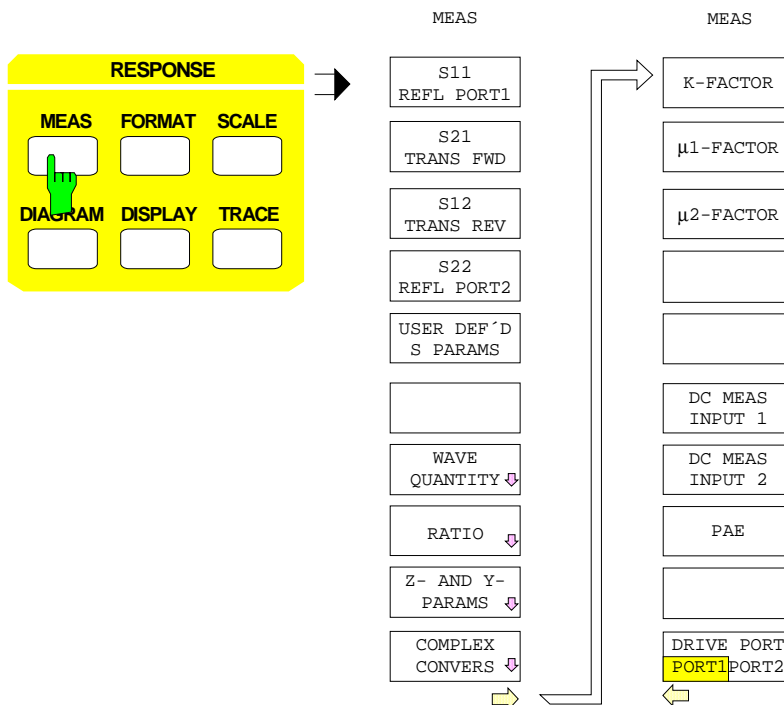
- The *MEAS* key selects the measured quantity in the active display channel,
- the *FORMAT* key determines the format the measured quantity is displayed in,
- the *SCALE* key defines the scaling of the measured diagram,
- the *DIAGRAM* key selects the type of diagram and its representation,
- the *DISPLAY* key configures the screen display of diagrams globally.
- the *TRACE* allows to store and mathematically manipulate the trace.

2.14.1 Selection of the Measured Quantity – MEAS Key

The *MEAS* key opens a menu for selecting the measured quantity for the active display channel.

The following options are provided:

- Default setting, where the four S-parameters of a two-port are assigned to the four display channels as described under the *CHANNEL* key group (*S11 FWD REFL*, ... , *S22 REV REFL*).
- Redefinition of the S parameters (*USER DEF'D S-PARAMS*). This is only possible in the external mode of the models in the *ZVR* and *ZVC* families.



- Direct measurement of wave quantities (*WAVE QUANTITY*).
- Calculation of any desired ratios of wave quantities (*RATIO*).
- Calculation of absolute or normalized two-port Z or Y parameters from the four S parameters (*Z AND Y PARAMS*).
- Conversion of a single S parameter into another complex quantity (*COMPLEX CONVERS*).
- Calculation of stability factors K, μ1 and μ2 from the four S parameters (*K FACTOR*, *μ1 FACTOR*, *μ2 FACTOR*).

Notes:

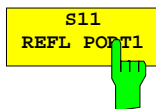
- The system-error correction can only be applied to the measurement of S parameters and quantities derived from them such as Z and Y parameters
- If S-parameters and wave quantities or ratios are measured at the same time, the display channels cannot be coupled (the SWEEP SWEEP - COUPLED CHANNELS softkey is switched off).
- Ratios of measured waves (e.g. S parameters) and quantities derived from them are also allowed in the frequency-converting modes (SYSTEM MODE - FREQUENCY CONVERTS). However, if frequency conversion is actually set, the results will be spurious unless the two waves are converted to the same receive frequency. This is because the ZVx network analyzer family's measurement and reference channels can only be set to a single common receive frequency. If, however, a phase difference between waves is to be measured at different frequencies, external frequency conversion is required (see sections 2.4.1.3 and 2.4.1.6).

In some operating modes (selected with the *MODE* key), the number of selectable measured quantities is reduced.

- The wave a_2 or ratios which are functions of this wave can only be selected when models in the ZVR and ZVC families are in internal mode.
- During the SOI or TOI measurement (SYSTEM MODE - COMPRESS SOI TOI), only wave quantities b_1 or b_2 (WAVE QUANTITY - b_1 or WAVE QUANTITY - b_2) can be measured.

2.14.1.1 Measurement of S-Parameters

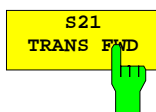
RESPONSE MEAS menu:



The *S11 REFL PORT1* softkey selects the input reflection coefficient S_{11} as measured quantity.

S_{11} is measured at PORT 1 and defined as the ratio of the wave amplitudes b_1 and a_1 . This ratio is also the default setting for S_{11} in the *USER DEFINED S-PARAMETERS* table.

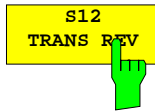
For the external reflection measurement, a device for separating the forward and the reflected waves must be used, e. g. a measuring bridge or a directional coupler. On the instruments of the ZVR and ZVC families, for example, the input of the measuring bridge must be connected to OUTPUT a_1 , and its output to INPUT b_1 for the preset definition of S_{11} .



The *S21 TRANS FWD* softkey selects the forward transmission coefficient S_{21} as measured quantity.

S_{21} is measured as transmission from PORT 1 to PORT 2 and is defined as the ratio of the wave amplitudes b_2 and a_1 . This ratio is also the default setting for S_{21} in the *USER DEFINED S-PARAMETERS* table.

For this setting, the input of the DUT must be connected to OUTPUT a_1 , and its output to INPUT b_2 or PORT 2 (model ZVRL) in the external mode in the instruments of the ZVR and ZVC families.



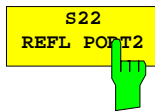
The *S12 TRANS REV* softkey selects the reverse transmission coefficient S_{12} as measured quantity.

S_{12} is measured as transmission from PORT 2 to PORT 1 and is defined as the ratio of the wave amplitudes b_1 and a_2 .

Only for the ZVR and ZVC families: In the external mode, S_{12} is particularly useful if another transmission coefficient is to be measured at the same time as S_{21} . For this reason, S_{12} is predefined as the ratio of waves b_1 and a_1 in the *USER DEFINED S-PARAMETERS* table.

In this case, the input of the DUT must be connected to OUTPUT a1, and its output to INPUT b1.

The softkey *S12 REV TRANS* is not provided on the model ZVRL.



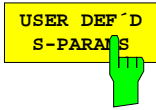
The *S22 REFL PORT2* softkey selects the output reflection coefficient of the DUT S_{22} as measured quantity.

S_{22} is measured at PORT 2 and is defined as the ratio of the wave amplitudes b_2 and a_2 .

Only for the ZVR and ZVC families: In the external mode, S_{22} is particularly useful if another reflection coefficient is to be measured at the same time as S_{11} . For this reason, S_{22} is predefined as the ratio of waves b_2 and a_1 in the *USER DEFINED S-PARAMETERS* table.

For an external reflection measurement, a device for separating the forward and the reflected waves must be used, e. g. a measuring bridge or a directional coupler. If the basic assignment of S_{22} is set, the input of the measuring bridge must be connected to OUTPUT a1, and its output to INPUT b2.

The *S22 REFL PORT2* softkey is not provided on the model ZVRL.



The *USER DEF'D S-PARAMS* softkey opens the table *USER DEFINED S PARAMETERS*. This table is used to re-define S-parameters, thus allowing them to be adapted to an external test setup.

The main application of user-defined S-parameters is the unidirectional measurement of two independent transmission or reflection parameters at the same time. In the case of bidirectional full two-port error correction, however, a re-definition of S-parameters is not useful and its outcome is difficult to predict. For this reason, user-defined S-parameters cause switching to unidirectional measurement in the forward direction for the whole unit. With models of the ZVR and ZVC family, this condition is fulfilled by coupling user-defined S-parameters to "External measurements" mode (option ZVR-B25).

| DEFINE S-PARAMETERS | | |
|---------------------|-----------|------------------|
| S-PARAM | NUMERATOR | DENOMINATOR |
| S11 | ✓ b1 | ✓ a1 b1 b2 |
| | b2 | |
| S21 | b1 | |
| | ✓ b2 | |
| S12 | ✓ b1 | |
| | b2 | |
| S22 | b1 | |
| | ✓ b2 | |

The table *USER DEFINED S-PARAMETERS* contains the S- parameters to be defined and also two editable columns:

S-PARAM – S-Parameters

NUMERATOR – Numerator with which the S-parameter is formed

DENOMINATOR – Denominator with which the S-parameter is formed

The current setting is marked by a tick and is active for the measurement.

Notes:

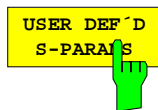
- The wave quantity a2 (incident wave at the DUT in reverse direction) is not available.
- The wave quantity in the denominator is the same for all parameters.
- In the default setting, the forward parameters are defined as usual, the reverse parameters S_{12} and S_{22} , however, with the complementary wave quantity (eg b1 instead of b2) in the numerator for the corresponding forward parameter.

This default setting allows the independent parallel measurement of two reflection or transmission parameters. If the definition of a currently measured S-parameter deviates from the usual one used in internal operation, the parameter is added USER in the info line.

The settings of table *USER DEFINED S-PARAMETERS* have no effect on the internal operation.

The parameters S12 and S22 are omitted in the table with ZVRL.

If the same wave quantity is selected for numerator and denominator, the constant value 1 is obtained irrespective of the measurement. For the availability of a calibration, it is checked if the user-defined S-parameters are useful, ie if numerator and denominator differ. For unidirectional two-port calibration, the numerators of the two S-parameters to be corrected should also differ.



(ZVK and ZVM only)

The definition table can be called again by means of the softkey *USER DEF'D S-PARAMS* in the submenu with the same name. This may be useful, for instance, if the table was deleted inadvertently by pressing the CLR key.



(ZVK and ZVM only)

The softkey *USER DEF ACTIVE* activates the user-defined S-parameters in the table *USER DEF'D S-PARAMS* for the whole unit. In contrast to units of the ZVR and ZVC family, ZVK and ZVM do not activate the user-defined S-parameters automatically when switching on external operation but only if *USER DEF ACTIVE* is pressed. If this softkey is pressed, the unit automatically switches to unidirectional measurement in the forward direction. This means that wave quantity a_2 and all quotients formed with it are no longer available as magnitudes. When switching *USER DEF ACTIVE* on or off, a measurement is output as to which S-parameter definition is active.

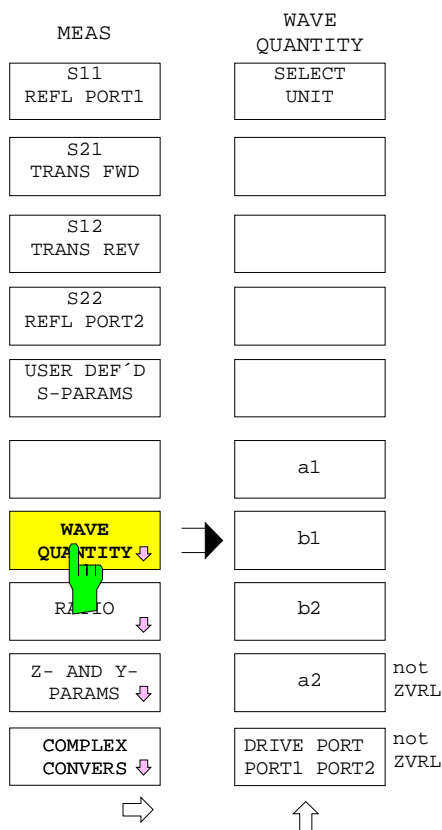
2.14.1.2 Measuring Wave Quantities

The *WAVE QUANTITY* softkey calls a submenu that allows receiver input signals to be selected directly as measured quantities, i.e. without any prior formation of quotients.

The input signals are referred to as waves a1, b1, b2, a2 in the *WAVE QUANTITY* submenu. Their assignment to the physical connectors of the unit is different for the internal and the external mode.

- In the internal mode, the index of the wave quantity (1 or 2) determines whether the instrument measures at PORT 1 or PORT 2.
- Only for the ZVR and ZVC families: In the external mode, the assignment can be seen from the labeling of the connector (OUTPUT a1, INPUT b1 and INPUT b2). The wave a₂ cannot be measured in external mode.
- If the power correction is switched off (*CAL - POWER UNCAL* is on) all measured levels refer to the assigned connector. An exception is the reference mixer mode (*SYSTEM MODE - REFERENCE MIXER* on): In this case, the rear panel connector IF REF serves as the reference plane for the measured level of a₁. The output level, however, still refers to PORT1 or OUTPUT a1.

RESPONSE MEAS - WAVE QUANTITY submenu:



In the *RESPONSE MEAS – WAVE QUANTITY* submenu,

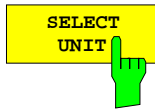
- the physical unit of the measured quantity can be selected (*SELECT UNIT*),
- a wave quantity (a1, b1, b2, a2) can be selected for measurement,
- in the internal mode, the generator signal is fed either to measurement PORT 1 or PORT 2 (*DRIVE PORT PORT 1 / PORT 2*). This function is not available on ZVRL.

Power calibration should first be performed if attenuation is active in the signal path between the instrument connector and the actual measurement port or if stringent demands are placed on measurement accuracy. System error correction is not possible in wave quantity measurements.

Note:

- Only unconverted wave quantities can be measured. Conversion is therefore switched off automatically. In addition, switchover is made to *MAGNITUDE*, which is the only permissible format, and a Cartesian diagram is selected as a default setting.

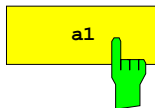
If wave a₁ or a₂ is selected and this does not agree with the active status of *DRIVE PORT PORT 1/PORT 2*, the source port is switched over and a message is output.



The *SELECT UNIT* softkey calls the table of the same name, where physical units for single waves can be defined.

The units *W* and *V* can be selected for a linear trace in a linear grid or for a logarithmic trace in a logarithmic grid (*RESPONSE DIAGRAM - LIN CARTESIAN* and *LOG CARTESIAN*). If a logarithmic trace is represented in a linear dB-grid (*dB CARTESIAN*), the options are dBm, dBW, dB μ V and dBV. The default settings are *W* and dBm, respectively.

| SELECT UNIT | SELECT UNIT |
|-------------|-------------|
| ✓ W | ✓ dBm |
| V | dBW |
| | dB μ V |
| | dBmV |
| | dBV |

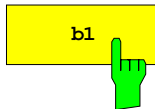


The *a1* softkey selects the wave amplitude a_1 as measured quantity.

In the internal mode, this is the outgoing wave at PORT 1. In the external mode, it is the outgoing wave at OUTPUT a1.

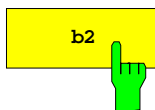
Notes:

- *ZVR and ZVC families: In the REFERENCE MIXER mode (only with option ZVR-B6), the rear-panel connector a1 EXT IN is used as the measurement input for wave a1. If a1 is to be measured in the frequency-converting mode (SYSTEM MODE - FREQUENCY CONVERTERS), the generator signal, which is available at connector a1 EXT OUT, for example, must be externally converted to the receive frequency. The factory-set receive power correction for a1 always refers to PORT 1 or OUTPUT a1. There is no special receive power correction for the REFERENCE MIXER mode.*
- *ZVM and ZVK: The signal path of wave a1 can be disconnected between connectors R1 CHANNEL OUT / IN to insert a reference mixer, for example.*



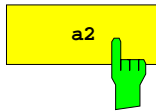
The *b1* softkey selects the wave amplitude b_1 as measured quantity.

In the internal mode, this is the incoming wave at PORT 1. In the external mode, it is the incoming wave at INPUT b1.



The *b2* softkey selects the wave amplitude b_2 as measured quantity.

In the internal mode, this is the incoming wave at PORT 2. In the external mode, it is the incoming wave at INPUT b2. In the case of ZVRL, b_2 is measured at PORT 2 in both the internal and the external mode.

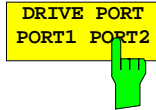


The *a2* softkey selects the wave amplitude a_2 as measured quantity.

This is the outgoing wave at PORT 2.

The *a2* softkey is not provided on ZVRL. In the case of the ZVR and ZVC families, it is operative only in the internal mode.

Note: On ZVM and ZVK, the signal path can be disconnected between connectors *R2 CHANNEL OUT / IN* to insert a reference mixer, for example.



The *DRIVE PORT PORT1/PORT2* softkey sets the signal-path switch of the test set.

This softkey is not provided on ZVRL. In the case of the ZVR and ZVC families, it is not operative in the external mode. It is coupled with the softkeys of the same name in the right side menu of the *MEAS* key and in the *RATIO* menu.

2.14.1.3 Measuring Ratios of Wave Quantities

RESPONSE MEAS - RATIO Submenu:

| MEAS | RATIO |
|------------------------|---|
| S11 REFL PORT1 | DEFINE RATIO |
| S21 TRANS FWD | CONV GAIN b1/Pa1 |
| S12 TRANS REV | CONV GAIN b2/Pa1 |
| S22 REFL PORT2 | b1/a1 |
| USER DEF'D S-PARAMS | b2/a1 |
| | b1/a2 <small>not ZVRL</small> |
| WAVE QUANTITY ↓ | b2/a2 <small>not ZVRL</small> |
| RATIO ↓ | b1/b2 |
| Z- AND Y- PARAMS ↓ | b2/b1 |
| COMPLEX CONVERS ↓ | DRIVE PORT <small>not ZVRL</small> PORT1 PORT2 |

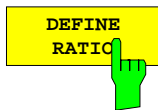
The **RATIO** softkey opens a submenu that selects ratios of the wave amplitudes received by the network analyzer as measured quantities.

For a description which wave amplitudes are available see below the **DEFINE RATIO** softkey. The assignment of the waves to the physical sockets of the instruments depends on the measuring mode and is described in the **MEAS - WAVE QUANTITY** submenu.

- The ratios are defined in a table (**DEFINE RATIO**).
- The most important ratios can be directly called via softkeys (**CONV GAIN** b_x/Pa_1 , b_1/a_1 , ... b_2/b_1) in the **RATIO** menu.
- In the internal mode, the generator signal is fed either to the measurement port PORT 1 or PORT 2 (**DRIVE PORT PORT1/PORT2**). This function is not available on the ZVRL.

Note:

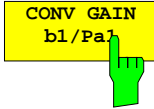
- Only unconverted ratios can be measured. Conversion is therefore switched off automatically. In addition, switchover is made to the **MAGNITUDE** format, and a Cartesian diagram is selected as a default setting.
- If a ratio with denominator a_1 or a_2 is selected and this does not agree with the active status of **DRIVE PORT PORT 1 / PORT 2**, the source port is switched over and a message is output.
- For the measurement of waves a_1 and a_2 using a reference mixer, refer to the description of the **MEAS - WAVE QUANTITY -a₁ / a₂** softkeys.



The **DEFINE RATIO** softkey calls the table **DEFINE RATIO**, where the numerator (NUMERATOR) and the denominator (DENOMINATOR) of a dimensionless ratio can be defined.

Both the numerator and the denominator may be one of wave quantities a_1 , b_1 or b_2 , which are determined by vector measurement. The quantity a_2 is available on all models except ZVRL. In the case of the ZVR and ZVC families, a_2 is permissible only in the internal mode. In cases where a_1 and a_2 cannot be measured because the generator frequency differs from the receive frequency (**SYSTEM MODE - FREQUENCY CONVERS**), the nominal and possibly level-corrected power of the Pa_1 generator signal is available, in the internal mode also Pa_2 (not on ZVRL). Powers Pa_1 and Pa_2 are used for calculating the conversion gain (**CONV GAIN** b_1/Pa_1).

| DEFINE RATIO | | |
|--------------|-------------|----------|
| NUMERATOR | DENOMINATOR | |
| a1 | a1 | |
| ✓ b1 | b1 | |
| b2 | ✓ b2 | |
| a2 | a2 | not ZVRL |
| a1 | a1 | |
| a2 | a2 | not ZVRL |

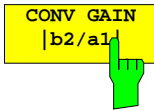


The *CONV GAIN b1/Pa1* softkey displays the conversion gain for the wave b1.

In frequency-converting measurements, S parameters are not defined. Since the receiver is usually set to the frequency converted by the DUT and, as a result, the reference signal cannot be measured at the input frequency of the DUT, the conversion gain used instead is the ratio of the measured receive signal (here the wave b₁) and the nominal generator signal power (here the level of the wave a₁).

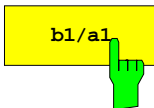
Notes:

- As the measured phase of the numerator is random, only the magnitude formats (*FORMAT - MAGNITUDE* and *FORMAT - SWR*) are possible for this quantity.
- *CONV GAIN b1/Pa1* corresponds to the (uncorrected) reflection coefficient at connector PORT 1.
- Only ZVR and ZVC families: In the external mode, the transmission is measured from OUTPUT a1 to INPUT b1.

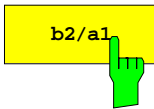


The *CONV GAIN b2/Pa1* softkey displays the conversion gain for the wave b2.

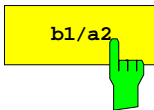
This quantity is defined analogous to the conversion gain *CONV GAIN b1/Pa1* (see above). In the internal mode, the transmission from PORT 1 to PORT 2 is measured, in the external mode, that of OUTPUT to INPUT 2 or OUTPUT to PORT 2 (ZVRL).



The *b1/a1* softkey selects the ratio of the wave amplitudes b₁ and a₁ as measured quantity.

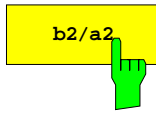


The *b2/a1* softkey selects the ratio of the wave amplitudes b₂ and a₁ as measured quantity.



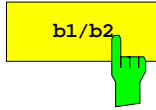
The *b1/a2* softkey selects the ratio of the wave amplitudes b₁ and a₂ as measured quantity.

This softkey is not available on ZVRL. In the case of the ZVR and ZVC families, it is not operative in the external mode.

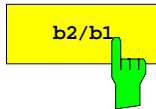


The b_2/a_2 softkey selects the ratio of the wave amplitudes b_2 and a_2 as measured quantity.

This softkey is not available on ZVRL. In the case of the ZVR and ZVC families, it is not operative in the external mode.



The b_1/b_2 softkey selects the ratio of the wave amplitudes b_1 and b_2 as measured quantity.



The b_2/b_1 softkey selects the ratio of the wave amplitudes b_2 and b_1 as measured quantity.

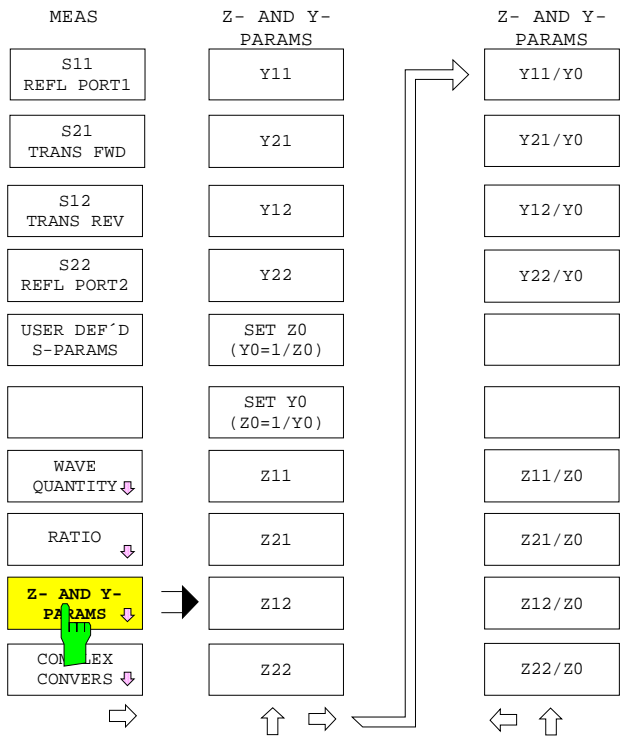


The *DRIVE PORT PORT1/PORT2* switches the signal-path of the test set.

This softkey is not available on ZVRL. In the case of the ZVR and ZVC families, it is not operative in the external mode. It is coupled with the softkeys of the same name in the right side menu of the *MEAS* key and in the *WAVE QUANTITY* menu.

2.14.1.4 Measurement of Two-Port Z or Y Parameters

RESPONSE MEAS – Z- AND Y-PARAMS submenu:



The Z AND YPARAMS softkey opens a submenu for measuring two-port Z or Y parameters.

- The two-port Z or Y parameters can be measured absolutely, i.e. using the units Ω or S.
- The parameters normalized to reference impedance Z_0 or reference admittance Y_0 can also be selected.
- Reference impedance Z_0 or reference admittance Y_0 can be entered. The reference impedance of the system-error calibration performed previously, or loaded by means of RECALL, is preset.

The measurement of the two-port Z or Y parameters is based on the transformation of the two-port scattering matrix into an impedance or admittance matrix. Any Z or Y parameter is, therefore, a function of the four S parameters (system-error corrected, if necessary).

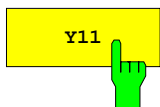
If a Z or Y parameter is selected as a parameter, a polar diagram is set and markers are formatted as LIN MAG AND PHASE.

Two-port Z and Y parameters that are not normalized can be stored in file formats *.s2p or *.flp (see section 2.6.2.3).

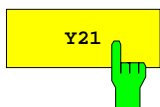
Notes:

If a two-port Z or Y parameter is selected as measurement quantity, the following settings cannot be selected:

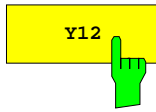
- Time domain measurement mode (SYSTEM MODE – TIME DOMAIN)
- Complex conversion (RESPONSE MEAS – COMPLEX CONVERS)
- SWR and group delay formats (RESPONSE FORMAT – SWR, GROUP DELAY, STEP APERTURE, FREQUENCY APERTURE)
- Marker conversion (MARKER MARKER – MARKER CONVERS)
- Certain marker formats (MARKER MARKER – MARKER FORMAT), the choice of selectable formats depending on whether the current Z or Y parameter is normalized or not.



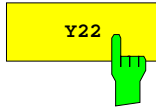
The Y11 softkey selects the input admittance Y_{11} as a parameter.



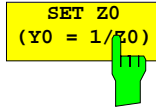
The Y21 softkey selects the forward transadmittance Y_{21} as a parameter.



The Y12 softkey selects the reverse transadmittance Y_{12} as a parameter.



The Y22 softkey selects the output admittance Y_{22} as a parameter.

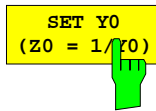


The SET Z0 ($Y_0 = 1/Z_0$) softkey activates the entry for reference impedance Z_0 .

Reference impedance Z_0 is required to calculate two-port Z and Y parameters from S parameters. Its reciprocal is the reference admittance Y_0 (see SET Y0 ($Z_0=1/Y_0$) softkey). Furthermore, Z_0 is used to convert a single S parameter into an impedance or admittance (see section 2.14.1.5). The corrections for receiver-power calibration also involve Z_0 (see section 2.15.1.4.1) as does the absolute level of a wave quantity.

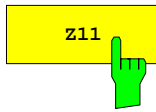
If a system-error calibration is performed, or system-error corrections are loaded, Z_0 is overwritten with the calibration reference impedance.

The default value of the input field depends on the characteristic impedance of the model; it is therefore either 50 Ω or 75 Ω .

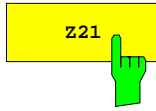


The SET Y0 ($Z_0 = 1/Y_0$) softkey activates the input for reference admittance Y_0 .

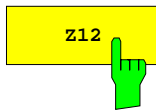
Reference admittance Y_0 is the reciprocal of reference impedance Z_0 (see SET Z0 ($Y_0=1/Z_0$) softkey).



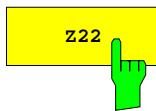
The Z11 softkey selects input impedance Z_{11} as a measured quantity.



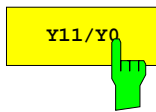
The Z21 softkey selects the forward transimpedance Z_{21} as a measured quantity.



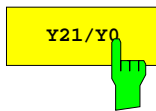
The Z12 softkey selects the reverse transimpedance Z_{12} as a measured quantity.



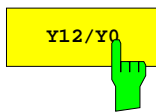
The Z22 softkey selects output impedance Z_{22} as a measured quantity.



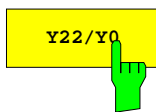
The Y11/Y0 softkey selects the normalized input admittance Y_{11}/Y_0 as a measured quantity.



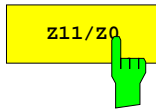
The Y21/Y0 softkey selects the normalized forward input admittance Y_{21}/Y_0 as a measured quantity.



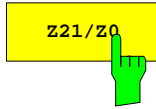
The Y12/Y0 softkey selects the normalized reverse input admittance Y_{12}/Y_0 as a measured quantity.



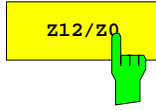
The Y22/Y0 softkey selects normalized output admittance Y_{22}/Y_0 as a parameter.



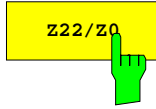
The Z_{11}/Z_0 softkey selects the normalized input impedance Z_{11}/Z_0 as a measured quantity.



The Z_{21}/Z_0 softkey selects the normalized forward transimpedance Z_{21}/Z_0 as a measured quantity.



The Z_{12}/Z_0 softkey selects the normalized reverse transimpedance Z_{12}/Z_0 as a measured quantity.



The Z_{22}/Z_0 softkey selects the normalized output impedance Z_{22}/Z_0 as a measured quantity.

2.14.1.5 Converting the Measured Quantity

Conversion means that an S parameter is converted into another complex quantity. It must not be mistaken for formatting, where a complex quantity is mapped to a scalar one.

RESPONSE MEAS - COMPLEX CONVERTS Submenu:

| MEAS | COMPLEX CONVERTS |
|------------------------|-----------------------|
| S11 REFL PORT1 | S |
| S21 TRANS FWD | 1/S |
| S12 TRANS REV | |
| S22 REFL PORT2 | |
| USER DEF'D S-PARAMS | |
| | SET Z0 (Y0 = 1/Z0) |
| INPUT ↓ | Y/Y0 |
| RATIO ↓ | Y |
| | Z/Z0 |
| COMPLEX CONVERTS ↓ | Z |

The *COMPLEX CONVERTS* opens the submenu for selecting the conversion of the measured quantity.

Conversion is always applied to S parameters:

- The reciprocal value can be formed (1/S),
- with a specified reference impedance Z_0 (*SET Z0 (Y0=1/Z0)*), absolute and normalized impedances (Z/Z_0 , Z) can be calculated.
- with a specified reference admittance Y_0 (*SET Z0 (Y0=1/Z0)*), absolute and normalized admittances (Y/Y_0 , Y) can be calculated.

What kind of formula is used to convert an S-parameter into impedances or admittances depends on whether a reflection parameter (S_{11} or S_{22}) or a transmission parameter (S_{12} or S_{21}) is to be converted.

Reflection parameters are converted to terminating impedances or admittances:

$$Z = Z_0 \frac{1 + S_{ii}}{1 - S_{ii}}, Y = \frac{1}{Z}$$

where S_{ij} is the reflection parameter and Z_0 the reference impedance.

Transmission parameters are converted to serial impedances or admittances:

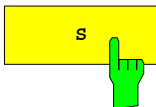
$$Z = Z_0 \frac{2(1 - S_{ij})}{S_{ij}}, Y = \frac{1}{Z}$$

where S_{ij} is the transmission parameter and Z_0 the reference impedance.

The following applies to normalized quantities:

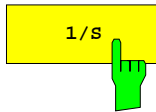
$$z = \frac{Z}{Z_0}, y = \frac{Y}{Y_0} = Z_0 Y$$

When the conversion type is changed (except for switchover from S to 1/S and vice versa), formatting and diagram type are set to default values. The marker conversion is changed analogously.



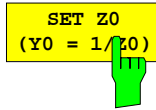
The S softkey does not convert the S-parameter and is the default setting.

When S is selected, the *FORMAT - MAGNITUDE* formatting with associated default diagram is set.



The $1/S$ softkey inverts the selected S parameter.

This is useful in stability measurements, for example. When $1/S$ is selected, the *FORMAT - MAGNITUDE* formatting with associated default diagram is set.

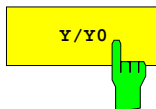


The *SET Z0* ($Y_0 = 1/Z_0$) softkey activates the entry of a reference impedance Z_0 .

Reference impedance Z_0 is required to calculate a single S parameter from S parameters. Its reciprocal is the reference admittance Y_0 . Furthermore, Z_0 is used to convert a single S parameter into an impedance or admittance (see section 2.14.1.4). The corrections for receiver-power calibration also involve Z_0 (see section 2.15.1.4.1) as does the absolute level of a wave quantity.

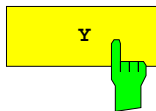
If a system-error calibration is performed, or system-error corrections, are loaded, Z_0 is overwritten with the calibration reference impedance.

The default value of the input field is $50\ \Omega$ or $75\ \Omega$, depending on the characteristic impedance of the instrument.



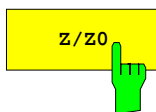
The *Y/Y0* softkey converts the selected S parameter into a normalized admittance.

The *COMPLEX* formatting and a polar diagram with a radius of 2,5 are set at the same time.



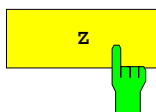
The *Y* softkey converts the selected S parameter into an admittance. The reference impedance defined under *SET Z0* ($Y_0 = 1/Z_0$) is used.

The *COMPLEX* formatting and a polar diagram with a radius of 50 mS are set.



The *Z/Z0* softkey converts the selected S parameter into a normalised impedance.

The *COMPLEX* formatting and a polar diagram with a radius of 2,5 are set.



The *Z* softkey converts the selected S parameter into an impedance. The reference impedance defined under *SET Z0* ($Y_0 = 1/Z_0$) is used.

The *COMPLEX* formatting and a polar diagram with a radius of $125\ \Omega$ are set.

2.14.1.6 Measurement of Stability Factors

Three parameters are available to assess the stability of linear two-ports such as amplifiers. They are derived by conversion from the S parameters of the DUT and are represented as a function of frequency or of another stimulus quantity. These are the parameters K factor, μ_1 factor and μ_2 factor which are defined as follows [References: Marion Lee Edwards and Jeffrey H. Sinsky "A New Criterion for Linear 2-Port Stability Using a Single Geometrically Derived Parameter", IEEE Trans. MTT, vol. 40, No. 12, pp. 2303-2311, Dec. 1992]:

$$K := \frac{1 - (|S_{11}|)^2 - (|S_{22}|)^2 + (|S_{11} \cdot S_{22} - S_{12} \cdot S_{21}|)^2}{2 \cdot |S_{12} \cdot S_{21}|}$$

$$\mu_1 := \frac{1 - (|S_{11}|)^2}{|S_{22} - \overline{S_{11}} \cdot (S_{11} \cdot S_{22} - S_{12} \cdot S_{21})| + |S_{21} \cdot S_{12}|}$$

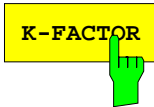
$$\mu_2 := \frac{1 - (|S_{22}|)^2}{|S_{11} - \overline{S_{22}} \cdot (S_{11} \cdot S_{22} - S_{12} \cdot S_{21})| + |S_{21} \cdot S_{12}|}$$

where S_{11} is the complex conjugate of S_{11} , i.e. $S_{11} := x \cdot j y$ if $S_{11} := x \cdot j y$, where $j = \sqrt{-1}$.

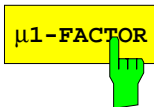
The two-port under test is stable when the stability factor is greater than 1. Values less than 1 indicate instability and are shown in colour in the measurement curve.

Note: Stability factors are scalar quantities carrying a sign. Consequently, only the REAL format can be selected. A Cartesian diagram with linear or logarithmic y axis is displayed.

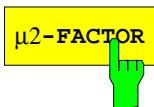
RESPONSE MEAS – side menu:



Softkey *K-FACTOR* converts the measured S parameters of the DUT into stability factor K.



Softkey μ_1 -FACTOR converts the measured S parameters of the DUT into stability factor μ_1 .



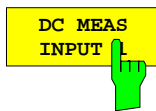
Softkey μ_2 -FACTOR converts the measured S parameters of the DUT into stability factor μ_2 .

2.14.1.7 Measuring DC Voltage

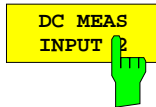
The DC MEAS INPUTS group on the rear of the instrument comprises BNC connectors DC 1 and DC 2. These are floating inputs for measuring DC voltages between –10 V and +10 V. The measuring diagram displays the voltage versus the selected sweep variable (frequency, time, generator power). In addition, power added efficiency (PAE) can be calculated.

Notes:

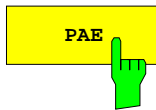
- In DC voltage measurements, the same A/D converters are used as for RF signals. For this reason, DC voltages or PAE cannot be measured together with other quantities with coupled display channels. Coupled channels are, therefore, automatically decoupled when a DC voltage is selected, and a message is output.
- Voltages and power added efficiency are scalar quantities carrying a sign. So, only the REAL format can be selected. A Cartesian diagram with linear or logarithmic y axis is displayed.



The DC MEAS INPUT 1 softkey selects the voltage present at the DC 1 input as measured quantity.



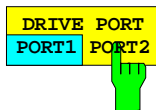
The DC MEAS INPUT 2 softkey selects the voltage present at the DC 2 input as measured quantity.



The PAE softkey selects the power added efficiency of an active two-port as measured quantity. The power added efficiency is defined as the ratio of the added power generated by the two-port to the power delivered by the power supply. So, the added RF power is the difference between the power generated by port 2 and the power supplied to port 1. The two power values can be expressed by the squared magnitudes of the associated wave quantities by the following formula:

$$PAE = \frac{|b_2|^2 - |a_1|^2}{P_{DC}}$$

The supply power P_{DC} is measured via the DC 1 voltage input. It is assumed that a linear relationship exists between P_{DC} and the measured voltage, the proportionality constant being 1 W/V.



The DRIVE PORT PORT1/PORT2 softkey switches the signal path in the test set.

This softkey is not provided on ZVRL. In the case of the ZVR and ZVC families, it is not operative in the external mode. It is coupled with the softkeys of the same name in the menus WAVE QUANTITY and RATIO.

2.14.2 Formatting of the Measured Quantity – *FORMAT* Key

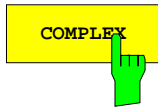
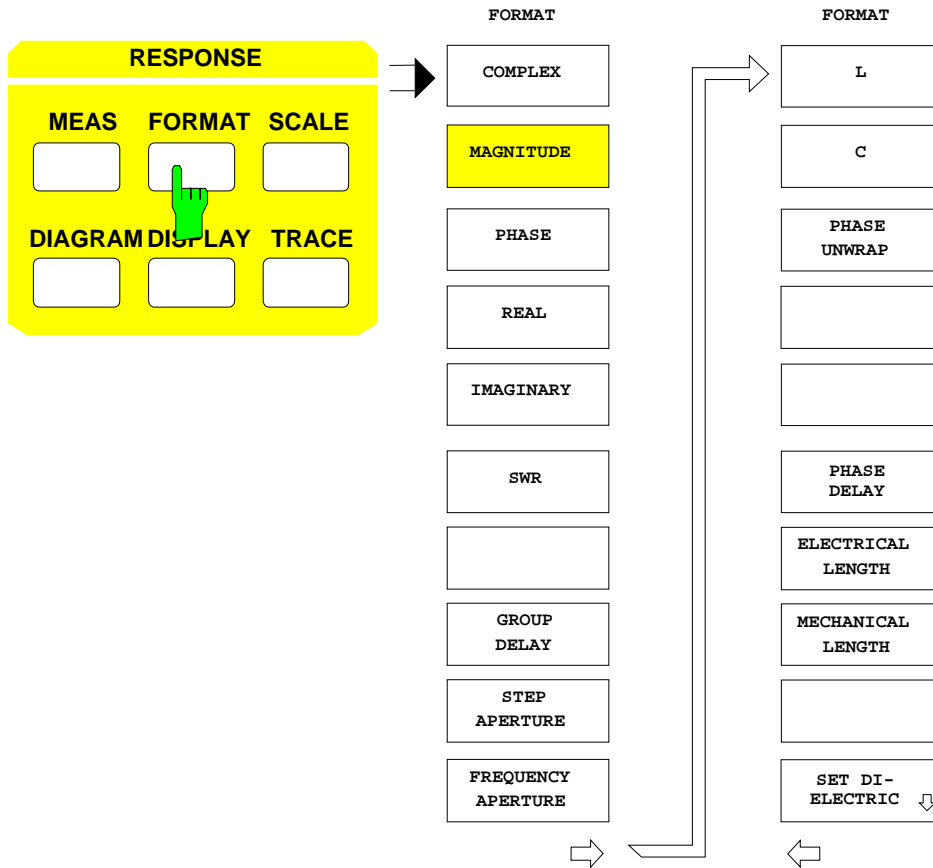
The *FORMAT* key opens a menu which defines in which form the complex measured quantity selected with the *MEAS* key is displayed.

- A complex quantity can be directly represented in a circular diagram (*COMPLEX*).
- A complex quantity can be converted into a scalar quantity and then represented in a Cartesian diagram. As is common for complex quantities, they can be represented by their magnitude and phase (*MAGNITUDE, PHASE*), or by their real and imaginary parts (*REAL, IMAGINARY*).
- The standing wave ratio (*SWR*) can be calculated from the reflection coefficients.
- The group delay (*GROUP DELAY*) can be calculated from the phase and frequency difference of two points (aperture). The aperture can be selected within (*STEP APERTURE*) or independent of the measured grid (*FREQUENCY APERTURE*).
- When the measured quantity is converted into an impedance (admittance), its imaginary part can be used – together with the frequency – to calculate the capacitance (inductance) which corresponds to the same reactance (susceptance) as the measured quantity (*L, C*).
- The phase can be limited to an interval or be represented continuously (*PHASE UNWRAP*).
- From the phase response of a measured quantity, the phase delay (*PHASE DELAY*), as well as the electrical and mechanical length (*ELECTRICAL LENGTH, MECHANICAL LENGTH*) can be calculated and displayed in addition.

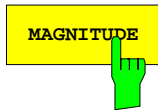
The user can enter the effective dielectric constant of a line for calculation of the mechanical length (*SET DIELECTRIC*).

Note:

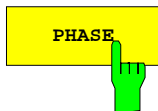
- *With a complex format, the results must be displayed in a circular diagram, with a scalar format, a Cartesian diagram must be used. When the current measured quantity is formatted, a diagram and scaling parameters suitable for typical test results are automatically selected.*
- *For direct measurements of the input signal, i. e. with one of the measured quantities of the MEAS - WAVE QUANTITY menu being selected, only the MAGNITUDE format can be used. For measurements of quotients having a scalar quantity (e.g. conversion gain), SWR may be selected in addition to MAGNITUDE.*



The *COMPLEX* softkey displays the result in a complex format. The result is displayed directly in a circular diagram.

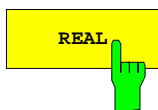


The *MAGNITUDE* softkey displays the magnitude of the current complex measured quantity in a Cartesian diagram.

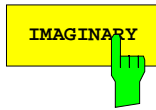


The *PHASE* softkey displays the phase of the current measured quantity in degrees. The range of values possible depends on the setting of softkey *SCALE - PHASE UNWRAP*: When the key is switched off, values between -180° and $+180^\circ$ are possible only, otherwise, the range of values is unlimited.

Note: *If the default scaling of the diagram with limits of -180° and $+180^\circ$ is selected, the wave form is represented correctly only if the difference between the phases of two adjacent test points is smaller than 180° . The *PHASE* format cannot be selected for the measurement of single wave quantities.*

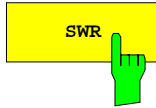


The *REAL* softkey displays the real part of the current measured quantity. The *REAL* format cannot be selected for the measurement of single wave quantities.



The *IMAGINARY* softkey displays the imaginary part of the current measured quantity.

The *IMAGINARY* format cannot be selected for the measurement of single wave quantities.

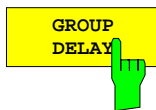


The *SWR* softkey calculates the standing wave ratio (SWR) from the measured quantity.

The *SWR* is defined for reflection parameters (S_{11}, S_{22}) and is determined from their magnitudes using the formula

$$SWR = \frac{1 + |S_{ii}|}{1 - |S_{ii}|}$$

The *SWR* format cannot be selected when single wave quantities are measured or if the conversion "admittance" or "impedance" is active.



The *GROUP DELAY* softkey calculates the group delay τ_g from the measured quantity. τ_g is defined to be the negative derivative of phase ϕ with respect to the angular velocity ω . This implies:

$$\tau_g = -\frac{d\phi}{360^\circ df}$$

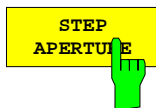
where $d\phi$ is the phase variation in degrees over the frequency increment df , which is also referred to as aperture. The aperture most favorable for a specific measurement task must be set by the user in each case according to the phase characteristics, the greatest phase slope in the sweep range under test being decisive for the selection of the aperture. If the latter is too great, detail information will be lost, if it is too small, the effect of measurement noise will be too strong.

The aperture can be defined in two ways:

- by specifying a number of test points within the grid (*STEP APERTURE*),
- by defining a fixed frequency value (*FREQUENCY APERTURE*, see below). This will however double the number of test points.

According to its definition, a group delay can only be measured in the frequency sweep mode (*SYSTEM MODE – SWEEP MODE – FREQUENCY SWEEP*).

In the frequency-converting mode (*SYSTEM MODE - FREQUENCY CONVERTS*), only a relative measurement of the group delay related to a reference mixer is possible (see section 2.4.1.6).

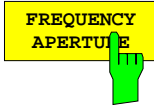


The *STEP APERTURE* softkey activates the entry of the aperture width for group delay measurements as a number of test points in the grid. The default setting for group delay measurements is *STEP APERTURE* with an aperture of 10 test points.

Only integers ≥ 1 are permitted. Entering *STEP APERTURE* = 5, for example, will result in the phase values of test points $n-3$ and $n+2$ to be used for calculating the group delay at test point n .

Since no measurements are made outside the set sweep range, the aperture is reduced to about half of its value at the limits of the range. In the above example, the value obtained at the first sweep point would be determined from the phases of points 1 and 3.

Contrary to group delay measurements with a constant aperture (*FREQUENCY APERTURE*), *STEP APERTURE* does not require a higher number of test points than other formats. However, the aperture width varying with respect to frequency in the case of non-equidistant test points may have a negative effect. *STEP APERTURE* has no function for single-point measurements (*SWEEP SWEEP - SINGLE POINT*).



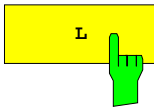
The *FREQUENCY APERTURE* softkey activates the entry of the aperture for group delay measurements as a continuously adjustable frequency value f_{aperture} .

As compared to the entry via *STEP APERTURE*, the number of test points is doubled, since for each point f_{test} of the sweep range two phase measurements are performed, i. e. at $f_{\text{test}} - f_{\text{aperture}}/2$ and at $f_{\text{test}} + f_{\text{aperture}}/2$. The higher accuracy is thus achieved at the expense of a longer sweep time.

If a system error correction is to be made in a group delay measurement with *FREQUENCY APERTURE*, and if the associated calibration was not performed with the test point grid of the set group delay measurement, the correction data must be interpolated (and, if the case may be, extrapolated at the limits of the sweep range). If required, the *CAL CAL - INTERPOL* softkey is automatically activated and a message is displayed. This also occurs when the current calibration was performed during an active group delay measurement (with *FREQUENCY APERTURE* on) which is then switched off.

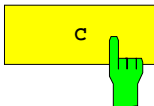
When group delay measurements with frequency aperture are performed, the display channels are de-coupled (the *SWEEP SWEEP - COUPLED CHANNELS* softkey is switched off).

The frequency aperture is not available in connection with an active gate in the time domain (*TIME GATE*) of option ZVR-B2.



The softkeys *L* and *C* calculate an inductance or capacitance that corresponds to the imaginary part of the measured impedance or admittance at the measured frequency.

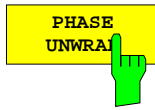
To this end, the measured value must be converted into an impedance or admittance (*RESPONSE MEAS - COMPLEX CONVERS* submenu). The values for *L* and *C* can then be calculated taking into account the measurement frequency f :



$$L = \frac{\text{Imag}(Z)}{2\pi f} \qquad C = -\frac{1}{\text{Imag}(Z)2\pi f}$$

$$L = -\frac{1}{\text{Imag}(Y)2\pi f} \qquad C = \frac{\text{Imag}(Y)}{2\pi f}$$

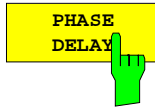
If the assumed equivalent circuit reflects real conditions, the values of *L* or *C* do not depend on the frequency.



The *PHASE UNWRAP* softkey cancels the limitation of the range to $\pm 180^\circ$ in the scalar phase representation (*PHASE* softkey is on).

No more steps will occur and the phase may assume any value. However, at the start of the sweep, the phase value will always be between $+180^\circ$ and -180° .

The scaling of the diagram will not be changed by switching over *PHASE UNWRAP*.



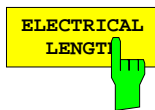
The *PHASE DELAY* softkey calculates the phase delay τ_ϕ and displays its value in the marker-info field (entry PD:).

The representation of the test trace is not changed. The phase delay is calculated according to the formula

$$\tau_\phi = -\frac{\Delta\phi}{360^\circ \Delta f}$$

$\Delta\phi$ designates the entire phase span over the sweep range Δf . However, same as with *PHASE*, a correct result will be achieved only if the phase difference between two adjacent test points does not exceed 180° .

The format *PHASE DELAY* is not available if a complex conversion is active (*RESPONSE MEAS - COMPLEX CONVERS*) or Z or Y parameters are represented (*RESPONSE MEAS - Z- AND Y-PARAMS*).



The *ELECTRICAL LENGTH* softkey calculates the electrical length $l_{el\phi}$ of the DUT and displays it in the marker-info field (entry EL:).

The electrical length is calculated from the phase delay τ_ϕ (see softkey *PHASE DELAY*) using the formula

$$l_{el\phi} = c_0 \tau_\phi$$

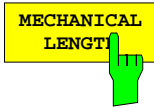
where c_0 stands for the velocity of light in a vacuum.

The format *ELECTRICAL LENGTH* is not available if a complex conversion is active (*RESPONSE MEAS - COMPLEX CONVERS*) or Z or Y parameters are represented (*RESPONSE MEAS - Z- AND Y-PARAMS*).

Note:

According to its definition, the electrical length is given by the product of velocity of light and the differential group delay τ_g (see above). The group delay is replaced by the phase delay for two reasons:

- *Specifying the electrical length is useful only for non-dispersive DUTs in which the phase and group delay coincide.*
- *Measurement accuracy for phase delay is by far higher than for group delay as for phase delay the aperture is considerably wider.*



The *MECHANICAL LENGTH* softkey calculates the mechanical length l_{el0} of the DUT and displays it in the marker-info field (entry ML:).

MECHANICAL LENGTH differs from *ELECTRICAL LENGTH* only in that not the vacuum light velocity is assumed for electromagnetic wave propagation but a lower speed, the latter resulting from the use of a dielectric:

$$l_{\text{mech}\phi} = c_0 \frac{1}{\sqrt{\epsilon_r}} \tau_\phi$$

This is useful especially if a cable dielectric is to be taken into account.

With the aid of table *SET DIELECTRIC*, the required relative dielectric constant ϵ_r , or alternatively the reduction factor for the wave velocity (*VELOCITY FACTOR*), can be specified.

The format *MECHANICAL LENGTH* is not available if a complex conversion is active (*RESPONSE MEAS - COMPLEX CONVERTS*) or Z or Y parameters are represented (*RESPONSE MEAS - Z- AND Y-PARAMS*).

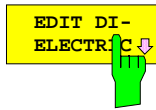


The *SET DIELECTRIC* softkey activates a table of the same name for selecting the relative dielectric constant ϵ_r (*EPSILON*) or the reduction factor for the wave velocity (*VELOCITY FACT*), which are used in calculating the mechanical length of a DUT.

The quantities dielectric constant and reduction factor are equivalent, see table *EDIT DIELECTRIC* below.

The table *SET DIELECTRIC* is identical with the one used for defining an offset of the measurement plane in the menu belonging to the *OFFSET* key. The dielectric selected is the same in both cases, too.

| SET DIELECTRIC | | |
|--------------------|---------|---------------|
| DIELECTRIC | EPSILON | VELOCITY FACT |
| ✓ AIR | 1.00056 | 0.999720 |
| POLYETHYLENE | 2.5 | 0.63 |
| TEFLON | 2.1 | 0.69 |
| MICROPOROUS TEFLON | 1.5 | 0.82 |
| USER DEFINED | 1 | 1 |
| USER DEFINED | 1 | 1 |
| USER DEFINED | 1 | 1 |
| USER DEFINED | 1 | 1 |



The *EDIT DIELECTRIC* softkey calls the *EDIT DIELECTRIC* table that is superimposed on table *SET DIELECTRIC* and is used for editing the name and parameters of the selected dielectric.

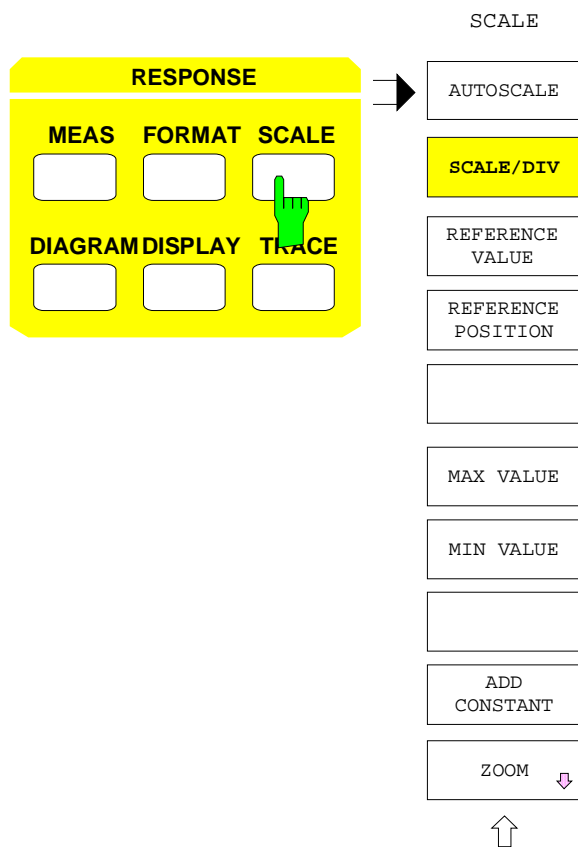
The following relationship exists between the second and the third column:

$$VELOCITY FACT = \frac{1}{\sqrt{EPSILON}}$$

Either of the two fields can be edited. The other field will be adjusted automatically.

| EDIT DIELECTRIC | | |
|-----------------|---------|---------------|
| | EPSILON | VELOCITY FACT |
| | 1 | 1 |

2.14.3 Scaling of the Test Diagram – SCALE Key



The **SCALE** key opens a menu scaling the test diagram in the active display channel.

- Scaling can be automatic or manual (**AUTOSCALE**).

In linear Cartesian or polar diagrams, there are two scaling modes:

- The fixed division by 10 or 5, where the grid increment is set with **SCALE/DIV**, the reference position with **REFERENCE POSITION** and the reference value with **REFERENCE VALUE**.
- The flexible scaling with the softkeys **MAX VALUE** and **MIN VALUE** (**MIN VALUE** not for polar diagrams), where the y-grid lines are drawn in analogy to the x-lines upon entering **START** and **STOP** values. In this case, the grid increment is automatically determined in steps of 1, 2 or 5 depending on the displayed range of values. The division lines or circles are located at absolute multiples of the grid increment. The number of division lines may vary between 5 and 15, no reference line is displayed.
- ADD CONSTANT** shifts the scaling of the axis by a specified value.
- The **ZOOM** function allows to magnify a defined section of the diagram.

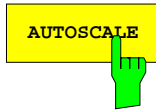
Note: *In linear polar diagrams with fixed division, the scaling and reference settings are coupled with each other since the minimum value of the radial axis is fixed at 0. If the reference value or position is changed, the grid increment is adjusted. If the grid increment is changed, the reference value is calculated anew.*

If switchover is made from fixed to flexible scaling with **MAX VALUE**, **MIN VALUE** from the previous scaling is taken over. This applies analogously to switchover made with **MIN VALUE**. If switchover is made from flexible to fixed scaling, the grid increment remains unchanged. With linear Cartesian diagrams, the reference line in the middle of the diagram is redrawn and the reference value is taken over from the division line nearest to the middle of the previous diagram. With linear polar diagrams, the outer circle of the diagram is taken as a reference circle, and the reference value is five times the value of the grid increment.

With logarithmic diagrams, only **MAX VALUE** and **MIN VALUE** can be defined. The logarithmic grid is adjusted to the specified range limits.

With Smith charts, only the radius of the outer circle can be set with **MAX VALUE**. For schematic diagrams, no scaling can be set, for diagrams with segmented y or radial axis, scaling can be set only by means of **DIAGRAM - DEF CART SEGMENTS** and **DEF POLAR SEGMENTS**.

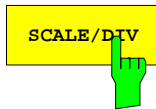
RESPONSE SCALE menu:



The *AUTOSCALE* softkey automatically re-scales the y or radial axis.

As a result, all values measured in the current sweep are really displayed on screen. The range of values is determined during the sweep run in which *AUTOSCALE* is pressed.

- In Cartesian diagrams with a linear or a linear dB-scale or in polar diagrams, *AUTOSCALE* causes 10 or 5 grid lines to be displayed and the grid increment to be defined in steps of 1, 2 or 5. In Cartesian diagrams, the reference line is positioned on a value as round as possible, in polar diagrams, on the outer circle. The reference value is a multiple of the grid increment.
- In logarithmic diagrams, the decade limits nearest to the maximum and minimum of the test trace are taken as *MAX VALUE* and *MIN VALUE*. If the difference between the maximum and minimum values is less than two octaves, the instrument automatically switches to a linear diagram and a message is displayed.
- In Smith charts, the radius of the outer circle is determined same as with linear polar diagrams.
- *AUTOSCALE* has no function in schematic or segmented diagrams.

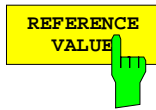


The *SCALE/DIV* softkey activates the entry of the grid increment for the y or radial axis.

If flexible axis division is active, switchover is made to fixed division. The conventions set forth in the introduction to this section apply.

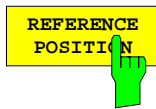
The softkey can be operated only in diagrams with a linear or a linear dB-scale or in polar diagrams.

The *SCALE/DIV* value can be defined in logarithmic steps of 1, 2 or 5 by means of the cursor keys.



The *REFERENCE VALUE* softkey activates the entry of the reference value for the scaling of the y or radial axis. If flexible axis division is active, switchover is made to fixed division. The conventions set forth in the introduction to this section apply.

The softkey can be operated only in diagrams with a linear or a linear dB-scale or in polar diagrams.

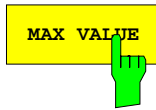


The *REFERENCE POSITION* softkey defines the position of the reference line or reference circle.

- In Cartesian diagrams, a value between 0 and 10 can be selected, with 0 corresponding to the lower and 10 to the upper edge of the diagram.
- In polar diagrams, a position between 0 and 5 can be selected, with 0 corresponding to the center and 5 to the outer circle.

Since the reference line coincides with one of the grid lines, all grid lines are shifted correspondingly. If the active diagram has flexible axis division, switchover is made to fixed division. The conventions set forth in the introduction to this section apply.

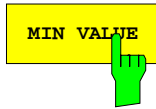
The softkey can be operated only in diagrams with a linear or a linear dB-scale or in polar diagrams.



The *MAX VALUE* softkey activates the entry of the maximum value on the y or radial axis.

If fixed axis division is active, switchover is made to flexible division. The conventions set forth in the introduction to this section apply.

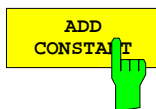
For logarithmic Cartesian diagrams (*DIAGRAM - LOG CARTESIAN* active), *MAX VALUE* must be positive. If such a diagram is split in two parts for the positive and the negative values, *MAX VALUE* defines as absolute values the maximum of the upper and the minimum of the lower half.



The *MIN VALUE* softkey activates the entry of the minimum value on the y or radial axis.

If fixed axis division is active, switchover is made to flexible division. The conventions set forth in the introduction to this section apply.

The softkey has no function with linear circular diagrams since these have a minimum value of 0. For logarithmic Cartesian diagrams (*DIAGRAM - LOG CARTESIAN* active), *MIN VALUE* must be positive. If such a diagram is split in two parts for the positive and the negative values, *MIN VALUE* defines as absolute values the minimum of the upper and the maximum of the lower half.



The *ADD CONSTANT* softkey activates the entry of a constant which is added to a scalar measured quantity or to the magnitude of a complex measured quantity.

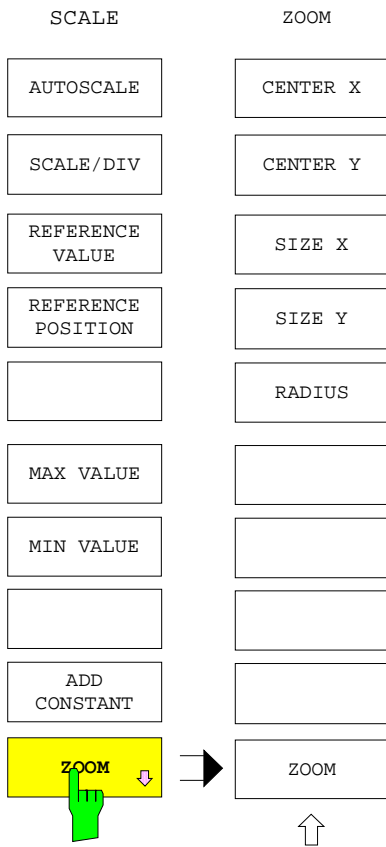
Unlike the offset quantities set with the *OFFSET* key, which refer to unconverted measured values, the value entered with *ADD CONSTANT* is added after conversion and formatting. It has the effect of a linear shift of the scaling of the y or radial axis.

In Cartesian diagrams, rectangular sections can be zoomed, in circular diagrams, round sections. The *ZOOM* menu can be called only for unsegmented diagrams. With multi-channel display, all channels can be zoomed simultaneously with different ranges of magnification.

The center and size of a section can be entered graphically or numerically. A section frame with a center cursor is displayed as a graphical aid. If no input window is open, the position can be changed by means of the cursor keys and the roll-key.

If the zoom function is activated, measurements continue to be made using the test point spacing of the unzoomed range even if only part of the points can be displayed.

RESPONSE SCALE - ZOOM Submenu:

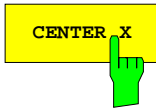


The **ZOOM** softkey opens a submenu where any segment of the test diagram in the active display channel can be magnified.

- In Cartesian diagrams, the center position (*CENTER X*, *CENTER Y*) and the width (*SIZE X*) and height (*SIZE Y*) of the frame can be selected separately.
- In circular diagrams, the radius (*RADIUS*) is set.
- **ZOOM** activates and deactivates the zoom function.
- Polar diagrams are always zoomed with reference to their origin.
- Charter diagrams cannot be zoomed.

The grid is shown with a finer or coarser structure depending on the magnifying factor. The labeling and legends within and outside the diagram, including that of the sweep and information line, are adjusted to the new grid. Since with coupled channels there is only one sweep line for all diagrams, the display mode for non-coupled channels must be selected, i.e. a sweep line appears for each diagram. The channels remain coupled, however.

When a Smith chart is zoomed, a three-line information field appears in the upper left-hand corner of the chart indicating the x and y co-ordinate of the center as well as the radius of the zoom circle. The values are output as chart co-ordinates. The *MAX VALUE* data are not displayed in the information line.



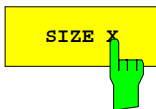
The **CENTER X** softkey activates the entry of the center co-ordinate of the zoom section frame in the X direction.

- For Cartesian diagrams, the value is entered as a percentage of the diagram width. The co-ordinate origin is in the lower left-hand corner (entry 0 to 100%).
- For circular diagrams, the value is entered as a percentage of the diagram radius. The origin is in the center (entry -100 to 100%).



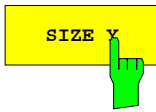
The **CENTER Y** softkey activates the entry of the center co-ordinate of the section frame in the Y direction.

For Cartesian diagrams, the value is entered as a percentage of the diagram height, for circular diagrams, as a percentage of the diagram radius. For the location of the co-ordinate origin please refer to softkey **CENTER X**.



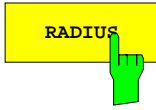
The **SIZE X** softkey activates the entry of the width of the rectangular section frame as a percentage of the diagram width.

The softkey operates only in Cartesian diagrams.



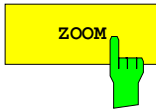
The *SIZE Y* softkey activates the entry of the height of the rectangular section frame as a percentage of the diagram height.

The softkey operates only in Cartesian diagrams.



The *RADIUS* softkey activates the entry of the radius of the circular section frame as a percentage of the diagram radius.

The softkey operates only in circular diagrams.



The *ZOOM* softkey switches the zoom function on or off.

With the zoom function switched on, the area marked by the section frame is magnified to such an extent that it takes up the whole area of the original diagram. The state of *ZOOM* is indicated by the inscription "ZOOMED" in the left, lower part of the screen.

Some operations, e. g. a change of the limits of the sweep range in Cartesian diagrams or a change of the diagram type, cause the zoom to be automatically switched off and a message to be displayed. Upon switching off the zoom function, the original representation of the test diagram is reactivated.

The zoom function cannot be switched on if logarithmic scaling is active in the x, y or radial axis and the zoom window comprises an area of less than two octaves in the respective axis.

2.14.4 Selection of the Test Diagram – *DIAGRAM* Key

The *DIAGRAM* key opens a menu where the diagram for the display of measured values can be selected.

In addition to the default diagram set automatically when the formatting for an active display channel is defined (see *FORMAT* key), a number of other diagram types is available.

If a complex measured quantity is represented as a scalar (e.g. *MAGNITUDE* formatting), *DIAGRAM* calls the main menu. The measured values can be displayed only in a Cartesian diagram. The user can select between

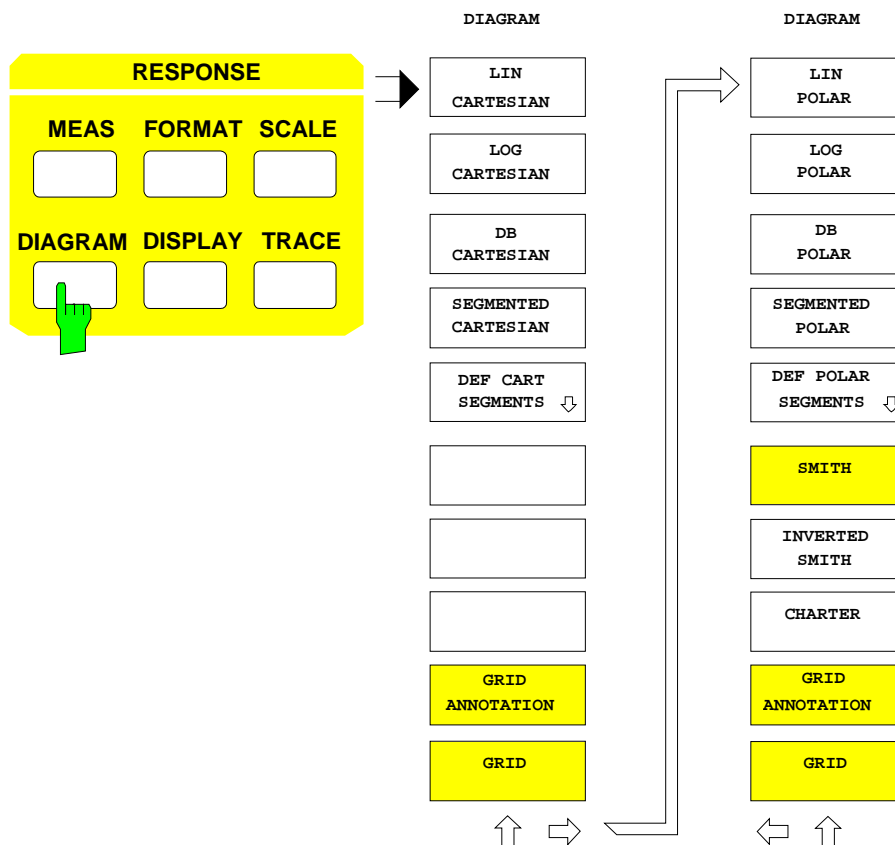
- a linear trace in a linear grid (*LIN CARTESIAN*),
- a logarithmic trace in a logarithmic grid (*LOG CARTESIAN*),
- a logarithmic trace in a linear dB grid (*DB CARTESIAN*),
- segmented scaling (*SEGMENTED CARTESIAN*), where the y axis is divided into up to three segments with different scaling (*DEF CART SEGMENTS*).

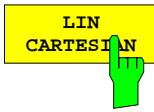
Selection of another diagram will not affect the x-axis scaling.

With complex formatting, right-hand lateral menu is called. One of the four circular diagrams, i.e.

- polar diagram, where the radial scaling may be linear (*LIN POLAR*), logarithmic (*LOG POLAR*), in dB (*DB POLAR*) or divided into a maximum of two segments (*SEGMENTED POLAR*; *DEF SEGMENTS*).
- Smith chart (*SMITH*),
- inverted Smith chart (*INVERTED SMITH*),
- or charter diagram (*CHARTER*).

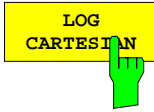
The grid for the various diagrams can be switched on or off (*GRID*). In Cartesian diagrams, the labeling (*GRID ANNOTATION*) can be switched off in addition.





The *LIN CARTESIAN* softkey displays the non-logarithmic measured quantity in a Cartesian diagram with linear y-axis division.

The number and position of the division lines depend on the selected scaling (see *SCALE* menu). *LIN CARTESIAN* can be selected only with scalar formatting.

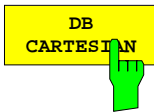


The *LOG CARTESIAN* softkey displays the logarithmic measured quantity in a Cartesian diagram with logarithmic y-axis division.

This is possible only if the y range of values comprises at least 2 octaves. If the range of values comprises between 2 octaves and 5 decades, each decade is divided in steps of 1. With more than 5 decades, a division is made in steps of 2.

The reference line is switched off with logarithmic scaling. The lower and upper limits of the range are entered using the softkeys *MIN VALUE* and *MAX VALUE*. If the selected formatting allows for negative values (e.g. *PHASE*), the logarithmic diagram is divided into two symmetrical ranges for positive and negative y values.

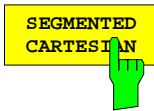
LOG CARTESIAN can be selected only with scalar formatting.



The *DB CARTESIAN* softkey displays the logarithmic trace in a diagram with linear division and dB scaling.

Similar to linear Cartesian diagrams, it is possible to activate both a fixed and a flexible scaling (see the description of the *SCALE* menu).

DB CARTESIAN is possible only in the *MAGNITUDE* format, but not with impedance or admittance (*Z* or *Y*) conversion.



The *SEGMENTED CARTESIAN* activates the division of the y-axis in segments defined by means of *DEF CART SEGMENTS*.

The segment list must not be empty or contain a segment where $MIN = MAX$. The *SCALE* key has no function in this mode. The scaling for the individual segments is defined in the *Y SEGMENTS* table.

2.14.4.1 Defining the Cartesian Segmentation of the y Axis

RESPONSE DIAGRAM - DEF CART SEGMENTS submenu:

The *DEF CART SEGMENTS* softkey opens a submenu which subdivides the y-axis of a Cartesian diagram into up to three segments.

By segmentation of the y axis, the ranges of a measured quantity that are of particular interest can be examined more closely using a scaling with a high resolution, while other ranges, in which an overview of the trace is sufficient, are shown at the same time. A typical application is the measurement of a bandpass filter, whose ripple is to be displayed with high resolution in the pass band but whose edges and stop band are of minor importance.

On the x axis of a Cartesian diagram, this corresponds to using a sweep list with the function *DIVIDED X AXIS* activated. However, unlike the divisions of the x axis, the segments of the y axis must adjoin each other, i.e. there must be no gaps and the segments must not overlap.

The x and y axes of a Cartesian diagram can be segmented at the same time (*DEF CART SEGMENTS* and *SYSTEM MODE - DEF SWEEP LIST - DIVIDED X AXIS*), yielding up to $3 \times 3 = 9$ sections with different scaling for one and the same diagram.

- The limits of the segments are defined in the *Y SEGMENTS* table. Each segment can be scaled separately. The y axis is divided into sections of equal length depending on the number of segments entered.
- All segments in a list (*DEL ALL SEGMENTS*) or a single segment (*DEL ACTIVE SEGMENT*) can be deleted
- The scaling of the segments is linear (*Y GRID LIN*), logarithmic (*Y GRID LOG*) or logarithmic with dB divisions (*Y GRID DB*). The selected scaling applies to all segments. If the formatting is changed, a new table is created. This table contains a segment whose limits correspond with the default scaling of the non-segmented display mode.

If a diagram segmented in the y-direction is active when *DEF CART SEGMENTS* is called, the instrument switches automatically to the unsegmented diagram whose grid corresponds to the grid of the segmented representation.

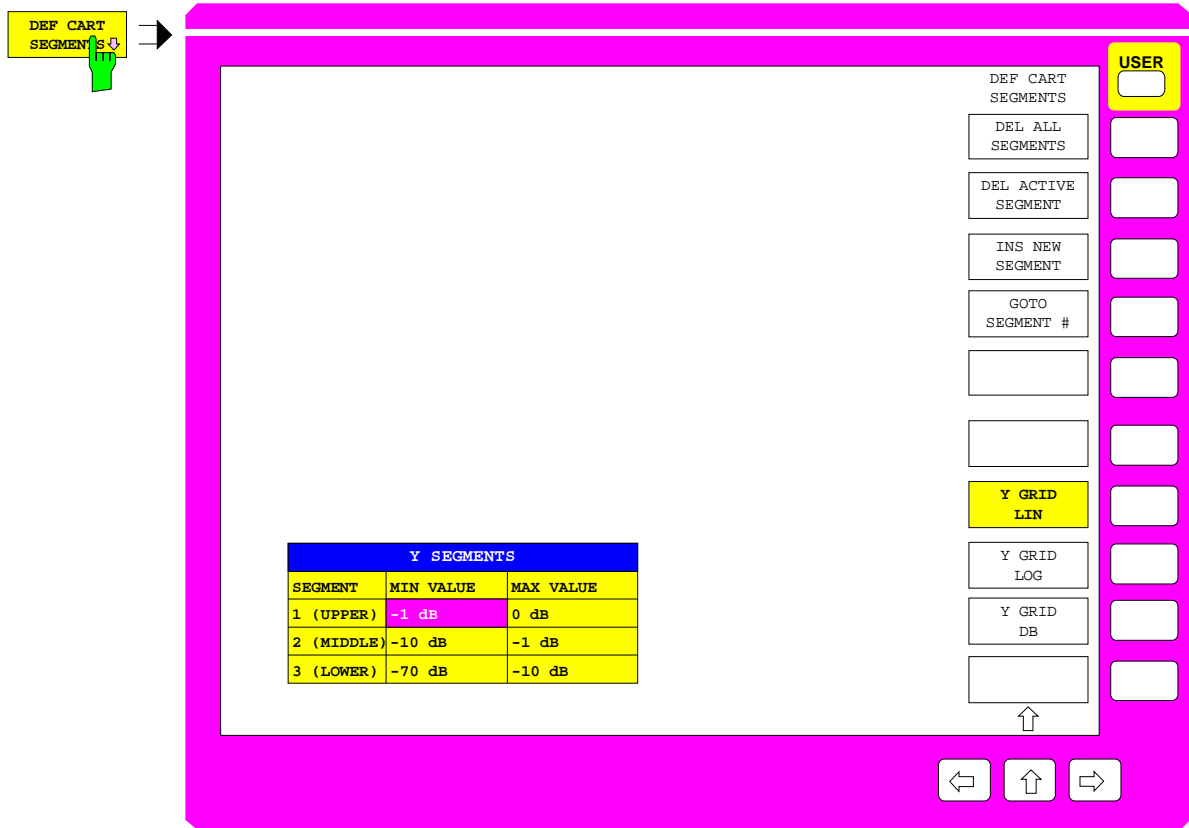


Fig. 2-36 Defining the Cartesian Segmentation of the y Axis

The Y SEGMENTS table contains, in addition to the numbering and designation of the segment in the SEGMENT column, two columns which may be edited:

SEGMENT number and designation of the segment

MIN VALUE lower limit of the segment

MAX VALUE upper limit of the segment

Note:

- As the segments adjoin each other, the limit of the adjoining segment is adjusted automatically when the limit of a segment is changed.
- If Y GRID LOG is active, it is not permissible to enter negative values.

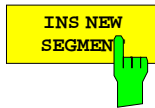
As a graphical aid, the defined segment limits are represented by means of colored continuous horizontal lines. Unlike the x-axis segments, there is no indication as to the beginnings or ends of the segments since these are adjoining. The respective designation UPPER, MIDDLE, or LOWER is displayed in each segment. The limits of the active segment are shown as dashed lines. The position of the segment limit that is currently edited is updated continuously.



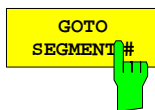
The *DEL ALL SEGMENTS* softkey deletes all segments from the table. Prior to this, a dialogue window appears that prompts the user to confirm deletion.



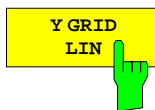
The *DEL ACTIVE SEGMENT* softkey deletes the active segment. The active segment is the segment of the line in which the editing bar is positioned.



The *INS NEW SEGMENT* softkey inserts a new segment above the active segment. The maximum number of 3 segments is however not exceeded.

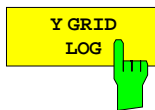


The *GOTO SEGMENT #* softkey activates the specified segment, i.e. shifts the editing bar to the corresponding line of the table.



The *Y GRID LIN* softkey selects a linear grid for the segmented y-axis. In order to make editing of the segment limits easier, the instrument switches immediately to an unsegmented, linear diagram.

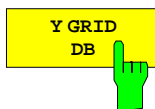
This setting applies to all segments.



The *Y GRID LOG* softkey selects a logarithmic grid for the segmented y-axis. In order to make editing of the segment limits easier, the instrument switches immediately to an unsegmented, logarithmic diagram.

The setting applies to all segments.

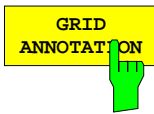
Logarithmic y-axis scaling is possible only with a positive range of values. For logarithmic scaling, the complete range of values of all segments must include at least two octaves. The switched-on state of *Y GRID LOG* is not checked for validity until y-axis scaling is activated via *SEGMENTED CARTESIAN*. Thus, the current state of this softkey can't be changed due to temporary incompatible settings of the segment list during editing.



The *Y GRID DB* softkey selects a linear grid with dB scaling for the segmented y-axis. In order to make editing of the segment limits easier, the instrument switches immediately to an unsegmented, dB-diagram.

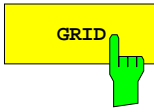
Measured values are logarithmized. The setting applies to all segments. *Y GRID DB* can be selected only with the *MAGNITUDE* format, but not if impedance or admittance (*Z* or *Y*) conversion is active.

RESPONSE DIAGRAM menu:



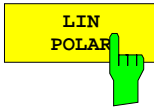
The *GRID ANNOTATION* switches the labeling in Cartesian diagrams on or off. As a default setting, the labeling is switched on.

The function is valid only for the diagram of the active display channel.



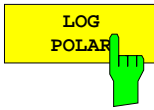
The *GRID* softkey switches on or off the grid of the diagram of the active display channel.

As a default setting, *GRID* is switched on.



The *LIN POLAR* softkey displays the non-logarithmic measured in a polar diagram with linear radial division.

The number and position of the division circles depend on the defined scaling (see *SCALE* menu). *LIN POLAR* can be selected only with complex formatting.

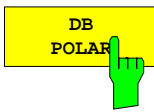


The *LOG POLAR* softkey activates a polar diagram with logarithmic radial division. The test trace is displayed in logarithmic form as well.

This is possible only if the radial range of values comprises at least 2 octaves. If the range of values comprises between 2 octaves and 2 decades, each decade is divided in steps of 1. With more than 2 decades, a division is made in steps of 2; with more than 5 decades, only the decade limits are displayed.

The reference circle is switched off with logarithmic scaling. The lower and upper limits of the range are entered using the softkeys *FORMAT - MIN VALUE* and *MAX VALUE*.

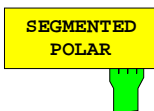
LOG POLAR can be selected only with complex formatting.



The *DB POLAR* softkey displays the logarithmic trace in a polar diagram with linear radial division in dB.

Similar to linear polar diagrams, it is possible to activate both a fixed and a flexible scaling (see *SCALE* menu).

DB POLAR can be selected only with complex formatting. The conversions impedance or admittance (*Z* or *Y*) must not be active.

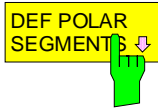


The *SEGMENTED POLAR* softkey activates the entry of the division in segments of the radial axis defined by means of *DEF POLAR SEGMENTS*.

The segment list must not be empty and contain no segment where $MIN = MAX$. In this mode the *SCALE* key is inoperative. The scaling of the individual segments results from the limits defined in table *RADIAL SEGMENTS*. The current segment limits are displayed in an info field above and to the left of the diagram.

2.14.4.2 Defining the Polar Radial Segmentation

RESPONSE DIAGRAM - DEF POLAR SEGMENTS Submenu:



The explanations given for *DEF CART SEGMENTS* in the main menu (section 2.14.1.1) apply analogously to softkey *DEF POLAR SEGMENTS* in the lateral menu, therefore no detailed description is given here.

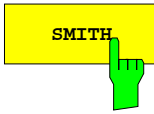
- The *RADIAL SEGMENTS* table is called instead of the *Y SEGMENTS* table,
- two radial segments can be selected instead of three,
- for linear radial scaling, the minimum value of the inner segment is always equal to 0,
- when editing the segment limits, an auxiliary circle is indicated instead of a horizontal line.



| RADIAL SEGMENTS | | |
|-----------------|-----------|-----------|
| SEGMENT | MIN VALUE | MAX VALUE |
| OUTER | 0.1 | 0.4 |
| INNER | -70 dB | -10 dB |

Fig. 2-37 Defining the Polar Radial Segmentation

RESPONSE DIAGRAM menu:



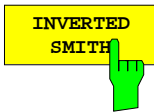
The *SMITH* softkey displays a Smith chart if complex formatting of the measured-value is active.

In this diagram type, the Cartesian grid of the complex impedance plane (*Z* plane) is projected onto the reflection-coefficient plane. Therefore it is frequently used in reflection-coefficient measurements.

The default Smith diagram is bordered by the unit circle. The user may however define the outer circle radius as required by means of *SCALE - MAX VALUE* so that a representation scaled up or down relative to the center of the circle is obtained. Moreover, the user can zoom relative to a selectable center (submenu *SCALE - ZOOM*).

The grid of these particular diagrams is made up of circle segments with prominent values, whose spacing is automatically defined as a function of the displayed range.

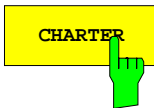
The Smith chart cannot be selected in the impedance or admittance (*Y* or *Z*) conversion.



The *INVERTED SMITH* softkey displays an inverted Smith chart if complex formatting of the measured-value is active.

An inverted Smith chart differs from the normal Smith diagram in that the admittance plane (*Y* plane) and not the impedance plane is projected onto the reflection-coefficient plane. The grid is turned 180° about the origin relative to the normal Smith diagram.

Scaling options are the same as for the normal Smith diagram. The inverted Smith diagram cannot be selected if an impedance or admittance (*Y* or *Z*) conversion is active.

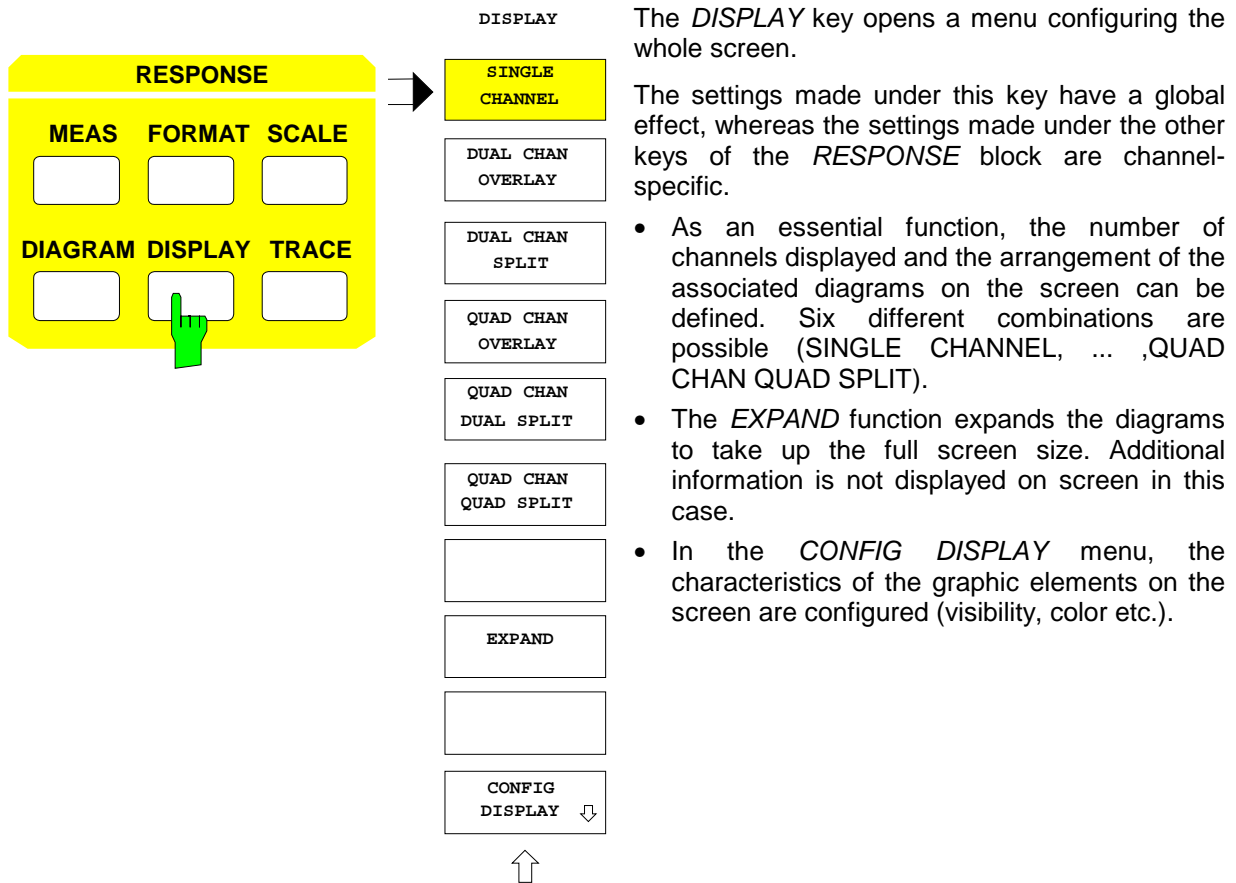


The *CHARTER* softkey displays a charter diagram if complex formatting of the measured-value is active.

Similar to the Smith chart, the charter diagram represents a projection of the complex impedance plane on the reflection-coefficient plane. However, a polar grid in the *Z* plane, i.e. a grid made up of circles of constant magnitude and radial lines of constant phase, is taken as a basis.

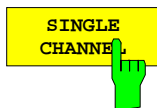
User-selected scaling or zooming is not possible with this diagram. A charter diagram cannot be selected if impedance or admittance (*Y* or *Z*) conversion is active.

2.14.5 Configuration of the Screen – *DISPLAY* Key

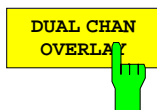


2.14.5.1 Defining the Number and Arrangement of the Display Channels

RESPONSE DISPLAY menu:

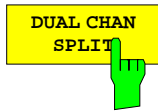


The *SINGLE CHANNEL* softkey displays the active channel alone.



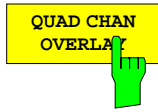
The *DUAL CHAN OVERLAY* softkey superimposes the diagrams of the active display channel and its adjacent channel.

The combinations of channel 1 and 2 or channel 3 and 4 are possible. In this combination of channels, the default assignment of S parameters to the channels is such that the forward and the reverse parameters are combined in each case. If segmented polar diagrams are displayed in overlay mode, only the info field of the active channel is displayed.



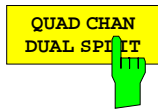
The *DUAL CHAN SPLIT* softkey superimposes the diagrams of the active display channel and its adjacent channel. It differs from *DUAL CHAN OVERLAY* only in that the diagrams of the two channels are displayed separately.

The odd-numbered channel is shown in the upper, the even-numbered channel in the lower half of the screen.



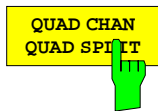
The *QUAD CHAN OVERLAY* softkey superimposes the diagrams of all four display channels.

In order to obtain a clear-cut display, the diagram type and scaling should be the same for all channels. If segmented polar diagrams are displayed in overlay mode, only the info field of the active channel is displayed.



The *QUAD CHAN DUAL SPLIT* softkey displays all four channels. In the upper half of the screen, channels 1 and 4 are superimposed on each other, in the lower half channels 2 and 3.

In this combination of channels, the default assignment of S parameters to the channels is such that the two reflection and the two transmission coefficients are combined.



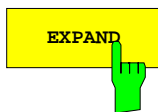
The *QUAD CHAN QUAD SPLIT* softkey displays all four channels in separate screen areas. This is the default setting.

Channel 1 is displayed in the upper left, channel 2 in the lower left, channel 3 in the upper right and channel 4 in the lower right of the screen. This has the advantage that, with the default assignment of S parameters to the channels active, the positions of the diagrams correspond to the positions of the parameters in the S matrix.

In the *QUAD CHAN QUAD SPLIT* representation, the marker field in the information line is no longer displayed. Therefore, if the marker information list is switched on, the value of the active marker is included in the list.

2.14.5.2 Expansion of Diagrams to Maximum Screen Format

RESPONSE DISPLAY menu:



The *EXPAND* softkey erases all display elements (including softkeys, enhancement labels, sweep bars, etc.) from the screen and expands the test diagram(s) to take up the maximum screen format.

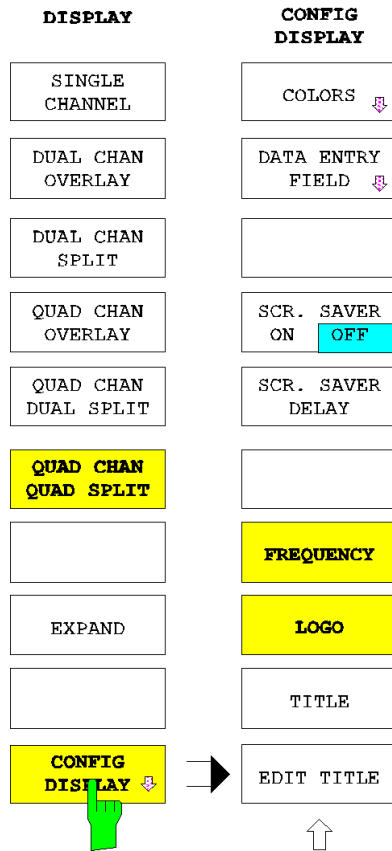
The *EXPAND* function is useful in cases where the scaling generally doesn't change and in the case of test assemblies where the trace or compliance with limit values are of interest.

In the *EXPAND* representation, the marker field in the information line is no longer displayed. Therefore, if the marker information list is switched on, the value of the active marker is included in the list.

The expanded display mode remains active until the user presses any key or clicks on any portion of the display with the mouse. The instrument then switches to the normal screen display. If a hardkey was pressed, the function triggered is executed.

2.14.5.3 Configuring the Graphic Elements of the Display

RESPONSE DISPLAY - CONFIG DISPLAY submenu



The *CONFIG DISPLAY* softkey calls a menu which sets the characteristics of the graphic elements of the display.

These include

- the colors of the graphic elements(*COLORS*),
- the position of entry fields and their display in transparent or opaque form (*DATA ENTRY FIELD*),
- the switching on and off and a delay time for the screen saver (*SCR. SAVER ON OFF*, *SCR. SAVER DELAY*)
- the insertion or removal of frequency information (*FREQUENCY*) or company logos (*LOGO*),
- the editing of diagram headings (*TITLE*, *EDIT TITLE*).

The *COLORS* softkey calls a submenu and the *DISPLAY OBJECTS* table which set the colors of the display's graphic elements.

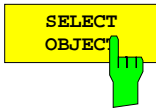
- The graphic element which is to be changed can be selected in the table *DISPLAY OBJECTS*.
- The tint, saturation and brightness of the selected graphic element (*TINT*, *SATURATION*, *BRIGHTNESS*) can be either set individually or the color can be selected from the palette offered (*SET COLORS*) In both cases, the color of the element is immediately updated.
- The default colors can be restored by means of another softkey (*RESET COLORS*).

Note: *The color assignments of the softkeys are coupled with those of other display elements. Changing for example the color of switched-off softkeys (SOFTKEY OFF) will simultaneously cause the table background color to be changed. In the same manner, SOFTKEY ACTIVE and display lines are coupled, and SOFTKEY ON and enhancement labels are coupled.*

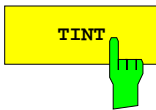


Fig. 2-38 Setting the screen colors

RESPONSE DISPLAY - CONFIG DISPLAY - COLORS submenu



The *SELECT OBJECT* softkey calls the table of the same name. In this table, the graphic element whose colors are to be changed is selected.



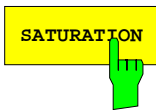
The *TINT* softkey sets the tint for the selected group.

The tint can be set between 0 and 100%, whereby 0 and 100% correspond to red and the values in between to the rest of the color spectrum.



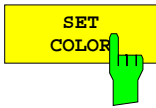
The *BRIGHTNESS* softkey sets the color brightness for the selected group..

A value between 0 and 100% can be set.



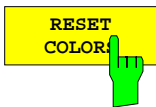
The *SATURATION* softkey sets the color saturation for the selected group.

A value between 0 and 100% can be set.



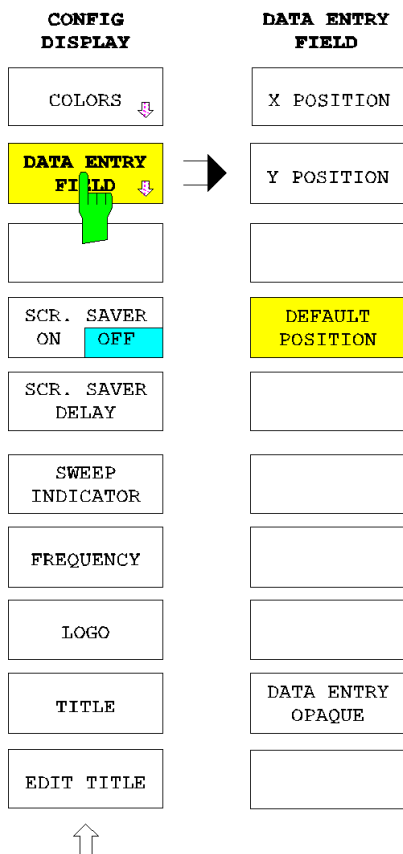
The *SET COLOR* softkey calls a table containing predefined colors which can be assigned to the graphic element selected in the *SELECT OBJECT* table.

| COLORS |
|---------------|
| BLACK |
| BLUE |
| BROWN |
| GREEN |
| CYAN |
| RED |
| MAGENTA |
| YELLOW |
| WHITE |
| DARK GRAY |
| LIGHT GRAY |
| LIGHT BLUE |
| LIGHT GREEN |
| LIGHT CYAN |
| LIGHT RED |
| LIGHT MAGENTA |

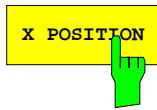


The *RESET COLORS* softkey restores the default settings of the colors. Before the current color settings are superseded, confirmation by the user is requested.

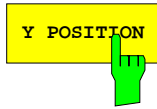
RESPONSE DISPLAY - CONFIG DISPLAY - DATA ENTRY FIELD submenu:



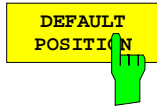
The *DATA ENTRY FIELD* softkey opens a submenu used to define the position of the selection tables and their display in opaque or transparent form.



The *X POSITION* softkey activates the entry of the x-axis position of the left edge of the selection table as a percentage of the diagram width.

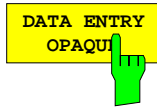


The *Y POSITION* softkey activates the entry of the y-axis position of the upper edge of the selection table as a percentage of the diagram height.



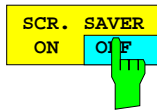
The *DEFAULT POSITION* softkey shifts the selection table to its default position, i.e.:

- *X POSITION* = 12%
- *Y POSITION* = 84,8%



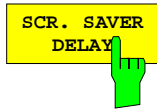
The *DATA ENTRY OPAQUE* renders the selection tables opaque. This implies that they take the same background color as the tables, and that the diagrams and traces behind are no longer visible.

RESPONSE DISPLAY - CONFIG DISPLAY submenu



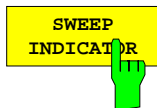
The *SCR. SAVER ON OFF* softkey switches the screen saver on or off. If the screen saver is active the back-lighting of the LCD display is switched off unless an instrument key is pressed within the delay time defined via *SCR. SAVER DELAY*.

Note: The settings made for the screen saver are not changed by *PRESET*.

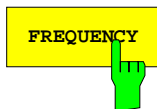


The *SCR. SAVER DELAY* softkey defines the delay time for the screen saver. The back-lighting of the LCD display is switched off unless an instrument key is pressed within the delay time. The default screen saver time is 5 min.

Note: The settings made for the screen saver are not changed by *PRESET*.

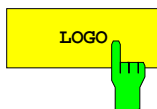


The sweep indicator can be activated or deactivated on the bottom of the measurement screen via the *SWEEP INDICATOR* softkey. The sweep indicator shows the current sweep setting and is switched on the default setting. At very short sweep times, this display flickers and may thus be disturbing.



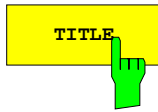
The *FREQUENCY* softkey prevents, when it is switched off, any frequency information to be displayed on the screen. In the default state, *FREQUENCY* is switched on.

The function may be used, for example, to protect confidential data.



The *LOGO* softkey switches the Rohde & Schwarz logo on and off. In the default state, the logo is switched on.

The logo is shown in the right-hand upper corner of the diagram (or, if several diagrams are displayed, in the right-hand upper diagram). It is saved in bitmap form and can be replaced by another one (see section 2.3.1).



The *TITLE* softkey switches the header line on and off, i.e. the uppermost line of the screen.

Entries into this line are made by means of *EDIT TITLE*. The line can be switched on only if it is not empty.



The *EDIT TITLE* softkey activates the input field for editing the header line.

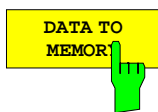
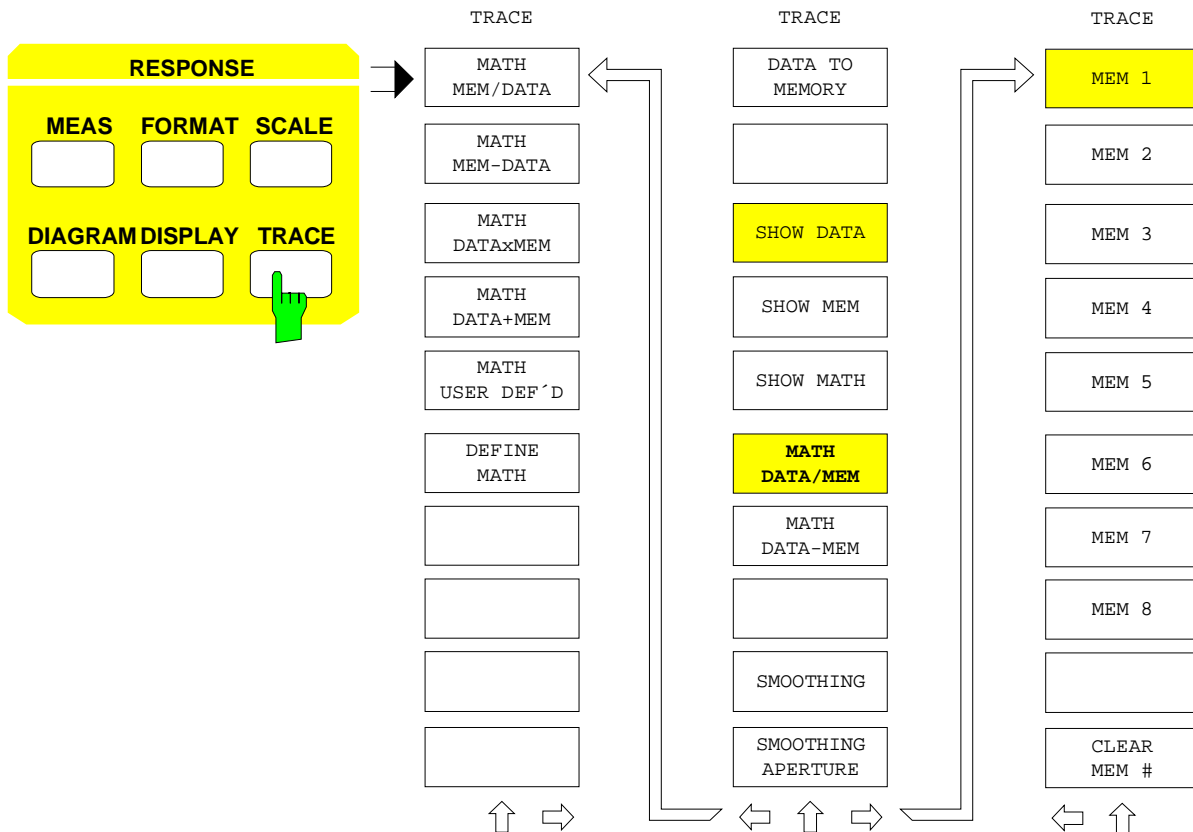
The header line is the uppermost line of the screen; it has a maximum length of 60 characters. After editing, *TITLE* is switched on automatically provided a title was entered by the user.

2.14.6 Operations with Traces – TRACE Key

The *TRACE* key opens a menu for storing and mathematically manipulating measured traces.

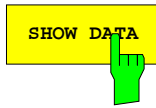
- Up to eight traces can be stored (*DATA TO MEMORY*).
- The current measured data of a channel can be displayed directly (*SHOW DATA*), mathematically linked with the data of another channel (*SHOW MATH*) or with stored data (*SHOW MEM*) before they are output.
- The mathematical relation between the current trace and stored data is defined by one of the softkeys *MATH DATA/MEM*, ... *MATH DATA+MEM* or by *MATH USER DEF'D*. In the latter case, an arbitrary mathematical relation can be entered (*DEFINE MATH*).
- The memories are selected with *MEM 1*, ... , *MEM 8* and cleared with *CLEAR MEM #*.
- A function for smoothing the current trace (*SMOOTHING*) is provided.

The assigned memory data are defined separately for each channel. Measured data are stored after error correction, i.e. prior to conversion and formatting. It is thus possible to adapt the stored trace to the current settings made with the *STIMULUS*, *SWEEP* and *RESPONSE* groups of keys.



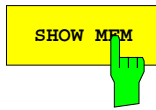
The *DATA TO MEMORY* softkey copies the data of the active display channel to the memory selected in the menu on the right.

In the default state, channels 1 to 4 are assigned memories 1 to 4. The memory content is erased by changing the sweep mode, switching off the unit or using the *CLEAR MEM #* softkey. *PRESET* does not erase the memory content.



The *SHOW DATA* softkey displays the current measured data directly, i.e. they are not linked mathematically with any other data.

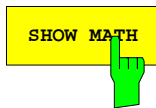
The softkey can be activated only alternatively to *SHOW MATH*, i.e. only one trace obtained from current measured data can be output per display channel.



The *SHOW MEM* softkey displays the contents of the memory selected in the right-hand menu as a static trace in addition to the current measured data, provided the memory is not empty.

Since storage of a trace is made immediately after error correction, the conversion, formatting and scaling of the trace can be adapted to match the active display channel. If the sweep range of the stored trace differs from the active sweep, stored data are indicated only for the overlapping range.

Note: *Stored data can be displayed together with the current results only if they both belong to the same category. The four categories for the measured quantities are S parameters, vectorial quotients (MEAS - RATIO menu), scalar quotients (e.g. conversion losses) and single signals (MEAS - INPUT menu).*



The *SHOW MATH* softkey links the measured data of display channels mathematically with one another or with stored data and displays them the active channel. *SHOW MATH* active is indicated by enhancement label MAT.

This is possible provided that

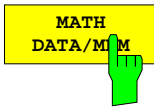
- the stimulus values of all test points of the channels or memories involved coincide,
- the measured quantities involved belong to the same category to which the active channel belongs. The four categories for the measured quantities are S parameters, vectorial quotients (*MEAS - RATIO* menu), scalar quotients (e.g. conversion losses) and single signals (*MEAS - INPUT* menu),
- the memories involved are not empty,
- the display channels involved are shown on the screen and are converted and formatted in such a way that the measured values are either all real or all complex and have the same unit. The associated memories involved are converted and formatted depending on the active display channel.

The type of mathematical relation is defined by means of a softkey (*MATH ...*). All basic arithmetic operations linking measured data of the active channel with stored data from the right-hand menu can be directly selected by means of a softkey. The default setting is *MATH DATA / MEM*.

In addition, the user can define arithmetic terms with up to three freely selectable operands (memory traces or display channels). The selected operation is in each case performed after the conversion and formatting but before a possible logarithmation. Accordingly, the mathematical relation defined in the *TRACE* menu is independent of the selected diagram type. If a dB-diagram is selected and the mathematical operation yields a negative result (e. g. after subtraction of two amplitudes), a value of -300 dB(xx) is output.

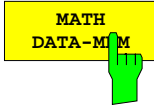
SHOW MATH can be activated only alternatively to *SHOW DATA*, i.e. only one trace obtained from current measured data can be displayed per channel.

The above-mentioned requirements must remain fulfilled after the mathematical linkage has been switched on. If for example the sweep range is changed or if the measurement mode is switched from S parameter to single signals, the measured data of the active display channel are displayed again (*SHOW DATA* is switched on) and a message is displayed.

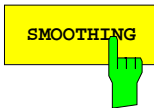


The *MATH DATA/MEM* softkey divides the current measured data by the stored data. *MATH DATA/MEM* is the default setting.

Note: *Normalization of the measured data to the stored data by is performed by MATH DATA/MEM in a logarithmic representation (e. g. a dB-representation), too.*



The *MATH DATA-MEM* softkey subtracts the stored data from the current measured data.



The *SMOOTHING* softkey smoothes the current trace over the sweep. If *SMOOTHING* is active, this is indicated by enhancement label SMO. The width of the window (*SMOOTHING APERTURE*) is indicated in the line below the label.

For smoothing a trace, local averaging is performed with reference to the sweep axis. A rectangular window symmetrical about the current test point is opened. To the left and to the right of the current test point, there is an equal number of points that are used for averaging, the points being equally weighted. The width of the window can be defined as a percentage of the sweep range by means of softkey *SMOOTHING APERTURE*. At the edges of the sweep range, the smoothing result is not so good since there are not enough points for averaging.

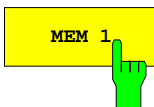
Smoothing of a trace should be applied with caution since, in the case of strong fluctuations of measured values during a sweep, the trace could be distorted. The function is mainly intended for noise bands, comparable to a video filter in spectrum analysis.

For circle diagrams, real and imaginary components are smoothed independent of each other.



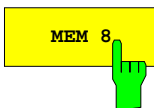
The *SMOOTHING APERTURE* softkey activates the entry of the width of the rectangular window used for smoothing.

The width is entered as a percentage of the sweep range (*STIMULUS SPAN* key). The default value is 10%, the maximum value 20%. Smoothing is not performed when the width is set to 0%.

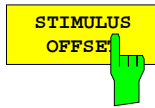


The *MEM 1* to *MEM 8* softkeys in the right-hand menu select the memory used to perform the operations *DATA TO MEM*, *SHOW MEM* and *SHOW MATH*.

...



In the default state, the four channels are assigned memories 1 to 4; any other assignments are possible.



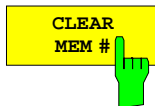
The *STIMULUS OFFSET* softkey is used to shift traces stored in memories *MEM 1* to *MEM 8* by positive or negative offsets with respect to the stimulus axis. This makes it possible to compare traces from different frequency ranges.

All sweep modes (frequency, power, time) are supported. It is possible to define an offset for each memory and also for different sweep modes when decoupling is used.

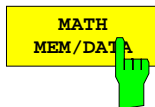
The trace can be shifted independently of the limits selected for the sweep variable. The maximum range of the sweep mode is the de-facto limit.

If a non-zero offset is defined for a memory trace, the trace can no longer be used for "trace mathematics". Conversely, no offset can be entered for data as long as the data is used for "trace mathematics".

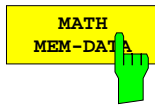
CLEAR MEM # and *DATA TO MEMORY* clear an offset defined for the memory in question.



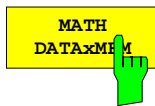
The *CLEAR MEM #* softkey clears the specified memory (no. 1 to 8).



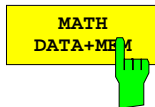
The *MATH MEM/DATA* softkey divides the memory data by the current measured data.



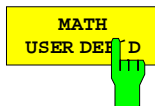
The *MATH DATA-MEM* softkey subtracts the current measured data from the memory data.



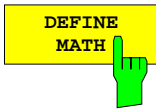
The *MATH DATAxMEM* softkey multiplies the current measured data with the memory data.



The *MATH DATA+MEM* softkey adds the memory data to the current measured data.



The *MATH USER DEF* softkey selects the mathematical operation linking max. three operands which is defined by means of table *DEFINE MATH*.



The *DEFINE MATH* softkey calls a table of the same name. The table allows to define a mathematical term consisting of max. three operands linked by means of basic arithmetic operations. The mathematical operation defined by means of a softkey is preset (eg $MATH = DATA/MEM$).

The first operand is always the active display channel. The two other operands are either display channels or memories and should be compatible with the active display channel (see *SHOW MATH* softkey). The single-line table *DEFINE MATH* shows the currently defined mathematical expression:

| DEFINE MATH | | | |
|-------------|---|--------|------------|
| (DATA CH3 | / | MEM 3) | - DATA CH1 |

In evaluating this term, the 1st and the 2nd operand are linked first, then the third operand is linked. In other words, the position of the parentheses cannot be changed.

The selection bar can be placed on each of the five column fields unless *FINISHED* is selected for one of the operators (see below). In this case, the bar can be moved only from the first operand to the operator field in question.

When one of the operand fields is edited, the table *OPERAND X* is superimposed (X stands for the number of the operand):

| OPERAND 1 |
|-----------|
| DATA CH1 |
| DATA CH2 |
| DATA CH3 |
| DATA CH4 |
| MEM 1 |
| MEM 2 |
| MEM 3 |
| MEM 4 |
| MEM 5 |
| MEM 6 |
| MEM 7 |
| MEM 8 |

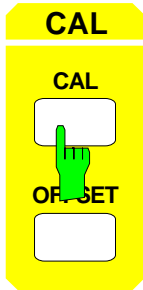
This table contains only operands that fulfill the compatibility conditions for the *SHOW MATH* softkey (refer to this softkey). The active display channel is preset. Only this channel can be selected for the first operand field.

While editing an operator in table *DEFINE MATH*, the table *OPERATOR X* is displayed (X stands for the number of the operator):

| OPERATOR 1 |
|------------|
| + |
| - |
| x |
| / |
| FINISHED |

If *FINISHED* is selected, the term is reduced to the part left of the operator field in question, i.e. the term includes only one or two operands.

2.15 Correction of System Errors – CAL Key Group



The *CAL* key group comprises the keys *CAL* and *OFFSET* and is used to correct systematic errors.

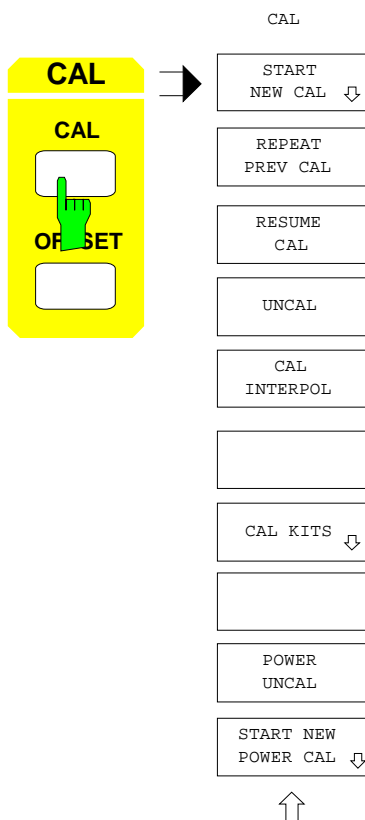
- The *CAL* key allows to determine and correct system errors.
- The *OFFSET* key allows to enter known offset values for system error correction.

2.15.1 Calibration – CAL Key

The *CAL* key opens a menu to determine and correct systematic, i.e., reproducible errors of the network analyzer. There are two types of them:

- **System errors**, caused by, e. g., directivity, mismatch at the test port and transmission loss, impair the measurement of S-parameters. System errors can be represented by a linear signal flowchart.
- **Level errors** can occur due to deviation of the generator level from the nominal value or faulty measurement of the receive level. They impair measured quantities which are determined by absolute level measurements, such as compression and intercept points.

When the display channels are coupled (*COUPLED CHANNELS* softkey is switched on) during a system error or power correction, one single correction data set applies for all channels together. If that softkey is switched off, the correction data are channel-specific, the *CAL* key menu only affecting the active channel.



The following functions are provided in the *CAL* menu:

- performing a system-error calibration with entry of all additional information required (*START NEW CAL*),
- repeating the last-performed system-error calibration without any entry, i.e., directly calling the corresponding standard test menu (*REPEAT PREV CAL*),
- continuing an aborted system-error calibration (*RESUME CAL*),
- switching on and off the system error correction (*UNCAL*),
- switching on and off the interpolation (*CAL INTERPOL*), if the test points of the current sweep range are located within a calibrated range,
- modifying or entering the calibration standard characteristics (*MODIFY CAL KIT*),
- switching on and off the power correction (*POWER UNCAL*),
- performing a power calibration (*START NEW POWER CAL*).

2.15.1.1 System Error Calibration

The first six softkeys of the *CAL CAL* menu (*START NEW CAL, ... , MODIFY CAL KIT*) perform a system error calibration. The enhancement label *CAL* indicates that the system-error correction is switched on. If the correction values are interpolated. If the correction values are interpolated over the sweep variable, the *CAI* label is displayed. The label *CA?* (calibration questionable) is displayed if the generator power has changed during calibration.

A system error correction can only be applied to the measurement of S-parameters. This is why a system error calibration cannot be performed in frequency-converting operating modes, with measurement of intercept points and with selective power measurement.

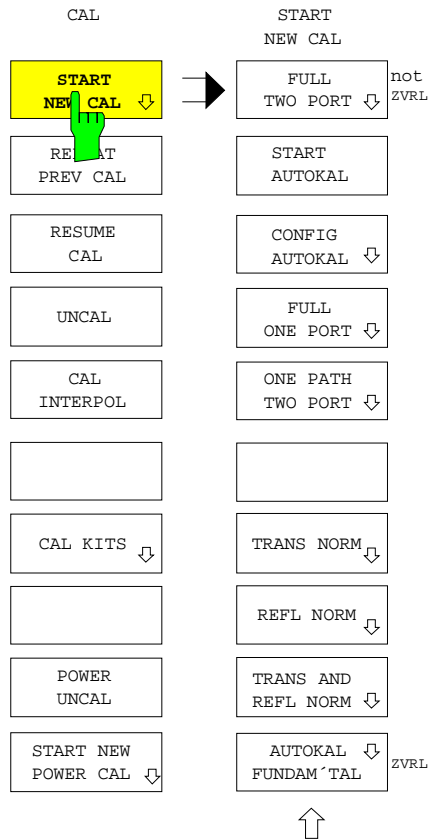
The system-error correction is switched off for measuring modes and parameters which are not compatible with it. This applies to the following cases:

- Switching over between internal and external mode, newly defining S-parameters in external mode, switching on or off the reference mixer mode, activating the frequency conversion or a non-linear measurement or changing the sweep mode cause.
- Switching on the selective power measurement or modification of an attenuation.
- Inadequate location of the test points on the frequency axis, so that interpolation is not possible or not allowed.
- Selection of a test parameter which can not be corrected by means of the current data.

Calibration data is recorded for each frequency point of the sweep range. When a group delay measurement with frequency aperture is performed, please note that the test point grid and thus the grid of the calibration's interpolation points deviates from the usual grid used with other formatting modes.

2.15.1.1.1 Performing a System-Error Calibration

CAL-CAL START NEW CAL submenu:



The *START NEW CAL* softkey starts the system-error calibration. The softkey calls a chain of submenus which leads back to the main menu of the CAL key after a completed calibration.

First, the calibration mode is selected i. e.

- a complete calibration for one or two-port measurements (*FULL ONE PORT, FULL TWO PORT*),
- an automatic calibration (*AUTOKAL*),
- a unidirectional two-port calibration (*ONE PATH TWO PORT*) or
- a simple normalization (*TRANS NORM; REFL NORM; TRANS AND REFL NORM*).

This selection already determines the calibration procedure to be used. Only for the full two-port calibration, the calibration procedure is selected in an additional menu.

After selecting the calibration mode, menus are called for those calibration modes which require information on the calibration standards used. The menus offer selection of the multipoint-connector family and polarity of the test ports, thus enabling access to the parameters of the associated calibration set which can be edited via the *MODIFY CAL KIT* menu. Since these multipoint-connector selection menus are identical for all calibration procedures they are explained in the following as well as the general way of measuring a calibration standard.

Apart from the coaxial connector families N (50 Ω and 75 Ω), SMA, PC7 and PC 3.5 which are normally used in the frequency range up to 8 GHz, two user-defined types of connector are offered, the reference impedance of which can be freely selected. The parameters of the associated calibration standards can be entered via the tables called by entering *CAL - MODIFY CAL KIT - SELECT OTHER KIT - USER KIT 1* or *USER KIT 2*. Calibrations for exceptional connector families or for planar transmission lines can be performed this way.

Subsequent to selection of a softkey in the connector selection menu it is checked whether the parameters of the standards selected for the calibration are valid in the current frequency range. The latter must not exceed the range between MIN FREQ and MAX FREQ of the standard list (see *MODIFY CAL KIT* softkey). Otherwise, a warning is displayed.

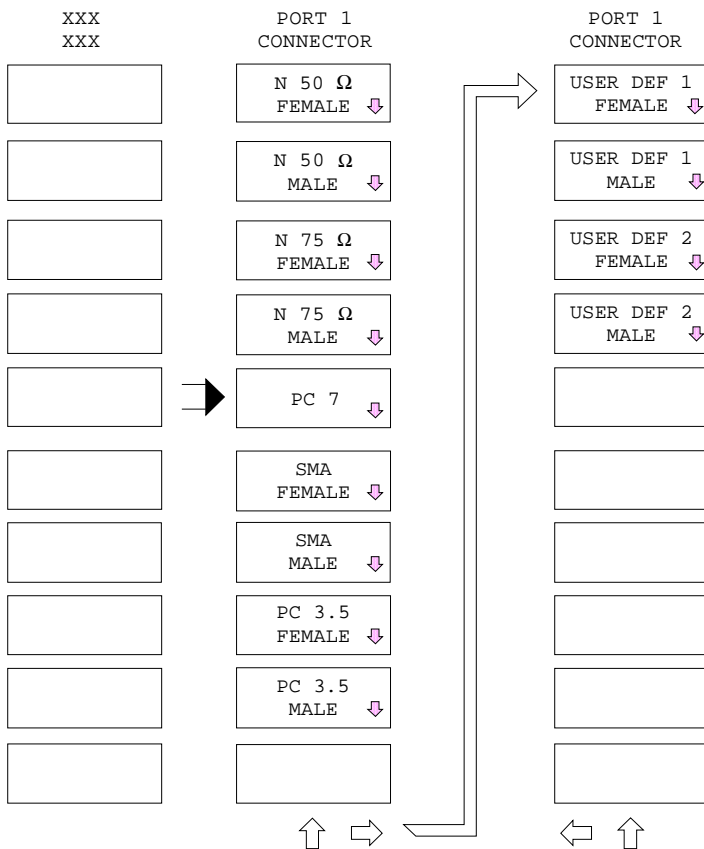
a) Specification of the Connectors at the Test Ports

The *PORT 1 CONNECTOR* menu is called if the calibration procedure selected requires the characteristics of the standards connected to test port 1 to be known. This applies to the full two-port calibration, the full one-port calibration at port 1 and at both ports as well as for the unidirectional calibration in forward direction.

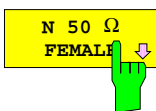
In the internal operating mode, test port 1 need not coincide with the socket PORT 1 but may be located, e.g., at the end of a cable connected to PORT 1. In the external mode, which allows for redefinition of S-parameters, test port 1 is characterized as follows: in its reference level, the incident wave of the S_{11} denominator is fed to the DUT and the wave of the numerator is reflected.

If the selected calibration requires no further information regarding test port 2, the menu for measuring the calibration standard (from hereon called the "calibration test menu") is called immediately upon selection of the connector of test port 1. Otherwise, the *PORT 2 CONNECTOR* menu is displayed.

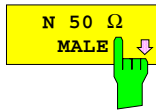
CAL CAL - START NEW CAL - XXX - PORT 1 CONNECTOR submenu
(for ZVR and ZVC with N 50 Ω test ports):



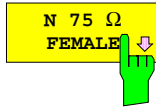
The type and order of the connectors shown in this menu are different for the different models of the ZVx family. The connector types used for the instrument test ports always come at the uppermost position.



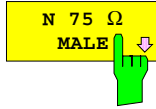
The *N 50 Ω FEMALE* softkey declares the test port to be a socket of the connector family N 50 Ω.



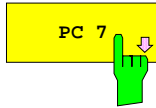
The *N 50 Ω MALE* softkey declares the test port to be a connector of the connector family N 50 Ω.



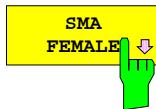
The *N 75 Ω FEMALE* softkey declares the test port to be a socket of the connector family N 75 Ω.



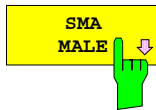
The *N 75 Ω MALE* softkey declares the test port to be a connector of the connector family N 75 Ω.



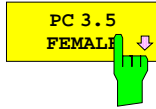
The *PC 7* softkey declares the test port to be a connector of the balanced connector family PC 7.



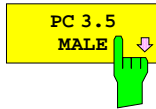
The *SMA FEMALE* softkey declares the test port to be a socket of the connector family SMA.



The *SMA MALE* softkey declares the test port to be a connector of the connector family SMA.



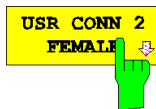
The *PC 3.5 FEMALE* softkey declares the test port to be a socket of the connector family PC 3.5.



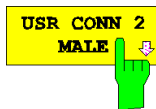
The *PC 3.5 MALE* softkey declares the test port to be a connector of the connector family PC 3.5.



The *SEXLESS USR CONN 1* softkey declares the test port to be a connector of the sexless user-definable connector family 1. This family is particularly suitable for transitions in planar conductor structures



The *USR CONN 2 FEMALE* softkey declares the test port to be a socket of the user-definable connector family 2.



The *USR CONN 2 MALE* softkey declares the test port to be a connector of the user-definable connector family 2.

The *PORT 2 CONNECTOR* menu, which is not available on ZVRL, is analogous to the *PORT 1 CONNECTOR* menu. This menu is called if the properties of the standard connected to test port 2 are needed for the calibration mode selected.

- For a full two-port calibration, the connector families at the two ports must be the same, i. e. the choice in the *PORT 2 CONNECTOR* menu is limited to connector and socket of the family selected for *PORT 1 CONNECTOR*. Therefore, no choice can be made for PORT 2 if the sexless connector types (*PC7, SEXLESS USR CONN1*) are used. Subsequent to definition of the connector of port 2, a menu for selection of the calibration procedure is called.
- For all the other calibration modes, the calibration procedure is fixed and the calibration test menu is directly called.

b) System-Error Calibration Procedure

If a softkey is pressed in the calibration test menu which is assigned to a standard, the current sweep is aborted and the measurement of the standard is started. No matter which measurement quantity was selected in the active display channel, an S-parameter which is relevant for the respective standard measurement is displayed. The system error correction for displaying this S-parameter during the calibration measurement is generally performed with the factory-set correction data, just as in case of a system-error correction initiated with *UNCAL*. Conversion, formatting and scaling are not modified. However, it is checked, whether the current IF bandwidth is equal to or smaller than 1 kHz. If it is larger, the IF bandwidth is set to 1 kHz until the end of the calibration measurement, in order to increase measurement accuracy.

After system-error correction, the instrument performs a plausibility check of the data of the standards with the factory-recorded correction data. For example, when a forward measurement is performed on a through-connection, the instrument checks whether the transmission coefficient S_{21} is ≥ 0.1 . If the result is not plausible, e.g., because a standard was incorrectly connected or the wrong standard was used, a message is displayed on the screen. The calibration can still be continued since the non-plausible data may also be caused by an external test setup where the standards were connected correctly.

The first sweep after pressing a softkey serves to acquire the test data of the standard. After this sweep, the softkey is switched on and an audio signal is generated. The height of this tone indicates whether a plausibility error occurred or not.

A measurement may be repeated any time, the standards can be measured in any order. The *APPLY CAL* softkey, which initiates calculation of the correction coefficients and subsequent return to the main menu of the *CAL* key, can not be activated until all standards required have been measured at least once. The calculation can be aborted manually.

After calculation of the correction coefficients has been correctly terminated, the *UNCAL* softkey is switched off, the enhancement label *CAL* is switched on and the data are stored on the hard disk together with the instrument setting under a default file name. The instrument switches back to the last test parameter selected in the active display channel provided that the new correction values can be applied to this test parameter. If this requirement is not met (e.g., if S_{22} was selected and a unidirectional calibration has been carried out in forward direction, or if the previous test parameter was not an S-parameter), the S-parameter of the last standard measurement performed is retained. The original IF bandwidth is reset.

If an open standard is used for the selected calibration procedure, it is permissible to leave the test port open when measuring this standard at frequencies lower than approximately 100 MHz. At 100 MHz, the parasitic stray capacitance of a typical open standard causes a phase deviation of approximately 0.4° compared to an ideal open. Decreasing the frequency reduces the error proportionately. The open standard should, however, be connected at frequencies above 100 MHz. Otherwise, if the test ports were left open, measurement errors up to 1 dB or 10° at 10 GHz would occur due to radiation losses and undefined stray capacitances.

For those calibration procedures which require measurement of a matched termination, either a matched broadband termination or a sliding load may be used. Note that a sliding load has a typical

lower frequency limit of 2 GHz. If the sweep range includes lower frequencies, the broadband termination must be measured additionally. Broadband termination and sliding load can be measured in arbitrary order. However, the measurement results of the sliding load have a higher priority than those of the broadband termination. The softkeys for sliding load measurement are always located in the right supplementary menu on the same position as the broadband termination.

A sliding load must be measured in five different positions. So, the corresponding softkey (e.g. *SLIDE PORT 1*) only reaches the switch-on state after the fifth measurement. The number of measurements already performed is displayed in a message window.

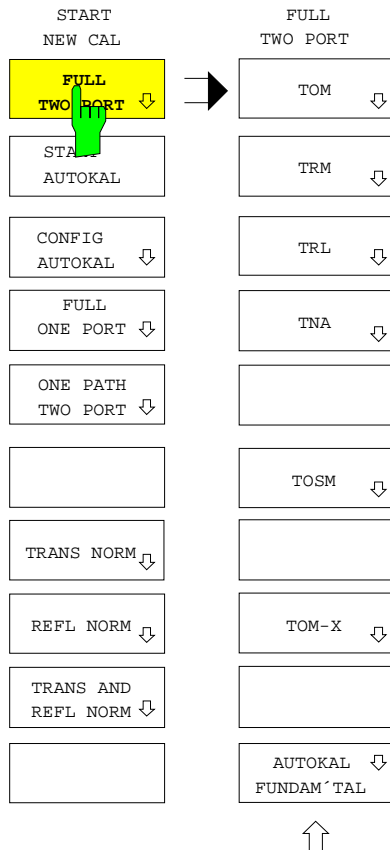
After 5 measurements, a new measurement overwrites the oldest one.

2.15.1.1.2 Full Two-port Calibration (ZVR, ZVC, ZVK and ZVM)

The calibration mode "full two-port calibration" can only be carried out in the internal mode, since it requires conversion of the test-signal direction.

For procedures which use an unknown reflection standard (*REFLECT*), it is necessary that the electrical characteristics of the reflection standards are identical when both test ports are measured. If test port connectors of differing polarity are selected, the instrument checks for agreement using the saved data of the calibration standard (*CAL - MODIFY CAL KIT* menu). A warning is displayed if *MALE* and *FEMALE REFLECT* differ.

CAL CAL - START NEW CAL - FULL TWO PORT submenu:



The *FULL TWO PORT* softkey selects the calibration mode complete two-port calibration.

The *FULL TWO PORT* menu offers selection of different calibration procedures:

- Normally, the *TOM* (THROUGH-OPEN-MATCH) procedure is recommended. It contains an implicit verification, making it easier for calibration errors to be detected.
- The *TRM* (THROUGH-REFLECT-MATCH), *TRL* (THROUGH-REFLECT-LINE) and *TNA* (THROUGH-NETWORK-ATTENUATION) procedures use standards which need not always meet high requirements. They are particularly appropriate for line types where conventional standards are difficult to obtain (e. g. planar lines). In addition, an especially high effective directivity can be reached with the *TRL* procedure.
- *TOSM* (THROUGH-OPEN-SHORT-MATCH) is the classical 12-term procedure,
- *TOM-X* (THROUGH-OPEN-MATCH- CROSSTALK) is a calibration which correctly takes into account all crosstalk errors, even those which depend on the DUT.
- *AUTOKAL FUNDAM TAL* is the fundamental calibration of the Autokal procedure. This calibration is based on the *TOM* procedure and the same standards are used.

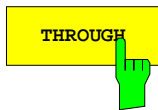
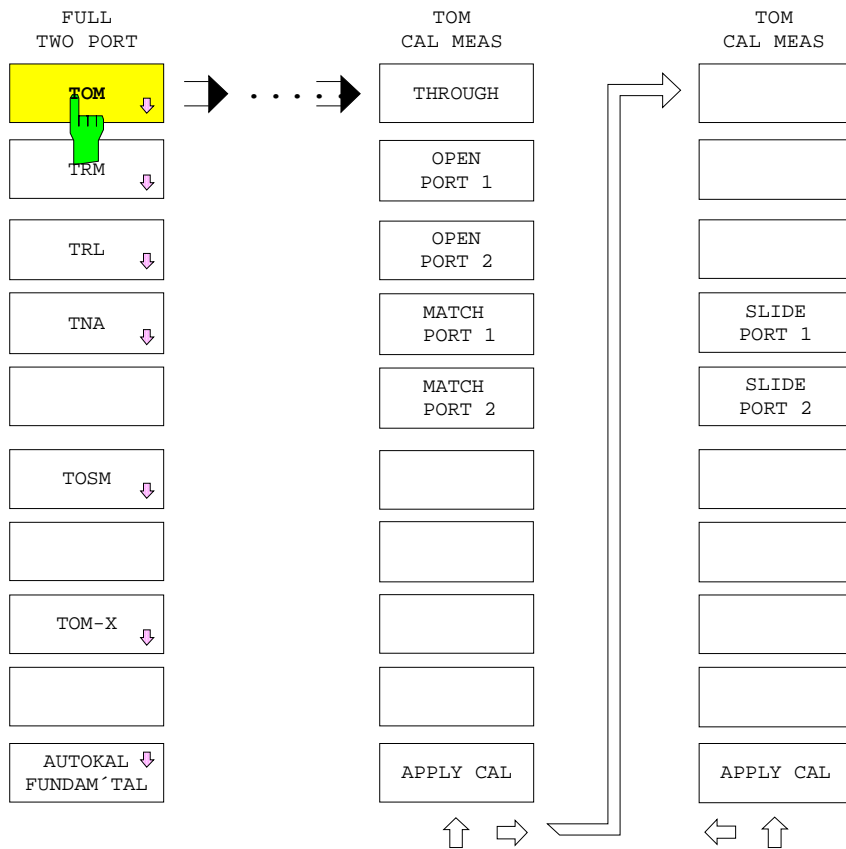
After selection of a calibration procedure, the corresponding calibration test menu is called.

a) TOM Calibration Procedure

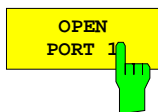
The *TOM* softkey selects the THROUGH-OPEN-MATCH calibration procedure. For the ZVR, ZVC, ZVK and ZVM, this is the preferable calibration procedure for two-port measurements. The required standards are: a low-reflection, low-loss through-connection (THROUGH), the length of which may be different from zero, an open circuit (OPEN) and a matched termination (MATCH).

Since the two known one-port standards are connected to both test ports, the error parameters are over-determined. This redundancy is used for an additional implicit verification of the calculation of correction coefficients. Thus, typical calibration errors, such as the use of wrong standards, loose screwed connections, defective cables etc. can be detected immediately.

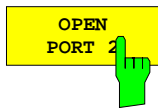
CAL CAL - START NEW CAL - FULL TWO PORT - TOM CAL MEAS submenu:



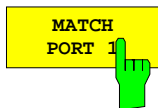
The *THROUGH* softkey starts the measurement of the through-connection between test ports 1 and 2.



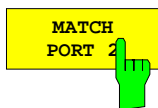
The *OPEN PORT 1* softkey starts the measurement of the open circuit at test port 1.



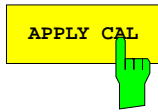
The *OPEN PORT 2* softkey starts the measurement of the open circuit at test port 2.



The *MATCH PORT 1* softkey starts the measurement of the matched termination at test port 1.

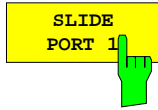


The *MATCH PORT 2* softkey starts the measurement of the matched termination at test port 2.



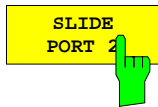
The *APPLY CAL* softkey terminates the measurement of the calibration standard and initiates calculation of the correction data.

This softkey can be activated only, if the required standards have been measured at least one time. If the implicit verification detects an error, the user is asked whether to continue the calibration or not.



The *SLIDE PORT 1* softkey starts a measurement of the sliding load at test port 1.

For special features of the sliding load measurement, see section 2.15.1.0.1.



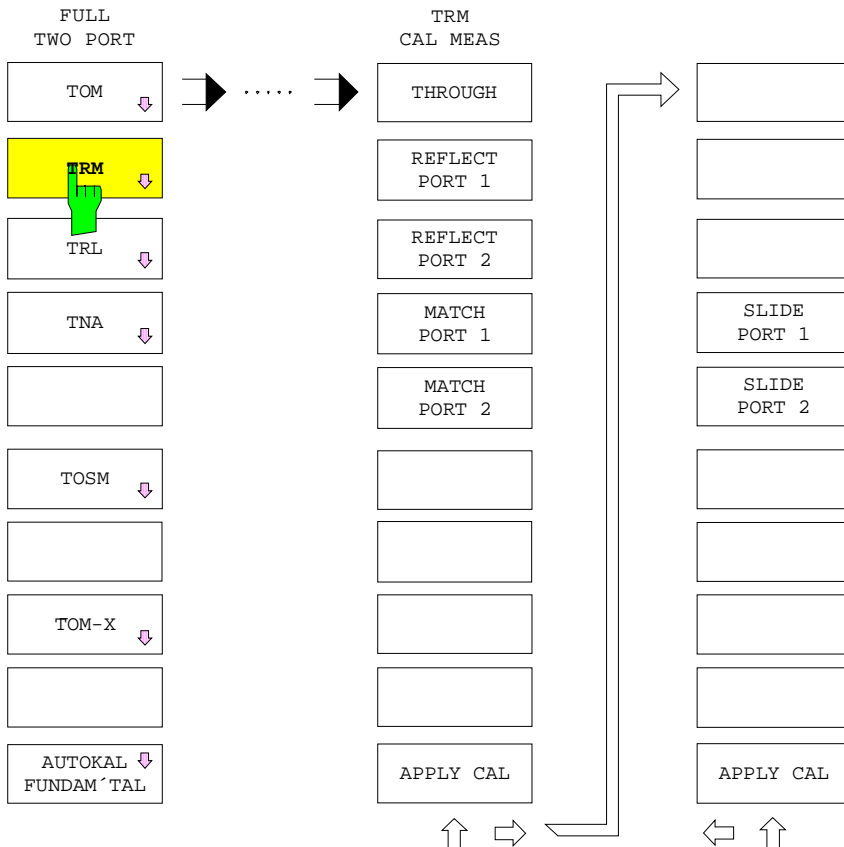
The *SLIDE PORT 2* softkey starts a measurement of the sliding load at test port 2.

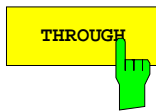
For special features of the sliding load measurement, see section 2.15.1.0.1.

b) TRM Calibration Procedure

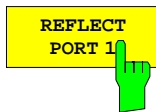
The *TRM* softkey selects the calibration procedure THROUGH-REFLECT-MATCH. A through-connection (THROUGH) which is as free of attenuation and reflection as possible, any unknown reflecting one-port standard (REFLECT) which must show the same electrical characteristics at both ports, and a matched termination (MATCH) are required as standards.

CAL CAL - START NEW CAL - FULL TWO PORT - TRM CAL MEAS submenu:

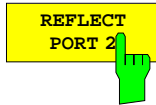




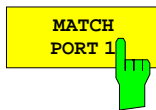
The *THROUGH* softkey starts the measurement of the through-connection between test ports 1 and 2.



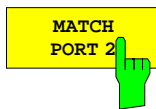
The *REFLECT PORT 1* softkey starts the measurement of the unknown one-port standard at test port 1.



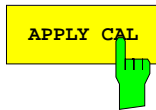
The *REFLECT PORT 2* softkey starts the measurement of the unknown one-port standard at test port 2.



The *MATCH PORT 1* softkey starts the measurement of the matched termination at test port 1.

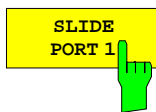


The *MATCH PORT 2* softkey starts the measurement of the matched termination at test port 2.



The *APPLY CAL* softkey terminates the measurement of the calibration standards and initiates the calculation of the correction coefficients.

This softkey can only be activated, if all standards required have been measured at least one time.



The *SLIDE PORT 1* softkey starts a measurement of the sliding load at test port 1.

For special features of the sliding load measurement, see section 2.15.1.0.1.



The *SLIDE PORT 2* softkey starts a measurement of the sliding load at test port 2.

For special features of the sliding load measurement, see section 2.15.1.0.1.

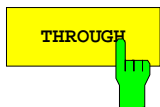
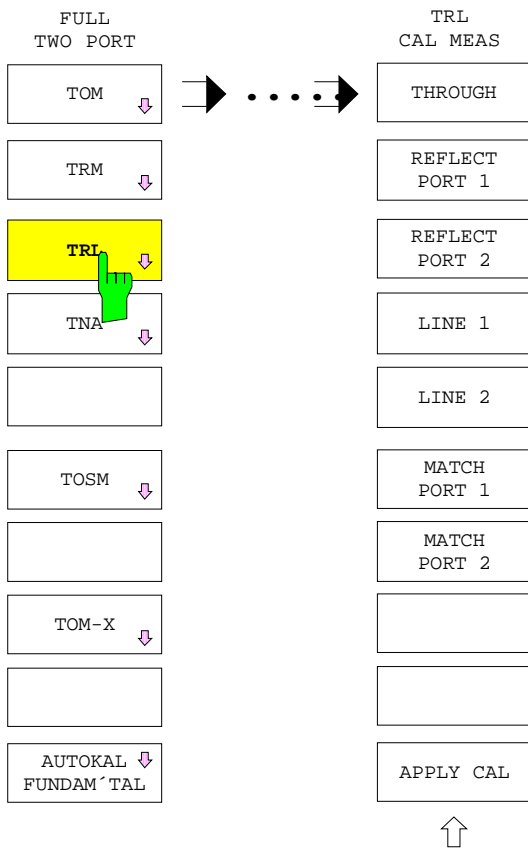
c) TRL Calibration Procedure

The *TRL* softkey selects the THROUGH-REFLECT-LINE calibration procedure. A through-connection (THROUGH) which is as free of attenuation and reflection as possible, any unknown reflecting one-port standard (REFLECT) which must show the same electrical characteristics at both ports, and a line (LINE) which is as free of reflection and attenuation as possible are required as standards.

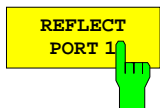
The difference in length between the through-connection and the line must not be an integer multiple of half of the wave length, since this would cause a singularity to occur. Therefore, the frequency range for the calibration measurement of the line standard is limited by the condition that the phase difference of the transmission coefficients must be between 20° and 160°, or that the maximum ratio of the stop frequency to the start frequency must be 8:1.

In order to extend the frequency range of the TRL calibration procedure, two lines of different length can be measured. Besides, the TRL calibration can be completed by a TRM calibration below the frequency limit of the longer of the two lines. The additional measurement of a reflection-free MATCH is provided for this purpose. However, only the calibrations required for the current sweep range have to be performed.

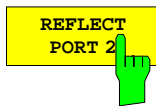
CAL CAL - START NEW CAL - FULL TWO PORT - TRL CAL MEAS submenu:



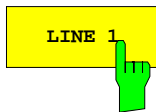
The *THROUGH* softkey starts the measurement of the through-connection between the test ports 1 and 2.



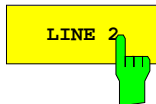
The *REFLECT PORT 1* softkey starts the measurement of the unknown one-port standard at test port 1.



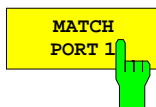
The *REFLECT PORT 2* softkey starts the measurement of the unknown one-port standard at test port 2.



The *LINE 1* softkey starts the measurement of line 1 between the test ports 1 and 2. The frequency range of this measurement is limited by the condition that the phase difference between the transmission coefficients of line 1 and the through-connection of the current calibration set must be between 20° and 160° . If line 2 is also measured (*LINE 2*) and the frequency ranges of the two measurements overlap, the measured values of the longer of the two lines are used in the lower half of the overlapping range and those of the shorter in the upper half.

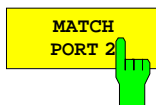


The *LINE 2* softkey starts the measurement of line 2. The measurement is performed analogously to that of line 1 (see *LINE 1* softkey).



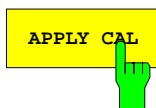
The *MATCH PORT 1* softkey starts the measurement of the matched termination at test port 1.

This is required for the completing TRM calibration, if the start frequency of the sweep is below the limit resulting from the 20° -phase difference between the through-connection and the longer of the two lines. This calibration measurement covers the completing lower frequency range only.



The *MATCH PORT 2* softkey starts the measurement of the matched termination at test port 2.

This is required for the completing TRM calibration, if the start frequency of the sweep is below the limit resulting from the 20° -phase difference between the through-connection and the longer of the two lines. This calibration measurement covers the completing lower frequency range only.



The *APPLY CAL* softkey terminates the measurement of the calibration standards and initiates the calculation of the correction coefficients.

This softkey can only be activated, if all standards required have been measured at least one time.

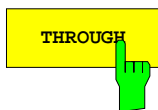
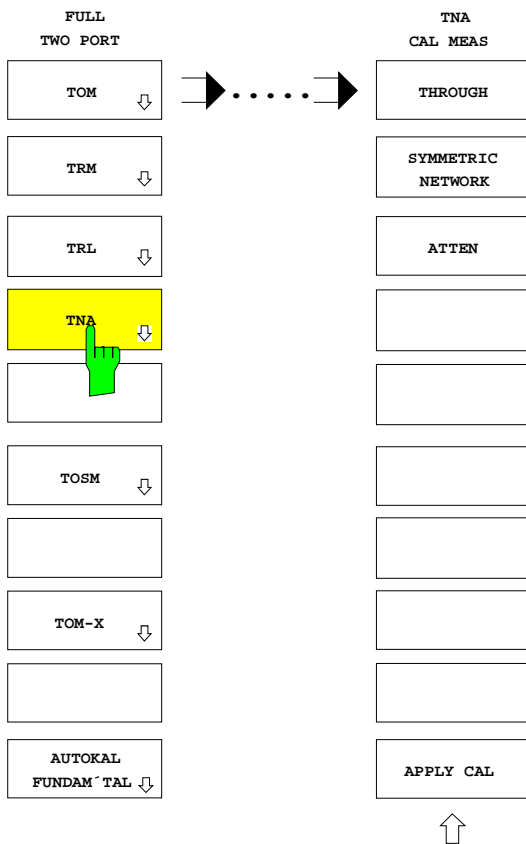
d) TNA calibration procedure

The *TNA* softkey selects the THROUGH-NETWORK-ATTENUATION calibration procedure.

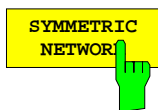
This procedure requires two-port standards, only. Apart from the *THROUGH* which should be as free of reflection and attenuation as possible, an attenuation standard (*ATTENUATION*) is to be measured which must be matched on both sides but which may provide any transmission coefficient. The attenuation must be sufficiently different from 0 dB. The symmetric network standard must feature reflection symmetry (*SYMMETRIC NETWORK*), the reflection coefficient must be different from 0.

TNA can be interpreted as TRM procedure which allows for transmission at the "double one-port standards" *REFLECT/REFLECT* or *MATCH/MATCH*. This calibration method provides an additional result, namely the attenuation supposed to be unknown caused by the *ATTENUATION* standard. This value is checked; if it is larger than 10 dB, a warning is displayed.

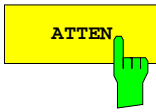
CAL CAL - START NEW CAL - FULL TWO PORT - TNA CAL MEAS submenu:



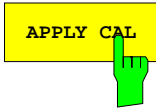
The *THROUGH* softkey starts the measurement of the through-connection between the test ports 1 and 2.



The *SYMMETRIC NETWORK* softkey starts the measurement of the reflection-symmetric network between the test ports 1 and 2.



The *ATTEN* softkey starts the measurement of the matched attenuation standard between the test ports 1 and 2.



The *APPLY CAL* softkey terminates the measurement of the calibration standard and initiates calculation of the correction data.

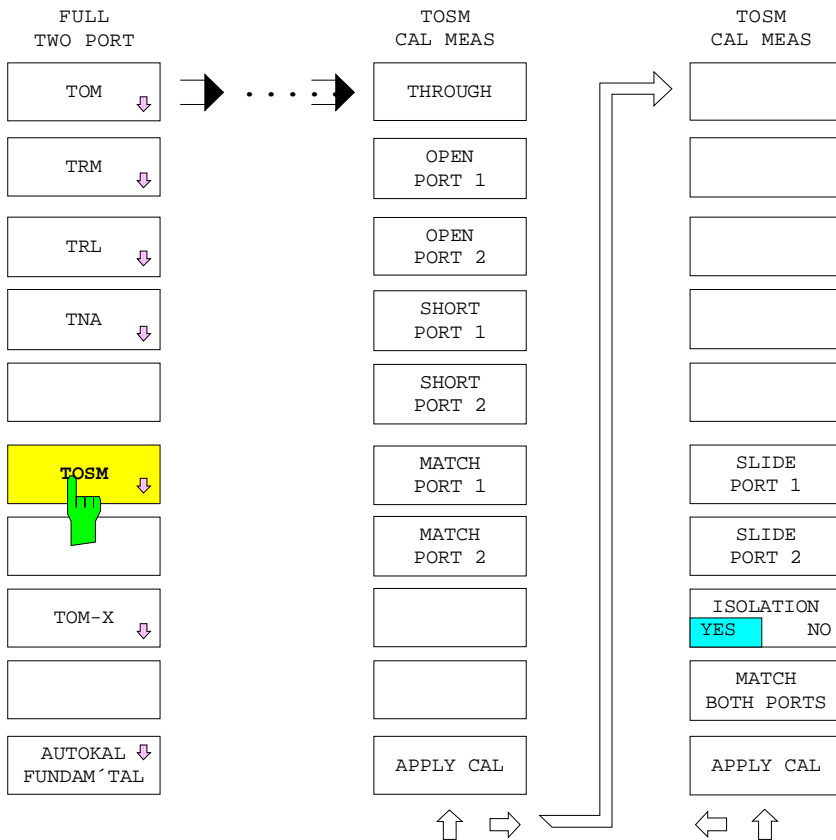
This softkey can be activated only, if the required standards have been measured at least one time. If the implicit verification detects an error, the system asks whether to continue the calibration or not.

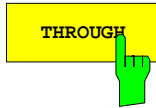
e) TOSM calibration procedure

The *TOSM* softkey selects the THROUGH-OPEN-SHORT-MATCH calibration procedure which is also called SOLT- or 12-term procedure. (Please note that the L in SOLT stands for LOAD = MATCH and not for LINE.)

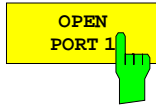
This procedure requires a matched, no-loss THROUGH, the one-port standards OPEN, SHORT and MATCH, which are connected to both test ports, each.

CAL CAL - START NEW CAL - FULL TWO PORT - TOSM CAL MEAS submenu:

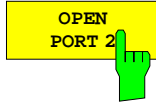




The *THROUGH* softkey starts the measurement of the through-connection between the test ports 1 and 2.



The *OPEN PORT 1* softkey starts the measurement of the open circuit at test port 1.



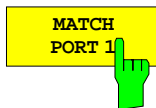
The *OPEN PORT 2* softkey starts the measurement of the open circuit at test port 2.



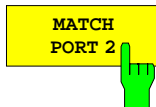
The *SHORT PORT 1* softkey starts the measurement of the short circuit at test port 1.



The *SHORT PORT 2* softkey starts the measurement of the short circuit at test port 2.



The *MATCH PORT 1* softkey starts the measurement of the matched termination at test port 1.

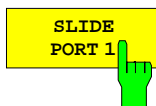


The *MATCH PORT 2* softkey starts the measurement of the matched termination at test port 2.



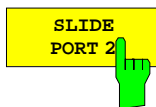
The *APPLY CAL* softkey terminates the measurement of the calibration standard and initiates calculation of the correction data.

This softkey can be activated only, if the required standards have been measured at least one time.



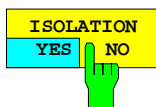
The *SLIDE PORT 1* softkey starts a measurement of the sliding load at test port 1.

For special features of the sliding load measurement, see section 2.15.1.0.1.



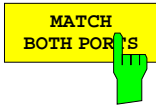
The *SLIDE PORT 2* softkey starts a measurement of the sliding load at test port 2.

For special features of the sliding load measurement, see section 2.15.1.0.1.



The *ISOLATION YES/NO* softkey specifies whether a crosstalk error between the test ports has to be taken into account or not in a TOSM calibration.

If the switch position *YES* is selected, the measurement of crosstalk has to be performed using the *MATCH BOTH PORTS* softkey. The default setting is *NO*.



The *MATCH BOTH PORTS* softkey starts the measurement of crosstalk between the test ports, whereby terminators must be fastened to both ports.

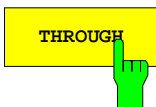
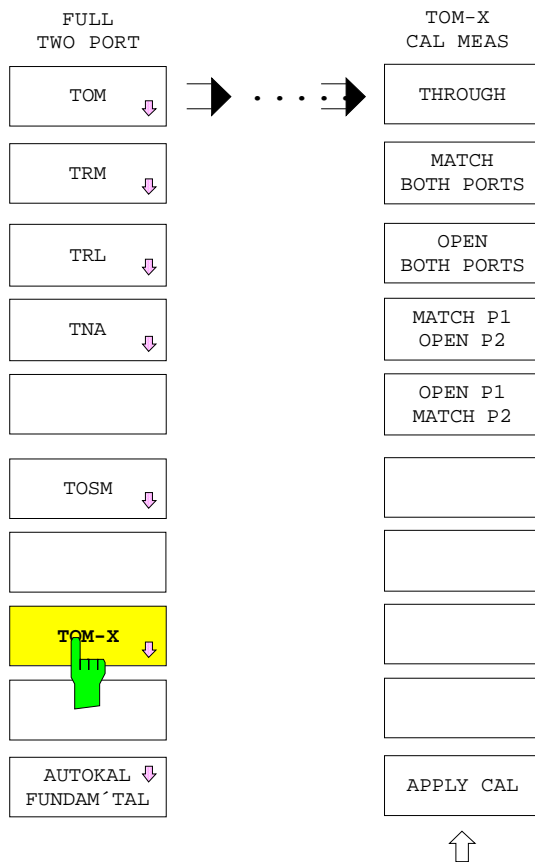
This softkey can only be activated when *ISOLATION* is in the *YES* state.

f) TOM-X calibration procedure

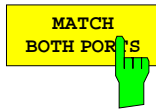
The *TOM-X* softkey selects the THROUGH-OPEN-MATCH calibration procedure which has been extended to 15 error terms (complete model).

It is the only calibration procedure which allows for mathematically correctly detecting all crosstalk errors in the test setup (X means crosstalk) Apart from a matched, no-loss THROUGH, two matched terminations (*MATCH*) and open circuits (*OPEN*) are required. The one-port standards are measured in four different pairs.

CAL CAL - START NEW CAL - FULL TWO PORT - TOM-X CAL MEAS submenu:

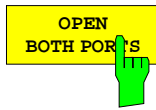


The *THROUGH* softkey starts the measurement of the through-connection between both of the test ports 1 and 2.



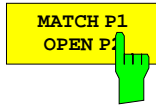
The *MATCH BOTH PORTS* softkey starts the measurement of matched terminations.

The latter must be connected to the test ports simultaneously.



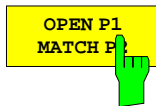
The *OPEN BOTH PORTS* softkey starts the measurement of the open circuits.

The latter must be connected to the test ports simultaneously.



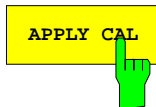
The *MATCH P1 OPEN P2* softkey the measurement of the matched termination at test port 1 and measurement of the open circuit at test port 2.

The standards must be connected to the test ports simultaneously.



The *OPEN P1 MATCH P2* softkey starts the measurement of the open circuit at test port 1 and measurement of the matched termination at test port 2.

The standards must be connected to the test ports simultaneously.



The *APPLY CAL* softkey terminates the measurement of the calibration standard and initiates calculation of the correction data.

This softkey can be activated only, if the required standards have been measured at least one time.

g) AutoKal fundamental calibration

CAL CAL - START NEW CAL - FULL TWO PORT submenu:



The *AUTOKAL FUNDAM TAL* softkey calls the calibration test menu for a fundamental calibration of the AutoKal procedure.

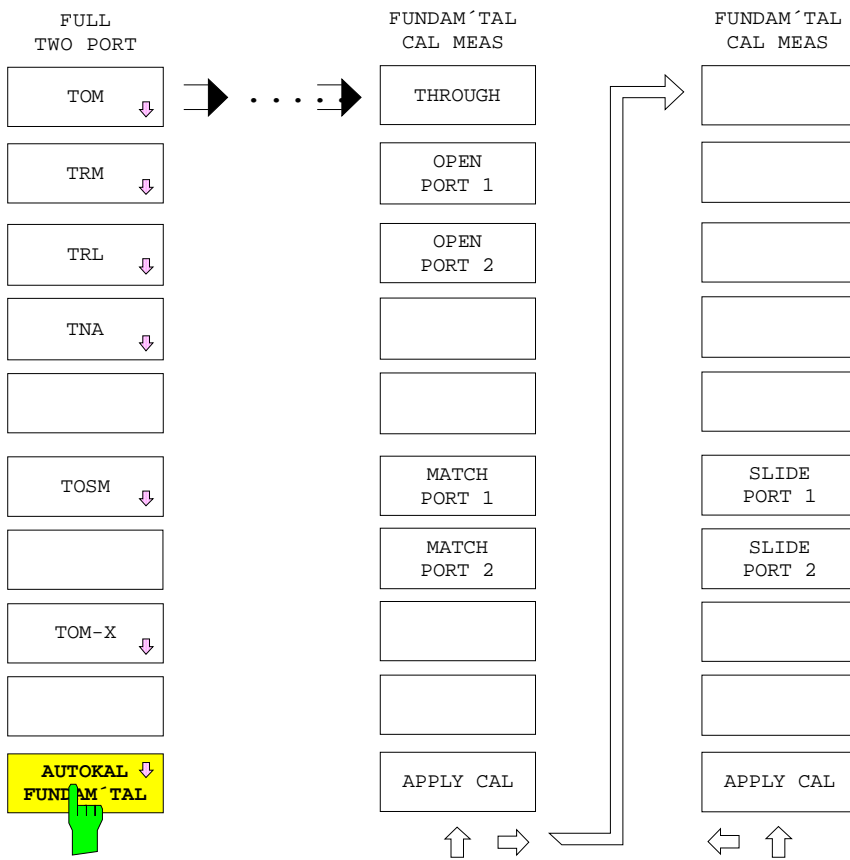
The AutoKal procedure can only be used together with the option ZVR-B1 (AutoKal add-on module). See the description of the *AUTOKAL* softkey for instructions on connecting the AutoKal add-on module to the network analyzer (section 2.15.1.1.3).

Apart from the position of some softkeys, the *AUTOKAL FUNDAM TAL* menu does not differ from that of the TOM calibration, which the fundamental calibration is based on. The description of the individual softkeys can be looked up in the description of the *TOM CAL MEAS* menu. However, this procedure requires three sweeps for the through standard, since the latter must be measured in three different switching states of the AutoKal add-on module.

The usual plausibility checks are carried out for the measurement of the standards as well as for the switching states of the AutoKal add-on module (see *AUTOKAL* softkey). As in the TOM procedure, the calculation of the correction data like the TOM procedure includes an implicit verification.

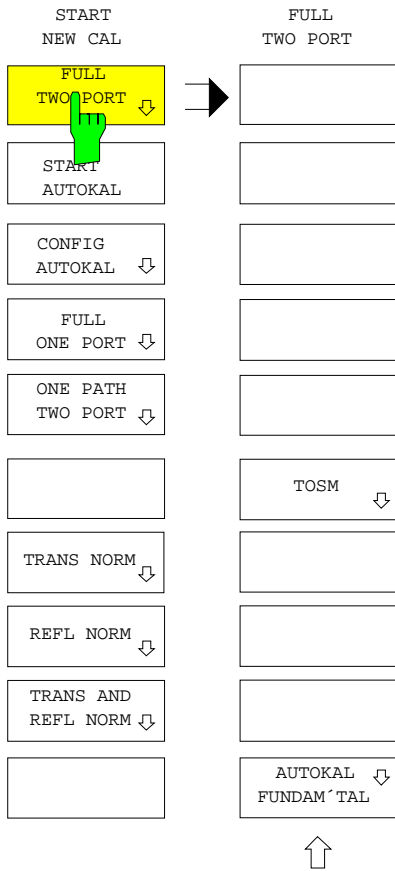
After an AutoKal fundamental calibration, the network analyzer is calibrated in the same way as with a TOM calibration. In addition, the AutoKal add-on module features measured during fundamental calibration are stored in a data set, which will be used later for transfer calibration. Section 2.15.1.1.4 describes the management and activation of these data sets.

CAL CAL - START NEW CAL - FULL TWO PORT - AUTOKAL FUNDAM'TAL submenu:



2.15.1.1.3 Full two-port calibration (ZVRE, ZVCE)

CAL CAL - START NEW CAL - FULL TWO PORT submenu:



The *FULL TWO PORT* softkey selects the complete two-port calibration mode.

Full two-port calibration can only be carried out in the internal mode, since it requires conversion of the test-signal direction.

Two calibration procedures are offered:

- the classical 12 term or TOSM (THROUGH-OPEN-SHORT-MATCH) procedure,
- the AutoKal fundamental calibration which is based on TOSM.

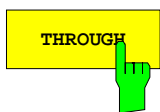
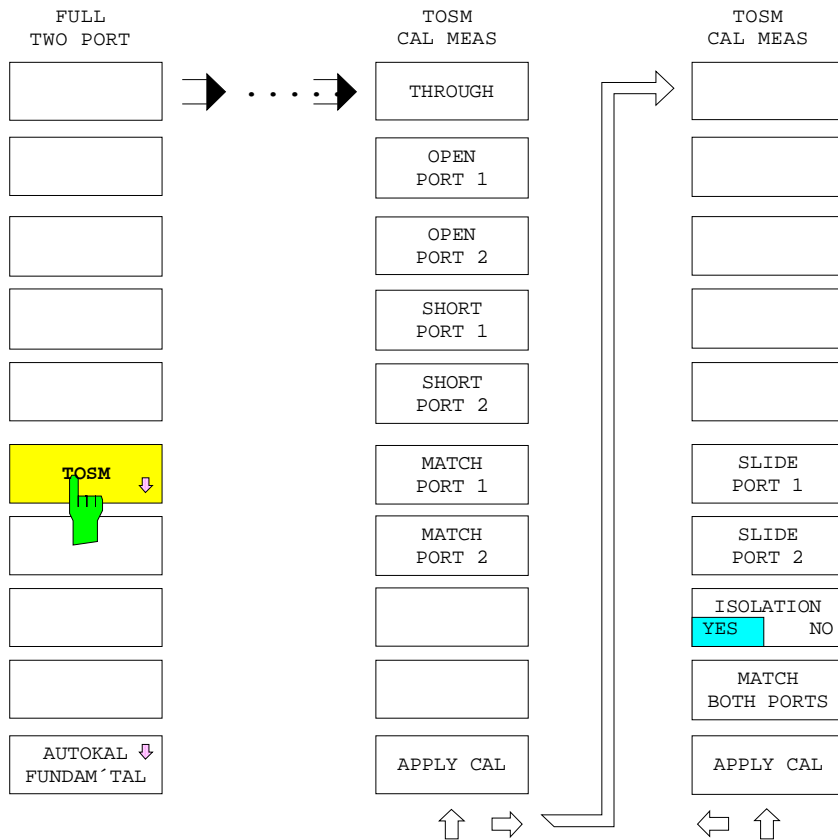
After selection of a calibration procedure, the corresponding calibration test menu is called.

a) TOSM calibration

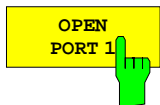
The *TOSM* softkey selects the THROUGH-OPEN-SHORT-MATCH calibration which is also known as SOLT or 12-term calibration. (Please note that the L in SOLT stands for LOAD = MATCH and not for LINE.)

Apart from a matched, no-loss through-connection (THROUGH), this procedure requires the one-port standards OPEN, SHORT and a matched termination (MATCH), which are each connected to both test ports.

CAL CAL - START NEW CAL - FULL TWO PORT -TOSM CAL MEAS submenu:



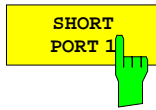
The *THROUGH* softkey starts the measurement of the through-connection between the test ports 1 and 2.



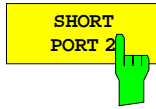
The *OPEN PORT 1* softkey starts the measurement of the open circuit at test port 1.



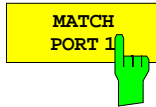
The *OPEN PORT 2* softkey starts the measurement of the open circuit at test port 2.



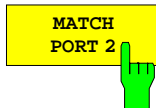
The *SHORT PORT 1* softkey starts the measurement of the short circuit at test port 1.



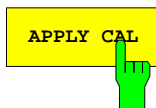
The *SHORT PORT 2* softkey starts the measurement of the short circuit at test port 2.



The *MATCH PORT 1* softkey starts the measurement of the matched termination at test port 1.

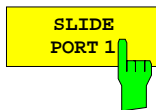


The *MATCH PORT 2* softkey starts the measurement of the matched termination at test port 2.



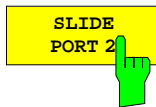
The *APPLY CAL* softkey terminates the measurement of the calibration standard and initiates calculation of the correction data.

This softkey can be activated only, if the required standards have been measured at least one time.



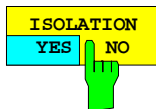
The *SLIDE PORT 1* softkey starts a measurement of the sliding load at test port 1.

For special features of the sliding load measurement, see section 2.15.1.0.1.



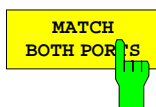
The *SLIDE PORT 2* softkey starts a measurement of the sliding load at test port 2.

For special features of the sliding load measurement, see section 2.15.1.0.1.



The *ISOLATION YES NO* softkey specifies whether a crosstalk error between the test ports has to be taken into account or not during a TOSM calibration. The default setting is *NO*.

If the switch position *YES* is selected, the measurement of crosstalk has to be performed using the *MATCH BOTH PORTS* softkey.



The *MATCH BOTH PORTS* softkey starts the measurement of crosstalk between the test ports, whereby terminators must be fastened to both ports.

This softkey can only be activated when *ISOLATION* is in the *YES* state.

b) AutoKal Fundamental Calibration

CAL CAL - START NEW CAL - FULL TWO PORT submenu:



The *AUTOKAL FUNDAM TAL* softkey calls the calibration test menu for a fundamental calibration of the AutoKal procedure.

The AutoKal procedure can only be used together with the option ZVR-B1 (AutoKal add-on module). See the description of the *AUTOKAL* softkey for instructions on connecting the AutoKal add-on module to the network analyzer (section 2.15.1.1.3).

Apart from the position of some softkeys, the *AUTOKAL FUNDAM TAL* menu does not differ from that of the TOSM calibration, which the fundamental calibration is based on. The description of the individual softkeys can be looked up in the description of the *TOSM CAL MEAS* menu (see above). However, this procedure requires three sweeps for the through standard, since the latter must be measured in three different switching states of the AutoKal add-on module.

The usual plausibility checks are carried out for the measurement of the standards as well as for the switching states of the AutoKal add-on module (see *AUTOKAL* softkey).

After an AutoKal fundamental calibration, the network analyzer is calibrated in the same way as with a TOSM calibration. In addition, the AutoKal add-on module features measured during fundamental calibration are stored in a data set, which will be used later for transfer calibration. Section 2.15.1.1.4 describes the management and activation of these data sets.

2.15.1.1.4 Automatic Two-port Transfer Calibration

Like fundamental calibration, automatic two-port transfer calibration (AutoKal) is only possible in conjunction with option ZVR-B1 (AutoKal add-on module).

The AutoKal add-on module has a switchable transfer standard. This is a standard which can assume different states with high repeat accuracy. For an AutoKal fundamental calibration, the characteristics of each state are determined and stored in a data set. The measurement uncertainty after transfer calibration depends on the uncertainty of the transfer standard, which cannot be less than the measurement uncertainty after fundamental calibration. For this reason, fundamental calibration, in which standards are individually connected in the usual way, should be performed with extreme care since a certain loss in accuracy between fundamental and transfer calibration is unavoidable.

AutoKal transfer calibration cannot be performed unless a data set of a fundamental calibration is available. All data sets stored in the analyzer are listed in the *ACTIVE AUTOKAL UNIT DATA SET* table which can be called by means of the *CAL - START NEW CAL - CONFIG AUTOKAL* softkey. The data set used in a subsequent transfer calibration is ticked.

The AutoKal add-on module has four ports. The two ports at the front are labelled PORT 1 and PORT 2. Prior to fundamental or transfer calibration, the left rear port of the add-on module must be connected to PORT 1 of the network analyzer, and the right rear port to PORT 2. Cables may be used for these connections. PORT 1 and PORT 2 of the add-on module are connected together. It is essential to insert the same two-port (cable or similar) between PORT 1 and the measurement port as used for the fundamental calibration and also to use the same through standard (THROUGH). If the add-on module is to be removed after calibration (see below), the whole network, which will later be connected to the measurement ports to perform transfer calibration, must be identical to that used for fundamental calibration. This means that the cables and adapters between the measurement ports and the add-on module, as well as the through connection between PORT 1 and PORT 2 on the add-on module should be connected in exactly the same way as for the associated fundamental calibration. The flat cable of the add-on module is connected to the USER connector on the rear panel of the analyzer.

The AutoKal add-on module can be used in two different ways. Either measurement ports PORT 1 and PORT 2 on the AutoKal add-on module assume the function of the analyzer measurement ports (i.e. the add-on module remains connected after transfer calibration), or the add-on module is connected for calibration only and then removed. The first possibility requires only the analyzer and option ZVR-B1; the second requires software option ZVR-K9 as well (version 3.2 and higher).

The data set of a fundamental calibration depends only on the characteristics of the AutoKal add-on module and if the add-on module is to be removed after calibration on the connected lines and adapters to the desired calibration power. The data set is not influenced by the characteristics of the network analyzer which was used for fundamental calibration. It is, therefore, possible to transfer data sets between analyzers of different types, and with different hardware components, provided they belong to the ZVx family. Special export and import functions are available for this purpose.

In the *CAL – START NEW CAL* menu, two softkeys are associated with AutoKal:

- *START AUTOKAL* starts transfer calibration with the settings selected via *CONFIG AUTOKAL*.
- In the *CONFIG AUTOKAL* submenu, it is possible to select either of the two AutoKal variants referred to above. It also contains functions for activating and managing the data sets generated during fundamental calibration or by the ZVR-K9 software.



The *START AUTOKAL* softkey starts automatic two-port transfer calibration. The fundamental calibration data set activated in the *ACTIVE AUTOKAL UNIT DATA SET* table (see *CONFIG AUTOKAL* softkey) is used.

Before the *AUTOKAL* softkey is pressed, the AutoKal add-on module should be connected as described above.

In order to ensure compatibility with fundamental calibration, its setting data is restored (compare *UNCAL* softkey).

Measurements are performed on the AutoKal add-on module in three states during fundamental calibration as with the through-connection measurement.

As for any calibration, the measured values are subjected to a plausibility check in order to determine whether the AutoKal add-on module is connected and operational.

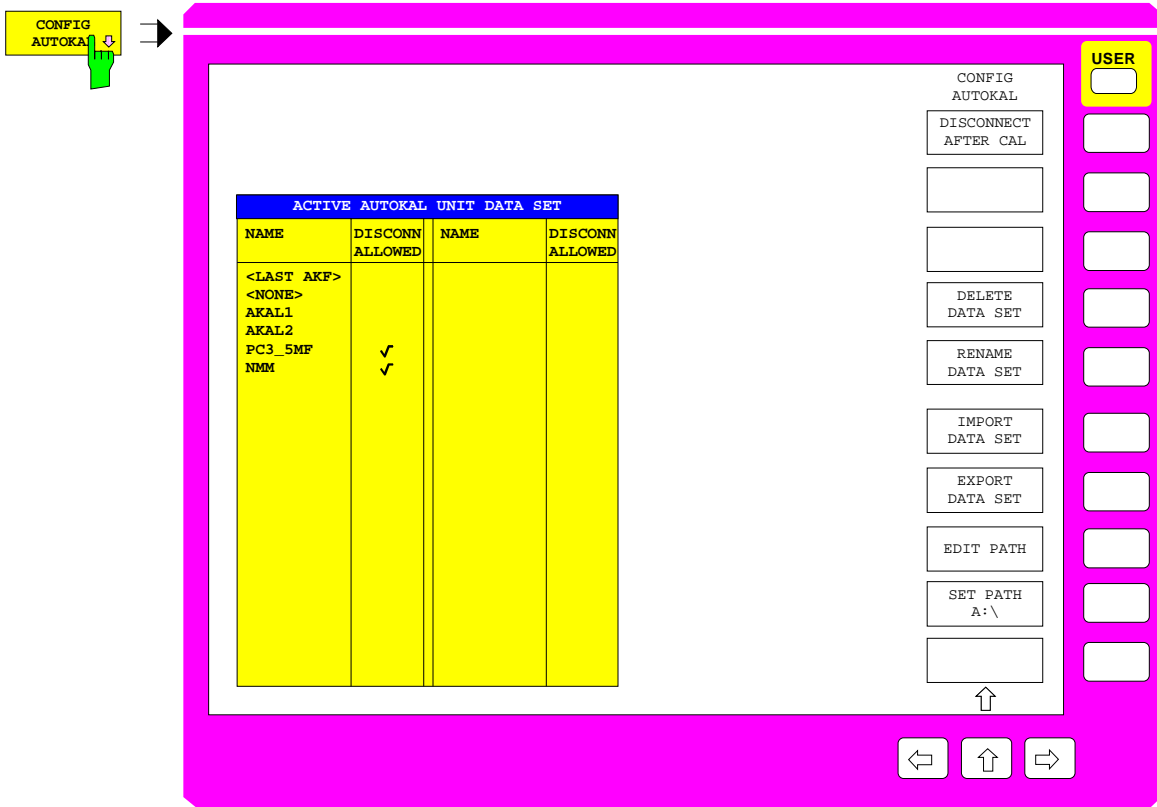


Fig. 2-39 Menu CONFIG AUTOKAL

The *CONFIG AUTOKAL* softkey calls the submenu of the same name. The *ACTIVE AUTOKAL UNIT DATA SET* table is displayed at the same time.

With the submenu functions, you can:

- select whether the AutoKal add-on module is to be removed after transfer calibration
- delete or rename fundamental calibration data sets in the *ACTIVE AUTOKAL UNIT DATA SET* table
- export or import fundamental calibration data sets

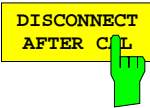
All currently stored fundamental calibration data sets are listed in the *ACTIVE AUTOKAL UNIT DATA SET* table. The table has the two following columns. Two pairs of columns are arranged next to each other.

NAME – Data set name

The data set name is displayed here. The currently active data set is ticked. It is used for the next transfer calibration. The scrollbar can be moved up and down in the *NAME* column. The data set marked with the scrollbar can be activated by pressing the ENTER key. The data set of the last fundamental calibration to be performed is assigned the name <LAST AKF>. To prevent it from being overwritten during the next fundamental calibration, it is a good idea to rename it (see *RENAME DATA SET* softkey).

DISCONN ALLOWED – Add-on module can be removed after calibration

A tick in this column indicates that the relevant data set contains additional information. This information allows the AutoKal add-on module to be removed after transfer calibration. If the active data set contains additional information, the *DISCONNECT AFTER CAL* softkey can be operated. Its switching state determines whether the system-error correction data refers to the reference plane of the AutoKal fundamental calibration or to the plane at which the add-on module is disconnected. Data sets containing additional information can only be generated by means of software option ZVR-K9 (version 3.2 or higher). The position of the disconnection plane is also defined.

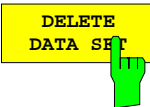


DISCONNECT
AFTER CAL

The *DISCONNECT AFTER CAL* softkey defines the position of the reference plane after the AutoKal transfer calibration.

When *DISCONNECT AFTER CAL* is in the OFF state, the reference plane of the transfer calibration is the same as the plane of the allocated fundamental calibration. If, on the other hand, the softkey is ON, the system-error correction data is calculated during transfer calibration so that they refer to a disconnection plane between the network analyzer and the AutoKal add-on module. It is then possible to disconnect the add-on module at this plane. Option ZVR-B1 can then be used like an electronic transfer standard, as produced by other manufacturers. However, the advantage of the AutoKal method over these solutions is that it operates with a transfer standard which can be characterized by the user during fundamental calibration. This means that a separate transfer standard is not required for each connector system; the AutoKal add-on module can be configured using adapters for the connector in question.

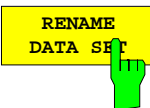
The softkey can be operated only when the active fundamental calibration data set in the *ACTIVE AUTOKAL UNIT DATA SET* table contains additional information which makes it possible to shift the reference plane to the desired disconnection plane. Data sets of this kind can only be generated by means of software option ZVR-K9 (version 3.2 or higher).



DELETE
DATA SET

The *DELETE DATA SET* softkey clears the fundamental calibration data set marked by the scrollbar from the *ACTIVE AUTOKAL UNIT DATA SET* table.

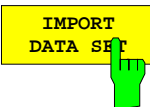
The active data set and <LAST AKF> and <NONE> data sets cannot be cleared.



RENAME
DATA SET

The *RENAME DATA SET* softkey is used to rename the fundamental calibration data set marked by the scrollbar in the *ACTIVE AUTOKAL UNIT DATA SET* table.

The active data set and <LAST AKF> and <NONE> data sets cannot be renamed.



IMPORT
DATA SET

The *IMPORT DATA SET* softkey is used to search for fundamental calibration data sets in the path defined by *EDIT PATH* or *SET PATH A:*. If only one data set is found, the *IMPORT DATA SET* entry field is displayed together with the data set name. If two or more data sets are available, they are listed in the *IMPORT AUTOKAL UNIT DATA SETS* table. You can select the data you want with the scrollbar. The selected data set is read when the ENTER key is pressed.


Note that a data set with the name AUTOKAL cannot be imported.



EXPORT
DATA SET

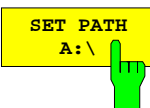
The *EXPORT DATA SET* softkey is used to export the fundamental calibration data sets marked in the *ACTIVE AUTOKAL UNIT DATA SET* table to the path defined by *EDIT PATH* or *SET PATH A:*. The name of the newly created data set can be edited in the EXPORT LOCAL UNIT DATA SET XXX TO THE DATA SET window (XXX stands for the current name in the table).

The <NONE> data set cannot be exported.



EDIT PATH

The *EDIT PATH* softkey opens the alphanumeric input field *EDIT IMPORT/EXPORT PATH* used for defining the path for performing import or export. The *SET PATH A:* is provided for fast switching of the path to the disk drive.

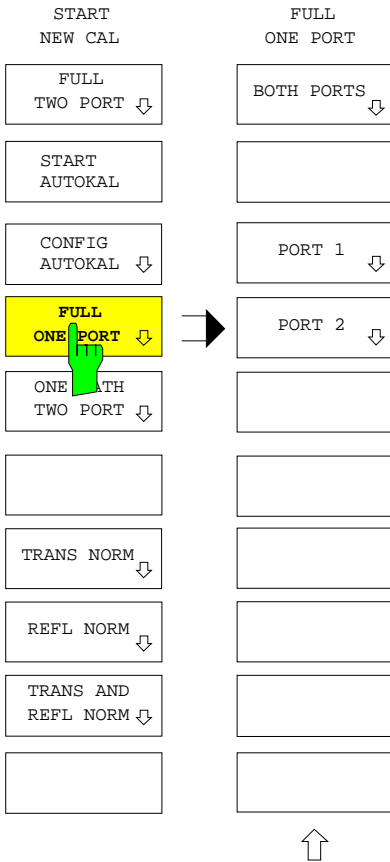


SET PATH
A:\

The *SET PATH A:* softkey is used for the fast selection of the disk drive as the import /export path.

2.15.1.1.5 Full One-port Calibration (ZVR, ZVRE; ZVC, ZVCE, ZVK, ZVM)

CAL CAL - START NEW CAL - FULL ONE PORT submenu:

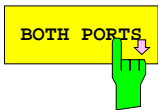


The *FULL ONE PORT* softkey opens a menu to define the full one-port calibration.

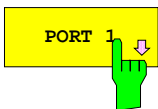
It must be defined whether to calibrate

- test port 1 (*PORT 1*),
- test port 2 (*PORT 2*), or
- both test ports (*BOTH PORTS*).

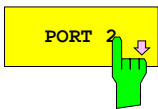
In the external measuring mode, reflection calibration at two different measurement ports (e. g. two external reflection coefficient ports) can be performed, too. Before, the definition of S_{11} and S_{22} must be adapted to the external measurement setup via *RESPONSE MEAS - USER DEF'D S-PARAMS*.



The *BOTH PORTS* softkey starts one-port calibration of both test ports.



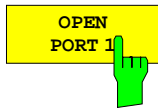
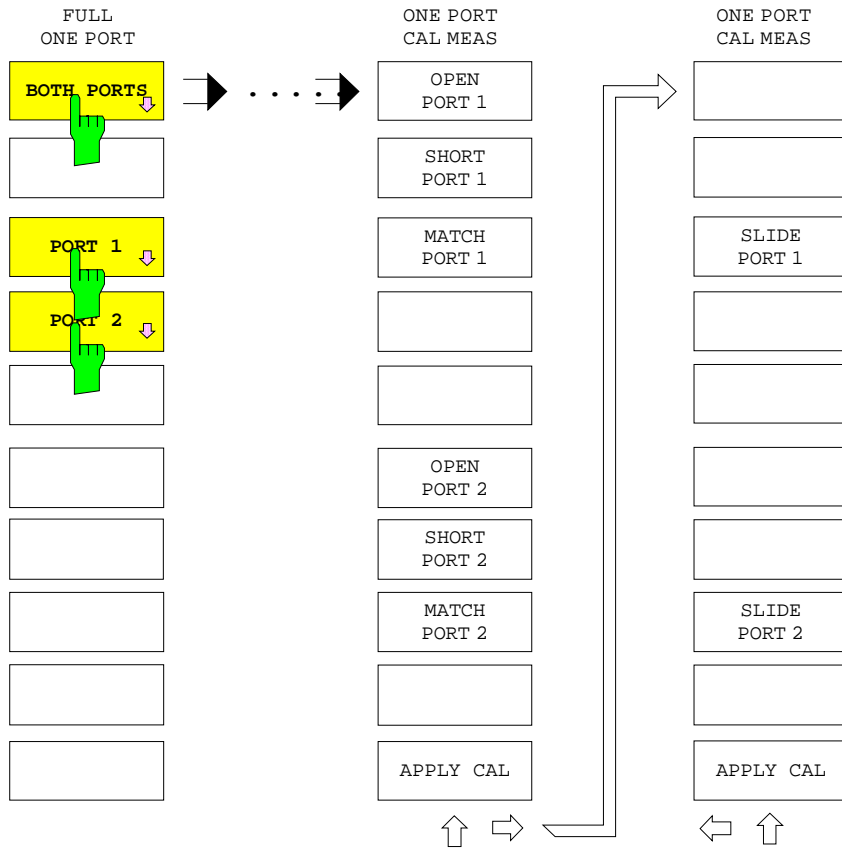
The *PORT 1* softkey starts the one-port calibration of test port 1.



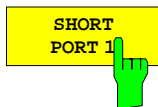
The *PORT 2* softkey starts the one-port calibration of test port 2.

Subsequent to selection of the test port connectors, the *ONE PORT CAL MEAS* menu is displayed. The OPEN, SHORT and MATCH standards have to be connected to the port which is to be calibrated. A sliding load may be used instead of a broadband fixed terminator. All softkeys which are not required for the selected calibration are disabled.

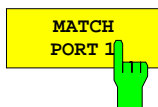
CAL CAL - START NEW CAL - FULL ONE PORT - BOTH PORTS submenu:



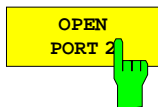
The *OPEN PORT 1* softkey starts the measurement of the open circuit at test port 1.



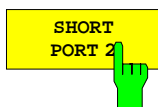
The *SHORT PORT 1* softkey starts the measurement of the short circuit at test port 1.



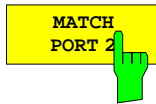
The *MATCH PORT 1* softkey starts the measurement of the matched termination at test port 1.



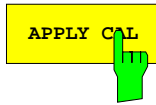
The *OPEN PORT 2* softkey starts the measurement of the open circuit at test port 2.



The *SHORT PORT 2* softkey starts the measurement of the short circuit at test port 2.

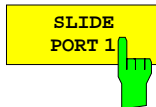


The *MATCH PORT 2* softkey starts the measurement of the matched termination at test port 2.



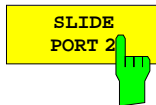
The *APPLY CAL* softkey terminates the measurement of the calibration standard and initiates calculation of the correction data.

This softkey can be activated only, if the required standards have been measured at least one time.



The *SLIDE PORT 1* softkey starts a measurement of the sliding load at test port 1.

For special features of the sliding load measurement, see section 2.15.1.0.1.



The *SLIDE PORT 2* softkey starts a measurement of the sliding load at test port 2.

For special features of the sliding load measurement, see section 2.15.1.0.1.

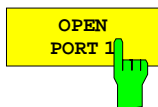
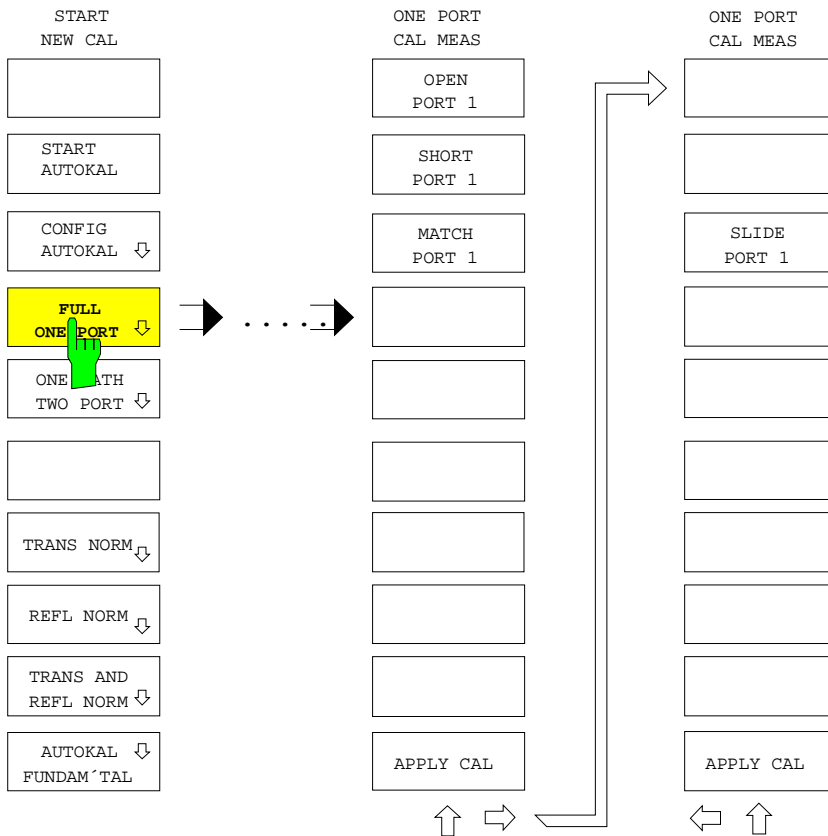
2.15.1.1.6 Full One-port Calibration (ZVRL)

The *FULL ONE PORT* softkey starts the complete one-port calibration measurement.

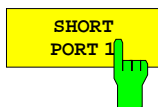
This calibration mode can be performed at test port 1 only. Subsequent to selection of the test port connector the *ONE PORT CAL MEAS* menu is displayed. The *OPEN*, *SHORT* and *MATCH* standards have to be connected to the test port. A sliding load may be used instead of the broadband fixed termination.

In the external mode, a reflection calibration can be performed as well (e. g. at an external reflection coefficient bridge). Before, the definition of S_{11} must be adapted to the external test setup via *RESPONSE MEAS - USER DEF'D S-PARAMS*.

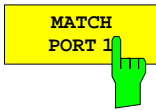
CAL CAL - START NEW CAL - FULL ONE PORT submenu:



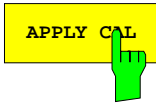
The *OPEN PORT 1* softkey starts the measurement of the open circuit at test port 1.



The *SHORT PORT 1* softkey starts the measurement of the short circuit at test port 1.

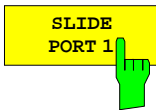


The *MATCH PORT 1* softkey starts the measurement of the matched termination at test port 1.



The *APPLY CAL* softkey terminates the measurement of the calibration standard and initiates calculation of the correction data.

This softkey can be activated only, if the required standards have been measured at least one time.



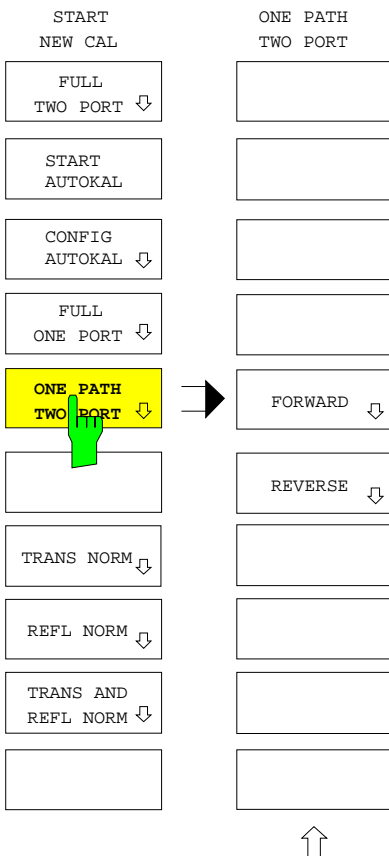
The *SLIDE PORT 1* softkey starts a measurement of the sliding load at test port 1.

For special features of the sliding-load measurement, see section 2.15.1.1.1, part b).

2.15.1.1.7 Unidirect. Two-port Calibration (ZVR, ZVRE, ZVC,ZVCE, ZVK, ZVM)

The *ONE PATH TWO PORT* menu is selected to start unidirectional calibration measurements. This type of calibration is particularly appropriate for two-port measurements in external mode, which does not allow for two-port calibration. It may also be applied in internal mode, if the S-parameters are to be measured in forward (S_{11} and S_{21}) or reverse direction (S_{22} and S_{12}). Since the direction of the test signal does not have to be converted, the measurement speed of unidirectional two-port correction is considerably higher than that of full two-port calibration.

CAL CAL - START NEW CAL submenu:



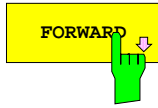
The *ONE PATH TWO PORT* softkey opens the menu for unidirectional two-port calibration.

Unidirectional calibration can be performed

- in forward (*FORWARD*) and
- in reverse direction (*REVERSE*).

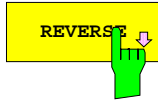
It includes a full one-port calibration at the source port (in the external mode, this requires a reflection coefficient bridge) and a transmission calibration from the source to the destination port. In the external mode, the definition of S_{11} and S_{21} (forward measurement) or S_{22} and S_{12} (reverse measurement) must be adapted to the test setup via *RESPONSE MEAS - USER DEF'D S-PARAMS*. In this case, the numerators of the two S-parameters must be different.

Errors of the transmission measurement caused by interreflections between DUT and destination port, can not be eliminated with unidirectional calibration since the mismatch of the DUT output is not measured. If the DUT outputs are mismatched, the destination port should be well matched for transmission.



The *FORWARD* softkey starts the unidirectional two-port calibration in forward direction.

It consists of full one-port calibration at test port 1 (for S_{11}) and a transmission calibration from port 1 to port 2 for (S_{21}).

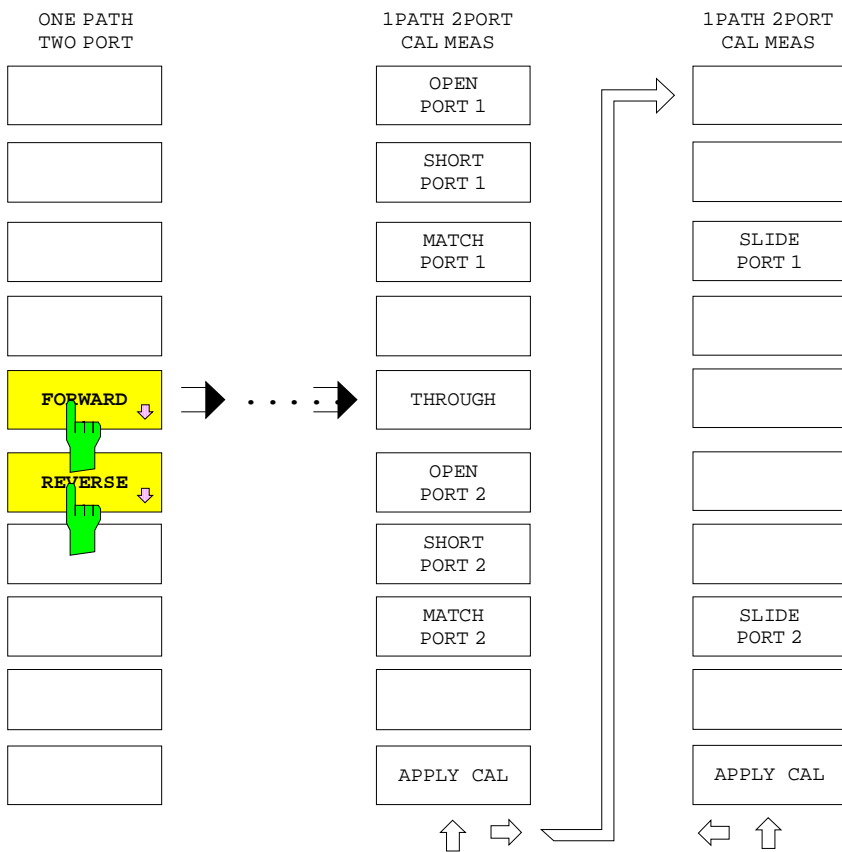


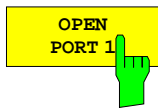
The *REVERSE* softkey starts the unidirectional two-port calibration in reverse direction.

It consists of full one-port calibration at test port 2 (for S_{22}) and a transmission calibration from port 2 to port 1 (for S_{12}).

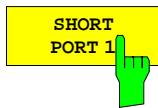
Subsequent to selection of the test port connectors, the *1PATH2 PORT CAL MEAS* menu is displayed. It corresponds to the calibration test menu for one-port calibration extended by the through-connection measurement (THROUGH), the loss and length of which are not considered. All softkeys which are not required for the selected calibration are disabled.

CAL CAL - START NEW CAL ONE PATH TWO PORT submenu:

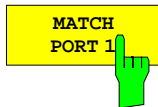




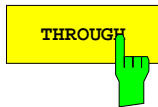
The *OPEN PORT 1* softkey starts the measurement of the open circuit at test port 1.



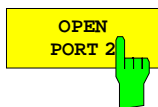
The *SHORT PORT 1* softkey starts the measurement of the short circuit at test port 1.



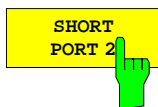
The *MATCH PORT 1* softkey starts the measurement of the matched termination at test port 1.



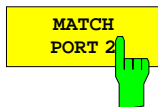
The *THROUGH* softkey starts the measurement of the through-connection between test ports 1 and 2.



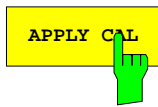
The *OPEN PORT 2* softkey starts the measurement of the open circuit at test port 2.



The *SHORT PORT 2* softkey starts the measurement of the short circuit at test port 2.

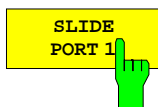


The *MATCH PORT 2* softkey starts the measurement of the matched termination at test port 2.



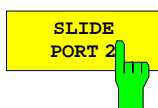
The *APPLY CAL* softkey terminates the measurement of the calibration standard and initiates calculation of the correction data.

This softkey can be activated only, if the required standards have been measured at least one time.



The *SLIDE PORT 1* softkey starts a measurement of the sliding load at test port 1.

For special features of the sliding-load measurement, see section 2.15.1.1.1, part b).



The *SLIDE PORT 2* softkey starts a measurement of the sliding load at test port 2.

For special features of the sliding-load measurement, see section 2.15.1.1.1, part b).

2.15.1.1.8 Unidirectional Two-port Calibration (ZVRL)

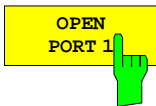
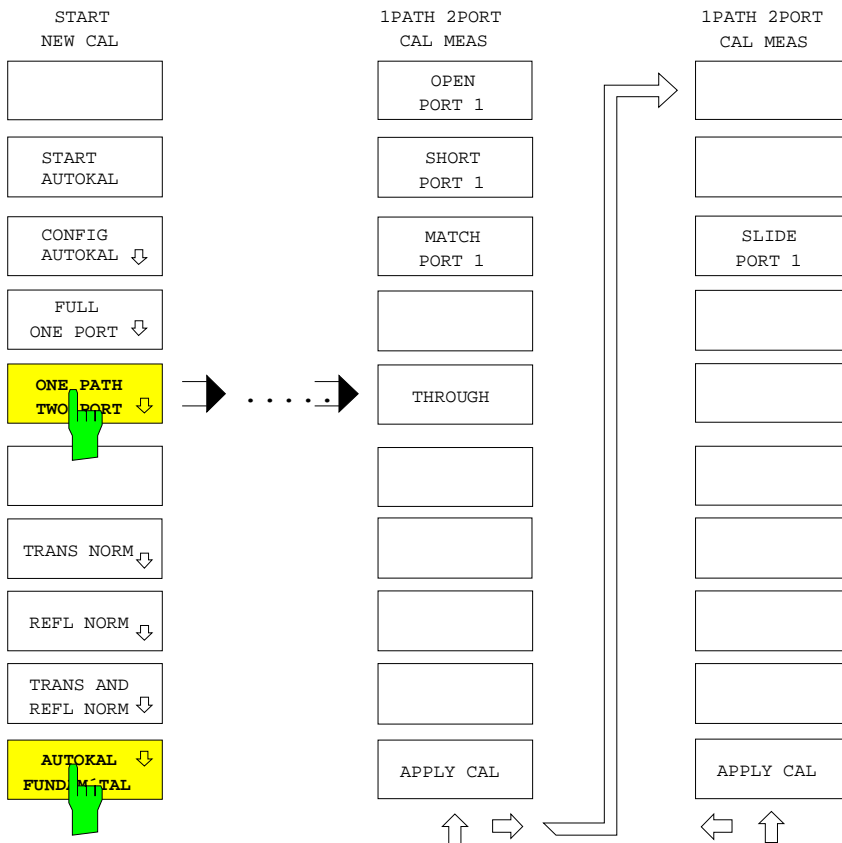
The *ONE PATH TWO PORT* softkey starts the calibration for unidirectional two-port measurements, the best calibration procedure possible for the ZVRL.

It consists of a full one-port calibration measurement at port 1 (for S_{11} , in the external mode, this requires, e. g., a reflection coefficient bridge) and a transmission calibration from port 1 to port 2 (for S_{21}). In the external mode, the definition of S_{11} and S_{21} must be adapted to the test setup via *RESPONSE MEAS - USER DEF'D S-PARAMS*. In this case, the numerators of the two S-parameters must be different.

Errors of the transmission measurement caused by interfections between DUT and destination port, can not be eliminated with unidirectional calibration since the mismatch of the DUT output is not measured. If the DUT outputs are mismatched, the destination port should be well matched for transmission.

Subsequent to selection of the connector of PORT 1, the *1PATH 2PORT CAL MEAS* menu is displayed. Similar to the full one-port calibration measurement the OPEN, SHORT and MATCH standards have to be connected to the port which is to be calibrated. A sliding load (SLIDE) may be used instead of a broadband fixed termination. The THROUGH has to be measured additionally for transmission calibration. The loss and length of the through-connection are assumed to be zero.

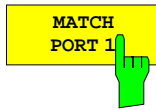
CAL CAL - START NEW CAL - ONE PATH TWO PORT submenu:



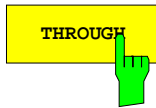
The *OPEN PORT 1* softkey starts the measurement of the open circuit at test port 1.



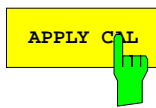
The *SHORT PORT 1* softkey starts the measurement of the short circuit at test port 1.



The *MATCH PORT 1* softkey starts the measurement of the matched termination at test port 1.

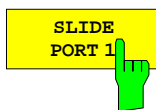


The *THROUGH* softkey starts the measurement of the through-connection between the test ports 1 and 2.



The *APPLY CAL* softkey terminates the measurement of the calibration standard and initiates calculation of the correction data.

This softkey can be activated only, if the required standards have been measured at least one time.



The *SLIDE PORT 1* softkey starts a measurement of the sliding load at test port 1.

For special features of the sliding-load measurement, see section 2.15.1.1.1, part b).

2.15.1.1.9 AutoKal Fundamental Calibration (ZVRL)

The *AUTOKAL FUNDAM'TAL* softkey calls the calibration test menu for a fundamental calibration of the AutoKal procedure.

It can only be used together with the option ZVR-B1 (AutoKal add-on module). See the description of the *AUTOKAL* softkey for instructions on connecting the AutoKal add-on module to the network analyzer.

The *AUTOKAL FUNDAM'TAL* menu does not differ from that of the unidirectional two-port calibration, which the fundamental calibration is based on (see description of the *ONE PATH TWO PORT* softkey). However, this procedure requires three sweeps to obtain all standards since the latter must be measured with three different switching states of the AutoKal add-on module.

The usual plausibility checks are carried out with measurement of the standards including check of the three switching states of the AutoKal add-on module with measurement of the through-connection (see *AUTOKAL* softkey). The 20-dB attenuator in the AutoKal add-on module is used for verification. After calculation of the correction values, the measured values of this attenuator are subject to system-error correction and compared to the rated values. A message is displayed in case of an error. Besides, the corrected values are stored and will be used later for verification of the transfer calibration.

While up to 4 different data sets can be active for the system error correction with decoupled display channels, only one current data set is available for the fundamental calibration. The *MEMORY RECALL* key is used to call a stored fundamental calibration, e.g., if required for another type of connector.

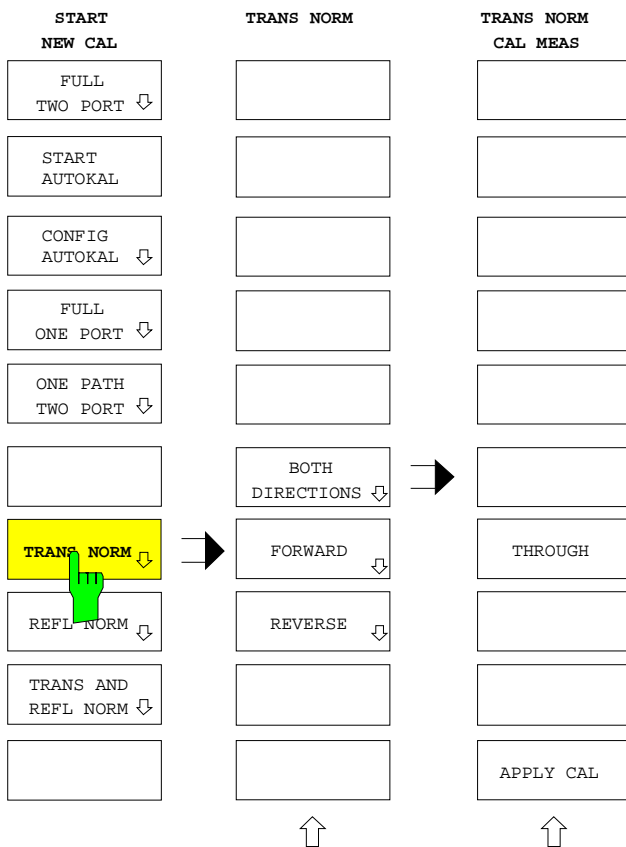
2.15.1.1.10 Normalization Calibration (ZVR, ZVRE, ZVC, ZVCE, ZVK, ZVM)

A normalization is the simplest form of system-error calibration since it requires the measurement of only one standard for each of the S-parameters to be calibrated.

The value measured for a given DUT at a given test point is divided by the measured value of the calibration standard at the same test point, i.e., the measurement is normalized. For transmission calibrations, a through-connection is used as standard, an open circuit is used for reflection calibrations. The frequency-dependent transmission attenuation of the network analyzer is eliminated by the normalization correction. Measurement errors due to low directivity or mismatch at the test port are not taken into account. Through-connection as well as open circuit are assumed to be ideal, i.e., with zero loss and length.

a) Transmission Normalization

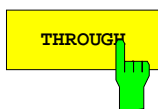
CAL CAL - START NEW CAL - XX - TRANS NORM submenu:



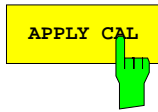
The *TRANS NORM* softkey calls the menu for transmission normalization measurements. The measurement signal can be normalized in both (*BOTH DIRECTIONS*) or in one direction (*FORWARD*, *REVERSE*, see Section 2.15.1.1.7, "Unidirectional Two-port Calibration").

- In the internal mode, a through-connection (*THROUGH*) between PORT 1 and PORT 2 is required as a standard.
- In the external mode, the signal paths given by the current definition of S_{21} and S_{12} (*RESPONSE MEAS - USER DEF'D S-PARAMS*) must be connected by a through-connection.

The S-parameters S_{21} and S_{12} are normalized by a common *THROUGH* measurement in both the internal and the external mode.



The *THROUGH* softkey starts the measurement of the through-connection between the test ports 1 and 2.

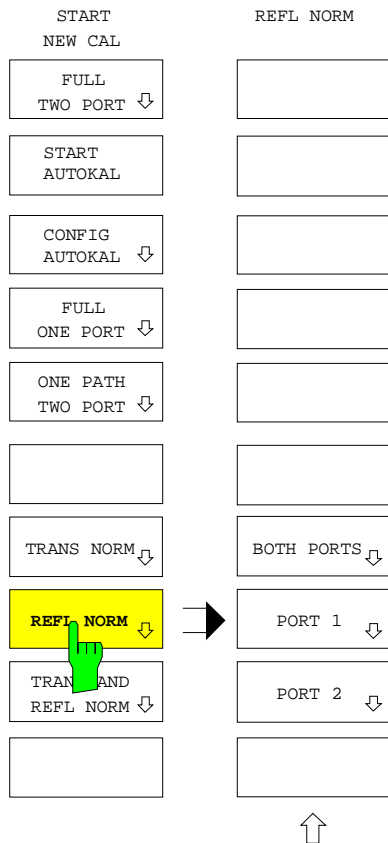


The *APPLY CAL* softkey terminates the measurement of the calibration standard and initiates calculation of the correction data.

This softkey can be activated only, if the required standards have at least been measured one time.

b) Reflection Normalization

CAL CAL - START NEW CAL - REFL NORM submenu:



The *REFL NORM* softkey starts a reflection normalization calibration measurement.

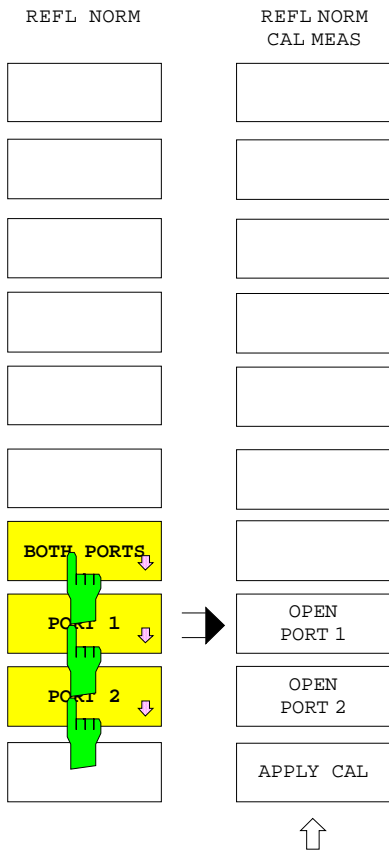
This procedure can be performed for

- test port 1 (*PORT 1*),
- test port 2 (*PORT 2*) or
- both ports (*BOTH PORTS*).

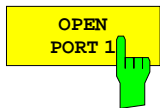
In the external mode, a reflection normalization can be performed at two different test ports (e. g. two external reflection coefficient bridges) as well. The definition of S_{11} and S_{22} must be adapted before to the external test setup via *RESPONSE MEAS - USER DEF'D S-PARAMS*.

The OPEN is used as standard providing total reflection. This is especially advantageous at low frequencies since the standard needs not be fitted physically. It is sufficient to leave the test port open.

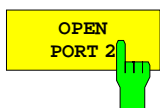
CAL CAL - START NEW CAL - REFL NORM - REFL NORM CAL MEAS submenu:



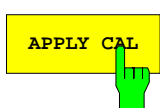
The PORT 1, PORT 2 and BOTH PORTS softkeys open the corresponding submenus for performing a reflection normalization at test port 1, test port 2 or at both test ports.



The *OPEN PORT 1* softkey starts the measurement of the open circuit at test port 1.



The *OPEN PORT 2* softkey starts the measurement of the open circuit at test port 2.

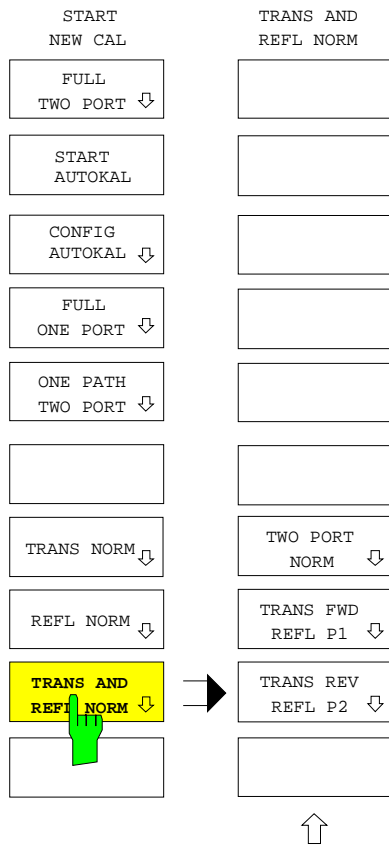


The *APPLY CAL* softkey terminates the measurement of the calibration standard and initiates calculation of the correction data.

This softkey can be activated only, if the corresponding open circuit has been measured at least one time.

c) Combined Transmission and Reflection Normalization

CAL CAL - START NEW CAL - TRANS AND REFL NORM submenu:



The *TRANS AND REFL NORM* softkey opens a menu for selecting a combined normalization calibration for transmission and reflection measurements.

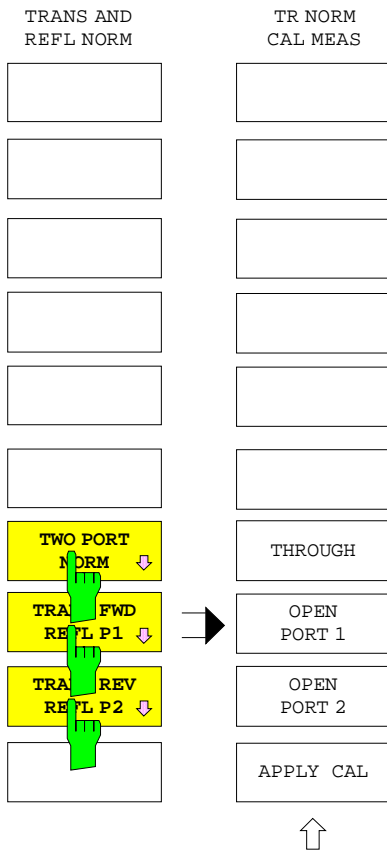
It is thus possible to perform

- bi-directional calibration for measuring the reflection at both test ports and transmission in both directions (*TWO PORT NORM*),
- calibration of the transmission in forward direction and the reflection at port 1 (*TRANS FWD REFL P1*),
- calibration of the transmission in reverse direction and the reflection at port 2 (*TRANS REV REFL P2*).

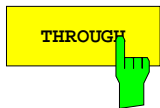
The combined normalization uses a through-connection and an open circuit as standards, too.

In the external mode, a reflection normalization requires, e. g., external reflection coefficient bridges. Prior to calibration, the definition of the S-parameters in question must be adapted to the external test setup via *RESPONSE MEAS - USER DEF'D S-PARAMS*. For the transmission calibration, the signal paths given by the current definition of S_{21} and S_{12} must be connected by a through-connection. In both the internal and the external mode, these two S-parameters are normalized by a common *THROUGH* measurement for a bi-directional calibration.

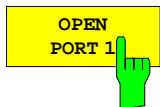
CAL CAL - START NEW CAL - TRANS AND REFL NORM - TR NORM CAL MEAS submenu:



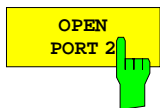
The TWO PORT NORM, TRANS FWD REFL P1 and TRANS REV REFL P2 softkeys open submenus for performing a combined as a bi-directional or unidirectional calibration in forward or reverse direction.



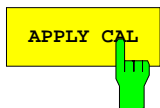
The *THROUGH* softkey starts the measurement of the through-connection between the test ports 1 and 2.



The *OPEN PORT 1* softkey starts the measurement of the open circuit at test port 1.



The *OPEN PORT 2* softkey starts the measurement of the open circuit at test port 2.



The *APPLY CAL* softkey terminates the measurement of the calibration standard and initiates calculation of the correction data.

This softkey can be activated only, if the required standards have been measured at least one time.

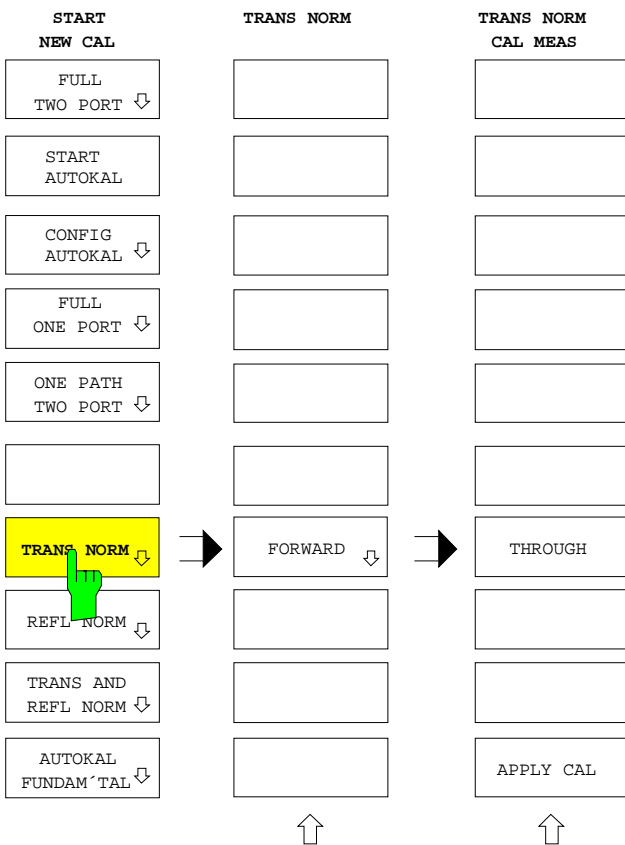
2.15.1.1.11 Normalization Calibration (ZVRL)

A normalization is the simplest form of system-error calibration since it requires the measurement of only one standard for each of the S-parameters to be calibrated.

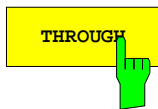
The value measured for a given DUT at a given test point is divided by the measured value of the calibration standard at the same test point, i.e., the measurement is normalized. For transmission calibrations, a through-connection is used as standard, an open circuit is used for reflection calibrations. The frequency-dependent transmission attenuation of the network analyzer is eliminated by the normalization correction. Measurement errors due to low directivity or mismatch at the test port are not taken into account. Through-connection as well as open circuit are assumed to be ideal, i.e., with zero loss and length.

a) Transmission Normalization

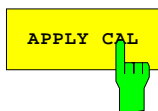
CAL CAL - START NEW CAL - FORWARD - TRANS NORM submenu:



- The *TRANS NORM* softkey calls the menu for performing a normalization calibration for transmission measurements.
- In the internal mode, a through-connection between PORT 1 and PORT 2 is required as standard (THROUGH).
- In the external mode, the signal path given by the current definition of S_{21} (*RESPONSE MEAS - USER DEF'D S-PARAMS*) must be connected by a through-connection.



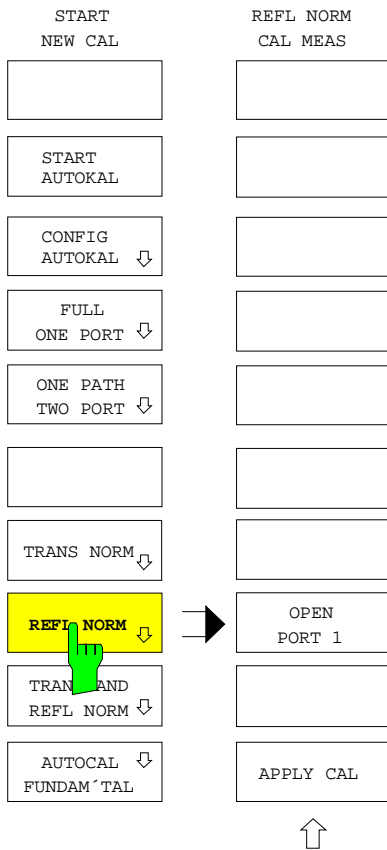
The *THROUGH* softkey starts the measurement of the through-connection between ports 1 and 2.



The *APPLY CAL* softkey terminates the measurement of the calibration standard and initiates calculation of the correction data.

This softkey can be activated only, if the required through-connection has been measured at least one time.

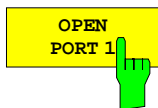
b) Reflection Normalization



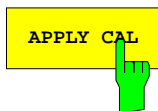
The *REFL NORM* softkey directly calls the menu for reflection normalization at test port 1.

In the external mode, a reflection normalization can be performed (e. g. at an external reflection coefficient bridge) as well. The definition of S_{11} must be adapted before to the external test setup via *RESPONSE MEAS - USER DEF'D S-PARAMS*.

The *OPEN* is used as standard providing total reflection. This is especially advantageous at low frequencies since the standard needs not be fitted physically. It is sufficient to leave the test port open.



The *OPEN PORT 1* softkey starts the measurement of the open circuit at test port 1.

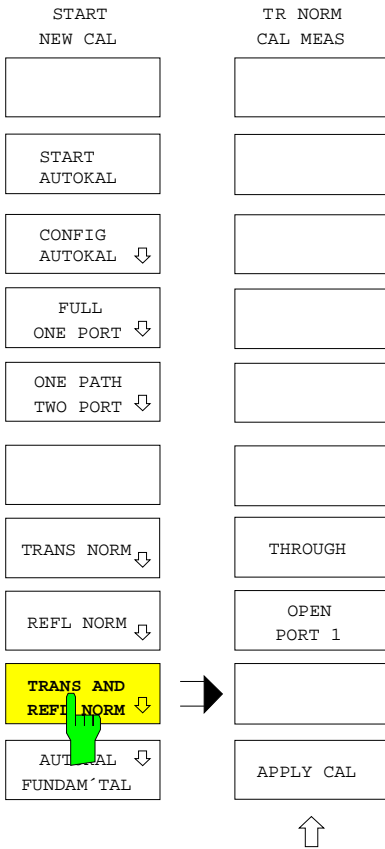


The *APPLY CAL* softkey terminates the measurement of the calibration standard and initiates calculation of the correction data.

This softkey can be activated only, if the required open circuit has been measured at least one time.

c) Combined Transmission and Reflection Normalization

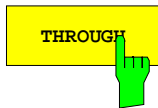
CAL CAL - START NEW CAL - TRANS AND REFL NORM submenu:



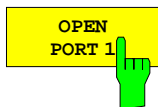
The *TRANS AND REFL NORM* softkey calls the menu for combined transmission and reflection normalization.

A reflection normalization is performed at test port 1 (for S_{11}), a transmission normalization from port 1 to port 2 (for S_{21}). The combined normalization uses the standards through-connection and open as well.

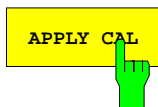
In the external mode, a reflection normalization requires, e. g., an external reflection coefficient bridge. Prior to calibration, the definition of the S-parameters S_{11} and S_{21} must be adapted to the external test setup via *RESPONSE MEAS - USER DEF'D S-PARAMS*. For the transmission calibration, the signal path given by the current definition of S_{21} must be connected by a through-connection.



The *THROUGH* softkey starts the measurement of the through-connection between the test ports 1 and 2.



The *OPEN PORT 1* softkey starts the measurement of the open circuit at test port 1.

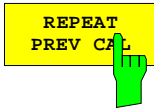


The *APPLY CAL* softkey terminates the measurement of the calibration standard and initiates calculation of the correction data.

This softkey can be activated only, if all standards required have been measured at least one time.

2.15.1.2 Auxiliary Functions for System Error Calibration

CAL CAL menu:



The softkey *REPEAT PREV CAL* repeats the calibration which corresponds to the system-error correction data of the active display channel.

The calibration test menu is displayed without any additional entries being made. The operating mode and sweep settings which are associated with the correction data set are restored when the calibration is started.

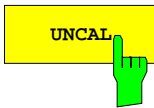


The *RESUME CAL* softkey continues a calibration in the calibration test menu which had been interrupted, e.g. in order to modify the scaling of the diagram

After resuming a calibration, only those standards, which have not yet been tested during a complete calibration sweep, must be measured.

Note:

- *Resuming an interrupted calibration with RESUME CAL is only possible as long as no setting parameters which are important for the validity of the calibration data already stored are changed. Such data are, e. g., switchover between the internal/external mode, reference-mixer mode, switch-on of a frequency-converting or non-linear operating mode, sweep mode, selective power measurement, location of the test points on the sweep axis and attenuation.*
- *Switch-off or reset of the instrument using the STATUS PRESET key causes loss of all measured data of the standards.*

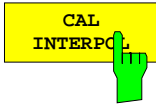


With the *UNCAL* softkey switched on, the system error correction recorded by the user is switched off and vice versa. Thus, like the *POWER UNCAL* softkey, *UNCAL* has an inverse functionality. The system error correction is a parameter that can be coupled. For decoupled channels, it is effective only in the active display channel.

The enhancement label CA(x) signals an active system error correction. The possible versions of this enhancement label are described in section 2.3.1.1.

Some additional setting parameters of the network analyzer which are relevant for the correction are stored together with the system error correction data. When system error correction is switched on, these parameters are restored to ensure consistency of correction data and device setting. For example, the frequency sweep mode and the test point grid are restored at the time of calibration and an active frequency conversion is deactivated.

Even if *UNCAL* is switched on (i.e. user calibration is switched off), a system error correction with a factory-set correction data record will be carried out. Independent of the switching state of the *CAL INTERPOL* softkey, interpolation between these correction data points is performed if they do not coincide with the test points of the current sweep.



The *CAL INTERPOL* softkey interpolates the correction data between the test points of the calibration run. The enhancement label *CAI* indicates calibration with interpolation (*UNCAL* is switched off and *CAL INTERPOL* is switched on).

Interpolation allows a system error correction even if the test points of the current sweep do not coincide with the points of the current calibration.

Note: *An interpolation is possible only if the interpolation grid is linear and all test points lie inside the calibrated range. There is no extrapolation (except when a group delay measurement with frequency aperture is performed, see the RESPONSE FORMAT - FREQUENCY APERTURE softkey).*

If *CAL INTERPOL* is switched on and the sweep range is modified such that the test points get outside the calibration data range, the network analyzer switches to the factory-set correction data set (*UNCAL* is switched on). The same applies, if *CAL INTERPOL* is switched off and the sweep is changed such that the calibration points and test points do no longer coincide. Interpolation is possible in all sweep modes.

2.15.1.3 Characteristics of Calibration Standards

The *MODIFY CAL KIT* softkey opens a menu for the management of calibration kits for the individual connector families.

Exact knowledge of the calibration standards is a prerequisite for a accurate system-error calibration. More precisely, the calibration is based on the knowledge of those S-parameters of the standards which are assumed to be known for the applied calibration method. These S-parameters are derived from physical models which contain one or more parameters (such as the electrical length) depending on the type of standard.

In addition to these physical parameters, there are three description fields for each standard listing the assignment of the standard and further information for the user.

1. Standard type: The type depends on the kind of standard (e.g. open circuit, short circuit, through-connection) and the sex of the connectors. Example: *THROUGH (MF)* denotes a through-connection with a plug at one and a socket at the other port. The standard type determines the physical description model and therefore the parameters which can be edited. Up to four individual standards with different parameters can be defined for one standard type. Only one of them can be selected (active) at one time.
2. Calibration kit (*KIT*): A calibration kit is an assembly of real, physical calibration standards. Calibration kits are supplied by Rohde & Schwarz as an accessory for network analyzers. The parameters of the standards in a calibration kit are stored on a floppy disk which can be read in via the *INSTALL NEW KIT* softkey. Kits for coaxial connector families usually do not contain all possible standard types of these families but only a subset comprising the types which are most frequently used in coaxial technology. Calibration kits can be user-defined as well. Using the *ACTIVATE KIT* softkey, the standards of a calibration kit can be selected altogether by just one keystroke.
3. Serial number (*SERIAL #*): All standards of a calibration kit are factory-labeled with the same serial number so they can be assigned unambiguously to this kit. The serial number helps to avoid confusion between standards of the same type from different calibration kits which might have different physical parameters.

CAL CAL - CAL KITS submenu:

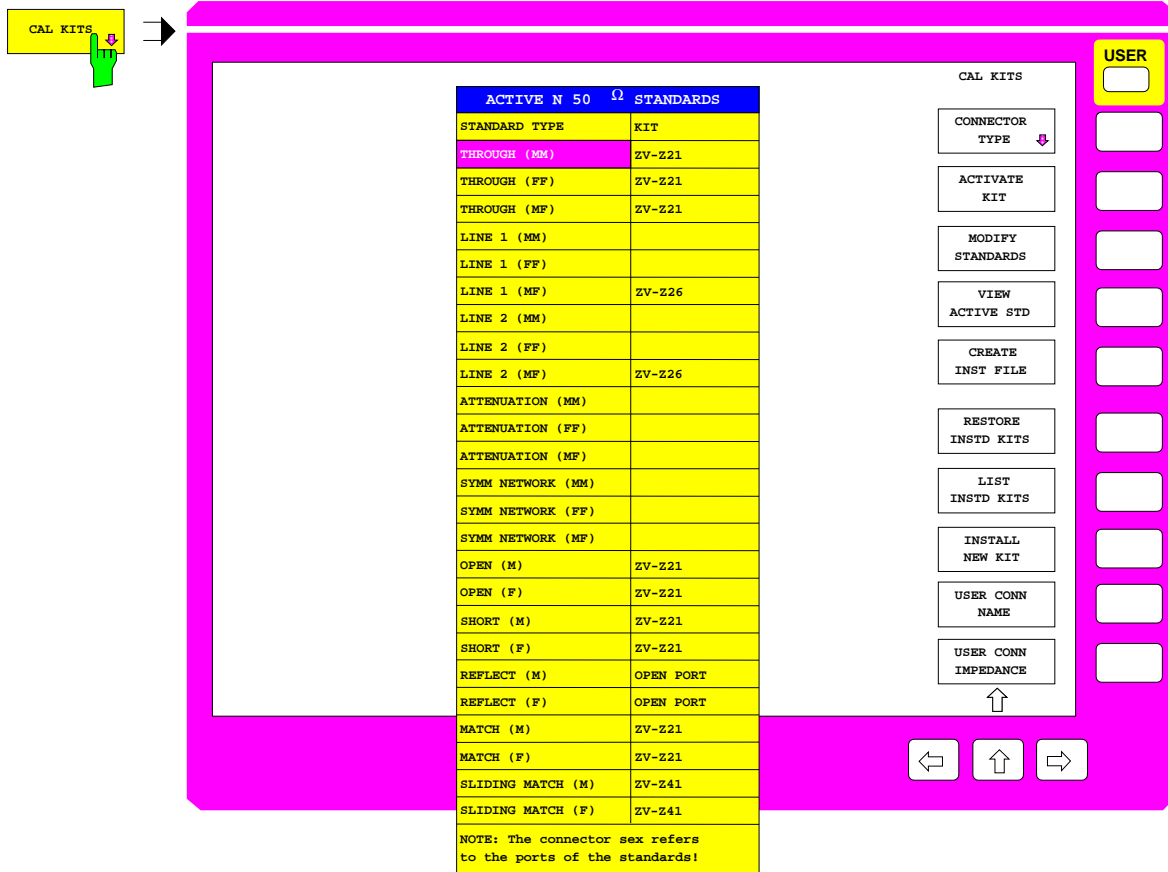


Fig. 2-40 Selecting the connector families

After pressing the *CAL KITS* softkey, the *ACTIVE XX STANDARDS* selection table is displayed, where *XX* denotes the connector family selected. By default, the connector family of the test set ports is selected. The table gives an overview of the active standards of the connector family:

- The *STANDARD TYPE* column lists all standard types which are required for the calibration procedures of the respective type of instrument.
- The *KIT* column indicates to which calibration kit the currently selected physical standard belongs. By default, for standard types contained in the calibration kits offered by Rohde & Schwarz, the designation of the corresponding kit is also displayed. Although typical parameter values are pre-defined for these standards, the individual parameters for each calibration kit, which are supplied on a floppy, should be read in for the sake of maximum accuracy (see *INSTALL NEW KIT* softkey). The predefined standards without calibration kit assignment are assumed to be ideal.

The cursor can be used to select the standard type the softkeys *MODIFY STANDARDS* and *VIEW ACTIVE STD* refer to.

For polarized connector families, three types exist for each two-port standard, namely male/male (MM), female/female (FF), and male/female (MF). One-port standards are provided as male (M) and female (F). For non-polarized connectors, such as PC 7, all standards are contained only once in the table.

If a calibration method requires to measure two standards with the same polarity simultaneously, their characteristics are assumed to be identical. This applies, e.g., to the TOM-X calibration method if the *OPEN BOTH PORTS* measurement is performed.

The following types of standards are provided for the various types of network analyzers. Due to the restricted calibration facilities of the ZVRE, ZVCE and ZVRL compared to the ZVR, ZVC, ZVK and ZVM, a reduced set of standards is required only.

Table 2-5 Standard types for the network analyzers

| ZVR, ZVC, ZVK, ZVM | ZVRE, ZVCE, ZVRL | |
|--------------------|------------------|---|
| THROUGH | THROUGH | through-connection |
| LINE 1 | | line 1 for TRL calibration procedure |
| LINE 2 | | line 2 for TRL calibration procedure |
| ATTENUATION | | unknown matched attenuator |
| SYMMETRIC NETWORK | | unknown mismatched reflection-symmetric two-port standard |
| OPEN | OPEN | open circuit |
| SHORT | SHORT | short circuit |
| OFFSET SHORT | OFFSET SHORT | additional short circuit for waveguide calibration |
| REFLECT | | unknown mismatched one-port standard |
| MATCH | MATCH | broadband termination |
| SLIDING MATCH | SLIDING MATCH | sliding load |

CAL CAL - MODIFY CAL KIT - SELECT KIT submenu:

| CAL KITS | CONNECTOR TYPE |
|---------------------|-----------------------|
| CONNECTOR TYPE | N 50 Ω |
| ACTIVATE KIT | N 75 Ω |
| MODIFY STANDARDS | |
| VIEW ACTIVE STD | PC 7 |
| | |
| RESTORE INSTD KITS | SMA |
| LIST INSTD KITS | PC 3.5 |
| INSTALL NEW KIT | |
| USER CONN NAME | SEXLESS USR CONN 1 |
| USER CONN IMPEDANCE | USR CONN 2 |

The *CONNECTOR TYPE* softkey calls a menu for selecting the connector family shown in the *ACTIVE XX STANDARDS* table.

The type and order of the connectors shown in this menu are different for the different models of the ZVx family. The connector types used for the instrument test ports always come at the uppermost position. This is also the default setting.

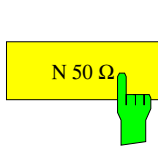
The following connector families are provided:

- N 50 Ω,
- N 75 Ω,
- PC 7,
- SMA,
- PC 3.5,
- 2.92 mm.

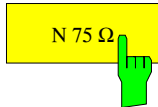
In addition two connector families can be arbitrarily defined, namely:

- SEXLESS USR CONN 1
- USR CONN 2

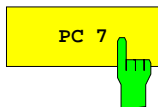
Only the two user-defined connector families can be configured for waveguide calibration.



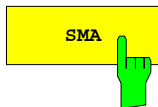
The *N 50 Ω* softkey displays the table *ACTIVE N 50 Ω STANDARD*.



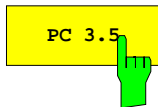
The *N 75 Ω* softkey displays the table *ACTIVE N 75 Ω STANDARDS*.



The *PC 7* softkey displays the table *ACTIVE PC 7 STANDARDS*.



The *SMA* softkey displays the table *ACTIVE SMA STANDARDS*.



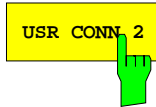
The *PC 3.5* softkey displays the table *ACTIVE PC 3.5 STANDARDS*.



The *SEXLESS USR CONN 1* softkey displays the table *ACTIVE USER CONN 1 STANDARDS*. The connector family *SEXLESS USR CONN 1* which can be user-defined is not polarized (similar to PC 7) and particularly suited for non-coaxial cable systems such as microstrip.

The two user-defined connector families *SEXLESS USR CONN 1* and *USR CONN 2* can also be used for waveguide calibration (refer to *WAVEGUIDE* softkey description). As waveguides are as a rule not polarized, *SEXLESS USR CONN 1* is to be preferred to *USR CONN 2*.

The name of this connector family (*USR CONN 1* by default) can be modified via the *USER CONN NAME* softkey.



The *USR CONN 2* softkey displays the table *ACTIVE USER CONN 2 STANDARDS*. Unlike *SEXLESS USR CONN 1*, this user-defined connector family is polarized and therefore suited for the coaxial connectors that are not pre-defined in the *CONNECTOR TYPE* menu. The connector family *USR CONN 2* can also be used for waveguide calibration.

The name of this connector family (*USR CONN 2* by default) can be modified via the *USER CONN NAME* softkey.

CAL CAL - CAL KITS submenu:



The *ACTIVATE KIT* softkey displays the selection table *ACTIVATE KIT*.

| ACTIVATE KIT |
|--------------|
| OPEN PORT |
| ZCAN |
| √ ZV-Z21 |
| ZV-Z26 |
| ZV-Z28 |
| ZV-Z41 |
| |
| |

This table lists all calibration kit names defined for the connector family currently selected. All standards including the ones that are currently not active are considered.

The cursor keys move the cursor within the table. A kit is selected via the units prefix key. A checkmark displayed for a short time indicates that a kit has been selected.

All standards with the selected kit name are set active.

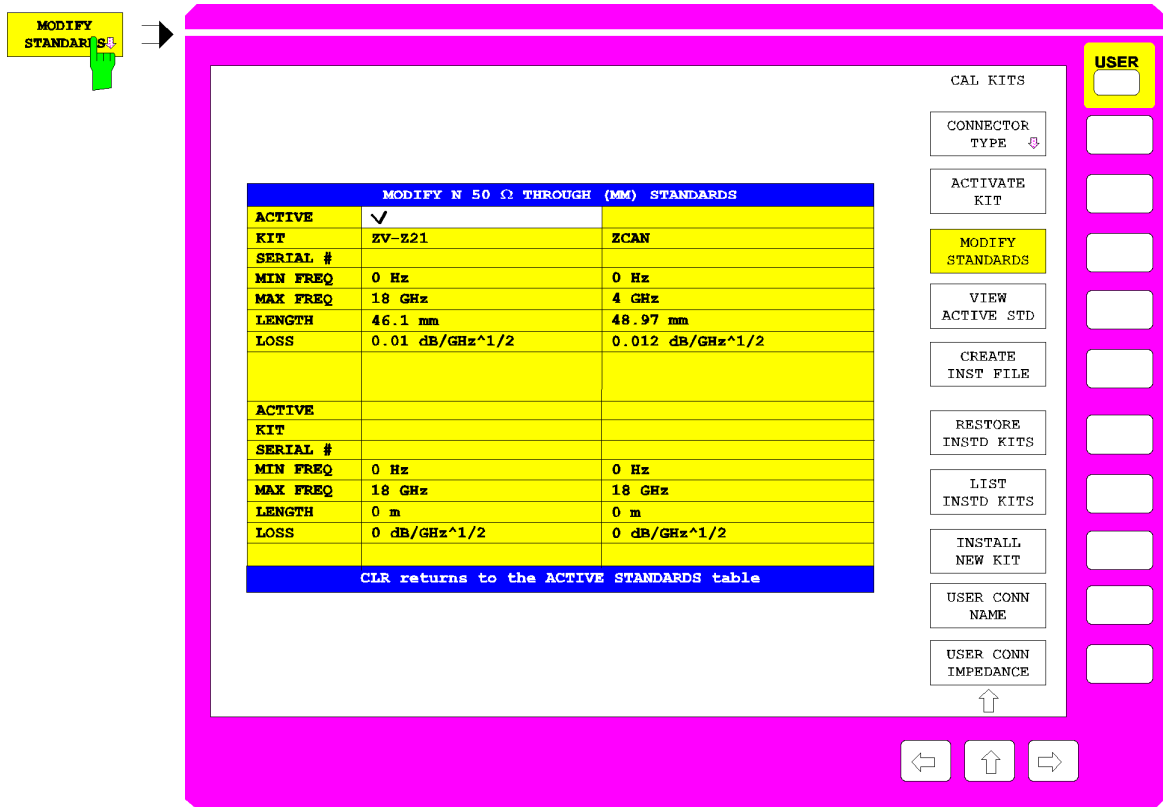


Fig. 2-41 Modifying the standards

The *MODIFY STANDARDS* softkey calls the *MODIFY XX YY STANDARDS* table.

In the four quadrants of this table, the parameters of the four individual standards of a single type are displayed. The type is selected in the *ACTIVE XX STANDARDS* table. The parameters describe the physical model of this standard type. All displayed parameters can be edited, even if the corresponding standard is currently not set. The upper five parameters are available for all standard types, the remaining ones depend on the kind of model applied.

If a parameter in this table is changed, an asterisk (*) is appended to the calibration kit name (*KIT*) of the corresponding standard.

ACTIVE Standard active

A checkmark in the table row *ACTIVE* indicates which one of the individual standards is currently active. If a definite standard type, e.g. an OPEN (F), is measured in a calibration, the calibration algorithm uses the parameters of the active individual standard of this type.

KIT Designation of the calibration kit

The calibration kit name can be entered here. It comprises a maximum of 10 characters and appears in the *ACTIVE XX STANDARDS* table if the standard activated.

Some softkey functions access the calibration kit name as well. The standards with the same kit name can be activated altogether via *ACTIVATE KIT*. The softkey *RESTORE INSTD KITS* restores the original parameters of the calibration data sets which were installed from floppy disk. *LIST INSTD KITS* list all calibration data of a connector type installed from floppy disk.

An asterisk (*) as the last character of the kit name indicates that the preset values or the values installed from floppy of one or several parameters of the corresponding individual standard were changed. If an attempt is made to enter a calibration kit name which is already present twice (e.g. once in the original form and once labeled as user-defined, i.e. with an asterisk), an exclamation mark and an asterisk will be appended to the name.

SERIAL # Serial number of the standard

Besides the calibration kit name, the serial number (max. 15-digit) is a further individual attribute for the standards. It is used especially to distinguish standards from calibration kits of the same type. For the calibration kits offered by Rohde & Schwarz, the same serial number is used throughout the whole kit. This number is assigned to every single standard when the kit is installed. Standards purchased later as spare parts have another serial number of course.

MIN FREQ – minimum frequency of the standard

The sliding load, e.g., is a standard with minimum frequency since it can be used above 2 GHz only.

MAX FREQ – maximum frequency of the standard

For each standard, a maximum frequency is defined. The physical model described by the subsequent parameters is valid up to this maximum frequency.

LENGTH – electrical length of the standard

The electrical length of the standard can be entered for *OPEN*, *SHORT*, *OFFSET SHORT*, *REFLECT*, *THROUGH*, *LINE 1* and *LINE 2* and *SYMMETRIC NETWORK*. The default unit of the electrical length is mm. For *REFLECT* and *SYMMETRIC NETWORK*, the electrical length must be specified only if it causes a phase deviation of more than 90° from the assumed approximation (*APPROX* field) in the frequency range to be calibrated.

Note: *For one-port standards, only the single length (length offset) is to be entered, too.*

LOSS – losses

The losses of the standard are entered in this field. It is assumed that they are resistive line losses whose value (in dB) increases proportionally with the root of the frequency due to the skin effect. The attenuation is thus entered in units of dB/GHz. Losses are indicated only for *OPEN*, *SHORT*, *OFFSET SHORT*, *THROUGH* and *LINE*. For one-port standards, the total loss, i.e., the return loss must be entered.

C0... C3 – polynomial coefficients for parasitic capacitance

For *OPEN*, as well as for *REFLECT* and *SYMMETRIC NETWORK* with *APPROX = OPEN* selected, the parasitic capacitance at the open end of the line can be described by a third-order frequency polynomial. C0 denotes the constant part, C1 to C3 the polynomial coefficients of the corresponding powers of the frequency. The unit of the coefficient Cn is thus fF/GHzⁿ (n=0,..., 3).

For *REFLECT* and *SYMMETRIC NETWORK*, specification of the coefficients is required only if the latter cause a phase deviation of more than 90° from the assumed *OPEN* approximation in the frequency range to be calibrated.

L0... L3 – polynomial coefficients for parasitic inductance

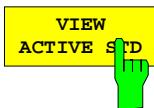
For *OPEN*, as well as for *REFLECT* and *SYMMETRIC NETWORK* with *APPROX = SHORT* selected, the parasitic inductance can be described by a third-order frequency polynomial. L0 denotes the constant part, L1 to L3 the polynomial coefficients of the corresponding powers of the frequency. The unit of the coefficient Ln is thus pH/GHzⁿ (n=0,..., 3).

For *REFLECT* and *SYMMETRIC NETWORK*, specification of the coefficients is required only if the latter cause a phase deviation of more than 90° from the assumed *SHORT* approximation in the frequency range to be calibrated.

APPROX – approximate modeling

When a reflection standard (*REFLECT*) or a reflection-symmetric network (*SYMMETRIC NETWORK*) is selected, it must be indicated, whether the unknown reflection coefficient can be approximately modeled as a short or an open circuit.

This information is required only to exclude a sign ambiguity when the reflection coefficient is determined implicitly. If the length offset or parasitic reactances cause a rotation of the phase of the unknown reflection coefficient of more than 90° with respect to the approximate phase (0° for *APPROX = OPEN*, 180° for *SHORT*), these parameters must be specified as well.



The *VIEW ACTIVE STD* softkey displays the *ACTIVE XX YY* table, where XX denotes the connector family and YY the standard type, e.g. ACTIVE N 50 Ω OPEN (F).

This table can not be edited. It shows the parameters of the currently active individual standard of the type that was selected in the *ACTIVE XX STANDARDS* table. If a certain standard type, e.g. an OPEN (F) is measured during a calibration, the calibration algorithm uses the parameters of the active individual standard of this type. For a description of the table rows refer to softkey *MODIFY STANDARDS*.



The *CREATE INST FILE* softkey creates an installation file for a calibration kit. This function is useful, e.g., if an updated installation file for the entire calibration kit is needed after exchange of an individual calibration standard, or if calibration kit data entered via *MODIFY STANDARDS* are to be transferred to other instruments. The *SELECT KIT* table shows all calibration kits of the connector type currently selected.

Once the desired kit has been selected and confirmed via the ENTER key, an input field for the path and name of the installation file is displayed. The default entries correspond to the current path for *SAVE / EDIT* and the name of the selected calibration kit with the extension *.chk. Upon entering the name the installation file is written to the specified directory.

To create an updated installation file for the entire calibration kit after exchanging an individual calibration standard, the file supplied with the replacement standard is installed first. During installation, only the data pertaining to this standard are overwritten in the corresponding calibration kit file. Afterwards, the desired file for the entire kit can be created via *CREATE INST FILE*.

To create an installation file for calibration kits from other manufacturers, the data describing the different standards is entered via *MODIFY STANDARDS*; the entire data is assigned to the same calibration kit. Afterwards, *CREATE INST FILE* is used to create the installation file.



The *RESTORE INSTD KITS* softkey resets the parameters of all standards to the values defined in the instrument firmware. Exceptions are calibration kits installed from floppy disk (or from another storage medium). Those are reset to their original state after the installation.

The softkey also activates the same standards which were active in the preset state. Besides that, the default values of the name and reference impedance of the connector families which can be user-defined (*SEXLESS USR CONN 1* and *USR CONN 2*) are restored. This function is used to cancel all user entries, especially the ones made by mistake.



The *LIST INSTD KITS* softkey displays the *INSTALLED CAL KITS* table.

This table can not be edited. It shows all calibration kits which were installed from floppy disk (or from another storage medium) or which were generated by modifying an originally installed calibration kit. Preinstalled kits or kits generated by modification of an originally preinstalled kit are not listed.

| INSTALLED CAL KITS | | |
|--------------------|--------|------------|
| CONNECTOR | KIT | SERIAL # |
| N50Ω | ZV-Z21 | 123456/001 |

CONNECTOR Connector family

The CONNECTOR column shows the connector family of the calibration kit.

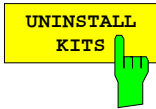
The meaning of the two columns *KIT* and *SERIAL #* is as explained under softkey *MODIFY STANDARDS*. If the standards of a kit have different serial numbers *VARIOUS* is indicated in the *SERIAL #* column.



The *INSTALL NEW KIT* softkey allows one to install calibration kits from a floppy disk or another storage medium.

If a floppy containing a single calibration kit file (this applies to all floppies provided with the calibration kits from Rohde & Schwarz) is inserted into the disk drive a message window indicating the connector type and the kit designation is displayed after a short time. In this window, installation of the new kit must be confirmed. The calibration kit is read in and a new message indicates that the installation was successfully completed.

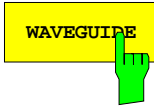
If several calibration kit files (file extension *.ck) are stored on the floppy, or if no floppy is in the disk drive, the input field *EDIT CAL KIT PATH* is invoked where the path and file name of the desired calibration kit file can be entered. The further procedure is as described above.



The *UNINSTALL KITS* softkey allows the user to delete the user-installed calibration kits for a connector family.

User-installed calibration kits are meant to include calibration kits read in from a storage medium by means of the *INSTALL NEW KIT* function. They do not mean to include the preinstalled kits contained in the instrument firmware. Please note that this function deletes **all** user-installed calibration kits for the connector family selected in the *CONNECTOR TYPE* menu (e.g. PC 3.5).

To preserve particular user-installed calibration kits, they must first be saved by means of the *CREATE INST FILE* function.



The connector families *SEXLESS USR CONN 1* and *USR CONN 2* can also be configured for waveguide calibration by means of the *WAVEGUIDE* softkey. If this softkey is activated, the instrument takes into account the nonlinear relationship between the phase of the S-parameters and the frequency, which prevails in waveguides. This effect is also known as dispersion.

At the frequency f , the transmission phase φ , e.g. of a *THROUGH* or a *LINE* standard of the length l , is not governed by the relationship

$$\varphi = \frac{2\pi f}{c} \cdot l \quad \text{but by}$$

$$\varphi = \frac{2\pi f}{c} \cdot l \cdot \sqrt{1 - \left(\frac{f_c}{f}\right)^2},$$

where f_c is the cutoff frequency of the waveguide mode used (normally the basic mode).

When the *WAVEGUIDE* softkey is activated, the *CUTOFF FREQUENCY* softkey for entering the cutoff frequency is available too.

The *OPEN* standard is unsuitable with waveguide calibration because in this case it does not provide total reflection but radiates like an antenna. Therefore, if the *WAVEGUIDE* softkey is switched on, the *OPEN* standards are replaced by *SHORTS* (for standards table see *CAL CAL - CAL KITS* submenu). The latter must have a length offset different from the existing *SHORTS* and are for this reason referred to as *OFFSET SHORTS*. At frequencies at which the length difference between the *SHORT* and the *OFFSET SHORT* equals a multiple of $\lambda/2$, singularities occur since the shorts have identical reflection coefficients in this case. To avoid this, the length offset of the *OFFSET SHORT* should be selected to obtain a length difference of $\lambda/4$ between the *SHORT* and the *OFFSET SHORT* in the middle of the measurement frequency range. The associated reflection coefficients are then exactly opposite in phase. As the frequency range is normally not larger than the single-mode range of the waveguide, i.e. max. one octave, singularities do not occur at the range limits either if the length offset is selected as described.

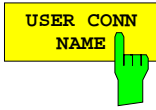
The *SHORT* of a waveguide calibration kit is usually in the form of a plate, i.e. it has no electrical length. The effects of attenuation and leakage inductance can be neglected in practice. The *OFFSET SHORT* is in most cases realized by a *SHORT* to which a piece of line ($\lambda/4$) (shim) is added. The electrical length of this added line is entered as the length offset for the *OFFSET SHORT*. The effects of attenuation and leakage inductance can usually also be neglected for the *OFFSET SHORT*.

Note: The $\lambda/4$ line can also be used as a LINE standard, for example for TRL calibration.



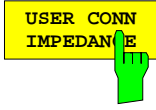
The *CUTOFF FREQUENCY* softkey opens an input field for entering the cutoff frequency for the waveguide mode for which calibration is to be made. This is usually the basic mode of the waveguide.

The waveguide mode cannot propagate below the cutoff frequency, which means that system error correction is not possible below this point. The cutoff frequency, therefore, represents the minimum start frequency for measurement and calibration. If the start frequency of the calibration range is lower than the entered cutoff frequency (e.g. after a *PRESET*), an error message is output.



The *USER CONN NAME* softkey activates the entry of a name comprising up to 11 characters for the connector families *SEXLESS USR CONN 1* and *USR CONN 2*. The name refers to the family selected in the *CONNECTOR TYPE* menu. In the title of the tables *ACTIVE XX STANDARDS*, *MODIFY XX YY STANDARDS* and *ACTIVE XX YY*, it replaces the character string *XX*. The name of the corresponding softkeys in the *CONNECTOR TYPE* submenu, however, can not be overwritten.

The default names are *USER CONN 1* and *USER CONN 2*.



The *USER CONN IMPEDANCE* softkey activates the entry of the reference impedance for the connector *SEXLESS USR CONN 1* or *USR CONN 2*. The impedance refers to the family selected in the *CONNECTOR TYPE* menu. The default value is 50 Ω.

Note: Only a constant reference impedance can be entered via this softkey. While the characteristic impedance of a waveguide is highly frequency-dependent, the conversion of reflection coefficients to impedances or the calculation of Z parameters in the waveguide are irrelevant in practice.

2.15.1.4 Power Calibration (Option ZVR-B7)

When measuring ratios formed from wave parameters, such as S-parameters, the absolute value of the generator level cancels out. For other test parameters such as compression and intercept points, it is, however, important to know the absolute generator and receive levels at the ports. Corresponding to those levels, the ZVR allows to perform either a generator or a receiver power calibration. Power calibration is possible for frequency sweep and controlled via the menu of the *START NEW POWER CAL* softkey.

Generator power calibration:

Purpose: A generator power calibration is carried out in order to keep the level of a wave propagating towards the DUT in an arbitrary reference plane (typically the input of the DUT) independent of the frequency at a constant value selected by the user.

This eliminates the frequency response of the attenuation introduced by the test setup between signal generator and the reference plane. As the test setup itself can cause arbitrary gain or attenuation, the desired level at the reference plane is not restricted to the usual setting range.

A generator power calibration can be performed for both the internal signal source of the network analyzer and the two external sources.

Carrying out: The calibration is performed with a power meter. Its power sensor can be fitted either directly to the calibrating reference plane or to any other test point whose level is proportional to the level of the reflected wave at the reference plane. The power meter is remote-controlled via the IEC SYSTEM BUS (lower IEC/IEEE connector on rear panel).

For each point of the sweep,

1. the desired nominal level is set with the factory-set power correction of NWA being active. This corresponds to a level setting via the *SWEEP SOURCE – POWER* softkey,
2. the level at the reference plane or at the test point is measured with the power meter,
3. the difference between actual and rated value is calculated, ie correction value,
4. the power of the source to be calibrated is modified by this correction value provided that this is compatible with the electronic setting range (depending on the type of instrument and the measurement mode).
5. step 2 to 4 is repeated if several iterations are desired, For external generators the test run at the first sweep point is different: in this case, the power is increased from the smallest settable level step by step until the rated level is attained. The setting value thus found is then used as start level for the second sweep point. Then, step 2 to 5 is repeated. The corresponding setting value thus found is also the iteration start for the next test point.

Attenuator: If a generator attenuator is available, its attenuation should be selected before the calibration is started such that the level range that can be set electronically covers the frequency response to be corrected.

Power correction with an offset: If the desired value is changed after a generator power calibration and if the calibration is not repeated, the correction values are referred to this new value, ie the offset between the original and the new desired value is taken into account. The same holds

- if the attenuation of the corresponding generator attenuator is changed after a power calibration of the waves a_1 or a_2 ,
- if the mode is changed from frequency to power sweep,
- if a compression or intercept point measurement is activated.

Note: *Power correction with an offset impairs the accuracy of the desired level because of possible deviations from linearity in the generator level and, eventually, also in the signal path. The maximum offset is given by the setting range of the respective source.*

Change of measured quantity: If a new measured quantity is selected while generator power calibration is active, it is checked whether the stimulus signal for the new quantity is identical with the generator wave currently being calibrated. For example, to determine S_{11} and S_{21} , the DUT has to be stimulated with wave a_1 (leaving out of account that for full two-port calibration two stimulus signals are needed), whereas for S_{12} and S_{22} wave a_2 is needed as a stimulus. If the new stimulus signal differs from the generator wave currently being calibrated, a message is output informing the user that the generator signal is not calibrated.

Receiver power calibration:

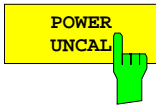
Purpose: A receiver power calibration is carried out in order to detect signals received by the network analyzer with respect to an arbitrary plane (typically the output of the DUT) with their correct level. The corresponding power correction is effective for the measurement of wave quantities and ratios formed from these quantities (menus *RESPONSE MEAS - INPUT* and *RATIO*).

Carrying out: For a receiver power calibration, a signal with a level known from a previously performed generator power calibration is fed into the reference plane to be calibrated. The generator power calibration can be either factory-set or performed by the user.

- For a power calibration of the waves a_1 and a_2 , the analyzer independently performs a receive level calibration of the associated reference channel at each test point and immediately after the generator power calibration. As the reference channels are carried inside the instrument, no external cable connections need to be fitted.
- For a calibration of the measurement channels (waves b_1 and b_2 as well as a_1 at the a_1 EXT IN socket), however, the instrument must be connected externally such that a wave with a known level (a_1 or a_2 according to generator power calibration) is fed into the receive channel to be calibrated.

Power correction with an offset: Similar to the generator power correction, also the receiver power correction takes into account an offset if the receiver attenuator setting is changed.

Note: *The level uncertainty after a generator power calibration basically depends on the measurement uncertainty of the power meter as well as on multiple reflections caused by a possible generator output and power meter mismatch. For power meters that can take a frequency-dependent calibration factor into account (eg all power meters from Rohde & Schwarz), the frequency is communicated via IEC/IEEE bus, which reduces measurement uncertainty. The uncertainty of the receiver power calibration is at least as large as that of the fundamental generator power calibration, and an additional uncertainty arises from the multiple reflections between mismatched generator output and receiver input. To obtain an accurate receiver power calibration, it is therefore recommended not to rely on the factory power calibration on the test ports but to perform a very accurate generator power calibration at a suitable reference plane (eg at the end of a cable).*



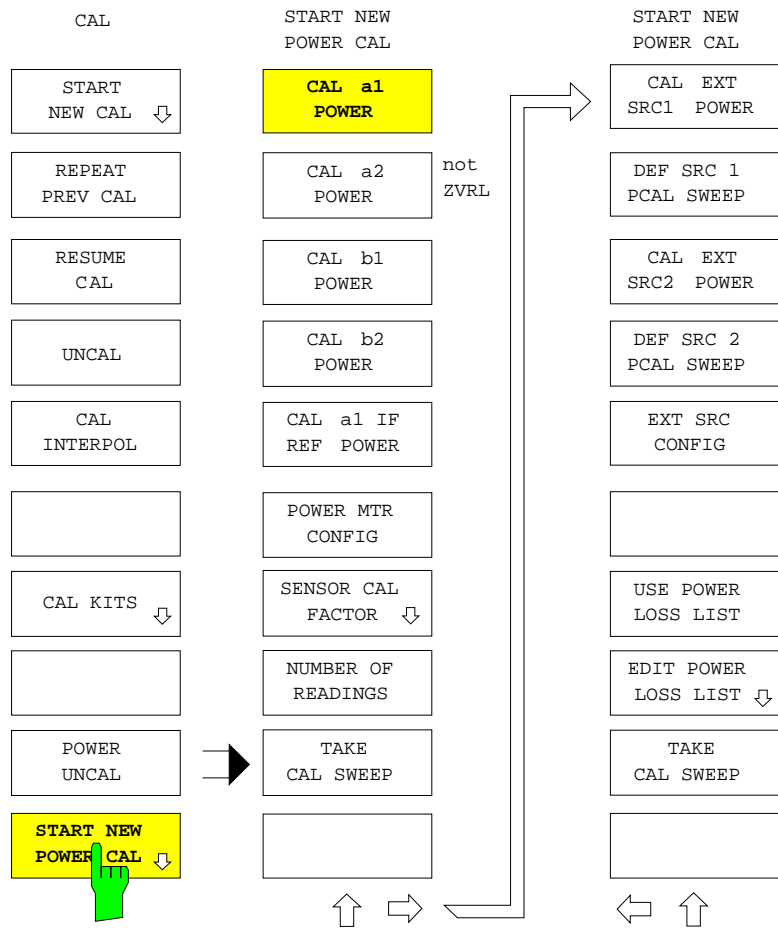
With the *POWER UNCAL* softkey switched on, the power correction recorded by the user is switched off and vice versa. Thus, *POWER UNCAL* like the *UNCAL* softkey has an inverse functionality. The power correction is a parameter that can be coupled. For decoupled channels it is effective only in the active display channel.

The enhancement label PC(x) signals an active power correction. The possible versions of this enhancement label are described in the *START NEW POWER* menu. The currently power-calibrated wave quantities are listed under the enhancement label.

Some additional setting parameters of the network analyzer which are relevant for the correction are stored together with power correction data. When power correction is switched on, these parameters are restored to ensure consistency of correction data and device setting. For example, the frequency sweep mode and the test point grid are restored at the time of calibration, and an active frequency conversion is deactivated.

Even if *POWER UNCAL* is switched on, ie user calibration is switched off a power correction with a factory-set correction data record will be carried out. The level measured for a wave parameter is then with reference to the connector active in the corresponding operating mode. For the internal mode (*SYSTEM MODE – EXTERNAL* switched off) with instruments of the ZVR or ZVC family, these are test ports PORT 1 and PORT 2, for external mode connectors OUTPUT a1, INPUT b1 and INPUT b2. With ZVK and ZVM, the receiver power correction for wave b_1 refers to PORT 1 or INPUT b1 depending on the *SYSTEM MODE – INPUTS – PORT 1 INPUT b1* softkey setting, the same applies to b_2 analogously.

CAL CAL - START NEW POWER CAL submenu:



The *START NEW POWER CAL* menu contains the following functions:

- Using a generator calibration for the outgoing waves, one of the wave parameters a_1 or a_2 can be corrected to a frequency constant level at an arbitrary reference plane (*CAL a1 POWER* and *CAL a2 POWER*, the latter softkey not for ZVRL). In addition, a receiver power calibration for the corresponding reference channel is performed.
- A receiver power calibration can be performed for the incoming wave parameters b_1 and b_2 (*b1 POWER CAL* and *b2 POWER CAL*). If the option ZVR-B6 (Reference Channel Ports) is fitted, the reference channel a_1 for the wave fed to the *a1 EXT IN* socket can be calibrated as well (*a1 IF REF POWER CAL*).
- The power meter can be configured (*POWER MTR CONFIG*).
- If the power meter does not automatically take into account the frequency-dependent calibration factor of the power sensor used, one of two editable calibration factor lists can be chosen (*SENSOR CAL FACTOR*).
- If higher accuracy of the generator power calibration is required, the evaluation of correction values can be iterated. The number of iterations (*NUMBER OF READINGS*) can be selected.
- After selecting the wave parameter to be calibrated, the calibration sweep can be started (*TAKE CAL SWEEP*).
- If the option ZVR-B4 (Frequency-Converting Measurements) or ZVR-B5 (Nonlinear Measurements) is fitted, a generator power calibration can be performed for the two external sources (*CAL EXT SRC 1 POWER* and *EXT SRC 2 POWER*). This power calibration is performed analogous to the calibration of the internal generator. However, the frequency points can be chosen independent of the test point grid of the network analyzer. If the sensor is not directly connected to the reference plane and the level difference between the reference plane and the test point is known as a function of the frequency, this difference can be entered into a list and thus be taken into account (*USE POWER LOSS LIST, EDIT POWER LOSS LIST*).

Power setting in the *SWEEP SOURCE* menu:

If a generator power correction of the internal source is active, the level can no longer be set via the *SWEEP SOURCE - POWER* and *SLOPE* softkeys. One of the *CAL a1 POWER* or *CAL a2 POWER* softkeys in the same menu can then be pressed instead to set the rated level. These softkeys have the same function as those in the *CAL CAL – START NEW POWER CAL* menu.

For the power calibration of external sources the *CAL EXT SRC1/2 POWER* softkeys in the right side menu of *SWEEP SOURCE* menu are available, *EXT SRC 1/2 POWER* and *EXT SRC 1/2 SLOPE* continue to be inhibited.

Power calibration of several waves:

A power calibration can be successively applied to several wave parameters. To this end, the following must be avoided:

- switchover between internal and external mode,
- change of the test point grid.

If one of these settings is changed and a new power calibration for the wave parameter is performed, the calibration data for all other waves become irreversibly invalid.

After a calibration sweep has been carried out successfully, the correction data are stored in a file so that they are still available after switching off and on the instrument (this does not hold if *SRC PCAL EACH SWEEP* is selected).

Validity of correction data: If the test point grid is changed, the correction values are interpolated over the frequency provided the new frequency points lie inside the calibrated range. If not, the power calibration is switched off. The correction values for the fixed frequency in the level or time sweep are also interpolated, if possible.

Note: *The generator and receive frequency range are also influenced by switching on and off or modifying a frequency-converting or non-linear measurement mode. All power-calibrated wave parameters have to be inside the calibrated frequency range as correction will otherwise be switched off. The power correction of external generators is specially checked for validity and is switched off, if required. The frequency range of power calibration should be selected so as to cover the minimum and maximum frequency at the connectors of the network analyzer. The power correction of external generators is checked for validity independently of the internal waves.*

Enhancement labels: An enhancement label indicates which one of the waves a_1 , a_2 , b_1 and b_2 is currently corrected:

| | |
|------------|---|
| PC | Power correction of at least one wave quantity or one external generator |
| PCI | Interpolation of correction values as a function of frequency |
| PCO | An offset relative to the original correction data is taken into account |
| PC? | During a generator power calibration of the internal signal source, for at least one test point either the nominal value was not attained or the offset was so large that the setting range of the source was exceeded. |

All wave quantities which are currently power-calibrated (see section 2.3.1.1, Diagram Area) are indicated under PC(x), except for the external generators. Status message E1/2 is displayed even if valid correction data is available for the relevant generator, which, however, is not used for the current measurement. E1/2 goes off if the relevant generator is currently operating in a range which is not or is only partially covered by the correction data.

If only one receiver power correction is activated for wave quantities a_1 or a_2 , this is indicated by status message a1l or a2l. This occurs for instance when wave a_1 is calibrated and then a_2 . Since the two outgoing waves cannot be simultaneously generator-power-calibrated, only the receiver power calibration of the reference channel has an effect in relation to a_1 .

The power calibration cannot be started if:

- the sweep is not performed over frequency in the current setting,
- a frequency-converting or non-linear measurement is active

However, power correction can itself be activated in these cases.

Power calibration and segmented sweep: Power calibration is possible in a segmented frequency-point grid (*SWEEP SWEEP – DEF SWEEP SEGMENTS* or *SEG SWEEP*) and can be active. Note the following:

The nominal value of a generator-power calibration is also entered via *CAL CAL – START NEW POWER CAL – CAL a1 / a2 POWER* when the frequency axis is segmented. The power values for the various segments in the SRC PWR column of the *SWEEP SEGMENTS* table have no relevance for generator-power calibration. If power calibration is active, the entry POWER CAL is displayed in the SRC PWR column.

If only one receiver-power calibration is active, the segment-specific generator power values in the *SWEEP SEGMENTS* table still apply.

If a receiver-power calibration is performed during the segmented sweep, the reference generator wave should first be calibrated with *CAL CAL – START NEW POWER CAL – CAL a1 / a2 POWER*. If not, the selected generator power values at least must be identical in all segments in order to obtain a useful result.

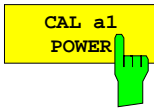
Segmented, linear and logarithmic sweeps are interpolation-compatible. This means, for example, that the power correction values are interpolated when the calibration interpolation-point grid is segmented and the measurement-point grid is linear and vice versa. However, extrapolation is never performed outside the interpolation-point grid. If there are wide gaps between segments, the interpolation error may not be negligible in the gaps.

In the case of frequency-converting measurements, power calibration with a segmented interpolation-point grid is particularly effective if a narrow frequency band is shifted by a large offset. If the range between the minimum and the maximum frequency at the network analyzer connectors is covered by a linear grid, many interpolation points may occur in the unused gaps between frequencies. Conversely, the grid in the bands of interest only provides a coarse partition, which means that measurement accuracy is not optimal. This can be avoided by means of a calibration over a segmented sweep, which only takes into account the frequency ranges relevant for the measurement. The following procedure is recommended:

1. Definition of a segment list with typically two segments, one corresponding to the unconverted frequency band and the other to the converted band (*SWEEP SWEEP – DEF SWEEP SEGMENTS*). It is, of course, possible to define several segments - for example, when several bands are to be converted at the same time. The number of test points in each segment can be selected as required.
2. Activation of the segmented sweep (*SWEEP SWEEP – SEG SWEEP*)
3. Power calibration of all relevant wave quantities over the segmented sweep (*CAL CAL – START NEW POWER CAL*)
4. Only if the frequency-converting measurement is to be performed in the *ARBITRARY* mode: Call of the definition menu (*SYSTEM MODE – FREQUENCY CONVERTS – DEF ARBITRARY*)
5. Setting the start and stop frequency of the linear or log sweep over which the frequency-converting measurement is to be performed (*STIMULUS START / STOP*). The sweep range of the fundamental is set for the *ARBITRARY* mode. Caution: This setting has no effect on the sweep trace in the measurement diagram since the segmented sweep is not yet active.
6. Switchover to linear or log measurement-point grid (*SWEEP SWEEP – LIN / LOG SWEEP*). This should not be done prior to setting the sweep range. Otherwise, power correction would be deactivated if the start or stop frequency that has been set is outside the segmented sweep. Enhancement label PC becomes PCI since interpolation has to be performed with the new measurement-point grid.

7. Only if the frequency-converting measurement is to be performed in the *MIXER* or *ARBITRARY* mode: Configuration of the frequency-converting measurement (*SYSTEM MODE – FREQUENCY CONVERTS – DEF MIXER MEAS / DEF ARBITRARY*)
8. Activation of the frequency-converting measurement (*SYSTEM MODE – FREQUENCY CONVERTS – SECOND / THIRD HARMONIC, MIXER MEAS, ARBITRARY*)

CAL CAL - START NEW POWER CAL submenu:



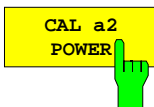
The *CAL a1 POWER* softkey selects power calibration of the wave parameter a_1 . This comprises a generator power calibration of the internal source and – if *SRC PCAL EACH SWEEP* is switched off – a receiver power calibration of the reference channel for forward measurement. In the preset state this softkey is switched on. An entry field for the desired level at the reference plane of calibration is opened.

In the internal mode the reference plane for a_1 lies in a signal path connected to the PORT 1 socket, in the external mode the reference plane is connected to OUTPUT a_1 .

The calibration sweep is started by activating the *TAKE CAL SWEEP* softkey. The measured quantity a_1 is selected automatically. A generator power correction is possible only for one of the two waves a_1 or a_2 . If the power calibration of a wave parameter is started, any correction data for the other wave become invalid. Instead, the correction data of the calibrated wave are also applied to the uncalibrated wave. A receiver power correction of the other channel is however kept. If the test set is unbalanced (eg instrument with only one generator attenuator), the level of the uncalibrated generator wave can considerably deviate from the nominal value of the calibrated one.

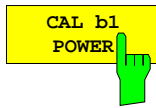
Note: *For the ZVR and ZVC families the following applies: If the option ZVR-B6 (Reference Channel Ports) is fitted and the REFERENCE MIXER softkey is switched on, a correct receiver power calibration for a_1 is achieved only if the generator-power-calibrated reference wave a_1 is fed to the a_1 EXT IN rear-panel socket. This receiver power calibration need not be performed together with the generator power calibration of a_1 but can be made in a separate step (see a_1 IF REF POWER CAL softkey). Either the reference plane for generator power calibration is connected directly to a_1 EXT IN, then a_1 is measured with the correct power as referred to this connector. Or, a_1 EXT OUT is connected to a_1 EXT IN via a line, then the quantity a_1 is a measure for the outgoing wave at PORT 1. The two alternatives exist also for ZVK and ZVM, where the paths of both reference waves can be opened and receiver power calibration performed (connectors R1 / R2 CHANNEL OUT / IN).*

In the CAL a_1 POWER entry field, the current attenuation values of the generator step attenuators are displayed.



The *CAL a2 POWER* softkey selects power calibration of wave a_2 . This is analogous to the calibration of a_1 (*CAL a1 POWER*). The *CAL a2 POWER* softkey is not available for model ZVRL.

The reference plane for a_2 lies in a signal path connected to PORT 2 so that the softkey operates in the internal mode only.

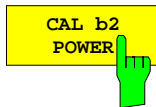


The *CAL b1 POWER* softkey selects receiver power calibration of the wave parameter b_1 .

A generator with a known level is required. If wave quantity b_1 is received via test PORT 1, a_2 serves as a known reference wave. However, if b_1 is received via INPUT b_1 socket (ie external mode set on ZVRx and UVCx or INPUT b_1 activated on ZVK/ZVM), a_1 is used. To reduce measurement uncertainty, the reference wave should first undergo a generator power calibration.

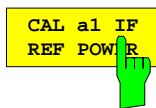
- If b_1 is received via PORT 1, the reference plane for b_1 has to be connected to the reference plane of the generator power calibration of a_2 (in a signal path connected to PORT 2) via a low-loss and low-reflection cable.
- Otherwise, INPUT 1 socket has to be connected to the reference plane of the generator power calibration of a_1 (connected to OUTPUT a_1 or PORT 1 on ZVK/ZVM) via a low-loss and low-reflection cable.

The calibration sweep is started by activating the *TAKE CAL SWEEP* softkey. Measured quantity b_1 is automatically selected .



The *CAL b2 POWER* softkey selects receiver power calibration of wave parameter b_2 . This is analogous to the calibration of b_1 (*CAL b1 POWER*).

As known generator wave, a_1 is used. The reference plane for b_2 lies in a signal path connected to PORT 2 or INPUT b_2 .



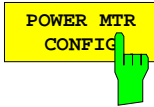
The *CAL a1 IF REF POWER* softkey selects receiver power calibration of the wave parameter a_1 via the rear-panel socket a_1 EXT IN.

This function requires the option ZVR-B6 (Reference Channel Ports) to be fitted and the *MODE - REFERENCE MIXER* to be switched on. The receive calibration via a_1 EXT IN is useful especially for frequency-converting measurements where a converted reference signal is received in channel a_1 .

The generator-power-calibrated wave a_1 is used as known calibration signal. Calibration can be performed in the internal and external mode. Depending on whether the known generator wave a_1 is directly fed to the a_1 EXT IN socket or the a_1 EXT OUT and a_1 EXT IN sockets are connected, the measured level for a_1 refers to a_1 EXT IN socket or to test PORT 1.

With the *REFERENCE MIXER* softkey activated, the receiver power correction data for a_1 are independent of those recorded with the softkey deactivated. Thus, two correction data records are available. The *REFERENCE MIXER* softkey is used to switch over between these two data records.

The calibration sweep is started by activating the *TAKE CAL SWEEP* softkey. Measured quantity a_1 is selected automatically.



The *POWER MTR CONFIG* softkey calls a table for configuration of the power meter.

Power meters NRVS, NRVD and NRV from Rohde & Schwarz as well as 437 B and 438 A from Hewlett-Packard are supported.

| POWER METER CONFIG | | | |
|--------------------|-----------|-----------|-------------------|
| TYPE | GPIB ADDR | AUTO ZERO | SENSOR CAL FACTOR |
| NRVD | 4 | ✓ | DATA FROM SENSOR |

When editing the TYPE field, the selection table PWR MTR TYPE is displayed:

| PWR MTR TYPE |
|--------------|
| HP437B |
| HP438A |
| NRV |
| ✓NRVD |
| NRVS |

In the GPIB ADDR field, the IEC/IEEE-bus address of the power meter is entered.

When the AUTO ZERO field is switched on, automatic zeroing of the power meter is performed before each sweep. If the power meter supports this function it is recommended to activate AUTO ZERO. This is recommended for particularly small desired levels.

The *SENSOR CAL FACTOR* field cannot be edited. It indicates the way in which the frequency-dependent calibration factor of the power sensor is taken into account. Power meters from Rohde & Schwarz take the correction factor automatically into account. In this case, entry DATA FROM SENSOR is displayed. For other units, a list comprising the interpolation test points of the calibration factor over the frequency can be entered in the *SENSOR CAL FACTOR* submenu. This submenu also helps to determine which of the two lists is to be used. Depending on the setting of the *CAL CAL – START NEW POWER CAL – SENSOR CAL FACTOR - USE SENSOR A B* softkey, the message FACTOR LIST A or B (see *SENSOR CAL FACTOR* menu) is displayed in the *SENSOR CAL FACTOR* field.



Fig. 2-42 Entry of a frequency-dependent calibration factor

The *SENSOR CAL FACTOR* softkey calls a submenu for entry of the frequency-dependent calibration factor for the power sensor used.

Due to mismatch, losses and changes in sensitivity of the power sensor, the power measurement is subject to frequency-dependent errors. The calibration factor of a sensor describes which percentage of the power transmitted to the sensor is actually detected and indicated by the test instrument. Some power meters, such as the units of the NRV family from R&S, read the calibration factor from a memory in the sensor and thus take it into account automatically. For other instruments (eg HP 436 A), the calibration factor must be set manually at the instrument but is only valid for one frequency. In this case, a table of calibration factors over frequency which is taken into account for the generator power calibration can be entered into the analyzer via the *SENSOR CAL FACTOR* menu. A calibration factor of 100 % is to be set at the power meter.

The calibration factor can be entered for two different power sensors and for up to 20 frequency interpolation points. Depending on the setting of the *USE SENSOR A B* softkey, either the table *SENSOR A CAL FACTOR LIST* or *SENSOR B CAL FACTOR LIST* is displayed. The second line contains a name for identification of the power sensor which can be defined via the *SENSOR LABEL* softkey. The individual softkeys are listed below, sorted automatically in ascending order of the frequencies. Next to the test point number, there are two columns which can be edited:

| | |
|------------|--|
| FREQUENCY | frequency value of the interpolation point |
| CAL FACTOR | associated calibration factor in percent |

Linear interpolation is applied between the points of the active calibration coefficient list. Outside the given frequency range the calibration factors of the lower and upper limit frequency apply. No correction is made in the presetting of the table, ie the calibration factor is generally set to 100%. If the list contains only one point, the *FREQUENCY* field cannot be edited and *CAL FACTOR* applies to all frequencies.

When attempting to close the list with several points available at the same frequency, a corresponding message is displayed. Either the redundant points can be deleted automatically or you can return to the edit mode.

CAL CAL - START NEW POWER CAL - SENSOR CAL FACTOR submenu:



The *DEL ALL POINTS* softkey deletes all interpolation points from the selected calibration-factor list.



The *DEL ACTIVE POINT* softkey deletes the active interpolation point, ie the one which the cursor is positioned to.

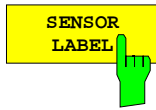


The *INS NEW POINT* softkey inserts a new interpolation point following the active one.

The default values of the new line are adopted by the active interpolation point.

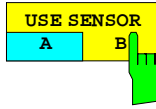


The *GOTO POINT #* softkey renders the indicated interpolation point active, ie it shifts the cursor of the calibration-factor list vertically into the respective line. The position of the cursor in the column does not change.



A name for the selected power sensor (A or B) of up to 12 characters can be entered via the *SENSOR LABEL* softkey .

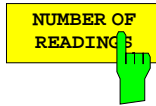
This name is displayed in the second line of the calibration-factor list.



The *USE SENSOR A B* softkey is used to switch between the calibration factors of power sensors A and B.

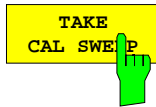
The switchover refers to the table displayed and to the data set used with power calibration.

CAL CAL - START NEW POWER CAL submenu:



The number of iteration steps to be made for generator power calibration at each test point can be entered via the *NUMBER OF READINGS* softkey. The default value is one.

An iteration step consists of first measuring the actual level at the reference port or at the test point with the power meter. Then, the difference between the desired and the actual level is determined and the power of the generator to be calibrated is increased or decreased by this difference provided that this is compatible with the allowed setting range. The smaller the previous deviation of the actual level from the desired value, the higher the level accuracy which can be obtained in one step. It is thus advisable to set the level at the test point via the corresponding softkey in the *SWEEP SOURCE* menu before the calibration is started such that the difference to the desired value is minimized.



The *TAKE CAL SWEEP* softkey starts a single power calibration sweep.

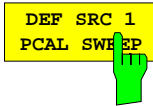
The sweep can be aborted via the *ABORT* field. If the desired value is not attained at least at one sweep point, a message will be issued and the enhancement label *PC?* will be displayed.



The *CAL EXT SRC 1 POWER* softkey selects generator power calibration of the external signal source 1. An entry field for the desired level is opened simultaneously.

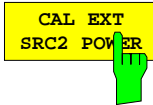
The frequency range of this calibration is defined via *DEF SRC 1 PCAL SWEEP*. Only the frequency of this generator and not that of the internal wave parameters is decisive for the validity of the level correction data of an external generator.

The *TAKE CAL SWEEP* softkey starts the calibration sweep. The measured quantity is not changed.



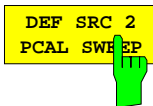
The *DEF SRC 1 PCAL SWEEP* softkey calls the table SRC 1 POWER CAL SWEEP used to define the frequency points for the generator power calibration of the external source 1.

| SRC 1 POWER CAL SWEEP | |
|-----------------------|--------|
| START | 10 MHz |
| STOP | 3 GHz |
| NUM OF PTS | 100 |
| SWEEP GRID | LIN |



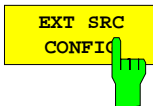
The *CAL EXT SRC 2 POWER* softkey selects generator power calibration of the external signal source 2.

This is analogous to the calibration of the external source 1 (*CAL EXT SRC 1 POWER* softkey).



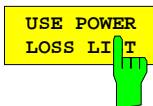
The *DEF SRC 2 PCAL SWEEP* softkey calls the table SRC 2 POWER CAL SWEEP used to define the frequency points for the generator power calibration of the external source 2.

This is analogous to the definition of the frequency points for the external source 1 (*DEF SRC 1 PCAL SWEEP* softkey)



The *EXT SRC CONFIG* softkey calls the *EXT SOURCES CONFIG* table.

For a description of this table refer to the *SYSTEM MODE - FREQUENCY CONVERS - DEF MIXER MEAS* softkey.



The *USE POWER LOSS LIST* softkey switches on the power calibration using a known, frequency-dependent power loss list.

Sometimes it is not possible to connect the power sensor directly at the reference plane for the generator power calibration, eg if the reference port is not accessible. If, however, the level difference between the reference port and the power test point is known and stored in the power loss list, a generator power calibration can be performed nevertheless. The measured power is then increased by the power loss value from the list before comparison with the desired value. Eventually, interpolation over the frequency is carried out. The points of the power loss list are entered in the *EDIT POWER LOSS LIST* menu.

The *EDIT POWER LOSS LIST* softkey calls a submenu for entering the frequency-dependent loss between the reference plane and the power test point.

Up to 20 interpolation points can be entered into the POWER LOSS LIST table. The entries are sorted in ascending order of the frequencies. Next to the test point number, there are two columns which can be edited:

FREQUENCY – frequency value of the interpolation point

POWER LOSS – associated loss in dB

Linear interpolation is applied between the interpolation points of the loss list. Outside the given frequency range the power loss values of the lower and upper limit frequency apply. In its preset state, the table is empty and cannot be used. If the list only contains one point, the FREQUENCY field cannot be edited. POWER LOSS then applies to all frequencies.

When attempting to close the list with several points available at the same frequency, a corresponding message is displayed. Either the redundant points can be deleted automatically or you can return to the edit mode.

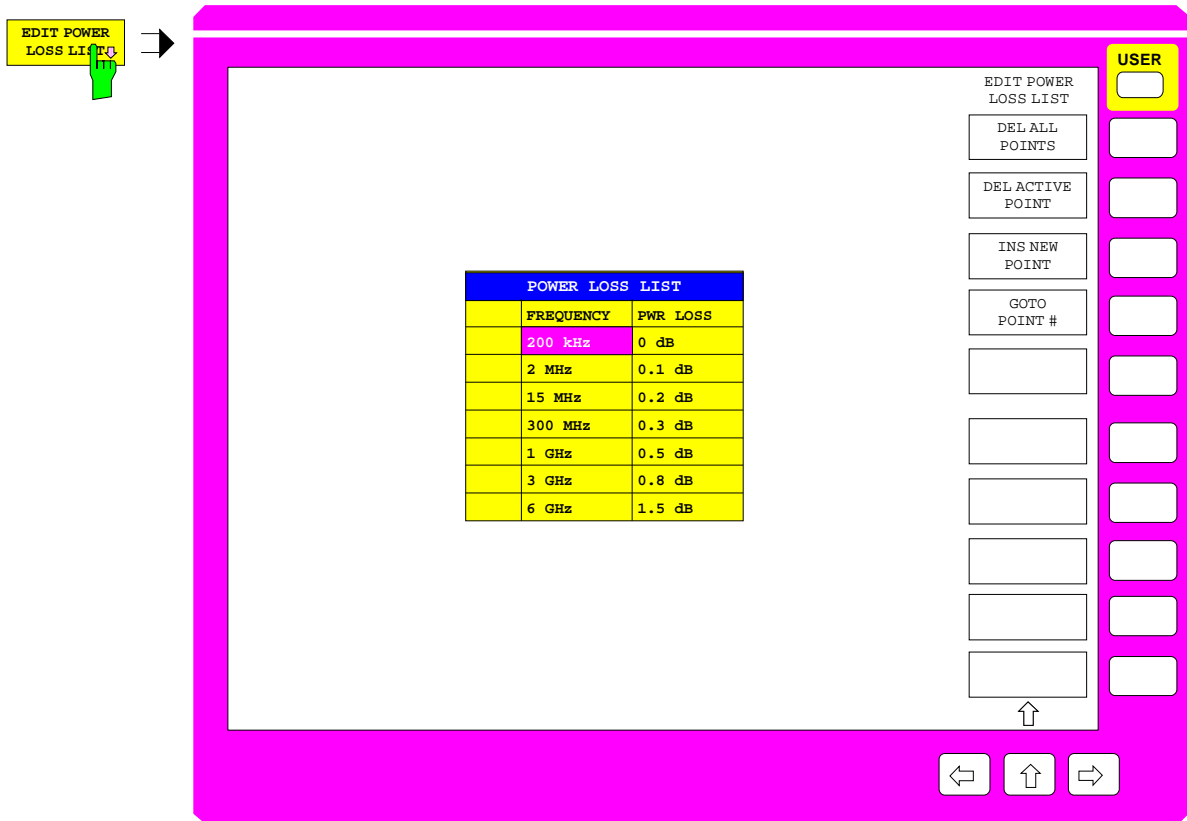


Fig. 2-43 Entry of a frequency-dependent loss



The *DEL ALL POINTS* softkey deletes all interpolation points from the power loss list.



The *DEL ACTIVE POINT* softkey deletes the active interpolation point, ie the one which the cursor of the loss list is positioned to.

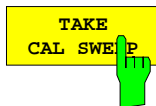


The *INS NEW POINT* softkey inserts a new interpolation point following the active interpolation point.

The default values of the new line are adopted by the active interpolation point.



The *GOTO POINT #* softkey renders the indicated interpolation point active, ie it shifts the cursor of the loss list vertically into the respective line. The position of the cursor in the column does not change.



The *TAKE CAL SWEEP* softkey is also available in the side menu.

2.15.2 Entry of Offset Parameters – *OFFSET* Key

The system error correction which is accessed via the *CAL* key is completed by the *OFFSET* key. Offset parameters are useful, eg

- if a DUT is connected unseparably to a cable and the scattering parameters of the DUT are to be measured without the phase rotation of the cable which is proportional to the frequency.
- if a DUT cannot be connected directly to the calibrated test port but the loss and phase rotation between the test port and the desired reference plane is known and has to be eliminated.

Only S-parameters can have an offset but not wave parameters and quotients of the *RESPONSE MEAS – INPUT and RATIO* menus. It is to be noted that offset parameters are always with reference to one of the two test ports and not to the currently selected S-parameter. This simplifies the most important application of offset parameters, ie the shift into the reference plane. A length offset does not have to be defined for each individual S-parameter but, like a piece of conductor, automatically influences all S-parameters concerned. An offset for PORT 1 influences S_{11} , S_{12} and S_{21} , an offset for PORT 2 influences S_{12} , S_{21} and S_{22} .

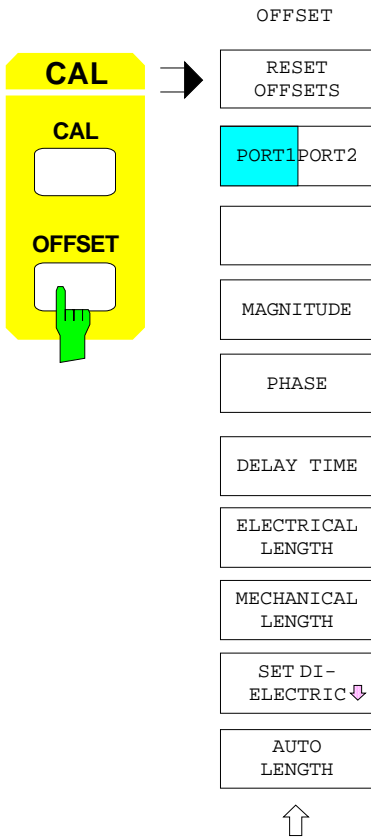
Please note that the resulting phase rotation of reflection parameters (S_{11} , S_{22}) with given offset length is twice as high as that of transmission parameters (S_{12} , S_{21}). If, say at a test frequency of 300 MHz, the reference plane is shifted by 250 mm ($\lambda / 4$), the phase indicator of S_{21} is turned by 90° whereas that of S_{11} is turned by 180° .

A positive offset length at a test port corresponds to a shift of the reference plane towards the DUT and causes a positive phase rotation of the reflection coefficient and transmission coefficient. A negative offset length has the opposite effect.

In addition to the position of the reference plane also the amplitude or phase offset for the S-parameters concerned can be defined for each test port.

Offsets are considered after system error correction but prior to conversion and formatting. They should therefore not be confused with the addition of a constant after formatting (*RESPONSE SCALE - ADD CONSTANT* softkey).

Offset parameter setting is global, ie applies to all channels irrespective of the coupling state. If at least one offset parameter is different from 0, the enhancement label OFS is displayed.

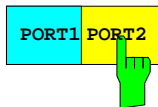


The *OFFSET* menu comprises the following functions

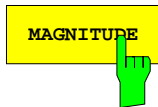
- All offset parameters can be reset to 0 (*RESET OFFSETS*).
- The entered value is valid for one of the two test ports (*PORT1/PORT2*).
- An individual amplitude (*MAGNITUDE*), phase (*PHASE*) and length offset can be defined for each test port.
- A length offset can be entered as a delay time (*DELAY TIME*),
- Electrical length (*ELECTRICAL LENGTH*),
- Mechanical length (*MECHANICAL LENGTH*).
- When entering a mechanical length, a dielectric can be set for conversion into the effective electrical length (*SET DIELECTRIC*).
- In the frequency sweep mode, the length offset can be calculated automatically such that the phase rotation of the active S-parameter in the sweep range is minimal (*AUTO LENGTH*).



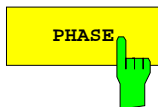
The *RESET OFFSETS* softkey resets the amplitude, phase and length offsets of both test ports to zero.



The *PORT1/PORT2* softkey defines which test port the entered offset parameters refer to. In the external mode, the above-mentioned allocation between offset parameters and S-parameters applies.



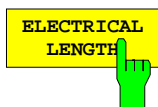
The *MAGNITUDE* softkey activates the entry of an amplitude offset (in dB) for the S-parameters concerned by the selected test port.



The *PHASE* softkey activates the entry of a phase offset (in degrees) for the S-parameters concerned by the selected test port.

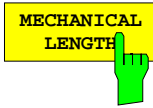


The *DELAY TIME* softkey activates the entry of a length offset for the selected test port as a delay time. The entry value is coupled with that of softkeys *ELECTRICAL LENGTH* and *MECHANICAL LENGTH*.



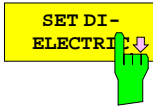
The *ELECTRICAL LENGTH* softkey activates the entry of a length offset for the selected test port as an electrical length. The entry value is coupled with that of softkeys *DELAY TIME* and *MECHANICAL LENGTH*.

The electrical length is interpreted as length of a piece of conductor with a dielectric of permittivity ϵ_0 (i.e. $\epsilon_r = 1$).



The *MECHANICAL LENGTH* softkey activates the entry of a length offset for the selected test port as mechanical length. The entry value is coupled with that of softkeys *DELAY TIME* and *ELECTRICAL LENGTH*.

The mechanical length is interpreted as a piece of conductor with a dielectric the permittivity ϵ_r of which is defined by *SET DIELECTRIC*.

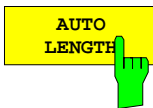


The *SET DIELECTRIC* softkey calls a submenu and the table *SET DIELECTRIC*.

The table *SET DIELECTRIC* is used to select the dielectric the relative permittivity of which determines the relation between the entry values of *MECHANICAL LENGTH* and *ELECTRICAL LENGTH*. The following applies:

$$\text{ELECTRICAL LENGTH} = (\text{PERMITTIVITY})^{1/2} \text{MECHANICAL LENGTH}$$

The same table can also be called up via the *RESPONSE FORMAT - SET DIELECTRIC* softkey (see description under softkey).



The *AUTO LENGTH* softkey sets the length offset of the selected test port such that the phase response of the S-parameter in the active display channel is minimized across the sweep range. For this purpose, the phase is approximated by a mean straight line and a conductor length is calculated from the slope of this straight line.

This softkey can be activated only with frequency sweep and when a length offset at the selected test port influences the phase of the S-parameter in the active display channel. If, for example, S_{11} is the test parameter in the active channel and PORT 2 has been selected for entry of offset parameters, *AUTO LENGTH* cannot be used since the offset length at PORT 2 has no effect on the phase of S_{11} .