

Keysight 2-Port and 4-Port PNA-X Network Analyzer

N5244B – 10 MHz to 43.5 GHz

N5245B – 900 Hz to 50.0 GHz

Data Sheet and
Technical
Specifications

Documentation Warranty

THE MATERIAL CONTAINED IN THIS DOCUMENT IS PROVIDED "AS IS," AND IS SUBJECT TO BEING CHANGED, WITHOUT NOTICE, IN FUTURE EDITIONS. FURTHER, TO THE MAXIMUM EXTENT PERMITTED BY APPLICABLE LAW, KEYSIGHT DISCLAIMS ALL WARRANTIES, EITHER EXPRESS OR IMPLIED WITH REGARD TO THIS MANUAL AND ANY INFORMATION CONTAINED HEREIN, INCLUDING BUT NOT LIMITED TO THE IMPLIED WARRANTIES OF MERCHANTABILITY AND FITNESS FOR A PARTICULAR PURPOSE. KEYSIGHT SHALL NOT BE LIABLE FOR ERRORS OR FOR INCIDENTAL OR CONSEQUENTIAL DAMAGES IN CONNECTION WITH THE FURNISHING, USE, OR PERFORMANCE OF THIS DOCUMENT OR ANY INFORMATION CONTAINED HEREIN. SHOULD KEYSIGHT AND THE USER HAVE A SEPARATE WRITTEN AGREEMENT WITH WARRANTY TERMS COVERING THE MATERIAL IN THIS DOCUMENT THAT CONFLICT WITH THESE TERMS, THE WARRANTY TERMS IN THE SEPARATE AGREEMENT WILL CONTROL.

U.S. Government Rights

U.S. Government Rights. The Software is "commercial computer software," as defined by Federal Acquisition Regulation ("FAR") 2.101. Pursuant to FAR 12.212 and 27.405-3 and Department of Defense FAR Supplement ("DFARS") 227.7202, the U.S. government acquires commercial computer software under the same terms by which the software is customarily provided to the public. Accordingly, Keysight provides the Software to U.S. government customers under its standard commercial license, which is embodied in its End User License Agreement (EULA), a copy of which can be found at <http://www.keysight.com/find/sweula>. The license set forth in the EULA represents the exclusive authority by which the U.S. government may use, modify, distribute, or disclose the Software. The EULA and the license set forth therein, does not require or permit, among other things, that Keysight: (1) Furnish technical information related to commercial computer software or commercial computer software documentation that is not customarily provided to the public; or (2) Relinquish to, or otherwise provide, the government rights in excess of these rights customarily provided to the public to use, modify, reproduce, release, perform, display, or disclose commercial computer software or commercial computer software documentation. No additional government requirements beyond those set forth in the EULA shall apply, except to the extent that those terms, rights, or licenses are explicitly required from all providers of commercial computer software pursuant to the FAR and the DFARS and are set forth specifically in writing elsewhere in the EULA. Keysight shall be under no obligation to update, revise or otherwise modify the Software. With respect to any technical data as defined by FAR 2.101, pursuant to FAR 12.211 and 27.404.2 and DFARS 227.7102, the U.S. government acquires no greater than Limited Rights as defined in FAR 27.401 or DFAR 227.7103-5 (c), as applicable in any technical data.

Contents

Corrected System Performance	9
System Dynamic Range	10
Table 1a. System Dynamic Range, Options 201 or 401, and Receiver Dynamic Range, All Options	10
Table 1b. System Dynamic Range at Test Port (dB), Options 201 or 401	11
Table 1c. System Dynamic Range at Test Port (dB), Options 21x or 41x	12
Table 1d. System Dynamic Range at Test Port (dB), Option 22x	13
Table 1e. System Dynamic Range at Test Port (dB), Options 22x or 42x (except 425)	14
Table 1f. System Dynamic Range at Test Port (dB), Option 425	15
Table 1g. System Dynamic Range at Test Port (dB), Option 425 (LFE Enabled)	16
Table 1h. System Dynamic Range at Test Port (dB), Option 425 (LFE Enabled), Combine Mode - Typical ...	16
Table 1i. System Dynamic Range at Test Port (dB), Options 22x or 42x with 029 ¹	17
Extended Dynamic Range	18
Table 2a. Extended Dynamic Range at Direct Receiver Access Input (dB) - Specification	18
Table 2b. Extended Dynamic Range at Direct Receiver Access Input (dB), Options 22x or 42x	19
Table 2c. Extended Dynamic Range at Direct Receiver Input (dB), Options 22x or 42x with 029 ¹	20
Receiver Dynamic Range	21
Table 3a. Receiver Dynamic Range (dB), All Options	21
Table 3b. Receiver Dynamic Range (dB), All Ports, Option 425 (LFE Enabled)	21
Corrected System Performance, All Options	22
Table 4a. 85056A Calibration Kit	22
Table 4b. 85056A Calibration Kit, LFE Enabled (Option 425)	24
Table 5a. N4693A Calibration Kit	25
Table 5b. N4693A Calibration Kit, LFE Enabled (Option 425)	27
Uncorrected System Performance	28
Table 6a. Directivity, All Options, All Ports (dB)	28
Table 6b. Source Match (dB)	29
Table 6c. Load Match (dB)	30
Table 6d. Reflection /Transmission Tracking, Crosstalk (dB), All Options, All Ports-Typical	30
Table 6e. Noise Mode ¹ Uncorrected System Performance (dB), Option 029 - Specification	31
Table 6f. Noise Mode ¹ Uncorrected System Performance (dB), Option 029 - Typical	32
Table 6g. LFE Enabled Uncorrected System Performance, All Ports (Option 425) - Specifications	33
Table 6h. LFE Enabled Uncorrected System Performance, All Ports (Option 425) - Typical	33

Test Port Output.....	34
Table 7. Frequency Information, All Options.....	34
Table 8a. Maximum Leveled Power (dBm), Options 201 or 401	35
Table 8b. Maximum Leveled Power (dBm), Options 21x or 41x	36
Table 8c. Maximum Leveled Power (dBm), Options 22x or 42x (except 425)	37
Table 8d. Maximum Leveled Power (dBm), Option 425	38
Table 8e. Maximum Leveled Power (dBm), Options 22x or 42x (except 425), Combine Mode - Typical.....	39
Table 8f. Maximum Leveled Power (dBm), Option 425, Combine Mode - Typical	39
Table 8g. Maximum Power (dBm), All Ports, Option 425 (LFE Enabled), Combine Mode - Typical.....	40
Table 8h. Maximum Leveled Power (dBm), Option 22x.....	40
Table 8i. Maximum Leveled Power (dBm), Options 22x or 42x with 029 ¹	41
Table 8j. Maximum Leveled Power (dBm), Options 22x or 42x with 029 ¹ , Combine Mode-Typical.....	42
Table 8k. Maximum Leveled Power (dBm), Noise Mode ¹ , Options 22x or 42x with 029 ¹ - Typical	43
Table 8l. Maximum Power (dBm), All Ports – Option 425 (LFE Enabled).....	43
Table 9a. Power Level Accuracy (dB) at Nominal Power ¹ , All Options.....	44
Table 9b. Power Level Accuracy (dB), All Ports, Option 425 (LFE Enabled)	44
Table 10a. Power Level Linearity ¹ (dB), All Options - Specification	44
Table 10b. Power Level Linearity ¹ (dB), All Options - Specification	45
Table 10c. Power Level Linearity ¹ (dB), Option 22x - Specification	45
Table 10d. Power Level Linearity ¹ (dB), All Ports, Option 425 (LFE Enabled)	45
Table 11a. Power Sweep Range (dB), Options 201 or 401.....	46
Table 11b. Power Sweep Range (dB), Options 21x or 41x	47
Table 11c. Power Sweep Range (dB), Options 22x or 42x (except 425)	48
Table 11d. Power Sweep Range (dB), Option 22x.....	49
Table 11e. Power Sweep Range (dB), Options 22x or 42x (except 425) with 029 ¹	50
Table 11f. Power Sweep Range (dB), Option 425.....	51
Table 11g. Power Sweep Range (dB) –Option 425 (LFE Enabled).....	51
Table 12. Nominal Power (Preset Power, dBm).....	52
Table 13. Power Resolution and Maximum/Minimum Settable Power, All Ports ¹	52
Table 14a. 2 nd and 3 rd Harmonics at Max Specified Power (dBc), All Options - Typical.....	52
Table 14b. 2 nd and 3 rd Harmonics at Max Specified Power (dBc), All Ports, Option 425 (LFE Enabled) - Typical.....	53
Table 15. Non-Harmonic Spurs at Nominal Power (dBc), All Options - Typical.....	53
Table 16a. Phase Noise (dBc/Hz), All Options, All Ports - Typical.....	54
Table 16b. Phase Noise (dBc/Hz), All Ports, Option 425 (LFE Enabled) - Typical.....	54
Test Port Input	55
Table 17a. Noise Floor ¹ (dBm) @ 10 Hz IFBW, All Options, All Ports	55

Table 17b. LFE Enabled Noise Floor (dBm) @ 10 Hz IFBW (Option 425)	55
Table 18a. 0.1 dB Compression, All Options, All Ports - Typical.....	56
Table 18b. LFE Enabled 0.1 dB Compression, All Ports (Option 425) - Typical.....	56
Table 18c. LFE Enabled Compression, All Ports (Option 425) - Specification	56
Table 19. Compression, All Ports - Specification	57
Table 20a. Trace Noise ¹ Magnitude (dB rms), All Options, All Ports.....	57
Table 20b. Trace Noise ¹ Magnitude (dB rms), All Ports, Option 425 (LFE Enabled).....	58
Table 20c. Trace Noise ¹ Phase (deg rms), All Options, All Ports.....	58
Table 20d. Trace Noise ¹ Phase (deg rms), All Ports, Option 425 (LFE Enabled).....	58
Table 21. Reference Level - Specification.....	59
Table 22a. Stability ¹ - Typical.....	59
Table 22b. Stability ¹ , Option 425 (LFE Enabled) - Typical.....	59
Table 23 Damage Input Level - Specification.....	60
Noise Receiver Input (Option 029 only).....	61
Table 24. Noise Receiver Bandwidth	61
Table 25. Receiver Noise Figure (dB), Port 2, at 4 MHz BW, High Gain Setting	61
Table 26. Noise Figure Trace Noise ¹ (dB rms) at 4 MHz BW, All Gain Settings	61
Table 27. Noise Receiver Linearity (dB) at 4 MHz BW - Specification	61
Table 28. Noise Receiver Input Range - Specification	62
Dynamic Accuracy	63
Table 29. Dynamic Accuracy - Specification	63
Table 30. Test Port Input (Group Delay) ¹	68
General Information	69
Table 31. Miscellaneous Information	69
Table 32. Front Panel Information, All Options.....	69
Table 32. (Continued) Front Panel Information, All Options.....	70
Table 33. Rear Panel Information, All Options.....	70
Table 33. (Continued) Rear Panel Information, All Options.....	71
Table 33. (Continued) Rear Panel Information, All Options.....	72
Table 33. (Continued) Rear Panel Information, All Options.....	73
Table 34. Analyzer Dimensions and Weight	74
Regulatory and Environmental Information	74
Measurement Throughput Summary	75
Table 35a. Cycle Time (ms) for Measurement Completion, All Models, All Options - Typical.....	75
Table 35b. N5244B Cycle Time (ms) for Full-Span Measurement Completion - Typical.....	76

Table 35c. N5245B Cycle Time (ms) for Full-Span Measurement Completion - Typical	76
Table 36. Cycle Time vs. IF Bandwidth - Typical	77
Table 37. Cycle Time (ms) vs. Number of Points - Typical	78
Table 38. Data Transfer Time ¹ (ms) - Typical.....	79
Front-Panel Jumpers.....	80
Table 39. Measurement Receiver Inputs (dBm) - Typical.....	80
Table 40a. Reference Receiver Inputs and Reference Source Outputs (dBm) - Typical	81
Table 40b. Reference Receiver Inputs and Reference Source Outputs (dBm) - Typical	82
Table 40c. Reference Receiver Inputs and Reference Source Outputs (dBm) - Typical	83
Table 41a. Source Outputs (dBm) - Typical.....	84
Table 41b. Source Outputs (dBm) - Typical.....	85
Table 42. Coupler Inputs (dB) - Typical	86
Table 43. Damage Level - Typical.....	86
Test Set Block Diagrams.....	87
Figure 1. 2-Port N5244B and N5245B Base Unit Option 201	87
Figure 2. 2-Port N5244B and N5245B Option 217.....	88
Figure 3. 2-Port N5244B and N5245B Option 219.....	88
Figure 4. 2-Port N5244B and N5245B Option 222.....	89
Figure 5. 2-Port N5244B and N5245B Option 224.....	89
Figure 6. 2-Port N5244B and N5245B Option 224 with 029	90
Figure 7. 4-Port N5244B and N5245B Base Unit Option 401	90
Figure 8. 4-Port N5244B and N5245B Option 417.....	91
Figure 9. 4-Port N5244B and N5245B Option 419.....	91
Figure 10. 4-Port N5244B and N5245B Option 422	92
Figure 11. 4-Port N5244B and N5245B Option 423	92
Figure 12. 4-Port N5244B and N5245B Option 423 with 029	93
Figure 13. Option 425 Low Frequency Extension	93
Figure 14. Receiver Block Diagram.....	94

This is a complete list of the technical specifications for the N5244B and N5245B with the following options:

Option 029, adds hardware and firmware for high-accuracy noise figure measurements. It requires one of Option 22x or 42x. [See the block diagram.](#)

Option 201, 2-port standard test set (includes six front-panel access loops) and power range. Figure 1. 2-Port N5244B and N5245B Base Unit Option 201

Option 217, 2-port standard test set (includes six front-panel access loops), power range, and source and receiver attenuators (extended power range). [below.](#)

Option 219, 2-port standard test set (includes six front-panel access loops), power range, source and receiver attenuators (extended power range), and bias-tees. [See the block diagram.](#)

Option 222, 2-port standard test set (includes six front-panel access loops), power range, source and receiver attenuators (extended power range), internal second source, a combiner, and mechanical switches to the 2-port analyzer. [below.](#)

Option 224, 2-port standard test set (includes six front-panel access loops), power range, source and receiver attenuators (extended power range), internal second source, a combiner, mechanical switches to the 2-port analyzer, and bias tees. [See the block diagram.](#)

Option 401, 4-port standard test set (includes twelve front-panel access loops), power range, and an internal second source (Option 080 recommended). [below.](#)

Option 417, 4-port standard test set (includes twelve front-panel access loops), power range, internal second source (Option 080 recommended), and source and receiver attenuators (extended power range). [below.](#)

Option 419, 4-port standard test set (includes twelve front-panel access loops), power range, internal second source (Option 080 recommended), and source and receiver attenuators (extended power range), and bias-tees. [See the block diagram.](#)

Option 422, 4-port standard test set (includes six front-panel access loops), power range, source and receiver attenuators (extended power range), internal second source, a combiner, and mechanical switches to the 4-port analyzer. [below.](#)

Option 423, 4-port standard test set (includes six front-panel access loops), power range, source and receiver attenuators (extended power range), internal second source, a combiner, mechanical switches to the 4-port analyzer, and bias tees. [See the block diagram.](#)

Option 425, (N5245B only) 4-port configurable test set, source and receiver attenuators, internal second source, combiner, mechanical switches, low frequency extension (LFE), and dedicated 50 GHz noise receiver. [See the block diagram.](#)

Notes

Specifications for the N5244BS and N5245BS Option H85, when configured in standard configuration, are the same as those of closest N5244B and N5245B option configuration.

[The Corrected System Performance with Cal Kits](#) and [Dynamic Accuracy Charts](#) apply ONLY to N5244B/45B models with serial numbers starting with MY5244/45, SG5244/45, and US5244/45, and above. This document provides technical specifications for the 85056A calibration kit, and the N4693A 2-Port ECal module. Please download our free Uncertainty Calculator from http://www.keysight.com/find/na_calculator to generate the curves for your calibration kit and PNA setup.

For all tables in this data sheet, the specified performance at the exact frequency of a break is the degraded value of the two specifications at that frequency.

Definitions

All specifications and characteristics apply over a $25\text{ }^{\circ}\text{C} \pm 5\text{ }^{\circ}\text{C}$ range (unless otherwise stated) and 90 minutes after the instrument has been turned on.

Specification (spec.): Warranted performance. Specifications include guardbands to account for the expected statistical performance distribution, measurement uncertainties, and changes in performance due to environmental conditions.

Characteristic (char.): A performance parameter that the product is expected to meet before it leaves the factory, but that is not verified in the field and is not covered by the product warranty. A characteristic includes the same guardbands as a specification.

Typical (typ.): Expected performance of an average unit which does not include guardbands. It is not covered by the product warranty.

Nominal (nom.): A general, descriptive term that does not imply a level of performance. It is not covered by the product warranty.

Calibration: The process of measuring known standards to characterize a network analyzer's systematic (repeatable) errors.

Corrected (residual): Indicates performance after error correction (calibration). It is determined by the quality of calibration standards and how well "known" they are, plus system repeatability, stability, and noise.

Uncorrected (raw): Indicates instrument performance without error correction. The uncorrected performance affects the stability of a calibration.

Standard: When referring to the analyzer, this includes no options unless noted otherwise.

Standard and LFE measurements: With option 425, which adds low frequency extension (LFE) hardware, the LFE measurement range overlaps with the standard measurement range from 10 MHz to 100 MHz. With LFE Enabled, measurements from 500 Hz to 100 MHz use LFE hardware. With LFE Disabled, measurements from 10 MHz to 100 MHz use standard hardware. To measure below 10 MHz, LFE must be enabled. All measurements above 100 MHz use standard hardware, regardless of the LFE Enabled/Disabled setting.

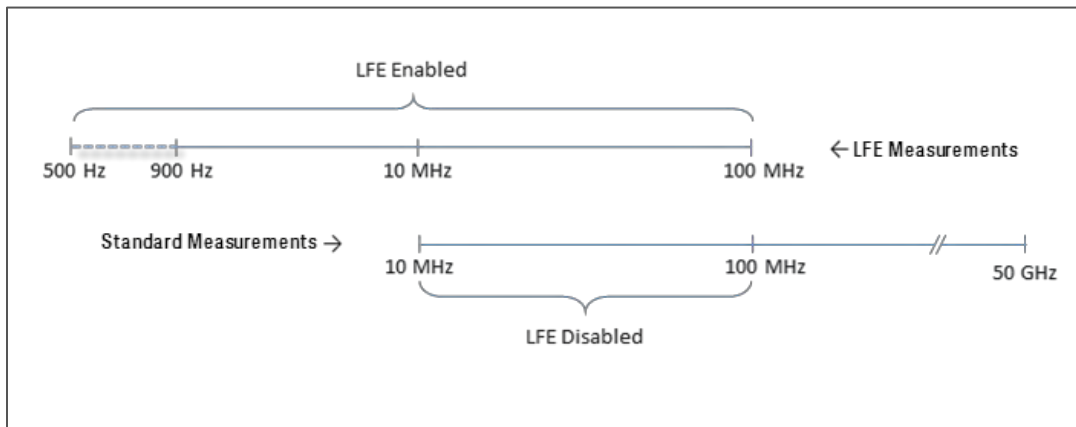

Corrected System Performance

The specifications in this section apply for measurements made with the N5244B and N5245B analyzer with the following conditions:

- 10 Hz IF bandwidth
 - No averaging applied to data
 - Isolation calibration with an averaging factor of 8
 - Source in filtered mode where applicable
-
- **System Dynamic Range** is defined as the specified source maximum output power (A) minus the specified noise floor (B).
 - **Extended Dynamic Range at Direct Access Input** is defined as the specified source maximum output power (A) minus the specified direct receiver access input noise floor (not shown).
 - **Receiver Dynamic Range** is defined as the typical test port 0.1 dB compression (C) minus the typical noise floor (D).

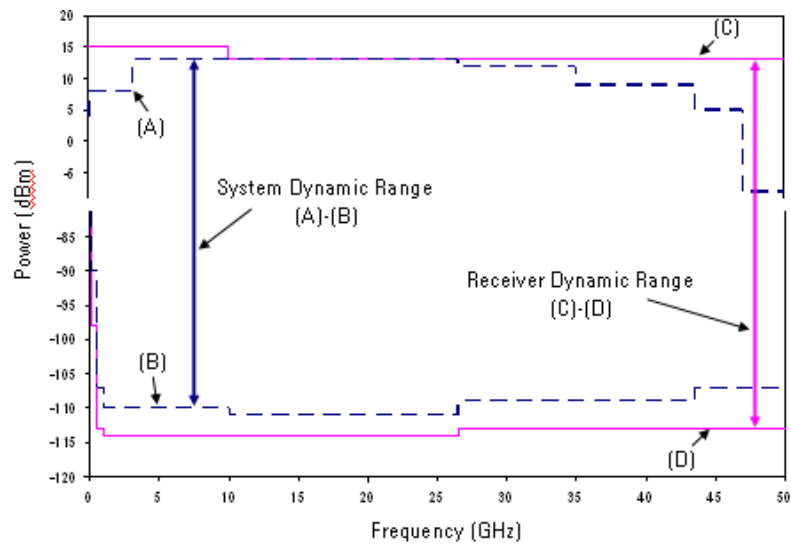

System Dynamic Range

Table 1a. System Dynamic Range, Options 201 or 401, and Receiver Dynamic Range, All Options

Description	Specification, Options 201, 401			Typical, All Options		
	System Dynamic Range (dB) (A)-(B)	Max Leveled Output Power (dBm) (A)	Test Port Noise Floor (dBm) (B)	Receiver Dynamic Range (dB) (C)-(D)	Test Port Compression at 0.1 dB (dBm) (C)	Test Port Noise Floor (dBm) (D)
	Ports 1, 3 ¹	Ports 1, 3 ¹	All	All	All	All
10 MHz to 50 MHz	74	4	-70	91	15	-76
50 MHz to 100 MHz	93	8	-85	106	15	-91
100 MHz to 500 MHz	98	8	-90	113	15	-98
500 MHz to 1 GHz	114	8	-106	127	15	-112
1 GHz to 2 GHz	118	8	-110	129	15	-114
2 GHz to 3.2 GHz	118	8	-110	129	15	-114
3.2 GHz to 10 GHz	123	13	-110	129	15	-114
10 GHz to 16 GHz	124	13	-111	127	13	-114
16 GHz to 20 GHz	124	13	-111	127	13	-114
20 GHz to 26.5 GHz	124	13	-111	127	13	-114
26.5 GHz to 30 GHz	120	12	-108	126	13	-113
30 GHz to 32 GHz	119	11	-108	126	13	-113
32 GHz to 35 GHz	120	12	-108	126	13	-113
35 GHz to 40 GHz	117	9	-108	126	13	-113
40 GHz to 43.5 GHz	118	9	-109	126	13	-113
43.5 GHz to 47 GHz	112	5	-107	126	13	-113
47 GHz to 50 GHz	102	-5	-107	126	13	-113

¹ Either port can be used as the source port. Any other port can be used as the receiver port.

Table 1b. System Dynamic Range at Test Port (dB), Options 201 or 401

Description	Specification		Typical	
	Ports 1, 3 ¹	Ports 2, 4 ¹	Ports 1, 3 ¹	Ports 2, 4 ¹
10 MHz to 50 MHz	74	82	88	95
50 MHz to 100 MHz	93	98	104	111
100 MHz to 500 MHz	98	103	111	118
500 MHz to 1 GHz	114	119	126	131
1 GHz to 2 GHz	118	123	128	133
2 GHz to 3.2 GHz	118	123	128	133
3.2 GHz to 10 GHz	123	123	133	133
10 GHz to 16 GHz	124	124	132	131
16 GHz to 20 GHz	124	124	131	131
20 GHz to 26.5 GHz	124	124	131	131
26.5 GHz to 30 GHz	120	120	130	130
30 GHz to 32 GHz	119	119	129	129
32 GHz to 35 GHz	120	120	130	130
35 GHz to 40 GHz	117	117	126	126
40 GHz to 43.5 GHz	118	118	126	126
43.5 GHz to 47 GHz	112	112	124	124
47 GHz to 50 GHz	102	102	115	115

¹ Either port can be used as the source port. Any other port can be used as the receiver port.

Table 1c. System Dynamic Range at Test Port (dB), Options 21x or 41x

Description	Specification		Typical (dB)	
	Ports 1, 3 ¹	Ports 2, 4 ¹	Ports 1, 3 ¹	Ports 2, 4 ¹
10 MHz to 50 MHz	74	82	89	95
50 MHz to 100 MHz	93	98	104	111
100 MHz to 500 MHz	98	103	111	118
500 MHz to 1 GHz	114	119	126	132
1 GHz to 2 GHz	118	123	126	133
2 GHz to 3.2 GHz	118	123	129	131
3.2 GHz to 10 GHz	123	123	132	132
10 GHz to 16 GHz	122	122	130	130
16 GHz to 20 GHz	121	121	129	129
20 GHz to 26.5 GHz	121	121	129	129
26.5 GHz to 30 GHz	117	117	128	128
30 GHz to 32 GHz	115	115	126	126
32 GHz to 35 GHz	117	117	127	127
35 GHz to 40 GHz	112	112	122	122
40 GHz to 43.5 GHz	113	113	122	122
43.5 GHz to 47 GHz	106	106	119	119
47 GHz to 50 GHz	96	96	108	108

¹ Either port can be used as the source port. Any other port can be used as the receiver port.

Table 1d. System Dynamic Range at Test Port (dB), Option 22x

Description	Specification		Typical (dB)	
	Source 2 Out 1	Source 2 Out 2	Source 2 Out 1	Source 2 Out 2
10 MHz to 50 MHz	74	83	89	95
50 MHz to 100 MHz	93	100	104	111
100 MHz to 500 MHz	98	105	111	118
500 MHz to 1 GHz	114	119	126	132
1 GHz to 2 GHz	118	123	127	134
2 GHz to 3.2 GHz	118	123	127	132
3.2 GHz to 10 GHz	124	126	134	134
10 GHz to 16 GHz	123	124	133	132
16 GHz to 20 GHz	125	125	133	133
20 GHz to 26.5 GHz	125	125	133	133
26.5 GHz to 30 GHz	122	122	132	132
30 GHz to 32 GHz	121	122	131	132
32 GHz to 35 GHz	122	122	132	132
35 GHz to 40 GHz	119	120	128	129
40 GHz to 43.5 GHz	120	121	128	129
43.5 GHz to 47 GHz	114	115	126	127
47 GHz to 50 GHz	105	105	118	121

Table 1e. System Dynamic Range at Test Port (dB), Options 22x or 42x (except 425)

Description	Specification		Typical			
	Ports 1, 3 ¹	Ports 2, 4 ¹	Ports 1, 3 ¹	Ports 2, 4 ¹	Source 1 Port 1 Combine Mode	Source 2 Port 1 Combine Mode
10 MHz to 50 MHz	74	80	89	95	82	83
50 MHz to 100 MHz	93	98	104	111	97	97
100 MHz to 500 MHz	98	103	111	118	104	104
500 MHz to 1 GHz	114	119	125	131	118	118
1 GHz to 2 GHz	118	123	126	132	120	120
2 GHz to 3.2 GHz	118	123	126	131	120	121
3.2 GHz to 10 GHz	123	123	132	132	124	123
10 GHz to 16 GHz	122	122	130	129	121	121
16 GHz to 20 GHz	121	121	128	128	117	117
20 GHz to 26.5 GHz	121	121	128	128	117	117
26.5 GHz to 30 GHz	117	117	127	127	114	113
30 GHz to 32 GHz	115	115	126	126	114	113
32 GHz to 35 GHz	117	117	126	126	114	113
35 GHz to 40 GHz	112	112	122	121	110	108
40 GHz to 43.5 GHz	113	113	122	121	110	108
43.5 GHz to 47 GHz	105	105	119	119	107	103
47 GHz to 50 GHz	95	95	109	110	96	92

¹ Either port can be used as the source port. Any other port can be used as the receiver port.

Table 1f. System Dynamic Range at Test Port (dB), Option 425

Description	Specification		Typical			
	Ports 1, 3 ¹	Ports 2, 4 ¹	Ports 1, 3 ¹	Ports 2, 4 ¹	Source 1 Port 1 Combine Mode	Source 2 Port 1 Combine Mode
10 MHz to 50 MHz ¹	67	73	82	88	75	75
50 MHz to 100 MHz ¹	88	93	98	105	92	92
100 MHz to 500 MHz	93	98	105	112	99	99
500 MHz to 1 GHz	109	114	119	125	113	113
1 GHz to 2 GHz	116	121	123	129	118	118
2 GHz to 3.2 GHz	116	121	123	126	118	119
3.2 GHz to 10 GHz	121	121	129	129	122	121
10 GHz to 16 GHz	120	120	127	127	119	119
16 GHz to 20 GHz	119	119	127	127	116	116
20 GHz to 26.5 GHz	119	119	127	127	116	116
26.5 GHz to 30 GHz	115	115	126	126	112	111
30 GHz to 32 GHz	114	114	125	125	112	111
32 GHz to 35 GHz	116	116	126	126	112	111
35 GHz to 40 GHz	112	112	123	123	111	111
40 GHz to 43.5 GHz	113	113	123	123	111	111
43.5 GHz to 47 GHz	105	105	119	119	106	106
47 GHz to 50 GHz	95	95	109	109	95	95

¹ With Option 425 installed and LFE disabled, applied to frequencies \leq 100 MHz. Above 100 MHz, performance is the same for both LFE enabled or disabled. For LFE enabled performance \leq 100 MHz, see Table 1g.

Table 1g System Dynamic Range at Test Port (dB), Option 425 (LFE Enabled)

Description	Specification	Typical	Effective Dynamic Range ¹ (Typical)
500 Hz to 900 Hz	--	105	103
900 Hz to 1 kHz	93	109	105
1 kHz to 100 kHz	103	109	99
100 kHz to 1 MHz	119	124	124
1 MHz to 5 MHz	118	125	119
5 MHz to 10 MHz	111	117	117
10 MHz to 50 MHz	110	116	116
50 MHz to 100 MHz	110	116	116

¹ Effective dynamic range is when the crosstalk is greater than the noise floor, and thus crosstalk limits the dynamic range. Crosstalk only limits the dynamic range for IF bandwidths < 1 kHz.

Table 1h. System Dynamic Range at Test Port (dB), Option 425 (LFE Enabled), Combine Mode - Typical

Description	Source 1 Port 1	Source 2 Port 1
500 Hz to 900 Hz	99	98
900 Hz to 1 kHz	103	102
1 kHz to 100 kHz	104	103
100 kHz to 1 MHz	118	118
1 MHz to 5 MHz	119	119
5 MHz to 10 MHz	111	110
10 MHz to 50 MHz	111	110
50 MHz to 100 MHz	111	110

Table 1i. System Dynamic Range at Test Port (dB), Options 22x or 42x with 029¹

Description	Specification		Typical			
	Port 1	Port 2	Port 1	Port 2	Source 1 Port 1 Combine Mode	Source 2 Port 1 Combine Mode
10 MHz to 50 MHz	74	80	87	95	80	81
50 MHz to 100 MHz	93	98	102	110	95	95
100 MHz to 500 MHz	98	103	109	117	102	102
500 MHz to 1 GHz	114	119	122	128	116	116
1 GHz to 2 GHz	118	123	124	130	118	118
2 GHz to 3.2 GHz	118	123	124	130	118	118
3.2 GHz to 10 GHz	123	123	130	130	122	121
10 GHz to 16 GHz	121	121	127	127	118	118
16 GHz to 20 GHz	119	119	127	127	116	116
20 GHz to 26.5 GHz	119	119	127	127	116	116
26.5 GHz to 30 GHz	115	115	126	126	114	113
30 GHz to 32 GHz	113	113	124	124	114	113
32 GHz to 35 GHz	115	115	126	126	114	113
35 GHz to 40 GHz	109	109	121	121	109	108
40 GHz to 43.5 GHz	110	110	121	121	109	108
43.5 GHz to 47 GHz	103	103	117	118	105	103
47 GHz to 50 GHz	92	92	106	107	93	89

¹ Option 029 affects system dynamic range with port 1 or port 2 as the source port. Refer to Table 2c and 2d for the system dynamic range with port 3 or port 4 as the source port. Port 1 impedance tuner switch is in bypass position and port 2 noise receiver switch is in normal position.

Extended Dynamic Range

Table 2a. Extended Dynamic Range at Direct Receiver Access Input (dB) – Specification

Description	Options 201, 401		Options 21x, 41x	
	Ports 1, 3 ¹	Ports 2, 4 ¹	Ports 1, 3 ¹	Ports 2, 4 ¹
10 MHz to 50 MHz	109	117	109	117
50 MHz to 100 MHz	113	118	113	118
100 MHz to 500 MHz	118	123	118	123
500 MHz to 1 GHz	135	140	135	140
1 GHz to 2 GHz	138	143	138	143
2 GHz to 3.2 GHz	130	135	130	135
3.2 GHz to 10 GHz	135	135	135	135
10 GHz to 16 GHz	136	136	134	134
16 GHz to 20 GHz	136	136	133	133
20 GHz to 26.5 GHz	136	136	133	133
26.5 GHz to 30 GHz	130	130	127	127
30 GHz to 32 GHz	129	129	125	125
32 GHz to 35 GHz	130	130	127	127
35 GHz to 40 GHz	127	127	122	122
40 GHz to 43.5 GHz	128	128	123	123
43.5 GHz to 47 GHz	122	122	116	116
47 GHz to 50 GHz	112	112	106	106

¹Either port can be used as the source port. Any other port can be used as the receiver port.

Table 2b. Extended Dynamic Range at Direct Receiver Access Input (dB), Options 22x or 42x

Description	Specification				Typical	
	Option 22x		Options 22x, 42x		Options 22x, 42x	
	Source 2 Out 1	Source 2 Out 2	Ports 1, 3 ¹	Ports 2, 4 ¹	Source 1 Port 1 Combine Mode	Source 2 Port 1 Combine Mode
10 MHz to 50 MHz	109	118	109	115	117	118
50 MHz to 100 MHz	113	120	113	118	117	117
100 MHz to 500 MHz	118	125	118	123	124	124
500 MHz to 1 GHz	135	140	135	140	139	139
1 GHz to 2 GHz	138	143	138	143	140	140
2 GHz to 3.2 GHz	130	135	130	135	132	133
3.2 GHz to 10 GHz	136	138	135	135	136	135
10 GHz to 16 GHz	135	136	134	134	133	133
16 GHz to 20 GHz	137	137	133	133	129	129
20 GHz to 26.5 GHz	137	137	133	133	129	129
26.5 GHz to 30 GHz	132	132	127	127	124	123
30 GHz to 32 GHz	131	132	125	125	124	123
32 GHz to 35 GHz	132	132	127	127	124	123
35 GHz to 40 GHz	129	130	122	122	120	118
40 GHz to 43.5 GHz	130	131	123	123	120	118
43.5 GHz to 47 GHz	124	125	115	115	117	113
47 GHz to 50 GHz	115	115	105	105	106	102

¹Either port can be used as the source port. Any other port can be used as the receiver port.

Table 2c. Extended Dynamic Range at Direct Receiver Input (dB), Options 22x or 42x with 029¹

Description	Specification		Typical	
	Port 1	Port 2	Source 1 Port 1 Combine Mode	Source 2 Port 1 Combine Mode
10 MHz to 50 MHz	109	115	115	116
50 MHz to 100 MHz	113	118	115	115
100 MHz to 500 MHz	118	123	122	122
500 MHz to 1 GHz	135	140	137	137
1 GHz to 2 GHz	138	143	138	138
2 GHz to 3.2 GHz	130	135	130	130
3.2 GHz to 10 GHz	135	135	134	133
10 GHz to 16 GHz	133	133	130	130
16 GHz to 20 GHz	131	131	128	128
20 GHz to 26.5 GHz	131	131	128	128
26.5 GHz to 30 GHz	125	125	124	123
30 GHz to 32 GHz	123	123	124	123
32 GHz to 35 GHz	125	125	124	123
35 GHz to 40 GHz	119	119	119	118
40 GHz to 43.5 GHz	120	120	119	118
43.5 GHz to 47 GHz	113	113	115	113
47 GHz to 50 GHz	102	102	103	99

¹ Option 029 affects system dynamic range with port 1 or port 2 as the source port. Refer to Table 3b for the extended dynamic range with port 3 or port 4 as the source port. Port 1 impedance tuner switch is in bypass position and port 2 noise receiver switch is in normal position.

Receiver Dynamic Range

Table 3a. Receiver Dynamic Range (dB), All Options

Description	Typical
10 MHz to 50 MHz ¹	91
50 MHz to 100 MHz ¹	106
100 MHz to 500 MHz	113
500 MHz to 1 GHz	127
1 GHz to 2 GHz	129
2 GHz to 3.2 GHz	129
3.2 GHz to 10 GHz	129
10 GHz to 16 GHz	127
16 GHz to 20 GHz	127
20 GHz to 26.5 GHz	127
26.5 GHz to 30 GHz	126
30 GHz to 32 GHz	126
32 GHz to 35 GHz	126
35 GHz to 40 GHz	126
40 GHz to 43.5 GHz	126
43.5 GHz to 47 GHz	126
47 GHz to 50 GHz	126

¹ With Option 425 installed and LFE disabled, applied to frequencies \leq 100 MHz. Above 100 MHz, performance is the same for both LFE enabled or disabled.

Table 3b. Receiver Dynamic Range (dB), All Ports, Option 425 (LFE Enabled)

Description	Typical
500 Hz to 900 Hz	106
900 Hz to 1 kHz	109
1 kHz to 100 kHz	109
100 kHz to 1 MHz	123
1 MHz to 5 MHz	123
5 MHz to 10 MHz	119
10 MHz to 50 MHz	120
50 MHz to 100 MHz	120

Corrected System Performance, All Options

Specifications are valid for temperatures of $23^{\circ}\pm 3^{\circ}\text{C}$ and $< 1^{\circ}\text{C}$ deviation from the calibration temperature. Specifications assume an N4697F flexible test port cable and a full 2-port calibration. For instruments with Option 029, the port 1 noise tuner switch is set to the bypass position, and the port 2 noise receiver switch is set to the normal position.

Note: For any S_{ii} reflection measurement:

- $S_{jj} = 0$.

For any S_{ij} transmission measurement:

- $S_{ji} = S_{ij}$ when $S_{ij} \leq 1$
- $S_{ji} = 1/S_{ij}$ when $S_{ij} > 1$
- $S_{kk} = 0$ for all k

Please download our free Uncertainty Calculator from http://www.keysight.com/find/na_calculator for specifications for other calibration kits and measurement setups.

Table 4a. 85056A Calibration Kit

Description	Specification (dB)						
	10 MHz to 50 MHz	50 MHz to 2 GHz	2 GHz to 10 GHz	10 GHz to 20 GHz	20 GHz to 30 GHz	30 GHz to 40 GHz	40 GHz to 50 GHz
Directivity	41	41	41	41	37	37	35
Source Match	41	41	37	37	33	33	31
Load Match	41	41	41	41	37	37	35
Reflection Tracking							
Mag	± 0.0015	± 0.0015	± 0.0082	± 0.0082	± 0.021	± 0.021	± 0.028
Phase ($^{\circ}$)	± 0.0093	± 0.0093	± 0.055	± 0.055	± 0.14	± 0.14	± 0.19
Transmission Tracking							
Mag	± 0.061	± 0.069	± 0.089	± 0.079	± 0.15	± 0.15	± 0.20
Phase ($^{\circ}$)	± 0.41	± 0.46	± 0.59	± 0.52	± 1.0	± 1.0	± 1.4

Transmission Uncertainty

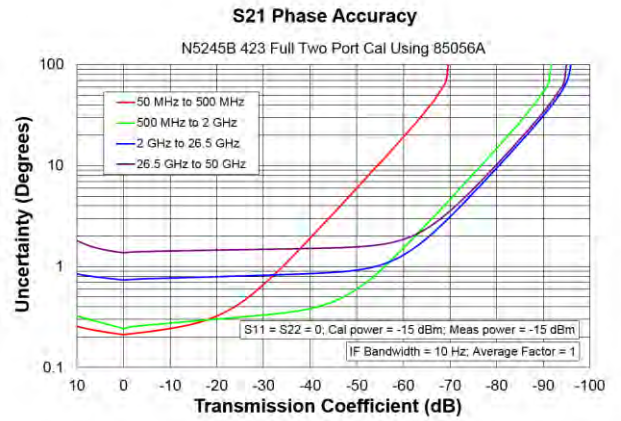
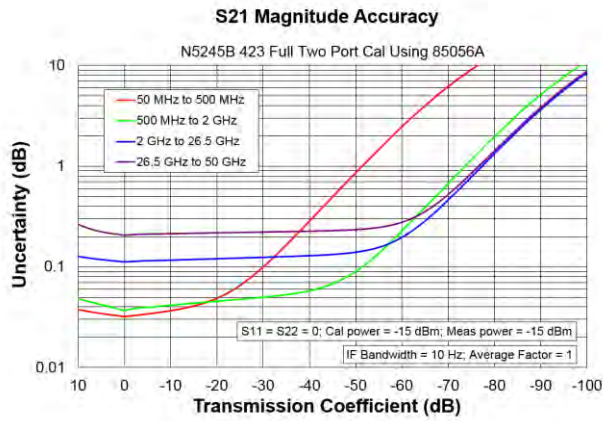

Reflection Uncertainty

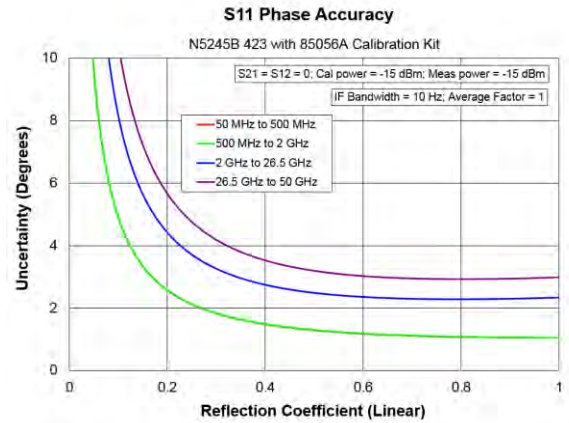
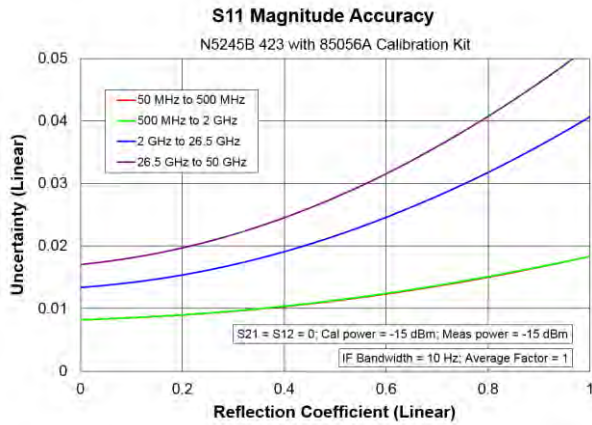
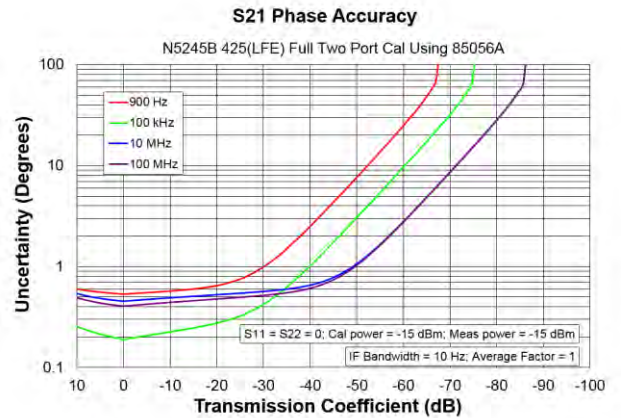
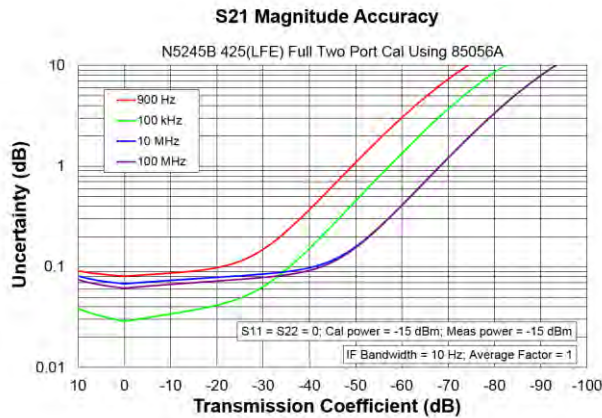

Table 4b. 85056A Calibration Kit, LFE Enabled (Option 425)

Description	Specification (dB)				
	1 kHz to 10 kHz	10 kHz to 1 MHz	1 MHz to 5 MHz	5 MHz to 50 MHz	50 MHz to 100 MHz
Directivity	41	41	41	41	41
Source Match	41	41	41	41	41
Load Match	41	41	41	41	41
Reflection Tracking					
Mag	±0.0015	±0.0015	±0.0015	±0.0015	±0.0015
Phase (°)	±0.0093	±0.0093	±0.0093	±0.0093	±0.0093
Transmission Tracking					
Mag	±0.065	±0.021	±0.046	±0.061	±0.055
Phase (°)	±0.43	±0.14	±0.31	±0.41	±0.36

Transmission Uncertainty, Option 425



Reflection Uncertainty, Option 425

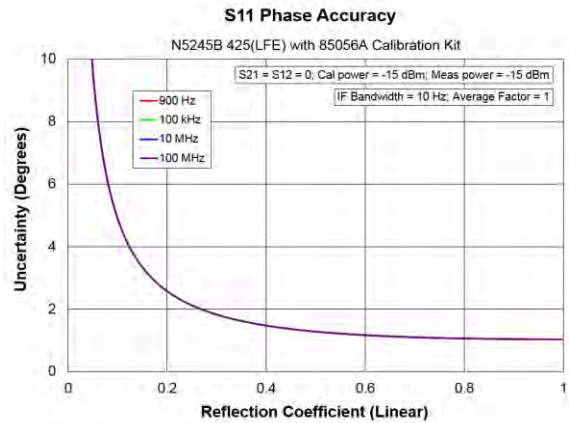
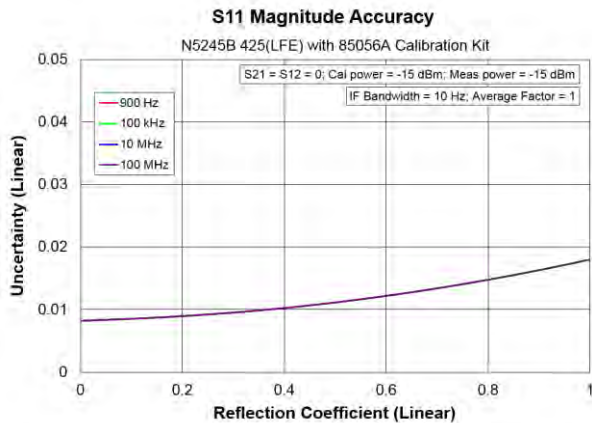
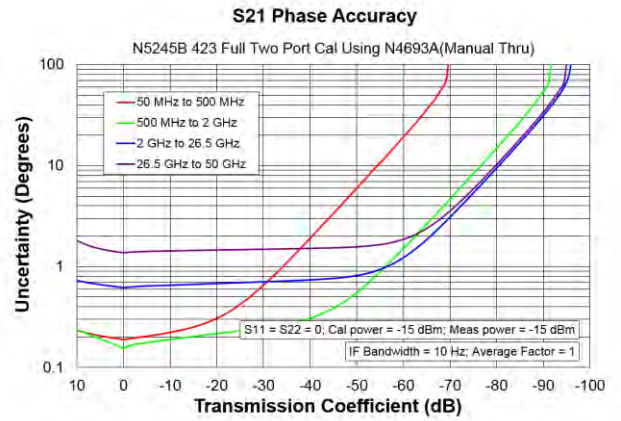
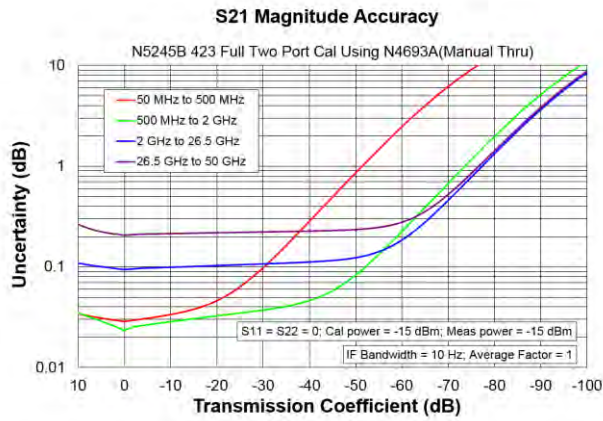

Table 5a. N4693A Calibration Kit

Description	Specification (dB)						
	10 MHz to 50 MHz	50 MHz to 2 GHz	2 GHz to 10 GHz	10 GHz to 20 GHz	20 GHz to 30 GHz	30 GHz to 40 GHz	40 GHz to 50 GHz
Directivity	32	42	49	45	41	41	36
Source Match	25	44	42	37	35	35	32
Load Match	31	40	44	41	38	38	33
Reflection Tracking							
Mag	±0.051	±0.031	±0.041	±0.051	±0.061	±0.061	±0.081
Phase (°)	±0.34	±0.20	±0.27	±0.34	±0.40	±0.40	±0.54
Transmission Tracking							
Mag	±0.30	±0.066	±0.058	±0.083	±0.13	±0.13	±0.20
Phase (°)	±2.0	±0.44	±0.38	±0.55	±0.83	±0.83	±1.4

Transmission Uncertainty



Reflection Uncertainty

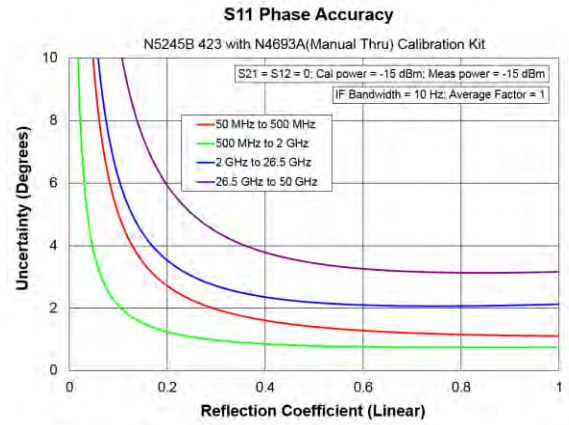
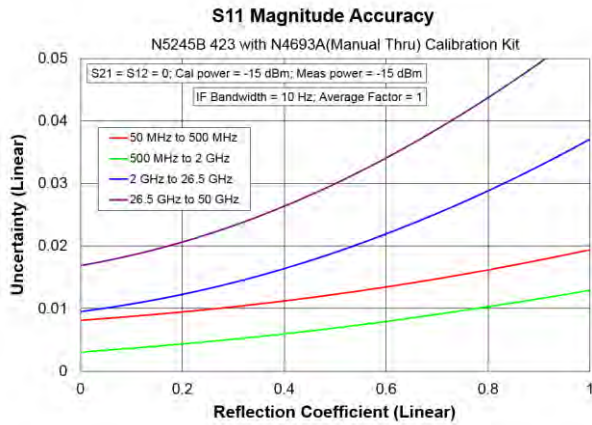
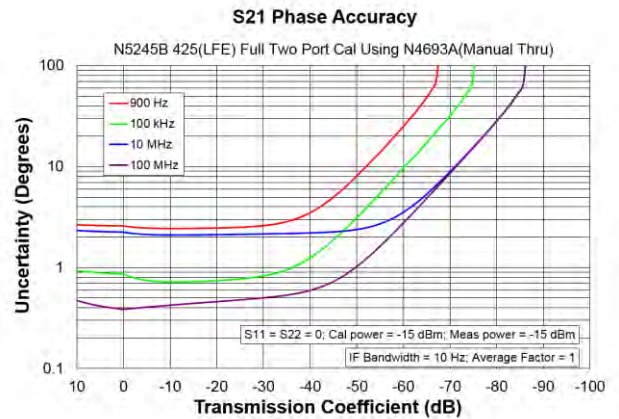
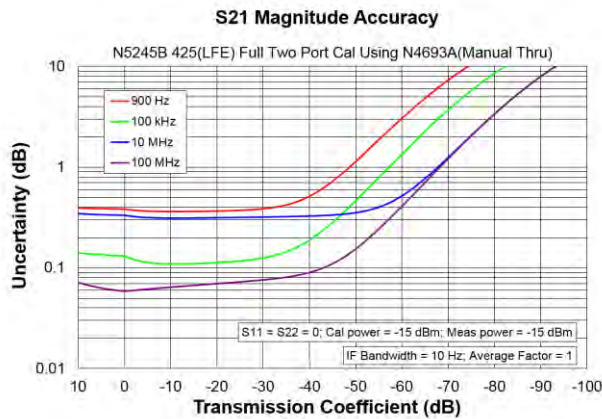

Table 5b. N4693A Calibration Kit, LFE Enabled (Option 425)

Description	Specification (dB)				
	1 kHz to 10 kHz	10 kHz to 1 MHz	1 MHz to 5 MHz	5 MHz to 50 MHz	50 MHz to 100 MHz
Directivity	32	32	32	32	42
Source Match	25	25	25	25	44
Load Match	31	32	32	31	40
Reflection Tracking					
Mag	±0.051	±0.051	±0.051	±0.051	±0.031
Phase (°)	±0.34	±0.34	±0.34	±0.34	±0.20
Transmission Tracking					
Mag	±0.32	±0.094	±0.22	±0.30	±0.052
Phase (°)	±2.2	±0.62	±1.5	±2.0	±0.34

Transmission Uncertainty, Option 425



Reflection Uncertainty, Option 425

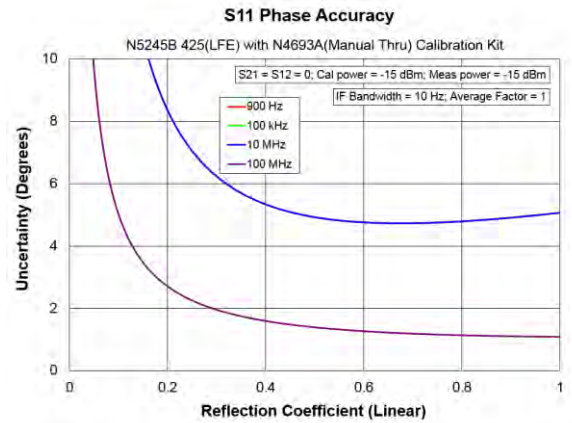
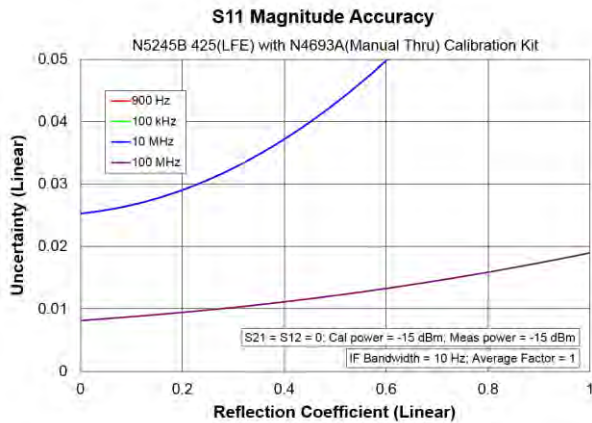

Uncorrected System Performance

Specifications apply to following conditions:

- Over environmental temperature of 25 °C ±5 °C, with less than 1°C variation from the calibration temperature.
- Cable loss not included in Transmission Tracking.
- Crosstalk measurement conditions: normalized to a thru, measured with shorts on all ports, 10 Hz IF bandwidth, averaging factor of 8, alternate mode, source power set to the specified maximum power.
- With option 029, port 1 impedance tuner switch is in bypass position and port 2 noise receiver switch is in normal position unless specified. Refer to Options 201, 21x, 22x, 401, 41x, 42x for Option 029 Ports 3 and 4 performances.

Table 6a. Directivity, All Options, All Ports (dB)

Description	Specification	Typical
10 MHz to 50 MHz ¹	18	21
50 MHz to 200 MHz ¹	22	27
200 MHz to 500 MHz	23	27
500 MHz to 3.2 GHz	23	30
3.2 GHz to 10 GHz	22	25
10 GHz to 13.5 GHz	18	23
13.5 GHz to 16 GHz	18	21
16 GHz to 20 GHz	18	20
20 GHz to 24 GHz	16	20
24 GHz to 35 GHz	16	22
35 GHz to 43.5 GHz	15	21
43.5 GHz to 47 GHz	15	21
47 GHz to 50 GHz	15	19

¹ With Option 425 installed and LFE disabled, applied to frequencies ≤ 100 MHz. Above 100 MHz, performance is the same for both LFE enabled or disabled. For LFE enabled performance ≤ 100 MHz, see Table 6g and 6h.

Table 6b. Source Match (dB)

Description	Specification		Typical	
	Options 201, 21x, 22x, 401, 41x, 42x	Option 029	Options 201, 21x, 22x, 401, 41x, 42x	Option 029
	All Ports	Ports 1, 2	All Ports	Ports 1, 2
10 MHz to 50 MHz ¹	10 (7)	10	13 (11)	13
50 MHz to 200 MHz ¹	18 (6)	18	27 (10)	27
200 MHz to 500 MHz	18 (6)	18	21 (8)	27
500 MHz to 3.2 GHz	16 (7)	16	20 (8)	21
3.2 GHz to 10 GHz	14 (9)	13	17 (13)	20
10 GHz to 13.5 GHz	12 (10)	12	17 (14)	17
13.5 GHz to 16 GHz	12 (10)	12	18 (16)	17
16 GHz to 20 GHz	12 (8)	11	16 (11)	18
20 GHz to 24 GHz	11 (8)	10	17 (11)	16
24 GHz to 26.5 GHz	11 (7)	9	12 (10)	15
26.5 GHz to 35 GHz	7 (7)	7	12 (10)	12
35 GHz to 43.5 GHz	7 (7)	7	13 (8)	12
43.5 GHz to 46 GHz	7 (7)	7	13 (9)	13
46 GHz to 47 GHz	6 (6)	6	11 (11)	11
47 GHz to 50 GHz	6 (6)	6	13 (8)	11

() With Option 425 installed.

¹ With Option 425 installed and LFE disabled, applied to frequencies \leq 100 MHz. Above 100 MHz, performance is the same for both LFE enabled or disabled. For LFE enabled performance \leq 100 MHz, see Table 6g and 6h.

Table 6c. Load Match (dB)

Description	Specification		Typical	
	Options 201, 21x, 22x, 401, 41x, 42x	Option 029	Options 201, 21x, 22x, 401, 41x, 42x	Option 029
	All Ports	Ports 1, 2	All Ports	Ports 1, 2
10 MHz to 50 MHz	10 (8)	10	15 (10)	15
50 MHz to 200 MHz	16 (7)	16	22 (9)	22
200 MHz to 500 MHz	16 (7)	16	18 (8)	22
500 MHz to 3.2 GHz	14 (6)	13	17 (8)	18
3.2 GHz to 10 GHz	13 (6)	11	16 (12)	17
10 GHz to 13.5 GHz	11 (8)	11	15 (13)	16
13.5 GHz to 16 GHz	11 (8)	11	16 (13)	15
16 GHz to 20 GHz	11 (7)	11	16 (12)	16
20 GHz to 24 GHz	10 (6)	8	16 (11)	16
24 GHz to 26.5 GHz	10 (6)	8	12 (11)	16
26.5 GHz to 46 GHz	7 (6)	7	12 (10)	12
46 GHz to 47 GHz	7 (6)	6	11 (13)	11
47 GHz to 50 GHz	7 (6)	6	15 (11)	11

() With Option 425 installed.

¹ With Option 425 installed and LFE disabled, applied to frequencies ≤ 100 MHz. Above 100 MHz, performance is the same for both LFE enabled or disabled. For LFE enabled performance ≤ 100 MHz, see Table 6g and 6h.

Table 6d. Reflection /Transmission Tracking, Crosstalk (dB), All Options, All Ports-Typical

Description	Reflection Tracking	Transmission Tracking	Cross-talk
10 MHz to 50 MHz	± 1.5	± 1.5	-82
50 MHz to 100 MHz	± 1.5	± 1.5	-85
100 MHz to 500 MHz	± 1.5	± 1.5	-110
500 MHz to 26.5 GHz	± 1.5	± 1.5	-120
26.5 GHz to 35 GHz	$\pm 1.5^1$	± 1.5	-120
35 GHz to 43.5 GHz	$\pm 1.5^1$	± 1.5	-115
43.5 GHz to 46 GHz	± 1.5	± 1.5	-115
46 GHz to 47 GHz	± 1.5	± 1.5	-105
46 GHz to 50 GHz	± 1.5	± 1.5	-100

¹ Reflection tracking from 26.5 GHz to 43.5 GHz with Option 029 is degraded to $\pm 1.5/-7$.

Table 6e. Noise Mode¹ Uncorrected System Performance (dB), Option 029 - Specification

Description	Source Match		Load Match	
	Port 1	Port 2	Port 1	Port 2
10 MHz to 50 MHz	4	5	4	5
50 MHz to 200 MHz	9	17	10	16
200 MHz to 500 MHz	9	17	10	16
500 MHz to 3.2 GHz	10	16	10	14
3.2 GHz to 10 GHz	10	14	9	13
10 GHz to 16 GHz	10	12	9	11
16 GHz to 20 GHz	8	10	9	10
20 GHz to 24 GHz	8	8	9	8
24 GHz to 26.5 GHz	8	8	9	6
26.5 GHz to 50 GHz	6	6	6	6

¹Noise mode sets port 1 impedance tuner switch to tuner position and port 2 noise receiver switch to noise receiver position.

Table 6f. Noise Mode¹ Uncorrected System Performance (dB), Option 029 - Typical

Description	Source Match		Load Match		Reflection Tracking		Transmission Tracking
	Port 1	Port 2	Port 1	Port 2	Port 1	Port 2	Ports 1, 2
10 MHz to 50 MHz	5	7	6	6	-1.5/-6	±2.5	±1.5
50 MHz to 500 MHz	12	25	12	22	-1.5/-6	±1.5	±1.5
500 MHz to 3.2 GHz	12	21	12	18	-1.5/-6	±1.5	±1.5
3.2 GHz to 10 GHz	14	20	14	17	-1.5/-6	±1.5	±1.5
10 GHz to 13.5 GHz	15	17	15	16	-1.5/-6	±1.5	±1.5
13.5 GHz to 16 GHz	19	17	15	15	-1.5/-6	±1.5	±1.5
16 GHz to 20 GHz	17	18	16	16	-4/-10	±1.5	±1.5
20 GHz to 24 GHz	16	16	16	16	-4/-10	±1.5	±1.5
24 GHz to 26.5 GHz	15	15	16	15	-4/-10	±1.5	±1.5
26.5 GHz to 43.5 GHz	12	12	12	12	-4/-8	±2.5	±1.5
43.5 GHz to 46 GHz	13	13	12	12	-6/-9	±3	±1.5
46 GHz to 50 GHz	11	11	11	11	-6/-9	±3	±1.5

¹Noise mode sets port 1 impedance tuner switch to tuner position and port 2 noise receiver switch to noise receiver position.

Table 6g. LFE Enabled Uncorrected System Performance, All Ports (Option 425) - Specifications

Description	Directivity	Source Match	Load Match	Transmission Tracking	Reflection Tracking	Crosstalk
1 kHz to 10 kHz	1	7	7	--	--	--
10 kHz to 1 MHz	16	15	19	--	--	--
1 MHz to 5 MHz	16	9	11	--	--	--
5 MHz to 50 MHz	5	7	8	--	--	--
50 MHz to 100 MHz	5	8	9	--	--	--

Table 6h. LFE Enabled Uncorrected System Performance, All Ports (Option 425) - Typical

Description	Directivity	Source Match	Load Match	Transmission Tracking	Reflection Tracking	Crosstalk
500 Hz to 900 Hz	--	--	--	--	--	-103
900 Hz to 1 kHz	4	8	9	±1.5	±1.5	-105
1 kHz to 10 kHz	5	9	8	±1.5	±1.5	-99
10 kHz to 100 kHz	23	19	23	±1.5	±1.5	-105
100 kHz to 1 MHz	23	19	23	±1.5	±1.5	-125
1 MHz to 5 MHz	26	13	14	±1.5	±1.5	-119
5 MHz to 10 MHz	11	9	10	±1.5	±1.5	-120
10 MHz to 50 MHz	11	9	10	±1.5	±1.5	-117
50 MHz to 100 MHz	11	11	11	±1.5	±1.5	-118

Test Port Output

See [Block diagrams](#) for all models and options.

With option 029, port 1 tuner switch is in bypass position and port 2 noise receiver switch is in normal position unless specified.

Table 7. Frequency Information, All Options

Description	Specification	Typical
N5244B Frequency Range	10 MHz to 43.5 GHz	--
N5245B Frequency Range	10 MHz to 50.0 GHz	--
N5245B Frequency Range (Option 425)	900 Hz to 50.0 GHz	500Hz to 900 Hz
Frequency Resolution	1 Hz	--
Frequency Accuracy	± 1 ppm	--
Frequency Stability	--	± 0.05 ppm, -10° to 70° C ¹ ± 0.1 ppm/yr maximum ²

¹ Assumes no variation in time.

² Assumes no variation in temperature.

Table 8a. Maximum Leveled Power (dBm), Options 201 or 401

Description	Specification			Typical		
	Ports 1, 3 ¹		Ports 2, 4 ¹	Ports 1, 3 ¹		Ports 2, 4 ¹
	Filtered Mode ²	Hi Power Mode ²		Filtered Mode ²	Hi Power Mode ²	
10 MHz to 50 MHz	4	12	12	12	20	19
50 MHz to 500 MHz	8	13	13	13	20	20
500 MHz to 1 GHz	8	13	13	14	19	19
1 GHz to 2 GHz	8	13	13	14	17	19
2 GHz to 3.2 GHz	8	10	13	14	15	19
3.2 GHz to 10 GHz	13	13	13	19	19	19
10 GHz to 16 GHz	13	13	13	18	18	17
16 GHz to 26.5 GHz	13	13	13	17	17	17
26.5 GHz to 30 GHz	12	12	12	17	17	17
30 GHz to 32 GHz	11	11	11	16	16	16
32 GHz to 35 GHz	12	12	12	17	17	17
35 GHz to 43.5 GHz	9	9	9	13	13	13
43.5 GHz to 47 GHz	5	5	5	11	11	11
47 GHz to 50 GHz	-5	-5	-5	2	2	2

¹ Either port can be used as the source port.

² In Filtered Mode, the signal path goes through filters to minimize harmonics below 3.2 GHz. In Hi Power Mode, the signal bypasses the filters to maximize output power.

Table 8b. Maximum Leveled Power (dBm), Options 21x or 41x

Description	Specification			Typical		
	Ports 1, 3 ¹		Ports 2, 4 ¹	Ports 1, 3 ¹		Ports 2, 4 ¹
	Filtered Mode ²	Hi Power Mode ²		Filtered Mode ²	Hi Power Mode ²	
10 MHz to 50 MHz	4	9	12	13	20	19
50 MHz to 500 MHz	8	13	13	13	20	20
500 MHz to 1 GHz	8	13	13	14	19	20
1 GHz to 2 GHz	8	12	13	12	17	19
2 GHz to 3.2 GHz	8	10	13	15	15	17
3.2 GHz to 10 GHz	13	13	13	18	18	18
10 GHz to 16 GHz	11	11	11	16	16	16
16 GHz to 26.5 GHz	10	10	10	15	15	15
26.5 GHz to 30 GHz	9	9	9	15	15	15
30 GHz to 32 GHz	7	7	7	13	13	13
32 GHz to 35 GHz	9	9	9	14	14	14
35 GHz to 43.5 GHz	4	4	4	9	9	9
43.5 GHz to 47 GHz	-1	-1	-1	6	6	6
47 GHz to 50 GHz	-11	-11	-11	-5	-5	-5

¹ Either port can be used as the source port.

² In Filtered Mode, the signal path goes through filters to minimize harmonics below 3.2 GHz. In Hi Power Mode, the signal bypasses the filters to maximize output power.

Table 8c. Maximum Leveled Power (dBm), Options 22x or 42x (except 425)

Description	Specification			Typical		
	Ports 1, 3 ¹		Ports 2, 4 ¹	Ports 1, 3 ¹		Ports 2, 4 ¹
	Filtered Mode ²	Hi Power Mode ²		Filtered Mode ²	Hi Power Mode ²	
10 MHz to 50 MHz	4	11	10	13	20	19
50 MHz to 500 MHz	8	13	13	13	20	20
500 MHz to 1 GHz	8	13	13	13	18	19
1 GHz to 2 GHz	8	13	13	12	17	18
2 GHz to 3.2 GHz	8	10	13	12	14	17
3.2 GHz to 10 GHz	13	13	13	18	18	18
10 GHz to 16 GHz	11	11	11	16	16	15
16 GHz to 26.5 GHz	10	10	10	14	14	14
26.5 GHz to 30 GHz	9	9	9	14	14	14
30 GHz to 32 GHz	7	7	7	13	13	13
32 GHz to 35 GHz	9	9	9	13	13	13
35 GHz to 43.5 GHz	4	4	4	9	9	8
43.5 GHz to 47 GHz	-2	-2	-2	6	6	6
47 GHz to 50 GHz	-12	-12	-12	-4	-4	-3

¹ Either port can be used as the source port.

² In Filtered Mode, the signal path goes through filters to minimize harmonics below 3.2 GHz. In Hi Power Mode, the signal bypasses the filters to maximize output power.

Table 8d. Maximum Levelled Power (dBm), Option 425

Description	Specification			Typical		
	Ports 1, 3 ¹		Ports 2, 4 ¹	Ports 1, 3 ¹		Ports 2, 4 ¹
	Filtered Mode ²	Hi Power Mode ²		Filtered Mode ²	Hi Power Mode ²	
10 MHz to 50 MHz ³	-3	4	3	6	12	12
50 MHz to 500 MHz ³	3	8	8	7	14	14
500 MHz to 1 GHz	3	8	8	7	13	13
1 GHz to 2 GHz	6	11	11	9	15	15
2 GHz to 3.2 GHz	6	8	11	9	12	12
3.2 GHz to 10 GHz	11	11	11	15	15	15
10 GHz to 16 GHz	9	9	9	13	13	13
16 GHz to 26.5 GHz	8	8	8	13	13	13
26.5 GHz to 30 GHz	7	7	7	13	13	13
30 GHz to 32 GHz	6	6	6	12	12	12
32 GHz to 35 GHz	8	8	8	13	13	13
35 GHz to 43.5 GHz	4	4	4	10	10	10
43.5 GHz to 47 GHz	-2	-2	-2	6	6	6
47 GHz to 50 GHz	-12	-12	-12	-4	-4	-3

¹ Either port can be used as the source port.

² In Filtered Mode, the signal path goes through filters to minimize harmonics below 3.2 GHz. In Hi Power Mode, the signal bypasses the filters to maximize output power.

³ With Option 425 installed and LFE disabled, applied to frequencies \leq 100 MHz. Above 100 MHz, performance is the same for both LFE enabled or disabled. For LFE enabled performance \leq 100 MHz, see Table 8g.

Table 8e. Maximum Levelled Power (dBm), Options 22x or 42x (except 425), Combine Mode - Typical

Description	Source 1 Port 1		Source 2 Port 1	
	Filtered Mode ¹	Hi Power Mode ¹	Filtered Mode ¹	Hi Power Mode ¹
10 MHz to 50 MHz	6	13	7	13
50 MHz to 1 GHz	6	11	6	11
1 GHz to 2 GHz	6	10	6	9
2 GHz to 3.2 GHz	6	6	7	6
3.2 GHz to 10 GHz	10	10	9	9
10 GHz to 16 GHz	7	7	7	7
16 GHz to 26.5 GHz	3	3	3	3
26.5 GHz to 35 GHz	1	1	0	0
35 GHz to 43.5 GHz	-3	-3	-5	-5
43.5 GHz to 47 GHz	-6	-6	-10	-10
47 GHz to 50 GHz	-17	-17	-21	-21

¹ In Filtered Mode, the signal path goes through filters to minimize harmonics below 3.2 GHz. In Hi Power Mode, the signal bypasses the filters to maximize output power.

Table 8f. Maximum Levelled Power (dBm), Option 425, Combine Mode - Typical

Description	Source 1 Port 1		Source 2 Port 1	
	Filtered Mode ¹	Hi Power Mode ¹	Filtered Mode ¹	Hi Power Mode ¹
10 MHz to 50 MHz ²	-1	6	-1	6
50 MHz to 1 GHz ²	1	6	1	6
1 GHz to 2 GHz	4	8	4	7
2 GHz to 3.2 GHz	4	4	5	4
3.2 GHz to 10 GHz	8	8	7	7
10 GHz to 16 GHz	5	5	5	5
16 GHz to 26.5 GHz	2	2	2	2
26.5 GHz to 35 GHz	-1	-1	-2	-2
35 GHz to 43.5 GHz	-2	-2	-2	-2
43.5 GHz to 47 GHz	-7	-7	-7	-7
47 GHz to 50 GHz	-18	-18	-18	-18

¹ In Filtered Mode, the signal path goes through filters to minimize harmonics below 3.2 GHz. In Hi Power Mode, the signal bypasses the filters to maximize output power.

² With Option 425 installed and LFE disabled, applied to frequencies \leq 100 MHz. Above 100 MHz, performance is the same for both LFE enabled or disabled. For LFE enabled performance \leq 100 MHz, see Table 8g.

Table 8g. Maximum Power (dBm), All Ports, Option 425 (LFE Enabled), Combine Mode - Typical

Description	Source 1 Port 1	Source 2 Port 1
500 Hz to 900 Hz	6	5
900 Hz to 1 kHz	7	6
1 kHz to 100 kHz	7	6
100 kHz to 1 MHz	8	7
1 MHz to 5 MHz	7	6
5 MHz to 10 MHz	5	4
10 MHz to 50 MHz	5	4
50 MHz to 100 MHz	5	4

Table 8h. Maximum Levelled Power (dBm), Option 22x

Description	Specification			Typical		
	Source 2 Out 1		Source 2 Out 2	Source 2 Out 1		Source 2 Out 2
	Filtered Mode ¹	Hi Power Mode ¹		Filtered Mode ¹	Hi Power Mode ¹	
10 MHz to 50 MHz	4	13	13	13	20	19
50 MHz to 500 MHz	8	18	15	13	20	20
500 MHz to 1 GHz	8	16	13	14	19	20
1 GHz to 2 GHz	8	13	13	13	18	20
2 GHz to 3.2 GHz	8	11	13	13	16	18
3.2 GHz to 10 GHz	14	14	16	20	20	20
10 GHz to 16 GHz	12	12	13	19	19	18
16 GHz to 26.5 GHz	14	14	14	19	19	19
26.5 GHz to 30 GHz	14	14	14	19	19	19
30 GHz to 32 GHz	13	13	14	18	18	19
32 GHz to 35 GHz	14	14	14	19	19	19
35 GHz to 43.5 GHz	11	11	12	15	15	16
43.5 GHz to 47 GHz	7	7	8	13	13	14
47 GHz to 50 GHz	-2	-2	-2	5	5	8

¹ In Filtered Mode, the signal path goes through filters to minimize harmonics below 3.2 GHz. In Hi Power Mode, the signal bypasses the filters to maximize output power.

Table 8i. Maximum Levelled Power (dBm), Options 22x or 42x with 029¹

Description	Specification			Typical		
	Port 1		Port 2	Port 1		Port 2
	Filtered Mode ²	Hi Power Mode ²		Filtered Mode ²	Hi Power Mode ²	
10 MHz to 50 MHz	4	11	10	11	18	19
50 MHz to 500 MHz	8	13	13	11	18	19
500 MHz to 1 GHz	8	13	13	10	18	16
1 GHz to 2 GHz	8	13	13	10	16	16
2 GHz to 3.2 GHz	8	10	13	10	13	16
3.2 GHz to 10 GHz	13	13	13	16	16	16
10 GHz to 16 GHz	10	10	10	13	13	13
16 GHz to 26.5 GHz	8	8	8	13	13	13
26.5 GHz to 30 GHz	7	7	7	13	13	13
30 GHz to 32 GHz	5	5	5	11	11	11
32 GHz to 35 GHz	7	7	7	13	13	13
35 GHz to 43.5 GHz	1	1	1	8	8	8
43.5 GHz to 47 GHz	-4	-4	-4	4	4	5
47 GHz to 50 GHz	-15	-15	-15	-7	-7	-6

¹ Option 029 affects port 1 and port 2 maximum levelled power. Refer to Table 8c and 8e for other ports.

² In Filtered Mode, the signal path goes through filters to minimize harmonics below 3.2 GHz. In Hi Power Mode, the signal bypasses the filters to maximize output power.

Table 8j. Maximum Leveled Power (dBm), Options 22x or 42x with 029¹, Combine Mode-Typical

Description	Source 1 Port 1		Source 2 Port 1	
	Filtered Mode ²	Hi Power Mode ²	Filtered Mode ²	Hi Power Mode ²
10 MHz to 50 MHz	4	11	5	11
50 MHz to 1 GHz	4	11	4	11
1 GHz to 2 GHz	4	9	4	8
2 GHz to 3.2 GHz	4	5	4	5
3.2 GHz to 10 GHz	8	8	7	7
10 GHz to 16 GHz	4	4	4	4
16 GHz to 26.5 GHz	2	2	2	2
26.5 GHz to 35 GHz	1	1	0	0
35 GHz to 43.5 GHz	-4	-4	-5	-5
43.5 GHz to 47 GHz	-8	-8	-10	-10
47 GHz to 50 GHz	-20	-20	-24	-24

¹ Option 029 affects port 1 and port 2 maximum leveled power. Refer to Table 8c and 8e for other ports.

² In Filtered Mode, the signal path goes through filters to minimize harmonics below 3.2 GHz. In Hi Power Mode, the signal bypasses the filters to maximize output power.

Table 8k. Maximum Levelled Power (dBm), Noise Mode¹, Options 22x or 42x with 029¹ – Typical

Description	Port 1				Source 2 Port 1		Port 2
	Normal Mode		Combine Mode		Combine Mode		
	Filtered Mode ²	Hi Power Mode ²	Filtered Mode ²	Hi Power Mode ²	Filtered Mode ²	Hi Power Mode ²	
10 MHz to 50 MHz	5	12	-2	5	-1	5	6
50 MHz to 500 MHz	7	14	0	7	0	7	10
500 MHz to 1 GHz	6	14	0	7	0	7	7
1 GHz to 2 GHz	6	12	0	5	0	4	7
2 GHz to 3.2 GHz	6	9	0	1	0	1	6
3.2 GHz to 10 GHz	11	11	3	3	2	2	6
10 GHz to 16 GHz	7	7	-2	-2	-2	-2	3
16 GHz to 26.5 GHz	6	6	-5	-5	-5	-5	2
26.5 GHz to 30 GHz	7	7	-5	-5	-6	-6	-7
30 GHz to 32 GHz	4	4	-6	-6	-7	-7	1
32 GHz to 35 GHz	6	6	-6	-6	-7	-7	-7
35 GHz to 43.5 GHz	1	1	-11	-11	-12	-12	-2
43.5 GHz to 47 GHz	-4	-4	-16	-16	-18	-18	-4
47 GHz to 50 GHz	-15	-15	-28	-28	-32	-32	-16

¹ Noise mode sets port 1 tuner switch to tuner position and port 2 noise receiver switch to noise receiver position.

² In Filtered Mode, the signal path goes through filters to minimize harmonics below 3.2 GHz. In Hi Power Mode, the signal bypasses the filters to maximize output power.

Table 8l. Maximum Power (dBm), All Ports – Option 425 (LFE Enabled)

Description	Specification	Typical
500 Hz to 900 Hz	--	12
900 Hz to 1 kHz	10	13
1 kHz to 100 kHz	12	13
100 kHz to 1 MHz	12	14
1 MHz to 5 MHz	10	13
5 MHz to 10 MHz	9	11
10 MHz to 50 MHz	8	10
50 MHz to 100 MHz	8	10

Table 9a. Power Level Accuracy (dB) at Nominal Power¹, All Options

Description	Specification		Typical	
	Ports 1, 2, 3, 4 ²	Source 2 Out 1 Source 2 Out 2	Ports 1, 2, 3, 4 ²	Source 2 Out 1 Source 2 Out 2
10 MHz to 50 MHz ³	± 1.5	± 2.5	± 0.27	± 0.30
50 MHz to 1 GHz ³	± 1.2	± 2.0	± 0.24	± 0.26
1 GHz to 3.2 GHz	± 1.2	± 2.0	± 0.33	± 0.20
3.2 GHz to 13.5 GHz	± 1.5	± 2.0	± 0.33	± 0.20
13.5 GHz to 20 GHz	± 1.5	± 2.5	± 0.36	± 0.52
20 GHz to 26.5 GHz	± 2.0	± 2.5	± 0.47	± 0.44
26.5 GHz to 43.5 GHz	± 3.0	± 3.5	± 0.25	± 0.27
43.5 GHz to 50 GHz	± 3.5	± 3.5	± 0.97	± 0.82

¹ Level accuracy at power other than nominal power, Power Level Accuracy (dB) at Nominal Power + Power Level Linearity (dB)

² Any port can be used as the source port. Source in filtered mode where applicable.

³ With Option 425 installed and LFE disabled, applied to frequencies ≤ 100 MHz. Above 100 MHz, performance is the same for both LFE enabled or disabled. For LFE enabled performance ≤ 100 MHz, see Table 9b.

Table 9b. Power Level Accuracy (dB), All Ports, Option 425 (LFE Enabled)

Description	Specification	Typical
500 Hz to 900 Hz	--	± 0.1
900 Hz to 1 kHz	± 1.0	± 0.1
1 kHz to 100 kHz	± 1.0	± 0.1
100 kHz to 1 MHz	± 1.0	± 0.15
1 MHz to 5 MHz	± 1.0	± 0.15
5 MHz to 10 MHz	± 1.0	± 0.2
10 MHz to 50 MHz	± 1.0	± 0.2
50 MHz to 100 MHz	± 1.0	± 0.2

Table 10a. Power Level Linearity¹ (dB), All Options - Specification

Description	Ports 1, 3 ²		Ports 1, 3 ²
	-25 dBm ≤ P < -20 dBm	-20 dBm ≤ P < -15 dBm	P ≥ -15 dBm
10 MHz to 50 GHz ³	± 1.5	± 1.5	± 1.5

¹ Referenced to nominal power.

² Either port can be used as the source port. Source in filtered mode.

³ With Option 425 installed and LFE disabled, applied to frequencies ≤ 100 MHz. Above 100 MHz, performance is the same for both LFE enabled or disabled. For LFE enabled performance ≤ 100 MHz, see Table 10d.

Table 10b. Power Level Linearity¹ (dB), All Options - Specification

Description	Ports 2, 4 ² -25 dBm ≤ P < -20 dBm	Ports 2, 4 ² -20 dBm ≤ P < -15 dBm	Ports 2, 4 ² P ≥ -15 dBm
10 MHz to 50 GHz ³	± 2.0	± 1.5	± 1.5

¹ Referenced to nominal power.

² Either port can be used as the source port.

³ With Option 425 installed and LFE disabled, applied to frequencies ≤ 100 MHz. Above 100 MHz, performance is the same for both LFE enabled or disabled. For LFE enabled performance ≤ 100 MHz, see Table 10d.

Table 10c. Power Level Linearity¹ (dB), Option 22x - Specification

Description	Source 2 Out 1 ² P ≥ -15 dBm	Source 2 Out 2 -15 dBm ≤ P < -10 dBm	Source 2 Out 2 P ≥ -10 dBm
10 MHz to 50 GHz ³	± 1.0	± 1.0	± 1.0

¹ Referenced to nominal power.

² Source in filtered mode.

³ With Option 425 installed and LFE disabled, applied to frequencies ≤ 100 MHz. Above 100 MHz, performance is the same for both LFE enabled or disabled. For LFE enabled performance ≤ 100 MHz, see Table 10d.

Table 10d. Power Level Linearity¹ (dB), All Ports, Option 425 (LFE Enabled)

Description	Specification
500 Hz to 900 Hz	--
900 Hz to 100 MHz	±1.0

¹ Referenced to nominal power, from -25 dBm to max power.

Table 11a. Power Sweep Range (dB), Options 201 or 401

Description	Specification		Typical	
	Ports 1, 3 ¹	Ports 2, 4 ¹	Ports 1, 3 ¹	Ports 2, 4 ¹
10 MHz to 50 MHz	37	37	47	46
50 MHz to 500 MHz	38	38	47	47
500 MHz to 1 GHz	38	38	46	46
1 GHz to 2 GHz	38	38	44	46
2 GHz to 3.2 GHz	35	38	42	46
3.2 GHz to 10 GHz	38	38	46	46
10 GHz to 16 GHz	38	38	45	44
16 GHz to 26.5 GHz	38	38	43	44
26.5 GHz to 30 GHz	37	37	44	44
30 GHz to 32 GHz	36	36	43	43
32 GHz to 35 GHz	37	37	44	44
35 GHz to 43.5 GHz	34	34	40	40
43.5 GHz to 47 GHz	30	30	38	38
47 GHz to 50 GHz	20	20	29	29

¹ Either port can be used as the source port. Source in Hi Power mode where applicable.

Table 11b. Power Sweep Range (dB), Options 21x or 41x

Description	Specification		Typical	
	Ports 1, 3 ¹	Ports 2, 4 ¹	Ports 1, 3 ¹	Ports 2, 4 ¹
10 MHz to 50 MHz	34	37	47	46
50 MHz to 500 MHz	38	38	47	47
500 MHz to 1 GHz	38	38	46	47
1 GHz to 2 GHz	37	38	44	46
2 GHz to 3.2 GHz	35	38	42	44
3.2 GHz to 10 GHz	38	38	45	45
10 GHz to 16 GHz	36	36	43	43
16 GHz to 26.5 GHz	35	35	42	42
26.5 GHz to 30 GHz	34	34	42	42
30 GHz to 32 GHz	32	32	40	40
32 GHz to 35 GHz	34	34	41	41
35 GHz to 43.5 GHz	29	29	36	36
43.5 GHz to 47 GHz	24	24	33	33
47 GHz to 50 GHz	14	14	22	22

¹ Either port can be used as the source port. Source in Hi Power mode where applicable.

Table 11c. Power Sweep Range (dB), Options 22x or 42x (except 425)

Description	Specification		Typical	
	Ports 1, 3 ¹	Ports 2, 4 ¹	Ports 1, 3 ¹	Ports 2, 4 ¹
10 MHz to 50 MHz	36	35	47	46
50 MHz to 500 MHz	38	38	47	47
500 MHz to 1 GHz	38	38	45	46
1 GHz to 2 GHz	38	38	44	45
2 GHz to 3.2 GHz	35	38	41	44
3.2 GHz to 10 GHz	38	38	45	45
10 GHz to 16 GHz	36	36	43	42
16 GHz to 26.5 GHz	35	35	41	41
26.5 GHz to 30 GHz	34	34	41	41
30 GHz to 32 GHz	32	32	40	40
32 GHz to 35 GHz	34	34	40	40
35 GHz to 43.5 GHz	29	29	36	35
43.5 GHz to 47 GHz	23	23	33	33
47 GHz to 50 GHz	13	13	23	24

¹ Either port can be used as the source port. Source in Hi Power mode where applicable.

Table 11d. Power Sweep Range (dB), Option 22x

Description	Specification		Typical	
	Source 2 Out 1 ¹	Source 2 Out 2	Source 2 Out 1 ¹	Source 2 Out 2
10 MHz to 50 MHz	28	28	37	36
50 MHz to 500 MHz	33	30	37	37
500 MHz to 1 GHz	31	28	36	37
1 GHz to 2 GHz	28	28	35	37
2 GHz to 3.2 GHz	26	28	33	35
3.2 GHz to 10 GHz	29	31	37	37
10 GHz to 16 GHz	27	28	36	35
16 GHz to 26.5 GHz	29	29	36	36
26.5 GHz to 30 GHz	29	29	36	36
30 GHz to 32 GHz	28	29	35	36
32 GHz to 35 GHz	29	29	36	36
35 GHz to 43.5 GHz	26	27	32	33
43.5 GHz to 47 GHz	22	23	30	31
47 GHz to 50 GHz	13	13	22	25

¹ Source in Hi Power mode where applicable.

Table 11e. Power Sweep Range (dB), Options 22x or 42x (except 425) with 029¹

Description	Specification		Typical	
	Port 1 ²	Port 2	Port 1 ²	Port 2
10 MHz to 50 MHz	36	35	45	46
50 MHz to 500 MHz	38	38	45	46
500 MHz to 1 GHz	38	38	45	43
1 GHz to 2 GHz	38	38	43	43
2 GHz to 3.2 GHz	35	38	40	43
3.2 GHz to 10 GHz	38	38	43	43
10 GHz to 16 GHz	35	35	40	40
16 GHz to 26.5 GHz	33	33	40	40
26.5 GHz to 30 GHz	30	32	40	40
30 GHz to 32 GHz	30	30	38	38
32 GHz to 35 GHz	32	32	40	40
35 GHz to 43.5 GHz	26	26	35	35
43.5 GHz to 47 GHz	21	21	31	32
47 GHz to 50 GHz	10	10	20	21

¹ Option 029 affects port 1 and port 2 power sweep ranges. Refer to Table 11c and 11d for other ports.

² Source in Hi Power mode where applicable.

Table 11f. Power Sweep Range (dB), Option 425

Description	Specification (dBm)		Typical (dBm)	
	Port 1, 3	Port 2, 4	Port 1, 3	Port 2, 4
10 MHz to 50 MHz ¹	29	28	39	39
50 MHz to 500 MHz ¹	33	33	41	41
500 MHz to 1 GHz	33	33	40	40
1 GHz to 2 GHz	36	36	42	42
2 GHz to 3.2 GHz	33	36	39	39
3.2 GHz to 10 GHz	36	36	42	42
10 GHz to 16 GHz	34	34	40	40
16 GHz to 26.5 GHz	33	33	40	40
26.5 GHz to 30 GHz	32	32	40	40
30 GHz to 32 GHz	31	31	39	39
32 GHz to 35 GHz	33	33	40	40
35 GHz to 43.5 GHz	29	29	37	37
43.5 GHz to 47 GHz	23	23	33	33
47 GHz to 50 GHz	13	13	23	24

¹ With Option 425 installed and LFE disabled, applied to frequencies \leq 100 MHz. Above 100 MHz, performance is the same for both LFE enabled or disabled. For LFE enabled performance \leq 100 MHz, see Table 11g.

Table 11g. Power Sweep Range (dB) –Option 425 (LFE Enabled)

Description	Specification	Typical
500 Hz to 900 Hz	--	39
900 Hz to 1 kHz	35	40
1 kHz to 100 kHz	37	40
100 kHz to 1 MHz	37	41
1 MHz to 5 MHz	35	40
5 MHz to 10 MHz	34	38
10 MHz to 50 MHz	33	37
50 MHz to 100 MHz	33	37

Table 12. Nominal Power (Preset Power, dBm)

Description	Specification			Typical	
	All Options	Option 22x		Options 22x, 42x	
	Ports 1, 2, 3, 4 ¹	Source 2 Out 1	Source 2 Out 2	Source 1 Port 1 Combine Mode	Source 2 Port 1 Combine Mode
N5244B	-5	-5	-5	-15	-15
N5245B	-15	-5	-5	-25	-30

¹ Any port can be used as the source port.

Table 13. Power Resolution and Maximum/Minimum Settable Power, All Ports¹

Description	Specification (dB)	Typical (dBm)		
	All Options	All Options	Options 201, 401	Options 21x, 41x, 22x, 42x
Power Resolution	0.01	--	--	--
Maximum Settable Power	--	30	--	--
Minimum Settable Power	--	--	-30	-90

¹ Any port can be used as the source port.

Table 14a. 2nd and 3rd Harmonics at Max Specified Power (dBc), All Options - Typical

Description ¹	Ports 1, 3 ² , Source 2 Out 1 ³	Ports 2, 4 ² , Source 2 Out 2
10 MHz to 2 GHz ⁴	-51	-13
2 GHz to 13.5 GHz	-60	-21
13.5 GHz to 50 GHz	-60	-60

¹ Listed frequency is fundamental frequency; test at max specified power.

² Any port can be used as the source port. Source in Filtered mode where applicable.

³ At port 1 max specified power.

⁴ With Option 425 installed and LFE disabled, applied to frequencies \leq 100 MHz. Above 100 MHz, performance is the same for both LFE enabled or disabled. For LFE enabled performance \leq 100 MHz, see Table 14b.

Table14b. 2nd and 3rd Harmonics at Max Specified Power (dBc), All Ports, Option 425 (LFE Enabled) - Typical

Listed frequency is fundamental frequency; test at max specified power

Description	2nd Harmonic	3rd Harmonic
500 Hz to 900 Hz	-32	-31
900 Hz to 1 kHz	-22	-23
1 kHz to 100 kHz	-22	-23
100 kHz to 1 MHz	-25	-22
1 MHz to 5 MHz	-28	-24
5 MHz to 10 MHz	-27	-22
10 MHz to 33 MHz	-28	-21
33 MHz to 50 MHz	-28	--

Table 15. Non-Harmonic Spurs at Nominal Power (dBc), All Options - Typical

Description	Ports 1, 2, 3, 4, Source 2 Out 1, Source 2 Out 2
10 MHz to 500 MHz	-50
500 MHz to 2GHz	-60
2 GHz to 4 GHz	-57
4 GHz to 8 GHz	-51
8 GHz to 16 GHz	-45
16 GHz to 32 GHz	-39
32 GHz to 50 GHz	-31

Table 16a. Phase Noise (dBc/Hz), All Options, All Ports - Typical

Description	1 kHz Offset	10 kHz Offset	100 kHz Offset	1 MHz Offset
10 MHz to 500 MHz ¹	-85	-85	-85	-120
500 MHz to 1 GHz	-105	-115	-110	-127
1 GHz to 2 GHz	-100	-110	-105	-121
2 GHz to 4 GHz	-95	-105	-100	-115
4 GHz to 8 GHz	-89	-100	-94	-110
8 GHz to 16 GHz	-83	-94	-88	-105
16 GHz to 32 GHz	-77	-88	-82	-99
32 GHz to 50 GHz	-71	-82	-76	-93

¹ With Option 425 installed and LFE disabled, applied to frequencies \leq 100 MHz. Above 100 MHz, performance is the same for both LFE enabled or disabled. For LFE enabled performance \leq 100 MHz, see Table 16b.

Table 16b. Phase Noise (dBc/Hz), All Ports, Option 425 (LFE Enabled) - Typical

Description	1 kHz Offset	10 kHz Offset	100 kHz Offset	1 MHz Offset
500 Hz to 100 MHz	-120	-130	-125	-135

Test Port Input

Table 17a. Noise Floor¹ (dBm) @ 10 Hz IFBW, All Options, All Ports

Description	Specification		Typical	
	Test Port	Direct Receiver Access Input	Test Port	Direct Receiver Access Input
10 MHz to 50 MHz ^{2,3}	-70	-105	-76	-111
50 MHz to 100 MHz ^{2,3}	-85	-105	-91	-111
100 MHz to 500 MHz ²	-90	-110	-98	-118
500 MHz to 1 GHz	-106	-127	-112	-133
1 GHz to 2 GHz	-110	-130	-114	-134
2 GHz to 10 GHz	-110	-122	-114	-126
10 GHz to 26.5 GHz	-111	-123	-114	-126
26.5 GHz to 40 GHz	-108	-118	-113	-123
40 GHz to 43.5 GHz	-109	-119	-113	-123
43.5 GHz to 50 GHz	-107	-117	-113	-123

¹ Total average (rms) noise power calculated as the mean value of a linear magnitude trace expressed in dBm.

² May typically be degraded at particular frequencies below 500 MHz due to spurious receiver residuals.

³ With Option 425 installed and LFE disabled, applied to frequencies \leq 100 MHz. Above 100 MHz, performance is the same for both LFE enabled or disabled. For LFE enabled performance \leq 100 MHz, see Table 17b.

Table 17b. LFE Enabled Noise Floor (dBm) @ 10 Hz IFBW (Option 425)

Description	Specification	Typical
500 Hz to 900 Hz	--	-93
900 Hz to 1 kHz	-83	-96
1 kHz to 100 kHz	-91	-96
100 kHz to 1 MHz	-107	-110
1 MHz to 5 MHz	-108	-112
5 MHz to 10 MHz	-102	-106
10 MHz to 50 MHz	-102	-106
50 MHz to 100 MHz	-102	-106

Table 18a. 0.1 dB Compression, All Options, All Ports - Typical

Description	Test Port Power (dBm)
10 MHz to 10 GHz ¹	15
10 GHz to 50 GHz	13

¹ With Option 425 installed and LFE disabled, applied to frequencies \leq 100 MHz. Above 100 MHz, performance is the same for both LFE enabled or disabled. For LFE enabled performance \leq 100 MHz, see Table 18b.

Table 18b. LFE Enabled 0.1 dB Compression, All Ports (Option 425) - Typical

Description	Test Port Power (dBm)
500 Hz to 900 Hz	13
900 Hz to 1 kHz	13
1 kHz to 100 kHz	13
100 kHz to 1 MHz	13
1 MHz to 5 MHz	11
5 MHz to 10 MHz	13
10 MHz to 50 MHz	14
50 MHz to 100 MHz	14

Table 18c. LFE Enabled Compression, All Ports (Option 425) - Specification

Description	Test Port Power (dBm)	Receiver Compression	
		Magnitude (dB)	Phase (degrees)
500 Hz to 900 Hz	--	--	--
900 Hz to 1 kHz	10	0.2	1
1 kHz to 100 kHz	12	0.2	1
100 kHz to 1 MHz	12	0.2	1
1 MHz to 5 MHz	10	0.2	1
5 MHz to 10 MHz	9	0.2	1
10 MHz to 50 MHz	8	0.2	1
50 MHz to 100 MHz	8	0.2	1

Table 19. Compression, All Ports - Specification

Description	Test Port Power			Receiver compression	
	Options 201, 401	Options 21x, 41x	Options 22x, 42x	Magnitude (dB)	Phase (degree)
500 MHz to 10 GHz ¹	13	13	13	0.15	1.5
10 GHz to 13.5 GHz	13	11	10	0.15	1.5
13.5 GHz to 20 GHz	13	9	9	0.15	1.5
20 GHz to 26.5 GHz	13	9	9	0.18	1.5
26.5 GHz to 32 GHz	13	9	8	0.18	1.5
32 GHz to 40 GHz	9	8	8	0.18	1.5
40 GHz to 43.5 GHz	8	8	8	0.18	1.5
43.5 GHz to 45 GHz	8	8	8	0.2	1.5
45 GHz to 47 GHz	6	6	6	0.2	1.5
47 GHz to 50 GHz	5	1	0	0.2	1.5

¹ Test port receiver compression at input levels below 500 MHz is negligible due to coupler roll off.

Table 20a. Trace Noise¹ Magnitude (dB rms), All Options, All Ports

Description	Specification	Typical		
	1 kHz IFBW	1 kHz IFBW	100 kHz IFBW	600 kHz IFBW
10 MHz to 50 MHz ²	0.200	0.08	0.800	2.000
50 MHz to 100 MHz ²	0.020	0.013	0.120	0.300
100 MHz to 500 MHz	0.020	0.005	0.050	0.150
500 MHz to 1 GHz	0.003	0.002	0.012	0.030
1 GHz to 26.5 GHz	0.002	0.002	0.011	0.026
26.5 GHz to 43.5 GHz	0.003	0.002	0.011	0.026
43.5 GHz to 50 GHz	0.004	0.002	0.011	0.026

¹ Ratioed measurement, nominal power at test port.

² With Option 425 installed and LFE disabled, applied to frequencies \leq 100 MHz. Above 100 MHz, performance is the same for both LFE enabled or disabled. For LFE enabled performance \leq 100 MHz, see Table 20b.

Table 20b. Trace Noise¹ Magnitude (dB rms), All Ports, Option 425 (LFE Enabled)

Description	Specification		Typical			
	100 Hz IFBW	1 kHz IFBW	100 Hz IFBW	1 kHz IFBW	100 kHz IFBW	600 kHz IFBW
500 Hz to 900 Hz	--	--	0.002	--	--	--
900 Hz to 4 kHz	0.004	--	0.001	--	--	--
4 kHz to 300 kHz	--	0.004	--	0.002	--	--
300 kHz to 2 MHz	--	0.004	--	0.001	0.01	--
2 MHz to 100 MHz	--	0.004	--	0.001	0.01	0.025

¹ Ratioed measurement, -5 dBm at test port.

Table 20c. Trace Noise¹ Phase (deg rms), All Options, All Ports

Description	Specification	Typical		
	1 kHz IFBW	1 kHz IFBW	100 kHz IFBW	600 kHz IFBW
10 MHz to 50 MHz ²	1	0.6	6	14
50 MHz to 100 MHz ²	1	0.1	1	1.8
100 MHz to 500 MHz	0.5	0.035	0.35	1.0
500 MHz to 1 GHz	0.02	0.009	0.1	0.25
1 GHz to 26.5 GHz	0.02	0.009	0.08	0.18
26.5 GHz to 50 GHz	0.03	0.015	0.09	0.2

¹ Ratioed measurement, nominal power at test port.

² With Option 425 installed and LFE disabled, applied to frequencies \leq 100 MHz. Above 100 MHz, performance is the same for both LFE enabled or disabled. For LFE enabled performance \leq 100 MHz, see Table 20d.

Table 20d. Trace Noise¹ Phase (deg rms), All Ports, Option 425 (LFE Enabled)

Description	Specification		Typical			
	100 Hz IFBW	1 kHz IFBW	100 Hz IFBW	1 kHz IFBW	100 kHz IFBW	600 kHz IFBW
500 Hz to 900 Hz	--	--	0.012	--	--	--
900 Hz to 4 kHz	0.03	--	0.008	--	--	--
4 kHz to 300 kHz	--	0.03	--	0.014	--	--
300 kHz to 2 MHz	--	0.03	--	0.007	0.064	--
2 MHz to 100 MHz	--	0.03	--	0.007	0.068	0.166

¹ Ratioed measurement, -5 dBm at test port.

Table 21. Reference Level - Specification

Description	Magnitude (dB)	Phase (°)
Range	±500	±500
Resolution	0.001	0.01

Table 22a. Stability¹ - Typical

Description	Magnitude (dB/°C)	Phase (°/°C)
10 MHz to 50 MHz ²	0.02	0.3
50 MHz to 3.2 GHz ²	0.01	0.15
3.2 GHz to 10 GHz	0.01	0.2
10 GHz to 16 GHz	0.01	0.25
16 GHz to 20 GHz	0.015	0.3
20 GHz to 26.5 GHz	0.015	0.4
26.5 GHz to 32 GHz	0.02	0.55
32 GHz to 40 GHz	0.025	0.7
40 GHz to 47 GHz	0.025	0.75
47 GHz to 50 GHz	0.03	0.8

¹ Stability is defined as a ratio measurement made at the test port.

² With Option 425 installed and LFE disabled, applied to frequencies ≤ 100 MHz. Above 100 MHz, performance is the same for both LFE enabled or disabled. For LFE enabled performance ≤ 100 MHz, see Table 22b.

Table 22b. Stability¹, Option 425 (LFE Enabled) - Typical

Description	Magnitude (dB/°C)	Phase (°/°C)
500 Hz to 900 Hz	0.010	0.2
900 Hz to 1 kHz	0.010	0.2
1 kHz to 100 kHz	0.010	0.2
100 kHz to 1 MHz	0.010	0.1
1 MHz to 5 MHz	0.010	0.1
5 MHz to 10 MHz	0.010	0.1
10 MHz to 50 MHz	0.010	0.1
50 MHz to 100 MHz	0.020	0.1

¹ Stability is defined as a ratio measurement made at the test port.

Table 23 Damage Input Level - Specification

Description	RF (dBm)	DC (V)
Test Ports 1, 2, 3, 4	> +30	> 40
Source 2 Out 1, Source 2 Out 2 (Option 22x only)	> +30	> 0
Test Port 1, Noise Mode ¹ (Option 029 only)	> +10	> 40
Test Port 2, Noise Mode ¹ (Option 029 only)	> +27	> 40
Test Ports (Option 425)	> +20	> 50

¹ Noise mode sets port 1 impedance tuner switch to internal tuner position and port 2 noise receiver switch to noise receiver position.

Noise Receiver Input (Option 029 only)

Table 24. Noise Receiver Bandwidth

Description	Allowable Bandwidths
10 MHz to 25 MHz	800 kHz, 2 MHz
25 MHz to 60 MHz	800 kHz, 2/4 MHz
60 MHz to 150 MHz	800 kHz, 2/4/8 MHz ¹
150 MHz to 50 GHz	800 kHz, 2/4/8/24 MHz ¹

¹ 8 and 24 MHz bandwidths are available only with calibration using noise source.

Table 25. Receiver Noise Figure (dB), Port 2, at 4 MHz BW, High Gain Setting

Description	Specification	Typical
10 MHz to 50 MHz	--	9
50 MHz to 1.5 GHz	10	7
1.5 GHz to 5 GHz	12	10
5 GHz to 20 GHz	15	11
20 GHz to 45 GHz	16	11
45 GHz to 50 GHz	21	14

Table 26. Noise Figure Trace Noise¹ (dB rms) at 4 MHz BW, All Gain Settings

Frequency	Specification	Typical
10 MHz to 50 MHz	--	0.07
50 MHz to 50 GHz	0.11	0.07

¹ Trace noise magnitude performance on noise figure trace or sometimes called noise jitter, 201 points, 1 noise average, with terminated input. May typically be degraded at frequencies below 500 MHz due to spurious noise receiver residuals.

Table 27. Noise Receiver Linearity (dB) at 4 MHz BW - Specification

Power Range (dBm)			Specification
Low Gain Setting Reference to -60dBm	Medium Gain Setting Reference to -70 dBm	High Gain Setting Reference to -80 dBm	
-36 to -64	-48 to -76	-58 to -85	±0.05
-64 to -70	-76 to -87	-85 to -92	±0.07

Table 28. Noise Receiver Input Range - Specification

Description	Max DUT NF + Gain (dB) ¹			Max Input Power (dBm) for <0.1 dB Compression ²		
	High Gain Setting	Medium Gain Setting	Low Gain Setting	High Gain Setting	Medium Gain Setting	Low Gain Setting
500 MHz to 4.5 GHz	37	53	68	≤-51	≤-35	≤-20
4.5 GHz to 6 GHz	38	53	71	≤-50	≤-35	≤-17
6 GHz to 24 GHz	47	57	66	≤-41	≤-31	≤-22
24 GHz to 26.5 GHz	45	58	66	≤-43	≤-30	≤-22
26.5 GHz to 36 GHz	45	56	57	≤-43	≤-32	≤-31
36 GHz to 50 GHz	39	51	58	≤-49	≤-37	≤-30

¹ Limited by 0.1 dB receiver compression. Applies to devices with bandwidth <400 MHz. For devices with higher bandwidths, calculate the DUT output noise power as $-174 \text{ dBm} + 10 \cdot \log_{10}(B) + \text{Gain (dB)} + \text{NF (dB)}$, where B is the bandwidth of the DUT in Hz, and use the Max Input Power specification.

² Derived from ensuring < 0.25 dB compression with a CW signal 5 dB higher than the stated max input power value for 0.1 dB compression. Referenced to test port 2.

Dynamic Accuracy

Table 29. Dynamic Accuracy - Specification

Standard receiver accuracy of the test port input power reading relative to the reference input power level. It is verified with the following measurements:

- Compression over frequency
- IF linearity at a single frequency of 1.998765 GHz using a reference level of -20 dBm for an input power range of 0 to -60 dBm. For value below -60 dBm, refer to “VNA Receiver Dynamic Accuracy Specifications and Uncertainties”.

Applies to the N5244B and N5245B with the following serial numbers.

N5244B and N5244BS: MY5244/SG5244/US5244 and above

N5245B and N5245BS: MY5245/SG5245/US5245 and above

Please download our free Uncertainty Calculator from http://www.keysight.com/find/na_calculator to generate the curves for your PNA.

Dynamic Accuracy, 900 Hz (LFE Enabled) - Specification

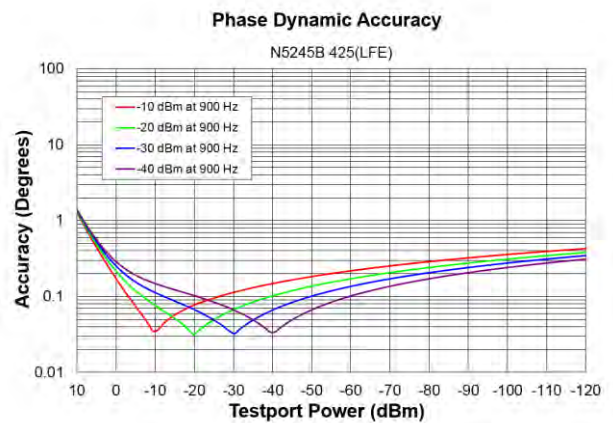
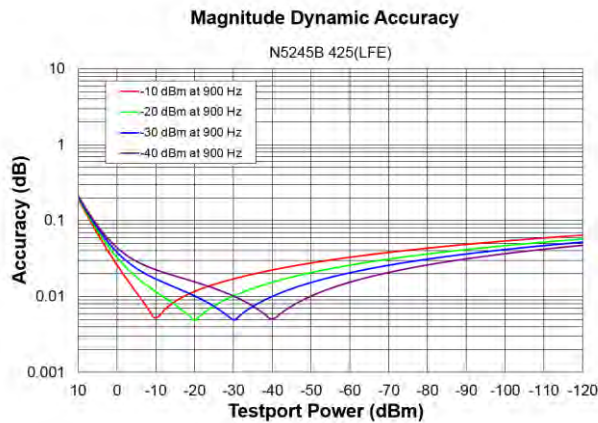

Dynamic Accuracy, 10 MHz (LFE Enabled) - Specification

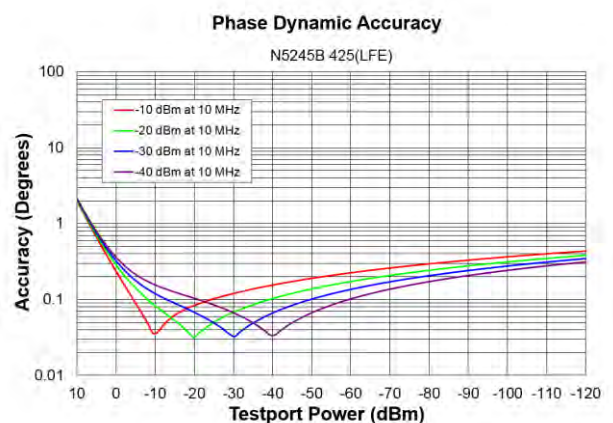
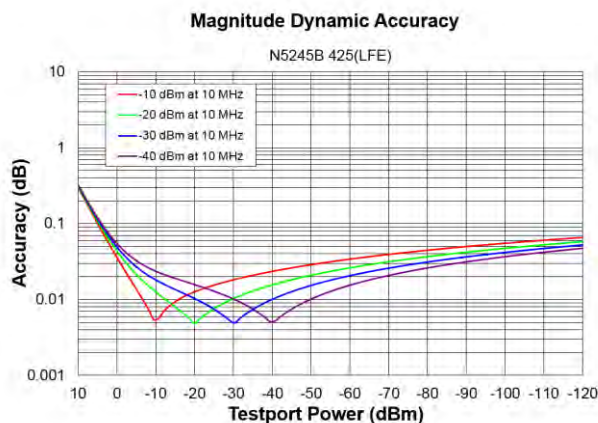

Dynamic Accuracy, 100 MHz (LFE Enabled) - Specification

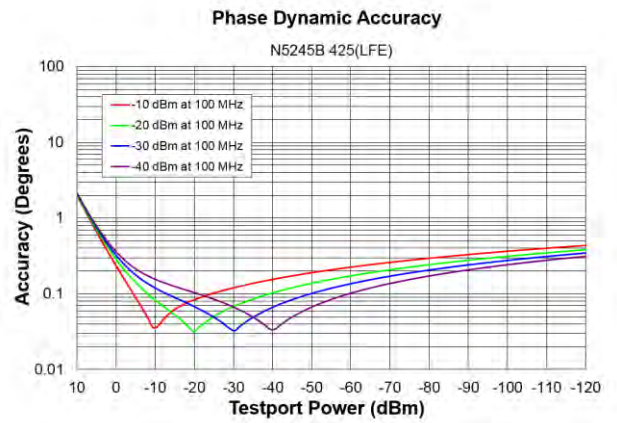
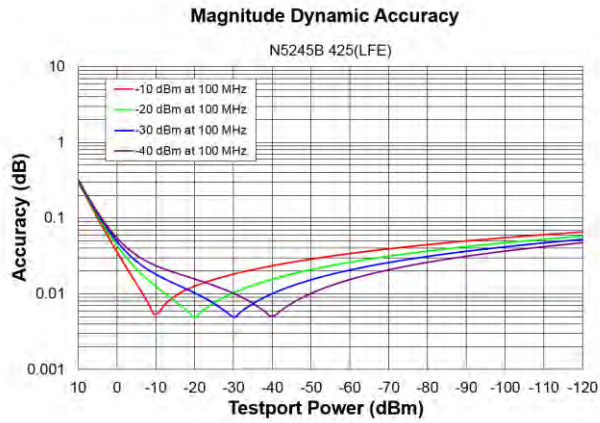

Dynamic Accuracy, 0.010 GHz

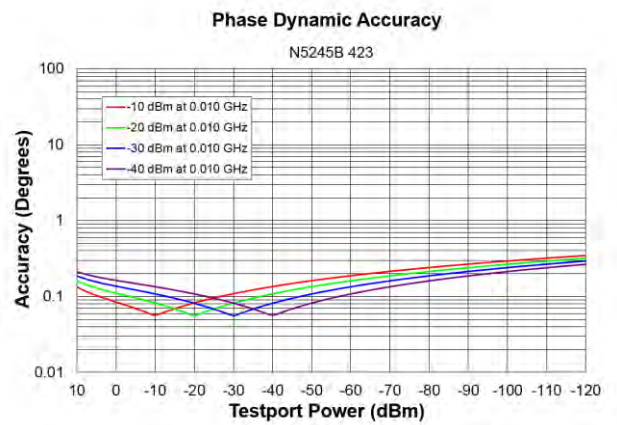
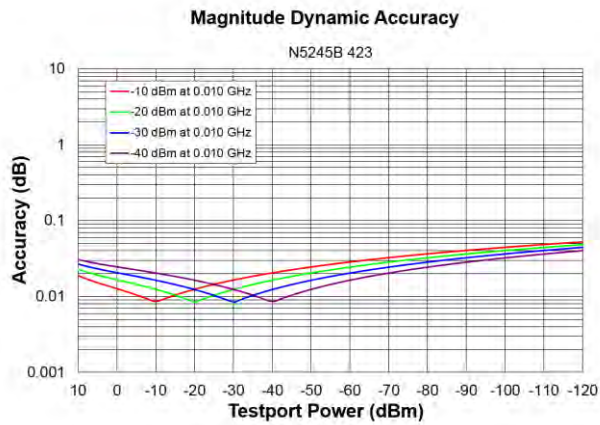

Dynamic Accuracy, 0.050 GHz

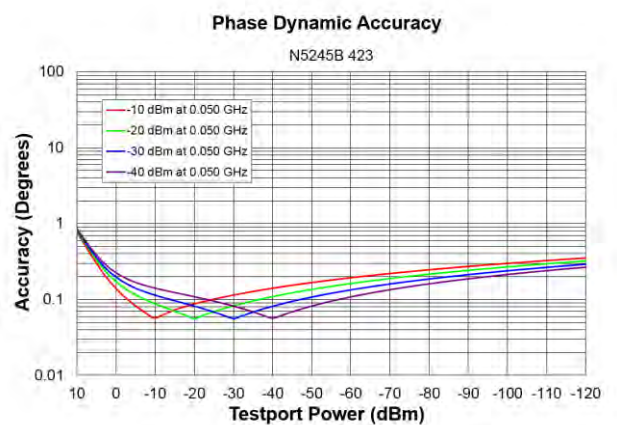
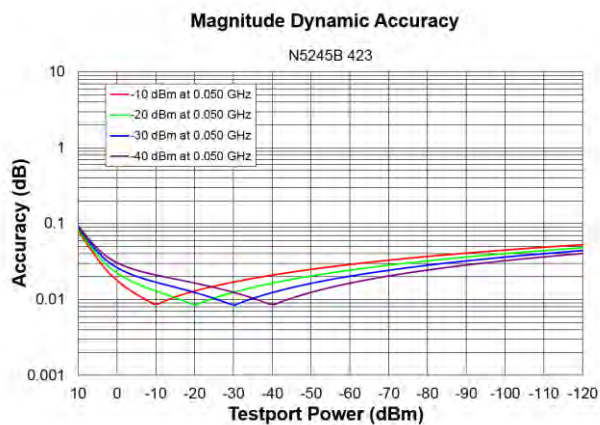

Dynamic Accuracy, 0.500 GHz

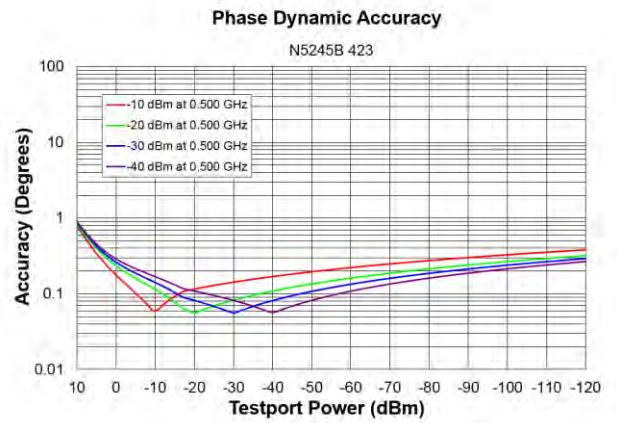
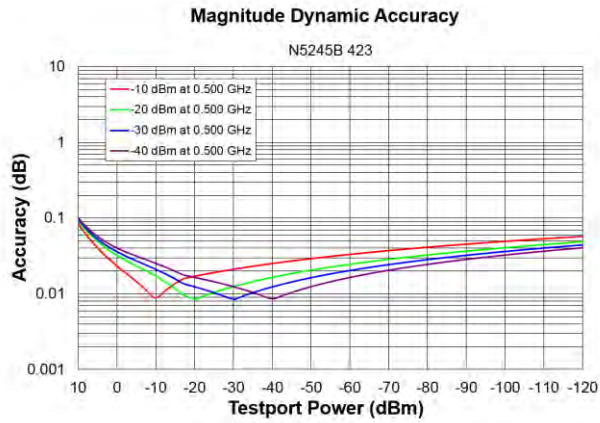

Dynamic Accuracy, 1 GHz

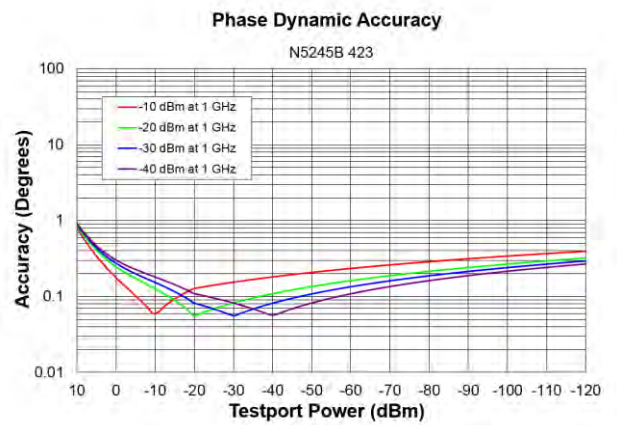
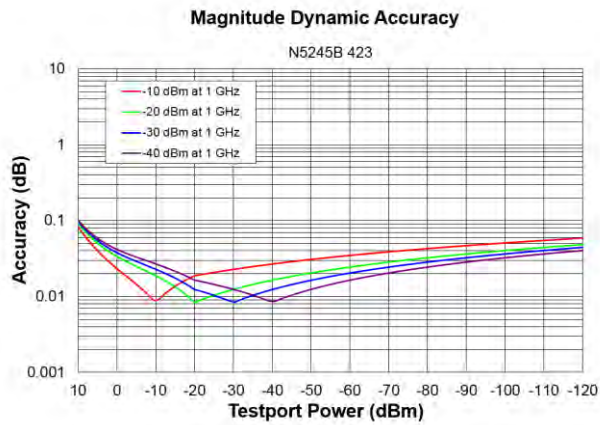

Dynamic Accuracy, 2 GHz

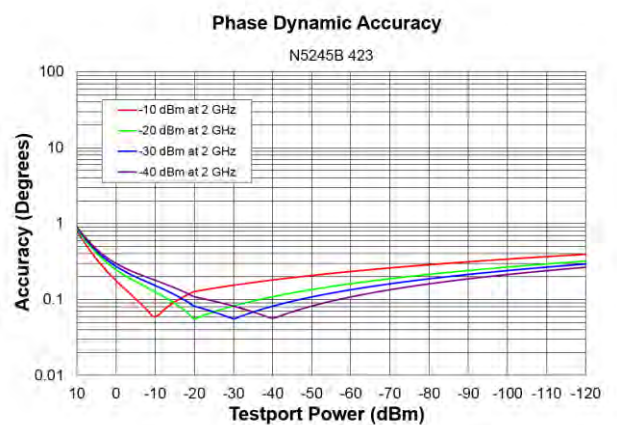
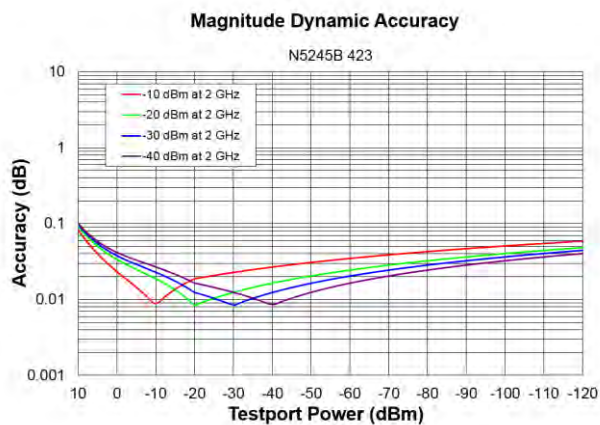

Dynamic Accuracy, 10 GHz

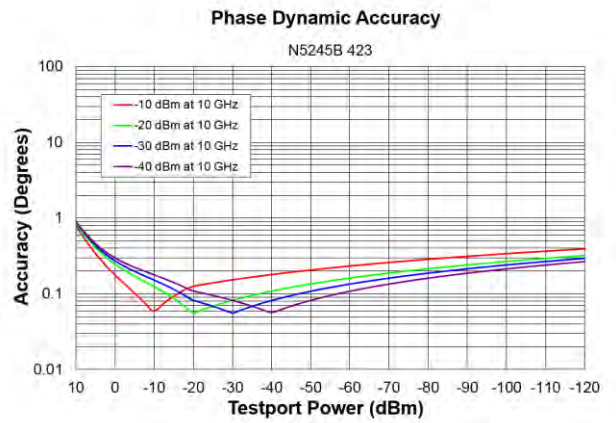
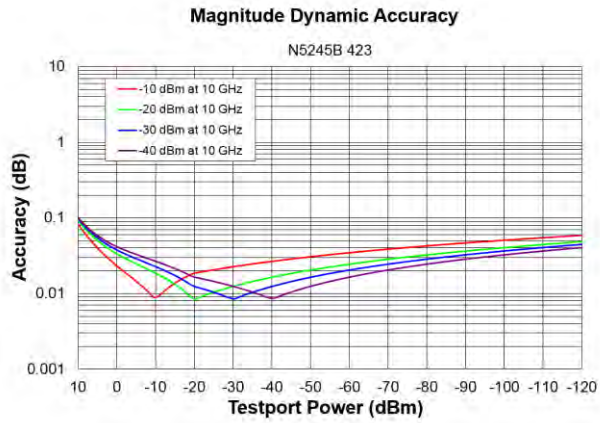

Dynamic Accuracy, 20 GHz

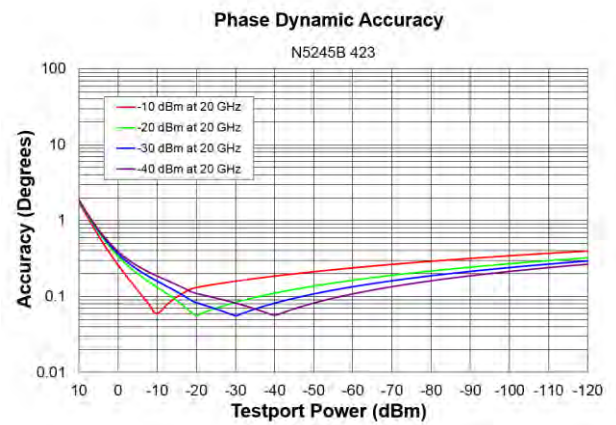
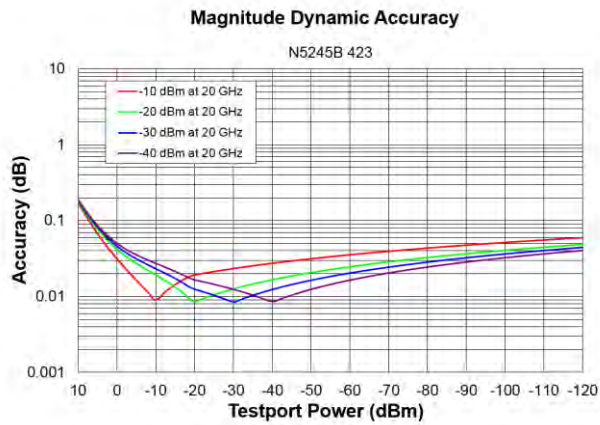

Dynamic Accuracy, 30 GHz

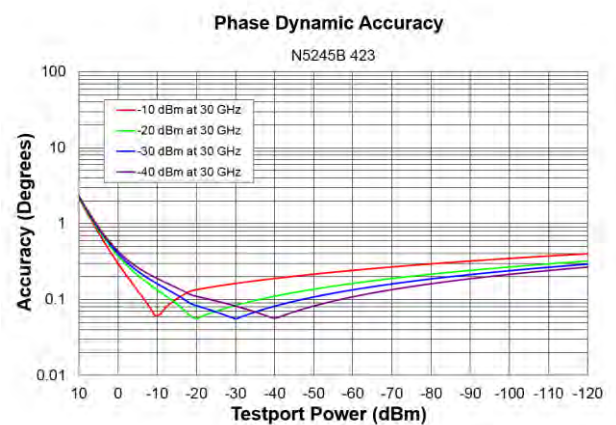
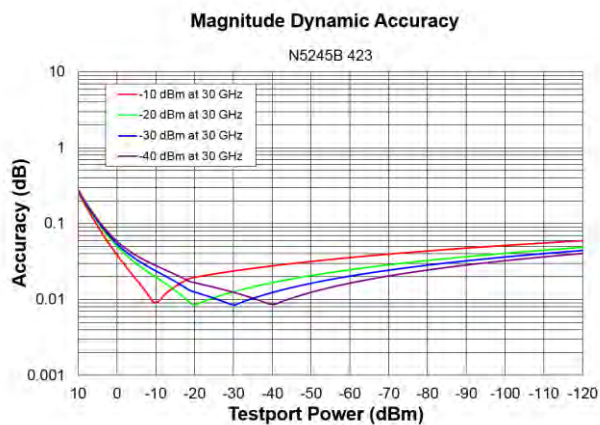

Dynamic Accuracy, 43.5 GHz

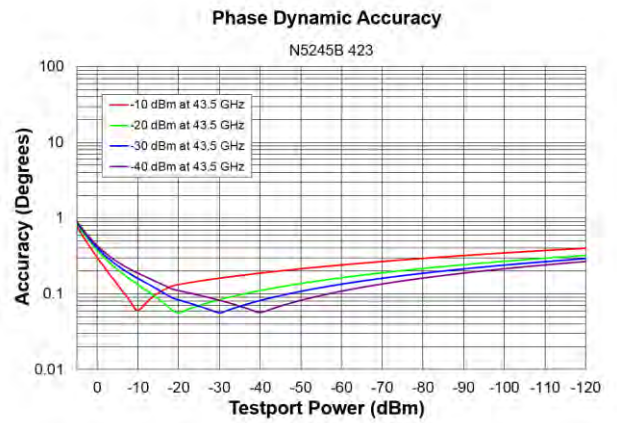
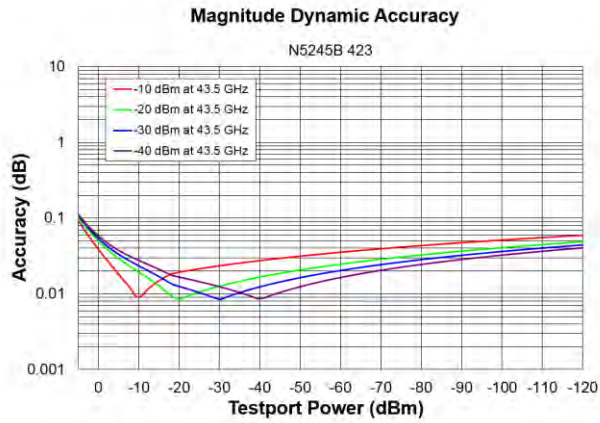

Dynamic Accuracy, 50 GHz

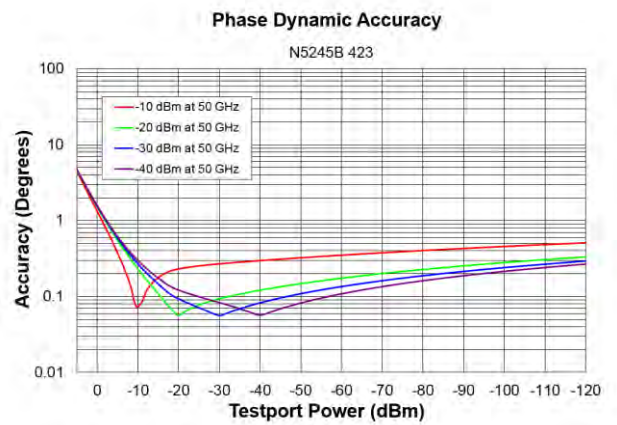
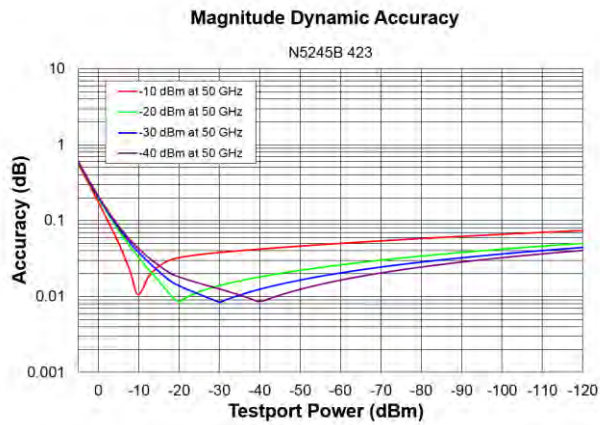

Table 30. Test Port Input (Group Delay)¹

Description	Typical Performance
Aperture (selectable)	(frequency span)/(number of points -1)
Maximum Aperture	20% of frequency span
Range	0.5 x (1/minimum aperture)
Maximum Delay	Limited to measuring no more than 180° of phase change within the minimum aperture.)
Accuracy	See graph below. Char.

The following graph shows characteristic group delay accuracy with full 2-port calibration and a 10 Hz IF bandwidth. Insertion loss is assumed to be < 2 dB and electrical length to be ten meters.

For any S_{ij} Group Delay measurement, S_{ii} = 0, S_{ij} = 1, S_{ji} = 0, S_{kl} = 0 for all kl ≠ ij

Group Delay Accuracy (Typical)

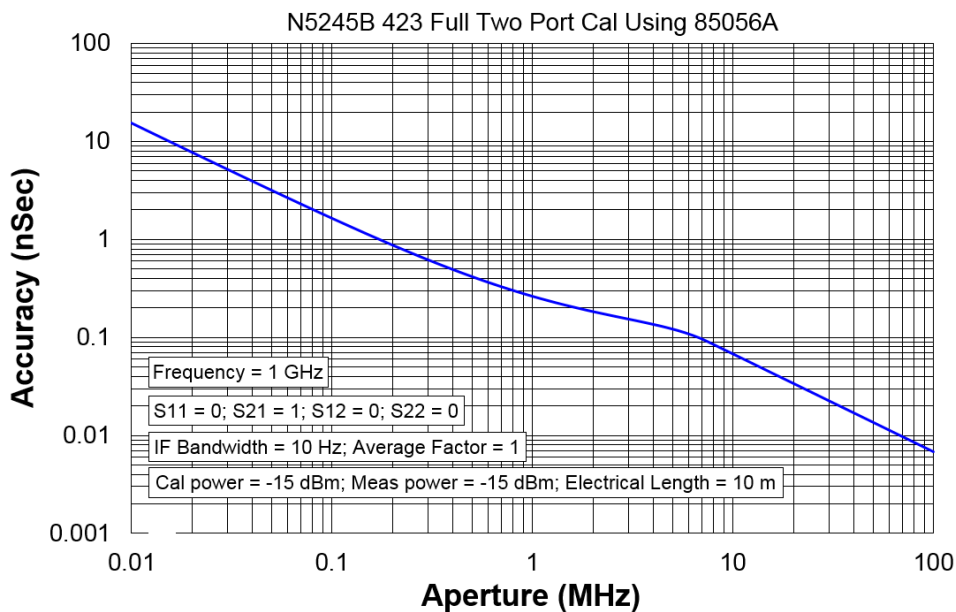

In general, the following formula can be used to determine the accuracy, in seconds, of specific group delay measurement:
 $\pm \text{Phase Accuracy (deg)} / [360 \times \text{Aperture (Hz)}]$

Depending on the aperture and device length, the phase accuracy used is either incremental phase accuracy or worst-case phase accuracy.

¹ Group delay is computed by measuring the phase change within a specified frequency step (determined by the frequency span and the number of points per sweep).

General Information

- Miscellaneous Information
- Front Panel
- Rear Panel
- Environment and Dimensions

Table 31. Miscellaneous Information

Description	Supplemental Information
System IF Bandwidth Range	1 Hz to 15 MHz, nominal (7 MHz, 10 MHz, and 15 MHz IFBW are available ONLY with FW A.09.42 and later, and with DSP version 5)
CPU	For the latest information on CPUs and associated hard drives, visit: http://na.support.keysight.com/pna/hdnumbers.html
LXI	Class C

Table 32. Front Panel Information, All Options

Description	Typical Performance
RF Connectors	
Test Ports	2.4 mm (male), 50 ohm (nominal), 0.002 in. Center Pin Recession (characteristic)
Jumpers	2.4 mm (female) connectors with 2.4 mm (male) jumper cables
USB 2.0 Ports - Master (4 ports)	
Standard	Compatible with USB 2.0
Connector	USB Type-A female
Display	
Size	31 cm (12.1 in) diagonal color active matrix LCD; 1280 (horizontal) X 800 (vertical) resolution
Refresh Rate	Vertical 60 Hz; Horizontal 49.31 kHz
Pixels	Any of the following would cause a display to be considered faulty: <ul style="list-style-type: none"> • A complete row or column consists of “stuck” or “dark” pixels. • More than six “stuck on” pixels (but not more than three green) or more than 0.002% of the total pixels are within the LCD specifications. • More than twelve “dark” pixels (but no more than seven of the same color) or more than 0.004% of the total pixels are within the LCD specifications. • Two or more consecutive “stuck on” pixels or three or more consecutive “dark” pixel (but no more than one set of two consecutive dark pixels). • “Stuck on” pixels or more than two “dark” pixels less than 6.5 mm apart (excluding consecutive pixels).

Table 32. (Continued) Front Panel Information, All Options

Description	Typical Performance
Display Range	
Magnitude	±2500 dB (at 500 dB/div), max
Phase	±2500° (at 500 degrees/div), max
Polar	10 pUnits, min 10,000 Units, max
Display Resolution	
Magnitude	0.001 dB/div, min
Phase	0.01°/div, min
Marker Resolution	
Magnitude	0.001 dB, min
Phase	0.01°, min
Polar	10 pUnit, min

Table 33. Rear Panel Information, All Options

Description	Typical Performance
10 MHz Reference In	
Connector	BNC, female
Input Frequency	10 MHz ±10 ppm
Input Level	-15 dBm to +20 dBm
Input Impedance	200 Ω, nom.
10 MHz Reference Out	
Connector	BNC, female
Output Frequency	10 MHz ±1 ppm
Signal Type	Sine Wave
Output Level	+10 dBm ±4 dB into 50 Ω
Output Impedance	50 Ω, nominal
Harmonics	<-40 dBc, typical

Table 33. (Continued) Rear Panel Information, All Options

Description	Typical Performance			
External IF Inputs				
Function	Allows use of external IF signals from remote mixers, bypassing the PNA's first converters			
Connectors	SMA (female); A, B, C, D, R (4-port); A, B, R1, R2 (2-port)			
Frequency				
Path	DSP Version	IF Bandwidth	RF Frequency	IF Frequency
Normal IF path:	4	All	< 53 MHz	2.535211 MHz
		All	>= 53 MHz	7.605634 MHz
	5	≤ 600 kHz	< 53 MHz	2.479339 MHz
			>= 53 MHz	7.438017 MHz
		1 MHz	All	7.692 MHz
		1.5 MHz	All	7.368 MHz
		2 MHz	All	8.450 MHz
		3 MHz	All	8.163 MHz
		5 MHz	All	6.897 MHz
		7 MHz	All	10.53 MHz
10 MHz	All	15.38 MHz		
		15 MHz	All	22.22 MHz
Narrowband IF path:	4 or 5	All	All	10.70 MHz
Input Impedance	50 Ω			
RF Damage Level	+23 dBm			
DC Damage Level	5.5 VDC			
0.1 dB Compression Point				
Normal IF path	-9.0 dBm at 7.438 MHz			
Narrowband IF path	-17 dBm at 10.70 MHz			
Pulse Inputs (IF Gates)				
Function	Internal receiver gates used for point-in-pulse and pulse-profile measurements			
Connectors	15-pin mini D-sub			
Input Impedance	1 K Ohm			
Source Modulators	20 ns minimum pulse width			
Receiver Gates	20 ns minimum pulse width			
DC Damage Level	5.5 VDC			
Drive Voltage	0 V (off), +3.3 V (on), nominal			

Table 33. (Continued) Rear Panel Information, All Options

Description	Typical Performance	
RF Pulse Modulator Input (Source Modulator)		
On/Off Ratio		
10 MHz to 3.2 GHz	-64 dB	
3.2 GHz to 50 GHz	-80 dB	
Pulse Period		
Minimum	20 ns	
Maximum	70 s	
Pulse Outputs		
Voltage (TTL)	High: 3.3V to 3.5V Low: <1V	
Impedance	50 Ohm	
External Test Set Driver		
Function	Used for driving remote mixers	
Connections	3.5 mm (female)	
RF Output Frequency Range	3.2 GHz to 19 GHz	
LO Output Frequency Range	1.76 GHz to 26.5 GHz	
Rear Panel LO Power¹	Upper Limit, Typical (dBm)	Lower Limit, Typical (dBm)
1.7 GHz to 6.78 GHz	5	-3
6.78 GHz to 15.4 GHz	0	-6
15.4 GHz to 26.5 GHz	4	-5
Rear Panel RF Power	Upper Limit, Typical (dBm)	Lower Limit, Typical (dBm)
3.2 GHz to 19 GHz	-3	-8

¹ LO output available in full analyzer's frequency range. The power is tested only from 3.2 GHz to 26.5 GHz.

Table 33. (Continued) Rear Panel Information, All Options

Description	Typical Performance
Devices Supported	Resolutions
Flat Panel (TFT)	1024 X 768, 800 X 600, 640 X 480
Flat Panel (DSTN)	800 X 600, 640 X 480
CRT Monitor	1280 X 1024, 1024 X 768, 800 X 600, 640 X 480
Simultaneous operation of the internal and external displays is allowed, but with 640 X 480 resolution only. If you change resolution, you can only view the external display (internal display will "white out").	
Bias Tee Inputs	
Connectors	BNC(f) for ports 1, 2, 3 and 4
Fuse	500 mA, bi-pin style
Maximum Bias Current	±200 mA with no degradation of RF specifications
Maximum Bias Voltage	±40 VDC
Trigger Inputs/Outputs	BNC(f), TTL/CMOS compatible
Test Set IO	25-pin D-Sub connector, available for external test set control
Power IO	9-pin D-Sub, female; analog and digital IO
Handler IO	36-pin parallel I/O port; all input/output signals are default set to negative logic; can be reset to positive logic via GPIB command
Pulse I/O	15-pin D connector provides access to Pulse Modulators and Generators
GPIB	Two ports - dedicated controller and dedicated talker/listener. 24-pin D-sub (Type D-24), female; compatible with IEEE-488
PCIe	Cabled PCIe x4 connector is a 4-lane slot (not currently used)
USB Ports	Two SuperSpeed USB ports (900 mA each), one USB port below LAN connector, and one USB device port. There are also four USB ports (500 mA each) on the front panel. The total current limit for all rear panel USB ports is 2.3 amps. The total current limit for all front panel USB ports is 2 amps.
LAN	10/100/1000 BaseT Ethernet, 8-pin configuration; auto selects between the data rates
VGA Video Output	15-pin mini D-Sub; Drives VGA compatible monitors
Mini DisplayPort	Miniature DisplayPort connector for connection to external displays
Line Power	
Frequency, Voltage	50/60/400 Hz for 100 to 120 VAC 50/60 Hz for 220 to 240 VAC
	Power supply is auto switching
Max	450 watts

Table 34. Analyzer Dimensions and Weight

All models are shipped with bottom feet, handles and front and rear hardware.

See detailed PNA dimension drawings at: <http://na.support.keysight.com/pna/PNADimensions.pdf>

Cabinet Dimensions	Metric (mm)	Imperial (inches)
Height		
Without bottom feet:EIA RU1 = 6	266.1	10.5
With bottom feet	279.1	11.0
Width		
Without handles or rack-mount flanges	425.6	16.8
With handles, without rack-mount flanges	458.7	18.1
With handles and rack-mount flanges	482.9	19.0
Depth		
Without front and rear panel hardware	582.3	22.9
With front and rear panel hardware, handles	649.6	25.6
Weight (nominal)	Net	Shipping
2-port models (Option 22x with 029)	46.3 kg (102 lb)	62.1 kg (137 lb)
4-port models (Option 42x with 029)	49.0 kg (108 lb)	65.3 kg (144 lb)

¹ Electronics Industry Association rack units. 1 RU = 1.75 in.

Regulatory and Environmental Information

For Regulatory and Environmental information, refer to the PNA Series Installation and Quick Start Guide, located online at <http://literature.cdn.keysight.com/litweb/pdf/E8356-90001.pdf>.

Measurement Throughput Summary

- Typical Cycle Time for Measurement Completion
- Cycle Time vs. IF Bandwidth
- Cycle Time vs. Number of Points
- Data Transfer Time

Cycle time Includes sweep time, retrace time and band-crossing time. Analyzer display turned off with DISPLAY:ENABLE OFF. Add 21 ms for display on. Data for one trace (S₁₁) measurement.

Table 35a. Cycle Time (ms) for Measurement Completion, All Models, All Options - Typical

Sweep Range	IF Bandwidth		Number of Points				
			201	401	1601	16001	32001
9 GHz to 10 GHz	600 kHz	Uncorrected	5.5	5.5	9.4	59.4	116
		2-Port cal	18.0	19.0	26.0	132	250
	10 kHz	Uncorrected	28.1	53.1	203	1995	3988
		2-Port cal	65.6	116	414	4003	7991
	1 kHz	Uncorrected	227	445	1744	17028	33828
		2-Port cal	461	898	3150	30669	67680
10 GHz to 20 GHz	600 kHz	Uncorrected	17.2	18.8	23.4	68.8	120
		2-Port cal	43.8	46.9	56.3	155	259
	10 kHz	Uncorrected	67.2	127	259	2003	3995
		2-Port cal	144	261	523	4016	8003
	1 kHz	Uncorrected	233	456	1781	17375	34516
		2-Port cal	475	922	3570	34758	69055

Table 35b. N5244B Cycle Time (ms) for Full-Span Measurement Completion - Typical

10 MHz to 43.5 GHz		Number of Points				
IF Bandwidth		201	401	1601	16001	32001
600 kHz	Uncorrected	48.4	59.4	78.1	156	206
	2-Port cal	105	127	164	317	428
10 kHz	Uncorrected	84.4	147	505	2172	4188
	2-Port cal	175	302	1016	4350	8384
1 kHz	Uncorrected	250	477	1822	17617	34984
	2-Port cal	505	959	3647	35250	69992

Table 35c. N5245B Cycle Time (ms) for Full-Span Measurement Completion - Typical

10 MHz to 50 GHz		Number of Points				
IF Bandwidth		201	401	1601	16001	32001
600 kHz	Uncorrected	55.5	67.2	85.9	166	223
	2-Port cal	116	141	175	334	443
10 kHz	Uncorrected	87.5	151	512	2182	4203
	2-Port cal	180	307	1027	4364	8422
1 kHz	Uncorrected	252	480	1825	17648	35031
	2-Port cal	509	966	3656	35305	70086

Table 36. Cycle Time vs. IF Bandwidth - Typical

Applies to the Preset condition (201 points, correction off) except for the following changes:

- CF = 10 GHz
- Span = 100 MHz
- Display off (add 21 ms for display on)

Cycle time includes sweep and retrace time.

Description		N5244B/45B
IF Bandwidth (Hz)	Cycle Time (ms)	Trace Noise Magnitude (dB rms)
600,000	5.5	0.005
100,000	5.5	0.0024
30,000	8.6	0.0017
10,000	28.9	0.0014
3,000	70.3	0.001
1,000	223	0.0008
300	642	0.0006
100	1823	0.0005
30	5977	0.0005
10	17836	0.0005
3	59289	0.0004

Table 37. Cycle Time (ms) vs. Number of Points - Typical

Applies to the Preset condition (correction off) except for the following changes:

- CF = 10 GHz
- Span = 100 MHz
- Display off (add 21 ms for display on)

Cycle time includes sweep and retrace time.

Description	IF Bandwidth (Hz)			
	1,000	10,000	30,000	600,000
3	6.3	4.7	4.7	4.7
11	15.6	5.5	4.7	4.7
51	59.4	10.2	4.7	4.7
101	113	15.6	6.3	4.7
201	222	28.1	8.6	4.7
401	436	53.1	14.1	5.5
801	859	103	23.4	6.3
1,601	1706	203	43.8	9.4
6,401	6719	800	166	26.6
16,001	16656	1995	408	60.2
32,001	33086	3988	812	116

Table 38. Data Transfer Time¹ (ms) - Typical

Description	Number of Points				
	201	401	1601	16,001	32,001
SCPI over GPIB (Program executed on external PC ²)					
32-bit floating point	4.6	9.3	38	352	720
64-bit floating point	9.4	18.8	73.4	730	1455
ASCII	36.7	72.5	288	2882	5762
SCPI over SICL/LAN or TCP/IP Socket³ (Program executed in the analyzer)					
32-bit floating point	<1	<1	<1	1.2	2.4
64-bit floating point	<1	<1	<1	2.3	4.6
ASCII	2.1	4	15	148	295
COM¹ (Program executed in the analyzer)					
32-bit floating point	<1	<1	<1	<1	<1
Variant type	<1	<1	1.4	12.4	25.5
DCOM over LAN³ (Program executed on external PC)					
32-bit floating point	<1	<1	<1	2.3	4.4
Variant type	<1	1.6	5.3	52	105.5

¹ Measured with the analyzer display off. Values will increase slightly if the analyzer display is on.

² Measured when using the SCPI command DISPlay: VISible OFF.

³ Values are for real and imaginary pairs, with the analyzer display off, using Gigabit Ethernet.

NOTE

Specifications for Recall & Sweep Speed are not provided for the N522xB analyzers.

Front-Panel Jumpers

NOTE

All PNA-X options have the following front-panel jumpers for each port.



- Measurement Receiver Inputs
- Reference Receiver Inputs and Reference Source Outputs
- Source Outputs
- Coupler Inputs
- Damage Level

Table 39. Measurement Receiver Inputs (dBm) - Typical

(RCVR A, B, C, D IN) @ 0.1dB Typical Compression

Description	All Options
10 MHz to 1 GHz	-3
1 GHz to 2 GHz	-2
2 GHz to 10 GHz	-2
10 GHz to 16 GHz	-4
16 GHz to 26.5 GHz	-4
26.5 GHz to 43.5 GHz	-5
43.5 GHz to 50 GHz	-6

Table 40a. Reference Receiver Inputs and Reference Source Outputs (dBm) - Typical

(RCVR R1 IN, REF 1 SOURCE OUT) @ Max Specified Output Power

Description	Option 201, 401		Option 21x, 41x		Option 22x, 42x	
	Filtered Mode ¹	Hi Power Mode ¹	Filtered Mode ¹	Hi Power Mode ¹	Filtered Mode ¹	Hi Power Mode ¹
10 MHz to 50 MHz	-33	-25	-32	-27	-32	-25
50 MHz to 500 MHz	-21	-16	-19	-14	-19	-14
500 MHz to 1 GHz	-9	-4	-7	-2	-7	-2
1 GHz to 2 GHz	-9	-4	-7	-3	-7	-2
2 GHz to 3.2 GHz	-8	-6	-6	-4	-7	-5
3.2 GHz to 10 GHz	-3	-3	0	0	-3	-3
10 GHz to 16 GHz	-3	-3	-1	-1	-3	-3
16 GHz to 26.5 GHz	-3	-3	-1	-1	-4	-4
26.5 GHz to 30 GHz	-3	-3	0	0	-3	-3
30 GHz to 32 GHz	-4	-4	-2	-2	-5	-5
32 GHz to 35 GHz	-2	-2	0	0	-2	-2
35 GHz to 43.5 GHz	-3	-3	-1	-1	-5	-5
43.5 GHz to 47 GHz	-6	-6	-5	-5	-23	-23
47 GHz to 50 GHz	-19	-19	-17	-17	-22	-22

¹ In Filtered Mode, the signal path goes through filters to minimize harmonics below 3.2 GHz. In Hi Power Mode, the signal bypasses the filters to maximize output power.

Table 40b. Reference Receiver Inputs and Reference Source Outputs (dBm) – Typical

(RCVR R2, R3, R4 IN, REF 2, 3, 4 SOURCE OUT) @ Max Specified Output Power

Description	Option 401		Options 201, 401	Option 41x		Options 21x, 41x
	RCVR R3 IN, REF 3 SOURCE OUT	RCVR R3 IN, REF 3 SOURCE OUT	RCVR R2, R4 IN, REF 2, 4 SOURCE OUT	RCVR R3 IN, REF 3 SOURCE OUT	RCVR R3 IN, REF 3 SOURCE OUT	RCVR R2, R4 IN, REF 2, 4 SOURCE OUT
	Filtered Mode ¹	Hi Power Mode ¹		Filtered Mode ¹	Hi Power Mode ¹	
10 MHz to 50 MHz	-31	-23	-27	-31	-26	-25
50 MHz to 500 MHz	-19	-14	-14	-18	-13	-14
500 MHz to 1 GHz	-7	-2	-2	-6	-1	-2
1 GHz to 2 GHz	-7	-2	-2	-6	-2	-2
2 GHz to 3.2 GHz	-7	-5	-2	-4	-2	-2
3.2 GHz to 10 GHz	-1	-1	-1	1	1	-1
10 GHz to 16 GHz	-1	-1	-1	0	0	-2
16 GHz to 26.5 GHz	-1	-1	-1	1	1	-2
26.5 GHz to 30 GHz	0	0	-1	2	2	-3
30 GHz to 32 GHz	-1	-1	-2	0	0	-5
32 GHz to 35 GHz	0	0	-1	2	2	-3
35 GHz to 43.5 GHz	-2	-2	-2	0	0	-5
43.5 GHz to 47 GHz	-5	-5	-5	-4	-4	-9
47 GHz to 50 GHz	-17	-17	-17	-16	-16	-21

¹ In Filtered Mode, the signal path goes through filters to minimize harmonics below 3.2 GHz. In Hi Power Mode, the signal bypasses the filters to maximize output power.

Table 40c. Reference Receiver Inputs and Reference Source Outputs (dBm) - Typical

(RCVR R2, R3, R4 IN, REF 2, 3, 4 SOURCE OUT) @ Max Specified Output Power

Description	Options 42x		Options 22x, 42x
	RCVR R3 IN, REF 3 SOURCE OUT	RCVR R3 IN, REF 3 SOURCE OUT	RCVR R2, R4 IN, REF 2, 4 SOURCE OUT
	Filtered Mode ¹	Hi Power Mode ¹	
10 MHz to 50 MHz	-31	-24	-29
50 MHz to 500 MHz	-18	-13	-16
500 MHz to 2 GHz	-6	-1	-4
2 GHz to 3.2 GHz	-5	-3	-4
3.2 GHz to 10 GHz	0	0	0
10 GHz to 26.5 GHz	-2	-2	-2
26.5 GHz to 30 GHz	-1	-1	-2
30 GHz to 32 GHz	-3	-3	-4
32 GHz to 35 GHz	0	0	-2
35 GHz to 43.5 GHz	-3	-3	-4
43.5 GHz to 47 GHz	-22	-22	-8
47 GHz to 50 GHz	-21	-21	-21

¹ In Filtered Mode, the signal path goes through filters to minimize harmonics below 3.2 GHz. In Hi Power Mode, the signal bypasses the filters to maximize output power.

Table 41a. Source Outputs (dBm) - Typical

(PORT 1, 2, 3, 4 SOURCE OUT) @ Max Specified Output Power

Description	Options 201, 401		Options 21x, 41x			
	PORT 1, 3 SOURCE OUT		PORT 2, 4 SOURCE OUT	PORT 1, 3 SOURCE OUT		PORT 2, 4 SOURCE OUT
	Filtered Mode ¹	Hi Power Mode ¹		Filtered Mode ¹	Hi Power Mode ¹	
10 MHz to 50 MHz	4	12	12	5	10	13
50 MHz to 1 GHz	8	13	13	9	14	14
1 GHz to 2 GHz	9	14	14	9	13	14
2 GHz to 3.2 GHz	9	11	14	9	11	14
3.2 GHz to 10 GHz	14	14	14	14	14	14
10 GHz to 16 GHz	14	14	14	13	13	13
16 GHz to 26.5 GHz	14	15	15	13	13	13
26.5 GHz to 30 GHz	14	14	14	12	12	12
30 GHz to 32 GHz	13	13	13	10	10	10
32 GHz to 35 GHz	14	14	14	12	12	12
35 GHz to 43.5 GHz	11	11	11	8	8	8
43.5 GHz to 47 GHz	8	8	8	4	4	4
47 GHz to 50 GHz	-5	-5	-5	-8	-8	-8

¹ In Filtered Mode, the signal path goes through filters to minimize harmonics below 3.2 GHz. In Hi Power Mode, the signal bypasses the filters to maximize output power.

Table 41b. Source Outputs (dBm) - Typical

(PORT 1, 2, 3, 4 SOURCE OUT) @ Max Specified Output Power

Description	Options 22x, 42x, 029		
	PORT 1, 3 SOURCE OUT		PORT 2, 4 SOURCE OUT
	Filtered Mode ¹	Hi Power Mode ¹	
10 MHz to 50 MHz	5	12	11
50 MHz to 2 GHz	9	14	14
2 GHz to 3.2 GHz	9	11	14
3.2 GHz to 10 GHz	14	14	14
10 GHz to 26.5 GHz	13	13	13
26.5 GHz to 30 GHz	12	12	12
30 GHz to 32 GHz	10	10	10
32 GHz to 35 GHz	12	12	12
35 GHz to 43.5 GHz	8	8	8
43.5 GHz to 47 GHz	3	3	3
47 GHz to 50 GHz	-9	-9	-10

¹ In Filtered Mode, the signal path goes through filters to minimize harmonics below 3.2 GHz. In Hi Power Mode, the signal bypasses the filters to maximize output power.

Table 42. Coupler Inputs (dB) - Typical

(PORT 1, 2, 3, 4 CPLR THRU) Insertion Loss of Coupler Thru

Description	Options 201, 401	Options 21x, 41x, 22x, 42x	Option 029 ¹
	All Ports	All Ports	Ports 1, 2
10 MHz to 500 MHz	0.25	1	1.5
500 MHz-to 2 GHz	0.5	1	1.5
2 GHz to 10 GHz	1	1	1.5
10 GHz to 16 GHz	1	2	2.5
16 GHz to 26.5 GHz	1.5	2.5	3.0
26.5 GHz to 35 GHz	2	3	3.7
35 GHz to 43.5 GHz	2.5	4	4.7
43.5 GHz to 47 GHz	2.5	5	5.7
47 GHz to 50 GHz	3	6	7

¹ Option 029 affects only port 1 and 2 coupler thru insertion loss. Refer to Options 21x, 41x, 22x, 42x for the coupler thru insertion loss on port 3 or port 4. Port 1 impedance tuner switch is in bypass position and port 2 noise receiver switch is in normal position.

Table 43. Damage Level - Typical

Description	RF (dBm)	DC (v)
RCVR A, B, C, D IN	15	7
RCVR R1, R2, R3, R4 IN	15	7
REF 1 SOURCE OUT	15	7
REF 2, 3, 4 SOURCE OUT	27	7
PORT 1, 2, 3, 4 SOURCE OUT	27	5
PORT 1CPLR THRU	27 (10 ¹)	40
PORT 2, 3, 4 CPLR THRU	27	40
PORT 1, 2, 3, 4 CPLR ARM	30	7

¹When the source impedance tuner is switched in the path of Option 224 or 423 with Option S93029A configuration, +10 dBm input to port 1 CPLR THRU damages the tuner.

Test Set Block Diagrams

NOTE

For best readability, use a color printer for printing the following graphics.

Legend

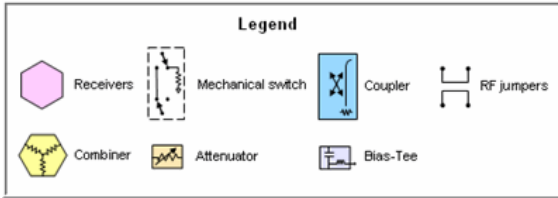

Figure 1. 2-Port N5244B and N5245B Base Unit Option 201

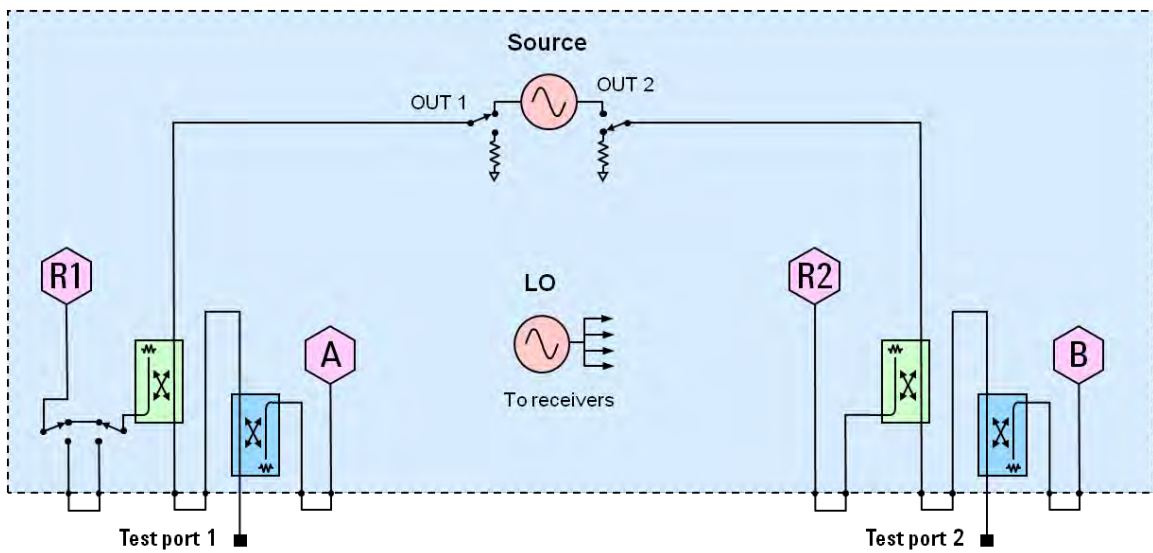

Figure 2. 2-Port N5244B and N5245B Option 217

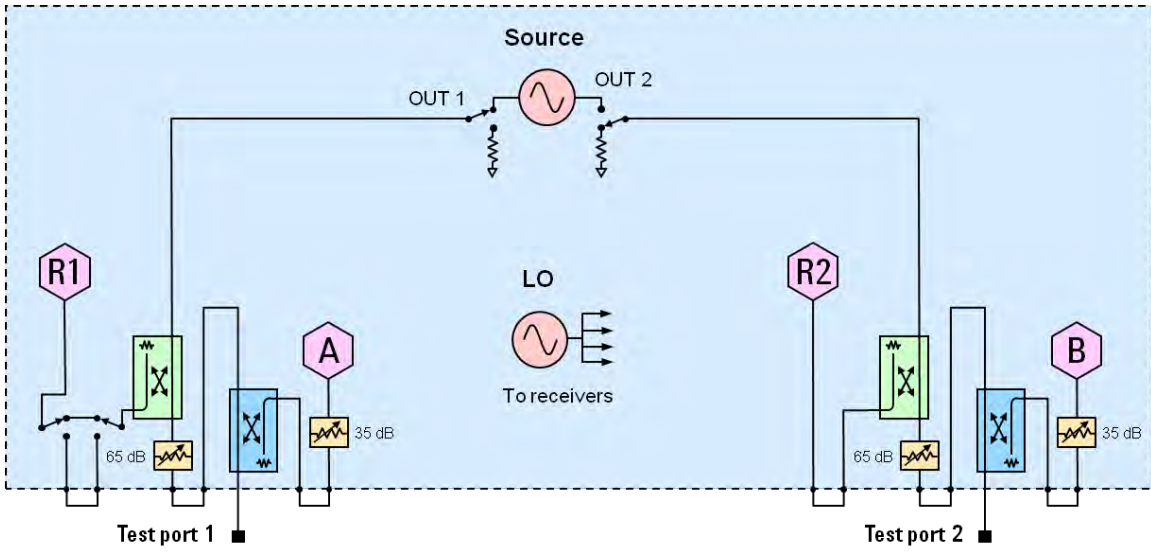

Figure 3. 2-Port N5244B and N5245B Option 219

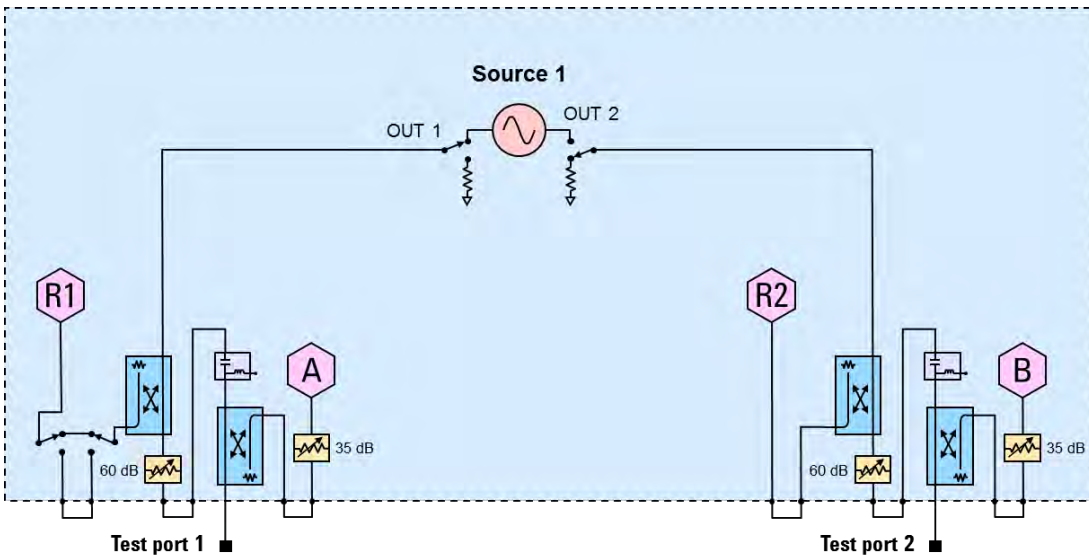

Figure 4. 2-Port N5244B and N5245B Option 222

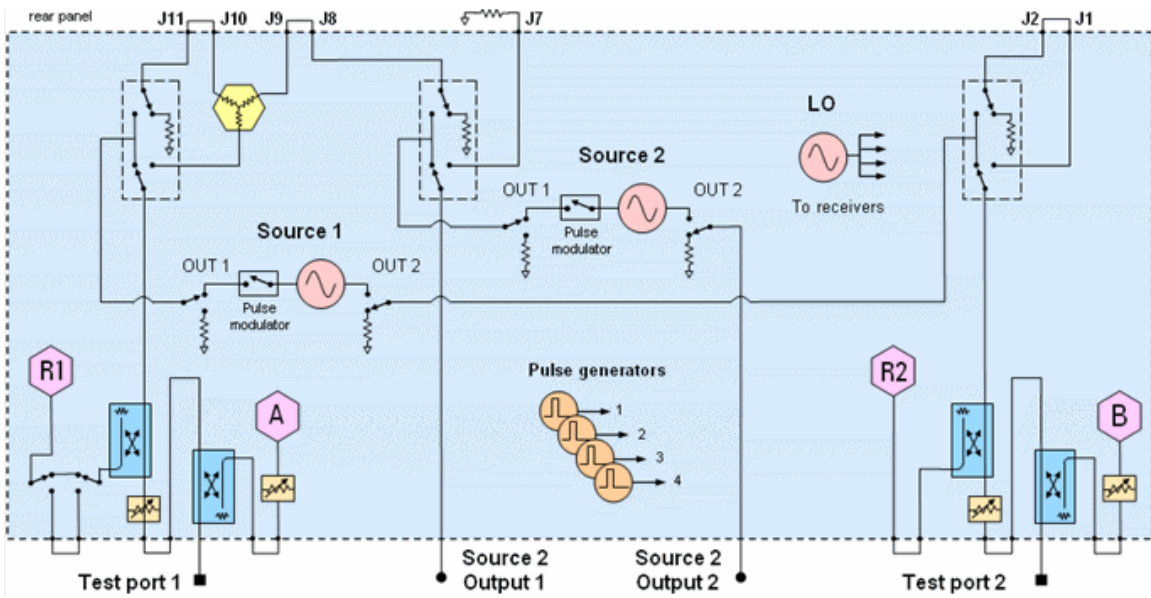

Figure 5. 2-Port N5244B and N5245B Option 224

Also shown, Option 025 adds 4 pulse generators. Option 021 and 022 adds pulse modulators.

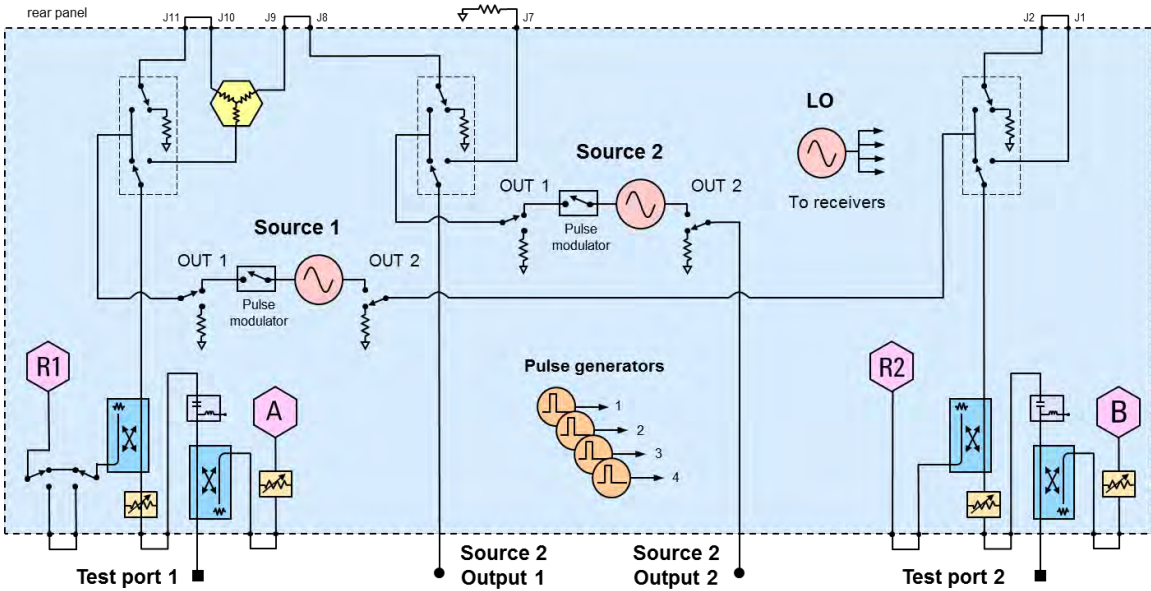

Figure 6. 2-Port N5244B and N5245B Option 224 with 029

Also shown, Option 025 adds 4 pulse generators. Option 021 and 022 adds pulse modulators.

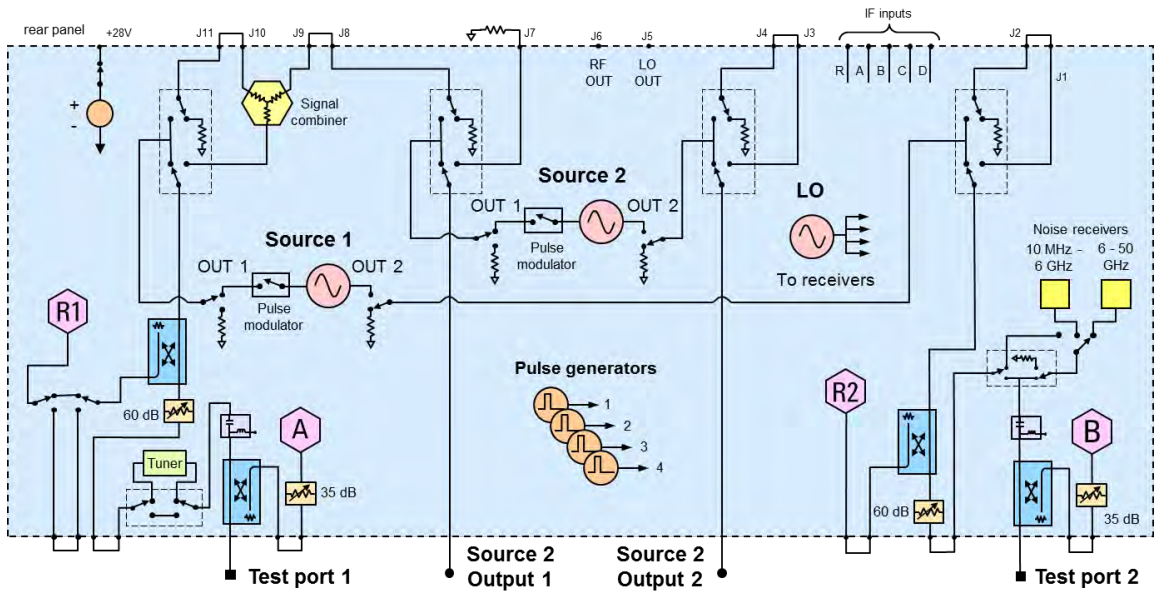

Figure 7. 4-Port N5244B and N5245B Base Unit Option 401

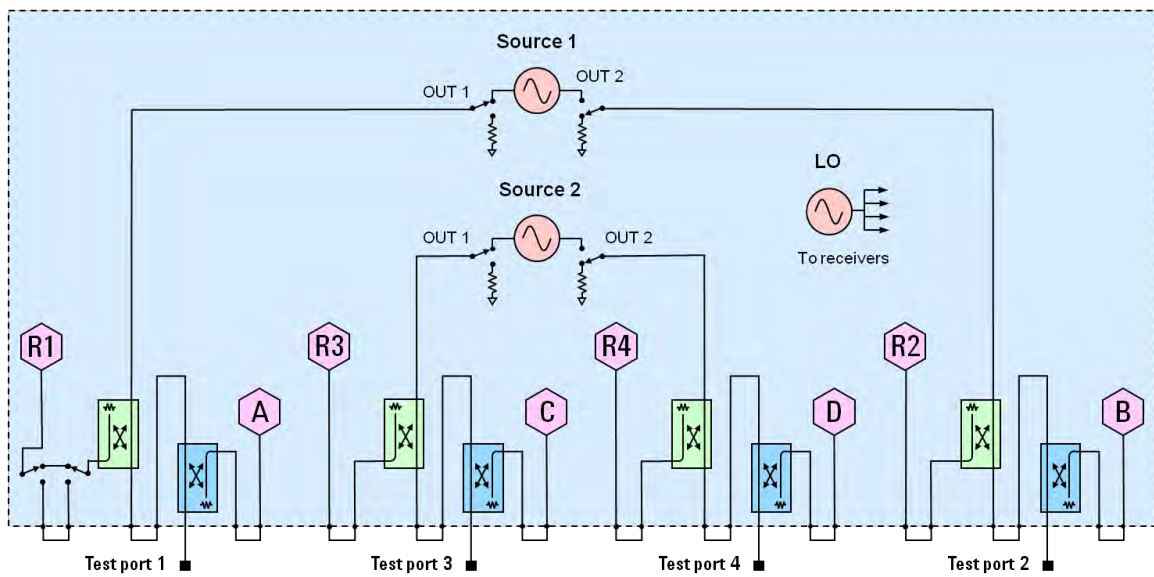

Figure 8. 4-Port N5244B and N5245B Option 417

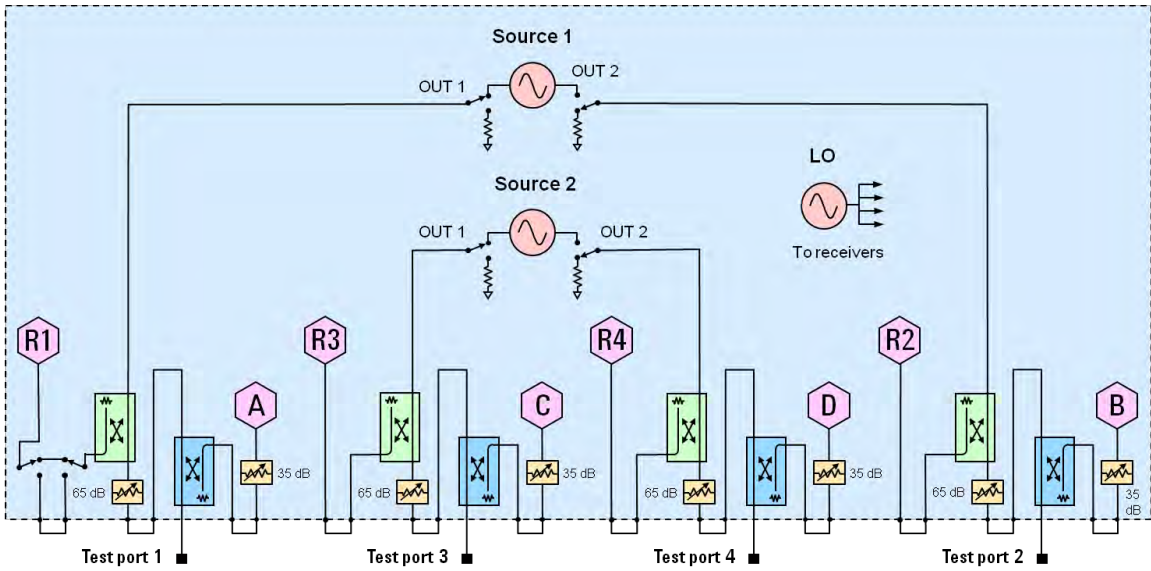

Figure 9. 4-Port N5244B and N5245B Option 419

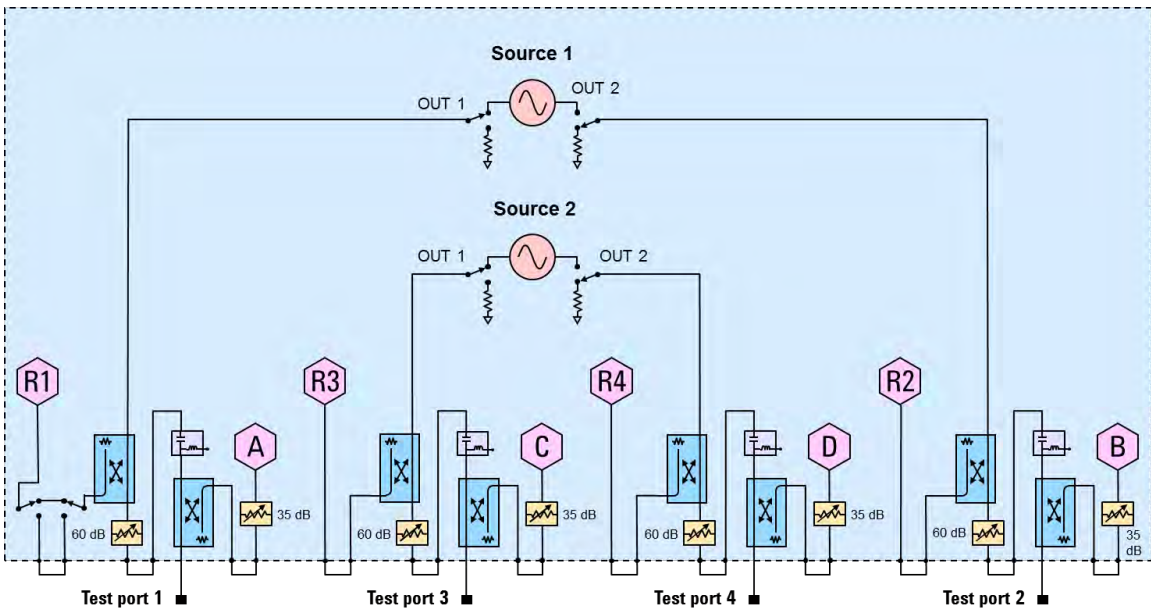

Figure 10. 4-Port N5244B and N5245B Option 422

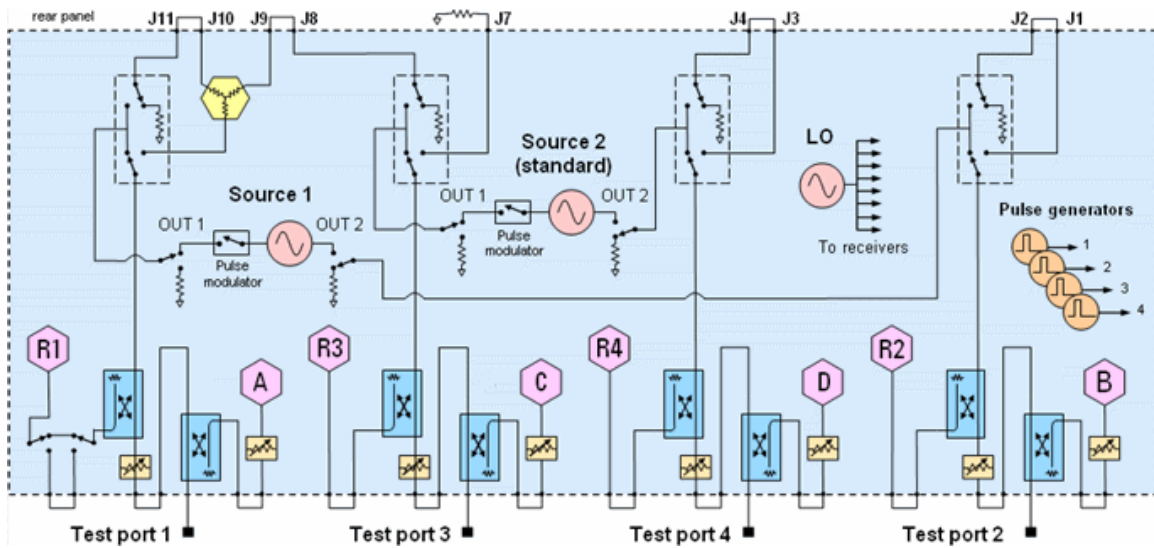

Figure 11. 4-Port N5244B and N5245B Option 423

Also shown, Option 025 adds 4 pulse generators. Option 021 and 022 adds pulse modulators.

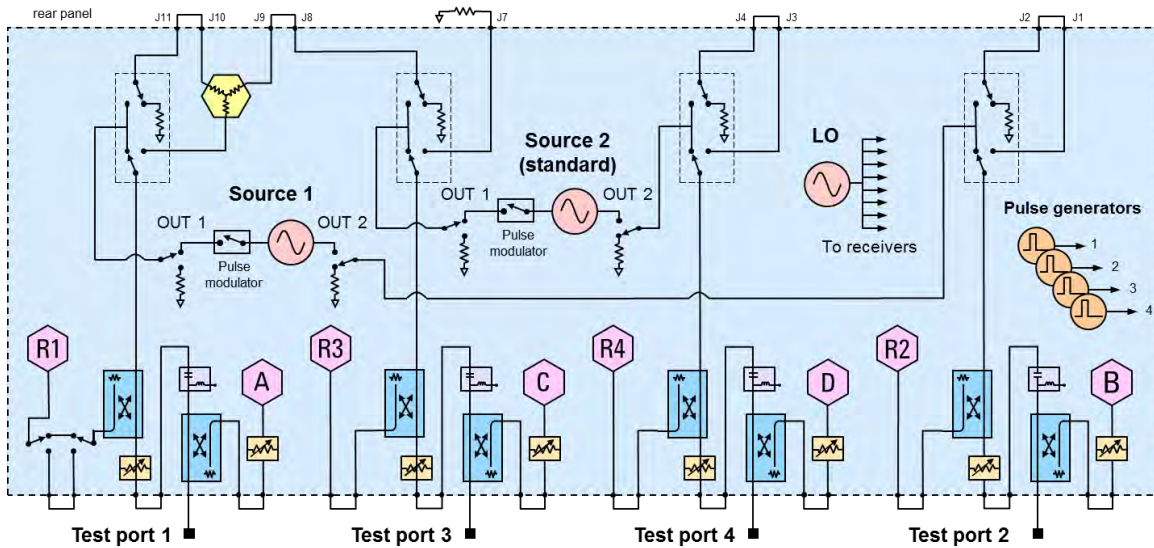

Figure 12. 4-Port N5244B and N5245B Option 423 with 029

Also shown, Option 025 adds 4 pulse generators. Option 021 and 022 adds pulse modulators.

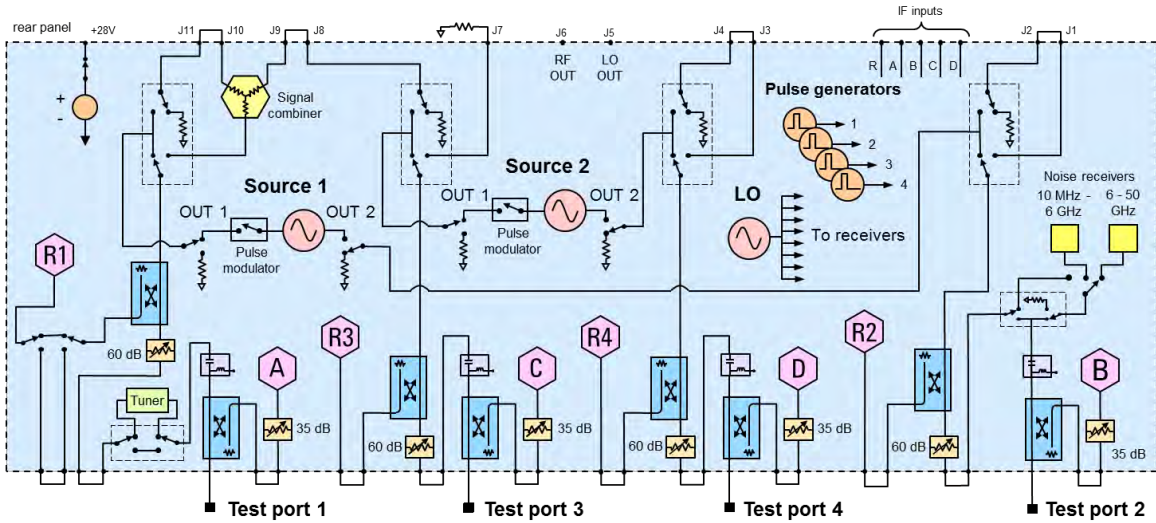

Figure 13. Option 425 Low Frequency Extension

The following LFE block diagram shows how the low-frequency hardware is configured for a single test port. The other ports are configured similarly.

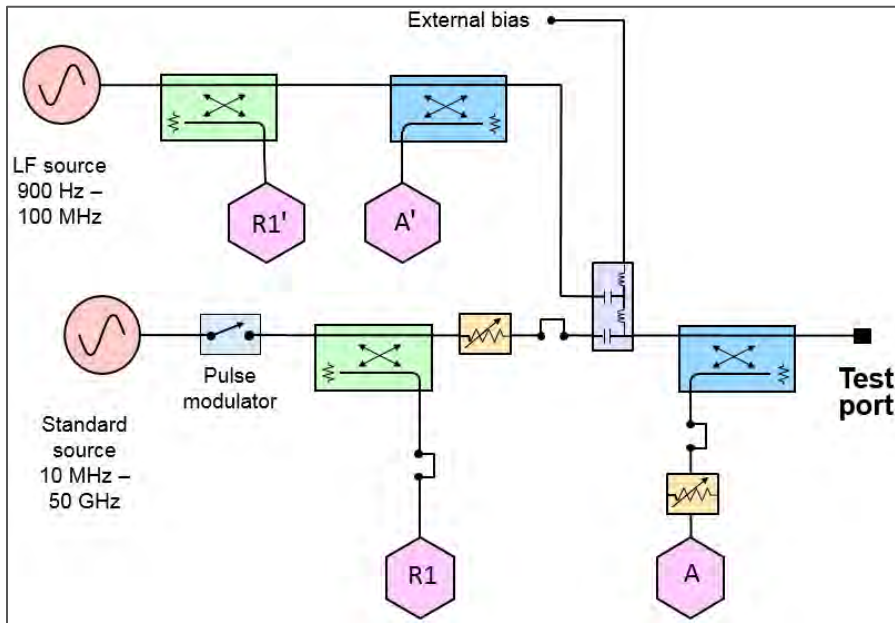
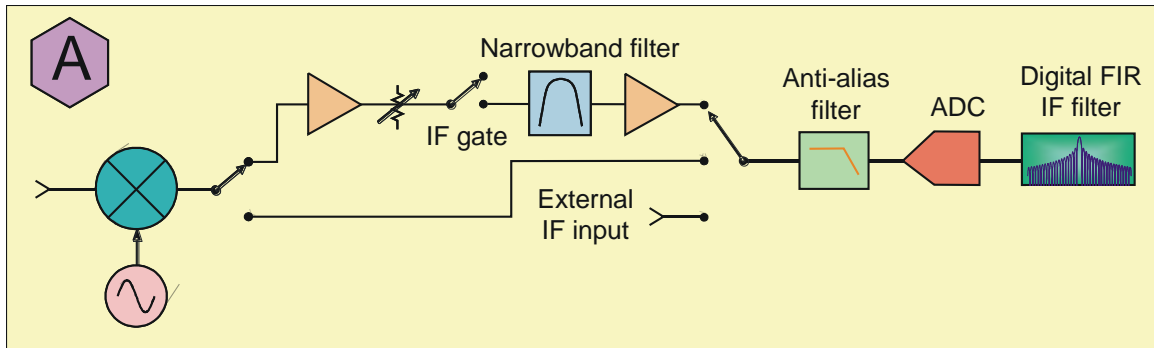

Figure 14. Receiver Block Diagram





This information is subject to change without notice.

© Keysight Technologies 2017 - 2018

Print Date: February 6, 2018



N5245-90028

www.keysight.com