

Keysight Technologies

PNA and PNA-L Series

Microwave Network Analyzers

The standard in
microwave network analysis



Table of Contents

PNA Family Sets the Standard for Microwave Network Analysis.....	03
Complete Solutions for a Wide Range of Applications	04
Innovative Features Across the PNA Family	05
Connectivity to Match Your Application.....	06
PNA Series.....	07
Choose the Right Hardware for Your Test Needs	09
Innovative Applications	10
PNA-L: Passive and Active Device Test at Affordable Prices	20
PNA-L Series Block Diagrams	21
PNA-L Series:	
The Economical Choice for Signal Integrity and Material Measurements	22
On-Wafer Measurements with the PNA Family	23
Extend the Power of the PNA Family to Multiport Devices	24
Completing the Solution	25

PNA Family Sets the Standard for Microwave Network Analysis

Choose the leader

The PNA family builds on Keysight's 45-year legacy of excellence in network analysis to deliver new standards in performance, speed, accuracy, and versatility for microwave component test. The PNA family includes:

PNA-X Series – Keysight's most advanced and flexible network analyzer, providing complete linear and nonlinear component characterization in a single instrument with a single set of connections

highest performing network analyzer, offering many advanced measurement applications

S-parameter and simple nonlinear testing of passive components, amplifiers, and frequency converters

PNA Series – the industry's

PNA-L Series – designed for



PNA-X Series Network Analyzers

N5249B	10 MHz to 8.5 GHz
N5241B	10 MHz to 13.5 GHz
N5242B	10 MHz to 26.5 GHz
N5244B	10 MHz to 43.5 GHz

PNA Series Network Analyzers

N5221B	10 MHz to 13.5 GHz
N5222B	10 MHz to 26.5 GHz*
N5224B	10 MHz to 43.5 GHz

PNA-L Series Network Analyzers

N5239B	300 kHz to 8.5 GHz
N5231B	300 kHz to 13.5 GHz
N5232B	300 kHz to 20 GHz
N5234B	10 MHz to 43.5 GHz
N5235B	10 MHz to 50 GHz

* Some configuration options allow operation down to 900 Hz

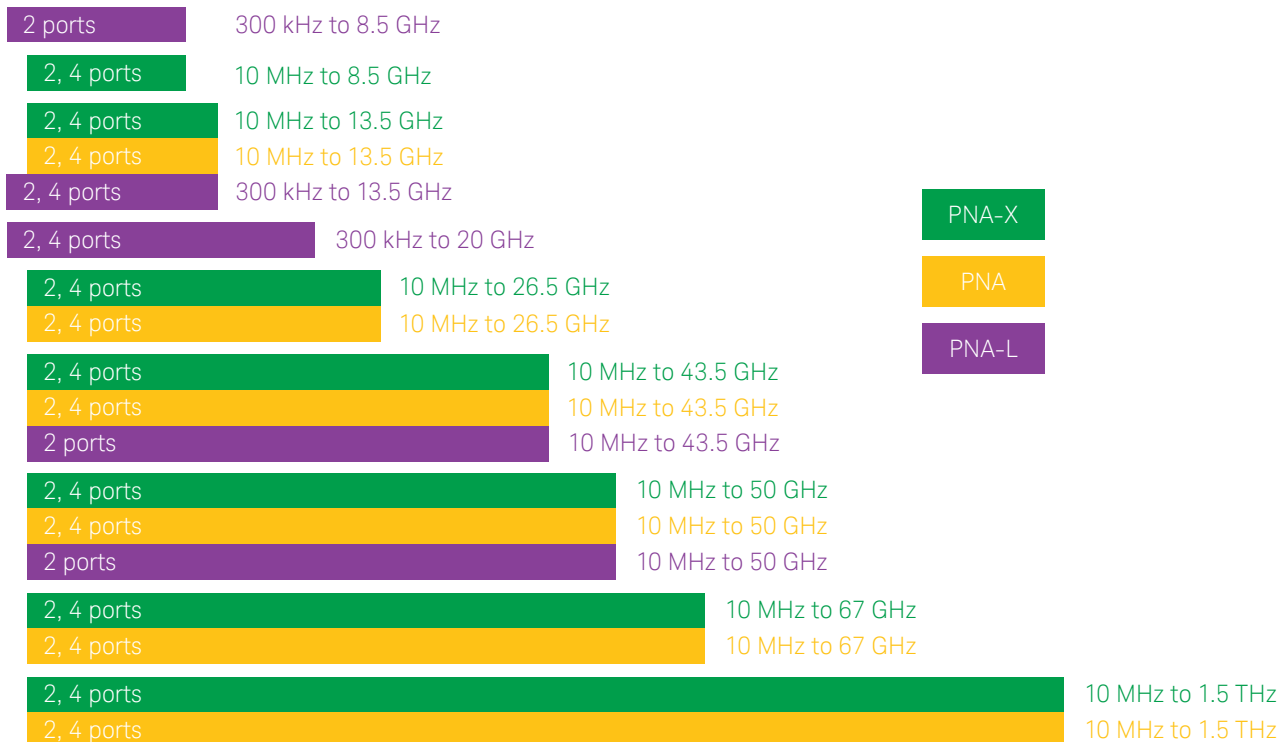

Complete Solutions for a Wide Range of Applications



In addition to being very capable standalone network analyzers, PNA and PNA-L instruments often form the core of more advanced measurement systems to serve a variety of microwave measurement applications.

Future-proof your microwave component testing

All members of the PNA family share a common software platform that makes it easy to choose just the right level of performance to match your budget and measurement needs. This commonality guarantees measurement consistency and repeatability and a common remote-programming interface across multiple instruments in R&D and manufacturing. All of the powerful PNA software applications can be added later to meet future test requirements.

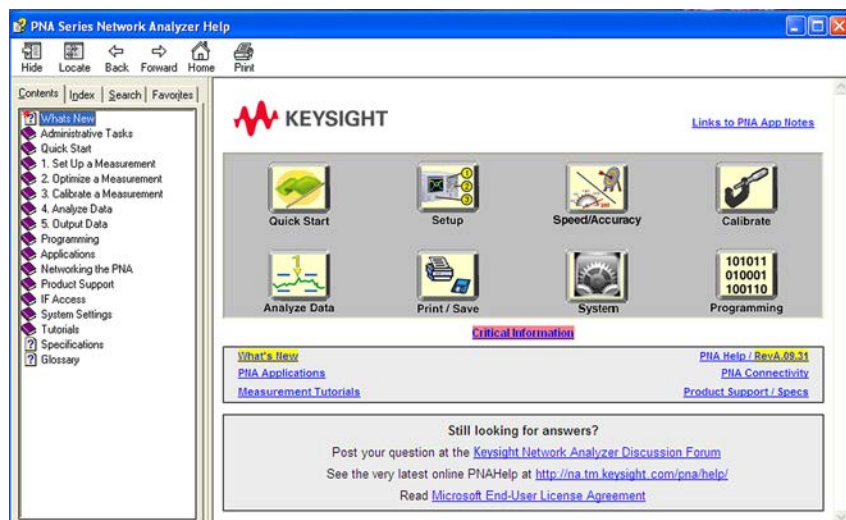

The PNA's built-in help system provides a complete user's guide, including measurement tutorials and programming documentation.

Innovative Features Across the PNA Family

Flexible, modern user interface: front panel keys, tabbed soft panel, pulldown menus, customizable toolbar, right-click shortcuts, drag-and-drop operation, and 12.1" touch screen

Up to 15 markers per trace

State-of-the-art calibration capabilities

200 measurement channels and unlimited traces

Context sensitive, built-in help

Undo/Redo cancels or restores previous entries

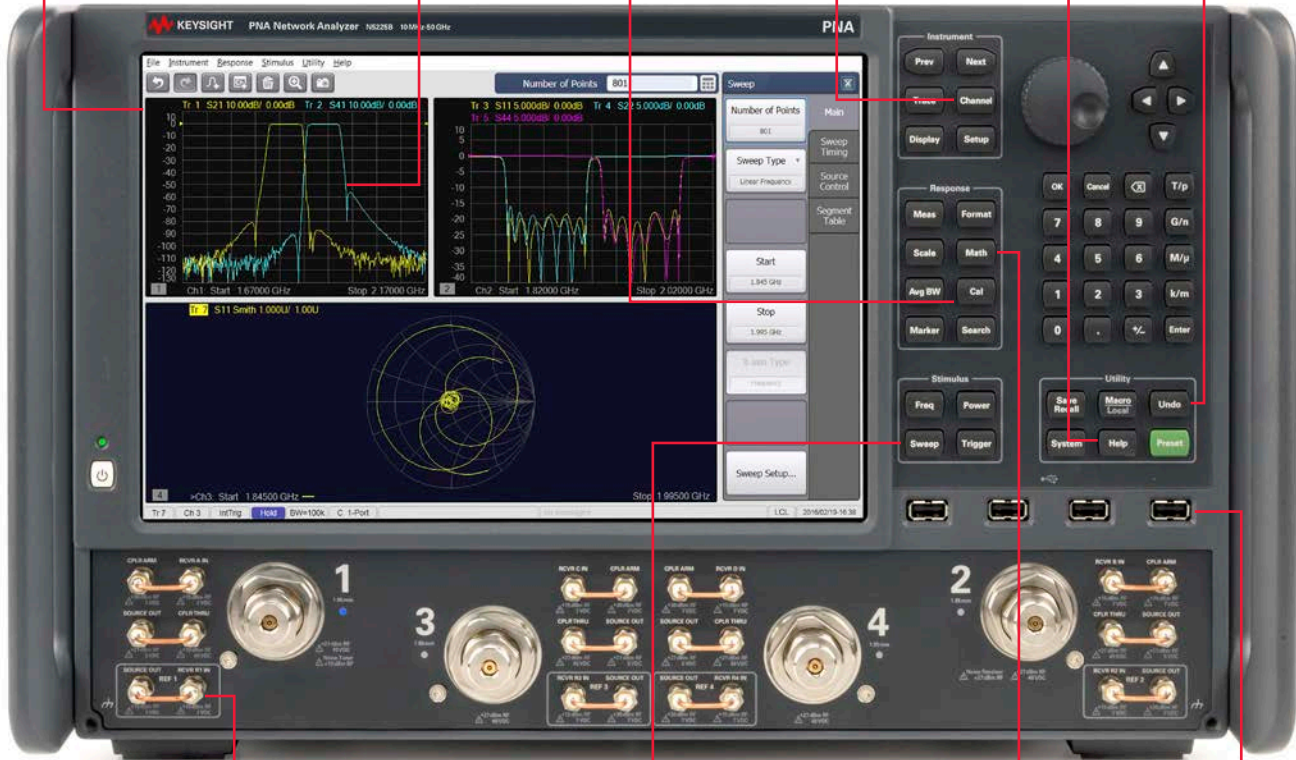

Configurable test set available on all models

Linear, log, power, CW, phase, and segment sweep

Equation editor and time-domain analysis

Quick access for ECal and other USB devices



All PNA models integrate a high resolution display with a touch screen, which provides a crisp view and easy access to all data and traces. This enhanced user interface allows intuitive operation and helps you set up complex measurements quickly.

Connectivity to Match Your Application

Second GPIB interface for controlling signal sources, power meters or other instruments

RF jumpers for adding signal conditioning hardware or other test instruments

Direct IF access for remote mixing in antenna ranges

LAN and device-side USB interfaces provide alternatives to GPIB for remote programming

Removeable solid-state hard drive for secure environments

PNA Series provides advanced connectivity

Pulse I/O connector for controlling external modulators or synchronizing internal pulse generators models

Test set I/O for controlling external multiport and millimeter-wave test sets

Flexible triggers for measurement control and for synchronizing external sources or other instruments

Power I/O connector provides analog inputs and outputs for PAE and other measurements

LAN provides alternative to GPIB programming

GPIB for remote operation

PNA-L Series provides basic connectivity

Material/part handler control port

Test set I/O for controlling external multiport test sets

Aux I/O for triggering, analog I/O, and general purpose digital control

PNA Series

The PNA Series of network analyzers offers industry-leading performance for testing amplifiers, mixers and frequency converters. The PNA Series provides a winning combination of excellent hardware and powerful measurement applications to measure a broad range of devices fast and accurately. All models are available in 2-port single-source and 4-port dual-source versions. Pulsed S-parameters are easy using built-in pulse modulators and pulse generators.

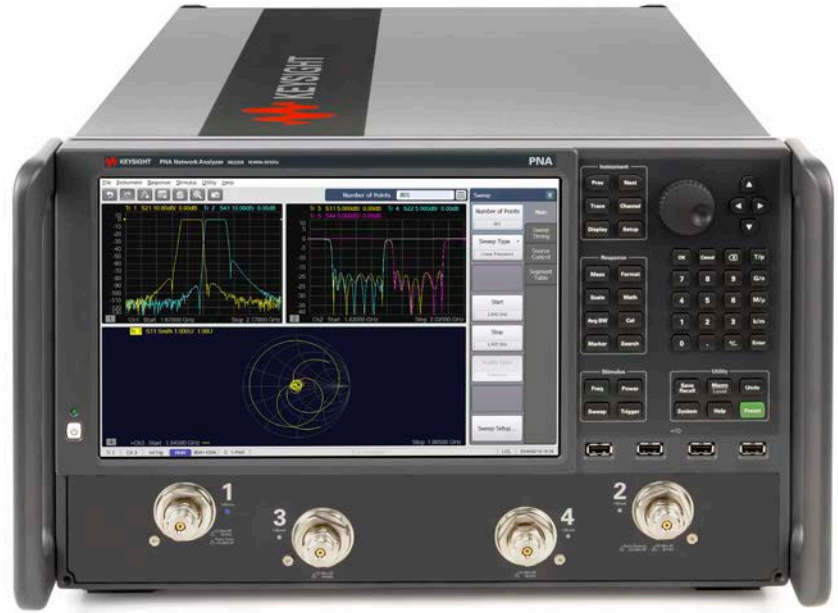

Highest performance

- High source output power of +13 dBm at 1 GHz to +11 dBm at 67 GHz
- High dynamic range: 127 dB at 20 GHz at test port
- Low trace noise: 0.002 dB rms at 1 kHz bandwidth
- Low receiver noise floor
- High receiver compression level
- Fast measurement speed: 3.6 to 23 μ sec/point
- High stability: < 0.03 dB/ $^{\circ}$ C

Advanced applications

Many of the measurement applications developed for the PNA-X are now available for the PNA, such as:

- Pulsed-RF (S93025/26A)
- Gain compression (S93086A)
- Intermodulation distortion (S93087A)
- Noise figure using standard receivers (S93029A)
- Source-phase control (S93088A)
- Differential and I/Q Devices (S93089A)
- True-mode stimulus (S93460A)
- Frequency converters (S93082/83A)
- Embedded-LO (S93084A)
- Automatic fixture removal (S93007A)

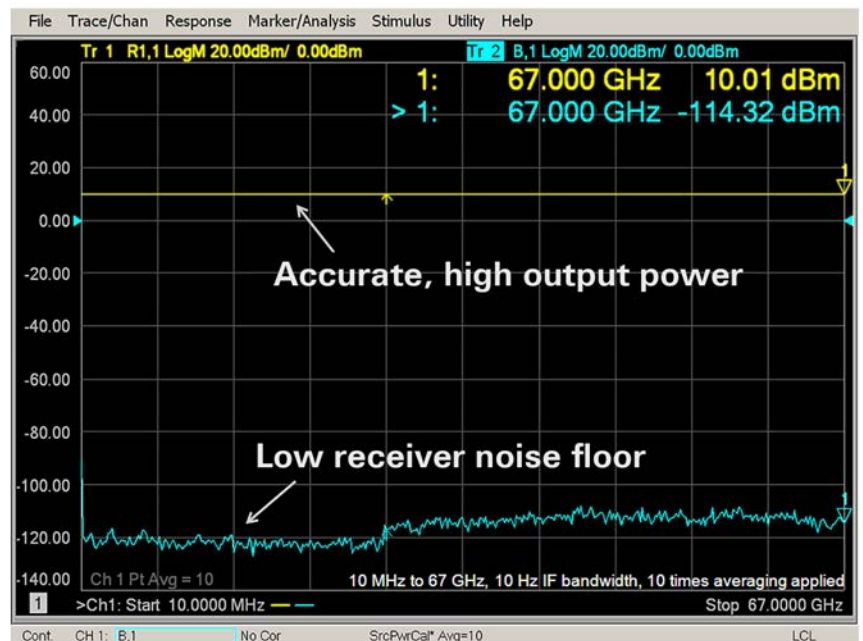

With receiver-leveled output power of +10 dBm and a receiver noise floor of -114 dBm, the PNA typically has 124 dB of dynamic range at 67 GHz, more than any other network analyzer in this frequency range.

PNA Series

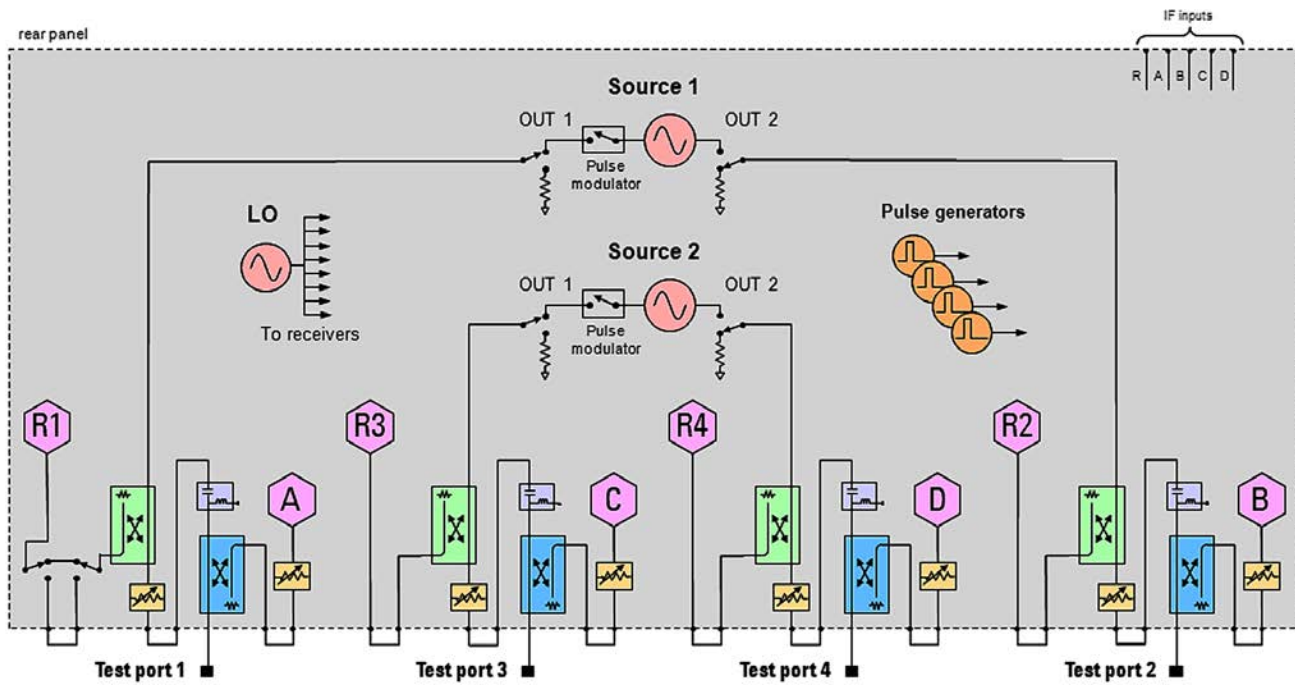

PNA Series block diagram shown with test set Option 419, plus pulse and external-IF options.

Performance	Legacy PNA E836x	New PNA N522x
Port power, 20 GHz	+3 dBm	+13 dBm
System dynamic range, 20 GHz	123 dB	127 dB
Receiver compression, 0.1 dB	-5 dBm	+12 dB
Source power sweep range	27 dB	38 dB
Minimum pulse width, wideband detection	50 us	100 ns

The new PNA Series network analyzers offer significantly better performance compared to legacy models.

Choose the Right Hardware for Your Test Needs

	Legacy PNA-L N5230C/ PNA-L N523xB	Legacy PNA E836x	PNA N522xB	PNA-X N524xB
2-ports, single source	■	■	■	■
2-ports, dual source				■
4-ports, dual source	■ ¹		■	■
Low-harmonic sources (< -60 dBc)				■
Test set without front-panel RF loops	■	■	■	
Test set with front-panel RF loops	■	■	■	■
Switchable rear-panel RF loops				■
Source attenuators	■	■	■	■
Receiver attenuators		■	■	■
Bias tees		■	■	■
External IF inputs		■	■	■
RF, LO outputs for millimeter extenders		■	■	■
Internal pulse modulators			■	■
Internal pulse generators			■	■
IF gates for narrowband pulse detection		■	■	■
R1 reference receiver switch		■	■	■
Internal signal combiner				■
Noise figure using standard receivers			■	■
Noise figure using low-noise receivers				■
Nonlinear vector network analyzer applications				■

1. Dual source is only available on legacy PNA-L N5230C 13.5 and 20 GHz, 4-port.

More information about the PNA-X can be found online at www.keysight.com/find/pna-x or in the PNA-X Seriesbrochure,5990-4592EN

PNA Series Innovative Applications

Simple, fast, and accurate pulsed-RF measurements (S93025/026A, Options 021, 022)

Pulsed-RF measurement challenges

- Pulse generators and modulators required for pulsed-RF measurements add complexity in test setups
- For narrow pulses:
 - Maximum IF bandwidth of analyzer is often too small for wideband detection
 - Narrowband detection is slow, and measurements are noisy for low duty cycle pulses



The PNA is a one-box pulsed-RF test solution that is simple to use and provides fast, accurate pulsed-RF characterization.

PNA pulsed-RF measurements provide:

- S93025A provides a simple user interface for full control of two internal pulse modulators (Options 021 and 022), and four internal independent pulse generators, and point-in-pulse measurements with pulse widths as narrow as 200 ns, and pulse-profile measurements with 50 ns minimum resolution.
- S93026A adds point-in-pulse measurements with 20 ns minimum pulse width, and pulse profile measurements with 10 ns minimum resolution
- Improved measurement speed and accuracy for narrowband detection using hardware filters and patented spectral-nulling and software IF-gating techniques
- Measurements using wideband detection with pulse widths as narrow as 100 ns
- Receiver leveling for accurate source-power control
- Pulse I/O connector on rear panel for synchronization with external equipment and DUT
- Accurate active-component characterization using unique application measurement classes for gain compression, swept-frequency/power IMD, and noise figure

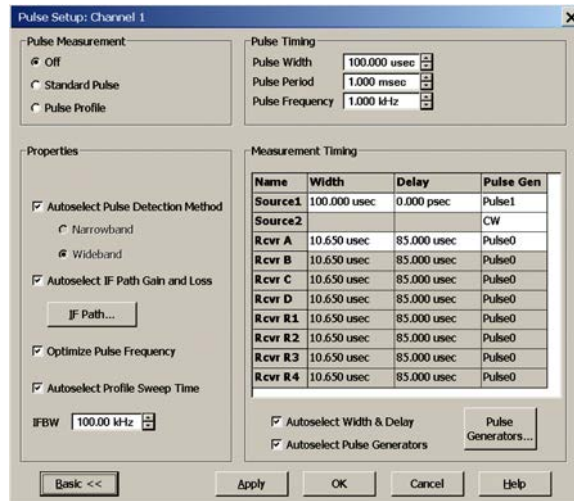

The pulsed-RF measurement application automatically optimizes the internal hardware configuration for specified pulse conditions to dramatically simplify test setups. Alternately, users can choose to manually set up the hardware for unique test requirements.

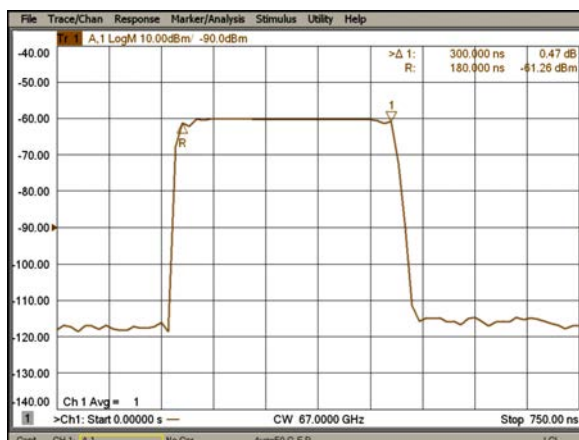

Pulse profile measurement using narrowband detection method allows 300 ns sweep time with 30 data points.

PNA Series Innovative Applications

Fast, accurate gain compression versus frequency measurements of amplifiers and converters (S93086A)

Gain compression measurement challenges

- Characterizing amplifier or frequency converter compression over its operating frequency range requires measurements at many frequency and power points, so setting up the measurements, calibration, and data manipulation takes a lot of time and effort
- A variety of errors degrade measurement accuracy, such as mismatch between the test port and the power sensor and DUT during absolute power measurements, and using linear S-parameter error correction in nonlinear compression measurements

PNA gain compression application (GCA) provides:

- Fast and convenient measurements with SMART Sweep, which greatly reduces the number of power points required to fully characterize compression versus frequency
- Highly accurate results using a guided calibration that provides power and mismatch correction
- Complete device characterization with two-dimensional (2D) sweeps, with the choice of sweeping power per frequency, or frequency per power
- Flexibility with a variety of compression methods—compression from linear gain, maximum gain, X/Y compression, compression from back-off, or compression from saturation

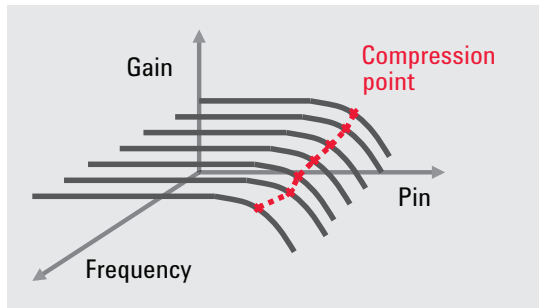

A network analyzer is commonly used for gain compression measurements by performing power sweeps at multiple CW frequencies. The PNA's GCA makes it easy to characterize compression over the DUT's operating frequency range with extreme speed and accuracy, and a simple setup.

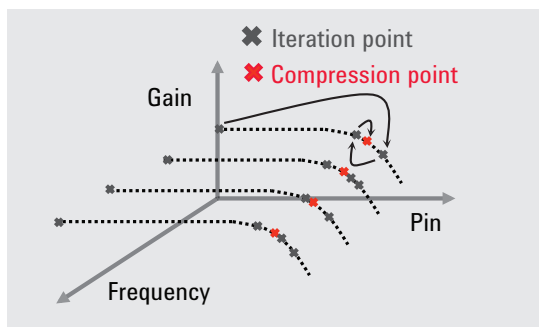

Instead of a linear power sweep with many points, GCA's SMART Sweep uses an adaptive algorithm to find the desired compression point at each frequency with just a few power measurements, thus significantly reducing test times.

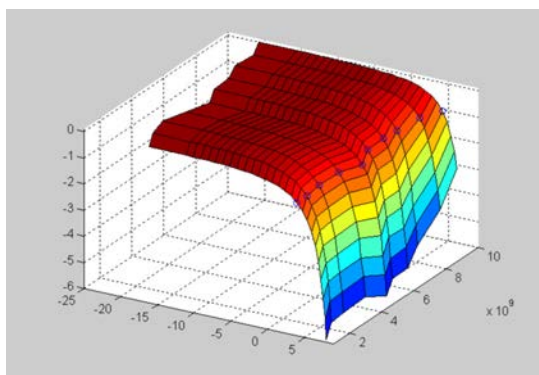
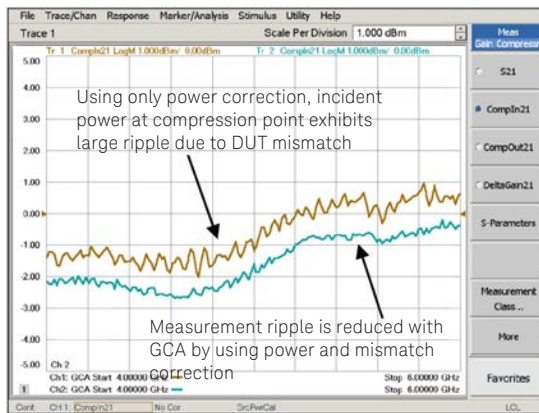

Complete device response to 2D sweeps—gain versus frequency and power—can be extracted for device modeling.

PNA Series Innovative Applications

Fast two-tone intermodulation distortion (IMD) measurements with simple setup (S93087A)

IMD measurement challenges

- Two signal generators, a spectrum analyzer, and an external combiner are most commonly used, requiring manual setup of all instruments and accessories
- Test times are slow when swept-frequency or swept-power IMD is measured
- Instruments and test setups often cause significant measurement errors due to source-generated harmonics, cross-modulation, and phase noise, plus receiver compression and noise floor

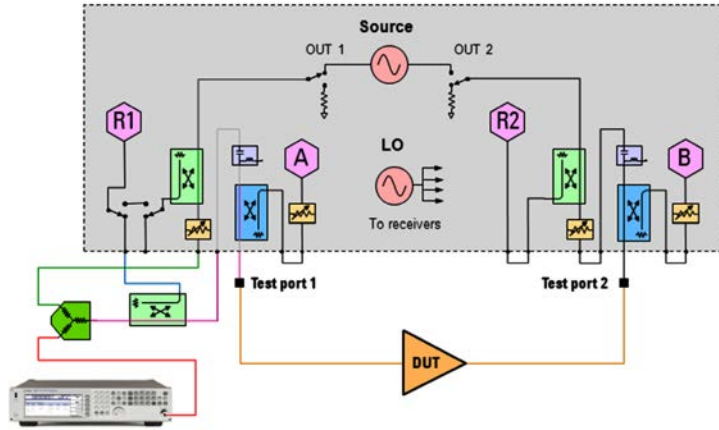

A 2-port PNA can be used with an external signal source, combiner and coupler for IMD measurements.

PNA IMD application provides:

- Fast swept-IMD measurements of amplifiers and frequency converters
- Quick and easy measurements with an intuitive user interface
- Guided calibration that simplifies the calibration procedure and provides high measurement accuracy
- Spectrum analyzer mode for troubleshooting or making spurious measurements, eliminating the need for a separate spectrum analyzer

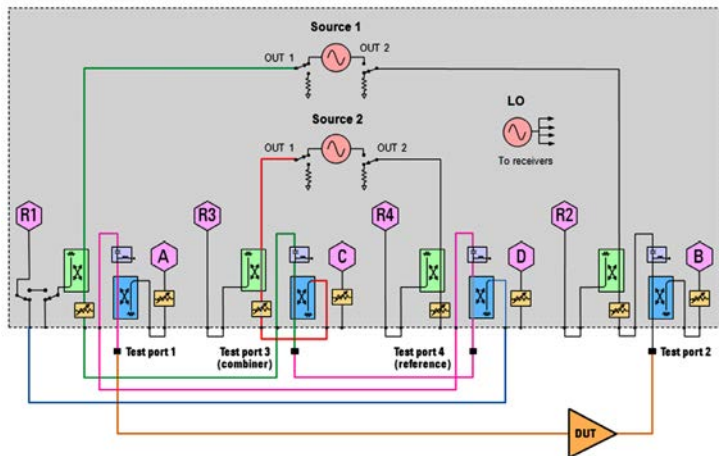

On a 4-port PNA, the two internal sources can be used to create the IMD stimulus. Unused test port couplers can be used as a combiner and reference coupler.



IMD application measures third order IMD and IP3 at 201 frequency (or power) points in a matter of seconds, compared to several minutes using signal generators and a spectrum analyzer.

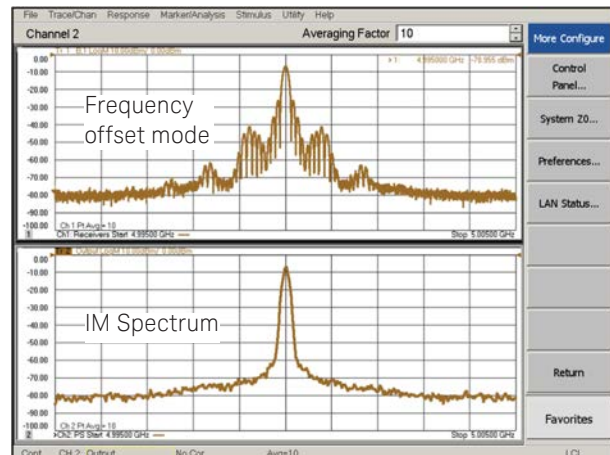

Frequency-offset mode is commonly available in VNA's, but conventional IF filter responses exhibit high side lobes. The IM Spectrum mode employs an optimized digital-IF filter along with software preselection, to provide true spectrum measurement capability in the PNA. A faster and more capable spectrum analyzer application is available with S93090xA.

PNA Series Innovative Applications

Fast and accurate noise figure measurements (S93029A)

Noise figure measurement challenges with traditional, Y-factor approach

- Multiple instruments and multiple connections required to fully characterize DUT
- Measurement accuracy degrades in fixtured, on-wafer, and automated-test environments, where noise source cannot be connected directly to DUT
- Measurements are slow, often leading to fewer measured data points and misleading results due to under-sampling

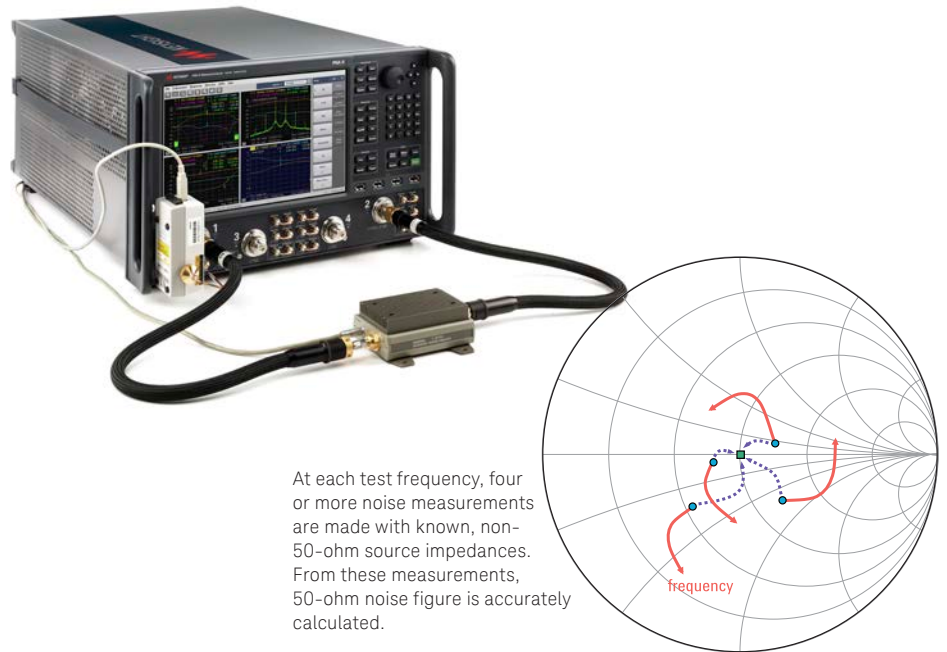

PNA noise figure solution provides:

- Amplifier and frequency converter measurements with the highest accuracy in the industry, using advanced error-correction methods
- Correction for imperfect system source match by using vector correction to remove mismatch errors plus an ECal module used as an impedance tuner to remove noise-parameter-induced errors
- High measurement accuracy in fixtured, on-wafer, or automated-test environments
- Fast measurements: typically 4 to 10 times faster than Keysight's NFA Series noise figure analyzers
- Accurate measurements of differential devices using vector deembedding of baluns or hybrids

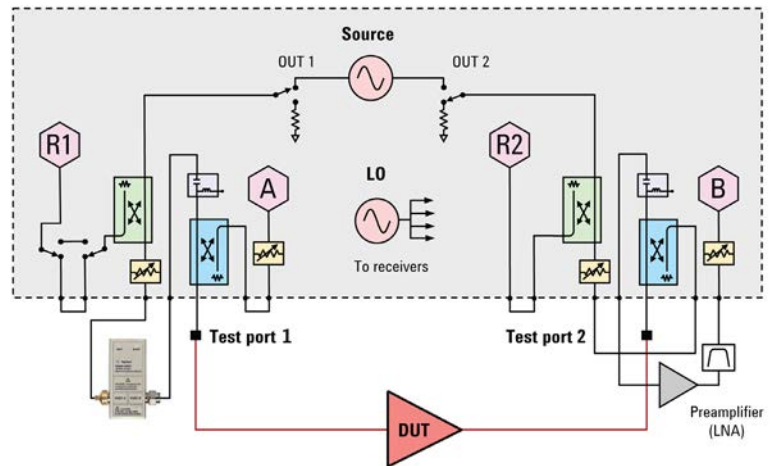

PNA noise figure measurement setup using an ECal module as an impedance tuner, and an external LNA and filter for improved sensitivity and measurement accuracy.

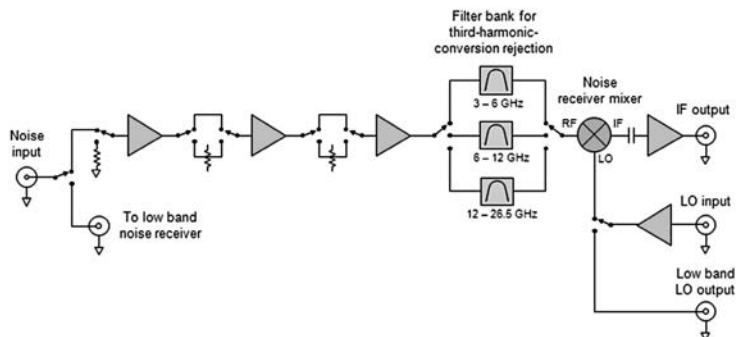

For wideband noise figure measurements, Keysight recommends a PNA-X with low-noise receiver Option 029, which includes built-in LNAs, harmonic-rejection filters, and for 44.5/50/67 GHz models, a built-in impedance tuner.

PNA Series Innovative Applications

Fast, high-gamma active-load amplifier characterization (S93088A)

Load-characterization measurement challenges

- Handling high-power DUTs
- Mechanical tuners cannot supply fully reflective loads and are slow

PNA source-phase control application provides:

- Fast active-loads using built-in second source or an external source
- Full reflection with user-defined fixed or swept phase angles
- Measurements of amplifier output power, match, and gain under different load conditions
- Hybrid setups that combine mechanical and active tuning for fundamental and harmonic load pull

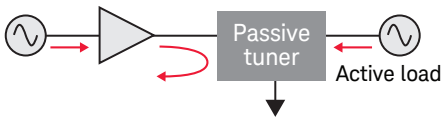

In a hybrid load-pull setup, the passive tuner provides the majority of the reflected signal, so the power required of the active load for full reflection is much lower.

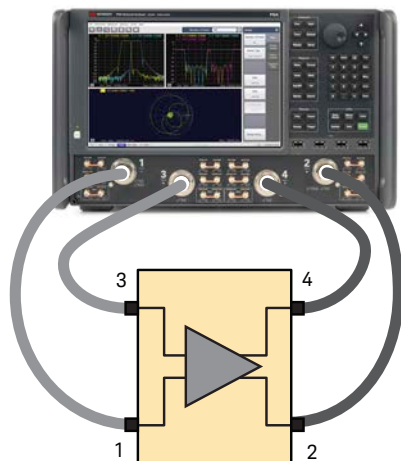

Using the PNA's two internal sources, iTMSA drives the differential amplifier under real world conditions, providing accurate mixed-mode S-parameters in all operating environments.

Simplified test of I/Q converters and modulators, and differential mixers (S93089A)

I/Q and differential converter measurement challenges

- Requires signals with 90° or 180° phase difference
- Traditional approach uses hybrid couplers and/or baluns which are:
 - Inherently band-limited, requiring multiple components for broadband measurements
 - Limited to fixed phase offsets, preventing phase sweeps to determine optimum alignment
 - Lossy and inaccurate ($\pm 3^\circ$ to 12° typically)
 - Difficult to use with on-wafer setups

PNA-X differential and I/Q devices application

- Provides accurate phase control of internal and external sources, eliminating the need for hybrid couplers and baluns
- Tunes receivers to all user-specified output frequencies needed to fully characterize the DUT
- Sweeps frequency to measure operating bandwidth or sweeps phase and power at a fixed frequency to measure quadrature or differential imbalance
- Includes match-corrected power measurements for highest accuracy

Testing differential amplifiers under real operating conditions (S93460A)

Differential amplifier measurement challenges

- Conventional two-port VNAs with baluns do not provide common-mode and mixed-mode responses
- Baluns are inherently band-limited devices, which forces multiple test setups for broad frequency coverage
- Phase errors of baluns provide inaccurate differential responses
- Modern four-port VNAs provide mixed-mode S-parameter measurements with single-ended stimulus, but differential amplifiers may respond differently when in compression during real operating environments

PNA integrated true-mode stimulus application (iTMSA) provides:

- Mixed-mode S-parameters of differential amplifiers driven by true differential and common-mode signals
- Mismatch correction at the DUT input to minimize phase and amplitude errors between the two sources
- Input-only drive mode that prevents damage to amplifiers caused by stimulus on the output port
- In-fixture arbitrary phase offset and phase-offset sweeps to optimize input matching network for maximum amplifier gain

PNA Series Innovative Applications

Accurate characterization of mixers and converters (S93082/83A)

Mixer and converter measurement challenges

- Traditional approach with spectrum analyzer and external signal sources is cumbersome, slow, and does not provide phase or group delay information
- Conventional VNAs require an external signal source, which degrades sweep speed
- Conventional VNAs provide phase or group delay data relative to a "golden" device
- Attenuators are often used to minimize ripple due to input and output mismatch, at the expense of dynamic range and calibration stability

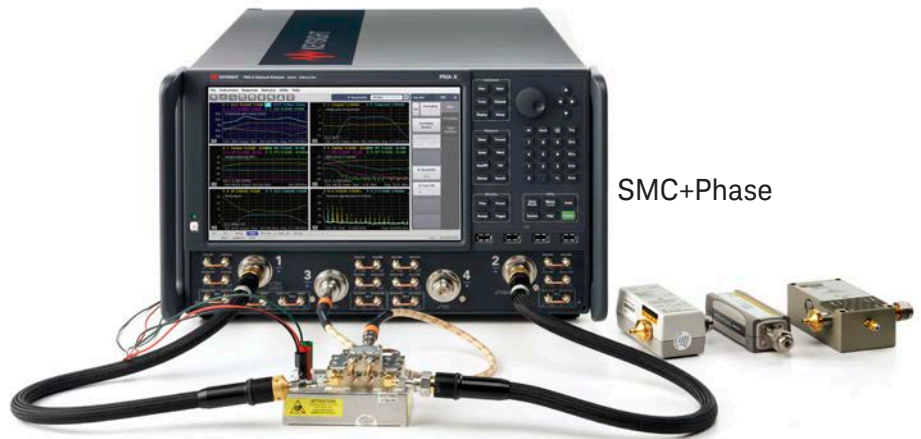

SMC+Phase

S93083A Scalar Mixer/Converter plus Phase (SMC+Phase) makes mixer and converter measurements simple to set up since reference and calibration mixers are not required. Calibration is easy to perform using three broadband standards: a power meter as a magnitude standard, a comb generator as a phase standard, and an S-parameter calibration kit (mechanical or ECal module).

PNA frequency converter applications provide:

- Simple setup using internal second signal source as a local oscillator (LO) signal
- Typical measurement time improvement of 100x compared to spectrum analyzer-based approach
- High measurement accuracy using two patented techniques:
 - Scalar mixer/converter (SMC) provides match and most accurate conversion loss/gain measurements by combining two-port and power-meter calibrations (S93082A), and with S93083A, calibrated absolute group delay measurements without a reference or calibration mixer
 - Vector mixer/converter (VMC) provides measurements of match, conversion loss/gain, delay, phase difference between multiple paths or devices, and phase shifts within a device, using a vector-calibrated through mixer (S93083A)
- Input and output mismatch correction reduces ripple and eliminates the need for attenuators

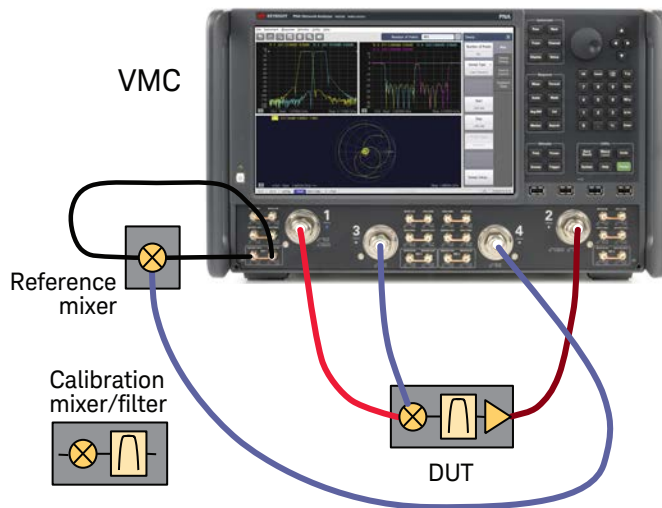

The vector mixer/converter technique provides measurements of match, conversion loss/gain, delay, phase difference between multiple paths or devices, and phase shifts within a device.

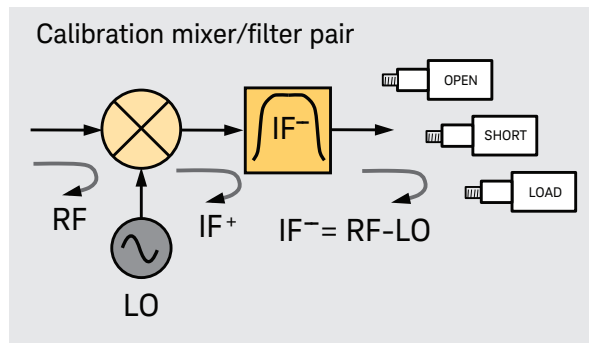

Keysight's frequency converter application vector-mixer- characterization method uses open, short, and load standards and reflection measurements to create a characterized, frequency-translating through standard.

PNA Series Innovative Applications

Measuring Converters with Embedded LOs (S93084A)

Embedded-LO application

- Uses coarse- and fine-tuning sweeps to calculate LO deviation from nominal value
- Automatically tunes the PNA receivers to correct for DUT LO drift, sweep by sweep
- Works with:
 - Noise figure application, S93029A
 - Scalar mixer/converter application, S93082A
 - Frequency converter application, S93083A
 - Gain compression application, S93086A
 - Intermodulation distortion application, S93087A

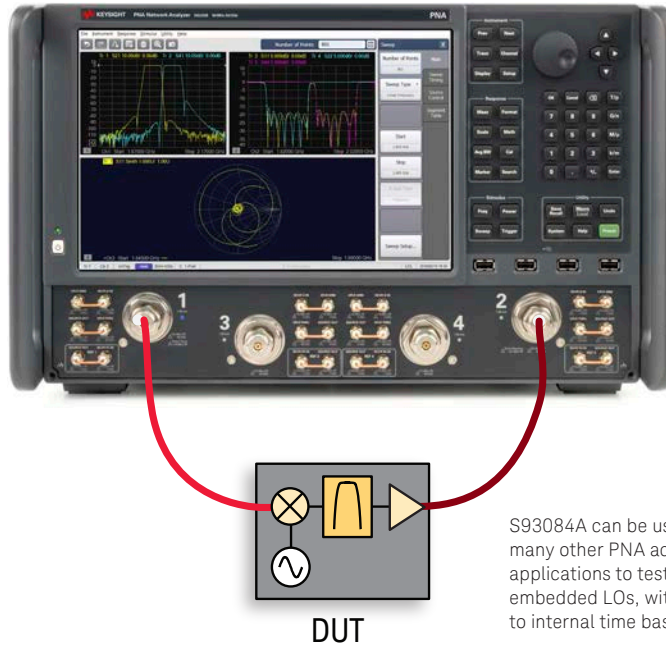

S93084A can be used in conjunction with many other PNA active-measurement applications to test converters with embedded LOs, without need for access to internal time bases.

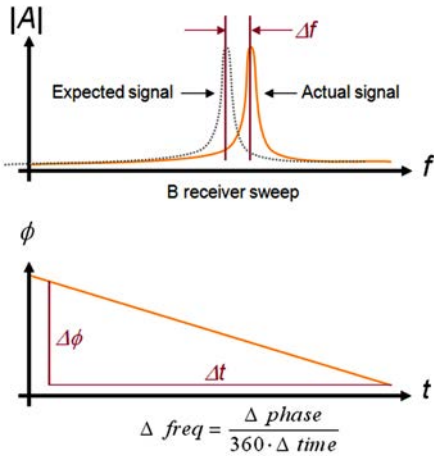

S93084A uses a coarse frequency sweep (top) to determine the nominal LO offset. A phase-versus-time sweep (bottom) is used to fine-tune the estimate of LO offset.



Comparing converter measurements with a locked and unlocked LO shows excellent measurement correlation. Averaging and modest amounts of smoothing are often used to increase accuracy and precision when measuring devices with embedded LOs.

PNA Series Innovative Applications

One-box solution for high-speed serial interconnect analysis (S93011A)

TDR measurement challenges

- As bit rates of digital systems increase, fast and accurate analysis of interconnect performance in both time and frequency domains is critical to ensure reliable system performance
- Managing multiple test solutions to completely characterize differential high-speed digital devices is difficult



PNA TDR application provides:

- One-box solution for high-speed interconnect analysis, including impedance, S-parameters, and eye diagrams

Simple and intuitive operation

- The user interface is designed to provide a similar look and feel to traditional TDR oscilloscopes

Fast and accurate measurements

- Accurate measurements due to unmatched performance of the PNA-X / PNA / PNA-L Series vector network analyzers
- State-of-the-art error correction techniques enables you to measure your device, not your measurement system

High ESD robustness

- Protection circuits implemented inside the instrument significantly increases ESD robustness, while at the same time maintaining excellent RF performance
- Highly robust architecture minimizes instrument failure from ESD and frees you from worrying about instrument repair fees and downtime

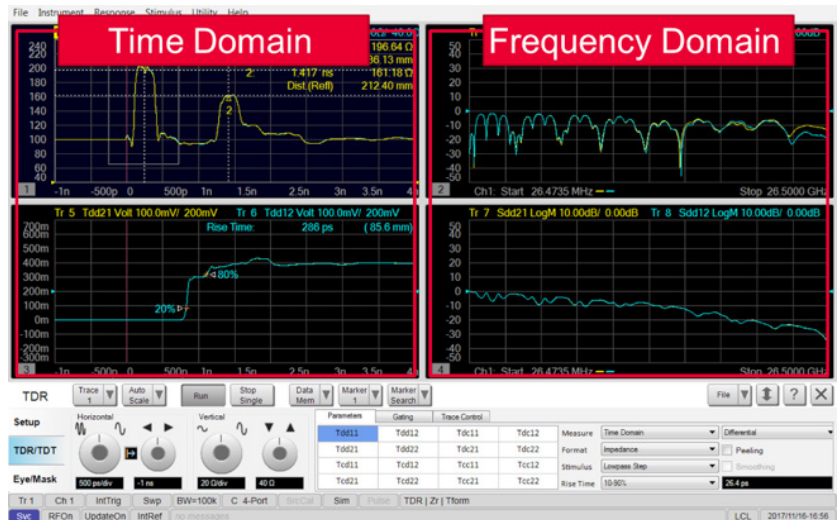

Measurements are taken as a function of frequency. The frequency domain information is used to calculate the Inverse Fourier Transform for time domain results.

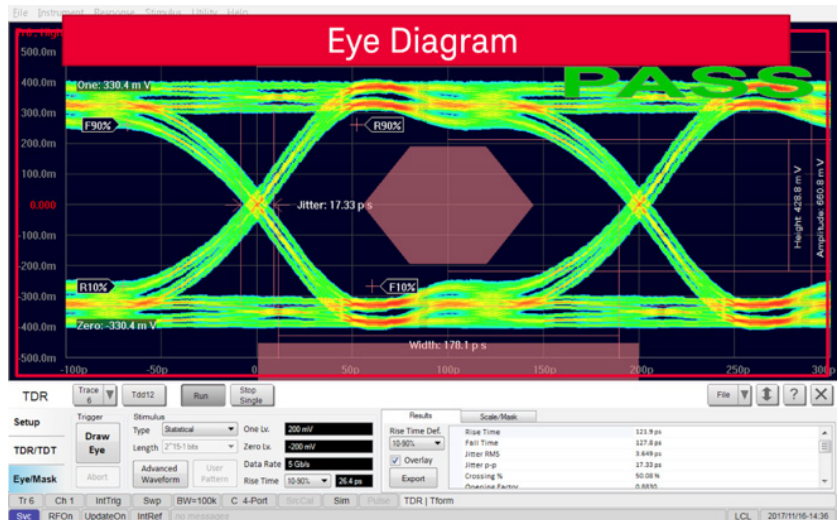

The simulated eye diagram analysis capability eliminates the need for a pulse pattern generator.

PNA Series Innovative Applications

Extending the PNA to millimeter-wave frequencies

PNA's unique hardware architecture provides:

- Single-sweep millimeter-wave network analyzer configurations with frequency coverage from 900 Hz to 120 GHz
- Two- and four-port solutions for measurements on a wide variety of single-ended and balanced millimeter-wave devices
- Differential and I/Q measurements at millimeter-wave frequencies using two, phase-controlled internal sources
- Fully integrated solution for millimeter-wave pulsed-RF measurements using built-in pulse modulators and pulse generators
- Accurate leveled power at millimeter-wave frequencies with advanced source-power calibration methods
- Two internal sources allow direct connection of THz frequency-extender modules



Two- and four-port banded solutions

The N5262A millimeter-wave test-set controller connects four millimeter-wave test modules to the PNA. For two-port measurements, the N5261A millimeter-wave test-set controller is available.



Two- and four-port broadband, single-sweep solutions (900 Hz to 120 GHz)

N5290/91A PNA-based 120 GHz millimeter-wave network analyzers are only available in two-port configurations. Four-port solutions are available using a four-port PNA-X network analyzer. N5290/91A broadband systems provide test capability to fully characterize passive, active, and frequency converting devices. These systems are compact replacements for N5251A systems, with superior performance and wider frequency range.

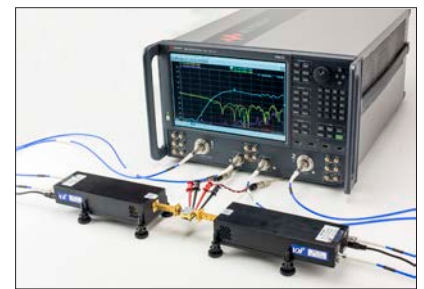

Terahertz solutions without a test set

Direct connection of VDI modules to a four-port PNA enables S-parameter measurements to 1.5 THz.

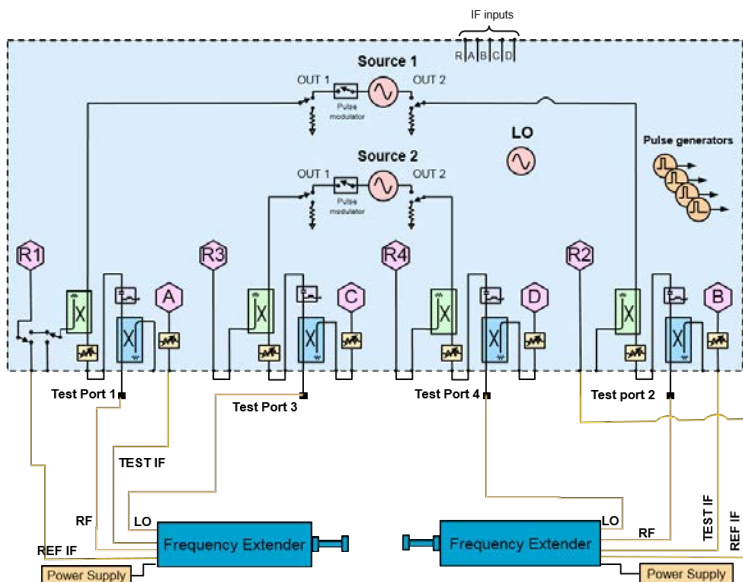

Two-port direct-connect system architecture

Block diagram of a two-port millimeter-wave system using a four-port PNA and two millimeter-wave frequency extenders.

PNA Series Innovative Applications

Millimeter-wave applications with the PNA

Millimeter-wave spectrum analysis

PNA-based millimeter-wave systems can take full advantage of spectrum analysis applications. This capability enables high-order harmonic and spur measurements at millimeter-wave frequencies.

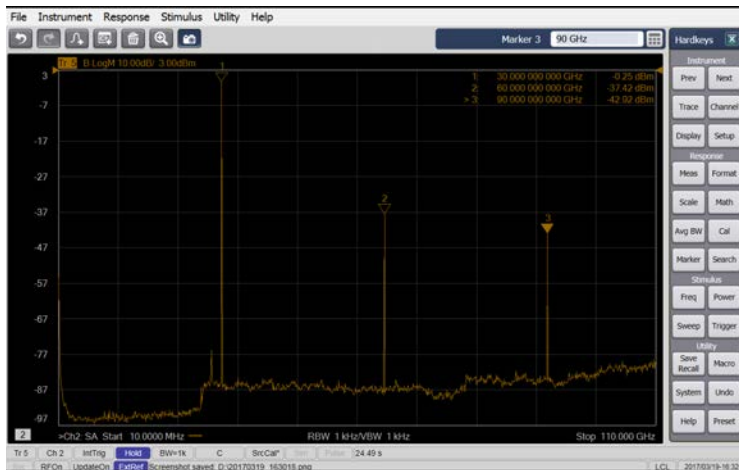

The PNA's spectrum analyzer application is used to measure the harmonics of a millimeter-wave amplifier.

Multi-channel measurements at millimeter-wave frequencies

Fully characterize active devices at millimeter-wave frequencies using multiple PNA software applications, with a single set of connections or wafer touch-downs. Calibration of multi-channel setups is easy using the Cal All Channels feature.



In addition to S-parameters, the spectrum analysis, gain compression, and differential I/Q applications are used to characterize a 10 MHz to 125 GHz amplifier.

Scalar mixer measurements

Measure conversion loss or gain plus input and output matches of mixers and frequency converters at millimeter-wave frequencies.

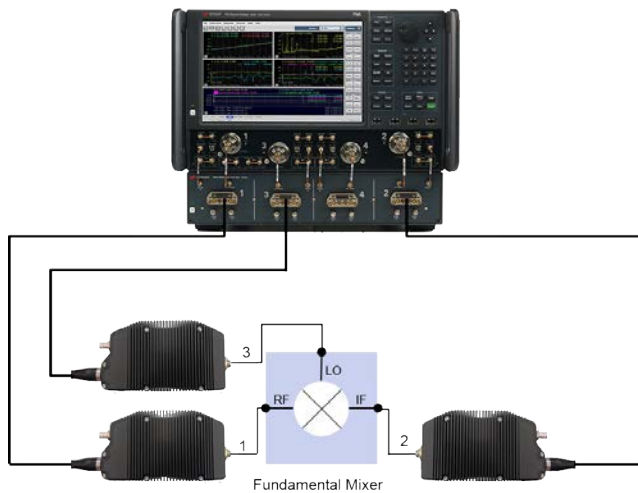

A dual-source PNA with an N5292A four-port controller and broadband frequency-extender modules characterize mixers and converters at millimeter wave frequencies. The PNA's second source can be used to provide an LO signal to a mixer.

Differential and I/Q measurements at millimeter-wave frequencies

- Highest measurement accuracy in the industry using advanced error-correction methods
- Integrated phase sweeps with power control

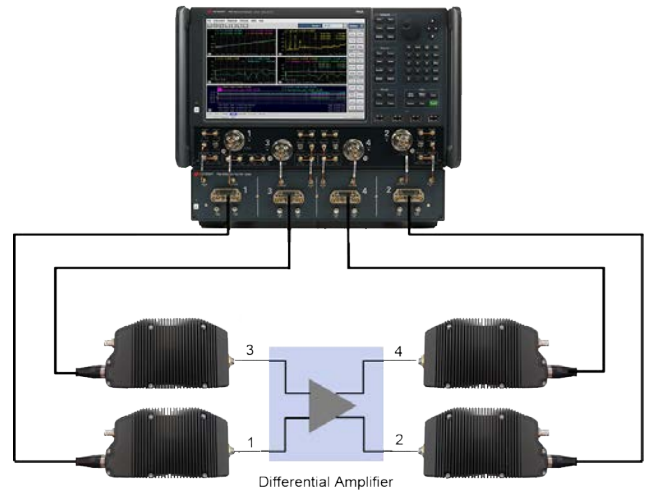

True-differential measurement of a balanced trans-impedance amplifier using a four-port PNA, the N5292A controller, and N5293A frequency extenders.

PNA-L: Passive and Active Device Test at Affordable Prices

The Keysight PNA-L is designed for your general-purpose network analysis needs and priced for your budget. With the same core firmware as the PNA, the PNA-L offers the perfect balance of value and performance. The PNA-L provides efficiency and flexibility in both manufacturing and R&D applications, for industries ranging from mobile-telecomm and wireless-LAN component production to aerospace and defense.

Balanced/differential components

For passive devices that have one or more balanced/differential ports, the PNA-L is an excellent choice for mixed-mode S-parameter measurements, without the need or limitations of using baluns.

- Display differential-, common-, and mixed-mode performance, in a variety of trace formats
- Measurement parameters include common-mode-rejection ratio and amplitude and phase imbalance
- Supported port configurations include single-ended-to-balanced and balanced-to-balanced topologies

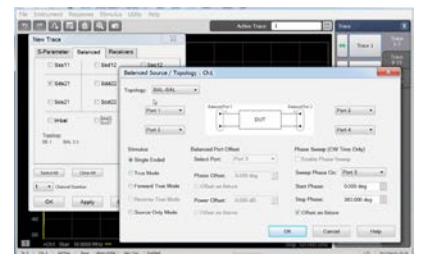
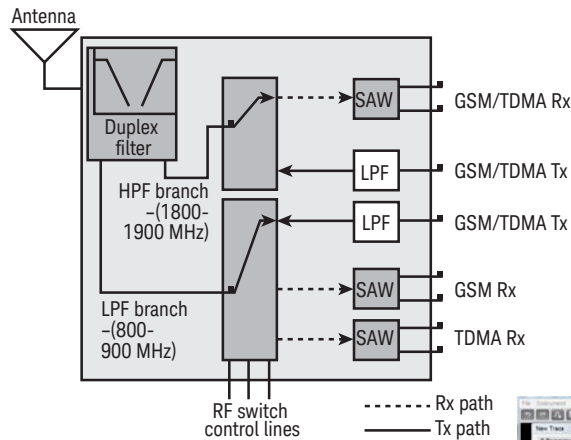

PNA-L Series Block Diagrams

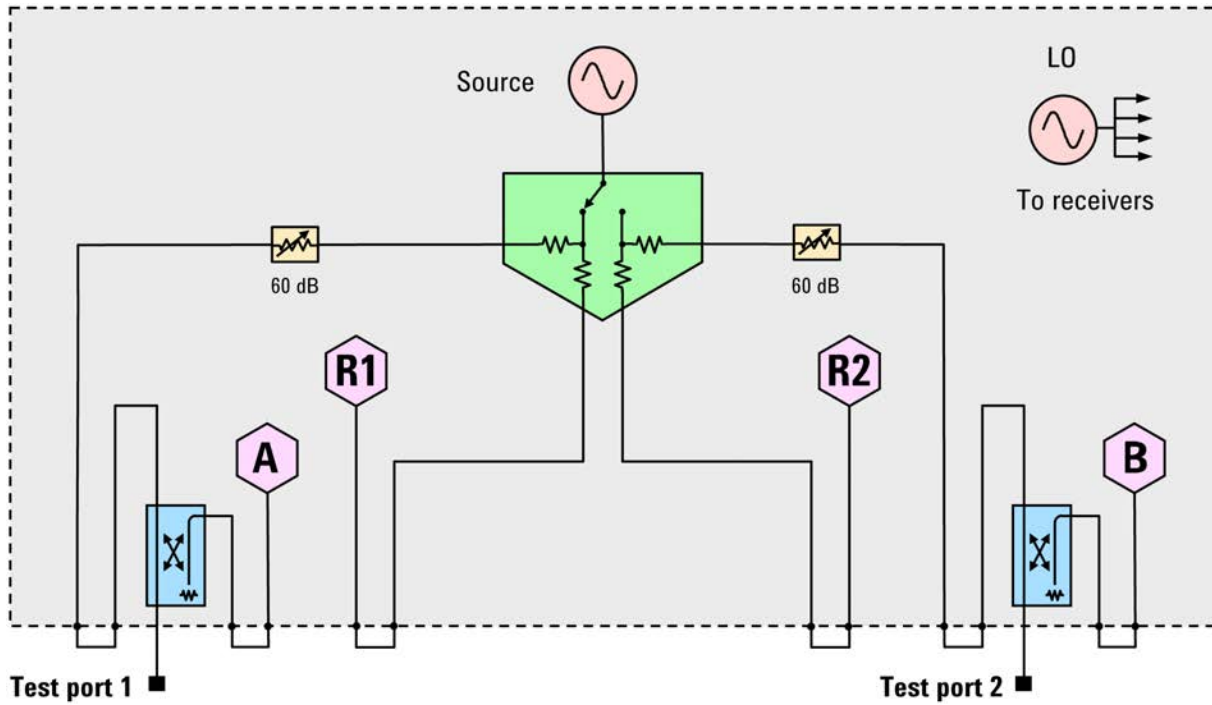

PNA-L Series 2-port block diagram shown with test set Option 216.

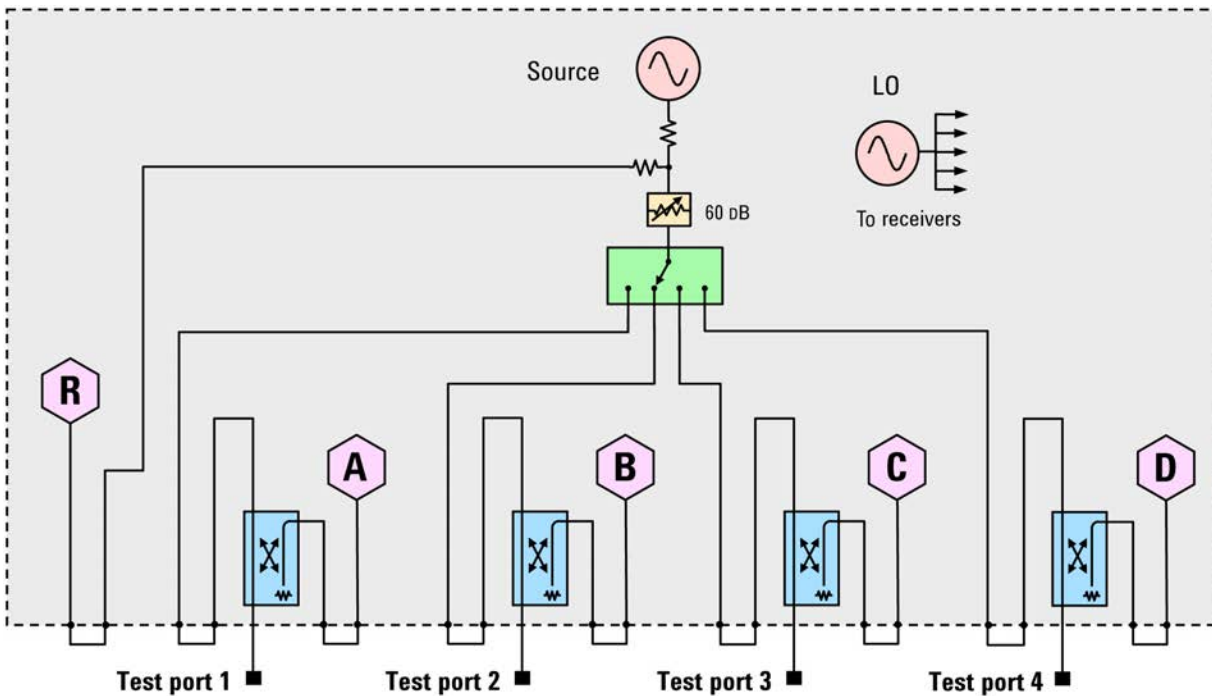

PNA-L Series 4-port block diagram shown with test set Option 416.

PNA-L Series: The Economical Choice for Signal Integrity and Material Measurements

Physical Layer Test Software (PLTS)

The Keysight PNA-L is the ideal microwave engine to power PLTS software.

PLTS provides:

- Forward and reverse reflection and transmission measurements, with time- and frequency-domain displays targeted specifically for signal-integrity analysis
- Guided setup, calibration, and data acquisition
- Full modal analysis including single-ended, differential, and cross-mode conversions
- A powerful, virtual bit-pattern generator to create eye diagrams based on measured channel data
- Highly accurate RLCG models to enhance the accuracy of your models and simulations
- Automatic fixture removal for symmetric and asymmetric fixtures
- Advanced formula editor for user-defined equations such as power sums for crosstalk-compliance measurements

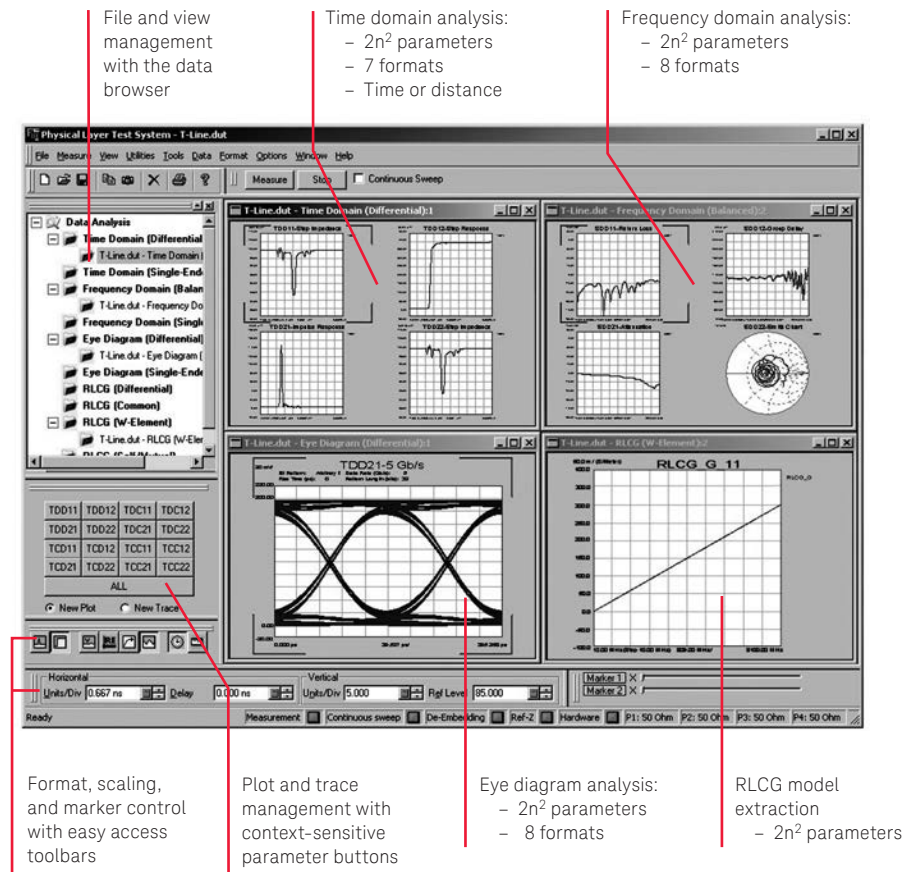

PLTS provides a wealth of analysis tools for signal-integrity engineers.

Materials measurements

Keysight offers several tools to help determine the intrinsic electromagnetic properties of materials, including N1500A materials measurement software, N1501A dielectric probe kit, 16451B/2A/3A/4A Material Test Fixture, N1501AExx Split Post Dielectric Resonator, and 85072A split cylinder resonator. The complete system is based on a versatile Keysight network analyzer like the PNA-L, LCR meters, and impedance analyzers, which measures the material's response to DC, RF or microwave energy.

Keysight material measurements solutions provide:

- Control of the network analyzer to automate complex permittivity and permeability measurements versus frequency
- Display of results in a variety of formats (ϵ_r , ϵ_r'' , $\tan \delta$, μ_r , μ_r'' , $\tan \delta_m$ and Cole-Cole)
- A variety of measurement methods and mathematical models to meet most application needs
- Support for many different probes and fixtures, as well as free-space measurements
- Data easily shared with other Windows-based programs or through the component object model (COM) interface

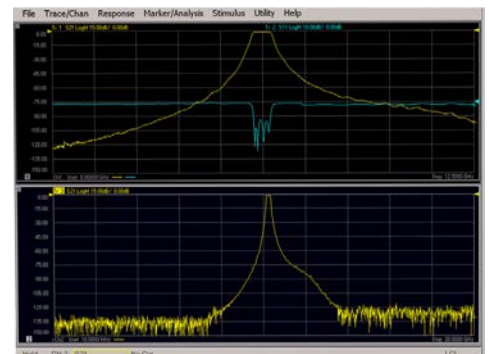

On-Wafer Measurements with the PNA Family

PNA and PNA-L network analyzers can easily be integrated with a microwave probe station to form a complete on-wafer measurement system. All of the PNA's powerful measurement applications can be used for on-wafer devices. When calibration requires a power sensor, the PNA firmware guides the user through the steps required to align power and S-parameter calibration planes into a single set of on-wafer reference planes.

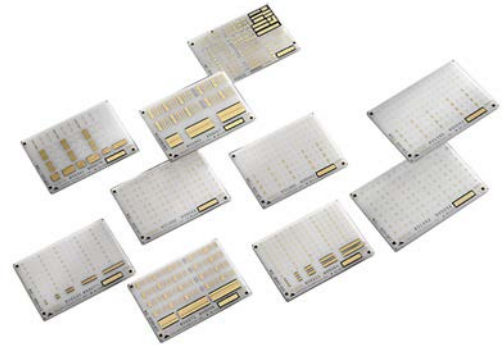

PNA-based on-wafer solutions provide:

- Measurements on filters, amplifiers, and frequency converters
- Complete set of TRL-class calibrations for accurate measurements
- Differential measurement capability using single-ended or true-mode stimulus
- Accurate power-level control for precise power measurements
- Probe-characterization macro to easily measure S-parameters of probes for deembedding

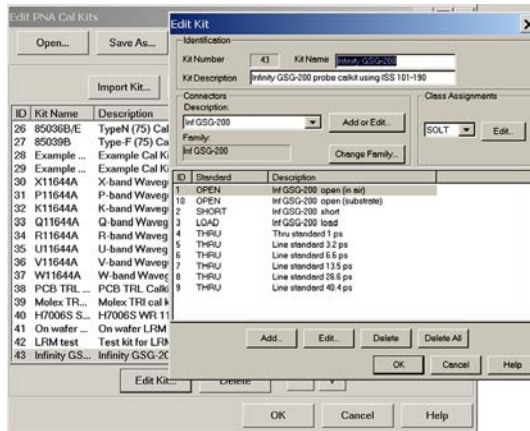

The PNA cal kit editor makes it easy to enter impedance-substrate standard (ISS) definitions for on-wafer calibration

Complete wafer-probe solutions from Cascade Microtech

Cascade Microtech is the worldwide leader for high-quality microwave probing systems and is an official Keysight Solutions Partner. Cascade offers a broad variety of test stations and probes to cover any application and frequency range. In addition, WinCal XE software enhances RF measurement accuracy and productivity through guided system setup, automatic calibration and validation, test sequencing, and other advanced RF measurement tools.

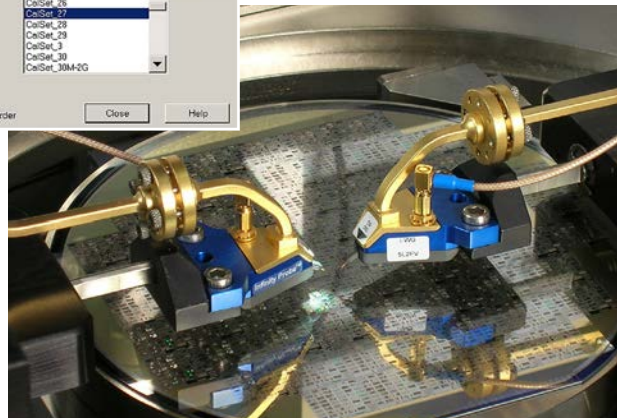
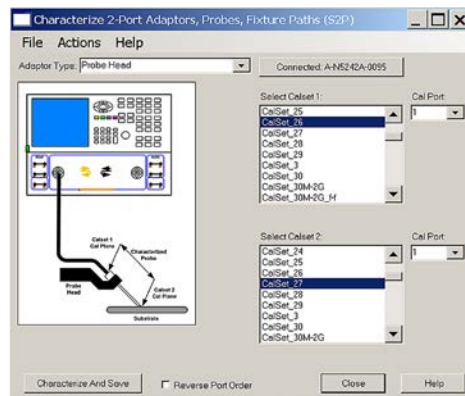

Extend the Power of the PNA Family to Multiport Devices

Multiport test challenges:

- Many components have more than 4 ports
- Moving test cables is slow and prone to errors
- Standard two-port calibration doesn't correct for ports outside the test path, resulting in degraded accuracy

PNA and PNA-L multiport solutions provide:

- Integrated test systems consisting of a network analyzer and an external multiport test set, seamlessly controlled by the PNA's firmware
- A single set of test connections to the DUT, resulting in high test throughput
- High accuracy with advanced calibration methods.
- Full compatibility with PLTS

Flexible test set hardware

- Test couplers on each port provide accurate and stable measurements
- External signal conditioning hardware such as attenuators, amplifiers, or isolators can be added as needed to handle a variety of device types
- Get full cross-bar switching to cover any DUT, or limit the test paths to match those required by a specific DUT

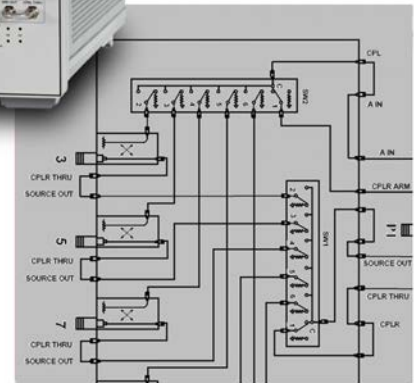

Advanced calibration

- N-port calibration corrects the load match at all ports of the DUT, whether they are in the test path or not. This gives a high level of accuracy, independent of the isolation between ports of the DUT.
- QSOLT (quick short, open, load, thru) calibration reduces the number of correction standards required for full N-port calibration
- Application-specific calibrations to support compression, IMD, and noise figure can be applied in conjunction with the test set

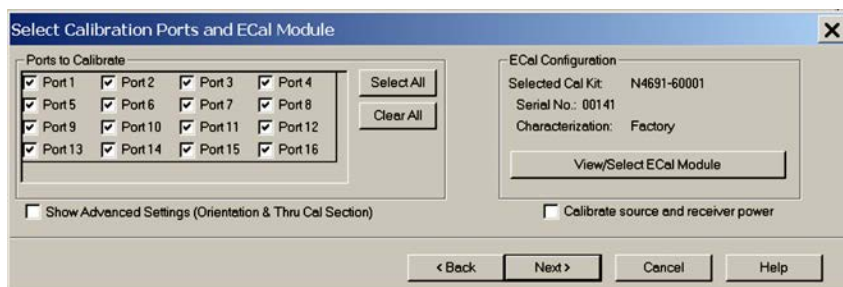

Completing the Solution

Advanced calibration tools

Calibrating network analyzers is critical for high accuracy measurements and can be particularly challenging in non-coaxial environments such as in-fixture, on-wafer, or waveguide. The PNA family supports a broad range of mechanical and electronic calibration kits, and offers advanced calibration methods to enhance ease-of-use while providing best-in-class accuracy. Keysight calibration tools include:

- High-performance two-and four-port ECal modules, covering 300 kHz to 67 GHz, with nine connector types
- QSOLT and n-port calibration for multiport test systems
- Data-based calibration-standard models and expanded math for enhanced accuracy at high frequencies
- Match-corrected power measurements to eliminate mismatch errors
- Software fixturing for deembedding, port matching, and impedance transformation

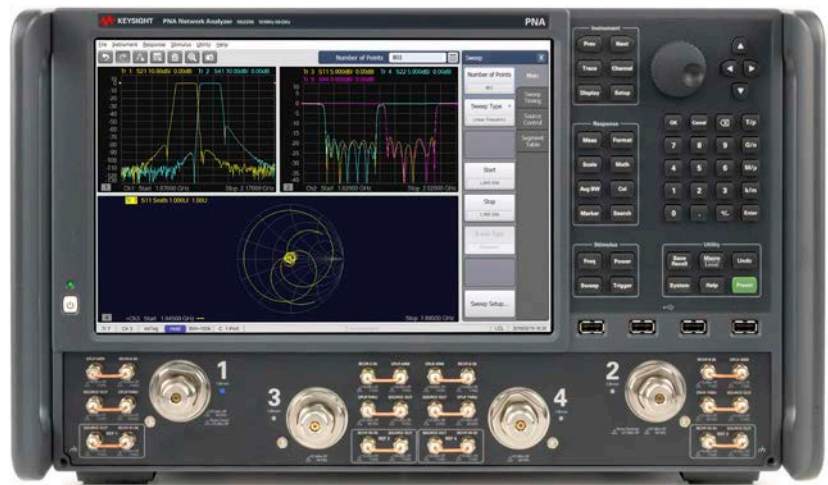

Protect your software investment

Keysight protects your 8753, 8720 and 8510 software investment by providing migration tools to reduce your code conversion effort.

www.keysight.com/find/nadisco

Network analyzer forum

Visit the online network analyzer discussion forum where you can learn how your peers are solving some of their most challenging measurement problems.

www.keysight.com/find/na_forum

Application notes

More information about PNA network analyzer applications can be found at

www.keysight.com/find/pnaapps

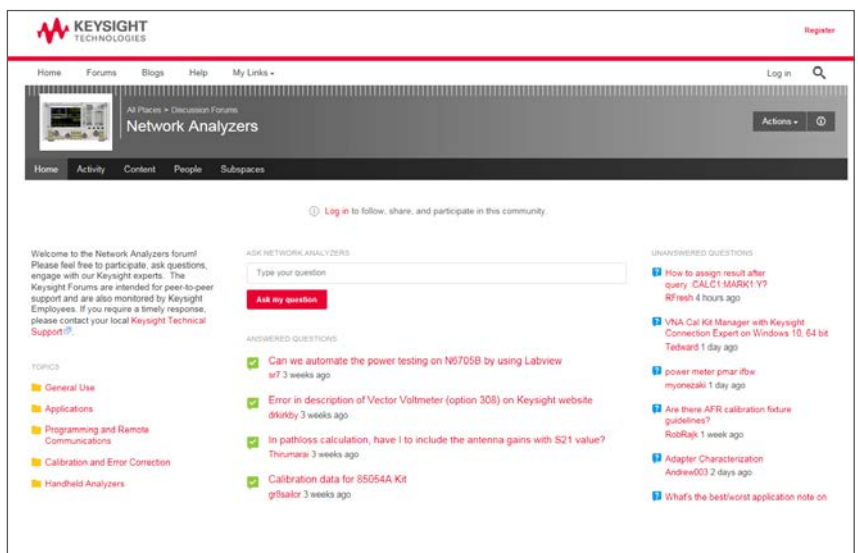

Evolving Since 1939

Our unique combination of hardware, software, services, and people can help you reach your next breakthrough. We are unlocking the future of technology.
 From Hewlett-Packard to Agilent to Keysight.

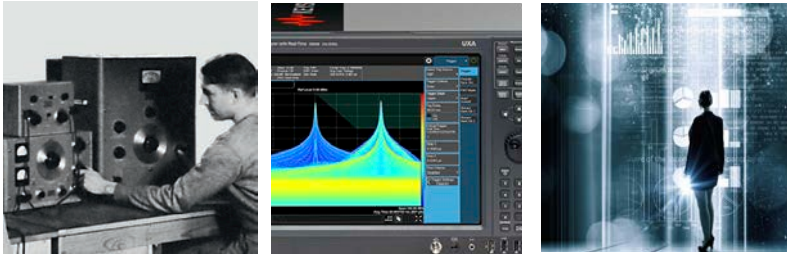

For more information on Keysight Technologies' products, applications or services, please contact your local Keysight office. The complete list is available at: www.keysight.com/find/contactus

Americas

Canada	(877) 894 4414
Brazil	55 11 3351 7010
Mexico	001 800 254 2440
United States	(800) 829 4444

Asia Pacific

Australia	1 800 629 485
China	800 810 0189
Hong Kong	800 938 693
India	1 800 11 2626
Japan	0120 (421) 345
Korea	080 769 0800
Malaysia	1 800 888 848
Singapore	1 800 375 8100
Taiwan	0800 047 866
Other AP Countries	(65) 6375 8100

Europe & Middle East

Austria	0800 001122
Belgium	0800 58580
Finland	0800 523252
France	0805 980333
Germany	0800 6270999
Ireland	1800 832700
Israel	1 809 343051
Italy	800 599100
Luxembourg	+32 800 58580
Netherlands	0800 0233200
Russia	8800 5009286
Spain	800 000154
Sweden	0200 882255
Switzerland	0800 805353
	Opt. 1 (DE)
	Opt. 2 (FR)
	Opt. 3 (IT)
United Kingdom	0800 0260637

For other unlisted countries:

www.keysight.com/find/contactus
 (BP-9-7-17)

DEKRA Certified
ISO 9001 Quality Management System

www.keysight.com/go/quality
 Keysight Technologies, Inc.
 DEKRA Certified ISO 9001:2015
 Quality Management System

myKeysight

myKeysight

www.keysight.com/find/mykeysight

A personalized view into the information most relevant to you.

http://www.keysight.com/find/emt_product_registration

Register your products to get up-to-date product information and find warranty information.

KEYSIGHT SERVICES
 Accelerate Technology Adoption.
 Lower costs.

Keysight Services

www.keysight.com/find/service

Keysight Services can help from acquisition to renewal across your instrument's lifecycle. Our comprehensive service offerings—one-stop calibration, repair, asset management, technology refresh, consulting, training and more—helps you improve product quality and lower costs.

Keysight Assurance Plans

www.keysight.com/find/AssurancePlans

Up to ten years of protection and no budgetary surprises to ensure your instruments are operating to specification, so you can rely on accurate measurements.

Keysight Channel Partners

www.keysight.com/find/channelpartners

Get the best of both worlds: Keysight's measurement expertise and product breadth, combined with channel partner convenience.

www.keysight.com/find/pna

Additional resources can be found at:

- www.keysight.com/find/accessories
- www.keysight.com/find/antenna
- www.keysight.com/find/ecal
- www.keysight.com/find/materials
- www.keysight.com/find/multiport
- www.keysight.com/find/plts
- www.keysight.com/find/pna
- www.keysight.com/find/pulsedrf

