

**Service Guide**  
**E8362C, E8363C, E8364C**  
**Agilent Technologies**  
**PNA Series**  
**Microwave Network Analyzers**



**Agilent Technologies**

**Part Number E8364-90038**

**Printed in USA**

**August 28, 2013**

Supersedes: November 1, 2012

© Agilent Technologies, Inc. 2008-2009, 2011-2013

---

## **WARRANTY STATEMENT**

THE MATERIAL CONTAINED IN THIS DOCUMENT IS PROVIDED “AS IS,” AND IS SUBJECT TO BEING CHANGED, WITHOUT NOTICE, IN FUTURE EDITIONS. FURTHER, TO THE MAXIMUM EXTENT PERMITTED BY APPLICABLE LAW, AGILENT DISCLAIMS ALL WARRANTIES, EITHER EXPRESS OR IMPLIED WITH REGARD TO THIS MANUAL AND ANY INFORMATION CONTAINED HEREIN, INCLUDING BUT NOT LIMITED TO THE IMPLIED WARRANTIES OF MERCHANTABILITY AND FITNESS FOR A PARTICULAR PURPOSE. AGILENT SHALL NOT BE LIABLE FOR ERRORS OR FOR INCIDENTAL OR CONSEQUENTIAL DAMAGES IN CONNECTION WITH THE FURNISHING, USE, OR PERFORMANCE OF THIS DOCUMENT OR ANY INFORMATION CONTAINED HEREIN. SHOULD AGILENT AND THE USER HAVE A SEPARATE WRITTEN AGREEMENT WITH WARRANTY TERMS COVERING THE MATERIAL IN THIS DOCUMENT THAT CONFLICT WITH THESE TERMS, THE WARRANTY TERMS IN THE SEPARATE AGREEMENT WILL CONTROL.

---

## **DFARS/Restricted Rights Notice**

If software is for use in the performance of a U.S. Government prime contract or subcontract, Software is delivered and licensed as “Commercial computer software” as defined in DFAR 252.227-7014 (June 1995), or as a “commercial item” as defined in FAR 2.101(a) or as “Restricted computer software” as defined in FAR 52.227-19 (June 1987) or any equivalent agency regulation or contract clause. Use, duplication or disclosure of Software is subject to Agilent Technologies’ standard commercial license terms, and non-DOD Departments and Agencies of the U.S. Government will receive no greater than Restricted Rights as defined in FAR 52.227-19(c)(1-2) (June 1987). U.S. Government users will receive no greater than Limited Rights as defined in FAR 52.227-14 (June 1987) or DFAR 252.227-7015 (b)(2) (November 1995), as applicable in any technical data.

---

## **Certification**

Agilent Technologies, Inc. certifies that this product met its published specifications at the time of shipment from the factory. Agilent Technologies, Inc. further certifies that its calibration measurements are traceable to the United States National Institute of Standards and Technology, to the extent allowed by the Institute's calibration facility, and to the calibration facilities of other International Standards Organization members.

---

## Assistance

Product maintenance agreements and other customer assistance agreements are available for Agilent Technologies, Inc. products. For information about these agreements and for other assistance, contact Agilent. Refer to [“Contacting Agilent” on page 2-12.](#)

---

## Safety and Regulatory Information

The safety and regulatory information pertaining to this product is located in [Chapter 1, “Safety and Regulatory Information.”](#)

---

## Safety Notes

The following safety notes are used throughout this manual. Familiarize yourself with each of the notes and its meaning before operating this instrument. All pertinent safety notes for using this product are located in [Chapter 1, “Safety and Regulatory Information.”](#)

---

**WARNING**      **Warning denotes a hazard. It calls attention to a procedure which, if not correctly performed or adhered to, could result in injury or loss of life. Do not proceed beyond a warning note until the indicated conditions are fully understood and met.**

---

---

**CAUTION**      Caution denotes a hazard. It calls attention to a procedure that, if not correctly performed or adhered to, could result in damage to or destruction of the instrument. Do not proceed beyond a caution sign until the indicated conditions are fully understood and met.

---

---

## Documentation Map

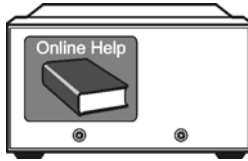

The online Help files are embedded in the analyzer, offering quick reference to programming and user documentation. From the Help drop-down menu, you can access the Help system in five different languages. Also, you can view the Analyzer Product Overview multimedia presentation and access the analyzer's Web page.



The *Installation and Quick Start Guide* helps you to quickly familiarize yourself with the analyzer. Procedures are provided for installing, configuring, and verifying the operation of the analyzer.

---

## Printing Copies of Documentation from the Web

To print copies of documentation from the Web, download the PDF file from the Agilent web site:

- Go to [www.agilent.com](http://www.agilent.com).
- Enter the product model number in the search function and click **Search**.
- Click on the **Manuals** hyperlink.

## 1 Safety and Regulatory Information

Information in This Chapter .....	1-2
Chapter One at-a-Glance .....	1-2
Safety Symbols .....	1-3
General Safety Considerations .....	1-3
Safety Earth Ground .....	1-3
Before Applying Power .....	1-3
Servicing .....	1-4
Electrostatic Discharge Protection .....	1-6
Regulatory Information .....	1-7
Instrument Markings .....	1-8
Lithium Battery Disposal .....	1-9

## 2 General Product Information

Information in This Chapter .....	2-2
Chapter Two at-a-Glance .....	2-2
Maintenance .....	2-3
Physical Maintenance .....	2-3
Electrical Maintenance .....	2-3
Analyzer Options Available .....	2-3
Options as Upgrades .....	2-3
Option 010, Time Domain .....	2-3
Option 014, Configurable Test Set .....	2-3
Option 016, Receiver Attenuators .....	2-4
Options 040 and 041, Extended Frequency Range to 40 GHz .....	2-4
Options 050 and 051, Extended Frequency Range to 50 GHz .....	2-4
Option 067 and 068, Extended Frequency Range to 67 GHz .....	2-4
Option 080, Frequency Offset Mode .....	2-4
Option 081, External Reference Switch .....	2-5
Option 083, Frequency Converter Measurement Application .....	2-5
Option 099, Firmware Upgrade .....	2-5
Option 1CM, Rack Mount Flange Kit for Instruments without Handles .....	2-5
Option 1CP, Rack Mount Flange Kit for Instruments with Handles .....	2-5
Option 897, Built-In Tests for Commercial Calibration .....	2-6
Option 898 Built-In Tests for Standards Compliant Calibration .....	2-6
Option H08, Pulse Measurement Capability .....	2-6
Option H11, IF Access .....	2-6
Option UNL, Source Attenuators and Bias Tees .....	2-6
Analyzer Upgrades Available .....	2-6
Analyzer Accessories Available .....	2-7
CD-RW Drive .....	2-7
USB Hub .....	2-7
Required Service Test Equipment .....	2-8
Agilent Support, Services, and Assistance .....	2-11
Service and Support Options .....	2-11
Contacting Agilent .....	2-12
Shipping Your Analyzer to Agilent for Service or Repair .....	2-12

## 3 Tests and Adjustments

Information in This Chapter	3-2
Chapter Three at-a-Glance	3-2
Before You Begin	3-4
Verify the Operating Environment	3-4
Protect Against Electrostatic Discharge (ESD)	3-4
Allow the Analyzer to Warm Up	3-4
Review the Principles of Connector Care	3-5
About System Verification and Performance Tests	3-6
System Specifications	3-6
Instrument Specifications	3-6
System Verification Procedure	3-7
Performance Tests	3-7
Certificate of Calibration	3-7
ANSI/NCSL Z540–1–1994 Verification	3-8
Non-ANSI/NCSL Z540–1–1994 Verification	3-9
Preliminary Checks	3-10
The Operator’s Check	3-10
The Test Port Cable Checks	3-12
System Verification	3-19
What the System Verification Verifies	3-19
Measurement Uncertainty	3-20
Measurement Traceability	3-21
Performing System Verification	3-22
Option H11, IF Access, Operation Verification	3-29
Performance Tests (Agilent N7840A Software Package)	3-30
Source Power Accuracy Test	3-30
Source Maximum Power Output Test	3-31
Source Power Linearity Test	3-31
Frequency Accuracy Test	3-32
Trace Noise Test	3-32
Receiver Compression Test	3-33
Noise Floor Test	3-34
Calibration Coefficient Test	3-35
System Crosstalk Test	3-36
Dynamic Accuracy Test	3-37
Adjustments	3-38
10 MHz Frequency Reference Adjustment	3-39
3.8 GHz PMYO Frequency Adjustment	3-40
LO Power Adjustment	3-41
LO Offset Adjustment	3-43
Source Calibration Adjustment	3-45
Phase Lock IF Gain Adjustment	3-46
Receiver Calibration Adjustment	3-47

## 4 Troubleshooting

Information in This Chapter	4-2
Chapter Four at-a-Glance	4-2
Protect Against Electrostatic Discharge (ESD)	4-3

Assembly Replacement Sequence . . . . .	4-3
Getting Started with Troubleshooting . . . . .	4-4
Check the Basics . . . . .	4-4
Troubleshooting Organization . . . . .	4-5
Power Up Troubleshooting . . . . .	4-6
Power Supply Check . . . . .	4-7
Front Panel Troubleshooting . . . . .	4-12
Front Panel Keypad and RPG Test . . . . .	4-13
A2 Display Test . . . . .	4-15
Checking the USB Board . . . . .	4-16
A3 Front Panel Interface Board . . . . .	4-16
Rear Panel Troubleshooting . . . . .	4-17
Checking the USB Ports . . . . .	4-17
Checking the SERIAL (RS-232), PARALLEL (1284-C), or VGA Port . . . . .	4-18
Checking the GPIB Port . . . . .	4-18
LAN Troubleshooting . . . . .	4-20
Measurement System Troubleshooting . . . . .	4-24
Before you begin—consider: Where do you see a problem? . . . . .	4-24
Verifying the A, B, R1, and R2 Traces (Standard S-Parameter Mode) . . . . .	4-26
Where to Begin Troubleshooting . . . . .	4-27
Checking the Source Group . . . . .	4-30
Checking the Signal Separation Group . . . . .	4-38
Checking the Receiver Group . . . . .	4-42
Checking the Frequency Offset Group (Option 080) . . . . .	4-44
Instrument Block Diagrams . . . . .	4-49
E8362C Overall Block Diagram, No Options . . . . .	4-49
E8362C Overall Block Diagram, All Options . . . . .	4-51
E8363C and E8364C Overall Block Diagram, No Options . . . . .	4-53
E8363C and E8364C Overall Block Diagram, All Options . . . . .	4-55
<b>5 Theory of Operation</b>	
Information in This Chapter . . . . .	5-2
Chapter Five at-a-Glance . . . . .	5-2
Network Analyzer System Operation . . . . .	5-3
Functional Groups of the Network Analyzer . . . . .	5-3
Source Group Operation . . . . .	5-6
Band Modes . . . . .	5-6
A8 Fractional-N Synthesizer Board . . . . .	5-8
A17 L.O. Multiplier/Amplifier 10 (LOMA 10) . . . . .	5-9
A18 Multiplier/Amplifier 20 (MA 20) . . . . .	5-9
A19 Splitter . . . . .	5-9
A20 L.O. Distribution Assembly (LODA) . . . . .	5-9
A10 Frequency Reference Board . . . . .	5-9
A11 Phase Lock Board . . . . .	5-10
A12 Source 20 . . . . .	5-10
A21 Source Multiplier/Amplifier 50 (SOMA 50) (E8363C and E8364C Only) . . . . .	5-11
A16 Test Set Motherboard . . . . .	5-12
Signal Separation Group Operation . . . . .	5-16
A22 Switch Splitter . . . . .	5-16

A25 and A26 Test Port Couplers	5-17
A23 and A24 Detectors (E8363C and E8364C Only)	5-17
30-dB Fixed Attenuators (E8362C Only)	5-17
A36 and A37 60-dB Source Step Attenuators (Option UNL)	5-18
A38 and A39 Bias Tees (Option UNL)	5-18
A43 and A44 35-dB Receiver Step Attenuators (Option 016)	5-18
Option 014 Configurable Test Set	5-18
Receiver Group Operation	5-21
A27, A28, A29, and A30 Receiver First Converters (Mixers)	5-21
A49 IF Multiplexer Board	5-21
A31, A32, A33, and A34 Receiver Modules	5-21
A6 SPAM Board (Analog Description)	5-23
A35 Receiver Motherboard	5-23
Frequency Offset Group Operation (Options 080 and 081)	5-24
A9 Fractional-N Synthesizer Board (Option 080)	5-24
A13 Frequency Offset Receiver Assembly (Option 080)	5-24
A45 and A46 Reference Transfer Switches (Option 081)	5-24
IF Access Group (Option H11)	5-26
A47 RF Path Coupler	5-26
A48 LO Path Coupler	5-26
A49 IF Multiplexer Board	5-26
Rear-Panel Connections	5-26
Digital Processing and Digital Control Group Operation	5-28
Front Panel Subgroup	5-30
Data Acquisition and Processing Subgroup	5-31
Power Supply Group Operation	5-33
<b>6 Replaceable Parts</b>	
Information in This Chapter	6-2
How to Use the Replaceable Parts Listings in This Chapter	6-2
Chapter Six at-a-Glance	6-2
Ordering Information	6-3
Assembly Replacement Sequence	6-4
Rebuilt-Exchange Assemblies	6-5
Replaceable Parts Listings	6-6
Front Panel Assembly, Front Side, All Options	6-10
Front Panel Assembly, Back Side, All Options	6-12
Top Assemblies, All Options Except 080	6-14
Top Cables—All, All Options Except 080	6-16
Top Assemblies, All Options Including 080	6-18
Top Cables—All, All Options Including 080	6-20
Bottom Assemblies, No Options	6-22
Bottom Semi-Rigid Cables, No Options	6-24
Bottom Assemblies, Option UNL	6-26
Bottom Semi-Rigid Cables, Option UNL	6-28
Bottom Assemblies, Option 014 and Options 014/080	6-30
Bottom Semi-Rigid Cables, Options 014 and 014/080	6-32
Bottom Assemblies, Options UNL/014 and UNL/014/080	6-34
Bottom Semi-Rigid Cables, Options UNL/014 and UNL/014/080	6-36
Bottom Assemblies, Options UNL/016	6-38



Bottom Semi-Rigid Cables, Options UNL/016 .....	6-40
Bottom Assemblies, Options UNL/014/016 and UNL/014/016/080 .....	6-42
Bottom Semi-Rigid Cables, Options UNL/014/016 and UNL/014/016/080 .....	6-44
Bottom Assemblies, Options 014/080/081 .....	6-46
Bottom Semi-Rigid Cables, Options 014/080/081 .....	6-48
Bottom Assemblies, Options UNL/014/080/081 .....	6-50
Bottom Semi-Rigid Cables, Options UNL/014/080/081 .....	6-52
Bottom Assemblies, Options UNL/014/080/081/H11 .....	6-54
Bottom Semi-Rigid Cables, Options UNL/014/080/081/H11 .....	6-56
Bottom Assemblies, Options UNL/014/016/080/081 .....	6-58
Bottom Semi-Rigid Cables, Options UNL/014/016/080/081 .....	6-60
Bottom Assemblies, Options UNL/014/016/080/081/H11 .....	6-62
Bottom Semi-Rigid Cables, Options UNL/014/016/080/081/H11 .....	6-64
Bottom Flexible Cables, All Options .....	6-66
Bottom Ribbon Cables and Wrapped-Wire, All Options .....	6-68
Top Hardware, All Options .....	6-70
Bottom Hardware, All Options .....	6-72
Internal Hardware and Parts, All Options .....	6-74
External Hardware and Parts, All Options .....	6-76
Rear Panel Assembly, All Options .....	6-78
Hard Disk Drive Assembly, All Options .....	6-80
Miscellaneous Part Numbers .....	6-84

## **7 Repair and Replacement Procedures**

Information in This Chapter .....	7-2
Chapter Seven at-a-Glance .....	7-2
Before Starting the Removal and Replacement Procedures .....	7-3
Personal Safety Warnings .....	7-3
Electrostatic Discharge (ESD) Protection .....	7-3
Assembly Replacement Sequence .....	7-3
Removal and Replacement Procedures .....	7-4
Removing the Covers .....	7-6
Raising and Removing the Receiver Deck .....	7-8
Removing and Replacing the Front Panel Assembly .....	7-10
Removing and Replacing Front Panel Subassemblies .....	7-12
Removing and Replacing the A4 Power Supply Assembly .....	7-16
Removing and Replacing the A6, A8, A9, and A10 Boards .....	7-18
Removing and Replacing the A11 Phase Lock Board .....	7-20
Removing and Replacing the A12 Source 20 .....	7-22
Removing and Replacing the A13 Frequency Offset Receiver Assembly .....	7-24
Removing and Replacing the A14 System Motherboard .....	7-26
Removing and Replacing the A15 CPU Board .....	7-28
Removing and Replacing the A16 Test Set Motherboard .....	7-32
Removing and Replacing the A17 LOMA 10 .....	7-34
Removing and Replacing the A18 MA 20 .....	7-36
Removing and Replacing the A19 Splitter .....	7-38
Removing and Replacing the A20 LODA .....	7-40
Removing and Replacing the A21 SOMA 50 (E8363C and E8364C Only) .....	7-42
Removing and Replacing the A22 Switch Splitter .....	7-44

Removing and Replacing the 30-dB Fixed Attenuators (E8362C only) . . . . .	7-46
Removing and Replacing the A23 and A24 Detectors (E8363C and E8364C only) . . . . .	7-48
Removing and Replacing the A25 and A26 Test Port Couplers . . . . .	7-50
Removing and Replacing the A27, A28, A29, and A30 First Converters (Mixers) and Mixer Bias Board . . . . .	7-52
Removing and Replacing the A31, A32, A33, and A34 Receiver Modules and A49 IF Multiplexer Board . . . . .	7-54
Removing and Replacing the A35 Receiver Motherboard . . . . .	7-56
Removing and Replacing the A36 and A37 60-dB Source Step Attenuators (Option UNL) . . . . .	7-58
Removing and Replacing the A38 and A39 Bias Tees (Option UNL) . . . . .	7-60
Removing and Replacing the A41 Hard Disk Drive (HDD) . . . . .	7-62
Removing and Replacing the A43 and A44 35-dB Receiver Step Attenuators (Option 016) . . . . .	7-70
Removing and Replacing the A45 and A46 Reference Channel Transfer Switches (Option 081) . . . . .	7-72
Removing and Replacing the A47 and A48 Couplers (Option H11) . . . . .	7-74
Removing and Replacing the Midweb and the B1 Fan . . . . .	7-76
Removing and Replacing the USB Hub . . . . .	7-79
Removing and Replacing the Lithium Battery . . . . .	7-80
Post-Repair Procedures . . . . .	7-82
<b>8 General Purpose Maintenance Procedures</b>	
Information in This Chapter . . . . .	8-2
Chapter Eight at-a-Glance . . . . .	8-2
Error Terms . . . . .	8-3
Using Error Terms as a Diagnostic Tool . . . . .	8-3
Performing Measurement Calibration . . . . .	8-4
Using Flowgraphs to Identify Error Terms . . . . .	8-4
Accessing Error Terms . . . . .	8-8
Error Term Data . . . . .	8-10
Option Enable Utility . . . . .	8-15
Accessing the Option Enable Utility . . . . .	8-15
Enabling or Removing Options . . . . .	8-16
Repairing and Recovering Option Data . . . . .	8-17
Installing or Changing a Serial Number . . . . .	8-18
Firmware Upgrades . . . . .	8-19
How to Check the Current Firmware Version . . . . .	8-19
Downloading from the Internet . . . . .	8-19
Operating System Recovery . . . . .	8-20
Recovering from Hard Disk Drive Problems . . . . .	8-20
Correction Constants . . . . .	8-21
Storing Correction Constants . . . . .	8-21

---

# **1 Safety and Regulatory Information**

---

## Information in This Chapter

This chapter provides safety information that will help protect you and your network analyzer. It also contains information that is required by various government regulatory agencies.

### Chapter One at-a-Glance

Section Title	Summary of Content	Start Page
<a href="#">Safety Symbols</a>	Descriptions of <b>CAUTION</b> and <b>WARNING</b> symbols used throughout this manual.	<a href="#">Page 1-3</a>
<a href="#">General Safety Considerations</a>	A list of safety points to consider when servicing your network analyzer.	<a href="#">Page 1-3</a>
<a href="#">Electrostatic Discharge Protection</a>	A discussion of electrostatic discharge (ESD) and related recommendations and requirements for ESD protection.	<a href="#">Page 1-6</a>
<a href="#">Regulatory Information</a>	Definitions of instrument markings. Instructions for disposing of the analyzer's lithium battery.	<a href="#">Page 1-7</a>

---

## Safety Symbols

The following safety symbols are used throughout this manual. Familiarize yourself with each of the symbols and its meaning before operating this instrument.

---

**CAUTION** Caution denotes a hazard. It calls attention to a procedure that, if not correctly performed or adhered to, could result in damage to or destruction of the instrument. Do not proceed beyond a caution note until the indicated conditions are fully understood and met.

---

---

**WARNING** Warning denotes a hazard. It calls attention to a procedure which, if not correctly performed or adhered to, could result in injury or loss of life. Do not proceed beyond a warning note until the indicated conditions are fully understood and met.

---

---

## General Safety Considerations

### Safety Earth Ground

---

**WARNING** This is a Safety Class I product (provided with a protective earthing ground incorporated in the power cord). The mains plug shall only be inserted in a socket outlet provided with a protective earth contact. Any interruption of the protective conductor, inside or outside of the instrument, will make the instrument dangerous. Intentional interruption is prohibited.

---

---

**CAUTION** Always use the three-prong AC power cord supplied with this product. Failure to ensure adequate grounding by not using this cord may cause product damage.

---

### Before Applying Power

---

**WARNING** If this product is not used as specified, the protection provided by the equipment could be impaired. This product must be used in a normal condition (in which all means for protection are intact) only.

---

---

**WARNING** If an instrument handle is damaged, you should replace it immediately. Damaged handles can break while you are moving or lifting the instrument and cause personal injury or damage to the instrument.

---

---

**CAUTION** This instrument has autoranging line voltage input. Be sure the supply voltage is within the specified range.

---

---

**CAUTION** This product is designed for use in Installation Category II and Pollution Degree 2 per IEC

---

61010-1:2001 and 664 respectively.

---

**CAUTION**     **Ventilation Requirements:** When installing the product in a cabinet, the convection into and out of the product must not be restricted. The ambient temperature (outside the cabinet) must be less than the maximum operating temperature of the instrument by 4 °C for every 100 watts dissipated in the cabinet. If the total power dissipated in the cabinet is greater than 800 watts, then forced convection must be used.

---

**CAUTION**     The measuring terminals on this instrument are designed to be used with external signals described in Measurement Category I, but NOT with external signals described in Categories II, III, and IV. The input of this instrument cannot be connected to the mains.

---

## Servicing

---

**WARNING**     **These servicing instructions are for use by qualified personnel only. To avoid electrical shock, do not perform any servicing unless you are qualified to do so.**

---

**WARNING**     **Danger of explosion if battery is incorrectly replaced. Replace only with the same or equivalent type recommended. Discard used batteries according to local ordinances and/or manufacturer's instructions.**

---

**WARNING**     **Procedures described in this document may be performed with power supplied to the product while protective covers are removed. Energy available at many points may, if contacted, result in personal injury.**

---

**WARNING**     **No operator serviceable parts inside. Refer servicing to qualified personnel. To prevent electrical shock, do not remove covers.**

---

**WARNING**     **The opening of covers or removal of parts may expose dangerous voltages. Disconnect the instrument from all voltage sources while it is being opened.**

---

---

**WARNING** For continued protection against fire hazard, replace line fuse only with same type and rating. The use of other fuses or material is prohibited.

---

**WARNING** The detachable power cord is the instrument disconnecting device. It disconnects the mains circuits from the mains supply before other parts of the instrument. The front panel switch is only a standby switch and is not a LINE switch (disconnecting device).

---

## Electrostatic Discharge Protection

Protection against electrostatic discharge (ESD) is essential while removing assemblies from or connecting cables to the network analyzer. Static electricity can build up on your body and can easily damage sensitive internal circuit elements when discharged. Static discharges too small to be felt can cause permanent damage. To prevent damage to the instrument:

- *always* have a grounded, conductive table mat in front of your test equipment.
- *always* wear a grounded wrist strap, connected to a grounded conductive table mat, having a 1 M $\Omega$  resistor in series with it, when handling components and assemblies or when making connections.
- *always* wear a heel strap when working in an area with a conductive floor. If you are uncertain about the conductivity of your floor, wear a heel strap.
- *always* ground yourself before you clean, inspect, or make a connection to a static-sensitive device or test port. You can, for example, grasp the grounded outer shell of the test port or cable connector briefly.
- *always* ground the center conductor of a test cable before making a connection to the analyzer test port or other static-sensitive device. This can be done as follows:
  1. Connect a short (from your calibration kit) to one end of the cable to short the center conductor to the outer conductor.
  2. While wearing a grounded wrist strap, grasp the outer shell of the cable connector.
  3. Connect the other end of the cable to the test port and remove the short from the cable.

Figure 1-1 shows a typical ESD protection setup using a grounded mat and wrist strap. Refer to “ESD Supplies” on page 6-86 for part numbers.

Figure 1-1 ESD Protection Setup

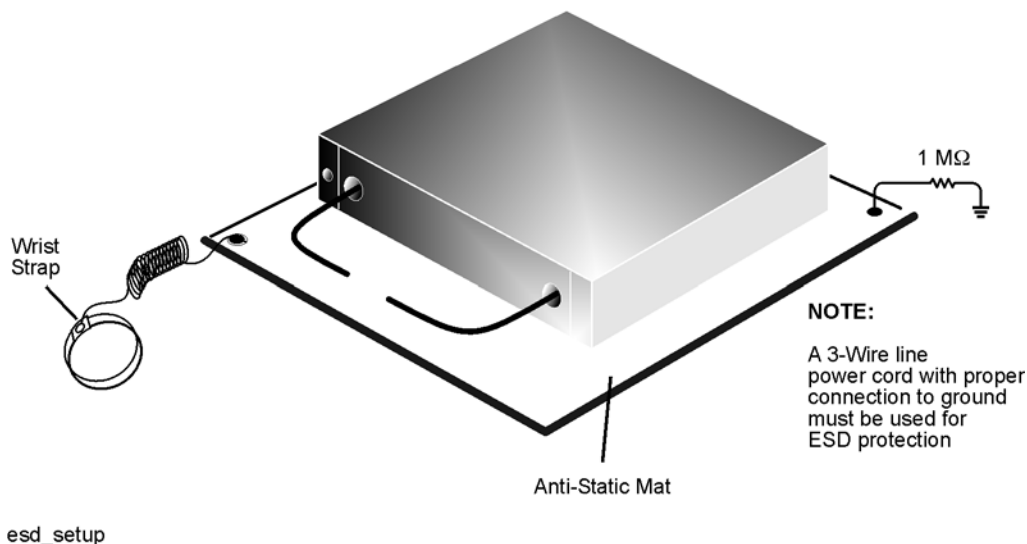



---

## Regulatory Information

This section contains information that is required by various government regulatory agencies.

## Instrument Markings



The instruction documentation symbol. The product is marked with this symbol when it is necessary for the user to refer to the instructions in the documentation.



The CE mark is a registered trademark of the European Community. (If accompanied by a year, it is when the design was proven.)



The CSA mark is a registered trademark of the Canadian Standards Association.

ICES/NMB-001

This is a marking to indicate product compliance with the Canadian Interference-Causing Equipment Standard (ICES-001).

ISM1-A

This is a symbol of an Industrial Scientific and Medical Group 1 Class A product.



This is a required mark signifying compliance with an EMC requirement. The C-Tick mark is a registered trademark of the Australian Spectrum Management Agency.



This product complies with the WEEE Directive (2002/96/EC) marking requirements. The affixed label indicates that you must not discard this electrical/ electronic product in domestic household waste.

*Product Category: With reference to the equipment types in the WEEE Directive Annex I, this product is classed as a "Monitoring and Control instrumentation" product.*

**Do not dispose in domestic household waste.**

**To return unwanted products, contact your local Agilent office, or see <http://www.agilent.com/environment/product/> for more information.**



This product complies with the China RoHS regulation. A paper is included with the shipment that has a *Toxic Substance Table* showing the hazardous substances in the product.



This symbol indicates compliance with China RoHS regulations for paper/fiberboard packaging.



KCC-REM-ATi-  
XXXXXXXXXX

Korean Certification (KC) mark. Must include the marking's identifier code (Agilent product specific) as follows:  
KCC-REM-ATi- WNaNALYZERF01

## Lithium Battery Disposal

If the battery on the A15 CPU board assembly needs to be disposed of, dispose of it in accordance with your country's requirements. If required, you may return the battery to Agilent Technologies for disposal. Refer to ["Contacting Agilent" on page 2-12](#) for assistance.



**DO NOT THROW BATTERIES AWAY BUT  
COLLECT AS SMALL CHEMICAL WASTE.**

For instructions on removing and replacing the battery on the A15 CPU board assembly, refer to ["Removing and Replacing the Lithium Battery" on page 7-80](#).



---

## **2 General Product Information**

---

## Information in This Chapter

### Chapter Two at-a-Glance

Section Title	Summary of Content	Start Page
<a href="#">Maintenance</a>	Cleaning instructions for the external surfaces of your analyzer. Information about electrical maintenance of your analyzer.	<a href="#">Page 2-3</a>
<a href="#">Analyzer Options Available</a>	A list of the options available for the microwave PNA.	<a href="#">Page 2-3</a>
<a href="#">Analyzer Upgrades Available</a>	A list of the upgrades available for the microwave PNA.	<a href="#">Page 2-6</a>
<a href="#">Analyzer Accessories Available</a>	A list of accessories available for the microwave PNA.	<a href="#">Page 2-7</a>
<a href="#">Required Service Test Equipment</a>	A list of service equipment that is required to perform system verification, performance tests, adjustments, and troubleshooting.	<a href="#">Page 2-8</a>
<a href="#">Agilent Support, Services, and Assistance</a>	The Internet address (URL) for on-line assistance. Telephone and fax numbers for contacting Agilent for assistance. Service and support options available. Calibration options available. Important information about shipping your analyzer to Agilent for service or repair.	<a href="#">Page 2-11</a>

---

## Maintenance

---

**WARNING** To prevent electrical shock, disconnect the analyzer from the mains source before cleaning. Use a dry cloth or one slightly dampened with water to clean the external case parts. Do not attempt to clean internally.

---

### Physical Maintenance

Clean the cabinet, including the front panel, using a dry or slightly damp cloth only.

### Electrical Maintenance

Refer to [“Review the Principles of Connector Care”](#) on page 3-5.

---

## Analyzer Options Available

### Options as Upgrades

The options described in this section can be ordered as upgrades. Refer to [“Analyzer Upgrades Available”](#) on page 2-6.

Individual upgrade kits are also available and can be ordered by part number. Refer to [“E8362C Upgrade Kits”](#) on page 6-85 and [“E8363C, E8364C Upgrade Kits”](#) on page 6-85 for a complete list of available kits.

### Option 010, Time Domain

An Option 010 analyzer can display the time domain response of a network or test device by calculating the inverse Fourier transform of the frequency domain response. This calculation allows the Option 010 analyzer to show the response of a test device as a function of time or distance. In time domain, the magnitude and location of a discontinuity and the characteristics of individual transmission paths of a network or test device can be determined. Time domain operation retains all the accuracy of active error correction.

### Option 014, Configurable Test Set

An Option 014 analyzer can be configured to measure high-power devices and devices for high dynamic range.

For a high-power measurement, external amplifiers and high power attenuators or isolators can be added to complete the test setup. Test port output power up to 1 Watt (+30 dBm) can be applied to the device under test (DUT). Additionally, there is an external reference input that allows the external amplifier's frequency response and drift to be ratioed out.

For high dynamic range measurements, front panel jumpers are moved to reverse the signal path through one of the couplers, allowing for a 15 dB improvement in transmitted signal sensitivity in one direction only. Jumpers are installed on both ports allowing the user to choose a measurement in either the forward or reverse direction.

## Option 016, Receiver Attenuators

This upgrade provides a 35-dB step attenuator, in 5-dB steps, in the A and B receiver channels.

## Options 040 and 041, Extended Frequency Range to 40 GHz

This upgrade—E8362CU-040—provides the additional hardware and software necessary to make frequency measurements up to 40 GHz with your E8362C PNA.

If you have a standard E8362C PNA, then upgrade E8362CU-040 provides the additional hardware and software necessary to make frequency measurements up to 40 GHz.

If your E8362C PNA already has option 014, then option E8362CU-041 provides additional hardware and software necessary to make frequency measurements up to 40 GHz, and upgrades your 3.5 mm connectors to 2.4 mm connectors.

## Options 050 and 051, Extended Frequency Range to 50 GHz

This upgrade provides the additional hardware and software necessary to make frequency measurements up to 50 GHz with your E8362C/63B PNA.

If you have a standard E8362C PNA, then upgrade E8362CU-050 provides the additional hardware and software necessary to make frequency measurements up to 50 GHz.

If your E8362C PNA already has option 014, then option E8362CU-051 provides additional hardware and software necessary to make frequency measurements up to 50 GHz, and upgrades your 3.5 mm connectors to 2.4 mm connectors.

If you have a E8363C PNA—with or without option 014—then upgrade E8363CU-050 provides the additional hardware and software necessary to make frequency measurements up to 50 GHz.

## Option 067 and 068<sup>1</sup>, Extended Frequency Range to 67 GHz

These upgrades provide the additional hardware and software necessary to make frequency measurements up to 67 GHz with your E8363C/64B PNA. Option 067 is for analyzers without Option 014 and Option 068 is for analyzers with Option 014 already installed.

## Option 080, Frequency Offset Mode

This upgrade provides the additional hardware and software necessary to make frequency offset measurements. This option requires that Option 081 also be installed.

## Option 081, External Reference Switch

This upgrade adds a solid-state internal RF transfer switch in the R1 reference receiver path. The switch allows the instrument to easily switch between standard S-parameter (non-frequency offset) measurements and frequency offset measurements such as relative phase or absolute group delay that require an external reference mixer. The user can set the switch manually or remotely, but it is best used with the frequency-converter application (option 083), where it is controlled automatically during the vector-mixer calibration procedure.

---

1. These upgrades are not available for the E8362C PNA.



### **Option 083, Frequency Converter Measurement Application**

This option adds an intuitive and easy-to-use user interface, advanced calibration choices that provide exceptional amplitude and phase accuracy, and control of external signal sources for use as local oscillators (both fixed and swept-LO measurements are supported). A graphical set-up dialog box lets you quickly set up the instrument for single or dual conversion devices. This set-up screen also helps you calculate and choose where mixing and image products will fall.

### **Option 099, Firmware Upgrade**

This upgrade provides the latest revision of firmware for the PNA series network analyzers on CD-ROM. This firmware is user installable. The installation requires a USB CD-ROM drive (see “CD-RW Drive” on page 2-7) or an external computer connected to a Local Area Network (LAN).

This firmware is also available on the Internet at the Agilent website: <http://www.agilent.com/find/pna>. (Select your analyzer’s model number in this website to view available upgrades.)

### **Option 1CM, Rack Mount Flange Kit for Instruments without Handles**

Option 1CM provides a rack mount kit that contains a pair of flanges, rack mount rails, and the necessary hardware to mount the analyzer in an equipment rack with 482.6 mm (19 inches) horizontal spacing.

Additional kits may be ordered from Agilent. Refer to “Rack Mount Kits and Handle Kits” on page 6-86 for the part numbers.

### **Option 1CP, Rack Mount Flange Kit for Instruments with Handles**

Option 1CP provides a rack mount kit that contains a pair of flanges (cut to adapt to handles), rack mount rails, and the necessary hardware to mount the analyzer in an equipment rack with 482.6 mm (19 inches) horizontal spacing.

Additional kits may be ordered from Agilent. Refer to “Rack Mount Kits and Handle Kits” on page 6-86 for the part numbers.

### **Option 897, Built-In Tests for Commercial Calibration**

This option enables performance tests that are built into the analyzer that enable you to perform ISO 9001 commercial calibration of your analyzer. Refer to “Service and Support Options” on page 2-11 for a description of the commercial calibration.

### **Option 898 Built-In Tests for Standards Compliant Calibration**

This option enables performance tests that are built into the analyzer that enable you to perform ISO 17025 and ANSI Z540 standards compliant calibration of your analyzer. Refer to “Service and Support Options” on page 2-11 for a description of the standards compliant calibrations.

### **Option H08, Pulse Measurement Capability**

This option enables additional firmware and hardware within the analyzer to allow you to perform pulse measurements with you PNA. This option requires that Option H11 also be installed.

## Option H11, IF Access

This option adds additional hardware to your PNA that allows for external connection to the internal IF path of the PNA. This option requires that Options 014, 080, 081, and UNL also be installed.

## Option UNL, Source Attenuators and Bias Tees

This option adds a 60-dB step attenuator and a bias tee between the switch splitter and each of the ports. The step attenuators are used to adjust the power level to the device under test (DUT) without changing the power in the reference path. The bias tees provide a means of biasing active devices under test. DC bias for the bias tees is provided through two rear-panel BNC connectors. These inputs are fused for protection.

---

## Analyzer Upgrades Available

The options described in this section can be ordered as upgrades. To order an upgrade for your microwave PNA, order the analyzer's model number, followed by a "U", then indicate the option to be added:

- Your analyzer's current model number followed by a "U". For example, E8364CU.
  - The number of the desired option from the available list. For example, the Time Domain option would be E8364CU-010.

The following table lists the upgrades that are available for your PNA. Refer to the previous section, ["Analyzer Options Available" on page 2-3](#), for a complete description of each option upgrade.

**Table 2-1 Analyzer Upgrades Available**

Upgrade	Order Number <sup>a</sup>
Time domain (Option 010)	E8362/3/4CU-010
Configurable test set (Option 014)	E8362/3/4CU-014
Receiver attenuators (Option 016)	E8362/3/4CU-016
Extended frequency range to 40 GHz for E8362C without Option 014 (Option 040)	E8362CU-040
Extended frequency range to 40 GHz for E8362C with Option 014 (Option 041)	E8362CU-041
Extended frequency range to 50 GHz for E8362C without Option 014 (Option 050)	E8362CU-050
Extended frequency range to 50 GHz for E8363C with or without Option 014 (Option 050)	E8363CU-050
Extended frequency range to 50 GHz for E8362C with Option 014 (Option 051)	E8362CU-051
Extended frequency range to 67 GHz for E8363/4C without Option 014 (Option 067)	E8363/4CU-067
Extended frequency range to 67 GHz for E8363/4C with Option 014 (Option 068)	E8363/4CU-068
Frequency offset mode (Option 080)	E8362/3/4CU-080
Reference mixer transfer switches (Option 081)	E8362/3/4CU-081
Mixer measurement application (Option 083)	E8362/3/4CU-083
Firmware upgrade on CD-ROM (Option 099)	E8362/3/4CU-099
Add built-in performance test software for Agilent inclusive calibration perpetual license (Option897)	E8362/3/4CU-897
Add built-in performance test software for standards compliant calibration perpetual license (Option898)	E8362/3/4CU-898
Pulse measurement capability (Option H08)	E8362/3/4CU-H08
IF access (Option H11)	E8362/3/4CU-H11
Source attenuators and bias tees (Option UNL)	E8362/3/4CU-UNL

a. E8362/3/4C is used to represent a range of model numbers and should be replaced with one of the following, as appropriate: E8362C, E8363C, or E8364C

---

## Analyzer Accessories Available

### CD-RW Drive

This accessory is an external read/write CD drive with a USB cable and can be ordered as model number N4688A.

### USB Hub

This accessory is a 4-port USB hub for connecting additional USB peripheral devices and can be ordered as model number N4689A.

## Required Service Test Equipment

Equipment <sup>a</sup>	Critical Specifications	Recommended Model or Part Number	Alternate Model or Part Number	Use <sup>b</sup>
<b>Test Instruments and Software</b>				
Frequency counter	Freq: 10 MHz to 20 GHz Accuracy : ±0.5 ppm	53151A Opt 001	None	P, A,T
Spectrum analyzer	Min Freq: 1 MHz Max Freq: > 4 GHz Resolution BW: 300 Hz	8565E	856xE	A,T
Power meter	Accuracy: ±0.0068 dB	E4418B/19B	E4418A/19A <sup>c</sup>	P, A,T
Power sensor (All)	Freq: 10 MHz to 4.2 GHz Range: -30 to +20 dBm	8482A	None	P, A,T
Power sensor (E8362C)	Freq: 50 MHz to 20 GHz Range: -30 to +20 dBm	E4413A	None	P, A,T
Power sensor (E8363C, E8364C)	Freq: 50 MHz to 40 or 50 GHz Range: -30 to +20 dBm	8487A	None	P, A,T
Dynamic accuracy test set	None specified	Z5623A Opt H01	None	P
Compression test set	None specified	Z5623A Opt K01	None	P
Digital voltmeter	Resolution: 10 mV	Any	Any	T
Printer	N/A	Any printer with Microsoft Windows 2000 driver		P
Test software <sup>d</sup>	N/A	N7840A	None	P

- a. Unless specified otherwise, equipment listed is required for all analyzer models.  
 b. P = Performance tests, A = Adjustments, T = Troubleshooting, V = System verification  
 c. If an accurate measurement of the dynamic accuracy specification is not required, the E4418A or E4419A can be used.  
 d. The recommended model or part number for all equipment listed with a "P" in the Use column is required for proper operation of this test software.

Equipment <sup>a</sup>	Critical Specifications	Recommended Model or Part Number	Alternate Model or Part Number	Use <sup>b</sup>
<b>Calibration and Verification Kits</b>				
Type-N calibration kit (E8362C)	--	85054B DC to 18 GHz	85054D DC to 18 GHz	P,T
Type-N verification kit (E8362C)	--	85055A 300 kHz to 18 GHz	None	V
3.5 mm calibration kit (E8362C, E8363C, E8364C)	--	85052B DC to 26.5 GHz	85052D DC to 26.5 GHz	P,T
3.5 mm verification kit (E8362C, E8363C, E8364C)	--	85053B 300 kHz to 26.5 GHz	None	V
2.4 mm calibration kit (E8363C, E8364C)	--	85056A DC to 50 GHz	85056D DC to 50 GHz	P,T
2.4 mm verification kit (E8363C, E8364C)	--	85057B 45 MHz to 50 GHz	None	V
<b>Cables</b>				
BNC cable (2 required)	50Ω, length ≥ 60 cm	8120-1839	None	A
3.5 mm RF cable (Qty 2) (E8362C)	50Ω, length ≥ 60 cm	85131C	85131E	P,A,V
2.4 mm RF cable (Qty 2) (E8363C, E8364C)	50Ω, length ≥ 60 cm	85133C	85133E	P,A,V
GPIB cable	N/A	10833A/B/C/D	None	P,A
<b>Adapters</b>				
3.5 mm (f) to 3.5 mm (f) (E8362C)	Return Loss: ≥ 32 dB	83059B	85052-60012 <sup>c</sup>	P,A,T
3.5 mm (f) to type-N (m) (E8362C)	Return Loss: ≥ 28 dB	1250-1743	None	P,A,T
2.4 mm (f) to 2.4 mm (f) (E8363C, E8364C)	Return Loss: ≥ 26 dB	11900B	85056-60007 <sup>d</sup>	P,A,T
2.4 mm (f) to type-N (m) (E8363C, E8364C)	Return Loss: ≥ 28 dB	11903D	None	P,A,T
<b>Attenuators</b>				
3.5 mm (m,f), 10-dB fixed attenuator (E8362C)	Accuracy: ± 0.5 dB Freq: 10 MHz to 20 GHz	8493C Option 010	None	P
3.5 mm (m,f), 20-dB fixed attenuator (E8362C)	Accuracy: ± 0.5 dB Freq: 10 MHz to 20 GHz	8493C Option 020	None	P
2.4 mm (m,f), 10-dB fixed attenuator (E8363C, E8364C)	Accuracy: ± 0.5 dB Freq: 10 MHz to 40 or 50 GHz	8490D Option 010	None	P
2.4 mm (m,f), 20-dB fixed attenuator (E8363C, E8364C)	Accuracy: ± 0.5 dB Freq: 10 MHz to 40 or 50 GHz	8490D Option 020	None	P

- a. Unless specified otherwise, equipment listed is required for all analyzer models.  
b. P = Performance tests, A = Adjustments, T = Troubleshooting, R = Repair, V = System verification  
c. Included in the 85052B/D calibration kits.  
d. Included in the 85056A/D calibration kits.

Equipment <sup>a</sup>	Critical Specifications	Recommended Model or Part Number	Alternate Model Number	Use <sup>b</sup>
<b>Tools</b>				
Extender board	N/A	E8356-60021	None	T
T-8 TORX driver	0.6 N-m (5 in-lb) setting	N/A	N/A	R
T-10 TORX driver	0.5, 0.8, and 1.0 N-m (4, 7, and 9 in-lb) settings	N/A	N/A	T,R
T-20 TORX driver	2.4 N-m (21 in-lb) setting	N/A	N/A	T,R
1/4-inch and 5/16-inch open-end wrench	Thin profile	8710-0510	N/A	A,R
5/16-inch, open-end torque wrench	1.1 and 2.4 N-m (10 and 21 in-lb) settings (for semi-rigid cables)	N/A	N/A	T,R
1-inch, open-end torque wrench	8.1 N-m (72 in-lb) setting (for Port 1 and Port 2 connector nuts)	N/A	N/A	R
20-mm, open-end torque wrench	0.9 N-m (8 in-lb) setting (for Port 1 and Port 2 measurement connections)	N/A	N/A	R
<b>Static Safety Parts</b>				
Adjustable antistatic wrist strap	N/A	9300-1367	None	P,A,T
Antistatic wrist strap grounding cord (5 foot)	N/A	9300-0980	None	P,A,T
Static control table mat and earth ground wire	N/A	9300-0797	None	P,A,T
<b>Miscellaneous</b>				
USB flash ROM drive	N/A	Any	None	P,A,R

- a. Unless specified otherwise, equipment listed is required for all analyzer models.  
b. P = Performance tests, A = Adjustments, T = Troubleshooting, R = Repair, V = System verification

---

## Agilent Support, Services, and Assistance

Information on the following topics is included in this section.

- “Service and Support Options”
- “Contacting Agilent”
- “Shipping Your Analyzer to Agilent for Service or Repair”

### Service and Support Options

The analyzer’s standard warranty period is *one-year from the time of initial delivery*. All repairs require the analyzer to be shipped to the nearest Agilent Technologies service center. Extended warranty periods can be purchased with the initial product purchase.

There are many other repair and calibration options available from the Agilent Technologies support organization. These options cover a range of service agreements with a variety of time frames. The following support products with their associated options are available for purchase with the initial product purchase.

- R1280A Return to Agilent Warranty and Service Plan  
Options are available to extend the warranty period to three or five years.
- R1282A Return to Agilent Calibration Plan  
The analyzer is delivered with a one-year calibration certificate. Options are available to have Agilent Technologies provide three or five year calibration coverage (perform the annual calibration two or four times). Options for basic calibration or ISO 17025 or ANSI Z540 standards compliant calibrations are available. After calibration, the analyzer will be returned with a calibration label, a calibration certificate, and the calibration data.
- R1288A Return to Agilent On-Site Warranty and Service Plan  
Same as R1280A, but the service is provided at the customer site.
- R1298A Return to Agilent On-Site Calibration Plan  
Same as R1282A, but the service is provided at the customer site.

For more information on these and other service, please visit <http://service.tm.agilent.com/infoline/> or refer to “Contacting Agilent” on page 2-12. If the warranty or calibration plan period has expired, these services are available on a per-incident basis. Visit this InfoLine web site or contact Agilent to obtain a quote.

## Contacting Agilent

Assistance with test and measurements needs and information on finding a local Agilent office are available on the Web at:

<http://www.agilent.com/find/assist>

If you do not have access to the Internet, please contact your Agilent field engineer.

---

**NOTE** In any correspondence or telephone conversation, refer to the Agilent product by its model number and full serial number. With this information, the Agilent representative can determine whether your product is still within its warranty period.

---

## Shipping Your Analyzer to Agilent for Service or Repair

---

**IMPORTANT** Agilent Technologies reserves the right to reformat or replace the internal hard disk drive in your analyzer as part of its repair. This will erase all user information stored on the hard disk. It is imperative, therefore, that you make a backup copy of your critical test data located on the analyzer's hard disk before shipping it to Agilent for repair.

---

If you wish to send your network analyzer to Agilent Technologies for service or repair:

- Include a complete description of the service requested or of the failure and a description of any failed test and any error message.
- Remove and retain all rack mount hardware and front handles. The analyzer should be sent to Agilent in the same configuration it was originally shipped.
- Ship the analyzer using the original or comparable antistatic packaging materials.
- Contact Agilent for instructions on where to ship your analyzer. Refer to ["Contacting Agilent" on page 2-12](#).



---

## **3 Tests and Adjustments**

## Information in This Chapter

This chapter contains procedures to help you check, verify, and adjust your PNA series network analyzer.

- The checks verify the operation of the assemblies in your analyzer.
- The verification compares the operation of your analyzer to a gold standard.
- The adjustments allow you to tune your analyzer for maximum response.

**NOTE** A description of the performance tests in the Agilent N7840A software package is included in this chapter. The Agilent N7840A software package must be purchased separately.

## Chapter Three at-a-Glance

Section Title	Summary of Content	Start Page
Before You Begin	Items to consider or procedures to perform before testing is begun: <ul style="list-style-type: none"> <li>• <a href="#">Verify the Operating Environment</a></li> <li>• <a href="#">Protect Against Electrostatic Discharge (ESD)</a></li> <li>• <a href="#">Allow the Analyzer to Warm Up</a></li> <li>• <a href="#">Review the Principles of Connector Care</a></li> </ul>	Page 3-4
About System Verification and Performance Tests	Descriptions of: <ul style="list-style-type: none"> <li>• <a href="#">System Specifications</a></li> <li>• <a href="#">Instrument Specifications</a></li> <li>• <a href="#">System Verification Procedure</a></li> <li>• <a href="#">Performance Tests</a></li> <li>• <a href="#">Certificate of Calibration</a></li> </ul>	Page 3-6
ANSI/NCSL Z540–1–1994 Verification	The ANSI/NCSL Z540-1-1994 process of verifying your analyzer.	Page 3-8
Non-ANSI/NCSL Z540–1–1994 Verification	The non-ANSI/NCSL Z540-1-1994 process of verifying your analyzer.	Page 3-9
Preliminary Checks	Performing the operator’s check. Checking your test cables. <i>Perform these checks before performing system verification.</i>	Page 3-10
System Verification	What the system verification does. How to perform the verification test. How to interpret the results.	Page 3-19

<b>Section Title</b>	<b>Summary of Content</b>	<b>Start Page</b>
<a href="#">Option H11, IF Access, Operation Verification</a>	How to verify the operation of Option H11, IF access.	<a href="#">Page 3-29</a>
<a href="#">Performance Tests (Agilent N7840A Software Package)<sup>a</sup></a>	A brief summary of each performance test in the Agilent N7840A software package: <ul style="list-style-type: none"> <li>• <a href="#">Source Power Accuracy Test</a></li> <li>• <a href="#">Source Power Linearity Test</a></li> <li>• <a href="#">Frequency Accuracy Test</a></li> <li>• <a href="#">Trace Noise Test</a></li> <li>• <a href="#">Receiver Compression Test</a></li> <li>• <a href="#">Noise Floor Test</a></li> <li>• <a href="#">Calibration Coefficient Test</a></li> <li>• <a href="#">System Crosstalk Test</a></li> <li>• <a href="#">Dynamic Accuracy Test</a></li> </ul>	<a href="#">Page 3-30</a>
<a href="#">Adjustments</a>	Setups and procedures for adjusting your analyzer: <ul style="list-style-type: none"> <li>• <a href="#">Source Calibration Adjustment</a></li> <li>• <a href="#">Receiver Calibration Adjustment</a></li> <li>• <a href="#">LO Power Adjustment</a></li> <li>• <a href="#">10 MHz Frequency Reference Adjustment</a></li> <li>• <a href="#">3.8 GHz PMYO Frequency Adjustment</a></li> </ul>	<a href="#">Page 3-38</a>

a. The Agilent N7840A software package must be purchased separately.

---

## Before You Begin

Before checking, verifying, or adjusting the analyzer, refer to the following paragraphs to:

- make sure the operating environment is within its requirements
- make sure that proper electrostatic discharge (ESD) protection is provided
- make sure the analyzer has warmed up properly to achieve system stability
- review the principles of connector care

### Verify the Operating Environment

Due to their operating specifications, the verification and calibration kit devices determine your operating environment conditions. Open the calibration and verification kits and place all the devices on top of the foam inserts so they will reach room temperature. As the device dimensions change with temperature, their electrical characteristics change as well. It is necessary to keep the environmental levels within the limits stated in the *PNA Series Installation and Quick Start Guide*, Chapter 3, located online at:

<http://cp.literature.agilent.com/litweb/pdf/E8356-90001.pdf>

### Protect Against Electrostatic Discharge (ESD)

This is important. If not properly protected against, electrostatic discharge can seriously damage your analyzer, resulting in costly repair.

---

**CAUTION** To reduce the chance of electrostatic discharge, follow all of the recommendations outlined in “[Electrostatic Discharge Protection](#)” on page 1-6, for all of the procedures in this chapter.

---

### Allow the Analyzer to Warm Up

---

**NOTE** To achieve the maximum system stability, allow the analyzer to warm up for at least 90 minutes.

---

## Review the Principles of Connector Care

Proper connector care and connection techniques are critical for accurate and repeatable measurements. Refer to [Table 3-1](#) for tips on connector care.

Prior to making connections to your analyzer, carefully review the information about inspecting, cleaning, and gaging connectors. Refer to the calibration kit documentation for detailed connector care information.

For course numbers about additional connector care instruction, contact Agilent Technologies. Refer to [“Contacting Agilent”](#) on page 2-12.

**Table 3-1 Connector Care Quick Reference Guide**

Handling and Storage	
<b>Do</b> <ul style="list-style-type: none"> <li>• Keep connectors clean</li> <li>• Extend sleeve or connector nut</li> <li>• Use plastic end-caps during storage</li> </ul>	<b>Do Not</b> <ul style="list-style-type: none"> <li>• Touch mating-plane surfaces</li> <li>• Set connectors contact-end down</li> <li>• Store connectors or adapters loose</li> </ul>
Visual Inspection	
<b>Do</b> <ul style="list-style-type: none"> <li>• Inspect all connectors carefully</li> <li>• Look for metal particles, scratches, and dents</li> </ul>	<b>Do Not</b> <ul style="list-style-type: none"> <li>• Use a damaged connector - ever</li> </ul>
Connector Cleaning	
<b>Do</b> <ul style="list-style-type: none"> <li>• Try compressed air first</li> <li>• Use isopropyl alcohol<sup>a</sup></li> <li>• Clean connector threads</li> </ul>	<b>Do Not</b> <ul style="list-style-type: none"> <li>• Use any abrasives</li> <li>• Get liquid into plastic support beads</li> </ul>
Gaging Connectors	
<b>Do</b> <ul style="list-style-type: none"> <li>• Clean and zero the gage before use</li> <li>• Use the correct gage type</li> <li>• Use correct end of calibration block</li> <li>• Gage all connectors before first use</li> </ul>	<b>Do Not</b> <ul style="list-style-type: none"> <li>• Use an out-of-specification connector</li> </ul>
Making Connections	
<b>Do</b> <ul style="list-style-type: none"> <li>• Align connectors carefully</li> <li>• Make preliminary connection contact lightly</li> <li>• Turn only the connector nut</li> <li>• Use a torque wrench for final connection</li> </ul>	<b>Do Not</b> <ul style="list-style-type: none"> <li>• Apply bending force to connection</li> <li>• Over tighten preliminary connection</li> <li>• Twist or screw any connection</li> <li>• Tighten past torque wrench “break” point</li> </ul>

- a. Cleaning connectors with alcohol shall only be done with the instrument’s power cord removed, and in a well-ventilated area. Allow all residual alcohol moisture to evaporate, and the fumes to dissipate prior to energizing the instrument.

---

## About System Verification and Performance Tests

The performance of the network analyzer is specified in two ways: system specifications, and instrument specifications. It is the end user's responsibility to determine which set of specifications is applicable to their use of the PNA.

A network analyzer measurement "system" includes the analyzer, calibration kit, test cables, and any necessary adapters. **The system verification software in the PNA is used to verify the system's conformance to the "system" specifications.** A "pass" result demonstrates that the analyzer, test cables, and adapters, perform correctly as a system. It DOES NOT demonstrate that any one component performs according to its individual specifications. A change to any part of this measurement system requires a re-verification of the system.

Instrument specifications specify the network analyzer's uncorrected measurement port characteristics and its output and input behavior. **The PNA performance tests are used to verify the analyzer's conformance to "instrument" specifications.**

### System Specifications

System specifications specify warranted performance of the measurement system when making error-corrected measurements using the same calibration kit and test cables used during the system verification routine. System specifications are applicable only when the measurement system is used to make error-corrected measurements.

The analyzer's system specifications are described in the *Agilent PNA Series Network Analyzer Technical Specifications* and also in the analyzer's on-line help system in the section titled "Corrected System Performance".

System specifications are expressed in two ways:

- residual errors of the measurement system shown as tabular specification values
- graphs of measurement uncertainty versus reflection and transmission coefficients

System specifications are verified in one of the following ways:

- Complete the system verification procedure using a certified verification kit and certified calibration kit that will be used for future measurements, or
- Complete all of the performance tests using a certified calibration kit that will be used for future measurements. This alternative verifies both the system specifications and the instrument specifications for the analyzer.

### Instrument Specifications

The analyzer's instrument specifications are described in the *Agilent PNA Series Network Analyzer Technical Specifications* and also in the analyzer's on-line help system in the sections titled "Uncorrected System Performance", "Test Port Output", and "Test Port Input".

These specifications apply when the analyzer is used to make either raw or error-corrected measurements.

### System Verification Procedure

The system verification procedure tests the network analyzer measurement "system", as defined previously,

against the system specifications. If confirmation is successful, the measurement system is capable of making measurements to the accuracy specified by the graphs of measurement uncertainty.

The procedure consists of calibrating the analyzer with a calibration kit, measuring a set of characterized devices, and comparing the resultant measured data to the data and uncertainty limits supplied with the verification kit. The device data provided with the verification kit has a traceable path to NIST. The total measurement uncertainty limits for the performance verification are the sum of the factory measurement uncertainties and the uncertainties associated with measuring the same devices on the system being verified. The difference between the factory-measured data and the verification-measured data must fall within the total uncertainty limits at all frequencies for the total system uncertainty test to pass.

---

**NOTE** Calibration kits are different from verification kits. Calibration kits are used to determine the systematic errors of a network analyzer measurement system. Verification kits are used to confirm system specifications and are not used to generate error correction.

---

## Performance Tests

Performance tests are used to confirm analyzer performance against the “instrument” specifications. If confirmation is successful, the analyzer meets the instrument specifications.

Performance tests are contained in the N7840A Software Package and are described at “[Performance Tests \(Agilent N7840A Software Package\)](#)” on page 3-30.

An illustrated outline of the performance verification procedure:

- for ANSI/NCSL Z540-1-1994 verification, is shown in [Figure 3-1 on page 3-8](#).
- for non-ANSI/NCSL Z540-1-1994 verification, is shown in [Figure 3-2 on page 3-9](#).

## Certificate of Calibration

Agilent Technologies will issue a certificate of calibration upon successful completion of system verification or completion of the performance tests. The certificate of calibration will apply to the “system” (analyzer, calibration kit, test cables, and any necessary adapters) if the system verification procedure is used to confirm the system specifications. If the performance tests are used to confirm instrument specifications, the certificate of calibration will apply to the PNA as an independent instrument. The equipment and measurement standards used for the tests must be certified and must be traceable to recognized standards.

---

**NOTE** If you have a measurement application that does not use all of the measurement capabilities of the analyzer, you may ask your local Agilent Technologies service office to verify only a subset of the specifications. However, this “limited calibration” creates the possibility of making inaccurate measurements if you then use the analyzer in an application requiring additional capabilities.

---

## ANSI/NCSL Z540–1–1994 Verification

To meet the criteria for ANSI/NCSL Z540-1-1994, perform the preliminary checks and all performance tests *without stopping to repair or adjust*<sup>1</sup>. Refer to [Figure 3-1](#) for test flow. Print data at the completion of all the tests, even if you are aware that the analyzer did not pass. If there is a failure, complete the verification before you troubleshoot, repair, and adjust. After the failure has been corrected, repeat the entire set of performance tests and generate a new set of data.

**Figure 3-1** ANSI/NCSL Z540–1–1994 Test Path Verification Flowchart

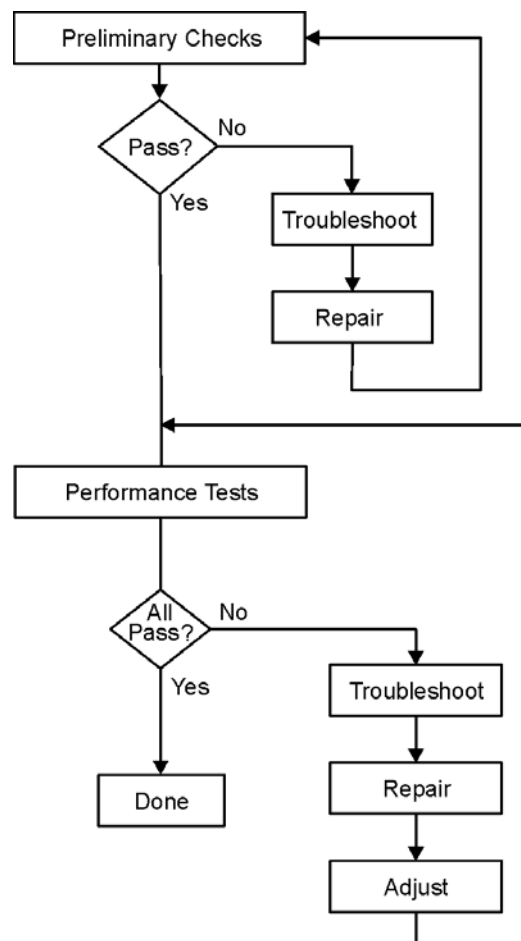

sc870b

1. Stop only in case of a catastrophic failure or cable connector damage.



## Non-ANSI/NCSL Z540-1-1994 Verification

For non-ANSI/NCSL Z540-1-1994, perform the preliminary checks and performance tests while *stopping to troubleshoot*. Refer to [Figure 3-2](#) for test flow. Troubleshoot and repair the first problem encountered without continuing to other tests. After you troubleshoot, repair, and adjust, repeat the *last failed* portion and generate a new set of data.

**Figure 3-2 Non-ANSI/NCSL Z540-1-1994 Test Path Verification Flowchart**

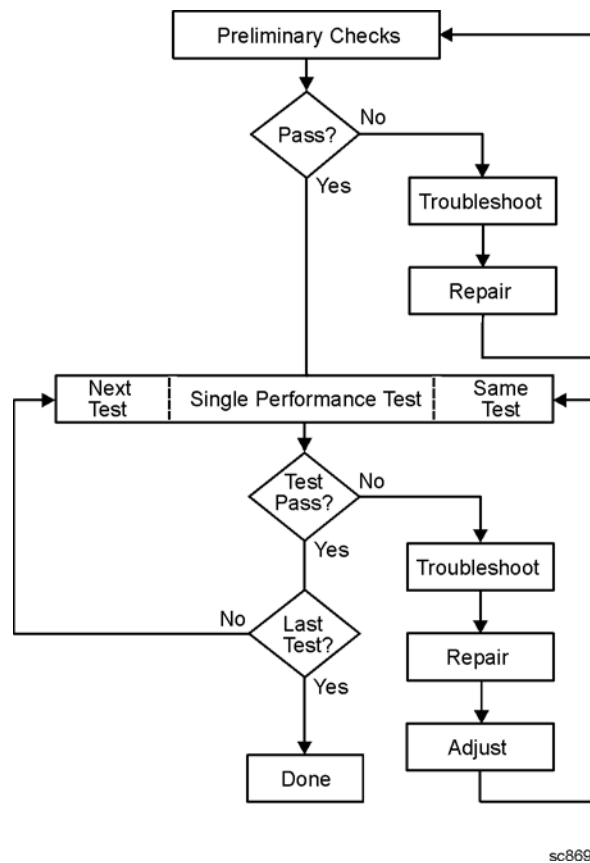

---

## Preliminary Checks

Preliminary checks include the following:

- “The Operator’s Check” on page 3-10

The operator’s check tests the network analyzer’s basic functionality of the source, switch, step attenuators, and receivers.

- “The Test Port Cable Checks” on page 3-12

The test port cable checks are not required, but are recommended to verify the performance of the test port cables before performing the verification test.

### The Operator’s Check

---

**NOTE** To achieve the maximum system stability, allow the analyzer to warm up for at least 90 minutes before performing the Operator’s Check.

---

The operator’s check is a software driven test that checks the basic operation of the assemblies in the Port 1 and Port 2 signal paths. By performing the operator’s check, the following are determined:

- repeatability of the RF test port switch
- attenuation ranges of all installed attenuators
- calibration of the receivers
- frequency response of the receivers
- phase lock and leveling
- noise floor and trace noise

#### Accessories Used in the Operator’s Check

Equipment Type	Models Used With	Part Number
Female short, 3.5 mm	E8362C	85052-60007 (from the 85052 calibration kit)
Female open, 3.5 mm	E8362C	85052-60009 (from the 85052 calibration kit)
Female short, 2.4 mm	E8363C, E8364C	85056-60021 (from the 85056 calibration kit)
Female open 2.4 mm	E8363C, E8364C	85056-60023 (from the 85056 calibration kit)

#### Performing the Operator’s Check

1. From the **System** menu, point to **Service**, and then click **Operator’s Check**.
2. In the **PNA Operator’s Check** dialog box (refer to [Figure 3-3](#)), under **Configure**, select either **Prompt for attachment of Short/Open**, to pause at each step in the process to allow moving the short/open to the appropriate port, or **Shorts/Opens are attached to ALL ports**, to run through the test without stopping. Shorts and opens can be mixed on the test ports.
3. Click **Begin**.

- If shorts and opens are not connected to all ports, you will be prompted to connect them as they are needed.
- The result of the operator's check will be shown as a PASS or FAIL next to each test (refer to [Figure 3-3](#)). The PNA Operator's Check dialog box will look different for different PNA model numbers and installed options. Some of the tests are performed only if the appropriate options are installed in the PNA.

**Figure 3-3 Operator's Check Dialog Box**

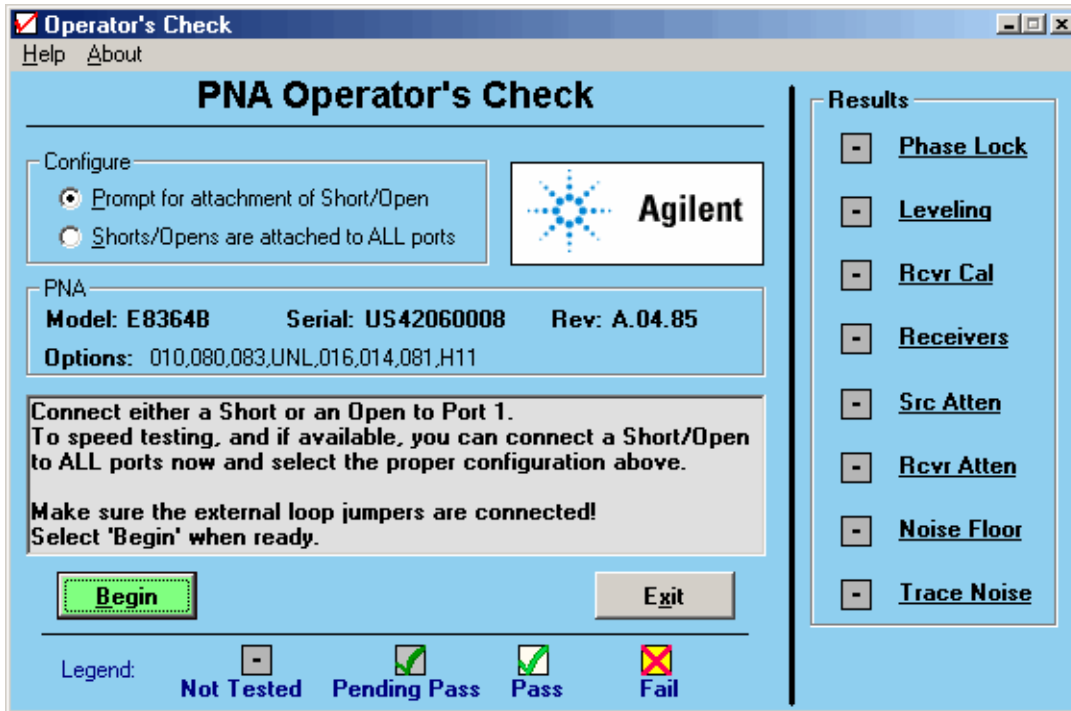

### If the Operator's Check Fails

- Clean the test ports, shorts, and adapters. Torque connections to specification. Repeat the check.
- If the check still fails, suspect a faulty component. Refer to ["Measurement System Troubleshooting"](#) on [page 4-24](#) to begin troubleshooting to determine the faulty component.

## The Test Port Cable Checks

A faulty test port cable can cause a failure in the verification test. The following checks are not required, but are recommended to verify the performance of the test port cable.

- “Cable Return Loss Check” on page 3-13
- “Cable Insertion Loss Check” on page 3-14
- “Cable Magnitude and Phase Stability Check” on page 3-15
- “Cable Connector Repeatability Check” on page 3-17

### Accessories Used in the Test Port Cable Checks

Equipment Type	Models Used With	Model or Part Number	Alternate Model or Part Number
Calibration kit, 3.5 mm	E8362C	85052B	85052D
RF cable, 3.5 mm (f) to 3.5 mm (f)	E8362C	85131C	85131E
Calibration kit, 2.4 mm	E8363C, E8364C	85056A	85056D
RF cable, 2.4 mm (f) to 2.4 mm (f)	E8363C, E8364C	85133C	85133E

### Cable Return Loss Check

1. Press **Preset**.
2. Perform a one-port calibration on Port 1, **1-Port Reflection**. Refer to the embedded help in the analyzer if necessary.
3. Connect the test port cable to Port 1. Connect a broadband load to the other end of the cable. Tighten to the specified torque for the connector type.

The analyzer now displays the return loss of the cable.

4. From the **Marker** menu, click **Marker Search**. In the **Marker Search** dialog box, in the **Search Type** box, make sure **Maximum** is selected. Click **Execute**, and then click **OK**.
5. The marker annotation on the screen indicates the worst case return loss. Refer to the cable manual to see if it meets the return loss specification. For an example of a typical return loss measurement, see [Figure 3-4](#).

**Figure 3-4** Typical Cable Return Loss Response

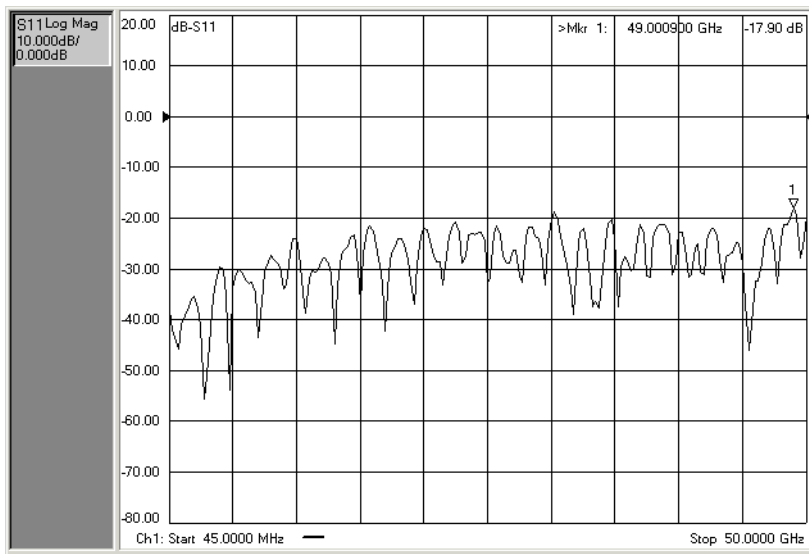

### If the Cable Return Loss Check Fails

1. Clean the cable and devices and torque to specification. Repeat the check.
2. If the check still fails, the cable should be repaired or replaced.

### Cable Insertion Loss Check

1. With the test port cable still connected to Port 1, connect a short to the other end of the cable.
2. From the **Marker** menu, click **Marker Search**. In the **Marker Search** dialog box, in the **Search Type** box, select **Minimum**. Click **Execute**, and then click **OK**.
3. The displayed response is twice the actual loss. To get the actual worst case insertion loss, divide the value at the marker annotation by two. Refer to the cable manual to see if it meets the insertion loss specification. For an example of a typical insertion loss measurement, see [Figure 3-5](#).

**Figure 3-5** Typical Cable Insertion Loss Response

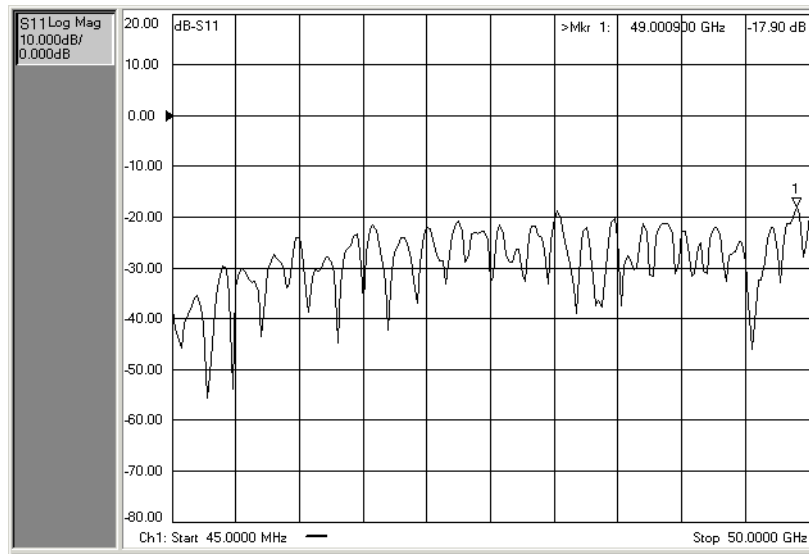

### If the Cable Insertion Loss Check Fails

1. Clean the cable and devices and torque to specification. Repeat the check.
2. If the check still fails, the cable should be repaired or replaced.

### Cable Magnitude and Phase Stability Check

1. With the test port cable still connected to Port 1, connect a short to the other end of the cable.
2. Press **Preset**.
3. On the **Trace** menu, click **New Trace**. In the **New Trace** dialog box, click the **S11** box, and then click **OK**.
4. On the **Trace** menu, click **Format**. In the **Format** dialog box, click **Phase**, and then click **OK**.
5. On the **Channel** menu, click **Average**. In the **Average** dialog box, click the **Average ON** check box. In the **Average Factor** box, type 50 or click the arrows to select 50, and then click **OK**.
6. To provide a good reference, hold the test cable in a straight line perpendicular to the front panel of the network analyzer.
7. On the **Channel** menu, click **Restart Avg**.
8. Wait for the analyzer to average the measurement 50 times (approximately two seconds).
9. To normalize the data trace:
  - a. On the **Trace** menu, click **Math/Memory**.
  - b. In the **Math/Memory** dialog box, click the **Data->Memory** button.
  - c. In the **Data Math** list, select **Data/Memory**.
  - d. Under **Trace View Options**, make sure **Data Trace** is selected.
  - e. Click **OK**.
10. Slowly make a 180 degree bend in the middle of the cable and hold it in that position.
11. For each trace: On the **Scale** menu, set the **Scale Per Division** for optimum viewing as shown in [Figure 3-6](#).
12. Place a marker on the largest deflection that goes above the reference line and is within the cable's specified frequency range. For a typical response of cable magnitude and phase stability, see [Figure 3-6](#).
13. Place a marker on the largest deflection that goes below the reference line and is within the cable's specified frequency range.

In this  $S_{11}$  measurement, the displayed trace results from energy being propagated down the cable and reflected back from the short. Therefore, the measured deflection value must be divided in half to reach the correct value.

**Figure 3-6 Typical Cable Magnitude and Phase Stability Response**

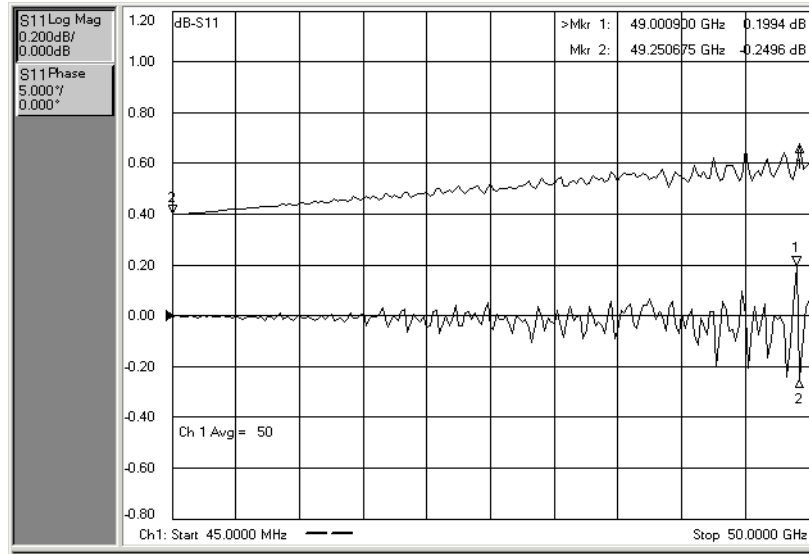

**If the Cable Magnitude and Phase Stability Check Fails**

1. Clean the cable and devices and torque connections to specifications (refer to “Review the Principles of Connector Care” on page 3-5). Repeat the check.
2. If the check still fails, the cable should be repaired or replaced.



## Cable Connector Repeatability Check

---

**NOTE** The connector repeatability measurement should be done at the test port as well as at the end of the test port cable.

---

1. With the test port cable still connected to Port 1, connect a broadband load to the other end of the cable.
2. Press **Preset**.
3. On the **Channel** menu, click **Average**. In the **Average** dialog box, click the **Average ON** check box. In the **Average Factor** box, type 100 or click the arrows to select 100. Click **OK**.
4. Wait for the analyzer to average the measurement 100 times (approximately five seconds).
5. To normalize the data trace:
  - a. On the **Trace** menu, click **Math/Memory**.
  - b. In the **Math/Memory** dialog box, click the **Data->Memory** button.
  - c. In the **Data Math** list, select **Data/Memory**.
  - d. Under **Trace View Options**, make sure **Data Trace** is selected.
  - e. Click **OK**
6. To adjust the display scale:
  - a. On the **Scale** menu, click **Scale**.
  - b. In the **Scale Per Division** box, click the arrow to select **0.5 dB**.
  - c. In the **Level** box under **Reference** click the arrow to select **0 dB**.
  - d. Click **OK**.
7. Disconnect and then reconnect the cable to the test port. Tighten the connection to the specified torque for the connector type.
8. On the **Channel** menu, click **Restart Avg**.
9. Look at the trace for spikes or modes.
10. To re-normalize the data trace of the reconnected cable:
  - a. On the **Trace** menu, click **Math/Memory**.
  - b. In the **Math/Memory** dialog box, click the **Data->Memory** button.
  - c. Click **OK**.
11. Repeat steps 7 through 9 at least three times to look for modes. Modes appear when a harmonic of the source fundamental frequency is able to propagate through the cable or connector. It is helpful to print a plot of the trace each time to compare several connections. If any mode appears each time the cable is connected and reconnected, measurement integrity will be affected.

For a typical response of cable connector repeatability, see [Figure 3-7](#).
12. For the Port 2 Check, connect the cable (with the load attached) to Port 2 and repeat steps 2 through 11.

**Figure 3-7 Typical Cable Connector Repeatability Response**

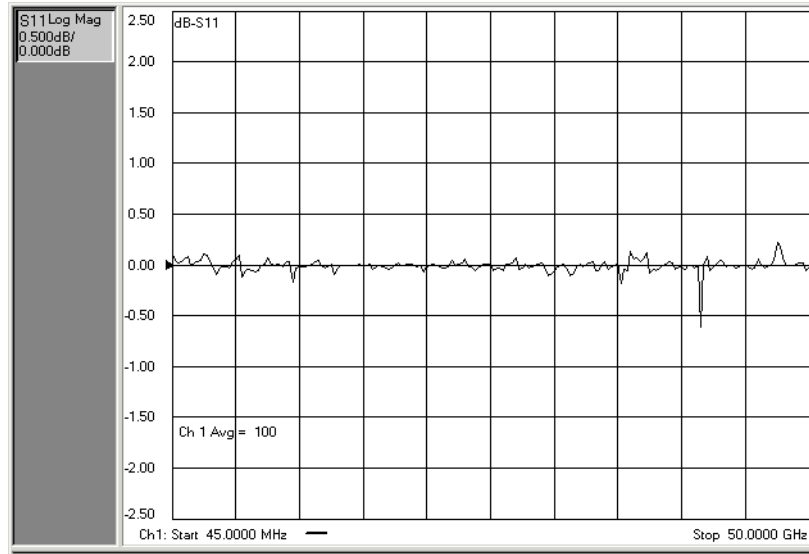

**If the Cable Connector Repeatability Check Fails**

1. Clean the cable and devices, and torque connections to specifications (refer to [“Review the Principles of Connector Care”](#) on page 3-5). Repeat the check.
2. If the check still fails, the cable should be repaired or replaced.

---

## System Verification

System verification is used to verify system-level, error-corrected uncertainty limits for network analyzer measurements. The verification procedure is automated and is contained in the firmware of the analyzer.

The device data provided with the verification kit has a traceable path to a national standard. The difference between the supplied traceable data and the measured data must fall within the total uncertainty limits at all frequencies for the system verification to pass.

The total measurement uncertainty limits for the system verification are the sum of the factory measurement uncertainties for the verification devices and the uncertainties associated with the system being verified. You can determine your system measurement uncertainty limits by referring to the analyzer embedded on-line help.

---

**IMPORTANT** Passing this system verification does not guarantee that the analyzer meets all of its performance specifications. However, it does show that the network analyzer being verified measures the same devices with the same results as a factory system which has had all of its specifications verified and its total measurement uncertainty minimized.

---

### What the System Verification Verifies

The system verification procedure verifies proper operation of the:

- network analyzer
- calibration kit
- test port cables

together as a “system”. It DOES NOT verify that any of these components pass their specifications independently. The user is responsible for independently calibrating and verifying the proper operation of the calibration kit and test port cables prior to performing the system verification.

---

**NOTE** Additional equipment or accessories used with the above system are not verified by system verification.

---

## Measurement Uncertainty

Measurement uncertainty is defined as the sum of:

- the residual systematic (repeatable) errors, and
- the random (non-repeatable) errors

in the measurement system after calibration.

The systematic errors are:

- directivity,
- source match,
- load match,
- reflection and transmission frequency tracking, and
- isolation (crosstalk).

The random errors include:

- noise,
- drift,
- connector repeatability, and
- test cable stability.

A complete description of system errors and how they affect measurements is provided in the analyzer's on-line embedded help.

Any measurement result is the vector sum of the actual test device response plus all error terms. The precise effect of each error term depends on its magnitude and phase relationship to the actual test device response. When the phase of an error response is not known, phase is assumed to be worst-case ( $-180^\circ$  to  $+180^\circ$ ). Random errors such as noise and connector repeatability are generally combined in a root-sum-of-the-squares (RSS) manner.

### Measurement Traceability

To establish a measurement traceability path to a national standard for a network analyzer system, the overall system performance is verified through the measurement of devices that have a traceable path. This is accomplished by measuring the devices in an Agilent verification kit.

The measurement of the devices in the verification kit has a traceable path because the factory system that measured the devices is calibrated and verified by measuring standards that have a traceable path to the National Institute of Standards and Technology (NIST) (see Figure 3-8). This chain of measurements defines how the verification process brings traceability to the network analyzer system.

Figure 3-8 NIST Traceability Path for Calibration and Verification Standard

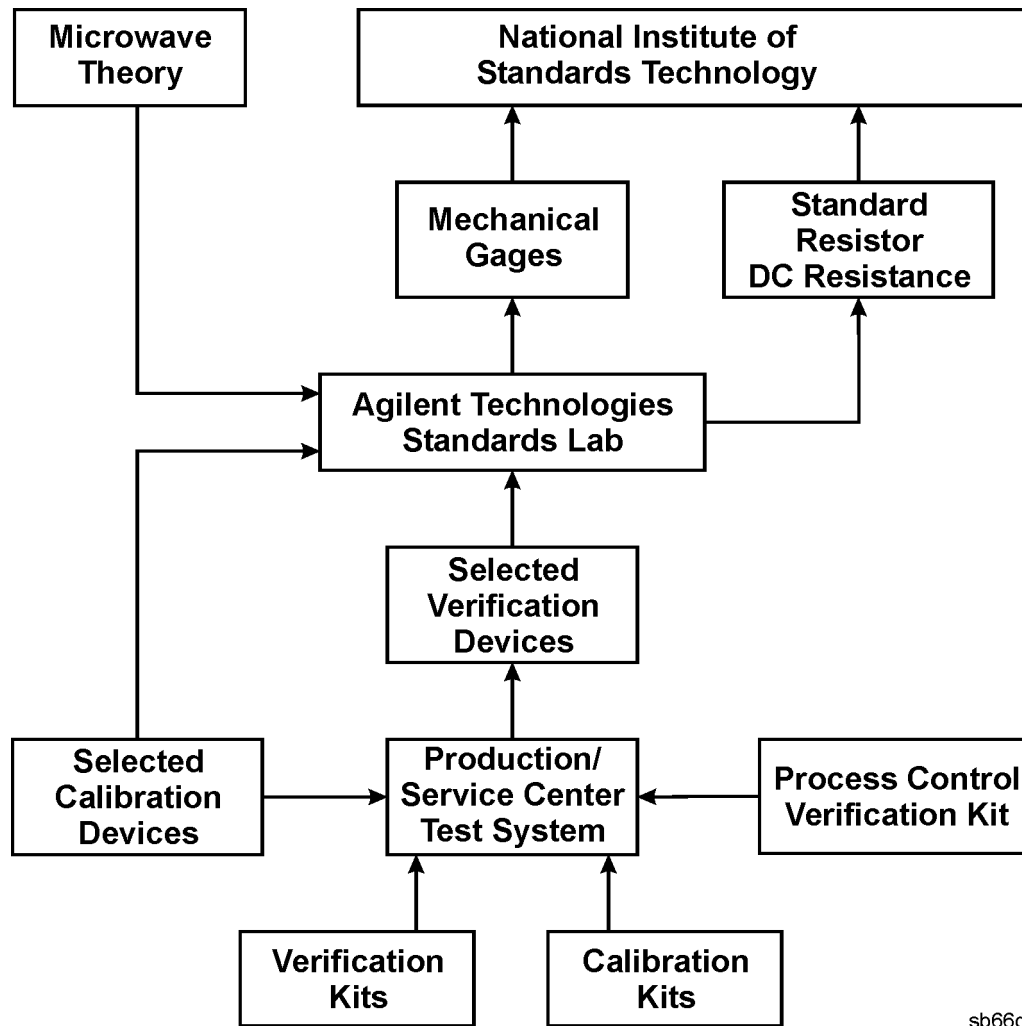

sb66d

## Performing System Verification

The following verification procedure is automated by the analyzer firmware. For each verification device, the analyzer reads a file from the verification disk and sequentially measures the magnitude and phase for all four S-parameters.

---

**IMPORTANT** For system verification to perform correctly, it is NECESSARY that the verification devices be measured with their female connectors connected to Port 1 and their male connectors connected to Port 2.

---

**NOTE** The following procedure, and the connection prompts given, assumes only one female-to-female cable connected to Port 2. However, this procedure can also be performed with the addition of a female-to-male cable connected to Port 1.

---

**NOTE** Although the performance for all four S-parameters are measured, the  $S_{11}$  and  $S_{22}$  phase uncertainties for the attenuators and airlines are less important for verifying system performance. Therefore, the limit lines will not appear on the printout.

---

### Equipment Supported by the System Verification Procedure

Equipment Type	Type-N	3.5 mm	2.4 mm
	E8362C	E8362/3/4C	E8363/4C
Calibration kit	85054B/D	85052B/D	85056A/D
Verification kit	85055A	85053B	85057B
Cables	85131C/E (with 85130C 3.5 mm to Type-N adapter set)	E8362C: 85131C/E E8363/4C: 85133C/E (with 85130F 2.4 mm to 3.5 mm adapter set)	85133C/E

### Cable Substitution

The test port cables specified for the network analyzer system have been characterized for connector repeatability, magnitude and phase stability with flexing, return loss, insertion loss, and aging rate. Since test port cable performance is a significant contributor to the system performance, cables of lower performance will increase the uncertainty of your measurement. Refer to the plots in the cable tests (earlier in this chapter) that show the performance of good cables. It is highly recommended that the test port cables to be regularly tested.

If the system verification is performed with a non-Agilent cable, ensure that the cable meets or exceeds the specifications for the RF cable specified in the above table, "[Equipment Supported by the System Verification Procedure](#)." Refer to the cable's user's guide for specifications.

### Kit Substitution

Non-Agilent calibration kits and verification kits are not recommended nor supported.

### Precautions for Handling Airlines

The verification kit includes airlines. Follow the steps below to ensure good measurement techniques.

- Be very careful not to drop the airline's center or outer conductor. Irreparable damage will result if these devices are dropped.
- During this procedure, you will be touching the exposed center conductor of the test port and the center conductor of the airline.
  - Observe proper ESD procedures.
  - Clean your hands or wear gloves; skin oils will cause a change in electrical performance.
- Refer to [Figure 3-9](#), [Figure 3-10](#), and to your calibration kit manual for connection procedures.

**Figure 3-9**      **Aligning the Center Conductor**

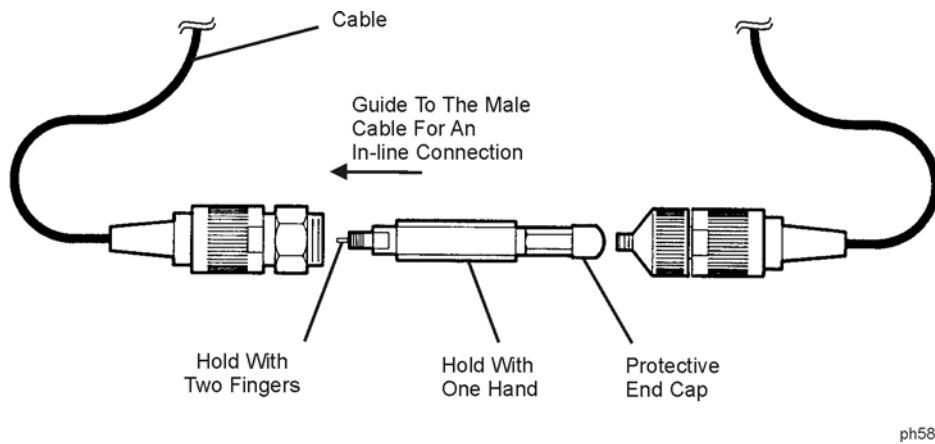

**Figure 3-10**      **Torquing the Connection**

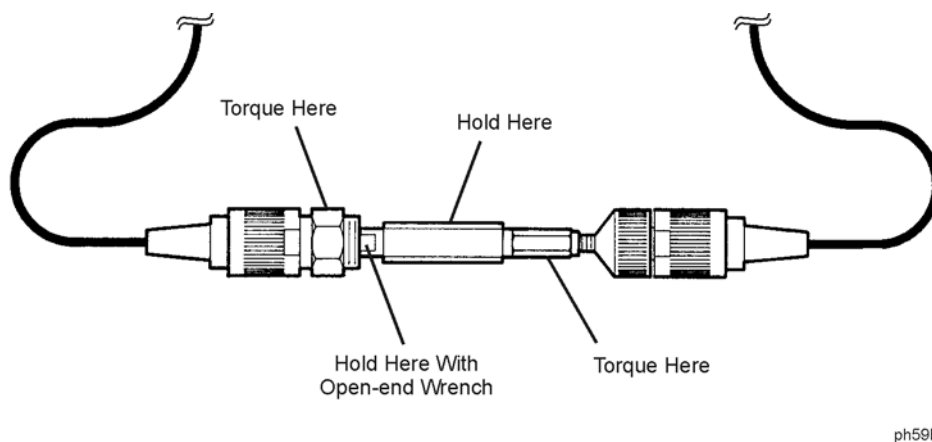

### System Verification Procedure

1. Connect a cable to the analyzer as shown in [Figure 3-11](#). If you desire printed test outputs, connect a printer to the analyzer. For the printer, ensure that the correct driver is loaded and the printer is defined as the default printer. Refer to the embedded help in the analyzer for printer setup. Let the analyzer warm up for at least 90 minutes.

**Figure 3-11** System Verification Test Setup

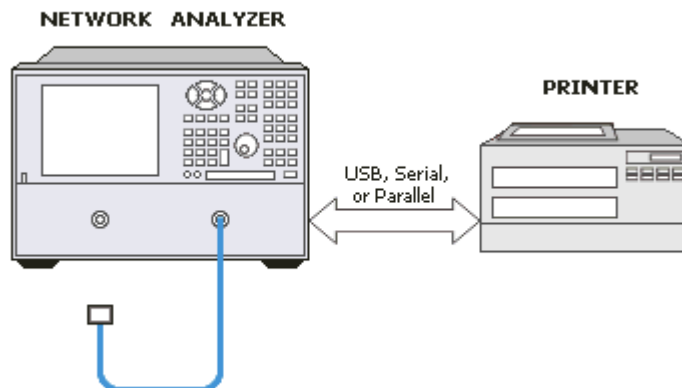

2. Insert the verification kit disk into the analyzer disk drive.
3. On the **System** menu, point to **Service**, and then click **System Verification**. The **System Verification** dialog box is displayed; refer to [Figure 3-12](#).

**Figure 3-12** System Verification Dialog Box

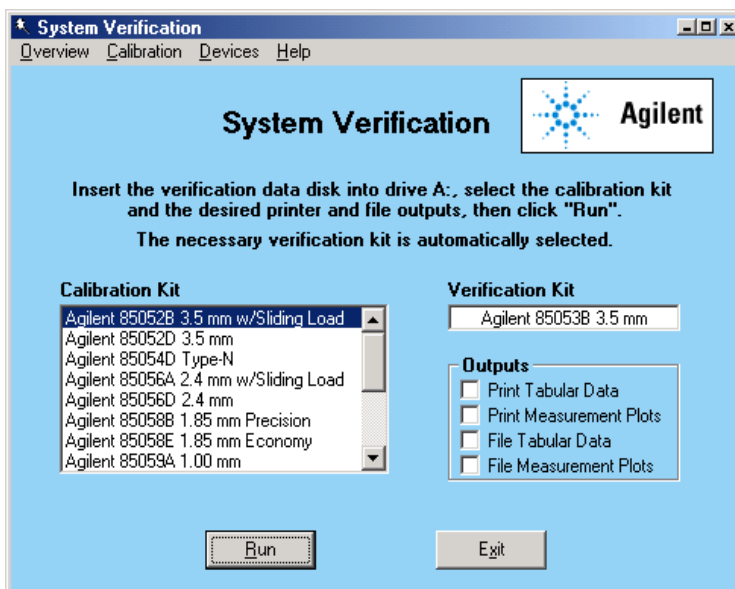



4. In the **Calibration Kit** box, select the calibration kit that is being used by clicking on it. The corresponding verification kit to use is selected for you and displayed in the **Verification Kit** box. Refer to [Figure 3-12](#).
5. Under **Printer Output**, click one of the following options. Refer to [Figure 3-12](#).
  - **None**: No printout of results.
  - **Tabular Data**: Prints the verification data in tabular form which includes measured data and uncertainty limits. For an example, refer to [Figure 3-15 on page 3-27](#).
  - **Measurement Plots**: Prints the verification data in graphical form. The graphical form includes the measured data trace, factory supplied data trace, and uncertainty limits. For an example, refer to [Figure 3-16 on page 3-28](#).
  - **Both**: Prints the verification data in both formats.

---

**NOTE** For printed output, it is assumed that the printer has been tested and the Windows 2000 driver is installed for the printer that is being used. The system verification test prints to the printer that has been designated as the default printer. (On the Windows Desktop display, click on **My Computer**, **Control Panel**, and then **Printers** to verify the printer setup.)

---

6. Click **Run**.
7. Follow the instructions on the analyzer for performing a full 2-port calibration.
8. After completion of the full 2-port calibration, follow the instructions on the analyzer for performing the system verification.

For the system verification, insert the devices as shown in [Figure 3-13](#).

**Figure 3-13 System Verification Device Connections**

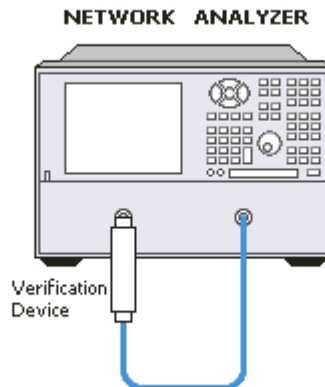

### If the System Fails the Verification Test

**IMPORTANT** Inspect all connections. *Do not* remove the cable from the analyzer test port. This *will invalidate* the calibration that you performed earlier.

1. Disconnect and clean the device that failed the verification test.
2. Reconnect the device making sure that all connections are torqued to the proper specifications.
3. Measure the device again.
4. If the analyzer still fails the test, check the measurement calibration by viewing the error terms as described in ["Accessing Error Terms" on page 8-8](#).
5. Refer to [Figure 3-14](#) for additional troubleshooting steps.

**Figure 3-14 System Verification Failure Flowchart**

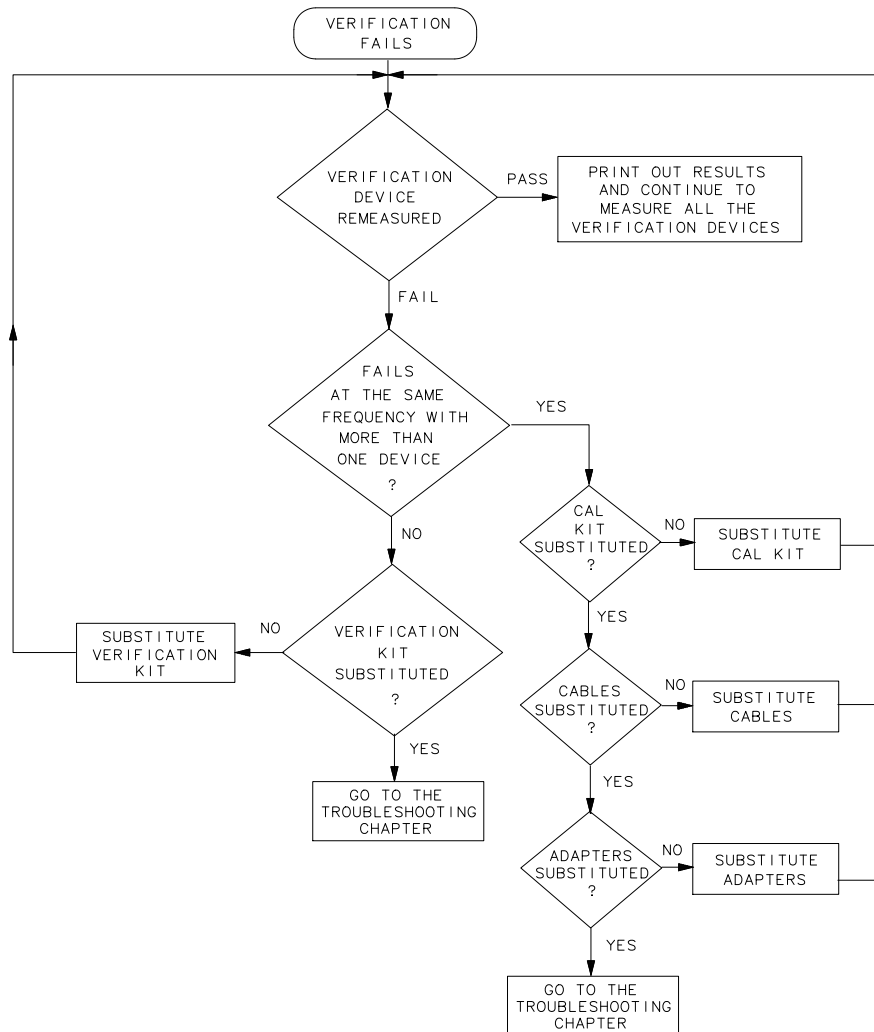

sb69d

**Interpreting the Verification Results**

Figure 3-15 shows an example of typical verification results with **Tabular Data** selected in the **Printer Output** area of the **System Verification** dialog box.

At the top of the printed output is the name of the device, the serial number of the device, and the date tested.

Each S-parameter measurement result is printed with frequency tested, lower and upper limit lines, the measured data, and the result of the test.

**Figure 3-15 Example of Printed Tabular Verification Results**

Sys Ver -- 20 dB attenuator magnitude results, Serial #00810 -- 6 Sep 2000

S11 Results

Frequency	Lower Limit	Measured Data	Upper Limit	Result
0.3 MHz	0.0048 Units	0.0090 Units	0.0139 Units	PASS
100	0.0046	0.0091	0.0137	PASS
200	0.0042	0.0092	0.0134	PASS
300	0.0040	0.0091	0.0133	PASS
400	0.0038	0.0089	0.0131	PASS
500	0.0036	0.0087	0.0129	PASS
600	0.0034	0.0085	0.0127	PASS
700	0.0031	0.0082	0.0125	PASS
800	0.0029	0.0080	0.0122	PASS
900	0.0026	0.0079	0.0119	PASS
1000	0.0023	0.0075	0.0117	PASS
1100	0.0020	0.0072	0.0114	PASS
1200	0.0017	0.0068	0.0111	PASS
1300	0.0013	0.0064	0.0107	PASS
1400	-0.0006	0.0059	0.0118	PASS
1500	-0.0011	0.0052	0.0113	PASS
1600	-0.0015	0.0044	0.0108	PASS
1700	-0.0020	0.0038	0.0103	PASS
1800	-0.0026	0.0032	0.0097	PASS
1900	-0.0031	0.0024	0.0091	PASS
2000	-0.0036	0.0019	0.0085	PASS
2100	-0.0045	0.0016	0.0082	PASS
2200	-0.0050	0.0018	0.0077	PASS
2300	-0.0054	0.0023	0.0073	PASS
2400	-0.0052	0.0031	0.0075	PASS
2500	-0.0048	0.0039	0.0080	PASS
2600	-0.0040	0.0050	0.0087	PASS
2700	-0.0032	0.0060	0.0094	PASS
2800	-0.0024	0.0071	0.0103	PASS
2900	-0.0014	0.0082	0.0113	PASS
3000	-0.0004	0.0095	0.0124	PASS

Overall PASS/FAIL result for entire frequency range = PASS

Figure 3-16 shows an example of typical verification results with **Measurement Plots** selected in the **Printer Output** area of the **System Verification** windows. The printed graphical results show the following:

- the name of the device measured
- the serial number of the device
- the parameters measured
- Results of the measurements. Labeled as A in Figure 3-16.
- Data measured at the factory from the verification kit. Labeled as B in Figure 3-16.
- Upper and lower limit points as defined by the total system uncertainty system. Labeled as C in Figure 3-16.

**Figure 3-16 Example of Printed Graphical Verification Results**

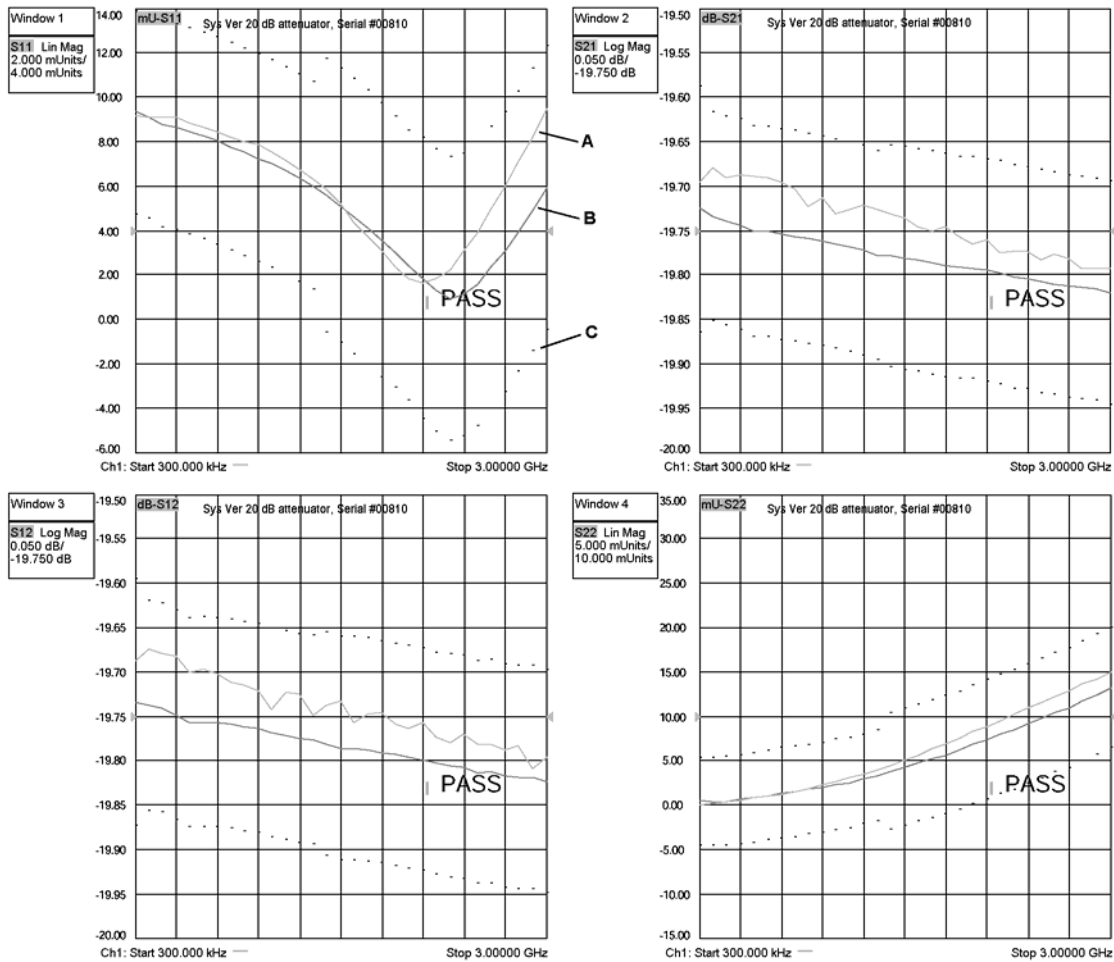

---

## Option H11, IF Access, Operation Verification

To verify that the Option H11, IF Access, is functioning properly:

1. Download and install the verification program from the Web:
  - a. Go to website: <http://na.tm.agilent.com/pna/support/>.
  - b. Download file: H11VerifyInstall.exe to the C:\ drive on the PNA.
  - c. After the file has finished loading, double click on the filename. At this point the file will self-extract and load into its default file location. Allow this process to complete, uninterrupted.
2. Create (if necessary) a macro for the verification program:
  - a. On the analyzer's **System** menu, point to **Macro**. If a macro named **H11Verify** is present in the list, proceed to step 3. If not, continue here to create the macro.
  - b. Click **Macro Setup**.
  - c. In the **Macro Setup** window, click on the first blank line in the list (the next line after the last entry). Click **Edit**.
  - d. In the **Edit Macro Setup** window, enter **H11Verify** as the **Macro Title**.
  - e. Click **Browse**.
  - f. In the **Open** window, navigate to Network Analyzer/Service/H11Verify.exe. Click **Open**. This places the H11Verify.exe filename in the **Macro Executable** box in the **Macro Setup** window.
  - g. In the **Macro Setup** window, click **OK**.
  - h. The macro should now be entered in the list in the **Macro Setup** window.
  - i. Click **OK**.
3. Run the H11Verify macro:
  - a. On the analyzer's **System, Macro** menu, click **H11Verify**.

---

## Performance Tests (Agilent N7840A Software Package)

The Agilent N7840A software package verifies the electrical performance of your E8362/3/4C PNA series microwave network analyzer. The software automatically configures your analyzer to execute the performance tests. The N7840A software package is not included with the analyzer; it must be ordered separately. The model numbers of the equipment used are specified under “[Required Service Test Equipment](#)” on page 2-8.

There are nine tests in the software package:

- [Source Power Linearity Test](#)
- [Source Maximum Power Output Test](#)
- [Source Power Accuracy Test](#)
- [Frequency Accuracy Test](#)
- [Trace Noise Test](#)
- [Receiver Compression Test](#)
- [Noise Floor Test](#)
- [Calibration Coefficient Test](#)
- [System Crosstalk Test](#)
- [Dynamic Accuracy Test](#)

---

**IMPORTANT** The descriptions of these tests are provided here as a convenience only. These tests are subject to change at any time. As a result of such change, the descriptions provided here may no longer be accurate. Refer to the N7840A product itself for the latest, most accurate descriptions of the tests.

---

### Source Power Accuracy Test

**Function of the Test:** To confirm the accuracy of the source output power of your network analyzer over its full frequency range.

**Specification Tested:** Test Port Output–Power Level Accuracy

**Equipment Used:** A power meter, power sensors, and adapters.

**Description of the Test:**

1. The analyzer’s output power level is set to 0 dBm.
2. A power sensor is connected to Port 1.
3. The output power is measured at hundreds of CW frequencies across the analyzer’s frequency range and the values compared to the setting of 0 dBm.

**If the Analyzer Fails this Test:**

- Perform the “[Source Calibration Adjustment](#)” on page 3-45 and repeat this test.
- If the analyzer still fails this test, replace the source assembly and repeat this test. Refer to “[Removing and Replacing the A12 Source 20](#)” on page 7-22.

## Source Maximum Power Output Test

**Function of the Test:** To confirm the maximum source output power of your network analyzer over its full frequency range.

**Specification Tested:** Test Port Output–Maximum Leveled Power

**Equipment Used:** A power meter, power sensors, and adapters.

### Description of the Test:

1. A power sensor is connected to Port 1.
2. The analyzer's output is set to hundreds of CW frequencies and, at each frequency, the output power is increased until an "UNLEVELED" error is detected.
3. The power level at this point is measured and compared to the maximum output power specification.

### If the Analyzer Fails this Test:

- Go to "[Checking the Signal through the Signal Separation Path](#)" on page 4-39 for troubleshooting information to determine the faulty assembly.

## Source Power Linearity Test

**Function of the Test:** To verify that the power level is linear over the analyzer's frequency range and to check the linearity of the automatic leveling control (ALC).

**Specification Tested:** Power Sweep Range and Power Level Linearity

**Equipment Used:** A test cable. (And a 20 dB pad if the analyzer does not have an internal step attenuator.)

### Description of the Test:

1. The Port 2 receiver is used to test Port 1. The receiver linearity is the standard against which the source linearity is checked.
2. A test cable is connected between Port 1 and Port 2 with 20 dB of attenuation in series with the cable. This can be done with an internal step attenuator or an external 20 dB pad. This attenuation ensures that the receiver remains in its linear range.
3. The analyzer is set to 25 different points across its frequency range.
4. At each frequency point, the output power level on Port 2 is set to 0.000 dBm and the power is measured to establish a reference,  $P_{\text{reference}}$ .
5. The source setting is then stepped from -15 to +10 dBm in 1 dB steps and the power is measured,  $P_{\text{measured}}$ , at each setting.
6. The non-linearity in dB at each frequency point is calculated as:  
$$(P_{\text{measured}} - P_{\text{reference}}) - (\text{source setting})$$

### If the Analyzer Fails this Test:

- Perform the "[Source Calibration Adjustment](#)" on page 3-45 and repeat this test.
- If the analyzer still fails this test, replace the source assembly and repeat this test. Refer to "[Removing and Replacing the A12 Source 20](#)" on page 7-22.

## Frequency Accuracy Test

**Function of the Test:** To verify the frequency accuracy and range of the analyzer's source output.

**Specification Tested:** Test Port Output–CW Accuracy

**Equipment Used:** A frequency counter, a test cable, and adapters.

**Description of the Test:**

1. Port 1 is connected to a frequency counter.
2. A series of frequencies across the band are checked.

**If the Analyzer Fails this Test:**

- Verify the accuracy of the 10 MHz OCXO by connecting a frequency counter to the rear-panel 10 MHz REF OUT.
- If the 10 MHz reference is off by more than 10 Hz, perform the [“10 MHz Frequency Reference Adjustment” on page 3-39](#) and also the [“3.8 GHz PMYO Frequency Adjustment” on page 3-40](#) and repeat this test.

## Trace Noise Test

**Function of the Test:** To measure the stability of a signal in the internal source and receiver system of your analyzer.

**Specification Tested:** Test Port Input–Trace Noise Magnitude and Trace Noise Phase

**Equipment Used:** A test cable.

**Description of the Test:**

1. Port 1 and Port 2 are connected with a test cable.
2. The analyzer is set to a series of CW frequencies across its frequency range.
3. Magnitude and phase are measured at each frequency at a 1 kHz IF bandwidth, in both directions.
4. All measurements are made at a nominal power level of 0 dBm and with 201 points per sweep.

**If the Analyzer Fails this Test:**

- Repeat this test. It is unlikely for the analyzer to fail this test without a complete failure of the network analyzer system.
- If the analyzer still fails this test, perform the [“Receiver Calibration Adjustment” on page 3-47](#) and repeat this test.



## Receiver Compression Test

**Function of the Test:** To measure the compression at the analyzer's specified maximum power level for the receivers.

**Specification Tested:** Test Port Input–Maximum Test Port Input Level

**Equipment Used:** The compression test set (Z5623A Option K01), a power meter, power sensors, two test cables, and a calibration kit. (And 10-dB and 20-dB pads if the analyzer does not have an internal step attenuator.)

### Description of the Test:

1. All measurements are made with a 1 kHz IF bandwidth and 201 points per sweep.
2. The measurements are made separately on each port.
3. The analyzer is set to various CW frequencies across the range of the analyzer.
4. A power sensor is connected to the "signal source point" to be used to test the port. The "signal source point" may be either the port connector itself, when a short is used, or the end of the test cable, when the compression test set is used to source the test signal.
5. The analyzer source output level is adjusted to create the maximum power level specified for the receiver.
6. The power sensor is disconnected and the "signal source point" is connected to the port to be tested.
7. The absolute log magnitude value (dBm) for the reference channel on the source port is read.
8. The log magnitude ratioed measurement using the receiver under test is read: ( $P_a$ ).
9. The source output level is adjusted to decrease the output by 15 dB.
10. The log magnitude ratioed measurement using the receiver under test is read: ( $P_b$ ).
11. Attenuation of 20 dB is introduced between the source and receiver. This can be done with an internal step attenuator, an external 10 dB pad (if a short is being used to reflect the signal back into the port), or an external 20 dB pad (if the signal source is the compression test set).
12. The log magnitude ratioed measurement using the receiver under test is read: ( $P_c$ ).
13. The source output level is adjusted to produce a reading of Pref (within  $\pm 0.03$  dBm) for the reference channel on the source port.
14. The log magnitude ratioed measurement using the receiver under test is read: ( $P_d$ ).
15. The compression in dB =  $(P_a - P_b) - (P_d - P_c)$ .

### If the Analyzer Fails this Test:

- Repeat this test. There are no adjustments that can be made.
- Since all four receivers are identical, the suspect failed receiver can be swapped with one of the other receivers to verify that it is faulty. Swap the suspect receiver and repeat this test. Refer to ["Removing and Replacing the A31, A32, A33, and A34 Receiver Modules and A49 IF Multiplexer Board"](#) on page 7-54.
- If the faulty channel "follows" the receiver, replace the receiver. If the same channel (now with a different receiver) is still faulty, suspect the associated cabling.

## Noise Floor Test

**Function of the Test:** To measure the absolute power level of the noise floor for the analyzer's receivers.

**Specification Tested:** Test Port Input–Test Port Noise Floor

**Equipment Used:** A power meter, power sensor, a calibration kit, and a test cable.

### Description of the Test:

1. The analyzer is set to various CW frequencies across its frequency range at an IF bandwidth of 1 kHz and 801 points per sweep.
2. A test cable is connected to the driving port for the measurement and a power sensor is connected to the other end of the cable.
3. The power level at the end of the cable is set to -5.00 dBm.
4. The power sensor is disconnected and the cable is connected to the port to be tested.
5. The absolute power level in dBm (log magnitude) is read: ( $P_{\log}$ ).
6. The test cable is removed and loads are connected to both ports.
7. The analyzer's trace is set to represent the absolute power level (linear magnitude) for the receiver under test and a sweep is taken.
8. The mean of the points on the trace, in watts, is read: ( $P_{\text{lin}}$ ).
9. Average power in dBm is calculated:  $P_{\text{dBm}} = 10 * \text{Log}_{10}(P_{\text{lin}} * 1000)$ .
10. Corrected noise floor in dBm for a 10 Hz IF bandwidth =  $P_{\text{dBm}} - 19.96 \text{ dB} - (5.00 - P_{\log})$ .

### If the Analyzer Fails this Test:

- A failure of this test indicates a failure of one or more of the following assemblies.
  - A31 channel A receiver
  - A34 channel B receiver
  - A6 SPAM board
- Since all four receivers are identical, the channel A and channel B receivers can be swapped with the channel R1 and channel R2 receivers to determine if they are the cause of the failure. Refer to [“Removing and Replacing the A31, A32, A33, and A34 Receiver Modules and A49 IF Multiplexer Board” on page 7-54](#). After swapping the receivers, repeat this test.
- If the analyzer still fails this test, replace the A6 SPAM board and repeat this test. Refer to [“Removing and Replacing the A6, A8, A9, and A10 Boards” on page 7-18](#).

## Calibration Coefficient Test

**Function of the Test:** To verify the uncorrected calibration coefficients of your analyzer. The calibration coefficients are measured in forward and reverse direction. Refer to [“Error Terms” on page 8-3](#) for error term information relating to the calibration coefficients measured.

**Specification Tested:** Uncorrected System Performance

**Equipment Used:** A calibration kit and a test cable.

### Description of the Test:

1. A series of 2-port calibrations are performed. Two full SOLT 2-port calibrations are performed on each port. Isolation is turned off during each 2-port calibration.
2. A test cable is attached to the first port, and a calibration is performed at the end of the cable and at the second port. The cable is moved to the second port and another calibration is performed. Using two calibrations helps to eliminate the unknown characteristics of the through cable.
3. Each calibration produces 12 error terms.
4. The error terms are used to determine the following characteristics: directivity, source match, load match, reflection tracking, and transmission tracking.

### If the Analyzer Fails this Test:

- If the analyzer fails tracking error terms only, perform [“Receiver Calibration Adjustment” on page 3-47](#) and repeat this test.
- Failure of any other error terms indicate a hardware failure. Refer to the appropriate error term discussion in [Chapter 8, “General Purpose Maintenance Procedures”](#) for a typical cause of failure. Refer to [Chapter 7, “Repair and Replacement Procedures,”](#) for instructions on replacing the suspected faulty component or assembly.

## System Crosstalk Test

**Function of the Test:** To measure the level of signal leakage between the analyzer's test ports.

**Specification Tested:** Test Port Input–Crosstalk

**Equipment Used:** A calibration kit and a test cable.

### Description of the Test:

1. The analyzer is tested in both directions at various frequency segments.
2. The analyzer sweep is set for the desired frequency and number of points at a 10 Hz IF bandwidth. The power level is set to the lesser of either the maximum specified power level for the driving port or the maximum input power level for the receiving port.
3. A test cable is connected between the driving and receiving ports.
4. The analyzer is set for a ratioed through measurement (S21 for example) with log magnitude display and a sweep is taken and stored to memory (MEM).
5. The trace is set to data divided by memory (DATA/MEM).
6. The test cable is removed and shorts are placed on both ports.
7. The average of 16 sweeps is taken.
8. The resultant log magnitude trace represents the system crosstalk in dB for the frequency range or segment tested.

### If the Analyzer Fails this Test:

- A failure of this test usually indicates one of the following:
  - a loose cable connection
  - degradation of signal isolation in the receivers
  - degradation of signal isolation on the A35 receiver motherboard
- Remove the covers from the analyzer and tighten all RF cable connections and tighten all screws on the receivers and repeat this test. Refer to [“Removing and Replacing the A31, A32, A33, and A34 Receiver Modules and A49 IF Multiplexer Board” on page 7-54](#) for instructions on how to remove the covers and for illustrations of the cable and screw locations.
- If the analyzer still fails this test, replace the receiver associated with the port that is failing and repeat this test. Refer to [“Removing and Replacing the A31, A32, A33, and A34 Receiver Modules and A49 IF Multiplexer Board” on page 7-54](#).
- If the analyzer still fails this test, replace the A35 receiver motherboard and repeat this test. Refer to [“Removing and Replacing the A35 Receiver Motherboard” on page 7-56](#).

## Dynamic Accuracy Test

**Function of the Test:** To measure the relative power linearity of the analyzer's receivers.

**Specification Tested:** Test Port Input–Dynamic Accuracy

**Equipment Used:** The dynamic accuracy test set (Z5623A Option H01), a power meter (E4418B or E4419B), power sensors, and two test cables.

### Description of the Test:

1. The analyzer's test ports are tested separately at a specific CW frequency and a reference power level of -20 dBm.
2. The analyzer's driving port is connected to the dynamic accuracy test set's source port and the analyzer's receiving port is connected to the dynamic accuracy test set's receiver port. A power sensor is connected to the dynamic accuracy test set's power meter port.
3. The dynamic accuracy test set is used to input a signal from the driving port on the analyzer. The input signal is routed through step attenuators to both the analyzer and a power sensor.
4. The analyzer source and the dynamic accuracy test set create power levels that are "deltas" from the reference power level of -20 dBm. Each delta is measured two ways: by the power sensor and by the analyzer's receiver under test.
5. The analyzer's power level into the port under test is set to the -20 dBm reference level.
6. The power level is measured with the power sensor: ( $P_{mr}$ ).
7. The power level is measured using the analyzer's receiver under test: ( $P_{pr}$ ).
8. The power level into the analyzer's port under test is stepped, in 5 dB steps, over the range of 0 to -120 dBm. Each power level represents a "delta" from the reference level.
9. At each step, the power level is measured using the power meter: ( $P_{md}$ ).
10. At each step, the power level is measured using the receiver under test: ( $P_{pd}$ ).
11. The power error in dB =  $(P_{mr}-P_{md})-(P_{pr}-P_{pd})$ .

### If the Analyzer Fails this Test:

- A failure of this test indicates a failure of one or more of the following assemblies.
  - A31 channel A receiver
  - A34 channel B receiver
  - A6 SPAM board
- Since all four receivers are identical, the channel A and channel B receivers can be swapped with the channel R1 and channel R2 receivers to determine if they are the cause of the failure. Refer to ["Removing and Replacing the A31, A32, A33, and A34 Receiver Modules and A49 IF Multiplexer Board"](#) on page 7-54. After swapping the receivers, repeat this test.
- If the analyzer still fails this test, replace the A6 SPAM board and repeat this test. Refer to ["Removing and Replacing the A6, A8, A9, and A10 Boards"](#) on page 7-18.

## Adjustments

These adjustments are firmware-driven tests that are used to fine-tune your analyzer for optimum response.

If multiple adjustments are to be performed, perform them in the order listed.

- “10 MHz Frequency Reference Adjustment” on page 3-39
- “3.8 GHz PMYO Frequency Adjustment” on page 3-40
- “LO Power Adjustment” on page 3-41
- “LO Offset Adjustment” on page 3-43
- “Source Calibration Adjustment” on page 3-45
- “Phase Lock IF Gain Adjustment” on page 3-46
- “Receiver Calibration Adjustment” on page 3-47

## 10 MHz Frequency Reference Adjustment

The 10 MHz frequency adjustment is used to adjust the frequency accuracy of the network analyzer's 10 MHz frequency reference on the A10 frequency reference board assembly.

### Equipment Used for the Frequency Adjustment at 10 MHz

Equipment Type	Models Used With	Model or Part Number	Alternate Model or Part Number
Cable, BNC, 50Ω, 24 inch	All	8120-1839	Any
Frequency counter	All	53151A Opt 001	Any <sup>a</sup>

- a. Must be capable of measuring a signal at 10 MHz.

### Procedure

**NOTE** The specification of frequency accuracy is  $\pm 1$  ppm. However, this test typically adjusts to  $\pm 0.01$  ppm.

1. Connect the equipment as shown in [Figure 3-17](#). Connect a GPIB cable between the network analyzer and the frequency counter.

**Figure 3-17 Setup for Adjustment of the 10 MHz Frequency Reference**

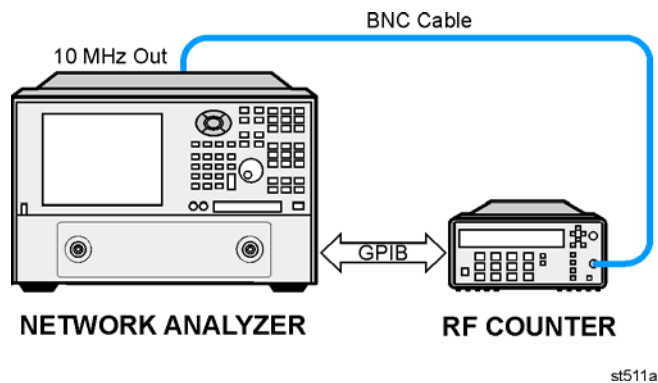

2. On the **System** menu, point to **Service, Adjustments**, and then click **10 MHz Freq Adjust**.
3. Ensure the GPIB settings are correct.
4. Click **Begin Adj**, and then follow the instructions as they are displayed.

### 3.8 GHz PMYO Frequency Adjustment

The 3.8 GHz adjustment is used to adjust the frequency accuracy of the network analyzer's 3.8 GHz permanent-magnet YIG oscillator (PMYO) on the A12 source 20.

#### Equipment used for the Frequency Adjustment at 3.8 GHz

Equipment Type	Models Used With	Model or Part Number	Alternate Model or Part Number
Spectrum analyzer	All	8565E	856xE <sup>a</sup>
RF Cable, 3.5 mm (f) to 3.5 mm (f)	E8362C	85131C	85131E
Adapter, 3.5 mm (m) to type-N (m)	E8362C	1250-1743	None
RF Cable, 2.4 mm (f) to 2.4 mm (f)	E8363C, E8364C	85133C	85133E
Adapter, 2.4 mm (m) to type-N (m)	E8363C, E8364C	11903A	None

a. Must be capable of measuring a signal at 3.8 GHz.

#### Procedure

1. Connect the equipment as shown in [Figure 3-18](#). Connect a GPIB cable between the network analyzer and the spectrum analyzer.

**Figure 3-18 Setup for Adjustment of the 3.8 GHz PMYO**

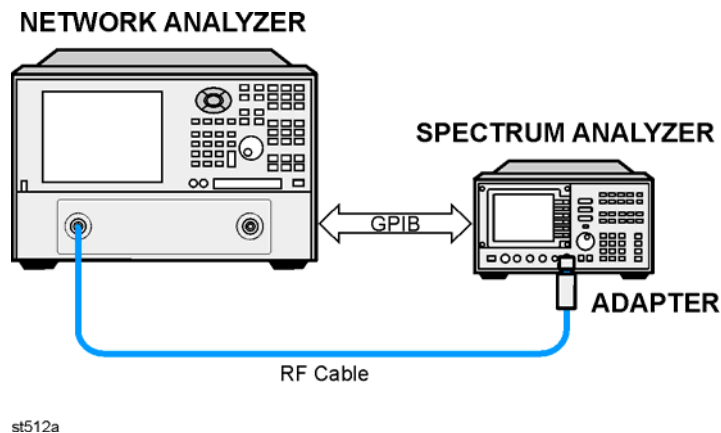

2. On the **System** menu, point to **Service, Adjustments**, and then click **3.8 GHz Freq Adjust**.
3. Ensure the GPIB settings are correct.
4. Click **Begin Adj**, and then follow the instructions as they are displayed.



## LO Power Adjustment

The LO power adjustment is used to adjust the power level of the LO signals from the A20 LO distribution assembly. This adjustment is done for only one LO output. The differences between each LO output is negligible; therefore, separate adjustments are not required.

### Equipment used for the LO Power Adjustment

Equipment Type	Models Used With	Model or Part Number	Alternate Model or Part Number
Power meter	All	E4418B/E4419B	E4418A/E4419A
Power sensor, 3.5 mm	E8362C	E4413A	8485A
Power sensor, 2.4 mm	E8363C, E8364C	8487A	None
Adapter, 2.4 mm (f) to 3.5 mm (m) <sup>a</sup>	E8363C, E8364C	11901D	None
5/16-inch, open-end torque wrench (set to 10 in-lbs)	All	N/A	N/A
1/4-inch, open-end wrench	All	N/A	N/A

a. Required only if using the 8487A power sensor.

### Procedure

1. Turn off the network analyzer and remove the power cable and other external cables from the rear panel.
2. Remove the outer cover. Refer to “Removing the Covers” on page 7-6.
3. Place the analyzer on its side to allow access to the bottom of the analyzer.
4. Connect the equipment as shown in Figure 3-19. Connect a GPIB cable between the analyzer and the power meter.
5. With a 5/16-inch open-end wrench, loosen W40 at the first converter (mixer).
6. At the junction of W40 and W14, place a 5/16-inch wrench on the W40 connector and a 1/4-inch wrench on the W14 connector. While holding the 1/4-in wrench to prevent W14 from rotating, disconnect W40 from W14 and move W40 aside.
7. Connect the power sensor to the end of W14, as shown in Figure 3-19.

**Figure 3-19 Setup for the LO Power Adjustment**

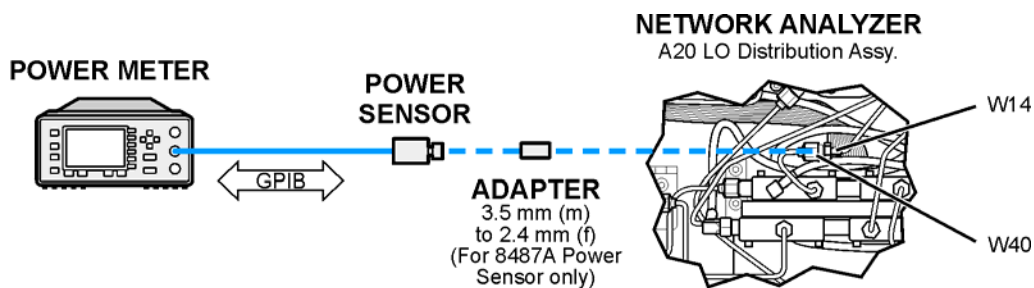

st510a

8. Reconnect the power and USB cables. Turn on the analyzer.
9. On the **System** menu, point to **Service, Adjustments**, and then click **LO Power Adjust**.
10. Ensure the GPIB settings are correct.
11. Click **Begin Adj**, and then follow the instructions as they are displayed.
12. Turn off the analyzer, disconnect the power cable, reconnect the semi-rigid cables, and replace the covers.

## LO Offset Adjustment

The LO power adjustment is used to adjust the power level of the LO signals from the A20 LO distribution assembly. This adjustment is done for only one LO output. The differences between each LO output is negligible; therefore, separate adjustments are not required.

### Equipment used for the LO Power Adjustment

Equipment Type	Model or Part Number	Alternate Model or Part Number
Power meter	E4418B/E4419B	E4418A/E4419A
Power sensor, 2.4 mm	8487A	E4413A <sup>a</sup>
Adapter, 3.5 mm (m) to 2.4 mm (f)	11901D	
Adapter, SMA (m) to SMA (f), right angle	1250-1249	Equivalent
5/16 inch, open-end torque wrench (set to 10 in-lbs)	8710-1765	N/A

a. The E4413A 3.5 mm power sensor may be used instead of the 8487A power sensor and 11901D adapter.

### Procedure

1. Turn off the network analyzer and remove the power cable and other external cables from the rear panel.
2. Remove the outer cover. Refer to “Removing the Covers” on page 7-6.
3. Connect a GPIB cable between the analyzer and the power meter.
4. Remove the semi-rigid cable connected to J3 LO OUT and the RECEIVER LO IN on the A13 frequency offset receiver assembly.
5. Connect the right angle adapter to A13 LO OUT connector.

**Figure 3-20 Setup for the LO Offset Adjustment**

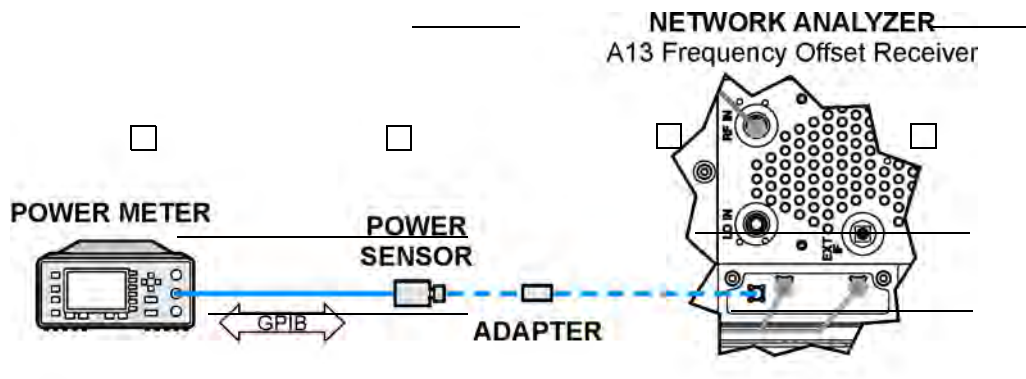

6. Connect the power sensor 8487A and the 11901D adapter or the E4413A power sensor to the end of the

right angle adapter as shown in [Figure 3-19 on page 3-41](#).

7. Reconnect the power and USB cables. Turn on the analyzer.
8. On the **System** menu, point to **Service, Adjustments**, and then click **LO Power Adjust**.
9. Ensure the GPIB settings are correct.
10. Click **Begin Adj**, and then follow the instructions as they are displayed.
11. Turn off the analyzer, disconnect the power cable, reconnect the semi-rigid cables, and replace the covers.

## Source Calibration Adjustment

The source calibration is used to adjust your network analyzer for a flat source power across its full frequency range. The differences between Port 1 and Port 2 are negligible; therefore, a Port 2 adjustment is not required.

### Equipment Used for the Source Calibration Adjustment

Equipment Type	Models Used With	Model or Part Number	Alternate Model or Part Number
Power meter	All	E4418B/E4419B	E4418A/E4419A
Power sensor, 3.5 mm	E8362C	E4413A	8485A
Adapter, 3.5 mm (f) to 3.5 mm (f)	E8362C	83059B	85052-60012
Power sensor, 2.4 mm	E8363C, E8364C	8487A	None
Adapter, 2.4 mm (f) to 2.4 mm (f)	E8363C, E8364C	11900B	85056-60007

### Procedure

1. Connect the equipment as shown in [Figure 3-21](#). Connect a GPIB cable between the network analyzer and the power meter.

**Figure 3-21 Setup for the Source Calibration Adjustment**

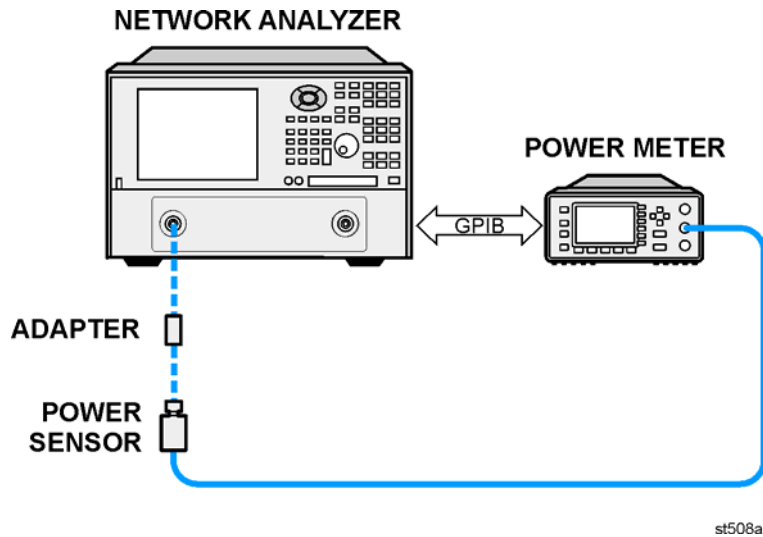

2. On the **System** menu, point to **Service, Adjustments**, and then click **Source Calibration**.
3. Ensure the GPIB settings are correct.
4. Click **Calibrate**, and then follow the instructions as they are displayed.

## Phase Lock IF Gain Adjustment

The phase lock IF gain adjustment is used to adjust the phase-lock loop IF signal amplitude to a constant level across the analyzer's full frequency range:

1. No additional equipment is required for this adjustment.
2. No connections to the test ports are required for this adjustment.

### Procedure

1. On the **System** menu, point to **Service, Adjustments**, and then click **IF Gain Adjustment**.
2. If appropriate, select any special test options installed. Otherwise, leave this selection at **None**. The **Advanced** screen is for factory use only.
3. Click **Begin Adj.**
4. The adjustment takes approximately one minute to complete.

## Receiver Calibration Adjustment

The receiver calibration is used to adjust the network analyzer receivers for a flat response across its full frequency range:

1. A power meter/sensor is connected to Port 1, as shown in [Figure 3-22](#), to establish a reference for flatness.
2. A cable is inserted between the power sensor and the test port, as shown in [Figure 3-23](#), to establish a reference for the cable.
3. The same cable is connected between the two test ports, as shown in [Figure 3-24](#), and a signal from Port 1 is used to adjust the “B” receiver at Port 2.

The adjustment is repeated using a signal from Port 2 to adjust the “A” receiver at Port 1.

Data obtained during this adjustment are stored in the mxcalfile\_pxx files on the hard disk drive (where xx is a 1 or 2 digit number). The data are used in subsequent measurements.

If the hard disk drive is replaced, these mxcalfile\_pxx files will be lost. Therefore, they should be backed up (saved on a USB drive) so that they can be restored. If using multiple disk drives (e.g. classified and general usage), then these files must be replaced on each individual disk drive.

These files can be recreated by performing another receiver calibration adjustment.

### Equipment Used for the Receiver Calibration Adjustment

Equipment Type	Models Used With	Model or Part Number	Alternate Model Part Number
Power meter	All	E4418B/E4419B	E4418A/E4419A
Power sensor, 3.5 mm	E8362C	E4413A	8485A
Adapter, 3.5 mm (f) to 3.5 mm (f)	E8362C	83059B	85052-60012
RF Cable, 3.5 mm (f) to 3.5 mm (f)	E8362C	85131C	85131E
Power sensor, 2.4 mm	E8363C, E8364C	8487A	None
Adapter, 2.4 mm (f) to 2.4 mm (f)	E8363C, E8364C	11900B	85056-60007
RF Cable, 2.4 mm (f) to 2.4 mm (f)	E8363C, E8364C	85133C	85133E

### Procedure

1. Connect the equipment as shown in [Figure 3-22](#). Connect a GPIB cable between the network analyzer and the power meter.
2. On the **System** menu, point to **Service, Adjustments**, and then click **Receiver Calibration**.
3. Ensure the GPIB settings are correct.
4. Click **Calibrate**, and then follow the instructions as they are displayed.

**Figure 3-22 Setup 1 for the Receiver Calibration Adjustment**

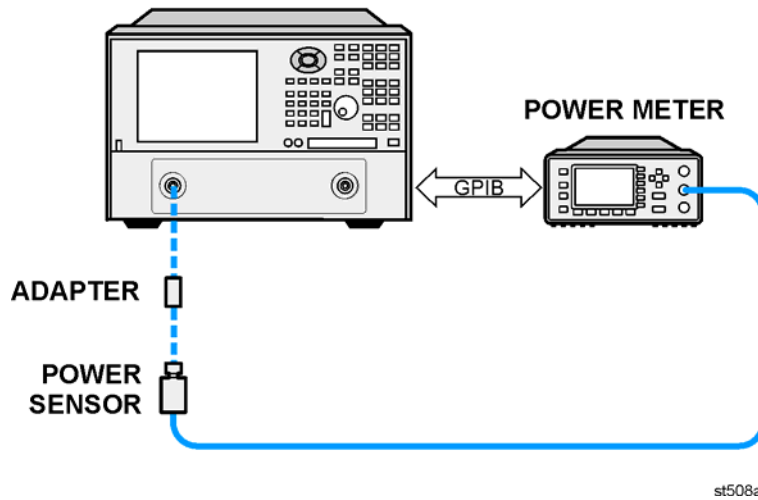

**Figure 3-23 Setup 2 for the Receiver Calibration Adjustment**

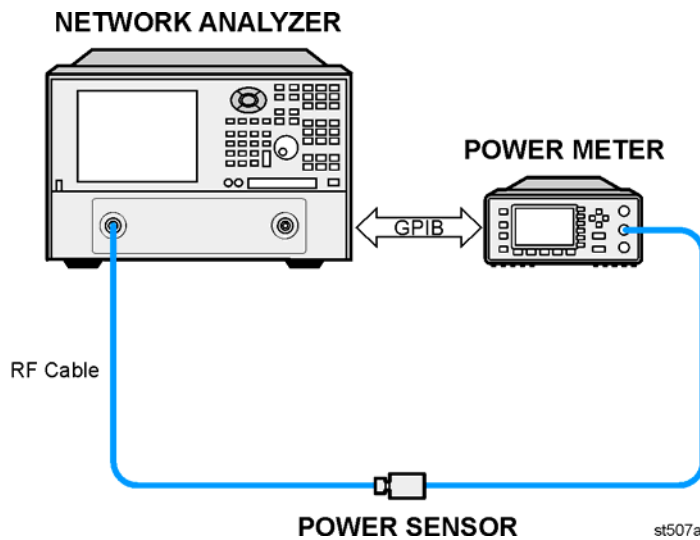

**Figure 3-24 Setup 3 for the Receiver Calibration Adjustment**

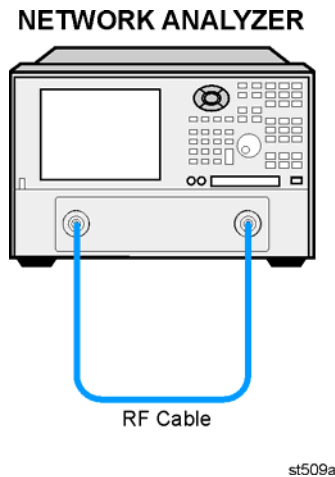



---

## **4 Troubleshooting**

## Information in This Chapter

The information in this chapter helps you:

- Identify the portion of the analyzer at fault.
- Locate the specific troubleshooting procedure to identify the assembly or peripheral at fault.

The sections in this chapter are arranged in a logical troubleshooting order. The following table lists the sections and a brief summary of what to look for in that section.

### Chapter Four at-a-Glance

Section Title	Summary of Content	Start Page
<a href="#">Getting Started with Troubleshooting</a>	A starting point to begin troubleshooting.	<a href="#">Page 4-4</a>
<a href="#">Power Up Troubleshooting</a>	Power-up problems: <ul style="list-style-type: none"> <li>• Power supply problems</li> <li>• LCD problems</li> <li>• Bootup for the network analyzer interface</li> </ul>	<a href="#">Page 4-6</a>
<a href="#">Front Panel Troubleshooting</a>	Problems occurring after the network analyzer interface is loaded: <ul style="list-style-type: none"> <li>• Does the display color appear correct?</li> <li>• Do the front panel keys function properly?</li> <li>• Do the front panel USB connectors function properly?</li> </ul>	<a href="#">Page 4-12</a>
<a href="#">Rear Panel Troubleshooting</a>	Problems associated with the rear panel interconnects.  <i>The data found at these rear panel interconnects can be used to troubleshoot the CPU board.</i>	<a href="#">Page 4-17</a>
<a href="#">Measurement System Troubleshooting</a>	Problems with the measurement portion of the analyzer. <ul style="list-style-type: none"> <li>• Checking the A, B, R1, and R2 signals.</li> <li>• Checking the source group.</li> <li>• Checking the receiver group.</li> <li>• Checking the signal separation group.</li> <li>• Checking the frequency offset group (Option 080).</li> </ul>	<a href="#">Page 4-24</a>
<a href="#">Instrument Block Diagrams</a>	Block diagrams for the analyzer including Option UNL and Option 014.	<a href="#">Page 4-49</a>

---

## Protect Against Electrostatic Discharge (ESD)

This is important. If not properly protected against, electrostatic discharge can seriously damage your analyzer, resulting in costly repair.

---

**CAUTION** To reduce the chance of electrostatic discharge, follow all of the recommendations outlined in [“Electrostatic Discharge Protection”](#) on page 1-6, for all of the procedures in this chapter.

---

---

## Assembly Replacement Sequence

After identifying the problem requiring an assembly to be replaced, follow these steps:

- Step 1.** Order a replacement assembly. Refer to [Chapter 6, “Replaceable Parts.”](#)
- Step 2.** Replace the faulty assembly and determine what adjustments are necessary. Refer to [Chapter 7, “Repair and Replacement Procedures.”](#)
- Step 3.** Perform the necessary adjustments. Refer to [Chapter 3, “Tests and Adjustments.”](#)
- Step 4.** Perform the necessary performance tests. Refer to [Chapter 3, “Tests and Adjustments.”](#)

---

## Getting Started with Troubleshooting

Where you begin troubleshooting depends upon the symptoms of the failure. Start by checking the basics as outlined in the following section. Also review the flowchart in [Figure 4-1 on page 4-5](#). You should then be able to determine where in the troubleshooting procedure to begin, to locate the failed assembly.

### Check the Basics

A problem can often be solved by repeating the procedure you were following when the problem occurred. Before calling Agilent Technologies or returning the instrument for service, please perform the following checks:

1. Is there power at the mains receptacle? If not, correct this situation and proceed.
2. Is the instrument turned on? Check to see if the front panel line switch glows. This indicates the power supply is on. If the front panel line switch is on but the power supply does not appear to be on, go to [“Power Up Troubleshooting” on page 4-6](#).
3. Is the Windows® operating system running? If not, refer to [“Operating System Recovery” in Chapter 8](#) for instructions.
4. If other equipment, cables, and connectors are being used with the instrument, make sure they are clean, connected properly and operating correctly.
5. If the PNA has Option 014, verify that the cables are connected properly.
6. Review the procedure for the measurement being performed when the problem appeared. Are all the settings correct? If not, correct them.
7. If the instrument is not functioning as expected, return the unit to a known state by pressing the **Preset** key.
8. Is the measurement being performed, and the results that are expected, within the specifications and capabilities of the instrument? Refer to the embedded help in the analyzer for instrument specifications.
9. If the problem is thought to be due to firmware, check to see if the instrument has the latest firmware before starting the troubleshooting procedure. Refer to [“Firmware Upgrades” in Chapter 8](#) for instructions.
10. If the necessary test equipment is available, perform the operator’s check and system verification in [Chapter 3, “Tests and Adjustments.”](#)

## Troubleshooting Organization

Follow the flowgraph in [Figure 4-1](#) to help direct you to the correct section for troubleshooting the analyzer.

**Figure 4-1** Troubleshooting Organization Flowchart

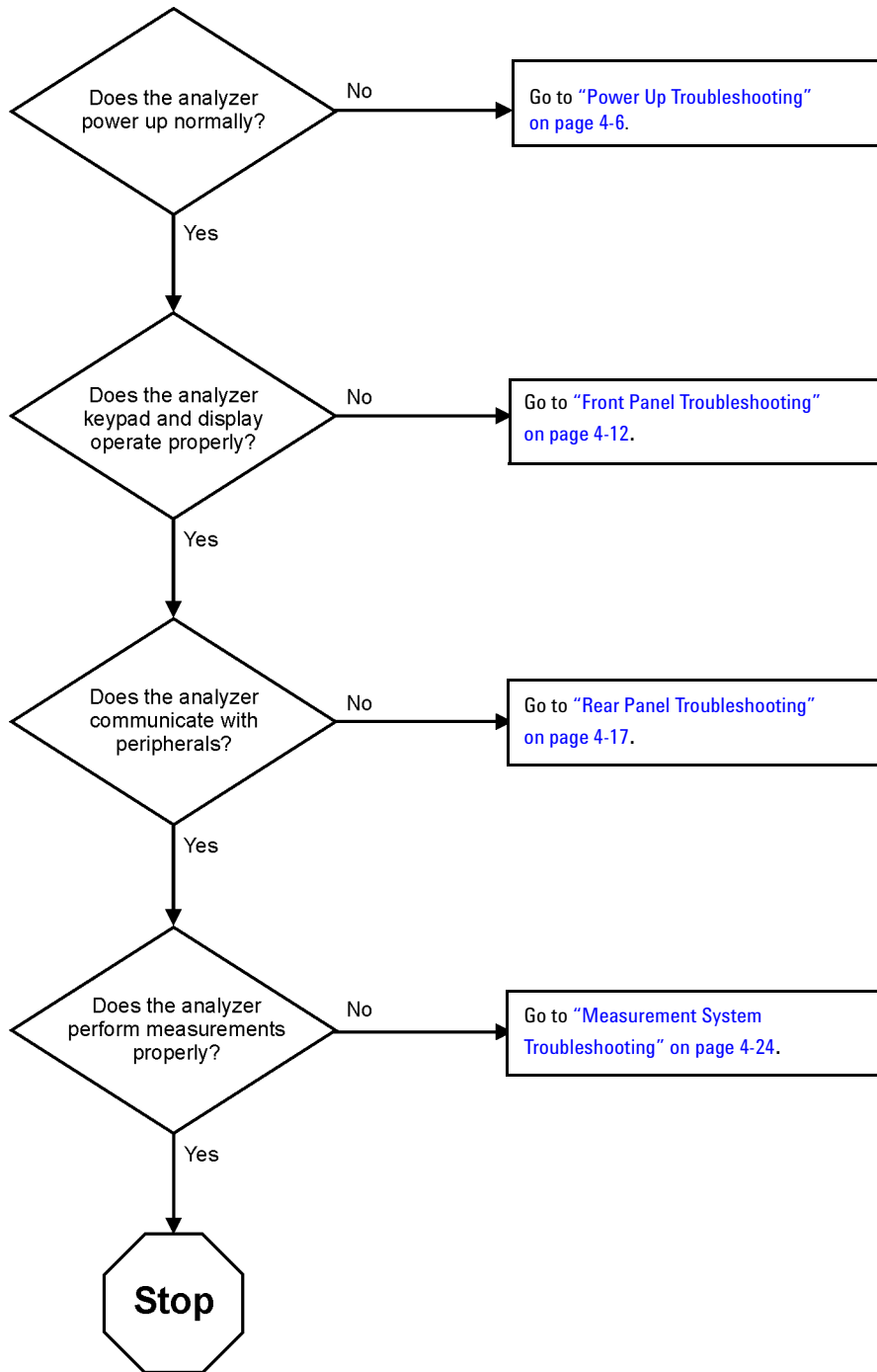

sc867b

---

## Power Up Troubleshooting

---

**WARNING** Immediately unplug the instrument from the ac power line if the unit shows any of the following symptoms:

- **Smoke, arcing, or unusual noise from inside the analyzer.**
  - **A circuit breaker or fuse on the main ac power line opens.**
- 

Check your network analyzer for evidence that it is powering up correctly. Perform the following steps and make sure that the analyzer is displaying correct behavior as noted in the following steps.

**Step 1.** Disconnect all peripherals and plug in the network analyzer. Before the analyzer is powered on, the line switch should glow yellow and no other lights should be on.

**Step 2.** Turn on the network analyzer.

- The line switch should glow green.
- The fans should be audible.
- The display should flash and then show the hardware boot-up sequence. This process checks the RAM and communication with the hard disk drive. These checks return an error message if a problem is detected.
- The Windows operating system should start.
- The network analyzer measurement interface should open with an  $S_{11}$  measurement displayed.

**Step 3.** If the analyzer powers up correctly, continue troubleshooting with [“Front Panel Troubleshooting” on page 4-12](#).

**Step 4.** If the analyzer does not power up correctly, follow these troubleshooting steps:

- If the line switch does not glow or the fans are not operating (audible), go to [“Power Supply Check” on page 4-7](#).
- If you cannot hear the fans operating, go to [“If the Fans Are Not Operating” on page 4-11](#).
- If the line switch glows green and the fans are operating (audible), but the display remains dark, go to [“Front Panel Troubleshooting” on page 4-12](#).
- If the instrument appears to abort the network analyzer measurement interface process, contact Agilent. Refer to [“Contacting Agilent” on page 2-12](#).

## Power Supply Check

---

**NOTE** There are no fuses to replace within the power supply. If you determine that the power supply is the failed assembly, replace the power supply.

---

A catastrophic failure in the power supply can be determined by observing the line switch:

1. Ensure that the instrument is plugged in with the power switch in the standby position (power not switched on). Verify that the line switch glows yellow. A line switch that glows yellow indicates that the +15 VDC line (P15 STB) is providing enough voltage to light the LED. (The actual voltage may not be +15 VDC.)
2. Turn on the instrument power and verify that the line switch glows. When the line switch glows, it is an indication that the power supply has received an "ON" command and that the +5.2 VDC supply can supply enough current to light, at least, these lamps.

If these supply voltages are missing, it is likely that the problem is either a defective A4 power supply, or another assembly is loading down the A4 power supply. Continue with ["If All Supply Voltages Are Missing" on page 4-9](#), to determine the cause of the problem.

If the line switch is lit correctly, the power supply has not suffered a catastrophic failure; however, the power supply could still be at fault. Continue with the next section to measure the individual voltage supplies.

### Measure the Individual Voltage Supplies

**WARNING** The instrument contains potentially hazardous voltages. Refer to the safety symbols provided on the instrument and in [“General Safety Considerations” on page 1-3](#) before operating the unit with the cover removed. Make sure that the safety instructions are strictly followed. Failure to do so can result in personal injury or loss of life.

To measure the power supply voltages, it is necessary to remove the instrument’s outer and inner covers. Refer to [“Removing the Covers” on page 7-6](#) for removal procedures. Use the E8356-60021 extender board to measure the individual power supply voltages. Insert the extender board into an empty slot next to the A6 signal processing ADC module (SPAM) board.

**NOTE** If any one individual voltage supply from the A4 power supply develops an over-voltage or over-current problem, all supplies are affected. The supply goes into a “burp” mode characterized by the supplies cycling on and off at a low voltage level. The cause of the over-voltage or over-current condition can be the A4 power supply itself, or any assembly to which the A4 power supply provides voltage. To isolate the cause of “burp” mode, continue to the assembly removal process as described in the section titled [“If All Supply Voltages Are Missing” on page 4-9](#).

On the extender board, measure the power supply voltages using a digital multi-meter. Refer to [Figure 4-2](#) for the power supply test points on the extender board. Use the point marked as “GND” for the ground connection. Refer to [Table 4-1 on page 4-9](#) for the correct voltages.

**Figure 4-2 E8356-60021 Synthesizer/Reference Extender Measurement Points**

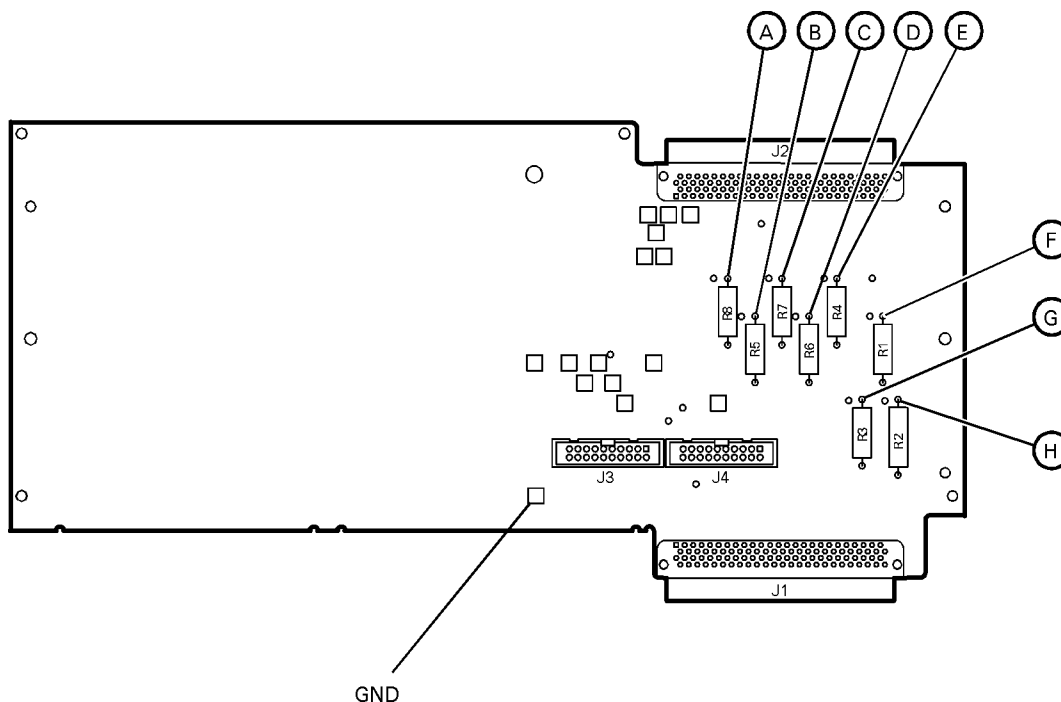

sc844a



**Table 4-1 Extender Board Measurement Points**

Measurement Location	Signal Description	Test Equipment Used <sup>1</sup>	Expected Level (Vdc)	Approximate Resistance (W)
A	+5V power supply	DMM	+5.0	285
B	-15V power supply	DMM	-15.0	12.7 k
C	-5V power supply	DMM	-5.0	7.2 k
D	+9V power supply	DMM	+9.0	4.0 k
E	+15V power supply	DMM	+15.0	3.0 k
F	+15V power supply	DMM	+15.0	2.8 k
G	+22V power supply	DMM	+22.0	890
H	+32V power supply	DMM	+32.0	2.6 k

1. DMM = Digital multi-meter

**If All Supply Voltages Are Present**

If all of the supplies have measured within tolerances, and the instrument still is not functioning properly, refer to [“Rear Panel Troubleshooting” on page 4-17](#).

**If All Supply Voltages Are Missing**

---

**WARNING**     **Disconnect the line-power cord before removing any assembly. Procedures described in this document may be performed with power supplied to the product while protective covers are removed. Energy available at many points may, if contacted, result in personal injury or loss of life.**

---

It is necessary to sequentially remove all of the assemblies, taking care to disconnect the line-power cord before each removal, and then to measure the supply voltages after each removal.

If the missing supply voltages return to a “power on” condition after removal of an assembly, suspect that assembly as being defective.

Remove the network analyzer assemblies in the order specified in the following steps (refer to [Chapter 7](#) for removal instructions).

1. Unplug the test set motherboard cable from the A16 test set motherboard. Refer to [“Removing and Replacing the A16 Test Set Motherboard” on page 7-32](#).
2. Unplug the front panel interface cable from the A3 front panel interface board. Refer to [“Removing and Replacing the Front Panel Assembly” on page 7-10](#).
3. Remove the A6 SPAM board. Refer to [“Removing and Replacing the A6, A8, A9, and A10 Boards” on page 7-18](#).

4. Remove the A8 fractional-N synthesizer board. Refer to [“Removing and Replacing the A6, A8, A9, and A10 Boards” on page 7-18.](#)
5. Remove the A9 fractional-N synthesizer board (option 080). Refer to [“Removing and Replacing the A6, A8, A9, and A10 Boards” on page 7-18.](#)
6. Remove the A10 frequency reference board. Refer to [“Removing and Replacing the A6, A8, A9, and A10 Boards” on page 7-18.](#)
7. Remove the A11 phase lock board. Refer to [“Removing and Replacing the A11 Phase Lock Board” on page 7-20.](#)
8. Unplug the A31 hard disk drive from the A15 CPU board. Refer to [“Removing and Replacing the A41 Hard Disk Drive \(HDD\)” on page 7-62.](#)

The minimum required assemblies to power up the analyzer are:

- A4 power supply
- A14 system motherboard
- A15 CPU board

To further isolate the failure in the three remaining assemblies, measure the resistance on the extender board (with the power turned off) from the power supply test points to “GND”. Refer to [Figure 4-2 on page 4-8](#) for the location of the measurement points. The resistances should be as shown in [Table 4-1 on page 4-9.](#)

---

**NOTE** Make sure that the only assemblies plugged in are the three minimum required assemblies listed above.

---

Check for shorts (zero  $\Omega$ ) or very low resistance (approximately 1  $\Omega$ ). If a short or low resistance is measured, isolate each of the remaining three boards in the following order, and recheck the shorted test point after each board is removed. Note that the resistance may be different from that listed in the table, but you should be able to determine if the shorted condition has changed.

Isolate the remaining three assemblies:

- remove the A15 CPU board
- remove the A4 power supply
- This leaves only the A14 system motherboard installed. If the measurements are still incorrect, this is the suspected faulty assembly.

### If the Fans Are Not Operating

**CAUTION** The power supply may be in thermal shutdown if the instrument has been operating without the fans running. Allow the instrument to cool down before troubleshooting.

If all three fans are not operating, suspect a power supply problem or a defective A14 system motherboard. Refer to [“Power Supply Check” on page 4-7](#) to check the individual supplies. If the supplies are within specifications, the most probable cause is a defective A14 system motherboard. Refer to [“Removing and Replacing the A14 System Motherboard” on page 7-26](#).

If only one or two fans are not functioning, and the power supplies are within specifications, suspect the A14 system motherboard or a defective fan. Perform the following procedure.

1. Remove the front panel assembly from the instrument. Refer to [“Removing and Replacing the Front Panel Assembly” on page 7-10](#).
2. Refer to [Figure 4-3](#). Measure the fan voltages at J1, J3, and J4 on the A14 system motherboard.

**Figure 4-3 Fan Voltages**

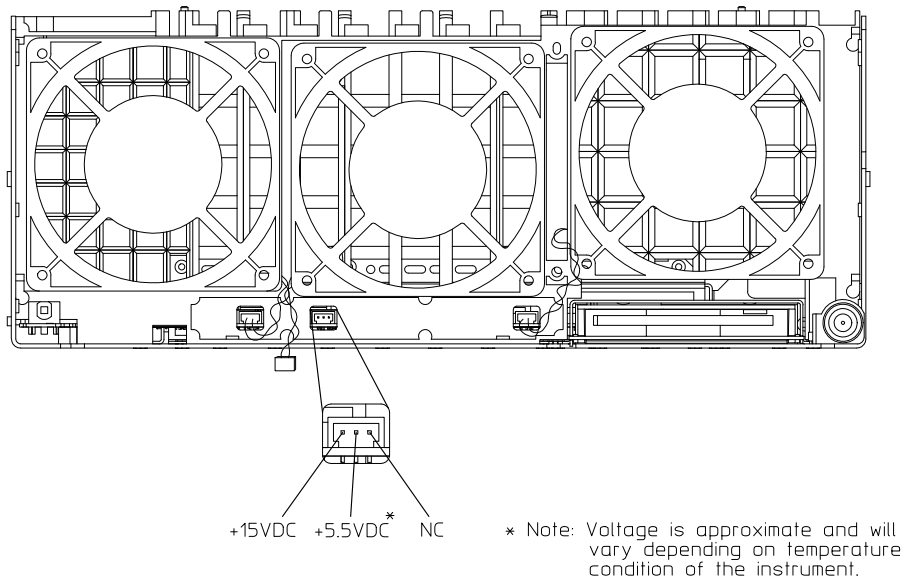

sa867a

3. If the correct voltage is present and the fan connector is in good mechanical condition, suspect a defective fan. Refer to [“Removing and Replacing the Midweb and the B1 Fan” on page 7-76](#).
4. If the voltage is not present, suspect a defective A14 system motherboard. Refer to [“Removing and Replacing the A14 System Motherboard” on page 7-26](#).

---

## Front Panel Troubleshooting

The front panel assembly consists of the A1 keypad, the A2 display assembly, the A3 front panel interface board, the touchscreen and touchscreen controller board, the inverter board, and the USB board. The following tests verify the operation of the front panel assembly when the analyzer is in the measurement mode. If the instrument fails to power up correctly, or it is difficult to verify due to a faulty display, refer to [“Power Up Troubleshooting” on page 4-6](#).

Refer to the following sections to verify the operation of the noted assemblies.

- [“Front Panel Keypad and RPG Test” on page 4-13](#)
- [“A2 Display Test” on page 4-15](#)
- [“Checking the USB Board” on page 4-16](#)
- [“A3 Front Panel Interface Board” on page 4-16](#)

If all assemblies are working correctly, continue troubleshooting with [“Rear Panel Troubleshooting” on page 4-17](#).

## Front Panel Keypad and RPG Test

Test the front panel keypad by running the front panel test. To run the front panel test, perform the following:

Press UTILITY **System** , then **Service** , then **More** , then **Front Panel Test** .

A **Front Panel Key Test Utility** dialog box will be displayed, as shown in [Figure 4-4](#).

**Figure 4-4** Front Panel Key Test Utility Dialog Box

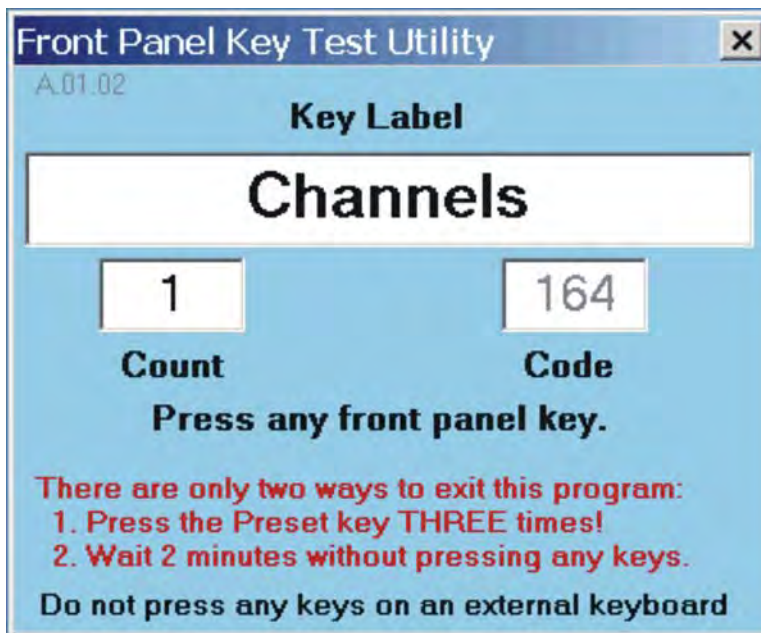

n5242\_001\_403

### Checking the Front Panel Keys

To check the front panel keys, push each key and compare the name in the Key Label box to the name physically labeled on the key cap. These names are also in [Table 4-2](#) below.

- If all the key names are correct, then the front panel keypad is working. If some of the keys are not working, suspect a faulty keypad. To replace the keypad, refer to [“Replacing the A1 Keypad Assembly” on page 7-14.](#)
- If none of the keys are working correctly, suspect a faulty A3 front panel interface board. To replace the A3 front panel interface board, refer to [“Replacing the A3 Front Panel Interface Board” on page 7-14.](#)

**Table 4-2 Front Panel Keyboard Key Names**

TRACE/CHAN Keys	RESPONSE Keys	ENTRY Keys	ENTRY Keys (Cont'd)
Trace 1	Meas	OK	k/m
Trace 2	Format	Cancel	Enter Off
Trace 3	Scale	Help	. (decimal point)
Trace 4	Display	Bk Sp	+/-
Traces	Avg	0	<b>STIMULUS Keys</b>
Channel	Cal	1	Freq
<b>Navigation Keys</b>	<b>MARKER/ ANALYSIS Keys</b>	2	Power
←	Marker	3	Sweep
→	Search	4	Trigger
↑	Memory	5	<b>UTILITY Keys</b>
↓	Analysis	6	Save
Click		7	Print
		8	Macro
		9	Recall
		G/n	System
		M/u	Preset

### Checking the RPG (Front Panel Knob)

To check the RPG knob:

1. Press the UTILITY **Preset** key.
2. Rotate the knob and check for a fluid movement of numbers on the analyzer display.
  - If the movement of numbers is not smooth or no numbers appear at all, suspect a faulty A1 front panel interface board. To replace the A3 front panel interface board, refer to [“Replacing the A3 Front Panel Interface Board” on page 7-14.](#)

### A2 Display Test

The display should be bright with all annotations and text readable. The display test allows you to check for non-functioning pixels and other problems.

---

**NOTE** If the display is dim or dark, refer to [“Front Panel Troubleshooting” on page 4-12.](#)

---

### What Is a Damaged Pixel?

A pixel is a picture element that combines to create the image on the display. A pixel is about the size of a small pin point.

A damaged pixel is:

- A pixel that has a constant blue, green, or red appearance that will not change, or
- a pixel that has a constant black appearance that will not change.

### How to Run the Display Test

To run the display test, perform the following:

Press UTILITY **System**, then **Service**, then **More**, then **Display Test**.

A multi-color screen is displayed. Be prepared to look for the symptoms described in [“How to Identify a Faulty Display.”](#) Follow the instructions on the screen.

### How to Identify a Faulty Display

A display is considered faulty if:

- More than 0.002% of the total pixels have a constant blue, green, red, or black appearance that will not change.
- Three or more consecutive pixels have a constant blue, green, red, or black appearance that will not change.
- If the A2 display assembly is determined to be faulty, replace it. Refer to [“Replacing the A2 Display Assembly” on page 7-13.](#)

## Checking the USB Board

To verify proper operation of the USB board:

- Connect a known good USB device, such as a USB mouse, to a front panel USB port.
- Wait 15 seconds for the analyzer to verify the device connection, and then check the operation of the USB device.
- If the device performs correctly, the USB board is functioning properly.
- If the device does not perform correctly, the USB board is faulty. Refer to [“Replacing the USB Connector Board” on page 7-14](#).

## A3 Front Panel Interface Board

This assembly performs the following functions:

- It routes USB signals between the front-panel USB connector and the A15 CPU board.
- The speaker produces the audio output from signals supplied by the A15 CPU board.
- It routes key pad commands from the keypad to the A15 CPU board.
- It routes display signals from the A15 CPU board to the A2 display assembly.

### Checking the Speaker

If no audio is heard:

- Verify that the volume is set correctly and the proper sound driver is loaded; do the following:
  - Press UTILITY **System**, then **Configure**, then **Control Panel...**.
- Click on the **Sounds and Audio Devices** entry. Follow the normal Windows procedure to check the sound drivers and volume. If the audio is still not heard, suspect a faulty speaker. Refer to [“Replacing the A3 Front Panel Interface Board” on page 7-14](#).

### Checking the Operation of the Key Pad Commands

To verify the key pad functionality, refer to [“Front Panel Keypad and RPG Test” on page 4-13](#).

### Checking the Display

To verify the display functionality, refer to [“A2 Display Test” on page 4-15](#).



---

## Rear Panel Troubleshooting

Each rear panel connector is associated with a hardware group in the analyzer. You can use the data at these rear panel connectors to help troubleshoot these hardware groups in addition to testing the connectors.

The connectors discussed in this section are:

- USB
- SERIAL (RS-232)
- PARALLEL (1284-C)
- VGA
- GPIB
- LAN

### Checking the USB Ports

---

**NOTE** The rear panel contains five USB ports; one “stand-alone USB port” on the CPU board and a “group-of-four” connected to a separate hub.

---

To verify proper operation of any USB port:

- Connect a known good USB device, such as a USB mouse.
- Wait 15 seconds for the analyzer to verify the device connection, and then check the operation of the USB device.
- If the device performs correctly, the USB port is functioning properly.
- If the device does not perform correctly, remove the non-working USB device, wait 15 seconds, and then reconnect the device to the USB port.
- If the device still does not perform correctly, remove the USB device and connect it to the front panel USB.

---

**NOTE** If the front panel USB port does not work, refer to [“A3 Front Panel Interface Board” on page 4-16](#).

---

- If the USB device has been verified to work on the front panel but *not* on the stand-alone USB port:
  - Then the A15 CPU board is faulty. Refer to [“Removing and Replacing the A15 CPU Board” on page 7-28](#).
- If the USB device has been verified to work on the front panel but not on one of the “group-of-four” USB ports:
  - Then the rear panel hub is faulty. Refer to [“Top Assemblies, All Options Including 080” on page 6-18](#) for replacing the rear panel hub board (part number E8356-60202).

## Checking the SERIAL (RS-232), PARALLEL (1284-C), or VGA Port

To verify the proper operation of the SERIAL, PARALLEL, or VGA port:

- Connect a known good serial, parallel, or VGA peripheral device.
- Wait 15 seconds for the analyzer to verify the device connection, and then check the operation of the peripheral device.
- If the peripheral device performs correctly, the port is functioning properly.
- If the peripheral device does not function properly, the A15 CPU board is faulty. Refer to [“Removing and Replacing the A15 CPU Board” on page 7-28](#).

## Checking the GPIB Port

The network analyzer uses a National Instruments 488.2 GPIB controller and associated driver software. This software includes a test utility which scans the GPIB bus and returns the status of all the connected peripherals.

To run the test utility software and check the GPIB status:

1. Connect a known good peripheral to the analyzer using a known good GPIB cable.
2. On the **System** menu, point to **Configure**, and then click **SCPI/GPIB**. A **SCPI/GPIB** dialog box is displayed.
3. In the **GPIB** block, click **System Controller** to establish the analyzer as a controller. Wait for the analyzer to configure, and then click **OK**.
4. On the **System** menu, click **Windows Taskbar** to open the **Start Menu** window.
5. On the **Start Menu** window, point to **Programs, National Instruments NI-488.2**, and then click **Explore GPIB** to open the **Measurement & Automation** window.
6. On the left side of the **Measurement & Automation** window under folders:
  - a. Click the plus sign to expand the **Measurement & Automation** folder.
  - b. Click the plus sign to expand the **Devices and Interfaces** folder.
  - c. Right click **GPIB0 (AT-GPIB/TNT)** to open a submenu.
7. On the submenu, click **Scan for Instruments** to run the test.
8. The state of all the peripherals found on the bus is returned.
9. If problems are detected, check the connections of all GPIB cables, and check all the GPIB addresses of the instruments on the bus.

---

### NOTE

#### Address Information

- Each device must have its own unique address.
- The network analyzer’s default GPIB address in the controller mode is 21.
- The address set on each device must match the one recognized by the analyzer (and displayed).

Refer to the manual of the peripheral to read or change its address.

---

### **Troubleshooting Systems with Controllers**

Passing the preceding test indicates that the analyzer's peripheral functions are operating normally. Therefore, if the analyzer has not been operating properly with an external controller, check the following:

- The GPIB interface hardware is incorrectly installed or not operational. (Refer to the embedded help in your analyzer.)
- The programming syntax is incorrect. (Refer to the embedded help in your analyzer.)

## LAN Troubleshooting

Problems with the Local Area Network (LAN) can be difficult to solve. Software and protocol problems can make it difficult to determine whether the analyzer's hardware is working properly, or if there is a problem with the LAN or cabling.

The purpose of this section is to determine if the analyzer's hardware is functioning properly. While the turn-on self-test verifies some LAN hardware functionality, it is limited to internal testing only. Incorrect IP addresses will prevent proper operation. Improper subnet masks may allow only one-way communication, while improper gateway addresses may exclude outside LAN access.

### Ping Command

The analyzer has the built-in capability of performing a “ping” operation. Ping will request the analyzer to send a few bytes of information to a specific LAN device. That device will then signal the analyzer that it has received the information. The analyzer computes the approximate round trip time of the communication cycle and displays it. For a full test of two-way communications, a ping test should be performed in two directions.

- **First:** you should ping from the analyzer to the local area network.
- **Second:** you should ping from the local area network to the analyzer.

---

**NOTE** In the second case, any other network device capable of sending a ping command could be used, assuming it is connected to the same network. This could be a computer or even another analyzer.

---

### How to Ping from the Analyzer to the Local Area Network (LAN)

Follow the steps below to verify proper LAN operation (assuming you have a functioning LAN). If no network LAN is available, see [“Testing Between Two Analyzers” on page 4-21](#).

1. Make sure the IP address on the analyzer is set properly and that it is unique. If unsure how to check the IP address, refer to the embedded help in the analyzer.
2. Make sure the subnet mask is 0.0.0.0. If not, note the current setting (to allow setting it back later) and then set it to 0.0.0.0.
3. Find and note the IP address of another working LAN device on the same network. Make sure this device is turned on, connected, and is functioning properly.
4. To ping the network device:
  - a. On the **System** menu, click **Windows Taskbar**.
  - b. On the **Windows Taskbar** menu, point to **Programs, Accessories**, and then click **Command Prompt**.
  - c. The command prompt window is displayed.
  - d. At the prompt, type ping xxx.xxx.xxx.xxx<sup>1</sup> and press **Enter** on the front panel or keyboard. Refer to Step 5 for the results of a successful ping.

---

1. The letters x represent the IP address of the other device on the network.

5. The analyzer attempts four cycles of communications with the indicated LAN device.
  - It displays the time it took to complete each cycle.
  - Each cycle times-out after one second if no communication is established and the message, Request timed out, is displayed.
  - It is common for the first of the four cycles to time-out even though subsequent cycles pass.
  - See below for an example output of a successful ping.

```
C:>ping 141.121.69.162
```

```
Pinging 141.121.69.162 with 32 bytes of data:  
Reply from 141.121.69.162: bytes=32 time<10ms TTL=127  
Reply from 141.121.69.162: bytes=32 time<10ms TTL=127  
Reply from 141.121.69.162: bytes=32 time<10ms TTL=127  
Reply from 141.121.69.162: bytes=32 time<10ms TTL=127  
Ping statistics for 141.121.69.162:
```

```
Packets: Sent = 4, Received = 4, lost = 0 <0% loss>.
```

```
Approximate round trip times in milli-seconds:
```

```
Minimum = 0ms, Maximum = 0ms, Average = 0ms
```

6. The above message verifies that one way communication from the analyzer to the network has been established
7. If the subnet mask was changed in step 2, set it back at this time.

### How to Ping from the Local Area Network (LAN) to the Analyzer

Reverse communication should also be verified. Determining this, though, is dependent upon your network setup and software. Generally, you need to issue a ping command using the IP address of the analyzer to be tested. For example, using Windows 95, 98, 2000 and while at a DOS prompt, type in ping xxx.xxx.xxx.xxx<sup>1</sup>. Then press **Enter** on the front panel or keyboard. If full communication can be established, then the computer display shows the cycle time for each of four cycle attempts (similar to that in step 5). Other software may behave somewhat differently, but basically the same.

If the analyzer can talk to the network, but the network can not talk to the analyzer, then the computer or device used from the network may have a subnet mask that excludes communication with the IP address chosen for the analyzer. Any subnet mask other than 0.0.0.0 will exclude operation from some addresses. Changing the subnet mask of a computer or other device should only be attempted by a qualified network administrator. Failure to communicate due to a subnet mask incompatibility does not indicate any failure of the analyzer.

If the analyzer fails to ping in either direction, and assuming the subnet masks are set properly, then the fault must be isolated to the analyzer or to the network. Contact a qualified network administrator.

### Testing Between Two Analyzers

The ability of the analyzer's LAN to function can be easily tested by connecting two analyzers together using a "crossover cable" (a short length of cable with an RJ-45 connector on each end).

Some network hubs have the capability to make a crossover connection using two normal, or

---

1. The letters x represent the IP address of the analyzer.

straight-through, cables. If this capability is not available and a crossover cable is not available, a crossover cable can be made by following the directions in [“Constructing a Crossover Cable”](#) on page 4-22.

Set the IP addresses on two analyzers. The addresses can be set to anything, but they must be different. Make sure the subnet mask and gateway addresses are set to 0.0.0.0 and that the LAN is active on both analyzers. Connect the two analyzers together using either a crossover cable or a crossover hub.

Now follow the steps in [“How to Ping from the Analyzer to the Local Area Network \(LAN\)”](#) on page 4-20 to have the first analyzer ping the second analyzer. When done, repeat the procedure having the second analyzer ping the first. If both procedures function properly, the LAN circuitry on both analyzers is verified.

If neither function properly:

- One or both IP addresses could be wrong.
- One or both LAN states could be set to off.
- The crossover cable could be miswired.
- One or both analyzers could be defective.

If possible, eliminate the possibility of a defective analyzer by substitution of a known working unit. Once the analyzer has been proven to be working properly, concentration can be placed on the network itself to determine the cause of the failure.

### Constructing a Crossover Cable

A crossover cable can be made from a standard LAN cable by connecting pin 1 from each connector to pin 3 of the other connector, and pin 2 from each connector to pin 6 of the other connector.

1. Strip away a few inches of the outside jacket insulation from the middle of a standard LAN cable that has an RJ-45 connector on each end.

---

**NOTE** Pins 1, 2, 3, and 6 of the connectors must be located to determine which wires to cut in the following steps. Most, but not all, LAN cables use the color coding listed in [Table 4-3](#). If your cable does not use this color scheme, you will have to determine the locations of the appropriate wires before proceeding with this procedure.

---

**Table 4-3 LAN Pin Definitions and Wire Color Codes**

Pin Number	Color	Pin Number	Color
1 (transmit +)	White/orange	5	White/blue
2 (transmit -)	Orange	6 (receive -)	Green
3 (receive +)	White/green	7	White/brown
4	Blue	8	Brown

2. Cut the wires going to pins 1, 2, 3, and 6. Strip away a small amount of insulation from each of the eight cut ends.
  - a. Connect the wire from pin 1 on one end of the cable to the wire from pin 3 on the other end of the cable.
  - b. Connect the wire from pin 3 on one end of the cable to the wire from pin 1 on the other end of the cable.
  - c. Connect the wire from pin 2 on one end of the cable to the wire from pin 6 on the other end of the cable.
  - d. Connect the wire from pin 6 on one end of the cable to the wire from pin 2 on the other end of the cable.
3. Insulate all exposed wires so that they cannot short together.
4. Label this as a crossover cable so that it cannot be confused with a standard cable.

**Figure 4-5 Construction of a Crossover Cable**

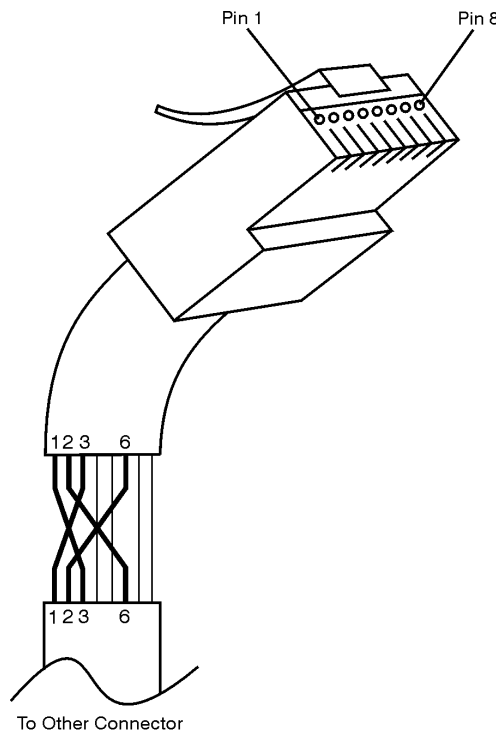

sde23c

---

## Measurement System Troubleshooting

This section provides troubleshooting procedures for the measurement portion of the PNA series network analyzer. In this section, the analyzer is used as a tool to help isolate the suspected faulty functional group. Once the faulty functional group is determined, troubleshooting steps are provided to help you isolate the faulty assembly or part.

This section is divided into two major sections for troubleshooting. The first section *mainly* covers the standard S-parameter measurement troubleshooting (pages 4-26 thru page 4-42). However, some parts are applicable for the frequency offset section. The second section is for troubleshooting the frequency offset section, option 080 (refer to pages 4-44 thru pages 4-48). The “Checking the Frequency Offset Group (Option 080)” on page 4-44 section will also reference portions of the S-parameter troubleshooting section in its troubleshooting process as well as the troubleshooting of the E836xB, option 081 (external reference switch option).

### Before you begin—consider: Where do you see a problem?

If you are seeing a problem at **Preset**, perform the standard S-parameter test set troubleshooting procedure, starting with: “Verifying the A, B, R1, and R2 Traces (Standard S-Parameter Mode)” on page 4-26.

You should also consider the problem indications that are observed and whether the observed condition is a soft failure or a hard failure.

#### Soft Failure

With a *soft* failure, the network analyzer's performance has degraded to an unacceptable level, yet it continues to operate and displays no error messages. For this type of failure, performance tests must be conducted to isolate the problem. Begin with viewing the error terms as described in “Error Terms” in Chapter 8. This will help to isolate most problems. If additional tests are required, refer to “Performance Tests (Agilent N7840A Software Package)” on page 3-30.

#### Hard Failure

With a *hard* failure, the PNA does not perform well and displays one or more error messages. To diagnose and repair a hard failure:

- Check “Help About” to verify that the model number and options listed match the actual analyzer model and options.
- Check “EEPROM Headers” to verify that the data there is correct.
- Check error messages. Refer to “Error Messages” and follow the suggestions outlined there for each applicable error message.

#### Help About

Go to the Help About screen by selecting **Help, About Network Analyzer** in the network analyzer application. Verify that the information displayed in this screen is correct for your analyzer. If any of the information is incorrect, contact Agilent Technologies. Refer to “Contacting Agilent” on page 2-12.



### EEPROM Headers

The network analyzer application uses the firmware revision information stored in the pc board header EEPROM. If the information stored in any EEPROM is incorrect, the network analyzer may not operate properly.

The following table lists the pc boards in your network analyzer that contain EEPROM headers. The pc boards are listed by name and part number and the correct firmware revision code is given for each.

PC Board Name	PC Board Part Number	Memory ID	Hardware ID	Firmware Revision
A5 SPAM	E8356-60006	3	6	A
A8 and A9 fractional-N synthesizer	E8364-60099	3	8	C
A10 frequency reference	E8364-60136	3	10	B
A11 phase lock	E8364-60137	3	11	C
ALC source (P/O A12 source 20)	E8362-60001	3	12	B
A13 frequency offset receiver	E8364-60097	3	13	A
A16 test set motherboard	E8364-60138	3	16	C

To view this EEPROM header information on the network analyzer display, select **System, Service, Utilities, View EEPROM Headers** in the network analyzer application.

If the information is incorrect for any of the pc boards, contact Agilent Technologies. Refer to [“Contacting Agilent” on page 2-12](#).

### Error Messages

**PHASE LOCK LOST:** The level of the signal from at least one of the reference receivers, and sensed by the A11 phase lock board, is too low to be accurately captured. This could be due to a problem in the source group, signal separation group, or receiver group (refer to [“Checking the Source Group” on page 4-30](#), [“Checking the Signal Separation Group” on page 4-38](#), and [“Checking the Receiver Group” on page 4-42](#)).

**SOURCE UNLEVELED:** The source ALC circuits on the A12 source or the A16 test set motherboard—E8363C and E8364C only—is running open-loop. For the E8362C, replacing the A12 source can correct this. For the E8363C or E8364C, check the cable connections for W37 and W38 from the A23 and A24 detectors to the A16 test set motherboard, and for W39 from A16 to the A21 SOMA 50. If the problem is associated with one port and not the other, replace the detector associated with the problem port. If the problem affects both ports, replace the A16 test set motherboard.

## Verifying the A, B, R1, and R2 Traces (Standard S-Parameter Mode)

**NOTE** There is no way to view the frequency offset receiver response (Option 080). However, some standard S-parameter receiver trace information is helpful in troubleshooting the frequency offset section of the PNA. It is therefore recommended that you run this test even if you *only* suspect the frequency offset section of malfunctioning.

The first step is to verify that the A, B, R1, and R2 traces are present and that they are approximately level:

- Connect an Open or Short standard from a mechanical calibration kit to each test port (use adapters if necessary).
- On the **System** menu, point to **Service, Utilities**, and then click **Receiver Display**.
- Traces A, B, R1, and R2 are displayed in four separate data windows as shown in [Figure 4-6](#). Identifying discrepancies of the traces in these windows can help you to isolate the faulty assembly.

**Figure 4-6 Typical Four Channel Display**

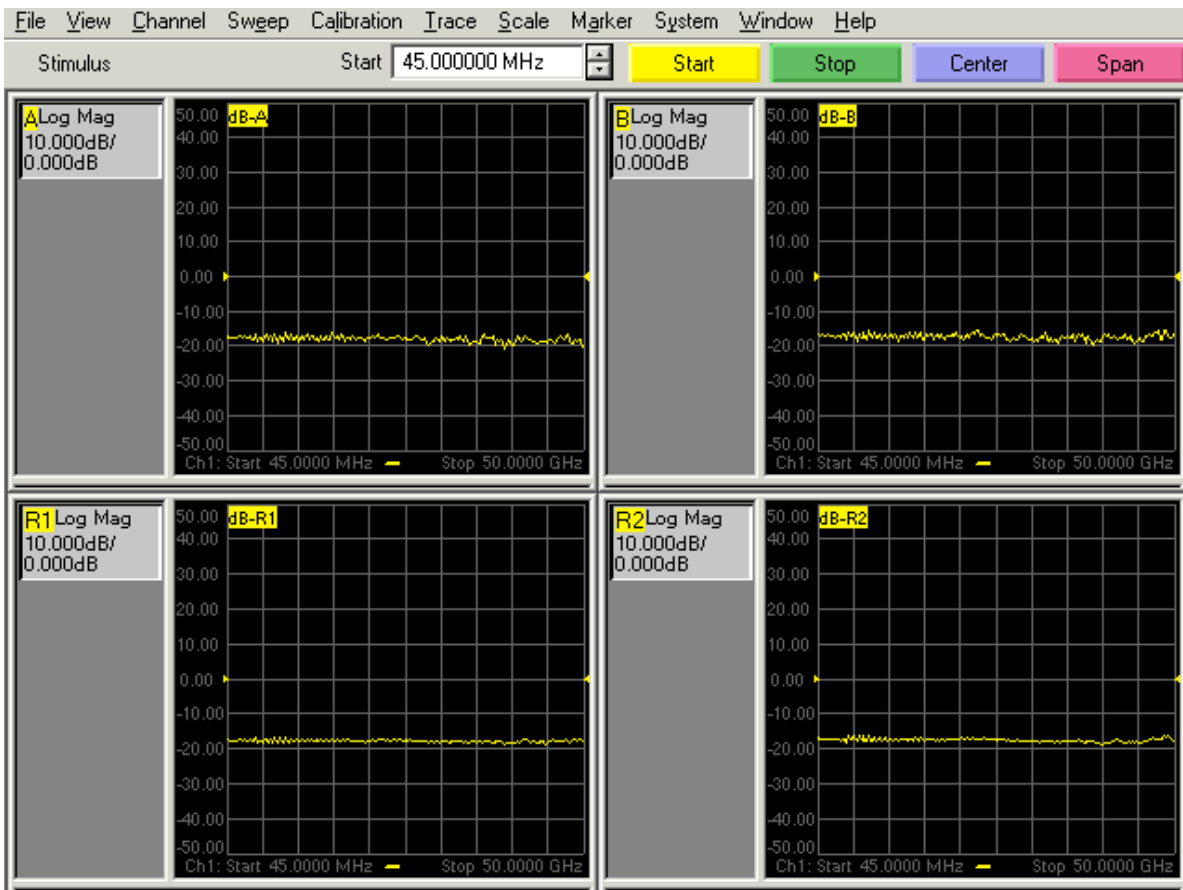

- If all traces are present and are similar to the traces in [Figure 4-6](#), then there are no major problems with the analyzer's measurement system. There may, however, be a minor failure in the analyzer.  
To test further:
  - Go to [Chapter 3](#), “[Tests and Adjustments](#),” and perform all the tests in that section.
  - If a problem still exists, contact Agilent. Refer to “[Contacting Agilent](#)” on [page 2-12](#).
- If any of the traces are not present, are noisy or distorted, or are at an incorrect level, then there is a problem with the analyzer's measurement system. Proceed to “[Where to Begin Troubleshooting](#)”.

## Where to Begin Troubleshooting

For the purposes of troubleshooting, the analyzer block diagram is divided into the following functional groups:

- **the source group**
  - A8 fractional-N synthesizer
  - A10 frequency reference
  - A11 phase lock
  - A12 source 20
  - A16 test set motherboard
  - A17 LOMA 10
  - A18 MA 20
  - A19 splitter
  - A20 LODA
  - A21 SOMA 50 (E8363C and E8364C only)
- **the signal separation group**
  - A22 switch splitter
  - A23 and A24 detectors (E8363C and E8364C only)
  - 30-dB fixed attenuators (E8362C only)
  - A25 and A26 test port couplers
  - A36 and A37 60-dB step attenuators (Option UNL only)
  - A38 and A39 bias tees (Option UNL only)
  - Port 1, Port 2, A, B, R1, and R2 ports
- **the receiver group**
  - A27, A28, A29, and A30 first converters
  - A31 receiver A
  - A32 receiver R1
  - A33 receiver R2
  - A34 receiver B
  - A35 receiver motherboard
  - A6 SPAM
- **the frequency offset group (Option 080 only)**
  - A9 fractional-N synthesizer (Option 080 only)

- A10 frequency reference
- A12 source 20
- A13 frequency offset receiver (Option 080 only)
- A45 and A46 switches (Option 081 only)

Use the list on the following pages to help you determine in which analyzer functional group to begin troubleshooting.

This is by no means an exhaustive list of possible symptoms nor possible failures. It is recommended that you view the system block diagram, located at the end of this chapter, as you review the entries in this list and while performing any of the troubleshooting procedures listed.

Good judgement and established logical troubleshooting techniques must be used to complement the procedures contained in this section.

Refer to [Table 4-4 on page 4-36](#) for a list of the frequencies associated with each of the network analyzer's 26 bands.

### All Traces

- ***If all traces are missing in all bands***, the problem is most likely in the source group. However, a missing or disabled DSP driver may exhibit the same or similar symptoms. To verify that this DSP driver is present and enabled:
  1. Click My Computer, **Properties**, **Hardware** tab, **Device Manager**. Expand **Agilent PNA DSP device**. The following entry should be listed: **Agilent Technologies DSP Driver #2** and should be enabled.
  2. If the icon to the left of the name is a yellow box containing an exclamation mark (!), use Windows Explorer to verify the presence of the following file: C:\WINNT\system32\drivers\spampnp.sys.
  3. If you have verified that the DSP driver is present and enabled, but all traces are still missing in all bands, go to ["Checking the Source Group" on page 4-30](#).
- ***If the trace faults are band-related***, the problem is in the source group. Using [Table 4-4 on page 4-36](#), note the frequency bands in which problems are seen. Go to ["Checking the Source Group" on page 4-30](#) and check the A8 fractional-N synthesizer board outputs and the A10 frequency reference board outputs.

## R1 and A Traces

***If both traces are affected, the problem is in the R1 phase lock loop.***

- ***If both traces are missing in all bands***, the problem is in the A16 test set motherboard, the A28 R1 first converter, the A32 R1 receiver, or the A22 switch splitter. To determine which is at fault:
  1. Bypass the A22 switch splitter using a flexible RF cable connected between the input cable W2 and the R1 output cable W3.
  2. If the R1 trace is now present, replace the A22 switch splitter. If the R1 trace is still missing, reconnect the cables to the A22 switch splitter.
  3. Swap the A32 R1 receiver with the A33 R2 receiver. (Each of the four receivers is identical.)
  4. If the missing trace is now R2 (still associated with the same A32 R1 receiver), replace the A32 R1 receiver. If the R1 trace is still missing, replace the A16 test set motherboard.

## R2 and B Traces

***If both traces are affected, the problem is in the R2 phase lock loop.***

- ***If both traces are missing in all bands***, the problem is in the A16 test set motherboard, the A29 R2 first converter, the A33 R2 receiver, or the A22 switch splitter. To determine which is at fault:
  1. Bypass the A22 switch splitter using a flexible RF cable connected between the input cable W2 and the R2 output cable W4.
  2. If the R2 trace is now present, replace the A22 switch splitter. If the R2 trace is still missing, reconnect the cables to the A22 switch splitter.
  3. Swap the A33 R2 receiver with the A32 R1 receiver. (Each of the four receivers is identical.)
  4. If the missing trace is now R1 (still associated with the same A33 R2 receiver), replace the A33 channel R2 receiver. If the R2 trace is still missing, replace the A16 test set motherboard.

## R1 Trace Only

A problem that affects only the R1 trace is isolated to the A28 R1 first converter, the A32 R1 receiver, or the A6 SPAM board. Go to [“Checking the Receiver Group” on page 4-42](#).

## R2 Trace Only

A problem that affects only the R2 trace is isolated to the A29 R2 first converter, the A33 R2 receiver, or the A6 SPAM board. Go to [“Checking the Receiver Group” on page 4-42](#).

## A Trace Only

If the trace is missing in all bands, go to [“Checking the Signal Separation Group” on page 4-38](#).

## B Trace Only

If the trace is missing in all bands, go to [“Checking the Signal Separation Group” on page 4-38](#).

## Checking the Source Group

### Source Group Tests

**NOTE** A defective A22 switch splitter can exhibit the same symptom as a faulty source. Therefore, if it is determined that the source is functioning properly, you are directed to [“Checking the Signal Separation Group”](#) on page 4-38.

### Equipment Used for These Tests

Equipment Type	Models Used With	Model or Part Number	Alternate Model or Part Number
Spectrum analyzer	All	8565E	None
Power meter	All	E4418B/19B	E4418A/19A
Power sensor, 3.5 mm	E8362C	8485A	None
RF cable, 3.5 mm (f) to 3.5 mm (f)	E8362C	85131C	Any
Power sensor, 2.4 mm	E8363C, E8364C	8487A	None
RF cable, 2.4 mm (f) to 2.4 mm (f)	E8363C, E8364C	85133C	Any

### Getting Ready to Test

Before checking the assemblies, you must open the analyzer.

**CAUTION** Use an antistatic work surface and wrist strap to reduce the chance of electrostatic discharge for all of the procedures in this chapter.

1. Turn off the analyzer power.
2. Unplug the power to the analyzer and disconnect all rear panel connections.
3. Remove the covers from the analyzer. Refer to [“Removing the Covers”](#) on page 7-6.
4. With the covers off, plug in the analyzer and turn on the power.

### Single vs. Broadband Failure

There are two main types of failures that are related to the source group. The failures are classified as:

- broadband
- single band

Single band failures are indicated by all four channel traces having partial dropouts across the frequency range or intermittent phase lock problems. Troubleshooting information is provided under “If the traces faults are band-related,” under [“All Traces”](#) on page 4-28.

Broadband failures are indicated by all four channel traces being in the noise floor. Most often this is due to problems in the phase lock signal path and will be characterized by a “PHASE LOCK LOST” error message on the display.

A phase lock problem is due to either:

- faulty RF signal generation (caused by the A12 source 20, A21 SOMA 50, A23 and A24 SOMA 70)
- faulty LO signal generation (caused by the A8, A10, A11, A17 or A18 board)

### RF Signal Troubleshooting

To isolate a broadband RF signal generation failure, check the test port output power:

1. Connect a power meter and power sensor to Port 1 of the analyzer.
2. On the analyzer, press **Preset**, set the **Center Frequency** to **2 GHz**, and the **Frequency Span** to **0 Hz**. Note the power reading displayed on the power meter. The output power, as indicated on the power meter, should be approximately  $-12 \text{ dBm} \pm 5 \text{ dB}$  for an analyzer with no hardware options or  $-17 \text{ dBm} \pm 5 \text{ dB}$  for an analyzer with options.

---

**NOTE** In the unlocked state, the analyzer will “search” for the reference signal.

---

3. Connect the power sensor to Port 2 and set trace to measure  $S_{22}$ . Note the power reading displayed on the power meter. The power meter reading should be the same as was measured at Port 1.
- If the power level is low at both test ports the problem is either the A12 source 20 or the A21 SOMA 50. Continue with [“Checking the A12 Output, All Bands”](#).

### Checking the A12 Output, All Bands

1. Disconnect W1 from A12.
2. Connect a cable to A12 and measure the output power. A power level of a  $-17 \text{ dBm} \pm 5 \text{ dB}$  indicates the A12 assembly is functioning normally.
3. If the output power of A12 is at or below the minimum power level, replace the A12 source 20 assembly.
4. If the output power is normal, reconnect cable W1 to A12.

### Checking the A21 Output (E8363C and E8364C Only)

1. Disconnect W2 from A21.
2. Connect a cable to A21 and measure the output power. A power level of a  $-7 \text{ dBm} \pm 5 \text{ dB}$  indicates the A21 assembly is functioning normally.
3. If the output power of A21 is at or below the minimum power level, replace the A21 SOMA 50 assembly.
4. If the output power is normal, reconnect cable W2 to A21.

### Checking the A10 5 MHz Reference Output, All Bands

1. Refer to the block diagram at the end of this chapter and to [“Top Cables—All, All Options Except 080” on page 6-16](#). Locate flexible cable W31, at the A10 frequency reference board.
2. Disconnect W31 from A10J10.
3. Connect the spectrum analyzer to A10J10.
4. The spectrum analyzer should measure a signal at 5 MHz.
5. If no 5 MHz signal is present, replace the A10 frequency reference board. Refer to [“Removing and Replacing the A6, A8, A9, and A10 Boards” on page 7-18](#).



6. If the 5 MHz signal is present, reconnect cable W31, and then continue with “[Checking the A10 Phase Lock Reference Output, All Bands](#)” on page 4-33.

#### Checking the A10 Phase Lock Reference Output, All Bands

1. Refer to the block diagram at the end of this chapter and “[Top Cables—All, All Options Except 080](#)” on page 6-16. Locate flexible cable W32 at the A10 frequency reference board.
2. Disconnect W32 from A10J5.
3. Connect the spectrum analyzer to A10J5.
4. Verify the presence of the 8.333 MHz phase lock reference output signal.
5. If the signal is not present, replace the A10 frequency reference board. Refer to “[Removing and Replacing the A6, A8, A9, and A10 Boards](#)” on page 7-18.
6. If the signal is present, reconnect cable W32, and then continue with “[Checking the 2nd LO at the A10 Frequency Reference, All Bands](#)” on page 4-33.

#### Checking the 2nd LO at the A10 Frequency Reference, All Bands

Perform this procedure if a problem is in one of the receiver channels and appears to be a band related problem.

1. Refer to the block diagram at the end of this chapter and to “[Top Cables—All, All Options Except 080](#)” on page 6-16. Locate the flexible cable W29 at the A10 frequency reference board.
2. Disconnect the flexible cable W29 at A10J4.
3. Connect the spectrum analyzer to A10J4.
4. Verify the presence of the 33.1667 MHz signal at A10J4.
5. If the signal is not present, replace the A10 frequency reference board. Refer to “[Removing and Replacing the A6, A8, A9, and A10 Boards](#)” on page 7-18.
6. If the signal is present, reconnect cable W29, and then go to “[Checking the A31 through A34 Receiver Outputs](#)” on page 4-43.

#### Checking the A8 Fractional-N Synthesizer Band 0 and1 Output

1. Refer to the block diagram at the end of this chapter and to “[Top Cables—All, All Options Except 080](#)” on page 6-16. Locate the flexible cable W20, at the A8 fractional-N synthesizer board.
2. Disconnect W20 from A8J101.
3. Connect the spectrum analyzer to A8J101.
4. Set the network analyzer for a 500 MHz CW frequency and observe the spectrum analyzer measurement.
  - The spectrum analyzer should measure a signal at 508.33 MHz.
5. If the 508.33 MHz signal is not present and the 5 MHz reference signal is present from “[Checking the A10 5 MHz Reference Output, All Bands](#),” replace the A8 fractional-N synthesizer board. Refer to “[Removing and Replacing the A6, A8, A9, and A10 Boards](#)” on page 7-18.
6. If the signal is present, reconnect cable W20, and then continue with “[Checking the A8 Fractional-N Synthesizer Band 2 Output](#)” on page 4-34.

### Checking the A8 Fractional-N Synthesizer Band 2 Output

Perform this procedure if you observe a problem in band 2 in all receivers.

1. Refer to the block diagram at the back of this chapter and to [“Top Cables—All, All Options Except 080” on page 6-16](#). Locate semirigid cable W19, at the A8 fractional-N synthesizer board.

---

**CAUTION** Be careful not to damage the center pins of the semirigid cable. Some flexing of the cables is necessary to measure the output.

---

2. Using a 5/16-inch torque wrench, disconnect W19 at A8J106.
3. Connect the spectrum analyzer to A8J106.
4. Set the network analyzer to a CW frequency of 1 GHz.
  - The spectrum analyzer should measure a signal at 1.008 GHz.
5. If this signal is not present, replace the A8 fractional-N synthesizer board. Refer to [“Removing and Replacing the A6, A8, A9, and A10 Boards” on page 7-18](#).
6. If the signal is present, leave the spectrum analyzer connected to A8J106 and continue with [“Checking the A8 Fractional-N Synthesizer Band 3 through 25 Output” on page 4-34](#).

### Checking the A8 Fractional-N Synthesizer Band 3 through 25 Output

Perform this procedure if you observe a problem in bands 3 through 25 in all receivers.

1. Set the network analyzer to a CW frequency of 2 GHz.
  - The spectrum analyzer should measure a signal at 2.008 GHz.
2. If the signal is not present, replace the A8 fractional-N synthesizer board. Refer to [“Removing and Replacing the A6, A8, A9, and A10 Boards” on page 7-18](#).
3. If the signal is present, reconnect cable W19, and then continue with [“Checking the A17 LOMA 10, All Bands \(With All A8 Signals Present\)” on page 4-34](#).

### Checking the A17 LOMA 10, All Bands (With All A8 Signals Present)

Perform this procedure if you observe a problem in any band and all signals from the A8 fractional-N synthesizer are present.

1. Refer to the block diagram at the back of this chapter and to [“Bottom Semi-Rigid Cables, No Options” on page 6-24](#). Locate semirigid cable W18, at the A17 LOMA 10.

---

**CAUTION** Be careful not to damage the center pins of the semirigid cable. Some flexing of the cables is necessary to measure the output.

---

2. Using a 5/16-inch torque wrench, disconnect W18 at the A17 LOMA 10.
3. Connect the spectrum analyzer to the open A17 connector.
4. For each frequency band in which problems were seen: Set the network analyzer to each of the frequencies indicated in the [“Network Analyzer Source Frequency Setting \(GHz\)”](#) column in [Table 7 on page 4-36](#).
5. Set the spectrum analyzer to measure each of the corresponding frequencies in the column labeled: [“Expected A17 Output Frequency \(GHz\)”](#) in [Table 7 on page 4-36](#).

6. If the signals are  $< -30$  dBm or not present, replace the A17 LOMA 10. Refer to [“Removing and Replacing the A17 LOMA 10” on page 7-34](#).
7. If the signals are present, reconnect cable W18, and then continue with [“Checking the A18 MA 20 Output” on page 4-37](#).

**Table 4-4 LO Path Frequencies**

Model	Band	Network Analyzer Frequency Band of Problem (GHz)	Network Analyzer Source Frequency Setting (GHz)	Expected A17 Output Frequency (GHz)	Expected A18 Output Frequency (GHz)
E8362C, E8363C, E8364C	0	0.010 to 0.045	0.025	0.026	0.026
	1	0.045 to 0.748	0.500	0.508	0.508
	2	0.748 to 1.500	1.000	1.008	1.008
	3	1.50 to 3.00	2.200	2.208	2.208
	4	3.00 to 3.80	3.400	3.408	3.408
	5	3.80 to 4.50	4.200	4.208	4.208
	6	4.50 to 4.80	4.600	4.608	4.608
	7	4.80 to 6.00	5.400	5.408	5.408
	8	6.00 to 6.40	6.200	6.208	6.208
	9	6.40 to 7.60	7.000	7.008	7.008
	10	7.60 to 10.00	8.800	8.808	8.808
	11	10.00 to 12.00	11.000	5.504	11.008
	12	12.00 to 12.80	12.400	6.204	12.408
	13	12.80 to 15.20	14.000	7.004	14.008
	14	15.20 to 16.00	15.600	7.804	15.608
E8363C, E8364C	15	16.00 to 20.00	18.000	9.004	18.008
	16	20.00 to 22.80	21.400	7.136	7.136
	17	22.80 to 25.60	24.200	8.069	8.069
	18	25.60 to 30.00	27.800	9.269	9.269
	19	30.00 to 32.00	31.000	5.168	10.336
	20	32.00 to 36.00	34.000	5.668	11.336
	21	36.00 to 38.40	37.200	6.201	12.403
E8364C	22	38.40 to 40.00	39.200	6.535	13.069
	23	40.00 to 45.60	42.800	7.135	14.269
	24	45.60 to 48.00	46.800	7.801	15.602
	25	48.00 to 50.00	49.000	8.168	16.336

### Checking the A18 MA 20 Output

Perform this procedure if you observe a problem in any band and all signals from the A8 fractional-N synthesizer are present.

1. Refer to the block diagram at the back of this chapter and to [“Bottom Semi-Rigid Cables, No Options” on page 6-24](#). Locate semirigid cable W17, at the A18 MA 20.

---

**CAUTION** Be careful not to damage the center pins of the semirigid cable. Some flexing of the cables is necessary to measure the output.

---

2. Using a 5/16-inch torque wrench, disconnect W17 at the A18 MA20.
3. Connect the spectrum analyzer to the open A18 connector.
4. For each frequency band in which problems were seen: Set the network analyzer to each of the frequencies indicated in the [“Network Analyzer Source Frequency Setting \(GHz\)”](#) column in [Table 7 on page 4-36](#).
5. Set the spectrum analyzer to measure each of the corresponding frequencies in the column labeled: [“Expected A18 Output Frequency \(GHz\)”](#) in [Table 7 on page 4-36](#).
6. If the signals are <-30 dBm or not present, replace the A18 MA 20. Refer to [“Removing and Replacing the A18 MA 20” on page 7-36](#).
7. If the signals are present, reconnect cable W17, and then continue with [“Checking the A20 LODA Output” on page 4-37](#).

### Checking the A20 LODA Output

Perform this test if you observe a problem in all bands or a single channel.

1. Refer to the block diagram at the back of this chapter and to [“Bottom Semi-Rigid Cables, No Options” on page 6-24](#). Locate cables W11, W12, W13, and W14, at the A20 LODA.
2. Using a 5/16-inch torque wrench, disconnect the cable associated with the faulty channel (W11, W12, W13, or W14) and connect the spectrum analyzer to the A20 LODA connector.
3. Set the network analyzer to any one of the frequencies listed in [Table 7 on page 4-36](#).
4. Set the spectrum analyzer to measure the corresponding A18 output frequency listed in [Table 7](#).
5. If the signal is not present, replace the A20 LODA. Refer to [“Removing and Replacing the A20 LODA” on page 7-40](#).
6. If the signal is present, reconnect the cable, and then go to [“Checking the Receiver Group” on page 4-42](#).

## Checking the Signal Separation Group

Before checking the signal separation group, perform the following procedures:

- [“Getting Ready to Test” on page 4-31](#)

## Checking the Output Power of the A and B Signals

Using a power meter, you can measure the outputs of the A and B signals from the front panel. The measurement results will help you isolate a faulty assembly. The outputs of the R1 and R2 channels cannot be measured because it would necessitate breaking the phase lock loop, causing all of the signals to be lost.

### Equipment Used for These Tests

Equipment Type	Models Used With	Model or Part Number	Alternate Model or Part Number
Power meter		E4418B/E441B	E4418A/E4419A
Power sensor	E8362C	E8485A	None
Adapter, 3.5 mm (f) to 3.5 mm (f)	E8362C	83059B	85052-60012
Power sensor, 2.4 mm	E8363C, E8364C	8487A	None
Adapter, 2.4 mm (f) to 2.4 mm (f)	E8363C, E8364C	11900B	85056-60007

### Equipment Setup

1. Before starting these checks, zero and calibrate the power meter. (See the power meter user’s guide for instructions on setting the calibration factor.)
2. If the **Receiver Display** (Figure 4-6) is not on the analyzer screen, perform the following: On the **System** menu, point to **Service, Utilities**, and then click **Receiver Display**.
3. Set the sweep speed for a 10 second sweep: On the **Sweep** menu, click **Sweep Time** and set the time to 10.000 seconds in the **Sweep Time** box.

### Checking Port 1 Power (A Signal)

The object of this check is to verify the power of the A signal across the entire frequency range. Perform this test if there is an observed problem only with the channel A trace. The ten second sweep is slow enough to allow you to observe the output power on the power meter as the sweep occurs.

1. Connect the power sensor to Port 1.
2. Observe the power reading on the power meter as the sweep occurs on the analyzer.
3. The measured output power on the power meter should be within -12 dBm  $\pm$ 4 dB for E836xB with no options or -17 dBm  $\pm$ 4 dB for E836xB with options, over the entire frequency range.
  - If the measured power is correct, go to [“Checking the Receiver Group” on page 4-42](#).
  - If the measured power is not correct, go to [“Checking the Signal through the Signal Separation Path” on page 4-39](#).

### Checking Port 2 Power (B Signal)

The object of this check is to verify the power of the B signal across the entire frequency range. Perform this test if there is an observed problem only with the channel B trace. The ten second sweep is slow enough to allow you to observe the output power on the power meter as the sweep occurs.

1. Connect the power sensor to Port 2.
2. Observe the power reading on the power meter as the sweep occurs on the analyzer.
3. The measured output power on the power meter should be within -12 dBm  $\pm$ 4 dB for E836xB with no options or -17 dBm  $\pm$ 4 dB for E836xB with options, over the entire frequency range.

### Checking the Signal through the Signal Separation Path

For all of the following checks, refer to the block diagrams at the end of this chapter and to:

- “Bottom Assemblies, No Options” on page 6-22 and
- “Bottom Assemblies, Option UNL” on page 6-26 thru “Bottom Semi-Rigid Cables, Options UNL/014/016/080/081” on page 6-60 (as required)

Port 1 trace loss in the signal separation group is due to one or more of the following assemblies being defective:

- A22 switch splitter
- A25 test port 1 coupler
- A36 60-dB step attenuator (Option UNL)
- A38 bias tee (Option UNL)

Port 2 trace loss in the signal separation group is due to one or more of the following assemblies being defective:

- A22 switch splitter
- A26 test port 2 coupler
- A37 60-dB step attenuator (Option UNL)
- A39 bias tee (Option UNL)

### Equipment Used for These Tests

Equipment Type	Models Used With	Model or Part Number	Alternate Model or Part Number
Spectrum analyzer	All	8565E	856xE <sup>1</sup>

1. Must be capable of measuring a signal at 1 GHz.

To determine which assembly is defective, check the signal at each available measurement point in the signal path from the A22 switch splitter to the test port coupler.

For Port 1 measurements, set the network analyzer for an  $S_{11}$  measurement with a CW frequency of 1GHz.

For Port 2 measurements, set the network analyzer for an  $S_{22}$  measurement with a CW frequency of 1 GHz.

Perform the following checks in the order presented.

### Checking the A22 Switch Splitter and A25 and A26 Test Port Couplers

1. Locate the following semirigid cable at the A22 switch splitter:
  - Standard ..... W5 for Port 1 or W6 for Port 2
  - Option UNL ..... W51 for Port 1 or W52 for Port 2
  - Option 014 ..... W61 for Port 1 or W62 for Port 2
  - Option UNL/014 ..... W51 for Port 1 or W52 for Port 2
2. Using a 5/16-inch torque wrench, disconnect the semirigid cable at the A22 switch splitter.
3. Connect the spectrum analyzer to the connector. Set the spectrum analyzer to measure a signal at 1GHz.
4. If the 1 GHz signal is not present, replace the A22 switch splitter. Refer to [“Removing and Replacing the A22 Switch Splitter” on page 7-44](#).
5. If the 1 GHz signal is present:
  - Standard ..... replace the appropriate test port coupler. Refer to [“Removing and Replacing the A25 and A26 Test Port Couplers” on page 7-50](#).
  - Option 014 ..... replace the appropriate test port coupler. Refer to [“Removing and Replacing the A25 and A26 Test Port Couplers” on page 7-50](#).
  - Option UNL ..... reconnect the semirigid cable and go to [“Checking the A36 and A37 60-dB Step Attenuators \(Option UNL\)” on page 4-40](#).
  - Option UNL/014 ..... reconnect the semirigid cable and go to [“Checking the A36 and A37 60-dB Step Attenuators \(Option UNL\)” on page 4-40](#).

### Checking the A36 and A37 60-dB Step Attenuators (Option UNL)

1. Locate the following semirigid cable at the appropriate step attenuator:
  - Option UNL ..... W53 for Port 1 or W54 for Port 2
  - Option UNL/014 ..... W81 for Port 1 or W82 for Port 2
2. Using a 5/16-inch torque wrench, disconnect the semirigid cable at the step attenuator.
3. Connect the spectrum analyzer to the step attenuator connector. Set the spectrum analyzer to measure a signal at 1 GHz.
4. If the 1 GHz signal is not present, replace the appropriate 60-dB step attenuator. Refer to [“Removing and Replacing the A36 and A37 60-dB Source Step Attenuators \(Option UNL\)” on page 7-58](#).
5. If the 1 GHz signal is present, reconnect the semirigid cable and go to [“Checking the A38 and A39 Bias Tees \(Option UNL\)” on page 4-40](#).

### Checking the A38 and A39 Bias Tees (Option UNL)

1. Locate the following semirigid cable at the appropriate bias tee:
  - Options UNL and UNL/014 ..... W55 for Port 1 or W56 for Port 2
2. Using a 5/16-inch torque wrench, disconnect the semirigid cable at the bias tee.
3. Connect the spectrum analyzer to the step attenuator connector. Set the spectrum analyzer to measure a signal at 1 GHz.



4. If the 1 GHz signal is not present, replace the appropriate bias tee. Refer to [“Removing and Replacing the A38 and A39 Bias Tees \(Option UNL\)”](#) on page 7-60.
5. If the 1 GHz signal is present, replace the appropriate test port coupler. Refer to [“Removing and Replacing the A25 and A26 Test Port Couplers”](#) on page 7-50.

## Checking the Receiver Group

### Equipment Used for These Tests

Equipment Type	Models Used With	Model or Part Number	Alternate Model or Part Number
Spectrum analyzer	All	8565E	856xE <sup>1</sup>

1. Must be capable of measuring signals at 8.333 MHz and 41.667 MHz.

### Getting Ready to Test

Before checking the assemblies, you must open the analyzer.

---

**CAUTION** Use an antistatic work surface and wrist strap to reduce the chance of electrostatic discharge (refer to [“Protect Against Electrostatic Discharge \(ESD\)”](#) on page 4-3).

---

1. Turn off the analyzer power.
2. Unplug the power to the analyzer and disconnect all rear panel connections.
3. Remove the covers from the analyzer. Refer to [“Removing the Covers”](#) on page 7-6.
4. With the covers off, plug in the analyzer and turn on the power.
5. For Port 1 measurements, set the network analyzer for an  $S_{11}$  measurement with a CW frequency of 1 GHz.  
For Port 2 measurements, set the network analyzer for an  $S_{22}$  measurement with a CW frequency of 1 GHz.

### Checking the A27 through A30 First Converter Outputs

Perform this procedure if you observe a problem in all bands on a single channel.

1. Refer to the block diagram at the end of this chapter and to [“Bottom Flexible Cables, All Options”](#) on page 6-66. Locate the cables W21, W22, W23, and W24 at the first converters, A27, A28, A29, and A30, respectively.
2. Using a 5/16-inch torque wrench, disconnect the semirigid cable associated with the faulty channel, from the first converter.
3. Connect the spectrum analyzer to the connector to which this cable was connected.
4. The measured signal on the spectrum analyzer should be at 8.333 MHz.
5. If the signal is not present, replace the faulty first converter. Refer to [“Removing and Replacing the A27, A28, A29, and A30 First Converters \(Mixers\) and Mixer Bias Board”](#) on page 7-52.
6. If the signal is present, reconnect the cable and continue with [“Checking the A31 through A34 Receiver Outputs”](#) on page 4-43.

### Checking the A49 IF multiplexer Board Outputs

Perform this procedure if a problem appears to be in one of the receiver channels.

1. Refer to the block diagram at the end of this chapter and to [“Bottom Flexible Cables, All Options” on page 6-66](#). Locate the flexible cables W41, W42, W43, and W44.
2. Disconnect the flexible cable for the suspect channel at the A49 IF multiplexer board.
3. Connect the spectrum analyzer to the suspect open A49 IF multiplexer board connector.
4. The measured signal on the spectrum analyzer should be at 8.333 MHz.
5. If the measured signal is present, replace the cable and then continue with [“Checking the A31 through A34 Receiver Outputs” on page 4-43](#).
6. If the measured signal is not present, replace the A49 IF multiplexer board. Refer to [“Removing and Replacing the A31, A32, A33, and A34 Receiver Modules and A49 IF Multiplexer Board” on page 7-54](#).

### Checking the A31 through A34 Receiver Outputs

Perform this procedure if a problem appears to be in one of the receiver channels.

1. Refer to the block diagram at the end of this chapter and to [“Bottom Flexible Cables, All Options” on page 6-66](#). Locate the flexible cables W25, W26, W27 and W28 at each receiver IF output.
2. Disconnect the flexible cable at the suspect receiver.
3. Connect the spectrum analyzer to the suspect receiver connector.
4. The measured signal on the spectrum analyzer should be at 41.667 kHz.
  - If the measured signal is present, replace the A6 SPAM board. Refer to [“Removing and Replacing the A6, A8, A9, and A10 Boards” on page 7-18](#).
5. If the measured signal is not present, verify the receiver operation:
  - a. Replace the suspect receiver with a known good receiver. You can use a known good receiver from the same analyzer.
  - b. If the error still occurs, replace the A35 receiver motherboard. Refer to [“Removing and Replacing the A35 Receiver Motherboard” on page 7-56](#).
  - c. If the replacement receiver functions properly, replace the suspect receiver. Refer to [“Removing and Replacing the A31, A32, A33, and A34 Receiver Modules and A49 IF Multiplexer Board” on page 7-54](#).

## Checking the Frequency Offset Group (Option 080)

**CAUTION** This section troubleshoots only those circuits specifically related to the frequency offset group (option 080). Please refer to [“Where to Begin Troubleshooting”](#) on page 4-27 and refer to the appropriate standard S-parameter test—with frequency offset mode off—before proceeding with this section.

### Frequency Offset Group Tests

**NOTE** A defective A22 switch splitter can exhibit the same symptom as a faulty source. Therefore, if it is determined that the source is functioning properly, you are directed to [“Checking the Signal Separation Group”](#) on page 4-38.

### Equipment Used for These Tests

Equipment Type	Models Used With	Model or Part Number	Alternate Model or Part Number
Spectrum analyzer	All	8565E	856xE <sup>1</sup>
RF cable, 3.5 mm (f) to 3.5 mm (f)	E8362C	85131C	Any
RF cable, 2.4 mm (f) to 2.4 mm (f)	E8363C, E8364C	85133C	Any
Adapter, 3.5 mm (f) to 3.5 mm (f)	E8362C	83059B	85052-60012
Adapter, 2.4 mm (f) to 2.4 mm (f)	E8363C, E8364C	11900B	85056-60007

1. Must be capable of measuring signals from 1 MHz to 2.008 GHz.

### Getting Ready to Test

Before checking the assemblies, you must open the analyzer.

**CAUTION** Use an antistatic work surface and wrist strap to reduce the chance of electrostatic discharge for all of the procedures in this chapter.

1. Turn off the analyzer power.
2. Unplug the power to the analyzer and disconnect all rear panel connections.
3. Remove the covers from the analyzer. Refer to [“Removing the Covers”](#) on page 7-6.
4. With the covers off, plug in the analyzer and turn on the power.
5. From **Channel**, click **Frequency Offset**. In the **Frequency Offset** dialog box, click in the **Frequency Offset on/off** box to select. Click **OK**.

### Checking the A10 5 MHz Reference Output

1. Refer to the block diagram at the end of this chapter and to [“Top Cables—All, All Options Including 080”](#) on page 6-20. Locate flexible cable W115, at the A10 frequency reference board.
2. Disconnect W115 from A10J11.
3. Connect the spectrum analyzer to A10J11.

4. The spectrum analyzer should measure a signal at 5 MHz.
5. If no 5 MHz signal is present, replace the A10 frequency reference board. Refer to [“Removing and Replacing the A6, A8, A9, and A10 Boards” on page 7-18.](#)
6. If the 5 MHz signal is present, reconnect cable W115, and then continue with [“Checking the A9 Fractional-N Synthesizer Band 0 and 1 Output” on page 4-45.](#)

### Checking the A9 Fractional-N Synthesizer Band 0 and 1 Output

Perform this procedure if you observe a problem in band 1 of the frequency offset receiver.

1. Refer to the block diagram at the back of this chapter and to [“Top Cables—All, All Options Including 080” on page 6-20.](#) Locate semi-rigid cable W92, at the A9 fractional-N synthesizer board.

---

**CAUTION** Be careful not to damage the center pins of the semi-rigid cable. Some flexing of the cables is necessary to measure the output.

---

2. Disconnect W92 from A9J101.
3. Connect the spectrum analyzer to A9J101.
4. Set the network analyzer for a 500 MHz CW frequency and observe the spectrum analyzer measurement.
  - The spectrum analyzer should measure a signal at 508.33 MHz.
5. If the 508.33 MHz signal is not present and the 5 MHz reference signal is present from [“Checking the A10 5 MHz Reference Output, All Bands,”](#) replace the A9 fractional-N synthesizer board. Refer to [“Removing and Replacing the A6, A8, A9, and A10 Boards” on page 7-18.](#)
6. If the signal is present, reconnect cable W92, and then continue with [“Checking the A9 Fractional-N Synthesizer Band 2 Output” on page 4-45.](#)

### Checking the A9 Fractional-N Synthesizer Band 2 Output

Perform this procedure if you observe a problem in band 2 of the frequency offset receiver.

1. Refer to the block diagram at the back of this chapter and to [“Top Cables—All, All Options Including 080” on page 6-20.](#) Locate semi-rigid cable W91, at the A9 fractional-N synthesizer board.

---

**CAUTION** Be careful not to damage the center pins of the semi-rigid cable. Some flexing of the cables is necessary to measure the output.

---

2. Using a 5/16-inch torque wrench, disconnect W91 at A9J106.
3. Connect the spectrum analyzer to A9J106.
4. Set the network analyzer to a CW frequency of 1 GHz.
  - The spectrum analyzer should measure a signal at 1.008 GHz.

5. If this signal is not present, replace the A9 fractional-N synthesizer board. Refer to [“Removing and Replacing the A6, A8, A9, and A10 Boards” on page 7-18.](#)
6. If the signal is present, leave the spectrum analyzer connected to A9J106 and continue with [“Checking the A9 Fractional-N Synthesizer Bands 3 through 25 Output” on page 4-46.](#)

### Checking the A9 Fractional-N Synthesizer Bands 3 through 25 Output

Perform this procedure if you observe a problem in bands 3 through 25 in all receivers.

1. Set the network analyzer to a CW frequency of 2 GHz.
  - The spectrum analyzer should measure a signal at 2.008 GHz.
2. If the signal is not present, replace the A9 fractional-N synthesizer board. Refer to [“Removing and Replacing the A6, A8, A9, and A10 Boards” on page 7-18.](#)
3. If the signal is present, reconnect cable W91, and then continue with [“Checking the A12 Source 20 Output” on page 4-46.](#)

### Checking the A12 Source 20 Output

Perform this procedure if you observe a problem in any band and all signals from the A9 fractional-N synthesizer are present.

1. Refer to the block diagram at the end of this chapter and to [“Top Cables—All, All Options Including 080” on page 6-20.](#) Locate the semirigid cables W93 at the A12 source 10 output.

---

**CAUTION** Be careful not to damage the center pins of the semirigid cable. Some flexing of the cables is necessary to measure the output.

---

2. Using a 5/16-inch torque wrench, disconnect W93 at the output of the A12 source 10 board.
3. Connect the spectrum analyzer to the A12 source 10 board.
4. Set the network analyzer to a CW frequency of 1 GHz.
  - The spectrum analyzer should measure a signal at 1 GHz.
5. If the signal is not present, replace the A12 source 20 board. Refer to [“Removing and Replacing the A12 Source 20” on page 7-22.](#)
6. If the signal is present, reconnect cable W93, and then continue with [“Checking the A13 Frequency Offset Receiver Band 0 Output” on page 4-47.](#)

### Checking the A13 Frequency Offset Receiver Band 0 Output

Perform this procedure if you observe a problem in band 0 and all signals from the A12 source 20 output are present.

1. Refer to the block diagram at the end of this chapter and to [“Bottom Flexible Cables, All Options” on page 6-66](#). Locate the flexible cable W116 at the frequency offset receiver output.

---

**CAUTION** Be careful not to damage the center pins of the semirigid cable. Some flexing of the cables is necessary to measure the output.

---

2. Disconnect the flexible cable at the frequency offset receiver.
3. Connect the spectrum analyzer to the frequency offset receiver connector J6.
4. Set the network analyzer to a CW frequency of 25 MHz.
  - The spectrum analyzer should measure a signal at 1.04 MHz.
5. If the measured signal is not present, Replace the A13 receiver. Refer to [“Removing and Replacing the A13 Frequency Offset Receiver Assembly” on page 7-24](#).
6. If the signals are present, reconnect W116, and then continue with [“Checking the A45 and A46 Switches \(Option 081 Only\)” on page 4-47](#).

### Checking the A45 and A46 Switches (Option 081 Only)

---

**NOTE** Before continuing, perform the Operator’s check [“The Operator’s Check” on page 3-10](#). If the instrument passes the operator’s check then the A45 and A46 switches are ok. If you are still experiencing problems, and your instrument has passed all troubleshooting tests to this point, then contact Agilent (refer to [“Contacting Agilent” on page 2-12](#)).

---

Perform this procedure if the instrument has passed all the frequency offset receiver tests but fails the operator’s check and the problem appears to be at the A45 or A46 switches.

- Refer to the block diagram at the end of this chapter, to [“Bottom Assemblies, Options 014/080/081” on page 6-46](#), and to [“Bottom Flexible Cables, All Options” on page 6-66](#). Locate the semirigid cable W60 on the front panel. Locate the semirigid cables W96 and W99 at the A45 switch input and A45 output respectively.

---

**CAUTION** Be careful not to damage the center pins of the semirigid cable. Some flexing of the cables is necessary to measure the output.

---

1. Disconnect the W60 semirigid cable from the front panel.
2. Connect the spectrum analyzer to the **Source Out** port.
3. From the **Channel** menu, click **Test Set**. In the **Test Set** dialog box, click **External: flow through R1 loop**. Click **OK**.
4. Set the network analyzer to a CW frequency of 1 GHz.
  - The spectrum analyzer should measure a signal at 1 GHz.
5. If the measured signal is not present, replace A46 switch. Refer to [“Removing and Replacing the A45 and A46 Reference Channel Transfer Switches \(Option 081\)” on page 7-72](#).

6. If the measured signal is present, reconnect W60.
7. From the **Channel** menu, click **Test Set**. In the **Test Set** dialog box, click **Internal: bypass R1 loop**. Click **OK**.
8. Remove semirigid cable W96 from A45 switch input.
9. Connect the spectrum analyzer to the W96 cable.
10. The spectrum analyzer should measure a signal at 1 GHz.
11. If the measured signal is not present replace, A46 switch. Refer to [“Removing and Replacing the A45 and A46 Reference Channel Transfer Switches \(Option 081\)” on page 7-72](#).
12. If the measured signal is present then reconnect W96.
13. Remove W99 from the A45 switch output.
14. Connect the spectrum analyzer to the output of the A45 switch.
15. The spectrum analyzer should measure a signal at 1 GHz.
16. If the measured signal is not present replace A45 switch. Refer to [“Removing and Replacing the A45 and A46 Reference Channel Transfer Switches \(Option 081\)” on page 7-72](#).
17. If the instrument passes all the tests to this point but you still have a problem with your PNA, then refer to [“Contacting Agilent” on page 2-12](#).



**E8362C Overall Block Diagram**  
 (Includes Option UNL and 016)  
 Service Guide: E8364-90038

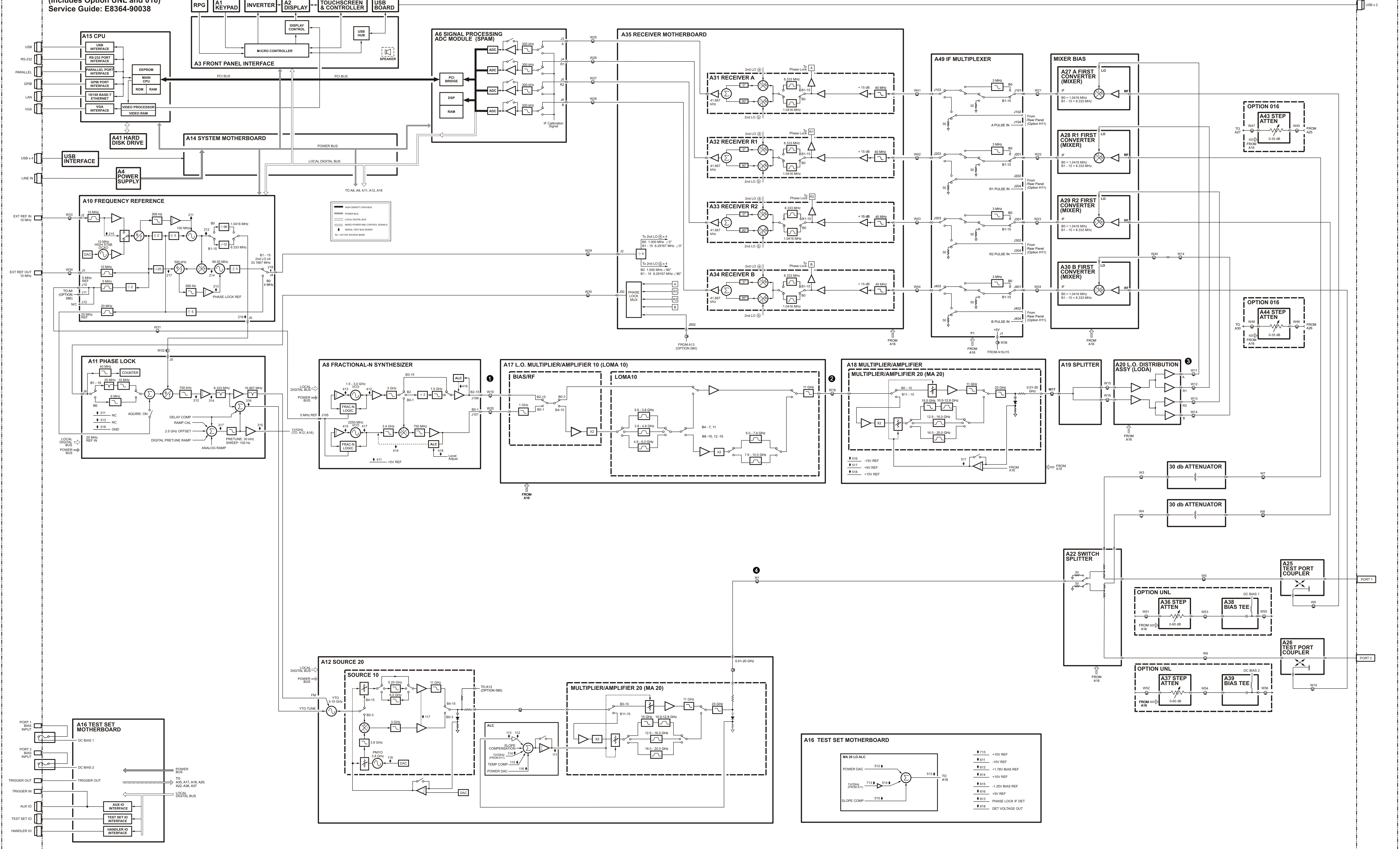



**E8362C Overall Block Diagram**  
 (Includes Option UNL, 014, 016, 080, 081, and H11)  
 Service Guide: E8364-90038

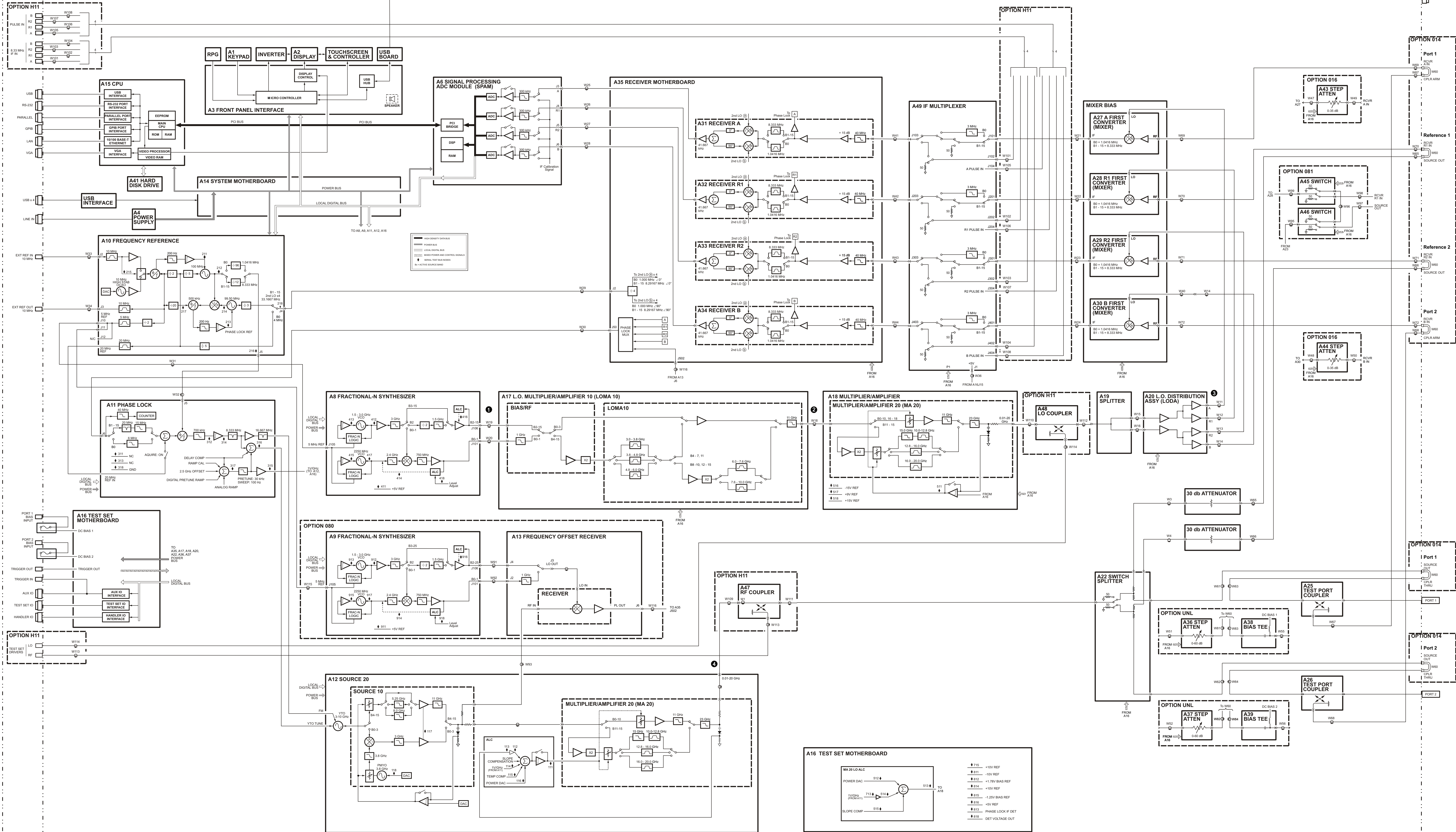



**E8363C and E8364C Overall Block Diagram**  
 (Includes Options UNL and 016)  
 Service Guide: E8364-90038

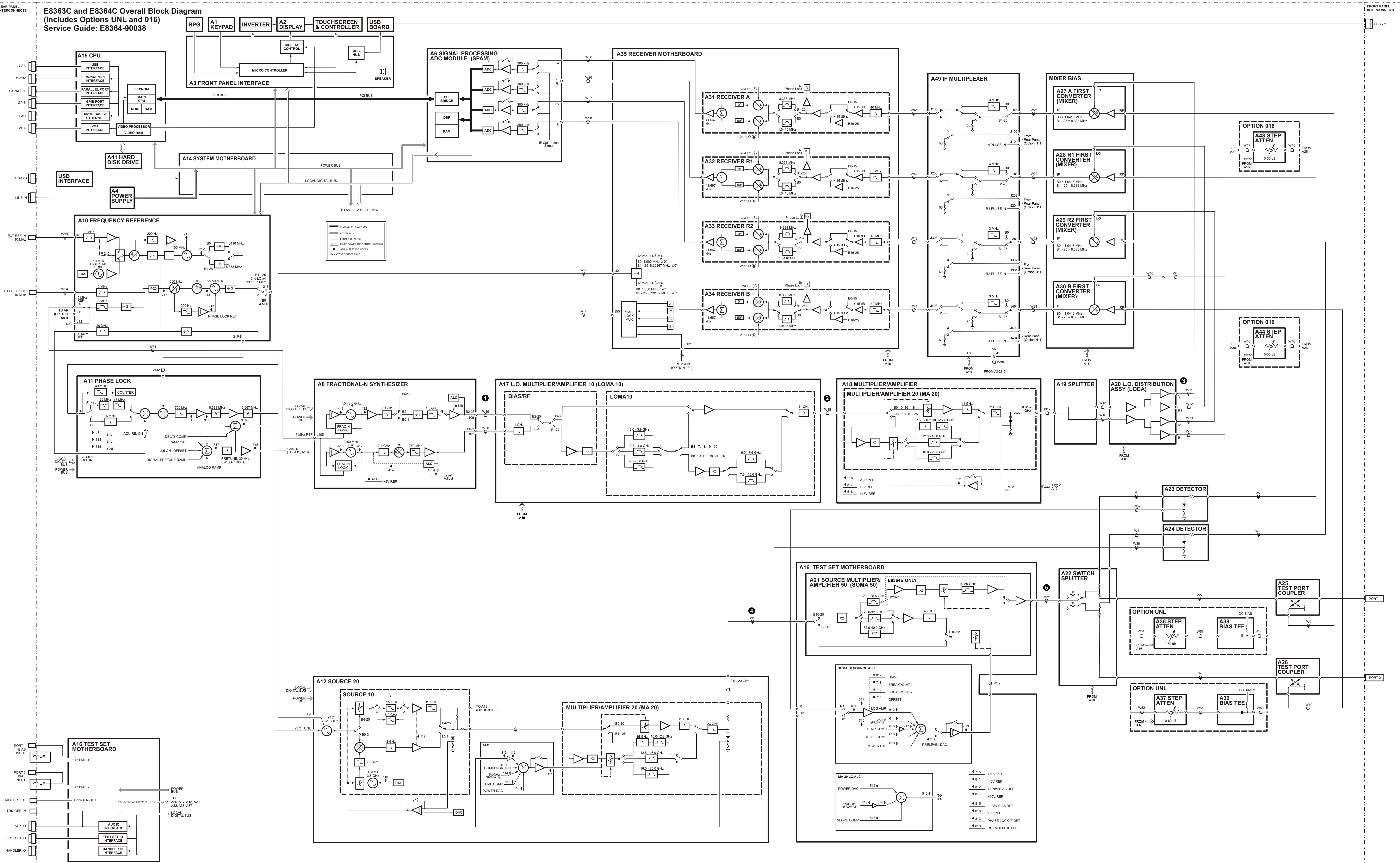



**E8363C and E8364C Overall Block Diagram**  
 (Includes Options UNL, 014, 016, 080, 081, and H11)  
 Service Guide: E8364-90038

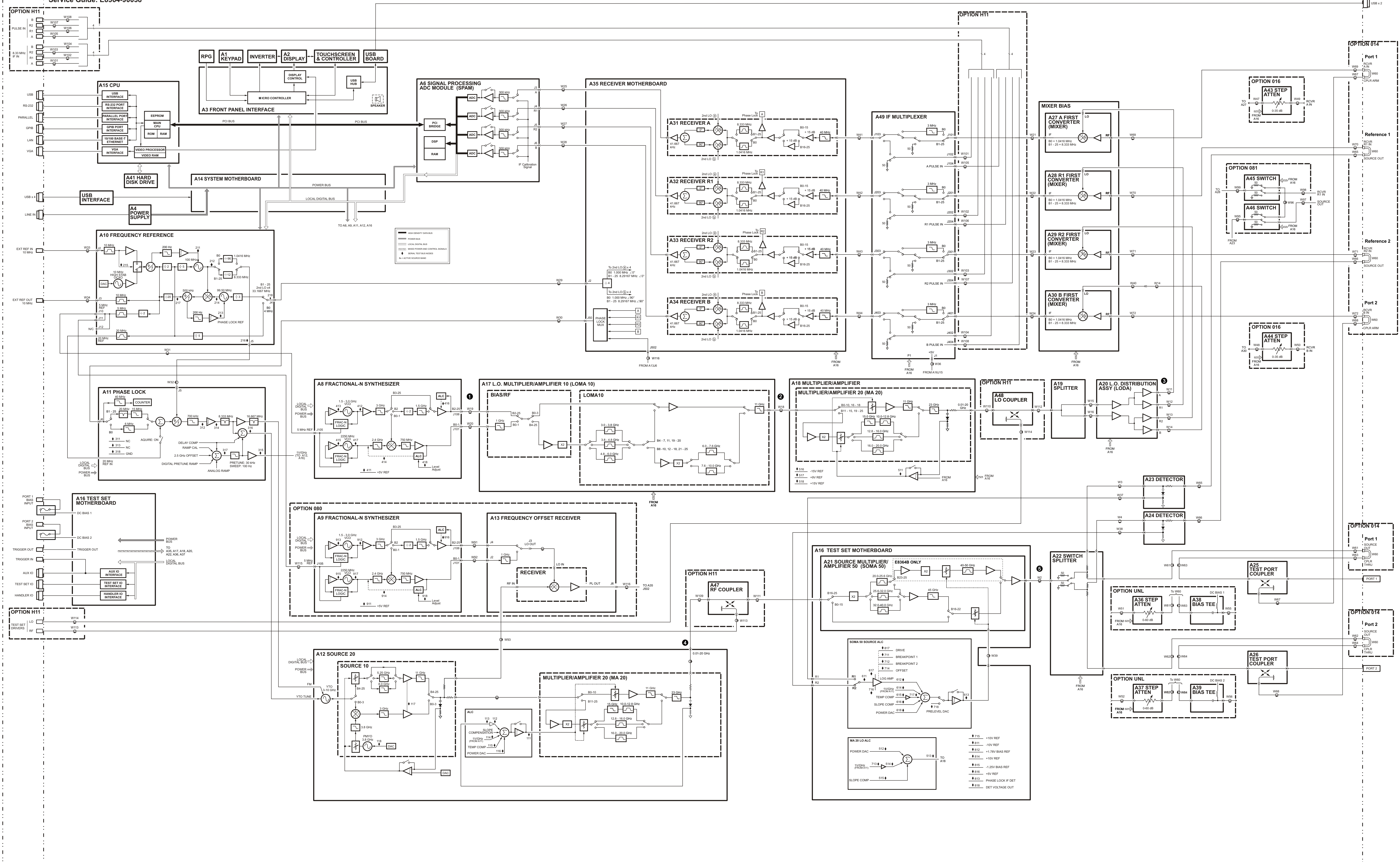





---

## **5 Theory of Operation**

---

## Information in This Chapter

This chapter provides a general description of the operating theory of the PNA series microwave network analyzers.

- Theory of operation is explained to the assembly level only.
- Component-level circuit theory is not provided.
- Simplified block diagrams are included for each functional group.
- More detailed block diagrams are located at the end of [Chapter 4, “Troubleshooting.”](#)

### Chapter Five at-a-Glance

Section Title	Summary of Content	Start Page
<a href="#">Network Analyzer System Operation</a>	A summary of the theory of operation for the analyzer. A summary of the operation of the six functional groups of the analyzer.	<a href="#">Page 5-3</a>
<a href="#">Source Group Operation</a>	Operation of the assemblies associated with the source group.	<a href="#">Page 5-6</a>
<a href="#">Signal Separation Group Operation</a>	Operation of the assemblies associated with signal separation, including the operation of Option 014.	<a href="#">Page 5-16</a>
<a href="#">Receiver Group Operation</a>	Operation of the assemblies associated with the receiver group.	<a href="#">Page 5-21</a>
<a href="#">Frequency Offset Group Operation (Options 080 and 081)</a>	Operation of the assemblies associated with frequency offset mode of operation.	<a href="#">Page 5-24</a>
<a href="#">IF Access Group (Option H11)</a>	Operation of the assemblies associated with Option H11, IF access.	<a href="#">Page 5-26</a>
<a href="#">Digital Processing and Digital Control Group Operation</a>	Operation of the assemblies associated with digital processing and control.	<a href="#">Page 5-28</a>
<a href="#">Power Supply Group Operation</a>	Operation of the power supply assembly group.	<a href="#">Page 5-33</a>

## Network Analyzer System Operation

The PNA series network analyzer generates a phase-locked incident signal from the internal synthesized source. By means of signal separation, the incident signal is divided into a reference signal and a test signal. The reference signal is applied to the receiver group, while the test signal is applied to the device under test (DUT) and then to the receiver group. The signals are downconverted and are next sampled and digitally processed. Figure 5-1 is a simplified block diagram of the network analyzer system.

Figure 5-1 System Simplified Block Diagram

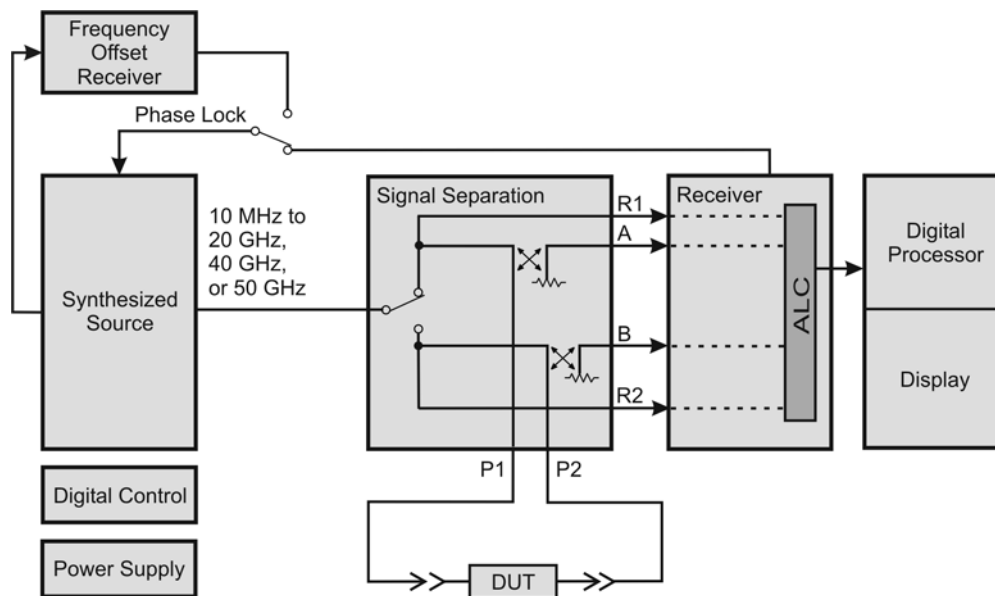

st513b

## Functional Groups of the Network Analyzer

The operation of the network analyzer can be separated into six functional groups. Each group consists of several major assemblies that perform a distinct function in the instrument. Some of the assemblies are related to more than one group, and all the groups, to some extent, are interrelated and affect each other's performance. The six major functional groups are:

- Synthesized Source Group
- Signal Separation Group
- Receiver Group
- IF Access Group
- Frequency Offset Group
- Digital Processor and Digital Control Group
- Power Supply Group

### Synthesized Source Group

The built-in synthesized source generates a swept, stepped, or continuous wave (CW) signal in the frequency ranges as listed in [Table 5-1](#). The source output power is leveled by an internal automatic leveling control (ALC) circuit. In the standard analyzer, a portion of the source signal is routed to one of the reference receivers (R1 or R2), and fed back to the source for phase lock. In the Option 080 (frequency offset mode) analyzer, a portion of the source signal is routed to a frequency offset receiver to provide the phase lock signal. The maximum output power level of the network analyzer at the test ports is shown in [Table 5-1](#).

The operation of the source functional group is described in [“Source Group Operation”](#) on page 5-6.

**Table 5-1 Frequency Range and Maximum Output Power Level**

Frequency Range	10 MHz to 45 MHz	45 MHz to 10 GHz	10 GHz to 20 GHz	20 GHz to 30 GHz	30 GHz to 40 GHz	40 GHz to 45 GHz	45 GHz to 50 GHz
<b>Max. Pwr. Out</b>							
Standard	+2 dBm	+5 dBm	+3 dBm	0 dBm	-4 dBm	-5 dBm	-10 dBm
Opt. 014	+2 dBm	+5 dBm	+2 dBm	-2 dBm	-6 dBm	-7 dBm	-12 dBm
Opt. UNL	0 dBm	+3 dBm	+1 dBm	-2 dBm	-6 dBm	-9 dBm	-15 dBm
Opt. UNL/014	0 dBm	+3 dBm	0 dBm	-4 dBm	-8 dBm	-11 dBm	-17 dBm

### Signal Separation Group

The source signal is separated into a reference path and a test path. The reference signal is transmitted to the receiver group. The test signal is transmitted through—and reflected from—the DUT and then is transmitted to the receiver group.

Hardware options added to the analyzer also provide attenuation for the test signals, RF path switching to allow forward and reverse measurements, and external connections for the DUT.

Refer to [“Signal Separation Group Operation”](#) on page 5-16.

### Receiver Group

The receiver converts the test signal to a 41 kHz intermediate frequency (IF) for signal processing, retaining both magnitude and phase characteristics. The IF signal is converted to a digital signal by the digital processing group.

Refer to [“Receiver Group Operation”](#) on page 5-21.

### Frequency Offset Group

This group provides the phase lock needed for frequency offset mode (Option 080), where the source and receivers are tuned to different frequencies.

It also provides reference signal transfer switches in the channel R1 reference path for automatically adding or removing an external reference mixer in the measurement setup.

Refer to [“Frequency Offset Group Operation \(Options 080 and 081\)”](#) on page 5-24.

### IF Access Group

This group provides the circuitry needed for the IF access (Option H11) capability.

Option H11 is also necessary for the operation of the pulse measurement capability, Option H08.

Refer to [“IF Access Group \(Option H11\)”](#) on page 5-26.

### **Digital Processor and Digital Control Group**

The digital processor and digital control group are divided into a front panel group and a data acquisition and processing group. The front panel group provides communication to the network analyzer. The data acquisition and processing group provides signal processing and analyzer control, and output to the display.

Refer to [“Digital Processing and Digital Control Group Operation”](#) on page 5-28.

### **Power Supply Group**

The power supply functional group provides power for the other assemblies in the instrument.

Refer to [“Power Supply Group Operation”](#) on page 5-33.

---

## Source Group Operation

The source group produces a stable output signal by phase locking a yttrium-iron-garnet (YIG) oscillator to a synthesized voltage-controlled oscillator (VCO). Refer to [Table 5-2 on page 5-8](#) for the full frequency range of the source. The outputs at the front panel test ports are swept, stepped or CW signals. Maximum leveled output powers are listed in [Table 5-1 on page 5-4](#). For a simple block diagram of the source group, refer to [Figure 5-2](#).

The following are described in this section:

- [Band Modes](#)
- [A8 Fractional-N Synthesizer Board](#)
- [A17 L.O. Multiplier/Amplifier 10 \(LOMA 10\)](#)
- [A18 Multiplier/Amplifier 20 \(MA 20\)](#)
- [A19 Splitter](#)
- [A20 L.O. Distribution Assembly \(LODA\)](#)
- [A10 Frequency Reference Board](#) (including rear-panel interconnects)
- [A11 Phase Lock Board](#)
- [A12 Source 20](#)
- [A21 Source Multiplier/Amplifier 50 \(SOMA 50\) \(E8363C and E8364C Only\)](#)
- [A16 Test Set Motherboard](#) (including rear-panel interconnects)

### Band Modes

[Table 5-2 on page 5-8](#) lists the L.O. harmonic number, the synthesizer frequency, the source frequency, and the frequencies at various other locations within the analyzer for each band. This table is referred to throughout this chapter and also appears on the overall block diagram at the end of [Chapter 4](#), “[Troubleshooting](#).”

The A10 frequency reference board produces a constant phase locked reference signal of 8.333 MHz (1.0416 MHz for Band 0) which is sent to the A11 phase lock board.

The A8 fractional-N synthesizer board produces an LO signal which is sent through the A17–A20 LO distribution path to the A27–A30 first converters. The frequency is synthesized such that the mixing product of this LO signal with the main source output is a constant 8.333 MHz. In the A31–A34 receiver modules, this 1st IF signal is mixed with the 2nd LO signals to produce a constant 2nd IF signal at 41.667 kHz.

A portion of the 1st IF signal is passed through the phase lock multiplexer on the A16 test set motherboard back to the A11 phase lock board to complete the phase lock loop. For Option 080 (frequency offset mode), this phase lock signal comes from the A13 frequency offset receiver. Refer to “[Frequency Offset Group Operation \(Options 080 and 081\)](#)” on [page 5-24](#).

The A10 frequency reference board also produces a constant 33.1667 MHz signal which is passed to the A35 receiver motherboard where the frequency is divided by four to produce a constant 2nd LO signal of 8.29167 MHz. It is then divided into two signals, the 2nd LO (a) and the 2nd LO (b). The 2nd LO (b) signal is phase shifted +90° relative to 2nd LO (a). Both of these signals are then distributed to each of the four receiver modules.

**Figure 5-2 Source Group**

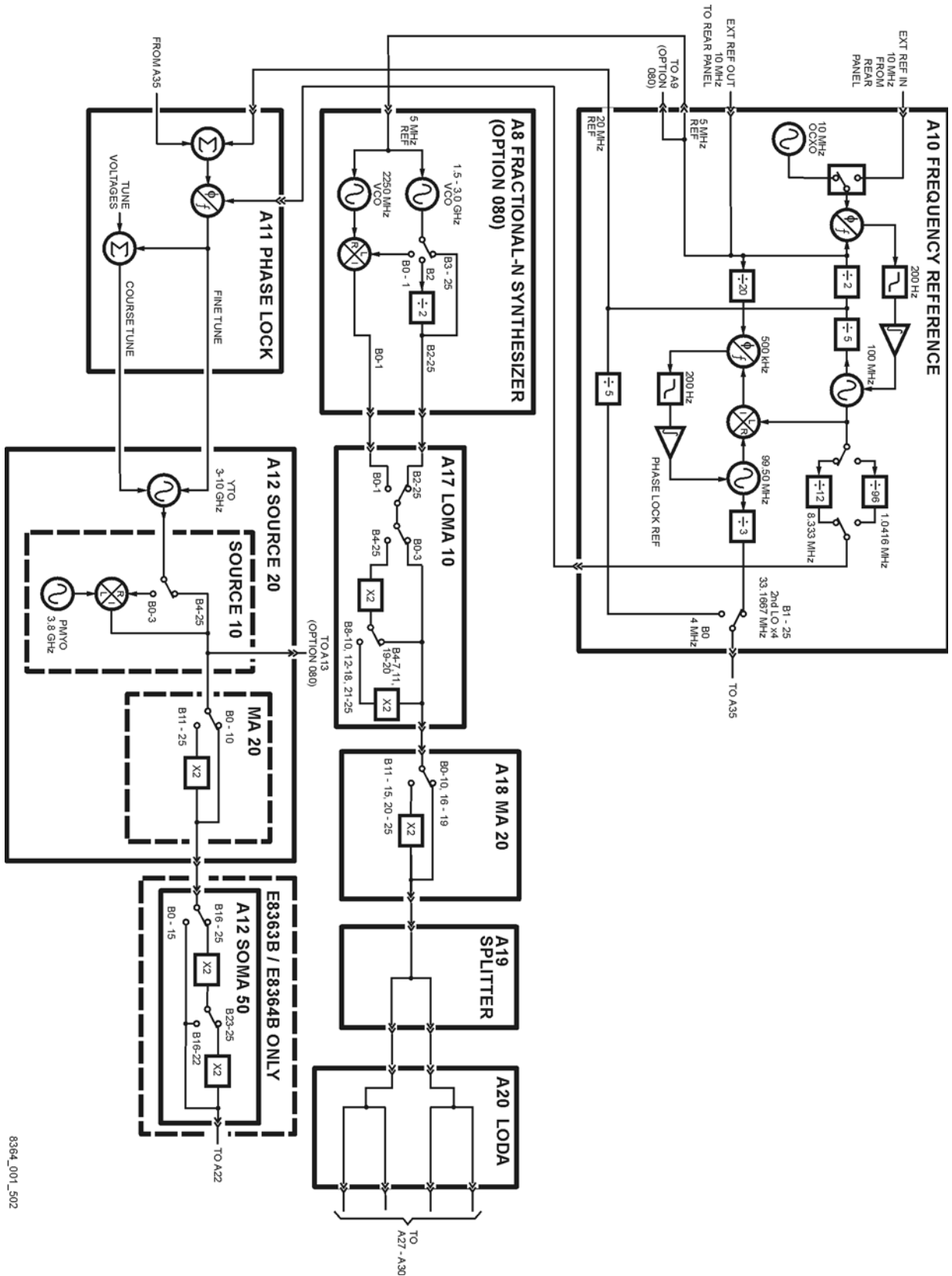

8364\_001\_502

**Table 5-2 Subsweep Frequencies**

Model	Band	L.O. Harmonic Number (N)	A8 Frac-N Synthesizer Frequency (GHz)	A17 LOMA 10 Frequency (GHz)	A20 LODA (L.O.) Frequency (GHz)	A12 Source 20 Frequency (GHz)	A21 SOMA 50 Frequency (GHz) (E8363/4C Only)
E8362C, E8363C, E8364C	0	1	0.011 to 0.046	0.011 to 0.046	0.011 to 0.046	0.010 to 0.045	0.010 to 0.045
	1	1	0.053 to 0.756	0.053 to 0.756	0.053 to 0.756	0.045 to 0.748	0.045 to 0.748
	2	1	0.756 to 1.508	0.756 to 1.508	0.756 to 1.508	0.748 to 1.500	0.748 to 1.500
	3	1	1.50 to 3.00	1.50 to 3.00	1.50 to 3.00	1.50 to 3.00	1.50 to 3.00
	4	1	1.50 to 1.90	3.00 to 3.80	3.00 to 3.80	3.00 to 3.80	3.00 to 3.80
	5	1	1.90 to 2.25	3.80 to 4.50	3.80 to 4.50	3.80 to 4.50	3.80 to 4.50
	6	1	2.25 to 2.40	4.50 to 4.80	4.50 to 4.80	4.50 to 4.80	4.50 to 4.80
	7	1	2.40 to 3.00	4.80 to 6.00	4.80 to 6.00	4.80 to 6.00	4.80 to 6.00
	8	1	1.50 to 1.60	6.00 to 6.40	6.00 to 6.40	6.00 to 6.40	6.00 to 6.40
	9	1	1.60 to 1.90	6.40 to 7.60	6.40 to 7.60	6.40 to 7.60	6.40 to 7.60
	10	1	1.90 to 2.50	7.60 to 10.00	7.60 to 10.00	7.60 to 10.00	7.60 to 10.00
	11	1	2.50 to 3.00	5.00 to 6.00	10.00 to 12.00	10.00 to 12.00	10.00 to 12.00
	12	1	1.50 to 1.60	6.00 to 6.40	12.00 to 12.80	12.00 to 12.80	12.00 to 12.80
	13	1	1.60 to 1.90	6.40 to 7.60	12.80 to 15.20	12.80 to 15.20	12.80 to 15.20
	14	1	1.90 to 2.00	7.60 to 8.00	15.20 to 16.00	15.20 to 16.00	15.20 to 16.00
15	1	2.00 to 2.50	8.00 to 10.00	16.00 to 20.00	16.00 to 20.00	16.00 to 20.00	
E8363C, E8364C	16	3	1.67 to 1.90	6.67 to 7.60	6.67 to 7.60	10.00 to 11.40	20.00 to 22.80
	17	3	1.90 to 2.13	7.60 to 8.53	7.60 to 8.53	11.40 to 12.80	22.80 to 25.60
	18	3	2.13 to 2.50	8.53 to 10.00	8.53 to 10.00	12.80 to 15.00	25.60 to 30.00
	19	3	2.50 to 2.67	5.00 to 5.33	10.00 to 10.67	15.00 to 16.00	30.00 to 32.00
	20	3	2.67 to 3.00	5.33 to 6.00	10.67 to 12.00	16.00 to 18.00	32.00 to 36.00
	21	3	1.50 to 1.60	6.00 to 6.40	12.00 to 12.80	18.00 to 19.20	36.00 to 38.40
	22	3	1.60 to 1.67	6.40 to 6.67	12.80 to 13.33	19.20 to 20.00	38.40 to 40.00
E8364C	23	3	1.67 to 1.90	6.67 to 7.60	13.33 to 15.20	10.00 to 11.40	40.00 to 45.60
	24	3	1.90 to 2.00	7.60 to 8.00	15.20 to 16.00	11.40 to 12.00	45.60 to 48.00
	25	3	2.00 to 2.08	8.00 to 8.33	16.00 to 16.67	12.00 to 12.50	48.00 to 50.00

### A8 Fractional-N Synthesizer Board

The A8 fractional-N synthesizer board uses the 5 MHz reference signal from the A10 frequency reference board to tune two VCO circuits: one that sweeps from 1500 to 3010 MHz and one that is set to a CW frequency of 2250 MHz. In bands 0–1, these two signals are heterodyned to produce the output frequencies listed in [Table 5-2](#). In band 2, the output of the swept VCO is passed through a divide-by-2 circuit to produce the output frequencies listed in [Table 5-2](#). In all other bands, the swept VCO signal is sent directly to the synthesizer output.



At the output, an ALC circuit maintains the power level at  $-5 \text{ dBm} \pm 2 \text{ dB}$  for bands 0–1 or  $-1.5 \text{ dBm} \pm 2 \text{ dB}$  for bands 2–25. In all bands, the output is sent to the A17–A20 LO distribution path and on to the A27–A30 first converters, as the 1st LO signal.

### **A17 L.O. Multiplier/Amplifier 10 (LOMA 10)**

In bands 0–3, the input signal from the A8 fractional-N synthesizer board is passed through the A17 LOMA 10 unchanged. For all other bands, the signals are doubled, filtered, and amplified. In bands 8–10, 12–18, and 21–25, the signals are again doubled, filtered, and amplified. Together, all of these signal paths create the full output frequency range of 11 MHz to 10 GHz.

### **A18 Multiplier/Amplifier 20 (MA 20)**

In bands 0–10 and 16–18, the 11 MHz to 10 GHz input frequencies are filtered, amplified, and passed through the A18 MA 20. In bands 11–15, and 19–25, the signals are doubled, filtered, and amplified.

Together, these signal paths create the full output frequency range of 11 MHz to 20 GHz that is sent to the A19 splitter.

### **A19 Splitter**

The A19 splitter receives the 11 MHz to 20 GHz LO signal from the A8, A17, and A18 LO generation chain and divides it into two signals which are routed to the A20 L.O. distribution assembly (LODA). This splitter configuration provides the highest level of balance and control of the LO signal.

### **A20 L.O. Distribution Assembly (LODA)**

In the A20 LODA, the LO signal is amplified and split to provide balanced LO signals to each of the A27–A30 receiver first converters.

### **A10 Frequency Reference Board**

This assembly provides stable reference frequencies to the rest of the instrument. A high stability 10 MHz oven-controlled crystal oscillator (OCXO) normally provides the frequency standard. However, if a 10 MHz external reference signal is detected at the 10 MHz EXT REF IN port on the rear panel, it is used as the frequency reference instead.

The 10 MHz reference signal is used to phase lock a 100 MHz VCO. This VCO is then used to phase lock a second VCO at 99.5 MHz. It is also used to provide the 10 MHz EXT REF OUT rear panel signal, reference for the A11 phase lock board, and a 5 MHz reference for the A6 signal processing ADC module (SPAM) board, the A8 fractional-N synthesizer board, and the A9 fractional-N synthesizer board (Option 080 only).

The 95.5 MHz reference signal is sent through a divide-by-3 circuit to produce the fourth multiple of the 8.29167 MHz 2nd LO signal which is sent to the A35 receiver motherboard. The 100 MHz reference signal is sent through a divide-by-12 circuit to produce the 8.3333 MHz phase lock reference signal which is sent to the A11 phase lock board.

## Rear-Panel Interconnects

<b>10 MHz REF. INPUT</b>	A BNC connector that allows an external frequency reference signal to be used to phase lock the analyzer for increased frequency accuracy.  The analyzer automatically enables the external frequency reference feature when a signal is connected to this input. When the signal is removed, the analyzer automatically switches back to its internal frequency reference.
<b>10 MHz REF. OUTPUT</b>	A BNC connector that allows a 10 MHz reference signal, produced by the A10 frequency reference board, to be output for use in phase locking external test equipment.

## A11 Phase Lock Board

The A11 phase lock board compares the phase lock IF signal from the A16 test set motherboard with the phase lock reference signal from the A10 frequency reference board to generate the tuning voltage for the A12 source 20 YIG-tuned oscillator (YTO). In addition, various digital-to-analog converters (DACs) on this assembly are set by the A6 SPAM board to inject offset and delay voltages for the various source bands and measurement sweep rates.

## A12 Source 20

The A12 source 20 consists of:

- [Source 10](#)
- [Multiplier/Amplifier 20 \(MA 20\)](#)
- [ALC Circuitry](#)

### Source 10

The A12 source 20 contains a 3–10 GHz YIG-tuned oscillator (YTO) and a fixed frequency 3.8 GHz permanent-magnet YIG oscillator (PMYO).

The YTO has a main coil and an FM coil. These are analogous to the woofer and the tweeter in a stereo speaker: the woofer reproduces low frequencies and the tweeter reproduces high frequencies. Similarly in the YTO, the main coil allows large, slow changes in frequency but cannot respond to high frequency deviations, which are sent to the faster-acting FM coil.

The tune current from the A11 phase lock board splits into two paths. One path is low-pass filtered, removing high frequency components, and goes to the YTO main coil; the other path is highpass filtered, removing low frequency components, and goes to the YTO FM coil. The filters are matched in stop-band response, such that one picks up where the other leaves off.

The frequency of the PMYO is set by a voltage received from a DAC set by the A6 SPAM board.

In bands 0–3, the 3.810 to 6.8 GHz output of the YTO and the 3.8 GHz output of the PMYO are mixed to produce the 10 MHz to 3.0 GHz output frequency that is sent to the multiplier/amplifier 20 (MA 20). In bands 4–25, the 3 to 10 GHz output of the YTO is filtered and sent directly to the MA 20.

An additional signal is split off from the output signal and routed to the [A13 Frequency Offset Receiver Assembly \(Option 080\)](#) where it is used to create the phase lock signal for the frequency offset mode of operation (Option 080). Refer to [Frequency Offset Group Operation \(Options 080 and 081\)](#).

### **Multiplier/Amplifier 20 (MA 20)**

The MA 20 filters, amplifies, and passes through, the 10 MHz to 10 GHz output frequencies in bands 0–10. The signals for bands 11–25 are doubled, filtered, and amplified. Together, these two paths produce an output frequency range of 10 MHz to 20 GHz.

For the E8362C analyzer, this signal is sent directly to the A22 switch splitter in the signal separation group.

For the E8363C and E8364C analyzers, this signal is sent to the A21 source multiplier/amplifier 50 (SOMA 50).

A portion of this output signal is split off and combined with other inputs in the ALC circuitry to control the output power level.

### **ALC Circuitry**

The following inputs are combined in the ALC circuitry to produce a signal that is sent to the MA20 to control its output power level:

- output of the MA 20
- temperature compensation
- slope compensation
- power level DAC
- 1V/GHz signal from the A11 phase lock board

### **A21 Source Multiplier/Amplifier 50 (SOMA 50) (E8363C and E8364C Only)**

The A21 SOMA 50 consists of three signal paths:

- In the first path, the 10 MHz to 20 GHz source signals for bands 0–15 are amplified, leveled, and passed through to the A22 switch splitter.
- In the second path, the 10 to 20 GHz signals for bands 16–22 are doubled, filtered, and amplified to produce the 20 to 40 GHz output.
- In the third path (E8364C only), a portion of the second-path signal is doubled to produce the 40 to 50 GHz output for bands 23–25.

The source ALC circuitry (located on the A16 test set motherboard) provides feedback to the SOMA 50 to control the output power level.

## A16 Test Set Motherboard

The A16 test set motherboard serves these functions:

- to act as an interface between the A15 CPU board and the auxiliary rear panel interconnects.
- to provide ALC signals to the A21 SOMA 50 and to the A18 multiplier/amplifier.
- to route control signals to the signal separation group. Refer to “Signal Separation Group Operation” on page 5-16 for more information.

### Rear Panel Interconnects

The A16 test set motherboard includes the following rear panel interconnects.

<b>TEST SET I/O</b>	<p>A DB-25 female connector that is used to control external test sets. The external test set bus consists of 13 multiplexed address and data lines, three control lines, and an open-collector interrupt line. Pin assignments are listed in <a href="#">Table 5-3 on page 5-13</a>.</p> <p>Up to 16 test sets may be “daisy-chained” on the bus at one time.</p> <p>The Test Set I/O is not compatible with 8753 network analyzer test sets.</p>
<b>HANDLER I/O</b>	<p>A rectangular 36-pin, female connector providing four independent parallel input/output ports, nine control signal lines, one ground, and a power supply line. This connector has Type 2 output pin assignments as listed in <a href="#">Table 5-4 on page 5-14</a>.</p> <p>All signals are TTL-compatible. Data input/output ports consist of two 8-bit output ports (Port A and Port B) and two 4-bit bidirectional ports (Port C and Port D).</p> <p>Connector settings can be changed using SCPI and COM commands. The settings are not accessible from the front panel.</p>
<b>AUX I/O</b>	<p>A DB-25 male connector that provides a variety of both analog and digital input and output signals as described in <a href="#">Table 5-5 on page 5-15</a>.</p>
<b>I/O 1 (TRIG IN)</b>	<p>A BNC connector for input of an external trigger. The analyzer can be triggered by an external device using this input. This is the same signal that appears on AUX I/O pin 19 as described in <a href="#">Table 5-5 on page 5-15</a>.</p>
<b>I/O 2 (TRIG OUT)</b>	<p>A BNC connector for output of a trigger signal. This trigger signal can be used to trigger external devices used in the measurement setup, such as signal generators.</p>

**Table 5-3 TEST SET I/O Connector Pin Assignments**

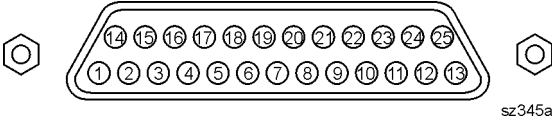

**DB-25 Female Connector**

Pin Numbers	Name	Function
1	SEL0	TTL out, test set select bit 0, tied to 0 V
2	Sweep Holdoff In	TTL in, low level holds off sweep
3–6	AD12–AD8	TTL I/O, address and latched data
7	GND	0 V, ground reference
8	LAS	TTL out, active low address strobe (1 $\mu$ s min)
9–11	AD4–AD2	TTL I/O, address and latched data
12	GND	0 V, ground reference
13	Interrupt In	TTL in, low level (10 $\mu$ s min) aborts sweep
14	+22 V	+22 Vdc, 100 mA max.
15–16	SEL1–2	TTL out, test set select bits 1-2, tied to 0 V
17	AD11	TTL I/O, address and latched data
18	SEL3	TTL out, test set select bit 3, tied to 0 V
19–21	AD7–5	TTL I/O, address and latched data
22–23	AD0–1	TTL I/O, address and latched data
24	LDS	TTL out, active low data strobe (1 $\mu$ s min)
25	RLW	TTL out, high = read, low = write

**Table 5-4 HANDLER I/O Connector Key Pin Assignments**

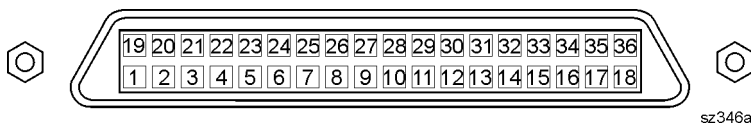

**Rectangular 36-Pin Female Connector**

Pin Numbers	Name	Function
1	GND	0 V, ground reference
2	INPUT1	TTL in, negative pulse (1 $\mu$ s min) latches OUTPUT1-2
3-4	OUTPUT1-2	TTL out, latched
5-12	Port A0-7 Out	TTL out, latched
13-20	Port B0-7 Out	TTL out, latched
21-24	Port C I/O	TTL I/O, latched
25-28	Port D I/O	TTL I/O, latched
29	Port C Status	TTL out, low = input mode, high = output mode
30	Port D Status	TTL out, low = input mode, high = output mode
31	Output Strobe Write Strobe	TTL out, active low data write strobe (1 $\mu$ s min)
32	No connect	Not used
33	Pass Fail	TTL out, latched, indicates pass fail (programmable polarity)
34	+5 V	+5 Vdc, 100 mA max.
35	Sweep End	TTL out, active low (10 $\mu$ s min) indicates sweep done
36	Pass/Fail Write Strobe	TTL out, active low pass/fail write strobe (1 $\mu$ s min)

**Table 5-5 AUX I/O Connector Pin Assignments**

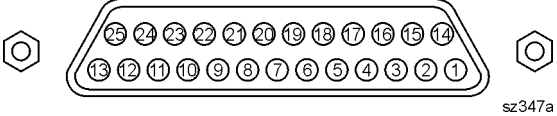

**DB-25 Male Connector**

Pin Numbers	Name	Function
1	ACOM	0 V, ground reference for analog signals
2–3	Analog Out 2–1	–10 to +10 Vdc output, 10 mA max, $R_o = 100\ \Omega$
4	No connect	For future enhancements
5	DCOM	0 V, ground reference for digital signals
6–8	Pulse Out 3–1	TTL out, programmable pulse (for future use)
9	+5 V	+5 Vdc output, 100 mA max.
10	Pass/Fail Write Strobe	TTL out, active low (1 $\mu$ s min) indicates pass/fail line is valid
11	Sweep End	TTL out, active low (10 $\mu$ s min) indicates sweep is done
12	Pass/Fail	TTL out, latched, indicates pass or fail (programmable polarity)
13	Output Port Write Strobe	TTL out, active low (10 $\mu$ s min) writes I/O port data
14	Analog In	–10 to +10 Vdc input, $R_i = 100\text{k}\ \Omega$
15	ACOM	0 V, ground reference for analog signals
16	Power Button In	Open-collector input, active low replicates a power button press
17	DCOM	0 V, ground reference for digital signals
18	Ready for Trigger	TTL out, low indicates ready for external trigger
19	External Trigger In	TTL in, level trigger (width >1 ms), programmable polarity
20	Footswitch In	TTL in, active low (width >1 ms), triggers a programmable event
21	+22 V	+22 Vdc output, 100 mA max.
22–25	In/Out Port C0–3	TTL I/O, general purpose

---

## Signal Separation Group Operation

The signal separation group divides the source signal into a reference path and a test path. Refer to [Figure 5-3 on page 5-17](#).

- The reference signal is transmitted to the receiver group.
- The test signal is transmitted through—and reflected from—the device under test (DUT) and then is transmitted to the receiver group.
- Control lines to this group are routed from the A16 test set motherboard.

In this section, the following assemblies are described:

- [A22 Switch Splitter](#)
- [A25 and A26 Test Port Couplers](#)
- [A23 and A24 Detectors \(E8363C and E8364C Only\)](#)
- [30-dB Fixed Attenuators \(E8362C Only\)](#)
- [A36 and A37 60-dB Source Step Attenuators \(Option UNL\)](#)
- [A38 and A39 Bias Tees \(Option UNL\)](#)
- [A43 and A44 35-dB Receiver Step Attenuators \(Option 016\)](#)
- [Front Panel Jumpers \(Option 014 Configurable Test Set\)](#)

### A22 Switch Splitter

For the E8363C and E8364C, the output of the A21 SOMA 50 is routed to the A22 switch splitter. For the E8362C, this is the output of the A12 source 20 assembly. The A22 switch splitter is a solid-state switch. It switches between the Port 1 and Port 2 measurement paths, automatically enabling alternate forward and reverse measurements. The A22 switch splitter provides an internal termination for the measurement port that is inactive.

Each measurement path in the A22 switch splitter includes a two-way splitter; the signal is split into the test port signal and the receiver signal.

The test port signal is sent directly through the test port coupler, A25 or A26, and out through either PORT 1 or PORT 2 to the DUT, unless Option UNL is installed. In this case, the signal is routed through the step attenuator, A36 or A37, the bias tee, A38 or A39, then through the test port coupler and test port to the DUT.

The reference signal is routed to the appropriate R channel receiver module, A32 or A33, through a detector, A23 or A24 (for E8363C and E8364C), or a 30-dB fixed attenuator (for E8362C), and a receiver first converter, A28 or A29. If Option 014 is installed, the signal is routed through a front-panel channel R jumper to the receiver first converter.



**Figure 5-3 Signal Separation Group, Standard Analyzer**

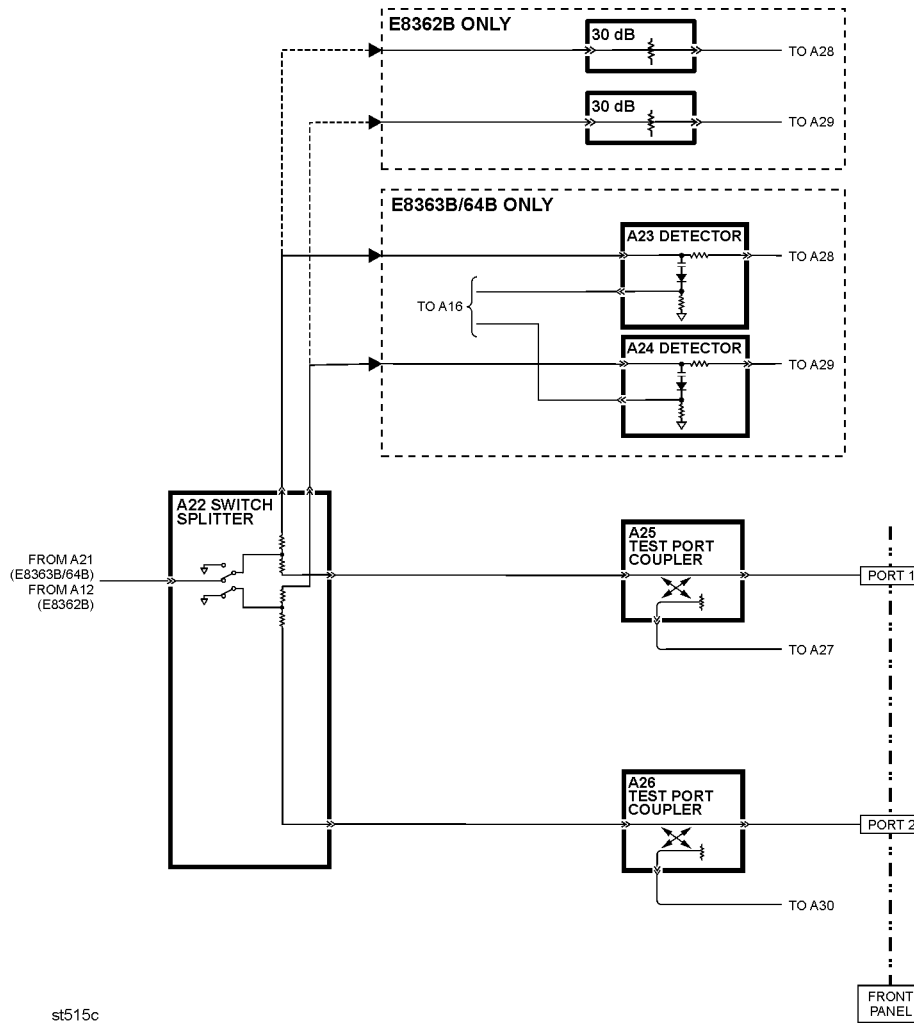

### A25 and A26 Test Port Couplers

The test port signal goes into the through-line arm of the couplers, and from there to the test ports and the DUT. The coupled arm of the couplers carries the signal reflected from or transmitted through the DUT, to the receiver (through a front panel jumper for Option 014) for measurement. The coupling coefficient of the directional couplers is nominally 15 dB over the full frequency range.

### A23 and A24 Detectors (E8363C and E8364C Only)

The A23 and A24 detectors sense the R1 and R2 reference signal levels and provide feedback to the ALC circuitry on the A16 test set motherboard.

### 30-dB Fixed Attenuators (E8362C Only)

The 30-dB fixed attenuators are placed in the reference signal paths to provide isolation. The source power output is sufficiently stable over this frequency range that ALC feedback is not necessary.

### **A36 and A37 60-dB Source Step Attenuators (Option UNL)**

The 60-dB step attenuators provide coarse power control for the test port signals. They are electro-mechanical step attenuators that provide 0 to 60 dB of attenuation in 10-dB steps. These attenuators are controlled by the A15 CPU board. They adjust the power level to the DUT without changing the level of the incident power in the reference path.

### **A38 and A39 Bias Tees (Option UNL)**

The A38 and A39 bias tees provide a means of biasing active devices with an external dc voltage connected to the rear-panel DC BIAS CONNECT ports. The dc voltage is applied directly to the center conductor of the test port connectors. A blocking capacitor ensures that the dc bias current goes only to the DUT, and not back into the source. Similarly, an inductor in the bias path prevents RF from being imposed on the external dc supply.

### **A43 and A44 35-dB Receiver Step Attenuators (Option 016)**

These 35-dB step attenuators provide coarse power control for amplified input. They are electro-mechanical step attenuators that provide 0 to 35 dB of attenuation in 5-dB steps. These attenuators are controlled by the A15 CPU board.

### **Option 014 Configurable Test Set**

The Option 014 analyzer allows you to measure devices with higher power and higher dynamic range limits than the standard analyzer. The theory of operation is the same as for the standard analyzer except that there are six front panel SMA jumpers.

As shown in [Figure 5-4 on page 5-19](#), these jumpers allow access to the test port and reference signals between:

- the A22 switch splitter and the A25 test port 1 coupler. (For Option UNL, this is between the A36 step attenuator and the A38 bias tee.)
- the A22 switch splitter and the A26 test port 2 coupler, (For Option UNL, this is between the A37 step attenuator and the A39 bias tee.)
- the A25 test port 1 coupler and the A27 receiver A first converter
- the A26 test port 2 coupler and the A30 receiver B first converter
- the A23 detector (for E8363C and E8364C) or fixed attenuator (for E8362C) and the A28 receiver R1 first converter
- the A24 detector (for E8363C and E8364C) or fixed attenuator (for E8362C) and the A29 receiver R2 first converter

**Normal Option 014 Configuration**

The normal configuration for the Option 014 is shown in Figure 5-4 on page 5-19. With this configuration and inclusion of an external amplifier and accessories, you can calibrate the analyzer and test devices at power levels up to +30 dBm. You can make measurements in the forward, reverse or both directions and still achieve these high power levels. For more information on higher power measurements, search for “Option 014” in the embedded help index in the analyzer.

**Figure 5-4 Signal Separation Group, Option 014 Analyzer**

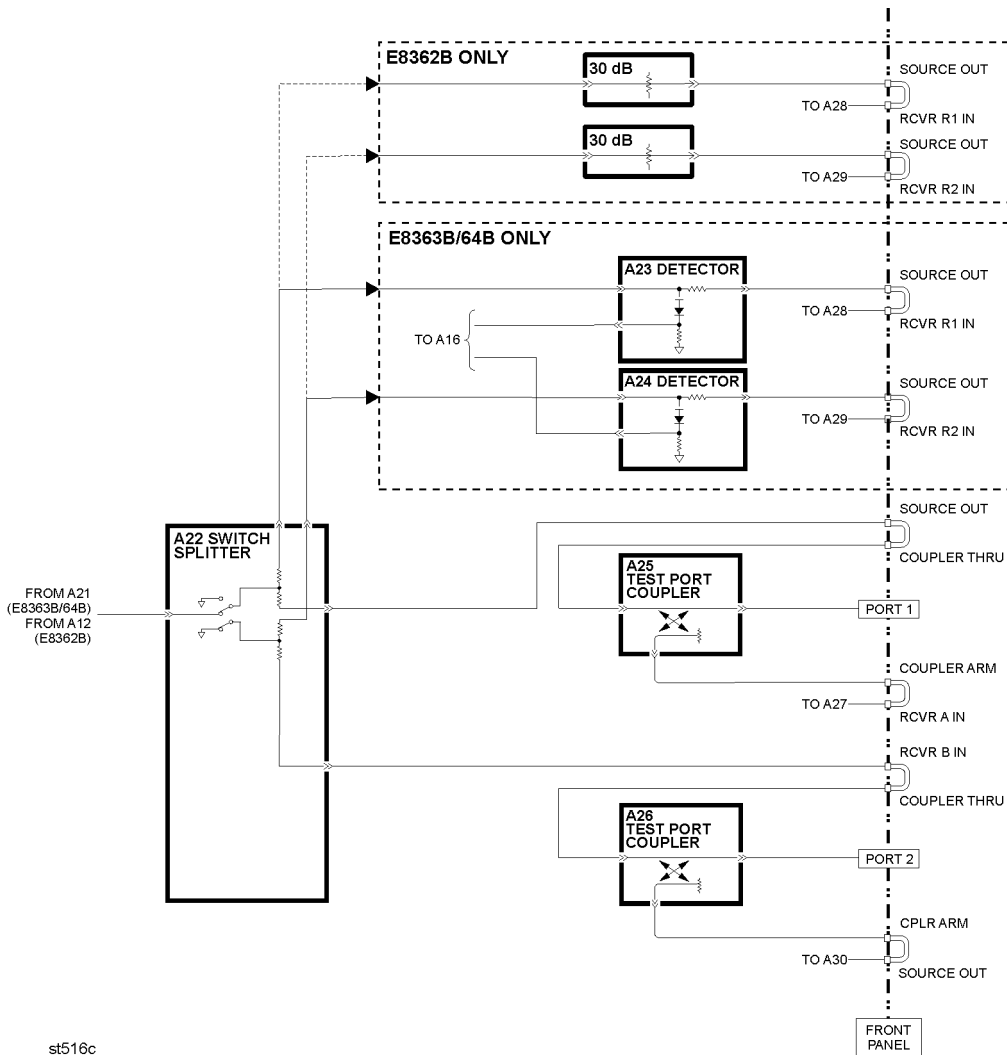

**High Dynamic Range Configuration**

With a few jumper changes, you can configure the Option 014 for higher dynamic range measurements. By

swapping the front panel jumpers for one port, signal flow through the corresponding coupler is reversed, increasing the test signal sensitivity by 15 dB.

In the forward direction, as shown in Figure 5-5, the signal flow through the test port coupler (A26) is reversed by arranging the front panel jumpers such that RCVR B IN connects to CPLR THRU and CPLR ARM connects to SOURCE OUT.

In the reverse direction, not shown, the signal flow through the test port coupler (A25) is reversed by arranging the front panel jumpers such that RCVR A IN connects to CPLR THRU and CPLR ARM connects to SOURCE OUT.

For more information on high dynamic range measurements and configurations, search for “Option 014” in the embedded help index in the analyzer.

**Figure 5-5 High Dynamic Range Configuration in the Forward Direction**

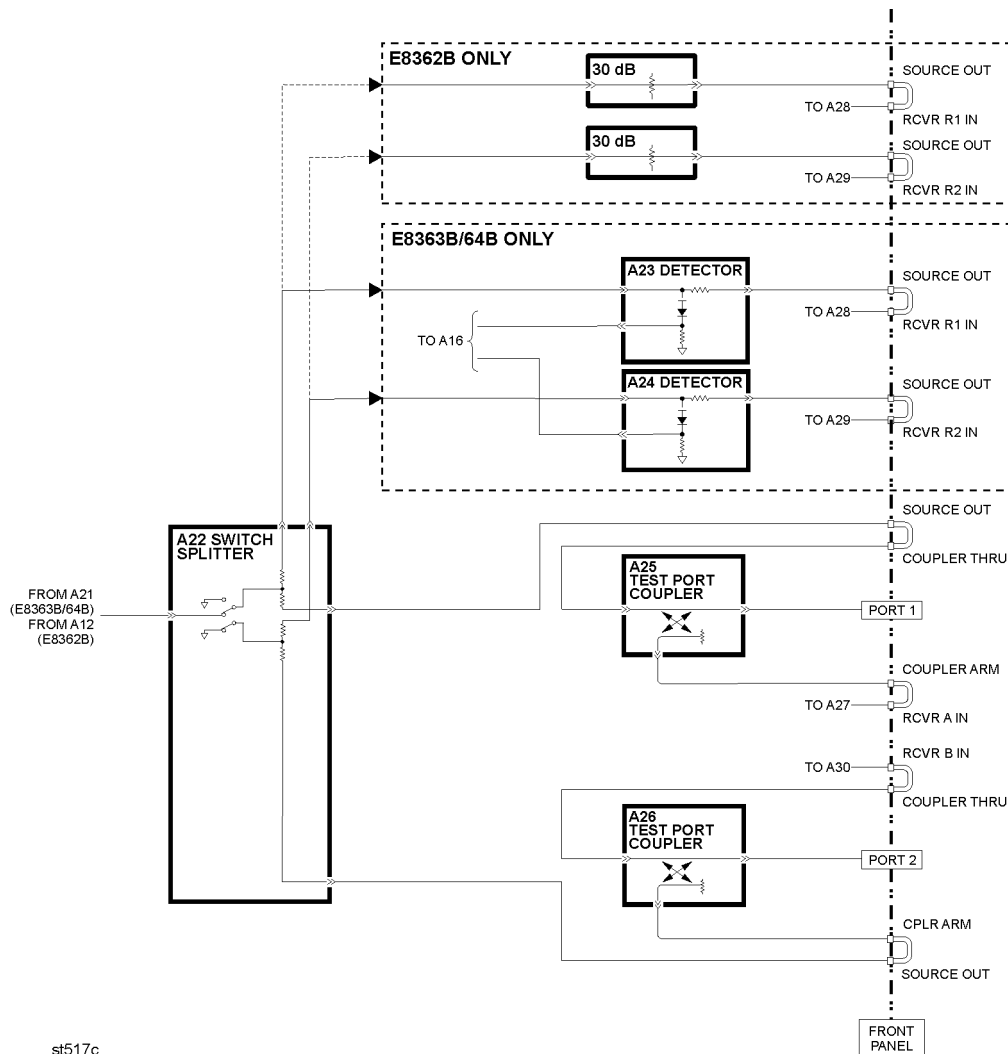

st517c

---

## Receiver Group Operation

The receiver group measures and processes the input signals into digital information for processing and eventual display. [Figure 5-6 on page 5-22](#) is a simplified block diagram of the receiver functional group.

In this section the following assemblies are described:

- [A27, A28, A29, and A30 Receiver First Converters \(Mixers\)](#)
- [A49 IF Multiplexer Board](#)
- [A31, A32, A33, and A34 Receiver Modules](#)
- [A6 SPAM Board \(Analog Description\)](#)
- [A35 Receiver Motherboard](#)
- [A16 Test Set Motherboard](#)

### A27, A28, A29, and A30 Receiver First Converters (Mixers)

The four receiver first converters (mixers) function identically and are completely interchangeable.

Each first converter receives the RF reference or test signal and mixes it with the 1st LO signal from the A20 LODA to create the 1st IF signal at a constant 8.333 MHz for bands 1–25 or 1.0416 MHz for band 0. This 1st IF signal is sent to the LO reject/filter board.

### A49 IF Multiplexer Board

In each of the four channels, a 3 MHz lowpass filter is switched into the signal path for band 0, to allow only the 1st IF signal of 1.0416 MHz to pass but higher frequencies to be blocked. See [“IF Access Group \(Option H11\)” on page 5-26](#) also.

### A31, A32, A33, and A34 Receiver Modules

The four receiver modules function identically and are completely interchangeable.

The 8.333 MHz 1st IF signal is filtered and amplified. For bands 16-25, additional amplification is applied to overcome conversion loss of the A27–A30 first converters in their third-order conversion mode.

A portion of the 8.333 MHz 1st IF signal is sent to a multiplexer on the A35 receiver motherboard, the output of which is routed to the A11 phase lock board to complete the phase lock loop. The 8.333 MHz 1st IF signal is also filtered, amplified, and routed to the 2nd converter.

The 2nd converter divides the 8.333 MHz signal into two paths and mixes each with a separate LO signal, designated 2nd LO (a) and 2nd LO (b). Both of these 2nd LO signals are 1.000 MHz (for Band 0) or 8.29167 MHz (for Bands 1-25). The 2nd LO (b) signal is phase shifted  $+90^\circ$  relative to the 2nd LO (a) signal. These two generated 2nd IF signals are a constant 41.667 kHz. These 2nd IF (a) and 2nd IF (b) signals are phase shifted  $-45$  degrees and  $+45$  degrees, respectively. These signals are summed together and routed to the A6 signal processing and ADC module (SPAM) board.

Figure 5-6 Receiver Group

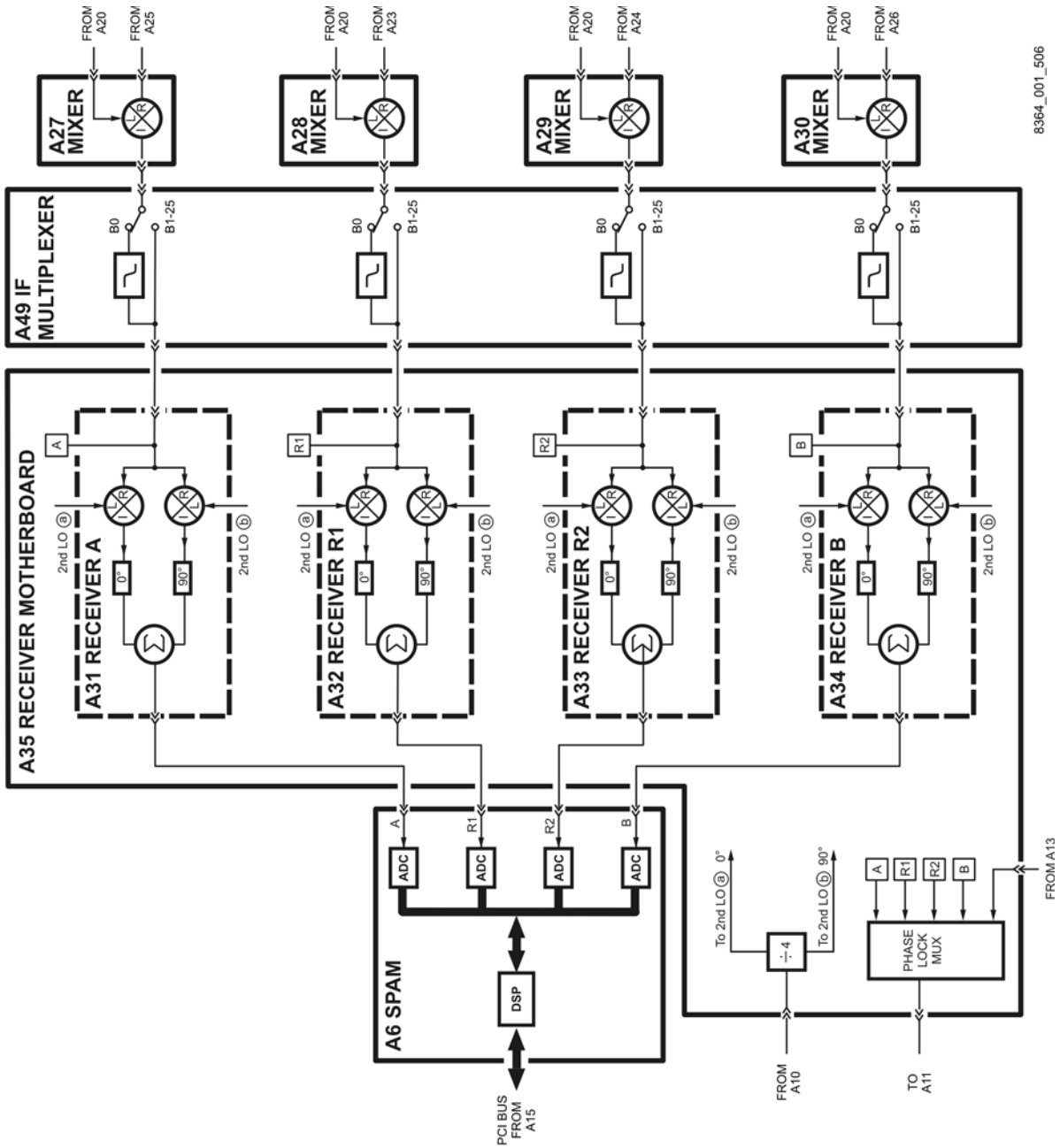

## A6 SPAM Board (Analog Description)

The A6 SPAM board contains digital and analog circuitry. For digital descriptions, refer to “[A6 SPAM Board \(Digital Description\)](#)” on page 5-31.

In this assembly, the 2nd IF signals from the A, B, R1, and R2 second converters go through a gain stage where signals less than  $-40$  dBm are amplified by 34 dB to ensure that they can be detected by the analog-to-digital converter (ADC).

All four signals are sampled simultaneously by the ADCs, where they are converted to digital form. The ADC conversions are triggered by timing signals from the digital signal processor (DSP) in response to commands from the central processing unit (CPU). The digitized data is processed into magnitude and phase data by the DSP and sent to the CPU random access memory (RAM) by way of the peripheral component interconnect (PCI) bus.

The processed and formatted data is finally routed to the display, and to the general-purpose interface bus (GPIB) for remote operation. Refer to “[Digital Processing and Digital Control Group Operation](#)” on page 5-28 for more information on signal processing.

## A35 Receiver Motherboard

The A35 receiver motherboard:

- supplies power and signal leveling control to the A31, A32, A33, and A34 receiver modules
- selects a phase lock signal and routes it to the A11 phase lock board
- receives the 2nd LO signal from the A10 frequency reference board

### Power and Signal Leveling Control

Power and signal leveling control signals are received from the A16 test set motherboard and routed to each of the receiver modules.

### Phase Lock Control

A portion of the 8.333 MHz 1st IF signal from each of the receiver modules is routed to a multiplexing circuit. For Option 080 (frequency offset mode), an additional signal is input to the multiplexer from the [A13 Frequency Offset Receiver Assembly \(Option 080\)](#). With control from the A15 CPU board, one of these five signals is selected for routing to the A11 phase lock board to complete the phase lock loop.

### 2nd LO Control

The 33.1667 MHz signal from the A10 frequency reference board is divided by four, and then divided into two paths, designated 2nd LO (a) and 2nd LO (b). The 2nd LO (b) signal is phase shifted  $+90^\circ$  relative to the 2nd LO (a) signal.

---

## Frequency Offset Group Operation (Options 080 and 081)

The frequency offset group provides the circuitry necessary to phase lock the analyzer while the source and receiver are tuned to different frequencies. [Figure 5-7 on page 5-25](#) is a simplified block diagram of the frequency offset functional group.

In this section the following assemblies are described:

- [A9 Fractional-N Synthesizer Board \(Option 080\)](#)
- [A13 Frequency Offset Receiver Assembly \(Option 080\)](#)
- [A45 and A46 Reference Transfer Switches \(Option 081\)](#)

### A9 Fractional-N Synthesizer Board (Option 080)

The A9 fractional-N synthesizer is identical to the A8 fractional-N synthesizer.

The A9 fractional-N synthesizer board uses the 5 MHz reference signal from the A10 frequency reference board to tune two VCO circuits: one that sweeps from 1500 to 3010 MHz and one that is set to a CW frequency of 2250 MHz. In bands 0–1, these two signals are heterodyned to produce the output frequencies for A8 listed in [Table 5-2 on page 5-8](#). In band 2, the output of the swept VCO is passed through a divide-by-2 circuit to produce the output frequencies for A8 listed in [Table 5-2](#). In all other bands, the swept VCO signal is sent directly to the synthesizer output.

At the output, an ALC circuit maintains the power level at  $-5 \text{ dBm} \pm 2 \text{ dB}$  for bands 0–1 or  $-1.5 \text{ dBm} \pm 2 \text{ dB}$  for bands 2–25. In all bands, the output is sent to the A13 frequency offset receiver assembly.

### A13 Frequency Offset Receiver Assembly (Option 080)

The A13 frequency offset receiver assembly consists of a frequency offset receiver board and a separate receiver module.

The output of the A9 fractional-N synthesizer board is directed to the receiver module where it is mixed with a signal from the A12 source assembly to produce a phase lock output signal.

This phase lock signal is sent to a multiplexer on the A35 receiver motherboard, the output of which is routed to the A11 phase lock board to complete the phase lock loop. Refer to [“Phase Lock Control” on page 5-23](#).

### A45 and A46 Reference Transfer Switches (Option 081)

The A45 and A46 reference transfer switches are used to direct the reference signal to either an external reference mixer or directly to the A28 channel R1 first converter (mixer). Refer to [“A27, A28, A29, and A30 Receiver First Converters \(Mixers\)” on page 5-21](#).

This allows an external reference mixer to be switched in or out of the measurement setup without the need to manually disconnect and reconnect cables.



**Figure 5-7 Frequency Offset Group**

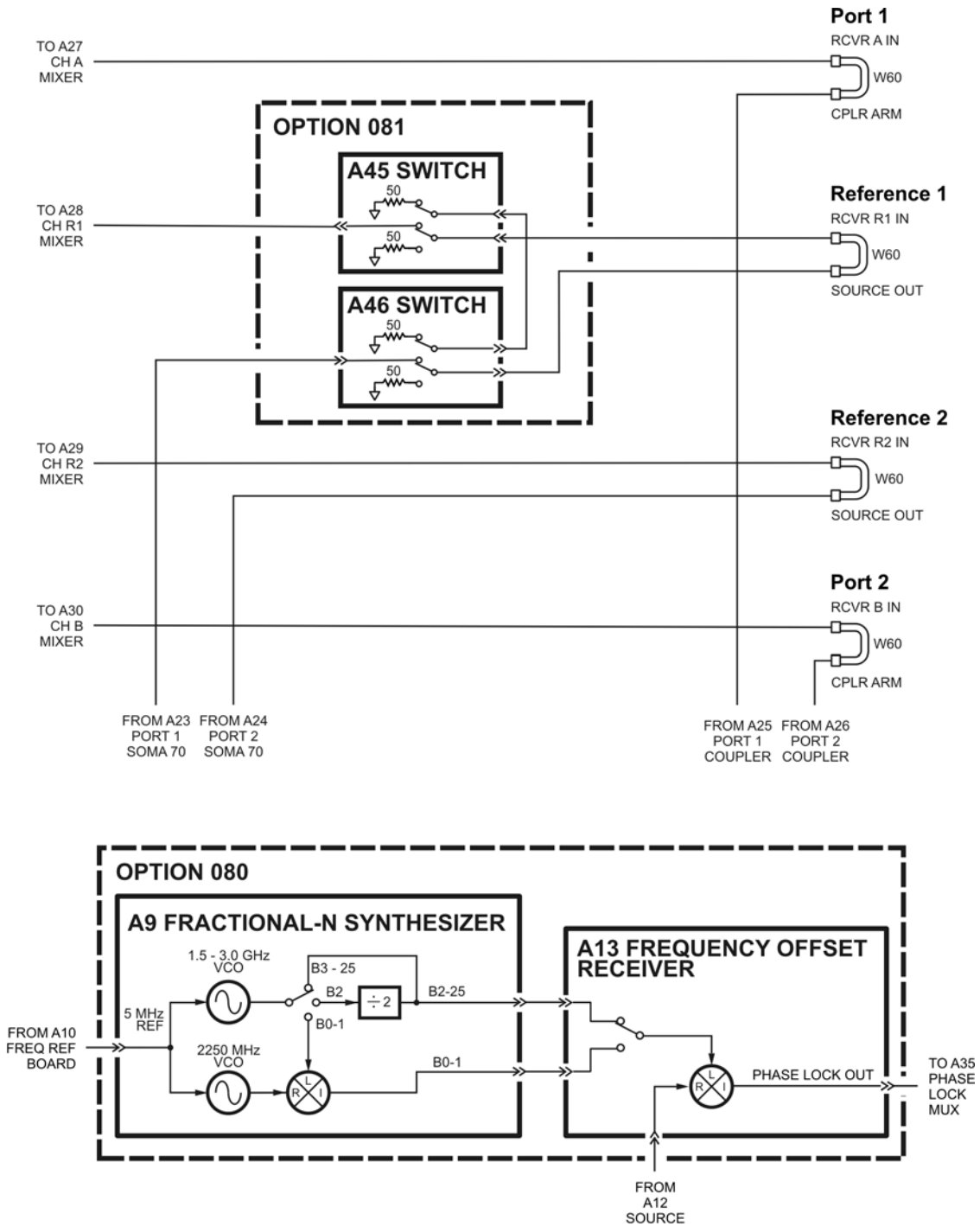

8364\_001\_507

---

## IF Access Group (Option H11)

The IF access group is additional hardware included in the PNA that allows for external connection to the internal IF path of the analyzer.

The following assemblies and components are included in the IF access group:

- [A47 RF Path Coupler](#)
- [A48 LO Path Coupler](#)
- [A49 IF Multiplexer Board](#)
- [Rear-Panel Connections](#)
  - TEST SET DRIVERS
  - PULSE IN
  - 8.33 MHz IF IN

### A47 RF Path Coupler

The A47 RF path coupler is located in the RF path of the PNA between the A12 source and either the A21 SOMA 50 (for E8363/4C) or the A22 switch (for E8362C). A portion of the RF signal is coupled off and delivered to the rear-panel TEST SET DRIVERS RF connector.

### A48 LO Path Coupler

The A48 LO path coupler is located in the LO path of the PNA between the A18 MA24 and the A19 splitter. A portion of the LO signal is coupled off and delivered to the rear-panel TEST SET DRIVERS LO connector.

### A49 IF Multiplexer Board

The A49 IF multiplexer board provides the circuitry to allow the external pulse and IF signals to be input.

### Rear-Panel Connections

**TEST SET DRIVERS:** A portion of the RF path signal and the LO path signal is coupled off and routed to the rear panel TEST SET DRIVERS RF and LO connectors. These connectors provide access to the RF and LO signals for use by an external test set.

**PULSE IN:** An RF pulse input connection is provided for each of the four receiver channels (A, R1, R2, and B) via four rear-panel connectors. These signals are routed to the A49 IF multiplexer board where they can be switched into the signal path of each of the four measurement channels.

**8.33 MHz IF IN:** An 8.33 MHz IF input connection is provided for each of the four receiver channels (A, R1, R2, and B) via four rear-panel connectors. These signals are routed to the A49 IF multiplexer board where they can be switched into the signal path of each of the four measurement channels.

**Figure 5-8 IF Access Group**

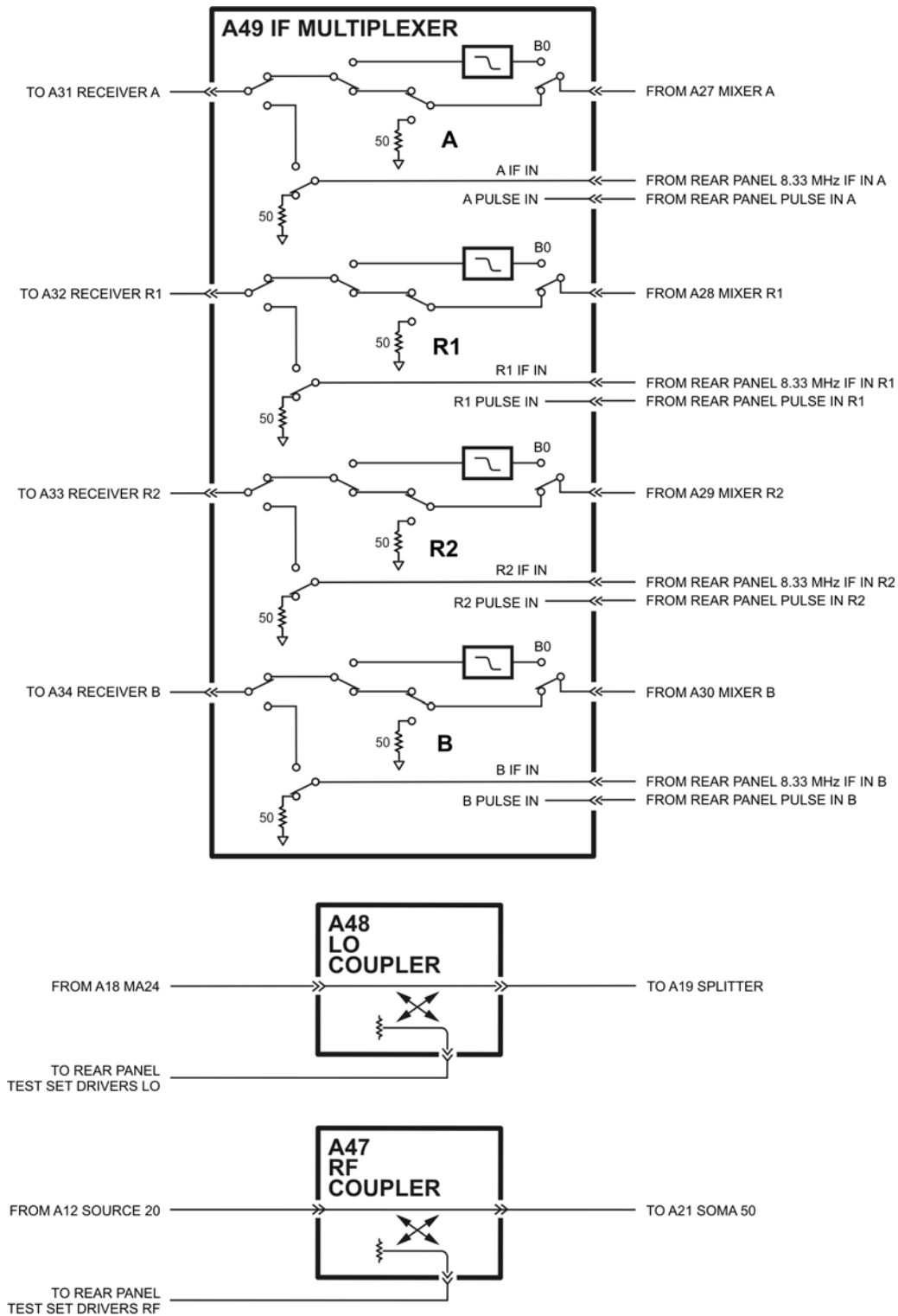

8361\_001\_509

---

## Digital Processing and Digital Control Group Operation

The digital processor and control group provides digital control for the entire analyzer. It provides:

- front panel operation,
- output to the display,
- math processing functions, and
- communications between the analyzer and an external controller or peripherals.

A block diagram of the digital control functional group is shown in [Figure 5-9 on page 5-29](#).

The digital control functional group consists of two subgroups:

- **Front Panel Subgroup**
  - A1 Keypad Assembly
  - A2 Display Assembly
  - A3 Front Panel Interface Board
  - A14 system motherboard
- **Data Acquisition and Processing Subgroup**
  - A6 SPAM Board (Digital Description)
  - A15 CPU Board
  - A41 Hard Disk Drive
  - USB Hub

Figure 5-9 Digital Processing and Digital Control Group

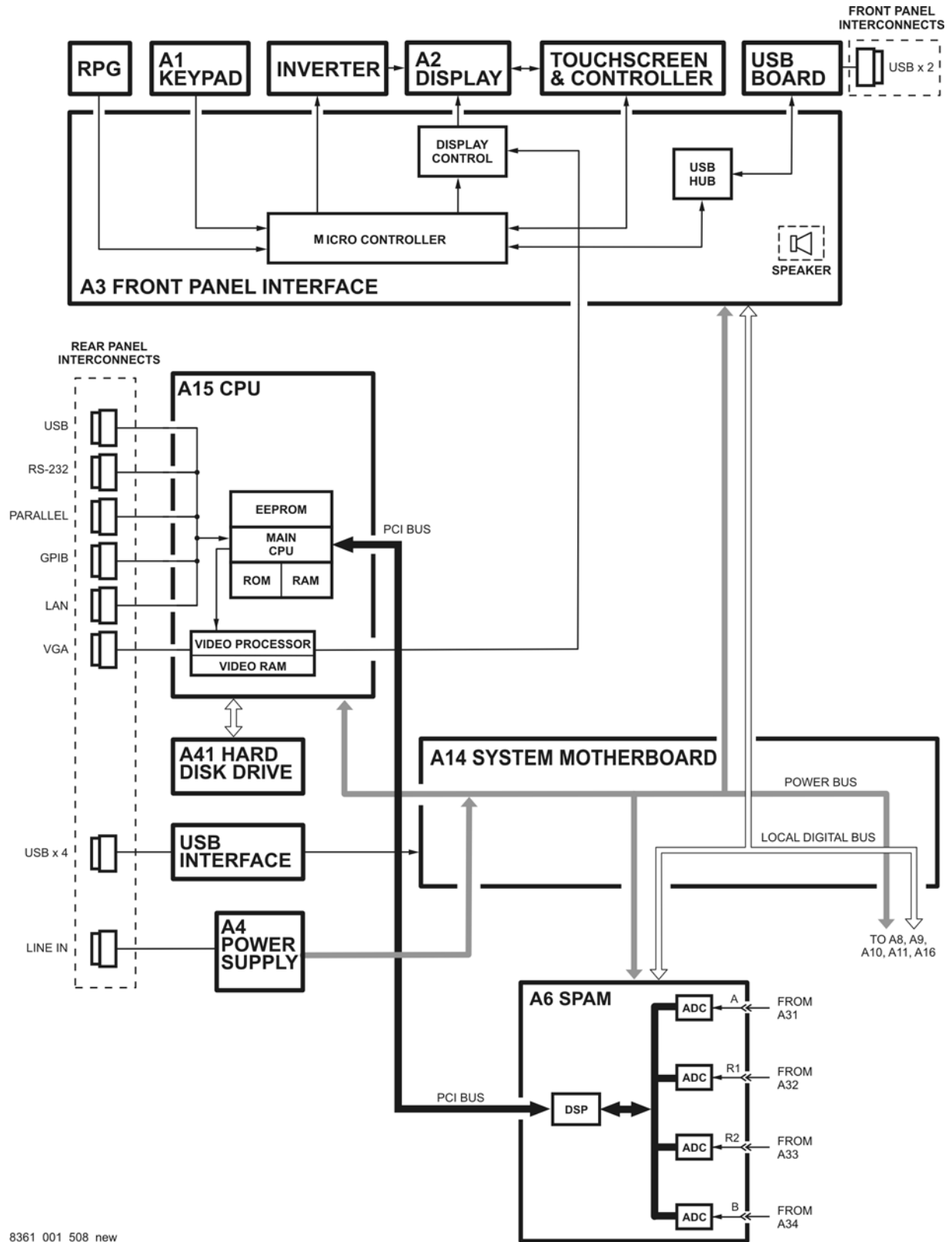

8361\_001\_508\_new

## Front Panel Subgroup

The front panel subgroup contains the following assemblies:

- [A1 Keypad Assembly](#)
- [A2 Display Assembly](#)
- [A3 Front Panel Interface Board](#)

### A1 Keypad Assembly

The A1 keypad assembly provides user interface to the analyzer. The front panel rotary pulse generator (RPG) knob is not electrically connected to the keypad, but rather provides user inputs directly to the front panel processor.

### A2 Display Assembly

The A2 display assembly contains an 8.4-inch LCD with associated drive circuitry and backlight inverter. Two cables between the A2 display assembly and the A3 front panel interface board provide all necessary power and data for normal operation. The two cables are:

1. A cable to the inverter that supplies buffered power.
2. A cable to the display circuitry that supplies decoded data from the video processor on the A15 CPU board and the necessary drive circuit power. The video data received from the A15 CPU board includes the following:

- digital TTL horizontal sync
- digital TTL vertical sync
- digital TTL red video
- digital TTL green video
- digital TTL blue video
- blanking
- data clock

### A3 Front Panel Interface Board

The A3 front panel interface board detects and decodes user inputs from the A1 keypad assembly and front panel knob, and transmits them to the A15 CPU board by way of the A14 system motherboard. It also decodes video data from the video processor on the A15 CPU board and supplies this to the A2 display assembly. Power from the power bus on the A14 system motherboard is buffered and routed to the A1 keypad assembly and the A2 display assembly. All data and power signals are routed through a single cable connector to the A14 system motherboard.

The A3 front panel interface board also includes the following items:

<b>USB</b>	Two universal serial bus (USB) jacks (industry standard 4-pin connectors) mounted on a separate USB connector board that connects directly to the A3 front panel interface board.
<b>Speaker</b>	A speaker that emits the audio signals received from the A15 CPU board.

## Data Acquisition and Processing Subgroup

The data acquisition and processing subgroup contain the following assemblies. See [Figure 5-9 on page 5-29](#).

- [A6 SPAM Board \(Digital Description\)](#)
- [A15 CPU Board](#) (including rear-panel interconnects)
- [A41 Hard Disk Drive](#)
- [USB Hub](#)

### A6 SPAM Board (Digital Description)

The A6 SPAM board contains digital and analog circuitry. For analog descriptions, refer to “[A6 SPAM Board \(Analog Description\)](#)” on [page 5-23](#).

The digital signal processor (DSP) receives digitized data from the digital circuitry of the A6 SPAM board. It computes discrete Fourier transforms to extract the complex phase and magnitude data from the 41.667 kHz IF signal. The resulting raw data is written into the main random access memory (RAM). The data taking sequence is triggered either externally from the rear panel or by firmware on the A15 CPU board.

### A15 CPU Board

The A15 CPU board contains the circuitry to control the operation of the analyzer. Some of the components include the central processing unit (CPU), memory (EEPROM, ROM, RAM), bus lines to other board assemblies, and connections to the rear panel. Some of the main components are described next:

- [CPU](#)
- [Main RAM](#)
- [Rear Panel Interconnects](#)

**CPU** The central processing unit (CPU) is a microprocessor that maintains digital control over the entire instrument through the instrument bus. The CPU receives external control information from the keypad, any USB device, LAN or GPIB, and performs processing and formatting operations on the raw data in the main RAM. It controls the DSP, the video processor, and the interconnect port interfaces. In addition, when the analyzer is in the system controller mode, the CPU controls peripheral devices through the peripheral port interfaces.

Front panel settings are stored in SRAM, with a battery providing at least five years of backup storage when external power is off.

**Main RAM** The main random access memory (RAM) is shared memory for the CPU and the DSP. It stores the raw data received from the DSP while additional calculations are performed on it by the CPU. The CPU reads the resulting formatted data from the main RAM, converts it to a user-definable display format, and writes this to the video processor for display.

**Rear Panel Interconnects** The rear panel includes the following interfaces:

<b>USB</b>	A universal serial bus (USB) jack (an industry standard 4-pin connector).
<b>GPIB</b>	A 24-pin, female, type D-24 connector that meets IEEE-488 standards.
<b>Serial</b>	A 9-pin, male, RS-232 compatible, D-sub connector.

<b>Parallel</b>	A 36-pin, mini-D, 1284-C connector that provides connection to printers or any other parallel port peripheral.
<b>LAN</b>	A standard 8-pin, 10/100BaseT, Ethernet connection. It auto selects between the two data rates.
<b>Display (VGA)</b>	A 15-pin, female, D-sub connector that provides a video output of the analyzer display that can be viewed on an external VGA monitor.

### **A41 Hard Disk Drive**

The hard disk drive assembly (HDDA) is an integrated development environment (IDE) data storage device which is connected directly to the A15 CPU board. The full operating system and firmware for the network analyzer is stored on the A41 hard disk drive.

### **USB Hub**

The rear-panel mounted, internal USB hub provides four additional USB ports for connection of external USB compatible devices.



---

## Power Supply Group Operation

The A4 power supply assembly is a switching power supply operating at 103 kHz switching frequency. The input power ranges for the power supply are 90 to 132 Vac or 195 to 250 Vac. The power supply automatically senses the input voltage and switches between these two ranges.

The dc output voltages are:

- +5.2 V
- -5.2 V
- +9 V
- +15 V
- +15 V standby (always on)
- -15 V
- +22 V
- VCC (5.2 V for the A15 CPU board)
- VDL (3.3 V to the A15 CPU board)

The +15 V standby line remains on continuously whenever the power supply is plugged in. This line is used to provide power to front panel LEDs and CPU components when the analyzer is turned off.

An additional +32 V supply line is generated on the A14 system motherboard from the +22 V supply line.

---

**NOTE** If the power supply senses an over-voltage or over-current condition on any of the supply lines, the power supply will cycle on and off at a low voltage level (burp mode).

---



---

## **6 Replaceable Parts**

## Information in This Chapter

This chapter:

- identifies the replaceable parts for the Agilent PNA series microwave network analyzers.
- includes several tables and illustrations to assist you in identifying the correct part for your analyzer.
- contains ordering information for new assemblies and rebuilt-exchange assemblies.

### How to Use the Replaceable Parts Listings in This Chapter

There are multiple replaceable parts listings in this chapter for top and bottom assemblies and top and bottom cables. When searching for the part number for a specific item, it is necessary to use both the “No Options” listing and the “Options” listing that applies to your analyzer.

For example: If your analyzer has option UNL installed, and you need the part number for a replaceable assembly on the bottom of the analyzer, you would refer to both [“Bottom Assemblies, No Options” on page 6-22](#) and [“Bottom Assemblies, Option UNL” on page 6-26](#). If the same part is listed in both lists, part numbers listed in the “Options” listing supersede those in the “No Options” listing.

### Chapter Six at-a-Glance

Section Title	Summary of Content	Start Page
<a href="#">Ordering Information</a>	How to order a replaceable part from Agilent Technologies.	<a href="#">Page 6-3</a>
<a href="#">Assembly Replacement Sequence</a>	The correct sequence for replacing a defective assembly.	<a href="#">Page 6-4</a>
<a href="#">Rebuilt-Exchange Assemblies</a>	The definition of a rebuilt-exchange assembly. The procedure for replacing and returning a defective assembly to Agilent Technologies. <sup>77</sup>	<a href="#">Page 6-5</a>
<a href="#">Replaceable Parts Listings</a>	This section lists the assemblies by their reference number and illustrates the location of the replaceable parts in the analyzer, including: <ul style="list-style-type: none"> <li>• Assemblies (front panel, top, and bottom)</li> <li>• Cables (top and bottom)</li> <li>• Options (parts included with options)</li> <li>• Hardware (internal, hard disk drive, rear panel, and external)</li> </ul>	<a href="#">Page 6-6</a>

---

## Ordering Information

To order a part listed in the replaceable parts lists:

- include the part number
- indicate the quantity required
- Contact Agilent Technologies for instructions on where to send the order. Refer to [“Contacting Agilent” on page 2-12](#).

To order a part that is not listed in the replaceable parts lists:

- include the instrument model number and complete instrument serial number
- include the description and function of the part
- indicate the quantity required
- Contact Agilent Technologies for instructions on where to send the order. Refer to [“Contacting Agilent” on page 2-12](#).

---

## Assembly Replacement Sequence

The following steps show the sequence that you should follow to replace an assembly in the network analyzer.

- Step 1.** Identify the faulty group. Begin with [Chapter 4, "Troubleshooting."](#) Follow up with the appropriate troubleshooting chapter that identifies the faulty assembly.
- Step 2.** Order a replacement assembly. Refer to this chapter.
- Step 3.** Replace the faulty assembly and determine what adjustments are necessary. Refer to [Chapter 7, "Repair and Replacement Procedures."](#)
- Step 4.** Perform the necessary adjustments. Refer to [Chapter 3, "Tests and Adjustments."](#)
- Step 5.** Perform the necessary performance tests. Refer to [Chapter 3, "Tests and Adjustments."](#)

## Rebuilt-Exchange Assemblies

Under the rebuilt-exchange assembly program:

- Certain factory-repaired and tested assemblies are available on a trade-in basis.
- Exchange assemblies are offered for lower cost than a new assembly, but meet all factory specifications required of a new assembly.
- The defective assembly must be returned for credit under the terms of the rebuilt-exchange assembly program.
- Spare assembly stock desired should be ordered using the new assembly part number.

**Figure 6-1 Module Exchange Procedure**

The module exchange program described here is a fast, efficient, economical method of keeping your instrument in service.

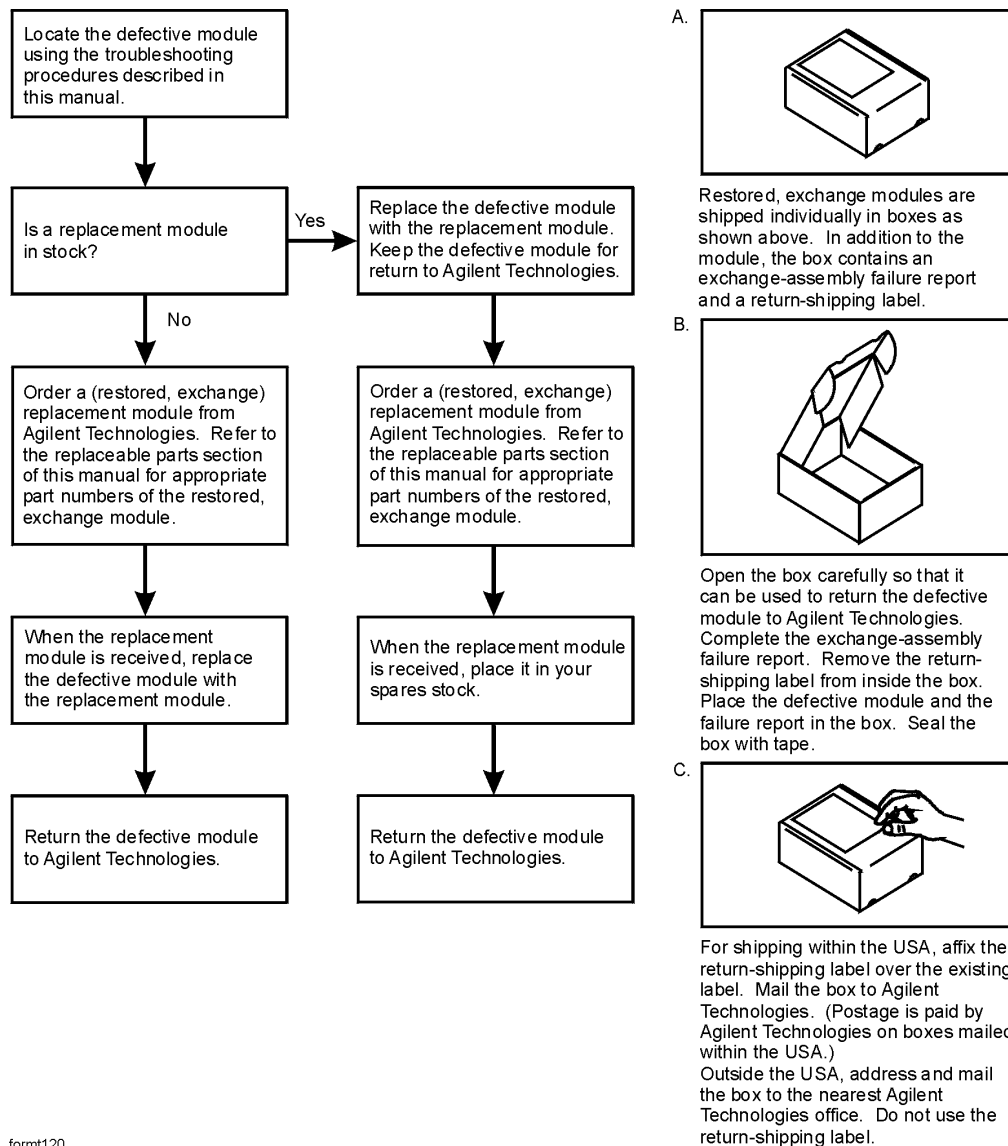

formt120

## Replaceable Parts Listings

This section contains the replacement part numbers and their descriptions for your Agilent PNA series microwave network analyzer. You can find the locations of replaceable parts in this section:

- listed by reference designator in [Table 6-1](#), or
- listed by the type of part in [Table 6-2](#).

**Table 6-1 Location by Reference Designator**

Reference Designator	Description	Location <sup>a</sup>
A1	Keypad assembly	"Front Panel Assembly, Back Side, All Options" on page 6-12
A2	Display assembly	
A3	Front panel interface board	
A4	Power supply assembly	"Top Assemblies, All Options Except 080" on page 6-14
A6	Signal processing ADC module (SPAM) board	
A8	Fractional-N synthesizer board	
A9	Fractional-N synthesizer board (Option 080)	"Top Assemblies, All Options Including 080" on page 6-18
A10	Frequency reference board	"Top Assemblies, All Options Except 080" on page 6-14
A11	Phase lock board	
A12	Source 20	
A13	Frequency offset receiver assembly (Option 080)	"Top Assemblies, All Options Including 080" on page 6-18
A14	System motherboard	"Top Assemblies, All Options Except 080" on page 6-14
A15	CPU board	
A16	Test set motherboard	"Bottom Assemblies, No Options" on page 6-22
A17	Local oscillator multiplier/amplifier 10 (LOMA 10)	
A18	Multiplier/amplifier (MA 20)	
A19	Splitter	
A20	Local oscillator distribution assembly (LODA)	
A21	Source multiplier/amplifier 50 (SOMA 50) (E8363C, E8364C only)	
A22	Switch splitter	
None	Channel R1 30-dB attenuator (E8362C only)	
None	Channel R2 30-dB attenuator (E8362C only)	



**Table 6-1 Location by Reference Designator (Continued)**

<b>Reference Designator</b>	<b>Description</b>	<b>Location<sup>a</sup></b>	
A23	Channel R1 detector (E8363C, E8364C only)	"Bottom Assemblies, No Options" on page 6-22	
A24	Channel R2 detector (E8363C, E8364C only)		
A25	Test port 1 coupler		
A26	Test port 2 coupler		
A27	Channel A first converter (mixer)		
A28	Channel R1 first converter (mixer)		
A29	Channel R2 first converter (mixer)		
A30	Channel B first converter (mixer)		
A31	Channel A receiver module		
A32	Channel R1 receiver module		
A33	Channel R2 receiver module		
A34	Channel B receiver module		
A35	Receiver motherboard		
A36	Port 1 60-dB step attenuator (Option UNL)		"Bottom Assemblies, Option UNL" on page 6-26
A37	Port 2 60-dB step attenuator (Option UNL)		
A38	Port 1 bias tee (Option UNL)		
A39	Port 2 bias tee (Option UNL)		
A40	Not used.		
A41	Hard disk drive assembly	"Hard Disk Drive Assembly, All Options" on page 6-80	
A43	35-dB step attenuator (Option 016)	"Bottom Assemblies, Options UNL/016" on page 6-38	
A44	35-dB step attenuator (Option 016)		
A45	50 GHz switch (Option 081)	"Bottom Assemblies, Options 014/080/081" on page 6-46	
A46	50 GHz switch (Option 081)		
A47	RF path coupler (Option H11)	"Bottom Assemblies, Options UNL/014/080/081/H11" on page 6-54	
A48	LO path coupler (Option H11)		
A49	IF multiplexer board	"Bottom Assemblies, No Options" on page 6-22	

a. Refer to "How to Use the Replaceable Parts Listings in This Chapter" on page 6-2.

**Table 6-2 Part Number Location by Type of Part**

Type of Part	Location <sup>a</sup>
<b>Assemblies</b>	<ul style="list-style-type: none"> <li>• “Front Panel Assembly, Back Side, All Options” on page 6-12</li> <li>• “Top Assemblies, All Options Except 080” on page 6-14</li> <li>• “Top Assemblies, All Options Including 080” on page 6-18</li> <li>• “Bottom Assemblies, No Options” on page 6-22</li> <li>• “Bottom Assemblies, Option UNL” on page 6-26</li> <li>• “Bottom Assemblies, Option 014 and Options 014/080” on page 6-30</li> <li>• “Bottom Assemblies, Options UNL/014 and UNL/014/080” on page 6-34</li> <li>• “Bottom Assemblies, Options UNL/016” on page 6-38</li> <li>• “Bottom Assemblies, Options UNL/014/016 and UNL/014/016/080” on page 6-42</li> <li>• “Bottom Assemblies, Options 014/080/081” on page 6-46</li> <li>• “Bottom Assemblies, Options UNL/014/080/081” on page 6-50</li> <li>• “Bottom Assemblies, Options UNL/014/016/080/081” on page 6-58</li> <li>• “Bottom Assemblies, Options UNL/014/080/081/H11” on page 6-54</li> <li>• “Rear Panel Assembly, All Options” on page 6-78</li> <li>• “Internal Hardware and Parts, All Options” on page 6-74</li> <li>• “Hard Disk Drive Assembly, All Options” on page 6-80</li> </ul>
<b>Cables</b>	<ul style="list-style-type: none"> <li>• “Top Cables—All, All Options Except 080” on page 6-16</li> <li>• “Top Cables—All, All Options Including 080” on page 6-20</li> <li>• “Bottom Semi-Rigid Cables, No Options” on page 6-24</li> <li>• “Bottom Semi-Rigid Cables, Option UNL” on page 6-28</li> <li>• “Bottom Semi-Rigid Cables, Options 014 and 014/080” on page 6-32</li> <li>• “Bottom Semi-Rigid Cables, Options UNL/014 and UNL/014/080” on page 6-36</li> <li>• “Bottom Semi-Rigid Cables, Options UNL/016” on page 6-40</li> <li>• “Bottom Semi-Rigid Cables, Options UNL/014/016 and UNL/014/016/080” on page 6-44</li> <li>• “Bottom Semi-Rigid Cables, Options 014/080/081” on page 6-48</li> <li>• “Bottom Semi-Rigid Cables, Options UNL/014/080/081” on page 6-52</li> <li>• “Bottom Semi-Rigid Cables, Options UNL/014/016/080/081” on page 6-60</li> <li>• “Bottom Semi-Rigid Cables, Options UNL/014/080/081/H11” on page 6-56</li> <li>• “Bottom Flexible Cables, All Options” on page 6-66</li> <li>• “Bottom Ribbon Cables and Wrapped-Wire, All Options” on page 6-68</li> </ul>

**Table 6-2 Part Number Location by Type of Part (Continued)**

Type of Part	Location <sup>a</sup>
<b>Hardware</b>	<ul style="list-style-type: none"> <li>• “Top Hardware, All Options” on page 6-70</li> <li>• “Bottom Hardware, All Options” on page 6-72</li> <li>• “Rear Panel Assembly, All Options” on page 6-78</li> <li>• “Internal Hardware and Parts, All Options” on page 6-74</li> <li>• “External Hardware and Parts, All Options” on page 6-76</li> <li>• “Hard Disk Drive Assembly, All Options” on page 6-80</li> </ul>
<b>Miscellaneous</b>	<ul style="list-style-type: none"> <li>• Front Panel Assembly, Front Side, All Options on page 6-10</li> <li>• Service Tools on page 6-84</li> <li>• Fuses on page 6-86</li> <li>• Battery on page 6-84</li> <li>• Documentation on page 6-84</li> <li>• Protective Caps for Connectors on page 6-84</li> <li>• GPIB Cables/GPIB Adapter on page 6-84</li> <li>• ESD Supplies on page 6-86</li> <li>• E8362C Upgrade Kits on page 6-85</li> <li>• E8363C, E8364C Upgrade Kits on page 6-85</li> <li>• Touch-up Paint on page 6-86</li> <li>• USB Accessories on page 6-86</li> <li>• Rack Mount Kits and Handle Kits on page 6-86</li> </ul>

a. Refer to “How to Use the Replaceable Parts Listings in This Chapter” on page 6-2.

### Front Panel Assembly, Front Side, All Options

Reference Designator	Part Number	Qty	Description
① <sup>a</sup>	N5230-20225 Was N5230-20125	1	Front frame
②	N5230-80028 Was N5230-80018 <sup>b</sup>	1	Keypad overlay
③ <sup>c</sup>	5041-9183	2	With handles—front handle side trim
	5041-9174	2	Without handles—trim strip, filler
④	N5230-00016	1	Lower front dress panel
⑤	E8364-80002	1	Front panel overlay; no options, Option UNL, or Option UNL/016
	E8364-80003		Front panel overlay; Option 014, 014/080, or 014/080/081
	E8364-80011		Front panel overlay; Option UNL/014, UNL/014/080/081, or UNL/014/080/081/H11
	E8364-80024		Front panel overlay; Option UNL/014/016, UNL/014/016/080, UNL/014/016/080/081, or UNL/014/016/080/081/H11
⑥	0515-4791	10	Machine screw, M3.0 x 4 flat head
⑦	W1312-40017	1	Front knob
⑧	E8362-80004	1	Nameplate, E8362C 10 MHz to 20 GHz
	E8363-80003		Nameplate, E8363C 10 MHz to 40 GHz
	E8364-80046		Nameplate, E8364C 10 MHz to 50 GHz

- a. When ordering a replacement front frame assembly, you must also order items ②, ⑤, and ⑧.
- b. Use keyboard overlay part number N5230-80018 with the following models and serial numbers:  
 \* E8362C: MY48120116 and below; SG48120102 and below.  
 \* E8362CH85: MY48150106 and below; SG48150101 and below.  
 \* E8363C: MY48130162 and below; SG48130102 and below.  
 \* E8363CH85: MY48150101.  
 \* E8364C: MY48140153.  
 \* E8364CH85: MY48150101.
- c. For part numbers of rack mount kits and handle kits, refer to ["Rack Mount Kits and Handle Kits"](#) on page 6-86.

Figure 6-2 Front Panel Assembly, Front Side, All Options

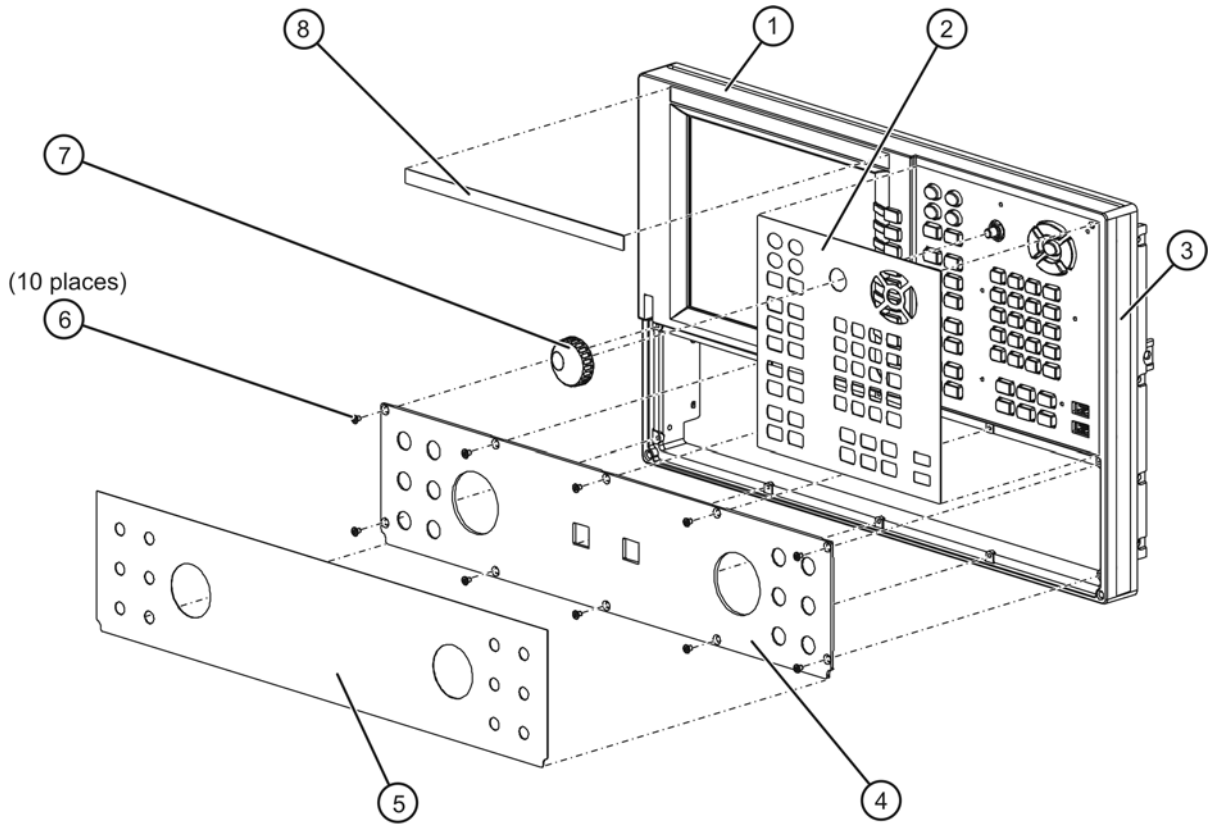

2pfp\_front\_exploded

### Front Panel Assembly, Back Side, All Options

Reference Designator	Part Number	Qty	Description
A1	N5230-40002	1	Keypad assembly
A2	N5230-60045	1	Display assembly (Includes the following parts; not separately orderable.) ❶—LCD display, 8.4-inch, 1024 x 768 pixels ❷—Machine screw, M2.5 x 8 pan head ❸—Display ribbon cable ❹—Cable clamp (for display ribbon cable) ❺—Cable clamp (for inverter cable) ❻—Display bracket ❼—Cable clamp (for display cables and touchscreen cable)
A3	N5230-60132	1	Front panel interface board
❶	N5230-20225 Was N5230-20125	1	Front frame
❷	8160-0660	1	RFI gasket
❸	N5230-40003	1	Touch screen rubber boot
❹	E6601-61028	1	Inverter cable
❺	2090-0959	1	Touch screen display, 8.4-inch, 4096 x 4096 pixels
❻	0515-0430	13	Machine screw, M3.0 x 6 pan head
❼	0950-4482	1	Inverter board
❽	0515-0372	8	Machine screw, M3.0 x 8 pan head
❾	N5230-00017 Was N5230-00013	1	Inverter board shield
❿	0515-1974	2	Machine screw, M2.5 x 4 pan head
⓫	0960-2796	1	Touch screen controller board
⓬	N5230-61002	1	Touch screen controller cable
⓭	N5230-60131	1	USB connector board
⓮	8160-1731	1	EMI gasket, D-shape, urethane, 4 mm W x 154 mm L
⓯	0400-0996	2	Grommet, oval, neoprene

**Figure 6-3 Front Panel Assembly, Back Side, All Options**

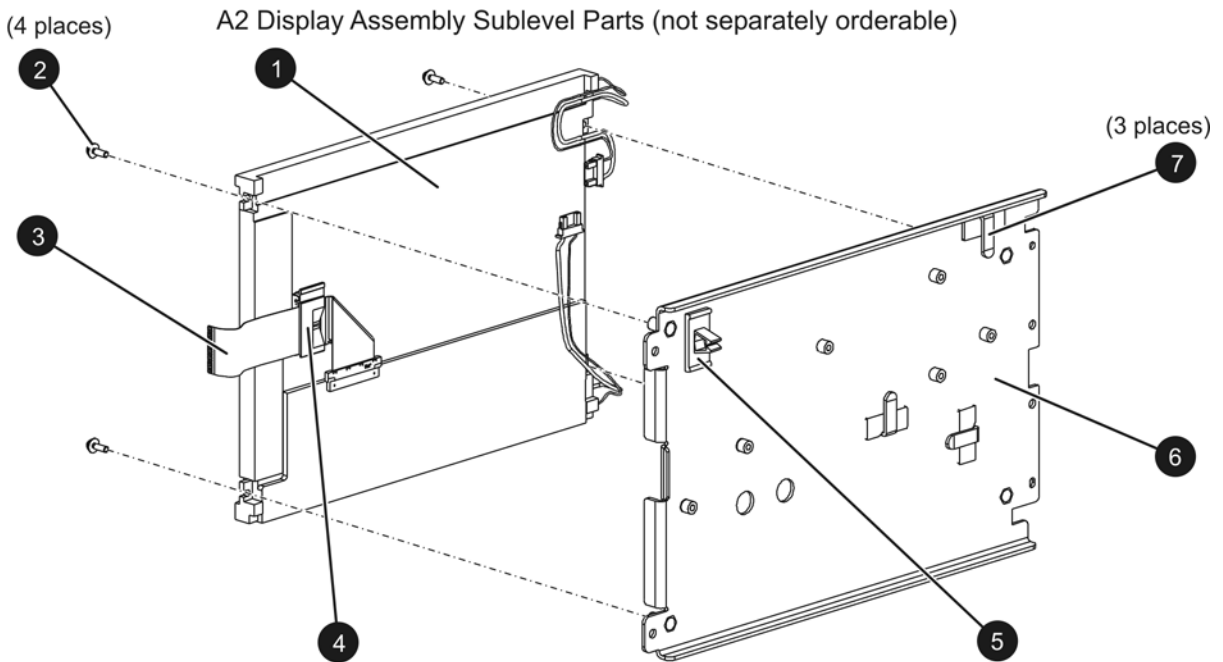
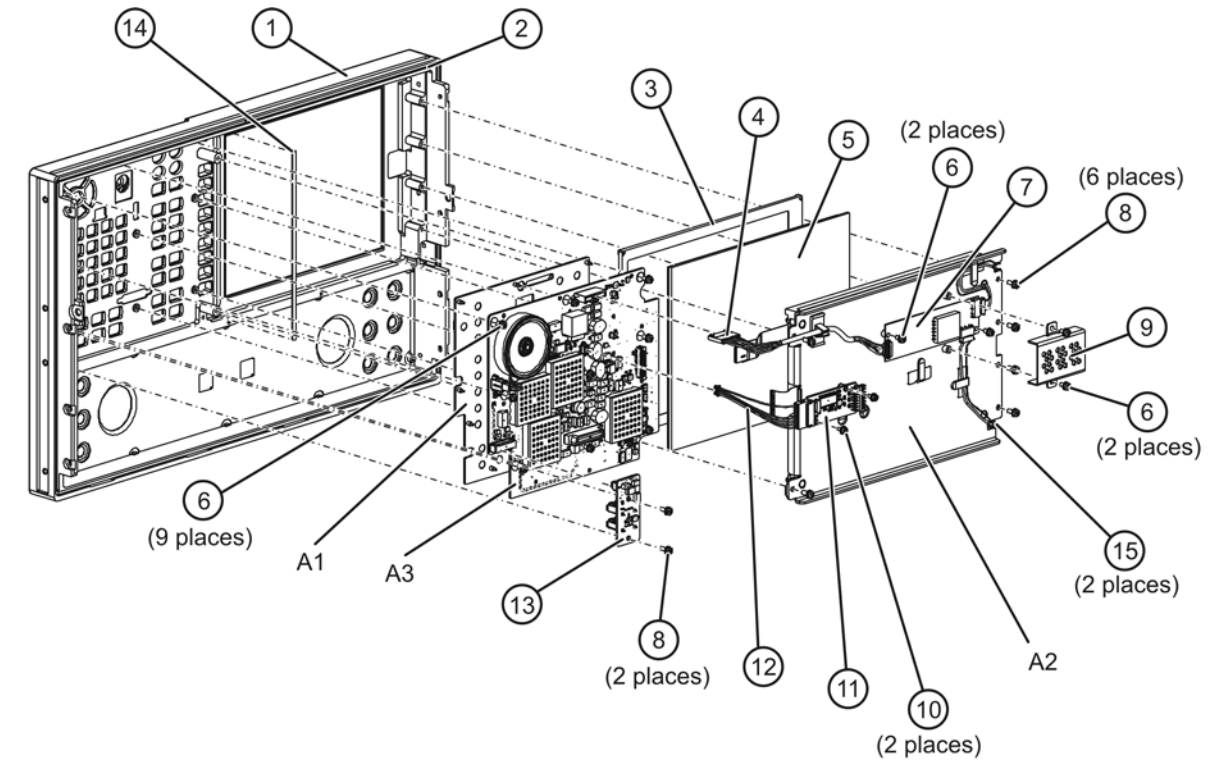

2pfp\_rear\_exploded

**Top Assemblies, All Options Except 080**

Ref. Desig.	Part Number <sup>a</sup>	Qty	Description
A4	0950-4599	1	Power supply assembly
A6	E8356-60006	1	Signal processing ADC module (SPAM) board
A8	E8364-60099	1	Fractional-N synthesizer board
A10	E8364-60136	1	Frequency reference board
A11	E8364-60137	1	Phase lock board
A12	E8362-60002 <i>E8362-69002</i>	1	Source 20
A14	E8364-60100	1	System motherboard
A15	E8364-60026	1	1.1 GHz CPU Replacement Kit
B1	Fans		Refer to <a href="#">“Internal Hardware and Parts, All Options”</a> on page 6-74.
①	USB hub board		Refer to <a href="#">“Top Hardware, All Options”</a> on page 6-70

a. Part numbers in *italic* typeface are for rebuilt exchange assemblies. Refer to [“Rebuilt-Exchange Assemblies”](#) on page 6-5.



Figure 6-4 Top Assemblies, All Options Except 080

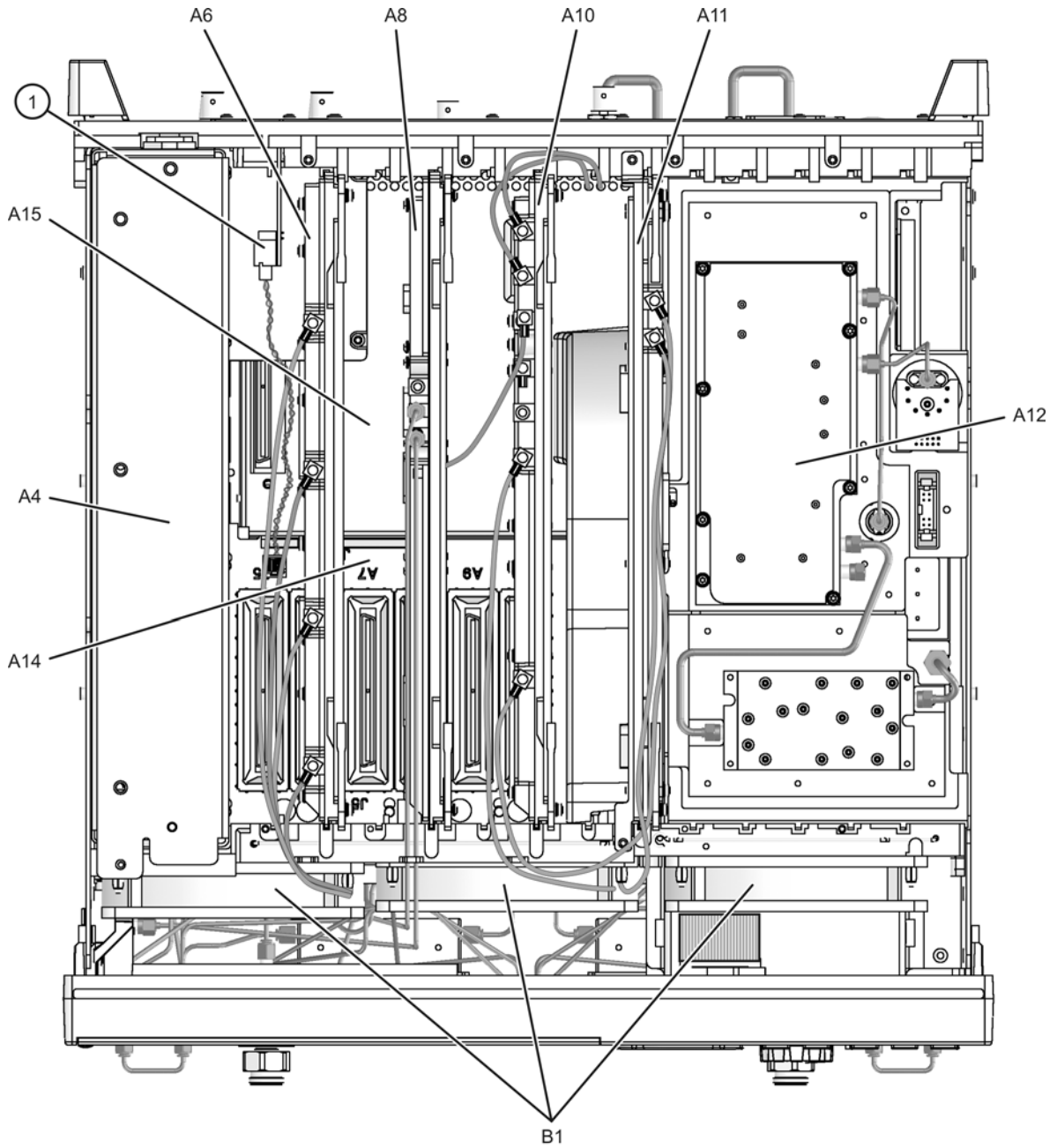

st521b

**Top Cables—All, All Options Except 080**

Ref. Desig.	Type <sup>a</sup>	Part Number	Qty	Description
W19	SR	E8364-20027	1	A8 fractional-N synthesizer board J106 to A17 LOMA 10 J2
W20	SR	E8364-20057	1	A8 fractional-N synthesizer board J101 to A17 LOMA 10 J3
W25	F	E8364-60126	1	A6 SPAM board J3 to A31 receiver A J400
W26	F	E8364-60127	1	A6 SPAM board J4 to A32 receiver R1 J400
W27	F	E8364-60128	1	A6 SPAM board J5 to A33 receiver R2 J400
W28	F	E8364-60129	1	A6 SPAM board J6 to A34 receiver B J400
W29	F	E8364-60124	1	A10 frequency reference board J4 to A35 receiver motherboard J2
W30	F	E8364-60125	1	A11 phase lock board J6 to A35 receiver motherboard J50
W31	F	E8356-60052	1	A10 frequency reference board J10 to A8 fractional-N synthesizer board J105
W32	F	E8356-60043	1	A10 frequency reference board J5 to A11 phase lock board J5
W33	F	8120-5055	1	A10 frequency reference board J2 to rear-panel 10 MHz REF. IN
W34			1	A10 frequency reference board J3 to rear-panel 10 MHz REF. OUT
①	40R	8121-0116	1	A3 front panel interface board to A14 system motherboard
②	6W	8121-0932	1	USB hub to A14 system motherboard

a. SR = semirigid coaxial cable; F = flexible coaxial cable; nR = n wires in a ribbon (flat) cable

Figure 6-5 Top Cables—All, All Options Except 080

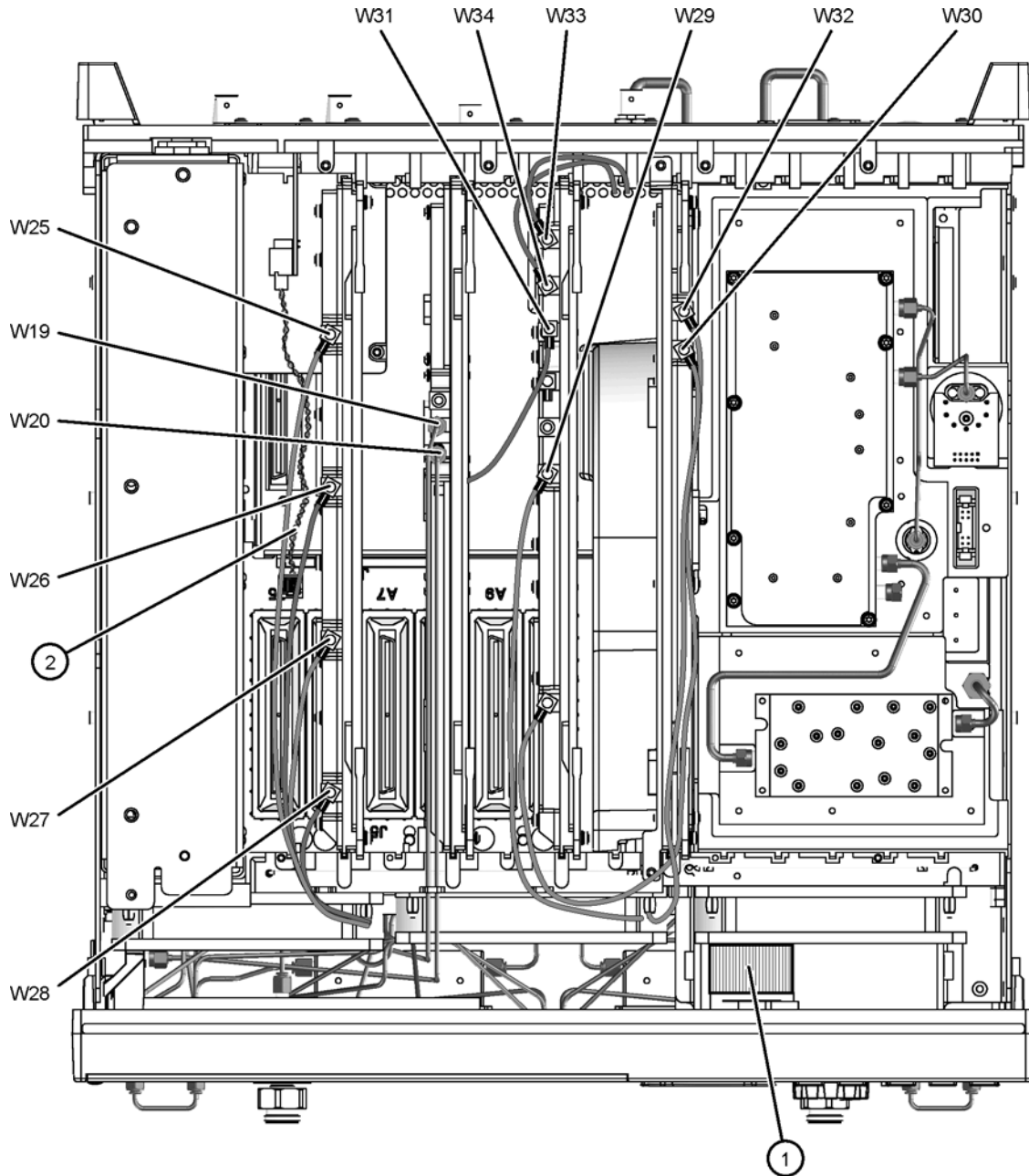

st526b

### Top Assemblies, All Options Including 080

Ref. Desig;	Part Number <sup>a</sup>	Qty	Description
A4	0950-4599	1	Power supply assembly
A6	E8356-60006	1	Signal processing ADC module (SPAM) board
A8	E8364-60099	1	Fractional-N synthesizer board
A9	E8364-60099	1	Fractional-N synthesizer board
A10	E8364-60136	1	Frequency reference board
A11	E8364-60137	1	Phase lock board
A12	E8362-60002 <i>E8362-69002</i>	1	Source 20
A13 (Option 080 only)	E8364-60097	1	Frequency offset receiver board
	E8356-60018	1	Frequency offset receiver module
	N3381-20032	1	Gasket
	E8364-20142	1	RF cable, receiver module to receiver board
	0515-1349	3	Machine screw, for attaching receiver module to receiver board
A14	E8364-60100	1	System motherboard
A15	E8364-60026	1	1.1 GHz CPU Replacement Kit
B1	Fans		Refer to <a href="#">“Internal Hardware and Parts, All Options”</a> on page 6-74.
①	USB hub board		Refer to <a href="#">“Top Hardware, All Options”</a> on page 6-70

a. Part numbers in *italic* typeface are for rebuilt exchange assemblies. Refer to [“Rebuilt-Exchange Assemblies”](#) on page 6-5.

Figure 6-6 Top Assemblies, All Options Including 080

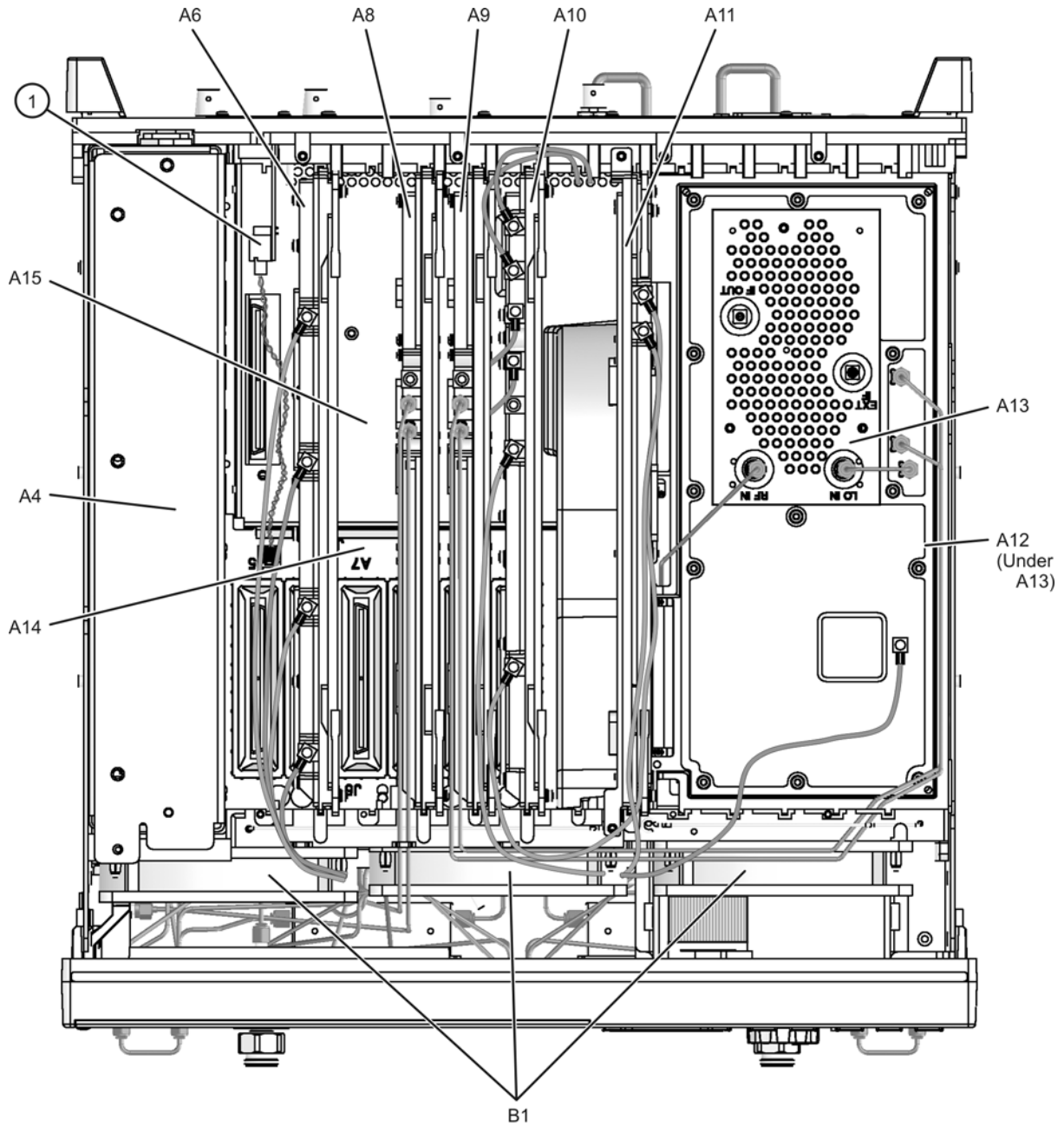

st566b

**Top Cables—All, All Options Including 080**

Ref. Desig.	Type <sup>a</sup>	Part Number	Qty	Description
W19	SR	E8364-20027	1	A8 fractional-N synthesizer board J106 to A17 LOMA 10 J2
W20	SR	E8364-20057	1	A8 fractional-N synthesizer board J101 to A17 LOMA 10 J3
W25	F	E8364-60126	1	A6 SPAM board J3 to A31 receiver A J400
W26	F	E8364-60127	1	A6 SPAM board J4 to A32 receiver R1 J400
W27	F	E8364-60128	1	A6 SPAM board J5 to A33 receiver R2 J400
W28	F	E8364-60129	1	A6 SPAM board J6 to A34 receiver B J400
W29	F	E8364-60124	1	A10 frequency reference board J4 to A35 receiver motherboard J2
W30	F	E8364-60125	1	A11 phase lock board J6 to A35 receiver motherboard J50
W31	F	E8356-60052	1	A10 frequency reference board J10 to A8 fractional-N synthesizer board J105
W32	F	E8356-60043	1	A10 frequency reference board J5 to A11 phase lock board J5
W33	F	8120-5055	1	A10 frequency reference board J2 to rear-panel 10 MHz REF. IN
W34			1	A10 frequency reference board J3 to rear-panel 10 MHz REF. OUT
W91	SR	E8364-20140	1	A9 fractional-N synthesizer board J106 to A13 frequency offset receiver assembly J4
W92	SR	E8364-20141	1	A9 fractional-N synthesizer board J101 to A13 frequency offset receiver assembly J2
W93	SR	E8364-20143	1	A13 frequency offset receiver assembly RF IN to A12 source 20
W115	F	E8364-60018	1	A10 frequency reference board J11 to A9 fractional-N synthesizer board J105
W116	F	E8364-60017	1	A13 frequency offset receiver assembly J6 to A35 receiver motherboard J502
①	40R	8121-0116	1	A3 front panel interface board to A14 system motherboard
②	SR	E8364-20142	1	A13 frequency offset receiver assembly J3 to receiver module LO IN (included with A13)
③	6W	8121-0932	1	USB hub to A14 system motherboard

a. SR = semirigid coaxial cable; F = flexible coaxial cable; nR = n wires in a ribbon (flat) cable

Figure 6-7 Top Cables—All, All Options Including 080

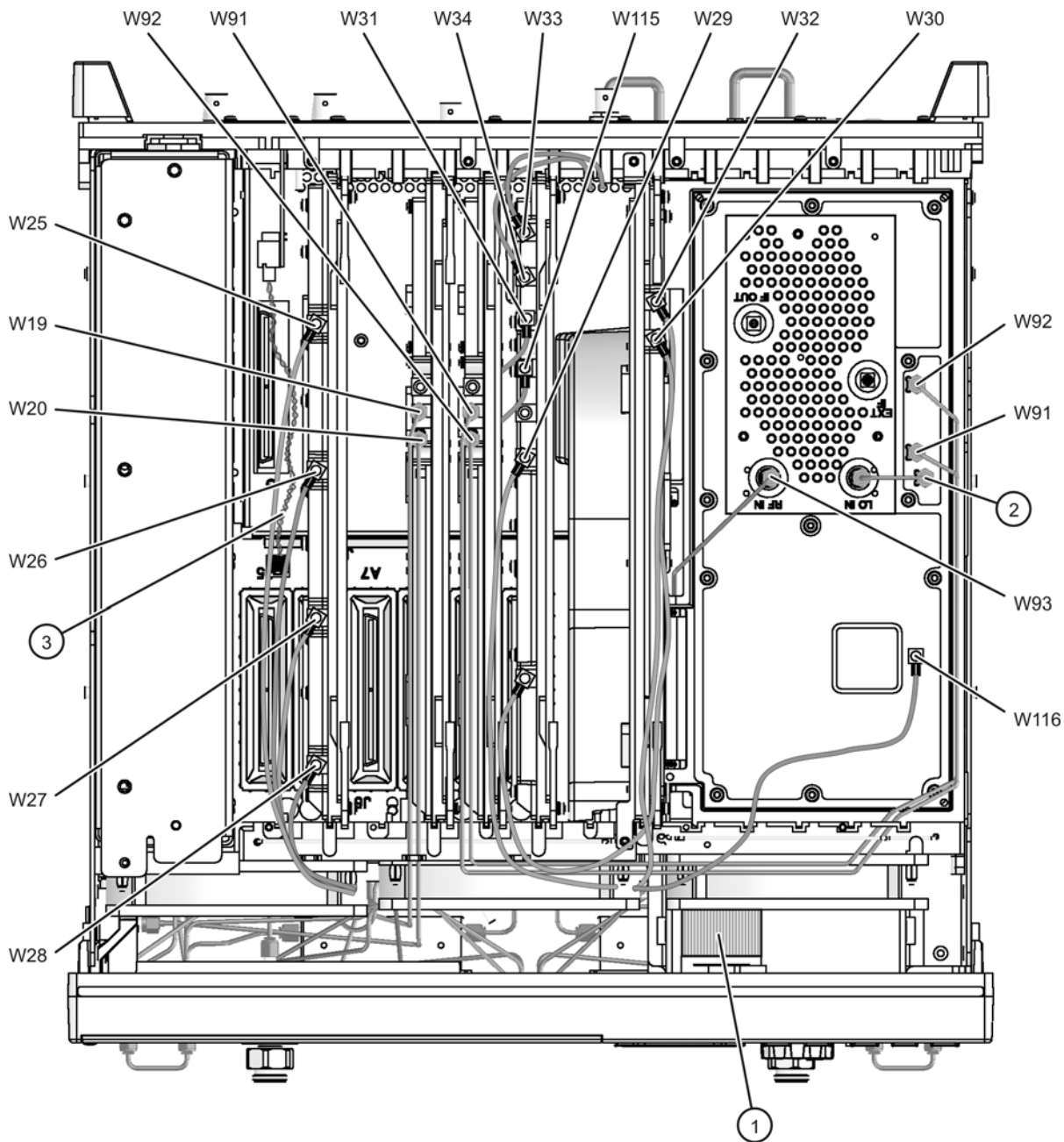

st567b

### Bottom Assemblies, No Options

Ref. Desig.	Models	Part Number <sup>a</sup>	Qty	Description
A16	All	E8364-60138	1	Test set motherboard
A17	All	5087-7127 <i>5087-6127</i>	1	LOMA 10
A18	All	5087-7128 <i>5087-6128</i>	1	MA 20
A19	All	5087-7139	1	Splitter
A20	All	5087-7129 <i>5087-6129</i>	1	LODA
A21	E8363C, E8364C	5087-7130 <i>5087-6130</i>	1	SOMA 50
A22	All	5087-7132 <i>5087-6132</i>	1	Switch splitter
A23 A24	E8363C, E8364C	5087-7133	2	Channel R1 detector Channel R2 detector
A25 A26	E8362C	5086-7968	2	Test port 1 coupler Test port 2 coupler
	E8363C, E8364C	5086-7518	2	Test port 1 coupler Test port 2 coupler
A27 A30	All	5087-7122 <i>5087-6122</i>	2	Channel A first converter (mixer) Channel B first converter (mixer)
A28 A29		5087-7145 <i>5087-6145</i>	2	Channel R1 first converter (mixer) Channel R2 first converter (mixer)
A31 A32 A33 A34	All	E8364-60134	4	Channel A receiver module Channel R1 receiver module Channel R2 receiver module Channel B receiver module
A35	All	E8364-60135	1	Receiver motherboard
A41	All	Hard disk drive assembly. Refer to <a href="#">"Hard Disk Drive Assembly, All Options"</a> on page 6-80.		
A49	All	E8361-60043	1	IF multiplexer board
①	E8362C	08493-60017	2	30-dB fixed attenuator (pad)

a. Part numbers in *italic* typeface are for rebuilt exchange assemblies. Refer to ["Rebuilt-Exchange Assemblies"](#) on page 6-5.



Figure 6-8 Bottom Assemblies, No Options

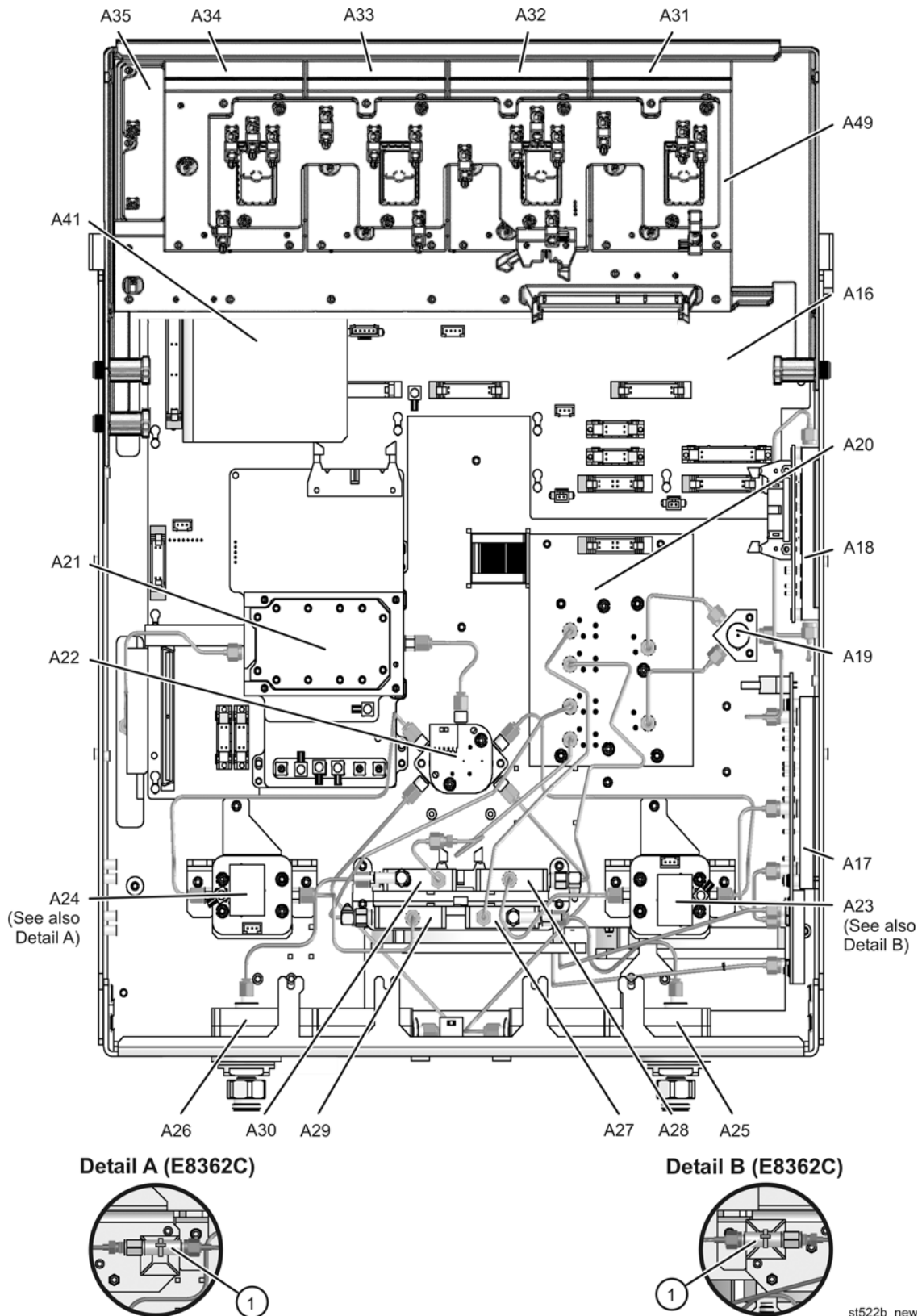

### Bottom Semi-Rigid Cables, No Options

Ref. Desig.	Models	Part Number	Qty	Description
W1	E8362C	E8362-20002	1	A12 source 20 to A22 switch splitter
	E8363C, E8364C	E8364-20036		A12 source 20 to A21 SOMA 50
W2	E8363C, E8364C	E8364-20034	1	A21 SOMA 50 to A22 switch splitter
W3	E8362C	E8362-20003	1	A22 switch splitter to channel R1 30-dB attenuator
	E8363C, E8364C	E8364-20144		A22 switch splitter to A23 detector
W4	E8362C	E8362-20004	1	A22 switch splitter to channel R2 30-dB attenuator
	E8363C, E8364C	E8364-20024		A22 switch splitter to A24 detector
W5	All	E8364-20021	1	A22 switch splitter to A25 test port 1 coupler
W6	All	E8364-20022	1	A22 switch splitter to A26 test port 2 coupler
W7	E8362C	E8362-20005	1	Channel R1 attenuator to A28 channel R1 mixer
	E8363C, E8364C	E8364-20025		A23 detector to A28 channel R1 mixer
W8	E8362C	E8362-20006	1	Channel R2 attenuator to A29 channel R2 mixer
	E8363C, E8364C	E8364-20026		A24 detector to A29 channel R2 mixer
W9	All	E8364-20019	1	A25 test port 1 coupler to A27 channel A mixer
W10	All	E8364-20020	1	A26 test port 2 coupler to A30 channel B mixer
W11	All	E8364-20171	1	A20 LODA to A27 channel A mixer
W12	All	E8364-20172	1	A20 LODA to A28 channel R1 mixer
W13	All	E8364-20173	1	A20 LODA to A29 channel R2 mixer
W14	All	E8364-20146	1	A20 LODA to W40 (to A30 channel B mixer)
W15	All	E8364-20041	1	A19 splitter to A20 LODA
W16	All	E8364-20042	1	A19 splitter to A20 LODA
W17	All	E8364-20029	1	A18 MA 20 to A19 splitter
W18	All	E8364-20145	1	A17 LOMA 10 to A18 MA 20
W19-W20	All	Refer to <a href="#">"Top Cables–All, All Options Except 080"</a> on page 6-16.		
W40	All	E8364-20032	1	W14 (from A20 LODA) to A30 channel B mixer

Figure 6-9 Bottom Semi-Rigid Cables, No Options

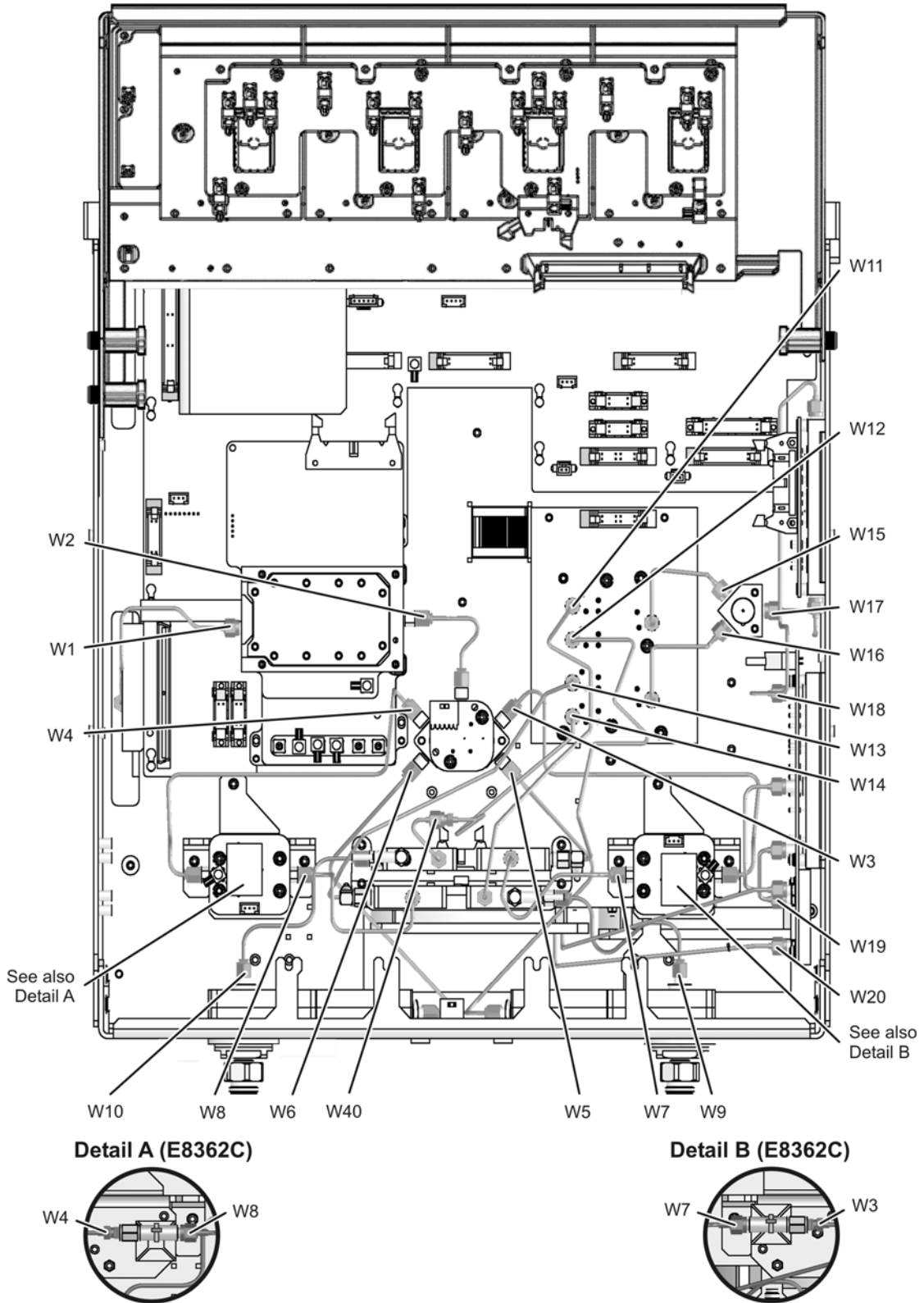

st527b\_new

### Bottom Assemblies, Option UNL

Ref. Desig.	Models	Part Number <sup>a</sup>	Qty	Description
A16	All	E8364-60138	1	Test set motherboard
A17	All	5087-7127 <i>5087-6127</i>	1	LOMA 10
A18	All	5087-7128 <i>5087-6128</i>	1	MA 20
A19	All	5087-7139	1	Splitter
A20	All	5087-7129 <i>5087-6129</i>	1	LODA
A21	E8363C, E8364C	5087-7130 <i>5087-6130</i>	1	SOMA 50
A22	All	5087-7132 <i>5087-6132</i>	1	Switch splitter
A23 A24	E8363C, E8364C	5087-7133	2	Channel R1 detector Channel R2 detector
A25 A26	E8362C	5086-7968	2	Test port 1 coupler Test port 2 coupler
	E8363C, E8364C	5086-7518	2	Test port 1 coupler Test port 2 coupler
A27 A30	All	5087-7122 <i>5087-6122</i>	2	Channel A first converter (mixer) Channel B first converter (mixer)
A28 A29		5087-7145 <i>5087-6145</i>	2	Channel R1 first converter (mixer) Channel R2 first converter (mixer)
A31 A32 A33 A34	All	E8364-60134	4	Channel A receiver module Channel R1 receiver module Channel R2 receiver module Channel B receiver module
A35	All	E8364-60135	1	Receiver motherboard
A36 A37	All	33325-60004	2	Step attenuator, 60-dB, port 1 (source) Step attenuator, 60-dB, port 2 (source)
A38 A39	E8362C	5087-7239	2	Bias tee with cable, port 1 Bias tee with cable, port 2
	E8363C, E8364C	5087-7233	2	Bias tee with cable, port 1 Bias tee with cable, port 2
A41	All	Hard disk drive assembly. Refer to <a href="#">“Hard Disk Drive Assembly, All Options”</a> on page 6-80.		
A49	All	E8361-60043	1	IF multiplexer board
①	E8362C	08493-60017	2	30-dB fixed attenuator (pad)

a. Part numbers in *italic* typeface are for rebuilt exchange assemblies. Refer to [“Rebuilt-Exchange Assemblies”](#) on page 6-5.

**Figure 6-10 Bottom Assemblies, Option UNL**

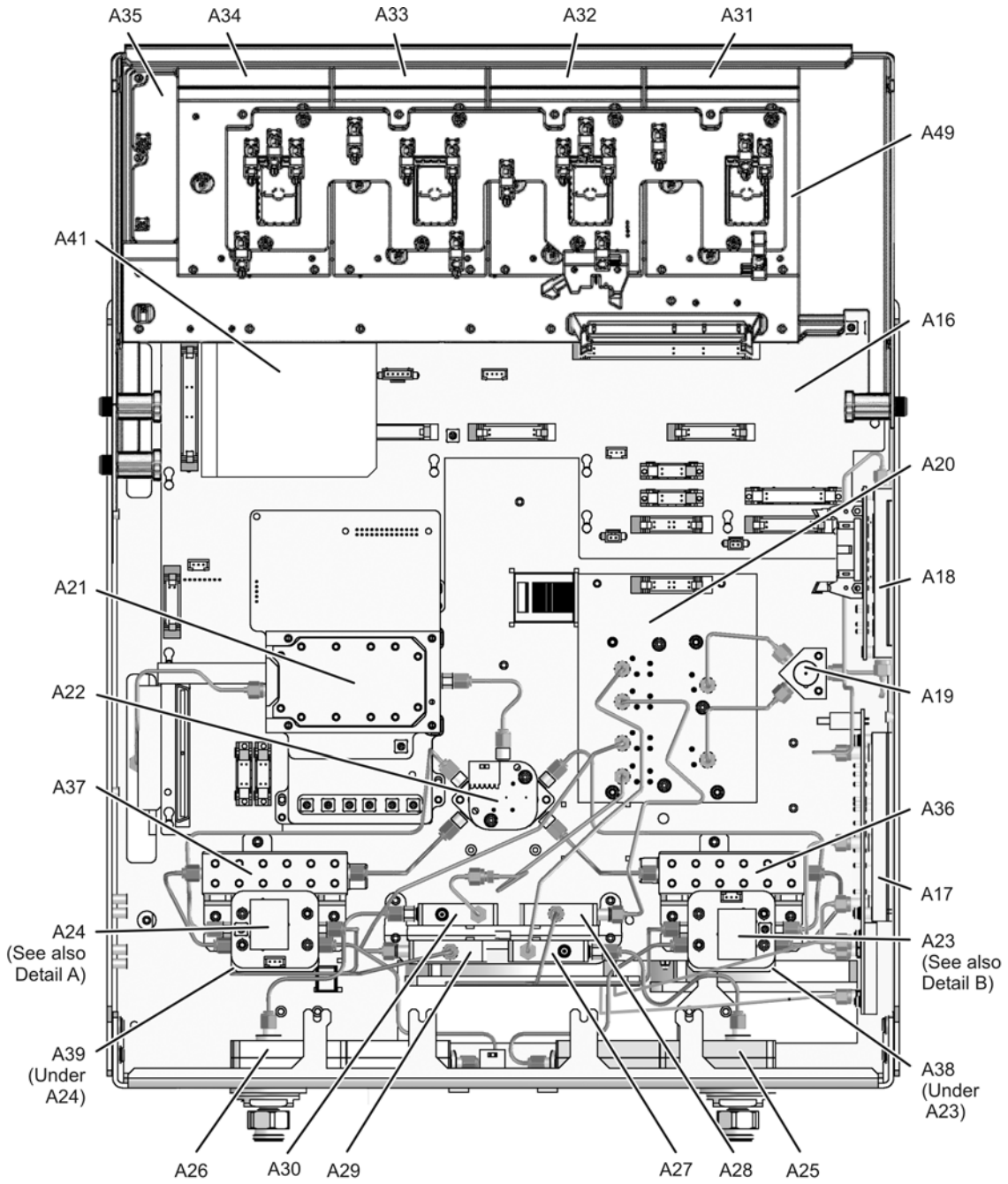

**Detail A (E8362C)**

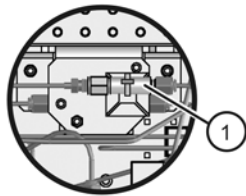

**Detail B (E8362C)**

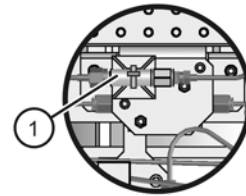

st574b\_new

### Bottom Semi-Rigid Cables, Option UNL

Ref. Desig.	Models	Part Number	Qty	Description
W1	E8362C	E8362-20002	1	A12 source 20 to A22 switch splitter
	E8363C, E8364C	E8364-20036		A12 source 20 to A21 SOMA 50
W2	E8363C, E8364C	E8364-20034	1	A21 SOMA 50 to A22 switch splitter
W3	E8362C	E8362-20003	1	A22 switch splitter to channel R1 30-dB attenuator
	E8363C, E8364C	E8364-20144	1	A22 switch splitter to A23 detector
W4	E8362C	E8362-20004	1	A22 switch splitter to channel R2 30-dB attenuator
	E8363C, E8364C	E8364-20024	1	A22 switch splitter to A24 detector
W7	E8362C	E8362-20027	1	Channel R1 attenuator to A28 channel R1 mixer
	E8363C, E8364C	E8364-20174	1	A23 detector to A28 channel R1 mixer
W8	E8362C	E8362-20028	1	Channel R2 attenuator to A29 channel R2 mixer
	E8363C, E8364C	E8364-20175	1	A24 detector to A29 channel R2 mixer
W9	All	E8364-20019	1	A25 test port 1 coupler to A27 channel A mixer
W10	All	E8364-20020	1	A26 test port 2 coupler to A30 channel B mixer
W11	All	E8364-20171	1	A20 LODA to A27 channel A mixer
W12	All	E8364-20172	1	A20 LODA to A28 channel R1 mixer
W13	All	E8364-20173	1	A20 LODA to A29 channel R2 mixer
W14	All	E8364-20146	1	A20 LODA to W40 (to A30 channel B mixer)
W15	All	E8364-20041	1	A19 splitter to A20 LODA
W16	All	E8364-20042	1	A19 splitter to A20 LODA
W17	All	E8364-20029	1	A18 MA 20 to A19 splitter
W18	All	E8364-20145	1	A17 LOMA 10 to A18 MA 20
W19-W20	All	Refer to <a href="#">"Top Cables--All, All Options Except 080"</a> on page 6-16.		
W40	All	E8364-20032	1	W14 (from A20 LODA) to A30 channel B mixer
W51	All	E8364-20055	1	A22 switch splitter to A36 step attenuator
W52	All	E8364-20056	1	A22 switch splitter to A37 step attenuator
W53	All	E8364-20077	2	A36 step attenuator to A38 bias tee
W54				A37 step attenuator to A39 bias tee
W55	All	E8364-20167	1	A38 bias tee to A25 test port 1 coupler
W56	All	E8364-20168	1	A39 bias tee to A26 test port 2 coupler

**Figure 6-11 Bottom Semi-Rigid Cables, Option UNL**

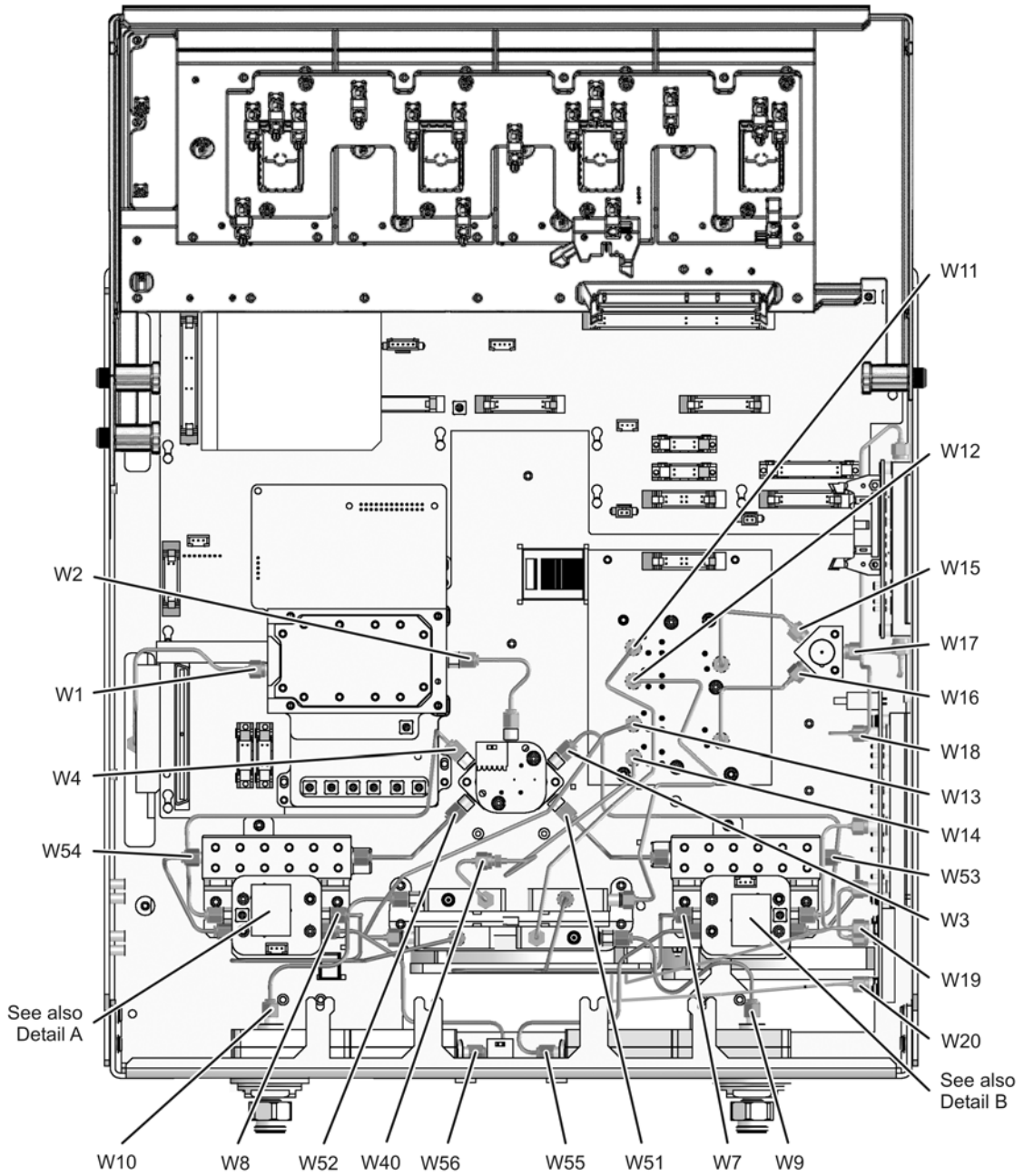

**Detail A (E8362C)**

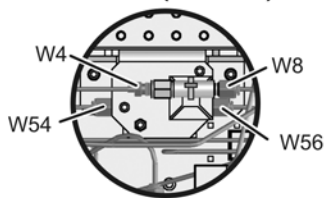

**Detail B (E8362C)**

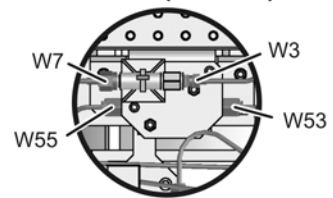

st574cblb\_new

### Bottom Assemblies, Option 014 and Options 014/080

Ref. Desig.	Models	Part Number <sup>a</sup>	Qty	Description
A16	All	E8364-60138	1	Test set motherboard
A17	All	5087-7127 <i>5087-6127</i>	1	LOMA 10
A18	All	5087-7128 <i>5087-6128</i>	1	MA 20
A19	All	5087-7139	1	Splitter
A20	All	5087-7129 <i>5087-6129</i>	1	LODA
A21	E8363C, E8364C	5087-7130 <i>5087-6130</i>	1	SOMA 50
A22	All	5087-7132 <i>5087-6132</i>	1	Switch splitter
A23 A24	E8363C, E8364C	5087-7133	2	Channel R1 detector Channel R2 detector
A25 A26	E8362C	5086-7968	2	Test port 1 coupler Test port 2 coupler
	E8363C, E8364C	5086-7518	2	Test port 1 coupler Test port 2 coupler
A27 A30	All	5087-7122 <i>5087-6122</i>	2	Channel A first converter (mixer) Channel B first converter (mixer)
A28 A29		5087-7145 <i>5087-6145</i>	2	Channel R1 first converter (mixer) Channel R2 first converter (mixer)
A31 A32 A33 A34	All	E8364-60134	4	Channel A receiver module Channel R1 receiver module Channel R2 receiver module Channel B receiver module
A35	All	E8364-60135	1	Receiver motherboard
A41	All	Hard disk drive assembly. Refer to <a href="#">"Hard Disk Drive Assembly, All Options"</a> on page 6-80.		
A49	All	E8361-60043	1	IF multiplexer board
①	E8362C	08493-60017	2	30-dB fixed attenuator (pad)

a. Part numbers in *italic* typeface are for rebuilt exchange assemblies. Refer to ["Rebuilt-Exchange Assemblies"](#) on page 6-5.



Figure 6-12 Bottom Assemblies, Option 014 and Options 014/080

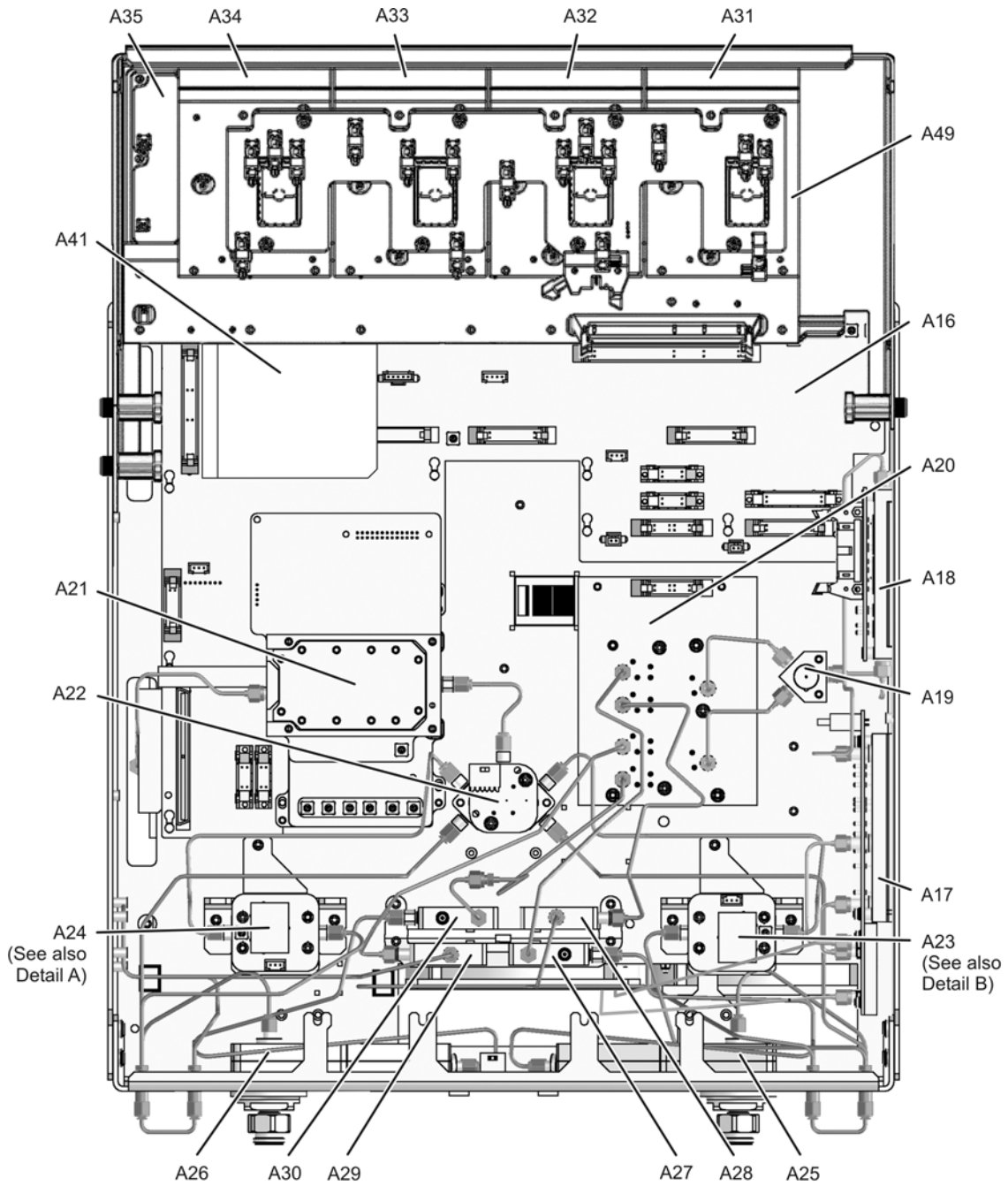

Detail A (E8362C)

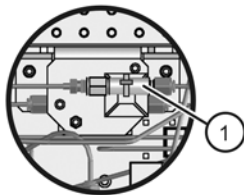

Detail B (E8362C)

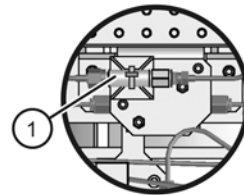

st575b\_new

**Bottom Semi-Rigid Cables, Options 014 and 014/080**

Ref. Desig.	Models	Part Number	Qty	Description
W1	E8362C	E8362-20002	1	A12 source 20 to A22 switch splitter
	E8363C, E8364C	E8364-20036		A12 source 20 to A21 SOMA 50
W2	E8363C, E8364C	E8364-20034	1	A21 SOMA 50 to A22 switch splitter
W3	E8362C	E8362-20003	1	A22 switch splitter to channel R1 30-dB attenuator
	E8363C, E8364C	E8364-20144		A22 switch splitter to A23 detector
W4	E8362C	E8362-20004	1	A22 switch splitter to channel R2 30-dB attenuator
	E8363C, E8364C	E8364-20024		A22 switch splitter to A24 detector
W11	All	E8364-20171	1	A20 LODA to A27 channel A mixer
W12	All	E8364-20172	1	A20 LODA to A28 channel R1 mixer
W13	All	E8364-20173	1	A20 LODA to A29 channel R2 mixer
W14	All	E8364-20146	1	A20 LODA to W40 (to A30 channel B mixer)
W15	All	E8364-20041	1	A19 splitter to A20 LODA
W16	All	E8364-20042	1	A19 splitter to A20 LODA
W17	All	E8364-20029	1	A18 MA 20 to A19 splitter
W18	All	E8364-20145	1	A17 LOMA 10 to A18 MA 20
W19-W20	All	Refer to "Top Cables--All, All Options Except 080" on page 6-16.		
W40	All	E8364-20032	1	W14 (from A20 LODA) to A30 channel B mixer
W60	E8362C	08720-20098	6	Front-panel jumper
	E8363C, E8364C	E8364-20059		
W61	E8362C	E8362-20016	1	A22 switch splitter to port 1 SOURCE OUT
	E8363C, E8364C	E8364-20081		
W62	E8362C	E8362-20017	1	A22 switch splitter to port 2 SOURCE OUT
	E8363C, E8364C	E8364-20082		
W63	E8362C	E8362-20018	1	Port 1 CPLR THRU to A25 test port 1 coupler
	E8363C, E8364C	E8364-20073		
W64	E8362C	E8362-20019	1	Port 2 CPLR THRU to A26 test port 2 coupler
	E8363C, E8364C	E8364-20074		
W65	E8362C	E8362-20007	1	Channel R1 attenuator to channel R1 SOURCE OUT
	E8363C, E8364C	E8364-20047		A23 detector to channel R1 SOURCE OUT
W66	E8362C	E8362-20053	1	Channel R2 attenuator to channel R2 SOURCE OUT
	E8363C, E8364C	E8364-20048		A24 detector to channel R2 SOURCE OUT
W67	E8362C	E8362-20020	1	A25 test port 1 coupler to Port 1 CPLR ARM
	E8363C, E8364C	E8364-20043		
W68	E8362C	E8362-20021	1	A26 test port 2 coupler to Port 2 CPLR ARM
	E8363C, E8364C	E8364-20044		
W69	E8362C	E8362-20022	1	A IN to A27 channel A mixer
	E8363C, E8364C	E8364-20045		
W70	E8362C	E8362-20029	1	R1 IN to A28 channel R1 mixer
	E8363C, E8364C	E8364-20075		
W71	E8362C	E8362-20030	1	R2 IN to A29 channel R2 mixer
	E8363C, E8364C	E8364-20076		
W72	E8362C	E8362-20023	1	B IN to A30 channel B mixer
	E8363C, E8364C	E8364-20046		

**Figure 6-13 Bottom Semi-Rigid Cables, Option 014 and Options 014/080**

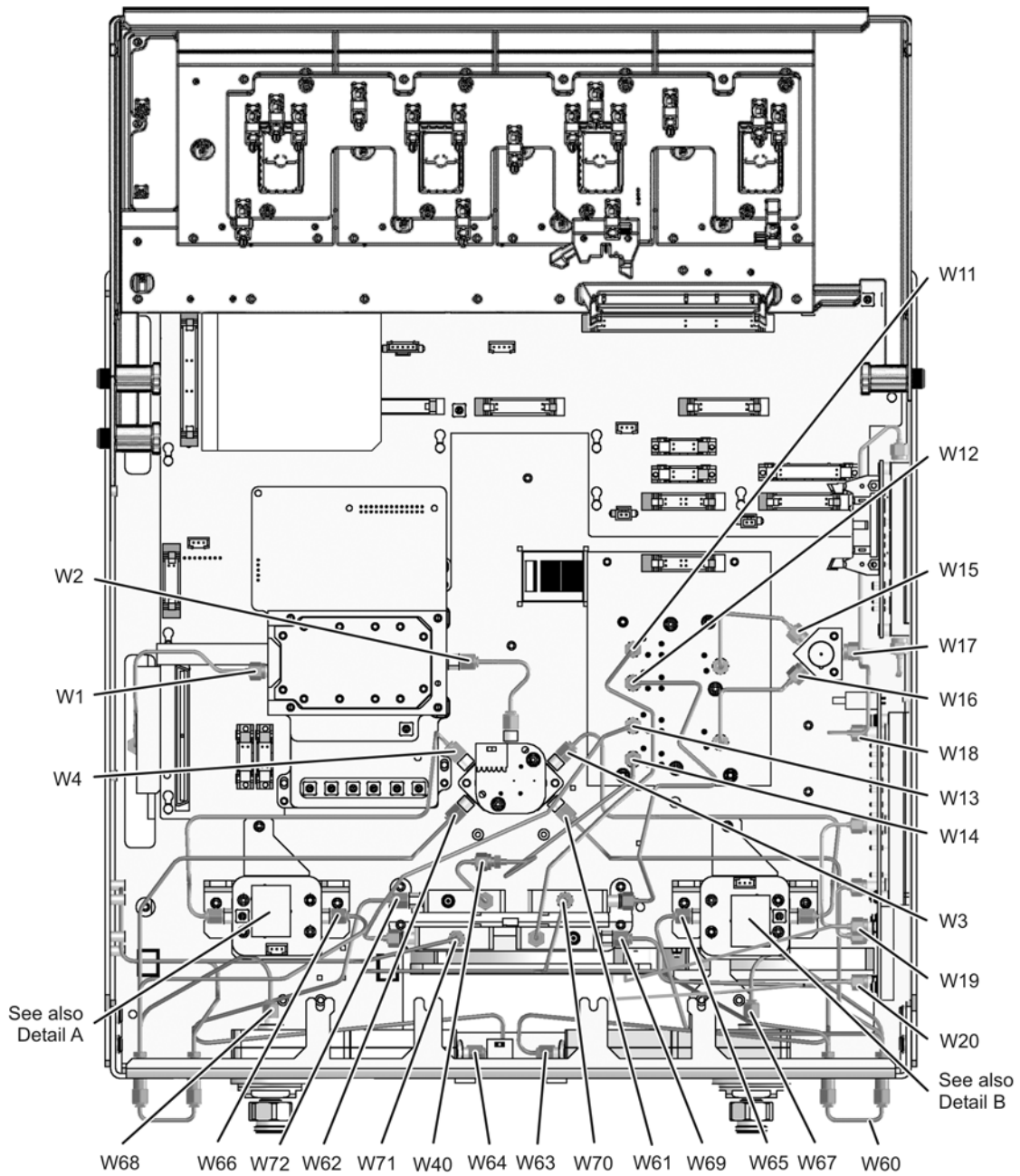

**Detail A (E8362C)**

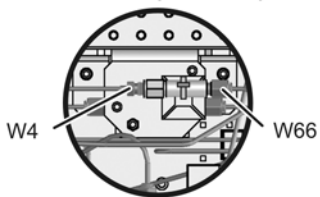

**Detail B (E8362C)**

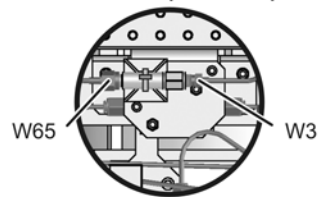

st575cblb\_new

**Bottom Assemblies, Options UNL/014 and UNL/014/080**

Ref. Desig.	Models	Part Number <sup>a</sup>	Qty	Description
A16	All	E8364-60138	1	Test set motherboard
A17	All	5087-7127 <i>5087-6127</i>	1	LOMA 10
A18	All	5087-7128 <i>5087-6128</i>	1	MA 20
A19	All	5087-7139	1	Splitter
A20	All	5087-7129 <i>5087-6129</i>	1	LODA
A21	E8363C, E8364C	5087-7130 <i>5087-6130</i>	1	SOMA 50
A22	All	5087-7132 <i>5087-6132</i>	1	Switch splitter
A23 A24	E8363C, E8364C	5087-7133	2	Channel R1 detector Channel R2 detector
A25 A26	E8362C	5086-7968	2	Test port 1 coupler Test port 2 coupler
A25 A26	E8363C, E8364C	5086-7518	2	Test port 1 coupler Test port 2 coupler
A27 A30	All	5087-7122 <i>5087-6122</i>	2	Channel A first converter (mixer) Channel B first converter (mixer)
A28 A29		5087-7145 <i>5087-6145</i>	2	Channel R1 first converter (mixer) Channel R2 first converter (mixer)
A31 A32 A33 A34	All	E8364-60134	4	Channel A receiver module Channel R1 receiver module Channel R2 receiver module Channel B receiver module
A35	All	E8364-60135	1	Receiver motherboard
A36 A37	All	33325-60004	2	Step attenuator, 60-dB, port 1 (source) Step attenuator, 60-dB, port 2 (source)
A38 A39	E8362C	5086-7239	2	Bias tee with cable, port 1 Bias tee with cable, port 2
A38 A39	E8363C, E8364C	5087-7233	2	Bias tee with cable, port 1 Bias tee with cable, port 2
A41	All	Hard disk drive assembly. Refer to <a href="#">"Hard Disk Drive Assembly, All Options"</a> on page 6-80.		
A49	All	E8361-60043	1	IF multiplexer board
①	E8362C	08493-60017	2	30-dB fixed attenuator (pad)

a. Part numbers in *italic* typeface are for rebuilt exchange assemblies. Refer to ["Rebuilt-Exchange Assemblies"](#) on page 6-5.

Figure 6-14 Bottom Assemblies, Options UNL/014 and UNL/014/080

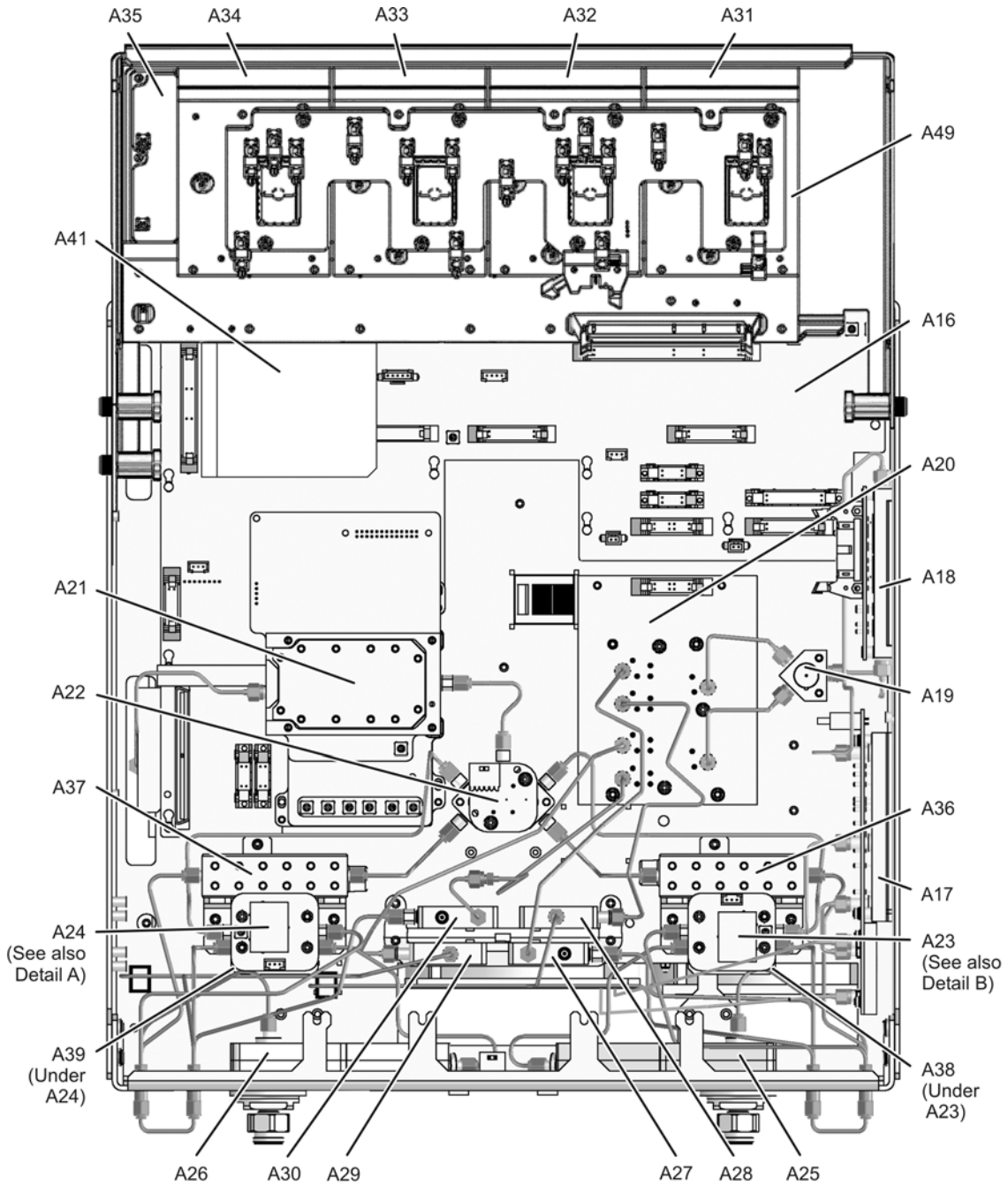

Detail A (E8362C)

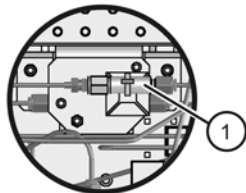

Detail B (E8362C)

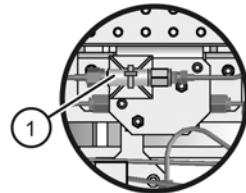

st578b\_new

**Bottom Semi-Rigid Cables, Options UNL/014 and UNL/014/080**

Ref. Desig.	Models	Part Number	Qty	Description
W1	E8362C	E8362-20002	1	A12 source 20 to A22 switch splitter
	E8363C, E8364C	E8364-20036		A12 source 20 to A21 SOMA 50
W2	E8363C, E8364C	E8364-20034	1	A21 SOMA 50 to A22 switch splitter
W3	E8362C	E8362-20003	1	A22 switch splitter to channel R1 30-dB attenuator
	E8363C, E8364C	E8364-20144		A22 switch splitter to A23 detector
W4	E8362C	E8362-20004	1	A22 switch splitter to channel R2 30-dB attenuator
	E8363C, E8364C	E8364-20024		A22 switch splitter to A24 detector
W11	All	E8364-20171	1	A20 LODA to A27 channel A mixer
W12	All	E8364-20172	1	A20 LODA to A28 channel R1 mixer
W13	All	E8364-20173	1	A20 LODA to A29 channel R2 mixer
W14	All	E8364-20146	1	A20 LODA to W40 (to A30 channel B mixer)
W15	All	E8364-20041	1	A19 splitter to A20 LODA
W16	All	E8364-20042	1	A19 splitter to A20 LODA
W17	All	E8364-20029	1	A18 MA 20 to A19 splitter
W18	All	E8364-20145	1	A17 LOMA 10 to A18 MA 20
W19-W20	All	Refer to <a href="#">"Top Cables--All, All Options Except 080"</a> on page 6-16.		
W40	All	E8364-20032	1	W14 (from A20 LODA) to A30 channel B mixer
W51	All	E8364-20055	1	A22 switch splitter to A36 step attenuator
W52	All	E8364-20056	1	A22 switch splitter to A37 step attenuator
W55	All	E8364-20167	1	A38 bias tee to A25 test port 1 coupler
W56	All	E8364-20168	1	A39 bias tee to A26 test port 2 coupler
W60	E8362C	08720-20098	6	Front-panel jumper
	E8363C, E8364C	E8364-20059		Front-panel jumper
W65	E8362C	E8362-20007	1	Channel R1 attenuator to channel R1 SOURCE OUT
	E8363C, E8364C	E8364-20047		A23 detector to channel R1 SOURCE OUT
W66	E8362C	E8362-20008	1	Channel R2 attenuator to channel R2 SOURCE OUT
	E8363C, E8364C	E8364-20048		A24 detector to channel R2 SOURCE OUT
W67	E8362C	E8362-20020	1	A25 test port 1 coupler to Port 1 CPLR ARM
	E8363C, E8364C	E8364-20043		A25 test port 1 coupler to Port 1 CPLR ARM
W68	E8362C	E8362-20021	1	A26 test port 2 coupler to Port 2 CPLR ARM
	E8363C, E8364C	E8364-20044		A26 test port 2 coupler to Port 2 CPLR ARM
W69	E8362C	E8362-20022	1	A IN to A27 channel A mixer
	E8363C, E8364C	E8364-20045		A IN to A27 channel A mixer
W70	E8362C	E8362-20014	1	R1 IN to A28 channel R1 mixer
	E8363C, E8364C	E8364-20176		R1 IN to A28 channel R1 mixer
W71	E8362C	E8362-20015	1	R2 IN to A29 channel R2 mixer
	E8363C, E8364C	E8364-20177		R2 IN to A29 channel R2 mixer
W72	E8362C	E8362-20023	1	B IN to A30 channel B mixer
	E8363C, E8364C	E8364-20046		B IN to A30 channel B mixer
W81	E8362C	E8362-20024	1	A36 step attenuator to port 1 SOURCE OUT
	E8363C, E8364C	E8364-20053		A36 step attenuator to port 1 SOURCE OUT
W82	E8362C	E8362-20025	1	A37 step attenuator to port 2 SOURCE OUT
	E8363C, E8364C	E8364-20054		A37 step attenuator to port 2 SOURCE OUT
W83	E8362C	E8362-20012	1	Port 1 CPLR THRU to A38 bias tee
	E8363C, E8364C	E8364-20039		Port 1 CPLR THRU to A38 bias tee
W84	E8362C	E8362-20013	1	Port 2 CPLR THRU to A39 bias tee
	E8363C, E8364C	E8364-20040		Port 2 CPLR THRU to A39 bias tee

**Figure 6-15 Bottom Semi-Rigid Cables, Options UNL/014 and UNL/014/080**

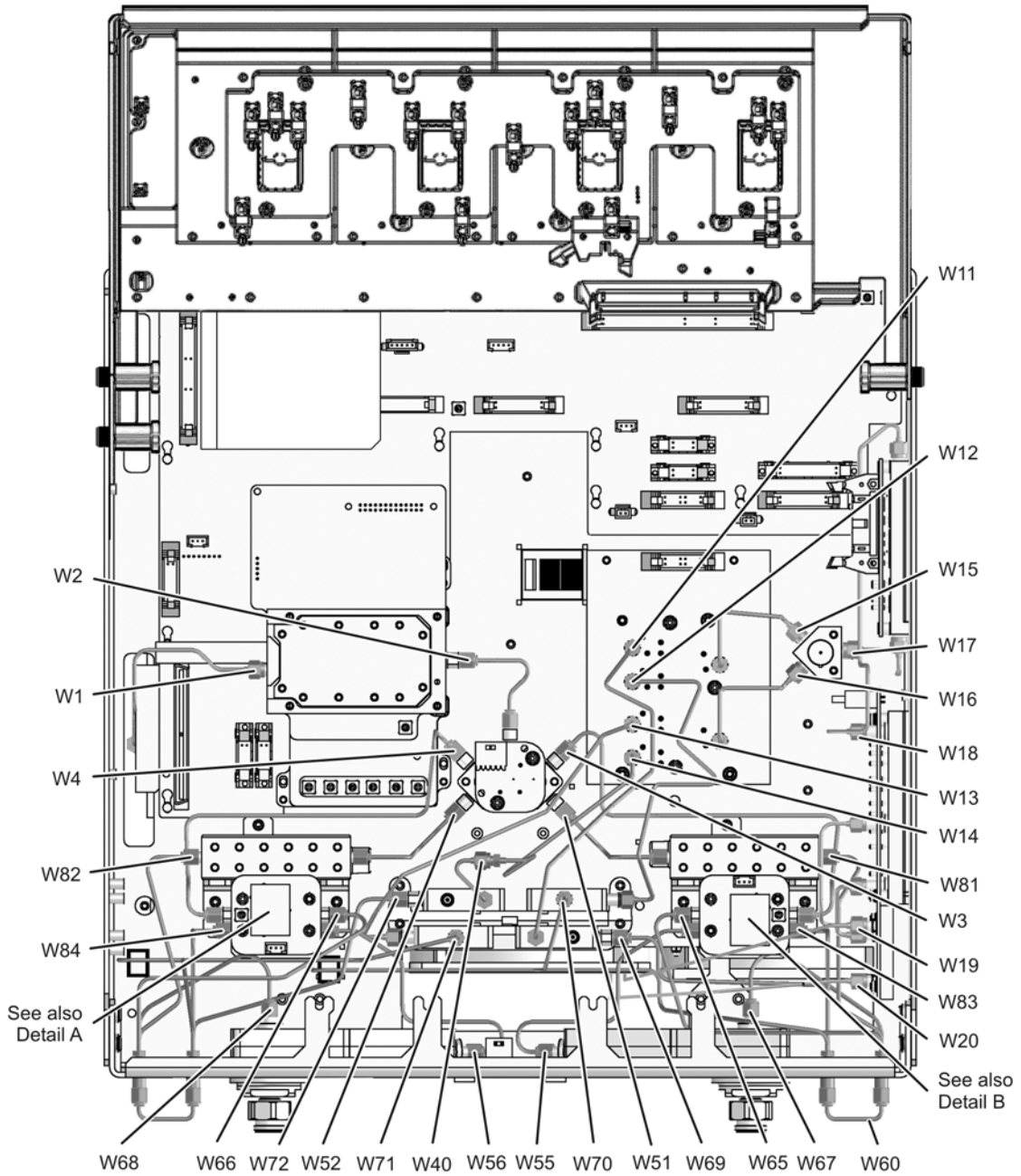

**Detail A (E8362C)**

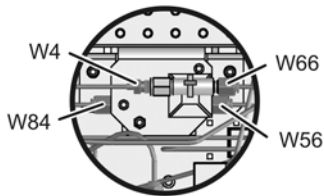

**Detail B (E8362C)**

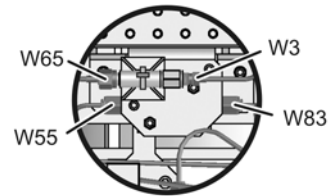

st578cblib\_new

### Bottom Assemblies, Options UNL/016

Ref. Desig.	Models	Part Number <sup>a</sup>	Qty	Description
A16	All	E8364-60138	1	Test set motherboard
A17	All	5087-7127 <i>5087-6127</i>	1	LOMA 10
A18	All	5087-7128 <i>5087-6128</i>	1	MA 20
A19	All	5087-7139	1	Splitter
A20	All	5087-7129 <i>5087-6129</i>	1	LODA
A21	E8363C, E8364C	5087-7130 <i>5087-6130</i>	1	SOMA 50
A22	All	5087-7132 <i>5087-6132</i>	1	Switch splitter
A23 A24	E8363C, E8364C	5087-7133	2	Channel R1 detector Channel R2 detector
A25 A26	E8362C	5086-7968	2	Test port 1 coupler Test port 2 coupler
A25 A26	E8363C, E8364C	5086-7518	2	Test port 1 coupler Test port 2 coupler
A27 A30	All	5087-7122 <i>5087-6122</i>	2	Channel A first converter (mixer) Channel B first converter (mixer)
A28 A29		5087-7145 <i>5087-6145</i>	2	Channel R1 first converter (mixer) Channel R2 first converter (mixer)
A31 A32 A33 A34	All	E8364-60134	4	Channel A receiver module Channel R1 receiver module Channel R2 receiver module Channel B receiver module
A35	All	E8364-60135	1	Receiver motherboard
A36 A37	All	33325-60004	2	Step attenuator, 60-dB, port 1 (source) Step attenuator, 60-dB, port 2 (source)
A38 A39	E8362C	5086-7239	2	Bias tee with cable, port 1 Bias tee with cable, port 2
A38 A39	E8363C, E8364C	5087-7233	2	Bias tee with cable, port 1 Bias tee with cable, port 2
A41	All	Hard disk drive assembly. Refer to <a href="#">“Hard Disk Drive Assembly, All Options”</a> on page 6-80.		
A43 A44	All	33325-60011	2	Step attenuator, 35-dB, port 1 (receiver) Step attenuator, 35-dB, port 2 (receiver)
A49	All	E8361-60043	1	IF multiplexer board
①	E8362C	08493-60017	2	30-dB fixed attenuator (pad)

a. Part numbers in *italic* typeface are for rebuilt exchange assemblies. Refer to [“Rebuilt-Exchange Assemblies”](#) on page 6-5.



**Figure 6-16 Bottom Assemblies, Options UNL/016**

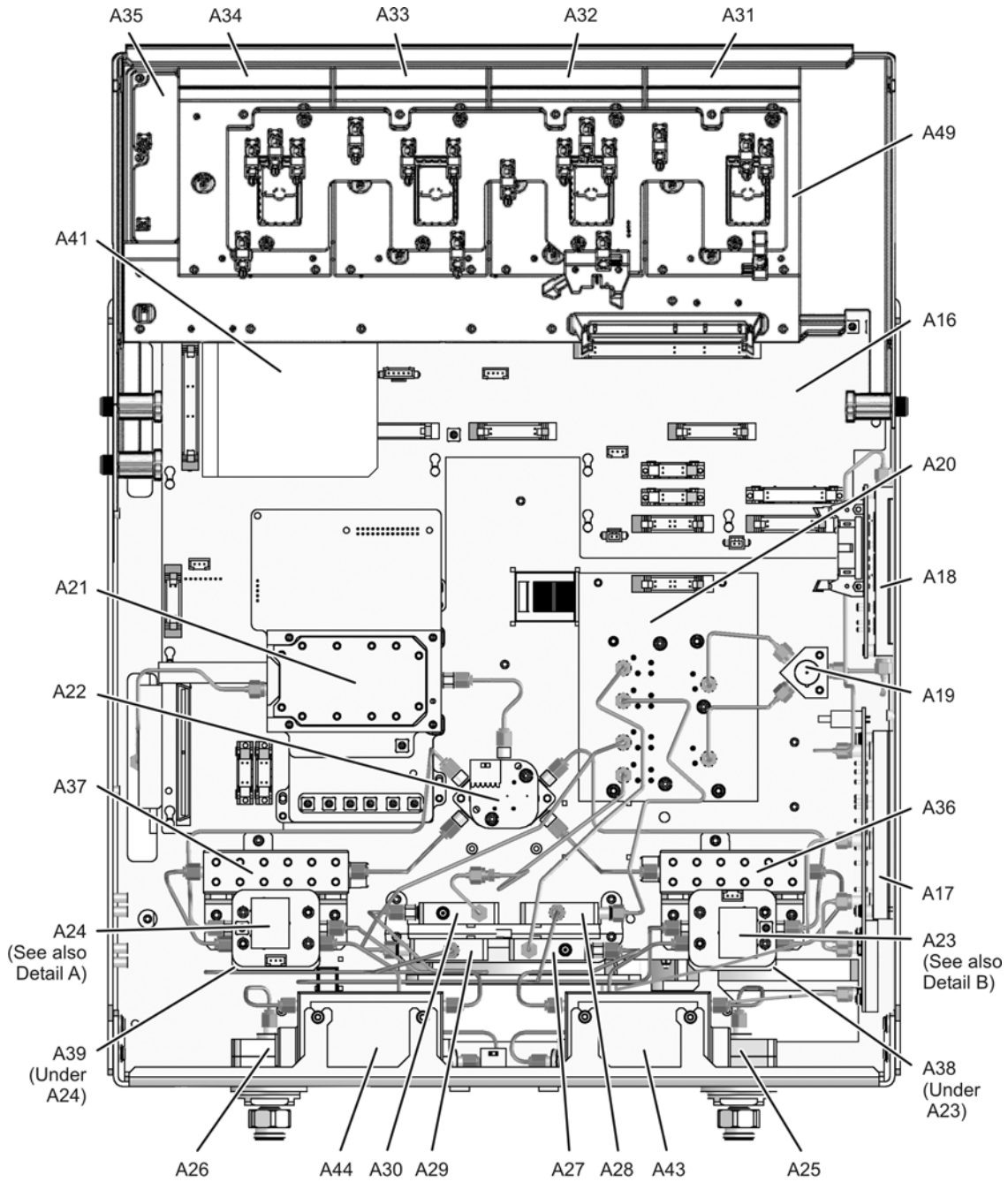

**Detail A (E8362C)**

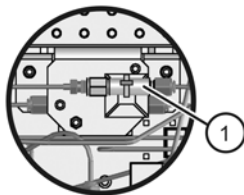

**Detail B (E8362C)**

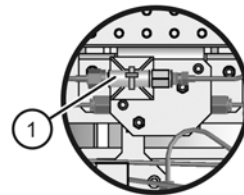

st577b\_new

### Bottom Semi-Rigid Cables, Options UNL/016

Ref. Desig.	Models	Part Number	Qty	Description
W1	E8362C	E8362-20002	1	A12 source 20 to A22 switch splitter
	E8363C, E8364C	E8364-20036		A12 source 20 to A21 SOMA 50
W2	E8363C, E8364C	E8364-20034	1	A21 SOMA 50 to A22 switch splitter
W3	E8362C	E8362-20003	1	A22 switch splitter to channel R1 30-dB attenuator
	E8363C, E8364C	E8364-20144		A22 switch splitter to A23 detector
W4	E8362C	E8362-20004	1	A22 switch splitter to channel R2 30-dB attenuator
	E8363C, E8364C	E8364-20024		A22 switch splitter to A24 detector
W7	E8362C	E8362-20039	1	Channel R1 attenuator to A28 channel R1 mixer
	E8363C, E8364C	E8364-20149		A23 detector to A28 channel R1 mixer
W8	E8362C	E8362-20040	1	Channel R2 attenuator to A29 channel R2 mixer
	E8363C, E8364C	E8364-20150		A24 detector to A29 channel R2 mixer
W9	All	E8364-20019	1	A25 test port 1 coupler to A27 channel A mixer
W10	All	E8364-20020	1	A26 test port 2 coupler to A30 channel B mixer
W11	All	E8364-20171	1	A20 LODA to A27 channel A mixer
W12	All	E8364-20172	1	A20 LODA to A28 channel R1 mixer
W13	All	E8364-20173	1	A20 LODA to A29 channel R2 mixer
W14	All	E8364-20146	1	A20 LODA to W40 (to A30 channel B mixer)
W15	All	E8364-20041	1	A19 splitter to A20 LODA
W16	All	E8364-20042	1	A19 splitter to A20 LODA
W17	All	E8364-20029	1	A18 MA 20 to A19 splitter
W18	All	E8364-20145	1	A17 LOMA 10 to A18 MA 20
W19-W20	All	Refer to "Top Cables--All, All Options Except 080" on page 6-16.		
W40	All	E8364-20032	1	W14 (from A20 LODA) to A30 channel B mixer
W45	All	E8364-20147	1	A25 test port 1 coupler to A43 channel A step attenuator
W46	All	E8364-20148	1	A26 test port 2 coupler to A44 channel B step attenuator
W47	All	E8364-20131	1	A43 channel A step attenuator to A27 channel A mixer
W48	All	E8364-20132	1	A44 channel B step attenuator to A30 channel B mixer
W51	All	E8364-20055	1	A22 switch splitter to A36 step attenuator
W52	All	E8364-20056	1	A22 switch splitter to A37 step attenuator
W53	All	E8364-20077	2	A36 step attenuator to A38 bias tee
W54				A37 step attenuator to A39 bias tee
W55	All	E8364-20167	1	A38 bias tee to A25 test port 1 coupler
W56	All	E8364-20168	1	RF cable: A39 bias tee to A26 test port 2 coupler

**Figure 6-17 Bottom Semi-Rigid Cables, Options UNL/016**

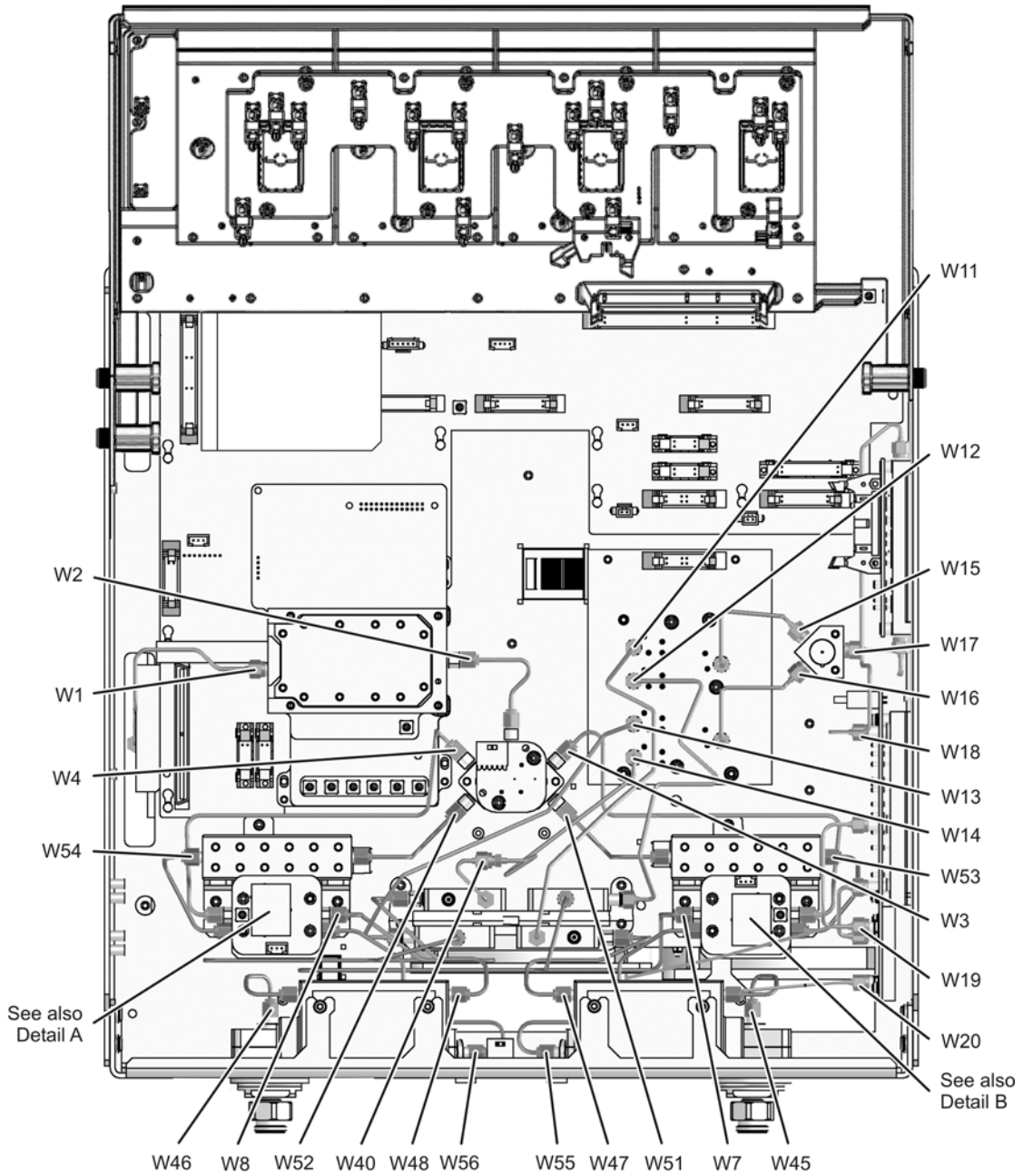

**Detail A (E8362C)**

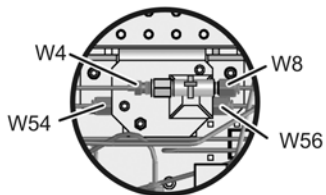

**Detail B (E8362C)**

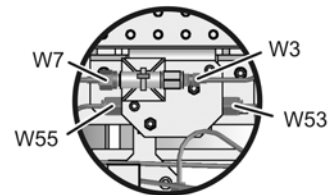

st577cblb\_new

**Bottom Assemblies, Options UNL/014/016 and UNL/014/016/080**

Ref. Desig.	Models	Part Number <sup>a</sup>	Qty	Description
A16	All	E8364-60138	1	Test set motherboard
A17	All	5087-7127 5087-6127	1	LOMA 10
A18	All	5087-7128 5087-6128	1	MA 20
A19	All	5087-7139	1	Splitter
A20	All	5087-7129 5087-6129	1	LODA
A21	E8363C, E8364C	5087-7130 5087-6130	1	SOMA 50
A22	All	5087-7132 5087-6132	1	Switch splitter
A23 A24	E8363C, E8364C	5087-7133	2	Channel R1 detector Channel R2 detector
A25 A26	E8362C	5086-7968	2	Test port 1 coupler Test port 2 coupler
A25 A26	E8363C, E8364C	5086-7518	2	Test port 1 coupler Test port 2 coupler
A27 A30	All	5087-7122 5087-6122	2	Channel A first converter (mixer) Channel B first converter (mixer)
A28 A29		5087-7145 5087-6145	2	Channel R1 first converter (mixer) Channel R2 first converter (mixer)
A31 A32 A33 A34	All	E8364-60134	4	Channel A receiver module Channel R1 receiver module Channel R2 receiver module Channel B receiver module
A35	All	E8364-60135	1	Receiver motherboard
A36 A37	All	33325-60004	2	Step attenuator, 60-dB, port 1 (source) Step attenuator, 60-dB, port 2 (source)
A38 A39	E8362C	5086-7239	2	Bias tee with cable, port 1 Bias tee with cable, port 2
A38 A39	E8363C, E8364C	5087-7233	2	Bias tee with cable, port 1 Bias tee with cable, port 2
A41	All	Hard disk drive assembly. Refer to <a href="#">“Hard Disk Drive Assembly, All Options”</a> on page 6-80.		
A43 A44	All	33325-60011	2	Step attenuator, 35-dB, port 1 (receiver) Step attenuator, 35-dB, port 2 (receiver)
A49	All	E8361-60043	1	IF multiplexer board
①	E8362C	08493-60017	2	30-dB fixed attenuator (pad)

a. Part numbers in *italic* typeface are for rebuilt exchange assemblies. Refer to [“Rebuilt-Exchange Assemblies”](#) on page 6-5.

**Figure 6-18 Bottom Assemblies, Options UNL/014/016 and UNL/014/016/080**

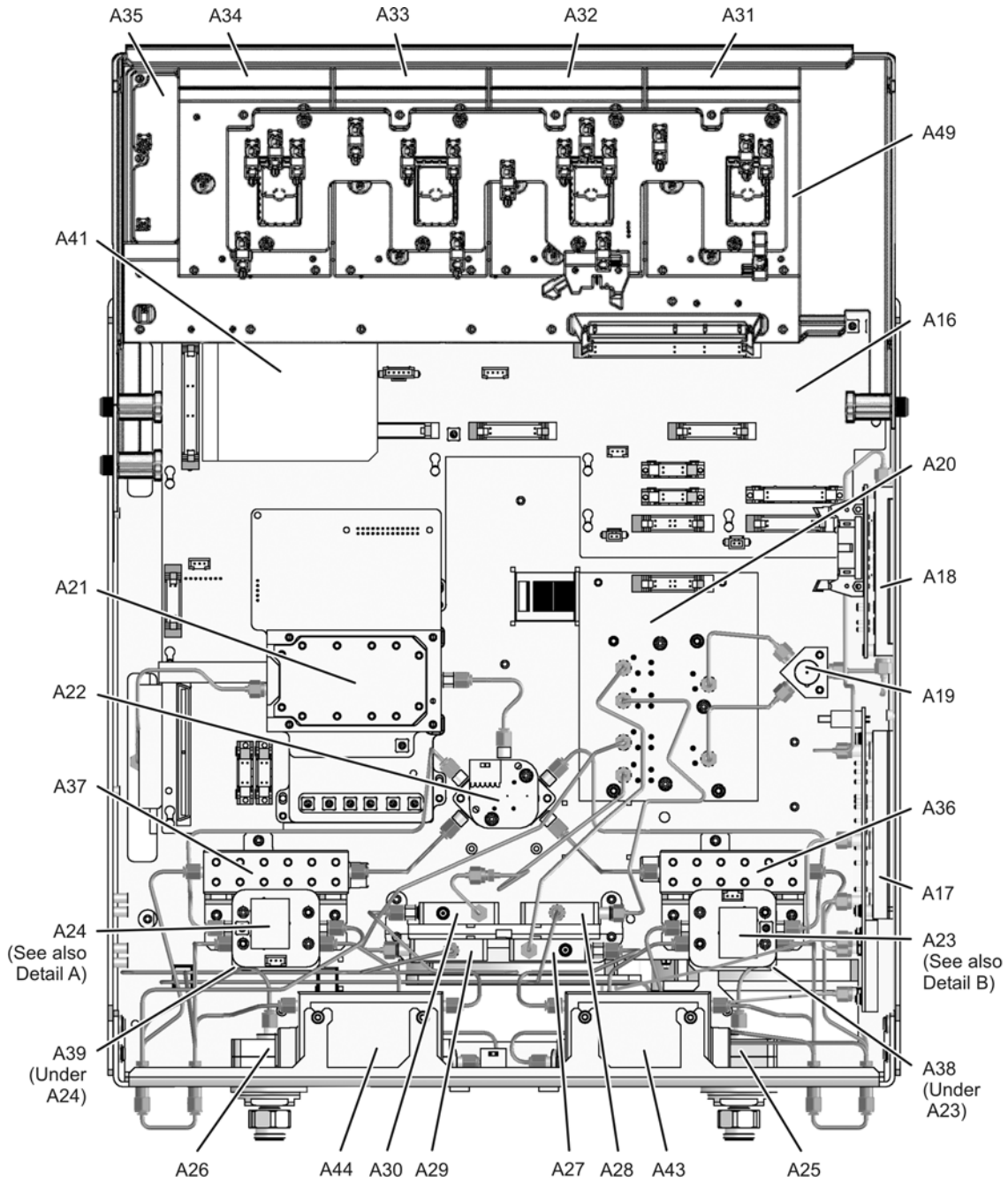

**Detail A (E8362C)**

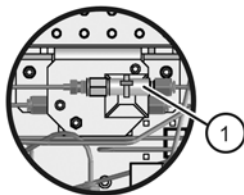

**Detail B (E8362C)**

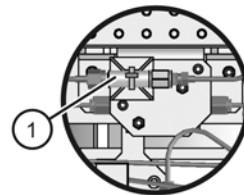

st579b\_new

**Bottom Semi-Rigid Cables, Options UNL/014/016 and UNL/014/016/080**

Ref. Desig.	Models	Part Number	Qty	Description
W1	E8362C	E8362-20002	1	A12 source 20 to A22 switch splitter
	E8363C, E8364C	E8364-20036		A12 source 20 to A21 SOMA 50
W2	E8363C, E8364C	E8364-20034	1	A21 SOMA 50 to A22 switch splitter
W3	E8362C	E8362-20003	1	A22 switch splitter to channel R1 30-dB attenuator
	E8363C, E8364C	E8364-20144		A22 switch splitter to A23 detector
W4	E8362C	E8362-20004	1	A22 switch splitter to channel R2 30-dB attenuator
	E8363C, E8364C	E8364-20024		A22 switch splitter to A24 detector
W11	All	E8364-20171	1	A20 LODA to A27 channel A mixer
W12	All	E8364-20172	1	A20 LODA to A28 channel R1 mixer
W13	All	E8364-20173	1	A20 LODA to A29 channel R2 mixer
W14	All	E8364-20146	1	A20 LODA to W40 (to A30 channel B mixer)
W15	All	E8364-20041	1	A19 splitter to A20 LODA
W16	All	E8364-20042	1	A19 splitter to A20 LODA
W17	All	E8364-20029	1	A18 MA 20 to A19 splitter
W18	All	E8364-20145	1	A17 LOMA 10 to A18 MA 20
W19-W20	All	Refer to "Top Cables--All, All Options Except 080" on page 6-16.		
W40	All	E8364-20032	1	W14 (from A20 LODA) to A30 channel B mixer
W47	All	E8364-20131	1	A43 channel A step attenuator to A27 channel A mixer
W48	All	E8364-20132	1	A44 channel B step attenuator to A30 channel B mixer
W49	E8362C	E8362-20035	1	A IN to A43 channel A step attenuator
	E8363C, E8364C	E8364-20129		
W50	E8362C	E8362-20036	1	B IN to A44 channel B step attenuator
	E8363C, E8364C	E8364-20130		
W51	All	E8364-20055	1	A22 switch splitter to A36 step attenuator
W52	All	E8364-20056	1	A22 switch splitter to A37 step attenuator
W55	All	E8364-20167	1	A38 bias tee to A25 test port 1 coupler
W56	All	E8364-20168	1	A39 bias tee to A26 test port 2 coupler
W60	E8362C	08720-20098	6	Front-panel jumper
	E8363C, E8364C	E8364-20059		
W65	E8362C	E8362-20007	1	Channel R1 attenuator to channel R1 SOURCE OUT
	E8363C, E8364C	E8364-20047	1	A23 detector to channel R1 SOURCE OUT
W66	E8362C	E8362-20053	1	Channel R2 attenuator to channel R2 SOURCE OUT
	E8363C, E8364C	E8364-20048	1	A24 detector to channel R2 SOURCE OUT
W67	E8362C	E8362-20020	1	A25 test port 1 coupler to Port 1 CPLR ARM
	E8363C, E8364C	E8364-20043		
W68	E8362C	E8362-20021	1	A26 test port 2 coupler to Port 2 CPLR ARM
	E8363C, E8364C	E8364-20044		
W70	E8362C	E8362-20041	1	R1 IN to A28 channel R1 mixer
	E8363C, E8364C	E8364-20151		
W71	E8362C	E8362-20038	1	R2 IN to A29 channel R2 mixer
	E8363C, E8364C	E8364-20126		
W81	E8362C	E8362-20024	1	A36 step attenuator to port 1 SOURCE OUT
	E8363C, E8364C	E8364-20053		
W82	E8362C	E8362-20025	1	A37 step attenuator to port 2 SOURCE OUT
	E8363C, E8364C	E8364-20054		
W83	E8362C	E8362-20012	1	Port 1 CPLR THRU to A38 bias tee
	E8363C, E8364C	E8364-20039		
W84	E8362C	E8362-20013	1	Port 2 CPLR THRU to A39 bias tee
	E8363C, E8364C	E8364-20040		

**Figure 6-19 Bottom Semi-Rigid Cables, Options UNL/014/016 and UNL/014/016/080**

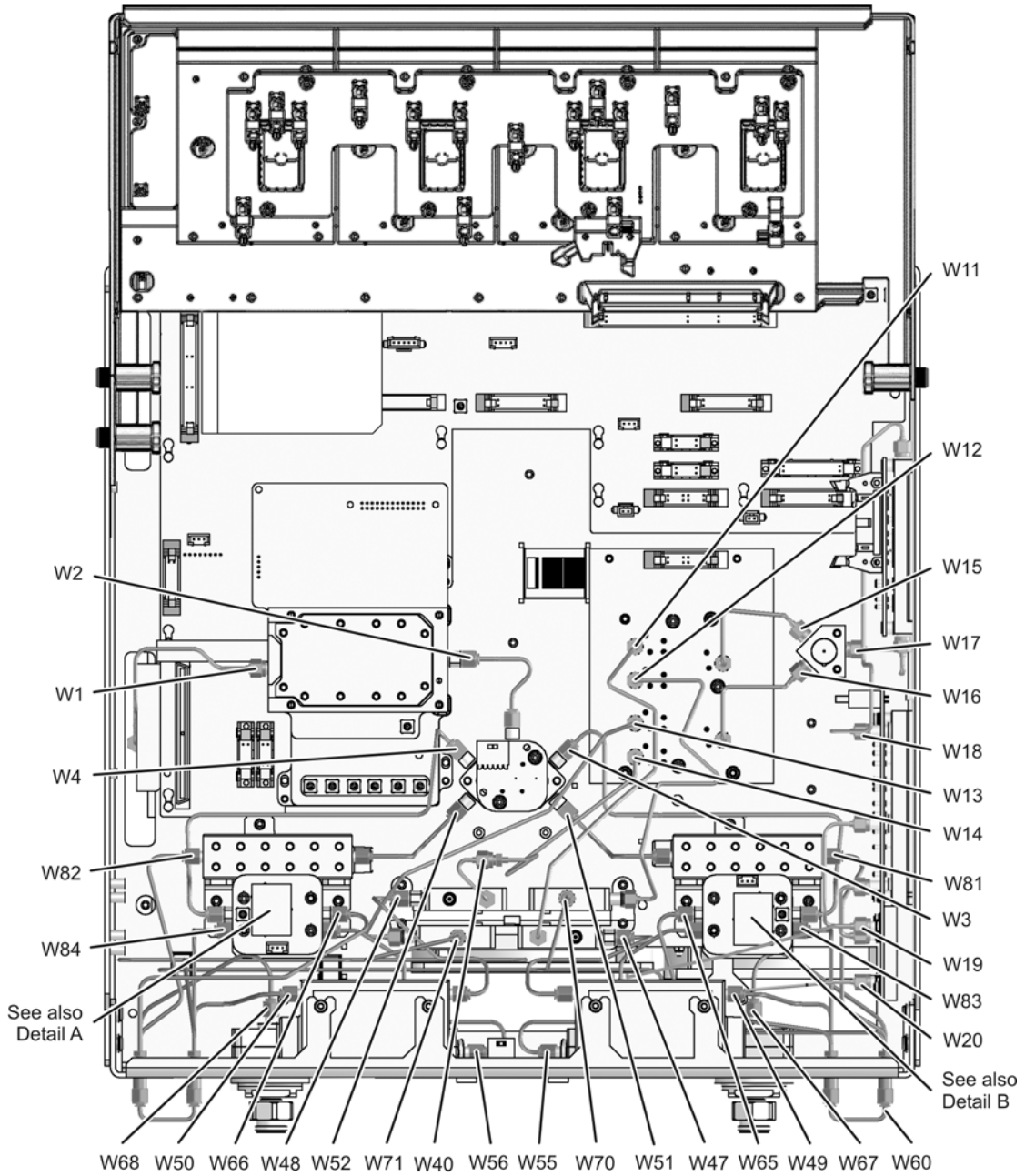

**Detail A (E8362C)**

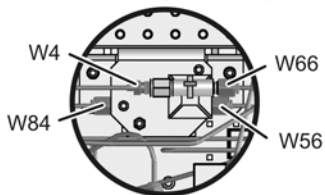

**Detail B (E8362C)**

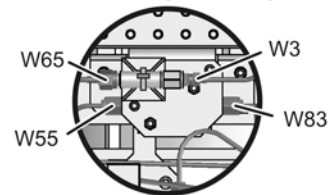

st579cblb\_new

### Bottom Assemblies, Options 014/080/081

Ref. Desig.	Models	Part Number <sup>a</sup>	Qty	Description
A16	All	E8364-60138	1	Test set motherboard
A17	All	5087-7127 <i>5087-6127</i>	1	LOMA 10
A18	All	5087-7128 <i>5087-6128</i>	1	MA 20
A19	All	5087-7139	1	Splitter
A20	All	5087-7129 <i>5087-6129</i>	1	LODA
A21	E8363C, E8364C	5087-7130 <i>5087-6130</i>	1	SOMA 50
A22	All	5087-7132 <i>5087-6132</i>	1	Switch splitter
A23	E8363C, E8364C	5087-7242	1	Channel R1 detector
A24	E8363C, E8364C	5087-7133	2	Channel R2 detector
A25 A26	E8362C	5086-7968	2	Test port 1 coupler Test port 2 coupler
	E8363C, E8364C	5086-7518	2	Test port 1 coupler Test port 2 coupler
A27 A30	All	5087-7122 <i>5087-6122</i>	2	Channel A first converter (mixer) Channel B first converter (mixer)
A28 A29		5087-7145 <i>5087-6145</i>	2	Channel R1 first converter (mixer) Channel R2 first converter (mixer)
A31 A32 A33 A34	All	E8364-60134	4	Channel A receiver module Channel R1 receiver module Channel R2 receiver module Channel B receiver module
A35	All	E8364-60135	1	Receiver motherboard
A41	All	Hard disk drive assembly. Refer to <a href="#">“Hard Disk Drive Assembly, All Options”</a> on page 6-80.		
A45 A46	All	5087-7238	2	50 GHz reference transfer switch
A49	All	E8361-60043	1	IF multiplexer board
①	E8362C	08493-60017	2	30-dB fixed attenuator (pad)

a. Part numbers in *italic* typeface are for rebuilt exchange assemblies. Refer to [“Rebuilt-Exchange Assemblies”](#) on page 6-5.



**Figure 6-20 Bottom Assemblies, Options 014/080/081**

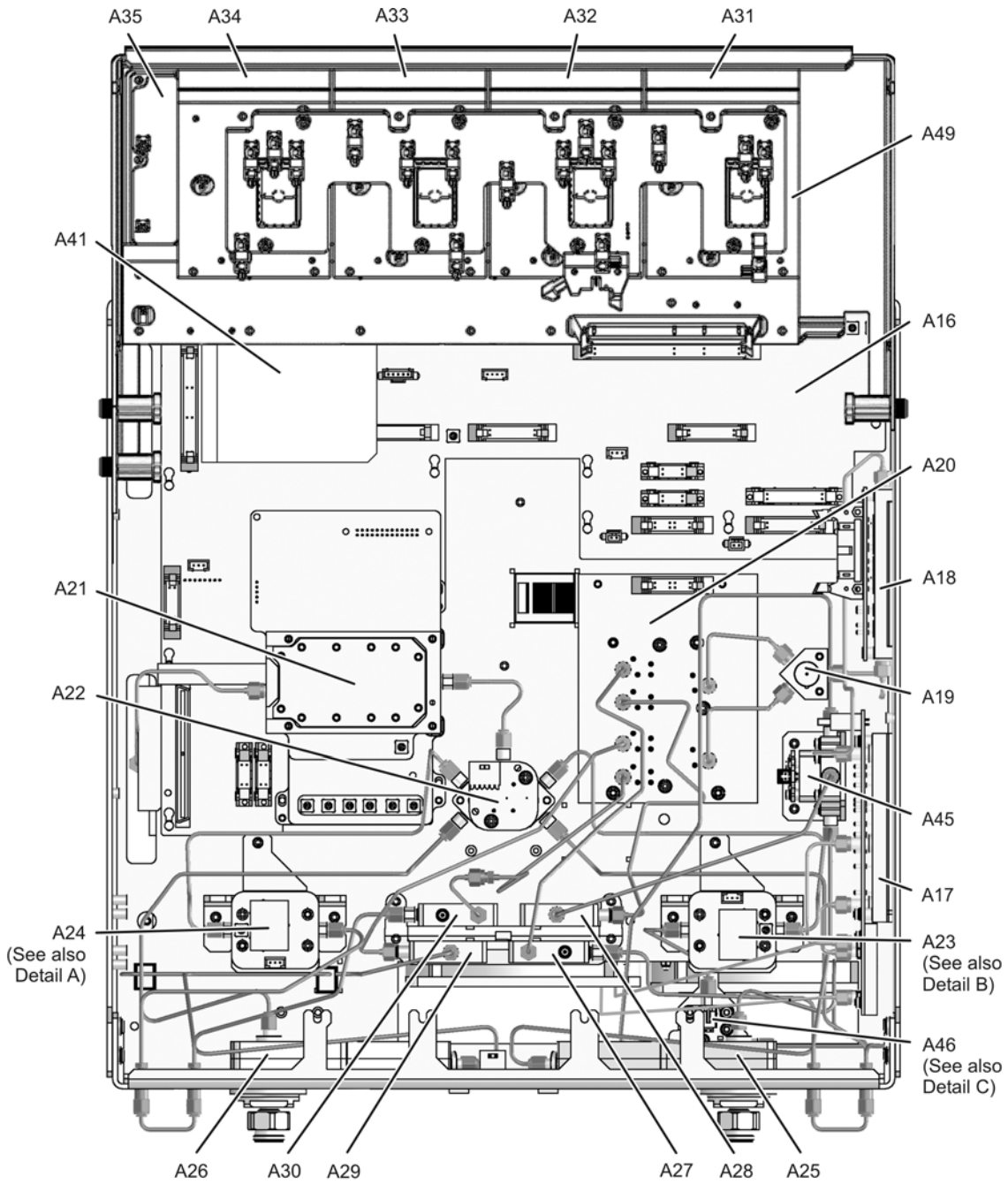

**Detail A (E8362C)**

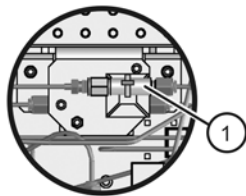

**Detail C**

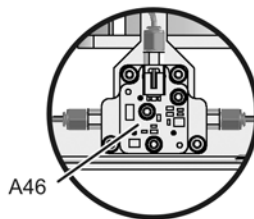

**Detail B (E8362C)**

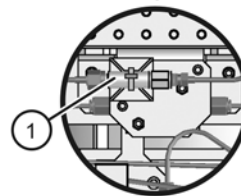

st580b\_new

**Bottom Semi-Rigid Cables, Options 014/080/081**

Ref. Desig.	Models	Part Number	Qty	Description
W1	E8362C	E8362-20002	1	A12 source 20 to A22 switch splitter
	E8363C, E8364C	E8364-20036		A12 source 20 to A21 SOMA 50
W2	E8363C, E8364C	E8364-20034	1	A21 SOMA 50 to A22 switch splitter
W3	E8362C	E8362-20003	1	A22 switch splitter to channel R1 30-dB attenuator
	E8363C, E8364C	E8364-20144		A22 switch splitter to A23 detector
W4	E8362C	E8362-20004	1	A22 switch splitter to channel R2 30-dB attenuator
	E8363C, E8364C	E8364-20024		A22 switch splitter to A24 detector
W11	All	E8364-20171	1	A20 LODA to A27 channel A mixer
W12	All	E8364-20172	1	A20 LODA to A28 channel R1 mixer
W13	All	E8364-20173	1	A20 LODA to A29 channel R2 mixer
W14	All	E8364-20146	1	A20 LODA to W40 (to A30 channel B mixer)
W15	All	E8364-20041	1	A19 splitter to A20 LODA
W16	All	E8364-20042	1	A19 splitter to A20 LODA
W17	All	E8364-20029	1	A18 MA 20 to A19 splitter
W18	All	E8364-20145	1	A17 LOMA 10 to A18 MA 20
W19-W20	All	Refer to "Top Cables–All, All Options Except 080" on page 6-16.		
W40	All	E8364-20032	1	W14 (from A20 LODA) to A30 channel B mixer
W60	E8362C	08720-20098	6	Front-panel jumper
	E8363C, E8364C	E8364-20059		
W61	E8362C	E8362-20016	1	A22 switch splitter to port 1 SOURCE OUT
	E8363C, E8364C	E8364-20081		
W62	E8362C	E8362-20017	1	A22 switch splitter to port 2 SOURCE OUT
	E8363C, E8364C	E8364-20082		
W63	E8362C	E8362-20018	1	Port 1 CPLR THRU to A25 test port 1 coupler
	E8363C, E8364C	E8364-20073		
W64	E8362C	E8362-20019	1	Port 2 CPLR THRU to A26 test port 2 coupler
	E8363C, E8364C	E8364-20074		
W65	E8362C	E8362-20007	1	Channel R1 attenuator to channel R1 SOURCE OUT
	E8363C, E8364C	E8364-20047		A23 detector to channel R1 SOURCE OUT
W66	E8362C	E8362-20053	1	Channel R2 attenuator to channel R2 SOURCE OUT
	E8363C, E8364C	E8364-20048		A24 detector to channel R2 SOURCE OUT
W67	E8362C	E8362-20020	1	A25 test port 1 coupler to Port 1 CPLR ARM
	E8363C, E8364C	E8364-20043		
W68	E8362C	E8362-20021	1	A26 test port 2 coupler to Port 2 CPLR ARM
	E8363C, E8364C	E8364-20044		
W69	E8362C	E8362-20022	1	A IN to A27 channel A mixer
	E8363C, E8364C	E8364-20045		
W70	E8362C	E8362-20029	1	R1 IN to A28 channel R1 mixer
	E8363C, E8364C	E8364-20075		
W71	E8362C	E8362-20030	1	R2 IN to A29 channel R2 mixer
	E8363C, E8364C	E8364-20076		
W72	E8362C	E8362-20023	1	B IN to A30 channel B mixer
	E8363C, E8364C	E8364-20046		
W95	E8362C	E8362-20032	1	A46 reference switch to channel R1 attenuator
	E8363C, E8364C	E8364-20119	1	A46 reference switch to A23 detector
W96	All	E8364-20127	1	A45 reference switch to A46 reference switch
W97	E8362C	E8362-20033	1	A46 reference switch to REF SOURCE OUT
	E8363C, E8364C	E8364-20121		
W98	E8362C	E8362-20034	1	A45 reference switch to REF R1 IN
	E8363C, E8364C	E8364-20123		
W99	E8362C	E8362-20043	1	A45 reference switch to A28 R1 mixer
	E8363C, E8364C	E8364-20152		

**Figure 6-21 Bottom Semi-Rigid Cables, Options 014/080/081**

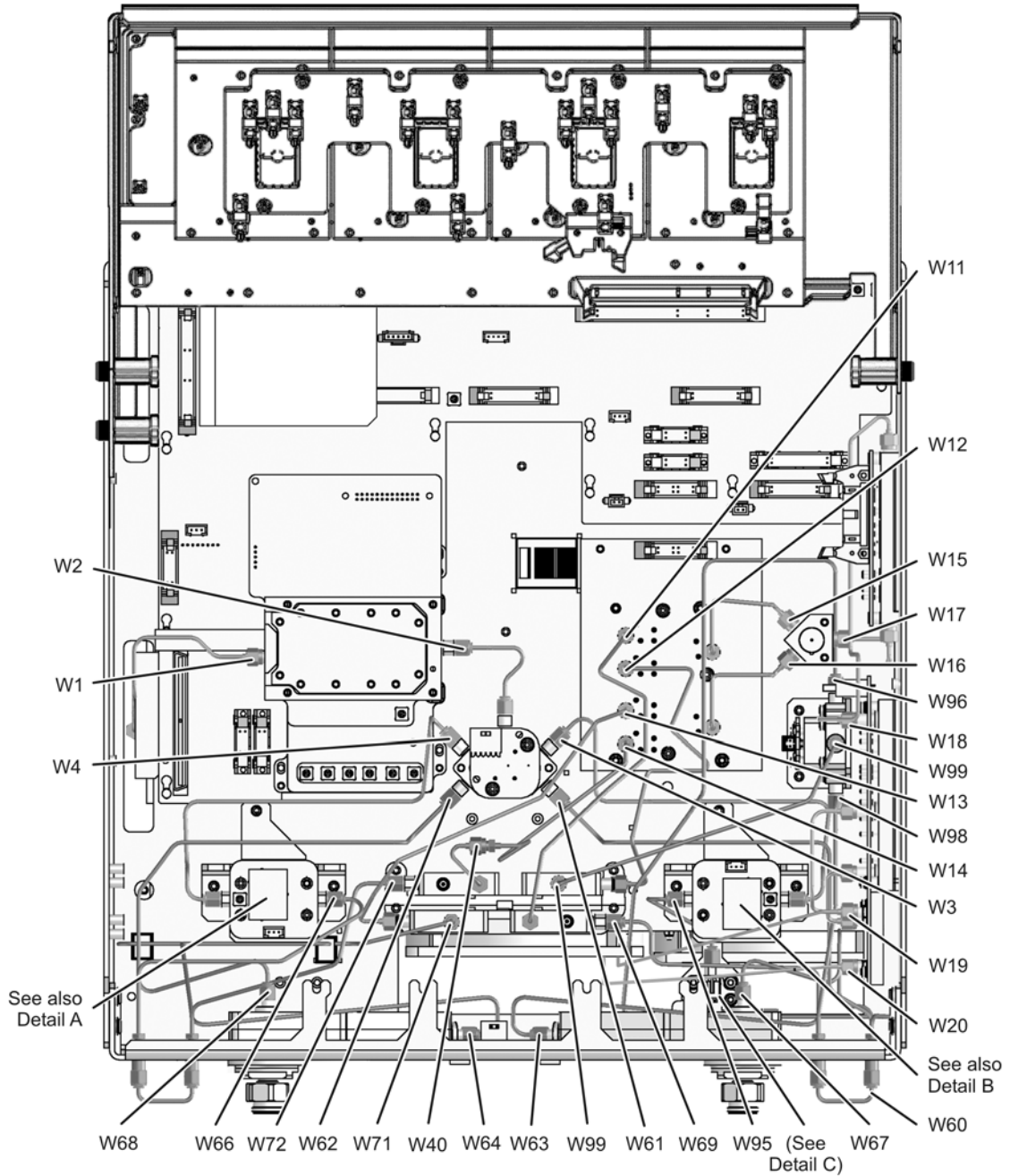

**Detail A (E8362C)**

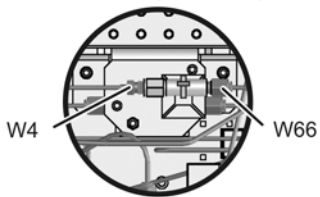

**Detail C**

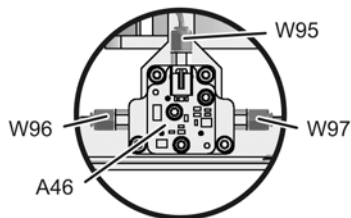

**Detail B (E8362C)**

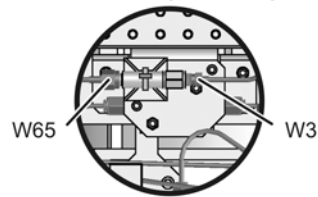

st580cblb\_new

**Bottom Assemblies, Options UNL/014/080/081**

Ref. Desig.	Models	Part Number <sup>a</sup>	Qty	Description
A16	All	E8364-60138	1	Test set motherboard
A17	All	5087-7127 <i>5087-6127</i>	1	LOMA 10
A18	All	5087-7128 <i>5087-6128</i>	1	MA 20
A19	All	5087-7139	1	Splitter
A20	All	5087-7129 <i>5087-6129</i>	1	LODA
A21	E8363C, E8364C	5087-7130 <i>5087-6130</i>	1	SOMA 50
A22	All	5087-7132 <i>5087-6132</i>	1	Switch splitter
A23	E8363C, E8364C	5087-7242	1	Channel R1 detector
A24	E8363C, E8364C	5087-7133	2	Channel R2 detector
A25 A26	E8362C	5086-7968	2	Test port 1 coupler Test port 2 coupler
	E8363C, E8364C	5086-7518	2	Test port 1 coupler Test port 2 coupler
A27 A30	All	5087-7122 <i>5087-6122</i>	2	Channel A first converter (mixer) Channel B first converter (mixer)
		5087-7145 <i>5087-6145</i>	2	Channel R1 first converter (mixer) Channel R2 first converter (mixer)
A28 A29				
A31 A32 A33 A34	All	E8364-60134	4	Channel A receiver module Channel R1 receiver module Channel R2 receiver module Channel B receiver module
A35	All	E8364-60135	1	Receiver motherboard
A36 A37	All	33325-60004	2	Step attenuator, 60-dB, port 1 (source) Step attenuator, 60-dB, port 2 (source)
A38 A39	E8362C	5086-7239	2	Bias tee with cable, port 1 Bias tee with cable, port 2
	E8363C, E8364C	5087-7233	2	Bias tee with cable, port 1 Bias tee with cable, port 2
A41	All	Hard disk drive assembly. Refer to <a href="#">“Hard Disk Drive Assembly, All Options”</a> on page 6-80.		
A45 A46	All	5087-7238	2	50 GHz reference transfer switch
A49	All	E8361-60043	1	IF multiplexer board

a. Part numbers in *italic* typeface are for rebuilt exchange assemblies. Refer to [“Rebuilt-Exchange Assemblies”](#) on page 6-5.

**Figure 6-22 Bottom Assemblies, Options UNL/014/080/081**

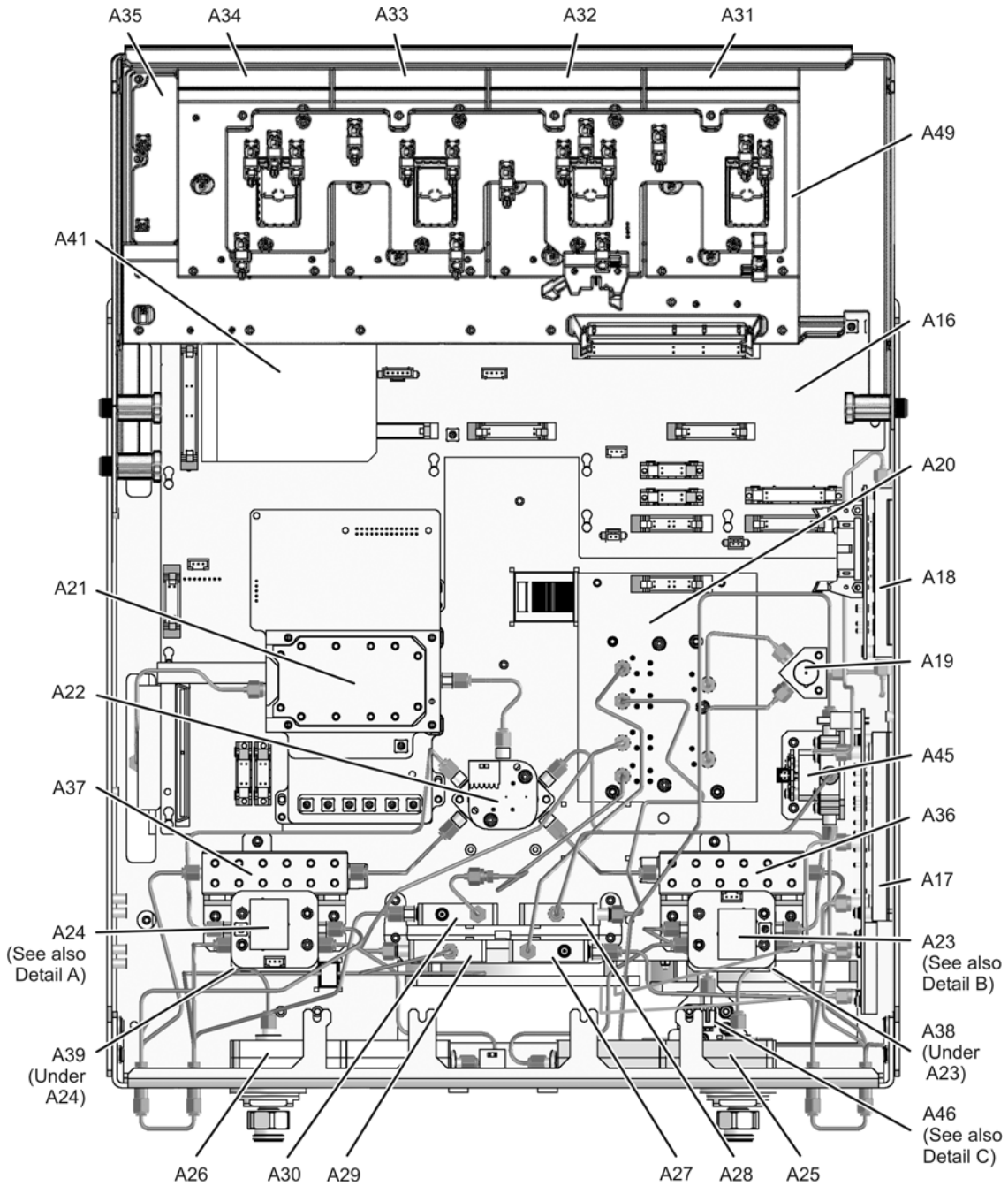

**Detail A (E8362C)**

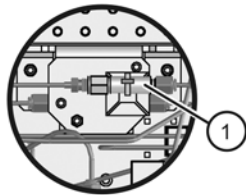

**Detail C**

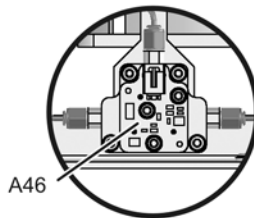

**Detail B (E8362C)**

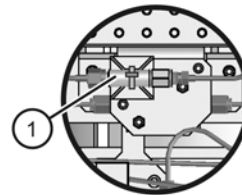

st581b\_new

**Bottom Semi-Rigid Cables, Options UNL/014/080/081**

Ref. Desig.	Models	Part Number	Qty	Description
W1	E8362C	E8362-20002	1	A12 source 20 to A22 switch splitter
	E8363C, E8364C	E8364-20036		A12 source 20 to A21 SOMA 50
W2	E8363C, E8364C	E8364-20034	1	A21 SOMA 50 to A22 switch splitter
W3	E8362C	E8362-20003	1	A22 switch splitter to channel R1 30-dB attenuator
	E8363C, E8364C	E8364-20144		A22 switch splitter to A23 detector
W4	E8362C	E8362-20004	1	A22 switch splitter to channel R2 30-dB attenuator
	E8363C, E8364C	E8364-20024		A22 switch splitter to A24 detector
W11	All	E8364-20171	1	A20 LODA to A27 channel A mixer
W12	All	E8364-20172	1	A20 LODA to A28 channel R1 mixer
W13	All	E8364-20173	1	A20 LODA to A29 channel R2 mixer
W14	All	E8364-20146	1	A20 LODA to W40 (to A30 channel B mixer)
W15	All	E8364-20041	1	A19 splitter to A20 LODA
W16	All	E8364-20042	1	A19 splitter to A20 LODA
W17	All	E8364-20029	1	A18 MA 20 to A19 splitter
W18	All	E8364-20145	1	A17 LOMA 10 to A18 MA 20
W19-W20	All	Refer to "Top Cables–All, All Options Except 080" on page 6-16.		
W40	All	E8364-20032	1	W14 (from A20 LODA) to A30 channel B mixer
W51	All	E8364-20055	1	A22 switch splitter to A36 step attenuator
W52	All	E8364-20056	1	A22 switch splitter to A37 step attenuator
W55	All	E8364-20167	1	A38 bias tee to A25 test port 1 coupler
W56	All	E8364-20168	1	A39 bias tee to A26 test port 2 coupler
W60	E8362C	08720-20098	6	Front-panel jumper
	E8363C, E8364C	E8364-20059		
W66	E8362C	E8362-20053	1	Channel R2 attenuator to channel R2 SOURCE OUT
	E8363C, E8364C	E8364-20048	1	A24 detector to channel R2 SOURCE OUT
W67	E8362C	E8362-20020	1	A25 test port 1 coupler to Port 1 CPLR ARM
	E8363C, E8364C	E8364-20043		
W68	E8362C	E8362-20021	1	A26 test port 2 coupler to Port 2 CPLR ARM
	E8363C, E8364C	E8364-20044		
W69	E8362C	E8362-20022	1	A IN to A27 channel A mixer
	E8363C, E8364C	E8364-20045		
W71	E8362C	E8362-20046	1	R2 IN to A29 channel R2 mixer
	E8363C, E8364C	E8364-20155		
W72	E8362C	E8362-20023	1	B IN to A30 channel B mixer
	E8363C, E8364C	E8364-20046		
W81	E8362C	E8362-20024	1	A36 step attenuator to port 1 SOURCE OUT
	E8363C, E8364C	E8364-20053		
W82	E8362C	E8362-20025	1	A37 step attenuator to port 2 SOURCE OUT
	E8363C, E8364C	E8364-20054		
W83	E8362C	E8362-20012	1	Port 1 CPLR THRU to A38 bias tee
	E8363C, E8364C	E8364-20039		
W84	E8362C	E8362-20013	1	Port 2 CPLR THRU to A39 bias tee
	E8363C, E8364C	E8364-20040		
W95	E8362C	E8362-20032	1	A46 reference switch to channel R1 attenuator
	E8363C, E8364C	E8364-20119	1	A46 reference switch to A23 detector
W96	All	E8364-20127	1	A45 reference switch to A46 reference switch
W97	E8362C	E8362-20033	1	A46 reference switch to REF SOURCE OUT
	E8363C, E8364C	E8364-20121		
W98	E8362C	E8362-20034	1	A45 reference switch to REF R1 IN
	E8363C, E8364C	E8364-20123		
W99	E8362C	E8362-20045	1	A45 reference switch to A28 R1 mixer
	E8363C, E8364C	E8364-20154		

Figure 6-23 Bottom Semi-Rigid Cables, Options UNL/014/080/081

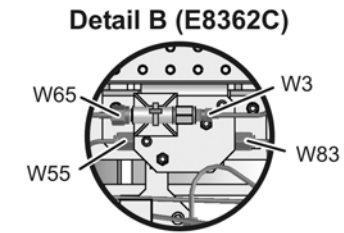
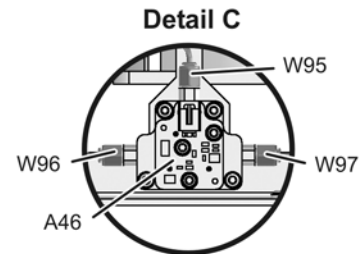
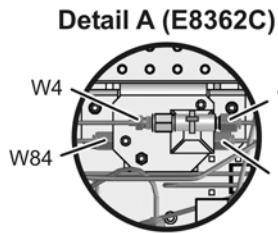
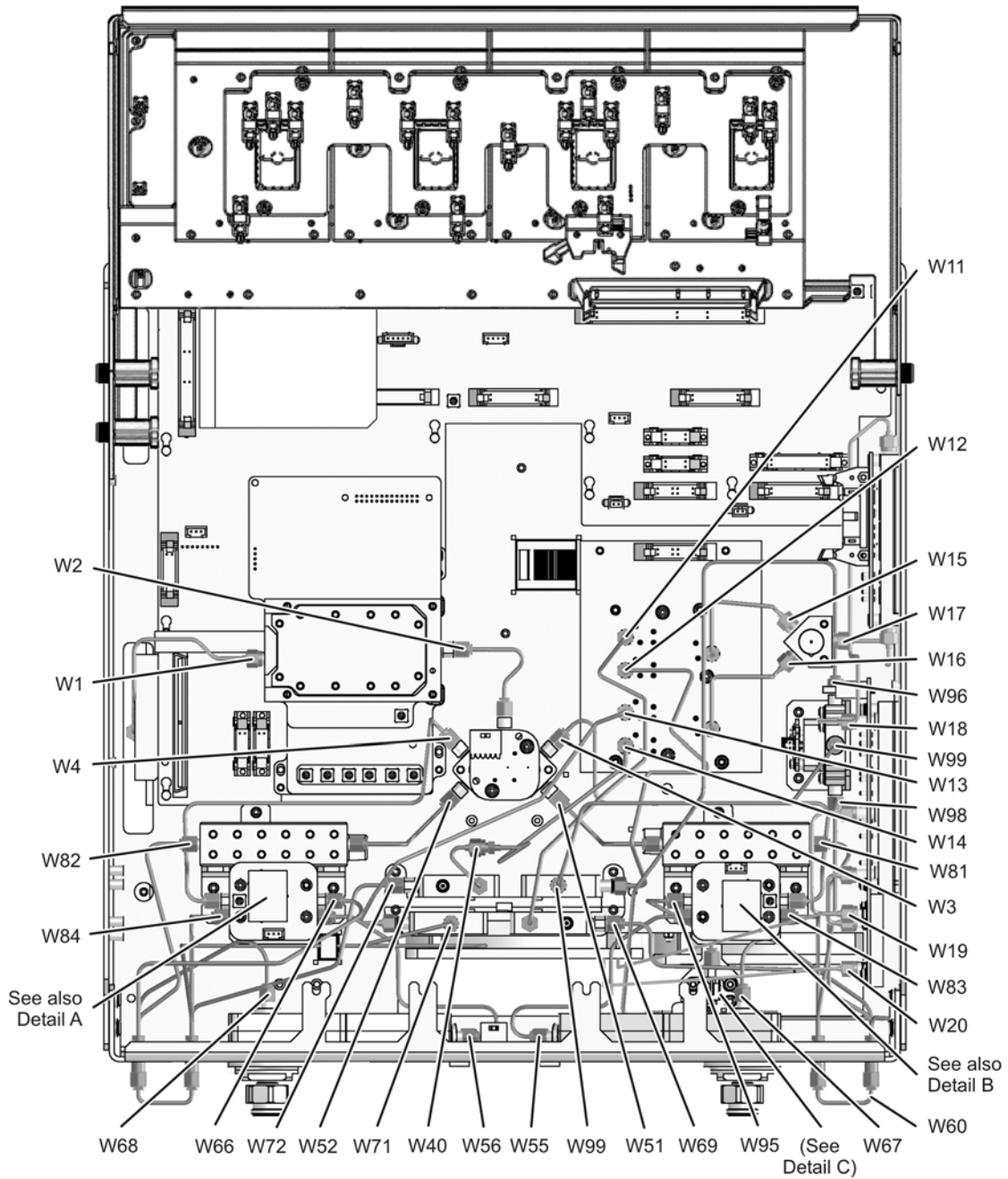

st581cblb\_new

**Bottom Assemblies, Options UNL/014/080/081/H11**

Ref. Desig.	Models	Part Number <sup>a</sup>	Qty	Description
A16	All	E8364-60138	1	Test set motherboard
A17	All	5087-7127 <i>5087-6127</i>	1	LOMA 10
A18	All	5087-7128 <i>5087-6128</i>	1	MA 20
A19	All	5087-7139	1	Splitter
A20	All	5087-7129 <i>5087-6129</i>	1	LODA
A21	E8363C, E8364C	5087-7130 <i>5087-6130</i>	1	SOMA 50
A22	All	5087-7132 <i>5087-6132</i>	1	Switch splitter
A23	E8363C, E8364C	5087-7242	1	Channel R1 detector
A24	E8363C, E8364C	5087-7133	2	Channel R2 detector
A25 A26	E8362C	5086-7968	2	Test port 1 coupler Test port 2 coupler
	E8363C, E8364C	5086-7518	2	Test port 1 coupler Test port 2 coupler
A27 A30	All	5087-7122 <i>5087-6122</i>	2	Channel A first converter (mixer) Channel B first converter (mixer)
		5087-7145 <i>5087-6145</i>	2	Channel R1 first converter (mixer) Channel R2 first converter (mixer)
A28 A29				
A31 A32 A33 A34	All	E8364-60134	4	Channel A receiver module Channel R1 receiver module Channel R2 receiver module Channel B receiver module
A35	All	E8364-60135	1	Receiver motherboard
A36 A37	All	33325-60004	2	Step attenuator, 60-dB, port 1 (source) Step attenuator, 60-dB, port 2 (source)
A38 A39	E8362C	5086-7239	2	Bias tee with cable, port 1 Bias tee with cable, port 2
	E8363C, E8364C	5087-7233	2	Bias tee with cable, port 1 Bias tee with cable, port 2
A41	All	Hard disk drive assembly. Refer to <a href="#">“Hard Disk Drive Assembly, All Options”</a> on page 6-80.		
A45 A46	All	5087-7238	2	50 GHz reference transfer switch
A47 A48	All	0955-0148	1	Coupler, RF path
				Coupler, LO path
A49	All	E8361-60043	1	IF multiplexer board

a. Part numbers in *italic* typeface are for rebuilt exchange assemblies. Refer to [“Rebuilt-Exchange Assemblies”](#) on page 6-5.



**Figure 6-24 Bottom Assemblies, Options UNL/014/080/081/H11**

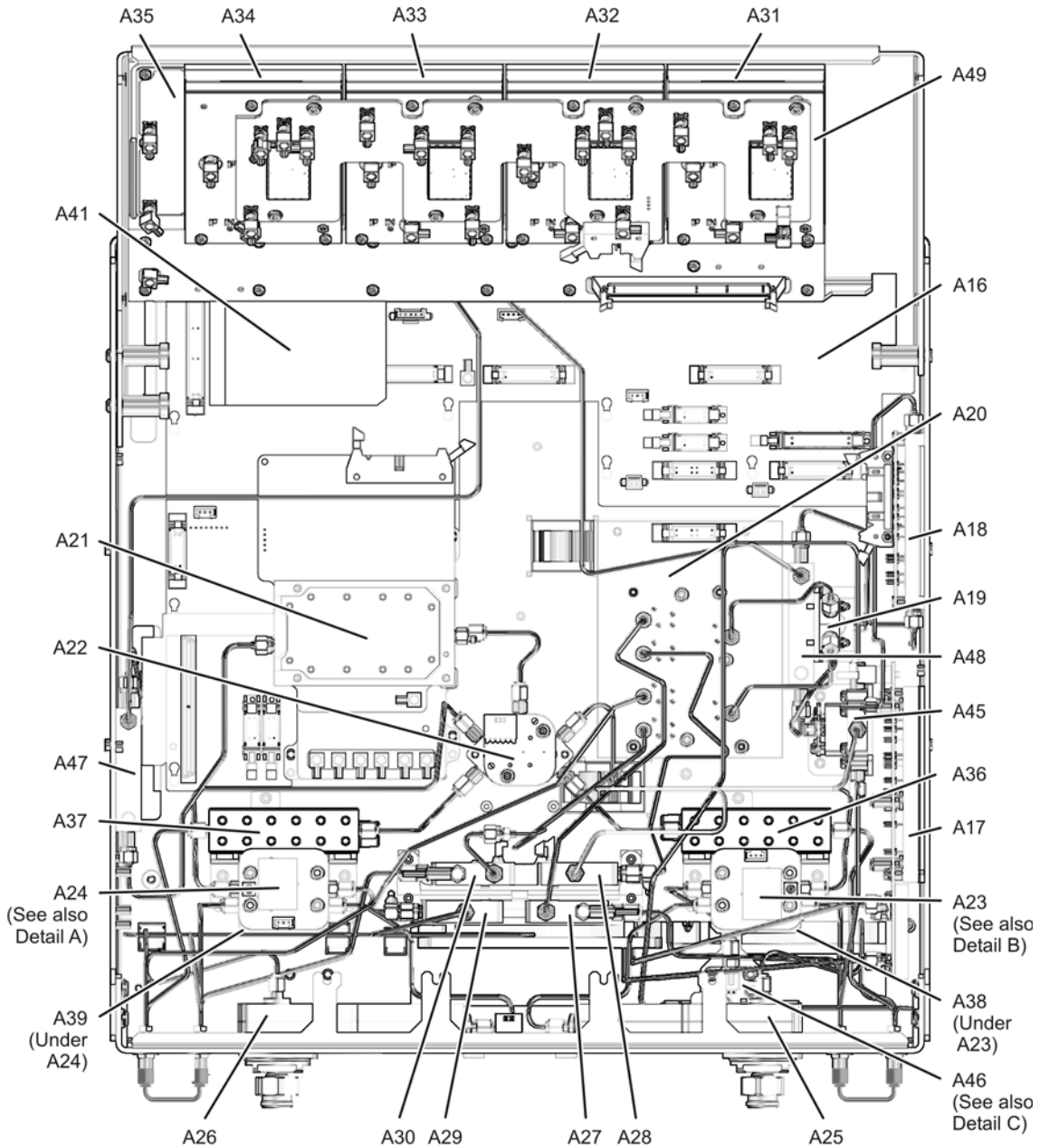

**Detail A (E8362C)**

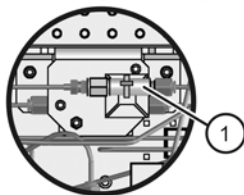

**Detail C**

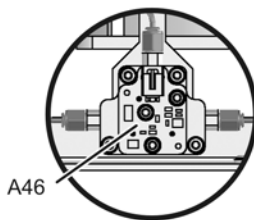

**Detail B (E8362C)**

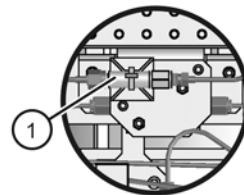

st593b\_new

### Bottom Semi-Rigid Cables, Options UNL/014/080/081/H11

Ref. Desig.	Models	Part Number	Qty	Description
W2	E8363C, E8364C	E8364-20034	1	A21 SOMA 50 to A22 switch splitter
W3	E8362C	E8362-20003	1	A22 switch splitter to channel R1 30-dB attenuator
	E8363C, E8364C	E8364-20144		A22 switch splitter to A23 detector
W4	E8362C	E8362-20004	1	A22 switch splitter to channel R2 30-dB attenuator
	E8363C, E8364C	E8364-20024		A22 switch splitter to A24 detector
W11	All	E8364-20171	1	A20 LODA to A27 channel A mixer
W12	All	E8364-20172	1	A20 LODA to A28 channel R1 mixer
W13	All	E8364-20173	1	A20 LODA to A29 channel R2 mixer
W14	All	E8364-20146	1	A20 LODA to W40 (to A30 channel B mixer)
W15	All	E8361-20056	1	A19 splitter to A20 LODA
W16	All	E8361-20057	1	A19 splitter to A20 LODA
W18	All	E8364-20145	1	A17 LOMA 10 to A18 MA 20
W19-W20	All	Refer to "Top Cables--All, All Options Except 080" on page 6-16.		
W40	All	E8364-20032	1	W14 (from A20 LODA) to A30 channel B mixer
W51	All	E8364-20055	1	A22 switch splitter to A36 step attenuator
W52	All	E8364-20056	1	A22 switch splitter to A37 step attenuator
W55	All	E8364-20167	1	A38 bias tee to A25 test port 1 coupler
W56	All	E8364-20168	1	A39 bias tee to A26 test port 2 coupler
W60	E8362C	08720-20098	6	Front-panel jumper
	E8363C, E8364C	E8364-20059		
W66	E8362C	E8362-20053	1	Channel R2 attenuator to channel R2 SOURCE OUT
	E8363C, E8364C	E8364-20048	1	A24 detector to channel R2 SOURCE OUT
W67	E8362C	E8362-20020	1	A25 test port 1 coupler to Port 1 CPLR ARM
	E8363C, E8364C	E8364-20043		
W68	E8362C	E8362-20021	1	A26 test port 2 coupler to Port 2 CPLR ARM
	E8363C, E8364C	E8364-20044		
W69	E8362C	E8362-20022	1	A IN to A27 channel A mixer
	E8363C, E8364C	E8364-20045		
W71	E8362C	E8362-20046	1	R2 IN to A29 channel R2 mixer
	E8363C, E8364C	E8364-20155		
W72	E8362C	E8362-20023	1	B IN to A30 channel B mixer
	E8363C, E8364C	E8364-20046		
W81	E8362C	E8362-20024	1	A36 step attenuator to port 1 SOURCE OUT
	E8363C, E8364C	E8364-20053		
W82	E8362C	E8362-20025	1	A37 step attenuator to port 2 SOURCE OUT
	E8363C, E8364C	E8364-20054		
W83	E8362C	E8362-20012	1	Port 1 CPLR THRU to A38 bias tee
	E8363C, E8364C	E8364-20039		
W84	E8362C	E8362-20013	1	Port 2 CPLR THRU to A39 bias tee
	E8363C, E8364C	E8364-20040		
W95	E8362C	E8362-20032	1	A46 reference switch to channel R1 attenuator
	E8363C, E8364C	E8364-20119	1	A46 reference switch to A23 detector
W96	All	E8364-20127	1	A45 reference switch to A46 reference switch
W97	E8362C	E8362-20033	1	A46 reference switch to REF SOURCE OUT
	E8363C, E8364C	E8364-20121		
W98	E8362C	E8362-20034	1	A45 reference switch to REF R1 IN
	E8363C, E8364C	E8364-20123		
W99	E8362C	E8362-20045	1	A45 reference switch to A28 R1 mixer
	E8363C, E8364C	E8364-20154		
W109	All	E8361-20050	1	A12 source to A47 RF coupler
W110	All	E8361-20053	1	A18 MA 24 to A48 LO coupler
W111	E8362C	E8362-20055	1	A47 RF coupler to A22 switch
	E8363C, E8364C	E8361-20051		A47 RF coupler to A21 SOMA 50
W112	All	E8361-20055	1	A48 LO coupler to A19 splitter
W113	All	E8361-20052	1	A47 RF coupler to rear panel TEST SET DRIVERS RF
W114	All	E8361-20054	1	A48 LO coupler to rear panel TEST SET DRIVERS LO

**Figure 6-25 Bottom Semi-Rigid Cables, Options UNL/014/080/081/H11**

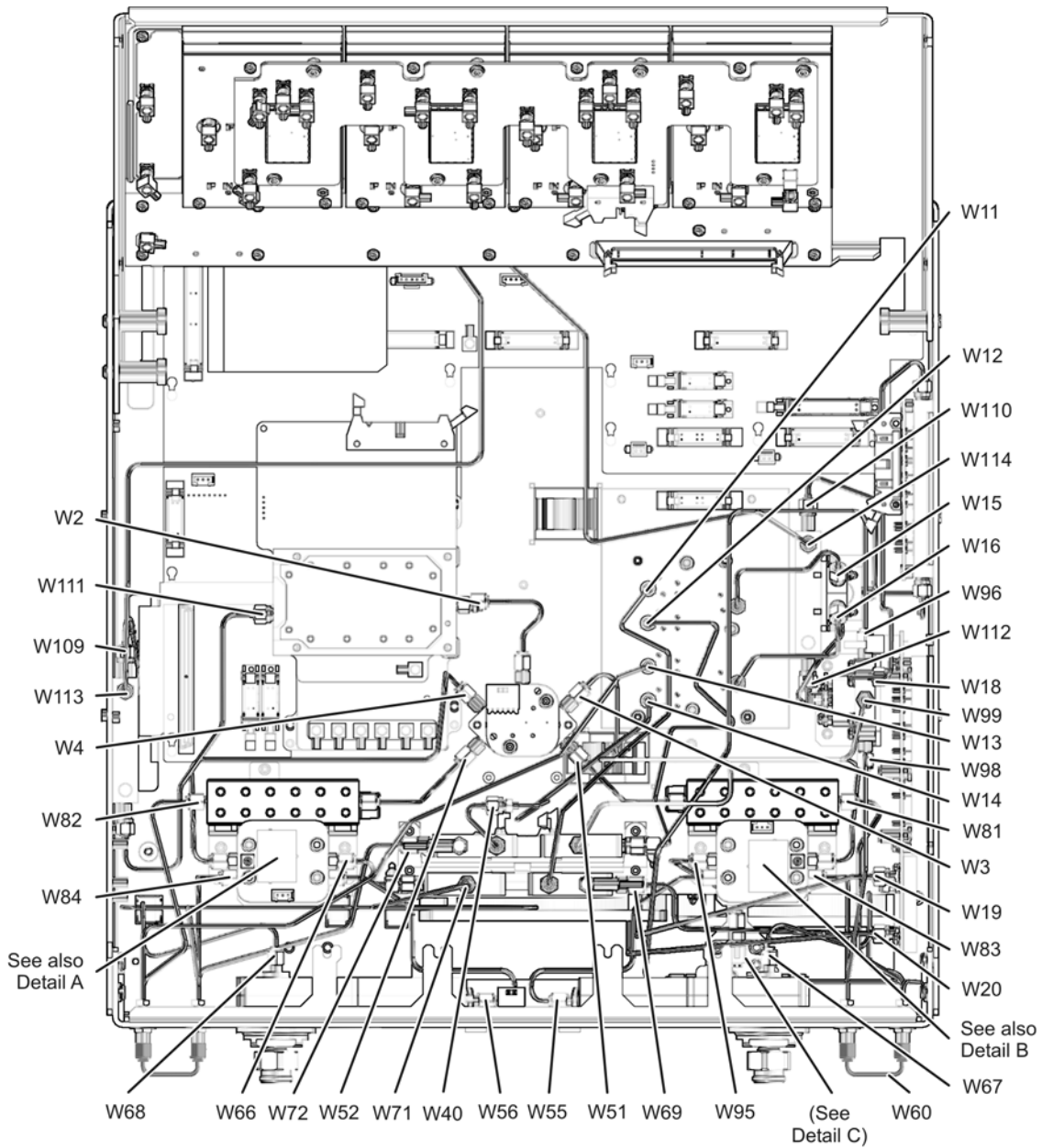

**Detail A (E8362C)**

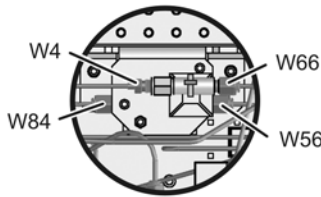

**Detail C**

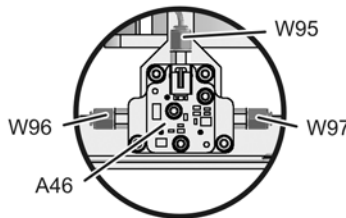

**Detail B (E8362C)**

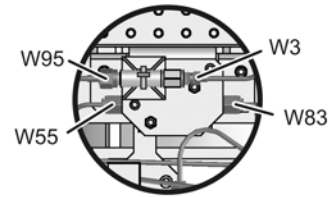

st593cblb\_new

**Bottom Assemblies, Options UNL/014/016/080/081**

Ref. Desig.	Models	Part Number <sup>a</sup>	Qty	Description
A16	All	E8364-60138	1	Test set motherboard
A17	All	5087-7127 <i>5087-6127</i>	1	LOMA 10
A18	All	5087-7128 <i>5087-6128</i>	1	MA 20
A19	All	5087-7139	1	Splitter
A20	All	5087-7129 <i>5087-6129</i>	1	LODA
A21	E8363C, E8364C	5087-7130 <i>5087-6130</i>	1	SOMA 50
A22	All	5087-7132 <i>5087-6132</i>	1	Switch splitter
A23	E8363C, E8364C	5087-7242	1	Channel R1 detector
A24	E8363C, E8364C	5087-7133	2	Channel R2 detector
A25 A26	E8362C	5086-7968	2	Test port 1 coupler Test port 2 coupler
	E8363C, E8364C	5086-7518	2	Test port 1 coupler Test port 2 coupler
A27 A30	All	5087-7122 <i>5087-6122</i>	2	Channel A first converter (mixer) Channel B first converter (mixer)
		5087-7145 <i>5087-6145</i>		
A28 A29		5087-7145 <i>5087-6145</i>	2	Channel R1 first converter (mixer) Channel R2 first converter (mixer)
A31 A32 A33 A34	All	E8364-60134	4	Channel A receiver module Channel R1 receiver module Channel R2 receiver module Channel B receiver module
A35	All	E8364-60135	1	Receiver motherboard
A36 A37	All	33325-60004	2	Step attenuator, 60-dB, port 1 (source) Step attenuator, 60-dB, port 2 (source)
A38 A39	E8362C	5086-7239	2	Bias tee with cable, port 1 Bias tee with cable, port 2
	E8363C, E8364C	5087-7233	2	Bias tee with cable, port 1 Bias tee with cable, port 2
A41	All	Hard disk drive assembly. Refer to <a href="#">“Hard Disk Drive Assembly, All Options” on page 6-80.</a>		
A43 A44	All	33325-60011	2	Step attenuator (receiver), 35-dB, port 1 Step attenuator (receiver), 35-dB, port 2
A45 A46	All	5087-7238	2	50 GHz reference transfer switch
A49	All	E8361-60043	1	IF multiplexer board

a. Part numbers in *italic* typeface are for rebuilt exchange assemblies. Refer to [“Rebuilt-Exchange Assemblies” on page 6-5.](#)

**Figure 6-26 Bottom Assemblies, Options UNL/014/016/080/081**

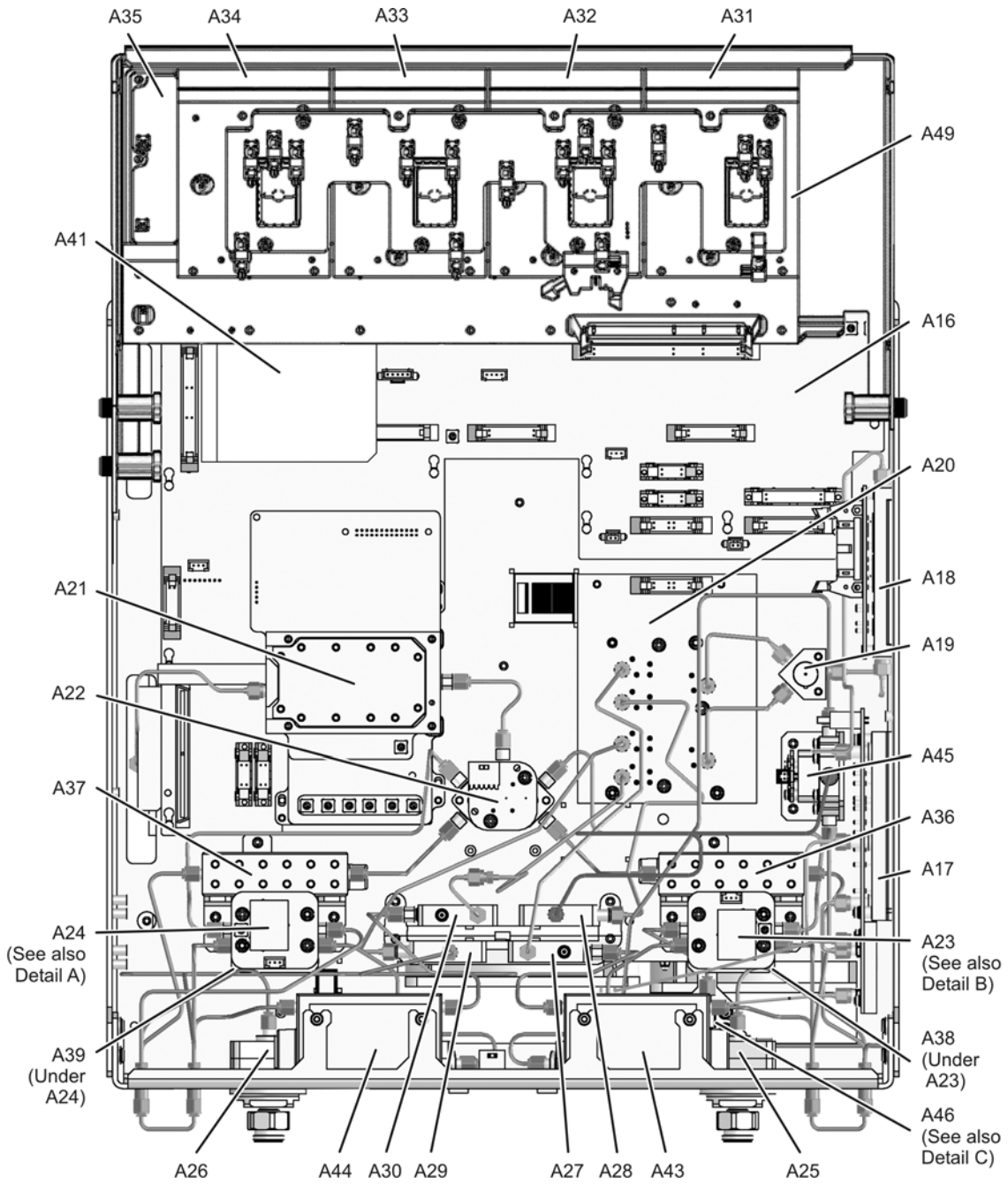

**Detail A (E8362C)**

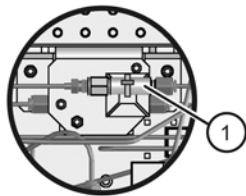

**Detail C**

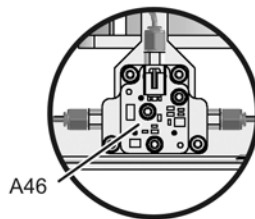

**Detail B (E8362C)**

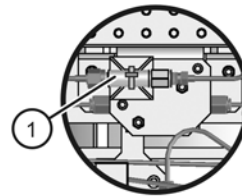

st582b\_new

**Bottom Semi-Rigid Cables, Options UNL/014/016/080/081**

Ref. Desig.	Models	Part Number	Qty	Description
W1	E8362C	E8362-20002	1	A12 source 20 to A22 switch splitter
	E8363C, E8364C	E8364-20036		A12 source 20 to A21 SOMA 50
W2	E8363C, E8364C	E8364-20034	1	A21 SOMA 50 to A22 switch splitter
W3	E8362C	E8362-20003	1	A22 switch splitter to channel R1 30-dB attenuator
	E8363C, E8364C	E8364-20144		A22 switch splitter to A23 detector
W4	E8362C	E8362-20004	1	A22 switch splitter to channel R2 30-dB attenuator
	E8363C, E8364C	E8364-20024		A22 switch splitter to A24 detector
W11	All	E8364-20171	1	A20 LODA to A27 channel A mixer
W12	All	E8364-20172	1	A20 LODA to A28 channel R1 mixer
W13	All	E8364-20173	1	A20 LODA to A29 channel R2 mixer
W14	All	E8364-20146	1	A20 LODA to W40 (to A30 channel B mixer)
W15	All	E8364-20041	1	A19 splitter to A20 LODA
W16	All	E8364-20042	1	A19 splitter to A20 LODA
W17	All	E8364-20029	1	A18 MA 20 to A19 splitter
W18	All	E8364-20145	1	A17 LOMA 10 to A18 MA 20
W19-W20	All	Refer to "Top Cables-All, All Options Except 080" on page 6-16.		
W40	All	E8364-20032	1	W14 (from A20 LODA) to A30 channel B mixer
W47	All	E8364-20131	1	A43 channel A step attenuator to A27 channel A mixer
W48	All	E8364-20132	1	A44 channel B step attenuator to A30 channel B mixer
W49	E8362C	E8362-20035	1	A IN to A43 channel A step attenuator
	E8363C, E8364C	E8364-20129		
W50	E8362C	E8362-20036	1	B IN to A44 channel B step attenuator
	E8363C, E8364C	E8364-20130		
W51	All	E8364-20055	1	A22 switch splitter to A36 step attenuator
W52	All	E8364-20056	1	A22 switch splitter to A37 step attenuator
W55	All	E8364-20167	1	A38 bias tee to A25 test port 1 coupler
W56	All	E8364-20168	1	A39 bias tee to A26 test port 2 coupler
W60	E8362C	08720-20098	6	Front-panel jumper
	E8363C, E8364C	E8364-20059		
W66	E8362C	E8362-20053	1	Channel R2 attenuator to channel R2 SOURCE OUT
	E8363C, E8364C	E8364-20048		A24 detector to channel R2 SOURCE OUT
W67	E8362C	E8362-20051	1	A25 test port 1 coupler to Port 1 CPLR ARM
	E8363C, E8364C	E8364-20156		
W68	E8362C	E8362-20052	1	A26 test port 2 coupler to Port 2 CPLR ARM
	E8363C, E8364C	E8364-20157		
W71	E8362C	E8362-20038	1	R2 IN to A29 channel R2 mixer
	E8363C, E8364C	E8364-20126		
W81	E8362C	E8362-20024	1	A36 step attenuator to port 1 SOURCE OUT
	E8363C, E8364C	E8364-20053		
W82	E8362C	E8362-20025	1	A37 step attenuator to port 2 SOURCE OUT
	E8363C, E8364C	E8364-20054		
W83	E8362C	E8362-20012	1	Port 1 CPLR THRU to A38 bias tee
	E8363C, E8364C	E8364-20039		
W84	E8362C	E8362-20013	1	Port 2 CPLR THRU to A39 bias tee
	E8363C, E8364C	E8364-20040		
W95	E8362C	E8362-20032	1	A46 reference switch to channel R1 attenuator
	E8363C, E8364C	E8364-20119		A46 reference switch to A23 detector
W96	AI	E8364-20127	1	A45 reference switch to A46 reference switch
W97	E8362C	E8362-20033	1	A46 reference switch to REF SOURCE OUT
	E8363C, E8364C	E8364-20121		
W98	E8362C	E8362-20034	1	A45 reference switch to REF R1 IN
	E8363C, E8364C	E8364-20123		
W99	E8362C	E8362-20037	1	A45 reference switch to A28 R1 mixer
	E8363C, E8364C	E8364-20125		

**Figure 6-27 Bottom Semi-Rigid Cables, Options UNL/014/016/080/081**

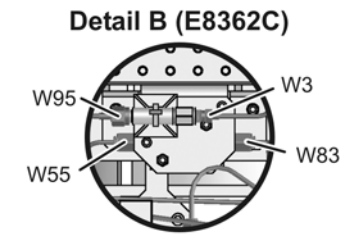
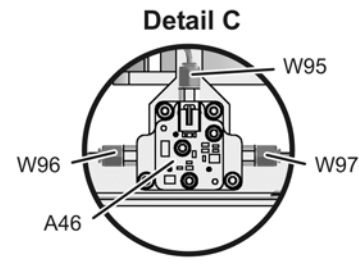
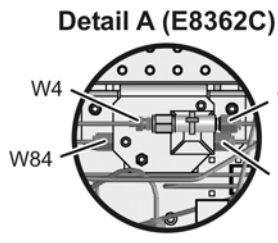
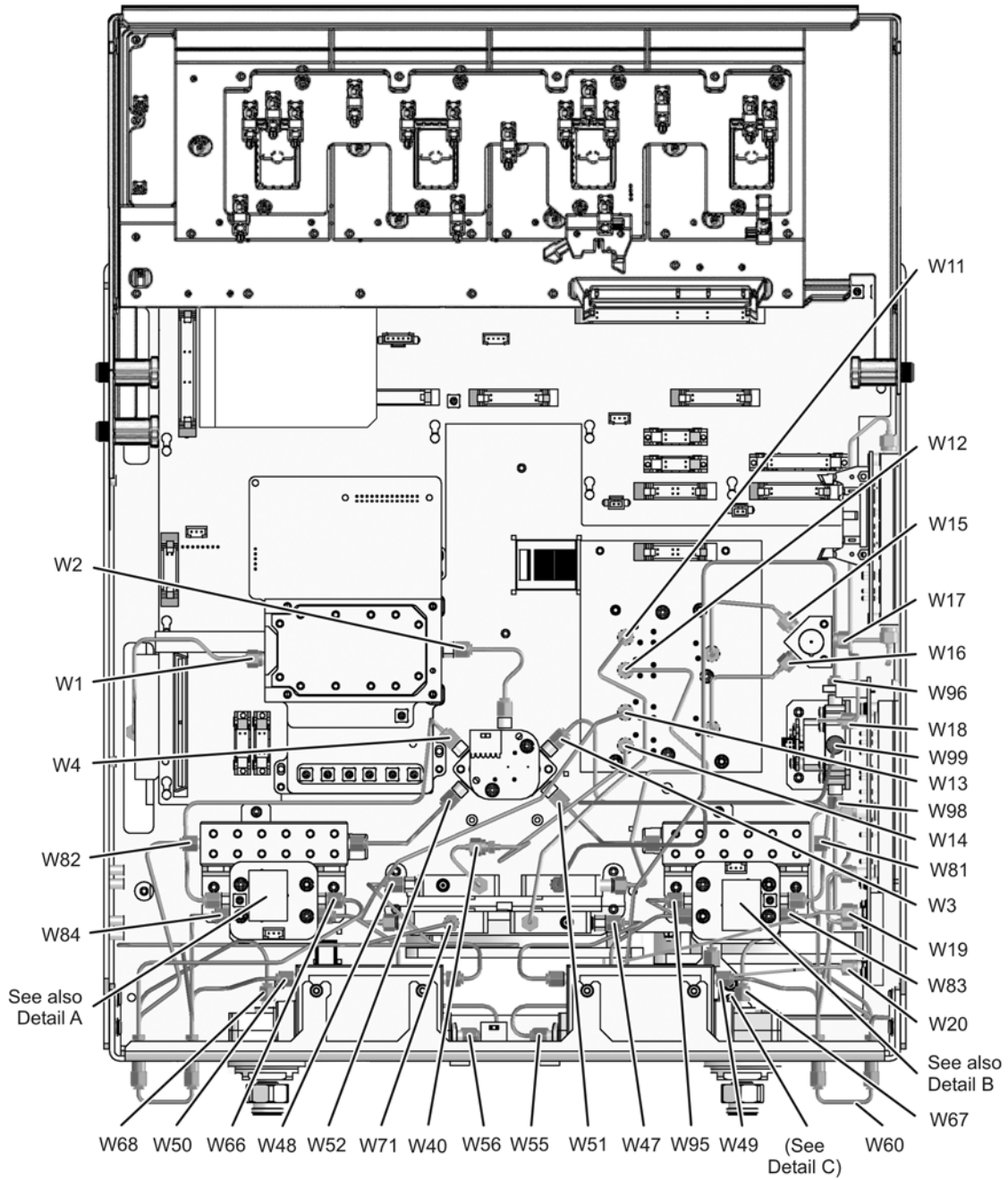

st582cblb\_new

**Bottom Assemblies, Options UNL/014/016/080/081/H11**

Ref. Desig.	Models	Part Number <sup>a</sup>	Qty	Description
A16	All	E8364-60138	1	Test set motherboard
A17	All	5087-7127 <i>5087-6127</i>	1	LOMA 10
A18	All	5087-7128 <i>5087-6128</i>	1	MA 20
A19	All	5087-7139	1	Splitter
A20	All	5087-7129 <i>5087-6129</i>	1	LODA
A21	E8363C, E8364C	5087-7130 <i>5087-6130</i>	1	SOMA 50
A22	All	5087-7132 <i>5087-6132</i>	1	Switch splitter
A23	E8363C, E8364C	5087-7242	1	Channel R1 detector
A24	E8363C, E8364C	5087-7133	2	Channel R2 detector
A25 A26	E8362C	5086-7968	2	Test port 1 coupler Test port 2 coupler
	E8363C, E8364C	5086-7518	2	Test port 1 coupler Test port 2 coupler
A27 A30	All	5087-7122 <i>5087-6122</i>	2	Channel A first converter (mixer) Channel B first converter (mixer)
		587-7145 <i>5087-6145</i>	2	Channel R1 first converter (mixer) Channel R2 first converter (mixer)
A28 A29				
A31 A32 A33 A34	All	E8364-60134	4	Channel A receiver module Channel R1 receiver module Channel R2 receiver module Channel B receiver module
A35	All	E8364-60135	1	Receiver motherboard
A36 A37	All	33325-60004	2	Step attenuator, 60-dB, port 1 (source) Step attenuator, 60-dB, port 2 (source)
A38 A39	E8362C	5086-7239	2	Bias tee with cable, port 1 Bias tee with cable, port 2
	E8363C, E8364C	5087-7233	2	Bias tee with cable, port 1 Bias tee with cable, port 2
A41	All	Hard disk drive assembly. Refer to "Hard Disk Drive Assembly, All Options" on page 6-80.		
A43 A44	All	33325-60011	2	Step attenuator (receiver), 35-dB, port 1 Step attenuator (receiver), 35-dB, port 2
A45 A46	All	5087-7238	2	50 GHz reference transfer switch
A47 A48	All	0955-0148	1	Coupler, RF path
				Coupler, LO path
A49	All	E8361-60043	1	IF multiplexer board

a. Part numbers in *italic* typeface are for rebuilt exchange assemblies. Refer to "Rebuilt-Exchange Assemblies" on page 6-5.



**Figure 6-28 Bottom Assemblies, Options UNL/014/016/080/081/H11**

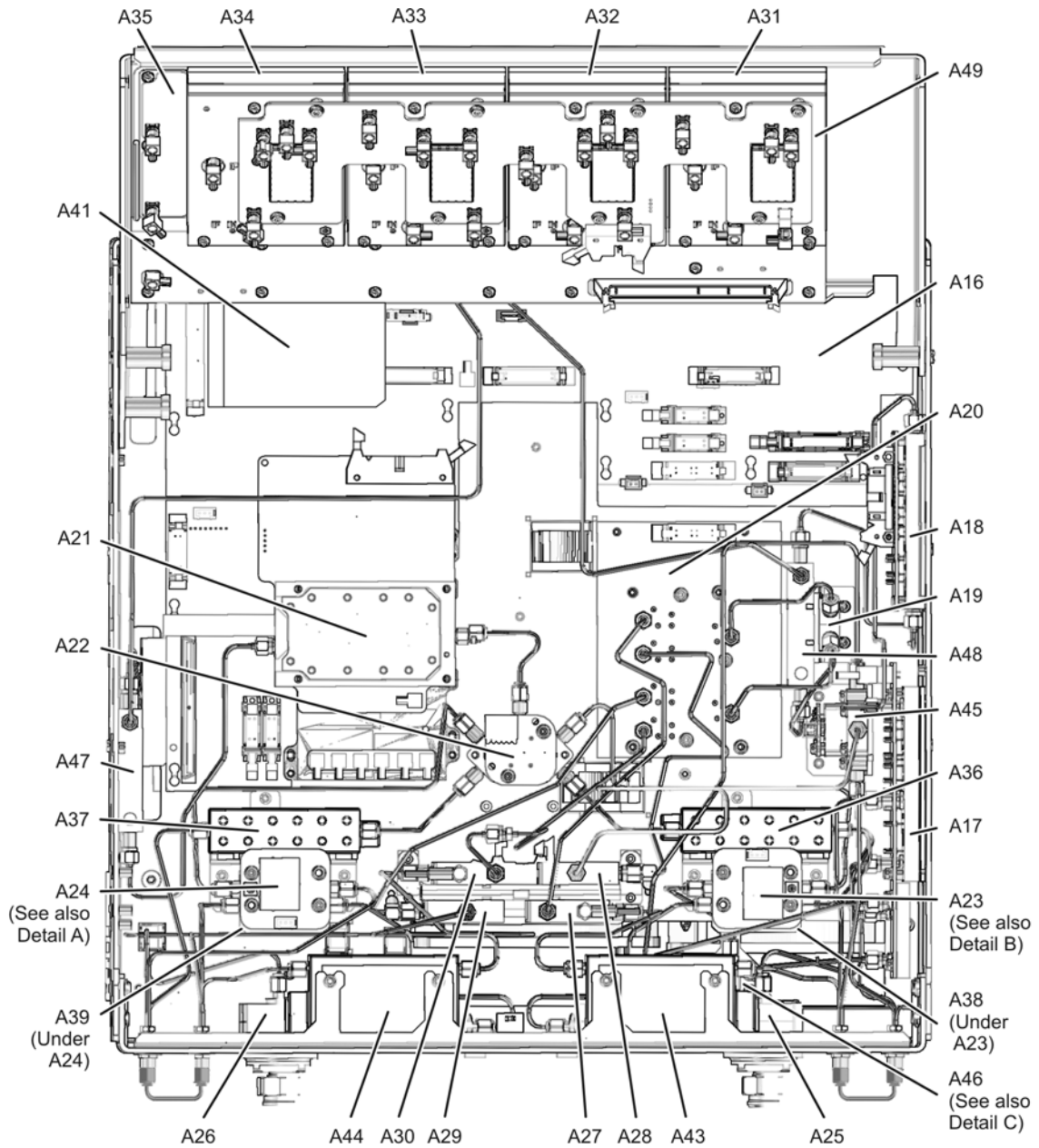

**Detail A (E8362C)**

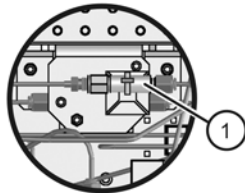

**Detail C**

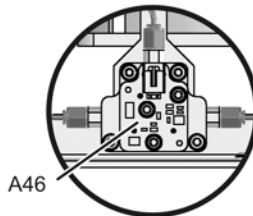

**Detail B (E8362C)**

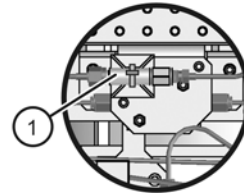

st594b\_new

**Bottom Semi-Rigid Cables, Options UNL/014/016/080/081/H11**

Ref. Desig.	Models	Part Number	Qty	Description
W2	E8363C, E8364C	E8364-20034	1	A21 SOMA 50 to A22 switch splitter
W3	E8362C	E8362-20003	1	A22 switch splitter to channel R1 30-dB attenuator
	E8363C, E8364C	E8364-20144		A22 switch splitter to A23 detector
W4	E8362C	E8362-20004	1	A22 switch splitter to channel R2 30-dB attenuator
	E8363C, E8364C	E8364-20024		A22 switch splitter to A24 detector
W11	All	E8364-20171	1	A20 LODA to A27 channel A mixer
W12	All	E8364-20172	1	A20 LODA to A28 channel R1 mixer
W13	All	E8364-20173	1	A20 LODA to A29 channel R2 mixer
W14	All	E8364-20146	1	A20 LODA to W40 (to A30 channel B mixer)
W15	All	E8361-20056	1	A19 splitter to A20 LODA
W16	All	E8361-20057	1	A19 splitter to A20 LODA
W18	All	E8364-20145	1	A17 LOMA 10 to A18 MA 20
W19-W20	All	Refer to "Top Cables--All, All Options Except 080" on page 6-16.		
W40	All	E8364-20032	1	W14 (from A20 LODA) to A30 channel B mixer
W47	All	E8364-20131	1	A43 channel A step attenuator to A27 channel A mixer
W48	All	E8364-20132	1	A44 channel B step attenuator to A30 channel B mixer
W49	E8362C	E8362-20035	1	A IN to A43 channel A step attenuator
	E8363C, E8364C	E8364-20129		
W50	E8362C	E8362-20036	1	B IN to A44 channel B step attenuator
	E8363C, E8364C	E8364-20130		
W51	All	E8364-20055	1	A22 switch splitter to A36 step attenuator
W52	All	E8364-20056	1	A22 switch splitter to A37 step attenuator
W55	All	E8364-20167	1	A38 bias tee to A25 test port 1 coupler
W56	All	E8364-20168	1	A39 bias tee to A26 test port 2 coupler
W60	E8362C	08720-20098	6	Front-panel jumper
	E8363C, E8364C	E8364-20059		
W66	E8362C	E8362-20053	1	Channel R2 attenuator to channel R2 SOURCE OUT A24 detector to channel R2 SOURCE OUT
	E8363C, E8364C	E8364-20048		
W67	E8362C	E8362-20051	1	A25 test port 1 coupler to Port 1 CPLR ARM
	E8363C, E8364C	E8364-20156		
W68	E8362C	E8362-20052	1	A26 test port 2 coupler to Port 2 CPLR ARM
	E8363C, E8364C	E8364-20157		
W71	E8362C	E8362-20038	1	R2 IN to A29 channel R2 mixer
	E8363C, E8364C	E8364-20126		
W81	E8362C	E8362-20024	1	A36 step attenuator to port 1 SOURCE OUT
	E8363C, E8364C	E8364-20053		
W82	E8362C	E8362-20025	1	A37 step attenuator to port 2 SOURCE OUT
	E8363C, E8364C	E8364-20054		
W83	E8362C	E8362-20012	1	Port 1 CPLR THRU to A38 bias tee
	E8363C, E8364C	E8364-20039		
W84	E8362C	E8362-20013	1	Port 2 CPLR THRU to A39 bias tee
	E8363C, E8364C	E8364-20040		
W95	E8362C	E8362-20032	1	A46 reference switch to channel R1 attenuator A46 reference switch to A23 detector
	E8363C, E8364C	E8364-20119		
W96	All	E8364-20127	1	A45 reference switch to A46 reference switch
W97	E8362C	E8362-20033	1	A46 reference switch to REF SOURCE OUT
	E8363C, E8364C	E8364-20121		
W98	E8362C	E8362-20034	1	A45 reference switch to REF R1 IN
	E8363C, E8364C	E8364-20123		
W99	E8362C	E8362-20037	1	A45 reference switch to A28 R1 mixer
	E8363C, E8364C	E8364-20125		
W109	All	E8361-20050	1	A12 source to A47 RF coupler
W110	All	E8361-20053	1	A18 MA 24 to A48 LO coupler
W111	E8362C	E8362-20055	1	A47 RF coupler to A22 switch A47 RF coupler to A21 SOMA 50
	E8363C, E8364C	E8361-20051		
W112	All	E8361-20055	1	A48 LO coupler to A19 splitter
W113	All	E8361-20052	1	A47 RF coupler to rear panel TEST SET DRIVERS RF
W114	All	E8361-20054	1	A48 LO coupler to rear panel TEST SET DRIVERS LO

**Figure 6-29 Bottom Semi-Rigid Cables, Options UNL/014/016/080/081/H11**

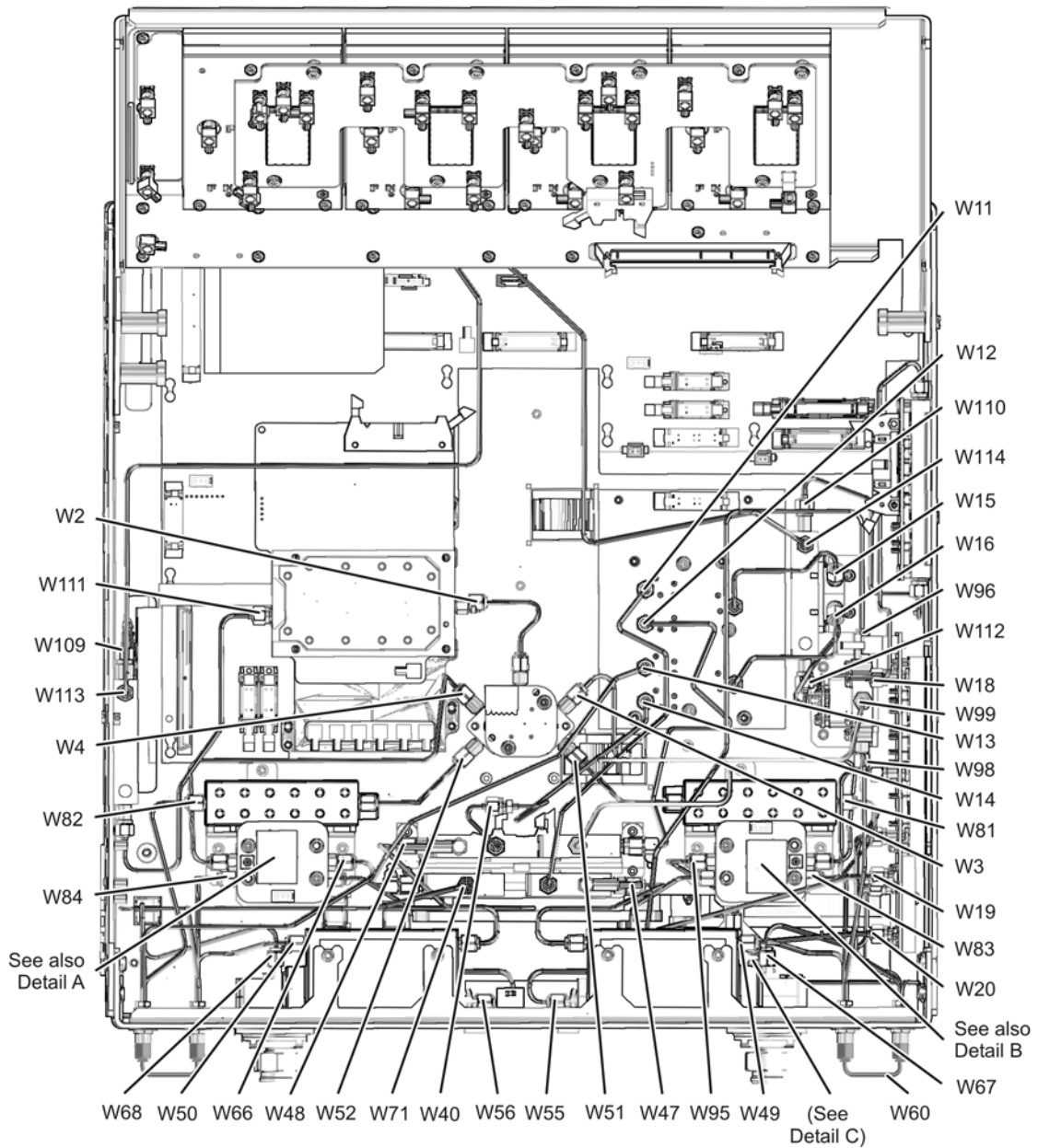

**Detail A (E8362C)**

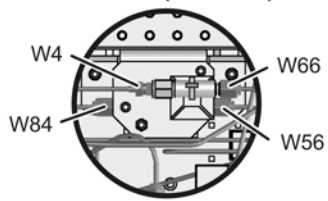

**Detail C**

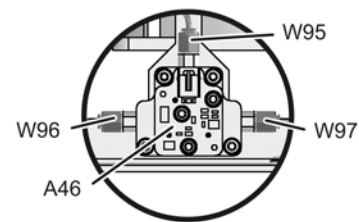

**Detail B (E8362C)**

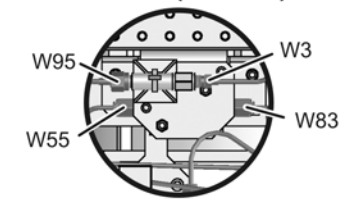

st594cblb\_new

**Bottom Flexible Cables, All Options**

Ref. Desig.	Models	Part Number	Qty	Description
W21	All	E8364-60019	1	A27 channel A mixer to A49 IF multiplexer board
W22	All	E8364-60020	1	A28 channel R1 mixer to A49 IF multiplexer board
W23	All	E8364-60021	1	A29 channel R2 mixer to A49 IF multiplexer board
W24	All	E8364-60022	1	A30 channel B mixer to A49 IF multiplexer board
W25	All	E8364-60126	1	A31 receiver A J400 to A6 SPAM board J3
W26	All	E8364-60127	1	A32 receiver R1 J400 to A6 SPAM board J4
W27	All	E8364-60128	1	A33 receiver R2 J400 to A6 SPAM board J5
W28	All	E8364-60129	1	A34 receiver B J400 to A6 SPAM board J6
W29	All	E8364-60124	1	A10 frequency reference board J4 to A35 receiver motherboard J2
W30	All	E8364-60125	1	A35 receiver motherboard J50 to A11 phase lock board J6
W36	All	E8364-60161	1	A16 test set motherboard J15 to A49 IF multiplexer board J1
W37	E8363C, E8364C	E8364-60121	1	A16 test set motherboard to A23 detector
W38	E8363C, E8364C	E8364-60122	1	A16 test set motherboard to A24 detector
W39	E8363C, E8364C	E8364-60123	1	A16 test set motherboard to A21 SOMA 50
W41	All	8120-5014	1	A49 IF multiplexer board to A31 receiver A
W42				A49 IF multiplexer board to A32 receiver R1
W43				A49 IF multiplexer board to A33 receiver R2
W44				A49 IF multiplexer board to A34 receiver B
W101-W104	All with Option H11	8120-5401	8	Rear panel 8.33 MHz IF IN connectors to A49 IF multiplexer board
W105-W108				Rear panel PULSE IN connectors to A49 IF multiplexer board
W116	All with Option 080	Refer to "Top Cables--All, All Options Including 080" on page 6-20.		

Figure 6-30 Bottom Flexible Cables, All Options

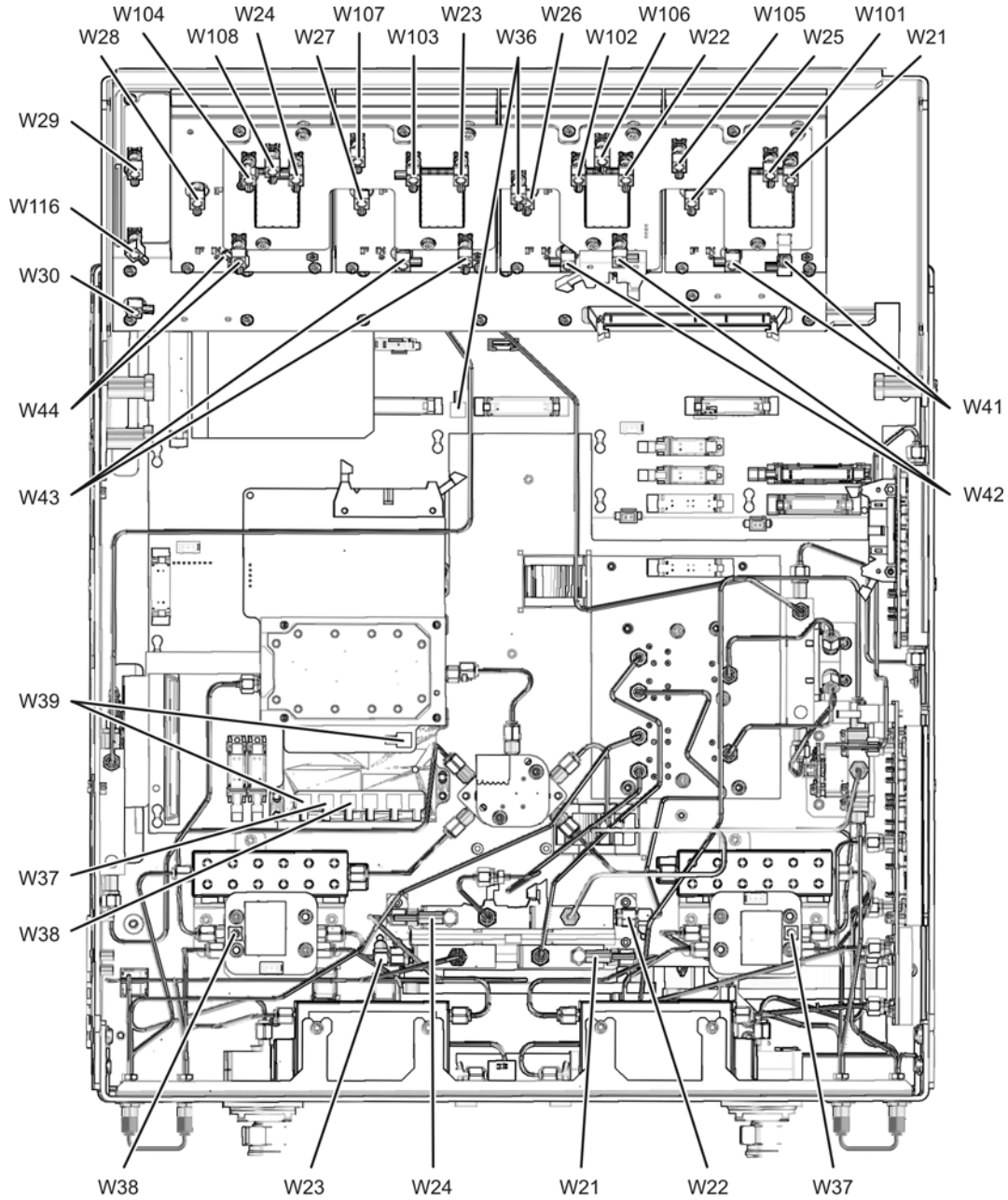

st570b

### Bottom Ribbon Cables and Wrapped-Wire, All Options

Ref. Desig.	Type <sup>a</sup>	Part Number	Description
①	50R	8121-0817	A41 hard disk drive assembly to A15 CPU board
②	40R	8121-0834	A16 test set motherboard P701 (MAT HDLR) to rear-panel connector, Handler I/O
③	26R	8121-0818	A21 SOMA 50 (E8363C/E8364C only) to A16 test set motherboard J4 (SOMA50)
④	60R	8121-0965	A16 test set motherboard J2 (RCVR) to A35 receiver motherboard and A49 IF multiplexer board
⑤	16R	8121-0816	A20 LODA to A16 test set motherboard J11 (LODA)
⑥	24R	8121-0815	A18 MA 24 to A16 test set motherboard J7 (MA20)
⑦	20R	8121-0846	A17 LOMA 12 to A16 test set motherboard J10 (LOMA10)
⑧	2W	8121-0966	A45 reference transfer switch to A16 test set motherboard J31 (-SW1)
			A46 reference transfer switch to A16 test set motherboard J30 (+SW1)
⑨	2W	8121-0803	A22 switch splitter to A16 test set motherboard J500
⑩	20R	E7340-60075	A23 detector (E8363C/E8364C only) to A16 test set motherboard J5 (R1 DET)
			A24 detector (E8363C/E8364C only) to A16 test set motherboard J6 (R2 DET)
⑪	10R	8121-0819	A43 receiver step attenuator to A16 test set motherboard P500 (P1 RCVR ATT)
			A44 receiver step attenuator to A16 test set motherboard P501 (P2 RCVR ATT)
⑫	10R	8121-0819	A36 source step attenuator to A16 test set motherboard P510 (P1 SRC ATT)
⑬	10R	8121-0119	A37 source step attenuator to A16 test set motherboard P512 (P2 SRC ATT)
⑭	14R	8121-0814	Mixer bias board to A16 test set motherboard J3 (MIXERS)
⑮	4W	8121-0802	Front-panel LED board to A16 test set motherboard J502
⑯	100R	8121-0118	A16 test set motherboard J1 to A14 system motherboard J8

a. nW = n wires in a wrapped cable; nR = n wires in a ribbon (flat) cable

Figure 6-31 Bottom Ribbon Cables and Wrapped Wire, All Options

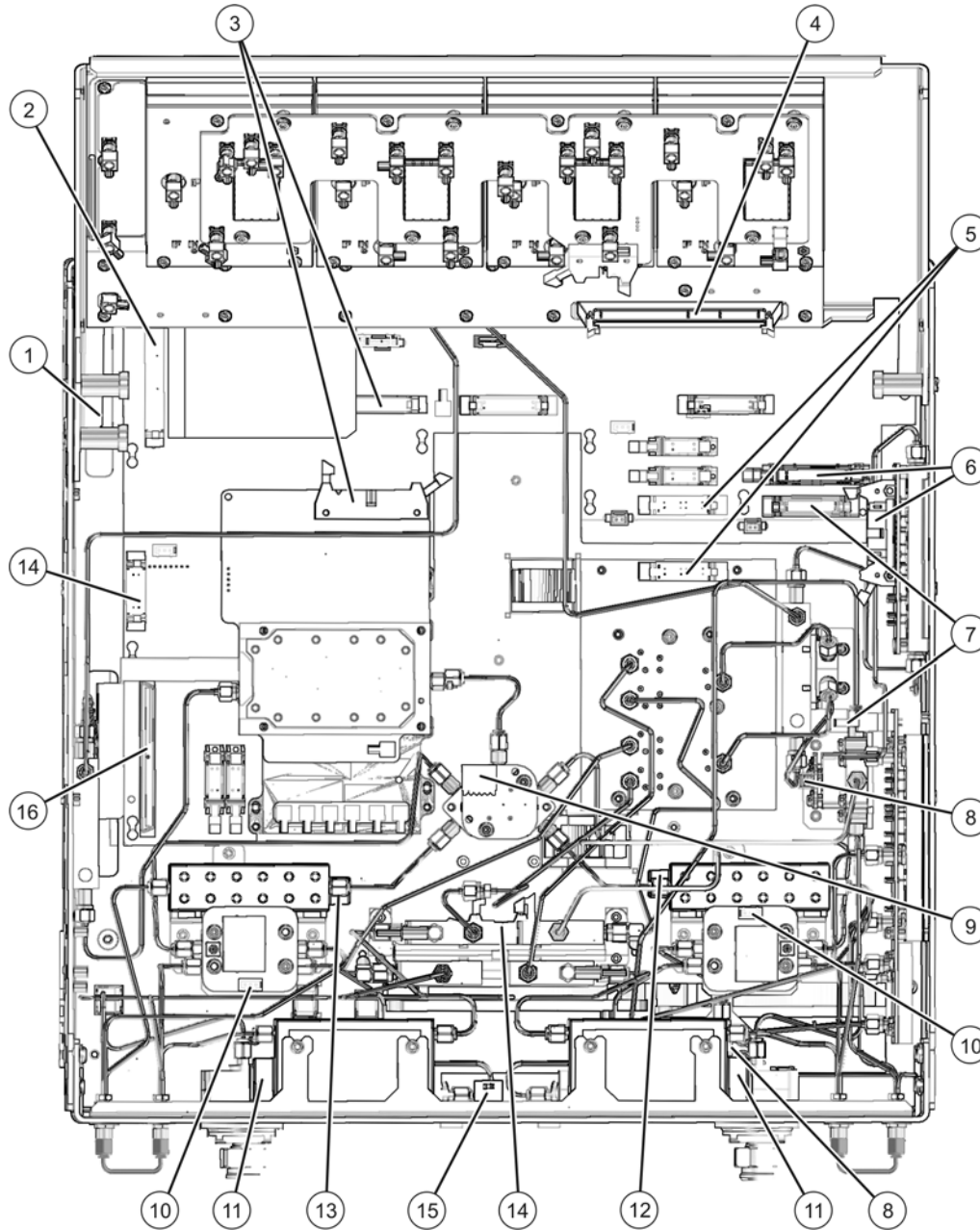

st564b

### Top Hardware, All Options

Ref. Desig.	Part Number	Qty	Description
B1	Fans	Refer to <a href="#">"Internal Hardware and Parts, All Options"</a> on page 6-74.	
①	5022-6134	1	Cable hold down wire, large
②	E8361-60059	1	USB hub board
③	E8356-60024	1	Hard disk drive interface board
④	E8356-00014	1	Bracket (for hard disk drive interface board ③)
⑤	0515-0430	2	Machine screw, M3.0 x 6, pan head (for bracket ④)
⑥	E8356-40001	1	Air flow plenum
⑦	5022-6135	1	Cable hold down wire, small
⑧	0515-1934	2	Machine screw, M2.5 x 6, pan head (to secure item ②)
⑨	0515-0374	1	Machine screw, M3.0 x 10, pan head (for cable hold down wire ⑦)
⑩	0515-2799	2	Machine screw, with patch lock, M3.0 x 10, pan head (for cable hold down wire ①, air flow plenum ⑥, and A11 phase lock board)
⑪	3050-0891	2	Washer, flat (for patch lock screw ⑩)



Figure 6-32 Top Hardware, All Options

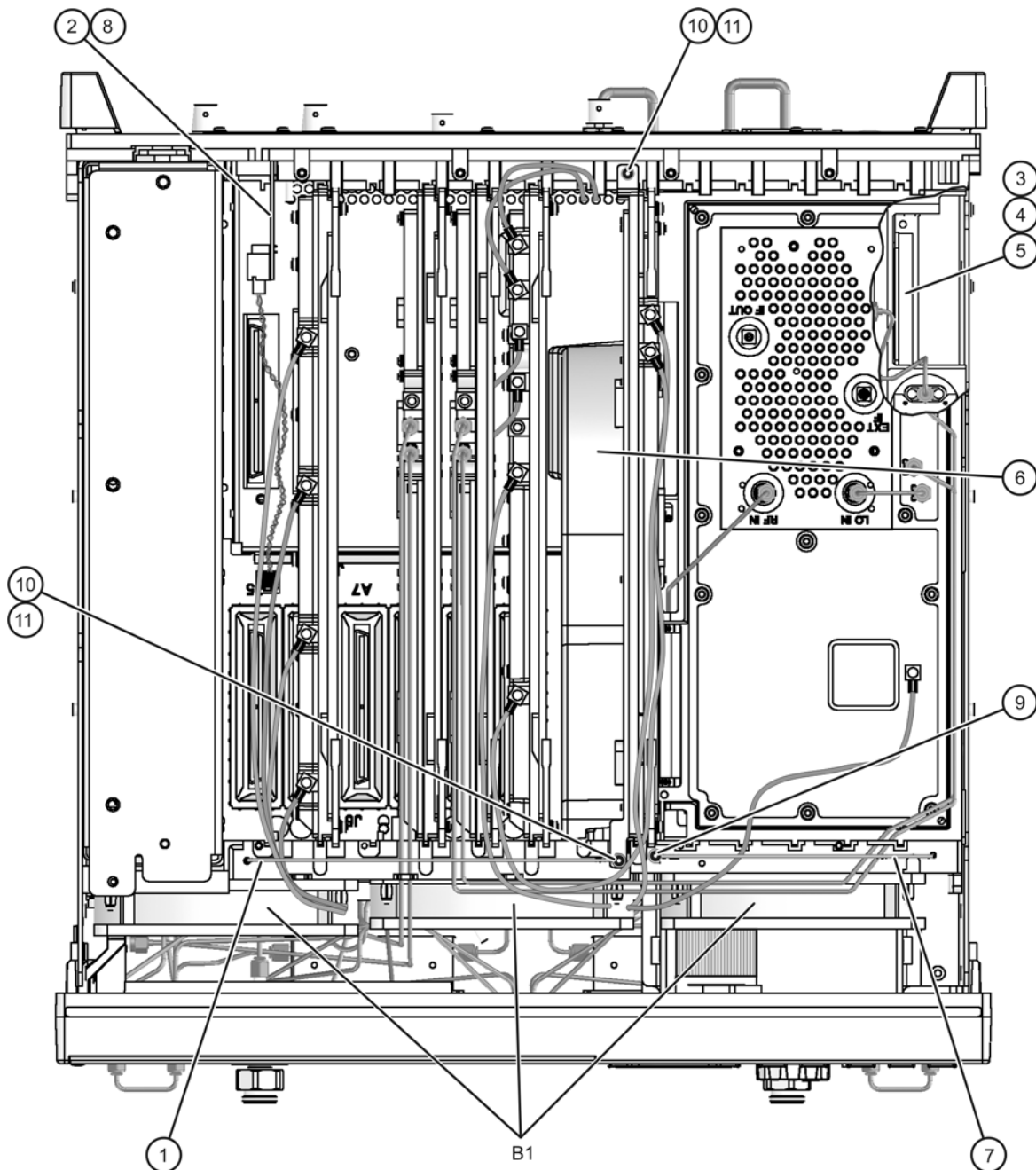

8361\_001\_604

### Bottom Hardware, All Options

Ref. Desig.	Part Number	Qty	Description
①	E8364-00002	2	Detector/attenuator/bias tee bracket
②	0515-0430	10	Machine screw M3.0 x 6 pan head (Detector brackets-3 ea; front-panel LED board-3; A19 splitter bracket-2; A45 switch bracket-2)
③	0515-0374	16	Machine screw M3.0 x 10 pan head (A17-4; A18-4; A20-2; A22-2; mixer bracket-4)
④	0515-0664	10	Machine screw M3.0 x 12 pan head (A19-2; A16-4; A45-2; A46-2)
⑤	0515-0658	8	Machine screw M2.0 x 6 pan head (A36-2; A37-2; A47-2; A48-2)
⑥	0515-1349	16	Machine screw M3.0 x 30 pan head (A31–A34-3 ea; A21-4)
⑦	E8364-00007	1	Hard disk drive shield, stationary bracket
⑧	0515-0666	37	Machine screw M3.0 x 18 pan head (A35 casting-13; A20-4; A27–A30-3 ea; A23/A24-4 ea; E8363C/E8364C only)
⑨	0515-0372	10	Machine screw M3.0 x 8 pan head (A35-2; mixer bias board-4; A43-2; A44-2)
⑩	0515-1644	8	Machine screw M3.0 x 12 flat head (A49-8)
⑪	1400-3014	1	Cable clamp
⑫	0515-2141	4	Machine screw M2.5 x 14 pan head (A38-2; A39-2)
⑬	08720-60182	1	Front-panel LED board
⑭	E8364-20115	1	mixer bracket
⑮	E8364-60140	1	mixer bias board
⑯	5022-1087	2	Test port coupler nut

Figure 6-33 Bottom Hardware, All Options

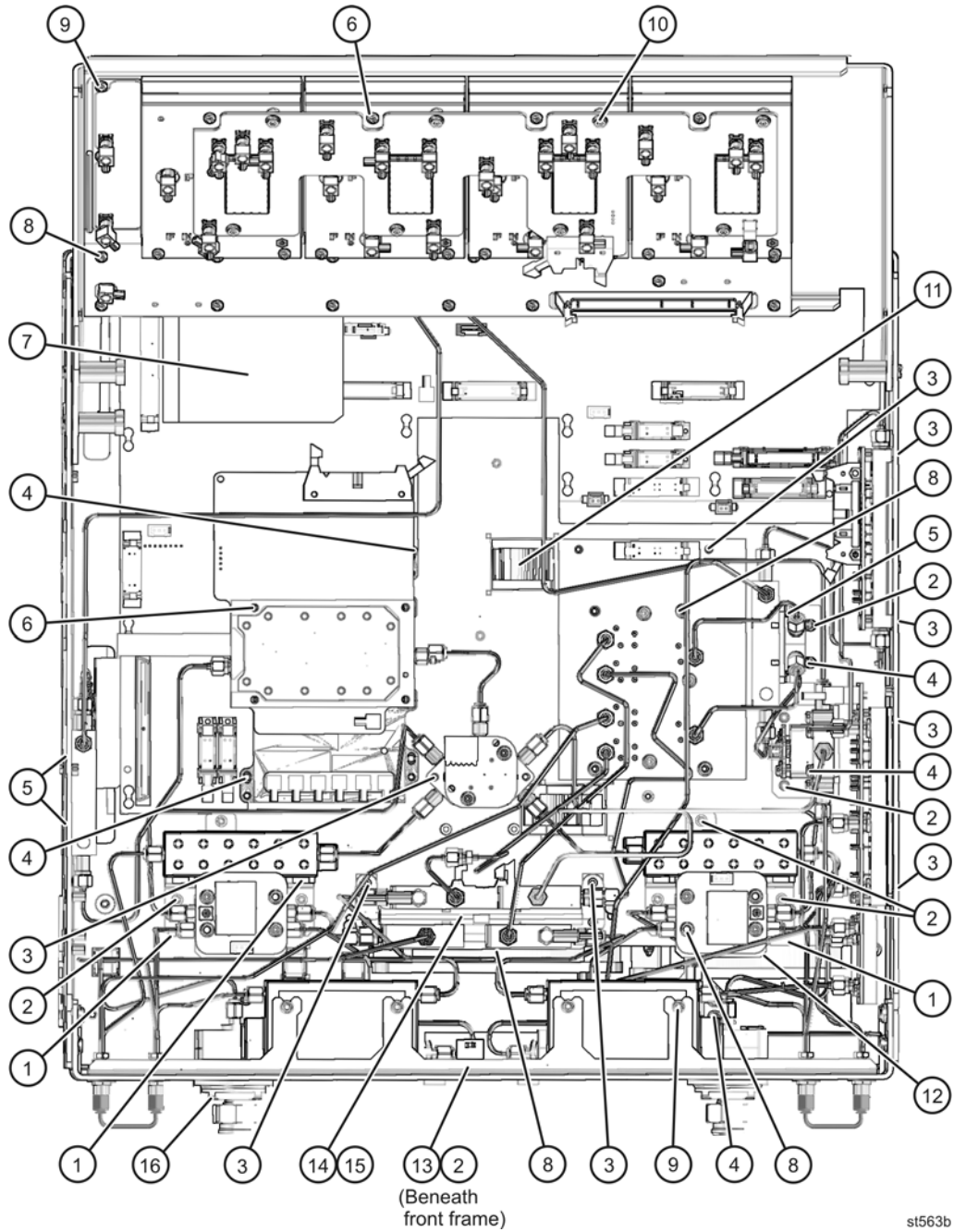

### Internal Hardware and Parts, All Options

Ref. Desig.	Models	Part Number	Qty	Description
B1	All	3160-1085	3	Fan
①	All	E8356-00027	1	Chassis assembly
②	All	E8364-00013	1	Test set deck
③	E8362C	E8362-00003	1	Test set deck front panel
	E8363C, E8364C	E8364-00014		
④	All	These feed-through connectors, including the nuts and washers, are part of the individual cables. Refer to the appropriate bottom semi-rigid cables illustration in this chapter to determine the part number of the cable assembly.		
⑤	All	E8356-40004	1	Line switch button
⑥	All	1460-2632	1	Line switch spring
⑦	All	E4406-60109	1	Midweb assembly (includes three fans)
⑧	All	0515-1227	8	Machine screw, M3 x 6, flathead
⑨	All	E4406-60109	1	Midweb assembly (includes three fans, B1)
⑩	All	E8364-00021	1	Clamp, ribbon cable
⑪	All	0515-0374	1	Machine screw M3.0 x 10, pan head (for cable clamp, item ⑩)

Figure 6-34 Internal Hardware and Parts, All Options

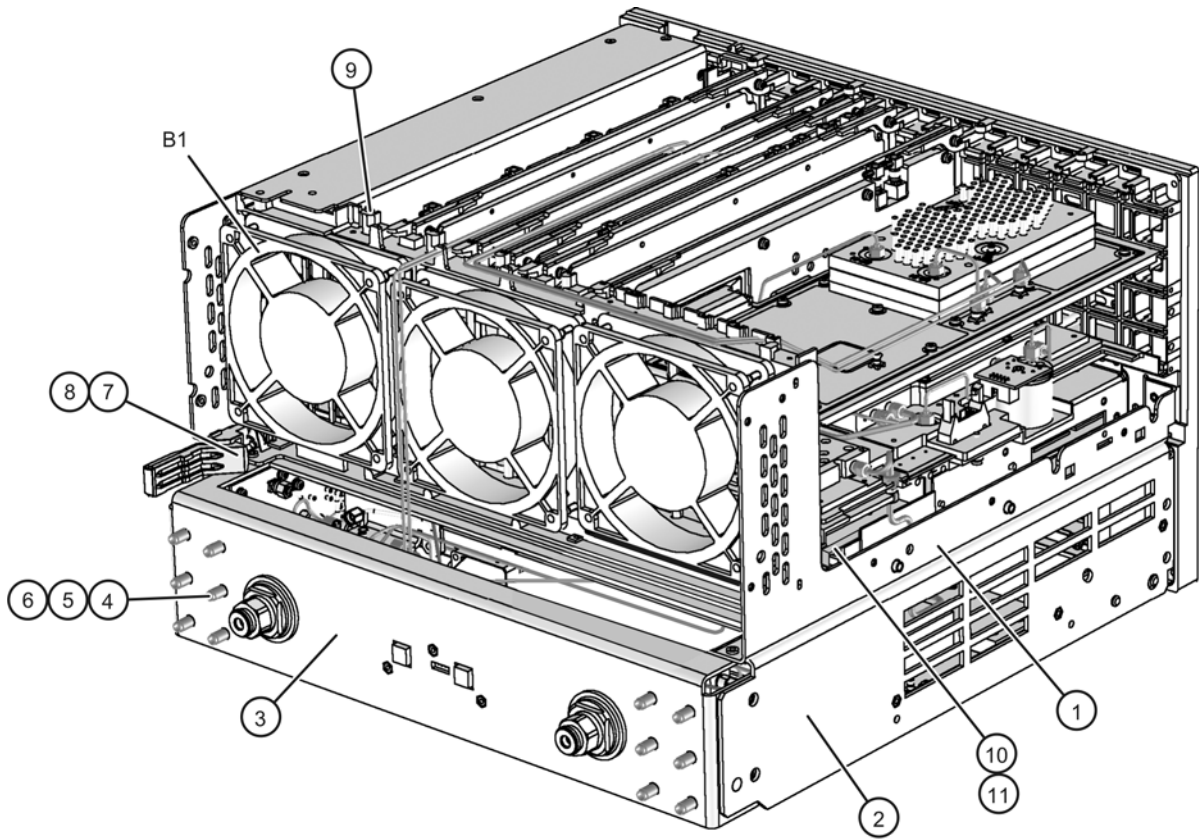

st531b\_new

## External Hardware and Parts, All Options

Ref. Desig.	Part Number	Qty	Description
A1	Keypad assembly		Refer to "Front Panel Assembly, Back Side, All Options" on page 6-12.
A2	Display assembly		
RPG	Front knob		
①	E8356-00011	1	Inner cover
②	N5230-00011	1	Outer cover
③	5041-9611	4	Rear feet
④	0515-1619	4	Machine screw, M4.0 x 25, pan head
⑤	E4400-60026	2	Strap handle assembly (includes item ⑥)
⑥	0515-0710	4	Machine screw, M5.0 x 18, flathead
⑦	5041-9167	4	Bottom feet
	5021-2840	4	Key lock (for securing bottom foot)
⑧	5041-9183	2	With handles—front handle side trim
	5041-9174	2	Without handles—trim strip, filler
⑨	5063-9205	2	Front handle
⑩	E8361-20067	2	Clip, retainer
⑪	0515-1644	2	Machine screw M3.0 x 12, flat head (for retainer clip, item ⑩)

Figure 6-35 External Hardware and Parts, All Options

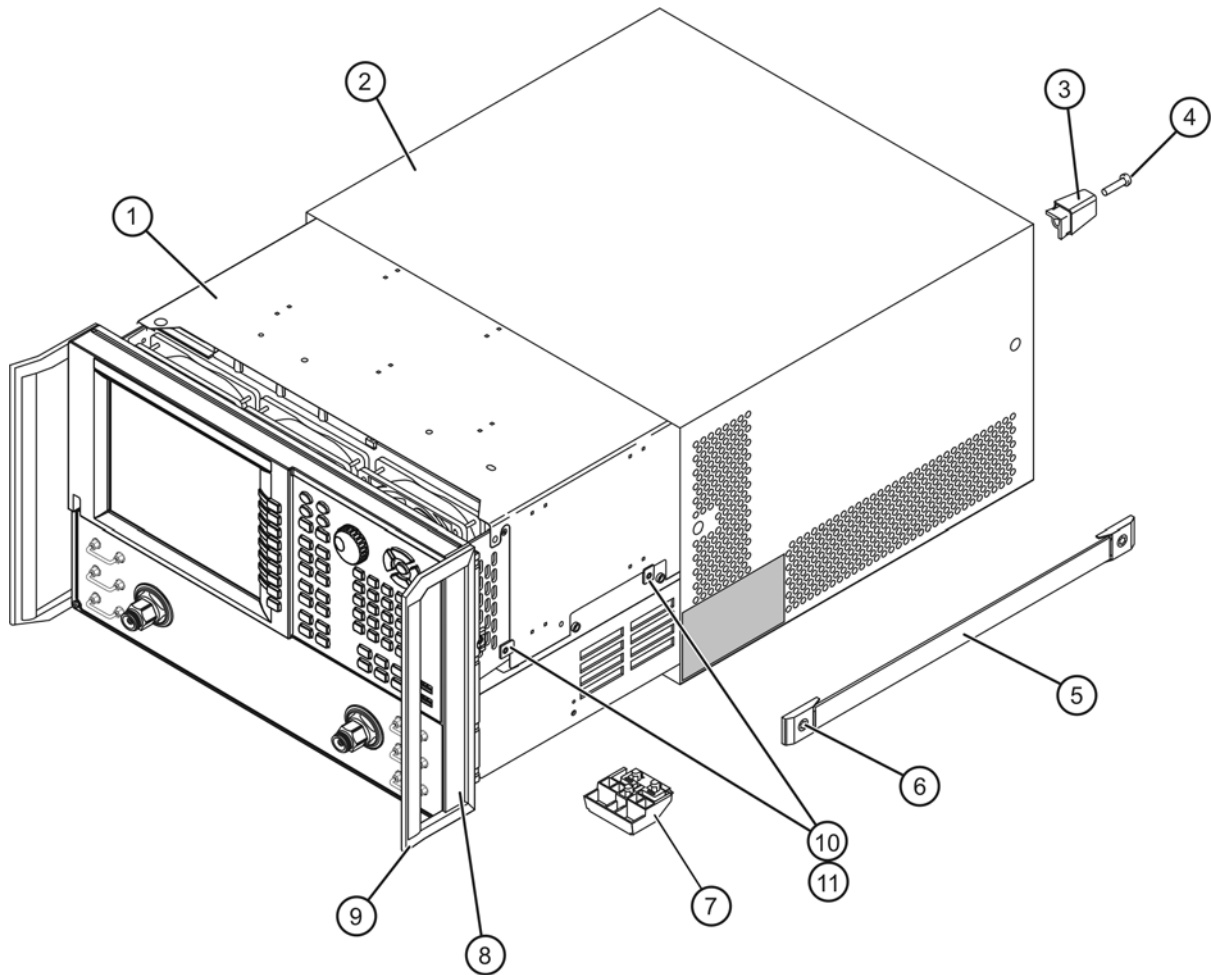

st534a\_new

## Rear Panel Assembly, All Options

Item Number	Part Number	Qty	Description
①	E8364-60023	1	Rear frame assembly (includes items ②–⑦)
②	E8356-00023	1	Cover plate, large
③	6960-0149	10	Hole plug (only 2 installed if Option H11 is installed)
④	0515-0372	33	Machine screw, M3.0 x 8, pan head
⑤	8120-5055	2	BNC cable assembly
⑥	2950-0035	4	Hex nut (for BNC cable assemblies ⑤ and ⑧)
⑦	2190-0102	4	Lock washer (for BNC cable assemblies ⑤ and ⑧)
⑧	8120-5027	2	BNC cable assembly
⑨	E8356-00037	1	Cover plate, USB hub. Refer to “ <a href="#">Top Hardware, All Options</a> ” on page 6-70 for the part number of the USB hub board.
⑩	0515-0374	9	Machine screw, M3.0 x 10, pan head
⑪	E8361-00006	1	Test set motherboard rear panel (P/O A16)
⑫	85047-60005	2	Fuse holder (includes wire harness, nut, and washer) <sup>a</sup>
⑬	1400-0112	2	Fuse holder cap
⑭	E8364-00018	1	Cover (not shown), for bias connectors and fuse holders (Installed only on analyzers without Option UNL.)
⑮	These connectors are part of their respective cables. Refer to “ <a href="#">Bottom Flexible Cables, All Options</a> ” on page 6-66. Hole plugs (item ③) are installed here if Option H11 is not installed.		
⑯	6960-0076	2	Hole plug (if Option H11 is not installed)
⑰	1250-1251	2	SMA connector, f-f
⑱	1810-0118	2	SMA coaxial termination, 50 ohm
⑲	E8364-60095	1	Hard disk drive stationary board with mating connector
⑳	0515-1410	2	Machine screw, M3.0 x 20, pan head (to secure item ⑲)
㉑	8121-0834	1	HANDLER I/O cable assembly
not shown	0380-4670	--	Jackscrew, to secure multipin cable connectors to rear panel
not shown	1251-7812	--	Jackscrew, to secure multipin cable connectors to rear panel

a. See [page 6-86](#) for the part number of the fuses.



**Figure 6-36 Rear Panel Assembly, All Options**

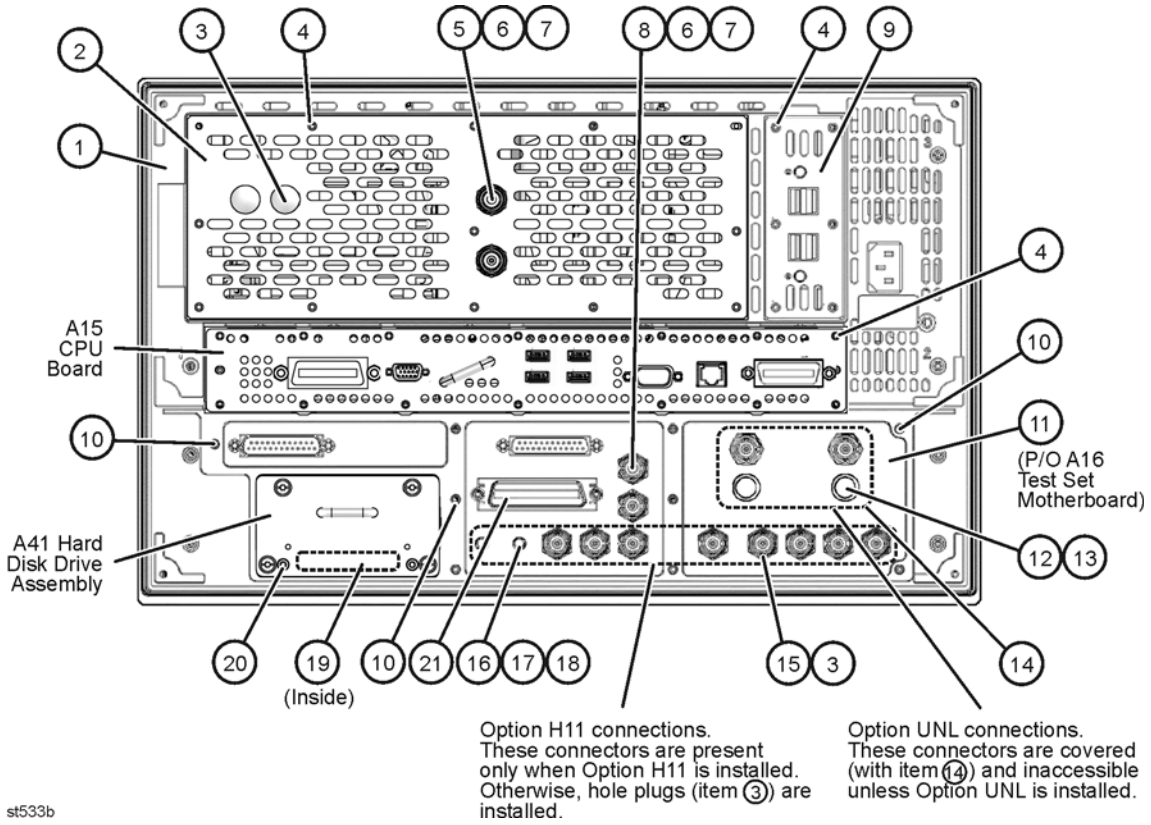

st533b

## Hard Disk Drive Assembly, All Options

### Parallel ATA Interface

Every PNA shipped prior to January 2009 contains the parallel ATA interface for the hard disk drive (HDD). Starting January 2009, every PNA shipped contains the serial ATA interface for the HDD. The table below lists the contents of the HDD with the parallel ATA interface.

Ref. Desig.	Part Number	Qty	Description
	N8982A <sup>a</sup> Kit ( <i>for 1.1 GHz CPU board</i> )		Hard disk drive assembly kit with programmed hard disk drive (HDD) (Includes A41 and items ① through ⑦, pre-assembled.)
A41	N5230-60048	1	Programmed hard disk drive
①	E8364-20118	1	Hard disk drive bracket
②	0515-0664	4	Machine screw, M3.0 x 12 pan head
③	0515-0372	2	Machine screw, M3.0 x 8 pan head
④	0340-1525	8	Bushing
⑤	E8364-60094	1	Hard disk drive board
⑥	1440-0421	1	U-handle, finger grip
⑦	0515-1227	2	Machine screw, M3.0 x 6 flathead (for U-handle)

- a. All new N8982A assemblies will be shipped with serial ATA hard drives and associated hardware.

Figure 6-37. Hard Disk Drive Assembly (Parallel ATA Interface)

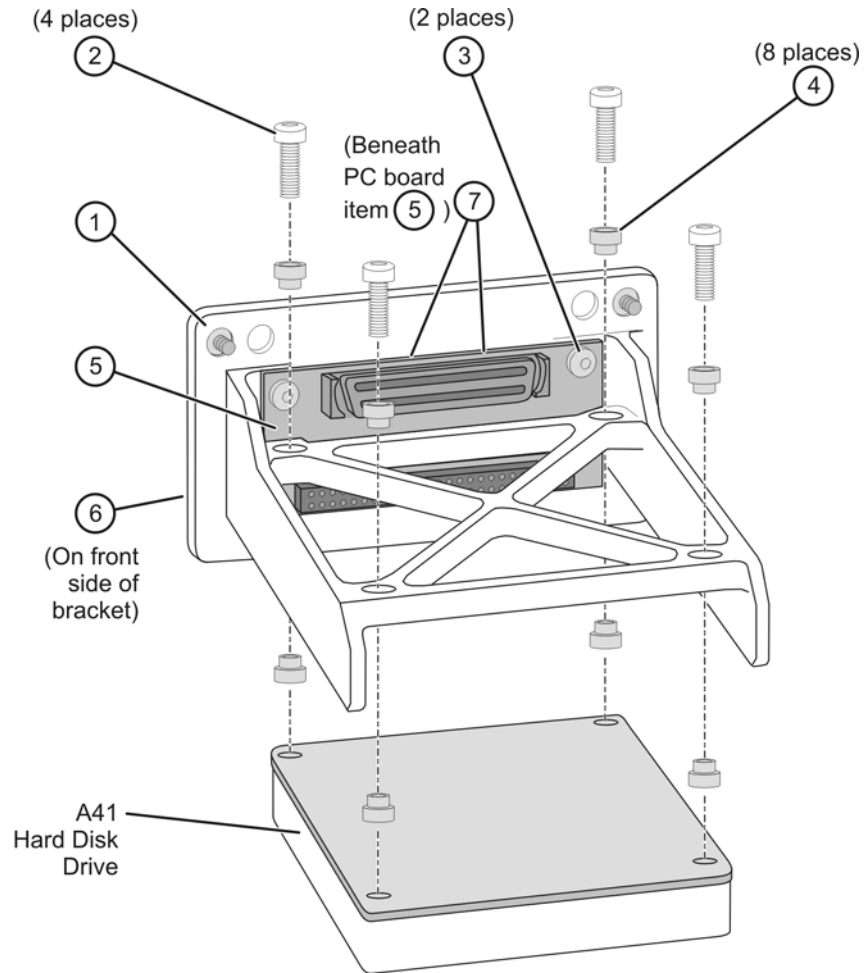

Note: The N8982A hard disk drive kit includes the A41 hard disk drive and items 1 through 7, pre-assembled.

st532a\_new

### Serial ATA Interface

Every PNA shipped prior to January 2009 contains the parallel ATA interface for the hard disk drive (HDD). Starting January 2009, every PNA shipped contains the serial ATA interface for the hard disk drive (HDD). The table below lists the contents of the HDD with the serial ATA interface.

Ref. Desig.	Part Number	Qty	Description
	N8982A Kit ( <i>for 1.1 GHz CPU board</i> )		Hard disk drive assembly kit with programmed hard disk drive (HDD) (Includes A41 and items ① through ⑨, pre-assembled.)
A41	N5230-60050	1	Programmed hard disk drive
①	E8364-20118	1	Hard disk drive bracket
②	0515-0664	4	Machine screw, M3.0 x 12 pan head
③	0515-0372	2	Machine screw, M3.0 x 8 pan head
④	E8361-20069	2	Bushing
⑤	E8361-63125	1	Hard disk drive board
⑥	1440-0421	1	U-handle, finger grip
⑦	0515-1227	2	Machine screw, M3.0 x 6 flathead (for U-handle)
⑧	E8361-20068	1	Nylon spacer
⑨	0340-1525	4	Bushing

Figure 6-38 Hard Disk Drive Assembly (Serial ATA Interface)

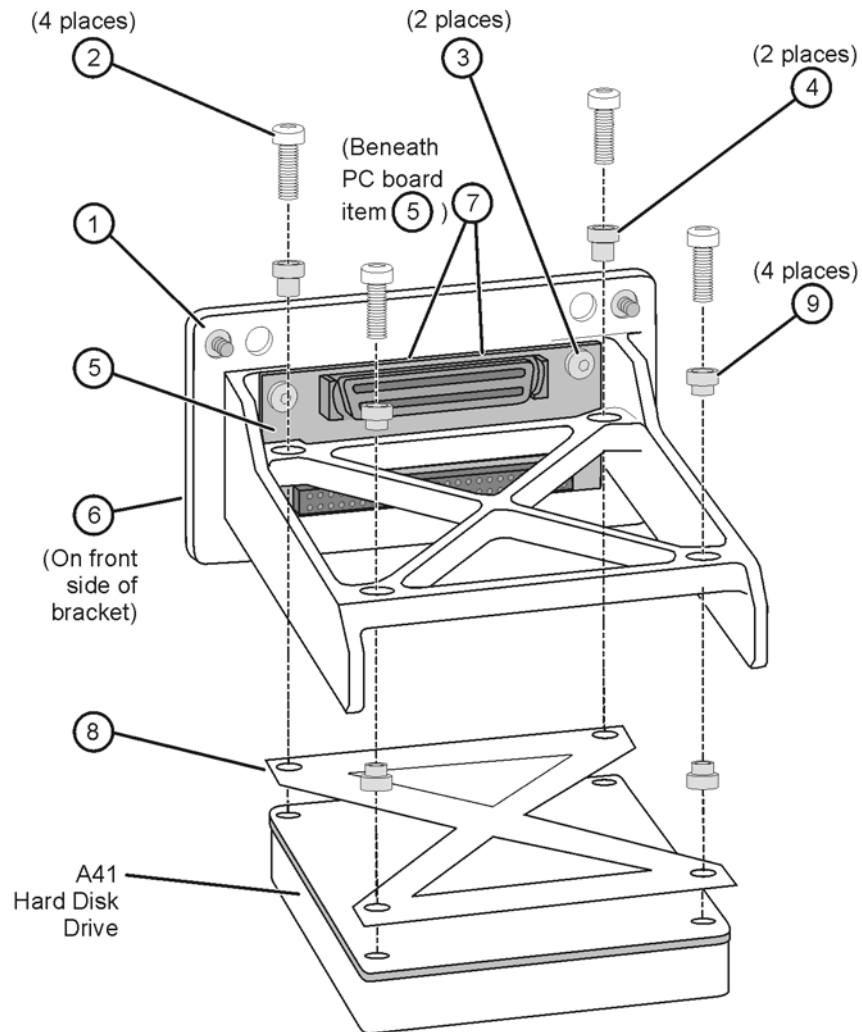

Note: N8980A and N8981A hard disk drive kits include the A41 hard disk drive and items 1 through 9, pre-assembled.

St532a1

## Miscellaneous Part Numbers

**Table 6-3 Part Numbers for Miscellaneous Parts and Accessories**

Description	Model or Part Number <sup>a</sup>
<b>Service Tools</b>	
Extender board, synthesizer/reference	E8356-60021
20-mm open-end torque wrench (included with analyzer); 0.9 N-m (8 in-lb)	8710-1764
1/4-in and 5/16-in open-end wrench, thin profile	8710-0510
5/16-in (8 mm), open-end torque wrench; 0.9 N-m (8 in-lb)	8710-1765
Spanner wrench	08513-20014
<b>Documentation</b>	
Installation and Quick Start Guide (for all PNA series analyzers) (Cannot be ordered. Part number is for reference only. Must be printed from the Agilent Web site. Refer to <a href="#">“Printing Copies of Documentation from the Web”</a> on page iv.)	E8356-90001
Service Guide (Not available in printed form. Part number is for reference only. Must be printed from the Agilent Web site. Refer to <a href="#">“Printing Copies of Documentation from the Web”</a> on page iv.)	E8364-90038
<b>Protective Caps for Connectors</b>	
Front panel jumper guard	E8361-00009
Protective cap for GPIB connector	1252-5007
Protective cap for Test Set I/O connector	1252-1935
Protective cap for Aux I/O connector	1252-4691
Protective cap for Handler I/O connector	1253-5320
Protective cap for Display (VGA) connector	1252-3422
Protective cap for Serial (RS-232) connector	1252-0220
Protective cap for Parallel (1284-C) connector	1252-1935
Protective cap for Test port (Port 1, Port 2) connector (E8363C, E8364C)	1401-0247
<b>GPIB Cables/GPIB Adapter</b>	
GPIB cable, 0.5 meter (1.6 feet)	10833D
GPIB cable, 1 meter (3.3 feet)	10833A
GPIB cable, 2 meter (6.6 feet)	10833B
GPIB cable, 4 meter (13.2 feet)	10833C
GPIB cable to GPIB cable adapter	10834A
<b>Battery</b>	
Battery, lithium, 3V, .22A-HR (located on the A15 CPU board)	1420-0356

**Table 6-3 Part Numbers for Miscellaneous Parts and Accessories (Continued)**

Description	Model or Part Number <sup>a</sup>
<b>E8362C Upgrade Kits</b>	
Time domain (Option 010)	E8362CU-010
Configurable test set (Option 014)	E8362CU-014
Receiver attenuators (Option 016)	E8362CU-016
Extended frequency range to 40 GHz; for models w/o option 014 (Option 040)	E8362CU-040
Extended frequency range to 40 GHz; for models with option 014 (Option 041)	E8362CU-041
Extended frequency range to 50 GHz; for models with option 014 (Option 050)	E8362CU-050
Extended frequency range to 50 GHz; for models w/o option 014 (Option 051)	E8362CU-051
Frequency offset mode (Option 080)	E8362CU-080
Reference mixer transfer switches (Option 081)	E8362CU-081
Mixer measurement application (Option 083)	E8362CU-083
Add built-in performance test software for Agilent inclusive calibration perpetual license (Option897)	E8362CU-897
Add built-in performance test software for standards compliant calibration perpetual license (Option898)	E8362CU-898
Pulse measurement capability (Option H08)	E8362CU-H08
IF access (Option H11)	E8362CU-H11
60-dB source attenuators and bias tees (Option UNL)	E8362CU-UNL
<b>E8363C, E8364C Upgrade Kits</b>	
Time domain (Option 010)	E8363/4CU-010
Configurable test set (Option 014)	E8363/4CU-014
Receiver attenuators (Option 016)	E8363/4CU-016
Extended frequency range to 50 GHz; E8363C with or w/o Option 014 (Option 050)	E8363CU-050
Extended frequency range to 67 GHz; for models w/o option 014 (Option 067)	E8363/4CU-067
Extended frequency range to 67 GHz; for models with option 014 (Option 068)	E8363/4CU-068
Frequency offset mode (Option 080)	E8363/4CU-080
Reference mixer transfer switches (Option 081)	E8363/4CU-081
Mixer measurement application (Option 083)	E8363/4CU-083
Add built-in performance test software for Agilent inclusive calibration perpetual license (Option897)	E8363/4CU-897
Add built-in performance test software for standards compliant calibration perpetual license (Option898)	E8363/4CU-898

**Table 6-3 Part Numbers for Miscellaneous Parts and Accessories (Continued)**

Description	Model or Part Number <sup>a</sup>
Pulse measurement capability (Option H08)	E8363/4CU-H08
IF access (Option H11)	E8363/4CU-H11
60-dB source attenuators and bias tees (Option UNL)	E8363/4CU-UNL
<b>Fuses</b>	
Rear Panel Bias Input Fuse Port 1, Port 2 (0.5 A, 125 V) (Option UNL)	2110-0046
<b>Touch-up Paint</b>	
Dove gray ( <i>for use on frame around front panel and painted portion of handles</i> )	6010-1146
French gray ( <i>for use on cover</i> )	6010-1147
Parchment white ( <i>for use on rack mount flanges, rack support flanges, and front panels</i> )	6010-1148
<b>USB Accessories</b>	
Mouse	1150-7799
Keyboard (U.S. style)	1150-7896
Read/write CD-ROM	N4688A
<b>Rack Mount Kits and Handle Kits</b>	
Rack mount kit for use with standard supplied front handles (Option 1CP)	5063-9237
Rack mount flange for use with front handles (two included in 5063-9237)	5022-2809
Rack mount kit for use without front handles (Option 1CM)	1CM042A Was 5063-9217
Rack mount flange for use without front handles (two included in 1CM042A)	5022-2802
Front handle kit (two handles and hardware)	5063-9230
Front handle (two included in 5063-9230)	5063-9205
Rack mount rail set	E3663AC
<b>EMI/RFI Shielding Accessories</b>	
7 mm ferrite bead for serial cable	9170-1793
9 mm ferrite bead (spare for parallel port)	9170-1702
<b>ESD Supplies</b>	
Adjustable antistatic wrist strap	9300-1367
Antistatic wrist strap grounding cord ( <i>5 foot length</i> )	9300-0980
Static control table mat and earth ground wire	9300-0797
ESD heel strap	9300-1126

a. E8363/4C is used to represent a range of model numbers and should be replaced with one of the following, as appropriate: E8363C or E8364C



---

## **7 Repair and Replacement Procedures**

---

## Information in This Chapter

This chapter contains procedures for removing and replacing the major assemblies of your Agilent Technologies PNA series microwave network analyzer.

### Chapter Seven at-a-Glance

Section Title	Summary of Content	Start Page
<a href="#">Before Starting the Removal and Replacement Procedures</a>	Warnings and cautions pertaining to personal safety and ESD protection.  The proper assembly replacement sequence for your analyzer.	<a href="#">Page 7-3</a>
<a href="#">Table of Removal and Replacement Procedures</a>	A table of removal and replacement procedures and the corresponding page number where they are located.	<a href="#">Page 7-4</a>
<a href="#">Removal and Replacement Procedures</a>	The actual procedures for removing and replacing the major assemblies in your analyzer.  <i>The procedures occur in assembly reference designator numerical order.</i>	See <a href="#">Table 7-1 on page 7-4</a> for specific procedures.
<a href="#">Post-Repair Procedures</a>	A table for the proper tests, verifications, and adjustments to perform on your analyzer after repair.	<a href="#">Page 7-82</a>

---

## Before Starting the Removal and Replacement Procedures

Before starting the removal and replacement procedures, review these warnings, cautions, and the assembly replacement sequence.

### Personal Safety Warnings

---

**WARNING** These servicing instructions are for use by qualified personnel only. To avoid electrical shock, do not perform any servicing unless you are qualified to do so.

---

**WARNING** The opening of covers or removal of parts is likely to expose dangerous voltages. Disconnect the analyzer from all voltage sources while it is being opened.

---

**WARNING** The power cord is connected to internal capacitors that may remain live for 10 seconds after disconnecting the plug from its power supply assembly. Wait at least 10 seconds, after disconnecting the plug, before removing the covers.

---

### Electrostatic Discharge (ESD) Protection

---

**CAUTION** Many of the assemblies in this instrument are very susceptible to damage from electrostatic discharge (ESD). Perform the following procedures only at a static-safe workstation and wear a grounded wrist strap.

This is important. If not properly protected against, electrostatic discharge can seriously damage your analyzer, resulting in costly repair.

To reduce the chance of electrostatic discharge, follow all of the recommendations outlined in [“Electrostatic Discharge Protection” on page 1-6](#), for all of the procedures in this chapter.

---

### Assembly Replacement Sequence

The following steps show the sequence that you should follow to replace an assembly in the network analyzer.

- Step 1.** Identify the faulty group. Begin with [Chapter 4, “Troubleshooting.”](#)
- Step 2.** Order a replacement assembly. Refer to [Chapter 6, “Replaceable Parts.”](#)
- Step 3.** Replace the faulty assembly and determine what adjustments are necessary. Refer to [“Post-Repair Procedures”](#) in this chapter.
- Step 4.** Perform the necessary adjustments. Refer to [Chapter 3, “Tests and Adjustments.”](#)
- Step 5.** Perform the necessary performance tests. Refer to [Chapter 3, “Tests and Adjustments.”](#)

## Removal and Replacement Procedures

**Table 7-1 List of Procedures**

Reference Designator	Assembly Type	Location
N/A	Covers, outer and inner	Page 7-6
N/A	Receiver deck	Page 7-8
N/A	Midweb and fans	Page 7-76
N/A	Front panel assembly	Page 7-10
N/A	30-dB fixed attenuators (E8362C only)	Page 7-46
N/A	Mixer bias board (part of A27, A28, A29, A30 procedure)	Page 7-52
N/A	USB hub board	Page 7-79
N/A	Battery	Page 7-80
A1	Keypad assembly	Page 7-12
A2	Display assembly	
A3	Front panel interface board	
A4	Power supply assembly	Page 7-16
A6	SPAM board	
A8	Fractional-N synthesizer board	Page 7-18
A9	Fractional-N synthesizer board (Option 080)	
A10	Frequency reference board	
A11	Phase lock board	Page 7-20
A12	Source 20	Page 7-22
A13	Frequency offset receiver board	Page 7-24
A14	System motherboard	Page 7-26
A15	CPU board	Page 7-28
A16	Test set motherboard	Page 7-32
A17	LOMA 10	Page 7-34
A18	MA 20	Page 7-36
A19	Splitter	Page 7-38
A20	LODA	Page 7-40
A21	SOMA 50 (E8363C and E8364C only)	Page 7-42

**Table 7-1 List of Procedures**

<b>Reference Designator</b>	<b>Assembly Type</b>	<b>Location</b>
A22	Switch splitter	<a href="#">Page 7-44</a>
A23	Detector (E8363C and E8364C only)	<a href="#">Page 7-48</a>
A24	Detector (E8363C and E8364C only)	
A25	Test port 1 coupler	<a href="#">Page 7-50</a>
A26	Test port 2 coupler	
A27	Channel A first converter (mixer)	<a href="#">Page 7-52</a>
A28	Channel R1 first converter (mixer)	
A29	Channel R2 first converter (mixer)	
A30	Channel B first converter (mixer)	
A31	Channel A receiver module	<a href="#">Page 7-54</a>
A32	Channel R1 receiver module	
A33	Channel R2 receiver module	
A34	Channel B receiver module	
A35	Receiver motherboard	<a href="#">Page 7-56</a>
A36	Port 1 60-dB source step attenuator (Option UNL)	<a href="#">Page 7-58</a>
A37	Port 2 60-dB source step attenuator (Option UNL)	
A38	Port 1 bias tee (Option UNL)	<a href="#">Page 7-60</a>
A39	Port 2 bias tee (Option UNL)	
A40	Not used.	
A41	Hard disk drive	<a href="#">Page 7-62</a>
A43	Channel A 35-dB receiver step attenuator (Option 016)	<a href="#">Page 7-70</a>
A44	Channel B 35-dB receiver step attenuator (Option 016)	
A45	Channel R1 reference channel transfer switch (Option 081)	<a href="#">Page 7-72</a>
A46	Channel R1 reference channel transfer switch (Option 081)	
A47	RF path coupler (Option H11)	<a href="#">Page 7-74</a>
A48	LO path coupler (Option H11)	
A49	IF multiplexer board (part of A31, A32, A33, A34 procedure)	<a href="#">Page 7-54</a>

---

## Removing the Covers

### Tools Required

- T-10 TORX driver (set to 9 in-lb)
- T-20 TORX driver (set to 21 in-lb)

### Removing the Outer Cover

---

**CAUTION** This procedure is best performed with the analyzer resting on its front handles in the vertical position. *Do not place the analyzer on its front panel without the handles.* This will damage the front panel assemblies.

---

Refer to [Figure 7-1](#) for this procedure.

1. Disconnect the power cord.
2. With a T-20 TORX driver, remove the strap handles (item ①) by loosening the screws (item ②) on both ends until the handle is free of the analyzer.
3. With a T-20 TORX driver, remove the four rear panel feet (item ③) by removing the center screws (item ④).
4. Slide the four bottom feet (item ⑤) off the cover.
5. Slide the cover off of the frame.

### Removing the Inner Cover

Refer to [Figure 7-1](#) for this procedure.

1. With a T-10 TORX driver, remove the cover attachment screws (item ⑥). Some of these screws are flat head and some are pan head. Note the locations of each type for reinstallation.
2. With a T-10 TORX driver, loosen the screws on the two retainer clips (item ⑦).
3. Lift off the cover.

### Replacement Procedure

Reverse the order of the removal procedures.

Be sure that the cover is located behind the two retainer clips (item ⑦) before installing the cover screws (item ⑥). Remember to tighten the retainer clip screws. The retainer clips may rotate slightly when the screws are tightened; this is normal and acceptable.

Figure 7-1 Outer and Inner Cover Removal

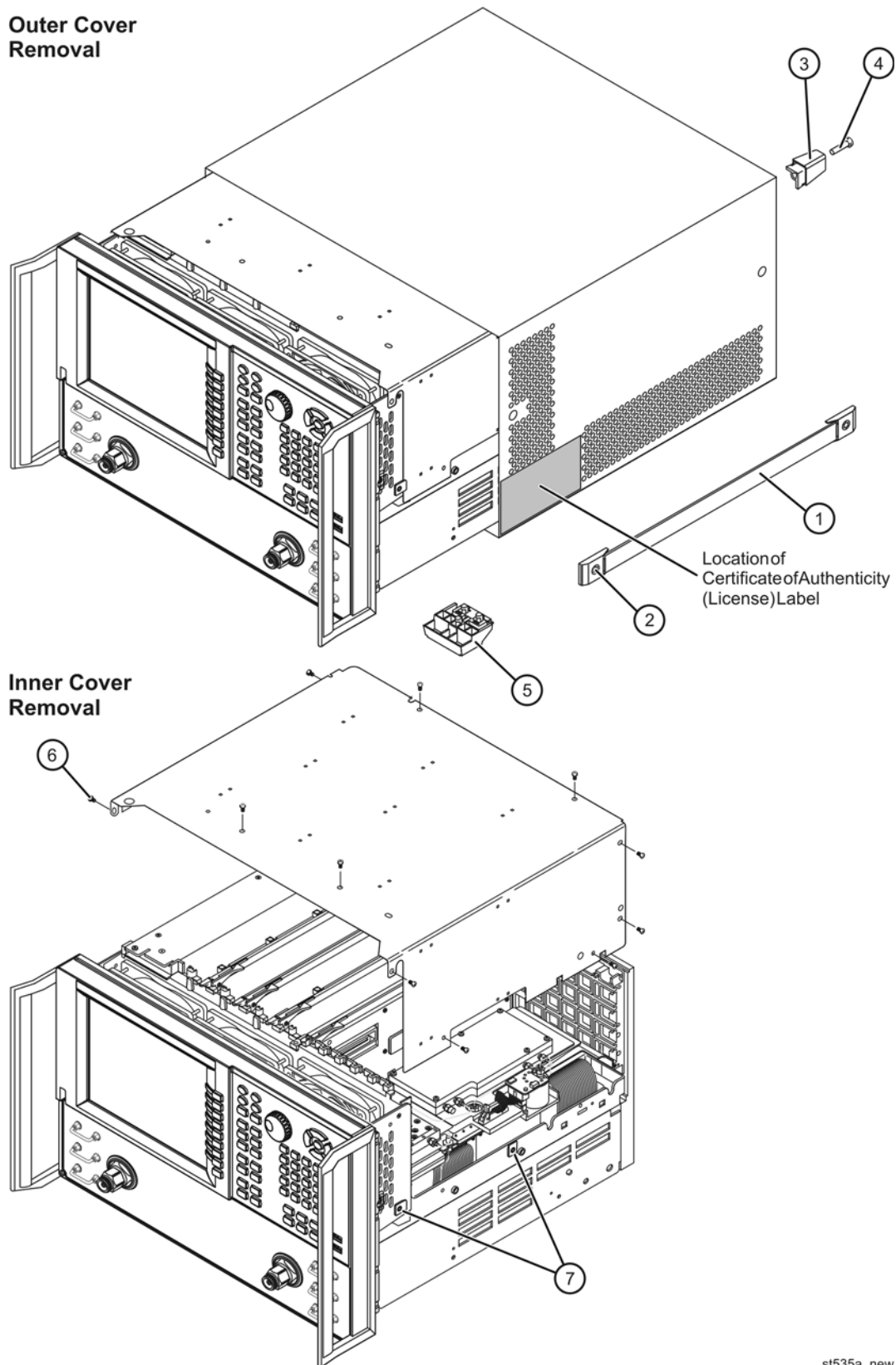

st535a\_new

---

## Raising and Removing the Receiver Deck

### Tools Required

- T-10 TORX driver (set to 9 in-lb)

### Raising the Receiver Deck

Refer to [Figure 7-2](#) for this procedure.

1. Disconnect the power cord.
2. Remove the outer cover.
3. Place the analyzer bottom-side up on a flat surface.
4. With a T-10 TORX driver, remove the four screws (item ①), securing the receiver deck.
5. Pull the latch pin (item ②) toward the center of the analyzer to release receiver deck.
6. Lift the receiver deck to partially raise it, then release the latch pin (item ②). Lift the receiver deck to its fully raised position and ensure that the latch pin latches in the raised position.

### Lowering the Receiver Deck

Refer to [Figure 7-2](#) for this procedure.

1. Pull the latch pin (item ②) toward the center of the analyzer to release the receiver deck.
2. Lift the receiver deck to partially lower it, then release the latch pin (item ②). Lower the receiver deck to its fully lowered position and ensure that the latch pin latches in the lowered position.
3. With a T-10 TORX driver, install the four screws (item ①), to secure the receiver deck.

### Removing the Receiver Deck

Refer to [Figure 7-2](#) for this procedure.

1. Raise the receiver deck as outlined in [“Raising the Receiver Deck,”](#) above.
2. Disconnect the flexible cables (item ③) and the two ribbon cables (item ④). Label the cables and connectors for proper reconnection later.
3. Pull the latch pin (item ⑤) to release one side of the receiver deck.
4. Lift the side of the receiver deck that was just released, above the side of the analyzer, and then lift the entire receiver deck out of the analyzer.

### Replacing the Receiver Deck

Refer to [Figure 7-2](#) for this procedure.

1. Reverse the procedure for [“Removing the Receiver Deck,”](#) above.



Figure 7-2 Receiver Deck, Raising and Removal

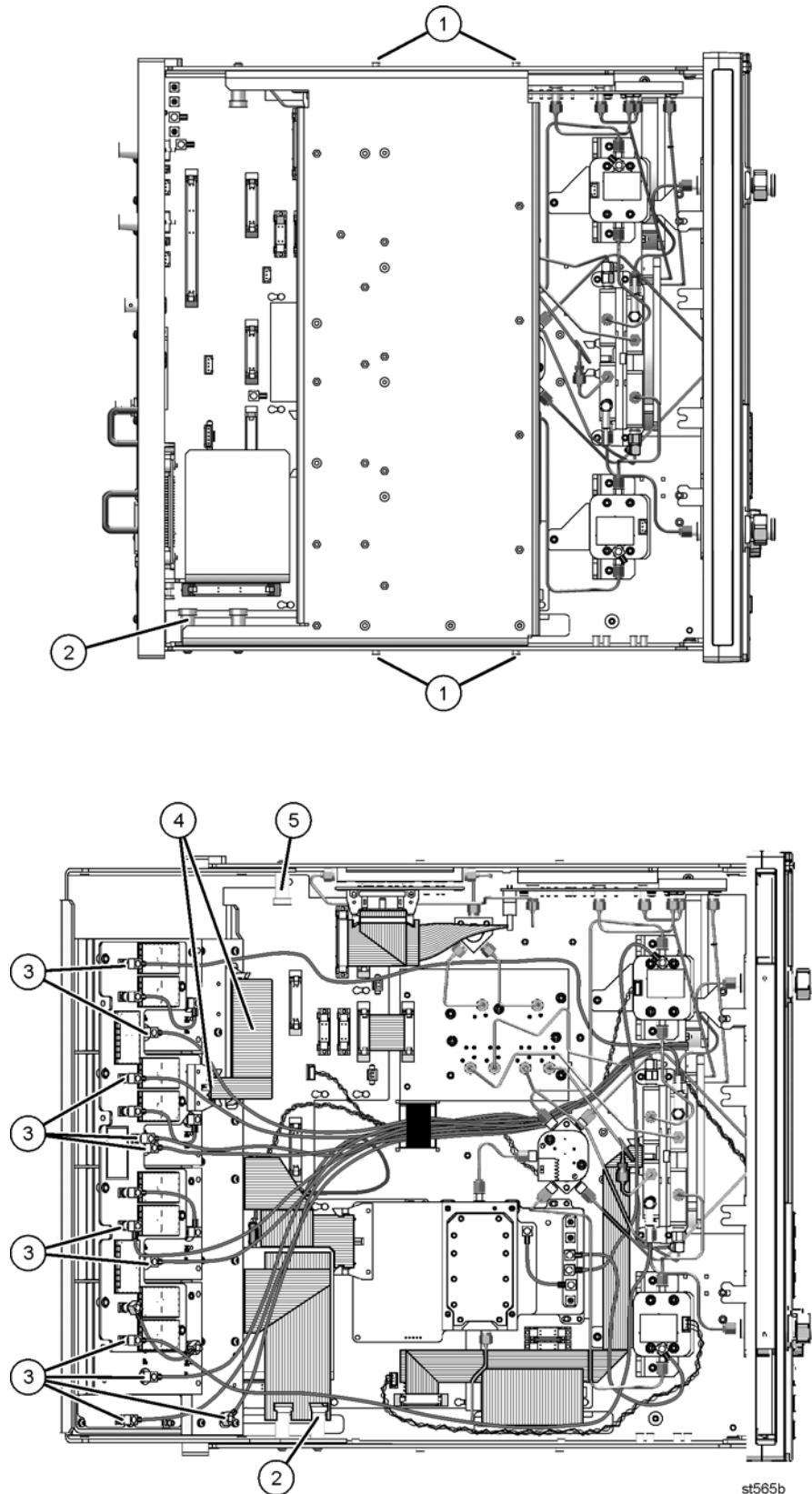

---

## Removing and Replacing the Front Panel Assembly

### Tools Required

- T-10 TORX driver (set to 9 in-lb)
- T-20 TORX driver (set to 21 in-lb)
- 5/16 inch open-end torque wrench (set to 10 in-lb)
- ESD grounding wrist strap

### Removal Procedure

Refer to [Figure 7-3](#) for this procedure.

1. Disconnect the power cord.
2. Remove the outer cover. Refer to “[Removing the Covers](#)” on page 7-6.
3. With a 5/16 inch torque wrench, remove all the semirigid jumpers (item ①) from the front panel (Option 014 only).
4. With a T-10 TORX driver, remove the eight screws (item ②) from the sides of the frame.

---

**CAUTION** Before removing the front panel from the analyzer, lift and support the front of the analyzer frame.

---

5. Slide the front panel over the test port connectors.
6. Disconnect the front panel interface ribbon cable (item ③).

The front panel is now free from the analyzer.

### Replacement Procedure

---

**CAUTION** When replacing the front panel, be sure to align the power switch to its corresponding front panel cutout.

---

**IMPORTANT** When reconnecting semirigid cables, torque the cable connectors to 10 in-lb.

---

1. Reverse the order of the removal procedure.
2. Perform the post-repair adjustments, verifications, and performance tests that pertain to this removal procedure. Refer to [Table 7-2 on page 7-82](#).

**Figure 7-3** Front Panel Assembly Removal

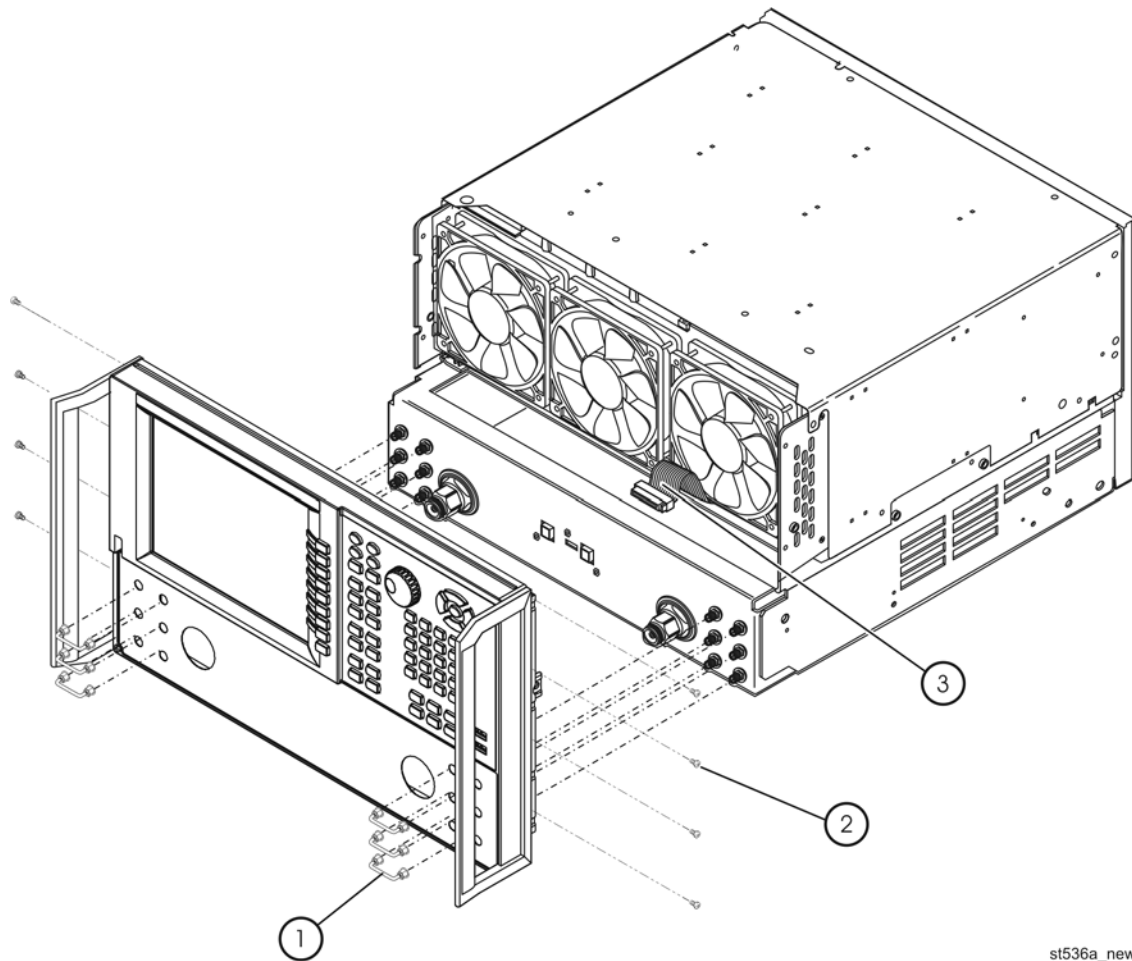

st536a\_new

---

## Removing and Replacing Front Panel Subassemblies

### Tools Required

- T-10 TORX driver (set to 9 in-lb)
- T-20 TORX driver (set to 21 in-lb)
- 5/16 inch open-end torque wrench (set to 10 in-lb)
- ESD grounding wrist strap

Refer to [Figure 7-4](#) for the following procedures.

### Pre-replacement Procedure

1. Disconnect the power cord.
2. Remove the front panel assembly. Refer to [“Removing and Replacing the Front Panel Assembly”](#) on page 7-10.

### Replacing the Inverter Board

1. Remove the inverter board shield by removing the two retaining screws (item ①).
2. Disconnect the two A2 display cables (item ②) from the inverter board.
3. Disconnect the inverter cable (item ③) from the inverter board.
4. Remove the two retaining screws (item ④) from the inverter board.
5. Remove the inverter board from the front panel assembly.
6. Install the new inverter board by reversing the removal instructions.
7. Perform the post-repair adjustments, verifications, and performance tests that pertain to this replacement procedure. Refer to [Table 7-2 on page 7-82](#).

### Replacing the Touch Screen Controller Board

1. Disconnect the touch screen display cable (item ⑤) from the touch screen controller board.
2. Disconnect the touch screen controller cable (item ⑥) from the touch screen controller board. NOTE THAT THE CABLE CONNECTS TO THE UPPER FIVE PINS ON THE CONTROLLER BOARD CONNECTOR. THIS IS IMPORTANT FOR RE-INSTALLATION.
3. Remove the two retaining screws (item ⑦) from the touch screen controller board.
4. Remove the touch screen controller board from the front panel assembly.
5. Install the new touch screen controller board by reversing the removal instructions.
6. Perform the post-repair adjustments, verifications, and performance tests that pertain to this replacement procedure. Refer to [Table 7-2 on page 7-82](#).

## Replacing the A2 Display Assembly

1. Remove the inverter board. Refer to the procedure on [page 7-12](#). Remove the inverter cable from the cable clamp (item ⑧).
1. Remove the touch screen controller board. Refer to above procedure.
2. Remove the six retaining screws (item ⑨) from the A2 display assembly.
3. Remove the A2 display assembly from the front panel assembly.
4. Install the new A2 display assembly by reversing the removal instructions.
5. Perform the post-repair adjustments, verifications, and performance tests that pertain to this replacement procedure. Refer to [Table 7-2 on page 7-82](#).

**Figure 7-4 Front Panel Subassemblies Removal**

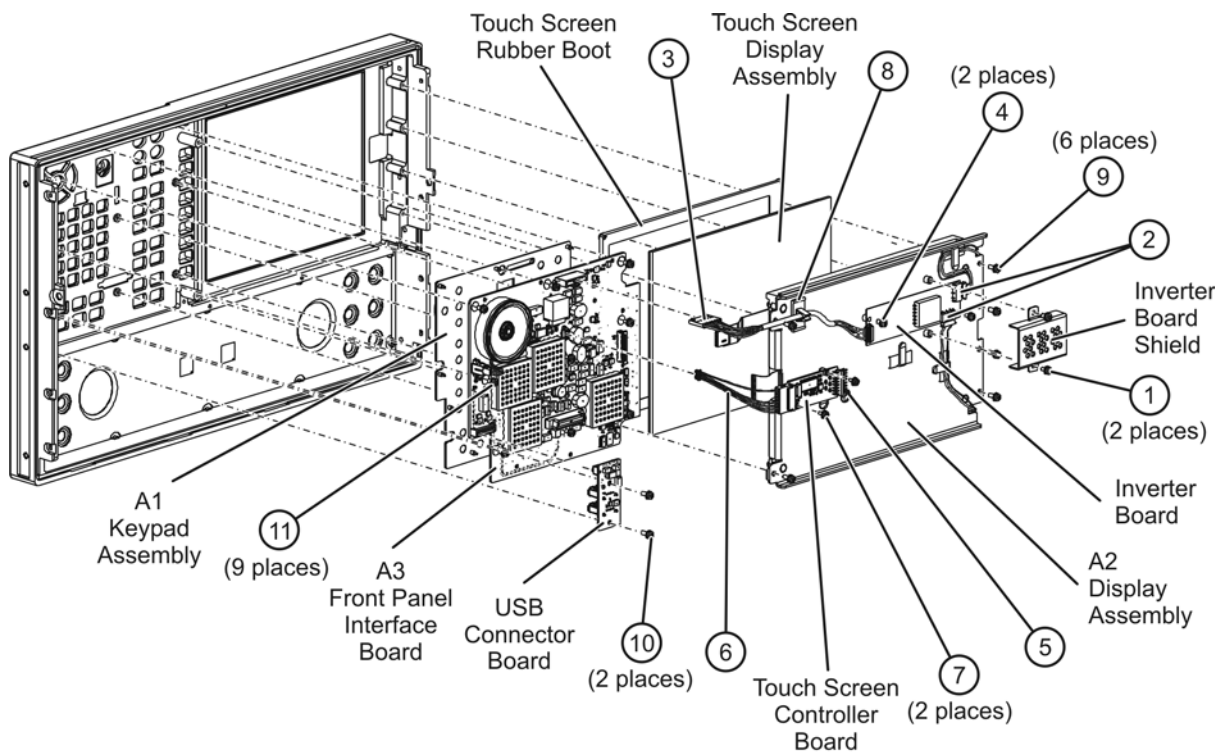

st537a\_new

## Replacing the USB Connector Board

1. Remove the two retaining screws (item ⑩) from the USB connector board.
2. Carefully unplug the USB connector board from the A3 front panel interface board and remove it from the front panel assembly
3. Install the new USB controller board by reversing the removal instructions.
4. Perform the post-repair adjustments, verifications, and performance tests that pertain to this replacement procedure. Refer to [Table 7-2 on page 7-82](#).

## Replacing the A3 Front Panel Interface Board

1. Remove the round knob (RPG) from the front panel by gently pulling the knob forward.
2. Disconnect the inverter cable (item ③) from the A3 front panel interface board.
3. Disconnect the touch screen controller cable (item ⑥) from the A3 front panel interface board.
4. Remove the USB connector board. Refer to previous procedure.
5. Remove the nine retaining screws (item ⑪) from the A3 front panel interface board.
6. Remove the A3 front panel interface board from the front panel assembly.
7. Note how the A1 keypad assembly is attached to the A3 front panel interface board to aid in installing it on the new A3 front panel interface board.
8. Carefully remove the A1 keypad assembly from the A3 front panel interface board.
9. Install the A1 keypad assembly on the new A3 front panel interface board.
10. Reinstall the A3 front panel interface board by removing the removal instructions.
11. Perform the post-repair adjustments, verifications, and performance tests that pertain to this replacement procedure. Refer to [Table 7-2 on page 7-82](#).

## Replacing the A1 Keypad Assembly

1. Remove the A3 front panel interface board as instructed above.
2. Note how the A1 keypad assembly is attached to the A3 front panel interface board to aid in installing the new one.
3. Carefully remove the A1 keypad assembly from the A3 front panel interface board.
4. Install the new A1 keypad assembly on the A3 front panel interface board.
5. Reinstall the A3 front panel interface board by reversing the removal instructions.
6. Perform the post-repair adjustments, verifications, and performance tests that pertain to this replacement procedure. Refer to [Table 7-2 on page 7-82](#).

## Replacing the Touch Screen Display Assembly

1. Refer to [Figure 7-4](#) and [Figure 7-5](#) for this procedure.
2. Remove the A2 display assembly. Refer to the procedure on [page 7-13](#).
3. Note the orientation of the touch screen display in the front panel frame. **THIS IS VERY IMPORTANT. THE NEW ONE MUST BE INSTALLED IN EXACTLY THE SAME ORIENTATION.** Refer to [Figure 7-5](#).
4. Carefully lift the touch screen display and remove it from the front panel assembly.
5. Note the orientation of the rubber boot surrounding the touch screen display. **THIS IS VERY IMPORTANT. THE BOOT MUST BE REINSTALLED EXACTLY AS IT WAS.**
6. Remove the protective cover from the new touch screen then remove the rubber boot from the old touch screen and install it on the new touch screen. Refer to [Figure 7-5](#).
7. Install the new touch screen display and the A2 display by reversing the removal instructions. Refer to [Figure 7-5](#). **REMEMBER, THE TOUCHSCREEN CONTROLLER CABLE CONNECTS TO THE UPPER FIVE PINS ON THE CONTROLLER BOARD CONNECTOR.**
8. Perform the post-repair adjustments, verifications, and performance tests that pertain to this replacement procedure. Refer to [Table 7-2 on page 7-82](#).

**Figure 7-5 Touch Screen Display and Rubber Boot Installation**

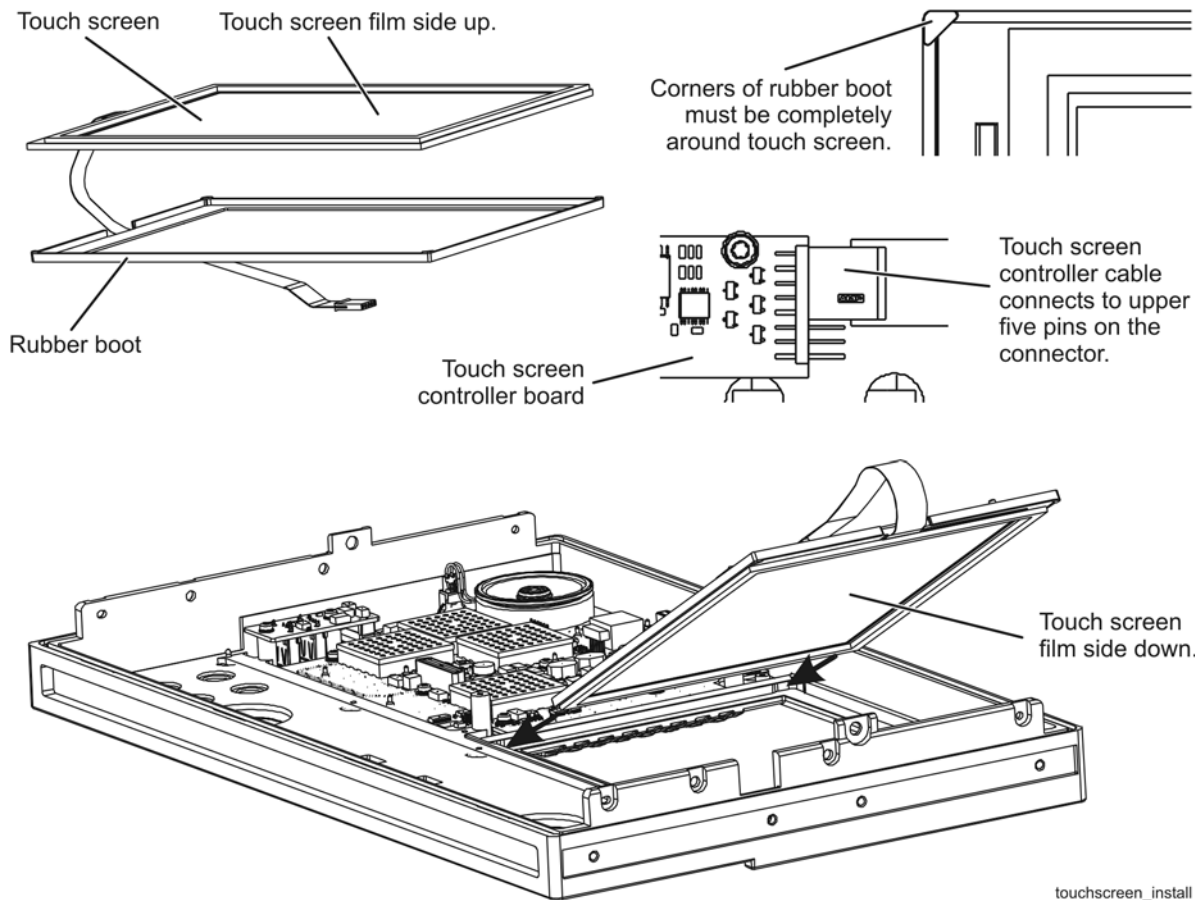

---

## Removing and Replacing the A4 Power Supply Assembly

### Tools Required

- T-10 TORX driver (set to 9 in-lb)
- T-20 TORX driver (set to 21 in-lb)
- ESD grounding wrist strap

### Removal Procedure

Refer to [Figure 7-6](#) for this procedure.

1. Disconnect the power cord.
2. Remove the outer and inner covers. Refer to [“Removing the Covers” on page 7-6](#).
3. With a T-10 TORX driver, remove the five screws (item ①) from the power supply assembly.
4. Lift out and remove the A4 power supply assembly.

### Replacement Procedure

1. Reverse the order of the removal procedure.
2. Perform the post-repair adjustments, verifications, and performance tests that pertain to this removal procedure. Refer to [Table 7-2 on page 7-82](#).



Figure 7-6 A4 Power Supply Assembly Removal

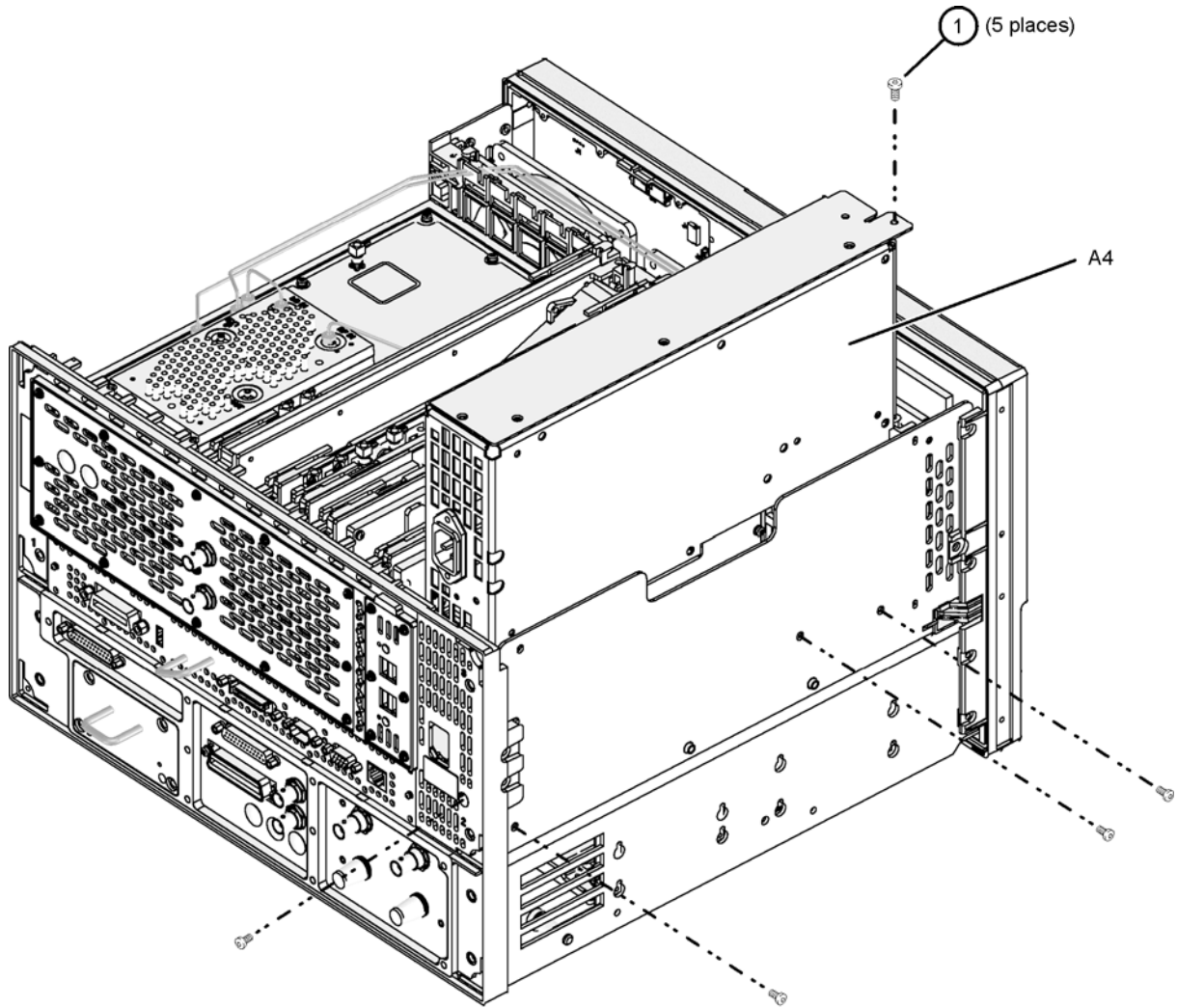

st538b

---

## Removing and Replacing the A6, A8, A9, and A10 Boards

### Tools Required

- T-10 TORX driver (set to 9 in-lb)
- T-20 TORX driver (set to 21 in-lb)
- ESD grounding wrist strap

### Removal Procedure

Refer to [Figure 7-7](#) for this procedure.

1. Disconnect the power cord.
2. Remove the outer and inner covers. Refer to [“Removing the Covers” on page 7-6](#).
3. With a T-10 TORX driver, remove the two brackets that secure cables to the top of the midweb.
4. Identify the board you want to remove and disconnect any cables that are attached to it.
5. Lift the two extractors (item ①), located at each end of the board.

---

**NOTE** Before removing the board completely, check the bottom of the board for any attached cables.

---

6. While holding on to the extractors, slide the board out of the slot and remove it from the analyzer.

### Replacement Procedure

1. Reverse the order of the removal procedure.
2. Perform the post-repair adjustments, verifications, and performance tests that pertain to this removal procedure. Refer to [Table 7-2 on page 7-82](#).

**Figure 7-7** A6, A8, A9, and A10 Board Assemblies Removal

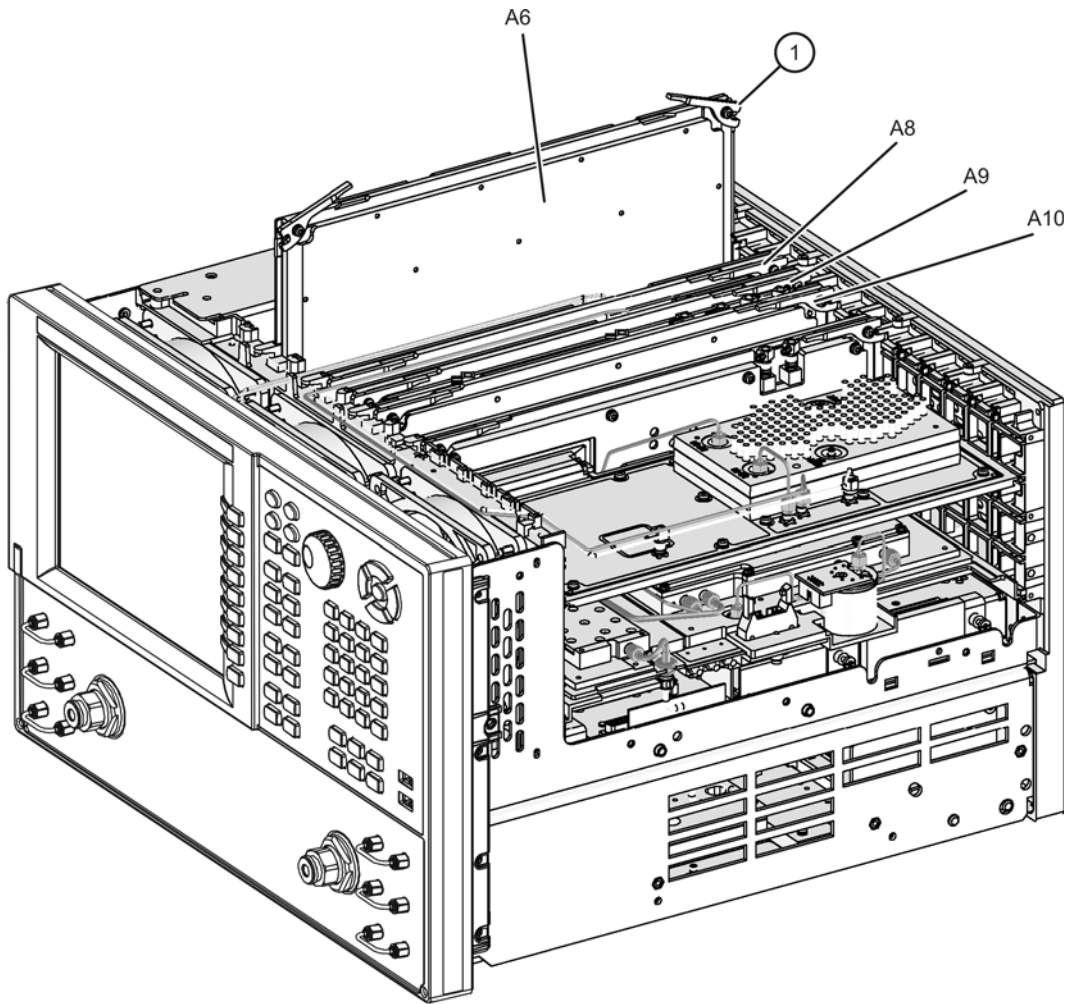

st539b\_new

---

## Removing and Replacing the A11 Phase Lock Board

### Tools Required

- T-10 TORX driver (set to 9 in-lb)
- T-20 TORX driver (set to 21 in-lb)
- ESD grounding wrist strap

### Removal Procedure

Refer to [Figure 7-8](#) for this procedure.

1. Disconnect the power cord.
2. Remove the outer and inner covers. Refer to [“Removing the Covers” on page 7-6](#).
3. With a T-10 TORX driver, remove the two brackets that secure cables to the top of the midweb.
4. With a T-10 TORX driver, remove the two screws (item ①) from the top of the A11 phase lock board.
5. Remove the A13 frequency offset receiver assembly, if present. Refer to [“Removing and Replacing the A13 Frequency Offset Receiver Assembly” on page 7-24](#).
6. Disengage the A12 source 20 from the A11 connector and slide the A12 partially out of the analyzer. Refer to [“Removing and Replacing the A12 Source 20” on page 7-22](#).
7. Disconnect any flexible cables that are attached to the A11 phase lock board.
8. Lift the two extractors (item ②) located at each end of the board.
9. While holding on to the extractors, lift the A11 phase lock board out of the analyzer.

### Replacement Procedure

1. Reverse the order of the removal procedure.
2. Perform the post-repair adjustments, verifications, and performance tests that pertain to this removal procedure. Refer to [Table 7-2 on page 7-82](#).

Figure 7-8 A11 Phase Lock Board Removal

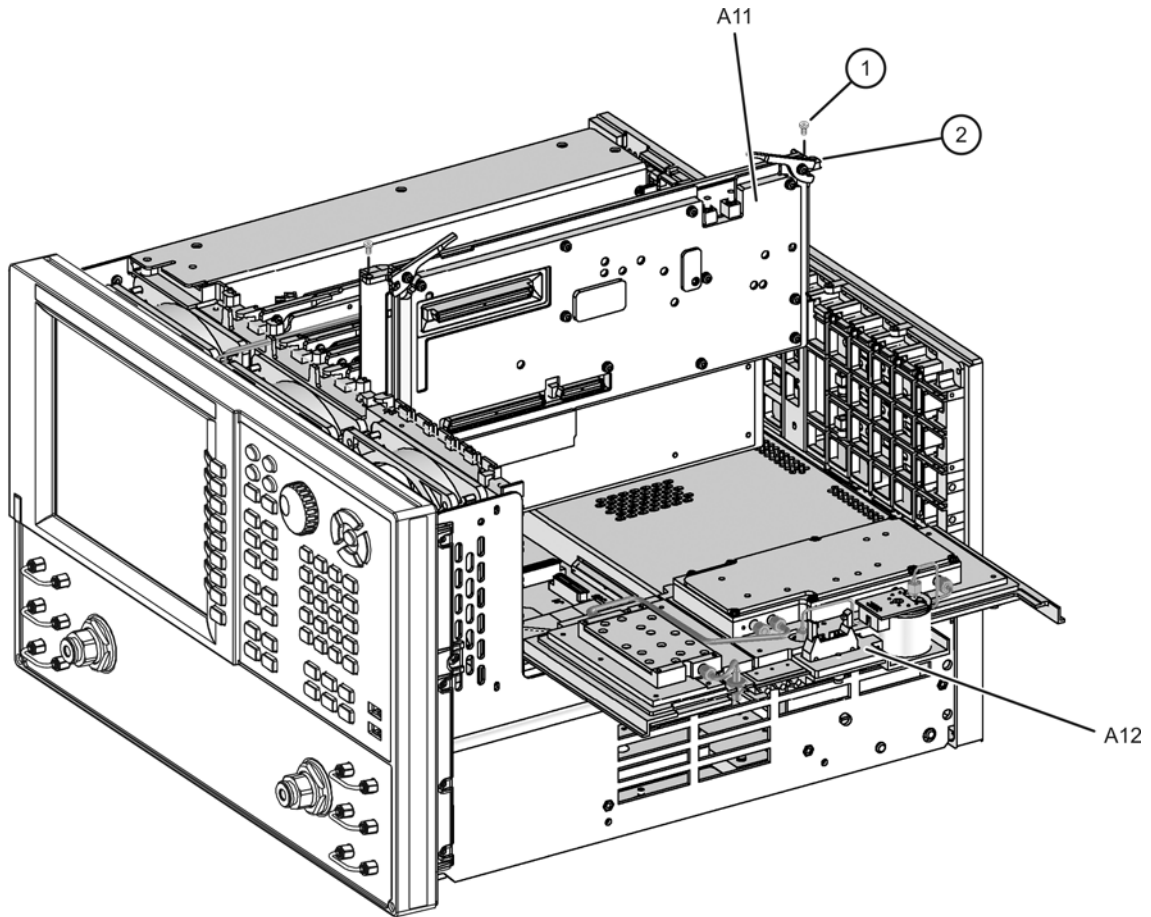

st540b\_new

---

## Removing and Replacing the A12 Source 20

### Tools Required

- T-10 TORX driver (set to 9 in-lb)
- T-20 TORX driver (set to 21 in-lb)
- 5/16-inch open-end torque wrench (set to 10 in-lb)
- ESD grounding wrist strap

### Removal Procedure

Refer to [Figure 7-9](#) for this procedure.

1. Disconnect the power cord.
2. Remove the outer and inner covers. Refer to [“Removing the Covers”](#) on page 7-6.
3. Remove the A13 (Option 080) frequency offset receiver assembly, if present. Refer to [“Removing and Replacing the A13 Frequency Offset Receiver Assembly”](#) on page 7-24.
4. With a 5/16-inch torque wrench, disconnect the semirigid cable (item ①) from the bottom of the A12 source 20.

---

**CAUTION** To avoid damage to the semirigid cable (item ①), pull down on the cable from the bottom of the analyzer to move it away while sliding out the A12 source 20. The cable has some spring to it and the RF pin could be damaged by the A12 source 20.

---

5. Disengage the A12 source 20 from the A11 connector and slide out of the analyzer. Observe the **CAUTION** above.

### Replacement Procedure

1. Reverse the order of the removal procedure.
2. Perform the post-repair adjustments, verifications, and performance tests that pertain to this removal procedure. Refer to [Table 7-2](#) on page 7-82.

Figure 7-9 A12 Source 20 Removal

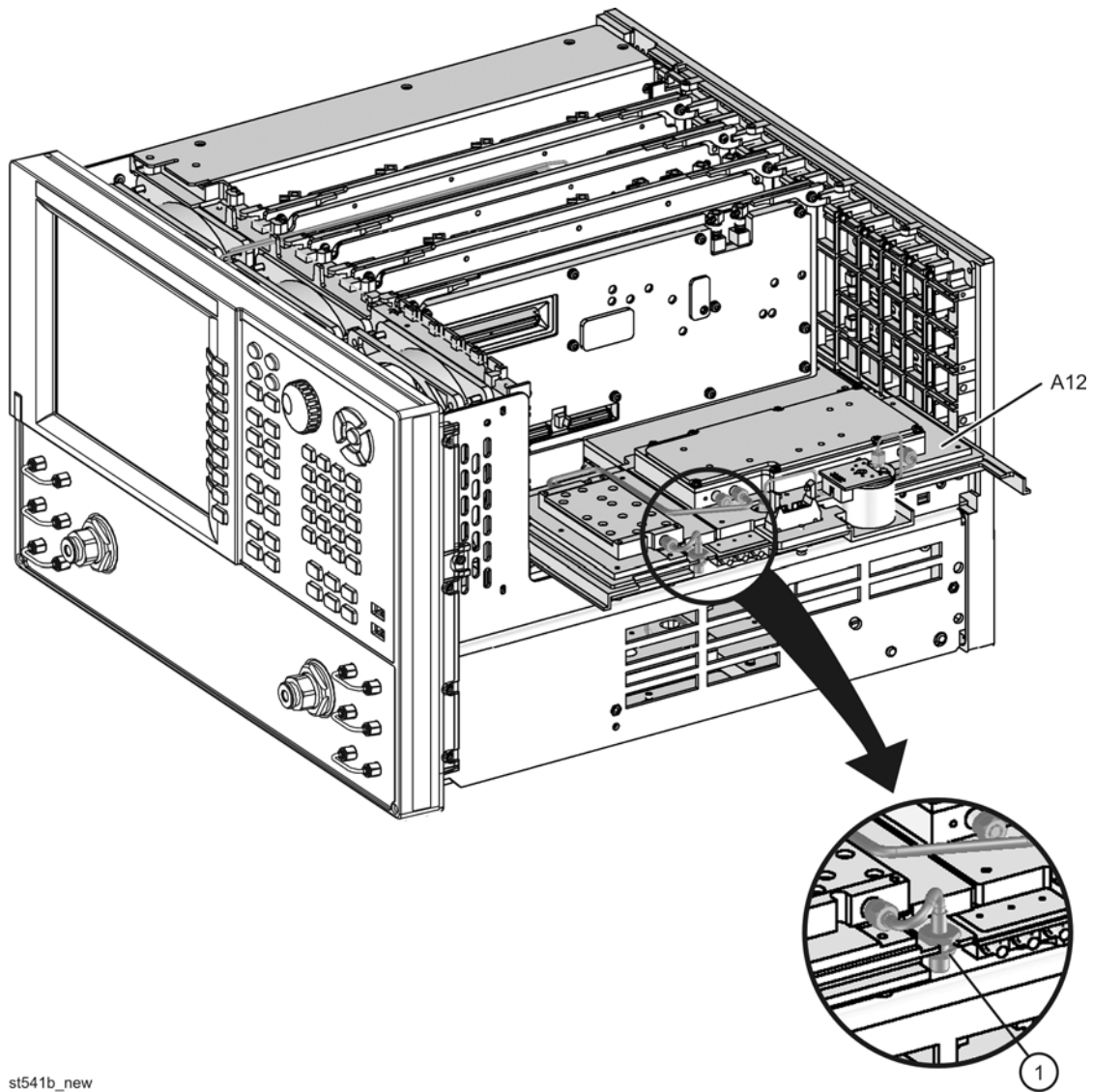

st541b\_new

---

## Removing and Replacing the A13 Frequency Offset Receiver Assembly

### Tools Required

- T-10 TORX driver (set to 9 in-lb)
- T-20 TORX driver (set to 21 in-lb)
- 5/16-inch open-end torque wrench (set to 10 in-lb)
- ESD grounding wrist strap

### Removal Procedure

Refer to [Figure 7-9](#) for this procedure.

1. Disconnect the power cord.
2. Remove the outer and inner covers. Refer to “[Removing the Covers](#)” on page 7-6.
3. With a 5/16-inch torque wrench, disconnect the three semirigid cables (item ①) and flexible cable (item ②) from the top of the A13 frequency offset receiver assembly.

---

**CAUTION** Be careful not to damage the center pins of the semirigid cables. Some flexing of the cables is necessary to remove the assembly. Do not over-bend the semirigid cables.

---

4. Disengage the A13 frequency offset receiver assembly from the A11 connector and slide out of the analyzer. Observe the **CAUTION** above.

### Replacement Procedure

1. Reverse the order of the removal procedure.
2. Perform the post-repair adjustments, verifications, and performance tests that pertain to this removal procedure. Refer to [Table 7-2 on page 7-82](#).



Figure 7-10 A13 Frequency Offset Receiver Assembly Removal

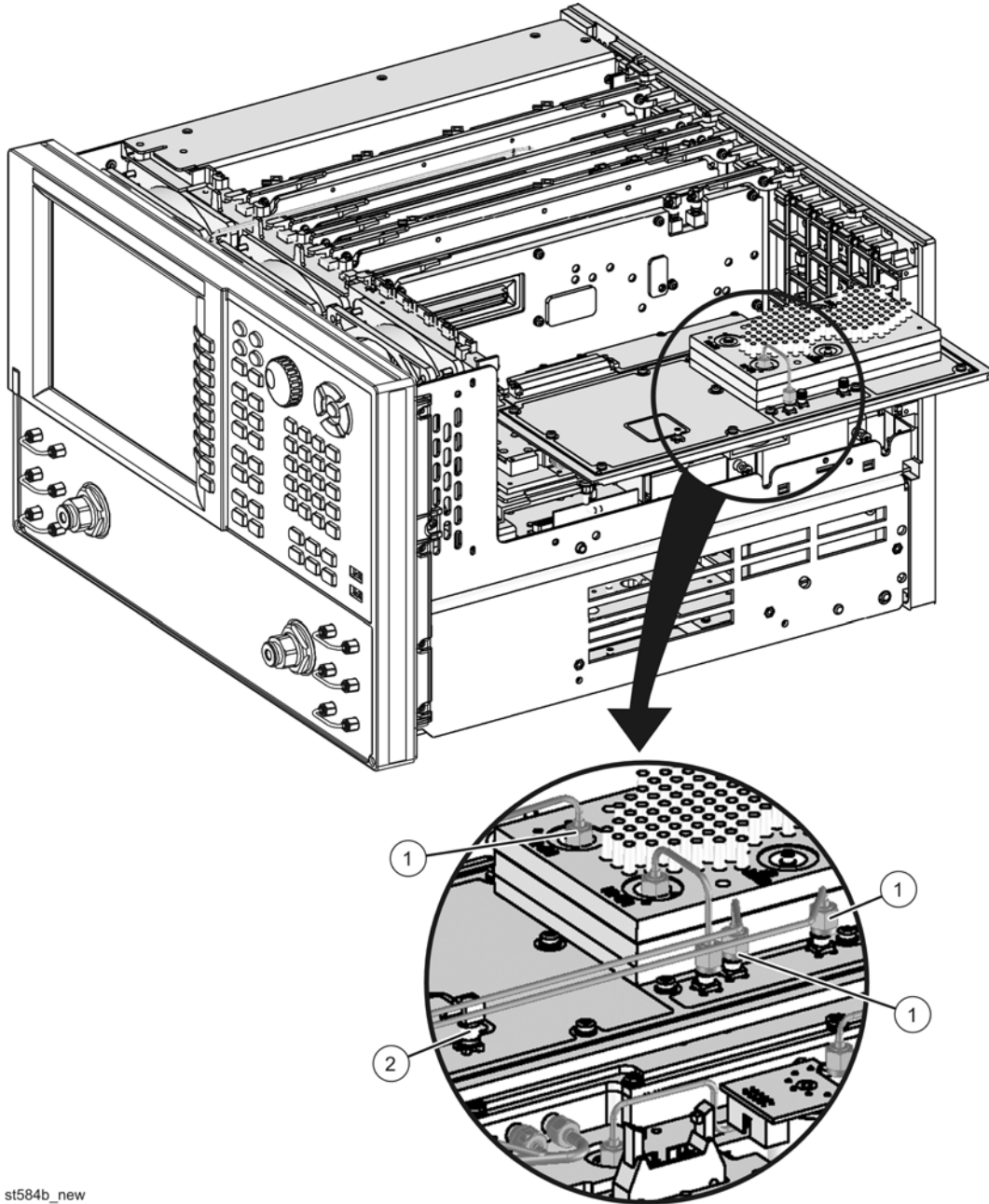

st584b\_new

---

## Removing and Replacing the A14 System Motherboard

### Tools Required

- T-10 TORX driver (set to 9 in-lb)
- T-20 TORX driver (set to 21 in-lb)
- 5/16-inch open-end torque wrench (set to 10 in-lb)
- ESD grounding wrist strap

### Removal Procedure

Refer to [Figure 7-11](#) for this procedure.

1. Disconnect the power cord.
2. Remove the outer and inner covers. Refer to [“Removing the Covers”](#) on page 7-6.
3. Remove the front panel assembly. Refer to [“Removing and Replacing the Front Panel Assembly”](#) on page 7-10.
4. Remove the A12 source 20. Refer to [“Removing and Replacing the A12 Source 20”](#) on page 7-22.
5. Remove the A13 (Option 080) frequency offset receiver assembly, if present. Refer to [“Removing and Replacing the A13 Frequency Offset Receiver Assembly”](#) on page 7-24.
6. Remove the A11 phase lock board. Refer to [“Removing and Replacing the A11 Phase Lock Board”](#) on page 7-20.
7. Remove the A4 power supply assembly. Refer to [“Removing and Replacing the A4 Power Supply Assembly”](#) on page 7-16.
8. Remove the card cage boards (A6, A8, and A10). Remove A9 (Option 080), if present. Refer to [“Removing and Replacing the A6, A8, A9, and A10 Boards”](#) on page 7-18.
9. Remove the A15 CPU board. Refer to [“Removing and Replacing the A15 CPU Board”](#) on page 7-28.
10. Remove the Midweb. Refer to [“Removing and Replacing the Midweb and the B1 Fan”](#) on page 7-76.
11. Remove the ribbon cable clamp (item ⑥) by removing the attachment screw (item ⑤). Set the cable clamp aside for reinstallation later.
12. Disconnect the front panel ribbon cable (item ①), the test set motherboard ribbon cable (item ②), and the USB hub assembly cable (item ③) from the A14 system motherboard.
13. Remove the remaining three screws (item ④) that secure the A14 system motherboard.
14. Lift the A14 system motherboard out of the analyzer.

### Replacement Procedure

1. Reverse the order of the removal procedure.
2. Perform the post-repair adjustments, verifications, and performance tests that pertain to this removal procedure. Refer to [Table 7-2](#) on page 7-82.

**Figure 7-11 A14 System Motherboard Removal**

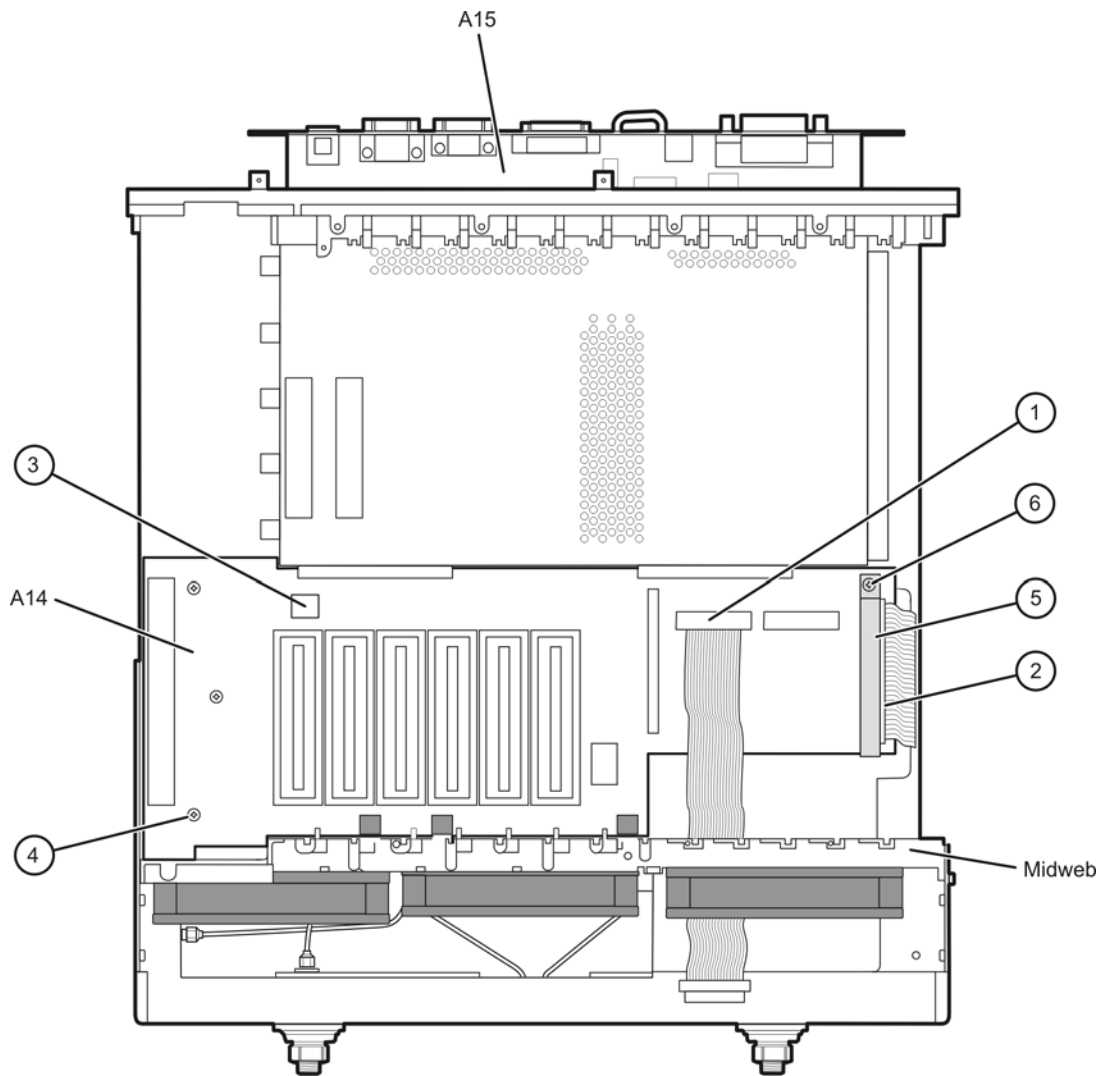

st542b\_new

---

## Removing and Replacing the A15 CPU Board

### Tools Required

- T-10 TORX driver (set to 9 in-lb)
- T-20 TORX driver (set to 21 in-lb)
- ESD grounding wrist strap

### Removal Procedure

Refer to [Figure 7-12](#) for this procedure.

1. Disconnect the power cord.
2. Disconnect the hard disk drive assembly (HDDA) ribbon cable and interface board from the A15 CPU board by removing the two screws (item ①).
3. Disengage the A6 SPAM board from the A15 CPU board by performing the following steps.
  - a. Lift the two extractors located at each end of the board.
  - b. While holding onto the extractors, lift the board halfway out of the slot.
  - c. Let the extractors drop to their normal position.
  - d. Lower the board into the slot.The board should now rest above its normal seated position.
4. With a T-10 TORX driver, remove the 14 screws (item ②) from the rear panel of the A15 CPU board.
5. Gently pull on the finger grip (item ③) to disengage the A15 CPU board from the analyzer.
6. Slide the A15 CPU board out of the analyzer.

### Replacement Procedure

**NOTE:** If not already done, install a jumper between pins 9 and 10 on connector J11. See the following

illustration for the J11 pin configuration. There should already be a jumper between pins 5 and 6.

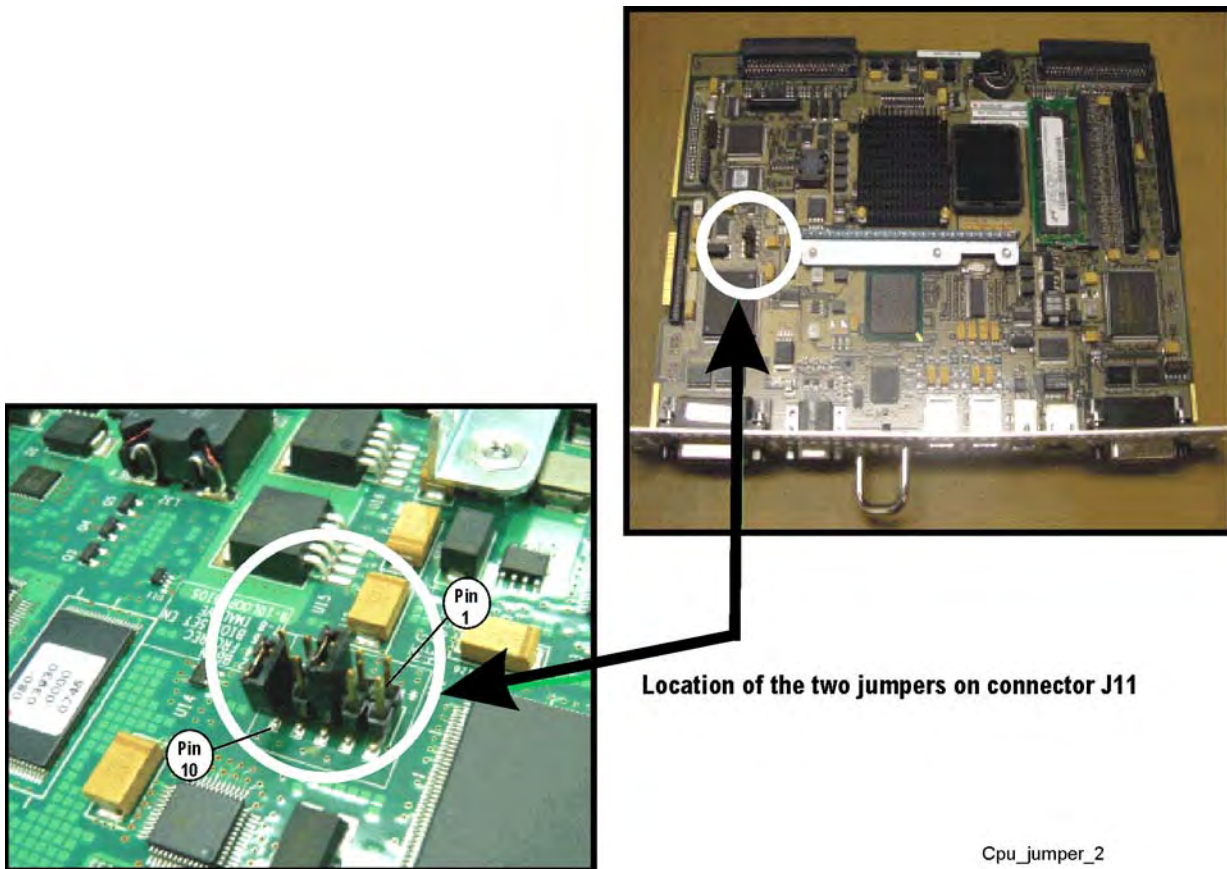

1. Reverse the order of the removal procedure.
2. Perform the post-repair adjustments, verifications, and performance tests that pertain to this removal procedure. Refer to [Table 7-2 on page 7-82](#).

Figure 7-12 A15 CPU Board Removal

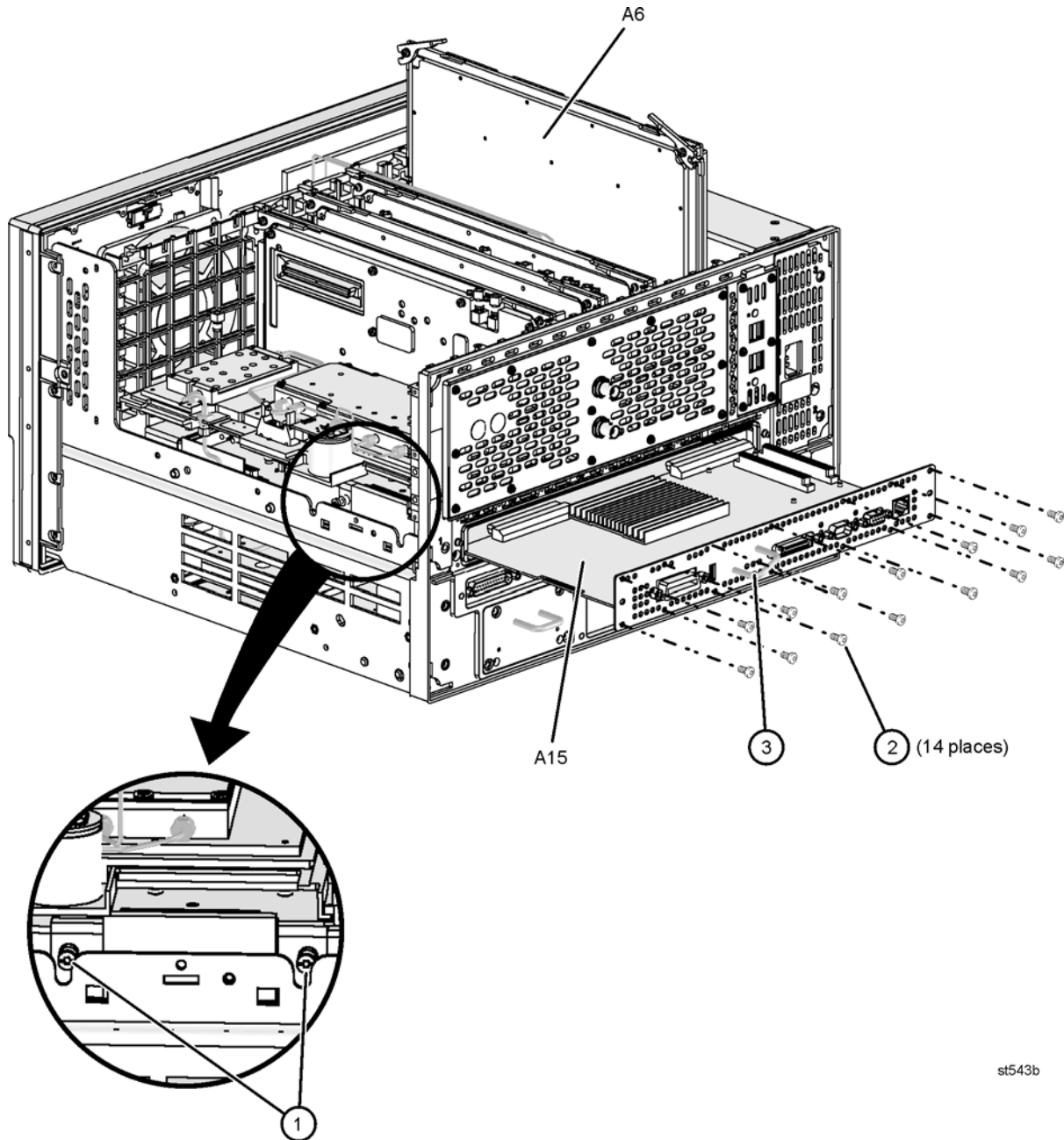

st543b



---

## Removing and Replacing the A16 Test Set Motherboard

### Tools Required

- T-10 TORX driver (set to 9 in-lb)
- T-20 TORX driver (set to 21 in-lb)
- 5/16-inch open-end torque wrench (set to 10 in-lb)
- ESD grounding wrist strap

### Removal Procedure

Refer to [Figure 7-13](#) for this procedure.

1. Disconnect the power cord.
2. Remove the outer covers. Refer to [“Removing the Covers” on page 7-6](#). Position the analyzer bottom side up and raise the receiver deck as shown. Refer to [“Raising and Removing the Receiver Deck” on page 7-8](#) if necessary.
3. Remove the A21 SOMA 50 (E8363C and E8364C) or RF cable W1 (E8362C). Refer to [“Removing and Replacing the A21 SOMA 50 \(E8363C and E8364C Only\)” on page 7-42](#).
4. Remove the A41 hard disk drive. Refer to [“Removing and Replacing the A41 Hard Disk Drive \(HDD\)” on page 7-62](#).
5. Remove the A41 hard disk drive shield by loosening two attachment screws using a T-10 TORX driver. These screws are accessible through holes in the side of the chassis.
6. Disconnect the ribbon cables (item ①) from the A16 test set motherboard.
7. Disconnect the wrapped-wire cables (item ②) from the A16 test set motherboard.
8. Release the flexible RF cables from the cable clamp (item ③). Release the receiver deck by pulling the latch pin (item ④), and move the entire receiver deck out of the way, with the cables attached.
9. With a T-10 TORX driver, remove the following screws:
  - Nine screws (item ⑤) from the rear panel.
  - Four screws (item ⑥) from the A16 test set motherboard.
10. Slide the A16 test set motherboard toward the front of the instrument to release the locking pins (item ⑦), then lift the motherboard and remove it from the analyzer.

### Replacement Procedure

1. Reverse the order of the removal procedure.

Note: When replacing the attachment screws, install the four screws in the motherboard first, leaving them loose until the nine rear panel screws have been tightened.

2. Perform the post-repair adjustments, verifications, and performance tests that pertain to this removal procedure. Refer to [Table 7-2 on page 7-82](#).



Figure 7-13 A16 Test Set Motherboard Removal

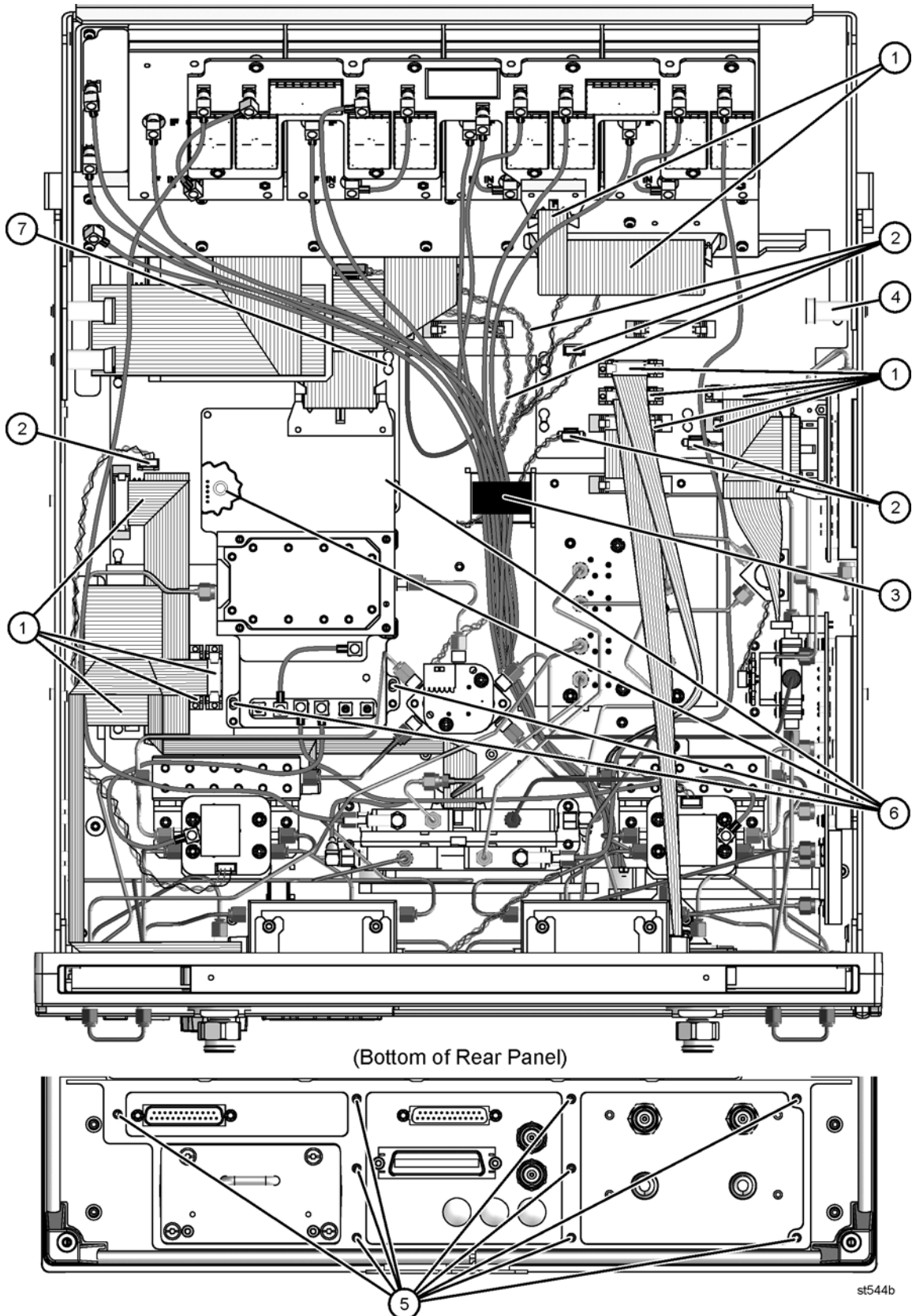

st544b

---

## Removing and Replacing the A17 LOMA 10

### Tools Required

- T-10 TORX driver (set to 9 in-lb)
- T-20 TORX driver (set to 21 in-lb)
- 5/16-inch open-end torque wrench (set to 10 in-lb)
- ESD grounding wrist strap

### Removal Procedure

Refer to [Figure 7-14](#) for this procedure.

1. Disconnect the power cord.
2. Remove the outer cover. Refer to “[Removing the Covers](#)” on page 7-6. Position the analyzer bottom side up and raise the receiver deck as shown. Refer to “[Raising and Removing the Receiver Deck](#)” on page 7-8 if necessary.
3. With a 5/16-inch torque wrench, disconnect the three semirigid cables (item ①) from the A17 LOMA 10.
4. Disconnect the ribbon cable (item ②) at the A17 LOMA 10.
5. With a T-10 TORX driver, remove the four mounting screws (item ③) from the side of the analyzer.

---

**CAUTION** Be careful not to damage the center pins of the semirigid cables. Some flexing of the cables is necessary to remove the assembly. Do not over-bend the semirigid cables.

---

6. Remove the A17 LOMA 10 from the analyzer. Observe the **CAUTION** above.

### Replacement Procedure

1. Reverse the order of the removal procedure.
2. Perform the post-repair adjustments, verifications, and performance tests that pertain to this removal procedure. Refer to [Table 7-2 on page 7-82](#).

Figure 7-14 A17 LOMA 10 Removal

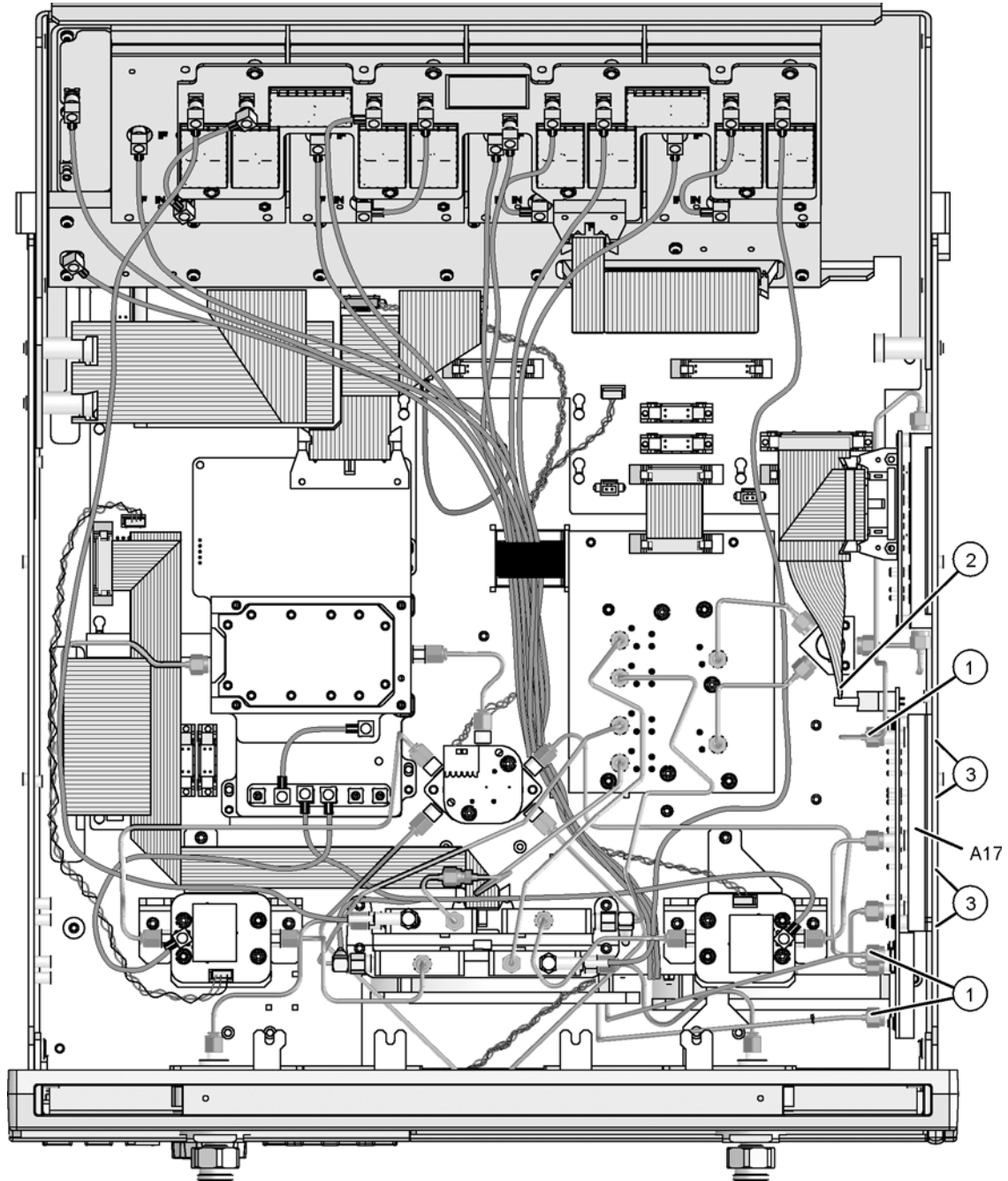

st545b

---

## Removing and Replacing the A18 MA 20

### Tools Required

- T-10 TORX driver (set to 9 in-lb)
- T-20 TORX driver (set to 21 in-lb)
- 5/16-inch open-end torque wrench (set to 10 in-lb)
- ESD grounding wrist strap

### Removal Procedure

Refer to [Figure 7-14](#) for this procedure.

1. Disconnect the power cord.
2. Remove the outer cover. Refer to “[Removing the Covers](#)” on page 7-6. Position the analyzer bottom side up and raise the receiver deck as shown. Refer to “[Raising and Removing the Receiver Deck](#)” on page 7-8 if necessary.
3. With a 5/16-inch torque wrench, disconnect the two semirigid cables (item ①) from the A18 MA 20. It may be necessary to remove these cables completely to allow the A18 MA 20 to be removed from the analyzer.
4. Disconnect the ribbon cable (item ②) at the A18 MA 20.
5. With a T-10 TORX driver, remove the four mounting screws (item ③) from the side of the analyzer.

---

**CAUTION** Be careful not to damage the center pins of the semirigid cables. Some flexing of the cables is necessary to remove the assembly. Do not over-bend the semirigid cables.

---

6. Remove the A18 MA 20 from the analyzer. Observe the **CAUTION** above.

### Replacement Procedure

1. Reverse the order of the removal procedure.
2. Perform the post-repair adjustments, verifications, and performance tests that pertain to this removal procedure. Refer to [Table 7-2 on page 7-82](#).

Figure 7-15 A18 MA 20 Removal

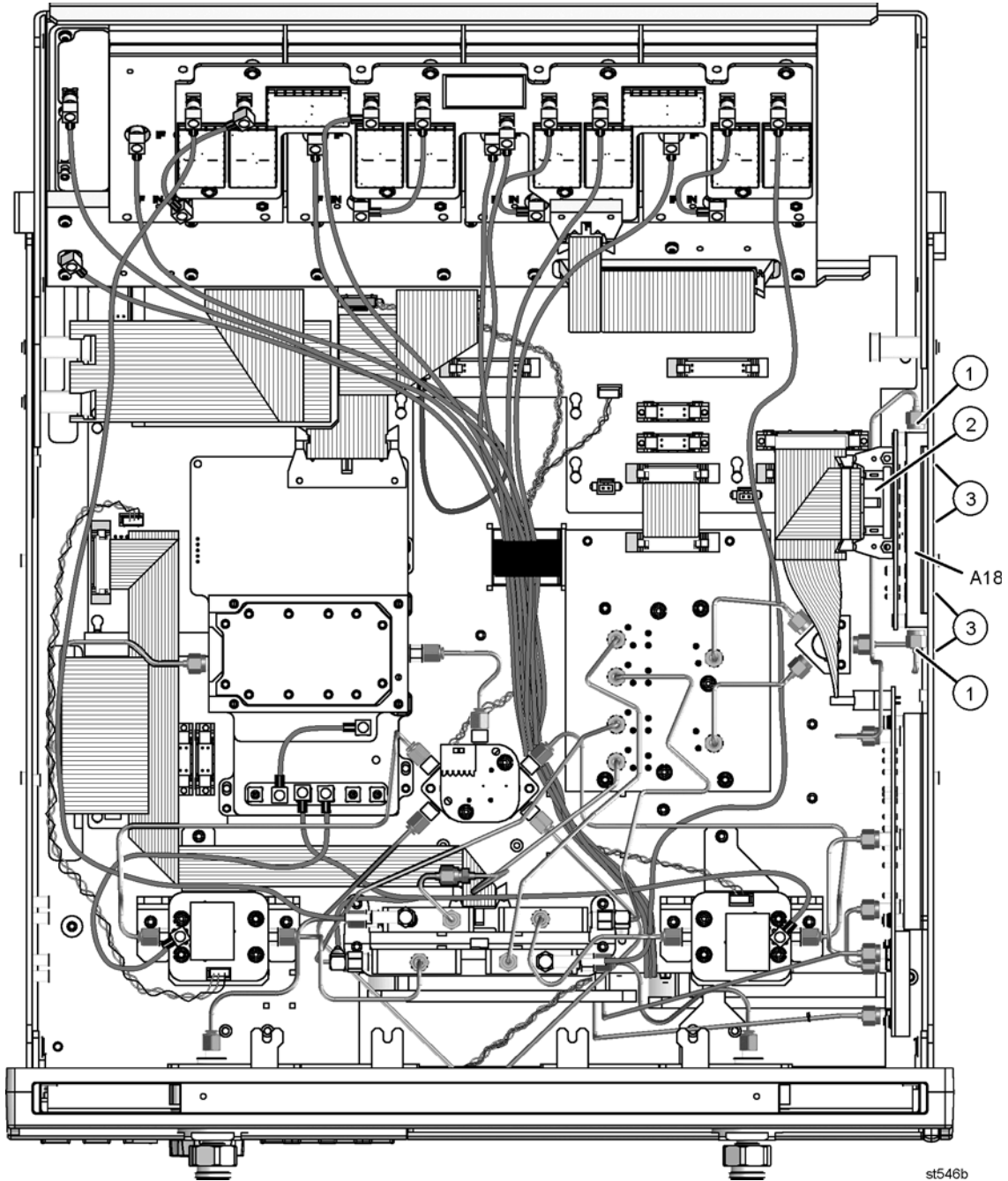

---

## Removing and Replacing the A19 Splitter

### Tools Required

- T-10 TORX driver (set to 9 in-lb)
- T-20 TORX driver (set to 21 in-lb)
- 5/16-inch open-end torque wrench (set to 10 in-lb)
- ESD grounding wrist strap

### Removal Procedure

Refer to [Figure 7-14](#) for this procedure.

1. Disconnect the power cord.
2. Remove the outer cover. Refer to [“Removing the Covers” on page 7-6](#). Position the analyzer bottom side up and raise the receiver deck as shown. Refer to [“Raising and Removing the Receiver Deck” on page 7-8](#) if necessary.
3. With a 5/16-inch torque wrench, disconnect the three semirigid cables (item ①) from the A19 splitter.
4. With a T-10 TORX driver, remove the two mounting screws (item ②).

---

**CAUTION** Be careful not to damage the center pins of the semirigid cables. Some flexing of the cables is necessary to remove the assembly. Do not over-bend the semirigid cables.

---

5. Remove the A19 splitter from the analyzer. Observe the **CAUTION** above.

### Replacement Procedure

1. Reverse the order of the removal procedure.
2. Perform the post-repair adjustments, verifications, and performance tests that pertain to this removal procedure. Refer to [Table 7-2 on page 7-82](#).

Figure 7-16 A19 Splitter Removal

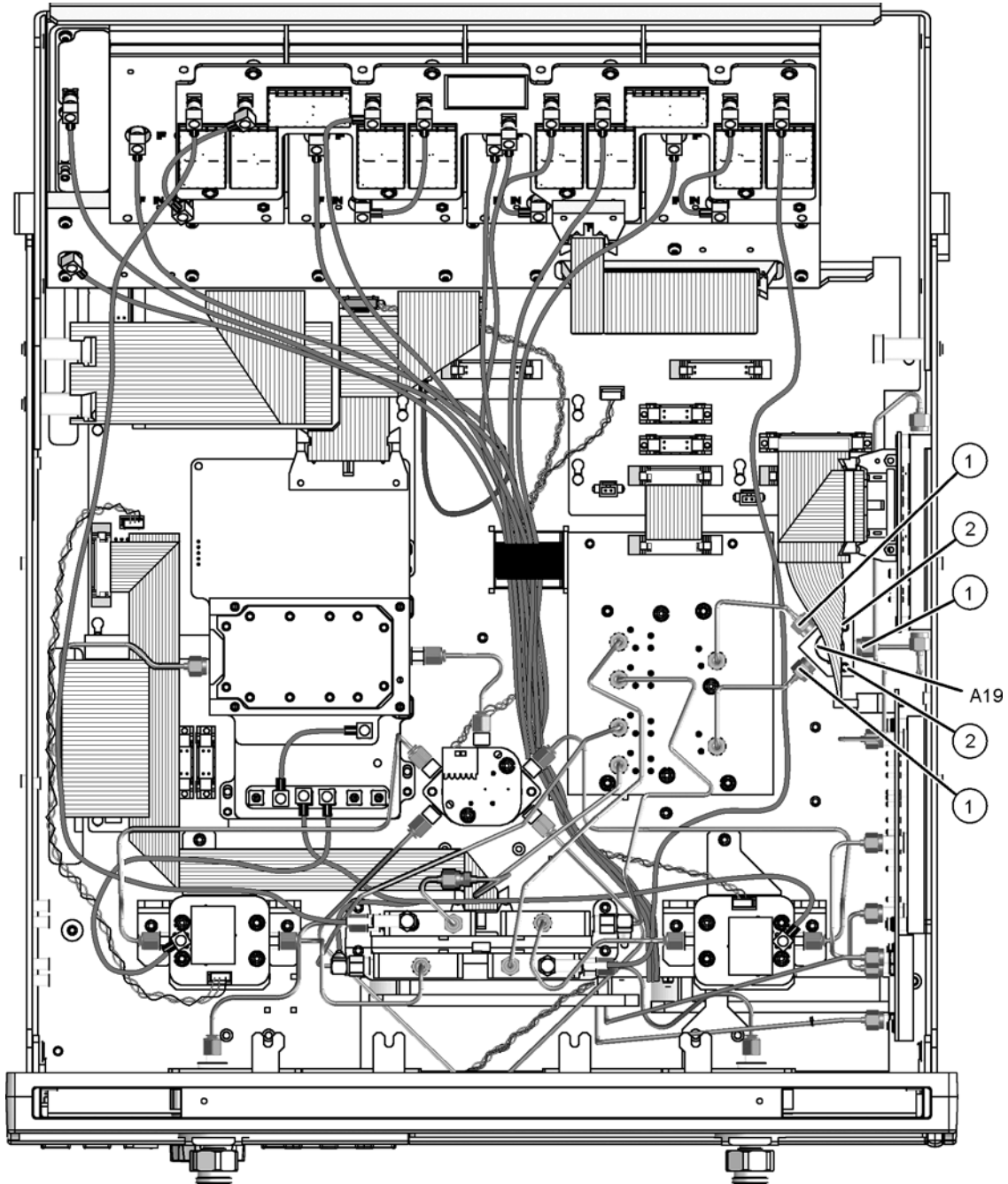

st547b

---

## Removing and Replacing the A20 LODA

### Tools Required

- T-10 TORX driver (set to 9 in-lb)
- T-20 TORX driver (set to 21 in-lb)
- 5/16-inch open-end torque wrench (set to 10 in-lb)
- ESD grounding wrist strap

### Removal Procedure

Refer to [Figure 7-14](#) for this procedure.

1. Disconnect the power cord.
2. Remove the outer cover. Refer to [“Removing the Covers” on page 7-6](#). Position the analyzer bottom side up and raise the receiver deck as shown. Refer to [“Raising and Removing the Receiver Deck” on page 7-8](#) if necessary.
3. With a 5/16-inch torque wrench, disconnect the six semirigid cables (item ①) from the A20 LODA.
4. Disconnect the ribbon cable (item ②) at the A20 LODA.
5. With a T-10 TORX driver, remove the six mounting screws (item ③).

---

**CAUTION** Be careful not to damage the center pins of the semirigid cables. Some flexing of the cables is necessary to remove the assembly. Do not over-bend the semirigid cables.

---

6. Remove the A20 LODA from the analyzer. Observe the **CAUTION** above.

### Replacement Procedure

1. Reverse the order of the removal procedure.
2. Perform the post-repair adjustments, verifications, and performance tests that pertain to this removal procedure. Refer to [Table 7-2 on page 7-82](#).



Figure 7-17 A20 LODA Removal

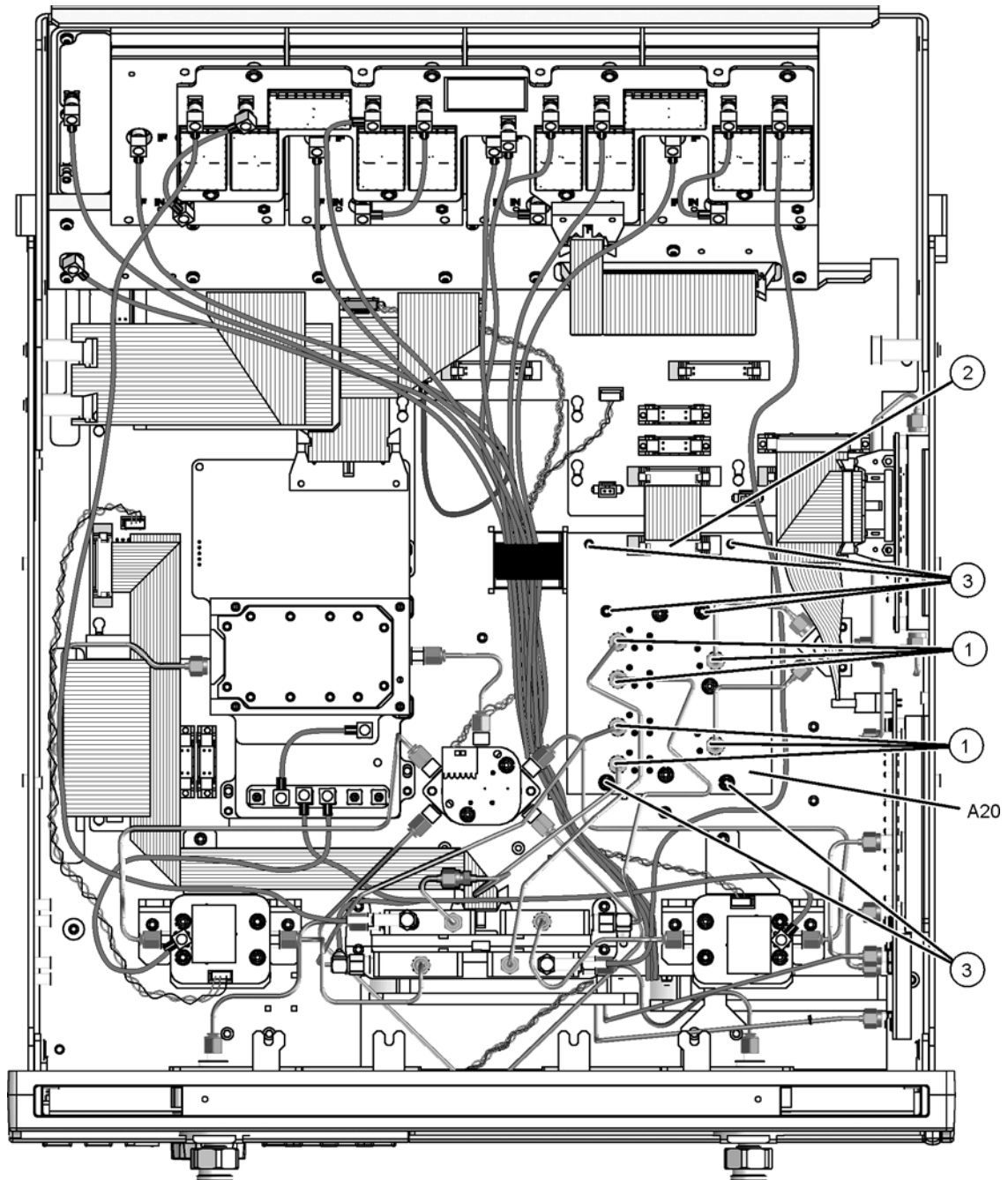

st548b

---

## Removing and Replacing the A21 SOMA 50 (E8363C and E8364C Only)

### Tools Required

- T-10 TORX driver (set to 9 in-lb)
- T-20 TORX driver (set to 21 in-lb)
- 5/16-inch open-end torque wrench (set to 10 in-lb)
- ESD grounding wrist strap

### Removal Procedure

Refer to [Figure 7-14](#) for this procedure.

1. Disconnect the power cord.
2. Remove the outer cover. Refer to [“Removing the Covers” on page 7-6](#). Position the analyzer bottom side up and raise the receiver deck as shown. Refer to [“Raising and Removing the Receiver Deck” on page 7-8](#) if necessary.
3. With a 5/16-inch torque wrench, disconnect the two semirigid cables (item ①) from the A21 SOMA 50.
4. Disconnect the flexible cable (item ②) from the A21 SOMA 50.
5. Disconnect the ribbon cable (item ③) at the A21 SOMA 50.
6. With a T-10 TORX driver, remove the four mounting screws (item ④).

---

**CAUTION** Be careful not to damage the center pins of the semirigid cables. Some flexing of the cables is necessary to remove the assembly. Do not over-bend the semirigid cables.

---

7. Remove the A21 SOMA 50 from the analyzer. Observe the **CAUTION** above.

### Replacement Procedure

1. Reverse the order of the removal procedure.
2. Perform the post-repair adjustments, verifications, and performance tests that pertain to this removal procedure. Refer to [Table 7-2 on page 7-82](#).

Figure 7-18 A21 SOMA 50 Removal (E8363C and E8364C Only)

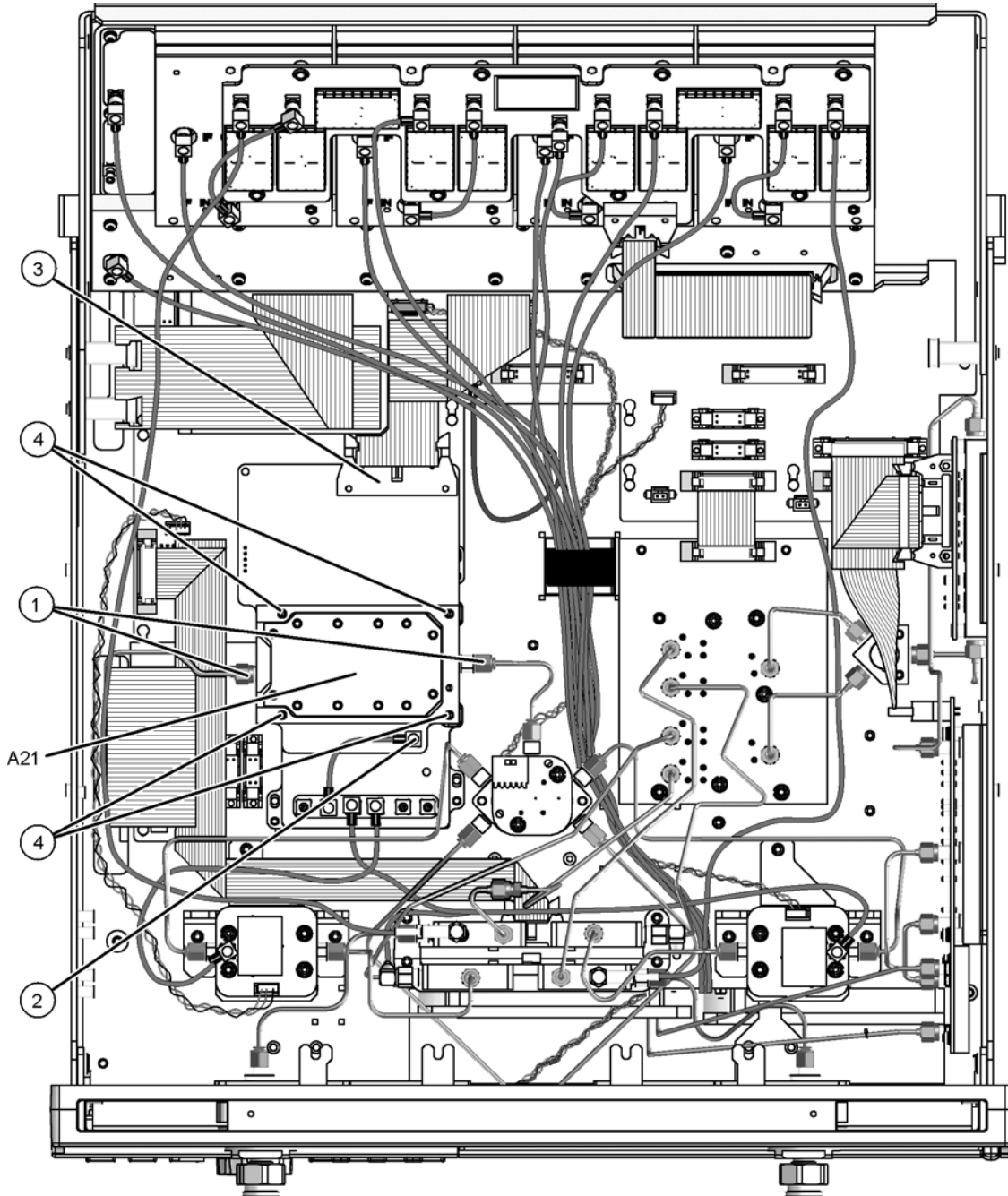

st549b

---

## Removing and Replacing the A22 Switch Splitter

### Tools Required

- T-10 TORX driver (set to 9 in-lb)
- T-20 TORX driver (set to 21 in-lb)
- 5/16-inch open-end torque wrench (set to 10 in-lb)
- ESD grounding wrist strap

### Removal Procedure

Refer to [Figure 7-19](#) for this procedure.

1. Disconnect the power cord.
2. Remove the outer cover. Refer to [“Removing the Covers” on page 7-6](#). Position the analyzer bottom side up and raise the receiver deck as shown. Refer to [“Raising and Removing the Receiver Deck” on page 7-8](#) if necessary.
3. Disconnect the stranded switch control cable (item ①) from the A22 switch splitter.
4. With a 5/16-inch torque wrench, disconnect the five semirigid cables (item ②).
5. With a T-10 TORX driver, remove the four mounting screws (item ③).

---

**CAUTION** Be careful not to damage the center pins of the semirigid cables. Some flexing of the cables is necessary to remove the assembly. Do not over-bend the semirigid cables.

---

6. Remove the A22 switch splitter from the analyzer. Observe the **CAUTION** above.

### Replacement Procedure

1. Reverse the order of the removal procedure.
2. Perform the post-repair adjustments, verifications, and performance tests that pertain to this removal procedure. Refer to [Table 7-2 on page 7-82](#).

Figure 7-19 A22 Switch Splitter Removal

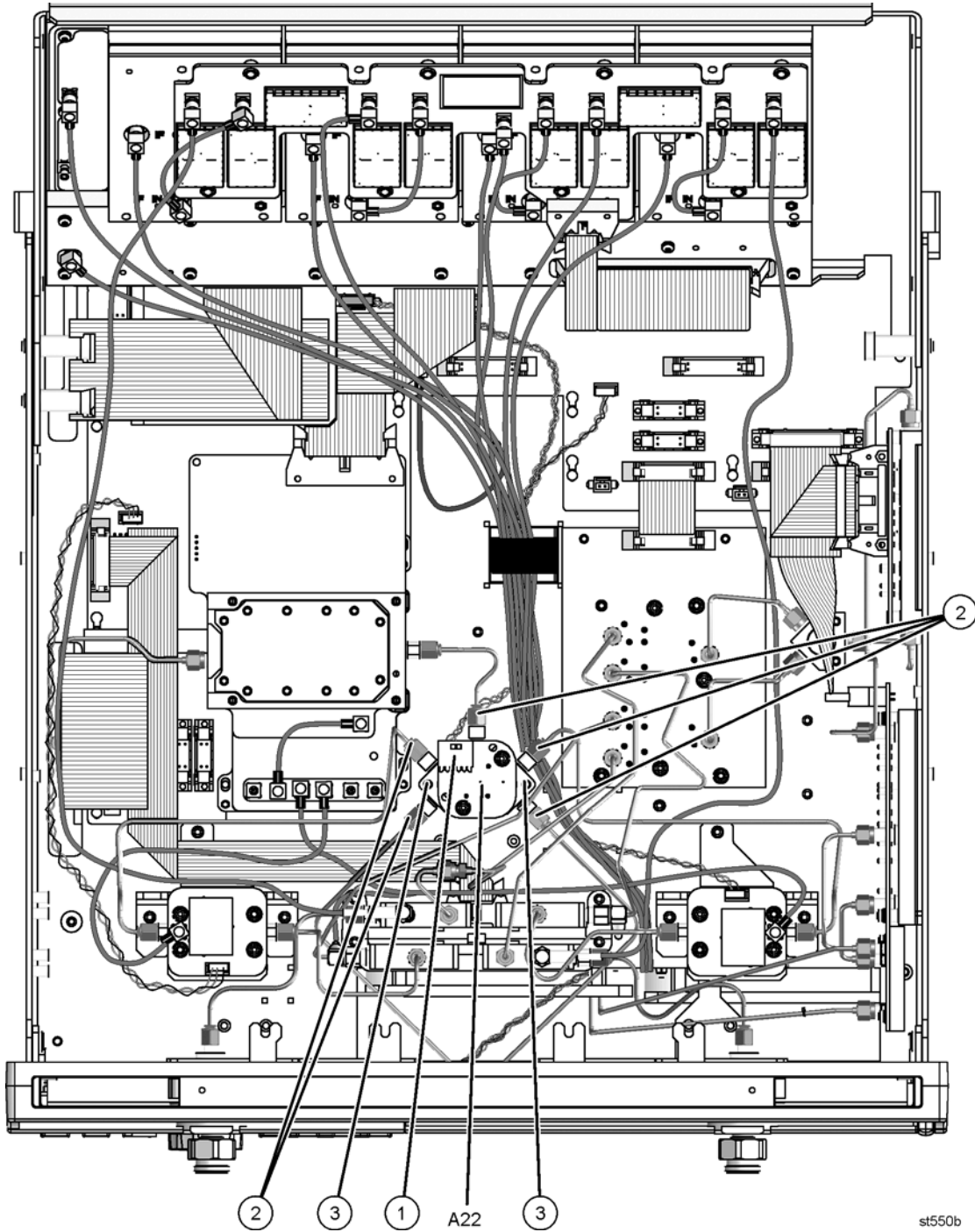

st550b

---

## Removing and Replacing the 30-dB Fixed Attenuators (E8362C only)

### Tools Required

- T-10 TORX driver (set to 9 in-lb)
- T-20 TORX driver (set to 21 in-lb)
- 1/4-inch open-end wrench
- 5/16-inch open-end torque wrench (set to 10 in-lb)
- ESD grounding wrist strap

### Removal Procedure

Refer to [Figure 7-20](#) for this procedure.

1. Disconnect the power cord.
2. Remove the outer cover. Refer to [“Removing the Covers” on page 7-6](#). Position the analyzer bottom side up as shown. It may be convenient to raise the receiver deck to provide better access. If necessary, refer to [“Raising and Removing the Receiver Deck” on page 7-8](#).
3. Identify the fixed attenuator to be removed.
4. Disconnect the two semirigid cables (item ①) from the attenuator:
  - Use a 1/4-inch open-end wrench, adjacent to the connector to be removed, to hold the attenuator in a fixed position.
  - Use a 5/16-inch torque wrench to loosen the cable connector.
  - Repeat for the cable connector at the other end of the attenuator.

---

**CAUTION** Be careful not to damage the center pins of the semirigid cables. Some flexing of the cables is necessary to remove the attenuator. Do not over-bend the semirigid cables.

---

5. Cut the cable tie (item ②), used to secure the attenuator, and remove the attenuator from its holder. Observe the **CAUTION** above.

### Replacement Procedure

1. Reverse the order of the removal procedure.
2. Perform the post-repair adjustments, verifications, and performance tests that pertain to this removal procedure. Refer to [Table 7-2 on page 7-82](#).

Figure 7-20 30-dB Fixed Attenuator Removal (E8362C Only)

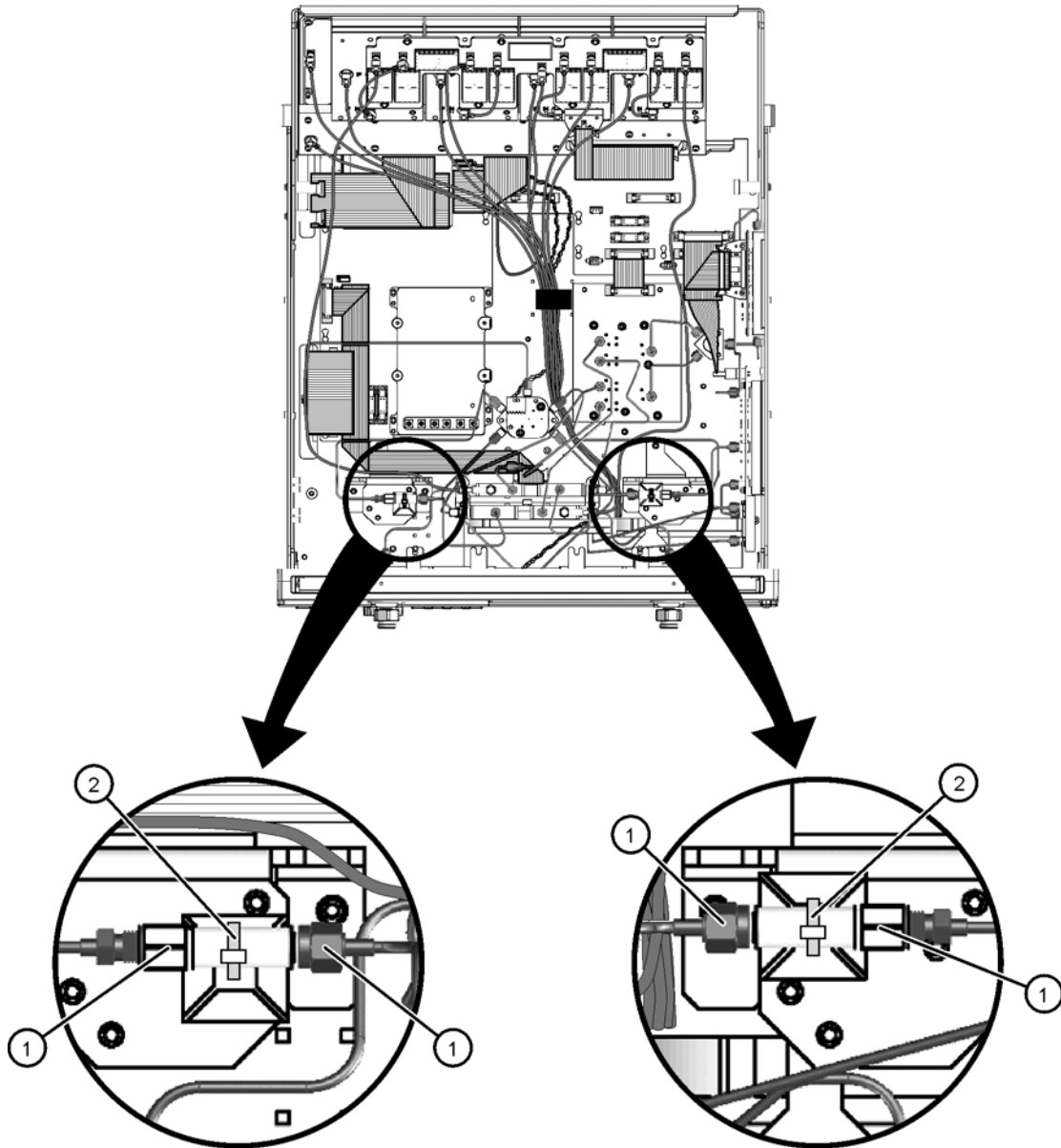

st551b

---

## Removing and Replacing the A23 and A24 Detectors (E8363C and E8364C only)

### Tools Required

- T-10 TORX driver (set to 9 in-lb)
- T-20 TORX driver (set to 21 in-lb)
- 5/16-inch open-end torque wrench (set to 10 in-lb)
- ESD grounding wrist strap

### Removal Procedure

Refer to [Figure 7-21](#) for this procedure.

1. Disconnect the power cord.
2. Remove the outer cover. Refer to [“Removing the Covers” on page 7-6](#). Position the analyzer bottom side up as shown. It may be convenient to raise the receiver deck to provide better access. If necessary, refer to [“Raising and Removing the Receiver Deck” on page 7-8](#).
3. Identify the detector to be removed.
4. Disconnect the stranded control cable (item ①) from the appropriate detector.
5. With a 5/16-inch torque wrench, disconnect the two semirigid cables (item ②) from the detector.
6. Remove the flexible cable (item ③) from the detector.
7. With a T-10 TORX driver, remove the two mounting screws (item ④).

---

**CAUTION** Be careful not to damage the center pins of the semirigid cables. Some flexing of the cables is necessary to remove the assembly. Do not over-bend the semirigid cables.

---

8. Remove the detector from the analyzer. Observe the **CAUTION** above.

### Replacement Procedure

1. Reverse the order of the removal procedure.
2. Perform the post-repair adjustments, verifications, and performance tests that pertain to this removal procedure. Refer to [Table 7-2 on page 7-82](#).



Figure 7-21 A23 and A24 Detectors Removal (E8363C and E8364C Only)

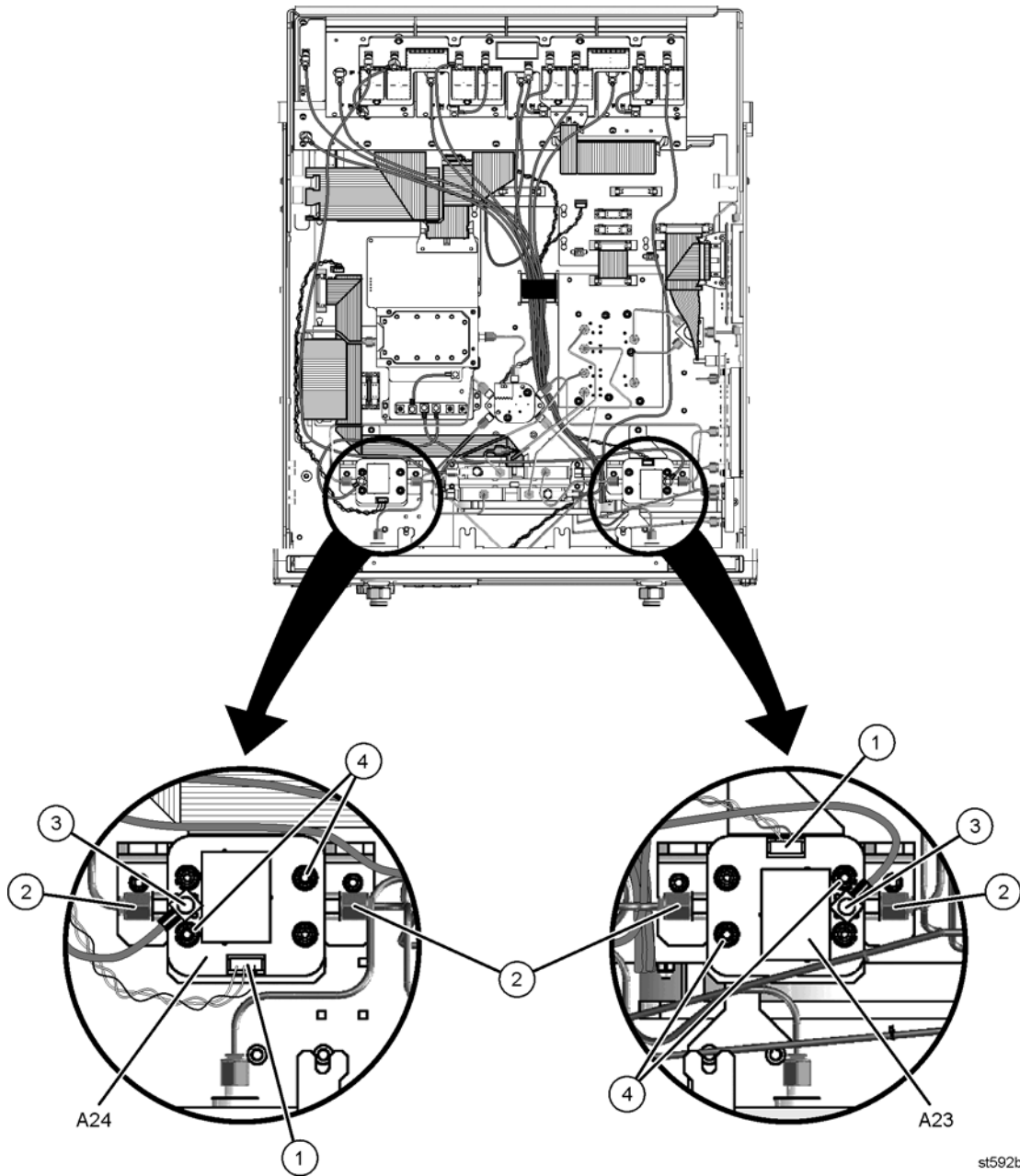

---

## Removing and Replacing the A25 and A26 Test Port Couplers

### Tools Required

- T-10 TORX driver (set to 9 in-lb)
- T-20 TORX driver (set to 21 in-lb)
- 5/16-inch open-end torque wrench (set to 10 in-lb)
- 1-inch open-end torque wrench (set to 72 in-lb)
- ESD grounding wrist strap

### Removal Procedure

Refer to [Figure 7-22](#) for this procedure.

1. Disconnect the power cord.
2. Remove the outer cover. Refer to [“Removing the Covers” on page 7-6](#). Position the analyzer bottom side up and raise the receiver deck as shown. Refer to [“Raising and Removing the Receiver Deck” on page 7-8](#) if necessary.
3. Identify the test port coupler to be removed.
4. Remove the A43 or A44 receiver step attenuator, if present. This will allow access to the test port couplers. Refer to [“Removing and Replacing the A43 and A44 35-dB Receiver Step Attenuators \(Option 016\)” on page 7-70](#).
5. With a 5/16-inch torque wrench, disconnect the two semirigid cables (item ①) from the test port coupler.
6. With a 1-inch torque wrench, remove the test port coupler nut (item ②) from the front panel.

---

**CAUTION** Be careful not to damage the center pins of the semirigid cables. Some flexing of the cables is necessary to remove the assembly. Do not over-bend the semirigid cables.

---

7. Remove the test port coupler from the analyzer. Observe the **CAUTION** above.

### Replacement Procedure

1. Reverse the order of the removal procedure.
2. Perform the post-repair adjustments, verifications, and performance tests that pertain to this removal procedure. Refer to [Table 7-2 on page 7-82](#).

Figure 7-22 A25 and A26 Test Port Couplers Removal

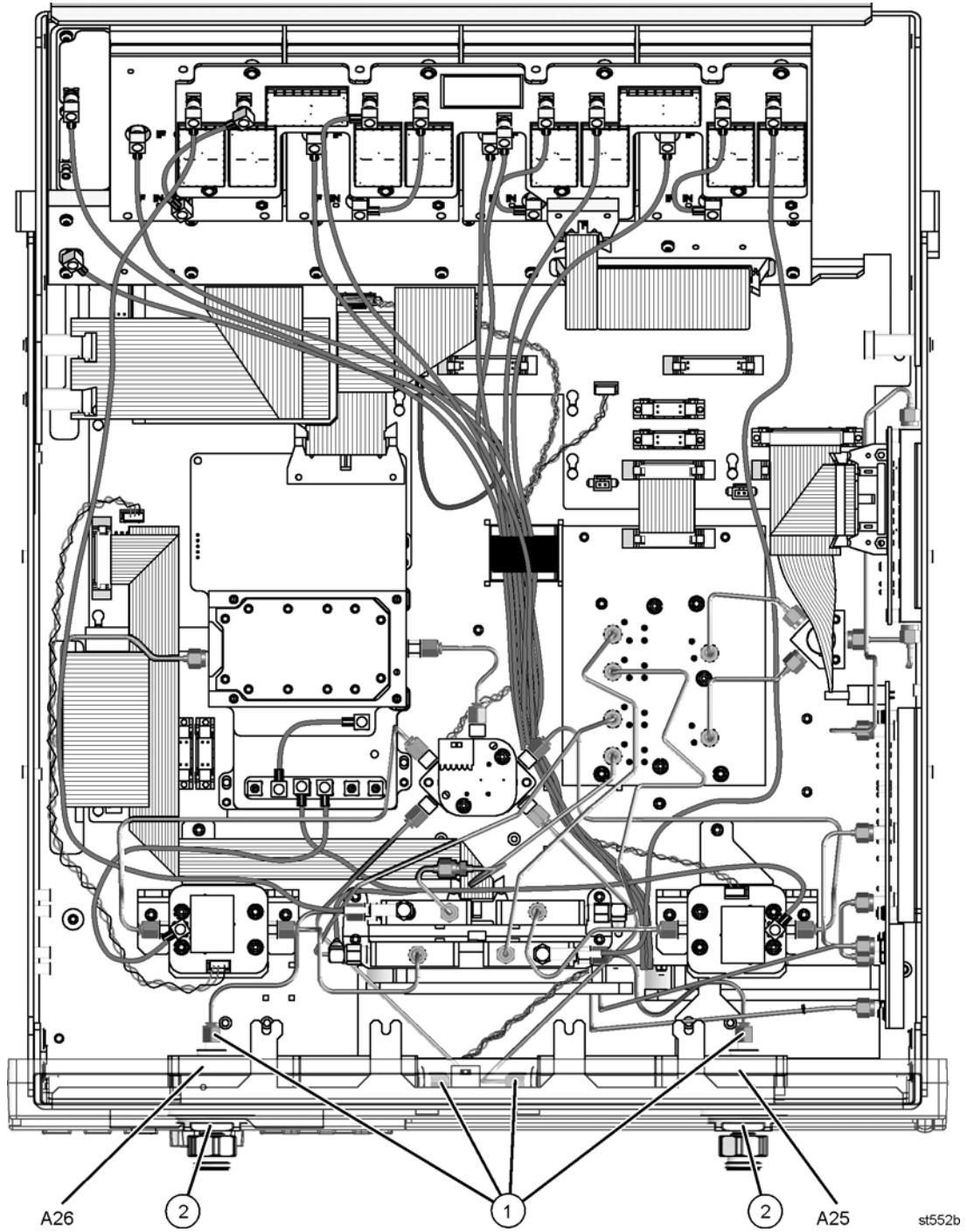

---

## Removing and Replacing the A27, A28, A29, and A30 First Converters (Mixers) and Mixer Bias Board

### Tools Required

- T-10 TORX driver (set to 9 in-lb)
- T-20 TORX driver (set to 21 in-lb)
- 5/16-inch open-end torque wrench (set to 10 in-lb)
- ESD grounding wrist strap

### Removal Procedure

Refer to [Figure 7-22](#) for this procedure.

1. Disconnect the power cord.
2. Remove the outer cover. Refer to [“Removing the Covers” on page 7-6](#). Position the analyzer bottom side up and raise the receiver deck as shown. Refer to [“Raising and Removing the Receiver Deck” on page 7-8](#) if necessary.
3. With a 5/16-inch torque wrench, disconnect the eight semirigid cables (item ①) and the four flexible cables (item ②).

---

**CAUTION** Be careful not to damage the center pins of the semirigid cables. Some flexing of the cables is necessary to remove the assembly. Do not over-bend them.

---

4. With a T-10 TORX driver, remove the four mounting screws (item ③).
5. Remove the mixer bracket and disconnect the ribbon cable (item ④). Observe the **CAUTION** above.
6. *If replacing a first converter (mixer):*
  - a. Remove the defective mixer from the bracket by removing the attachment screws.
  - b. Install the new mixer onto the bracket using the attachment screws from the mixer that was removed. Be careful to properly align the DC feed-through pins.

*If replacing the mixer bias board:*

- a. Remove all four mixers from the bracket by removing the attachment screws.
- b. Remove the mixer bias board by removing the attachment screws.
- c. Install the new mixer bias board onto the bracket by *loosely* installing the attachment screws from old the mixer bias board. Do not tighten them at this time.
- d. Reinstall the four mixers using their original attachment screws. Be careful to properly align the DC feed-through pins.
- e. Using a T-10 TORX driver, tighten the mixer bias board attachment screws.

### Replacement Procedure

1. Reverse the order of the removal procedure.
2. Perform the post-repair adjustments, verifications, and performance tests that pertain to this removal procedure. Refer to [Table 7-2 on page 7-82](#).

Figure 7-23 A27, A28, A29, and A30 First Converters (Mixers) Removal

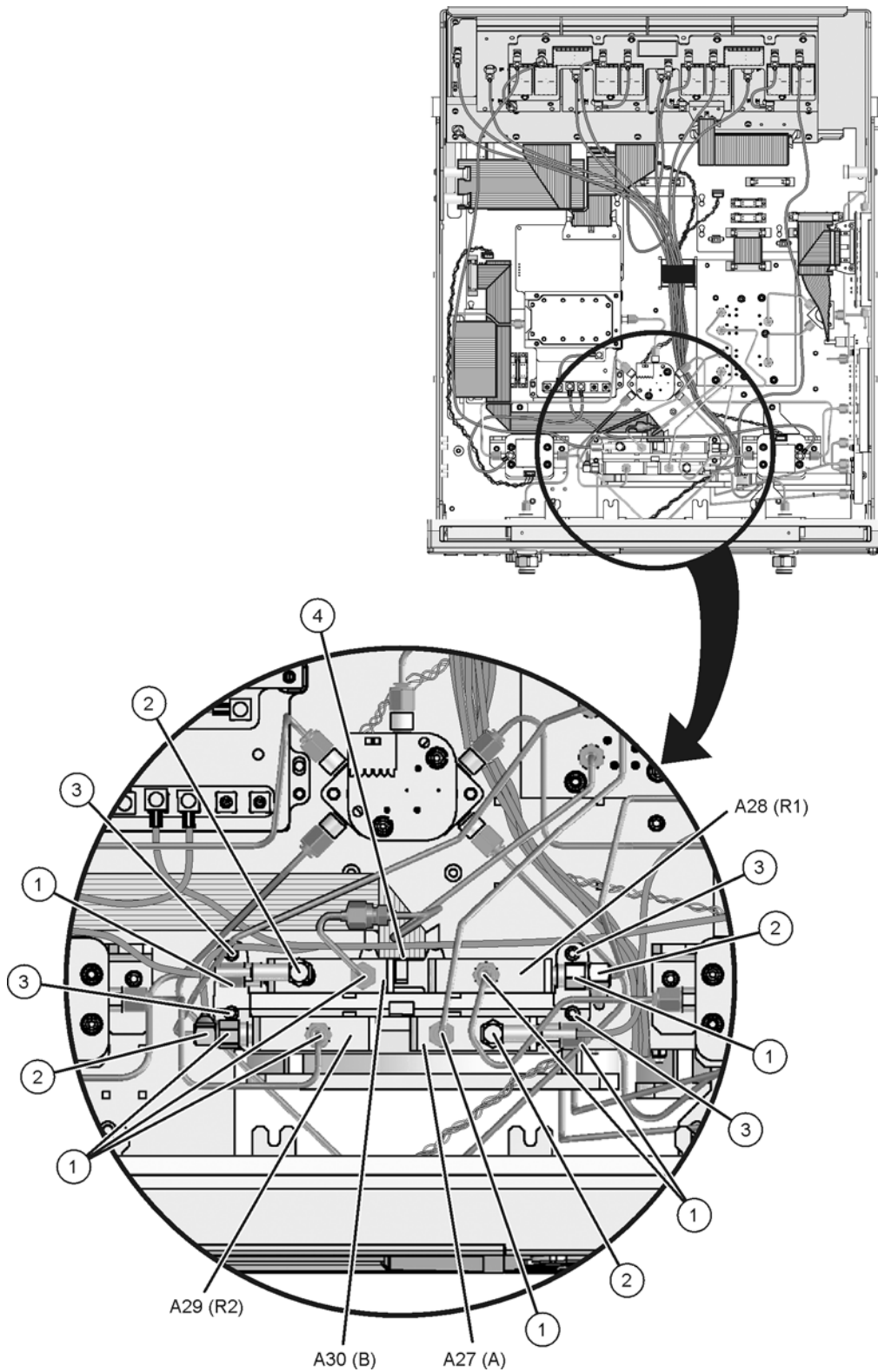

st553b

---

## Removing and Replacing the A31, A32, A33, and A34 Receiver Modules and A49 IF Multiplexer Board

### Tools Required

- T-10 TORX driver (set to 9 in-lb)
- T-20 TORX driver (set to 21 in-lb)
- 5/16-inch open-end torque wrench (set to 10 in-lb)
- ESD grounding wrist strap

### Removal Procedure

Refer to [Figure 7-24](#) for this procedure.

1. Disconnect the power cord.
2. Remove the outer cover. Refer to [“Removing the Covers” on page 7-6](#). Position the analyzer bottom side up and raise the receiver deck as shown. Refer to [“Raising the Receiver Deck” on page 7-8](#) if necessary.
3. Identify the receiver module to be removed. To replace one of the receiver modules, the A49 IF multiplexer board must be removed from the receiver motherboard.
4. Disconnect the flexible cables from the A49 IF multiplexer board and the receiver modules.
5. Disconnect the ribbon cable from the A49 IF multiplexer board.
6. With a T-10 TORX driver, remove the eight mounting screws (item ①) from the A49 IF multiplexer board. Remove the board from the receiver motherboard.
7. With a T-10 TORX driver, remove the three mounting screws (item ②) from the appropriate receiver module.
8. Remove the receiver module from the analyzer.

### Replacement Procedure

1. Reverse the order of the removal procedure.
2. Perform the post-repair adjustments, verifications, and performance tests that pertain to this removal procedure. Refer to [Table 7-2 on page 7-82](#).

**Figure 7-24 A31, A32, A33, and A34 Modules and A49 IF Multiplexer Board Removal**

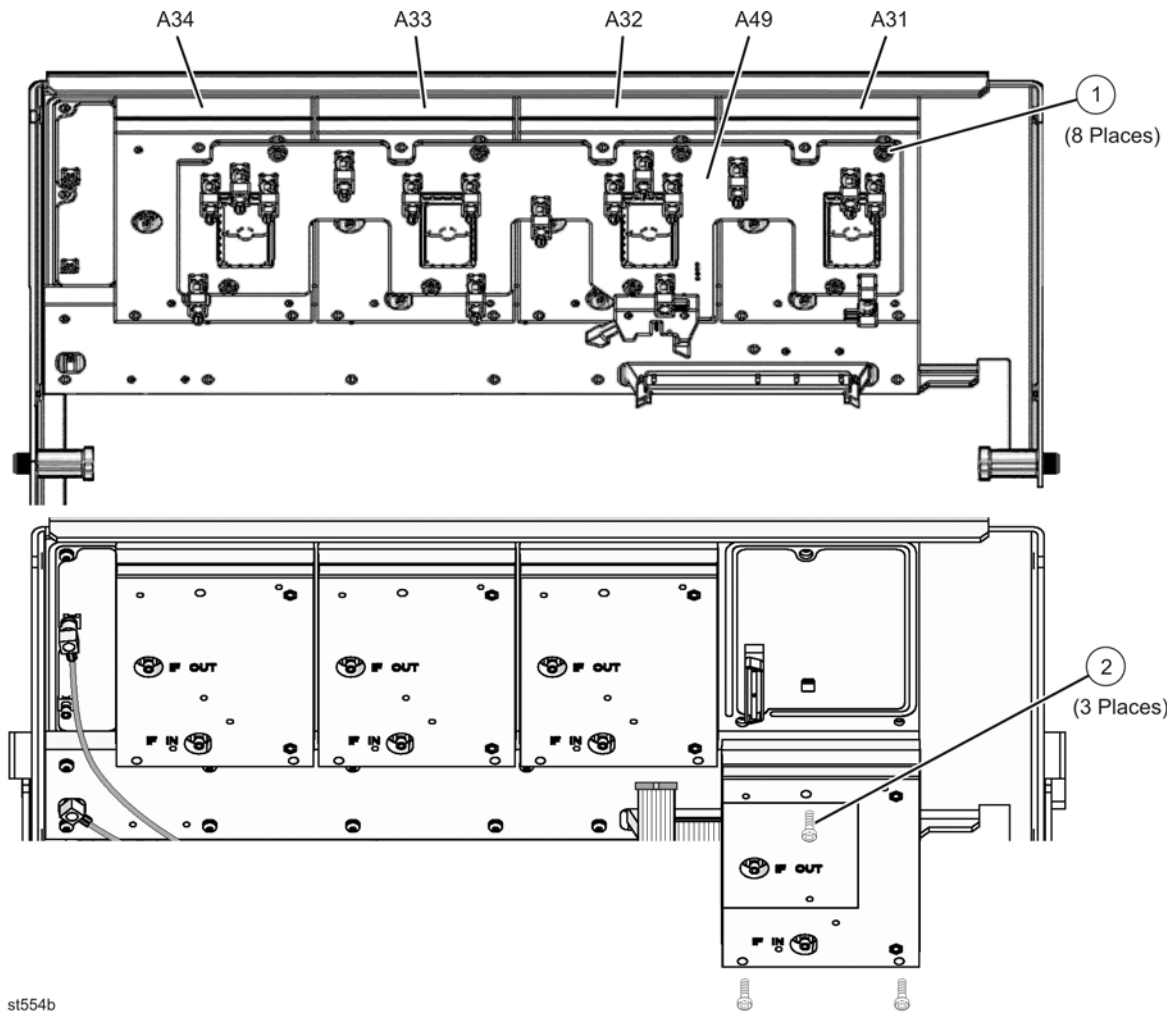

---

## Removing and Replacing the A35 Receiver Motherboard

### Tools Required

- T-10 TORX driver (set to 9 in-lb)
- T-20 TORX driver (set to 21 in-lb)
- 5/16-inch open-end torque wrench (set to 10 in-lb)
- ESD grounding wrist strap

### Removal Procedure

Refer to [Figure 7-13](#) for this procedure.

1. Disconnect the power cord.
2. Remove the outer covers. Refer to [“Removing the Covers” on page 7-6](#). Position the analyzer bottom side up and raise the receiver deck as shown. Refer to [“Raising the Receiver Deck” on page 7-8](#) if necessary.
3. Remove the A49 IF multiplexer board and all four receiver modules. Refer to [“Removing and Replacing the A31, A32, A33, and A34 Receiver Modules and A49 IF Multiplexer Board” on page 7-54](#).
4. Disconnect the flexible cables (item ①) from the receiver motherboard.
5. Disconnect the flexible cable (item ②) from the receiver motherboard if present (Option 080 only).
6. Disconnect the ribbon cable (item ③) from the receiver motherboard.
7. Remove the receiver deck from the analyzer with the receiver motherboard attached. Refer to [“Removing the Receiver Deck” on page 7-8](#), if necessary. The receiver motherboard and receiver deck are replaced as one unit.

### Replacement Procedure

1. Reverse the order of the removal procedure.
2. Perform the post-repair adjustments, verifications, and performance tests that pertain to this removal procedure. Refer to [Table 7-2 on page 7-82](#).



Figure 7-25 A35 Receiver Motherboard Removal

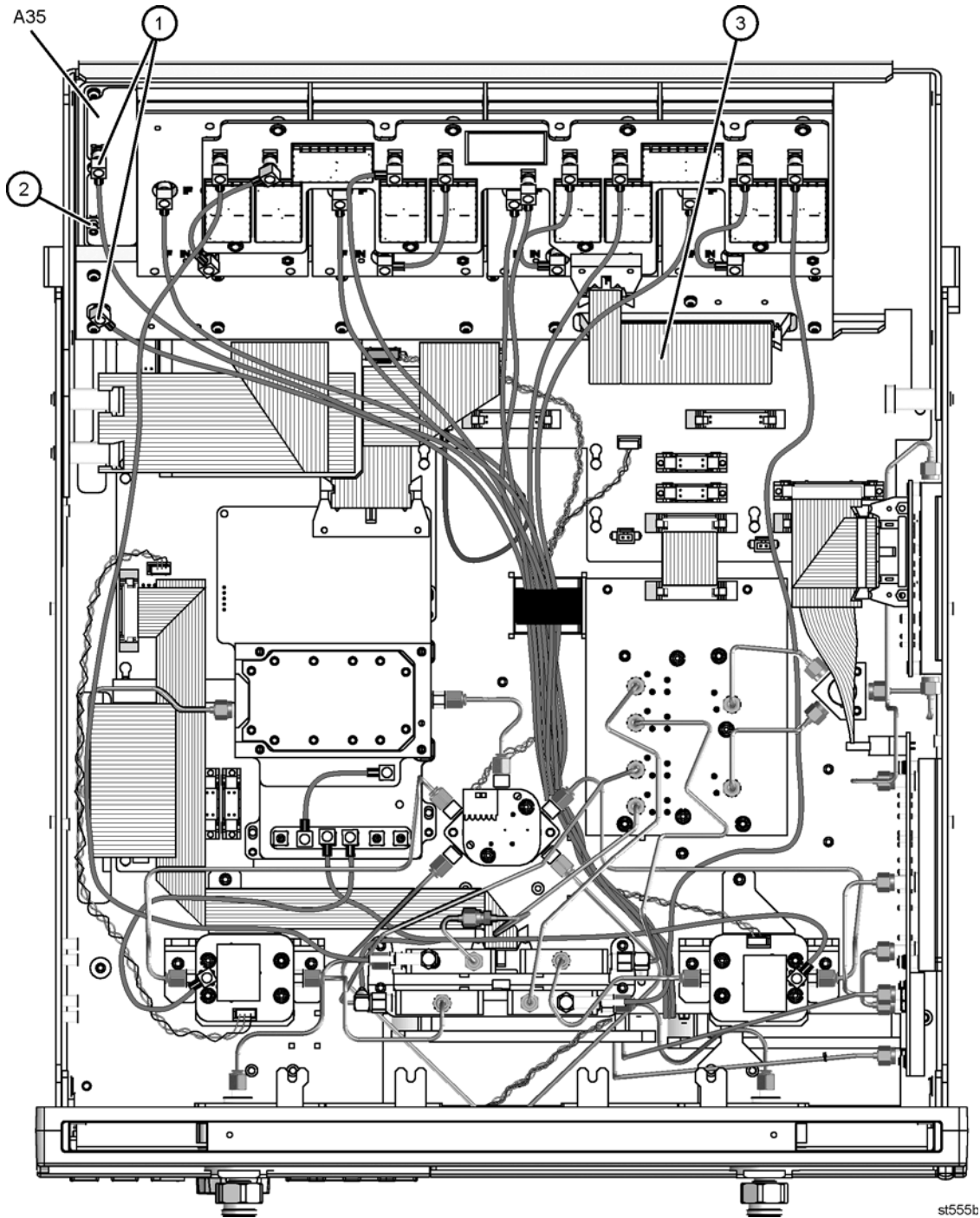

---

## Removing and Replacing the A36 and A37 60-dB Source Step Attenuators (Option UNL)

### Tools Required

- T-10 TORX driver (set to 9 in-lb)
- T-20 TORX driver (set to 21 in-lb)
- 5/16-inch open-end torque wrench (set to 10 in-lb)
- ESD grounding wrist strap

### Removal Procedure

Refer to [Figure 7-26](#) for this procedure.

1. Disconnect the power cord.
2. Remove the outer cover. Refer to [“Removing the Covers” on page 7-6](#). Position the analyzer bottom side up and raise the receiver deck as shown. Refer to [“Raising the Receiver Deck” on page 7-8](#) if necessary.
3. Identify the step attenuator to be removed. To replace the attenuator, the bracket holding the attenuator, detector (E8363C/E8364C) or fixed pad (E8362C), and bias tee must be removed.
4. Disconnect the ribbon cable (item ①) from the appropriate attenuator.
5. With a 5/16-inch torque wrench, disconnect the two semirigid cables (item ②) from the appropriate step attenuator, two semirigid cables (item ③) from the detector (or fixed pad), and two semirigid cables (item ④) from the bias tee.
6. Disconnect the stranded control cable (item ⑤) and the flexible cable (item ⑥) from the appropriate detector (E8363C/E8364C only) and the stranded bias tee cable (item ⑦) from A16 test set motherboard. (Release the bias tee cable such that it can be removed with the bias tee.)
7. With a T-10 TORX driver, remove the three mounting screws (item ⑧) from the bracket holding the attenuator, detector (or fixed pad), and bias tee.

---

**CAUTION** Be careful not to damage the center pins of the semirigid cables. Some flexing of the cables is necessary to remove the assembly. Do not over-bend the semirigid cables.

---

8. Remove the bracket from the analyzer with the attenuator, detector (or fixed pad), and bias tee attached. Observe the **CAUTION** above.
9. With a T-10 TORX driver, remove the two mounting screws holding the attenuator.

### Replacement Procedure

1. Reverse the order of the removal procedure using the existing attenuator ribbon cable.
2. Perform the post-repair adjustments, verifications, and performance tests that pertain to this removal procedure. Refer to [Table 7-2 on page 7-82](#).

Figure 7-26 A36 and A37 60-dB Source Step Attenuators Removal (Option UNL)

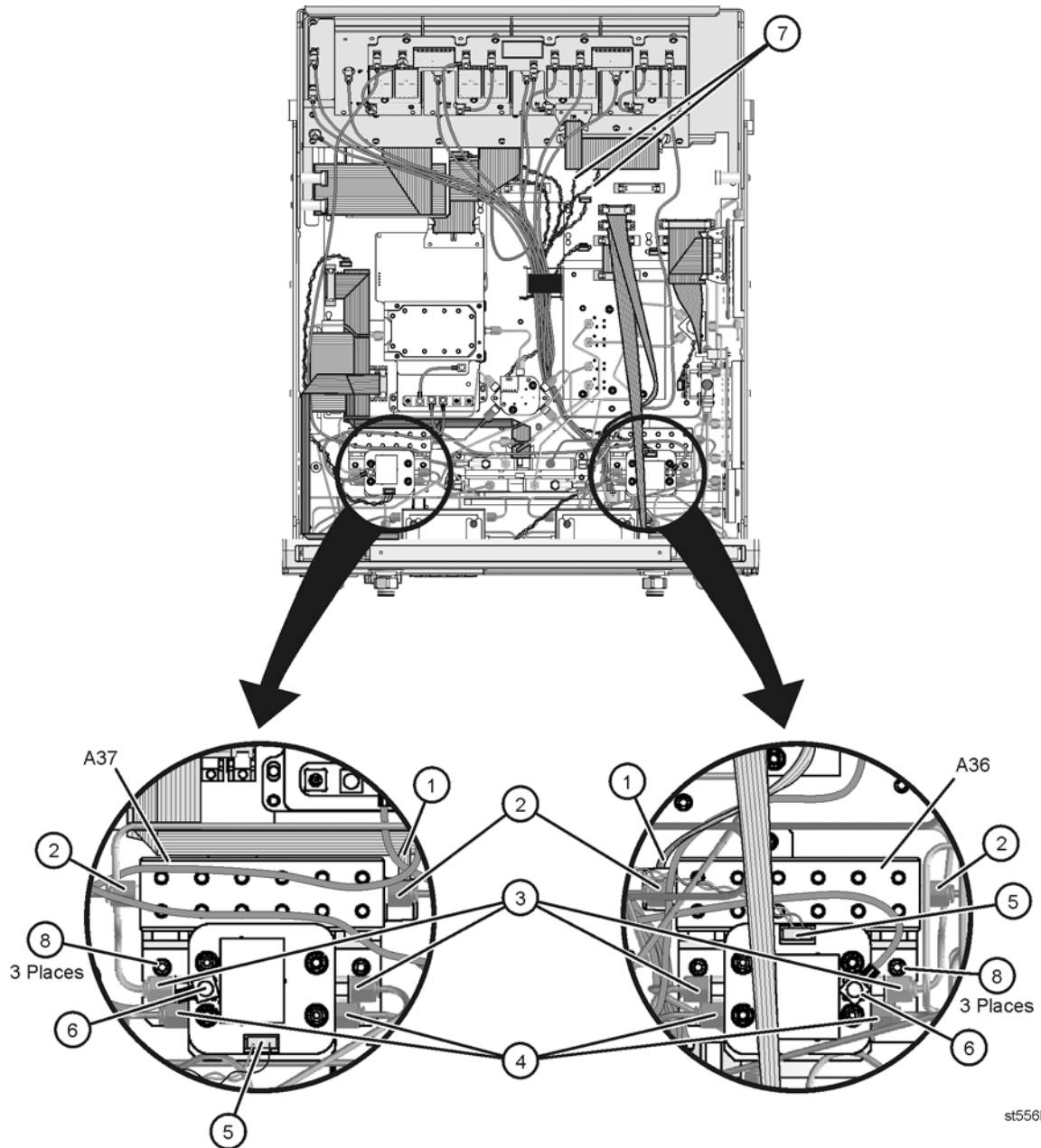

---

## Removing and Replacing the A38 and A39 Bias Tees (Option UNL)

### Tools Required

- T-8 TORX driver (set to 5 in-lb)
- T-10 TORX driver (set to 9 in-lb)
- T-20 TORX driver (set to 21 in-lb)
- 5/16-inch open-end torque wrench (set to 10 in-lb)
- ESD grounding wrist strap

### Removal Procedure

Refer to [Figure 7-26](#) for this procedure.

1. Disconnect the power cord.
2. Remove the outer cover. Refer to “[Removing the Covers](#)” on page 7-6. Position the analyzer bottom side up and raise the receiver deck as shown. Refer to “[Raising the Receiver Deck](#)” on page 7-8 if necessary.
3. Identify the bias tee to be removed. To replace the bias tee, the bracket holding the attenuator, detector (E8363C/E8364C) or fixed pad (E8362C), and bias tee must be removed.
4. Disconnect the ribbon cable (item ①) from the appropriate attenuator.
5. With a 5/16-inch torque wrench, disconnect the two semirigid cables (item ②) from the appropriate step attenuator, two semirigid cables (item ③) from the detector (or fixed pad), and two semirigid cables (item ④) from the bias tee.
6. Disconnect the stranded control cable (item ⑤) and the flexible cable (item ⑥) from the appropriate detector (E8363C/E8364C only) and the stranded bias tee cable (item ⑦) from A16 test set motherboard. (Release the bias tee cable such that it can be removed with the bias tee.)
7. With a T-10 TORX driver, remove the three mounting screws (item ⑧) from the bracket holding the attenuator, detector (or fixed pad), and bias tee.

---

**CAUTION** Be careful not to damage the center pins of the semirigid cables. Some flexing of the cables is necessary to remove the assembly. Do not over-bend the semirigid cables.

---

8. Remove the bracket from the analyzer with the attenuator, detector (or fixed pad), and bias tee attached. Observe the **CAUTION** above.
9. With a T-8 TORX driver, remove the mounting screws holding the bias tee and install the new bias tee with cable.

### Replacement Procedure

1. Reverse the order of the removal procedure.
2. Perform the post-repair adjustments, verifications, and performance tests that pertain to this removal procedure. Refer to [Table 7-2 on page 7-82](#).

Figure 7-27 A38 and A39 Bias Tees Removal (Option UNL)

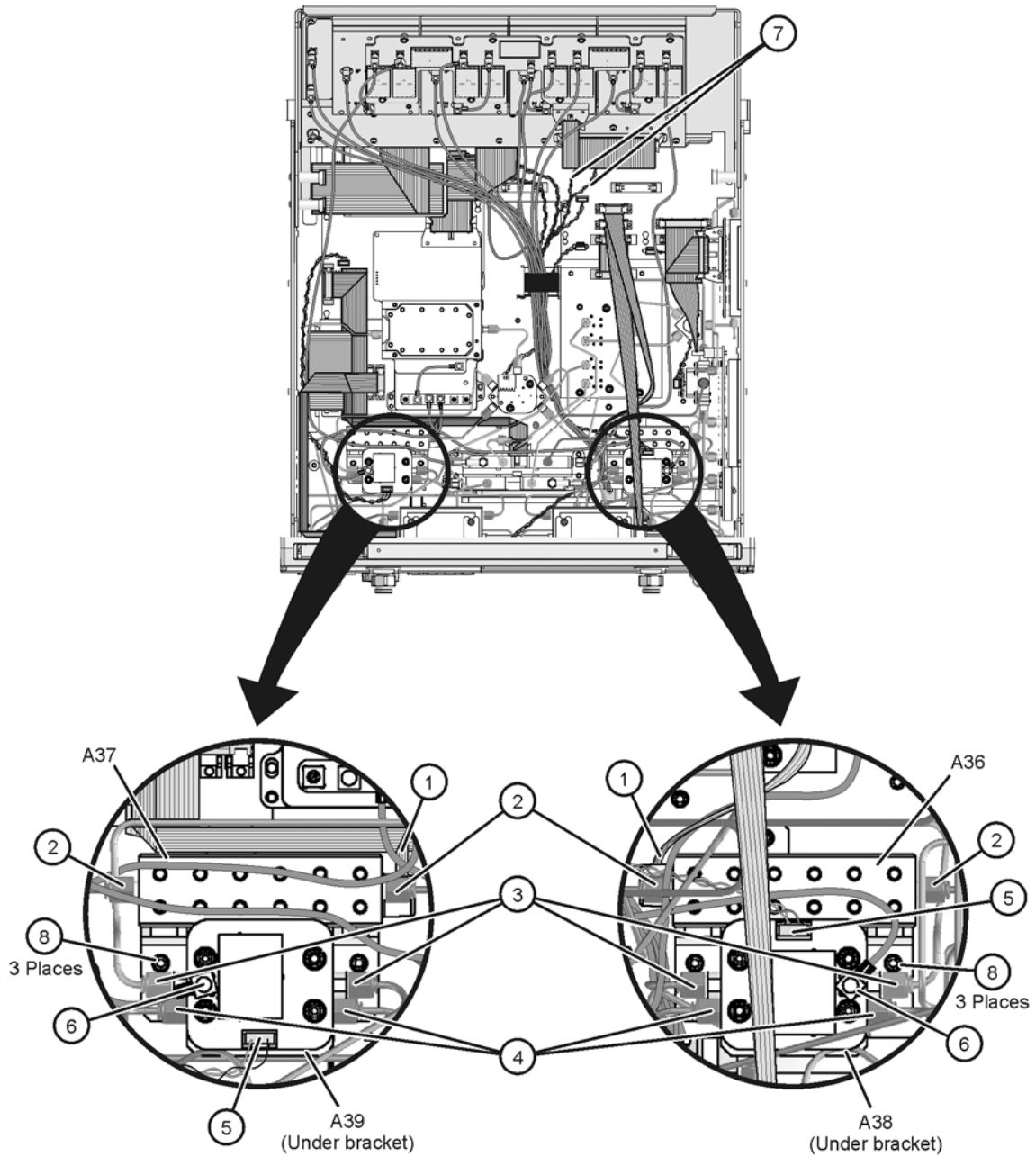

st557b

---

## Removing and Replacing the A41 Hard Disk Drive (HDD)

Certain unique files exist on the hard disk drive that are necessary for proper operation of your analyzer. These files must be copied to another location to allow them to be installed onto the new HDD after it has been installed.

If you are replacing the HDD, not just removing the hard disk drive assembly (HDDA) to allow access to other assemblies, the following procedure must be performed first.

If you are not replacing the actual HDD, proceed to [“Tools Required,”](#) on this page.

### Copy Unique Files from the Hard Disk

1. Insert a USB flash memory drive into a USB port.
2. Open *Windows Explorer*.
3. Navigate to C:\Program Files\Agilent\Network Analyzer.
4. Copy each of the following files from the hard disk drive to the USB drive:
  - gen.lic
  - user\_calokitfile
  - All files prefixed with mxcalfile\_.
  - Any personal user files that you wish to preserve.
5. Remove the USB drive from the USB port.
6. Exit *Windows Explorer*.

### Tools Required

- T-10 TORX driver (set to 7 in-lb; for hard disk drive replacement)
- T-10 TORX driver (set to 9 in-lb; for all other T-10 applications)
- ESD grounding wrist strap

### Removal Procedure

1. Disconnect the analyzer power cord.  
Refer to [Figure 7-28](#) for the remainder of this procedure.
2. With a T-10 TORX driver, loosen the four HDDA mounting screws (item ①) on the rear panel.
3. Remove the HDDA from the analyzer by pulling on the finger grip (item ②). The HDDA interconnects with a connector inside the analyzer rear panel so moderate force may be necessary to disengage this connector.

**Figure 7-28** Hard Disk Drive Assembly Removal

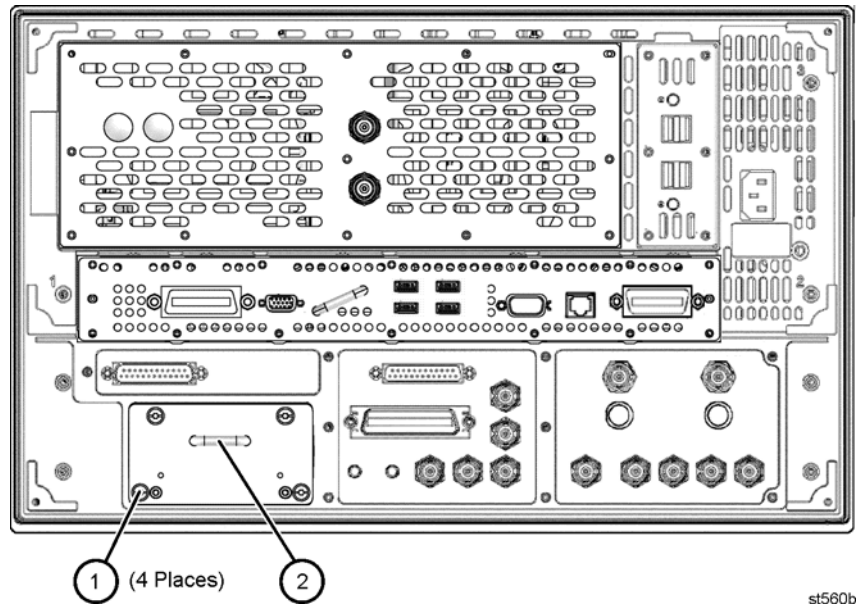

st560b

### Disassembling the HDDA

---

**NOTE** If the HDD is being replaced by the HDDA (N8980A or N8981A), it is not necessary to perform these steps.

---

Refer to [Figure 7-29](#) and [Figure 7-30](#).

1. Remove the HDDA from the analyzer. Refer to “Removal Procedure” on page 7-62.
2. With a T-10 TORX driver, remove the following items that mount the HDD (item ④), to the bracket:
  - a. The four screws (item ①).
  - b. If the HDD is equipped with the serial ATA interface:
    - the six bushings (item ②)
    - the nylon spacer (item ⑤)
  - c. If the HDD is equipped with the parallel ATA interface:
    - the eight bushings (item ②)
3. Disconnect the HDD (item ④) from the interface board (item ③).

Figure 7-29 Hard Disk Drive Assembly with Parallel ATA Interface (Exploded View)

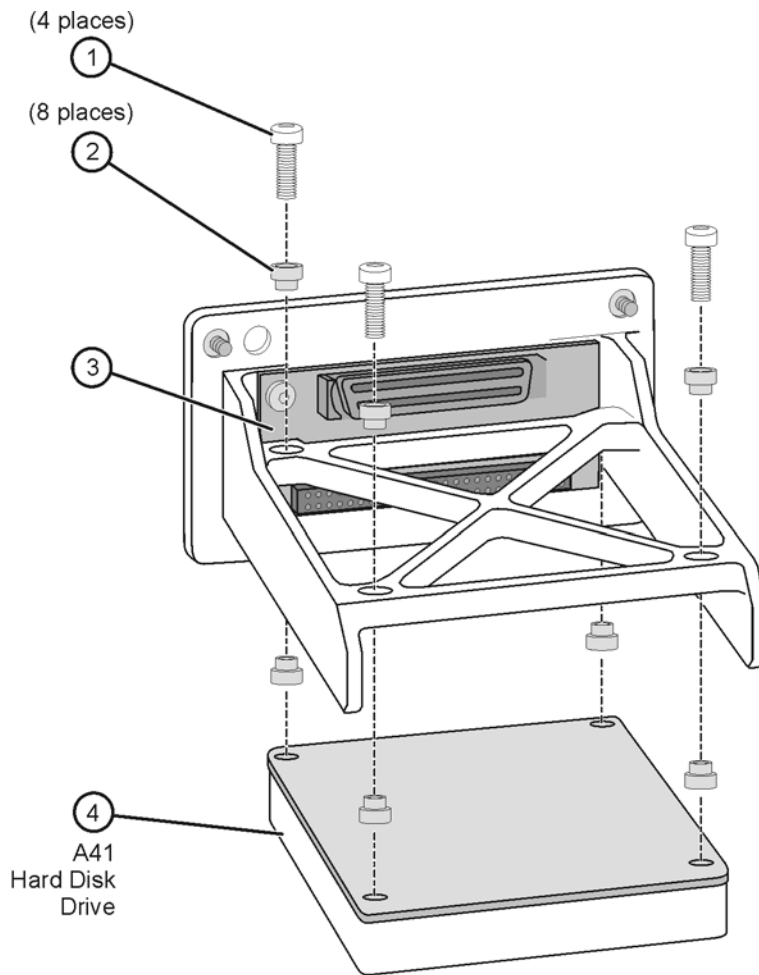

st561a



**Figure 7-30** Hard Disk Drive Assembly with Serial ATA Interface (Exploded View)

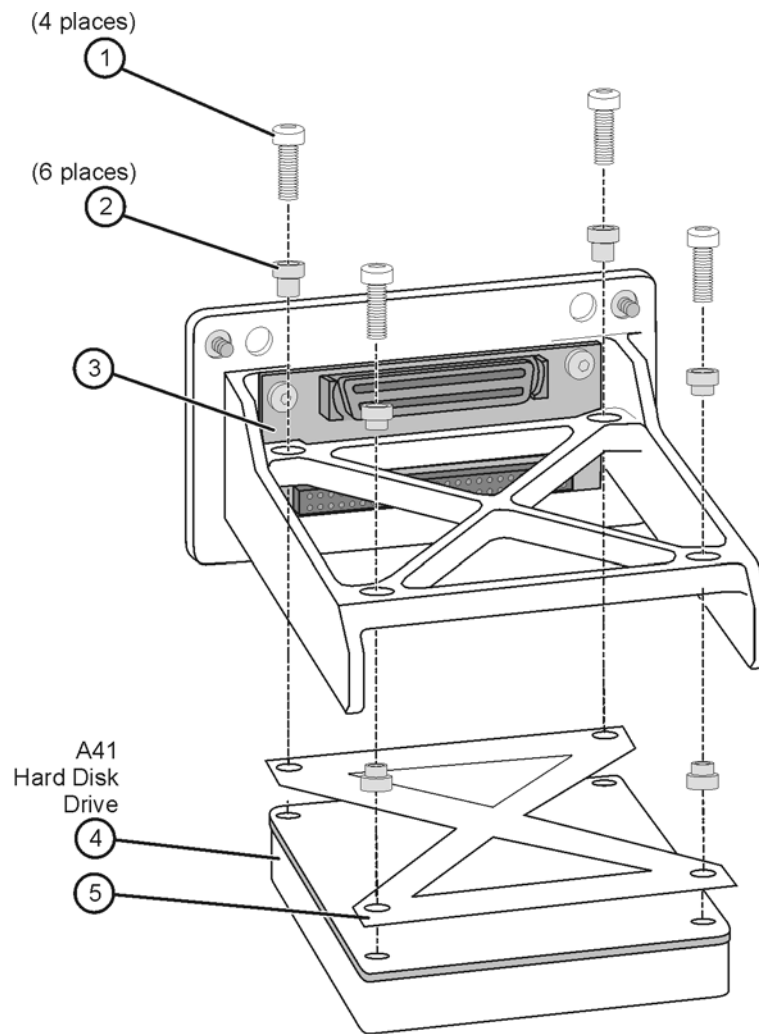

S561a1

## Reassembly Procedure

---

**NOTE** If the HDD is being replaced by the HDDA (N8980A or N8981A), it is not necessary to perform these steps.

---

If the HDD is equipped with a parallel ATA interface, follow the step below.

- With the disk drive bracket right-side up (it is shown upside down in [Figure 7-29 on page 7-64](#)), insert four bushings (item ②) into the four holes in the bracket.

If the HDD is equipped with a serial ATA interface, follow the step below.

- With the disk drive bracket right-side up (it is shown upside down in [Figure 7-30 on page 7-65](#)), insert two bushings (item ②) with *short* collars in the two holes on the bracket that are furthest from the interface board.
- Place the nylon spacer (item ⑤) on the bracket.

Regardless of which ATA interface the HDD is equipped with, follow the steps below.

1. Connect the new HDD (item ④) to the interface board (item ③) by pushing it firmly into the connector on the interface board. **Take special care to align the connector pins. Applying power to a misaligned connection can permanently damage the HDD.**
2. While holding the HDD in place, turn the bracket over and insert the other four bushings (item ②), into the other side of the holes. As per [Figure 7-30 on page 7-65](#), the Serial ATA Interface uses bushings with *long* collars in the two holes on the bracket that are closest to the interface board.
3. Install the four screws (item ①), finger tight, through the four bushings (item ②), to attach the HDD to the bracket.

**With a T-10 TORX driver, snug-tighten the four screws in a Z-pattern, and then torque them, in the same pattern, to 7 in-lb.**

## Reinstalling the HDDA

1. Reinstall the HDDA into the analyzer:
  - a. Slide the HDDA into the slot in the rear panel and push it firmly into place to engage the connector. Refer to [Figure 7-28 on page 7-63](#).
  - b. With a T-10 TORX driver, tighten the four HDDA mounting screws (item ①).

## Initialize the Windows Operating System

1. Connect a mouse and keyboard to the analyzer.
2. Turn on power to the analyzer.
3. The operating system initialization process will run automatically. Part way through the process, you will be prompted to accept the Windows licensing agreement. The entire process takes approximately six minutes, during which the analyzer will reboot up to three times.
4. After the PNA application screen is displayed, there may be a display to remind you to upgrade the firmware. If so, click **OK** to continue.

## Set Up the Agilent Administrator Password

After an HDD replacement, it is necessary to set up the Agilent administrator password for the analyzer. Go to the following Internet site, enter your PNA serial number, and get a six-digit numerical password:

<http://na.tm.agilent.com/pna/hdd/index.html#agpswd>.

The network analyzer must be powered up and operating for this procedure.

1. On the **Windows Desktop**, right-click on **My Computer**, and then click **Manage**.
2. In the **Computer Management** window, navigate to **System Tools, Local Users and Groups, Users**.
3. Right-click on **Agilent**, click on **Set Password**, and complete these steps in the window:
  - a. Type the password obtained from Agilent as the **Password**. Refer to “[Set Up the Agilent Administrator Password](#)” on page 7-67 for information if you have not yet obtained this password.
  - b. Type the password again in the **Confirm password** block.
  - c. Click **OK**.
4. Right-click on **Agilent**, click on **Properties**, and complete these steps in the window:
  - a. Unselect **User must change password at next logon** (if not already unselected).
  - b. Unselect **User cannot change password** (if not already unselected).
  - c. Select **Password never expires** (if not already selected).
  - d. Click **OK**.
5. Close the **Computer Management** window.

## Install Backup Files onto the New Hard Disk Drive

The files that were previously saved onto a USB memory drive must now be installed onto the new HDD. The network analyzer must be powered up and operating.

1. Insert the USB memory drive containing the backup files into a USB port.
2. Click on **START**. (It may be necessary to exit the **Network Analyzer** application.)
3. Point to **Programs, Accessories**, and then open **Windows Explorer**.
4. Navigate to C:\Program Files\Agilent\Network Analyzer.
5. Copy each of the backup files from the USB memory drive to the HDD.

6. Navigate to D:\CalFiles\.
7. Copy the backup files prefixed with mxcalfile\_ from the USB memory drive to the HDD.
8. After all files have been copied, remove the USB memory drive from the USB port.
9. Exit *Windows Explorer*.

### **Post-Repair Procedures**

1. Adhere the new Certificate of Authenticity (license) label to the outer cover in the location specified in [Figure 7-1 on page 7-7](#).
2. Perform the post-repair adjustments, verifications, and performance tests that pertain to this removal procedure. Refer to [Table 7-2 on page 7-82](#).



---

## Removing and Replacing the A43 and A44 35-dB Receiver Step Attenuators (Option 016)

### Tools Required

- T-10 TORX driver (set to 9 in-lb)
- T-20 TORX driver (set to 21 in-lb)
- 5/16-inch open-end torque wrench (set to 10 in-lb)
- ESD grounding wrist strap

### Removal Procedure

Refer to [Figure 7-26](#) for this procedure.

1. Disconnect the power cord.
2. Remove the outer cover. Refer to [“Removing the Covers” on page 7-6](#). Position the analyzer bottom side up and raise the receiver deck as shown. Refer to [“Raising the Receiver Deck” on page 7-8](#) if necessary.
3. Identify the step attenuator to be removed.
4. Disconnect the ribbon cable (item ①) from the appropriate attenuator.
5. With a 5/16-inch torque wrench, disconnect the two semirigid cables (item ②) from the attenuator.
6. With a T-10 TORX driver, remove the two mounting screws (item ③). Support the attenuator while removing the mounting hardware.

---

**CAUTION** Be careful not to damage the center pins of the semirigid cables. Some flexing of the cables is necessary to remove the assembly. Do not over-bend the semirigid cables.

---

7. Remove the attenuator from the analyzer. Observe the **CAUTION** above.

### Replacement Procedure

1. Reverse the order of the removal procedure using the existing attenuator ribbon cable.
2. Perform the post-repair adjustments, verifications, and performance tests that pertain to this removal procedure. Refer to [Table 7-2 on page 7-82](#).

Figure 7-31 A43 and A44 35-dB Receiver Step Attenuators Removal (Option 016)

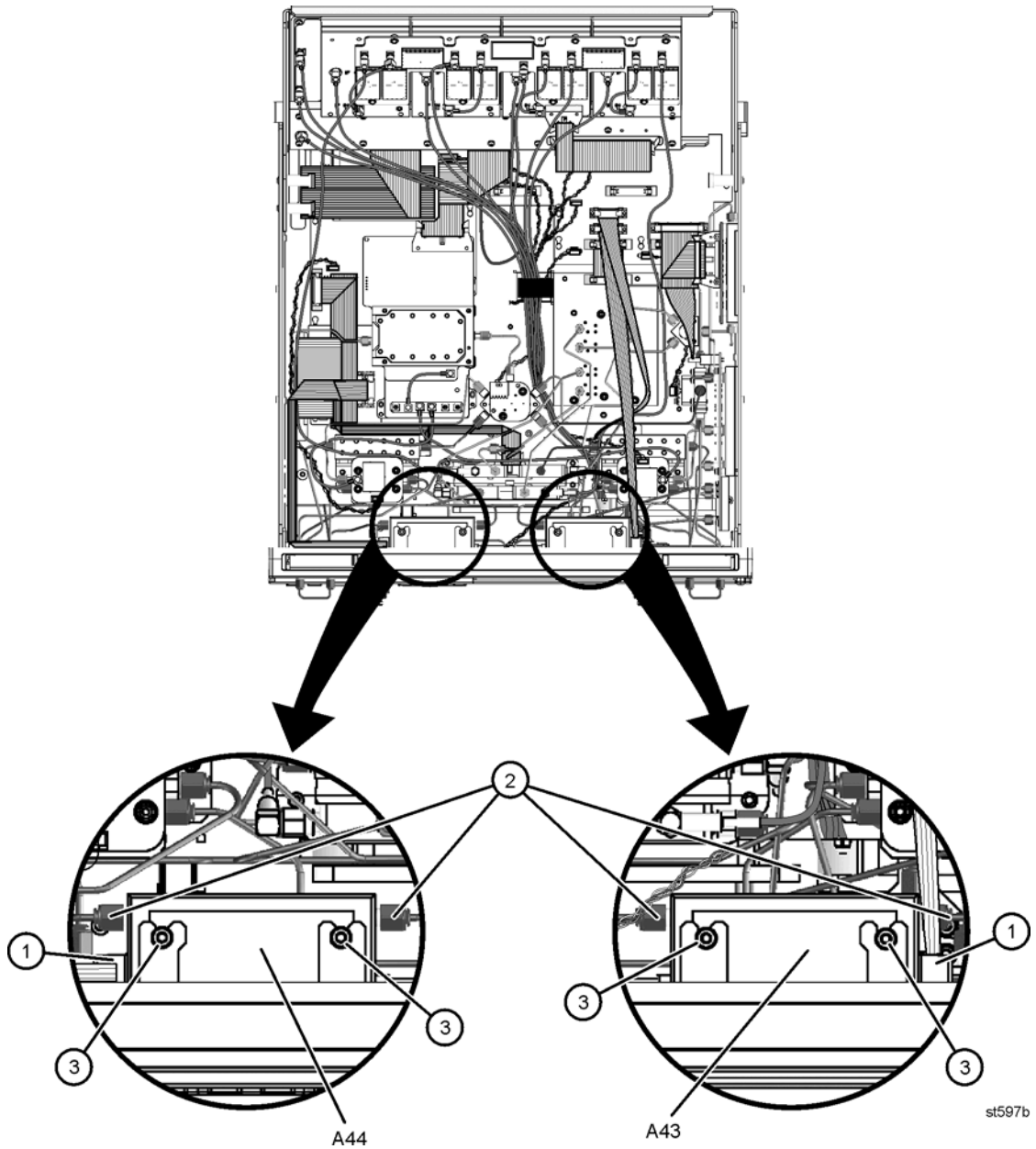

---

## Removing and Replacing the A45 and A46 Reference Channel Transfer Switches (Option 081)

### Tools Required

- T-10 TORX driver (set to 9 in-lb)
- T-20 TORX driver (set to 21 in-lb)
- 5/16-inch open-end torque wrench (set to 10 in-lb)
- ESD grounding wrist strap

### Removal Procedure

Refer to [Figure 7-26](#) for this procedure.

1. Disconnect the power cord.
2. Remove the outer cover. Refer to [“Removing the Covers” on page 7-6](#). Position the analyzer bottom side up and raise the receiver deck as shown. Refer to [“Raising the Receiver Deck” on page 7-8](#) if necessary.
3. Identify the switch assembly to be removed. If removing A45, go to step 4. If removing A46, perform the following steps first.
  - a. Remove the A43 receiver step attenuator, if present. Refer to [“Removing and Replacing the A43 and A44 35-dB Receiver Step Attenuators \(Option 016\)” on page 7-70](#).
  - b. Remove the A25 test port coupler. Refer to [“Removing and Replacing the A25 and A26 Test Port Couplers” on page 7-50](#).
4. Disconnect the stranded control cable (item ①) by pressing the release button in the center of the connector.
5. With a 5/16-inch torque wrench, disconnect the three semirigid cables (item ②) from the A45 or A46 reference channel switch.
6. With a T-10 TORX driver, remove the four mounting screws (item ③) holding A46 or the two mounting screws (item ④) holding the A45 mounting bracket.

---

**CAUTION** Be careful not to damage the center pins of the semirigid cables. Some flexing of the cables is necessary to remove the assembly. Do not over-bend the semirigid cables.

---

7. Remove A45 or A46 from the analyzer. Observe the **CAUTION** above.
8. With a T-10 TORX driver, remove the four mounting screws (item ③) holding A45 to the bracket.

### Replacement Procedure

1. Reverse the order of the removal procedure.
2. Perform the post-repair adjustments, verifications, and performance tests that pertain to this removal procedure. Refer to [Table 7-2 on page 7-82](#).



Figure 7-32 A45 and A46 Reference Channel Transfer Switches Removal (Option 081)

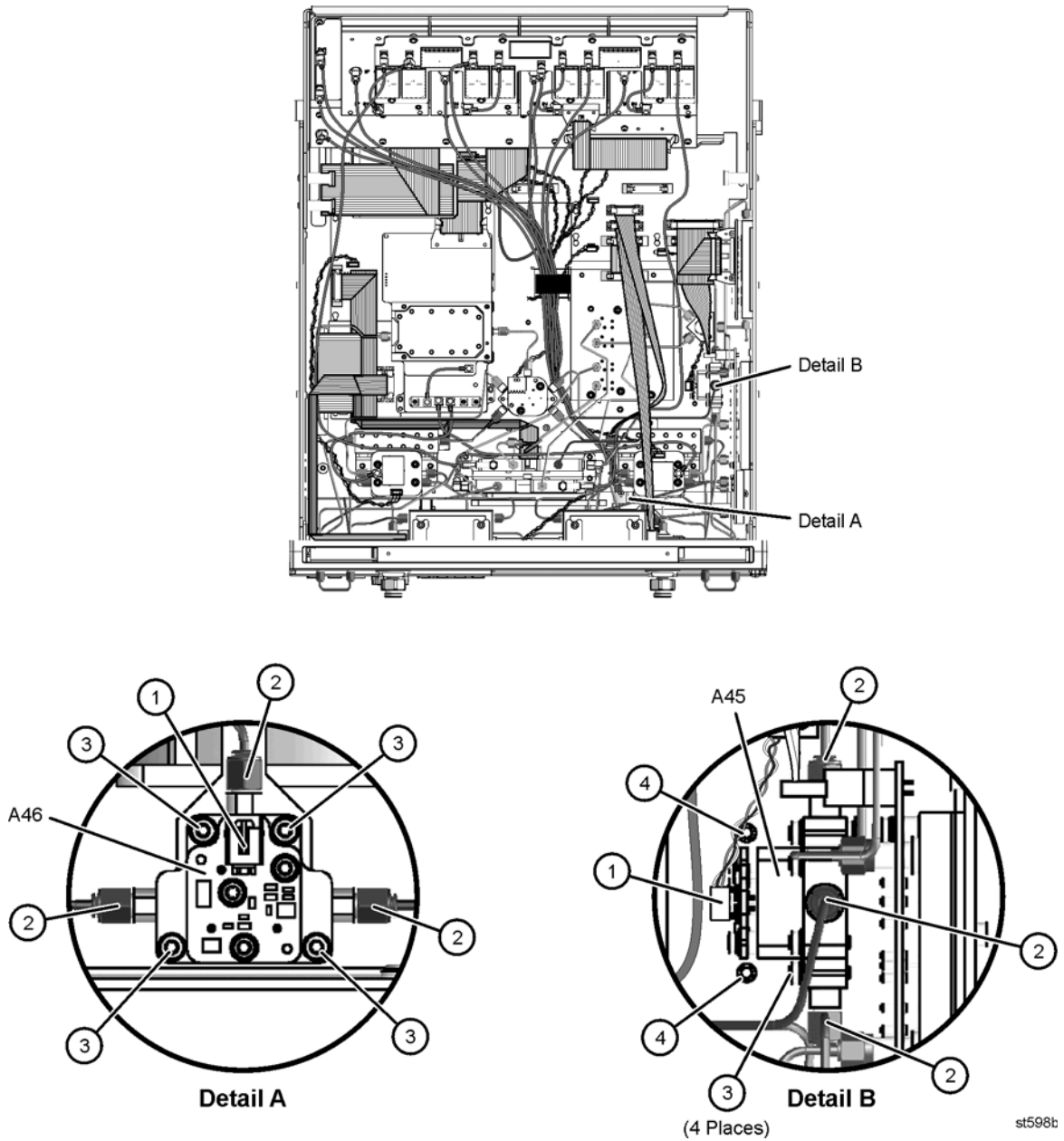

---

## Removing and Replacing the A47 and A48 Couplers (Option H11)

### Tools Required

- T-10 TORX driver (set to 9 in-lb)
- T-20 TORX driver (set to 21 in-lb)
- 5/16-inch open-end torque wrench (set to 10 in-lb)
- ESD grounding wrist strap

### Removal Procedure

Refer to [Figure 7-33](#) for this procedure.

1. Disconnect the power cord.
2. Remove the outer cover. Refer to [“Removing the Covers” on page 7-6](#). Position the analyzer bottom side up and raise the receiver deck as shown. Refer to [“Raising the Receiver Deck” on page 7-8](#) if necessary.
3. Locate the coupler to be removed; the A47 RF path coupler or the A48 LO path coupler. The A47 RF path coupler is secured to the analyzer side frame (test set deck) and the A48 LO path coupler is secured to a bracket which also holds the A19 splitter.
4. To remove the A47 RF path coupler:
  - a. With a 5/16-inch wrench, disconnect the three semirigid cables from the coupler.

---

**CAUTION** Be careful not to damage the center pins of the semirigid cables. Some flexing of the cables is necessary for removal. Do not over-bend them.

---

- b. With a T-10 TORX driver, remove the mounting screws holding the coupler.
5. To remove the A48 LO path coupler:
    - a. With a 5/16-inch wrench, disconnect the three semirigid cables from the coupler and the three semirigid cables from the A19 splitter.
    - b. With a T-10 TORX driver, remove the mounting screws from the bracket that holds the A48 LO path coupler and the A19 splitter.
  6. Remove the bracket, with the A48 LO path coupler attached, from the analyzer. Observe the **CAUTION** above.
  7. Remove the A48 LO path coupler from the bracket by removing the attachment screws.

### Replacement Procedure

1. Reverse the order of the removal procedure using the existing cables and hardware.
2. Perform the post-repair adjustments, verifications, and performance tests that pertain to this removal procedure. Refer to [Table 7-2 on page 7-82](#).

Figure 7-33 A47 and A48 Couplers Removal (Option H11)

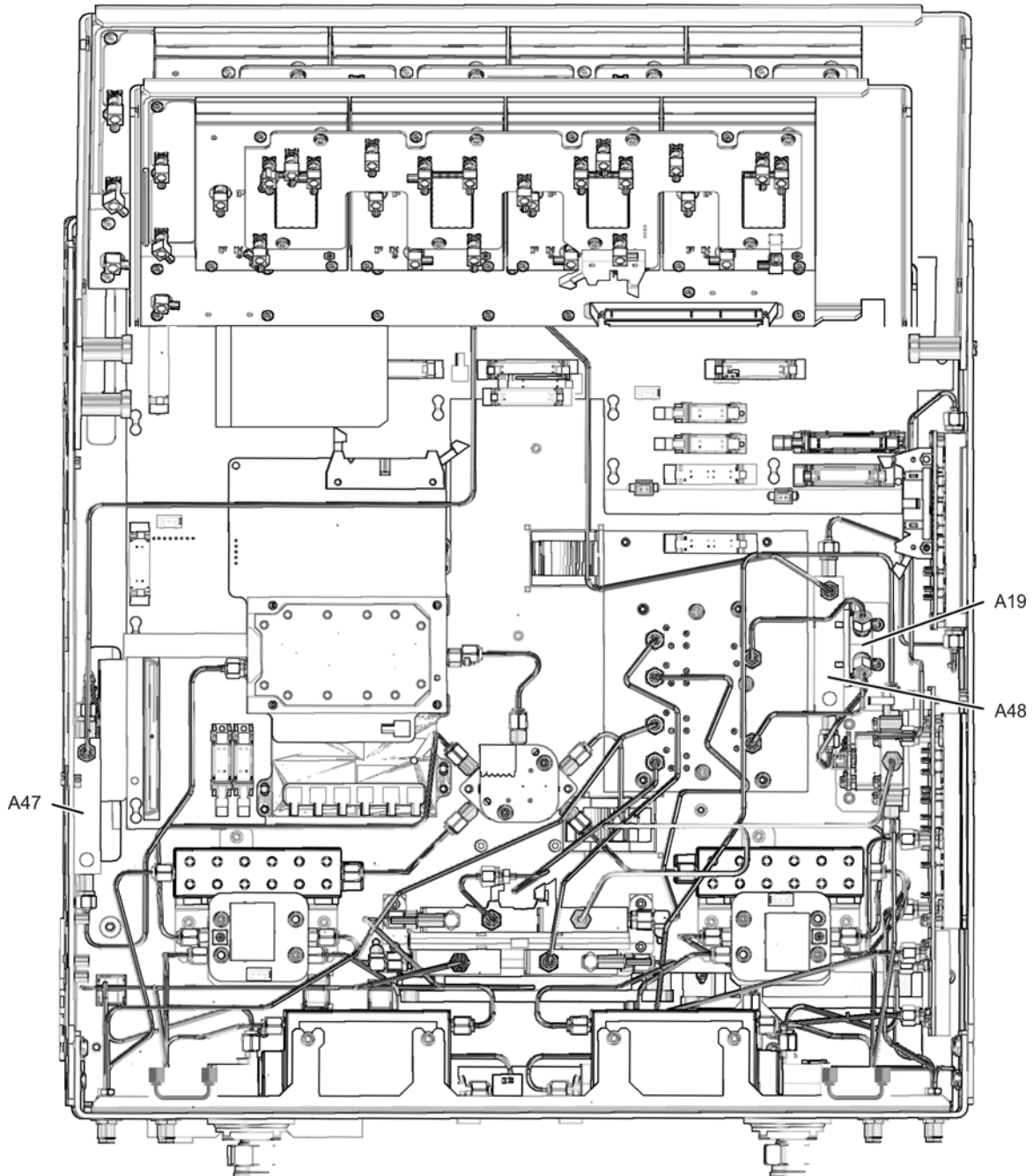

8364\_001\_701

---

## Removing and Replacing the Midweb and the B1 Fan

### Tools Required

- T-10 TORX driver (set to 9 in-lb)
- T-20 TORX driver (set to 21 in-lb)
- Pozidriv screw driver
- 5/16-inch open-end torque wrench (set to 10 in-lb)
- ESD grounding wrist strap

### Removal Procedure

1. Disconnect the power cord.
2. Remove the front panel assembly. Refer to [“Removing and Replacing the Front Panel Assembly”](#) on page 7-10.
3. Remove the outer and inner covers. Refer to [“Removing the Covers”](#) on page 7-6.
4. On the bottom side of the analyzer, remove the A27–A30 first converters (mixers). This is necessary to gain access to one of the midweb mounting screws. Refer to [“Removing and Replacing the A27, A28, A29, and A30 First Converters \(Mixers\) and Mixer Bias Board”](#) on page 7-52.
5. Remove the A13 (Option 080) frequency offset receiver assembly, if present. Refer to [“Removing and Replacing the A13 Frequency Offset Receiver Assembly”](#) on page 7-24.
6. Remove the A12 source 20. Refer to [“Removing and Replacing the A12 Source 20”](#) on page 7-22.
7. Remove the A11 phase lock board. Refer to [“Removing and Replacing the A11 Phase Lock Board”](#) on page 7-20.
8. Remove the A4 power supply assembly. Refer to [“Removing and Replacing the A4 Power Supply Assembly”](#) on page 7-16.
9. Remove the card cage boards (A6, A8, and A10). Remove A9 (Option 080), if present. Refer to [“Removing and Replacing the A6, A8, A9, and A10 Boards”](#) on page 7-18.

---

**NOTE** This procedure has two parts: removing the midweb and removing the fan from the midweb. You must remove the midweb before removing the fan.

---

### Removing the Midweb

Refer to [Figure 7-34](#).

1. Disconnect the power cable (item ①) for the three fans from the A14 system motherboard.
2. With a T-10 TORX driver, remove the seven midweb mounting screws (item ②). Lift out the midweb.

**Figure 7-34 Midweb Removal**

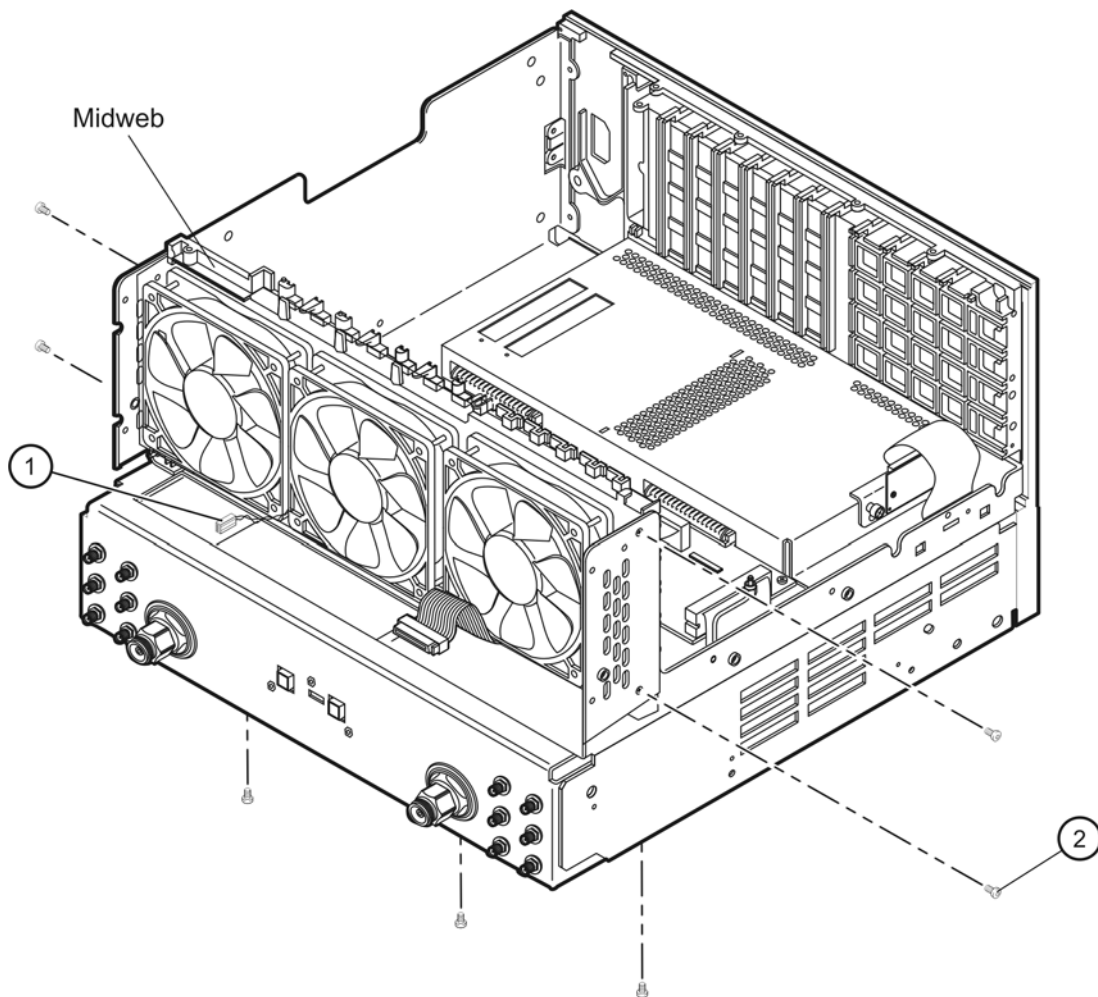

st562a\_new

## Removing the Fan

Refer to [Figure 7-35](#).

1. To remove the fan, it is necessary to remove the four nylon rivets that attach it to the midweb. To do this, use the Pozidriv screwdriver on the nylon screw (item ①) and a small blade screwdriver to stabilize the rivet. Turn and push the rivet out of the rivet hole. Once the four rivets are out, remove the fan.

**Figure 7-35** B1 Fan Removal

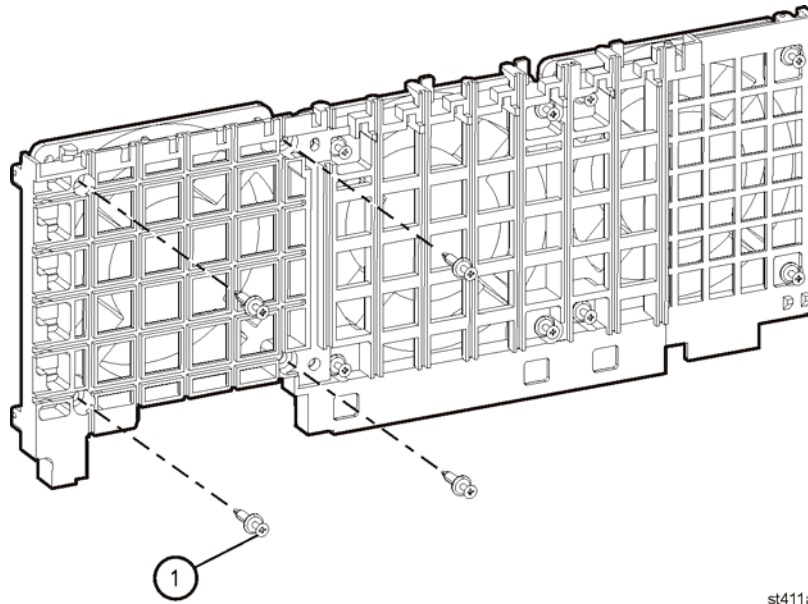

## Replacement Procedure

1. Reverse the order of the removal procedure.
2. Perform the post-repair adjustments, verifications, and performance tests that pertain to this removal procedure. Refer to [Table 7-2 on page 7-82](#).

---

## Removing and Replacing the USB Hub

### Tools Required

- T-10 TORX driver (set to 9 in-lb)
- ESD grounding wrist strap

### Removal Procedure

Refer to [Figure 7-36](#) for this procedure.

1. Disconnect the power cord.
2. With a T-10 TORX driver, remove the six screws (item ①) from the USB hub cover plate.
3. Pull the cover plate away from the analyzer to expose the connecting cable.
4. Disconnect the USB hub cable from the USB hub board.
5. Remove the USB hub from the analyzer.

**Figure 7-36** USB Hub Removal

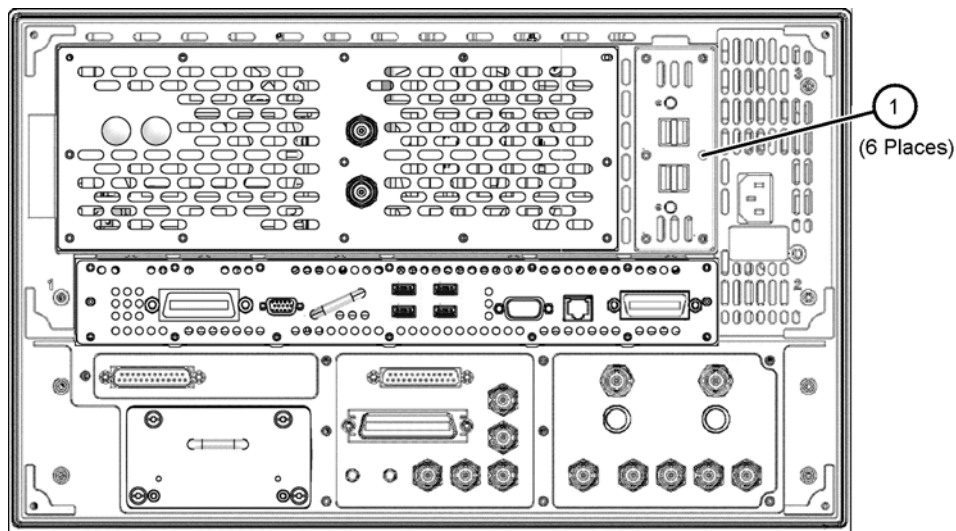

8361\_001\_713

### Replacement Procedure

1. Reverse the order of the removal procedure.
2. Perform the post-repair adjustments, verifications, and performance tests that pertain to this removal procedure. Refer to [Table 7-2](#) on [page 7-82](#).

---

## Removing and Replacing the Lithium Battery

### Tools Required

- T-10 TORX driver (set to 9 in-lb)
- T-20 TORX driver (set to 21 in-lb)
- ESD grounding wrist strap

### Removal Procedure

Refer to [Figure 7-37](#) for this procedure.

1. Disconnect the power cord.
2. Remove the A15 CPU board. Refer to [“Removing and Replacing the A15 CPU Board” on page 7-28](#).
3. Lift the battery (item ①) just enough to free it from its holder and slide it from under the battery clip (item ②). Be careful not to over bend the battery clip as it can be damaged or broken.
4. DO NOT THROW AWAY THE BATTERY. COLLECT IT AS SMALL CHEMICAL WASTE. Refer to [“Lithium Battery Disposal” on page 1-9](#) for additional information on battery disposal.

### Replacement Procedure

1. Reverse the order of the removal procedure following all instructions included with the new battery.
2. Perform the post-repair adjustments, verifications, and performance tests that pertain to this removal procedure. Refer to [Table 7-2 on page 7-82](#).



**Figure 7-37 Lithium Battery Removal**

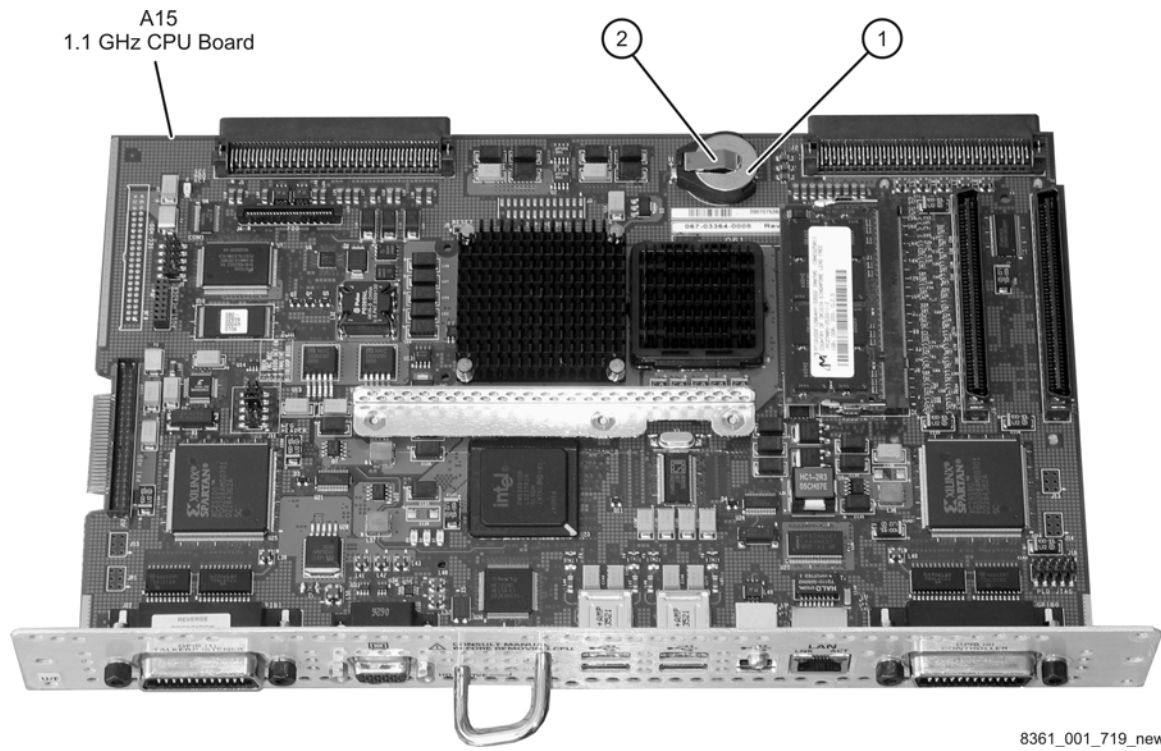

## Post-Repair Procedures

After the replacement of an assembly, you must perform the service procedures in the order listed in [Table 7-2](#).

Procedures referenced in this table are located in [Chapter 3, “Tests and Adjustments,”](#) unless specified otherwise.

**Table 7-2 Related Service Procedures**

Replaced Assembly	Adjustments and Other Procedures	Verification, Performance, and Other Tests and Procedures
A1 keypad assembly	No adjustment needed	<a href="#">Front Panel Keypad and RPG Test</a> in <a href="#">Chapter 4</a>
A2 display assembly	No adjustment needed	<a href="#">A2 Display Test</a> in <a href="#">Chapter 4</a>
A3 front panel interface board	No adjustment needed	<a href="#">Front Panel Keypad and RPG Test</a> and <a href="#">A2 Display Test</a> in <a href="#">Chapter 4</a>
A4 power supply assembly	No adjustment needed	None needed
A6 SPAM board	No adjustment needed	<a href="#">Noise Floor Test</a> <a href="#">Trace Noise Test</a> <a href="#">System Crosstalk Test</a>
A8 fractional-N synthesizer board	<a href="#">LO Power Adjustment</a>	<a href="#">Frequency Accuracy Test</a> <a href="#">The Operator’s Check</a>
A9 fractional-N synthesizer board	<a href="#">Offset LO Adjustment</a>	<a href="#">The Operator’s Check</a>
A10 frequency reference board	<a href="#">10 MHz Frequency Reference Adjustment</a> Restore option data (Refer to <a href="#">“Repairing and Recovering Option Data”</a> in <a href="#">Chapter 8</a> .)	<a href="#">Frequency Accuracy Test</a>
A11 phase lock board	No adjustment needed	<a href="#">Frequency Accuracy Test</a>
A12 source 20	<a href="#">3.8 GHz PMYO Frequency Adjustment</a> <a href="#">Source Calibration Adjustment</a>	<a href="#">Source Power Accuracy Test</a> <a href="#">Source Power Linearity Test</a> <a href="#">Frequency Accuracy Test</a>
A13 frequency offset receiver assembly	<a href="#">Offset LO Adjustment</a>	<a href="#">The Operator’s Check</a>
A14 system motherboard	No adjustment needed	<a href="#">Front Panel Keypad and RPG Test</a> and <a href="#">A2 Display Test</a> in <a href="#">Chapter 4</a> <a href="#">The Operator’s Check</a>
A15 CPU board	No adjustment needed	<a href="#">The Operator’s Check</a>
A16 test set motherboard	Reinstall the serial number. (Refer to <a href="#">“Installing or Changing a Serial Number”</a> in <a href="#">Chapter 8</a> .) Re-enable all hardware options. (Refer to <a href="#">“Enabling or Removing Options”</a> in <a href="#">Chapter 8</a> .)	<a href="#">The Operator’s Check</a> <a href="#">System Crosstalk Test</a>

**Table 7-2 Related Service Procedures (Continued)**

Replaced Assembly	Adjustments and Other Procedures	Verification, Performance, and Other Tests and Procedures
A17 LOMA 10	LO Power Adjustment	Frequency Accuracy Test The Operator's Check
A18 MA 20	LO Power Adjustment	Frequency Accuracy Test The Operator's Check
A19 splitter	LO Power Adjustment	The Operator's Check
A20 LODA	LO Power Adjustment	The Operator's Check
A21 SOMA 50 (E8363C/E8364C only)	Source Calibration Adjustment Phase Lock IF Gain Adjustment	Source Power Accuracy Test Source Power Linearity Test Frequency Accuracy Test
A22 switch splitter	Source Calibration Adjustment Phase Lock IF Gain Adjustment	Source Power Accuracy Test Calibration Coefficient Test
A23 and A24 detectors (E8363C/E8364C only) or 30-dB fixed attenuators (E8362C only)	Source Calibration Adjustment Phase Lock IF Gain Adjustment	Source Power Linearity Test Calibration Coefficient Test
A25 and A26 test port couplers	Source Calibration Adjustment Phase Lock IF Gain Adjustment	Source Power Accuracy Test Calibration Coefficient Test
A27, A28, A29, and A30 first converters (mixers)	Phase Lock IF Gain Adjustment Receiver Calibration Adjustment	Receiver Compression Test Noise Floor Test Calibration Coefficient Test System Crosstalk Test Dynamic Accuracy Test
A31, A32, A33, and A34 receiver modules	Phase Lock IF Gain Adjustment Receiver Calibration Adjustment	Receiver Compression Test Noise Floor Test Calibration Coefficient Test System Crosstalk Test Dynamic Accuracy Test
A35 receiver motherboard	Receiver Calibration Adjustment	The Operator's Check
A36 and A37 60-dB source step attenuators	Source Calibration Adjustment Phase Lock IF Gain Adjustment	Source Power Accuracy Test System Crosstalk Test Calibration Coefficient Test
A38 and A39 bias tees	Source Calibration Adjustment Phase Lock IF Gain Adjustment	Source Power Accuracy Test Calibration Coefficient Test
A41 hard disk drive	Restore previously saved receiver calibration data <sup>a</sup> (or perform Receiver Calibration Adjustment)	Read and write to the drive

**Table 7-2 Related Service Procedures (Continued)**

Replaced Assembly	Adjustments and Other Procedures	Verification, Performance, and Other Tests and Procedures
A43 and A44 35-dB receiver step attenuators	<a href="#">Receiver Calibration Adjustment</a>	The Operator's Check System Crosstalk Test
A45 and A46 reference channel transfer switches	<a href="#">Source Calibration Adjustment</a> <a href="#">Phase Lock IF Gain Adjustment</a> <a href="#">Receiver Calibration Adjustment</a>	The Operator's Check System Crosstalk Test
A47 and A48 couplers	<a href="#">Source Calibration Adjustment</a> <a href="#">Phase Lock IF Gain Adjustment</a> <a href="#">Receiver Calibration Adjustment</a>	The Operator's Check System Crosstalk Test
A49 IF multiplexer board	<a href="#">Phase Lock IF Gain Adjustment</a>	The Operator's Check
B1 fan	No adjustment needed	Check for fan operation
USB hub	No adjustment needed	<a href="#">Checking the USB Ports</a>
Battery	No adjustment needed	None

- a. If a backup copy of receiver calibration data from the faulty disk drive is available, it can be copied to the new disk drive. If not, new data must be generated by performing the "[Receiver Calibration Adjustment](#)."

---

## **8 General Purpose Maintenance Procedures**

---

## Information in This Chapter

### Chapter Eight at-a-Glance

Section Title	Summary of Content	Start Page
<a href="#">Error Terms</a>	How to use error terms as a preventive maintenance and troubleshooting tool.	<a href="#">page 8-3</a>
<a href="#">Option Enable Utility</a>	How to use the option enable utility to: <ul style="list-style-type: none"><li>• enable options that have been added to your analyzer,</li><li>• repair lost or damaged option data,</li><li>• install or change a serial number.</li></ul>	<a href="#">page 8-15</a>
<a href="#">Firmware Upgrades</a>	How to check your analyzer's current firmware revision and where to locate firmware upgrades.	<a href="#">page 8-19</a>
<a href="#">Operating System Recovery</a>	Where to find the information on recovering from a damaged operating system.	<a href="#">page 8-20</a>
<a href="#">Correction Constants</a>	How to store correction constants after making adjustments to your analyzer.	<a href="#">page 8-21</a>

---

## Error Terms

### Using Error Terms as a Diagnostic Tool

By examining error terms, you can monitor system performance for preventive maintenance and troubleshooting purposes.

The magnitude and shape of the error terms are affected by:

- calibration kit devices
- cables
- adapters and accessories
- the assemblies from the signal separation group of the analyzer

Calibration kit devices, cables, and adapters and accessories are the most common cause of error term anomalies. Make sure of the following:

- Connectors must be clean, gaged, and within specification.
- Use proper connection technique during measurement and calibration. For information on connection technique and on cleaning and gaging connectors, refer to [“Review the Principles of Connector Care” on page 3-5](#) or to the calibration kit’s user’s and service guide.

### Preventive Maintenance

If you print or plot the error terms at set intervals (weekly, monthly and so forth), you can compare current error terms to these records. A stable system should generate repeatable error terms over long intervals, (for example, six months). Look for the following:

- A long-term trend often reflects drift, connector and cable wear, or gradual degradation, indicating the need for further investigation and preventive maintenance. Yet, the system may still conform to specifications. The cure is often as simple as cleaning and gaging connectors and cables.
- A sudden shift in error terms may indicate the need for troubleshooting.

### Troubleshooting

You can use the error terms as a tool to isolate faulty assemblies in the signal separation group of your analyzer. You can compare the current values to preventive maintenance records or to the typical values listed in [Table 8-1 on page 8-11](#).

To find assemblies related to error term failures, refer to error term descriptions in [“Error Term Data” on page 8-10](#). Each plot description lists common assemblies related to each error term. Identify the assembly and refer to [Chapter 4, “Troubleshooting”](#).

---

**NOTE** Always suspect calibration devices, cables, or improper connector maintenance as the primary cause of an error term anomaly.

---

### Performing Measurement Calibration

A calibration must be performed to allow the analyzer to calculate the error terms before they can be used

as a tool:

---

**CAUTION** Perform the following procedure only at a static-safe workstation, and wear a grounded wrist strap.

This is important. If not properly protected against, electrostatic discharge can seriously damage your analyzer, resulting in costly repair.

To reduce the chance of electrostatic discharge, follow all of the recommendations outlined in [“Electrostatic Discharge Protection”](#) on page 1-6, when performing the following calibration.

---

1. Connect a test cable to Port 2.
2. Perform a full 2-port calibration, **FULL SOLT 2-Port**. Refer to embedded help in the analyzer if necessary.

### Using Flowgraphs to Identify Error Terms

Flowgraphs are a graphical representation of signal flow through the measurement path. The flowgraphs in [Figure 8-1](#), [Figure 8-2](#), [Figure 8-3](#), and [Figure 8-4](#) illustrate the error terms associated with measurement calibration for 1-port, 2-port, 3-port, and 4-port configurations respectively.

**Figure 8-1 Flowgraph of One-Port Error Terms for Port 1**

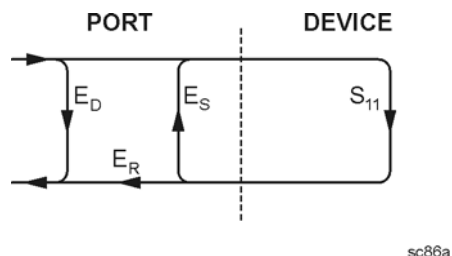

where:

E = Error term

Subscript:

D = Directivity

S = Source Match

R = Reflection Tracking

The error terms are the same for a one port measurement on Port 2 ( $S_{22}$ ).



**Figure 8-2 Flowgraph of Two-Port Error Terms**

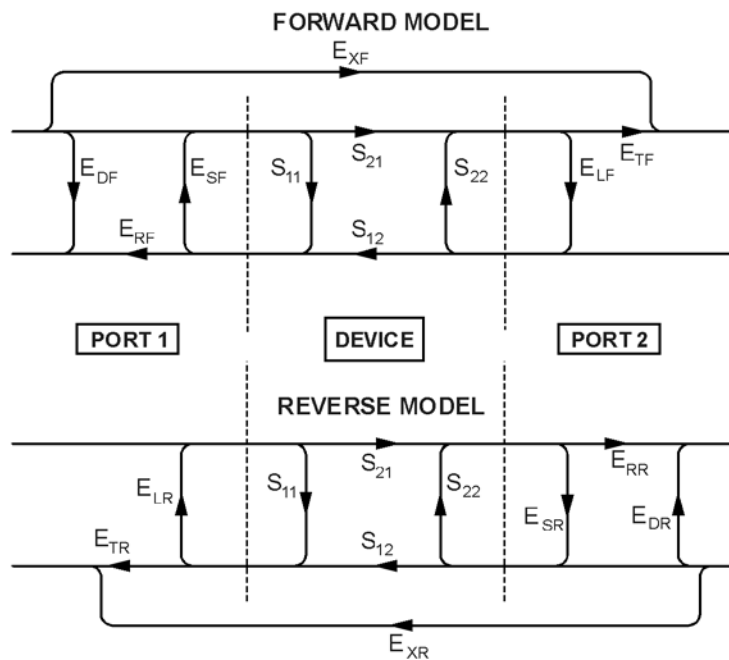

sc87a.cdr

where:

E = error term

1st Subscript:

- D = Directivity
- S = Source Match
- R = Reflection Tracking
- X = Crosstalk (Isolation)
- L = Load Match
- T = Transmission Tracking

2nd Subscript:

- F = forward measurement (Port 1 to Port 2)
- R = reverse measurement (Port 2 to Port 1)

**Figure 8-3 Flowgraph of Three-Port Error Terms**

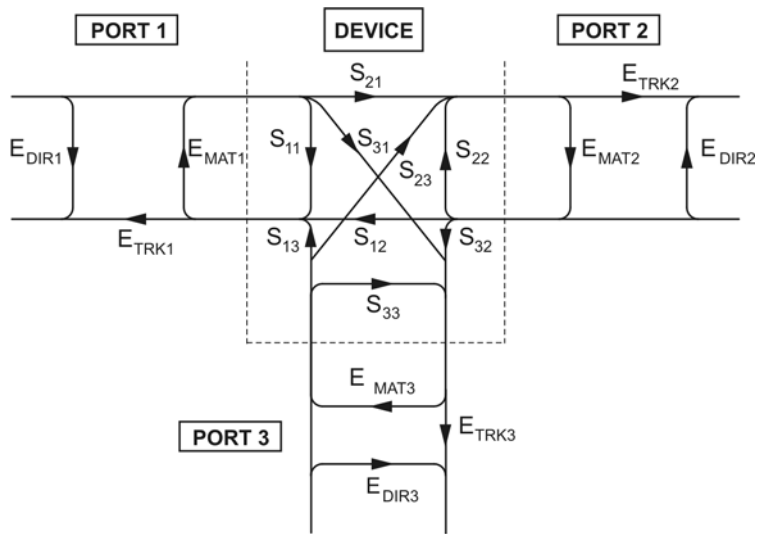

sz348a

where:

- E = error term
- DIR = Directivity
- MAT = Forward Source Match and Reverse Load Match
- TRK = Forward Reflection Tracking and Reverse Transmission Tracking

For the case of a full 3-port calibration, port 1 has three Match error terms:

- S11 source match
  - S12 load match
  - S13 load match
- and three Tracking error terms:
- S11 reflection tracking
  - S12 transmission tracking
  - S13 transmission tracking

There are six isolation terms not shown.

**Figure 8-4 Flowgraph of Four-Port Error Terms**

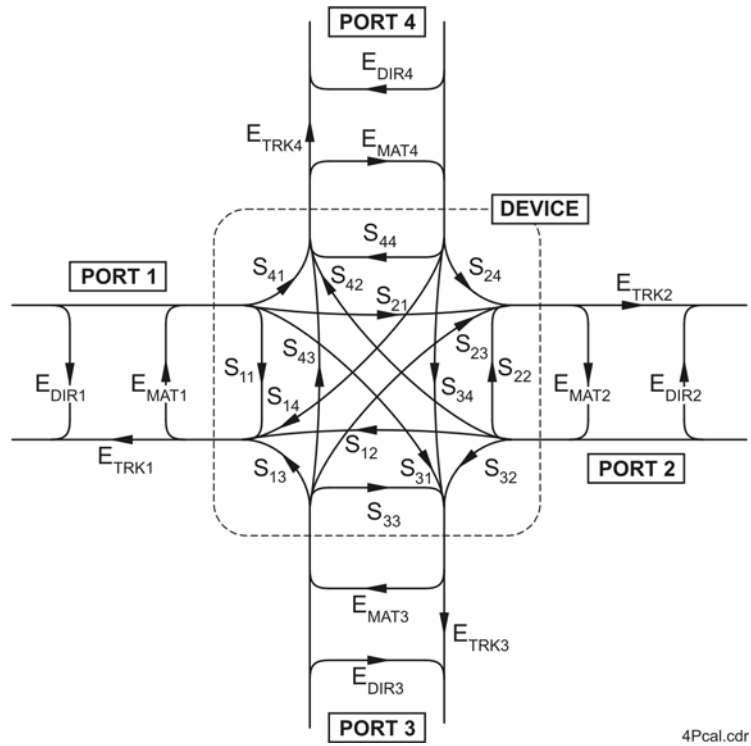

4Pcal.cdr

where:

E = error term

DIR = Directivity

MAT = Forward Source Match and Reverse Load Match

TRK = Forward Reflection Tracking and Reverse Transmission Tracking

For the case of a full 4-port calibration, port 1 has four Match error terms:

S11 source match

S12 load match

S13 load match

S14 load match

and four Tracking error terms:

S11 reflection tracking

S12 transmission tracking

S13 transmission tracking

S12 transmission tracking

There are eight isolation (crosstalk) terms not shown.

## Accessing Error Terms

Error terms can be accessed either manually or programmatically:

### Manually

- “Front Panel Access to Error Terms” on page 8-8

### Programmatically

- “GPIB Access to Error Terms” on page 8-9
- “COM/DCOM Access to Error Terms” on page 8-9

## Manual Access to Error Terms

### Front Panel Access to Error Terms

---

**NOTE** Ensure the calibration correction is active by making sure that **Correction on/OFF** has a check-mark in the **Calibration** menu.

---

To access the error terms from the front panel, perform the following steps:

1. In the **System** menu, point to **Service, Utilities**, and then click **Cal Set Viewer**.  
The **Cal Set Viewer** toolbar appears directly above the trace window.
2. In the **Cal Set** list, select the desired cal set.
3. Click the **Standards/ETerms** button to toggle between viewing the raw measurement data from the standard or the corrected error term data. Note that the title of the center box in the tool bar will toggle between **Standard** and **Error Term**.
4. In the **Standard** or **Error Term** list, select the standard or error term to view. Click the **View** check box.
5. Compare the displayed measurement trace to the equivalent data trace plots that start in “**Error Term Data**” on page 8-10, to previously measured data, or to the uncorrected performance specifications listed in [Table 8-1](#) on page 8-11.
6. Print numerical data or print a plot of the measurement results.

## **Programmatic Access to Error Terms**

### **GPIB Access to Error Terms**

You can access error terms by way of GPIB with Standard Commands for Programmable Instruments (SCPI).

For more information on GPIB and SCPI, refer to the embedded help in the analyzer. Type in keyword “errors, systematic” in the index.

### **COM/DCOM Access to Error Terms**

You can access error terms by way of Component Object Model (COM) or Distributed Component Object Model (DCOM) software architecture.

For more information on COM and DCOM, refer to the embedded help in the analyzer. Type in keyword “errors, systematic” in the index.

## Error Term Data

The error term descriptions in this section include the following information:

- a table of the error terms
- description and significance of each error term
- measurements affected by each error term
- typical cause of failure for each error term

The same description applies to both the forward (F) and reverse (R) terms.

**IMPORTANT** Data are listed here as a convenience only. Detailed instrument specifications are listed in the embedded help in the network analyzer.

**Table 8-1 Error Term Data<sup>a</sup>**

Parameter	Frequency Range						
	10 MHz to 45 MHz <sup>b</sup>	45 MHz to 2 GHz	2 GHz to 10 GHz	10 GHz to 20 GHz	20 GHz to 40 GHz	40 GHz to 45 GHz	45 GHz to 50 GHz
Directivity	>22 dB	>24 dB	>22 dB	>16 dB	>16 dB	>15 dB	>13 dB
Source Match							
Standard	>17 dB	>23 dB	>16 dB	>14 dB	>10 dB	>9 dB	>5.5 dB
Option UNL, 014, or UNL & 014	>12 dB	>18 dB	>14 dB	>12 dB	>8 dB	>7 dB	>4 dB
Load Match							
Standard	>20 dB	>23 dB	>14 dB	>10 dB	>9 dB	>9 dB	>7 dB
Option UNL, 014, or UNL & 014	>12 dB	>17 dB	>13 dB	>10 dB	>9 dB	>8 dB	>6 dB
Reflection Tracking <sup>b</sup>	±1.5 dB	±1.5 dB	±1.5 dB	±1.5 dB	±1.5 dB	±2.0 dB	±2.0 dB
Transmission Tracking <sup>b, c</sup>	±2.0 dB	±1.5 dB	±2.0 dB	±2.5 dB	±3.5 dB	±4.0 dB	±4.5 dB
Crosstalk (Isolation)							
Standard	-85 dB	-100 dB <sup>e</sup>	-110 dB	-110 dB	-108 dB	-105 dB	-100 dB
Option UNL or 014	-85 dB	-100 dB <sup>e</sup>	-109 dB	-109 dB	-106 dB	-103 dB	-98 dB
Option UNL & 014	-85 dB	-98 dB <sup>e</sup>	-108 dB	-107 dB	-104 dB	-100 dB	-95 dB
Option 080 enabled <sup>b, d</sup>	-85 dB	-108 dB <sup>f</sup>	-115 dB	-120 dB	-115 dB	-112 dB	-105 dB

- a. Uncorrected system performance. The values in the table apply over an environmental temperature of 23 °C ±3 °C, with less than 1 °C deviation from the calibration temperature.
- b. Typical performance.
- c. Transmission tracking performance is strongly dependent on cable used. These typical specifications are set based on the use of Agilent through cable part number 85133-60016.
- d. 0 Hz offset.
- e. The value is -85 dB for frequencies below 1 GHz.
- f. The value is -95 dB from 45 MHz to 1 GHz.

**If Error Terms Seem Worse than Expected**

To verify that the system still conforms to specifications, perform a system verification. Refer to [Chapter 3, “Tests and Adjustments”](#).

**Directivity (E<sub>DF</sub> and E<sub>DR</sub>)**

E<sub>DF</sub> and E<sub>DR</sub> are the uncorrected forward and reverse directivity error terms of the system. The directivity

error of the test port is determined by measuring the  $S_{11}$  and  $S_{22}$  reflection of the calibration kit load. The load has a much better return loss specification than does the uncorrected test port. Therefore, any power detected from this measurement is assumed to be from directivity error.

The measurements most affected by directivity errors are measurements of low reflection devices.

**Typical Cause of Failure** The *calibration kit load* is the most common cause of directivity specification failure.

If the load has been gaged and its performance independently verified, suspect the analyzer *test port coupler*.

To troubleshoot, refer to [“Checking the Signal Separation Group” on page 4-38](#).

### Source Match ( $E_{SF}$ and $E_{SR}$ )

$E_{SF}$  and  $E_{SR}$  are the forward and reverse uncorrected source match terms of the driven port. They are obtained by measuring the reflection ( $S_{11}$ ,  $S_{22}$ ) of an open, and a short that are connected directly to the ports. Source match is a measure of the match of the coupler, as well as the match between all components from the source to the output port.

The measurements most affected by source match errors are reflection and transmission measurements of highly reflective DUTs.

**Typical Cause of Failure** The *calibration kit open or short* is the most common cause of source match specification failure.

If the open or short performance has been independently verified, then suspect the analyzer *switch splitter, step attenuator, or coupler*.

To troubleshoot, refer to [“Checking the Signal Separation Group” on page 4-38](#).

### Load Match ( $E_{LF}$ and $E_{LR}$ )

Load match is a measure of the impedance match of the test port that terminates the output of a 2-port device. The match of test port cables is included in this response. Load match error terms are characterized by measuring the  $S_{11}$  and  $S_{22}$  responses of a “thru” configuration during the calibration procedure.

The measurements most affected by load match errors are all transmission measurements, and reflection measurements of a low insertion loss two-port device, such as an airline.

**Typical Cause of Failure** The *calibration kit load or a bad “thru” cable* is the most common cause of load match specification failure.

If the load and cable performance are independently verified, then suspect the analyzer *test port coupler, step attenuator, or the test receiver* at the bad port.

To troubleshoot, refer to [“Checking the Receiver Group” on page 4-42](#) or to [“Checking the Signal Separation Group” on page 4-38](#).

### Reflection Tracking ( $E_{RF}$ and $E_{RR}$ )

Reflection tracking is the difference between the frequency response of the reference path (R1 or R2path) and the frequency response of the reflection test path (A or B input path). These error terms are characterized by measuring the reflection ( $S_{11}$ ,  $S_{22}$ ) of the open and the short during the measurement



calibration.

All reflection measurements are affected by the reflection tracking errors.

**Typical Cause of Failure** The *calibration kit open or short* is the most common cause of reflection tracking specification failure.

If the open or short performance has been independently verified, suspect the following:

- If both  $E_{RF}$  and  $E_{RR}$  fail
  - suspect the analyzer *switch splitter*
- If one of the track term specification fails
  - suspect the *coupler, step attenuator, or the test receiver* of the failed port

To troubleshoot, refer to [“Checking the Receiver Group” on page 4-42](#) or to [“Checking the Signal Separation Group” on page 4-38](#).

### Transmission Tracking ( $E_{TF}$ and $E_{TR}$ )

Transmission tracking is the difference between the frequency response of the reference path (including the R input) and the frequency response of the transmission test path (including the A or B input) while measuring transmission. The response of the test port cables is included. These terms are characterized by measuring the transmission ( $S_{21}$ ,  $S_{12}$ ) of the “thru” configuration during the measurement calibration.

All transmission measurements are affected by transmission tracking errors.

**Typical Cause of Failure** The *test port cable* is the most common cause of transmission tracking specification failure.

If the test port cable performance has been independently verified, suspect the following:

- If both  $E_{TF}$  and  $E_{TR}$  fail
  - suspect the analyzer *switch splitter*
- If one of the track term specification fails
  - suspect the *coupler, step attenuator, or the test receiver* of the failed port

To troubleshoot, refer to [“Checking the Receiver Group” on page 4-42](#) or to [“Checking the Signal Separation Group” on page 4-38](#).

### Isolation ( $E_{XF}$ and $E_{XR}$ )

Isolation, or crosstalk, is the uncorrected forward and reverse isolation error terms that represent leakage between the test ports and the signal paths. The isolation error terms are characterized by measuring transmission ( $S_{21}$ ,  $S_{12}$ ) with loads attached to both ports during the measurement calibration. Isolation errors affect transmission measurements primarily where the measured signal level is very low.

The measurements most affected by isolation error terms are DUTs with large insertion loss. Since these terms are low in magnitude, they are usually noisy (not very repeatable).

**Typical Cause of Failure** A loose cable connection or leakage between components in the test set are the most likely cause of isolation problems.

After verifying the cable and its connections, suspect the analyzer *switch splitter, step attenuator, coupler, or receivers, and associated cabling*.

To troubleshoot, refer to [“Checking the Receiver Group” on page 4-42](#) or to [“Checking the Signal Separation Group” on page 4-38](#).

---

## Option Enable Utility

### Accessing the Option Enable Utility

To start the option enable utility:

- On the **System** menu, point to **Service**, and then click **Option Enable**.
- The dialog box illustrated in [Figure 8-5](#) is displayed.

**Figure 8-5** Option Enable Dialog Box

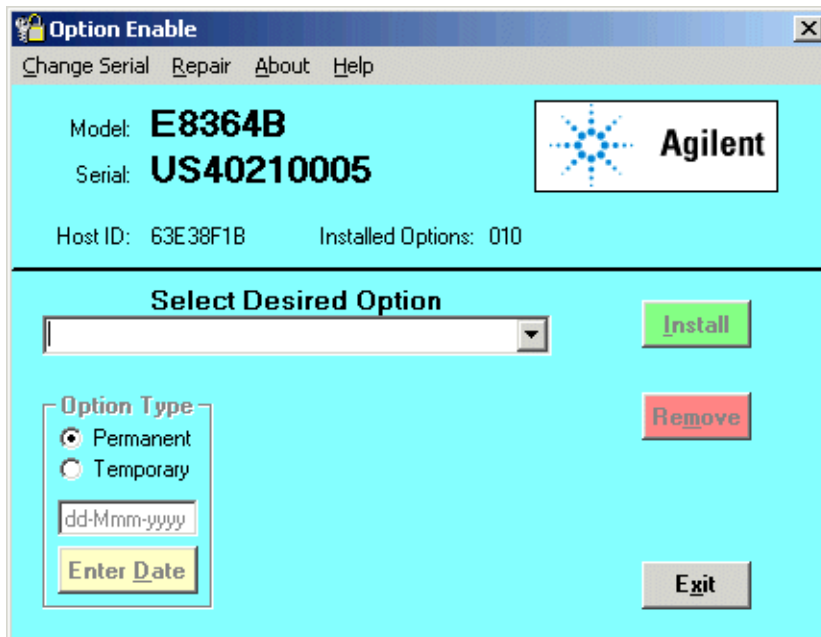

### Option Entitlement Certificate

If you have received an “Option Entitlement Certificate”, follow the instructions on the certificate, under “HOW TO USE THIS CERTIFICATE:”, to obtain license key(s) for the option(s) listed on the certificate. See the important note below.

---

**NOTE** When upgrading from one model number to another, a new option entitlement certificate will be issued. When this certificate is redeemed for a license key, the automated system will ask for the instrument's Host ID. Be sure to use the new Host ID that is associated with the new model number. Using the current Host ID will cause a license to be generated that will not work with the instrument. To determine the new Host ID, use the utility at the below listed web site with the new model number.

<http://na.tm.agilent.com/pna/upgrades.html>

## Enabling or Removing Options

There are two types of options:

- **Hardware:** Hardware options involve adding additional hardware to the analyzer. After the proper hardware has been installed in the analyzer, the option can be enabled using the option enable utility.  
It is necessary to re-enable all hardware options if the test set motherboard is replaced.
- **Software:** Software options add features or functionality to the analyzer without the need for additional hardware. These options are enabled using a special keyword. They are enabled using the option enable utility.  
It is necessary to backup all installed software options if the frequency reference board is replaced.

---

**NOTE** Some applications require a license key that is provided by Agilent. If you do not have the required license key, contact Agilent for assistance. Refer to [“Contacting Agilent” on page 2-12.](#)

---

To enable or remove an option:

1. Start the option enable utility. Refer to [“Accessing the Option Enable Utility” on page 8-15.](#)
2. Click the arrow in the **Select Desired Option** box. A list of available options, similar to the list below, will appear.
  - 010 - Time Domain
  - UNL - Bias Tees w/Atten
  - 014 - Configurable Test Set
  - 016 - Receiver Attenuators
  - 080 - Frequency Offset Mode
  - 081 - Reference Transfer Switch
  - 083 - Mixer Measurement Appl
  - ??? - Enter Unlisted Option
3. Click on the option that you wish to either enable or remove, and then click **Enable** or **Remove**, whichever is appropriate.
4. If the desired option is not available in the list, select **Enter Unlisted Option**. A dialog box appears that will allow you to enter the option number. Enter the option number and follow the instructions on the display.

## Repairing and Recovering Option Data

License, option, and model number data are stored in an EEPROM on the frequency reference board and written into the gen.lic file on the hard disk drive. If the data stored in either of these items is lost, it can be recovered from the other item.

---

**NOTE** If the data on both the hard disk drive and the frequency reference board is lost, it can not be recovered. Contact Agilent for assistance. Refer to [“Contacting Agilent” on page 2-12.](#)

---

### Recovery of Data After Repair

- If the frequency reference board is replaced, use the **Repair** selection to recover data that has been lost as a result of the repair:
  1. Select **Repair** from the **Option Enable** menu bar (see [Figure 8-5 on page 8-15](#)).
  2. Click the **Freq Ref board has been replaced** check box.
  3. Click **Begin Repair**. The data is written from the gen.lic file into the EEPROM.
- If the hard disk drive is replaced, a new gen.lic file is automatically created when the **Network Analyzer** application starts, by retrieving the data from the EEPROM.

### Recovery of Data if Option or Model Numbers are Incorrect

If the analyzer option or model numbers are not listed correctly on the analyzer display, in either the Option Enable Dialog Box or the About Network Analyzer display, you should regenerate the options license file, gen.lic:

1. Exit the **Network Analyzer** application.
2. Remove (or rename) the existing gen.lic file:
  - a. Open **Windows Explorer** and navigate to C:\Program Files\Agilent\Network Analyzer.
  - b. Delete (or rename) gen.lic.
3. Exit the **Windows Explorer** application.
4. Open the **Network Analyzer** application. The application will generate a new gen.lic file when it starts.
5. Check the option listing:
  - a. On the **System** menu, point to **Service**, and then click **Option Enable**, or
  - b. On the **Help** menu, click **About Network Analyzer**.

---

**NOTE** If the options are still not listed correctly, contact Agilent for assistance. Refer to [“Contacting Agilent” on page 2-12.](#)

---

## Installing or Changing a Serial Number

It is necessary to reinstall the instrument serial number if the test set motherboard is replaced.

---

**IMPORTANT** Use extreme care when entering the serial number, as only one attempt is allowed.

---

1. To change a serial number, select **Change Serial** from the **Option Enable** menu bar (see [Figure 8-5 on page 8-15](#)). The current serial number is displayed. If no serial number has previously been entered, the word "NONE" will be displayed.
2. VERY CAREFULLY, type the new serial number into the space provided and then click **Change**.
3. If an error is made in entering the serial number, obtain a clear code from Agilent, enter the clear code in the space provided, and then click **Clear**. The correct serial number can then be entered.

---

**NOTE** To change an incorrect serial number, a clear-code password is required. Contact Agilent to obtain the clear-code. Refer to ["Contacting Agilent" on page 2-12](#).

---

## Firmware Upgrades

### How to Check the Current Firmware Version

1. With the **Network Analyzer** application running, click **Help, About Network Analyzer**.  
A dialog box showing the current installed Application Code Version is displayed.
2. To determine if a firmware update is available, proceed to "[Downloading from the Internet](#)."

### Downloading from the Internet

If your network analyzer is connected to the Internet, there are two methods available for checking the availability of, and downloading, new firmware:

- Download directly from: <http://www.agilent.com/find/pna>. (Select your analyzer's model number in this website to view available upgrades.)
- On the **System** menu, point to **Service**, and then click **AgileUpdate**. **AgileUpdate** compares the firmware revision currently installed in your network analyzer to the latest version available and assists you in downloading and installing the most recent version.

## **Operating System Recovery**

### **Recovering from Hard Disk Drive Problems**

If you suspect that you have a hard disk drive problem, go to the “Hard Drive Recovery” link on the Agilent PNA Series: Service & Support Home Page on the Internet.

The URL for the Agilent PNA Series: Service & Support Home Page is:

<http://na.tm.agilent.com/pna/>

The URL for the Hard Drive Recovery page is:

<http://na.tm.agilent.com/pna/hdrecovery.html>



## Correction Constants

The analyzer stores many correction constants in non-volatile EEPROM memory. These constants enable the analyzer to produce accurate, leveled source signals and receive clean test signals.

### Storing Correction Constants

After performing any adjustment listed on [page 3-38](#) in this manual, store the correction constants to a backup file on the analyzer hard disk drive by performing these steps:

- Navigate to the EEPROM Backup Utility, located at:  
C:\Program Files\Agilent\Network Analyzer\Service\eebackup.exe
- **Run** the program.
- Click **Backup EEPROM**.
- Click **Exit** when the program has finished.



## Numerics

### 1284-C port

rear panel connector, 5-32  
troubleshooting, 4-18

### 30-dB fixed attenuators

illustrated, 6-23, 6-59, 6-61, 6-63, 6-65  
part number, 6-22  
removal and replacement procedure,  
7-46

### 35-dB step attenuators

illustrated, 6-39, 6-41, 6-45  
operation, 5-18  
part number, 6-38, 6-40, 6-42, 6-58,  
6-62

### 60-dB step attenuators

illustrated, 6-27, 6-29, 6-35, 6-37,  
6-39, 6-41, 6-45, 6-51, 6-53, 6-55,  
6-57, 6-59, 6-61, 6-63, 6-65  
operation, 5-18  
part number, 6-26, 6-28, 6-34, 6-38,  
6-40, 6-42, 6-50, 6-54, 6-58, 6-62

### 8.33 MHz IF IN connectors

operation, 5-26

### 897, option

built-in tests for commercial  
calibration, 2-6

### 898, option

built-in tests for standards compliant  
calibration, 2-6

## A

### A channel

attenuator  
removal and replacement, 7-70  
troubleshooting, 4-26  
typical power output, 4-38

### A receiver module

troubleshooting, 4-43

### A trace

troubleshooting, 4-26, 4-29

### A1 keypad assembly

illustrated, 6-13  
operation, 5-30  
part number, 6-12  
removal and replacement  
illustrated, 7-13  
procedure, 7-14  
troubleshooting, 4-12

### A10 frequency reference board

illustrated, 6-15, 6-19  
operation, 5-9  
part number, 6-14, 6-18  
removal and replacement, 7-18  
illustrated, 7-19  
troubleshooting, 4-32, 4-33, 4-44

### A11 phase lock board

illustrated, 6-15, 6-19

operation, 5-10  
part number, 6-14, 6-18  
removal and replacement, 7-20  
illustrated, 7-21

### A12 source 20

illustrated, 6-15, 6-19  
operation, 5-10  
part numbers, 6-14, 6-18  
removal and replacement, 7-22  
illustrated, 7-23  
troubleshooting, 4-32  
any band, 4-46

### A13 frequency offset receiver

illustrated, 6-19  
operation, 5-24  
part number, 6-18  
removal and replacement, 7-24  
illustrated, 7-25  
troubleshooting, 4-47

### A14 system motherboard

illustrated, 6-15, 6-19  
operation, 5-30, 5-33  
part number, 6-14, 6-18  
removal and replacement, 7-26  
illustrated, 7-27  
troubleshooting, 4-9, 4-11  
voltage checks, 4-8

### A15 CPU board

illustrated, 6-15, 6-19  
operation, 5-31  
part number, 6-14, 6-18  
removal and replacement, 7-28  
illustrated, 7-30  
troubleshooting, 4-9, 4-17

### A16 test set motherboard

illustrated, 6-23  
operation, 5-12  
part number, 6-22  
removal and replacement, 7-32  
illustrated, 7-33  
troubleshooting, 4-42, 4-43

### A17 LOMA 10

illustrated, 6-23  
operation, 5-9  
part number, 6-22  
removal and replacement  
illustrated, 7-35  
procedure, 7-34  
troubleshooting, 4-34

### A18 MA 20

illustrated, 6-23  
operation, 5-9  
part number, 6-22  
removal and replacement  
illustrated, 7-37  
procedure, 7-36  
troubleshooting, 4-37

### A19 splitter

illustrated, 6-23  
operation, 5-9  
part number, 6-22  
removal and replacement  
illustrated, 7-39  
procedure, 7-38

### A2 display assembly

illustrated, 6-13  
operation, 5-30  
part number, 6-12  
removal and replacement  
illustrated, 7-13  
procedure, 7-13  
troubleshooting, 4-12

### A20 LODA

illustrated, 6-23  
operation, 5-9  
part number, 6-22  
removal and replacement  
illustrated, 7-41  
procedure, 7-40  
troubleshooting, 4-37

### A21 SOMA 50

illustrated, 6-23  
operation, 5-11  
part number, 6-22  
removal and replacement  
illustrated, 7-43  
procedure, 7-42  
troubleshooting, 4-32

### A22 switch splitter

illustrated, 6-23  
operation, 5-16  
part number, 6-22  
removal and replacement  
illustrated, 7-45  
procedure, 7-44  
troubleshooting, 4-39, 4-40

### A23 channel R1 detector

illustrated, 6-23  
operation, 5-17  
Option 014/080/081  
illustrated, 6-47, 6-49  
Option 081  
part number, 6-46  
part number, 6-22  
removal and replacement  
illustrated, 7-49  
procedure, 7-48

### A24 channel R2 detector

illustrated, 6-23  
operation, 5-17  
part number, 6-22  
removal and replacement  
illustrated, 7-49  
procedure, 7-48

### A25 test port 1 coupler

illustrated, 6-23

- operation, 5-17
- part number, 6-22
- removal and replacement
  - illustrated, 7-51
  - procedure, 7-50
- troubleshooting, 4-39, 4-40
- A26 test port 2 coupler**
  - illustrated, 6-23
  - operation, 5-17
  - part number, 6-22
  - removal and replacement
    - illustrated, 7-51
    - procedure, 7-50
  - troubleshooting, 4-39, 4-40
- A27 channel A first converter**
  - illustrated, 6-23
  - operation, 5-21
  - part number, 6-22
  - removal and replacement
    - illustrated, 7-53
    - procedure, 7-52
  - troubleshooting, 4-42
- A28 channel R1 first converter**
  - illustrated, 6-23
  - operation, 5-21
  - part number, 6-22
  - removal and replacement
    - illustrated, 7-53
    - procedure, 7-52
  - troubleshooting, 4-42
- A29 channel R2 first converter**
  - illustrated, 6-23
  - operation, 5-21
  - part number, 6-22
  - removal and replacement
    - illustrated, 7-53
    - procedure, 7-52
  - troubleshooting, 4-42
- A3 front panel interface board**
  - illustrated, 6-13
  - operation, 5-30
  - part number, 6-12
  - removal and replacement
    - illustrated, 7-13
    - procedure, 7-14
  - troubleshooting, 4-12
- A30 channel B first converter**
  - illustrated, 6-23
  - operation, 5-21
  - part number, 6-22
  - removal and replacement
    - illustrated, 7-53
    - procedure, 7-52
  - troubleshooting, 4-42
- A31 channel A receiver module**
  - illustrated, 6-23
  - operation, 5-21
  - part number, 6-22
  - removal and replacement
    - illustrated, 7-55
    - procedure, 7-54
  - troubleshooting, 4-43
- A32 channel R1 receiver module**
  - illustrated, 6-23
  - operation, 5-21
  - part number, 6-22
  - removal and replacement
    - illustrated, 7-55
    - procedure, 7-54
  - troubleshooting, 4-43
- A33 channel R2 receiver module**
  - illustrated, 6-23
  - operation, 5-21
  - part number, 6-22
  - removal and replacement
    - illustrated, 7-55
    - procedure, 7-54
  - troubleshooting, 4-43
- A34 channel B receiver module**
  - illustrated, 6-23
  - operation, 5-21
  - part number, 6-22
  - removal and replacement
    - illustrated, 7-55
    - procedure, 7-54
  - troubleshooting, 4-43
- A35 receiver motherboard**
  - illustrated, 6-23
  - operation, 5-23
  - part number, 6-22
  - removal and replacement
    - illustrated, 7-57
    - procedure, 7-56
  - troubleshooting, 4-43
- A36 port 1 step attenuator**
  - illustrated, 6-27, 6-29, 6-35, 6-37, 6-39, 6-41, 6-45, 6-51, 6-53, 6-55, 6-57, 6-59, 6-61, 6-63, 6-65
  - operation, 5-18
  - part number, 6-26, 6-28, 6-34, 6-38, 6-40, 6-42, 6-50, 6-54, 6-58, 6-62
  - removal and replacement
    - illustrated, 7-59
    - procedure, 7-58
  - troubleshooting, 4-39, 4-40
- A37 port 2 step attenuator**
  - illustrated, 6-27, 6-29, 6-35, 6-37, 6-39, 6-41, 6-45, 6-51, 6-53, 6-55, 6-57, 6-59, 6-61, 6-63, 6-65
  - operation, 5-18
  - part number, 6-26, 6-28, 6-34, 6-38, 6-40, 6-42, 6-50, 6-54, 6-58, 6-62
  - removal and replacement
    - illustrated, 7-59
    - procedure, 7-58
  - troubleshooting, 4-39, 4-40
- A38 port 1 bias tee**
  - illustrated, 6-27, 6-29, 6-35, 6-37, 6-39, 6-41, 6-45, 6-51, 6-53, 6-55, 6-57, 6-59, 6-61, 6-63, 6-65
  - operation, 5-18
  - part number, 6-26, 6-28, 6-34, 6-38, 6-40, 6-42, 6-50, 6-54, 6-58, 6-62
  - removal and replacement
    - illustrated, 7-61
    - procedure, 7-60
  - troubleshooting, 4-39, 4-41
- A39 port 2 bias tee**
  - illustrated, 6-27, 6-29, 6-35, 6-37, 6-39, 6-41, 6-45, 6-51, 6-53, 6-55, 6-57, 6-59, 6-61, 6-63, 6-65
  - operation, 5-18
  - part number, 6-26, 6-28, 6-34, 6-38, 6-40, 6-42, 6-50, 6-54, 6-58, 6-62
  - removal and replacement
    - illustrated, 7-61
    - procedure, 7-60
  - troubleshooting, 4-39, 4-41
- A4 power supply assembly**
  - illustrated, 6-15, 6-19
  - operation, 5-33
  - part number, 6-14, 6-18
  - removal and replacement, 7-16
    - illustrated, 7-17
  - troubleshooting, 4-7
- A41 hard disk drive**
  - location of, 6-78, 6-79
  - operation, 5-32
  - removal and replacement
    - illustrated, 7-63
    - procedure, 7-62
- A41 hard disk drive (parallel ATA)**
  - illustrated, 6-81
  - part numbers, 6-80
- A41 hard disk drive (serial ATA)**
  - illustrated, 6-83
  - part numbers, 6-82
- A43 channel A step attenuator**
  - illustrated, 6-39, 6-41
  - operation, 5-18
  - part number, 6-38, 6-40, 6-58, 6-62
  - removal and replacement
    - illustrated, 7-71
    - procedure, 7-70
- A44 channel B step attenuator**
  - illustrated, 6-39, 6-41
  - operation, 5-18
  - part number, 6-38, 6-40, 6-58, 6-62
  - removal and replacement
    - illustrated, 7-71
    - procedure, 7-70
- A45 reference transfer switch**
  - illustrated, 6-47, 6-49, 6-51, 6-53, 6-55, 6-57, 6-59, 6-61, 6-63, 6-65

- operation, 5-24
- part number, 6-46, 6-50, 6-54, 6-58, 6-62
- removal and replacement
  - illustrated, 7-73
  - procedure, 7-72
- troubleshooting, 4-47
- A46 reference transfer switch**
  - illustrated, 6-47, 6-49, 6-51, 6-53, 6-55, 6-57, 6-59, 6-61, 6-63, 6-65
  - operation, 5-24
  - part number, 6-46, 6-50, 6-54, 6-58, 6-62
  - removal and replacement
    - illustrated, 7-73
    - procedure, 7-72
  - troubleshooting, 4-47
- A47 RF path coupler**
  - operation, 5-26
  - removal and replacement
    - illustrated, 7-75
    - procedure, 7-74
- A48 LO path coupler**
  - operation, 5-26
  - removal and replacement
    - illustrated, 7-75
    - procedure, 7-74
- A49 IF multiplexer board**
  - operation, 5-21, 5-26
  - removal and replacement
    - illustrated, 7-55
    - procedure, 7-54
  - troubleshooting, 4-43
- A6 SPAM board**
  - illustrated, 6-15, 6-19
  - operation
    - analog, 5-23
    - digital, 5-31
  - part number, 6-14, 6-18
  - removal and replacement, 7-18
    - illustrated, 7-19
  - troubleshooting, 4-43
- A8 fractional-N synthesizer board**
  - illustrated, 6-15, 6-19
  - operation, 5-8
  - part number, 6-14, 6-18
  - removal and replacement, 7-18
    - illustrated, 7-19
  - troubleshooting
    - band 2, 4-34
    - bands 0 and 1, 4-33
    - bands 3–25, 4-34
- A9 fractional-N synthesizer board**
  - illustrated, 6-19
  - operation, 5-24
  - part number, 6-18
  - removal and replacement, 7-18
    - illustrated, 7-19
  - troubleshooting
    - band 2, 4-45
    - bands 0 and 1, 4-45
    - bands 3–25, 4-46
- accessories**
  - analyzer, 2-7
  - CD-RW drive, 2-7
  - in operator's check, 3-10
  - in test port cable checks, 3-12
  - USB
    - part numbers, 6-86
  - USB hub, 2-7
- accuracy**
  - dynamic accuracy test, 3-37
  - frequency test, 3-32
- adapters**
  - required for servicing, 2-9
- adding**
  - options, 8-16
- adjustments**
  - frequency
    - at 10 MHz, 3-39
    - at 3.8 MHz, 3-40
  - LO offset, 3-43
  - LO power, 3-41
  - phase lock IF gain, 3-46
  - receiver calibration, 3-47
  - source calibration, 3-45
  - system, 3-1, 3-38
    - getting ready, 3-4
- administrator password**
  - Agilent, 7-67
- Agilent**
  - administrator password, 7-67
  - support, 2-11
- airline handling precautions, 3-23**
- analyzer**
  - accessories, 2-7
  - block diagram
    - configurable test set, Option 014, 5-19
    - digital control group, 5-29
    - digital processor group, 5-29
    - frequency offset group, 5-25
    - IF access group, 5-27
    - overall, 4-49
    - receiver group, 5-22
    - signal separation group, 5-17
    - source group, 5-7
  - covers
    - illustrated, 6-77
    - part numbers, 6-76
    - removal and replacement, 7-6
  - external replaceable parts
    - illustrated, 6-77
    - part numbers, 6-76
  - feet
    - illustrated, 6-77
  - part numbers, 6-76
  - frequency range and max output power, 5-4
  - frequency reference board assembly, 5-9
  - front panel interconnects, 5-30
  - functional groups, 5-3
    - digital control, 5-5
    - digital processing, 5-5
    - frequency offset group, 5-4, 5-5
    - power supply, 5-5
    - receiver group, 5-4
    - signal separation, 5-4
    - synthesized source, 5-4
  - internal replaceable parts
    - illustrated, 6-75
    - part numbers, 6-74
  - miscellaneous replaceable parts
    - part numbers, 6-84
  - mounting in equipment rack, 2-5
  - operation
    - A13 frequency offset receiver assembly, 5-24
    - A45 and A46 reference transfer switches, 5-24
    - A47 RF path coupler, 5-26
    - A48 LO path coupler, 5-26
    - A49 IF multiplexer board, 5-26
    - A9 fractional-N synthesizer board, 5-24
    - bias tees, 5-18
    - configurable test set, Option 014, 5-18
    - CPU board, 5-31
    - data acquisition subgroup, 5-31
    - detectors, 5-17
    - digital control group, 5-28
    - digital processor group, 5-28
    - display assembly, 5-30
    - first converters, 5-21
    - fixed attenuators, 5-17
    - fractional-N synthesizer board assembly, 5-8
    - frequency offset group, 5-24
    - front panel interface board, 5-30
    - front panel subgroup, 5-30
    - hard disk drive, 5-32
    - IF access group, 5-26
    - IF multiplexer board, 5-21
    - keypad assembly, 5-30
    - LODA, 5-9
    - main RAM, 5-31
    - mixers, 5-21
    - multiplier/amplifier assembly, 5-9
    - phase lock board assembly, 5-10
    - processing subgroup, 5-31
    - receiver group, 5-21

- receiver modules, 5-21
- receiver motherboard, 5-23
- receiver step attenuators, 5-18
- signal separation group, 5-16
- SOMA 50, 5-11
- source 20 assembly, 5-10
- source group, 5-6
- source step attenuators, 5-18
- SPAM board—analogue, 5-23
- SPAM board—digital, 5-31
- splitter assembly, 5-9
- switch splitter, 5-16
- test port couplers, 5-17
- test set motherboard, 5-12
- USB hub, 5-32
- options, 2-3
- rear panel
  - interconnects, 5-10, 5-12, 5-26, 5-32
- rear panel replaceable parts
  - illustrated, 6-79
  - part numbers, 6-78
- strap handle
  - illustrated, 6-77
  - part number, 6-76
- system, 5-3
- system block diagram, 5-3
- system operation
  - theory of, 5-3
- upgrades, 2-6
- warmup time, 3-4
- ANSI/NCSL Z540-1-1994**
  - verification, 3-8
- ANSI/NCSL Z540-1-1994**
  - non-type verification, 3-9
- assemblies**
  - location of part numbers, 6-8
  - rebuilt-exchange
    - procedure, 6-5
  - rebuilt-exchange program, 6-5
  - replacement
    - cautions about, 7-3
    - list of procedures, 7-4
    - sequence, 6-4, 7-3
    - warnings about, 7-3
- attenuator bracket**
  - illustrated, 6-71, 6-73
  - part number, 6-70, 6-72
- attenuators**
  - receiver
    - operation, 5-18
  - required for servicing, 2-9
  - source
    - operation, 5-18
  - step, 60-dB receiver
    - illustrated, 6-27, 6-29, 6-35, 6-37, 6-39, 6-41, 6-45, 6-51, 6-53, 6-55, 6-57, 6-59, 6-61, 6-63, 6-65
    - part number, 6-26, 6-28, 6-34, 6-38, 6-40, 6-42, 6-50, 6-54, 6-58, 6-62
- attenuators, 30-dB**
  - removal and replacement procedure, 7-46
- attenuators, fixed, 30-dB**
  - illustrated, 6-23
  - part number, 6-22
  - removal and replacement
    - illustrated, 7-47
    - procedure, 7-46
- AUX I/O connector**
  - pin assignments, 5-15
  - rear panel, 5-12
- B**
- B channel**
  - attenuator
    - removal and replacement, 7-70
  - troubleshooting, 4-26
  - typical power output, 4-39
- B receiver module**
  - troubleshooting, 4-43
- B trace**
  - troubleshooting, 4-26, 4-29
- B1 fan**
  - removal and replacement, 7-76
- band failure, all, 4-28**
- band modes**
  - source group
    - configurations, 5-6
    - operation, 5-6
  - troubleshooting
    - any band for A12, 4-46
    - band 2, 4-34, 4-45
    - bands 0 and 1, 4-33
    - bands 0 and 1 for A9, 4-45
    - bands 3–25, 4-34
    - bands 3–25 for A9, 4-46
- band related failure, 4-28**
- battery**
  - cpu battery disposal, 1-9
  - removal and replacement
    - illustrated, 7-81
    - procedure, 7-80
- battery disposal, 1-9**
- before applying power, 1-3**
- bias tee**
  - port 1
    - illustrated, 6-27, 6-29, 6-35, 6-37, 6-39, 6-41, 6-45, 6-51, 6-53, 6-55, 6-57, 6-59, 6-61, 6-63, 6-65
    - part number, 6-26, 6-28, 6-34, 6-38, 6-40, 6-42, 6-50, 6-54, 6-58, 6-62
  - port 2
    - illustrated, 6-27, 6-29, 6-35, 6-37, 6-39, 6-41, 6-45, 6-51, 6-53, 6-55, 6-57, 6-59, 6-61, 6-63, 6-65
    - part number, 6-26, 6-28, 6-34, 6-38, 6-40, 6-42, 6-50, 6-54, 6-58, 6-62
- bias tee bracket**
  - illustrated, 6-71, 6-73
  - part number, 6-70, 6-72
- bias tee, port 1**
  - operation, 5-18
  - removal and replacement
    - illustrated, 7-61
    - procedure, 7-60
  - troubleshooting, 4-41
- bias tee, port 2**
  - operation, 5-18
  - removal and replacement
    - illustrated, 7-61
    - procedure, 7-60
  - troubleshooting, 4-41
- block diagram**
  - configurable test set, 5-19
  - digital control group, 5-29
  - digital processor group, 5-29
  - frequency offset group, 5-25
  - IF access group, 5-27
  - receiver group, 5-22
  - signal separation group, 5-17
  - source group, 5-7
- block diagrams**
  - overall instrument, 4-49
- bottom assembly**
  - replaceable cables, flexible
    - illustrated, 6-67
    - part numbers, 6-66
  - replaceable cables, ribbon
    - illustrated, 6-69
    - part numbers, 6-68
  - replaceable cables, wrapped
    - illustrated, 6-69
    - part numbers, 6-68
- bottom assembly, hardware**
  - illustrated, 6-71, 6-73
  - part numbers, 6-70, 6-72
- bottom assembly, no hardware options**
  - replaceable parts
    - illustrated, 6-23
    - part numbers, 6-22

**bottom assembly, no options**  
replaceable cables, semi-rigid  
illustrated, 6-25  
part numbers, 6-24

**bottom assembly, Option 014**  
replaceable cables  
illustrated, 6-31, 6-33  
part numbers, 6-30, 6-32

**bottom assembly, Option 014/080/081**  
replaceable cables  
illustrated, 6-47, 6-49  
part numbers, 6-46, 6-48  
replaceable parts  
illustrated, 6-47, 6-49  
part numbers, 6-46

**bottom assembly, Option UNL**  
replaceable parts  
illustrated, 6-27, 6-29  
part numbers, 6-26, 6-28

**bottom assembly, Option UNL/014**  
replaceable cables  
illustrated, 6-35, 6-37  
part numbers, 6-34, 6-36  
replaceable parts  
illustrated, 6-35, 6-37  
part numbers, 6-34

**bottom assembly, Option UNL/014/016**  
replaceable cables  
illustrated, 6-45  
part numbers, 6-42, 6-44  
replaceable parts  
illustrated, 6-45  
part numbers, 6-42

**bottom assembly, Option UNL/014/016/080/081**  
replaceable cables  
illustrated, 6-59, 6-61, 6-63, 6-65  
part numbers, 6-58, 6-60, 6-62, 6-64  
replaceable parts  
illustrated, 6-59, 6-61, 6-63, 6-65

**bottom assembly, Option UNL/014/0160/80/081**  
replaceable parts  
part numbers, 6-58, 6-62

**bottom assembly, Option UNL/014/080/081**  
replaceable cables  
illustrated, 6-51, 6-53, 6-55, 6-57  
part numbers, 6-50, 6-52, 6-54, 6-56  
replaceable parts  
illustrated, 6-51, 6-53, 6-55, 6-57  
part numbers, 6-50, 6-54

**bottom assembly, Option UNL/016**  
replaceable cables  
illustrated, 6-39, 6-41  
part numbers, 6-38, 6-40  
replaceable parts  
illustrated, 6-39, 6-41  
part numbers, 6-38, 6-40

**bracket**  
attenuator  
illustrated, 6-71, 6-73  
part number, 6-70, 6-72  
bias tee  
illustrated, 6-71, 6-73  
part number, 6-70, 6-72  
detector  
illustrated, 6-71, 6-73  
part number, 6-70, 6-72  
**broadband failure**, 4-28, 4-31

**built-in tests**  
for commercial calibration, Option 897,  
2-6  
for standards compliant calibration,  
Option 898, 2-6

## C

**cable**  
substitution, 3-22  
test port  
checks, 3-10, 3-12, 3-13, 3-14, 3-15,  
3-17  
connector repeatability failure, 3-18  
insertion loss failure, 3-14  
magnitude and phase stability  
failure, 3-16  
return loss failure, 3-13

**cables**  
GPIB  
part numbers, 6-84  
in bottom assembly, no options  
illustrated, 6-25  
in bottom assembly, Option 014  
illustrated, 6-31, 6-33  
part numbers, 6-30, 6-32  
in bottom assembly,  
Option 014/080/081  
illustrated, 6-47, 6-49  
part numbers, 6-46, 6-48  
in bottom assembly, Option UNL/014  
illustrated, 6-35, 6-37  
part numbers, 6-34, 6-36  
in bottom assembly,  
Option UNL/014/016  
illustrated, 6-45  
part numbers, 6-42, 6-44  
in bottom assembly,  
Option UNL/014/016/080/081  
illustrated, 6-59, 6-61, 6-63, 6-65  
part numbers, 6-58, 6-60, 6-62, 6-64  
in bottom assembly,  
Option UNL/014/080/081  
illustrated, 6-51, 6-53, 6-55, 6-57  
part numbers, 6-50, 6-52, 6-54, 6-56  
in bottom assembly,  
Option UNL/014/081  
part numbers, 6-52, 6-54, 6-56

part numbers, 6-52, 6-56  
in bottom assembly, Option UNL/016  
illustrated, 6-39, 6-41  
part numbers, 6-38, 6-40  
in top assembly, Option 080  
illustrated, 6-21  
part numbers, 6-20  
in top assembly, without Option 080  
part numbers, 6-16  
in top assembly, without Option 080  
illustrated, 6-17  
location of part numbers, 6-8  
required for servicing, 2-9

**cables, flexible**  
in bottom assembly  
illustrated, 6-67  
part numbers, 6-66

**cables, ribbon**  
in bottom assembly  
illustrated, 6-69  
part numbers, 6-68

**cables, semi-rigid**  
in bottom assembly  
part numbers, 6-24

**cables, wrapped**  
in bottom assembly  
illustrated, 6-69  
part numbers, 6-68

**calibration**  
certificate of, 3-7  
coefficients test, 3-35  
commercial, built-in tests, Option 897,  
2-6  
kits, 2-9, 3-7  
substitution, 3-22  
measurement, 8-4  
receiver, 3-47  
source, 3-45  
standards compliant, built-in tests,  
Option 898, 2-6

**care of connectors**, 3-5

**caution**, 1-3

**CD-RW drive**, 2-7

**CE mark**, 1-8

**certificate of calibration**, 3-7

**changing**  
a serial number, 8-18

**channel A**  
troubleshooting, 4-26, 4-38  
typical power output, 4-38

**channel A receiver module**  
troubleshooting, 4-43

**channel B**  
troubleshooting, 4-26, 4-38  
typical power output, 4-39

**channel B receiver module**  
troubleshooting, 4-43

**channel R1**  
troubleshooting, 4-26

## channel R1 receiver module

troubleshooting, 4-43

## channel R2

troubleshooting, 4-26

## channel R2 receiver module

troubleshooting, 4-43

## checks

### cable

connector repeatability, failure of, 3-18

insertion loss, failure of, 3-14  
magnitude and phase stability, failure of, 3-16

return loss, failure of, 3-13  
test port cables, 3-10, 3-12

operator's, 3-10

accessories used in, 3-10

dialog box, 3-11

failure of, 3-11

performing, 3-10

Port 1, 3-10

Port 2, 3-10

preliminary, 3-10

system, 3-1

getting ready, 3-4

test port cable

accessories used in, 3-12

connector repeatability, 3-17

insertion loss, 3-14

magnitude and phase stability, 3-15

performing, 3-12

return loss, 3-13

## COM, 8-9

### commercial calibration

built-in tests, Option 897, 2-6

compression test, receiver, 3-33

configurable test set, Option 014, 2-3

block diagram, 5-19

operation, 5-18

### configuration

high dynamic range, 5-20

diagram, 5-20

Option 014, 5-19

### connector

#### care

principles of, 3-5

quick reference, 3-5

protective end caps

part numbers, 6-84

repeatability check

failure of, 3-18

of test port cables, 3-17

#### connector repeatability

check

test port cables, 3-17

### connectors

care of, 3-5

front panel, 5-30

USB, 5-30

rear panel, 5-10, 5-12, 5-32

1284-C, 5-32

8.33 MHz IF IN, 5-26

AUX I/O, 5-12, 5-15

Display, 5-32

EXT 10 MHz REF IN, 5-10

EXT 10 MHz REF OUT, 5-10

GPIB, 5-32

HANDLER I/O, 5-12, 5-14

PARALLEL, 5-32

PULSE IN, 5-26

RS-232, 5-32

SERIAL, 5-32

TEST SET DRIVERS, 5-26

TEST SET I/O, 5-12, 5-13

TRIG IN, 5-12

TRIG OUT, 5-12

USB, 5-32

VGA, 5-32

### constants

correction, 8-21

### controller board, touch screen

removal and replacement

illustrated, 7-13

procedure, 7-12

### controllers

troubleshooting with, 4-19

correction constants, 8-21

### coupler

LO path

operation, 5-26

nut

illustrated, 6-71, 6-73

part number, 6-70, 6-72

port 1

illustrated, 6-23

part number, 6-22

troubleshooting, 4-40

port 2

illustrated, 6-23

part number, 6-22

troubleshooting, 4-40

RF path

operation, 5-26

### coupler, LO path

removal and replacement

illustrated, 7-75

procedure, 7-74

### coupler, RF path

removal and replacement

illustrated, 7-75

procedure, 7-74

### cover, removing, 1-4

### covers, analyzer

illustrated, 6-77

part numbers, 6-76

removal and replacement

illustrated, 7-7

procedure, 7-6

### CPU board

illustrated, 6-15, 6-19

operation, 5-31

part number, 6-14, 6-18

removal and replacement

illustrated, 7-30

procedure, 7-28

troubleshooting, 4-17

### cross talk

system test, 3-36

test port test, 3-36

cross-over cable, LAN, 4-22

CSA mark, 1-8

## D

dangerous voltage, 1-4

### data acquisition

operation, 5-31

### data acquisition and processing

subgroup, 5-28

### data storage

hard disk, 5-32

IDE, 5-32

### data, option

recovering, 8-17

repairing, 8-17

### DCOM, 8-9

### description

functional

digital control group, 5-5

digital processing group, 5-5

frequency offset group, 5-4, 5-5

power supply group, 5-5

receiver group, 5-4

signal separation group, 5-4

synthesized source group, 5-4

### detector

channel R1

illustrated, 6-23

operation, 5-17

part number, 6-22

removal and replacement illustrated, 7-49

removal and replacement procedure, 7-48

channel R1, Option 014/080/081

illustrated, 6-47, 6-49

channel R1, Option 081

part number, 6-46

channel R2

illustrated, 6-23

operation, 5-17

part number, 6-22

removal and replacement illustrated, 7-49

removal and replacement procedure, 7-48



**detector bracket**  
illustrated, 6-71, 6-73  
part number, 6-70, 6-72

**device connections**  
system verification, 3-25

**digital control group**  
block diagram, 5-29  
functional description of, 5-5  
operation, 5-28

**digital processing and control**  
functional group, 5-3

**digital processing group**  
block diagram, 5-29  
functional description of, 5-5  
operation, 5-28

**directivity**  
cause of failure, 8-12  
definition of, 8-12  
measurements affected by, 8-12

**disabling**  
options, 8-16

**display assembly**  
illustrated, 6-13  
operation, 5-30  
parts list, 6-12  
removal and replacement  
illustrated, 7-13  
procedure, 7-13  
troubleshooting, 4-12

**display assembly, touch screen**  
removal and replacement  
illustrated, 7-13, 7-15  
procedure, 7-15

**Display port**  
rear panel connector, 5-32

**display test**  
running, 4-15

**documentation**  
part numbers, 6-84  
printing copies, -iv  
standard, -iv

**dynamic range, high configuration, 5-20**

**E**

**earth ground, 1-3**

**electrostatic discharge, See ESD**

**EMI/RFI**  
supplies  
part numbers, 6-86

**enabling**  
options, 8-16

**entitlement certificate, option, 8-15**

**environment, operating**  
specifications, 3-4  
verification, 3-4

**equipment rack**  
horizontal spacing, 2-5  
mounting analyzer in, 2-5

**equipment, service test**  
required, 2-8

**error term data**  
description of, 8-10

**error terms**  
access to, 8-8  
via COM/DCOM commands, 8-9  
via front panel, 8-8  
via SCPI commands (using GPIB), 8-9  
cause of failure to, 8-3  
descriptions, 8-10  
directivity, 8-12  
flowgraph of one port, 8-4  
flowgraph of two port, 8-5, 8-6, 8-7  
identifying using flowgraphs, 8-4  
isolation, 8-14  
load match, 8-12  
magnitude  
affected by, 8-3  
monitoring over time, 8-3  
reflection tracking, 8-13  
shape affected by, 8-3  
source match, 8-12  
transmission tracking, 8-13  
typical data, 8-10  
using as diagnostic tool, 8-3  
using to aid troubleshooting, 8-3  
worse than typical values, 8-11

**ESD**  
protection, 1-6, 3-4, 4-3, 7-3, 8-4  
supplies  
part numbers, 6-86

**exchange**  
module  
procedure, 6-5  
rebuilt assemblies  
program, 6-5

**EXT 10 MHz REF IN connector**  
rear panel, 5-10

**EXT 10 MHz REF OUT connector**  
rear panel, 5-10

**extender board**  
measurement points, 4-8  
voltages, 4-8

**external analyzer**  
replaceable parts  
illustrated, 6-77  
part numbers, 6-76

## F

**failure**  
all bands, 4-28  
band related, 4-28  
broadband, 4-28, 4-31  
of connector repeatability check, 3-18  
of insertion loss check, 3-14

of magnitude and phase stability  
check, 3-16  
of operator's check, 3-11  
of return loss check, 3-13  
of system verification, 3-26  
flowchart, 3-26  
single vs. broadband, 4-31

## fan

removal and replacement, 7-76  
troubleshooting, 4-11

## feet

analyzer  
illustrated, 6-77  
part numbers, 6-76

## firmware upgrade

downloading from the internet, 8-19  
Option 099, 2-5

## first converter

channel A  
illustrated, 6-23  
part number, 6-22  
removal and replacement  
illustrated, 7-53  
removal and replacement illustrated,  
7-53  
removal and replacement procedure,  
7-52  
troubleshooting, 4-42

## channel B

illustrated, 6-23  
part number, 6-22  
removal and replacement illustrated,  
7-53  
removal and replacement procedure,  
7-52  
troubleshooting, 4-42

## channel R1

illustrated, 6-23  
part number, 6-22  
removal and replacement illustrated,  
7-53  
removal and replacement procedure,  
7-52  
troubleshooting, 4-42

## channel R2

illustrated, 6-23  
part number, 6-22  
removal and replacement illustrated,  
7-53  
removal and replacement procedure,  
7-52  
troubleshooting, 4-42

## fixed attenuator

channel R1  
illustrated, 6-23  
operation, 5-17  
part number, 6-22

- channel R2
    - illustrated, 6-23
    - operation, 5-17
    - part number, 6-22
  - flowgraph**
    - of one port error terms, 8-4
    - of two port error terms, 8-5, 8-6, 8-7
    - using to identify error terms, 8-4
  - Fourier transform**, 2-3
  - fractional-N synthesizer board**
    - illustrated, 6-15, 6-19
    - operation, 5-8
    - operation, A9, 5-24
    - part number, 6-14, 6-18
    - removal and replacement
      - illustrated, 7-19
      - procedure, 7-18
    - troubleshooting
      - band 2, 4-34
      - band 2 for A9, 4-45
      - bands 0 and 1, 4-33
      - bands 0 and 1 for A9, 4-45
      - bands 3–25, 4-34
  - frequency accuracy**
    - test, 3-32
  - frequency adjustment**
    - at 10 MHz, 3-39
    - at 3.8 MHz, 3-40
  - frequency offset**
    - functional description of, 5-4, 5-5
  - frequency offset group**
    - block diagram, 5-25
    - defined, 4-28
    - operation, 5-24
    - troubleshooting, 4-44
  - frequency offset mode**
    - Option 080, 2-4
  - frequency offset receiver**
    - illustrated, 6-19
    - part number, 6-18
    - removal and replacement
      - illustrated, 7-25
      - procedure, 7-24
    - troubleshooting, 4-47
  - frequency range**
    - and max output power, 5-4
  - frequency reference board**
    - illustrated, 6-15, 6-19
    - operation, 5-9
    - part number, 6-14, 6-18
    - removal and replacement
      - illustrated, 7-19
      - procedure, 7-18
    - troubleshooting, 4-32, 4-33, 4-44
  - frequency upgrade to 40 GHz**
    - Option 040, 2-4
  - frequency upgrade to 50 GHz**
    - Option 050, 2-4
  - frequency upgrade to 67 GHz**
    - Option 067, 2-4
  - front panel**
    - connectors
      - USB, 5-30
    - interconnects, 5-30
    - knob
      - illustrated, 6-11
      - part number, 6-10
      - test, 4-15
      - troubleshooting, 4-12
    - LED board
      - illustrated, 6-71, 6-73
      - part number, 6-70, 6-72
    - name plate
      - illustrated, 6-11
      - part number, 6-10
    - operation, 5-30
    - overlays
      - illustrated, 6-11
      - part numbers, 6-10
    - speaker, 5-30
    - subgroup, 5-28
    - troubleshooting, 4-12
    - USB
      - troubleshooting, 4-17
  - front panel assembly**
    - removal and replacement
      - illustrated, 7-11
      - procedure, 7-10
    - replaceable parts
      - illustrated, 6-11, 6-13
      - part numbers, 6-10, 6-12
  - front panel interface board**
    - illustrated, 6-13
    - operation, 5-30
    - part number, 6-12
    - removal and replacement
      - illustrated, 7-13
      - procedure, 7-14
    - troubleshooting, 4-12
  - front panel keypad assembly**
    - troubleshooting, 4-12
  - front panel subassemblies**
    - removal and replacement
      - illustrated, 7-13
      - procedures, 7-12
  - front-panel jumpers, Option 014**
    - illustrated, 6-31, 6-33
    - part number, 6-30, 6-32
  - functional groups**, 5-3
  - fuses**
    - part number, 6-86
- ## G
- general safety considerations**, 1-3
  - GPIO**, 8-9
    - cables
      - part numbers, 6-84
    - port
      - rear panel connector, 5-32
      - running test software, 4-18
      - troubleshooting, 4-18
      - systems check, 4-18
  - ground, safety earth**, 1-3
  - groups**
    - functional, 5-3
- ## H
- handle**
    - damaged, 1-3
    - kits
      - part numbers, 6-86
  - HANDLER I/O**
    - connector
      - pin assignments, 5-14
      - rear panel, 5-12
  - handles**
    - with rack mount, 2-5
  - handling airlines**
    - precautions, 3-23
  - hard disk drive**
    - copying files from, 7-62
    - data storage, 5-32
    - installing backup files onto, 7-67
    - location of, 6-78, 6-79
    - operation, 5-32
    - removal and replacement
      - illustrated, 7-63
      - procedure, 7-62
    - replaceable parts
      - illustrated, 6-83
    - unique files located on, 7-62
  - hard disk drive (parallel ATA)**
    - illustrated, 6-81
    - part number, 6-80
    - replaceable parts
      - illustrated, 6-81
      - part numbers, 6-80
  - hard disk drive (serial ATA)**
    - illustrated, 6-83
    - part number, 6-82
    - replaceable parts
      - part numbers, 6-82
  - hardware**
    - for bottom assemblies
      - illustrated, 6-71, 6-73
      - part numbers, 6-70, 6-72
    - for top assemblies, Option 080
      - illustrated, 6-19
      - part numbers, 6-18
    - for top assemblies, without Option 080
      - part numbers, 6-14, 6-15
    - in hard disk drive (parallel ATA)
      - part numbers, 6-80

- in hard disk drive (parallel ATA)
    - assembly
    - illustrated, 6-81
  - in hard disk drive (serial ATA)
    - part numbers, 6-82
  - in hard disk drive (serial ATA)
    - assembly
    - illustrated, 6-83
  - in internal analyzer
    - illustrated, 6-75
    - part numbers, 6-74
  - in rear panel assembly
    - illustrated, 6-79
    - part numbers, 6-78
  - location of part numbers, 6-9
  - options, 8-16
  - high dynamic range**
    - configuration, 5-20
    - diagram, 5-20
  - hub, USB**
    - removal and replacement
      - illustrated, 7-79
      - procedure, 7-79
- I**
- IDE**
    - data storage, 5-32
  - IF access group**
    - block diagram, 5-27
    - operation, 5-26
  - IF access, Option H11**
    - operation verification, 3-29
  - IF access, Option H11, 2-6**
  - IF gain**
    - adjustment for phase lock, 3-46
  - IF IN connectors**
    - operation, 5-26
  - IF multiplexer board**
    - operation, 5-21, 5-26
    - removal and replacement
      - illustrated, 7-55
      - procedure, 7-54
    - troubleshooting, 4-43
  - insertion loss**
    - check
      - failure of, 3-14
      - test port cables, 3-14
  - installing**
    - a serial number, 8-18
  - instruction documentation symbol, 1-8**
  - instrument block diagrams**
    - overall, 4-49
  - instrument markings, 1-8**
  - instrument specifications, 3-6**
  - interconnects**
    - AUX I/O
      - pin assignments, 5-15
    - front panel, 5-30
    - USB, 5-30
  - HANDLER I/O**
    - pin assignments, 5-14
  - rear panel, 5-10, 5-12, 5-32
    - 1284-C, 5-32
    - AUX I/O, 5-12
    - Display, 5-32
    - EXT 10 MHz REF IN, 5-10
    - EXT 10 MHz REF OUT, 5-10
    - GPIB, 5-32
    - HANDLER I/O, 5-12
    - LAN, 5-32
    - PARALLEL, 5-32
    - RS-232, 5-32
    - SERIAL, 5-32
    - TEST SET I/O, 5-12
    - TRIG IN, 5-12
    - TRIG OUT, 5-12
    - USB, 5-32
    - VGA, 5-32
  - TEST SET I/O
    - pin assignments, 5-13
  - internal analyzer**
    - replaceable hardware
      - illustrated, 6-75
    - replaceable parts
      - illustrated, 6-75
      - part numbers, 6-74
  - inverter board**
    - removal and replacement
      - illustrated, 7-13
      - procedure, 7-12
  - IP address, LAN, 4-20**
  - ISM1-A mark, 1-8**
  - isolation**
    - cause of failure, 8-14
    - definition of, 8-14
    - measurements affected by, 8-14
- J**
- jumpers, front-panel**
    - Option 014
      - illustrated, 6-31, 6-33
      - part number, 6-30, 6-32
- K**
- keypad assembly**
    - illustrated, 6-13
    - operation, 5-30
    - part number, 6-12
    - removal and replacement
      - illustrated, 7-13
      - procedure, 7-14
    - test, 4-14
    - troubleshooting, 4-12
  - kits**
    - calibration, 2-9, 3-7
    - handle
      - part numbers, 6-86
    - rack mount
      - part numbers, 6-86
    - upgrade
      - part numbers, 6-85
    - verification, 2-9, 3-7
  - knob**
    - front panel
      - illustrated, 6-11
      - part number, 6-10
    - test, 4-15
    - troubleshooting, 4-12
- L**
- LAN**
    - connector
      - rear panel, 5-32
    - cross-over cable, 4-22
    - IP address, 4-20
    - ping command, 4-20
    - ping to and from, 4-20
    - subnet mask, 4-20
    - testing between analyzers, 4-22
    - troubleshooting, 4-20
  - LED board, front panel**
    - illustrated, 6-71, 6-73
    - part number, 6-70, 6-72
  - linearity**
    - source power
      - test, 3-31
    - test port output power
      - test, 3-31
  - lithium battery**
    - removal and replacement, 7-80
    - illustrated, 7-81
  - lithium battery disposal, 1-9**
  - LO offset**
    - adjustment, 3-43
  - LO path coupler**
    - removal and replacement
      - illustrated, 7-75
      - procedure, 7-74
  - LO path coupler, A48**
    - operation, 5-26
  - load match**
    - cause of failure, 8-12
    - definition of, 8-12
    - measurements affected by, 8-12, 8-13
  - locating**
    - assembly part numbers, 6-8
    - cable part numbers, 6-8
    - hardware part numbers, 6-9
    - miscellaneous part numbers, 6-9
    - part numbers
      - by type of part, 6-8

- replaceable parts
  - by reference designator, 6-6
- LODA**
  - illustrated, 6-23
  - operation, 5-9
  - part number, 6-22
  - removal and replacement
    - illustrated, 7-41
    - procedure, 7-40
  - troubleshooting, 4-37
- LOMA 10**
  - illustrated, 6-23
  - operation, 5-9
  - part number, 6-22
  - removal and replacement
    - illustrated, 7-35
    - procedure, 7-34
  - troubleshooting, 4-34
- M**
- MA 20**
  - illustrated, 6-23
  - operation, 5-9
  - part number, 6-22
  - removal and replacement
    - illustrated, 7-37
    - procedure, 7-36
  - troubleshooting, 4-37
- machine screws**
  - for bottom assemblies
    - illustrated, 6-71, 6-73
    - part numbers, 6-70, 6-72
- magnitude check**
  - failure of, 3-16
  - test port cables, 3-15
- maintenance**
  - cleaning, 2-3
  - preventive
    - effect on error terms, 8-3
- manuals, printing copies, -iv**
- max output power**
  - and frequency range, 5-4
- measurement**
  - calibration, 8-4
  - traceability, 3-21
    - path, 3-21
    - uncertainty, 3-20
- measurement system**
  - troubleshooting, 4-24
- measuring**
  - high-dynamic range devices, 2-3
  - high-power devices, 2-3
- midweb**
  - removal and replacement, 7-76
  - illustrated, 7-77
- midweb fans**
  - troubleshooting, 4-11
- miscellaneous parts**
  - location of part numbers, 6-9
- miscellaneous replaceable parts**
  - part numbers, 6-84
- mixer bias board**
  - illustrated, 6-71, 6-73
  - part number, 6-70, 6-72
- mixer bracket**
  - illustrated, 6-71, 6-73
  - part number, 6-70, 6-72
- module**
  - exchange
    - procedure, 6-5
- motherboard, receiver**
  - illustrated, 6-23
  - part number, 6-22
- motherboard, system**
  - illustrated, 6-15, 6-19
  - operation, 5-30
  - part number, 6-14, 6-18
  - removal and replacement
    - illustrated, 7-27
    - procedure, 7-26
  - troubleshooting, 4-11
- motherboard, test set**
  - illustrated, 6-23
  - part number, 6-22
- multiplier/amplifier assembly**
  - operation, 5-9
- N**
- N7840A software**
  - tests, 3-30
- name plate**
  - front panel
    - illustrated, 6-11
    - part number, 6-10
- network analyzer. *See analyzer***
- noise floor, test, 3-34**
- noise, trace noise test, 3-32**
- Non-ANSI/NCSL Z540-1-1994**
  - verification, 3-9
- nut**
  - test port coupler
    - illustrated, 6-71, 6-73
    - part number, 6-70, 6-72
- O**
- OCXO (oven-controlled crystal oscillator)**
  - frequency adjustment, 3-39
  - theory of operation, 5-9
- offset receiver**
  - troubleshooting, 4-47
- operating environment**
  - specifications, 3-4
  - verification, 3-4
- operating system**
  - recovery, 8-20
- operation**
  - bias tees, 5-18
  - configurable test set, Option 014, 5-18
  - CPU board, 5-31
  - data acquisition, 5-31
  - detectors, 5-17
  - digital control, 5-28
  - digital processor, 5-28
  - display assembly, 5-30
  - first converters, 5-21
  - fixed attenuators, 5-17
  - fractional-N synthesizer, 5-8
  - fractional-N synthesizer board, 5-24
  - frequency offset group, 5-24
  - frequency offset receiver, 5-24
  - frequency reference board, 5-9
  - front panel, 5-30
  - front panel interface board, 5-30
  - hard disk drive, 5-32
  - IF access group, 5-26
  - IF multiplexer board, 5-21, 5-26
  - keypad assembly, 5-30
  - LO path coupler, 5-26
  - LODA, 5-9
  - LOMA 10, 5-9
  - MA 20, 5-9
  - main RAM, 5-31
  - phase lock board, 5-10
  - power supply, 5-33
  - processing subgroup, 5-31
  - receiver group, 5-21
  - receiver mixers, 5-21
  - receiver modules, 5-21
  - receiver motherboard, 5-23
  - reference transfer switches, 5-24
  - RF path coupler, 5-26
  - signal separation group, 5-16
  - SOMA 50, 5-11
  - source, 5-6
  - source assembly, 5-10
  - source group, band modes, 5-6
  - SPAM board—analogue, 5-23
  - SPAM board—digital, 5-31
  - splitter assembly, 5-9
  - step attenuators
    - receiver, 5-18
    - source, 5-18
  - switch splitter (A22), 5-16
  - system motherboard, 5-30
  - test port couplers, 5-17
  - test set motherboard, 5-12
  - USB hub, 5-32
- operator's check, 3-10**
  - accessories used in, 3-10
  - dialog box, 3-11
  - failure of, 3-11
  - performing, 3-10
  - Port 1, 3-10

- Port 2, 3-10
  - option**
    - data
      - recovering, 8-17
      - repairing, 8-17
    - enable utility
      - accessing, 8-15
      - dialog box, 8-15
    - enabling and removing, 8-16
    - entitlement certificate, 8-15
    - hardware, 8-16
    - service and support, 2-11
    - software, 8-16
  - Option 010, time domain**, 2-3
  - Option 014, configurable test set**, 2-3
    - block diagram, 5-19
    - normal configuration, 5-19
    - operation, 5-18
  - Option 016**
    - receiver attenuators, 5-18
  - Option 016, receiver attenuators**, 2-4
  - Option 040, extended frequency to 40 GHz**, 2-4
  - Option 050, extended frequency to 50 GHz**, 2-4
  - Option 067, extended frequency to 67 GHz**, 2-4
  - Option 080, frequency offset mode**, 2-4
  - Option 081, transfer switch**, 2-5
  - Option 099, firmware upgrade**, 2-5
  - Option 1CM, rack mount without handles**, 2-5
  - Option 1CP, rack mount with handles**, 2-5
  - Option 897**
    - built-in tests for commercial calibration, 2-6
  - Option 898**
    - built-in tests for standard compliant calibration, 2-6
  - Option H08, pulse measurement capability**, 2-6
  - Option H11**
    - IF access
      - operation, 5-26
  - Option H11, IF access**, 2-6
    - operation verification, 3-29
  - Option UNL, 60-dB source step attenuators**, 5-18
  - Option UNL, replaceable parts**
    - illustrated, 6-27, 6-29
    - part numbers, 6-26, 6-28
  - Option UNL, source attenuator**, 2-6
  - Option UNL/014**
    - replaceable parts
      - illustrated, 6-35, 6-37
      - part numbers, 6-34
  - Option UNL/014/016**
    - replaceable parts
      - illustrated, 6-45
      - part numbers, 6-42
  - Option UNL/014/016/080/081**
    - replaceable parts
      - illustrated, 6-59, 6-61, 6-63, 6-65
      - part numbers, 6-58, 6-62
  - Option UNL/014/080/081**
    - replaceable parts
      - illustrated, 6-51, 6-53, 6-55, 6-57
      - part numbers, 6-50, 6-54
  - Option UNL/016**
    - replaceable parts
      - illustrated, 6-39, 6-41
      - part numbers, 6-38, 6-40
  - options**
    - analyzer, 2-3
  - ordering information**
    - options and upgrades, 2-3, 2-6
    - replaceable parts, 6-3
  - output power, source**
    - accuracy test, 3-30
    - linearity, 3-31
    - maximum test, 3-31
  - output power, test port**
    - accuracy test, 3-30
    - linearity, 3-31
    - maximum test, 3-31
  - overlays**
    - front panel
      - illustrated, 6-11
      - part numbers, 6-10
- P**
- pad**
    - 30-dB
      - illustrated, 6-23
      - part number, 6-22
  - pads**
    - required for servicing, 2-9
  - paint**
    - touch-up
      - part numbers, 6-86
  - PARALLEL**
    - port
      - troubleshooting, 4-18
  - PARALLEL port**
    - rear panel connector, 5-32
  - part numbers**
    - accessories
      - USB, 6-86
    - cables
      - for bottom assembly, Option 014, 6-30, 6-32
      - for bottom assembly, Option 014/080/081, 6-46, 6-48
      - for bottom assembly, Option UNL/014, 6-34, 6-36
      - for bottom assembly, Option UNL/014/016, 6-42, 6-44
  - for bottom assembly,
    - Option UNL/014/016/080/081, 6-58, 6-60, 6-62, 6-64
  - for bottom assembly,
    - Option UNL/014/080/081, 6-50, 6-52, 6-54, 6-56
  - for bottom assembly,
    - Option UNL/016, 6-38, 6-40
  - for top assembly, Option 080, 6-20
  - for top assembly, without Option 080, 6-16
  - GPIB, 6-84
- cables, flexible
  - for bottom assembly, 6-66
- cables, ribbon
  - for bottom assembly, 6-68
- cables, semi-rigid
  - for bottom assembly, no options, 6-24
- cables, wrapped
  - for bottom assembly, 6-68
- documentation, 6-84
- hardware
  - in hard disk drive (parallel ATA), 6-80
  - in hard disk drive (serial ATA), 6-82
  - in internal analyzer, 6-74
  - in rear panel assembly, 6-78
- kits
  - handle, 6-86
  - rack mount, 6-86
- locating
  - by reference designator, 6-6
  - for assemblies, 6-8
  - for cables, 6-8
  - for hardware, 6-9
  - for miscellaneous parts, 6-9
- locating by type of part, 6-8
- paint
  - touch-up, 6-86
- protective end caps
  - for connectors, 6-84
- replaceable parts
  - analyzer covers, 6-76
  - analyzer feet, 6-76
  - analyzer strap handle, 6-76
  - external analyzer, 6-76
  - for bottom assembly, Option UNL, 6-26, 6-28
  - for bottom assembly, Option UNL/014, 6-34
  - for bottom assembly, Option UNL/014/016, 6-42
  - for bottom assembly, Option UNL/014/016/080/081, 6-58, 6-62
  - for bottom assembly, Option UNL/014/080/081, 6-50, 6-54

- for bottom assembly,
    - Option UNL/016, 6-38, 6-40
  - for top assembly, Option 080, 6-18
  - for top assembly, without
    - Option 080, 6-14
  - in bottom assembly, 6-22
  - in bottom assembly,
    - Option 014/080/081, 6-46
  - in front panel assembly, 6-10, 6-12
  - in hard disk drive (parallel ATA), 6-80
  - in hard disk drive (serial ATA), 6-82
  - in internal analyzer, 6-74
  - in rear panel assembly, 6-78
  - miscellaneous analyzer, 6-84
  - replaceable parts, hardware
    - for bottom assembly, 6-70, 6-72
  - supplies
    - EMI/RFI, 6-86
    - ESD, 6-86
  - tools
    - service, 6-84
  - upgrade kits, 6-85
  - upgrade kits for E8362C, 6-85
  - upgrade kits for E8363C, 6-85
  - upgrade kits for E8364C, 6-85
- parts**
- external analyzer
    - illustrated, 6-77
    - part numbers, 6-76
  - in bottom assembly, no hardware
    - options
      - illustrated, 6-23
      - part numbers, 6-22
  - in bottom assembly, Option UNL/014/016/080/081
    - illustrated, 6-59, 6-61, 6-63, 6-65
  - in bottom assembly,
    - Option 014/080/081
      - illustrated, 6-47, 6-49
      - part numbers, 6-46
  - in bottom assembly, Option UNL
    - illustrated, 6-27, 6-29
    - part numbers, 6-26, 6-28
  - in bottom assembly, Option UNL/014
    - illustrated, 6-35, 6-37
    - part numbers, 6-34
  - in bottom assembly,
    - Option UNL/014/016
      - illustrated, 6-45
      - part numbers, 6-42
  - in bottom assembly,
    - Option UNL/014/080/081
      - illustrated, 6-51, 6-53, 6-55, 6-57
      - part numbers, 6-50, 6-54
  - in bottom assembly, Option UNL/016
    - illustrated, 6-39, 6-41
    - part numbers, 6-38, 6-40
  - in bottom assembly, Options UNL/014/016/080/081
    - part numbers, 6-58, 6-62
  - in front panel assembly
    - illustrated, 6-11, 6-13
    - part numbers, 6-10, 6-12
  - in hard disk drive (parallel ATA)
    - assembly
      - illustrated, 6-81
  - in hard disk drive (serial ATA)
    - assembly
      - illustrated, 6-83
  - in hard disk drive assembly (parallel ATA)
    - part numbers, 6-80
  - in hard disk drive assembly (serial ATA)
    - part numbers, 6-82
  - in internal analyzer
    - illustrated, 6-75
    - part numbers, 6-74
  - in rear panel assembly
    - illustrated, 6-79
    - part numbers, 6-78
  - in top assembly, Option 080
    - illustrated, 6-19
    - part numbers, 6-18
  - in top assembly, without Option 080
    - illustrated, 6-15
    - part numbers, 6-14
  - locating
    - by reference designator, 6-6
    - by type of part, 6-8
  - miscellaneous
    - part numbers, 6-84
  - replaceable
    - listing of, 6-6
    - ordering information, 6-3
- parts, hardware**
- in bottom assembly
    - illustrated, 6-71, 6-73
    - part numbers, 6-70, 6-72
- password**
- Agilent administrator, 7-67
- performance**
- tests, 3-30
    - calibration coefficients, 3-35
    - description of, 3-7
    - dynamic accuracy, 3-37
    - frequency accuracy, 3-32
    - noise floor, 3-34
    - receiver compression, 3-33
    - source maximum power output, 3-31
    - source power accuracy, 3-30
    - source power linearity, 3-31
    - system crosstalk, 3-36
    - test port crosstalk, 3-36
  - test port output maximum power, 3-31
  - test port output power accuracy, 3-30
  - test port output power linearity, 3-31
  - trace noise, 3-32
  - verification
    - ANSI/NCSL Z540-1-1994, 3-8
    - non-ANSI/NCSL Z540-1-1994, 3-9
- phase lock**
- IF gain adjustment, 3-46
- phase lock board**
- illustrated, 6-15, 6-19
  - operation, 5-10
  - part number, 6-14, 6-18
  - removal and replacement
    - illustrated, 7-21
    - procedure, 7-20
- phase stability check**
- failure of, 3-16
  - test port cables, 3-15
- pin assignments**
- connectors
    - AUX I/O, 5-15
    - HANDLER I/O, 5-14
    - TEST SET I/O, 5-13
- ping**
- command, LAN, 4-20
  - from network, 4-21
  - to analyzer, 4-20
- pixel**
- damaged, 4-15
  - definition, 4-15
- PMYO (permanent-magnet YIG oscillator)**
- frequency adjustment, 3-40
  - theory of operation, 5-10
- Port 1**
- attenuator
    - removal and replacement, 7-58
  - check, 3-10
  - typical power output, 4-38
- Port 2**
- attenuator
    - removal and replacement, 7-58
  - check, 3-10
  - typical power output, 4-39
- post-repair procedures, 7-82**
- power supply**
- check, 4-7
  - functional description of, 5-5
  - functional group, 5-3
  - if all voltages are missing, 4-9
  - operation, 5-33
  - voltage checks, 4-8
- power supply assembly**
- illustrated, 6-15, 6-19
  - part number, 6-14, 6-18
  - removal and replacement
    - illustrated, 7-17

- procedure, 7-16
- troubleshooting, 4-7
- power, source**
  - accuracy test, 3-30
  - linearity test, 3-31
- power, source output**
  - maximum test, 3-31
- power, test port output**
  - accuracy test, 3-30
  - linearity test, 3-31
  - maximum test, 3-31
- precautions**
  - handling airlines, 3-23
- pre-repair**
  - procedures, 7-3
    - caution about, 7-3
    - warnings about, 7-3
- preventive maintenance**
  - effect on error terms, 8-3
- printing copies of documentation**, -iv
- processing subgroup**
  - operation, 5-31
- protection**
  - against ESD, 1-6, 3-4, 4-3, 7-3, 8-4
- protective end caps**
  - for connectors
    - part numbers, 6-84
- PULSE IN connectors**
  - operation, 5-26
- pulse measurement capability, Option H08**, 2-6

## R

- R1 channel**
  - troubleshooting, 4-26
- R1 receiver module**
  - troubleshooting, 4-43
- R1 trace**
  - troubleshooting, 4-26, 4-29
- R2 channel**
  - troubleshooting, 4-26
- R2 receiver module**
  - troubleshooting, 4-43
- R2 trace**
  - troubleshooting, 4-26, 4-29
- rack mount kits**
  - part numbers, 6-86
  - with handles, Option 1CP, 2-5
  - without handles, Option 1CM, 2-5
- raising the receiver deck**
  - illustrated, 7-9
  - procedure, 7-8
- RAM, main**
  - operation, 5-31
- rear panel**
  - connectors
    - 1284-C, 5-32
    - 8.33 MHz IF IN, 5-26
    - AUX I/O, 5-12
  - Display, 5-32
  - EXT 10 MHz REF IN, 5-10
  - EXT 10 MHz REF OUT, 5-10
  - GPIB, 5-32
  - HANDLER I/O, 5-12
  - LAN, 5-32
  - PARALLEL, 5-32
  - PULSE IN, 5-26
  - RS-232, 5-32
  - SERIAL, 5-32
  - TEST SET DRIVERS, 5-26
  - TEST SET I/O, 5-12
  - TRIG IN, 5-12
  - TRIG OUT, 5-12
  - USB, 5-32
  - VGA, 5-32
- interconnects, 5-10, 5-12, 5-32
- replaceable parts
  - illustrated, 6-79
  - part numbers, 6-78
  - troubleshooting, 4-17
- rebuilt-exchange assemblies**
  - program, 6-5
- receiver**
  - accuracy
    - dynamic accuracy test, 3-37
  - calibration, 3-47
  - compression test, 3-33
  - dynamic accuracy test, 3-37
  - frequency offset
    - troubleshooting, 4-47
  - functional description of, 5-4
  - functional group, 5-3
  - linearity
    - dynamic accuracy test, 3-37
  - output
    - troubleshooting, 4-43
- receiver attenuators**
  - description of, 2-4
  - operation, 5-18
  - removal and replacement
    - illustrated, 7-71
    - procedure, 7-70
- receiver deck**
  - raising and removing
    - illustrated, 7-9
    - procedure, 7-8
- receiver display**
  - running the test, 4-26
- receiver group**
  - block diagram, 5-22
  - defined, 4-27
  - operation, 5-21
  - troubleshooting, 4-42
- receiver module**
  - channel A
    - illustrated, 6-23
    - part number, 6-22
  - channel B
    - illustrated, 6-23
    - part number, 6-22
    - removal and replacement illustrated, 7-55
    - removal and replacement procedure, 7-54
  - channel R1
    - illustrated, 6-23
    - part number, 6-22
    - removal and replacement illustrated, 7-55
    - removal and replacement procedure, 7-54
  - channel R2
    - illustrated, 6-23
    - part number, 6-22
    - removal and replacement illustrated, 7-55
    - removal and replacement procedure, 7-54
- receiver motherboard**
  - illustrated, 6-23
  - operation, 5-23
  - part number, 6-22
  - removal and replacement
    - illustrated, 7-57
    - procedure, 7-56
  - troubleshooting, 4-43
- recovery**
  - option data, 8-17
- recovery, operating system**, 8-20
- reference channel R1**. *See R1 channel*
- reference channel R2**. *See R2 channel*
- reference transfer switches**
  - illustrated, 6-47, 6-49, 6-51, 6-53, 6-55, 6-57, 6-59, 6-61, 6-63, 6-65
  - operation, 5-24
  - part number, 6-46, 6-50, 6-54, 6-58, 6-62
  - removal and replacement
    - illustrated, 7-73
    - procedure, 7-72
- reflection tracking**
  - cause of failure, 8-13
  - definition of, 8-13
  - measurements affected by, 8-13
- removing**
  - assemblies. *See specific assembly.*
  - options, 8-16
  - parts. *See specific part.*
- removing the cover**, 1-4
- repair**
  - post-repair procedures, 7-82

- pre-repair procedures, [7-3](#)
- procedures
  - caution about, [7-3](#)
  - warnings about, [7-3](#)
- repairing**
  - option data, [8-17](#)
- replaceable cables**
  - in bottom assembly, Option 014
    - illustrated, [6-31](#), [6-33](#)
    - part numbers, [6-30](#), [6-32](#)
  - in bottom assembly,
    - Option 014/080/081
      - illustrated, [6-47](#), [6-49](#)
      - part numbers, [6-46](#), [6-48](#)
    - in bottom assembly, Option UNL/014
      - illustrated, [6-35](#), [6-37](#)
      - part numbers, [6-34](#), [6-36](#)
    - in bottom assembly,
      - Option UNL/014/016
        - illustrated, [6-45](#)
        - part numbers, [6-42](#), [6-44](#)
      - in bottom assembly,
        - Option UNL/014/016/080/081
          - illustrated, [6-59](#), [6-61](#), [6-63](#), [6-65](#)
          - part numbers, [6-58](#), [6-60](#), [6-62](#), [6-64](#)
        - in bottom assembly,
          - Option UNL/014/080/081
            - illustrated, [6-51](#), [6-53](#), [6-55](#), [6-57](#)
            - part numbers, [6-50](#), [6-52](#), [6-54](#), [6-56](#)
          - in bottom assembly, Option UNL/016
            - illustrated, [6-39](#), [6-41](#)
            - part numbers, [6-38](#), [6-40](#)
          - in top assembly, Option 080
            - illustrated, [6-21](#)
            - part numbers, [6-20](#)
          - in top assembly, without Option 080
            - illustrated, [6-17](#)
            - part numbers, [6-16](#)
    - replaceable cables, flexible**
      - in bottom assembly
        - illustrated, [6-67](#)
        - part numbers, [6-66](#)
    - replaceable cables, ribbon**
      - in bottom assembly
        - illustrated, [6-69](#)
        - part numbers, [6-68](#)
    - replaceable cables, semi-rigid**
      - in bottom assembly, no options
        - illustrated, [6-25](#)
        - part numbers, [6-24](#)
    - replaceable cables, wrapped**
      - in bottom assembly
        - illustrated, [6-69](#)
        - part numbers, [6-68](#)
    - replaceable hardware**
      - in hard disk drive (parallel ATA)
        - part numbers, [6-80](#)
      - in hard disk drive (serial ATA)
        - assembly
          - illustrated, [6-81](#)
        - part numbers, [6-82](#)
      - in hard disk drive (parallel ATA)
        - assembly
          - illustrated, [6-81](#)
        - part numbers, [6-82](#)
      - in hard disk drive (serial ATA)
        - assembly
          - illustrated, [6-83](#)
        - part numbers, [6-82](#)
      - in hard disk drive (serial ATA)
        - assembly
          - illustrated, [6-75](#)
        - part numbers, [6-74](#)
      - in internal analyzer
        - illustrated, [6-75](#)
        - part numbers, [6-74](#)
    - replaceable parts**
      - external analyzer
        - illustrated, [6-77](#)
        - part numbers, [6-76](#)
      - hardware, in bottom assembly
        - part numbers, [6-70](#), [6-72](#)
      - in bottom assembly, no hardware
        - options
          - illustrated, [6-23](#)
          - part numbers, [6-22](#)
      - in bottom assembly,
        - Option 014/080/081
          - illustrated, [6-47](#), [6-49](#)
          - part numbers, [6-46](#)
        - in bottom assembly, Option UNL, [6-26](#), [6-28](#)
          - illustrated, [6-27](#), [6-29](#)
        - in bottom assembly, Option UNL/014, [6-34](#)
          - illustrated, [6-35](#), [6-37](#)
        - in bottom assembly,
          - Option UNL/014/016
            - illustrated, [6-45](#)
            - part numbers, [6-42](#)
          - in bottom assembly,
            - Option UNL/014/016/080/081, [6-58](#), [6-62](#)
              - illustrated, [6-59](#), [6-61](#), [6-63](#), [6-65](#)
            - in bottom assembly,
              - Option UNL/014/080/081, [6-50](#), [6-54](#)
                - illustrated, [6-51](#), [6-53](#), [6-55](#), [6-57](#)
              - in bottom assembly, Option UNL/016
                - illustrated, [6-39](#), [6-41](#)
                - part numbers, [6-38](#), [6-40](#)
              - in front panel assembly
                - illustrated, [6-11](#), [6-13](#)
                - part numbers, [6-10](#), [6-12](#)
              - in hard disk drive (parallel ATA)
                - part numbers, [6-80](#)
              - in hard disk drive (parallel ATA)
                - assembly
                  - illustrated, [6-81](#)
                - part numbers, [6-82](#)
              - in hard disk drive (serial ATA)
                - assembly
                  - illustrated, [6-83](#)
                - part numbers, [6-82](#)
              - in internal analyzer
                - illustrated, [6-75](#)
                - part numbers, [6-74](#)
              - in hard disk drive (serial ATA)
                - assembly
                  - illustrated, [6-83](#)
                - part numbers, [6-74](#)
              - in internal analyzer
                - illustrated, [6-75](#)
                - part numbers, [6-74](#)
              - in rear panel assembly
                - illustrated, [6-79](#)
                - part numbers, [6-78](#)
              - in top assembly, Option 080, [6-18](#)
                - illustrated, [6-19](#)
              - in top assembly, without Option 080, [6-14](#)
                - illustrated, [6-15](#)
              - listing of, [6-6](#)
              - locating
                - by reference designator, [6-6](#)
                - by type of part, [6-8](#)
              - miscellaneous analyzer
                - part numbers, [6-84](#)
              - ordering information, [6-3](#)
            - replaceable parts, hardware**
              - in bottom assembly
                - illustrated, [6-71](#), [6-73](#)
            - replacement**
              - 30-dB attenuators
                - procedure, [7-46](#)
              - A1 keypad assembly
                - illustrated, [7-13](#)
                - procedure, [7-14](#)
              - A10 frequency reference board
                - illustrated, [7-19](#)
                - procedure, [7-18](#)
              - A11 phase lock board
                - illustrated, [7-21](#)
                - procedure, [7-20](#)
              - A12 source 20
                - illustrated, [7-23](#)
                - procedure, [7-22](#)
              - A13 phase lock receiver board
                - illustrated, [7-25](#)
                - procedure, [7-24](#)
              - A14 motherboard
                - illustrated, [7-27](#)
                - procedure, [7-26](#)
              - A15 CPU board
                - illustrated, [7-30](#)
                - procedure, [7-28](#)
              - A16 test set motherboard
                - illustrated, [7-33](#)
                - procedure, [7-32](#)
              - A17 LOMA 10
                - illustrated, [7-35](#)
                - procedure, [7-34](#)
              - A18 MA 20
                - illustrated, [7-37](#)
                - procedure, [7-36](#)
              - A19 splitter



- illustrated, [7-39](#)
- procedure, [7-38](#)
- A2 display assembly
  - illustrated, [7-13](#)
  - procedure, [7-13](#)
- A20 LODA
  - illustrated, [7-41](#)
  - procedure, [7-40](#)
- A21 SOMA 50
  - illustrated, [7-43](#)
  - procedure, [7-42](#)
- A22 switch splitter
  - illustrated, [7-45](#)
  - procedure, [7-44](#)
- A23 channel R1 detector
  - illustrated, [7-49](#)
  - procedure, [7-48](#)
- A24 channel R2 detector
  - illustrated, [7-49](#)
  - procedure, [7-48](#)
- A25 test port 1 coupler
  - illustrated, [7-51](#)
  - procedure, [7-50](#)
- A26 test port 2 coupler
  - illustrated, [7-51](#)
  - procedure, [7-50](#)
- A27 channel A first converter
  - illustrated, [7-53](#)
  - procedure, [7-52](#)
- A28 channel R1 first converter
  - illustrated, [7-53](#)
  - procedure, [7-52](#)
- A29 channel R2 first converter
  - illustrated, [7-53](#)
  - procedure, [7-52](#)
- A3 front panel interface board
  - illustrated, [7-13](#)
  - procedure, [7-14](#)
- A30 channel B first converter
  - illustrated, [7-53](#)
  - procedure, [7-52](#)
- A31 channel A receiver module
  - illustrated, [7-55](#)
  - procedure, [7-54](#)
- A32 channel R1 receiver module
  - illustrated, [7-55](#)
  - procedure, [7-54](#)
- A33 channel R2 receiver module
  - illustrated, [7-55](#)
  - procedure, [7-54](#)
- A34 channel B receiver module
  - illustrated, [7-55](#)
  - procedure, [7-54](#)
- A35 receiver motherboard
  - illustrated, [7-57](#)
  - procedure, [7-56](#)
- A36 port 1 60-dB step attenuator
  - illustrated, [7-59](#)
  - procedure, [7-58](#)
- A37 port 2 60-dB step attenuator
  - illustrated, [7-59](#)
  - procedure, [7-58](#)
- A38 port 1 bias tee
  - illustrated, [7-61](#)
  - procedure, [7-60](#)
- A39 port 2 bias tee
  - illustrated, [7-61](#)
  - procedure, [7-60](#)
- A4 power supply assembly
  - illustrated, [7-17](#)
  - procedure, [7-16](#)
- A41 hard disk drive
  - illustrated, [7-63](#)
  - procedure, [7-62](#)
- A43 channel A 35-dB step attenuator
  - illustrated, [7-71](#)
  - procedure, [7-70](#)
- A44 channel B 35-dB step attenuator
  - illustrated, [7-71](#)
  - procedure, [7-70](#)
- A45 reference transfer switch
  - illustrated, [7-73](#)
  - procedure, [7-72](#)
- A46 reference transfer switch
  - illustrated, [7-73](#)
  - procedure, [7-72](#)
- A47 RF path coupler
  - illustrated, [7-75](#)
  - procedure, [7-74](#)
- A48 LO path coupler
  - illustrated, [7-75](#)
  - procedure, [7-74](#)
- A49 IF multiplexer board
  - illustrated, [7-55](#)
  - procedure, [7-54](#)
- A6 SPAM board
  - illustrated, [7-19](#)
  - procedure, [7-18](#)
- A8 fractional-N synthesizer board
  - illustrated, [7-19](#)
  - procedure, [7-18](#)
- A9 fractional-N synthesizer board
  - illustrated, [7-19](#)
  - procedure, [7-18](#)
- analyzer covers
  - illustrated, [7-7](#)
  - procedure, [7-6](#)
- assembly
  - cautions about, [7-3](#)
  - list of procedures, [7-4](#)
  - sequence, [6-4](#), [7-3](#)
  - warnings about, [7-3](#)
- attenuators, 30 dB
  - illustrated, [7-47](#)
- attenuators, 30-dB
  - procedure, [7-46](#)
- fan, [7-76](#)
- front panel assembly
  - illustrated, [7-11](#)
  - procedure, [7-10](#)
- front panel subassemblies
  - illustrated, [7-13](#)
  - procedures, [7-12](#)
- IF multiplexer board
  - illustrated, [7-55](#)
  - procedure, [7-54](#)
- inverter board
  - illustrated, [7-13](#)
  - procedure, [7-12](#)
- lithium battery
  - illustrated, [7-81](#)
  - procedure, [7-80](#)
- midweb
  - illustrated, [7-77](#)
  - procedure, [7-76](#)
- raising the receiver deck
  - illustrated, [7-9](#)
  - procedure, [7-8](#)
- touch screen controller board
  - illustrated, [7-13](#)
  - procedure, [7-12](#)
- touch screen display
  - illustrated, [7-15](#)
- touch screen display assembly
  - illustrated, [7-13](#)
  - procedure, [7-15](#)
- USB connector board
  - illustrated, [7-13](#)
  - procedure, [7-14](#)
- USB hub
  - illustrated, [7-79](#)
  - procedure, [7-79](#)
- replacement sequence**, [4-3](#)
- return loss check**
  - failure of, [3-13](#)
  - test port cables, [3-13](#)
- RF path coupler**
  - removal and replacement
    - illustrated, [7-75](#)
    - procedure, [7-74](#)
- RF path coupler, A47**
  - operation, [5-26](#)
- RF signal**
  - troubleshooting, [4-32](#)
- RFI/EMI**
  - supplies
    - part numbers, [6-86](#)
- rotary pulse generator (RPG)**
  - illustrated, [6-11](#)
  - part number, [6-10](#)
  - test, [4-15](#)
  - troubleshooting, [4-12](#)

**RS-232 port**  
rear panel connector, 5-32  
troubleshooting, 4-18

## S

### safety

considerations, 1-3  
earth ground, 1-3  
symbols, 1-3

### SCPI, 8-9

### screws

for bottom assemblies  
illustrated, 6-71, 6-73  
part numbers, 6-70, 6-72

### serial number

changing, 8-18  
installing, 8-18

### SERIAL port

rear panel connector, 5-32  
troubleshooting, 4-18

### service

EMI/RFI parts  
part numbers, 6-86  
options, 2-11

### procedures

caution about, 7-3  
post-repair, 7-82  
pre-repair, 7-3  
warnings about, 7-3

### static safety parts

part numbers, 6-86  
required, 2-10

test equipment  
required, 2-8

### tools

part numbers, 6-84  
required, 2-10

warnings, 1-4

### warranty

one-year return to Agilent, 2-11  
standard, 2-11

### shipment for service or repair, 2-12

### signal separation

functional description of, 5-4  
functional group, 5-3

### signal separation group

block diagram, 5-17  
defined, 4-27  
operation, 5-16  
troubleshooting, 4-38

### single band failure, 4-31

### software

options, 8-16

### SOMA 50

illustrated, 6-23  
operation, 5-11  
part number, 6-22  
removal and replacement

illustrated, 7-43

procedure, 7-42

troubleshooting, 4-32

### source

calibration, 3-45  
functional group, 5-3  
maximum output power test, 3-31  
operation, 5-6  
power accuracy test, 3-30  
power linearity test, 3-31

### source 20

illustrated, 6-15, 6-19  
operation, 5-10  
part numbers, 6-14, 6-18  
removal and replacement  
illustrated, 7-23  
procedure, 7-22  
troubleshooting, 4-32  
any band, 4-46

### source attenuators

description of, 2-6  
operation, 5-18  
removal and replacement  
illustrated, 7-59  
procedure, 7-58

### source group

block diagram, 5-7  
defined, 4-27  
troubleshooting, 4-30

### source match

cause of failure, 8-12  
definition of, 8-12  
measurements affected by, 8-12

### SPAM board

illustrated, 6-15, 6-19  
operation  
analog, 5-23  
digital, 5-31  
part number, 6-14, 6-18  
removal and replacement  
illustrated, 7-19  
procedure, 7-18  
troubleshooting, 4-43

### speaker

front panel, 5-30  
troubleshooting, 4-12

### specifications

instrument, 3-6  
stabilization, warm up time, 3-4  
system, 3-6

### splitter

illustrated, 6-23  
operation, 5-9  
part number, 6-22  
removal and replacement  
illustrated, 7-39  
procedure, 7-38

### stabilization

warm up time, 3-4

### standards compliant calibration

built-in tests, Option 898, 2-6

### static safety parts

required for servicing, 2-10

### step attenuator, receiver

illustrated, 6-39, 6-41, 6-45  
operation, 5-18  
part number, 6-38, 6-40, 6-42, 6-58, 6-62

### removal and replacement

illustrated, 7-71  
procedure, 7-70

### step attenuator, source

illustrated, 6-27, 6-29, 6-35, 6-37, 6-39, 6-41, 6-45, 6-51, 6-53, 6-55, 6-57, 6-59, 6-61, 6-63, 6-65

operation, 5-18

part number, 6-26, 6-28, 6-34, 6-38, 6-40, 6-42, 6-50, 6-54, 6-58, 6-62

### port 1

troubleshooting, 4-40

### port 2

troubleshooting, 4-40

### port 1

illustrated, 6-27, 6-29, 6-35, 6-37, 6-39, 6-41, 6-45, 6-51, 6-53, 6-55, 6-57, 6-59, 6-61, 6-63, 6-65

part number, 6-26, 6-28, 6-34, 6-38, 6-40, 6-42, 6-50, 6-54, 6-58, 6-62

### port 2

illustrated, 6-27, 6-29, 6-35, 6-37, 6-39, 6-41, 6-45, 6-51, 6-53, 6-55, 6-57, 6-59, 6-61, 6-63, 6-65

part number, 6-26, 6-28, 6-34, 6-38, 6-40, 6-42, 6-50, 6-54, 6-58, 6-62

### removal and replacement

illustrated, 7-59  
procedure, 7-58

### storage data

IDE, 5-32

### strap handle

analyzer  
illustrated, 6-77  
part number, 6-76

### subgroup

data acquisition and processing, 5-28  
front panel, 5-28

### subnet mask, LAN, 4-20

### substitution

cable, 3-22  
calibration kits, 3-22  
verification kits, 3-22

### supplies

- EMI/RFI
    - part numbers, 6-86
  - ESD
    - part numbers, 6-86
  - support**
    - options, 2-11
    - organization, 2-11
  - switch splitter**
    - illustrated, 6-23
    - operation, 5-16
    - part number, 6-22
    - removal and replacement
      - illustrated, 7-45
      - procedure, 7-44
    - troubleshooting, 4-40
  - switch, reference transfer**
    - removal and replacement
      - illustrated, 7-73
      - procedure, 7-72
  - synthesized source**
    - functional description of, 5-4
  - system**
    - adjustments, 3-1, 3-38
      - frequency at 10 MHz, 3-39
      - frequency at 3.8 MHz, 3-40
      - getting ready, 3-4
      - LO offset, 3-43
      - LO power, 3-41
      - phase lock IF gain, 3-46
      - receiver calibration, 3-47
      - source calibration, 3-45
    - checks, 3-1
      - getting ready, 3-4
    - cross talk test, 3-36
    - operating
      - recovery, 8-20
    - specifications, 3-6
    - verification, 3-1, 3-7, 3-19
      - device connections, 3-25
      - dialog box, 3-24
      - example of results, 3-27, 3-28
      - failure flowchart, 3-26
      - failure of, 3-26
      - getting ready, 3-4
      - interpreting results, 3-27
      - performing, 3-22
      - procedure, 3-24
      - test setup, 3-24
      - what it verifies, 3-19
  - system motherboard**
    - illustrated, 6-15, 6-19
    - operation, 5-30
    - part number, 6-14, 6-18
    - removal and replacement
      - illustrated, 7-27
      - procedure, 7-26
    - troubleshooting, 4-11
- T**
- test**
    - calibration coefficients, 3-35
    - dynamic accuracy, 3-37
    - frequency accuracy, 3-32
    - noise floor, 3-34
    - performance
      - frequency accuracy, 3-32
      - source maximum power output, 3-31
      - source power accuracy, 3-30
      - test port maximum power output, 3-31
      - test port power accuracy, 3-30
    - receiver compression, 3-33
    - source power linearity, 3-31
    - system crosstalk, 3-36
    - test port crosstalk, 3-36
    - test port output power linearity, 3-31
    - trace noise, 3-32
  - test equipment**
    - required for service, 2-8
    - required for servicing, 2-8
  - test port**
    - cable checks
      - connector repeatability failure, 3-18
    - coupler nut
      - illustrated, 6-71, 6-73
      - part number, 6-70, 6-72
    - cross talk test, 3-36
    - dynamic accuracy test, 3-37
    - maximum output power test, 3-31
    - noise floor test, 3-34
    - output power accuracy test, 3-30
    - output power linearity test, 3-31
  - test port 1 coupler**
    - illustrated, 6-23
    - operation, 5-17
    - part number, 6-22
    - removal and replacement
      - illustrated, 7-51
      - procedure, 7-50
    - troubleshooting, 4-40
  - test port 2 coupler**
    - illustrated, 6-23
    - operation, 5-17
    - part number, 6-22
    - removal and replacement
      - illustrated, 7-51
      - procedure, 7-50
    - troubleshooting, 4-40
  - test port cable**
    - checks, 3-10
      - accessories used in, 3-12
      - connector repeatability, 3-17
      - insertion loss, 3-14
      - insertion loss failure, 3-14
      - magnitude and phase stability, 3-15
      - magnitude and phase stability failure, 3-16
      - performing, 3-12
      - return loss, 3-13
      - return loss failure, 3-13
  - TEST SET DRIVERS connectors**
    - operation, 5-26
  - TEST SET I/O**
    - connector
      - pin assignments, 5-13
      - rear panel, 5-12
  - test set motherboard**
    - illustrated, 6-23
    - operation, 5-12
    - part number, 6-22
    - removal and replacement
      - illustrated, 7-33
      - procedure, 7-32
  - test setup**
    - system verification, 3-24
  - tests**
    - adjustments, 3-38
    - frequency offset group (option 080), 4-44
    - N7840A software, 3-30
    - performance, 3-7, 3-30
    - source group, 4-31
  - time domain, Option 010, 2-3**
  - tools**
    - required for servicing, 2-10
    - service, part numbers, 6-84
  - top assembly, Option 080**
    - replaceable cables
      - illustrated, 6-21
      - part numbers, 6-20
    - replaceable parts
      - illustrated, 6-19
      - part numbers, 6-18
  - top assembly, without Option 080**
    - replaceable parts
      - part numbers, 6-14
  - top assembly, without Option 080**
    - replaceable cables
      - illustrated, 6-17
      - part numbers, 6-16
    - replaceable parts
      - illustrated, 6-15
  - touch screen controller board**
    - removal and replacement
      - illustrated, 7-13
      - procedure, 7-12
  - touch screen display**
    - removal and replacement
      - illustrated, 7-15
  - touch screen display assembly**
    - removal and replacement
      - illustrated, 7-13
      - procedure, 7-15

- touch-up**
  - paint
    - part numbers, 6-86
- trace**
  - troubleshooting all, 4-26, 4-28
- trace A**
  - troubleshooting, 4-26, 4-29
- trace B**
  - troubleshooting, 4-26, 4-29
- trace noise**
  - test, 3-32
- trace R1**
  - troubleshooting, 4-26, 4-29
- trace R2**
  - troubleshooting, 4-26, 4-29
- traceability**
  - measurement, 3-21
  - path, 3-21
- transfer switches**
  - description of, 2-5
  - illustrated, 6-47, 6-49, 6-51, 6-53, 6-55, 6-57, 6-59, 6-61, 6-63, 6-65
  - operation, 5-24
  - part number, 6-46, 6-50, 6-54, 6-58, 6-62
  - removal and replacement
    - illustrated, 7-73
    - procedure, 7-72
- transmission tracking**
  - cause of failure, 8-13
  - definition of, 8-13
- TRIG IN connector**
  - rear panel, 5-12
- TRIG OUT connector**
  - rear panel, 5-12
- troubleshooting**
  - 1284-C port, 4-18
  - A10 frequency reference board, 4-32, 4-33, 4-44
  - A12 source 20, 4-31, 4-32
    - any band, 4-46
  - A13 frequency offset receiver, 4-47
  - A14 motherboard, 4-11
  - A15 CPU board, 4-17
  - A17 LOMA 10, 4-34
  - A18 MA 20, 4-37
  - A2 display assembly, 4-12
  - A20 LODA, 4-37
  - A21 SOMA 50, 4-32
  - A22 switch splitter, 4-40
  - A25 test port 1 coupler, 4-40
  - A26 test port 2 coupler, 4-40
  - A27 channel A first converter, 4-42
  - A28 channel R1 first converter, 4-42
  - A29 channel R2 first converter, 4-42
  - A3 front panel interface board, 4-12
  - A30 channel B first converter, 4-42
  - A31 channel A receiver module, 4-43
  - A32 channel R1 receiver module, 4-43
  - A33 channel R2 receiver module, 4-43
  - A34 channel B receiver module, 4-43
  - A35 receiver motherboard, 4-43
  - A36 port 1 step attenuator, 4-40
  - A37 port 2 step attenuator, 4-40
  - A38 port 1 bias tee, 4-41
  - A39 port 2 bias tee, 4-41
  - A4 power supply assembly, 4-7
  - A45 reference transfer switch, 4-47
  - A46 reference transfer switch, 4-47
  - A6 SPAM board, 4-43
  - A8 fractional-N synthesizer board
    - band 2, 4-34
    - bands 0 and 1, 4-33
    - bands 3–25, 4-34
  - A9 fractional-N synthesizer board
    - band 2, 4-45
    - bands 0 and 1, 4-45
    - bands 3–25, 4-46
  - any band, 4-46
  - band 2, 4-34
  - band 2 for A9, 4-45
  - bands 0 and 1, 4-33
  - bands 0 and 1 for A9, 4-45
  - bands 3–25, 4-34
  - bands 3–25 for A9, 4-46
  - channel A, 4-26, 4-38
  - channel B, 4-26, 4-38
  - channel R1, 4-26
  - channel R2, 4-26
  - check the basics, 4-4
  - error term failure
    - suspect devices, 8-3
  - fans, 4-11
  - front panel, 4-12
  - front panel keypad, 4-12
  - front panel knob, 4-12
  - front-panel USB, 4-12
  - GPIB port, 4-18
  - IF multiplexer board, 4-43
  - LAN, 4-20
  - measurement system, 4-24
    - frequency offset (080) group, 4-44
    - frequency offset group (option 080), 4-44
    - receiver group, 4-42
    - running the receiver display, 4-26
    - signal separation group, 4-38
    - source group, 4-30, 4-31
    - traces A, B, R1, R2, 4-26
    - where to begin, 4-27
  - order of removal of boards, 4-9
  - PARALLEL port, 4-18
  - ping command, 4-20
  - power output of channel A, 4-38
  - power output of channel B, 4-38
  - power up, 4-6
  - power supply check, 4-7
  - rear panel, 4-17
  - rear-panel USB, 4-17
  - receiver output, 4-43
  - RF signal, 4-32
  - RPG, 4-12
  - RS-232 port, 4-18
  - SERIAL port, 4-18
  - source 20, 4-31
  - source group
    - RF signal, 4-32
    - single vs. broadband, 4-31
  - speaker, 4-12
  - trace A, 4-26
  - trace B, 4-26
  - trace R1, 4-26
  - trace R2, 4-26
  - typical power output
    - Port 1, 4-38
    - Port 2, 4-39
  - using controllers to system
    - troubleshoot, 4-19
  - using error terms, 8-3
  - using the extender board, 4-8
  - VGA port, 4-18
  - where to begin, 4-4

## U

- uncertainty**
  - measurement, 3-20
- upgrade**
  - configurable test set, Option 014, 2-3
  - firmware
    - downloading from the internet, 8-19
  - how to order, 2-3, 2-6
  - IF access, Option H11, 2-6
  - pulse measurement capability,
    - Option H08, 2-6
  - source attenuator, Option UNL, 2-6
  - time domain, Option 010, 2-3
- upgrade kits**
  - part numbers, 6-85
- upgrade kits, E8362C**
  - part numbers, 6-85
- upgrade kits, E8363C**
  - part numbers, 6-85
- upgrade kits, E8364C**
  - part numbers, 6-85
- upgrade, extended frequency to 40 GHz**
  - Option 040, 2-4
- upgrade, extended frequency to 50 GHz**
  - Option 050, 2-4
- upgrade, extended frequency to 67 GHz**
  - Option 067, 2-4
- upgrade, firmware**
  - Option 099, 2-5
- upgrade, frequency offset mode**

- Option 080, [2-4](#)
- upgrade, receiver attenuator**
  - Option 016, [2-4](#)
- upgrade, reference transfer switch**
  - Option 081, [2-5](#)
- upgrades**
  - analyzer, [2-6](#)
- USB**
  - accessories
    - CD-RW drive, [2-7](#)
    - hub, [2-7](#)
    - part numbers, [6-86](#)
  - port
    - front panel connector, [5-30](#)
    - rear panel connector, [5-32](#)
  - rear panel
    - troubleshooting, [4-17](#)
- USB board**
  - troubleshooting, [4-12](#)
- USB connector board**
  - removal and replacement
    - illustrated, [7-13](#)
    - procedure, [7-14](#)
- USB hub**
  - illustrated, [6-15](#), [6-19](#)
  - operation, [5-32](#)
  - part number, [6-14](#), [6-18](#)
  - removal and replacement, [7-79](#)
    - illustrated, [7-79](#)
- utility**
  - option enable
    - accessing, [8-15](#)
    - dialog box, [8-15](#)

## V

- VCO (voltage-controlled oscillator)**
  - defined, [5-6](#)
- ventilation requirements**, [1-3](#)
- verification**
  - ANSI/NCSL Z540-1-1994, [3-8](#)
    - kits, [2-9](#), [3-7](#)
      - substitution, [3-22](#)
  - non-ANSI/NCSL Z540-1-1994, [3-9](#)
  - of operating environment, [3-4](#)
  - of operating specifications, [3-4](#)
  - of Option H11, IF access, [3-29](#)
  - system, [3-1](#), [3-7](#), [3-19](#)
    - device connections, [3-25](#)
    - dialog box, [3-24](#)
    - example of results, [3-27](#), [3-28](#)
    - failure flowchart, [3-26](#)
    - failure of, [3-26](#)
    - getting ready, [3-4](#)
    - interpreting results, [3-27](#)
    - performing, [3-22](#)
    - procedure, [3-24](#)
    - test setup, [3-24](#)

- what it verifies, [3-19](#)
- VGA port**
  - rear panel connector, [5-32](#)
  - troubleshooting, [4-18](#)

## W

- warm up**
  - analyzer, [3-4](#)
- warning**, [1-3](#)
- warnings**
  - for servicing, [1-4](#)
- warranty**
  - service
    - one-year return to Agilent, [2-11](#)
    - standard, [2-11](#)
- Windows**, [2-8](#)

## Y

- YIG (yttrium-iron-garnet)**
  - defined, [5-6](#)
- YIG oscillator**
  - PMYO frequency adjustment, [3-40](#)
- YTO (YIG-tuned oscillator)**
  - defined, [5-10](#)
  - theory of operation, [5-10](#)

