

# **Operating Manual**

## **Agilent Technologies**

### **8757D**

## **Scalar Network Analyzer**



**Agilent Technologies**

**Manufacturing Part Number: 08757-90109**

**Printed in USA**

**Print Date: March 2005**

**Supersedes: November 2000**

© Agilent Technologies, Inc. 1993, 2000, 2005

---

## **Hewlett-Packard to Agilent Technologies Transition**

This manual may contain references to HP or Hewlett-Packard. Please note that Hewlett-Packard's former test and measurement, semiconductor products and chemical analysis businesses are now part of Agilent Technologies. To reduce potential confusion, the only change to product numbers and names has been in the company name prefix: where a product number/name was HP XXXX the current name/number is now Agilent XXXX. For example, model number HP 8757D is now model number Agilent 8757D.

---

## **Documentation Warranty**

THE MATERIAL CONTAINED IN THIS DOCUMENT IS PROVIDED "AS IS," AND IS SUBJECT TO BEING CHANGED, WITHOUT NOTICE, IN FUTURE EDITIONS. FURTHER, TO THE MAXIMUM EXTENT PERMITTED BY APPLICABLE LAW, AGILENT DISCLAIMS ALL WARRANTIES, EITHER EXPRESS OR IMPLIED WITH REGARD TO THIS MANUAL AND ANY INFORMATION CONTAINED HEREIN, INCLUDING BUT NOT LIMITED TO THE IMPLIED WARRANTIES OF MERCHANTABILITY AND FITNESS FOR A PARTICULAR PURPOSE. AGILENT SHALL NOT BE LIABLE FOR ERRORS OR FOR INCIDENTAL OR CONSEQUENTIAL DAMAGES IN CONNECTION WITH THE FURNISHING, USE, OR PERFORMANCE OF THIS DOCUMENT OR ANY INFORMATION CONTAINED HEREIN. SHOULD AGILENT AND THE USER HAVE A SEPARATE WRITTEN AGREEMENT WITH WARRANTY TERMS COVERING THE MATERIAL IN THIS DOCUMENT THAT CONFLICT WITH THESE TERMS, THE WARRANTY TERMS IN THE SEPARATE AGREEMENT WILL CONTROL.

---

## **DFARS/Restricted Rights Notice**

If software is for use in the performance of a U.S. Government prime contract or subcontract, Software is delivered and licensed as "Commercial computer software" as defined in DFAR 252.227-7014 (June 1995), or as a "commercial item" as defined in FAR 2.101(a) or as "Restricted computer software" as defined in FAR 52.227-19 (June 1987) or any equivalent agency regulation or contract clause. Use, duplication or disclosure of Software is subject to Agilent Technologies' standard commercial license terms, and non-DOD Departments and Agencies of the U.S. Government will receive no greater than Restricted Rights as defined in FAR 52.227-19(c)(1-2) (June 1987). U.S. Government users will receive no greater than Limited Rights as defined in FAR 52.227-14 (June 1987) or DFAR 252.227-7015 (b)(2) (November 1995), as applicable in any technical data.

---

---

## Printing Copies of Documentation from the Web

To print copies of documentation from the Web, download the PDF file from the Agilent web site:

- Go to <http://www.agilent.com>.
  - Enter the document's part number (located on the title page) in the **Quick Search** box.
  - Click GO.
  - Click on the hyperlink for the document.
  - Click the printer icon located in the tool bar.
-

# Contacting Agilent

This information supersedes all prior HP contact information.

**Online assistance:** [www.agilent.com/find/assist](http://www.agilent.com/find/assist)

Americas			
<b>Brazil</b> <i>(tel)</i> (+55) 11 3351 7012 <i>(fax)</i> (+55) 11 3351 7024	<b>Canada</b> <i>(tel)</i> +1 877 894 4414 <i>(fax)</i> +1 303 662 3369	<b>Mexico</b> <i>(tel)</i> 1 800 254 2440 <i>(fax)</i> 1 800 254 4222	<b>United States</b> <i>(tel)</i> 800 829 4444 <i>(alt)</i> (+1) 303 662 3998 <i>(fax)</i> 800 829 4433
Asia Pacific and Japan			
<b>Australia</b> <i>(tel)</i> 1 800 225 574 <i>(fax)</i> 1 800 681 776 <i>(fax)</i> 1 800 225 539	<b>China</b> <i>(tel)</i> 800 810 0508 <i>(alt)</i> 800 810 0510 <i>(fax)</i> 800 810 0507 <i>(fax)</i> 800 810 0362	<b>Hong Kong</b> <i>(tel)</i> 800 933 229 <i>(fax)</i> 800 900 701	<b>India</b> <i>(tel)</i> 1600 112 626 <i>(fax)</i> 1600 112 727 <i>(fax)</i> 1600 113 040
<b>Japan (Bench)</b> <i>(tel)</i> 0120 32 0119 <i>(alt)</i> (+81) 426 56 7799 <i>(fax)</i> 0120 01 2144	<b>Japan (On-Site)</b> <i>(tel)</i> 0120 802 363 <i>(alt)</i> (+81) 426 56 7498 <i>(fax)</i> (+81) 426 60 8953	<b>Singapore</b> <i>(tel)</i> 1 800 275 0880 <i>(fax)</i> (+65) 6755 1235 <i>(fax)</i> (+65) 6755 1214	<b>South Korea</b> <i>(tel)</i> 080 778 0011 <i>(fax)</i> 080 778 0013
<b>Taiwan</b> <i>(tel)</i> 0800 047 669 <i>(fax)</i> 0800 047 667 <i>(fax)</i> 886 3492 0779	<b>Thailand</b> <i>(tel)</i> 1 800 2758 5822 <i>(alt)</i> (+66) 2267 5913 <i>(fax)</i> 1 800 656 336	<b>Malaysia</b> <i>(tel)</i> 1800 880 399 <i>(fax)</i> 1800 801 054	
Europe			
<b>Austria</b> <i>(tel)</i> 0820 87 44 11* <i>(fax)</i> 0820 87 44 22	<b>Belgium</b> <i>(tel)</i> (+32) (0)2 404 9340 <i>(alt)</i> (+32) (0)2 404 9000 <i>(fax)</i> (+32) (0)2 404 9395	<b>Denmark</b> <i>(tel)</i> (+45) 7013 1515 <i>(alt)</i> (+45) 7013 7313 <i>(fax)</i> (+45) 7013 1555	<b>Finland</b> <i>(tel)</i> (+358) 10 855 2100 <i>(fax)</i> (+358) (0) 10 855 2923
<b>France</b> <i>(tel)</i> 0825 010 700* <i>(alt)</i> (+33) (0)1 6453 5623 <i>(fax)</i> 0825 010 701*	<b>Germany</b> <i>(tel)</i> 01805 24 6333* <i>(alt)</i> 01805 24 6330* <i>(fax)</i> 01805 24 6336*	<b>Ireland</b> <i>(tel)</i> (+353) (0)1 890 924 204 <i>(alt)</i> (+353) (0)1 890 924 206 <i>(fax)</i> (+353) (0)1 890 924 024	<b>Israel</b> <i>(tel)</i> (+972) 3 9288 500 <i>(fax)</i> (+972) 3 9288 501
<b>Italy</b> <i>(tel)</i> (+39) (0)2 9260 8484 <i>(fax)</i> (+39) (0)2 9544 1175	<b>Luxemburg</b> <i>(tel)</i> (+32) (0)2 404 9340 <i>(alt)</i> (+32) (0)2 404 9000 <i>(fax)</i> (+32) (0)2 404 9395	<b>Netherlands</b> <i>(tel)</i> (+31) (0)20 547 2111 <i>(alt)</i> (+31) (0)20 547 2000 <i>(fax)</i> (+31) (0)20 547 2190	<b>Russia</b> <i>(tel)</i> (+7) 095 797 3963 <i>(alt)</i> (+7) 095 797 3900 <i>(fax)</i> (+7) 095 797 3901
<b>Spain</b> <i>(tel)</i> (+34) 91 631 3300 <i>(alt)</i> (+34) 91 631 3000 <i>(fax)</i> (+34) 91 631 3301	<b>Sweden</b> <i>(tel)</i> 0200 88 22 55* <i>(alt)</i> (+46) (0)8 5064 8686 <i>(fax)</i> 020 120 2266*	<b>Switzerland (French)</b> <i>(tel)</i> 0800 80 5353 opt. 2* <i>(alt)</i> (+33) (0)1 6453 5623 <i>(fax)</i> (+41) (0)22 567 5313	<b>Switzerland (German)</b> <i>(tel)</i> 0800 80 5353 opt. 1* <i>(alt)</i> (+49) (0)7031 464 6333 <i>(fax)</i> (+41) (0)1 272 7373
<b>Switzerland (Italian)</b> <i>(tel)</i> 0800 80 5353 opt. 3* <i>(alt)</i> (+39) (0)2 9260 8484 <i>(fax)</i> (+41) (0)22 567 5314	<b>United Kingdom</b> <i>(tel)</i> (+44) (0)7004 666666 <i>(alt)</i> (+44) (0)7004 123123 <i>(fax)</i> (+44) (0)7004 444555		
<i>(tel)</i> = primary telephone number; <i>(alt)</i> = alternate telephone number; <i>(fax)</i> = FAX number; * = in country number 11/16/04			

# Contents

---

## Table of Contents

<b>1. General Information</b>	
Safety Considerations . . . . .	1-2
The HP 8757D Analyzer . . . . .	1-6
CRT/LCD Attributes . . . . .	1-6
Displays . . . . .	1-6
Peripherals . . . . .	1-6
Calibration Data and Instrument States . . . . .	1-6
Measurement Channels . . . . .	1-6
Local and Remote Operation . . . . .	1-6
Options Available . . . . .	1-7
Specifications, General Requirements, and Operating Characteristics . . . . .	1-9
Manufacturer's Declarations . . . . .	1-17
Accessories and Supplies . . . . .	1-20
<b>2. Installation</b>	
Introduction . . . . .	2-1
Initial Inspection . . . . .	2-2
Operating Environment . . . . .	2-3
Electrostatic Discharge . . . . .	2-4
Power Requirements . . . . .	2-5
Checking the Line Voltage and Fuse . . . . .	2-5
Checking the Power Cable . . . . .	2-6
Equipment Required But Not Supplied . . . . .	2-7
AC Detection . . . . .	2-7
Firmware Compatibility . . . . .	2-7
Rack Mounting . . . . .	2-8
Connecting the Analyzer to a Source . . . . .	2-10
External Modulation . . . . .	2-10
Other Configurations . . . . .	2-10
Connecting the Analyzer to an External Monitor . . . . .	2-16
CRT . . . . .	2-16
LCD . . . . .	2-16
Setting the HP-IB Address . . . . .	2-16
HP-IB Connectors and Cables . . . . .	2-18
Storing and Shipping . . . . .	2-20
Environment . . . . .	2-20
Packing the Instrument . . . . .	2-20
Returning an Instrument for Service . . . . .	2-20

### 3. Operation

HP/Agilent 8757D Firmware Capability . . . . .	3-1
<b>Local Operation</b>	
HP 8757D User's Guide (wire-o book) . . . . .	
1. Operating . . . . .	3
2. Transmission Measurements . . . . .	10
3. Reflection Measurements . . . . .	17
4. Limit Lines . . . . .	19
5. Alternate Sweep . . . . .	21
6. External Disk Save/Recall . . . . .	23
7. Special Functions . . . . .	25
A. AC versus DC Detection . . . . .	26
Index . . . . .	27
HP 8757D Operating Reference (wire-o book) . . . . .	
1. Front-Panel Features . . . . .	1-1
2. CHANNEL . . . . .	2-1
3. ENTRY Area . . . . .	3-1
4. FUNCTION Keys . . . . .	4-1
5. INSTRUMENT STATE . . . . .	5-1
6. Rear Panel Features . . . . .	6-1
A. Operator's Check . . . . .	A-1
B. Softkey Menu Structure Maps . . . . .	B-1
C. Performing an External Calibration . . . . .	C-1
D. Measurement Applications . . . . .	D-1
<b>Remote Operation</b>	
HP-IB Programming Notes . . . . .	1
HP 8757D Quick Reference Guide . . . . .	1
HP 8757D with HP 90000 Series 200/300 (BASIC) . . . . .	1
HP 8757D with HP Vectra (QuickBasic 4.5) . . . . .	1
HP 8757D with HP Vectra (QuickC 2.5) . . . . .	1
<b>In Case of Difficulty</b>	
Contents . . . . .	1
Manual Operation . . . . .	2
Line Power . . . . .	2
Error Codes . . . . .	2
System Operation . . . . .	3
General . . . . .	3
HP-IB Connections and Addresses . . . . .	3
Other Cable Connections . . . . .	4
Remote Operation . . . . .	4
Inaccurate Operation . . . . .	5
Calibration . . . . .	5
Modulation Characteristics . . . . .	5
Sweep Speed . . . . .	5
Calibrator Option 002 Only . . . . .	5
Miscellaneous Problems . . . . .	6
Alternate Sweep . . . . .	6
Number of Trace Points and Trace Memory . . . . .	7

Autozero of DC Detectors . . . . .	7
Save/Recall Registers . . . . .	7
System Interface On/Off . . . . .	8
Measurement-Memory-Memory . . . . .	9
Cursor Search . . . . .	9
On-Site Service . . . . .	9
Main Error Codes . . . . .	10
Power Calibration Error Messages . . . . .	13
Detector Error Messages (HP 85037A/B only . . . . .	14
On-Site Service - Calibration . . . . .	14

**Connector Care**

Principles of Microwave Connector Care—Quick Reference Card . . . . .	
---	--

**Glossary**





## General Information

---

This chapter provides information on the following topics:

- general safety considerations
- serial numbers
- analyzer description
- power calibrator option
- available options
- specifications
- operating characteristics
- manufacturer's radio interference declaration
- manufacturer's sound emission declaration
- manufacturer's ISO declaration
- ordering accessories and supplies

---

## General Safety Considerations

---

**Warning** No operator serviceable parts inside. Refer servicing to qualified personnel. To prevent electric shock, do not remove covers.

---

**Warning** To prevent electrical shock, disconnect the Agilent Technologies 8757D from mains before cleaning. Use a dry cloth or one slightly dampened with water to clean the external case parts. Do not attempt to clean internally.

---

**Warning** If this product is not used as specified, the protection provided by the equipment could be impaired. This product must be used in a normal condition (in which all means for protection are intact) only.

---

**Caution** Always use the three-prong AC power cord supplied with this product. Failure to ensure adequate earth grounding by not using this cord may cause product damage.

---

## Safety Symbols

### General

This product was designed and manufactured in accordance with international safety standards. Before you operate this analyzer, review the product and related documentation. Become familiar with safety markings and instructions.



Instruction manual symbol: the product will be marked with this symbol when it is necessary for the user to refer to the instruction manual (refer to Table of Contents).



Indicates hazardous voltages.



Indicates earth (ground) terminal.



The CE mark is the registered trademark of the European Community.



The CSA mark is a registered trademark of the Canadian Standards Association.

ISM1-A

This is a symbol of an Industrial Scientific and Medical Group 1, Class A product (CISPR 11, Clause4).



The “ON” symbol is used to mark the position of the analyzer’s line power switch.



The “STANDBY” symbol is used to mark the position of the analyzer’s power switch.

### 1-2 General Information



The AC symbol is used to indicate the required nature of the line module input power.

The C-Tick mark is a registered trademark of the Australian Spectrum Management Agency.

---

**Warning**      **The WARNING sign denotes a hazard. It calls attention to a procedure, which, if not correctly performed or adhered to, could result in personal injury. Do not proceed beyond a WARNING sign until the indicated conditions are fully understood and met.**

---

**Caution**      A **Caution** note denotes a hazard. It calls attention to a procedure, that, if not correctly performed or adhered to, could result in damage to or destruction of the product. Do not proceed beyond a **Caution** note until the indicated conditions are fully understood and met.

---

### **Safety Earth Ground**

This is a Safety Class I product (provided with a protective earthing terminal). An uninterruptible safety earth ground must be provided from the main power source to the product input wiring terminals, power, cord, or supplied power cord set. Whenever it is likely that the protection has been impaired, the product must be made inoperative and secured against any unintended operation.

### **Before Applying Power**

Verify that the product is configured to match the available main power source. Refer to the input power configuration instructions provided in this manual.

If this product is to be used with an autotransformer make sure the common terminal is connected to the neutral (grounded) side of the main supply.

### **Servicing**

Any servicing, adjustment, maintenance, or repair of this product must be performed only by qualified personnel. Capacitors inside this product may still be charged even when disconnected from their power source.

To avoid a fire hazard, replacement fuses must have the required current rating and be of the type specified in this manual.

## Preface

This manual applies directly to all HP/Agilent 8757D network analyzers. See the serial number plate (Figure 1-1) attached to the analyzer back panel. The first four digits followed by a letter are the serial number prefix. The last five digits are the sequential suffix, which are unique to each instrument.

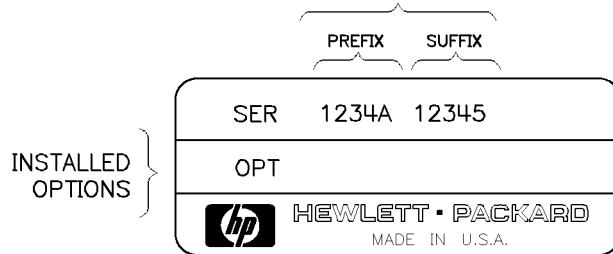

**Figure 1-1. Typical Serial Number Label**

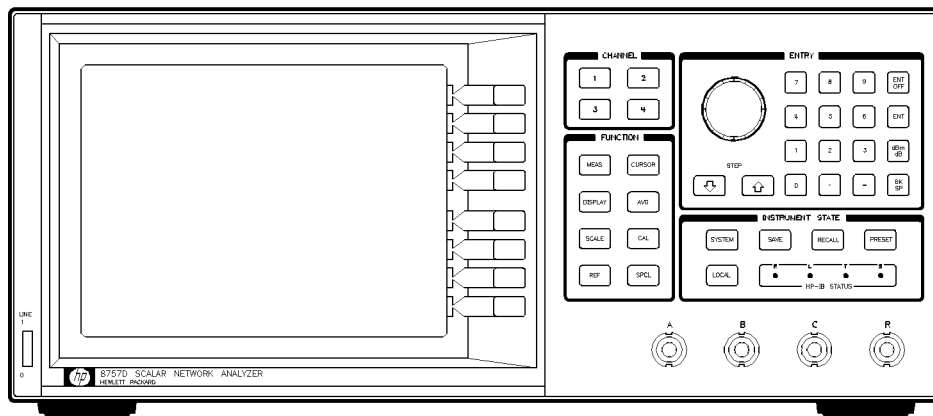

HP 8757D OPTION 001 SCALAR NETWORK ANALYZER

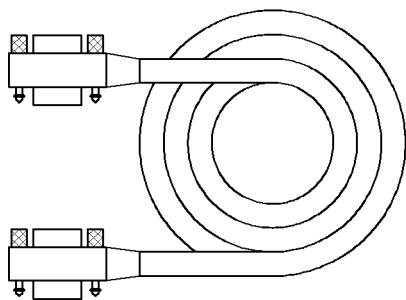

HP-IB CABLE

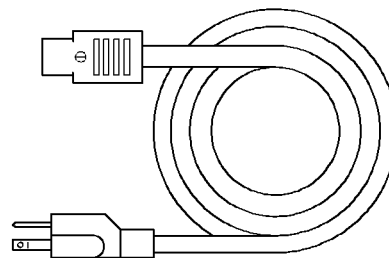

POWER CABLE \*

\* Power cable/plug supplied depends on country of destination.

Figure 1-2. HP 8757D Scalar Network Analyzer and Accessories Supplied

---

## The HP 8757D Analyzer

The HP 8757D (Figure 1-2) is a microprocessor-based receiver capable of making scalar (magnitude only) reflection and transmission measurements. The external detectors used determine the frequency range. The raster display provides high resolution for viewing measurements.

---

**Note** The original HP 8757D incorporated a cathode ray tube (CRT) based display. The current design incorporates a liquid crystal display (LCD) based display. In this manual, references to either CRT or LCD apply to both display designs unless noted otherwise.

---

### CRT/LCD Attributes

The CRT/LCD displays attributes (such as the grid, measurement traces for each channel, and labels) in factory-defined colors. You can adjust the hue, saturation and intensity of each of these attributes.

### Displays

The analyzer can simultaneously drive both the internal display and one external monitor (color or monochrome, if compatible with the analyzer's scan rate and video levels).

### Peripherals

You can use the analyzer to control external printers, plotters, and sources through the system interface. A printer and plotter buffer speeds measurements by returning control to the analyzer while data prints.

### Calibration Data and Instrument States

You can store and recall instrument states and calibration data to and from external disks.

### Measurement Channels

Four independent but identical measurement channels allow simultaneous measurements and viewing of measurement parameters. The detector inputs (A, B, C, and R) accept AC or DC detected signals from detectors or bridges.

### Local and Remote Operation

You can operate the analyzer either locally, using the front panel controls and menu selections, or remotely over the HP-IB. You can also generate on-screen graphics (see "Remote Operation").

## Options Available

- Option 001 adds a fourth detector input (C).
- Option 002 adds the power calibrator.
- Option 001 and 002 adds *both* the fourth detector input and the power calibrator. (See the front panel options table on the following page and the descriptions below it for more detailed information on these options.)

### HP 8757 FRONT PANEL OPTIONS

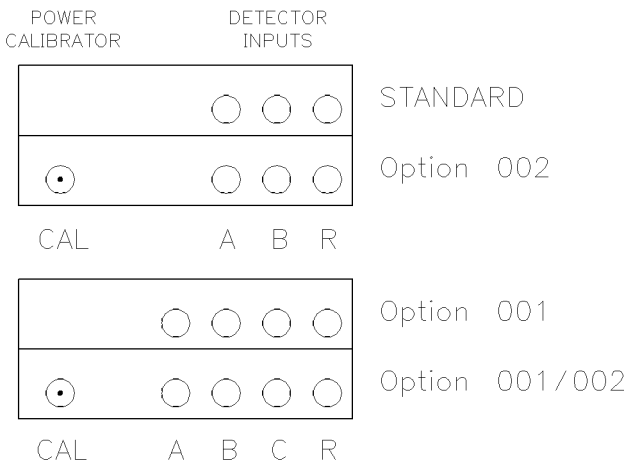

**Figure 1-3.**

#### Option 001, Fourth Detector Input

This option supplies four front-panel detector inputs (A, B, C, and R).

#### Option 002, Internal Power Calibrator

This option supplies three front panel detector inputs (A,B,and R) and adds an internal power calibrator. The power can be precisely controlled in 1 dB increments from +20 to -50 dBm.

#### Option 908, Rack Mount Without Handles

This option supplies a rack mount kit containing a pair of flanges and the necessary hardware to mount the analyzer (with handles *detached*) in an equipment rack that has 482.6 mm (19 in) horizontal spacing. See chapter 2 for installation instructions.

#### Option 913, Rack Mount With Handles

This option supplies a rack mount kit containing a pair of flanges and the necessary hardware to mount the analyzer (with handles *attached*) in an equipment rack that has 482.6 mm (19 in) horizontal spacing. See chapter 2 for installation instructions.

**Option W30, Extended Service**

This option (identified on the serial number tag) adds two additional years of return-to-HP hardware support following the first year of warranty. You can order this option only at time-of-purchase.

**Option W32, Three-Year Calibration**

This option (identified on the serial number tag) provides a three-year return-to-HP calibration service. You can order this option only at time-of-purchase.

**Option 1BN, MIL-STD 45662A Calibration**

This option provides an instrument calibration and a certificate of calibration in full compliance with MIL-STD 45662A.

**Option 1BP, MIL-STD 45662A Calibration with Data**

This option provides an instrument calibration, a certificate of calibration, and test data in full compliance with MIL-STD 45662A.



---

## **Specifications, General Requirements, and Operating Characteristics**

### **Specifications**

Specifications (listed in Table 1-1) are the performance standards or limits against which the instrument is tested. Specifications apply from +20°C to +30°C (unless otherwise noted), and only after the instrument's temperature stabilizes after one hour of continuous operation. Unless otherwise noted, corrected limits are given when specifications are subject to optimization with error-correction routines.

### **General Requirements**

General requirements (listed in Table 1-2) define specifications required of the source for proper analyzer operation.

### **Operating Characteristics**

Operating characteristics (listed in Table 1-3) are non-warranted parameters. They are not specifications, but are typical performance parameters that most units meet from +20°C to +30°C.

**Table 1-1. HP 8757D Specifications<sup>1</sup> (1 of 2)**

**Function:** Four independent display channels process signals from the HP 85025, 85026, 11664, or 85037 detectors and the HP 85020 or 85027 bridges. The analyzer displays the data logarithmically, in single input or ratio mode, with respect to frequency, on the internal CRT/LCD. Three detector inputs (A, B, and R) accept AC or DC detected signals from detectors or bridges.

Option 001 has four detector inputs (A, B, C, and R).

**Modulator Drive:** The analyzer modulator drive output provides the circuitry to drive the HP 8340 and 8341 synthesized sweepers and the HP 11665B modulator. You can turn modulator drive on and off via either the front panel or HP-IB. In the OFF state, the modulator drive signal turns the HP 11665B fully on for minimum insertion loss. The 8360 and 8370 synthesized sweepers have the capability of modulating signals, so an external modulator such as the 11665B is not necessary when using the 8360/8370 series.

**Marker Accuracy:** The marker frequency accuracy is 0.1 PPM of the marker frequency plus the source marker frequency accuracy.

**Frequency:** 27.778 kHz  $\pm$ 12 Hz  
**Symmetry:** 50%  $\pm$ 1%

**Dynamic Range, Dynamic Accuracy, Absolute Power Accuracy:** These system specifications are dependent on the detector used. The following examples show both the HP 85037A/B and the HP 11664A/E detectors. (For HP 85025 and HP 85026 specifications, refer to their manuals.)

**Dynamic Range<sup>2</sup>**

HP 85037A/B  
 AC Mode: +20 to -55 dBm  
 DC Mode: +20 to -50 dBm

HP 11664A/E  
 AC Mode: +16 to -60 dBm

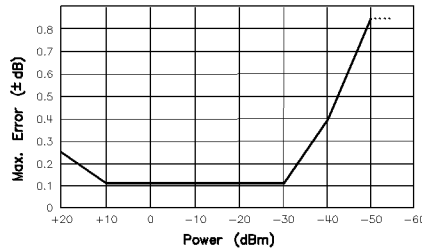

Dynamic Accuracy - AC/DC MODE  
 Absolute Accuracy - DC MODE  
 (D.C. MODE to -50dBm only)

**HP 85037A/B**

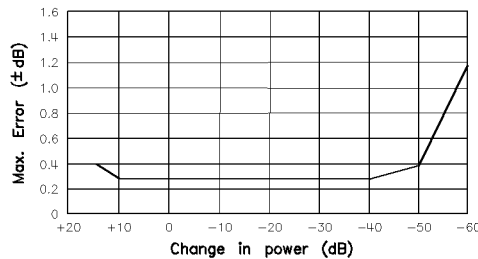

Note: For  $\leq 20$ dB change of power within +10 to -40dBm the specifications for the HP8757D with the HP11664A/E is  $\pm (0.1\text{dB} + 0.01\text{dB/dBm})$ .

**HP 11664A/E**

<sup>1</sup>All specification apply at 25°  $\pm$ 5°C, unless otherwise noted.

<sup>2</sup>Using an HP 85037A/B Detector.

## HP 8757D Specifications<sup>1</sup> (2 of 2)

### Power Calibrator (Option 002)

The internal power calibrator option (Option 002) provides a 50 MHz reference standard for characterizing the absolute power accuracy and dynamic power accuracy of HP 85037 Series precision detectors.

**Frequency:** 50 MHz  $\pm$ 0.1 MHz

**Output Power (DC mode):**

Range: +20 to -50 dBm  
Accuracy at 0 dBm:  $\pm$ 0.05 dB

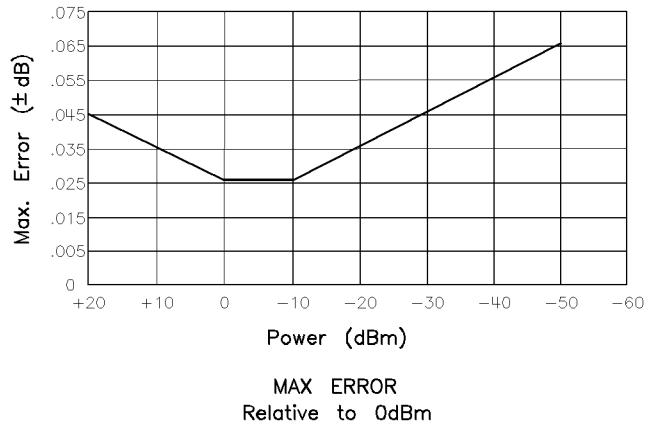

SWR:  $\leq$ 1.05 typical

**Modes of Operation:**

DC Mode (unmodulated)

AC Mode:

Modulation Frequency: 27.778  $\pm$ 0.012 kHz

On/Off Ratio:  $\geq$ 40 dB typical

Symmetry: 50  $\pm$  1% typical

**Connector:** Type-N(f)

**Accessories Included:**

Adapter: Type-N(m) to 3.5 mm(f)

<sup>1</sup>All specification apply at 25°  $\pm$ 5°C, unless otherwise noted.

**Table 1-2. HP 8757D General Requirements**

General requirements define specifications required of the source for proper analyzer operation.

**Sweep Time:** Minimum sweep time and maximum number of displayed CRT/LCD traces depend on the horizontal resolution (number of points):

Number of Points	Minimum Sweep Time (ms) <sup>1</sup>			
	1 Input	2 Inputs	3 Inputs	4 Inputs
101	40	40	40	40
201	40	40	52	68
401	40	72	104	136
801	80	144	208	272
1601	160	288	NA	NA

**Modulation** (for use with HP 85025, 85026, 11664, 85037 detectors and HP 85020 or 85027 bridges in AC mode):

Square-wave amplitude modulation.  
 Frequency: 27.778 kHz ±20 Hz.  
 ≥30 dB on/off ratio.  
 45% to 55% symmetry.

**Sweep Voltage** (Sweep In): Horizontal sweep voltage (0 to 10 V) or a pulse signal (0 to 10 V) from an HP 83750 Series source provided to the analyzer's SWEEP IN 0—10V rear-panel input. You can use other sweep voltages by using the analyzer's non-standard sweep mode.

**Marker and Marker Blanking** (Poz Z Blank): Blanking and marker signals provided to the analyzer's POS Z BLANK rear-panel input. HP 8350, HP 8340 and 8341, and HP 8360 Series sources provide five available markers, but the HP 83750 Series source provides ten available markers.

Voltage Levels (Typical)	
Blanked	+5 V
Unblanked	0 V
Marker	-4 V
Active Marker	-8 V

<sup>1</sup>Log magnitude format.

**Table 1-3. Operating Characteristics<sup>1</sup> (1 of 4)**

<b>Display</b>			
<b>Display Modes:</b> All analyzer channels can display any detector input, or any ratio combination of detector inputs. The CRT/LCD can display data in one of the following modes.			
Log Magnitude:			
dBm:	Single channel power measurement.		
dB:	Relative power measurement (ratio or relative to trace memory).		
SWR:	Relative measurements.		
AUX:	The rear-panel BNC input ADC IN can be measured and displayed in volts (−10 to +10V). Typical maximum error is 60 mV.		
<b>Display Mode</b>	<b>Scale Resolution</b>	<b>Display Range</b>	<b>Vertical Resolution</b>
dBm	0.1 to 20 dB/div	−80 to −130 dBm <sup>2</sup>	0.003 dB <sup>3</sup>
dB (ratio)	0.1 to 20 dB/div	−150 to +150 dBm <sup>4</sup>	0.006 dB <sup>3</sup>
Normalized Ratio	0.1 to 20 dB/div	−180 to +180 dB	0.01 dB
SWR	0.02 to 10 units/div	1.0 to 37.0	0.01 at 1 0.1 at 10 0.27 at 30
AUX	0.025 to 5V/div	−10 to +10V	0.001 V
<b>Color Settings:</b> Up to 8 operator-selected colors for CRT/LCD attributes (such as the grid, measurement traces, and labels).			

<sup>1</sup>The values in this table are *not* specifications, but typical, non-warranted performance parameters.

<sup>2</sup>Maximum 90 dB range per trace.

<sup>3</sup>0.01 dB for display cursor.

<sup>4</sup>Maximum 180 dB range per trace.

**Table 1-3. Operating Characteristics<sup>1</sup> (2 of 4)**

Display(cont'd)	
<b>Horizontal Resolution:</b>	
<b>Number of Traces</b>	<b>Number of Points</b>
1	101, 201, 401, 801, 1601
2	101, 201, 401, 801
3, 4	101, 201, 401
<b>Averaging:</b> 2, 4, 8, 16, 32, 64, 128, or 256 successive traces.	
<b>Smoothing:</b> Provides a linear moving average of adjacent data points. The smoothing aperture defines the trace width (number of data points) averaged, and ranges from 0.1% to 20% of the trace width.	
<b>Normalization:</b> Traces are stored and normalized with the highest resolution, independent of display scale/division or offset.	
Calibration data is interpolated when you decrease the frequency span with adaptive normalization engaged.	
<b>Limit Lines:</b> Any limit combination of flat or sloped lines, or single points (up to 12 segments) can be displayed on channels 1 and 2. You can store limit lines in save/recall registers 1 through 4.	
<b>Graticules:</b>	
8 vertical x 10 horizontal divisions.	
1 division $\approx$ 11 mm.	

<sup>1</sup>The values in this table are *not* specifications, but typical, non-warranted performance parameters.

**Table 1-3. Operating Characteristics<sup>1</sup> (3 of 4)**

<b>LCD/CRT and Graphics</b>											
<p><b>CRT Scan Rate:</b> Raster scan with 60 Hz vertical refresh rate, and 25.5 kHz horizontal scan rate.  <b>CRT Graphics Resolution:</b> 1024 horizontal x 400 vertical pixels.</p> <p><b>LCD Scan Rate:</b> Raster scan with 59.83 Hz vertical refresh rate and 31.41 kHz horizontal scan rate.  <b>LCD Graphics Resolution:</b> 640 horizontal x 480 vertical pixels.</p>											
<b>Rear Panel Connectors</b>											
<p><b>ADC IN:</b> An auxiliary voltage input (−10 to +10V) that can be displayed (in volts) on any channel.</p> <p><b>Control 1 and 2:</b> Provide digital output signals (TTL open-collector) to drive peripheral equipment in an HP-IB controlled system.</p> <p><b>DAC Out:</b> Used in troubleshooting.</p> <p><b>Modulator Drive:</b> Provides the drive for HP 8340/8341 synthesized sweepers and the HP 11665B modulator. You can turn modulator drive on/off at the front panel or by HP-IB.</p> <p><b>Pos Z Blank Input:</b></p> <table style="margin-left: auto; margin-right: auto;"> <thead> <tr> <th></th> <th style="text-align: center;"><b>Voltage Levels</b></th> </tr> </thead> <tbody> <tr> <td style="padding-left: 2em;">Blanked:</td> <td style="text-align: center;">+5 V</td> </tr> <tr> <td style="padding-left: 2em;">Unblanked:</td> <td style="text-align: center;">0 V</td> </tr> <tr> <td style="padding-left: 2em;">Marker:</td> <td style="text-align: center;">−4 V</td> </tr> <tr> <td style="padding-left: 2em;">Active Marker:</td> <td style="text-align: center;">−8 V</td> </tr> </tbody> </table> <p><b>Stop Sweep:</b> Used with HP 8350 sweep oscillators and HP 8340, 8341, or 8360 synthesized sweepers (when controlled by the HP 8757 system interface) to stop the sweep at band crossings and at the end of sweep.</p> <p><b>Sweep In:</b> Accepts the horizontal sweep voltage (usually provided by the source).</p> <p><b>CRT Video Output:</b> Three BNC connectors used to drive external monitors with the following characteristics:</p> <ul style="list-style-type: none"> <li>75Ω input impedance.</li> <li>R, G, B, with sync on green.</li> <li>60 Hz vertical refresh rate.</li> <li>25.5 kHz horizontal scan rate.</li> <li>1 Vp-p (0.7 V = white; 0 V = black; −0.3 V = sync).</li> </ul> <p><b>LCD Video Output:</b> VGA compatible.</p>			<b>Voltage Levels</b>	Blanked:	+5 V	Unblanked:	0 V	Marker:	−4 V	Active Marker:	−8 V
	<b>Voltage Levels</b>										
Blanked:	+5 V										
Unblanked:	0 V										
Marker:	−4 V										
Active Marker:	−8 V										
<b>Internal Save/Recall Registers</b>											
<p><b>General Capability:</b> Separate front panel states may be saved in registers 1 through 9. If an appropriate source is connected to the 8757D system interface, the front panel state of the source is included in the saved state.</p> <p><b>Memory Trace and Limit Lines:</b> For channels 1 and 2, the states saved in registers 1 through 4 also include the appropriate trace and limit line data. (Registers 5 through 9 only store front panel states.)</p>											

<sup>1</sup>The values in this table are *not* specifications, but typical, non-warranted performance parameters.

**Table 1-3. Operating Characteristics<sup>1</sup> (4 of 4)**

<b>HP-IB</b>			
<b>Interface:</b> HP-IB operates according to IEEE 488-1978 and IEC-625 interface standards. Note that the HP-IB interface does not support the IEEE 488.2 standard.			
<b>Interface Function Codes:</b> SH1, AH1, T6, TE0, L4, LE0, SR1, RL1, PP0, DC1, DT0, C0, E1.			
<b>Transfer Formats:</b> You may transfer data either as ASCII characters, or as 16-bit integers (most significant byte first). You may take readings at a single point, or transfer an entire trace at once.			
<b>Transfer Speed</b> (includes command to initiate output):			
	<b>Format</b>	<b># Points</b>	<b>ms (typical)</b>
	ASCII	401	500
	ASCII	1	10
	Binary	401	30
	Binary	1	7
<b>Programmable Functions:</b> Except for power on/off, all front panel functions are programmable. The analyzer is compatible with all appropriate HP 8757A/C/E programming codes.			
<b>Interrupts:</b> The following conditions generate HP-IB service interrupts (SRQs):			
	Front panel key pressed		Illegal command
	Instrument self-test error		Limit test fails
	Operation (sweep or plot) completes		
<b>System Interface</b>			
The 8757 system interface is a dedicated HP-IB port used exclusively by the analyzer to control and extract information from a swept source, digital plotter, printer, or other device.			
<b>General</b>			
<b>Temperature Range:</b>	Operating:	0° to +55°C (+32° to 131°F)	
	Storage:	-40° to +70°C (-40° to +158°F)	
<b>Humidity:</b> Maximum relative humidity 80% for temperatures up to 31 °C decreasing linearly to 50% relative humidity at 40 °C (unless specified otherwise).			
<b>Altitude:</b> 3000 meters			
<b>Power Requirements:</b> 48 to 66 Hz, 100/120/220/240 V ±10%, typically 155 VA.			
<b>Dimensions:</b> 178 x 425 x 445 mm (7.0 x 16.75 x 17.5 in).			
<b>Weight:</b>	Net:	17 kg (38 lb)	
	Shipping:	25 kg (55 lb)	

<sup>1</sup> The values in this table are *not* specifications, but typical, non-warranted performance parameters.



---

**Caution**

This product is designed for use in INSTALLATION CATEGORY II AND POLLUTION DEGREE 2, per IEC 61010-1 and 664 respectively.

---

---

**Manufacturer's Declarations**

---

**RADIO FREQUENCY INTERFERENCE**

---

**Note**

This is to certify that this product meets the radio frequency interference requirements of Directive FTZ 1046/1984. The German Bundespost has been notified that this equipment was put into circulation and has been granted the right to check the product type for compliance with these requirements.

Note: If test and measurement equipment is operated with unshielded cables and/or used for measurements on open set-ups, the user must ensure that under these operating conditions, the radio frequency interference limits are met at the border of his premises.

Model HP/Agilent 8757D

---

**Note**

Hiermit wird bescheinigt, dass dieses Gerat/System in Ubereinstimmung mit den Bestimmungen von Postverfugung 1046/84 funkentstort ist.

Der Deutschen Bundespost wurde das Inverkehrbringen dieses Gerates/Systems angezeigt und die Berechtigung zur Uberprufung der Serie auf Einhaltung der Bestimmungen eingeräumt.

Zustzinformation fur Mess-und Testgerate:

Werden Mess- und Testgerate mit ungeschirmten Kabeln und/oder in offenen Messaufbauten verwendet, so ist vom Betreiber sicherzustellen, dass die Funk-Entstorb Bestimmungen unter Betriebsbedingungen an seiner Grundstücksgrenze eingehalten werden.

---

## SOUND EMISSION

---

**Note**

This statement is provided to comply with the requirements of the German Sound Emission Directive, from 18 January 1991.

This product has a sound pressure emission (at the operator position) <70 dB.

- Sound Pressure  $L_p$  <70 dB (A).
- At Operator Position.
- Normal Operation.
- According to ISO 7779 (Type Test).

Model HP/Agilent 8757D

---

**Note**

Herstellerbescheinigung

Diese Information steht im Zusammenhang mit den Anforderungen der Maschinenlarminformationsverordnung vom 18 Januar 1991.

- Schalldruckpegel  $L_p$  <70 dB(A).
  - Am Arbeitsplatz.
  - Normaler Betrieb.
  - Nach DIN 45635 T. 19 (Typprüfung).
-

# DECLARATION OF CONFORMITY

According to ISO/IEC Guide 22 and CEN/CENELEC EN 45014

**Manufacturer's Name:** Agilent Technologies, Inc.

**Manufacturer's Address:** 1400 Fountaingrove Parkway  
Santa Rosa, CA 95403-1799  
USA

Declares that the product

**Product Name:** Network Analyzer

**Model Number:** 8757D

**Product Options:** This declaration covers all options of the above product.

Conforms to the following product specifications:

EMC: IEC 61326-1:1997+A1:1998 / EN 61326-1:1997+A1:1998

<u>Standard</u>	<u>Limit</u>
CISPR 11:1990 / EN 55011-1991	Group 1, Class A
IEC 61000-4-2:1995+A1998 / EN 61000-4-2:1995	4 kV CD, 8 kV AD
IEC 61000-4-3:1995 / EN 61000-4-3:1995	3 V/m, 80 - 1000 MHz
IEC 61000-4-4:1995 / EN 61000-4-4:1995	0.5 kV sig., 1 kV power
IEC 61000-4-5:1995 / EN 61000-4-5:1996	0.5 kV L-L, 1 kV L-G
IEC 61000-4-6:1996 / EN 61000-4-6:1998	3 V, 0.15 - 80 MHz
IEC 61000-4-11:1994 / EN 61000-4-11:1998	1 cycle, 100%

Safety: IEC 61010-1:1990 + A1:1992 + A2:1995 / EN 61010-1:1993 +A2:1995  
CAN/CSA-C22.2 No. 1010.1-92

## Supplementary Information:

The product herewith complies with the requirements of the Low Voltage Directive 73/23/EEC and the EMC Directive 89/336/EEC and carries the CE-marking accordingly.



Santa Rosa, CA, USA 12 Oct. 2000

Greg Pfeiffer/Quality Engineering Manager

For further information, please contact your local Agilent Technologies sales office, agent or distributor.

---

## **Accessories and Supplies**

See Figure 2-2, “Example of a Static-Safe Workstation,” and Table 1-4 for a list available parts. To order a listed item, provide the part number and the quantity required; send the order to the nearest Agilent Technologies sales and service office, listed at the back of this chapter.

**Table 1-4. Replaceable Parts for the HP/Agilent 8757D**

Description	HP/Agilent Part Number
<b>Documentation</b>	
Manual Set (includes 08757-90109 and 08757-90110)	08757-90107
Operating Manual (includes programming guides)	08757-90109
Programming Guides:	
HP 9000 Series 200/300	08757-90116
HP Vectra Microsoft Quick Basic 4.5	08757-90117
HP Vectra Microsoft C 2.5	08757-90118
Quick Reference Guide	08757-90130
Service Manual	08757-90110
Connector Care	08510-90064
<b>Other</b>	
Touch-up Paint (cobblestone gray)	6010-1140
Adapter <sup>1</sup> (type-N male to 3.5 mm female)	08485-60005
HP-IB Cable	10833A
<b>Fuses</b>	
2.5 A 250 V NTD FE UL	2110-0083
1.5 A 250 V NTD FE UL	2110-0043
<b>Rack Mount Handles</b>	
Front Handles (standard)	5062-3990
Rack Mounting without Handles (Option 908)	5062-3978
Rack Mounting with Handles (Option 913)	5062-4072
<b>ESD Supplies</b>	
Conductive Table Mat with 15 ft Ground Wire	9300-0797
Wrist Strap to Table Mat Grounding Cord	9300-0980
Grounding Wrist Strap	9300-1367
ESD Heal Strap (reusable 6 to 12 months)	9300-1126
<b>Cleaning Supplies</b>	
Compressed Air (235 ml)	8500-6659
Cleaning Swabs (100)	9301-1243
Isopropyl Alcohol (8 oz)	8500-0559
Isopropyl Alcohol (30 ml)	8500-5344

<sup>1</sup> Part of Option 002.

**Table 1-5. Agilent Technologies Sales and Service Offices**

<b>UNITED STATES</b>		
<p><b>Instrument Support Center</b>                      Agilent Technologies                      (800) 403-0801</p>		
<b>EUROPEAN FIELD OPERATIONS</b>		
<p><b>Headquarters</b>                      Agilent Technologies S.A.                      150, Route du Nant-d'Avril                      1217 Meyrin 2/Geneva                      Switzerland                      (41 22) 780.8111</p>	<p><b>France</b>                      Agilent Technologies France                      1 Avenue Du Canada                      Zone D'Activite De Courtaboeuf                      F-91947 Les Ulis Cedex                      France                      (33 1) 69 82 60 60</p>	<p><b>Germany</b>                      Agilent Technologies GmbH                      Agilent Technologies Strasse                      61352 Bad Homburg v.d.H                      Germany                      (49 6172) 16-0</p>
<p><b>Great Britain</b>                      Agilent Technologies Ltd.                      Eskdale Road, Winnersh Triangle                      Wokingham, Berkshire RG41 5DZ                      England                      (44 118) 9696622</p>		
<b>INTERCON FIELD OPERATIONS</b>		
<p><b>Headquarters</b>                      Agilent Technologies Company                      3495 Deer Creek Road                      Palo Alto, California, USA                      94304-1316                      (415) 857-5027</p>	<p><b>Australia</b>                      Agilent Technologies Australia Ltd.                      31-41 Joseph Street                      Blackburn, Victoria 3130                      (61 3) 895-2895</p>	<p><b>Canada</b>                      Agilent Technologies (Canada) Ltd.                      17500 South Service Road                      Trans-Canada Highway                      Kirkland, Quebec H9J 2X8                      Canada                      (514) 697-4232</p>
<p><b>China</b>                      China Agilent Technologies                      38 Bei San Huan X1 Road                      Shuang Yu Shu                      Hai Dian District                      Beijing, China                      (86 1) 256-6888</p>	<p><b>Japan</b>                      Agilent Technologies Japan, Ltd.                      9-1 Takakura-Cho, Hachioji                      Tokyo 192, Japan                      (81 426) 60-2111</p>	<p><b>Singapore</b>                      Agilent Technologies Singapore (Pte.) Ltd.                      150 Beach Road                      #29-00 Gateway West                      Singapore 0718                      (65) 291-9088</p>
<p><b>Taiwan</b>                      Agilent Technologies Taiwan                      8th Floor, H-P Building                      337 Fu Hsing North Road                      Taipei, Taiwan                      (886 2) 712-0404</p>		

## Installation

---

This chapter provides information on the following topics:

- initial inspection
- instrument serial numbers
- environmental requirements
- electrostatic discharge hazards and precautions
- line voltage selector switch
- fuse inspection
- power cable inspection

---

## Introduction

This section provides installation instructions for your HP/Agilent 8757D scalar network analyzer. This section also includes information about initial inspection, damage claims, preparation for using the analyzer, packaging, storage and shipment.

---

## Initial Inspection

Inspect the shipping container for damage. If the shipping container or cushioning material is damaged, keep it until you have verified that the contents are complete and you have tested the analyzer mechanically and electrically.

If the shipment is incomplete or if the analyzer does not pass the operator's check (see chapter 3) notify the nearest Agilent office. If the shipping container is damaged or the cushioning material shows signs of stress, notify the carrier. Keep the shipping materials for the carrier's inspection. The Agilent office will arrange for repair or replacement without waiting for a claim settlement.

If the shipping container and cushioning material are in good condition, retain them for possible future use. You may wish to ship the analyzer to another location or to return it to Agilent Technologies for service. Instructions for repackaging and shipping the instrument are located at the end of this chapter.

## Shipment Contents

A complete shipment consists of one box (see chapter 1 for part numbers).

- The box will contain one each of the following:
  - HP/Agilent 8757D scalar network analyzer
  - HP-IB cable
  - power cable
  - type-N to 3.5 mm adapter (Option 002 only)
  - front handles
  - operating manual
  - service manual

## Serial Numbers

Agilent Technologies makes frequent improvements to its products to enhance their performance, usability, or reliability, and to control costs. Agilent service personnel have access to records of design changes to each type of equipment, based on the equipment's serial number. If you contact Agilent about your analyzer, have the complete serial number available to make sure that you receive the most complete and accurate information possible.

A serial number label is attached to the rear panel of the analyzer. A typical serial number label is shown in Figure 2-1. The first four digits followed by a letter comprise the serial number prefix; the last five digits are the sequential suffix, unique to each instrument.



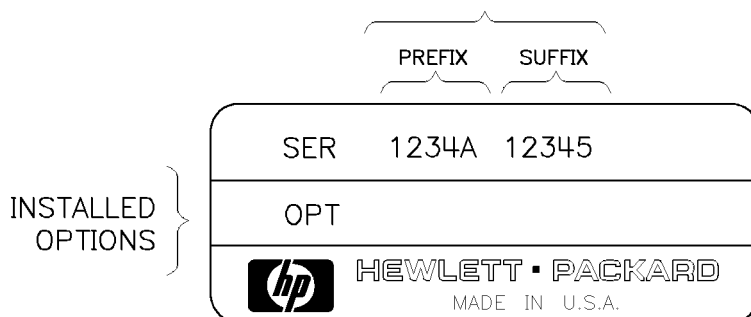

**Figure 2-1. Typical Serial Number Label**

---

## Operating Environment

---

**Caution**      **VENTILATION REQUIREMENTS:** When installing the product in a cabinet, the convection into and out of the product must not be restricted. The ambient temperature (outside the cabinet) must be less than the maximum operating temperature of the product by 4 °C for every 100 watts dissipated in the cabinet. If the total power dissipated in the cabinet is greater than 800 watts, then forced convection must be used.

---

To meet the specifications listed in chapter 1, you must operate this instrument within the following limits:

**Temperature**    0 to +55°C (+32 to 131°F)

**Altitude**        ≤ 4572 metres (15,000 feet)

**Humidity**        5 to 95% at +25 to +40° C (+77 to 104°F)

Protect the analyzer from temperature extremes which can cause internal condensation.

**Cooling**         Leave 10 cm (4 in) of room at the rear of the cabinet and 7.6 cm (3 in) at the sides of the cabinet. In bench stacking, the plastic feet provide adequate clearance for the top and bottom surfaces. In rack mounting, filler strips provide the clearance.

The rear-mounted fan moves air into the instrument and out through the sides. Clean the fan regularly.

## Electrostatic Discharge

Because electrostatic discharge (ESD) can damage or destroy electronic components, perform all work on assemblies consisting of electronic components at a static-safe work station.

### Static-Safe Accessories

See chapter 1 “General Information” for static-safe accessories available from Agilent Technologies.

Figure 2-2 is an example of a static-safe work station using two types of ESD protection that can be used either together or separately:

1. A conductive table mat and wrist-strap combination.
2. A conductive floor mat and heel-strap combination.

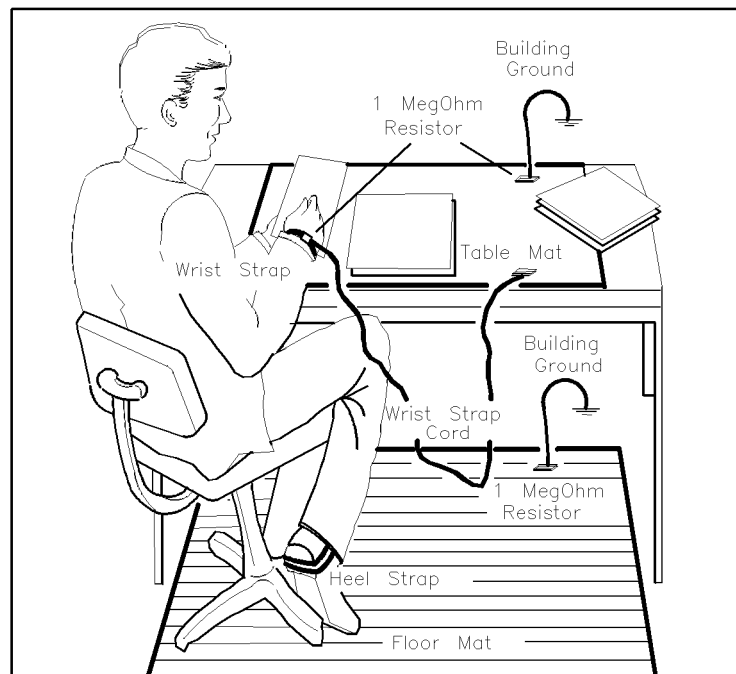

**Figure 2-2. Example of a Static-Safe Work Station**

### Reducing Damage Caused by ESD

The following can help reduce ESD damage that occurs during testing and servicing operations:

- Before you connect a coaxial cable to an analyzer connector for the first time each day, momentarily ground the cable center and outer conductors.
- Ground yourself with a resistor-isolated wrist strap before touching the center pin of *any* connector, and before removing *any* assembly from the instrument.
- To prevent a buildup of static charge, ensure that all instruments are properly earth-grounded.

---

## Power Requirements

**Table 2-1. HP/Agilent 8757D Power Requirements**

Characteristic	Requirement
Input Voltage	100, 120, 220, or 240 V ( $\pm 10\%$ )
Frequency	48 to 66 Hz
Power	155 VA (max)

---

### Cautions

Before switching on this instrument, make sure

- the line voltage selector switch is set to the voltage of the mains supply
  - the correct fuse is installed
  - the supply voltage is in the specified range
- 

### Checking the Line Voltage and Fuse

Both the voltage selection card and the fuse are located in the AC power module on the rear panel of the analyzer (see Figure 2-3). For continued protection against fire hazard, replace line fuse only with the same type and ratings. The use of other fuses or materials is prohibited. To select the line voltage and fuse (see chapter 1 for fuse part numbers):

1. Measure the AC line voltage.
2. Using the values in Table 2-2, follow the instructions in Figure 2-3.

**Table 2-2. Line Voltage and Fuse Selection**

Measured AC Line Voltage (V)	Voltage Selection Card Position	Fuse (A)
90 to 110	100	2.5
108 to 132	120	2.5
198 to 242	220	1.5
216 to 264	240	1.5

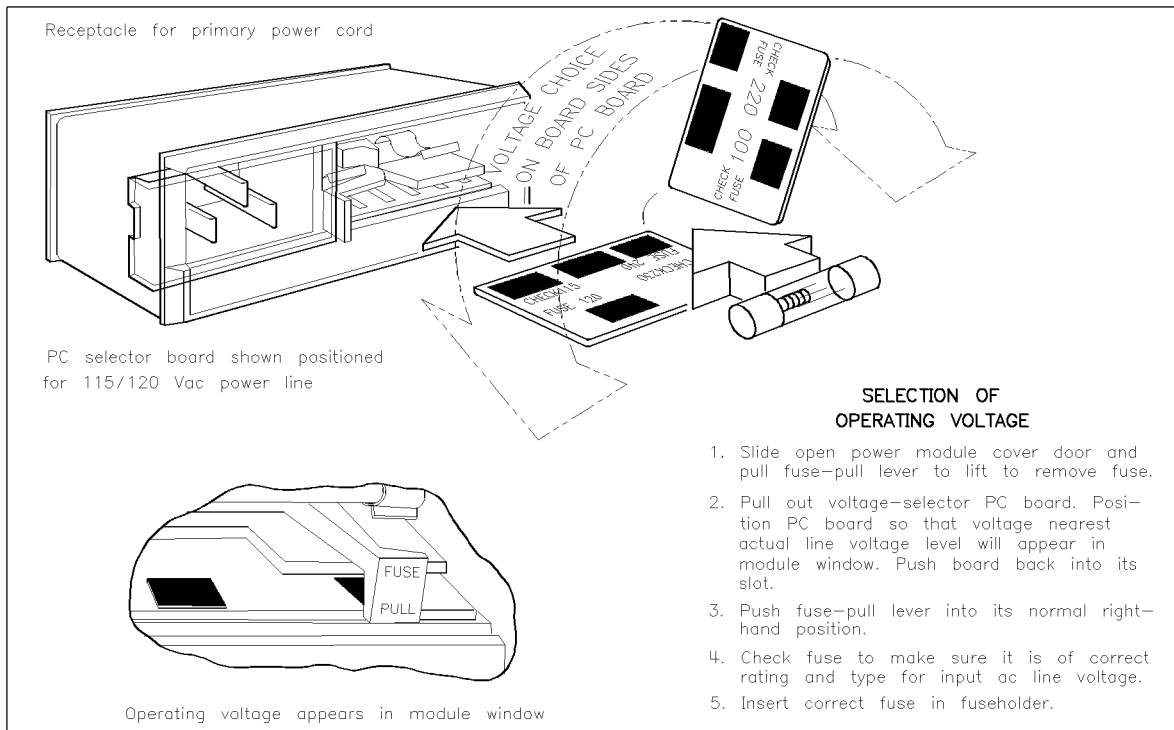

**Figure 2-3. Setting the Voltage Selector Switch and Checking the Fuse**

## Checking the Power Cable

The analyzer is shipped with a three-wire power cable (appropriate for its original destination), in accordance with international safety standards. When connected to an appropriate power line outlet, this cable grounds the analyzer chassis.

### Warning

**This is a Safety Class 1 Product (provided with a protective earthing ground incorporated in the power cord). The mains plug shall only be inserted in a socket outlet provided with a protective earth contact. Any interruption of the protective conductor inside or outside of the product is likely to make the product dangerous. Intentional interruption is prohibited. (IEC 348 clauses 17.3.3 c) & 17.3.4)**

Install the instrument so that the ON/OFF switch is readily identifiable and is easily reached by the operator. The ON/OFF switch or the detachable power cord is the instrument disconnecting device. It disconnects the mains circuits from the mains supply before other parts of the instrument. Alternatively, an externally installed switch or circuit breaker (which is readily identifiable and is easily reached by the operator) may be used as a disconnecting device.

---

## Equipment Required But Not Supplied

To make measurements with a standard analyzer, you must have a swept RF or microwave source and from one to three detectors or directional bridges (four with an Option 001).

### AC Detection

AC detection measurements require square wave modulation capability at 27.778 kHz.

### Firmware Compatibility

Table 2-3 lists the sweeper firmware revisions required for complete compatibility with the HP/Agilent 8757D.

**Table 2-3. Firmware Revisions**

HP/Agilent Sweeper	Firmware Revision
8350B	$\geq 6$
83522A	$\geq 3$
83525A/B	$\geq 3$
83540A/B	$\geq 3$
83545A	$\geq 3$
83550A	$\geq 6$
83570A	$\geq 3$
83572A/B	$\geq 6$
83590A	$\geq 6$
83592A/B/C	$\geq 6$
83594A	$\geq 6$
83595A	$\geq 6$
83595C	All
83596A	All
83596B	All
83597A	All
83597B	All
83598A	All
83599A	All

---

## Rack Mounting

---

**Caution** Use only the specified screws to install the rack mount kit. Longer screws can damage internal components located behind the screw mounting holes.

---

### Rack Mounting without Front Handles (Option 908)

Option 908 instruments are shipped with a rack mount kit. The kit supplies the hardware and installation instructions to prepare the instrument to mount on an equipment rack with 482.6 mm (19 in) support spacing. To order additional rack mount kits, see Table 1-4.

1. Refer to Figure 2-4. Contact your nearest sales and service office. See Table 1-5 for a list of Agilent Offices.
2. Remove each front handle trim ①:
  - a. Insert the tip of a screwdriver between the back edge of trim and the front handle.
  - b. Pull forward.
3. Remove four screws ④ and one front handle assembly ③ per side.
4. Attach one rack mount flange ② with four panhead screws ④ per side.
5. Remove the feet and tilt stands ⑤.
6. Save the flat head screws and front handle assemblies for reuse.

### Rack Mounting with Front Handles (Option 913)

Option 913 instruments are shipped with a rack mount kit. The kit supplies the hardware and installation instructions to prepare a standard instrument (with handles) to mount on an equipment rack with 482.6 mm (19 in) support spacing. To order additional rack mount kits, see Table 1-4. Contact your nearest sales and service office. See Table 1-5 for a list of Agilent Offices.

1. Refer to Figure 2-4.
2. Remove each front handle trim ①:
  - a. Insert the tip of a screwdriver between the back edge of trim and the front handle.
  - b. Pull forward.
3. Remove four screws ④ and one front handle assembly ③ per side.
4. Attach one rack mount flange ② and one front handle assembly ③ with four panhead screws ④ per side.
5. Remove the feet and tilt stands ⑤.
6. Save the flat head screws and front handle assemblies for reuse.

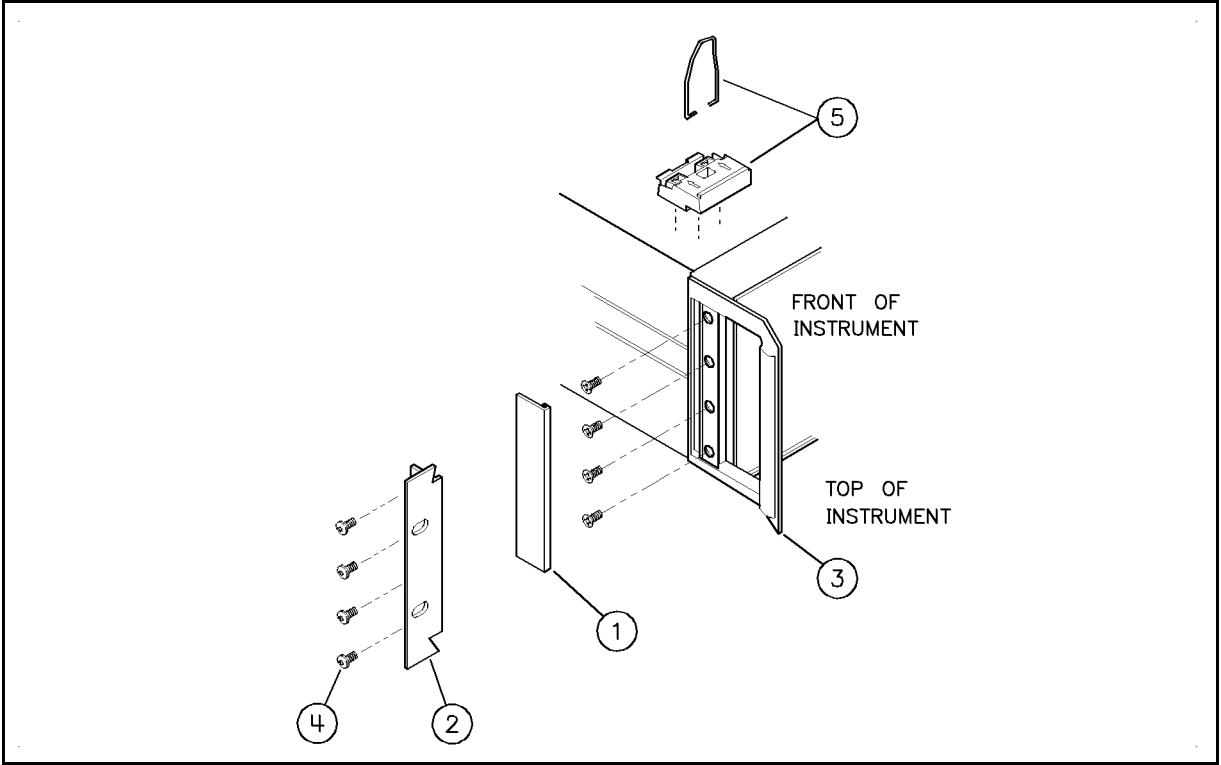

Figure 2-4. Rack Mounting the Analyzer

---

## Connecting the Analyzer to a Source

Figure 2-5, Figure 2-6, Figure 2-7, and Figure 2-8 show the interconnections between the analyzer and three commonly used sources.

### External Modulation

Unlike the HP/Agilent 8350, 8360, and 83750 Series sources, HP/Agilent 8340 and 8341 Series synthesizers do not provide an internal 27.778 kHz modulated signal (used in AC measurements). Use the analyzer's 27.778 kHz modulation signal to externally modulate the source, connected as described in Table 2-4.

**Table 2-4. External Modulation Connections**

HP/Agilent Source	Serial Prefix	Connection/Function (W/O System Interface Connected)	Connection/Function (With System Interface Connected)
8340A	< 2302A	Pulse Input/Pulse	Input/Pulse
	$\geq$ 2320A	AM Input/Shift Pulse	AM Input <sup>1</sup>
8341A	all	AM Input/Shift Pulse	AM Input <sup>1</sup>
8340B	all	Pulse Input/Pulse	Input/Pulse <sup>1</sup>
8341B	all	Pulse Input/Pulse	Pulse Input/Pulse <sup>1</sup>

<sup>1</sup> The correct function is programmed automatically.

### Other Configurations

If you operate the analyzer without connecting the HP/Agilent 8757 system interface, make the connections to the analyzer's POZ BLANK and SWEEP IN 0-10V only. Also use this configuration with the HP/Agilent 8620 Series sweep oscillator and with non-HP/Agilent sources. For modulation, connect the MODULATOR DRIVE to the source PULSE input, or use an external modulator (such as an HP/Agilent 11665B).



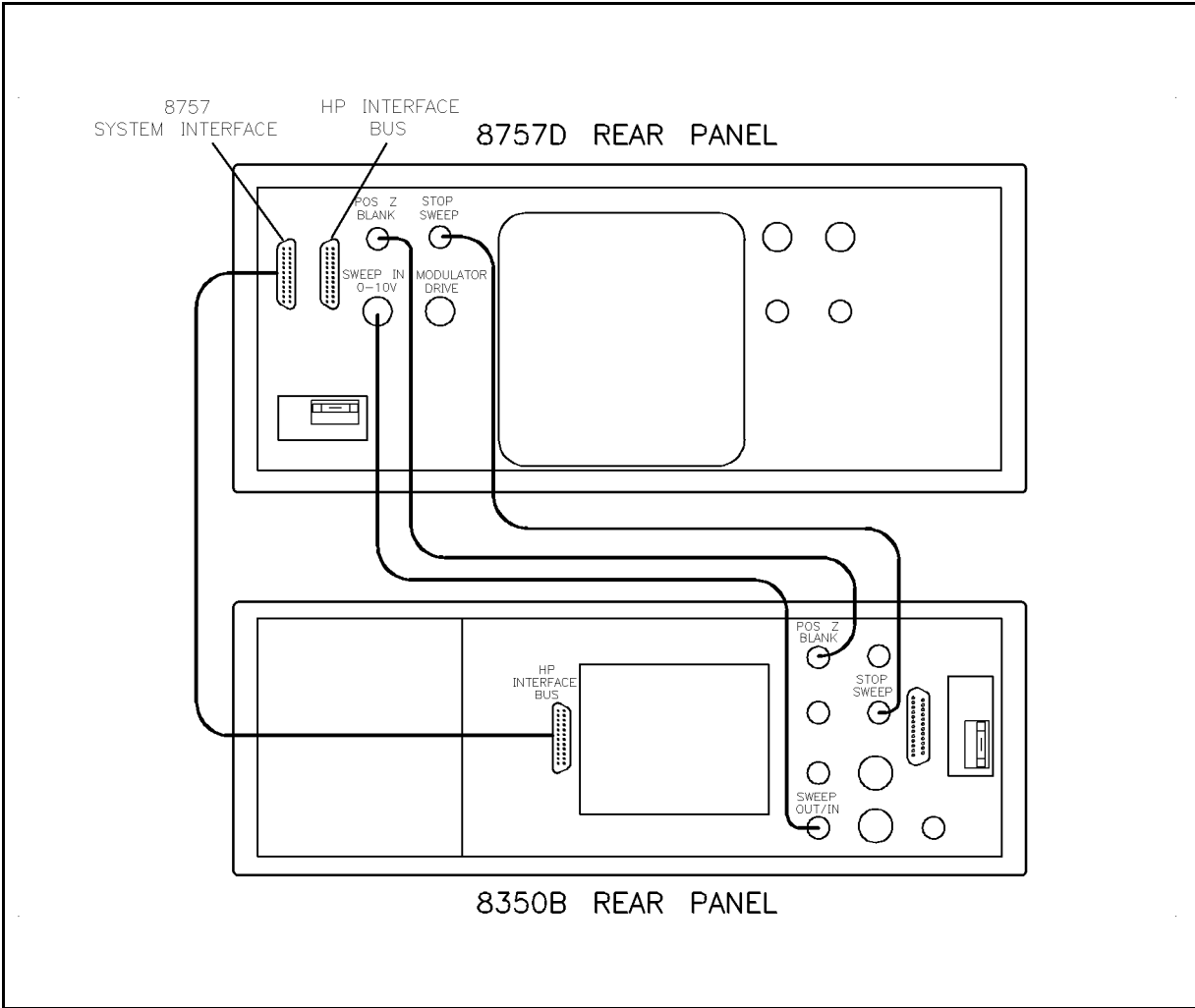

Figure 2-5. Analyzer to HP/Agilent 8350 Sweep Oscillator Interconnections

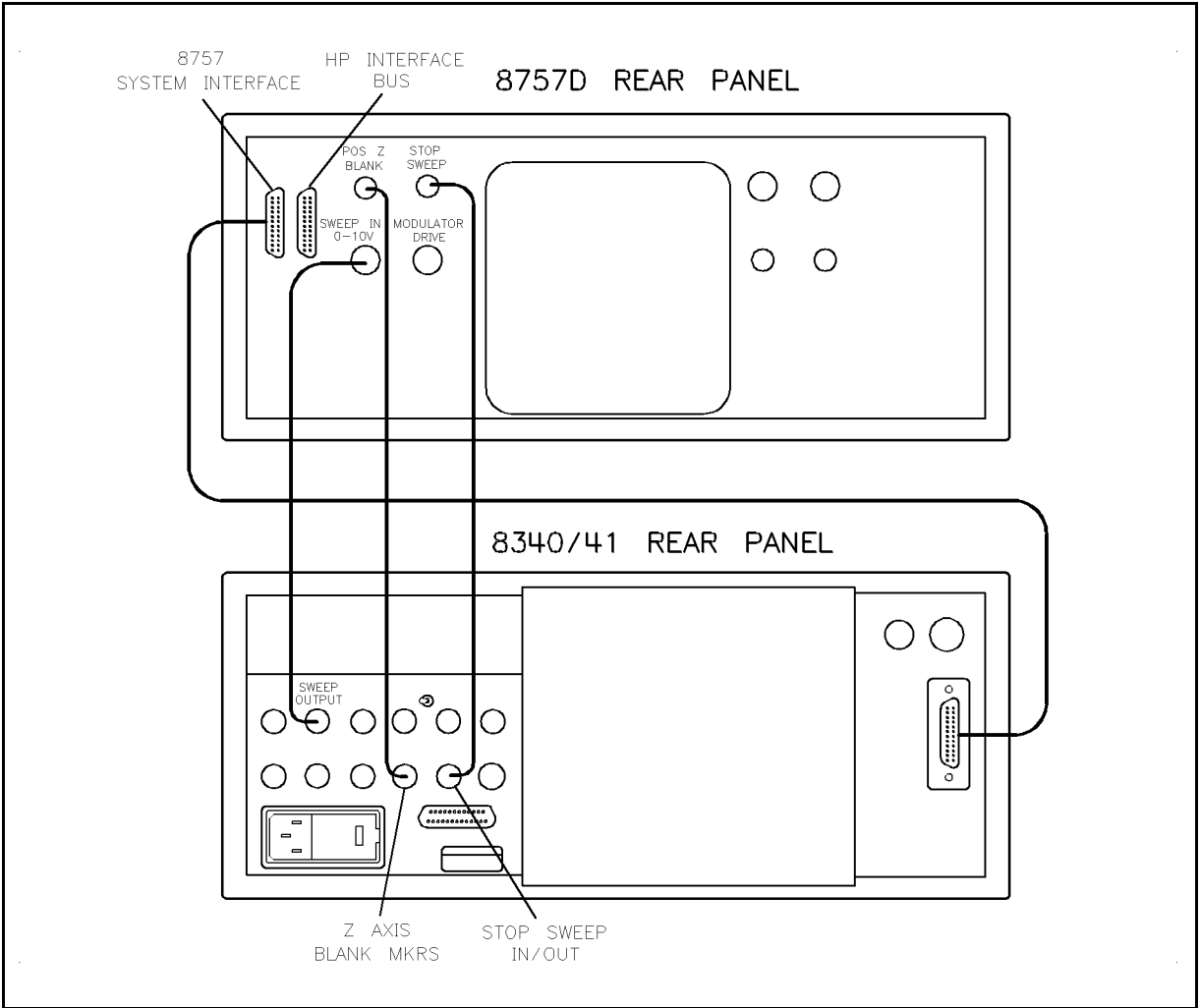

Figure 2-6. Analyzer to HP/Agilent 8340 and 8341 Series Synthesizer Interconnections

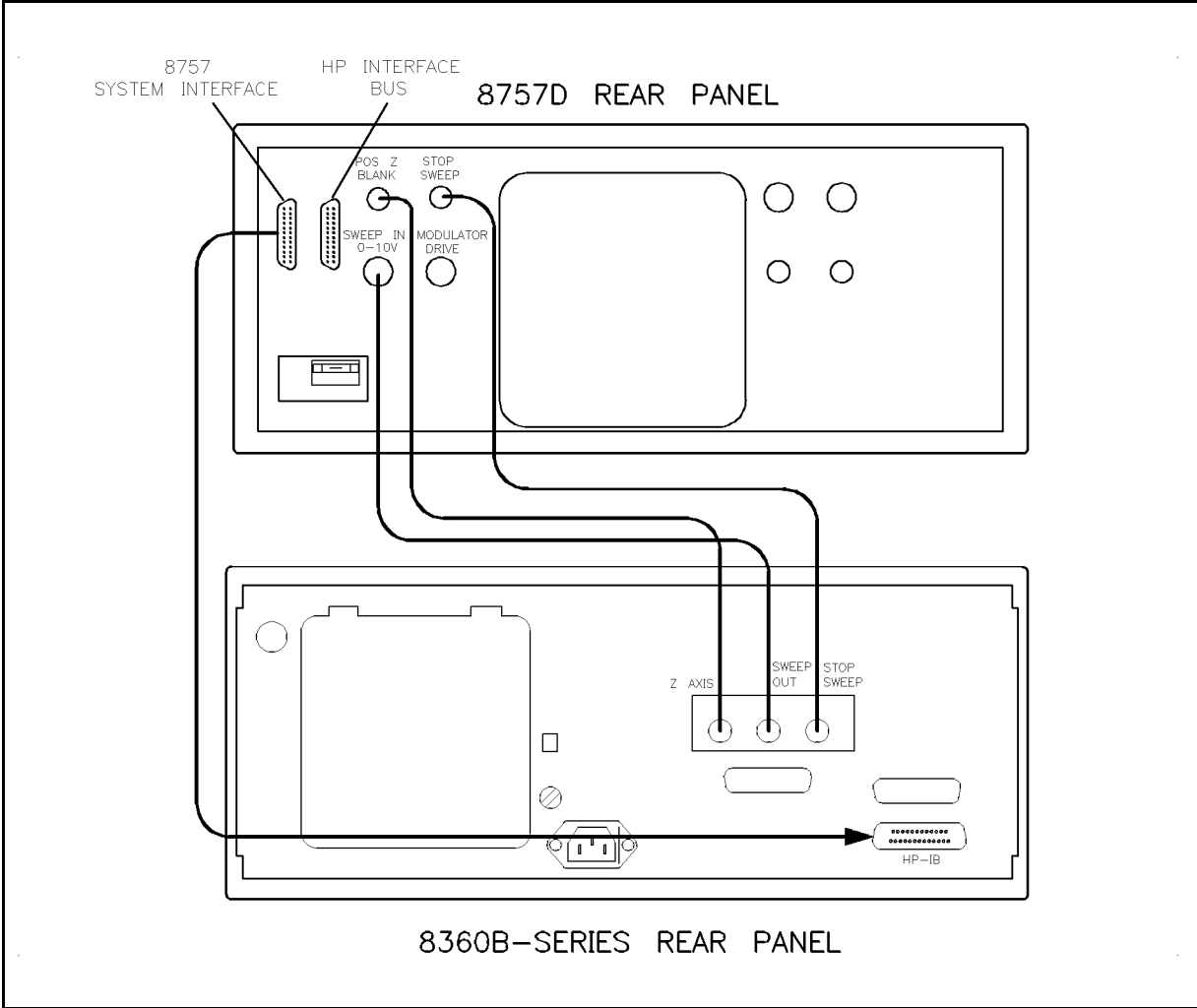
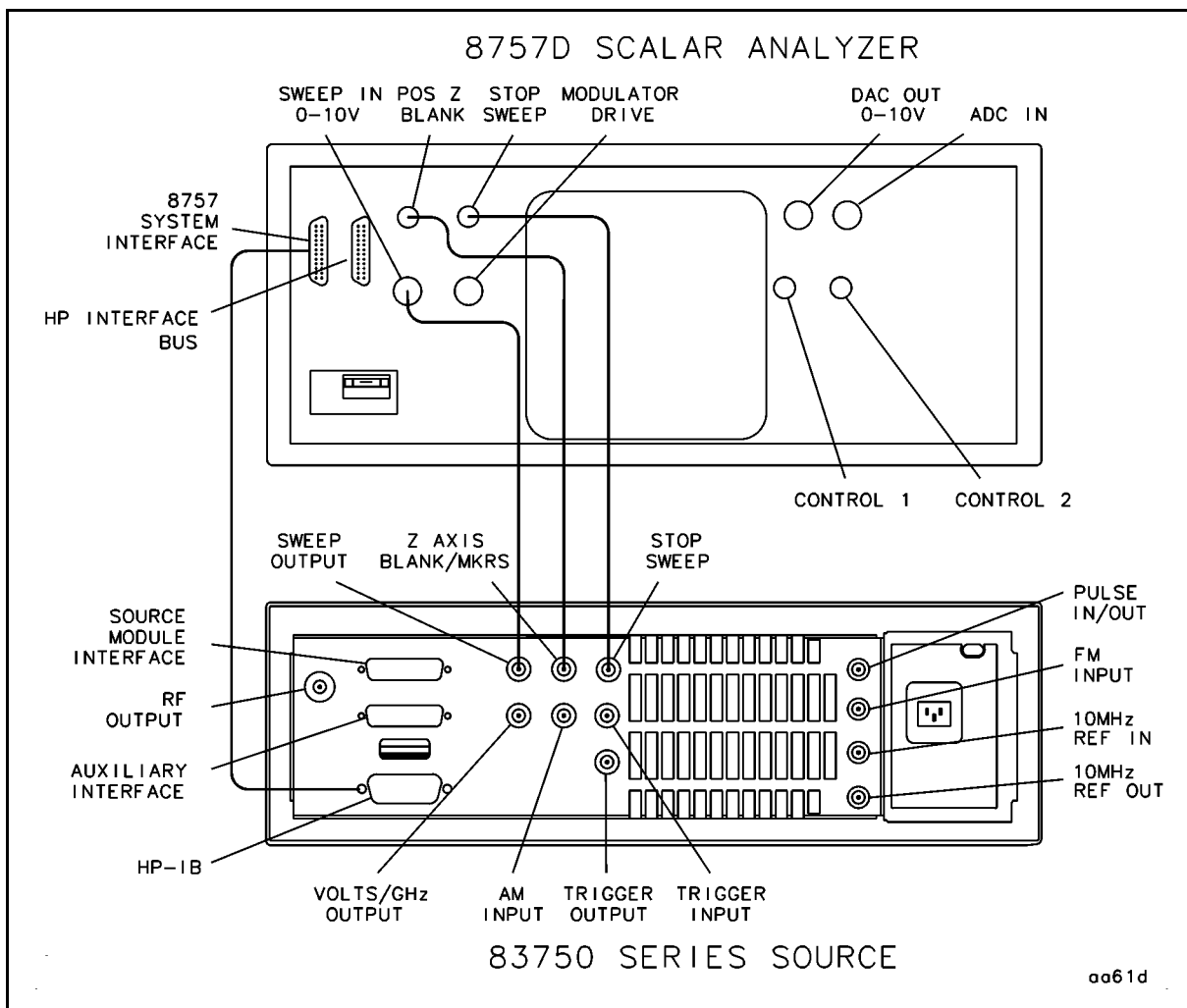
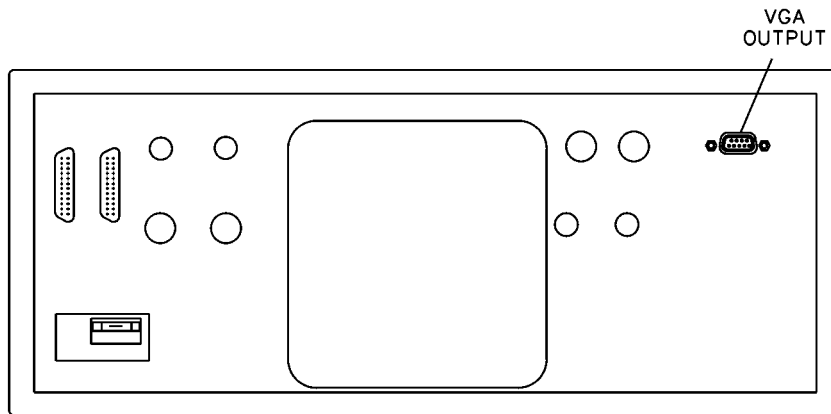

Figure 2-7. Analyzer to HP/Agilent 8360 Series Synthesizer Interconnections

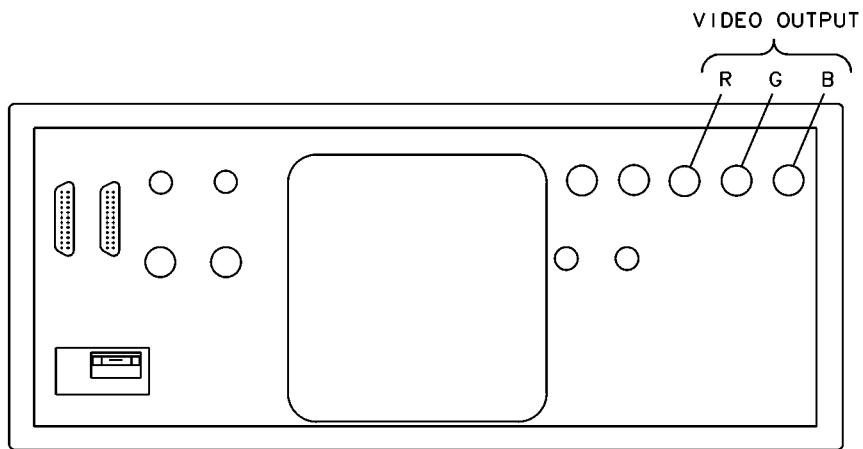

**Figure 2-8. Analyzer to HP/Agilent 83750 Series Synthesizer Interconnections**

### 8757D LCD DISPLAY CONNECTION



### 8757D CRT DISPLAY CONNECTION



oo62d

**Figure 2-9. Rear Panel Display Connectors**

---

## Connecting the Analyzer to an External Monitor

### CRT

Use the three rear panel outputs (RGB) to drive an external monitor (see chapter 1 for specific video output characteristics). Connect the three BNC analyzer outputs (RGB) to the corresponding monitor inputs.

If you use a monochrome monitor, operate the analyzer in monochrome mode and connect only the green (G) output to the monitor.

### LCD

The analyzer can drive both its internal display and an external monitor simultaneously. Connect the VGA output to the corresponding monitor input.

#### External Monitor Requirements:

VGA Compatible

- 640 (horizontal) x 480 (vertical) resolution
- 59.83 Hz vertical refresh rate
- 16.716 mS vertical time
- 31.41 kHz horizontal refresh rate
- 31.840  $\mu$ S horizontal time
- 75 ohm video input impedance
- video analog amplitude 0.7 V<sub>p-p</sub>
- negative true TTL logic for vertical and horizontal synchronization

---

## Setting the HP-IB Address

In remote mode, a controller communicates through the HP-IB, identifying each instrument on the bus by its HP-IB address. Because of this, each instrument on an HP-IB *must* have a unique address (0 through 29 are available).

### Factory Setting

The factory sets the analyzer to address 16. The central processing unit (CPU) reads this address from the firmware when the instrument is first turned on and stores it in memory. The address changes only when the value in memory changes, either through a front panel entry, or when you change the firmware. With a firmware change, the address again defaults to 16.

## Checking the Address

To display the current HP-IB address on the CRT:

1. Press **LOCAL**.
2. Select **8757**.

## Changing the Address

To change the HP-IB address:

1. Press **LOCAL**.
2. Select **8757**.

The CRT displays the current address.

3. Using the front panel keypad, enter the new address.
4. Press **ENT** to terminate the entry.

The CRT displays the new address. Turning the line switch off or presetting the instrument does not affect this address.

## Recording the Address

Figure 2-10 shows an HP-IB label (see chapter 1 for ordering information), available for recording instrument HP-IB addresses.

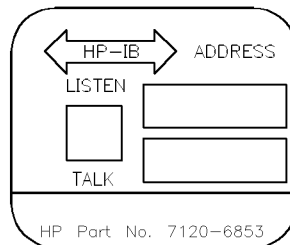

**Figure 2-10. HP-IB Address Label**

---

## HP-IB Connectors and Cables

A tutorial description of HP-IB is available from Agilent Technologies (see chapter 1 for ordering information). See also “Remote Operation,” which describes the analyzer’s HP-IB capabilities. Figure 2-11 illustrates an HP-IB connector pin configuration and signals.

### Connectors

The analyzer has two rear panel HP-IB connectors:

1. The 8757 System Interface (J1).

This remote programming interface lets you connect the analyzer to the HP-IB connector of compatible instruments and use the analyzer (in either local or remote operation) to control a plotter, printer, or source. This dedicated HP-IB port is used exclusively by the analyzer; do not connect a controller to this connector.

2. The HP Interface Bus (J2).

This remote programming interface lets you connect the analyzer to a controller via HP-IB with or without additional instruments. You can then remotely operate the analyzer with the same control (except for power, line switch, and internal tests) as with local operation. The controller maintains remote control by sending commands to and receiving data from the analyzer over the HP-IB.

### Cables

Connect instruments on the HP-IB or on the system interface using HP-IB cables. The cables are available in lengths from 0.5m (1.6 ft) to 4m (13.2 ft). See chapter 1 “General Information” for ordering information.

You may connect up to fifteen instruments in parallel on the HP-IB or the system interface, but if the system cable is too long or if the accumulated cable length between instruments is too long, the system cannot maintain the proper data and control lines voltage levels and timing relationships (see Table 2-5).

**Table 2-5. HP-IB Cabling Restrictions**

Number of Instruments in the System <sup>1</sup>	Maximum Cable Length (m/ft)
2	4/12
> 2	2/6 <sup>2</sup>
na	20/65 <sup>3</sup>

1 Including the analyzer.

2 To each instrument.

3 Between all units.



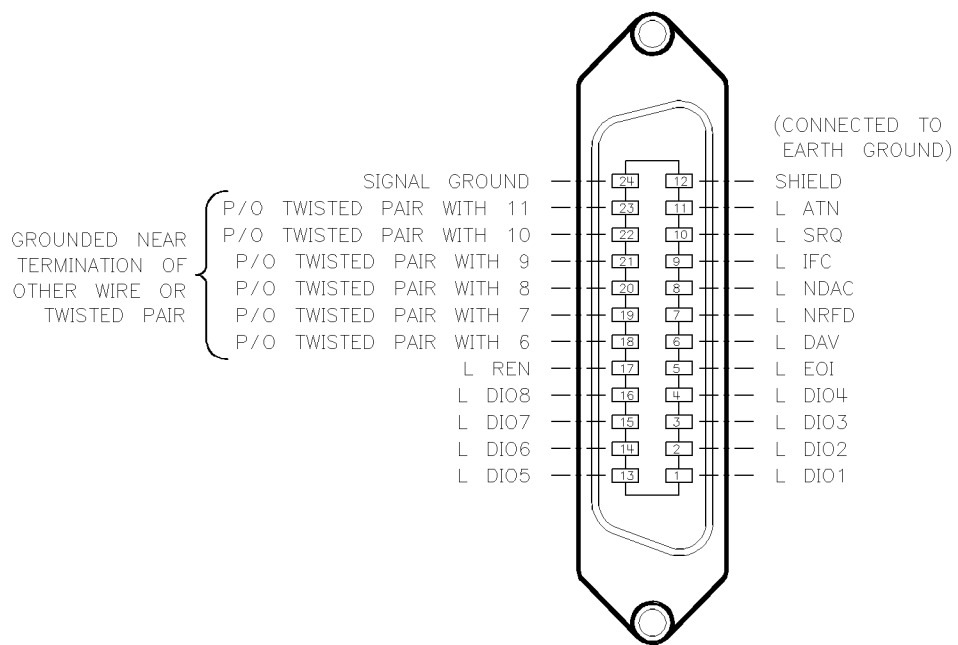

Figure 2-11. HP-IB Connectors: Signals and Pin Configuration

---

## Storing and Shipping

### Environment

Store or ship the instrument in environments within the following limits:

Temperature .....	-40 to + 70°C (-40 to + 167°F)
Altitude .....	≤ 15,240 metres (50,000 feet)
Humidity .....	90% at +65° C (+149°F)

Protect the instrument from temperature extremes, which can cause internal condensation.

### Packing the Instrument

#### Hardware

- If the analyzer has handles, but no rack mounting hardware, go to “Packaging.”
- If the instrument has neither rack mount flanges, nor handles, attach the handles, and go to “Packaging.”
- If the instrument has handles *and* rack mount flanges, remove the flanges, reattach the handles, and go to “Packaging.”
- If the instrument has rack mount flanges, but no handles, remove the flanges, attach the handles, and go to “Packaging.”

#### Packaging

Containers and materials identical to those used in factory packaging are available through Agilent Technologies offices (see chapter 1 for ordering information). If you choose to package the instrument with commercially available materials, follow these instructions.

1. Wrap the instrument in heavy paper.
2. Use a strong shipping container. A double-wall carton made of 350-pound test material is adequate.
3. Use enough shock-absorbing material (3 to 4 inch layer) around all sides of the instrument to provide a firm cushion and prevent movement inside the container. Protect the control panel with cardboard. Seal the shipping container securely.
4. Mark the shipping container “FRAGILE”.

### Returning an Instrument for Service

If your analyzer requires service, contact the Agilent office nearest you for information on where to send it. See Table 1-5. Include a service tag (located at the end of this chapter), on which you provide the following information:

1. Your company name and address (do not give a post office box).
2. A technical contact person within your company, and the person’s complete phone number including country code and area code.
3. The complete model and serial number of the instrument.
4. Indicate the type of service required (calibration or repair).
5. A detailed description of the problem and how the instrument was being used when the problem occurred (such as calibration or measurement).

When making inquiries, either by correspondence or by telephone, please refer to the instrument by model number and full serial number.



## Operation

---

---

**Note** The original HP/Agilent 8757D incorporated a cathode ray tube (CRT) based display. The current design incorporates a liquid crystal display (LCD) based display. In this manual, references to either CRT or LCD apply to both display designs unless noted otherwise.

---

The front panel LINE switch disconnects the mains circuits from the mains supply after the EMC filters and before other parts of the instrument.

### HP/Agilent 8757D Firmware Compatibility

---

**Caution** Only firmware revisions 5.1 through 6.2 can be used in HP/Agilent 8757D models with a CRT-based display (revision 6.2 is recommended). Instrument models with an LCD-base display must use firmware revision 7.0 or greater—they are not interchangeable.

---

Check the rear panel of the instrument to determine the type of display. Instruments with the LCD-based display are equipped with a VGA connector on the rear panel so that an external monitor may be connected. CRT-based instruments are equipped with three BNC connectors (RGB) for this purpose. (See Figure 2-9 in Chapter 2, “Installation.”)

This operating section provides information that is divided into the following topics and sections:

#### Local Operation (see white tab)

- *User's Guide*, which contains:
  - typical measurement setups
  - example transmission and reflection measurements
- *Operating Reference*, which contains:
  - front and rear panel operating features
  - front panel key functions
  - softkey functions
  - operator's check

## **Remote Operation (see white tab)**

For reference only. The three introductory programming guides may refer to obsolete hardware and software.

This section contains:

- information on converting HP/Agilent 8757A software
- quick reference guide
- introductory programming guides with example programs and programming codes

## **In Case of Difficulty (see white tab)**

This section contains information on what to do if you encounter a problem with the analyzer. It provides suggestions for minor problems that do not involve defects in the internal circuitry. (The service manual, chapter 8, provides in-depth troubleshooting information.)

## Remote Operation

---

### Converting Existing HP 8757A Programs

Programs written for an HP 8757A (firmware revision  $\geq 2.0$ ) require minimal or no changes to run on an HP 8757D. The major differences involve the graphics commands (see the introductory programming guides and the quick reference guide). To assist in upgrading existing software, review the following list.

#### Display Graphics (HP-GL Commands)

1. DEFAULT (DF) sets default values. This command (equivalent to: (“DI 1,0; SI 0.14,0.17;”)) places the HP 8757D in *monochrome* mode.
2. LINE TYPE (LTy,z) is not available on the HP 8757D.
3. OUTPUT P1 and P2 POSITION (OP) outputs the current P1 and P2 positions (P1 = lower left position; P2 = upper right position). The graphics display units (GDUs) define the CRT plotting area. Table 2-1 lists the display full page coordinates.

Table 2-1. Display Full-Page Coordinates

HP Analyzer	Lower Left P1(LL)	Upper Right P2(UR)	Trace Graticule	
			(LL)	(UR)
8757A	(0,0)	(2698,2047)	(198,150)	(2307,1814)
8757D	(0,0)	(2924,2047)	(214,150)	(2500,1814)

4. SELECT PEN (SP n) select the beam intensity and color displayed on the CRT. This command operates in three modes:
  - a. Monochrome display mode, set by the (DF) command, uses the (SP n) command to select between three different beam intensities and beam off.
  - b. Color mode, selected (if not already on) with the HP 8757C DEFAULT COLORS command (DEC). The *Quick Reference Guide* lists the colors associated with the different pen numbers.
  - c. HP 9000 series 200/300 BASIC color, set with the HP 8757C BASIC COLORS command (BC). For a list of the colors available, see the *Quick Reference Guide* or the *BASIC 5.0 Condensed Reference*.

**Softkey Locations** If an existing program bases any part of its operation on the HP 8757A menu structure (softkey placement), you must update the program to reflect the menu structure in the HP 8757D.

**Learn Strings** HP 8757A learn strings are fully compatible with the HP 8757D.

**Preset Timeout** Allow at least 20 seconds after an HP 8757D instrument preset for internal diagnostics to complete.



## In Case of Difficulty

---

Use the suggestions in this section if you have a minor problem with the analyzer (such as cable connections, or manual, system, or remote operation) that does not involve internal circuitry. If you need more information, refer to the service manual.

- Contents**
- Manual Operation
    - Line Power
    - Error Codes
  - System Operation
    - General
    - HP-IB Connections and Addresses
    - Other Cable Connections
    - Remote Operation
  - Inaccurate Operation
    - Calibration
    - Modulation Characteristics
    - Sweep Speed
  - Miscellaneous Problems
    - Alternate Sweep
    - Number of Trace Points and Trace Memory
    - Autozero of DC Detectors
    - Save/Recall Registers
    - System Interface On/Off
    - Measurement—Memory→Memory
    - Cursor Search
  - On-Site Service Repairs
    - Notes on Equipment Required
    - Notes on Re-Calibration
    - Main Error Codes
    - Instrument Verify
    - Other Tests:
      - EEPROM write enabled
    - Other Problems:
      - Power Calibration Error Messages
      - On-site Service-Calibration

## Manual Operation

**Line Power** With the power switch turned on, if all front panel LEDs remain off and the fan does not operate, suspect a power problem.

- Is the power line cable is properly connected?
- Is the correct line voltage selected at the rear panel power line module? See chapter 2 for installation instructions.
- Is the correct fuse installed in the line module fuse holder (see chapter 2 for the proper fuse rating for each line voltage)?

**Error Codes** When you press the front panel **PRESET** key, the analyzer performs a series of self-tests before establishing the preset conditions. If any of these tests fail, the analyzer displays an error code from 1 through 15 (in binary form) with lighted LEDs both on the front panel (the LEDs labeled R, L, T, and S in the INSTRUMENT STATE HP-IB STATUS area), and on the A3 CPU assembly (four of the eight LEDs near the top left corner of the board). In many cases, an error message also appears on the CRT. Because the front panel LEDs do not light in the event of a front panel failure, the best failure indicators are the LEDs on the CPU assembly. Table 1-1 lists the main error codes and most probable cause of failure. If you encounter an error message, refer to the service manual for troubleshooting (some additional information is provided under "On-Site Service".)

**Table 1-1. Summary of Error Codes**

LED Reading 8-4-2-1	Error Code	Test Description and Explanation	Probable Cause of Failure
1-1-1-1	15	Microprocessor kernel	A3
1-1-1-0	14	ROM checksum	A3
1-1-0-1	13	RAM checksum	A3
1-1-0-0	12	Power supply	A12
1-0-1-1	11	Instrument bus	A3, A6
1-0-1-0	10	Display interface - GSP	A3, A14
1-0-0-1	9	Display interface - DRAM bus	A14
1-0-0-0	8	Display interface - DRAM download	A14
0-1-1-1	7	Display interface - DRAM cell	A14
0-1-1-0	6	Display interface - VRAM bus	A14
0-1-0-1	5	Display interface - VRAM cell	A14
0-1-0-0	4	Display interface - Video control	A14
0-0-1-1	3	Display interface - RGB	A14
0-0-1-0	2	Interrupt test	A2, A3, A4, A6, A14
0-0-0-1	1	Other self-test failures include: EEROM write enable Battery failure Unexpected keypress Configuration error	As indicated on CRT
0-0-0-0	0	Pretest pass	—

---

## System Operation

When you configure the analyzer as the system controller with other instruments connected to the 8757 system interface bus, problems can occur in the configuration itself, rather than in a specific instrument.

### General

- Preset each instrument (or cycle the power). In normal, operation do not preset *only* the source; this can cause a system lock-up.
- Isolate each instrument: disconnect and reconnect them one at a time from the analyzer system interface. This helps locate a problem in an instrument or its connections.
- Clean all instrument filters regularly (at least monthly). A clogged filter causes overheating and consequent degradation of performance.
- If you cannot control the system from the analyzer front panel, cycle the power with the analyzer's LINE switch.
- Check that the source is compatible with the analyzer (see chapter 1 for a list of compatible source firmware versions).

### HP-IB Connections and Addresses

The system can fail if you set the instrument addresses incorrectly, or connect the HP-IB cables improperly.

- Are the HP-IB cables functional? Check for shorts, opens, and damaged connectors.
- Are that the cables for the source and other peripherals connected to the 8757 system interface connector (*not* the HP interface bus. Connect *only* a system controller to the HP interface bus).
- Is the system interface on? When off, the CRT status line displays SYS INTF OFF.
- Is the HP-IB address of each instrument set correctly?
  1. Check the *expected* address for each instrument in the system: press **LOCAL**, then select the softkey for each instrument. The CRT displays the HP-IB addresses.
  2. Check the address set at each instrument and verify that it corresponds to the expected address for that instrument displayed on the analyzer.
  3. If the addresses do not agree, either use the local menu to change the address expected by the analyzer, or reset the HP-IB address on the instrument itself.

---

### Note



---

Ensure that no two instruments have the same address.

---

## Other Cable Connections

In most applications, you must connect the analyzer STOP SWEEP, POS Z BLANK, and SWEEP OUT/IN outputs to the source (see chapter 2 for details on connecting an HP 8350, and 8340/41/60-series source). Other connections may be necessary for different applications.

## Remote Operation

Most remote operation problems occur due to improper programming.

- Does all program code have the proper syntax? Are the proper number of bytes transferred when sending or requesting data to and from the analyzer?
- When you transfer binary data, ensure that an HP 9876A printer is not connected to the bus (this can prevent proper transfer).
- A printer connected to the 8757 system interface, must *not* send out an SRQ if the paper runs out (this significantly slows system performance).
- Do not set the HP-IB address of any instrument on the 8757 system interface to a value one digit greater or smaller than the analyzer's HP-IB address (this causes conflict with the analyzer's passthrough address - see "Remote Operation" for more information on passthrough addresses).

---

## Inaccurate Operation

If the analyzer works, but you doubt the accuracy of the measurements, the problem may be with calibration or with the modulation frequency of the input signals.

- Calibration**
- Is the system correctly configured for the detectors connected? The system automatically reconfigures when you replace or exchange a detector. Press **CAL** and select **CONFIG SYSTEM**. The analyzer determines the types of detectors connected and calibrates each input.
  - If you use DC detection, zero the detectors to compensate for the effects of DC drift (press **CAL** and select **DC DET ZERO**; choose manual or automatic zeroing).
  - Enter the correct detector offset value; the status line shows which detectors have an offset entered (press **CAL** and select **DET OFFSET**; verify or change the offset values for each detector input). Remember that instrument preset will reset the offset values to zero.
  - For further information on calibration procedures, refer to the Operating Reference.

- Modulation Characteristics**
- If you use AC detection, verify that the modulation frequency of the input signals to the detectors is 27.778 kHz  $\pm$ 20 Hz. The ON/OFF ratio must be at least 30 dB, with an ON/OFF symmetry of 50/50  $\pm$ 5%

- Sweep Speed**
- If you use the 8757 system interface, the analyzer automatically limits the sweep speed. Without the system interface, you must to ensure proper sweep speed. Refer to chapter 1 "Specifications".

- Calibrator Option 002 Only**
- Refer to the *Service* manual for a simple accuracy test of the calibrator using only a power meter and a power splitter.

---

## Miscellaneous Problems

The following information may clarify some analyzer features.

### Alternate Sweep

The alternate sweep feature lets you simultaneously test a device over two distinct frequency ranges or power levels; in this mode, the analyzer displays the alternating sweep conditions at the same time. Use this feature, for example, to test a filter's broadband and passband characteristics simultaneously by alternating the source state between a broadband and narrowband frequency range, or test an amplifier in both its linear and compressed operating regions by alternating the source state between two power levels.

### Notes



---

For the alternate sweep function to operate, you must connect the analyzer's system interface to the source's HP-IB interface. Also, ensure that the system interface is turned on.

You cannot save alternate state information. If you try to save alternate state, the analyzer disables the alternate sweep mode.

---

### Using Alternate Sweep

1. Set up the analyzer for the desired measurement on channels 1 and 2 (A, B, R, A/R, B/R, and so on).
2. Turn channels 3 and 4 off.
3. Define one source state as the primary configuration and the other as the secondary (alternate) configuration. For a filter measurement, you could define a broadband sweep as the primary configuration (measured and displayed on analyzer channel 1) and a narrowband sweep as the secondary (measured and displayed on analyzer channel 2).
4. Select channel 2 and set up the source for the secondary configuration.
5. For a normalized measurement, calibrate the system and set the analyzer to display MEAS-MEM on channel 2.
6. Store this state in analyzer register 2.
7. Select channel 1 and set up the source for the primary configuration.
8. For a normalized measurement, calibrate the system and set the analyzer to display MEAS-MEM.
9. Store this state in analyzer register 1.
10. Activate the alternate sweep function on the source and enter register 2 as the alternating register.

The source alternates between the sweep conditions stored in registers 1 and 2, and the analyzer displays the measurement results for both conditions. For more information on the alternate sweep function, refer to the HP 8757 User's Guide.

## **Number of Trace Points and Trace Memory**

The number of trace points selected defines the number of channels that the analyzer can display on the CRT. If you select 101, 201, or 401 points, the analyzer can display all four channels. Selecting 801 trace points limits the available channels to 1 and 2, and with 1601 trace points, the analyzer can display only channel 1.

Choosing 801 or 1601 points destroys the channel trace memory for the channels which were turned off.

## **Autozero of DC Detectors**

In DC detection mode, the analyzer periodically zeros its AC/DC detectors to maintain accurate low-level measurements. When using a source connected to the 8757 system interface, you can engage the autozero function and let the analyzer control the source power off/on sequence. To preserve the source front panel settings, the analyzer must use save/recall register 9 on both the source and the analyzer. Because the analyzer accesses register 9 (and writes over existing information) each time it performs an autozero (whether forced by the operator or the autozero repeat function), do not use register 9 to store information.

## **Save/Recall Registers**

The save/recall registers store the following information (most of the front panel settings; some system menu functions are not stored because they apply to every instrument state, rather than to a specific channel):

- The channel status (the active channel, and turned-on channels).
- Detection mode (AC or DC).
- Number of trace points.
- Internal modulation on/off status.
- Cursor on/off status.
- Cursor position.
- Cursor delta on/off status.
- Cursor delta position.
- Cursor search value.
- Adaptive normalization on/off status.1
- Non-standard sweep on/off status.
- Limit line on/off status (channels 1 and 2).
- For all channels:
  - Measurement selected (A, A/R, etc.).
  - Display mode (MEAS, MEM, etc.).
  - Averaging on/off status.
  - Averaging factor.
  - Reference level.
  - Reference position.
  - Scale per division.
  - Smoothing on/off status.
  - Smoothing factor.

Registers 1 through 4 also save the following:

- Trace memory at 401 points for channels 1 and 2.
- Limit line entries for channels 1 and 2.
- Title.

The following information applies to the entire instrument rather than the individual channels, and is *not* saved:

- System Interface on/off status.
- Labels on/off status.
- Title on/off status.
- Frequency labels on/off status.
- Repeat autozero on/off status.
- Color selection.
- CRT intensity.
- HP-IB addresses.
- Disk unit number.
- Disk volume number.

## System Interface On/Off

The analyzer uses the 8757 system interface bus to control the other instruments connected to the system interface. Turn the 8757 system interface on in most applications (the CRT status line displays `SYSINTF OFF` when the system interface is off). When the system interface is off, the analyzer has no control or knowledge of any HP-IB instrument connected to this interface. To turn the system interface on, press `(SYSTEM)` and select `MORE SWEEP MODE SYSINTF ON`.

### Remember



---

No two instruments connected to the system interface may have the same HP-IB address, or the analyzer may freeze operation until you correct the situation (see “Installation” for information on verifying or changing HP-IB addresses).

---

Turning the system interface off makes the following analyzer system functions impossible:

- Autozero of DC detectors.
- Alternate sweep.
- Start/stop/cursor frequency annotation.
- System save/recall and preset.
- System CW and manual sweep modes.
- Adaptive normalization.
- Hard copy plot and print.
- Disk access.

If you try to plot or print with the system interface turned off, the analyzer performs an instrument preset after a few seconds.



**Measurement—Memory**  
→**Memory**

You can use this function only with ratio measurements.

**Cursor Search**

Search functions differ from normal cursor operation. The cursor updates with every sweep to reflect the present amplitude response at the cursor frequency. In search left, search right, and bandwidth modes, the trace is held after the first search, and the trace freezes on the CRT so you can inspect the trace without it changing.

You can exit search mode and return to the normal cursor mode in two ways:

1. Select **PRIOR MENU** **CURSOR OFF**.
2. Press **CURSOR**.

---

**ON-SITE SERVICE -  
REPAIRS**

On-site analyzer repair includes assembly level troubleshooting, replacement of the defective assembly, and possible re-calibration. The equipment required to re-calibrate varies with the failure. The service manual gives complete troubleshooting instructions. This guide will quickly resolve 90% of the failures where error messages are displayed and other obvious failures (such as a dead A, B, C or R input). The motherboard must be functional, with no opens or shorts. Because of the extra equipment required to perform service and repairs, on-site service for the option 002 A5 CAL/MOD board assembly is not available. This guide is organized by error code or error message. Error code interpretation is described in "Error Codes."

Notes on Equipment Required:

Where the HP 11613A/B calibrator is listed as required equipment, a computer with disk drive is also required. The computer must be an HP 9000 series 200/300 computer or a PC with HP Basic for Windows 7.0 or greater (or equivalent) and an HPIB interface. Follow the instructions provided with the calibrator.

Where a DVM is listed, use a digital voltmeter with at least 4.5 digits of resolution, except during adjustment of the A4 board, where 5.5 digits are required.

Notes on Re-calibration:

If the A1, A2, A5 (non option 002), A6, A11, A13, A14, or A16 assemblies are replaced, perform no adjustments.

The option 002 A5 board *does* require generation of cal constants on the A3 board.

If the A3, A4, A7, A8, A9, or A10 assemblies are replaced, regenerate the cal constants with the HP 11613A/B.

If the A3 assembly is replaced on an option 002 instrument, more extensive calibration equipment will be required in addition to the 11613A/B. Refer to sections 4 and 5 of the service manual for more information. If no test equipment is available and the A3 assembly must be replaced, proper calibrator operation can be restored by removing the EEPROMS (U4 and U26) from the failed A3 board and installing them onto the replacement A3 board.

If the A12 power supply is replaced, adjust all supply voltages. Adjust all power supplies within 0.05 volts of their nominal voltages. Adjust the 5 volt supplies to 5.1 volts.

Replacing the A15 display requires no adjustments although the intensity levels may vary slightly from the previous display.

If the A4 ADC board is replaced, check the DAC gain adjustment with a DVM. Use the following procedure after the analyzer has warmed up:

1. Connect DVM LO to A4TP4 (AGND) and DVM HI to A4TP2 (DAC). Both test points and A4R6 are accessible without removing the A4 assembly cover.
2. Preset the analyzer.
3. Note the maximum SWEEP DAC VOLTAGE (approximately 0.0 V) indicated on the DVM by pressing [SYSTEM] [MORE] [SERVICE] [A4 ADC] [MORE] [CHANNEL VOLTS] [CHANV OTHER] [SWP DAC MAX].
4. Note the minimum SWEEP DAC VOLTAGE on the DVM by pressing [SWP DAC MIN]. The difference between this value and the value noted in step 3 should be  $-10.2375 \pm 0.0005$  VDC. If not, adjust A4R6 (DAC ADJ) to bring the difference within specification.
5. Repeat steps 3 and 4 until this difference is attained.

## MAIN ERROR CODES

### ■ Error Codes 15 through 13:

Failure:

All of these codes are associated with the A3 CPU board. Replacement of the A3 board will restore operation.

Equipment Required: HP 11613A/B.

### ■ Error Code 12:

Failure:

One or more of the power supplies have failed. First check all fuses. Remove boards one at a time (except the A3 CPU board), and cycle the power each time to check for board shorts. If none of these solve the problem, replace the A12 power supply board.

Equipment required: DVM (if the A12 is replaced.)

■ **Error Code 11:**

Failure:

The A3 CPU cannot communicate with the A6 board via the instrument bus. Either the A3, the A6, or the motherboard could be bad. Since the bus also goes to other boards, remove the A2, A4, and A14 boards to eliminate the possibility of shorts on these boards. Verify that the same failure occurs. If it does, replace all the boards that were removed, remove the A6 board, and close switch A3S1-D. This will bypass all self tests. If the instrument then seems to perform normally (locally), the problem is with the A6 board; if it does not perform normally, the problem is with the A3 board.

Equipment required: HP 11613A/B (if the A3 is replaced.)

■ **Error Code 10:**

Failure:

The A3 CPU cannot communicate with the A14 display interface board. Either board could be bad, or the ribbon cable, W8, could be bad. Since the A3 has been well tested already, there is a 90% chance that the A14 board caused the failure. No test equipment or re-calibration is required.

■ **Error Codes 9 through 3:**

Failure:

All these error codes relate to the A14 display interface board. Replacement of this board should cure the problem. No test equipment or re-calibration is required.

■ **Error Code 2:**

Failure:

The A3 CPU has encountered an interrupt it was not expecting, or did not receive one it did expect. Interrupts come from the A2, A3, A4, A6, or A14 boards. The problem could also be on the motherboard. Extensive troubleshooting is required to isolate this problem. Either substitute known working boards for those listed, or refer to the service manual for further information.

■ **Error code 1:**

Failure: A failure has occurred with either the instrument verify routine or with the other tests listed.

Equipment required: Varies with the failure.

INSTRUMENT VERIFY

- RAM: Replace the A3 CPU board.
- Instrument Bus: See error code 11.
- Display Bus: See error code 10.

- Timer: Replace the A3 CPU board.
- ADC Measurement: Check the  $\pm 15\text{V}$  power supplies for accuracy. If OK, replace the A4 board.
- ADC Bit Check: Same as ADC Measurement.
- DAC Bit Check: Same as ADC Measurement.
- Sweep Compare: Same as ADC Measurement.
- Detector Control: Same as ADC Measurement.

#### OTHER TESTS

EEROM Write Enabled: Close switch A3S1-E. This is a warning; not a failure.

Battery Failure: Replace the battery on the A3 board, then cycle the power twice. The error message should disappear; if not, replace the A3 CPU board.

Note: The battery life should be about 10 years.

Unexpected Key Press: Either a front panel key is stuck (as indicated on the display) or the A2 board is defective. Check the indicated key or replace the A1 or the A2 board.

Configuration Error: This generally does not indicate a failure. Contact your local HP sales or service office for more information.

#### ■ Other Problems

Default calibration table used on A, B, C, or R: This indicates a need to recalibrate using the HP 11613A/B. If the problem persists, it indicates a problem with the A3 CPU board.

If one input always seems bad and there is no detector offset active for that input, suspect the logger board for that input (A7, A8, A9, A10 for inputs A, B, C, R, respectively). Verify this by interchanging the logger board to see if the problem follows the board. Be sure to replace the boards in their original position. If the problem does not follow the board, it indicates a problem with the A4 ADC board.

Failure to sweep properly or “Sweep Sync Errors” indicate a problem on the A4 ADC board (assuming the source used is functioning properly).

Lack of any signal displayed when using the modulator drive output from the analyzer could indicate a failed A5 modulator drive board. Measure the open circuit output voltage at the MODULATOR DRIVE BNC on the rear panel. When the modulator drive is turned off, the output should be about +6.4 volts DC. When the modulator drive is on, the output voltage should be about 6 volts AC. Failure to turn on is probably caused by the A5 board, but could also be caused by the A3 CPU board.

Any of the following error messages indicate either a problem on the A3 CPU board or a problem in the firmware. If the problem occurs continuously, suspect the A3 board. If the problem only occurs during a specific keystroke sequence, it may be caused by a problem in the firmware. These messages may be accompanied with a numeric error code and flashing LEDs on the front panel and on the A3DS2 LEDs. Please note these messages and error codes when returning the instrument or board assembly to HP.

The messages are:

BUS ERROR  
Adr Error  
Code Err  
Zero Div  
Chk Instr  
Trap Instr  
Priv violation  
Trace  
-1010 emulator  
-1111 emulator  
Processing Error

### **Power Calibration Error Messages**

The HP 8757D Option 002 power calibration process senses when improper connections are made. The following error messages describe the type of connection error detected. These are *not* tested during self test but rather at the beginning of or during the power cal routine.

CHECK CONNECTIONS CALIBRATION ERROR #1      The HP 8757D has detected power applied to the detector from a source other than the calibrator.

CHECK CONNECTIONS CALIBRATION ERROR #2      The HP 8757D has not measured power at the detector when the calibrator is programmed to generate power. apparently, the detector is not connected to the calibrator output, or the incorrect input was selected by the operator for calibration.

CHECK CONNECTIONS CALIBRATION ERROR #3      The HP 8757D has found that the detector was disconnected from the calibrator output before the calibration process was complete.

CALIBRATOR ERROR #1      The HP 8757D firmware has detected a problem with the calibration data stored in the instrument's CPU

EEPROM. Refer to the *Service* manual.

CALIBRATOR ERROR #2 (or greater) The HP 8757D firmware has detected a problem with the calibrator hardware. Refer to the *Service* manual.

### **Detector Error Messages (HP 85037A/B only)**

All HP 85037A/B detectors contain cal constants within their own internal EEPROMs. Any corruption of data or digital hardware failure in the detector will generate an error message as soon as the detector is plugged in. This message is: EEPROM read failed -- A (or B, C, R)

If this message appears, the detector must be repaired or replaced.

---

### **On-Site Service - Calibration**

Calibration can be quickly and easily performed with the HP 11613A/B calibrator (software 3.0 or greater). A computer with a disk drive is required, such as a HP 9000 series 200/300 computer or a PC with HP Basic for Windows 7.0 or greater and a compatible HP-IB interface. Follow the instructions provided with the calibrator.

The entire process (except for analyzer warm-up) takes less than 15 minutes. Option 002 requires an additional calibration that may not be practical to perform at a customer site because the required equipment is generally not available.

# Glossary

---

**Abort**

To cut short or break off an action, operation, or procedure.

**Active Channel**

The highlighted channel affected by front panel functions.

**Address**

The identification (represented by a name, label, or number) for a register, location in storage, or any other data source or destination (such as the location of a station in a communications network, or a device on the HP-IB).

**ALC**

An abbreviation for automatic level control, the process of monitoring and maintaining constant source power output.

**Analog**

Of or pertaining to the general class of devices or circuits in which the output varies as a continuous function of the input.

**Annotation**

The labeling of specific information on the CRT (such as frequency or power).

**Aperture**

The amount of a trace (in percent) on either side of a given point averaged to perform the smoothing function.

**Array**

A set of numbers or characters that represents any given function.

**ASCII**

1. An abbreviation for American Standard Code for information interchange.
2. A specific format used to transfer information to and from the analyzer.

**AUX**

An abbreviation for auxiliary; refers to rear-panel input.

**Binary**

1. A method of representing numbers in a scale of two (on or off, high-level or low-level, one or zero).

2. A compact, fast format used to transfer information to and from the analyzer.

**Bit**

The smallest part of information in a binary notation system.

**Brightness**

See **Color Brightness**.

**Buffer**

A storage device used when transmitting information to compensate for a difference in the rate of flow of information between two devices.

**Bus**

One or more conductors used as a path to deliver transmitted information from any of several sources to any of several destinations.

**Byte**

Eight bits of data representing one character processed as a unit.

**Calibration**

A process or operation that removes or reduces measurement errors.

**Checksum**

A summation of digits or bits used primarily for checking purposes.

**Chip**

An integrated circuit (IC).

**Clamp**

To limit a signal at a specific level.

**Color**

1. That aspect of light sources caused by differing qualities of the light they emit. The three parameters used to describe color:

- a. Intensity (brightness, luminosity).
- b. Saturation (color, chromaticity).
- c. Hue (tint).

2. A softkey label representing saturation (a color parameter).

**Color Brightness**

A measure of the intensity (brightness) of a color.

**Command**

A set of bytes that defines an instrument (or computer) operation.



**Controller**

1. A device capable of specifying the talker and listeners for an information transfer.
2. An external computer connected to an instrument to control its operation.

**CPU**

An abbreviation for central processing unit. Used to refer to the A3 assembly or 68000 chip on the A3 assembly.

**CRT**

An abbreviation for cathode ray tube. In this document, refers to the display screen.

**Cursor**

An electronically generated pointer that moves across the trace to identify point values.

**CW**

An abbreviation for continuous wave; refers to a single frequency (rather than a swept frequency).

**dB**

An abbreviation for decibel. A relative unit of measure.

**dBm**

An abbreviation for power in decibels in terms of its ratio to 1 mW.

**Default**

A known set of conditions used by the analyzer in the absence of user-defined conditions.

**Detector**

A device used with the analyzer that converts a microwave signal to a 27.778 kHz signal, which the analyzer can interpret.

**Digital**

Of or pertaining to the class of devices or circuits in which the output varies in discrete steps.

**Dimension**

1. To specify the size of an array.
2. The number of array rows or columns.

**Disk**

A circular, magnetic storage medium.

**Display**

1. To show annotation and measurement data on the CRT/LCD.
2. The CRT or LCD and its associated driver circuits (A15).

**Engage**

To activate a function.

**Enter**

1. The process of inputting information to the analyzer.
2. The hardkey **ENT**.

**EPROM**

An abbreviation for electronically programmable, read-only memory.

**ESD**

An abbreviation for electrostatic discharge.

**Firmware**

Programs or instructions stored in read-only memory (EPROM).

**GDU**

Graphics display units.

**GSP**

An abbreviation for graphics system processor (A14U25); the central controller for all display processing.

**Graticule**

An electronically-drawn grid on the CRT.

**Hardkey**

A front panel key, which engages a single analyzer function or presents a single menu of softkeys.

**Hex**

An abbreviation for hexadecimal number system (base 16).

**Horizontal Resolution**

How closely spaced the analyzer takes horizontal data points over the full sweep.

**HP**

An abbreviation for Hewlett-Packard.

**HP-IB**

An abbreviation for Hewlett-Packard interface bus, HP's hardware, software, documentation, and support for IEEE-488 and IEC-625 worldwide standards for interfacing instruments.

**Hue**

1. The dimension of color referred to a scale of perceptions ranging from red through yellow, green, and blue, and back to red.
2. A particular gradation of color; tint; shade.

**IC**

An abbreviation for integrated circuit.

**IEEE**

An abbreviation for Institute of Electrical and Electronics Engineers.

**Initialize**

The process that assigns information locations to a disk to prepare the magnetic media to accept files.

**Insertion Loss**

The difference between the power measured before and after the insertion of a device.

**Intensity**

Brightness; emitting or reflecting light; luminosity.

**Interpolate**

To determine a value of a signal between two adjacent points by a procedure or algorithm.

**I/O Path**

Input/output path.

**LCD**

An abbreviation for liquid crystal display. Used in place of the CRT in recent models.

**Local Lock Out**

A condition or command that prevents analyzer front-panel entries (and disables the **Local** key).

**Local Operation**

To operate manually from the front panel.

**Log**

An abbreviation for logarithm.

**Logger**

A circuit designed to output a voltage proportional to the log of an input voltage.

**Magnitude**

The magnitude of variation in a changing signal from its zero value. The length of a vector.

**Marker**

An indicator at a specified frequency point.

**Menu**

A selection of softkey choices.

**Microprocessor Kernel**

The devices critical to basic microprocessor operation.

**Monitor**

Any external display.

**Monochrome**

Having only one color (chromaticity).

**Multisync**

A type of monitor that can synchronize its horizontal sweep to various frequencies within a specified range.

**Nit**

The unit of luminance (photometric brightness) equal to one candela per square meter.

**Normalize**

To subtract one trace from another to eliminate calibration data errors or to obtain relative information.

**PAL**

1. An abbreviation for programmable array logic.
2. A programmable multiple input/output device that outputs a specific pattern for a given input.

**Passthrough Mode**

The analyzer mode that allows reception of a controller's HP-IB commands by devices on the analyzer's system interface bus.

**Port**

a circuit (or device) input or output point.

**Power Calibrator**

A 50 Mhz source used only in the HP 8757D scalar network analyzer option 002 instruments. The power can be precisely controlled in 1dB increments from +20 to -55dBm.

**Preset**

1. A pre-defined instrument state (that also runs an analyzer self-test).
2. The action of pushing the **Preset** key.

**Raster**

The process of drawing on the CRT by deflecting an electron beam rapidly from left to right and relative slowly from top to bottom.

**Reflection**

The phenomenon in which a traveling wave that strikes a discontinuity returns to the original medium.

**Remote**

A mode of operation where another device (or computer) controls an instrument via the HP-IB. In this mode, the instrument front panel keys are disabled.

**Return Loss**

The ratio (expressed in dB) between power incident upon and power reflected from a device. Calculated as  $-20\text{Log}_{10}\rho$  (where  $\rho$  is the reflection coefficient in magnitude).

**RPG**

1. An abbreviation for rotary pulse generator.
2. The analyzer front panel knob.

**Saturation**

The degree of color purity, on a scale from white to pure color.

**Scalar**

1. A quantity that has magnitude but no phase.
2. A network analyzer capable of measuring only magnitude.

**Self-Test**

A group of tests performed at power-up (or at preset) that verify proper instrument operation.

**Softkey**

A key with a function defined by the current instrument state.

**Source**

A device that supplies signal power; in this document, refers to a sweep oscillator or synthesized sweeper.

**Sweeper**

A signal source that outputs a signal that varies in frequency.

**SWR**

An abbreviation for standing wave ratio, calculated as  $(1 + \rho) \div (1 - \rho)$ .

**Sync**

An abbreviation for synchronization, or synchronized.

**Termination**

A load connected to a transmission line or other device.

**Thru**

An abbreviation for through, used to refer to a calibration technique.

**Tint**

A shade of color; hue.

**Toggle**

To switch states, usually to change a function from on to off, or off to on.

**Transmission**

The measurement of the insertion loss or gain of a network or device.

**Transparent**

Something that is not visible to the user. Usually a procedure that occurs without the user's initiation or knowledge.

**Variable**

A symbol, the numeric value of which changes either from one iteration of a program to the next, or within each iteration of a program.

**Vector**

1. A quantity that has both magnitude and phase.
2. A network analyzer capable of measuring both magnitude and phase.

**Vertical Resolution**

The degree to which an instrument can differentiate between two closely-spaced signal amplitudes.