

User's Guide

**Agilent Technologies
8719ET/20ET/22ET
8719ES/20ES/22ES
Network Analyzers**



Agilent Technologies

Part Number: 08720-90392

Printed in USA

April 2012

Supersedes: June 2002

© Copyright 1999–2002, 2012 Agilent Technologies, Inc.

Notice

The information contained in this document is subject to change without notice.

Agilent Technologies makes no warranty of any kind with regard to this material, including but not limited to, the implied warranties of merchantability and fitness for a particular purpose. Agilent Technologies shall not be liable for errors contained herein or for incidental or consequential damages in connection with the furnishing, performance, or use of this material.

Certification

Agilent Technologies certifies that this product met its published specifications at the time of shipment from the factory. Agilent Technologies further certifies that its calibration measurements are traceable to the United States National Institute of Standards and Technology, to the extent allowed by the Institute's calibration facility, and to the calibration facilities of other International Standards Organization members.

Regulatory Information

The regulatory information is located in [Chapter 8 , “Safety and Regulatory Information.”](#)

Warranty

THE MATERIAL CONTAINED IN THIS DOCUMENT IS PROVIDED “AS IS,” AND IS SUBJECT TO BEING CHANGED, WITHOUT NOTICE, IN FUTURE EDITIONS. FURTHER, TO THE MAXIMUM EXTENT PERMITTED BY APPLICABLE LAW, AGILENT DISCLAIMS ALL WARRANTIES, EITHER EXPRESS OR IMPLIED WITH REGARD TO THIS MANUAL AND ANY INFORMATION CONTAINED HEREIN, INCLUDING BUT NOT LIMITED TO THE IMPLIED WARRANTIES OF MERCHANTABILITY AND FITNESS FOR A PARTICULAR PURPOSE. AGILENT SHALL NOT BE LIABLE FOR ERRORS OR FOR INCIDENTAL OR CONSEQUENTIAL DAMAGES IN CONNECTION WITH THE FURNISHING, USE OR PERFORMANCE OF THIS DOCUMENT OR ANY INFORMATION CONTAINED HEREIN. SHOULD AGILENT AND THE USER HAVE A SEPARATE WRITTEN AGREEMENT WITH WARRANTY TERMS COVERING THE MATERIAL IN THIS DOCUMENT THAT CONFLICT WITH THESE TERMS, THE WARRANTY TERMS IN THE SEPARATE AGREEMENT WILL CONTROL.

Assistance

Product maintenance agreements and other customer assistance agreements are available for Agilent Technologies products. For any assistance, contact your nearest Agilent Technologies sales or service office. See [Table 8-1](#) for the nearest office.

Safety Notes

The following safety notes are used throughout this manual. Familiarize yourself with each of the notes and its meaning before operating this instrument. All pertinent safety notes for using this product are located in [Chapter 8](#), “Safety and Regulatory Information.”

WARNING Warning denotes a hazard. It calls attention to a procedure which, if not correctly performed or adhered to, could result in injury or loss of life. Do not proceed beyond a warning note until the indicated conditions are fully understood and met.

CAUTION Caution denotes a hazard. It calls attention to a procedure that, if not correctly performed or adhered to, would result in damage to or destruction of the instrument. Do not proceed beyond a caution sign until the indicated conditions are fully understood and met.

How to Use This Guide

This guide uses the following conventions:

Front-Panel Key

This represents a key physically located on the instrument.

SOFTKEY

This represents a “softkey,” a key whose label is determined by the instrument’s firmware.

Screen Text

This represents text displayed on the instrument’s screen.

Documentation Map

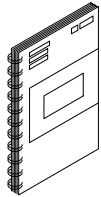

The *Installation and Quick Start Guide* provides procedures for installing, configuring, and verifying the operation of the analyzer. It also will help you familiarize yourself with the basic operation of the analyzer.

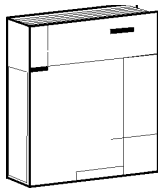

The *User's Guide* shows how to make measurements, explains commonly-used features, and tells you how to get the most performance from your analyzer.

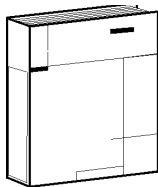

The *Reference Guide* provides reference information, such as specifications, menu maps, and key definitions.



The *Programmer's Guide* provides general GPIB programming information, a command reference, and example programs. The *Programmer's Guide* contains a CD-ROM with example programs.

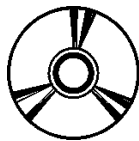

The **CD-ROM** provides the *Installation and Quick Start Guide*, the *User's Guide*, the *Reference Guide*, and the *Programmer's Guide* in PDF format for viewing or printing from a PC.



The *Service Guide* provides information on calibrating, troubleshooting, and servicing your analyzer. The *Service Guide* is not part of a standard shipment and is available only as Option 0BW, or by ordering part number 08720-90397. A CD-ROM with the *Service Guide* in PDF format is included for viewing or printing from a PC.

1. Making Measurements

Using This Chapter	1-2
More Instrument Functions Not Described in This Guide.....	1-3
Making a Basic Measurement.....	1-4
Step 1. Connect the device under test and any required test equipment.....	1-4
Step 2. Choose the measurement parameters.....	1-4
Step 3. Perform and apply the appropriate error-correction.....	1-5
Step 4. Measure the device under test.....	1-5
Step 5. Output the measurement results.....	1-6
Measuring Magnitude and Insertion Phase Response.....	1-7
Measuring the Magnitude Response.....	1-7
Measuring Insertion Phase Response.....	1-8
Using Display Functions.....	1-10
Titling the Active Channel Display.....	1-11
Viewing Both Primary Measurement Channels.....	1-12
Viewing Four Measurement Channels.....	1-14
Customizing the Four-Channel Display.....	1-17
Using Memory Traces and Memory Math Functions.....	1-19
Blanking the Display.....	1-20
Adjusting the Colors of the Display.....	1-22
Using Markers.....	1-24
To Use Continuous and Discrete Markers.....	1-24
To Activate Display Markers.....	1-25
To Move Marker Information Off the Grids.....	1-26
To Use Delta (Δ) Markers.....	1-28
To Activate a Fixed Marker.....	1-29
To Couple and Uncouple Display Markers.....	1-31
To Use Polar Format Markers.....	1-32
To Use Smith Chart Markers.....	1-33
To Set Measurement Parameters Using Markers.....	1-34
Setting the CW Frequency.....	1-38
To Search for a Specific Amplitude.....	1-39
To Calculate the Statistics of the Measurement Data.....	1-41
Measuring Electrical Length and Phase Distortion.....	1-43
Measuring Electrical Length.....	1-43
Measuring Phase Distortion.....	1-45
Characterizing a Duplexer (ES Analyzers Only).....	1-49
Definitions.....	1-49
Procedure.....	1-49
Measuring Amplifiers.....	1-52
Measuring Gain Compression.....	1-53
Measuring Gain and Reverse Isolation Simultaneously (ES Analyzers Only).....	1-57
Making High Power Measurements with Option 085 (ES Analyzers Only).....	1-59
Making High Power Measurements with Option 012 (ES Analyzers Only).....	1-65
Using the Swept List Mode to Test a Device.....	1-67
Connect the Device Under Test.....	1-67

Observe the Characteristics of the Filter	1-68
Choose the Measurement Parameters	1-68
Calibrate and Measure	1-70
Using Limit Lines to Test a Device	1-72
Setting Up the Measurement Parameters	1-72
Creating Flat Limit Lines	1-73
Creating a Sloping Limit Line	1-75
Creating Single Point Limits	1-77
Editing Limit Segments	1-78
Running a Limit Test	1-79
Offsetting Limit Lines	1-79
Using Ripple Limits to Test a Device	1-81
Setting Up the List of Ripple Limits to Test	1-81
Editing Ripple Test Limits	1-84
Running the Ripple Test	1-86
Using Bandwidth Limits to Test a Bandpass Filter	1-92
Setting Up Bandwidth Limits	1-92
Running a Bandwidth Test	1-94
Using Test Sequencing	1-98
How to Use Test Sequencing	1-98
Creating a Sequence	1-98
Running a Sequence	1-100
Stopping a Sequence	1-100
Editing a Sequence	1-100
Clearing a Sequence from Memory	1-102
Changing the Sequence Title	1-103
Naming Files Generated by a Sequence	1-103
Storing a Sequence on a Disk	1-104
Loading a Sequence from Disk	1-104
Purging a Sequence from Disk	1-104
Printing a Sequence	1-104
In-Depth Sequencing Information	1-105
Using Test Sequencing to Test a Device	1-114
Cascading Multiple Example Sequences	1-114
Loop Counter Example Sequence	1-115
Generating Files in a Loop Counter Example Sequence	1-116
Limit Test Example Sequence	1-118

2. Making Mixer Measurements

(Option 089 Only)

Using This Chapter	2-2
Mixer Measurement Capabilities	2-3
Measurement Considerations	2-4
Minimizing Source and Load Mismatches	2-4
Reducing the Effect of Spurious Responses	2-5
Eliminating Unwanted Mixing and Leakage Signals	2-5
How RF and IF Are Defined	2-7
Frequency Offset Mode Operation	2-9
LO Frequency Accuracy and Stability	2-10

Differences Between Internal and External R Channel Inputs	2-10
Power Meter Calibration	2-12
Conversion Loss Using the Frequency Offset Mode	2-13
Setting Measurement Parameters for the Power Meter Calibration	2-14
Performing a Power Meter (Source) Calibration Over the RF Range.....	2-15
Setting the Analyzer to Make an R Channel Measurement	2-17
High Dynamic Range Swept RF/IF Conversion Loss	2-20
Set Measurement Parameters for the IF Range	2-20
Perform a Power Meter Calibration Over the IF Range	2-20
Perform a Receiver Calibration Over the IF Range	2-22
Set the Analyzer to the RF Frequency Range	2-22
Perform a Power Meter Calibration Over the RF Range	2-23
Perform the High Dynamic Range Measurement	2-24
Fixed IF Mixer Measurements	2-27
Tuned Receiver Mode	2-27
Sequence 1 Setup	2-27
Sequence 2 Setup	2-32
Phase or Group Delay Measurements	2-35
Phase Measurements	2-35
Phase Linearity and Group Delay	2-35
Amplitude and Phase Tracking	2-39
Conversion Compression Using the Frequency Offset Mode	2-40
Isolation Example Measurements	2-45
LO to RF Isolation	2-45
RF Feedthrough	2-47
SWR / Return Loss	2-50
3. Making Time Domain Measurements	3-2
Using This Chapter	3-2
Introduction to Time Domain Measurements	3-3
Making Transmission Response Measurements	3-5
Making Reflection Response Measurements	3-9
Time Domain Bandpass Mode	3-12
Adjusting the Relative Velocity Factor	3-12
Reflection Measurements Using Bandpass Mode	3-12
Transmission Measurements Using Bandpass Mode	3-14
Time Domain Low Pass Mode	3-15
Setting the Frequency Range for Time Domain Low Pass	3-15
Reflection Measurements in Time Domain Low Pass	3-16
Fault Location Measurements Using Low Pass	3-17
Transmission Measurements in Time Domain Low Pass	3-18
Transforming CW Time Measurements into the Frequency Domain	3-21
Forward Transform Measurements	3-21
Masking	3-25
Windowing	3-26
Range	3-29
Resolution	3-31
Response Resolution	3-31
Range Resolution	3-33

Contents

Gating	3-34
Setting the Gate	3-34
Selecting Gate Shape	3-35

4. Printing, Plotting, and Saving

Measurement Results

Using This Chapter	4-2
Printing or Plotting Your Measurement Results	4-3
Configuring a Print Function	4-4
Defining a Print Function	4-6
If You Are Using a Color Printer	4-6
To Reset the Printing Parameters to Default Values	4-7
Printing One Measurement Per Page	4-8
Printing Multiple Measurements Per Page	4-9
Configuring a Plot Function	4-10
If You Are Plotting to an HPGL/2 Compatible Printer	4-10
If You Are Plotting to a Pen Plotter	4-11
If You Are Plotting Measurement Results to a Disk Drive	4-12
Defining a Plot Function	4-15
Choosing Display Elements	4-15
Selecting Auto-Feed	4-15
Selecting Pen Numbers and Colors	4-16
Selecting Line Types	4-16
Choosing Scale	4-17
Choosing Plot Speed	4-18
To Reset the Plotting Parameters to Default Values	4-18
Plotting One Measurement Per Page Using a Pen Plotter	4-19
Plotting Multiple Measurements Per Page Using a Pen Plotter	4-20
If You Are Plotting to an HPGL Compatible Printer	4-21
To View Plot Files on a PC	4-22
Using Ami Pro	4-22
Using Freelance	4-23
Converting HPGL Files for Use with Other PC Applications	4-23
Outputting Plot Files from a PC to a Plotter	4-24
Outputting Plot Files from a PC to an HPGL Compatible Printer	4-25
Step 1. Store the HPGL initialization sequence.	4-25
Step 2. Store the exit HPGL mode and form feed sequence.	4-26
Step 3. Send the HPGL initialization sequence to the printer.	4-26
Step 4. Send the plot file to the printer.	4-26
Step 5. Send the exit HPGL mode and form feed sequence to the printer.	4-26
Outputting Single Page Plots Using a Printer	4-26
Outputting Multiple Plots to a Single Page Using a Printer	4-27
Plotting Multiple Measurements Per Page from Disk	4-28
To Plot Multiple Measurements on a Full Page	4-29
To Plot Measurements in Page Quadrants	4-30
Titling the Displayed Measurement	4-32
Configuring the Analyzer to Produce a Time Stamp	4-33
Aborting a Print or Plot Process	4-33
Printing or Plotting the List Values or Operating Parameters	4-34

Contents

If You Want a Single Page of Values	4-34
If You Want the Entire List of Values	4-34
Solving Problems with Printing or Plotting	4-35
Saving and Recalling Instrument States	4-36
Places Where You Can Save	4-36
What You Can Save to the Analyzer's Internal Memory	4-36
What You Can Save to a Floppy Disk	4-37
What You Can Save to a Computer	4-37
Saving an Instrument State	4-38
Saving Measurement Results	4-39
ASCII Data Formats	4-41
Saving in Textual (CSV) Form	4-44
Saving in Graphical (JPEG) Form	4-46
Instrument State Files	4-47
Saving Time Gated Frequency Data	4-49
Differences between Raw, Data, and Format Arrays	4-49
Re-Saving an Instrument State	4-51
Deleting a File	4-52
To Delete an Instrument State File	4-52
To Delete all Files	4-52
Renaming a File	4-53
Recalling a File	4-54
Formatting a Disk	4-54
Solving Problems with Saving or Recalling Files	4-55
If You Are Using an External Disk Drive	4-55

5. Optimizing Measurement Results

Using This Chapter	5-2
Taking Care of Microwave Connectors	5-3
Increasing Measurement Accuracy	5-4
Interconnecting Cables	5-4
Improper Calibration Techniques	5-4
Sweeping Too Fast for Electrically Long Devices	5-4
Connector Repeatability	5-4
Temperature Drift	5-4
Frequency Drift	5-5
Performance Verification	5-5
Reference Plane and Port Extensions	5-5
Maintaining Test Port Output Power During Sweep Retrace	5-7
Making Accurate Measurements of Electrically Long Devices	5-8
The Cause of Measurement Problems	5-8
To Improve Measurement Results	5-8
Increasing Sweep Speed	5-10
To Use Swept List Mode	5-10
To Decrease the Frequency Span	5-11
To Set the Auto Sweep Time Mode	5-11
To Widen the System Bandwidth	5-12
To Reduce the Averaging Factor	5-12
To Reduce the Number of Measurement Points	5-12

To Set the Sweep Type	5-12
To View a Single Measurement Channel	5-12
To Activate Chop Sweep Mode	5-13
To Use External Calibration	5-13
To Use Fast 2-Port Calibration (ES Analyzers Only)	5-13
Increasing Dynamic Range	5-15
Increase the Test Port Input Power	5-15
Reduce the Receiver Noise Floor	5-15
Reduce the Receiver Crosstalk	5-15
Reducing Noise	5-16
To Activate Averaging	5-16
To Change System Bandwidth	5-16
To Use Direct Sampler Access Configurations (Option 012 Only)	5-17
Reducing Receiver Crosstalk	5-18
Reducing Recall Time	5-18

6. Calibrating for Increased Measurement Accuracy

How to Use This Chapter	6-2
Introduction	6-3
Calibration Considerations	6-4
Measurement Parameters	6-4
Device Measurements	6-4
Clarifying Type-N Connector Sex	6-4
Omitting Isolation Calibration	6-4
Saving Calibration Data	6-5
Restarting a Calibration	6-5
The Calibration Standards	6-5
Frequency Response of Calibration Standards	6-6
Interpolated Error Correction	6-8
Error-Correction Stimulus State	6-9
Procedures for Error Correcting Your Measurements	6-10
Types of Error Correction	6-10
Frequency Response Error Corrections	6-12
Response Error Correction for Reflection Measurements	6-12
Response Error Correction for Transmission Measurements	6-14
Receiver Calibration	6-15
Frequency Response and Isolation Error Corrections	6-17
Response and Isolation Error Correction for Transmission Measurements	6-17
Response and Isolation Error Correction for Reflection Measurements	6-19
Enhanced Frequency Response Error Correction	6-22
Enhanced Reflection Calibration	6-25
One-Port Reflection Error Correction	6-26
Full Two-Port Error Correction (ES Analyzers Only)	6-29
Power Meter Measurement Calibration	6-33
Loss of Power Meter Calibration Data	6-33
Interpolation in Power Meter Calibration	6-33
Entering the Power Sensor Calibration Data	6-34
Compensating for Directional Coupler Response	6-35

Contents

Using Sample-and-Sweep Correction Mode	6-36
Using Continuous Correction Mode	6-37
Calibrating for Noninsertable Devices	6-40
Adapter Removal Calibration (ES Analyzers Only)	6-41
Perform the 2-Port Error Corrections	6-42
Verify the Results	6-45
Matched Adapters	6-45
Modify the Cal Kit Thru Definition	6-46
Minimizing Error When Using Adapters	6-47
Making Non-Coaxial Measurements	6-48
Fixtures	6-48
Calibrating for Non-Coaxial Devices (ES Analyzers Only)	6-50
TRL Error Correction	6-50
LRM Error Correction	6-53
Create a User-Defined LRM Calibration Kit	6-53
Perform the LRM Calibration	6-55
Calibrating Using Electronic Calibration (ECal)	6-57
Set Up the Measurement	6-57
Connect the ECal Equipment	6-58
Select the ECal Options	6-59
Perform the Calibration	6-61
Display the Module Information	6-63
Perform the Confidence Check	6-64
Investigating the Calibration Results Using the ECal Service Menu	6-66
Adapter Removal Using ECal (ES Analyzers Only)	6-68
Perform the 2-Port Error Corrections	6-70
Determine the Electrical Delay	6-72
Remove the Adapter	6-73
Verify the Results	6-74

7. Operating Concepts

Using This Chapter	7-2
Where to Find More Information	7-2
System Operation	7-3
The Built-In Synthesized Source	7-3
The Built-In Test Set	7-4
The Receiver Block	7-4
The Microprocessor	7-4
Required Peripheral Equipment	7-4
Processing	7-5
Processing Details	7-6
Output Power	7-9
Understanding the Power Ranges	7-9
Power Coupling Options	7-10
Sweep Time	7-11
Manual Sweep Time Mode	7-11
Auto Sweep Time Mode	7-11
Minimum Sweep Time	7-11
Source Attenuator Switch Protection	7-13

Contents

Allowing Repetitive Switching of the Attenuator	7-13
Channel Stimulus Coupling	7-14
Sweep Types	7-15
Linear Frequency Sweep (Hz)	7-15
Logarithmic Frequency Sweep (Hz)	7-15
Stepped List Frequency Sweep (Hz)	7-15
Swept List Frequency Sweep (Hz)	7-17
Power Sweep (dBm)	7-19
CW Time Sweep (Seconds)	7-19
Selecting Sweep Modes	7-19
S-Parameters	7-20
Understanding S-Parameters	7-20
The S-Parameter Menu	7-22
Analyzer Display Formats	7-24
Log Magnitude Format	7-24
Phase Format	7-24
Group Delay Format	7-25
Smith Chart Format	7-26
Polar Format	7-27
Linear Magnitude Format	7-27
SWR Format	7-28
Real Format	7-29
Imaginary Format	7-29
Group Delay Principles	7-29
Electrical Delay	7-33
Noise Reduction Techniques	7-34
Averaging	7-34
Smoothing	7-35
IF Bandwidth Reduction	7-35
Measurement Calibration	7-37
What Is Accuracy Enhancement?	7-37
What Causes Measurement Errors?	7-37
Characterizing Microwave Systematic Errors	7-41
How Effective Is Accuracy Enhancement?	7-51
Calibration Routines	7-54
Response Calibration	7-54
Response and Isolation Calibration	7-54
Enhanced Response Calibration	7-54
S11 and S22 One-Port Calibration	7-55
Full Two-Port Calibration (ES Models Only)	7-55
TRL*/LRM* Two-Port Calibration	7-55
E-CAL	7-56
Modifying Calibration Kits	7-57
Definitions	7-57
Procedure	7-58
Modify Calibration Kit Menu	7-58
Verify Performance	7-65
Saving Modified Calibration Kits to a Disk	7-65
Modifying and Saving a Calibration Kit from the Calibration Kit Selection Menu	7-65

Contents

TRL*/LRM* Calibration (ES Models Only)	7-66
Why Use TRL Calibration?	7-66
TRL Terminology	7-66
How TRL*/LRM* Calibration Works	7-67
Improving Raw Source Match and Load Match for TRL*/LRM* Calibration	7-69
How True TRL/LRM Works (Option 400 Only)	7-70
The TRL Calibration Procedure	7-70
GPIB Operation	7-76
Key	7-76
GPIB STATUS Indicators	7-77
System Controller Mode	7-77
Talker/Listener Mode	7-77
Pass Control Mode	7-77
Address Menu	7-78
Using the Parallel Port	7-78
Limit Line Operation	7-80
Edit Limits Menu	7-81
Edit Segment Menu	7-81
Offset Limits Menu	7-81
Knowing the Instrument Modes	7-82
Network Analyzer Mode	7-82
Tuned Receiver Mode	7-82
Frequency Offset Operation (Option 089)	7-83
8. Safety and Regulatory Information	
General Information	8-2
Maintenance	8-2
Assistance	8-2
Shipment for Service	8-2
Safety Symbols	8-4
Instrument Markings	8-4
Safety Considerations	8-5
Safety Earth Ground	8-5
Before Applying Power	8-5
Servicing	8-6
General	8-7
Compliance with German FTZ Emissions Requirements	8-8
Compliance with German Noise Requirements	8-8
Compliance with Canadian EMC Requirements	8-8
Declaration of Conformity	8-9

1 Making Measurements

Using This Chapter

This chapter contains the following example procedures for making measurements. Mixer and time domain measurements are covered in [Chapter 2](#), "Making Mixer Measurements (Option 089 Only)" and [Chapter 3](#), "Making Time Domain Measurements." This chapter also describes how to use most display, marker, and sequencing functions.

- ["Making a Basic Measurement" on page 1-4](#)
- ["Measuring Magnitude and Insertion Phase Response" on page 1-7](#)
- ["Measuring Electrical Length and Phase Distortion" on page 1-43](#)
 - Electrical Length
 - Phase Distortion (deviation from linear phase, group delay)
- Characterizing a Duplexer (ES Analyzers Only)
- ["Measuring Amplifiers" on page 1-52](#)
 - Measuring Gain Compression
 - Measuring Gain Compression and Reverse Isolation Simultaneously (ES Analyzers Only)
 - Making High Power Measurements (ES Analyzers Only)
- ["Using the Swept List Mode to Test a Device" on page 1-67](#)
- ["Using Limit Lines to Test a Device" on page 1-72](#)
- ["Using Test Sequencing to Test a Device" on page 1-114](#)

The following chapters describe how to use more instrument functions (as indicated by their chapter titles):

- [Chapter 4](#), "Printing, Plotting, and Saving Measurement Results"
- [Chapter 5](#), "Optimizing Measurement Results"
- [Chapter 6](#), "Calibrating for Increased Measurement Accuracy"

More Instrument Functions Not Described in This Guide

To learn about instrument functions not covered in this user's guide, refer to the following chapters in the reference guide.

- | | |
|-----------------------------|--|
| "Menu Maps" | contains maps of the instrument menu structure. |
| "Hardkey/Softkey Reference" | contains descriptions of all instrument functions. |

Making a Basic Measurement

There are five basic steps when you are making a measurement.

1. Connect the device under test and any required test equipment.

CAUTION Damage may result to the device under test (DUT) if it is sensitive to the analyzer's default output power level. To avoid damaging a sensitive DUT, be sure to lower the output power before connecting the DUT to the analyzer.

2. Choose the measurement parameters.
3. Perform and apply the appropriate error-correction.
4. Measure the device under test (DUT).
5. Output the measurement results.

This example procedure shows you how to measure the transmission response of a bandpass filter.

Step 1. Connect the device under test and any required test equipment.

Make the connections as shown in [Figure 1-1](#).

Figure 1-1 Basic Measurement Setup

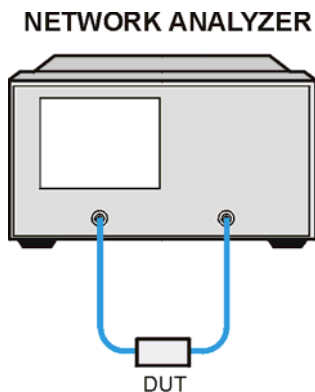

pa52e

Step 2. Choose the measurement parameters.

Press **Preset**.

To set preset the analyzer to the "Factory Preset" conditions, press the **PRESET: FACTORY** softkey if it is not selected. Then press **Preset**.

Setting the Frequency Range

To set the center frequency to 134 MHz, press:

Center **134** **M/μ**

To set the span to 30 MHz, press:

Span **30** **M/μ**

NOTE You could also press the **Start** and **Stop** keys and enter the frequency range limits as start frequency and stop frequency values.

Setting the Source Power

To change the power level to -5 dBm, press:

Power **-5** **x1**

NOTE You could also press **POWER RANGE MAN** **POWER RANGES** and select one of the power ranges to keep the power setting within the defined range.

Setting the Measurement

To change the number of measurement data points to 101, press:

Sweep Setup **NUMBER OF POINTS** 

To select the transmission measurement, press:

Meas **Trans: FWD S21 (B/R)** or on ET models: **TRANSMISSN**

To view the data trace, press:

Scale Ref **AUTOSCALE**

Step 3. Perform and apply the appropriate error-correction.

Refer to the [Chapter 5, "Optimizing Measurement Results,"](#) for procedures on correcting measurement errors.

To save the instrument state and error-correction in the analyzer internal memory, press:

Save/Recall **SELECT DISK** **INTERNAL MEMORY** **RETURN** **SAVE STATE**

Step 4. Measure the device under test.

Replace any standard used for error-correction with the device under test.

To measure the insertion loss of the bandpass filter, press:

Marker Search **SEARCH: MAX**

Step 5. Output the measurement results.

To create a printed copy of the measurement results, press:

PRINT MONOCHROME (or **PLOT**)

Refer to [Chapter 4](#) , "Printing, Plotting, and Saving Measurement Results," for procedures on how to set up a printer and define a print, plot, or save results.

Measuring Magnitude and Insertion Phase Response

This measurement example shows you how to measure the maximum amplitude of a surface acoustic wave (SAW) filter and then how to view the measurement data in the phase format, which provides information about the phase response.

Measuring the Magnitude Response

1. Connect your test device as shown in [Figure 1-2](#).

Figure 1-2 Device Connections for Measuring a Magnitude Response

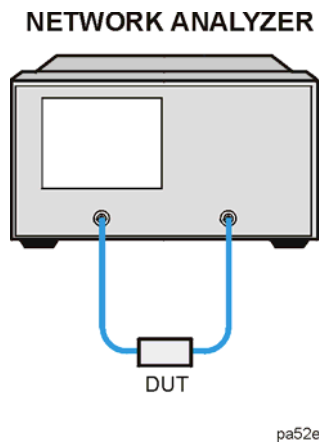

2. Press **Preset** and choose the measurement settings. For this example the measurement parameters are set as follows:

Meas **Trans:FWD S21 (B/R)** or on ET models: **TRANSMISSN**
Center **134** **M/μ**
Span **50** **M/μ**
Power **-3** **x1**
Scale Ref **AUTO SCALE**
Chan 2
Meas **Trans:FWD S21 (B/R)** or on ET models: **TRANSMISSN**
Scale Ref **AUTO SCALE**

You may also want to select settings for the number of data points, averaging, and IF bandwidth.

3. Remove the device and connect the power cables together (thru) and perform a response calibration using the following key presses.

Press **Chan 1** **Cal** **CALIBRATE MENU** **RESPONSE** **THRU**.

If the channels are coupled (the default condition), this calibration is valid for both channels.

Making Measurements

Measuring Magnitude and Insertion Phase Response

4. Reconnect your test device.
5. To better view the measurement trace, press:

Scale Ref **AUTO SCALE**

6. To locate the maximum amplitude of the device response, as shown in [Figure 1-3](#), press:

Marker Search **SEARCH: MAX**

Figure 1-3 Example Magnitude Response Measurement Results

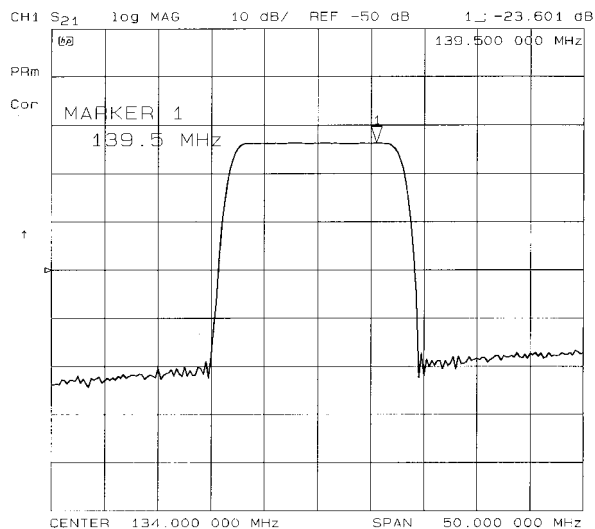

pa5106e

Measuring Insertion Phase Response

7. To view both the magnitude and phase response of the device, as shown in [Figure 1-4](#), press:

Chan 2

Display **DUAL | QUAD SETUP** **DUAL CHAN ON**

Format **PHASE**

The channel 2 portion of [Figure 1-4](#) shows the insertion phase response of the device under test. The analyzer measures and displays phase over the range of -180° to $+180^\circ$. As phase changes beyond these values, a sharp 360° transition occurs in the displayed data.

Figure 1-4 Example Insertion Phase Response Measurement

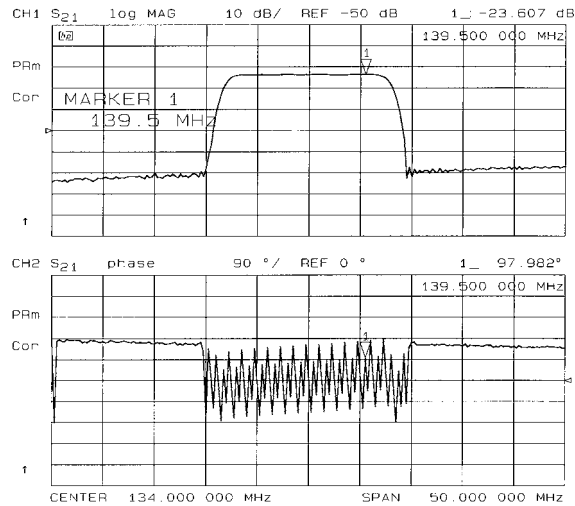

pa5107e

The phase response shown in Figure 1-5 is undersampled; that is, there is more than 180° phase delay between frequency points. If the $\Delta\Phi \geq 180^\circ$, incorrect phase and delay information may result. Figure 1-6 shows an example of phase samples being with $\Delta\Phi$ less than 180° and greater than 180°.

Figure 1-5 Phase Samples

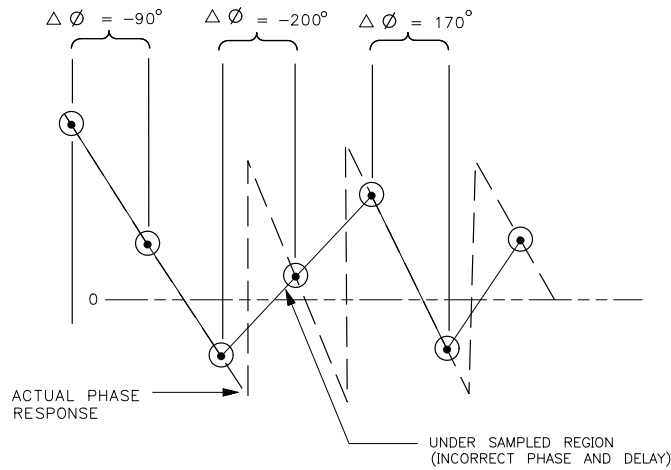

pb6125d

Undersampling may arise when measuring devices with long electrical length. To correct this problem, the frequency span should be reduced, or the number of points increased until $\Delta\Phi$ is less than 180° per point. Electrical delay may also be used to compensate for this effect (as shown in the next example procedure).

Using Display Functions

This section provides the necessary information for using the display functions. These functions are very helpful for displaying measurement data so that it will be easy to read. This section covers the following topics:

- Adding titles to your measurements
- Viewing both primary channels at the same time
- Viewing and customizing four-channel measurements
- Using the memory traces
- Using the memory math functions
- Blanking the analyzer's display
- Changing the colors of the display

Titling the Active Channel Display

1. Press **Display** **MORE** **TITLE** to access the title menu.
2. Press **ERASE TITLE** and enter the title you want for your measurement display.
 - If you have a DIN keyboard attached to the analyzer, type the title you want from the keyboard. Then press **ENTER** to enter the title into the analyzer. You can enter a title that has a maximum of 50 characters. (For more information on using a keyboard with the analyzer, refer to the “Options and Accessories” chapter in the reference guide.)
 - If you do not have a DIN keyboard attached to the analyzer, enter the title from the analyzer front panel.
 - a. Turn the front panel knob to move the arrow pointer to the first character of the title.
 - b. Press **SELECT LETTER**.
 - c. Repeat the previous two steps to enter the rest of the characters in your title. You can enter a title that has a maximum of 50 characters.
 - d. Press **DONE** to complete the title entry.

Figure 1-6 Example of a Display Title

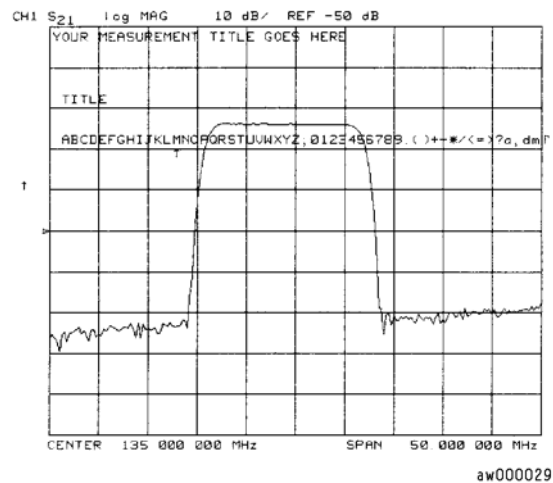

CAUTION The **NEWLINE** and **FORMFEED** keys are not intended for creating display titles. Those keys are for creating commands to send to peripherals during a sequence program.

Viewing Both Primary Measurement Channels

In some cases, you may want to view more than one measured parameter at a time. Simultaneous gain and phase measurements, for example, are useful in evaluating stability in negative feedback amplifiers. You can easily make such measurements using the dual channel display.

1. To see channels 1 and 2 in the same grid, press:

Display **DUAL | QUAD SETUP**, set **DUAL CHAN on OFF** to ON, and **SPLIT DISP** to 1X.

Figure 1-7 Example of Viewing Channel 1 and 2 Simultaneously

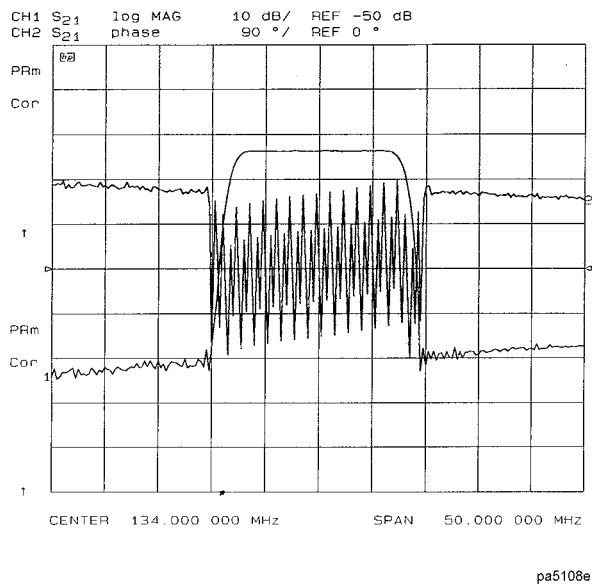

2. To view the measurements on separate graticules, press: Set **SPLIT DISP** to 2X. The analyzer shows channel 1 on the upper half of the display and channel 2 on the lower half of the display. The analyzer defaults to measuring S₁₁ on channel 1 and S₂₁ on channel 2.

Figure 1-8 Example Dual Channel with Split Display On

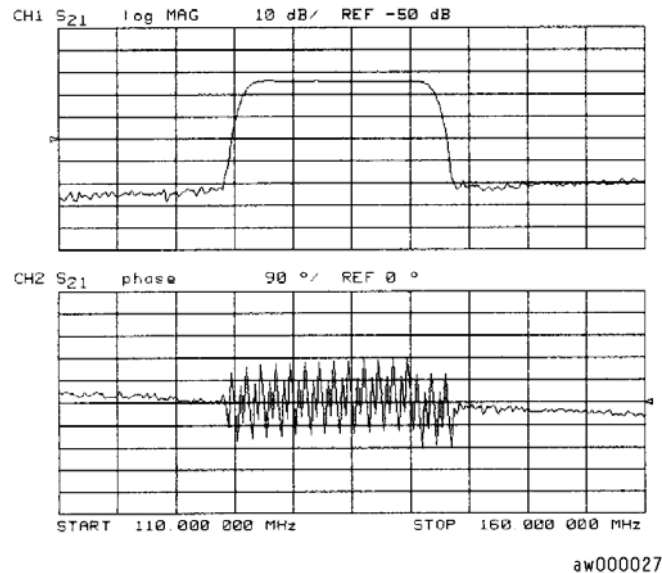

- To return to a single-graticule display, press: **SPLIT DISPLAY 1X**.

NOTE You can control the stimulus functions of the two channels independent of each other by pressing **Sweep Setup** **COUPLED CH OFF**.

Dual Channel Mode with Decoupled Stimulus

The stimulus functions of the two channels can be controlled independently using **COUPLED CH ON off** in the stimulus menu. In addition, the markers can be controlled independently for each channel using **MARKERS: UNCOUPLED** in the marker mode menu, under the **Marker Fctn** key.

NOTE ES models only: For dual channel, if channels are uncoupled and you have full 2-port calibrations on both channels, you will not be able to select a non-ratioed measurement. For example, you can measure S_{21} or B/R, but not input B.

NOTE Auxiliary channels 3 and 4 are permanently coupled by stimulus to primary channels 1 and 2, respectively. Decoupling the primary channels' stimulus from each other does not affect the stimulus coupling between the auxiliary channels and their primary channels.

Dual Channel Mode with Decoupled Channel Power

By decoupling the channel power or port power and using the dual channel mode, you can simultaneously view two measurements (or two sets of measurements, if both auxiliary channels are enabled) having different power levels.

However, there are two configurations that will not sweep continuously.

Making Measurements

Using Display Functions

1. For analyzers with source attenuators, with channel 1 having one attenuation value and channel 2 set to a different attenuation value, then continuous sweep is disabled to avoid wear on the attenuator. A similar situation where this occurs is when a 2-port cal is active and the port 1 attenuation value is not equal to the port 2 attenuation value. Since one attenuator is used for both measurements, this would cause the attenuator to continuously switch power ranges, so continuous sweep is not allowed. (The exception is analyzers configured with option 400. Option 400 analyzers have two attenuators and can allow different attenuation settings on each port.)
2. For ES analyzers with Option 007 or 085 (options using a mechanical transfer switch), channel 1 is driving one test port and channel 2 is driving the other test port. This would cause the test port transfer switch to continually cycle. The instrument will not allow the transfer switch or attenuator to continuously switch ranges in order to update these measurements without the direct intervention of the operator.

If one of these conditions exist, the test set hold mode will engage, and the status notation t_{SH} will appear on the left side of the screen. The hold mode leaves the measurement function in only one of the two measurements. To update both measurement setups, press **Format** **MEASURE RESTART**. Refer to "Source Attenuator Switch Protection" on page 7-13.

Viewing Four Measurement Channels

Four measurement channels can be viewed simultaneously by enabling auxiliary channels 3 and 4. Although independent of other channels in most variables, channels 3 and 4 are permanently coupled to channels 1 and 2 respectively by stimulus. That is, if channel 1 is set for a center frequency of 200 MHz and a span of 50 MHz, channel 3 will have the same stimulus values.

NOTE Channels 1 and 2 are referred to as primary channels and channels 3 and 4 are referred to as auxiliary channels.

Channel 3 or 4 are activated when the Chan 3 or Chan 4 keys are pressed. Alternatively, you can enable the auxiliary setting **AUX CHAN** to ON. For example, if channel 1 is active, pressing **AUX CHAN** to ON enables channel 3 and its trace appears on the display. Channel 4 is similarly enabled and viewed when channel 2 is active.

1. Press **Format** to select the type of display of the data. This example uses the log mag format.
2. If channel 1 is not active, make it active by pressing **Chan 1**.
3. Press **Display** **DUAL | QUAD SETUP**, set **DUAL CHAN** to ON, set **AUX CHAN** to ON, and set **SPLIT DISP** to **4X**.

The display will appear as shown in [Figure 1-9](#). Channel 1 is in the upper-left quadrant of the display, channel 2 is in the upper-right quadrant, and channel 3 is in the lower half of the display.

Figure 1-9 Three-Channel Display

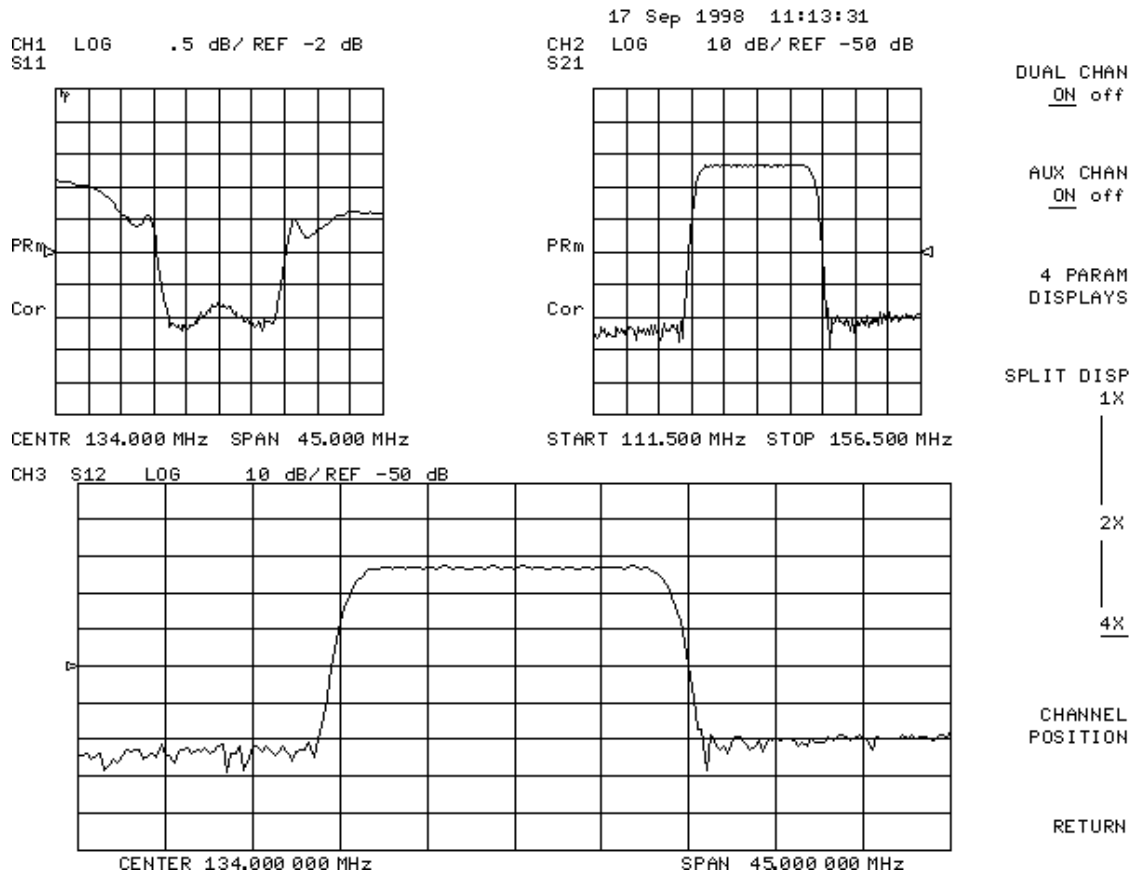

4. Press Chan 4 (or press **Chan 2**), set **AUX CHAN** to ON).

This enables channel 4 and the screen now displays four separate grids as shown in [Figure 1-10](#). Channel 4 is in the lower-right quadrant of the screen.

Making Measurements
Using Display Functions

Figure 1-10 Four-Channel Display

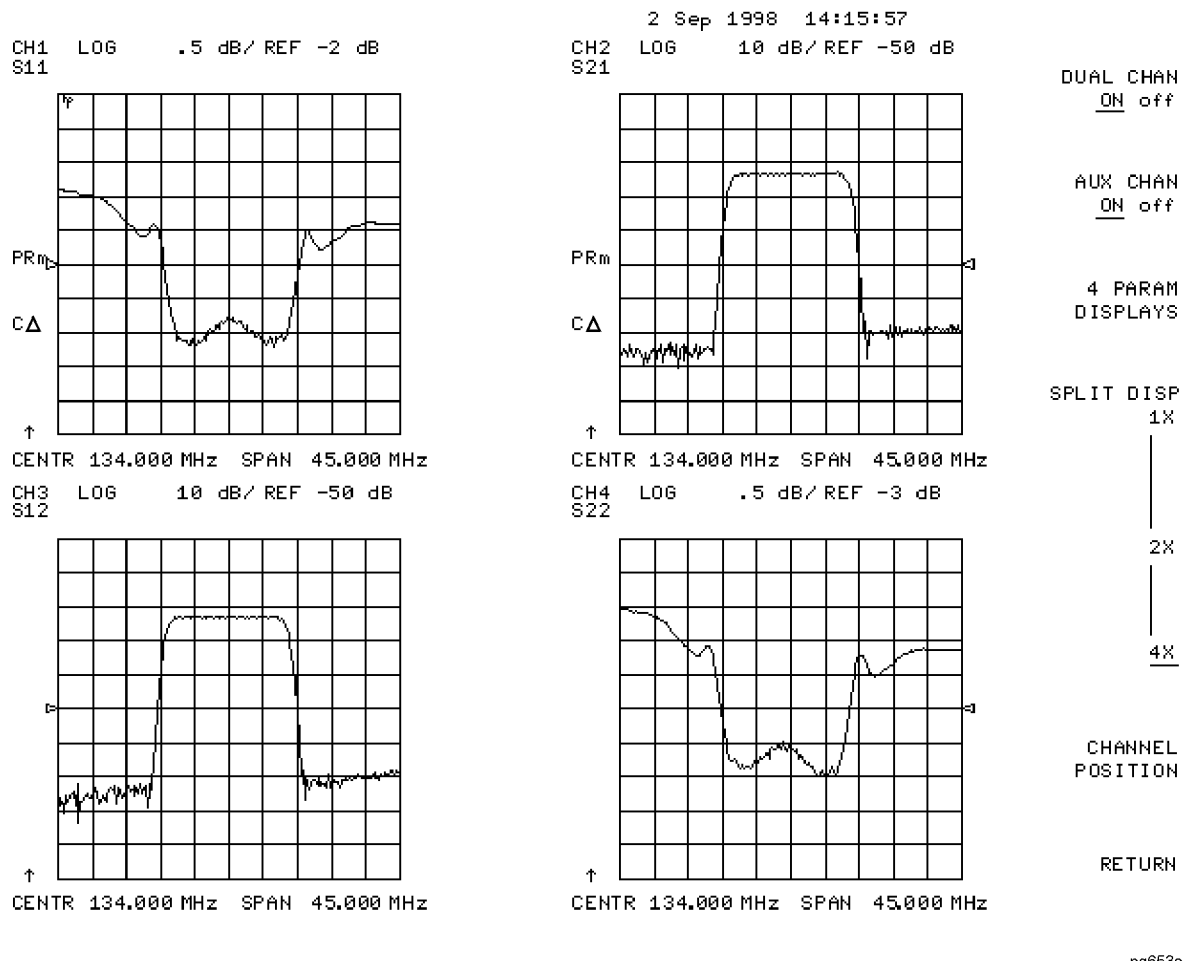

5. Press **Chan 4**.

Observe that the amber LED adjacent to the **Chan 4** key is lit and the CH4 indicator on the display has a box around it. This indicates that channel 4 is now active and can be configured.

6. Press **Marker** **MARKER 1** **MARKER 2**.

Markers 1 and 2 appear on all four channel traces. Rotating the front panel control knob moves marker 2 on all four channel traces. Note that the active function, in this case the marker frequency, is the same color and in the same grid as the active channel (channel 4).

7. Press **Chan 3**.

Observe that the amber LED adjacent to the **Chan 3** key is lit. This indicates that channel 3 is now active and can be configured.

8. Rotate the front panel control knob and notice that marker 2 still moves on all four channel traces.

9. To independently control the channel markers:

Press **Marker Fctn** **MARKER MODE MENU**, set **MARKERS:** to UNCOUPLED.

Rotate the front panel control knob. Marker 2 moves only on the channel 3 trace.

Once made active, a channel can be configured independently of the other channels in most variables except stimulus. For example, once channel 3 is active, you can change its format to a Smith chart by

pressing **Format** **SMITH CHART** .

Customizing the Four-Channel Display

When one or both auxiliary channels are enabled, **DUAL CHAN on OFF** and **SPLIT DISP 1X 2X 4X** interact to produce different display configurations according to [Table 1-1](#).

Table 1-1 Customizing the Display

Split Display	Dual Channel	Aux Channels On	Number of Graticules
1X	Don't Care	Don't Care	1
1X/2X/4X	Off	None	
2X/4X	Off	3 or 4	2
2X	On	Don't Care	
4X	On	3 or 4	3
4X	On	Both on	4

Channel Position Softkey

CHANNEL POSITION gives you options for arranging the display of the channels. Press **Display**, **DUAL | QUAD SETUP** to use **CHANNEL POSITION** .

CHANNEL POSITION works with **SPLIT DISP 1X 2X 4X** . When **SPLIT DISP 2X** is selected, **CHANNEL POSITION** gives you two choices for a two-graticule display:

- Channels 1 and 2 overlaid in the top graticule, and channels 3 and 4 are overlaid in the bottom graticule.
- Channels 1 and 3 are overlaid in the top graticule, and channels 2 and 4 are overlaid in the bottom graticule.

When **SPLIT DISP 4X** is selected, **CHANNEL POSITION** gives you two choices for a four-graticule display:

- Channels 1 and 2 are in separate graticules in the upper half of the display, channels 3 and 4 are in separate graticules in the lower half of the display.
- Channels 1 and 3 are in the upper half of the display, channels 2 and 4 are in the lower half of the display.

4 Param Displays Softkey

The **4 PARAM DISPLAYS** menu does two things:

- provides a quick way to set up a four-parameter display
- gives information for using softkeys in the **Display** menu

Figure 1-11 shows the first **4 PARAM DISPLAYS** screen. Six setup options are described with softkeys **SETUP A** through **SETUP F**. **SETUP A** is a four-parameter display where each channel is displayed on its own grid. Pressing **SETUP A** immediately produces a four-grid, four-parameter display. **SETUP B** is also a four-parameter display, except that channel 1 and channel 2 are overlaid on the upper grid and channel 3 and channel 4 are overlaid on the lower grid. The other setup softkeys operate similarly. Notice that setups D and F produce displays which include Smith charts.

Pressing **TUTORIAL** opens a screen which lists the order of keystrokes you would have to enter in order to create some of the setups without using one of the setup softkeys. The keystroke entries are listed (from top to bottom) beneath each setup and are color-coded to show the relationship between the keys and the channels. For example, beneath the four-grid display, [CHAN 1] and [MEAS] S11 are shown in yellow. Notice that in the four-grid graphic, Ch1 is also yellow, indicating that the keys in yellow apply to channel 1.

Pressing **MORE HELP** opens a screen which lists the hardkeys and softkeys associated with the auxiliary channels and setting up multiple-channel, multiple-grid displays. Next to each key is a description of its function.

Figure 1-11 4 Param Displays Menu

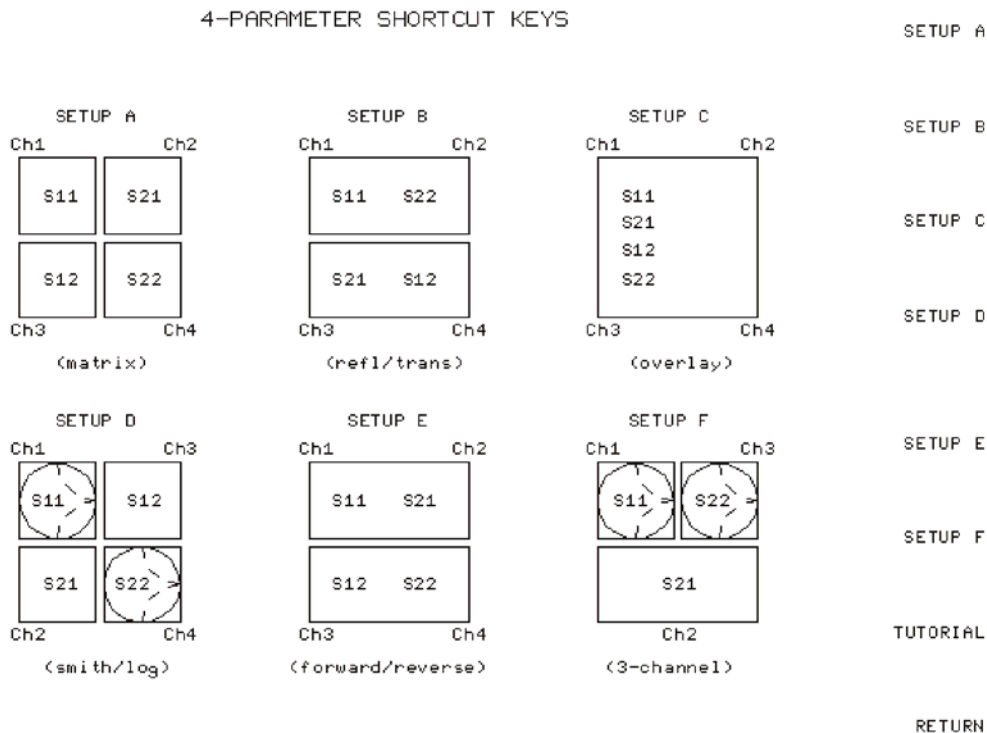

Using Memory Traces and Memory Math Functions

The analyzer has four available memory traces, one per channel. Memory traces are totally channel dependent: channel 1 cannot access the channel 2 memory trace or vice versa. Memory traces can be saved with instrument states: one memory trace can be saved per channel for each saved instrument state. There are up to 31 save/recall registers available, so the total number of memory traces that can be present is 128 including the four active for the current instrument state. The memory data is stored as full precision, complex data. Memory traces must be displayed in order to be saved with instrument states.

Additional data can be stored onto 3.5-inch floppy disks using the front panel disk drive.

NOTE You may not be able to store 31 instrument states if they include a large amount of calibration data. The calibration data contributes considerably to the size of the instrument state file and therefore the available memory may be full prior to filling all 31 registers.

Two trace math operations are implemented:

- **DATA/MEM** (data/memory)
- **DATA-MEM** (data–memory)

(Note that normalization is **DATA/MEM** not **DATA-MEM**.) Memory traces are saved and recalled and trace math is done immediately after error-correction. This means that any data processing done after error-correction, including parameter conversion, time domain transformation (Option 010), scaling, etc., can be performed on the memory trace. You can also use trace math as a simple means of error-correction, although that is not its main purpose.

All data processing operations that occur after trace math, except smoothing and gating, are identical for the data trace and the memory trace. If smoothing or gating is on when a memory trace is saved, this state is maintained regardless of the data trace smoothing or gating status. If a memory trace is saved with gating or smoothing on, these features can be turned on or off in the memory-only display mode.

The actual memory for storing a memory trace is allocated only as needed. The memory trace is cleared on instrument preset, power on, or instrument state recall.

If sweep mode or sweep range is different between the data and memory traces, trace math is allowed, and no warning message is displayed. If the number of points in the two traces is different, the memory trace is not displayed nor rescaled. However, if the number of points for the data trace is changed back to the number of points in the memory, the memory trace can then be displayed.

If trace math or display memory is requested and no memory trace exists, the message **CAUTION: NO VALID MEMORY TRACE** is displayed.

To Save a Data Trace to the Display Memory

Press **(Display) DATA→MEMORY** to store the current active measurement data in the memory of the active channel. The data trace is now also the memory trace. You can use a memory trace for subsequent math manipulations.

To View the Measurement Data and Memory Trace

The analyzer default setting shows you the current measurement data for the active channel.

1. To view a data trace that you have already stored to the active channel memory, press:

Making Measurements

Using Display Functions

Display **MEMORY**

This is the only memory display mode where you can change the smoothing and gating of the memory trace.

2. To view both the memory trace and the current measurement data trace, press:

Display **DATA and MEMORY**

To Divide Measurement Data by the Memory Trace

You can use this feature for ratio comparison of two traces, for example, measurements of gain or attenuation.

1. You must have already stored a data trace to the active channel memory, as described in ["To Save a Data Trace to the Display Memory" on page 1-19](#).
2. Press **Display** **DATA/MEM** to divide the data by the memory.

The analyzer normalizes the data to the memory, and shows the results.

To Subtract the Memory Trace from the Measurement Data Trace

You can use this feature for storing a measured vector error, for example, directivity. Then, you can later subtract it from the device measurement.

1. You must have already stored a data trace to the active channel memory, as described in ["To Save a Data Trace to the Display Memory" on page 1-19](#).
2. Press **Display** **DATA-MEM** to subtract the memory from the measurement data.

The analyzer performs a vector subtraction on the complex data.

To Ratio Measurements in Channel 1 and 2

You may want to use this feature when making amplifier measurements to produce a trace that represents gain compression. For example, with the channels uncoupled, you can increase the power for channel 2 while channel 1 remains unchanged. This will allow you to observe the gain compression on channel 2.

1. Press **Sweep Setup** **COUPLED CH OFF** to uncouple the channels.
2. Make sure that both channels must have the same number of points.
3. Press **Display** **MORE** **D2/D1 TO D2 ON** to ratio channels 1 and 2, and put the results in the channel 2 data array. This ratio is applied to the complex data.
4. Refer to ["Measuring Gain Compression" on page 1-53](#) for the procedure to identify the 1 dB compression point.

Blanking the Display

Pressing **Display** **ADJUST DISPLAY** **BLANK DISPLAY** switches off the analyzer display while leaving the instrument in its current measurement state. This feature may be helpful in prolonging the life of the LCD in applications where the analyzer is left unattended (such as in an automated test system). Turning the front panel knob or pressing any front panel key will restore normal display operation.

Pressing **Display** **FREQUENCY BLANK** will blank the displayed frequency notation for security

purposes. The frequency labels cannot be restored except by instrument preset or turning the power off and then on.

Adjusting the Colors of the Display

Setting Display Intensity

To adjust the intensity of the display, press **Display** **ADJUST DISPLAY** **INTENSITY** and rotate the front panel knob, use the **(Home)** **(Left/Right)** keys, or use the numerical keypad to set the intensity value between 50 and 100 percent. Lowering the intensity may prolong the life of the LCD.

Setting Default Colors

To set all the display elements to the factory-defined default colors, press **DEFAULT COLORS**.

NOTE **Preset** does not reset or change colors to the default color values. However, cycling power to the instrument will reset the colors to the default color values.

The Modify Colors Menu

The **MODIFY COLORS** softkey within the adjust display menu provides access to the modify colors menu.

The modify colors menu allows you to adjust the colors on your analyzer's display. The default colors in this instrument were chosen to maximize your ability to discern the difference between the channel colors, and to comfortably and effectively view the colors. Each channel's memory trace color was chosen because the color is similar to the channels data trace color. This allows easy association between the data trace and the memory trace for each channel.

You may choose to change the default colors to suit environmental needs, individual preferences, or to accommodate color deficient vision. You can use any of the available colors for any of the display elements listed:

CH1 DATA/LIMIT LN

CH1 MEM

CH2 DATA/LIMIT LN

CH2 MEM

GRATICULE

TEXT

CH3 DATA/LIMIT LN

CH3 MEM

CH4 DATA/LIMIT LN

CH4 MEM

REF LINE

WARNING

To change the color of a display elements, press the softkey for that element (such as **CH1 DATA**). Then press **TINT** and turn the analyzer front panel knob; use the step keys or the numeric keypad, until the desired color appears.

NOTE Maximum viewing with the LCD display is achieved when primary colors or a combination of them are selected at full brightness (100%). [Table 1-2](#) lists the recommended colors and their

corresponding tint numbers.

Table 1-2 Display Colors with Maximum Viewing Angle

Display Color	Tint	Brightness	Color
Red	0	100	100
Yellow	17	100	100
Green	33	100	100
Cyan	50	100	100
Blue	67	100	100
Magenta	83	100	100
White	N/A	100	0

Color is comprised of three parameters:

- **Tint:** The continuum of hues on the color wheel, ranging from red, through green and blue, and back to red.
- **Brightness:** A measure of the brightness of the color.
- **Color:** The degree of whiteness of the color. A scale from white to pure color.

The most frequently occurring color deficiency is the inability to distinguish red, yellow, and green from one another. Confusion between these colors can usually be eliminated by increasing the brightness between the colors. To accomplish this, press the **BRIGHTNESS** softkey and turn the analyzer front panel knob. If additional adjustment is needed, vary the degree of whiteness of the color. To accomplish this, press the **COLOR** softkey and turn the analyzer front panel knob.

NOTE Color changes and adjustments remain in effect until changed again in these menus or the analyzer is powered off and then on again. Cycling the power changes all color adjustments to default values. Once the colors are saved, pressing the (Preset) key does not affect the color selections.

Saving Modified Colors

To save a modified color set, press **SAVE COLORS**. Modified colors are not part of a saved instrument state and are lost unless saved using these softkeys. Once modified colors are saved, they will be the colors applied until (Preset) is pushed.

Recalling Modified Colors

To recall the previously saved color set, press **RECALL COLORS**.

Using Markers

The **Marker** key displays a movable active marker on the screen and provides access to a series of menus to control up to five display markers for each channel. Markers are used to obtain numerical readings of measured values. They also provide capabilities for reducing measurement time by changing stimulus parameters, searching the trace for specific values, or statistically analyzing part or all of the trace.

Markers have a stimulus value (the x-axis value in a Cartesian format) and a response value (the y-axis value in a Cartesian format). In polar format, the second part of a complex data pair is also provided as an auxiliary response value. In Smith chart format, the real and imaginary rectangle are both displayed, and the effective capacitance or inductance of the imaginary part is also displayed. When a marker is activated and no other function is active, its stimulus value is displayed in the active entry area and can be controlled with the knob, the step keys, or the numeric keypad. The active marker can be moved to any point on the trace, and its response and stimulus values are displayed at the top right corner of the graticule for each displayed channel, in units appropriate to the display format. The displayed marker response values are valid even when the measured data is above or below the range displayed on the graticule.

- If you activate both data and memory traces, the marker values apply to the data trace.
- If you activate only the memory trace, the marker values apply to the memory trace.
- If you activate a memory math function (data/memory or data-memory), the marker values apply to the trace resulting from the memory math function.

Marker values are normally continuous: that is, they are interpolated between measured points. They can also be set to read only discrete measured points. Markers normally have the same stimulus values for all channels, or they can be uncoupled so that each channel has independent markers, regardless of whether stimulus values are coupled or dual channel display is on.

To Use Continuous and Discrete Markers

The analyzer can either place markers on discrete measured points, or move the markers continuously along a trace by interpolating the data value between measured points.

- Press **Marker Fctn** **MARKER MODE MENU** and select one of the following choices:
 - Choose **MARKERS: CONTINUOUS** if you want the analyzer to place markers at any point on the trace, by interpolating between measured points. This default mode allows you to conveniently obtain round numbers for the stimulus value.
 - Choose **MARKERS: DISCRETE** if you want the analyzer to place markers only on measured trace points determined by the stimulus settings. This may be the best mode to use with automated testing, using a computer or test sequencing because the analyzer does not interpolate between measured points.

NOTE Using **MARKERS: DISCRETE** will also affect marker search and positioning functions when the value entered in a search or positioning function does not exist as a measurement point. The marker will be positioned to the closest adjacent point that satisfies the search or positioning value.

To Activate Display Markers

- To switch on marker 1 and make it the active marker, press:

Marker **MARKER 1**

The active marker is identified on the analyzer display with the following symbol: ▽

The active marker stimulus value is displayed in the active entry area. You can modify the stimulus value of the active marker, using the front panel knob or numerical keypad. All of the marker response and stimulus values are displayed in the upper right corner of the display.

Figure 1-12 Active Marker Control Example

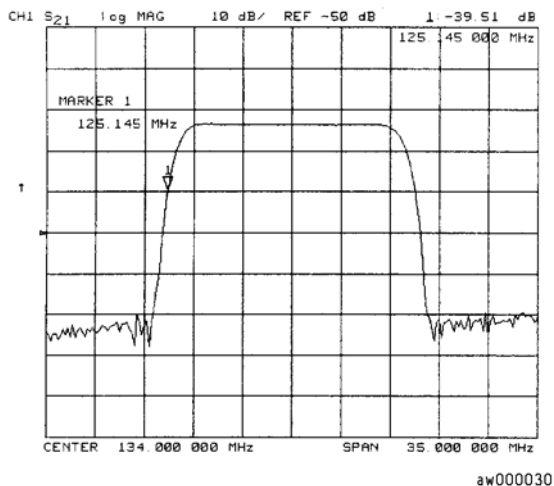

To switch on the corresponding marker and make it the active marker, press:

MARKER 2 **MARKER 3** , **MARKER 4** , or **MARKER 5**

All of the markers, other than the active marker, become inactive and are represented on the analyzer display as Δ . The active and inactive markers are shown in [Figure 1-13](#).

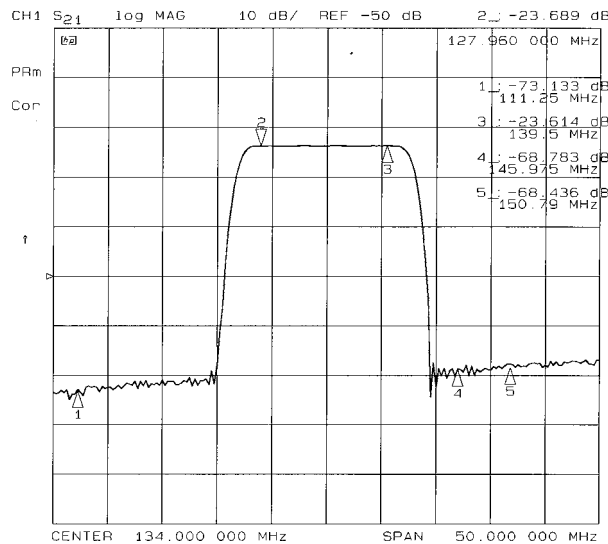

Figure 1-13 Active and Inactive Markers Example



pa5109e

- To switch off all of the markers, press **ALL OFF**.

To Move Marker Information Off the Grids

If marker information obscures the display traces, you can turn off the softkey menu and move the marker information off the display traces and into the softkey menu area. Pressing the backspace key  performs this function. This is a toggle function. Pressing  alternately hides and restores the current softkey menu. The softkey menu is also restored when you press any softkey or a hardkey which leads to a menu.

- Set up a four-graticule display as described in ["Viewing Four Measurement Channels" on page 1-14](#).
- Activate four markers by pressing **Marker** **1** **2** **3** **4**.

NOTE Observe that the markers appear on all of the grids. To activate markers on individual grids, press **Marker Fctn** **MARKER MODE MENU**, and set **MARKERS:** to **UNCOUPLED**. Then, activate the channel in which you wish to have markers, press **Marker**, then select the markers for that channel.

- Turn off the softkey menu and move the marker information off the grids by pressing .

The display will be similar to [Figure 1-14](#).

Figure 1-14 Marker Information Moved into the Softkey Menu Area

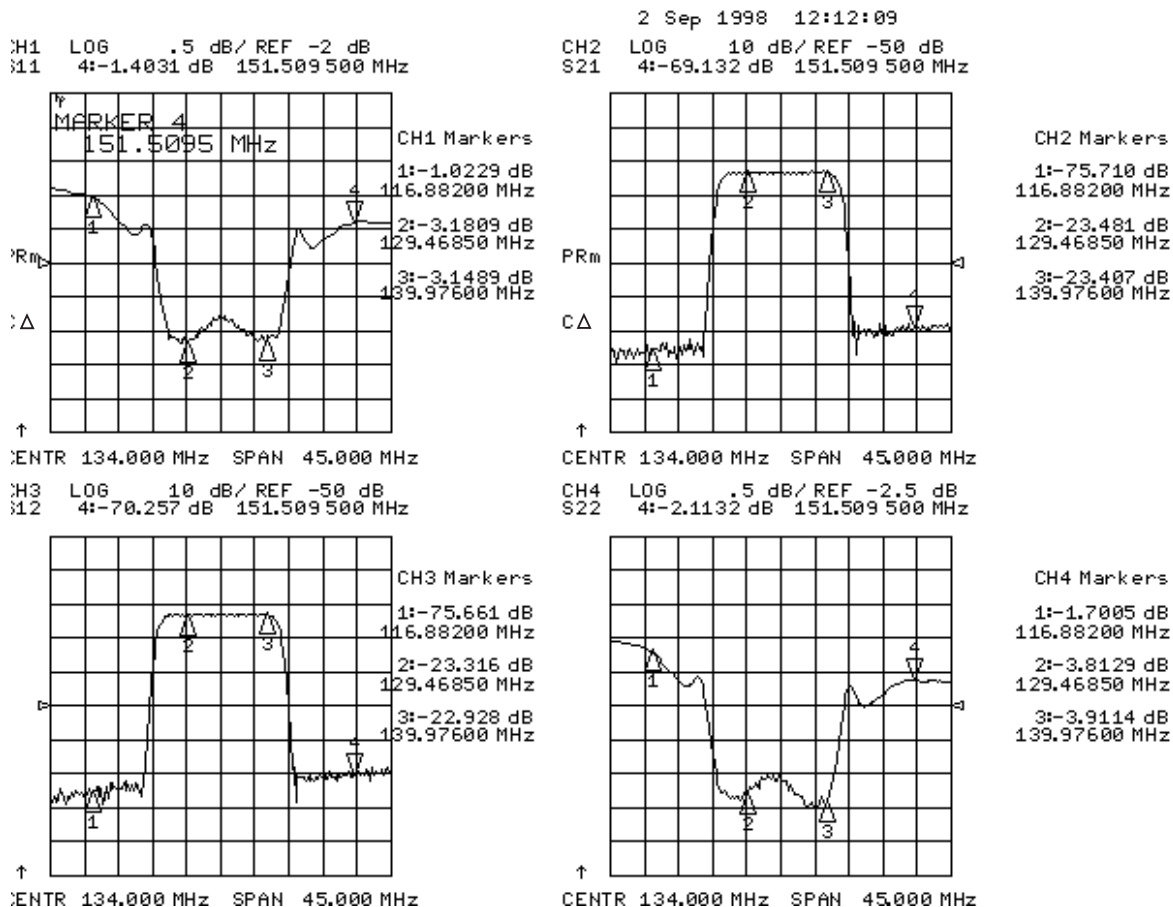

pg654e

4. Restore the softkey menu and move the marker information back onto the graticules: Press . The display will be similar to [Figure 1-15](#).

Figure 1-15 Marker Information on the Graticules

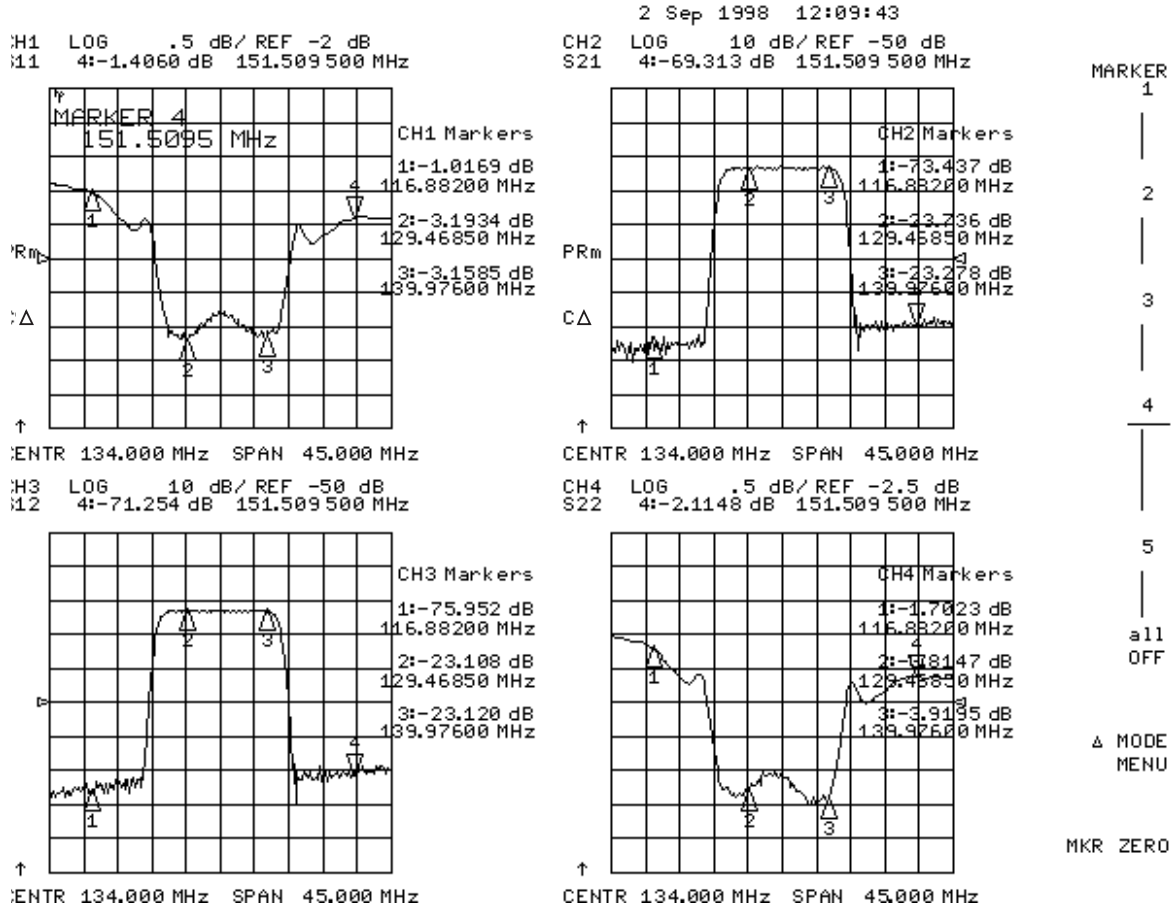

pg655e

You can also restore the softkey menu by pressing a hardkey which opens a menu (such as **Meas**) or pressing a softkey.

To Use Delta (Δ) Markers

This is a relative mode, where the marker values show the position of the active marker relative to the delta reference marker. You can switch on the delta mode by defining one of the five markers as the delta reference.

1. Press **Marker** **Δ MODE MENU** **Δ REF=1** to make marker 1 a reference marker.
2. To move marker 1 to any point that you want to reference:
 - Turn the front panel knob.
 - OR
 - Enter the frequency value (relative to the reference marker) on the numeric keypad.
3. Press **MARKER 2** and move marker 2 to any position that you want to measure in reference to marker 1.

Figure 1-16 Marker 1 as the Reference Marker Example

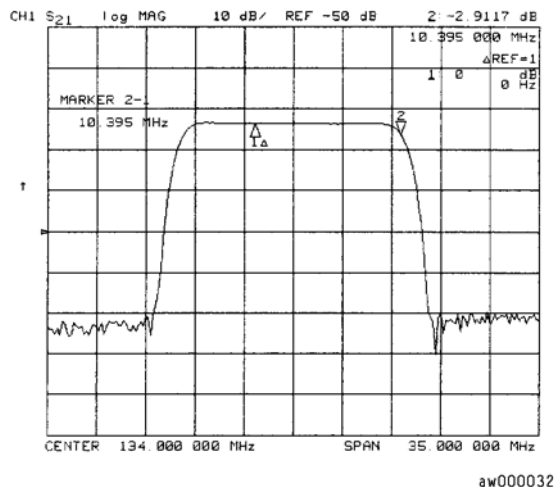

- To change the reference marker to marker 2, press:

Δ MODE MENU **Δ REF=2**

To Activate a Fixed Marker

When a reference marker is fixed, it does not rely on a current trace to maintain its fixed position. This is convenient when comparing two different measurement conditions. To activate a fixed marker on the analyzer, press **Marker** **MKR ZERO**.

Marker zero puts a fixed reference at the current position of the active marker.

To change to a Delta Marker to a fixed reference marker, press **Marker** **Δ MODE MENU** **ΔREF=ΔFIXED MKR**.

Using the **MKR ZERO** Key to Activate a Fixed Reference Marker

Marker zero enters the position of the active marker as the Δ reference position. Alternatively, you can specify the fixed point with **FIXED MKR POSITION**. Marker zero is canceled by switching delta mode off.

- To place marker 1 at a point that you would like to reference, press:

Marker and turn the front panel knob, or enter a value from the front panel keypad.

- To measure values along the measurement data trace, relative to the reference point that you set in the previous step, press:

MKR ZERO and turn the front panel knob, or enter a value from the front panel keypad.

- To move the reference position, press:

ΔMODE MENU **FIXED MKR POSITION** **FIXED MKR STIMULUS** and turn the front panel knob, or enter a value from the front panel keypad.

Figure 1-17 Example of a Fixed Reference Marker Using MKR ZERO

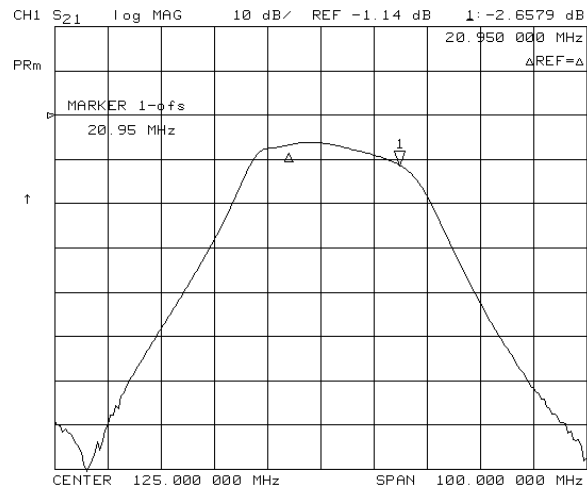

Using the Δ REF= Δ FIXED MKR Key to Activate a Fixed Reference Marker

1. To set the frequency value of a fixed marker that appears on the analyzer display, press:

Marker **Δ MODE MENU** **Δ REF= Δ FIXED MKR** **Δ MODE MENU**
FIXED MKR POSITION **FIXED MKR STIMULUS** and turn the front panel knob, or enter a value from the front panel keypad.

The marker is shown on the display as a small delta (Δ), smaller than Δ the inactive marker triangles.

2. To set the response value (dB) of a fixed marker, press:

FIXED MKR VALUE and turn the front panel knob, or enter a value from the front panel keypad.

In a Cartesian format, the setting is the y-axis value. In polar or Smith chart format, with a magnitude/phase marker, a real/imaginary marker, an R+jX marker, or a G+jB marker, the setting applies to the first part of the complex data pair. (Fixed marker response values are always uncoupled in the two channels.)

3. To set the auxiliary response value of a fixed marker when you are viewing a polar or Smith format, press:

FIXED MKR AUX VALUE and turn the front panel knob, or enter a value from the front panel keypad.

This value is the second part of complex data pair, and applies to a magnitude/phase marker, a real/imaginary marker, an R+jX marker, or a G+jB marker. (Fixed marker auxiliary response values are always uncoupled in the two channels.)

Figure 1-18 Example of a Fixed Reference Marker Using $(\Delta)REF=(\Delta)FIXED MKR$

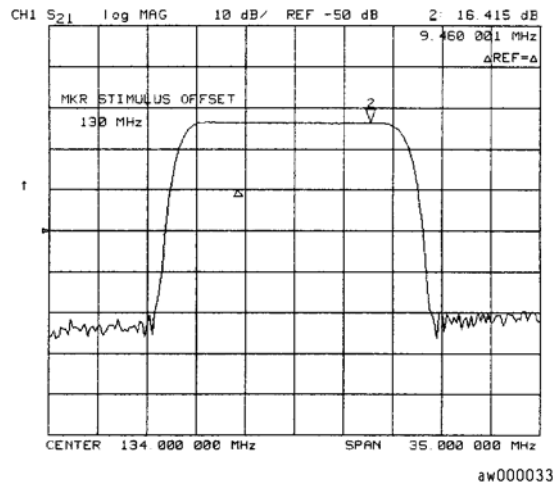

To Couple and Uncouple Display Markers

At a preset state, the markers have the same stimulus values on each channel, but they can be uncoupled so that each channel has independent markers.

Press **Marker Fctn** **MARKER MODE MENU** and select from the following keys:

- Choose **MARKERS: COUPLED** if you want the analyzer to couple the marker stimulus values for the display channels.
- Choose **MARKERS: UNCOUPLED** if you want the analyzer to uncouple the marker stimulus values for the display channels. This allows you to control the marker stimulus values independently for each channel.

Figure 1-19 Example of Coupled and Uncoupled Markers

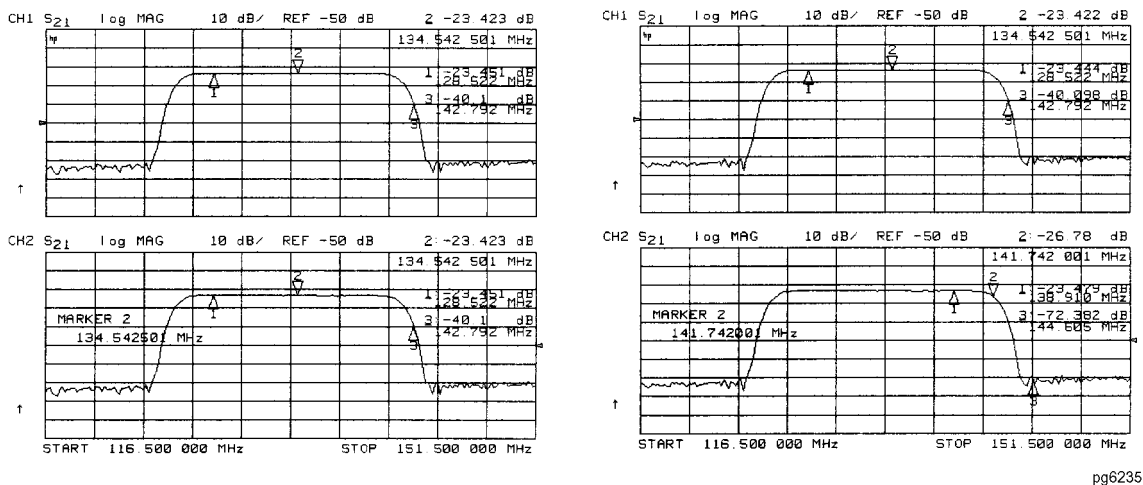

pg6235

To Use Polar Format Markers

The analyzer can display the marker value as magnitude and phase, or as a real/imaginary pair:

LIN MKR gives linear magnitude and phase, **LOG MKR** gives log magnitude and phase, **Re/Im** gives the real value first, then the imaginary value.

You can use these markers only when you are viewing a polar display format. (The format is available from the **Format** key.)

NOTE For greater accuracy when using markers in the polar format, it is recommended to activate the discrete marker mode. Press **Marker Fctn** **MKR MODE MENU** **MARKERS:DISCRETE**.

1. To access the polar markers, press:

Format **POLAR** **Marker Fctn** **MARKER MODE MENU** **POLAR MKR MENU**

2. Select the type of polar marker you want from the following choices:

- Choose **LIN MKR** if you want to view the magnitude and the phase of the active marker. The magnitude values appear in units and the phase values appear in degrees.
- Choose **LOG MKR** if you want to view the logarithmic magnitude and the phase of the active marker. The magnitude values appear in dB and the phase values appear in degrees.
- Choose **Re/Im MKR** if you want to view the real and imaginary pair, where the complex data is separated into its real part and imaginary part. The analyzer shows the real part as the first marker value ($M \cos \Theta$), and the second value is the imaginary part ($M \sin \Theta$, where M = magnitude).

Figure 1-20 Example of a Log Marker in Polar Format

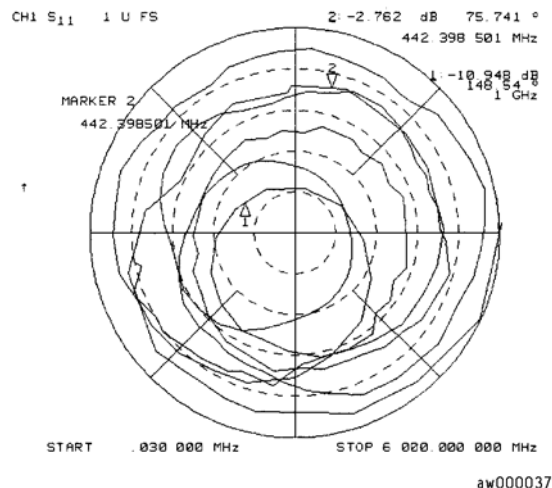

To Use Smith Chart Markers

For greater accuracy when using markers in the Smith chart format, activate the discrete marker mode.

Press **Marker Fctn** **MKR MODE MENU** **MARKERS:DISCRETE**.

To use Smith chart format:

1. Press **Format** **SMITH CHART**.
2. Press **Marker Fctn** **MARKER MODE MENU** **SMITH MKR MENU** and turn the front panel knob, or enter a value from the front panel keypad to read the resistive and reactive components of the complex impedance at any point along the trace. This is the default Smith chart marker.

The marker annotation tells that the complex impedance is capacitive in the bottom half of the Smith chart display and is inductive in the top half of the display.

- Choose **LIN MKR** if you want the analyzer to show the linear magnitude and the phase of the reflection coefficient at the marker.
- Choose **LOG MKR** if you want the analyzer to show the logarithmic magnitude and the phase of the reflection coefficient at the active marker. This is useful as a fast method of obtaining a reading of the log magnitude value without changing to log magnitude format.
- Choose **Re/Im MKR** if you want the analyzer to show the values of the reflection coefficient at the marker as a real and imaginary pair.
- Choose **R+jX MKR** to show the real and imaginary parts of the device impedance (the series resistance and reactance, in ohms) at the marker. Also shown is the equivalent series inductance or capacitance.
- Choose **G+jB MKR** to show the complex admittance values of the active marker in rectangular form. The active marker values are displayed in terms of conductance (in Siemens), susceptance, and equivalent parallel circuit capacitance or inductance. Siemens are the international unit of admittance and are equivalent to mhos (the inverse of ohms).

Figure 1-21 Example of Impedance Smith Chart Markers

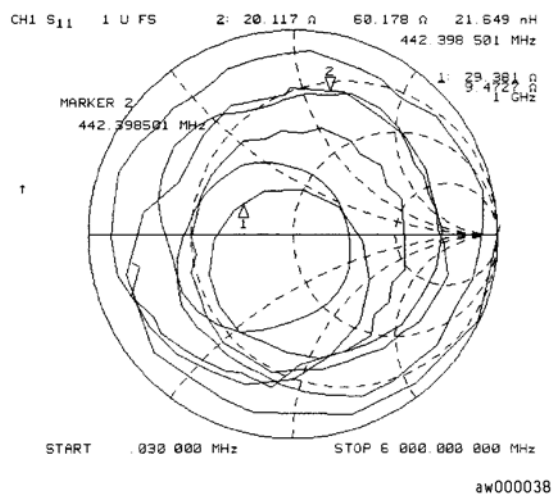

To Set Measurement Parameters Using Markers

The analyzer allows you to set measurement parameters with the markers, without going through the usual key sequence. You can change certain stimulus and response parameters to make them equal to the current active marker value.

Setting the Start Frequency

1. Press **Marker Fctn** and turn the front panel knob, or enter a value from the front panel keypad to position the marker at the value that you want for the start frequency.
2. Press **MARKER→START** to change the start frequency value to the value of the active marker.

Figure 1-22 Example of Setting the Start Frequency Using a Marker

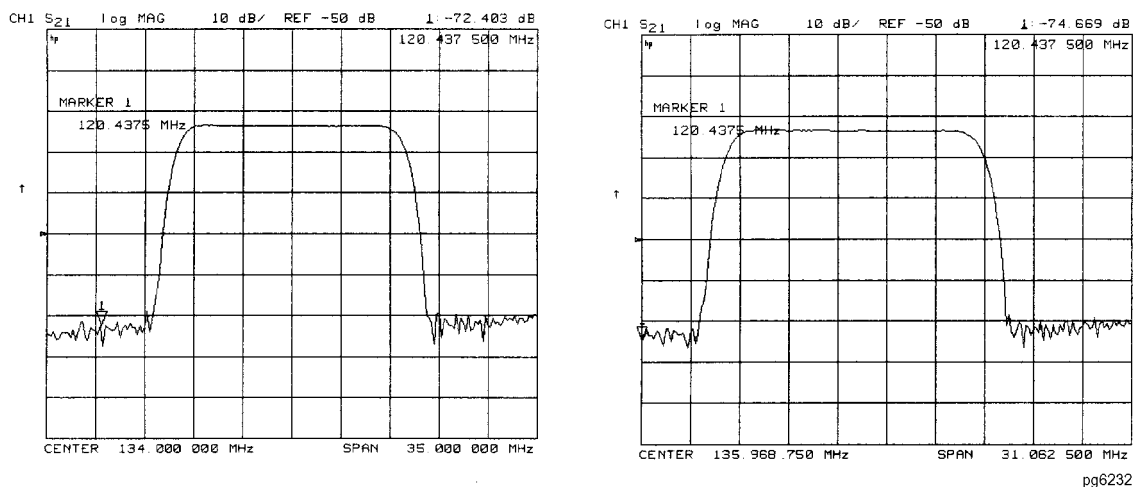

Setting the Stop Frequency

1. Press **Marker Fctn** and turn the front panel knob, or enter a value from the front panel keypad to position the marker at the value that you want for the stop frequency.
2. Press **MARKER→STOP** to change the stop frequency value to the value of the active marker.

Figure 1-23 Example of Setting the Stop Frequency Using a Marker

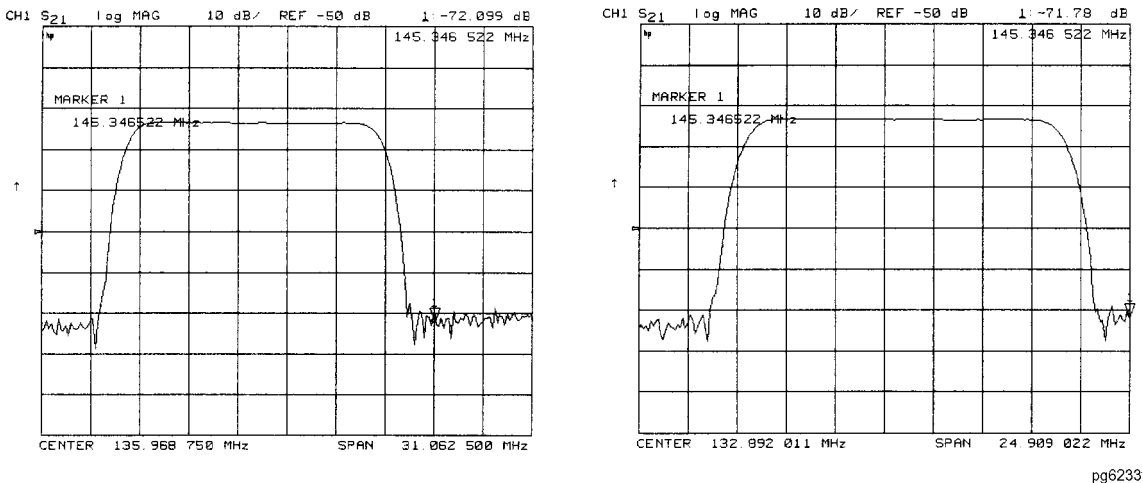

Setting the Center Frequency

1. Press **Marker Fctn** and turn the front panel knob, or enter a value from the front panel keypad to position the marker at the value that you want for the center frequency.
2. Press **MARKER→CENTER** to change the center frequency value to the value of the active marker.

Figure 1-24 Example of Setting the Center Frequency Using a Marker

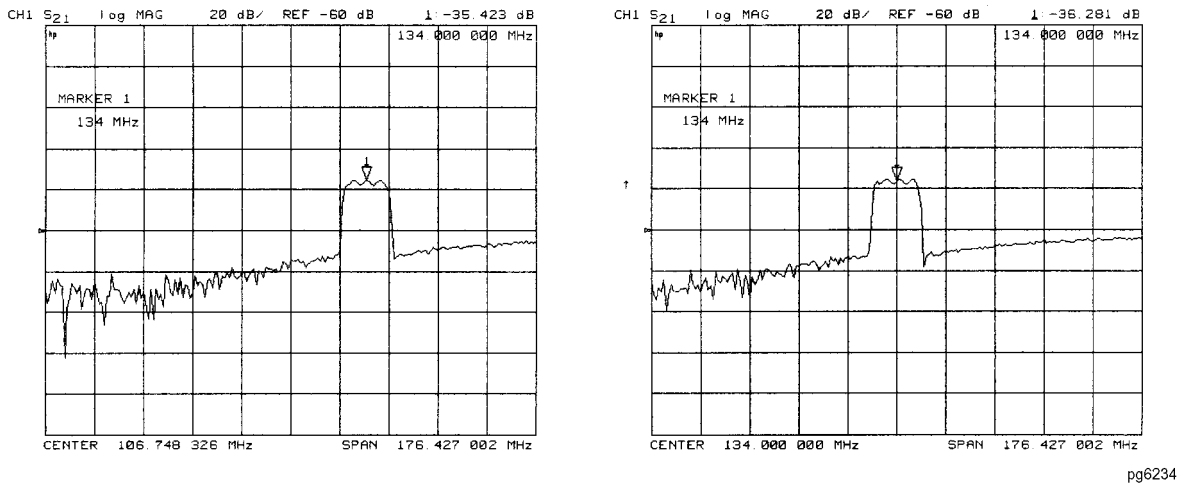

Setting the Frequency Span

You can set the span equal to the spacing between two markers. If you set the center frequency before you set the frequency span, you will have a better view of the area of interest.

1. Press **Marker** **ΔMODE MENU** **ΔREF=1** **MARKER 2**.
2. Turn the front panel knob, or enter a value from the front panel keypad to position the markers where you

Making Measurements Using Markers

want the frequency span.

Iterate between marker 1 and marker 2 by pressing **MARKER 1** and **MARKER 2**, respectively, and turning the front panel knob or entering values from the front panel keypad to position the markers around the center frequency. When finished positioning the markers, make sure that marker 2 is selected as the active marker.

NOTE Step 2 can also be performed using **MKR ZERO** and **MARKER 1**. However, when using this method, it will not be possible to iterate between marker zero and marker 1.

3. Press **Marker Fctn** **MARKER**→**SPAN** to change the frequency span to the range between marker 1 and marker 2.

Figure 1-25 Example of Setting the Frequency Span Using Marker

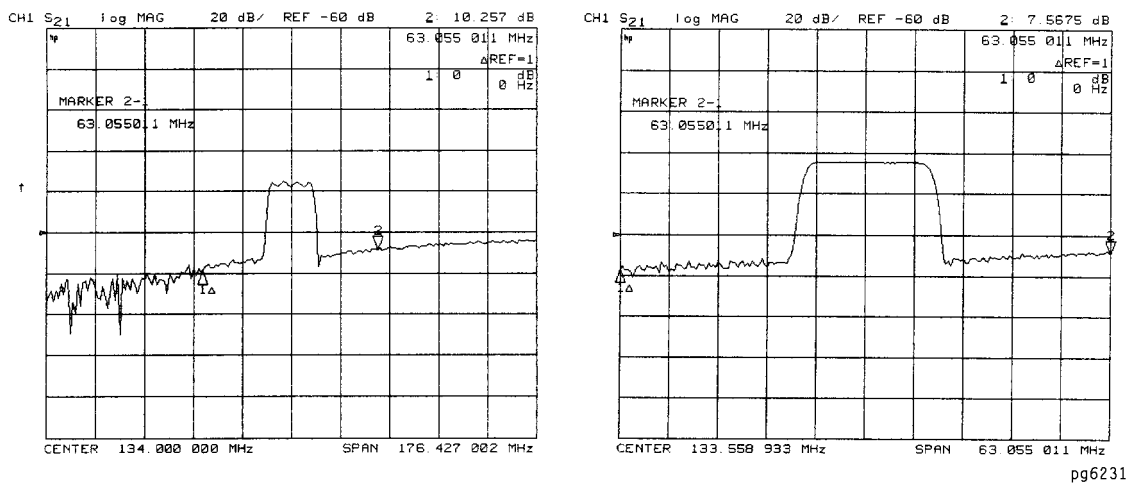

Setting the Display Reference Value

1. Press **Marker Fctn** and turn the front panel knob, or enter a value from the front panel keypad to position the marker at the value that you want for the analyzer display reference value.
2. Press **MARKER**→**REFERENCE** to change the reference value to the value of the active marker.

Figure 1-26 Example of Setting the Reference Value Using a Marker

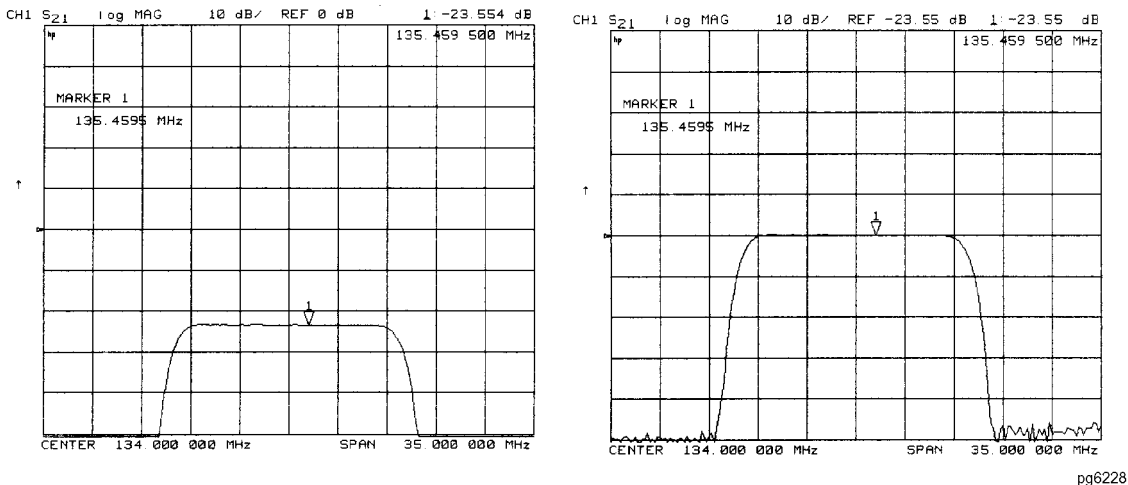

Setting the Electrical Delay

This feature adds phase delay to a variation in phase versus frequency, therefore it is only applicable for ratioed inputs.

1. Press **Format** **PHASE**.
2. Press **Marker Fctn** and turn the front panel knob, or enter a value from the front panel keypad to position the marker at a point of interest.
3. Press **MARKER**→**DELAY** to automatically add or subtract enough line length to the receiver input to compensate for the phase slope at the active marker position. This effectively flattens the phase trace around the active marker. You can use this to measure the electrical length or deviation from linear phase.

Additional electrical delay adjustments are required on devices without constant group delay over the measured frequency span.

Figure 1-27 Example of Setting the Electrical Delay Using a Marker

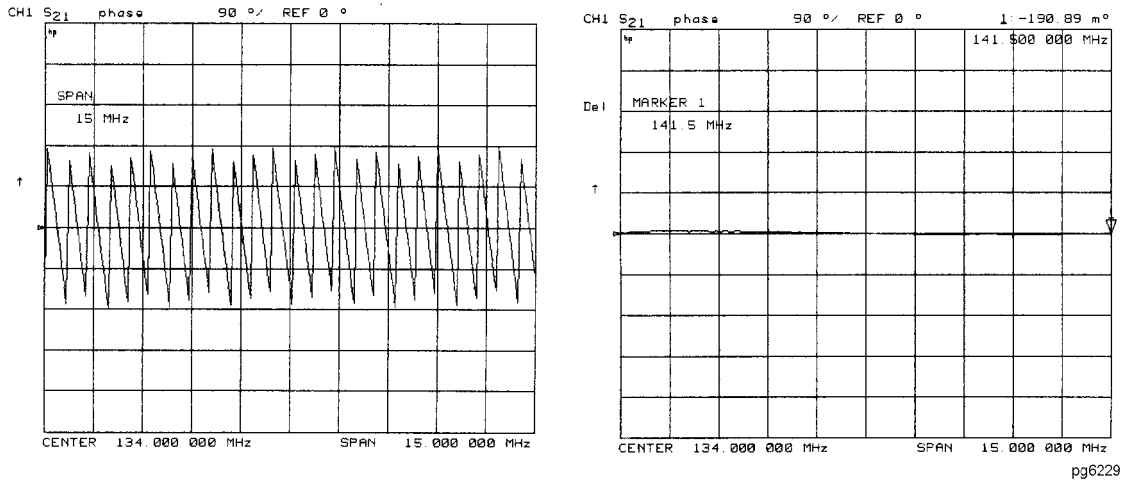

Setting the CW Frequency

1. To place a marker at the desired CW frequency, press:

Marker and either turn the front panel knob or enter the value, followed by a unit terminator.

2. Press **Seq** **SPECIAL FUNCTIONS** **MKR→CW**.

You can use this function to set the marker to a gain peak in an amplifier. After pressing **MKR→CW FREQ**, activate a CW frequency power sweep to look at the gain compression with increasing input power.

To Search for a Specific Amplitude

These functions place the marker at an amplitude-related point on the trace. If you switch on tracking, the analyzer searches every new trace for the target point.

Searching for the Maximum Amplitude

1. Press **Marker Search** to access the marker search menu.
2. Press **SEARCH: MAX** to move the active marker to the maximum point on the measurement trace.

Figure 1-28 Example of Searching for the Maximum Amplitude Using a Marker

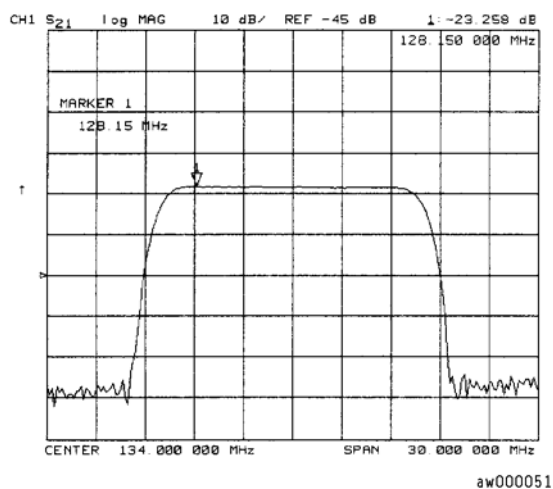

Searching for the Minimum Amplitude

1. Press **Marker Search** to access the marker search menu.
2. Press **SEARCH: MIN** to move the active marker to the minimum point on the measurement trace.

Figure 1-29 Example of Searching for the Minimum Amplitude Using a Marker

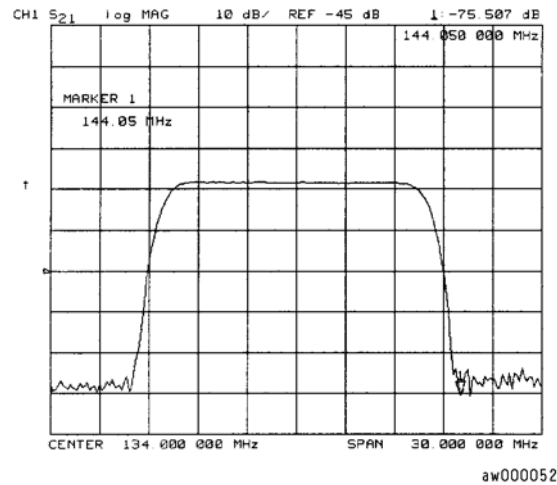

Searching for a Target Amplitude

1. Press **Marker Search** to access the marker search menu.
2. Press **SEARCH: TARGET** to move the active marker to the target point on the measurement trace.
3. If you want to change the target amplitude value (default is -3 dB), press **TARGET** and enter the new value from the front panel keypad. You may also press **Marker Search** **TARGET VALUE** to enter the new value.
4. If you want to search for multiple responses at the target amplitude value, press **SEARCH LEFT** and **SEARCH RIGHT**.

Figure 1-30 Example of Searching for a Target Amplitude Using a Marker

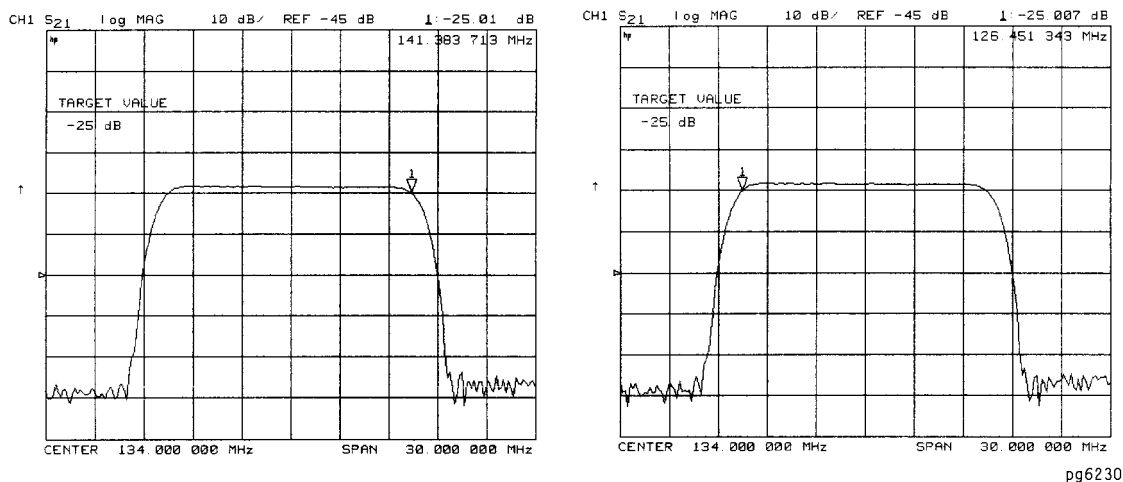

Searching for a Bandwidth

The analyzer can automatically calculate and display the bandwidth (BW:), center frequency (CENT:), Q, and loss of the device under test at the center frequency. (Q stands for “quality factor,” defined as the ratio of a circuit's resonant frequency to its bandwidth.) These values are shown in the marker data readout.

1. Press **Marker Search** and **SEARCH: MAX** to place the marker near the center of the filter passband.
2. Press **MKR ZERO** if you want the bandwidth relative to the maximum.
3. Press **Marker Search** to access the marker search menu.
4. Press **WIDTHS ON** to calculate the center stimulus value, bandwidth, and the Q of a bandpass or band reject shape on the measurement trace.
5. If you want to change the amplitude value (default is -3 dB) that defines the passband or reject band, press **WIDTH VALUE** and enter the new value from the front panel keypad.

Figure 1-31 Example of Searching for a Bandwidth Using Markers

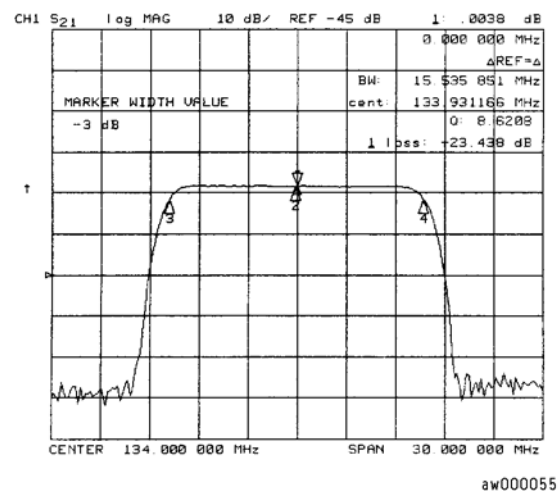

Tracking the Amplitude that You Are Searching

1. Set up an amplitude search by following one of the previous procedures in ["To Search for a Specific Amplitude"](#) on page 1-39.
2. Press **Marker Search** **TRACKING ON** to track the specified amplitude search with every new trace and put the active marker on that point.

When tracking is not activated, the analyzer finds the specified amplitude on the current sweep and the marker remains at same stimulus value, regardless of changes in the trace response value with subsequent sweeps.

To Calculate the Statistics of the Measurement Data

This function calculates the mean, standard deviation, and peak-to-peak values of the section of the displayed trace between the active marker and the delta reference. If there is no delta reference, the

Making Measurements Using Markers

analyzer calculates the statistics for the entire trace.

1. Move marker 1 to any point that you want to reference:
 - Turn the front panel knob.OR
 - Enter the frequency value on the numeric keypad.
2. Press **Marker** **Δ MODE MENU** **Δ REF=1** to make marker 1 a reference marker.
3. Press **MARKER 2** and move marker 2 to any position that you want to measure in reference to marker 1.
4. Press **Marker Fctn** **MKR MODE MENU** **MKR STATS ON** to calculate and view the mean, standard deviation, and peak-to-peak values of the section of the measurement data between the active marker and the delta reference marker.

An application for this feature is to find the peak-to-peak value of passband ripple without searching separately for the maximum and minimum values.

If you are viewing a measurement in the polar or Smith Chart format, the analyzer calculates the statistics using the first value of the complex pair (magnitude, real part, resistance, or conductance).

Figure 1-32 Example Statistics of Measurement Data

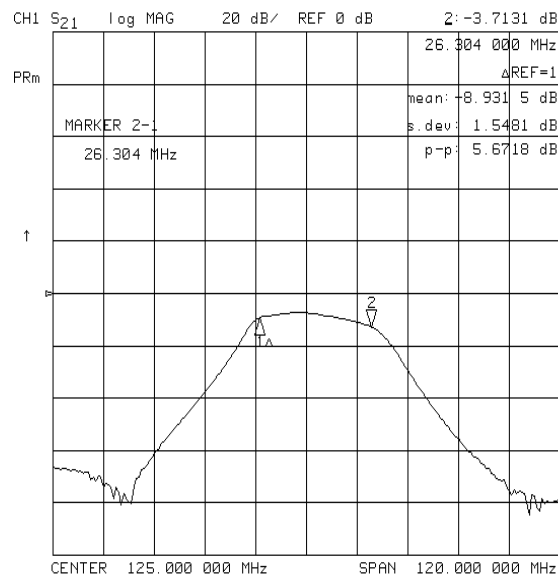

Measuring Electrical Length and Phase Distortion

Electrical Length

The analyzer mathematically implements a function similar to the mechanical “line stretchers” of earlier analyzers. This feature simulates a variable length lossless transmission line, which you can add to or remove from the analyzer's receiver input to compensate for interconnecting cables, etc. In this example, the electronic line stretcher measures the electrical length of a SAW filter.

Phase Distortion

The analyzer allows you to measure the linearity of the phase shift through a device over a range of frequencies and the analyzer can express it in two different ways:

- deviation from linear phase
- group delay

Measuring Electrical Length

1. Connect your test device as shown in [Figure 1-33](#).

Figure 1-33 Device Connections for Measuring Electrical Length

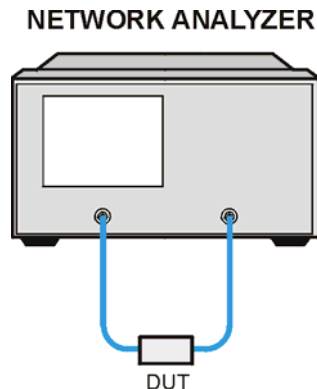

pa52e

2. Press **Preset** and choose the measurement settings. For this example, the measurement settings include reducing the frequency span to eliminate under-sampled phase response. Press the following keys as shown:

Meas **Trans:FWD S21 (B/R)** or on ET models: **TRANSMISSN**
Center **134** **M/μ**
Span **2** **M/μ**
Format **PHASE**
Scale Ref **AUTO SCALE**

You may also want to select settings for the number of data points, averaging, and IF bandwidth.

Measuring Electrical Length and Phase Distortion

- Substitute a thru for the device and perform a response calibration by pressing:

Cal CALIBRATE MENU RESPONSE THRU

- Reconnect your test device.
- To better view the measurement trace, press:

Scale Ref AUTO SCALE

Notice that in Figure 1-34 the SAW filter under test has considerable phase shift within only a 2 MHz span. Other filters may require a wider frequency span to see the effects of phase shift.

The linearly changing phase is due to the device's electrical length. You can measure this changing phase by adding electrical length (electrical delay) to compensate for it.

Figure 1-34 Linearly Changing Phase



pa5103e

- To place a marker at the center of the band, press **Marker** and turn the front panel knob, or enter a value from the front panel keypad.
- To activate the electrical delay function, press **Marker Fctn** **MARKER**→**DELAY**.

This function calculates and adds in the appropriate electrical delay by taking a $\pm 10\%$ span about the marker, measuring the $\Delta\Phi$, and computing the delay as the negative of $\Delta\Phi / \Delta$ frequency.

Alternatively, press **Scale Ref** **ELECTRICAL DELAY** and turn the front panel knob to increase the electrical length until you achieve the best flat line, as shown in Figure 1-35.

The measurement value that the analyzer displays represents the electrical length of your device relative to the speed of light in free space. The physical length of your device is related to this value by the propagation velocity of its medium.

NOTE Velocity factor is the ratio of the velocity of wave propagation in a coaxial cable to the velocity of wave propagation in free space. Most cables have a relative velocity of about 0.66 the speed in free space. This velocity depends on the relative permittivity of the cable dielectric (ϵ_r) as

$$\text{Velocity Factor} = \frac{1}{\sqrt{\epsilon_r}}$$

You could change the velocity factor to compensate for propagation velocity by pressing **Cal** **MORE** **VELOCITY FACTOR** (enter the value) **x1**. This will allow the analyzer to accurately display the equivalent distance that corresponds to the entered electrical delay.

Figure 1-35 Example Best Flat Line with Added Electrical Delay

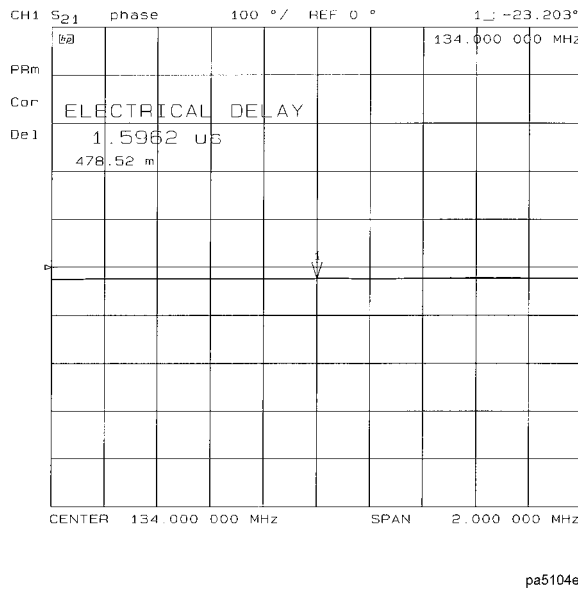

- To display the electrical length, press **Scale Ref** **ELECTRICAL DELAY**.

In this example, there is a large amount of electrical delay due to the long electrical length of the SAW filter under test.

Measuring Phase Distortion

This portion of the example shows you how to measure the linearity of the phase shift over a range of frequencies. The analyzer allows you to measure this linearity and read it in two different ways: deviation from linear phase, or group delay.

Deviation From Linear Phase

By adding electrical length to “flatten out” the phase response, you have removed the linear phase shift through your device. The deviation from linear phase shift through your device is all that remains.

1. Follow the procedure in "[Measuring Electrical Length](#)" on page 1-43.
2. To increase the scale resolution, press **Scale Ref** **SCALE DIV** and turn the front panel knob, or enter a value from the front panel keypad.
3. To use the marker statistics to measure the maximum peak-to-peak deviation from linear phase, press **Marker Fctn** **MKR MODE MENU** **STATS ON**.
4. Activate and adjust the electrical delay to obtain a minimum peak-to-peak value.

NOTE It is possible to use delta markers to measure peak-to-peak deviation in only one portion of the trace. See "[To Calculate the Statistics of the Measurement Data](#)" on page 1-41.

Figure 1-36 Deviation From Linear Phase Example Measurement

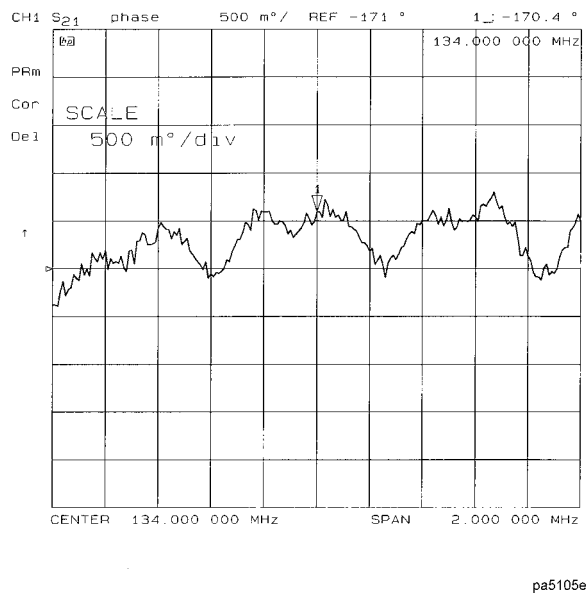

Group Delay



The phase linearity of many devices is specified in terms of group or envelope delay. The analyzer can translate this information into a related parameter, group delay. Group delay is the transmission time through your device under test as a function of frequency. Mathematically, it is the derivative of the phase response which can be approximated by the following ratio:

$$-\Delta\Phi / (360 \times \Delta\Phi)$$

where $\Delta\Phi$ is the difference in phase at two frequencies separated by ΔF . The quantity ΔF is commonly called the “aperture” of the measurement. The analyzer calculates group delay from its phase response measurements.

The default aperture is the total frequency span divided by the number of points across the display (i.e. 201 points or 0.5% of the total span in this example).

1. Continue with the same instrument settings and measurements as in the previous procedure, “Deviation From Linear Phase.”
2. To view the measurement in delay format, as shown in Figure 1-37, press:

Format **DELAY** **Scale Ref** **SCALE DIV**  

3. To activate a marker to measure the group delay at a particular frequency, press **Marker** and turn the front panel knob, or enter a value from the front panel keypad.

Figure 1-37 Group Delay Example Measurement

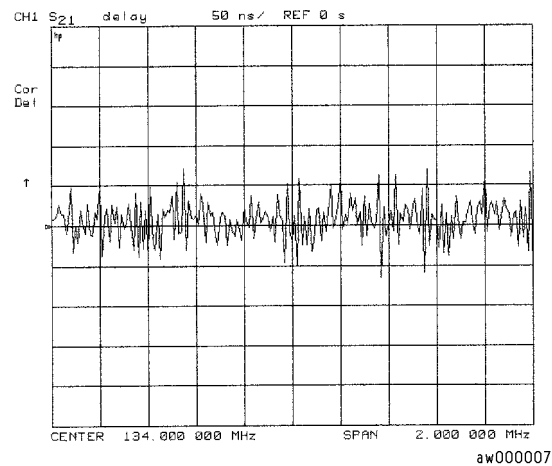

Group delay measurements may require a specific aperture (ΔF) or frequency spacing between measurement points. The phase shift between two adjacent frequency points must be less than 180° , otherwise incorrect group delay information may result.

4. To vary the effective group delay aperture from minimum aperture (no smoothing) to approximately 1% of the frequency span, press: **Avg** **SMOOTHING ON**.

When you increase the aperture, the analyzer removes fine grain variations from the response. It is critical that you specify the group delay aperture when you compare group delay measurements.

Figure 1-38 Group Delay Example Measurement with Smoothing

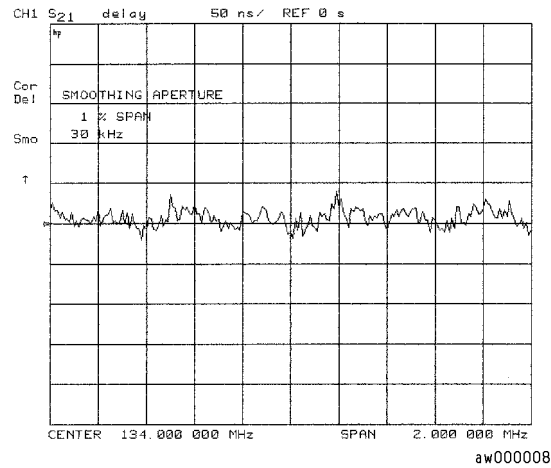

- To increase the effective group delay aperture, by increasing the number of measurement points over which the analyzer calculates the group delay, press:

SMOOTHING APERTURE **5** **x1**

As the aperture is increased the “smoothness” of the trace improves markedly, but at the expense of measurement detail.

Figure 1-39 Group Delay Example Measurement with Smoothing Aperture Increased

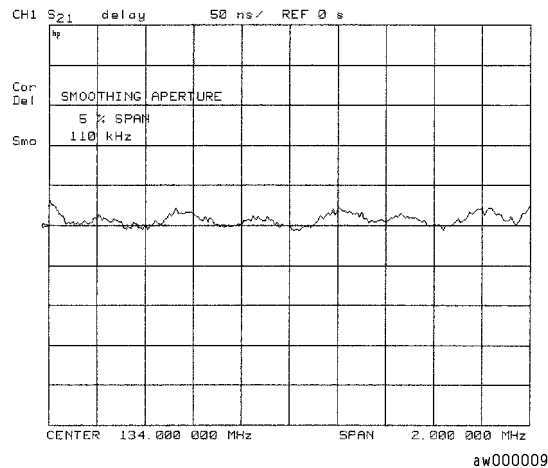

Group delay is calculated by dividing the phase difference between points by the frequency spacing. Thus, if n equals the number of points, the number of phase difference values (or frequency segments) will be $n-1$. The first data point is repeated so that the total number of points remains n .

Characterizing a Duplexer (ES Analyzers Only)

This measurement example demonstrates how to characterize a 3-port device, in this case a duplexer, using four-parameter display mode. You must use a test adapter or a special 3-port test adapter to route the signals from the analyzer (a two-port instrument) to the duplexer (a three-port device). This example procedure is performed using one of the following test adapters:

- ❑ 8720D Option K36 Duplexer Switching Test Set
- ❑ 8720D Option K39 3-Port Switching Test Set

Definitions

The following abbreviations are used in reference to a duplexer:

Tx	Transmitter port
Ant	Antenna port
Rx	Receiver port

Procedure

1. Press **Preset**.
2. Connect the test adapter to the analyzer according to the instructions for your particular model. Connect any test fixture or cables to the duplexer test adapter. Refer to [Figure 1-40](#).

Figure 1-40 Duplexer Connections

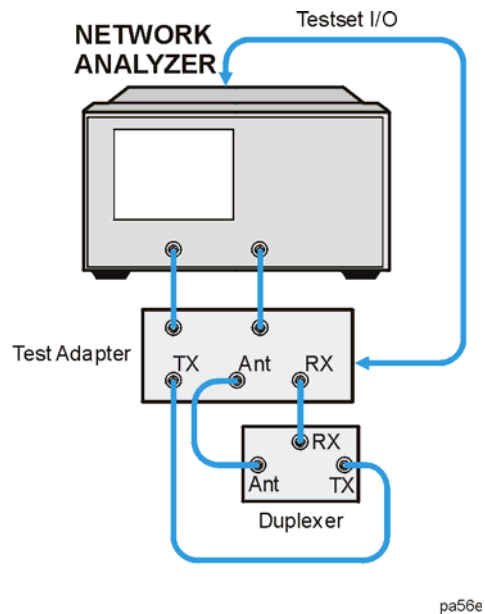

3. Set up channel 1 for the Tx-Ant stimulus parameters (start/stop frequency, power level, IF bandwidth). In this example, a wide frequency range that covers both the Tx-Ant and Ant-Rx parameters has been

Characterizing a Duplexer (ES Analyzers Only)

chosen.

4. Uncouple the primary channels from each other and then press **Sweep Setup** and toggle **COUPLED CH on OFF** to **OFF**.
5. Press **System** **CONFIGURE MENU** **USER SETTINGS**.
6. Set up the desired mode.
 - For K36 mode, toggle **K36 MODE on OFF** to ON. Then, press **Meas** **SELECT [TX-ANT]**.
 - For K39 mode, toggle **K39 MODE on OFF** to ON. Then, press **Meas** **SELECT PORTS [1-3]**.
7. Perform a full two-port calibration on channel 1 (refer to [Chapter 6](#), “Calibrating for Increased Measurement Accuracy,” if necessary).

NOTE Make sure you connect the standards to the Tx port of the test adapter (or a cable attached to it) for FORWARD calibrations, and to the Ant port for REVERSE calibrations.

8. Save the instrument state by pressing **Save/Recall** **SAVE STATE**.
9. Press **Chan 2**.
10. Set up channel 2 for the Ant-Rx stimulus parameters. In this example, a wide frequency range that covers both the Tx-Ant and Ant-Rx parameters has been chosen.
11. Set up control of the test adapter so that channels 2 and 4 are Rx:
 - For K36 mode, press **Meas** **SELECT [RX-ANT]**.
 - For K39 mode, press **Meas** **SELECT PORTS [2-3]**.
12. Perform a full two-port calibration on channel 2.

NOTE Make sure you connect the standards to the Rx port of the test adapter (or a cable attached to it) for FORWARD calibrations, and to the Ant port for REVERSE calibrations.

13. Save this state in the analyzer:
Press **Save/Recall** **SAVE STATE**.
14. Connect the duplexer to the test adapter.

15. Set up a 2-graticule, 4-parameter display with transmission measurements on the top graticule and reflection measurements on the bottom graticule:

Press **Display** **DUAL|QUAD SETUP** **4-PARAM DISPLAYS** **SETUP B** **Meas**
Trans: REV S12 (A/R)

Chan 4 **Ref1: REV S22 (B/R)** **Chan 1** **Trans:FWD S21 (B/R)** **Chan 3**
Ref1: FWD S11 (A/R), then set **DUAL CHAN on OFF** to **ON**.

The display will be similar to [Figure 1-41](#).

Figure 1-41 Duplexer Measurement

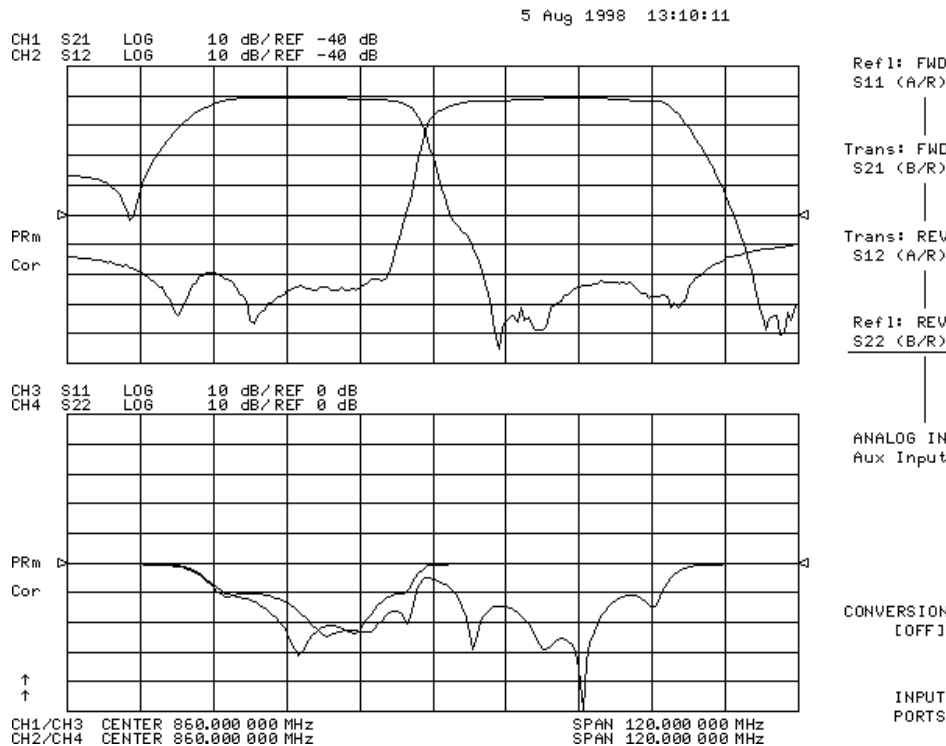

Normally, a 2-port calibration requires a forward and reverse sweep to complete before the displayed trace updates. For faster tuning, it is possible to set the number of sweeps for the active display channel (S_{11} and S_{21} for channel 1 in this case) to update more often than the inactive display channel. In this example we choose 8 updates of the forward parameters to 1 update of the reverse in channel 1, and 8 updates of the reverse to 1 update of the forward in channel 2 (where the active parameters are S_{22} and S_{12}).

Press **Chan 1** **System** **CONFIGURE MENU** **TESTSET SW CONTINUOUS** **8** **x1**.
 Press **Chan 2** **System** **CONFIGURE MENU** **TESTSET SW CONTINUOUS** **8** **x1**.

Measuring Amplifiers

The analyzer allows you to measure the transmission and reflection characteristics of many amplifiers and active devices. You can measure scalar parameters such as gain, gain flatness, gain compression, reverse isolation, return loss (SWR), and gain drift versus time. Additionally, you can measure vector parameters such as deviation from linear phase, group delay, complex impedance and AM-to-PM conversion. You can also make high power measurements.

Figure 1-42 Amplifier Parameters

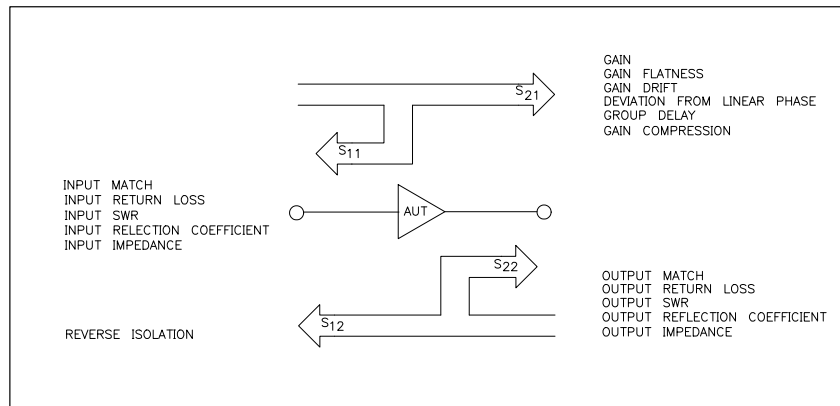

pg6137d

When you are measuring a device that is very sensitive to absolute power level, it is important that you accurately set the power level at either the device input or output. The analyzer is capable of using an external GPIB power meter and controlling source power directly. Refer to [Chapter 6, "Calibrating for Increased Measurement Accuracy"](#) for information on power meter calibration.

This section contains the following measurement examples:

- ["Measuring Gain Compression" on page 1-53](#)
- Measuring Gain and Reverse Isolation Simultaneously
- Making High Power Measurements
 - Option 085 Configuration
 - Option 012 Configuration

Measuring Gain Compression

Gain compression occurs when the input power of an amplifier is increased to a level that reduces the gain of the amplifier and causes a nonlinear increase in output power. The point at which the gain is reduced by 1 dB is called the 1 dB compression point. The gain compression will vary with frequency, so it is necessary to find the worst-case point of gain compression in the frequency band.

Once that point is identified, you can perform a power sweep of that CW frequency to measure the input power at which the 1 dB compression occurs and the absolute power out (in dBm) at compression. The following steps provide detailed instruction on how to apply various features of the analyzer to accomplish these measurements.

NOTE In a compression measurement it is necessary to know the RF input or output power at a certain level of gain compression. Therefore, both gain and absolute power level need to be accurately characterized. Uncertainty in a gain compression measurement is typically less than 0.05 dB. Also, each input channel of the analyzer is calibrated to display absolute power (typically within +0.5 dBm up to 3 GHz, and +1 dB up to 6 GHz). This can be improved by calibrating the power meter. Refer to "[Power Meter Measurement Calibration](#)" on page 6-33 for information on calibrating the power meter.

Figure 1-43 Diagram of Gain Compression

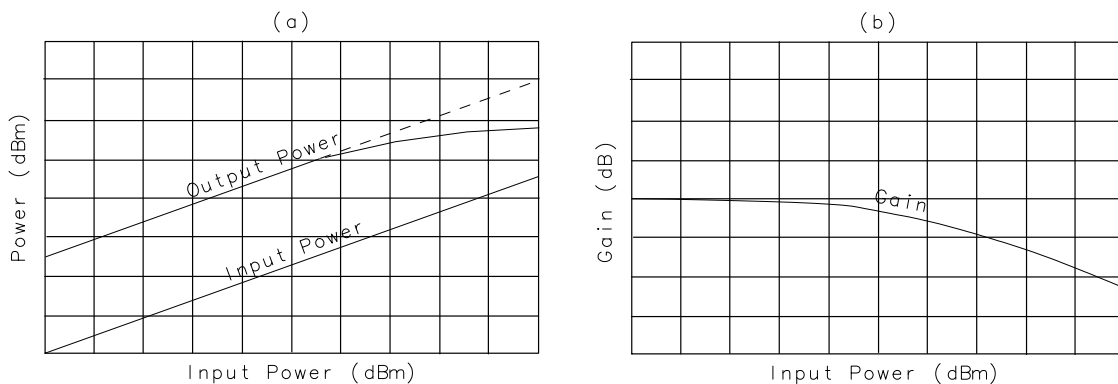

pb697d

1. Set up the stimulus and response parameters for your amplifier under test. To reduce the effect of noise on the trace, press:

Avg **IF BW** **1000** **x1**

Chan 1 **Meas** **Trans:FWD S21 (B/R)** or on ET models: **TRANSMISSN**

2. Perform the desired error correction procedure. Refer to [Chapter 6](#), "[Calibrating for Increased Measurement Accuracy](#)" for instructions on how to make a measurement correction.
3. Connect the amplifier under test.
4. To produce a normalized trace that represents gain compression, perform either step 5 or step 6. (Step 5 uses trace math and step 6 uses uncoupled channels and the display function **D1/D2 to D2 ON**.)
5. Press **Display** **DATA →MEMORY** **DATA/MEM** to produce a normalized trace.

Making Measurements Measuring Amplifiers

6. To produce a normalized trace, perform the following steps:

- Press **Display** **DUAL | QUAD SETUP** and select **DUAL CHANNEL ON** to view both channels simultaneously.
- Press **Chan 2** **Meas** **Trans:FWD S21 (B/R)** or on ET models: **TRANSMISSN**
- To uncouple the channel stimulus so that the channel power will be uncoupled, press:

Sweep Setup **COUPLED CH OFF**

This will allow you to separately increase the power for channel 2 and channel 1, so that you can observe the gain compression on channel 2 while channel 1 remains unchanged.

- To display the ratio of channel 2 data to channel 1 data on the channel 2 display, press:

Chan 2 **DISPLAY** **MORE** **D2/D1 to D2 ON**

This produces a trace that represents gain compression only.

7. Press **Marker** **MARKER 1** and position the marker at approximately mid-span.
8. Press **Scale Ref** **SCALE/DIV** **(x1)** to change the scale to 1 dB per division.
9. Press **Power**.
10. Increase the power until you observe approximately 1 dB of compression on channel 2, using the step keys or the front panel knob.
11. To locate the worst case point on the trace, press:

Marker Search **SEARCH:MIN**

Figure 1-44 Gain Compression Using Linear Sweep and D2/D1 to D2 ON

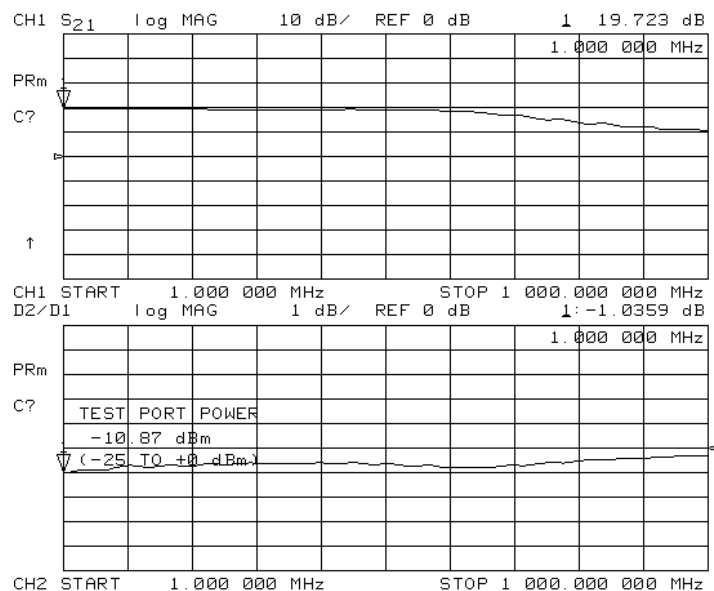

12. If **COUPLED CH OFF** was selected, recouple the channel stimulus by pressing:

Sweep Setup **COUPLED CH ON**

13. To place the marker *exactly* on a measurement point, press:

Marker Fctn **MARKER MODE MENU** **MARKERS:DISCRETE**

14. To set the CW frequency before going into the power sweep mode, press:

Seq **SPECIAL FUNCTIONS** **MARKER→ CW**

15. Press **Sweep Setup** **SWEEP TYPE MENU** **POWER SWEEP**.

If interpolation is on (the default setting), the calibration will be applied to the power sweep.

16. Enter the start and stop power levels for the sweep.

Now channel 1 is displaying a gain compression curve. (Do not pay attention to channel 2 at this time.)

17. Press **Chan 2** **Display** **DUAL | QUAD SETUP** **DUAL CHANNEL ON**.

18. If **D2/D1 to D2 ON** was selected, press **MORE** **D2/D1 to D2 OFF**.

19. Press **Meas** **INPUT PORTS** **B**.

Now channel 2 displays absolute output power (in dBm) as a function of power input.

20. Press **Scale Ref** **SCALE/DIV** **10** **x1** to change the scale of channel 2 to 10 dB per division.

21. Press **Chan 1** **1** **x1** to change the scale of channel 1 to 1 dB per division.

NOTE A receiver calibration will improve the accuracy of this measurement. Refer to [Chapter 6](#), “Calibrating for Increased Measurement Accuracy.”

22. Press **Marker Fctn** **MARKER MODE MENU** **MARKERS:COUPLED**.

23. To find the 1 dB compression point on channel 1, press:

Marker Search **SEARCH:MAX** **Marker** **MKR ZERO** **Marker Search**
SEARCH:TARGET **-1** **x1**

Notice that the marker on channel 2 tracked the marker on channel 1.

24. Press **Chan 2** **Marker** **MKR MODE MENU** **MARKERS:UNCOUPLED**.

25. To take the channel 2 marker out of the Δ mode so that it reads the absolute output power of the amplifier (in dBm), press:

Marker **Δ MODE MENU** **Δ MODE OFF**

Figure 1-45 Gain Compression Using Power Sweep

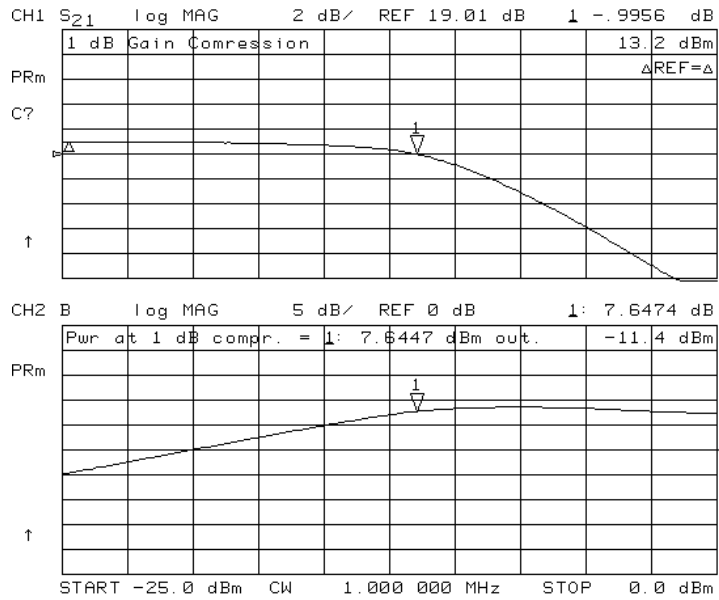

Measuring Gain and Reverse Isolation Simultaneously (ES Analyzers Only)

Since an amplifier will have high gain in the forward direction and high isolation in the reverse direction, the gain (S_{21}) will be much greater than the reverse isolation (S_{12}). Therefore, the power you apply to the input of the amplifier for the forward measurement (S_{21}) should be considerably lower than the power you apply to the output for the reverse measurement (S_{12}). By applying low power in the forward direction, you'll prevent the amplifier from being saturated. A higher power in the reverse direction keeps noise from being a factor in the measurement and accounts for any losses caused by attenuators or couplers on the amplifier's output needed to lower the output power into the analyzer. The following steps demonstrate the features that best accomplish these measurements.

1. Press **Sweep Setup** **COUPLED CH ON**.

Coupling the channels allows you to have the same frequency range and calibration applied to channel 1 and channel 2.

2. Press **Power** **PORT POWER [UNCOUPLED]**.

Uncoupling the port power allows you to apply different power levels at each port. In [Figure 1-46](#), the port 1 power is set to -25 dBm for the gain measurement (S_{21}) and the port 2 power is set to 0 dBm for the reverse isolation measurement (S_{12}).

3. Press **Chan 1** **Meas** **Trans:FWD S21 (B/R)** **Power** and set the power level for port 1.

4. Press **Chan 2** **Meas** **Trans: REV S12 (A/R)** **Power** and set the power level for port 2.

5. Perform an error-correction and connect the amplifier to the network analyzer. Refer to the [Chapter 5](#), "Optimizing Measurement Results," for error-correction procedures.

6. Press **Display** **DUAL | QUAD SETUP** **DUAL CHAN ON**.

You can view both measurements simultaneously by using the dual channel display mode. Refer to [Figure 1-46](#). If the port power levels are in different power ranges, one of the displayed measurements will not be continually updated and the annotation t_{SH} will appear on the left side of the display. Refer to "Source Attenuator Switch Protection" on [page 7-13](#) for information on how to override this state.

NOTE To obtain best accuracy, you should set the power levels prior to performing the calibration. However, the analyzer compensates for nominal power changes you make during a measurement, so that the error correction still remains quite valid. In these cases, the **Cor** annunciator will change to **CA**.

Figure 1-46 Gain and Reverse Isolation

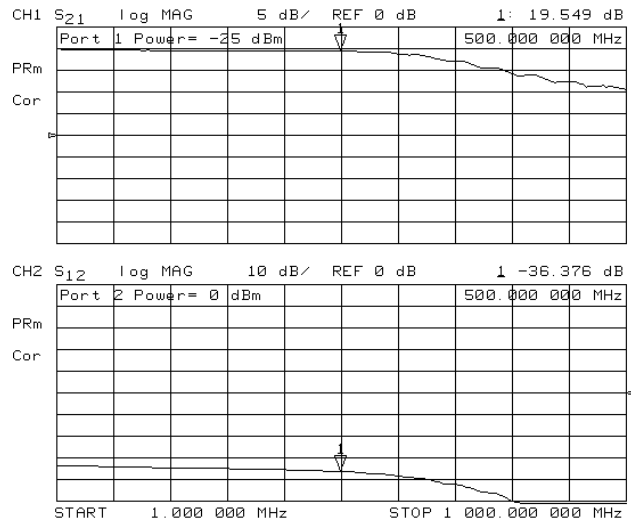

Making High Power Measurements with Option 085 (ES Analyzers Only)

Analyzers equipped with Option 085 can be configured to measure high power devices. This ability is useful if the required input power for a device under test is greater than the analyzer can provide, or if the maximum output power from an amplifier under test exceeds safe input limits for a standard analyzer. This section describes how to set up the analyzer to perform high power measurements.

Initial Setup

1. If the analyzer is in the bypass mode configuration, remove the jumper between the RF OUT and RF IN connector on the rear panel.
2. Connect the booster amplifier RF INPUT connector to the RF OUT connector on the rear panel of the analyzer.
3. Connect a 20 dB coupler (that operates within the frequency range of interest) to the booster amplifier RF OUTPUT connector.

Figure 1-47 High Power Test Setup (Step 1)

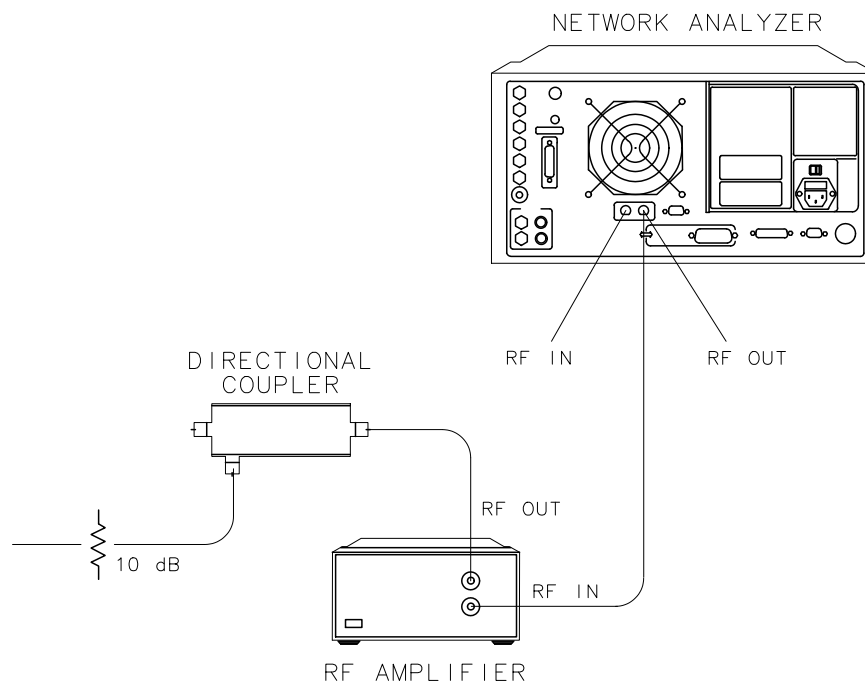

Determining Power Levels

Before continuing, save this state and rename it to UPRESET. To allow the preset mode to be set to user preset, press **Preset** **PRESET: USER**. The final state can then be resaved as a user preset to avoid an over-power condition from the factory preset.

4. Switch on the analyzer and reduce the power level to -20 dBm by pressing **Power** **PWR RANGE AUTO** **POWER RANGES** **-20** **x1**.
5. Switch on the booster amplifier.

- Using a power meter, measure the output power from the coupled arm and the open port of the coupler.

NOTE Depending on the power meter being used, additional attenuation may have to be added between the coupler port and the power meter.

- Verify the gain of the booster amplifier. For example, if the analyzer output power level was set to -20 dBm and the output power measured from the open end of the coupler was -5 dBm, then the gain of the booster amplifier would be $+15$ dB.
- Verify that the power measured in the previous steps is well within acceptable limits (less than -10 dBm for the coupled arm, less than $+43$ dBm for the open port).
- Estimate the maximum power level that will be needed to force the DUT into compression.
- At the maximum estimated power level, determine if the maximum output power from the coupled arm of the coupler will be higher than the acceptable limit. If so, add the appropriate amount of attenuation that will keep the coupled output power below -10 dBm and above -35 dBm.

Additional Setup

- Switch off the booster amplifier.
- Make a connection between the open port of the 20 dB coupler and the RF IN connector on the rear panel of the analyzer.
- Make a connection between the coupled arm of the 20 dB coupler (along with any added attenuation) and the R CHANNEL IN connector on the front panel.

Figure 1-48 High Power Test Setup (Step 2a)

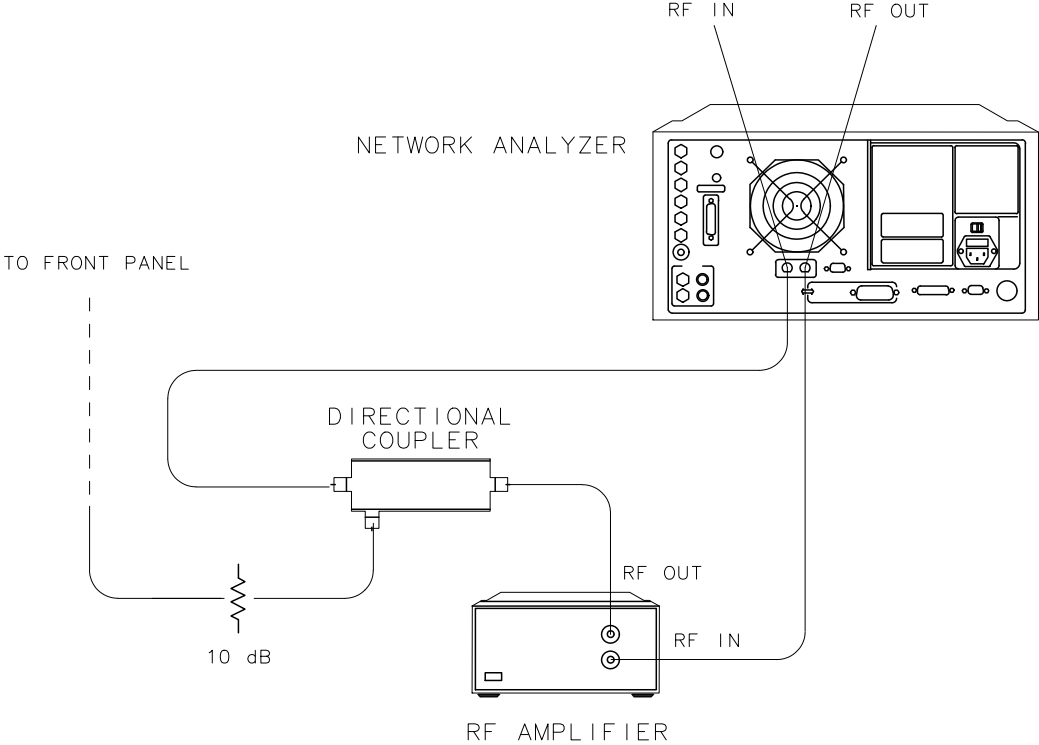
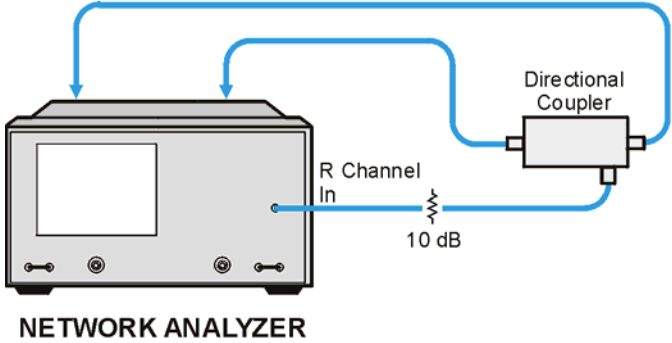

Figure 1-49 High Power Test Setup (Step 2b)



pa58e

Selecting Power Ranges and Attenuator Settings

14. Select a power range that will not exceed the maximum estimated power level that will force the DUT into compression. For example, if your booster amplifier has a gain of +15 dB and the DUT will compress if supplied with +20 dBm, then you would adjust the analyzer output power to not exceed +5 dBm by pressing **Power** **PWR RANGE MAN** **POWER RANGES** **RANGE 0 -15 TO +5** (**RANGE 0 -20 TO -5**, 8722ES).
15. Adjust the analyzer power level to be below the maximum limit of the power range by pressing **0** (or less) **x1**.

16. Estimate the maximum amount of gain that could be provided by the DUT and, as a result, the maximum amount of power that could be received by TEST PORT 2 when the DUT is in compression. For example, if a DUT with a maximum gain of +10 dB receives an input of +20 dBm, then the maximum amount of power that could be received by TEST PORT 2 is +30 dBm.

Figure 1-50 Internal Signal Paths of the Option 085 Analyzer

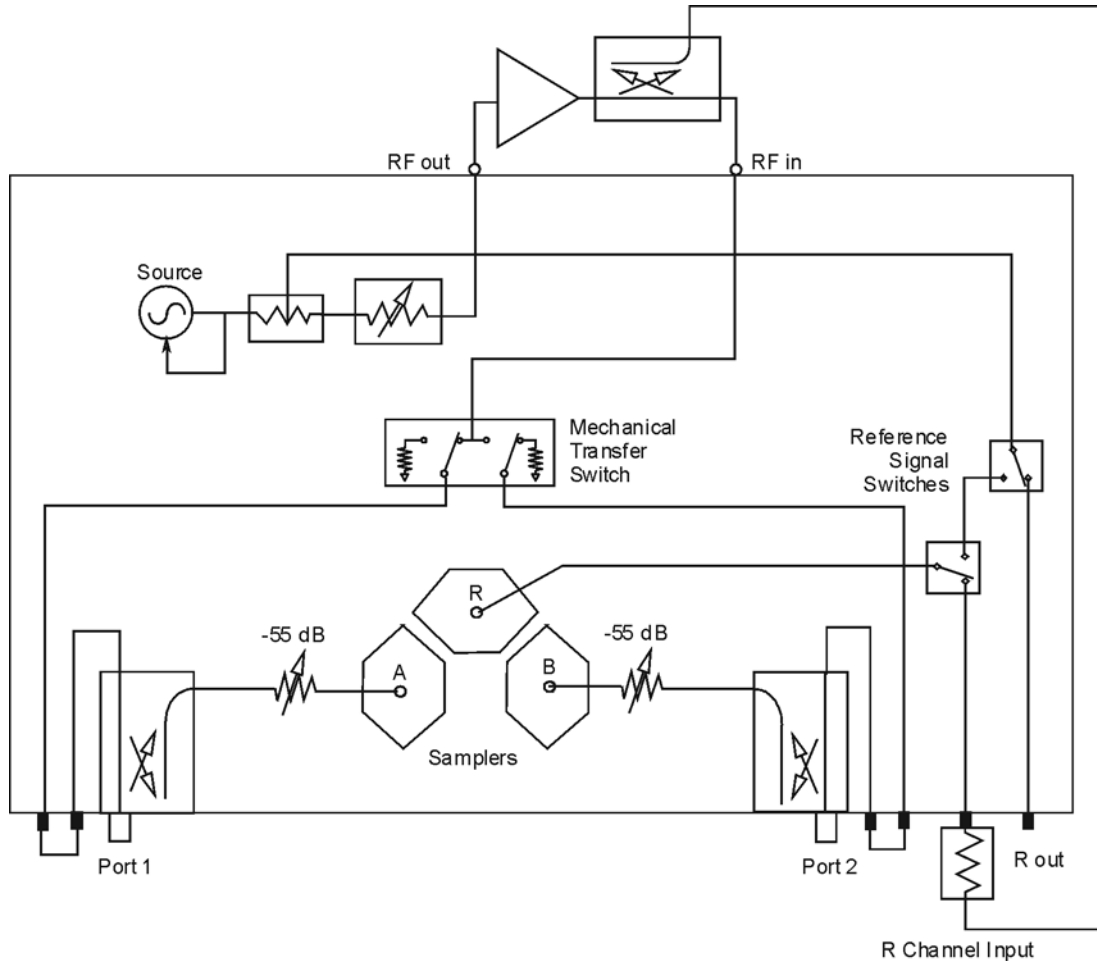

pa5179e

17. Calculate the amount of attenuation needed between the analyzer's couplers and samplers in order to not exceed the optimum sampler power level of -10 dBm.

In this example, it will be necessary to take the following into consideration:

- Sampler A will be coupled to the analyzer RF path that could receive power reflections as high as +20 dBm.
- Sampler B will be coupled to the analyzer RF path that will receive a maximum of +30 dBm from the DUT.
- Analyzer coupler loss is -13 dB.
- The optimum sampler power level is -10 dBm.

With the previous points in mind, the amount of attenuation can be calculated from the following equations:

- Attenuator A = +20 dBm – 13 dB – (–10 dBm). **Attenuator A = +17 dB**
- Attenuator B = +30 dBm – 13 dB – (–10 dBm). **Attenuator B = +27 dB**

18. Set the internal step attenuators to the values calculated in the previous step (rounding off to the highest 5 dB step). Press **Power** **ATTENUATOR A** **15** **x1** **ATTENUATOR B** **25** **x1**.

19. Switch on the booster amplifier.

CAUTION From this point forward, **DO NOT** press **Preset** unless you have first switched off the booster amplifier or saved this state and renamed it to UPRESET. Pressing **Preset** will return the analyzer to its default power level and default internal attenuator settings. This increase in power may result in damage to the DUT or analyzer.

20. To activate the external reference mode, press **System** **INSTRUMENT MODE** **EXT R CHAN ON**.

21. Measure the output power from test port 1 using a power meter and verify that it is as expected.

22. If you are measuring a highly reflective device, high power isolators should be inserted in place of the jumpers located between the two sets of front panel SWITCH and COUPLER connectors.

Final Setup

23. Confirm that all power and attenuator settings are correct, and set the following measurement parameters:

Meas **Trans: FWD S21 (B/R)**

24. Perform a response calibration:

- Connect the test port cables of the analyzer to form a *thru* configuration.
- Press **Cal** **CALIBRATE MENU** **RESPONSE** **THRU**.

25. Make the connections as shown in [Figure 1-51](#). Switch on the DUT and measure the S_{21} gain of the amplifier under test to confirm the proper operation of the measurement test setup.

Figure 1-51 High Power Test Setup (Step 3)

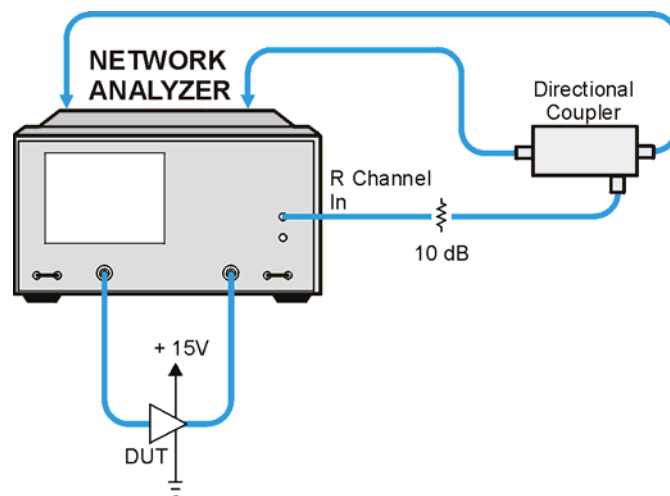

pa59e

26. Make any other desired high power measurements.

Ratio measurements such as gain will be correctly displayed. However, the displayed absolute power levels on the analyzer will not be correct. To correctly interpret power levels, the gain of the booster amplifier and the attenuator settings must be taken into consideration.

NOTE If no calibration has been performed or if the instrument is in an uncalibrated state, the following must be taken in consideration when interpreting the measured data:

- The value of attenuation added to sampler A and B.
 - The R channel reference level supplied from the coupled arm of the 20 dB coupler.
-

Making High Power Measurements with Option 012 (ES Analyzers Only)

Analyzers equipped with Option 012 can be configured to measure devices that have high power outputs. With direct sampler access, you can insert attenuators between the couplers and samplers, protecting the samplers from excessive power.

Figure 1-52 Internal Signal Paths of the Option 012 Analyzer

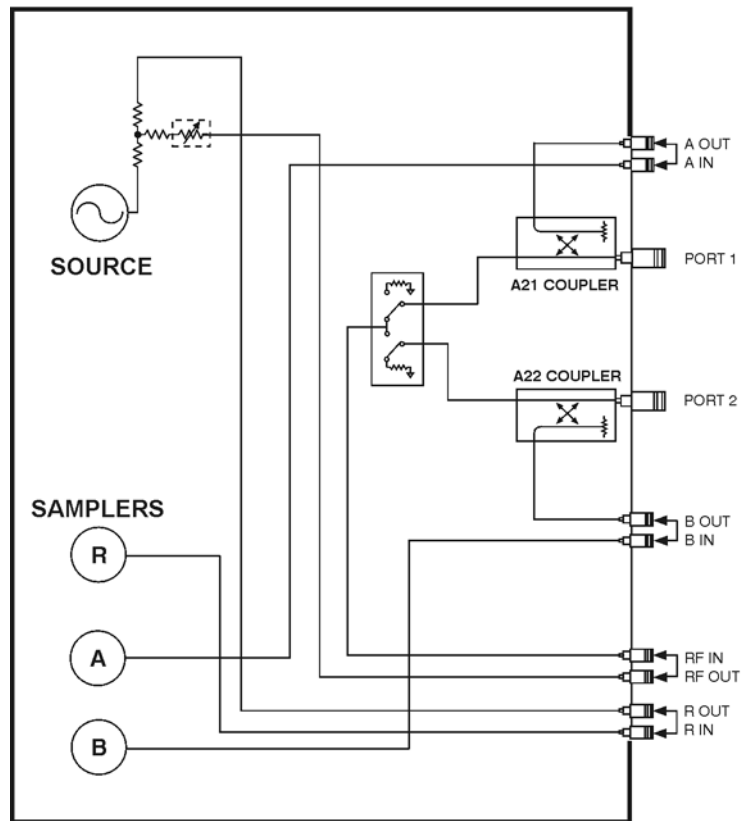

pa512e

1. Estimate the maximum amount of gain that could be provided by the DUT and, as a result, the maximum amount of power that could be received by test port 2. For example, if a DUT with a maximum gain of +15 dB receives an input of +5 dBm, then the maximum amount of power that could be received by test port 2 is +20 dBm.
2. Calculate the amount of attenuation needed between the analyzer's coupler and sampler in order to not exceed the optimum sampler power level of -10 dBm.

In this example, it will be necessary to take the following into consideration:

- Sampler B will be coupled to the analyzer RF path that will receive a maximum of +20 dBm from the DUT.
- Analyzer coupler loss is -13 dB.
- The optimum sampler power level is -10 dBm.

Making Measurements

Measuring Amplifiers

With the previous points in mind, the amount of attenuation can be calculated from the following equations:

- Attenuator value = $+20 \text{ dBm} - 13 \text{ dB} - (-10 \text{ dBm})$. **Attenuator Value = +17 dB**
3. Choose the S21 measurement parameter by pressing **Meas** **Trans: FWD S21 (B/R)**.
 4. Connect the attenuator between the B OUT and IN ports.
 5. Perform a calibration.
 6. Connect the DUT as shown in [Figure 1-53](#) and view the measurement.

Figure 1-53 Option 012 High Power Configuration

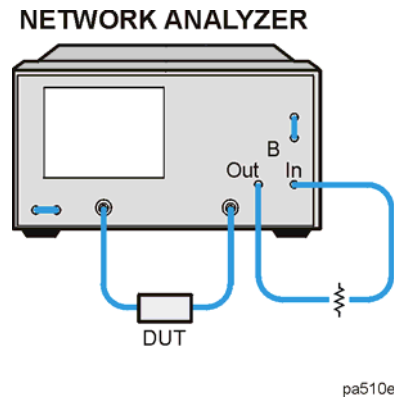

Using the Swept List Mode to Test a Device

When using a list frequency sweep, the analyzer has the ability to sweep arbitrary frequency segments, each containing a list of frequency points. One major advantage of using list frequency sweep is that it allows you to measure the minimum number of data points, and only at the frequencies of interest. This serves to minimize the overall test time. Two different list frequency sweep modes can be selected:

Stepped List

Mode

In this mode, the source steps to each defined frequency point, stopping while data is taken. This mode eliminates IF delay and allows frequency segments to overlap. However, the sweep time is substantially slower than for a continuous sweep with the same number of points.

Swept List

Mode

This mode takes data while sweeping through the defined frequency segments, increasing throughput by up to 6 times over a stepped sweep. In addition, this mode allows the test port power and IF bandwidth to be set independently for each segment that is defined. The frequency segments in this mode cannot overlap.

The ability to completely customize the frequency sweep while using swept list mode is useful when setting up a measurement for a device with high dynamic range, like a filter. The following measurement of a filter illustrates the advantages of using the swept list mode.

- For in-depth information on swept list mode, refer to "[Swept List Frequency Sweep \(Hz\)](#)" on page 7-17.
- For information on optimizing your measurement results when using swept list mode, refer to "[To Use Swept List Mode](#)" on page 5-10.

Connect the Device Under Test

1. Connect the equipment as shown in [Figure 1-54](#).

Figure 1-54 Swept List Measurement Setup

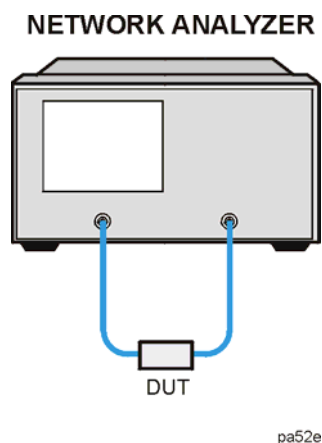

2. Set the following measurement parameters:

Meas **Trans: FWD S21 (B/R)** or on ET models: **TRANSMISSN**

Center 900 M/μ
Span 500 M/μ

Observe the Characteristics of the Filter

Figure 1-55 Characteristics of a Filter

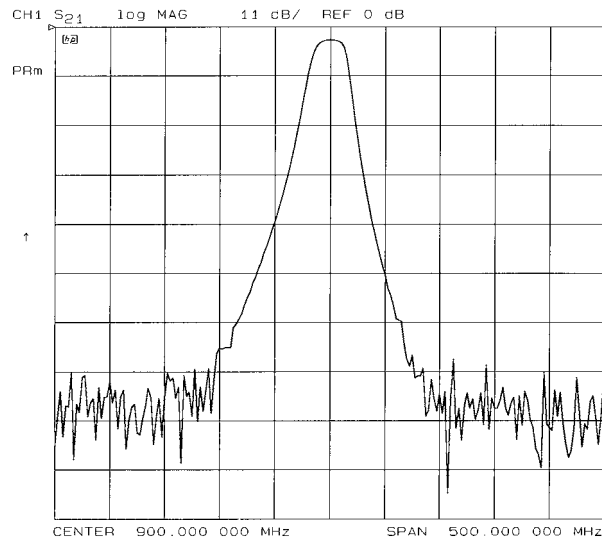

pa5110e

- Generally, the passband of a filter exhibits low loss. A relatively low incident power may be needed to avoid overdriving the next stage of the DUT (if that stage contains an amplifier) or the network analyzer receiver.
- Conversely, the stopband of a filter generally exhibits high isolation. To measure this characteristic, the dynamic range of the system will have to be maximized. This can be done by increasing the incident power and narrowing the IF bandwidth.

Choose the Measurement Parameters

1. Decide the frequency ranges of the segments that will cover the stopbands and passband of the filter. For this example, the following ranges will be used:
 - Lower stopband: 650 to 880 MHz
 - Passband: 880 to 920 MHz
 - Upper stopband: 920 to 1150 MHz
2. To set up the swept list measurement, press:

Sweep Setup SWEEP TYPE MENU EDIT LIST

Set Up the Lower Stopband Parameters

3. To set up the segment for the lower stopband, press

ADD

START

STOP

NUMBER of POINTS

4. To maximize the dynamic range in the stopband (increasing the incident power and narrowing the IF bandwidth), press

MORE

LIST POWER ON off until ON is selected **SEGMENT POWER**

LIST IF BW ON off until ON is selected **SEGMENT IF BW**

RETURN **DONE**

Set Up the Passband Parameters

5. To set up the segment for the passband, press

ADD

CENTER

SPAN

STEP SIZE

6. To specify a lower power level and a wider IF bandwidth for the passband, press

MORE

SEGMENT POWER

SEGMENT IF BW

RETURN **DONE**

Set Up the Upper Stopband Parameters

7. To set up the segment for the upper stopband, press

ADD

START

STOP

NUMBER of POINTS

- To maximize the dynamic range in the stopband (increasing the incident power and narrowing the IF bandwidth), press:

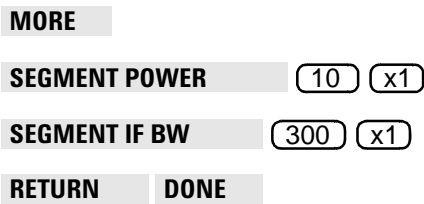

- Press **DONE** **LIST FREQ [SWEPT]**.

Calibrate and Measure

- Remove the DUT and perform a full two-port calibration. Refer to [Chapter 6](#), “Calibrating for Increased Measurement Accuracy.”
- With the thru connected, set the scale to autoscale to observe the benefits of using swept list mode.
 - The segments used to measure the stopbands have less noise, thus maximizing dynamic range within the stopband frequencies.
 - The segment used to measure the passband has been set up for faster sweep speed with more measurement points.

Figure 1-56 Calibrated Swept List Thru Measurement

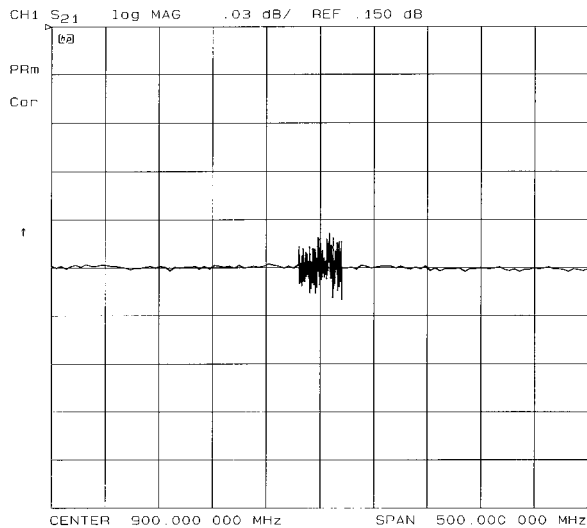

pa5111e

- Reconnect the filter and adjust the scale to compare results with the first filter measurement that used a linear sweep.

In [Figure 1-57](#), notice that the noise level has decreased over 10 dB, confirming that the noise reduction techniques in the stopbands were successful. Also, notice that the stopband noise in the third segment is slightly lower than in the first segment. This is due to the narrower IF bandwidth of the third segment (300 Hz).

Figure 1-57 Filter Measurements Using Linear Sweep and Swept List Mode

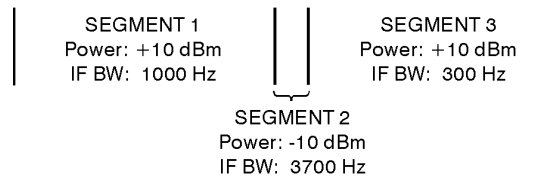
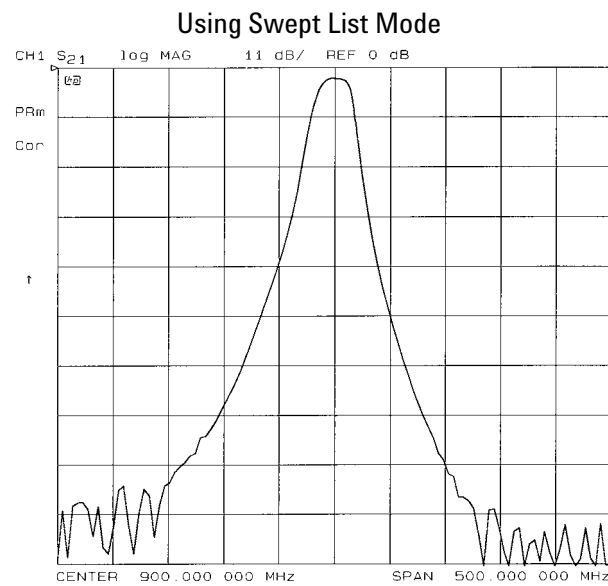
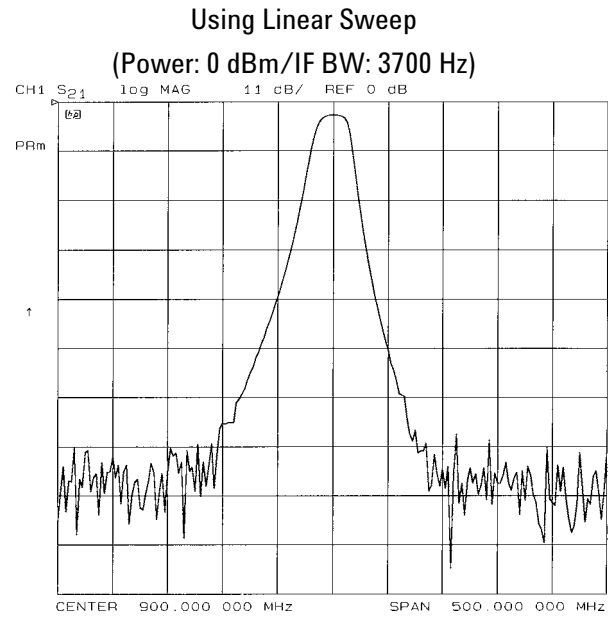

Using Limit Lines to Test a Device

Limit testing is a measurement technique that compares measurement data to constraints that you define. Depending on the results of this comparison, the analyzer will indicate if your device either passes or fails the test.

Limit testing is implemented by creating individual flat, sloping, and single-point limit lines on the analyzer display. When combined, these lines can represent the performance parameters for your device under test. The limit lines created on each measurement channel are independent of each other.

This example measurement shows you how to test a bandpass filter using the following procedures:

- creating flat limit lines
- creating sloping limit lines
- creating single point limit lines
- editing limit segments
- running a limit test

Setting Up the Measurement Parameters

1. Connect your test device as shown in [Figure 1-58](#).

Figure 1-58 Connections for SAW Filter Example Measurement

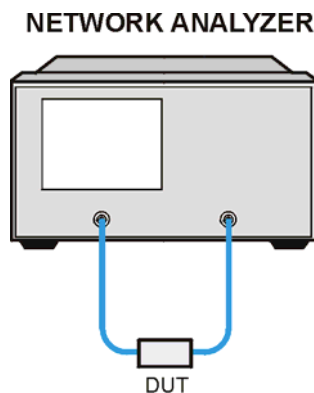

pa52e

2. Press **Preset** and choose the measurement settings. For this example the measurement settings are as follows:

- **Meas** **Trans: FWD S21 (B/R)** or on ET models: **TRANSMISSN**
- **Center** **134** **M/μ**
- **Span** **50** **M/μ**
- **Scale Ref** **AUTO SCALE**

You may also want to select settings for the number of data points, power, averaging, and IF bandwidth.

3. Substitute a thru for the device and perform a response calibration by pressing:

Cal **CALIBRATE MENU** **RESPONSE** **THRU**

- Reconnect your test device.
- To better view the measurement trace, press:

Scale Ref **AUTO SCALE**

Creating Flat Limit Lines

In this example procedure, the following flat limit line values are set:

Frequency Range	Power Range
127 MHz to 140 MHz	-27 dB to -21 dB
100 MHz to 123 MHz	-200 dB to -65 dB
146 MHz to 160 MHz	-200 dB to -65 dB

NOTE The minimum value for measured data is -200 dB.

- To access the limits menu and activate the limit lines, press:

System **LIMIT MENU** **LIMIT LINE** **LIMIT LINE ON** **EDIT LIMIT LINE**
CLEAR LIST **YES**

- To create a new limit line, press:

ADD

The analyzer generates a new segment that appears on the center of the display.

- To specify the limit's stimulus value, test limits (upper and lower), and the limit type, press:

STIMULUS VALUE **127** **M/μ**
UPPER LIMIT **-21** **x1**
LOWER LIMIT **-27** **x1** **DONE**

NOTE You could also set the upper and lower limits by using the **MIDDLE VALUE** and **DELTA LIMITS** keys. To use these keys for the entry, press:

MIDDLE VALUE **-24** **x1** **DELTA LIMITS** **3** **x1**

This would correspond to a test specification of -24 ± 3 dB.

- To define the limit as a flat line, press:

LIMIT TYPE **FLAT LINE** **RETURN**

Making Measurements
Using Limit Lines to Test a Device

5. To terminate the flat line segment by establishing a single point limit, press:

ADD **STIMULUS VALUE** **DONE**
LIMIT TYPE **SINGLE POINT** **RETURN**

Figure 1-59 shows the flat limit lines that you have just created with the following parameters:

- stimulus from 127 MHz to 140 MHz
- upper limit of -21 dB
- lower limit of -27 dB

Figure 1-59 Example Flat Limit Line

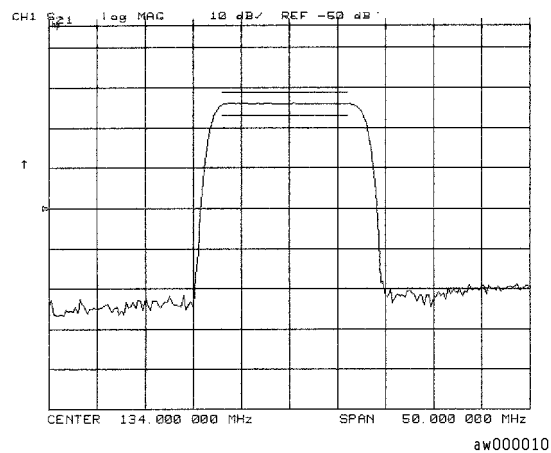

• To create a limit line that tests the low side of the filter, press:

ADD
STIMULUS VALUE
UPPER LIMIT
LOWER LIMIT
DONE
LIMIT TYPE **FLAT LINE** **RETURN**
ADD
STIMULUS VALUE
DONE
LIMIT TYPE **SINGLE POINT** **RETURN**

- To create a limit line that tests the high side of the bandpass filter, press:

```

ADD
STIMULUS VALUE 146 M/μ
UPPER LIMIT -65 x1
LOWER LIMIT -200 x1
DONE
LIMIT TYPE FLAT LINE RETURN
ADD
STIMULUS VALUE 160 M/μ
DONE
LIMIT TYPE SINGLE POINT RETURN
    
```

Figure 1-60 Example Flat Limit Lines

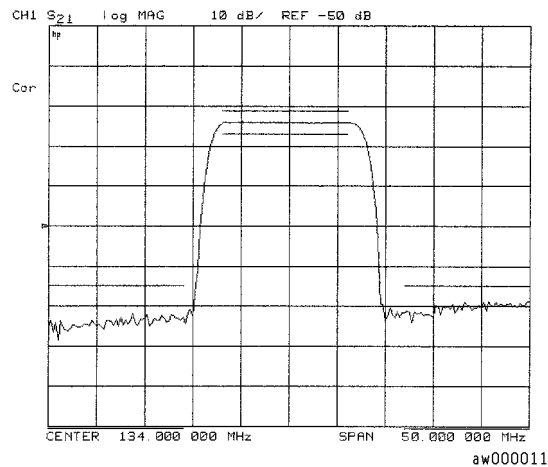

Creating a Sloping Limit Line

This example procedure shows you how to make limits that test the shape factor of a SAW filter. The following limits are set:

Frequency Range	Power Range
123 MHz to 125 MHz	-65 dB to -26 dB
144 MHz to 146 MHz	-26 dB to -65 dB

Making Measurements
Using Limit Lines to Test a Device

1. To access the limits menu and activate the limit lines, press:

System **LIMIT MENU** **LIMIT LINE** **LIMIT LINE ON** **EDIT LIMIT LINE**
CLEAR LIST **YES**

2. To establish the start frequency and limits for a sloping limit line that tests the low side of the filter, press:

ADD **STIMULUS VALUE** **123** **M/μ**
UPPER LIMIT **-65** **x1** **LOWER LIMIT** **-200** **x1**
DONE **LIMIT TYPE** **SLOPING LINE** **RETURN**

3. To terminate the lines and create a sloping limit line, press:

ADD **STIMULUS VALUE** **125** **M/μ**
UPPER LIMIT **-26** **x1** **LOWER LIMIT** **-200** **x1**
DONE **LIMIT TYPE** **SINGLE POINT** **RETURN**

4. To establish the start frequency and limits for a sloping limit line that tests the high side of the filter, press:

ADD **STIMULUS VALUE** **144** **M/μ**
UPPER LIMIT **-26** **x1** **LOWER LIMIT** **-200** **x1**
DONE **LIMIT TYPE** **SLOPING LINE** **RETURN**

5. To terminate the lines and create a sloping limit line, press:

ADD **STIMULUS VALUE** **146** **M/μ**
UPPER LIMIT **-65** **x1** **LOWER LIMIT** **-200** **x1**
DONE **LIMIT TYPE** **SINGLE POINT** **RETURN**

You could use this type of limit to test the shape factor of a filter.

Figure 1-61 Sloping Limit Lines

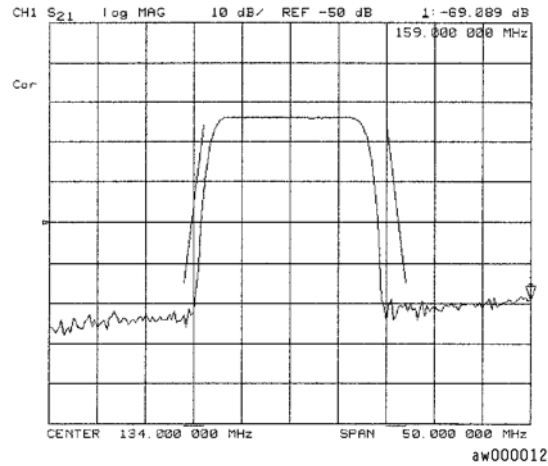

Creating Single Point Limits

In this example procedure, the following limits are set:

- from -23 dB to -28.5 dB at 141 MHz
- from -23 dB to -28.5 dB at 126.5 MHz

1. To access the limits menu and activate the limit lines, press:

System **LIMIT MENU** **LIMIT LINE** **LIMIT LINE ON** **EDIT LIMIT LINE**
CLEAR LIST **YES**

2. To designate a single point limit line, as shown in Figure 1-62, you must define two pointers:

- downward pointing, indicating the upper test limit
- upward pointing, indicating the lower test limit

Press:

ADD **STIMULUS VALUE** **141** **M/μ**
UPPER LIMIT **-23** **x1** **LOWER LIMIT** **-28.5** **x1** **DONE**
LIMIT TYPE **SINGLE POINT** **RETURN**
ADD **STIMULUS VALUE** **126.5** **M/μ**
UPPER LIMIT **-23** **x1**
LOWER LIMIT **-28.5** **x1** **DONE**
LIMIT TYPE **SINGLE POINT** **RETURN**

Figure 1-62 Example Single Points Limit Line

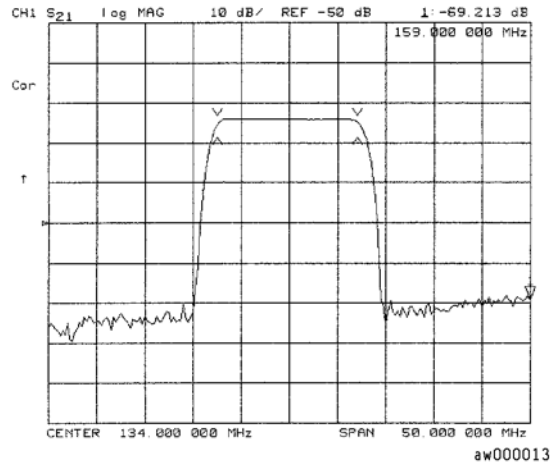

Editing Limit Segments

This example shows you how to edit the upper limit of a limit line.

1. To access the limits menu and activate the limit lines, press:

System **LIMIT MENU** **LIMIT LINE** **LIMIT LINE ON** **EDIT LIMIT LINE**

2. To move the pointer symbol (>) on the analyzer display to the segment you wish to modify, press:

SEGMENT  or  repeatedly OR **SEGMENT** and enter the segment number followed by **x1**.

3. To change the upper limit (for example, -20) of a limit line, press:

EDIT **UPPER LIMIT** **-20** **x1** **DONE**

Deleting Limit Segments

1. To access the limits menu and activate the limit lines, press:

System **LIMIT MENU** **LIMIT LINE** **LIMIT LINE ON** **EDIT LIMIT LINE**

2. To move the pointer symbol (>) on the analyzer display to the segment you wish to delete, press:

SEGMENT  or  repeatedly OR **SEGMENT** and enter the segment number followed by **x1**.

3. To delete the segment that you have selected with the pointer symbol, press:

DELETE

Running a Limit Test

1. To access the limits menu and activate the limit lines, press:

System **LIMIT MENU** **LIMIT LINE** **LIMIT LINE ON** **EDIT LIMIT LINE**

Reviewing the Limit Line Segments

The limit table data that you have previously entered is shown on the analyzer display.

- To verify that each segment in your limits table is correct, review the entries by pressing:

SEGMENT  and 

- To modify an incorrect entry, refer to the [“Editing Limit Segments”](#) procedure, located earlier in this section.

Activating the Limit Test

To activate the limit test and the beep fail indicator, press:

System **LIMIT MENU** **LIMIT LINE** **LIMIT TEST ON** **BEEP FAIL ON**

NOTE Selecting the beep fail indicator **BEEP FAIL ON** is optional and will add approximately 50 ms of sweep cycle time. Because the limit test will still work if the limits lines are off, selecting **LIMIT LINE ON** is also optional.

The limit test results appear on the right side on the analyzer display. The analyzer indicates whether the filter passes or fails the defined limit test:

- The message **FAIL** will appear on the right side of the display if the limit test fails.
- The analyzer beeps if the limit test fails and if **BEEP FAIL ON** has been selected.
- The analyzer changes the color of the trace to flashing red where the measurement trace is out of limits.
- A TTL signal on the rear panel BNC connector "LIMIT TEST" provides a pass/fail (5 V/0 V) indication of the limit test results.

Offsetting Limit Lines

The limit offset functions allow you to adjust the limit lines to the frequency and output level of your device. For example, you could apply the stimulus offset feature for testing tunable filters. Or, you could apply the amplitude offset feature for testing variable attenuators, or passband ripple in filters with variable loss.

This example shows you the offset feature and the limit test failure indications that can appear on the analyzer display.

Making Measurements
Using Limit Lines to Test a Device

- To offset all of the segments in the limit table by a fixed frequency, (for example, 3 MHz), press:

System **LIMIT MENU** **LIMIT LINE** **LIMIT LINE OFFSETS** **STIMULUS OFFSET**
3 **M/μ**

The analyzer beeps and a FAIL notation appears on the analyzer display, as shown in [Figure 1-63](#).

Figure 1-63 Example Stimulus Offset of Limit Lines

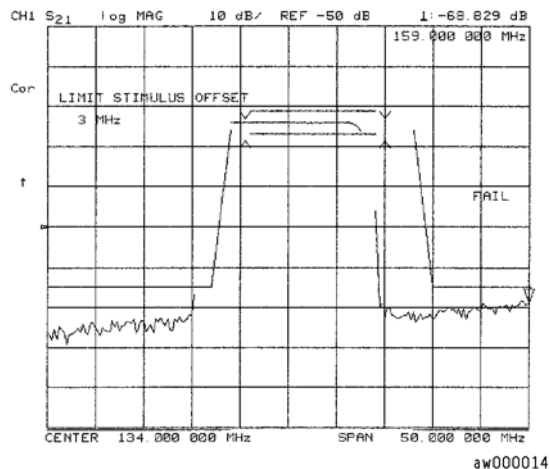

- To return to 0 Hz offset, press:

STIMULUS OFFSET **0** **x1**

- To offset all of the segments in the limit table by a fixed amplitude, press:

AMPLITUDE OFFSET **5** **x1**

The analyzer beeps and a FAIL notation appears on the analyzer display.

- To return to 0 dB offset, press:

AMPLITUDE OFFSET **0** **x1**

- To offset the amplitude offset value by the active marker reading, press **MARKER → AMP. OFS.**. Pressing **AMPLITUDE OFFSET** shows the current value.

Using Ripple Limits to Test a Device

Setting Up the List of Ripple Limits to Test

Two tasks are involved in preparing for ripple testing:

- First, set up the analyzer settings to view the frequency of interest.
- Second, set up the analyzer to test over the appropriate frequencies against your specific limits.

This example will show you how to set up the analyzer to test ripple limits. In this example, we will be testing the pass band of a bandpass filter where the center frequency of the filter is approximately 1.8 GHz and has a bandwidth of approximately 2.9 GHz. Refer to [Figure 1-64](#).

Figure 1-64 Bandpass Filter Being Ripple Tested

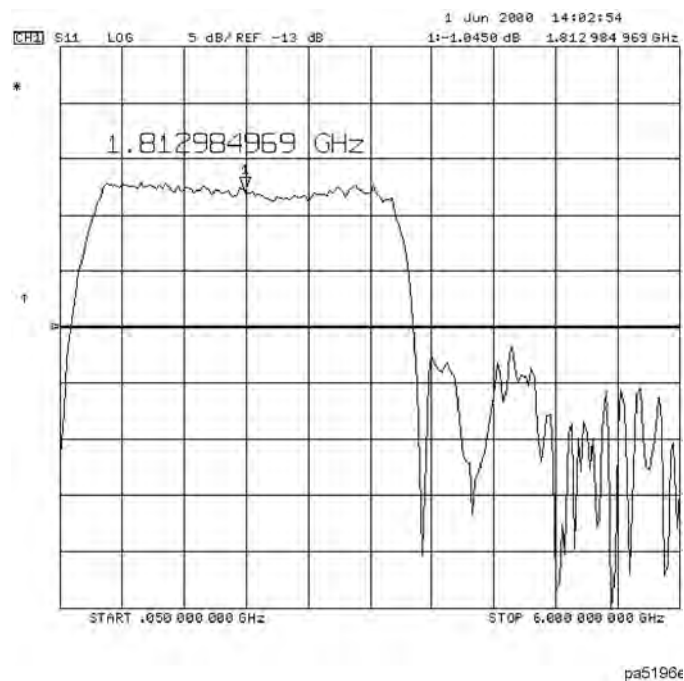

Setting Up the Analyzer to Perform the Ripple Test

This section sets up the analyzer so that a bandpass filter can be easily viewed on the analyzer display.

1. Connect your filter as shown in [Figure 1-65](#).

Figure 1-65 Connections for an Example Ripple Test Measurement

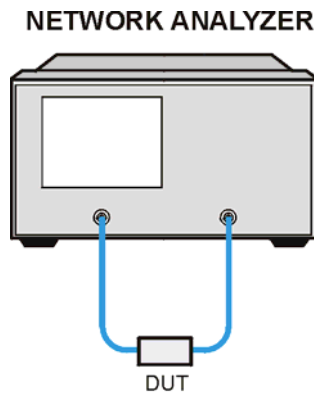

pa52e

2. Press **Preset** and choose the measurement settings. For this example, the measurement settings are as follows:

- **Meas** **Trans: FWD S21 (B/R)** or on ET models: **TRANSMISSN**
- **Center** **1.8** **G/n**
- **Span** **3.4** **G/n**
- **Scale Ref** **AUTO SCALE**

You may also want to select settings for the number of data points, power, averaging, and IF bandwidth.

3. Substitute a thru for the device and perform a response calibration by pressing:

Cal **CALIBRATE MENU** **RESPONSE** **THRU**

4. Reconnect your test device.

5. To better view the measurement trace, press **Scale Ref** **AUTO SCALE**. Refer to [Figure 1-66](#).

Figure 1-66 Filter Pass Band Before Ripple Test

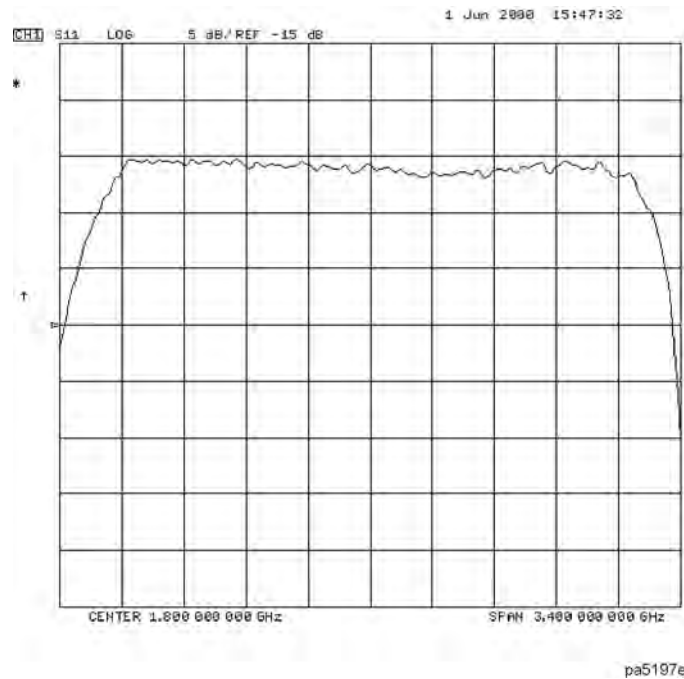

Setting Up Limits for Ripple Testing

This section instructs you on setting up the ripple test parameters. You must set up the analyzer to check the DUT at the correct frequencies and compare the measured values against the maximum allowable ripple value for each frequency band. To do this, you set up individual frequency bands. You define the stop and start frequency and the maximum allowable ripple value of each frequency band. You may set up as many as 12 frequency bands for testing ripple. The frequency bands are combined in a list that is displayed while the ripple frequency bands are being edited.

In this example, we will create one ripple limit (or frequency band) that spans the entire pass band from 500 MHz to 3.0 GHz. We will also create two additional frequency bands that when merged, will span the pass band with tighter limits. Using the Ripple Edit Menu, we will create a ripple limits list on the analyzer that is similar to the following table.

Table 1-3 Ripple Limits for Ripple Test Example

Frequency Band	Minimum Frequency	Maximum Frequency	Maximum Ripple
1	500 MHz	3.2 GHz	2.0 dB
2	500 MHz	1.85 GHz	1.3 dB
3	1.85 GHz	3.2 GHz	1.3 dB

Notice that Frequency Band 1 overlaps in frequency the remaining frequency bands. Whereas, Frequency Bands 2 and 3 are separate bands that cover the same span of frequency. This can be done to put tighter limits over narrower frequency spans within the bandpass or to customize the ripple test to meet your specific requirements.

1. To access the ripple test menu, press:

System **LIMIT MENU** **RIPPLE LIMIT**

2. To access the ripple test edit menu, press **EDIT RIPL LIMIT**.

3. Add the first frequency band (Frequency Band 1) to be tested by pressing **ADD**.

4. Set the lower frequency value of Frequency Band 1 by pressing:

MINIMUM FREQUENCY **500** **M/μ**

5. Set the upper frequency value of Frequency Band 1 by pressing:

MAXIMUM FREQUENCY **3.2** **G/n**

6. Set the maximum allowable ripple amplitude value of Frequency Band 1 by pressing:

MAXIMUM RIPPLE **2.0** **x1**

7. Repeat steps 3 through 6 for the two remaining frequency bands to be tested for maximum ripple.

The network analyzer allows you to enter up to 12 frequency bands to be tested for maximum ripple.

8. After you have entered all of the ripple test frequency band parameters, return to the ripple test menu by pressing **DONE**.

Editing Ripple Test Limits

Once the frequency band limits for ripple testing have been created, the limits may be changed using the same menu that was used to create them. Using the edit ripple test menu, you may:

- Change existing frequency band limits
- Add more frequency band limits
- Delete individual frequency band limits
- Clear all frequency band limits

Changing Existing Frequency Band Limits

Existing frequency band limits may be changed for testing the ripple. This procedure guides you through changing the existing frequency band limits.

1. To access the ripple test edit menu from the ripple test menu, press:

EDIT RIPL LIMIT

2. Enter the frequency band whose limits you want to change by pressing:

a. **FREQUENCY BAND**

b. The numeric key indicating the frequency band number that you are changing.

The frequency band number is located in the left column of the list of frequency bands.

3. Make the changes to the selected band by pressing:
 - a. **MINIMUM FREQUENCY** and the new value to change the lower frequency of the frequency band.
 - b. **MAXIMUM FREQUENCY** and the new value to change the upper frequency of the frequency band.
 - c. **MAXIMUM RIPPLE** and the new decibel value to change the maximum allowable ripple of the frequency band. Terminate the new decibel value with the $\boxed{\times 1}$ key.
4. Repeat steps 2 and 3 for additional frequency bands.
5. After you have entered the necessary changes to the ripple test frequency band parameters, return to the ripple test menu by pressing **DONE**.

Adding Additional Frequency Bands

More frequency band limits may be added for testing the ripple. This procedure guides you through adding the more frequency band limits.

The network analyzer allows you to enter up to 12 frequency bands for maximum ripple testing.

1. To access the ripple test edit menu, press **EDIT RIPL LIMIT**.
2. Create a new frequency band by pressing **ADD**.
3. Set the lower frequency value of the frequency band by pressing:
 - a. **MINIMUM FREQUENCY**
 - b. the numeric keys indicating the minimum frequency value of the frequency band
 - c. the appropriate frequency key (either $\boxed{G/n}$, $\boxed{M/\mu}$, or $\boxed{k/m}$)
4. Set the upper frequency value of the frequency band by pressing:
 - a. **MAXIMUM FREQUENCY**
 - b. the numeric keys indicating the maximum frequency value of the frequency band
 - c. the appropriate frequency key (either $\boxed{G/n}$, $\boxed{M/\mu}$, or $\boxed{k/m}$)
5. Set the maximum allowable ripple amplitude value of the frequency band by pressing:
 - a. **MAXIMUM RIPPLE**
 - b. the decibel value of the frequency band's maximum allowable ripple
 - c. $\boxed{\times 1}$
6. Repeat steps 2 through 5 for additional frequency bands to be tested for maximum ripple.
7. After you have added all of the new frequency bands, return to the ripple test menu by pressing **DONE**.

Deleting Existing Frequency Bands

Frequency band limits may be deleted for testing the ripple. This procedure guides you through deleting

existing frequency band limits. You may delete individual frequency bands or delete all of the frequency bands from the list.

1. To access the ripple test edit menu, press:

EDIT RIPL LIMIT

2. Select the first frequency band (as an example, Frequency Band 3) to be deleted by pressing:

FREQUENCY BAND **3** **x1** **DELETE**

3. Repeat step 2 until you have deleted the required frequency bands from the list.
4. If you need to delete all of the frequency bands, you can delete them all by pressing:

CLEAR LIST

When this softkey is pressed, you will be asked to confirm that you want to delete all of the frequency bands from the list.

5. After you have finished deleting the frequency bands, you can return to the ripple test menu by pressing

DONE.

Running the Ripple Test

Once the list of ripple limits has been set up, you are ready to run the ripple test. From the Ripple Test Menu, you can:

- Start and stop the ripple test.
- Display and hide the ripple test limit lines.
- Select a frequency band and display its ripple measurement in two ways:
 - the absolute measured ripple value
 - the margin which the measured ripple passes or fails the user-defined maximum ripple value

Starting and Stopping the Ripple Test

Once the list of ripple limits has been set up, start the ripple test by pressing **RIPL TEST on OFF** from the Ripple Test Menu until ON is displayed on the softkey. Pressing this softkey toggles the analyzer between ripple test on and ripple test off status. [Figure 1-67](#) shows the filter pass band (with the scale changed to 1 dB/division) being ripple tested. Note that the filter fails the ripple test. The portions of the pass band trace which do not meet the test requirements are displayed in red.

Figure 1-67 Filter Passband with Ripple Test Activated

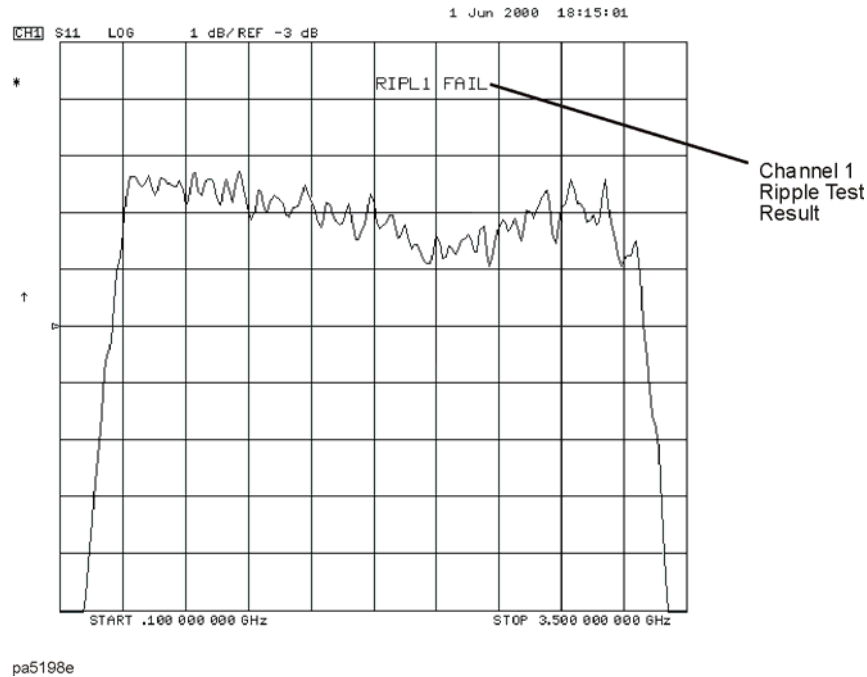

As the analyzer measures the ripple, a message is displayed indicating whether the measurement passes or fails:

- If the ripple test passes, a **RIPL n PASS** message (where n = the channel number) is displayed in the color assigned to Channel 1 Memory. The ripple test must pass in *all* frequency bands before the pass message is displayed.
- If the ripple test fails, a **RIPL n FAIL** message (where n = the channel number) is displayed in red. The portion of the trace that exceeds the user-specified maximum ripple value is also displayed in red.

Displaying the Ripple Limits

After the list of ripple limits has been set up, display the ripple test limits by pressing

RIPL LIMIT on OFF from the Ripple Test Menu until ON is displayed on the softkey. Pressing this softkey toggles the analyzer ripple limits display on and off. If the ripple limits are displayed and the ripple test is off, the ripple limits are displayed near the top of the graticule and are not compared with the displayed trace. However, once the ripple test is started, the ripple limits are displayed with respect to the measured trace in the following manner:

- If the ripple test passes, the ripple limits are drawn on the display for each frequency band. Within each frequency band, an upper and lower ripple limit is drawn such that they are equidistant above the upper point of the measured trace and below the lower point of the measured trace.

- If the ripple test fails, the ripple limits are drawn on the display for each frequency band. Within each frequency band, the lower ripple limit is drawn at the lowest point on the measured trace and the upper ripple limit is drawn at the user-specified maximum ripple value above the lower ripple limit. The ripple that exceeds the maximum ripple value extends above the upper limit. This measured trace that extends above the upper limit is displayed in red.

Figure 1-68 shows the filter pass band tested with the ripple limits activated. Notice that there are three sets of ripple limits shown. Also notice that the measured trace exceeds the upper ripple limit only in Frequency Band 3.

Figure 1-68 Filter Pass Band with Ripple Test and Ripple Limits Activated

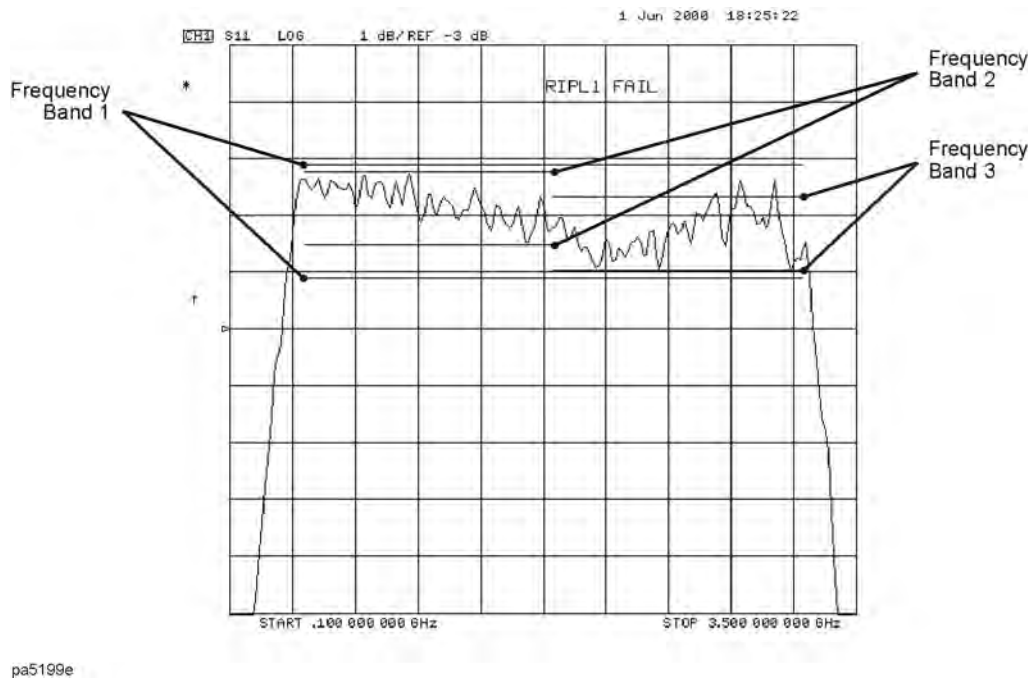

Changing the Ripple Limits Line Color. The color of the lines that represent the ripple limits can be changed by:



1. pressing the **Display** key
2. pressing **MORE** **ADJUST DISPLAY** **MODIFY COLORS** **MORE**
3. pressing **RIPPLE LIM LINES** **TINT** and turning the analyzer front panel knob until the desired color appears (You may also use the step keys or the numeric keypad instead of the front panel knob to change the color.)

Checking the Ripple Value

Once the ripple test has been started and is running, you may display the ripple value of each frequency band in one of two formats, the *absolute* format or the *margin* format. Both formats are described in this section.

To display the ripple value, press **RIPL VALUE []**. Pressing this softkey toggles between **RIPL VALUE [OFF]**, **RIPL VALUE [ABSOLUTE]**, and **RIPL VALUE [MARGIN]**. Pressing **RIPL TEST on OFF** from the Ripple Test Menu until ON is displayed on the softkey. Pressing this softkey toggles the analyzer between ripple test on and ripple test off status.

When the Absolute and Margin choices are selected, the frequency band and measurement value are displayed to the right side of the pass/fail message described previously. This display is displayed in the same color as the pass/fail message.

The frequency band of the displayed value is displayed as **Bn** (where *n* = the frequency band number). The frequency band may be changed to display the value of each band. To change the displayed frequency band value, from the Ripple Test Menu press **RIPL VALUE BAND** and then use the  and  keys (or the numerical keypad) to select the desired frequency band.

Viewing the Ripple Value in Absolute Format

When **RIPL VALUE [ABSOLUTE]** is selected, the absolute ripple value of the selected frequency band is displayed. The absolute ripple value is the measured maximum level minus the measured minimum level within the frequency band. This value is displayed in dB.

Figure 1-69 shows the ripple test with absolute ripple value displayed for Frequency Band 1. The **B1** indicates that the ripple value displayed is for Frequency Band 1. Notice that Frequency Band 1 passes the ripple test. It has an absolute ripple value of 1.675 dB while the maximum ripple value entered for Frequency Band 1 was 2.0 dB. Thus, even though the ripple test fails because of Frequency Band 3, the ripple passes in Frequency Band 1.

Figure 1-69 Filter Pass Band with Absolute Ripple Value for Band 1 Activated

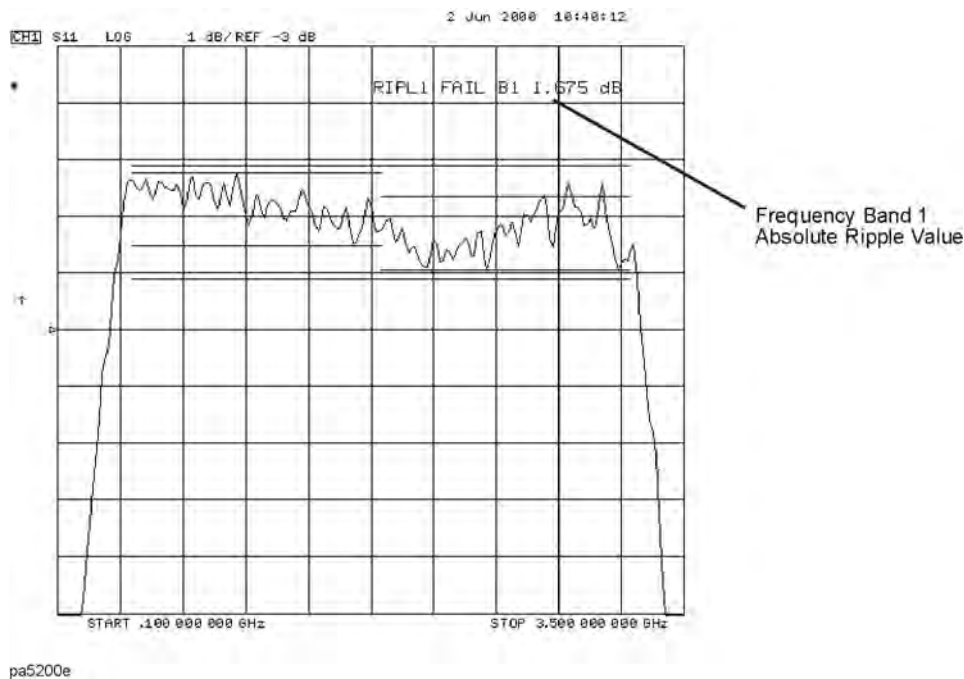

Viewing the Ripple Value in Margin Format

When **RIPL VALUE [MARGIN]** is selected, the margin by which the ripple value passed or failed is displayed. The ripple value margin is the user-defined maximum ripple minus the absolute ripple value within the frequency band. This value is displayed in dB. A positive value is the margin by which the ripple passes the ripple test in the frequency band. A negative value is the margin by which the ripple fails the ripple test in the frequency band.

Figure 1-70 shows the ripple test with margin ripple value displayed for Frequency Band 2. Notice that Frequency Band 2 passes the ripple test with a margin of 0.097 dB. The plus sign (+) indicates this band passes the ripple test by the amount displayed. A minus sign (-) would indicate that the band failed by the displayed amount.

Figure 1-70 Filter Pass Band with Margin Ripple Value for Band 2 Activated

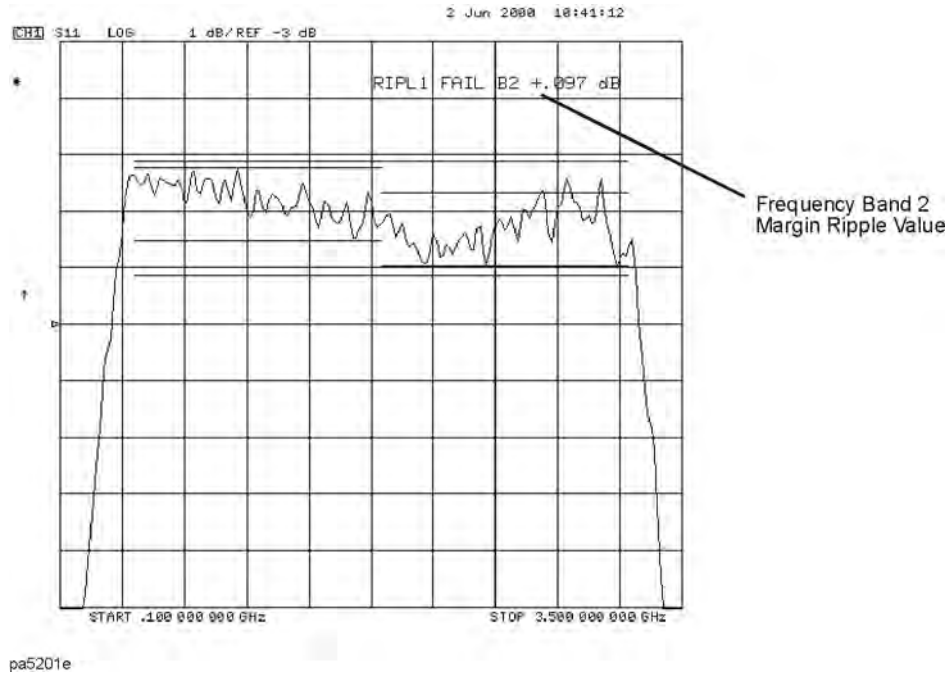

Using Bandwidth Limits to Test a Bandpass Filter

The bandwidth testing mode can be used to test the bandwidth of a bandpass filter. The bandwidth test finds the peak of a signal in the passband and locates a point on each side of the passband at an amplitude below the peak (that you specify during the test setup). The frequency between these two points is the bandwidth of the filter. This bandwidth is compared to minimum and maximum allowable bandwidths that you specify during the test setup.

This example shows you how to test the bandwidth of a bandpass filter. In this example, we will be testing the pass band of a bandpass filter where the center frequency of the filter is approximately 321 MHz. Refer to [Figure 1-71](#).

Figure 1-71 Bandpass Filter Being Bandwidth Tested

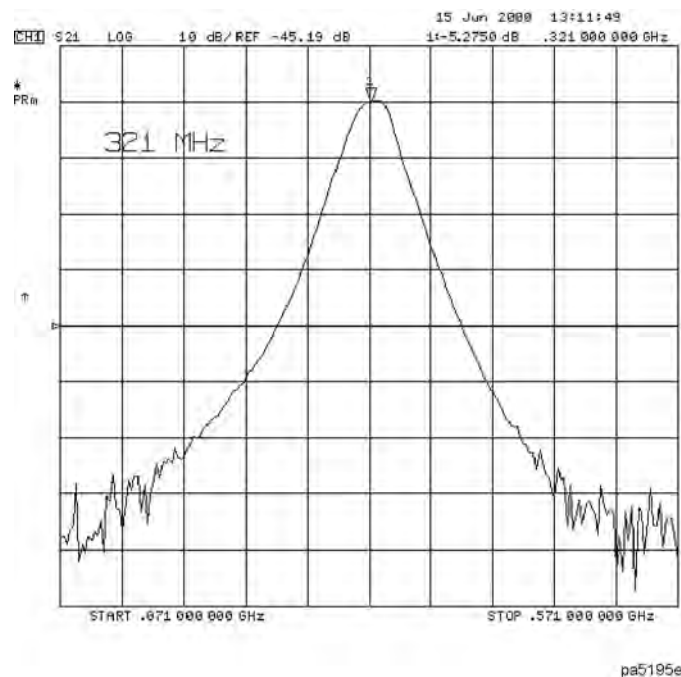

Setting Up Bandwidth Limits

When you set up the bandwidth limits to test the bandpass filter, you will first set up the analyzer to perform the bandwidth test and then you will set up bandwidth limits of the bandwidth test.

Setting Up the Analyzer to Perform the Bandwidth Test

This section sets up the analyzer so that a bandpass filter can be easily viewed on the analyzer display.

1. Connect your filter as shown in [Figure 1-72](#).

Figure 1-72 Connections for a Bandpass Filter Example Measurement

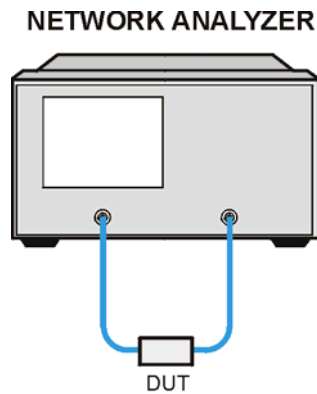

pa52e

2. Press **Preset** and choose the measurement settings. For this example, the measurement settings are as follows:
 - a. **Meas** **Trans: FWD S21 (B/R)** or on ET models: **TRANSMISSN**
 - b. **Center** **321** **(M/μ)**
 - c. **Span** **200** **(M/μ)**
 - d. **Scale Ref** **AUTO SCALE**

You may also want to select settings for the number of data points, power, averaging, and IF bandwidth.

Figure 1-73 Filter Pass Band Before Bandwidth Test

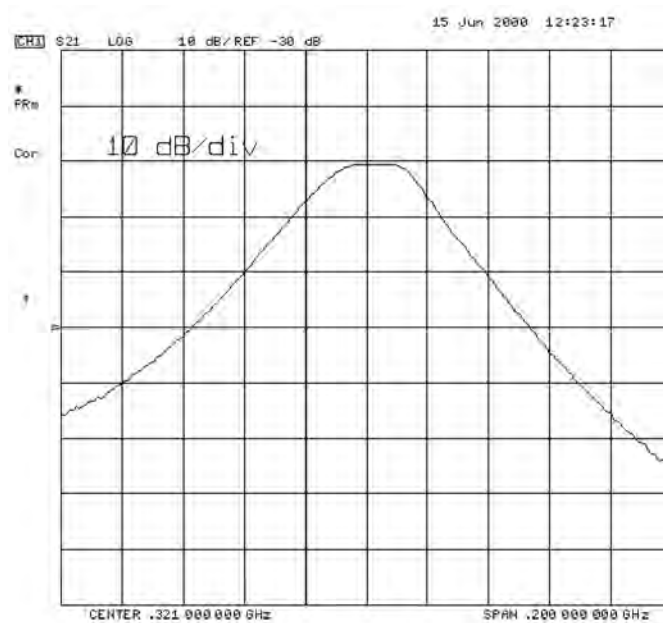

pa5191e

3. Substitute a thru for the device and perform a response calibration by pressing:

Cal **CALIBRATE MENU** **RESPONSE** **THRU**

4. Reconnect your test device.

Refer to [Figure 1-73](#).

Setting Up the Bandwidth Limits

When you set up the bandwidth limits to test the bandpass filter, you will set

- the amplitude below the peak that is used to measure the filter's bandwidth. This setting is called *N dB Points*.
 - the *Maximum Bandwidth* value. If the measured bandwidth is greater than this value, the test will fail.
 - the *Minimum Bandwidth* value. If the measured bandwidth is less than this value, the test will fail.
1. To access the bandwidth menu, press:

System **LIMIT MENU** **BANDWIDTH LIMIT**

2. To set the amplitude below the peak passband amplitude that you want to measure the bandwidth. In this case, we are setting the bandwidth that will be measured 40 dB below the peak amplitude of the bandpass filter by pressing:

N DB POINTS **40** **x1**

3. To set the minimum bandwidth for the bandwidth test, press:

MINIMUM BANDWIDTH **100** **M/μ**

4. To set the maximum bandwidth for the bandwidth test, press:

MAXIMUM BANDWIDTH **150** **M/μ**

Running a Bandwidth Test

After setting up the bandwidth limits, you are ready to run the bandwidth test and check the test results. For this example, we will:

- Start the test.
- Display the bandwidth markers.
- Review the test results.

Activating the Bandwidth Test

1. Start the bandwidth test by pressing the **BW TEST on OFF** softkey until ON is displayed.

The bandwidth test continues to run until the softkey is returned to the OFF position.

The test displays a message in the upper left corner of the graticule showing that the bandwidth test is being performed and the channel on which the test is being performed. For example, BW1: indicates that the bandwidth test is being run on channel 1. See [Figure 1-74](#).

The test also displays a message indicating whether the filter passes or fails the bandwidth test. When the filter is passing the test, the message indicates Pass. When the filter is failing the test, the failure message indicates either Wide (when the pass band is wider than the maximum bandwidth input) or Narrow (when the pass band is narrower than the minimum bandwidth input).

When the filter passes the bandwidth test, the color of the bandwidth test Pass message is green. When the filter fails the bandwidth test, the color of the bandwidth test Wide/Narrow message is red.

Figure 1-74 Filter Pass Band with Bandwidth Test Activated

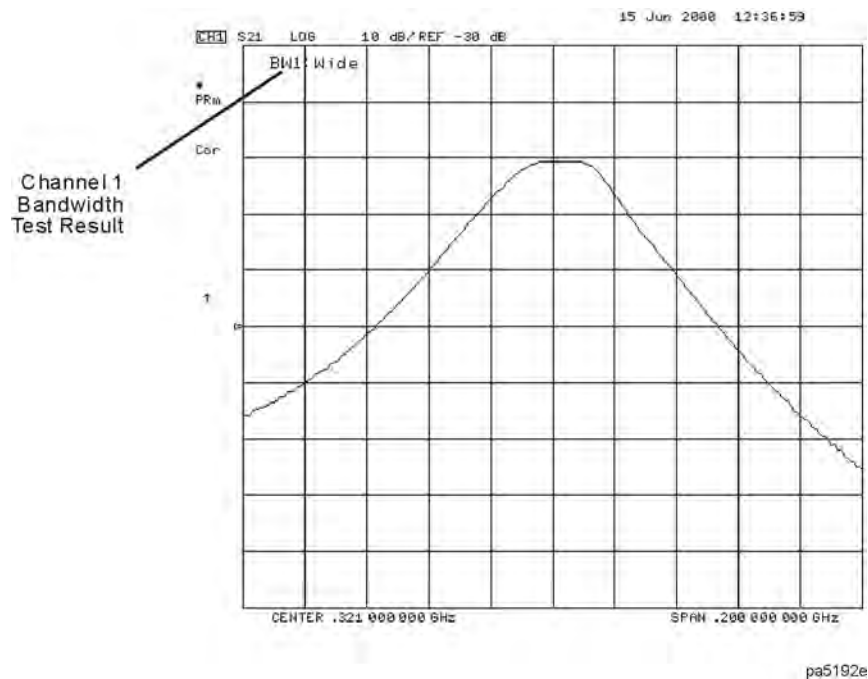

Displaying the Bandwidth Markers

1. Display the bandwidth markers by pressing the **BW MARKER on OFF** softkey until ON is displayed on the softkey.

When the bandwidth markers are displayed, a marker is placed on each side of the peak amplitude at a position equal to the N dB Points value below the peak. The markers are placed at the 40 dB points on the signal in [Figure 1-75](#). The bandwidth markers resemble the following symbol: T

Figure 1-75 Bandwidth Markers Placed 40 dB Below the Bandpass Peak

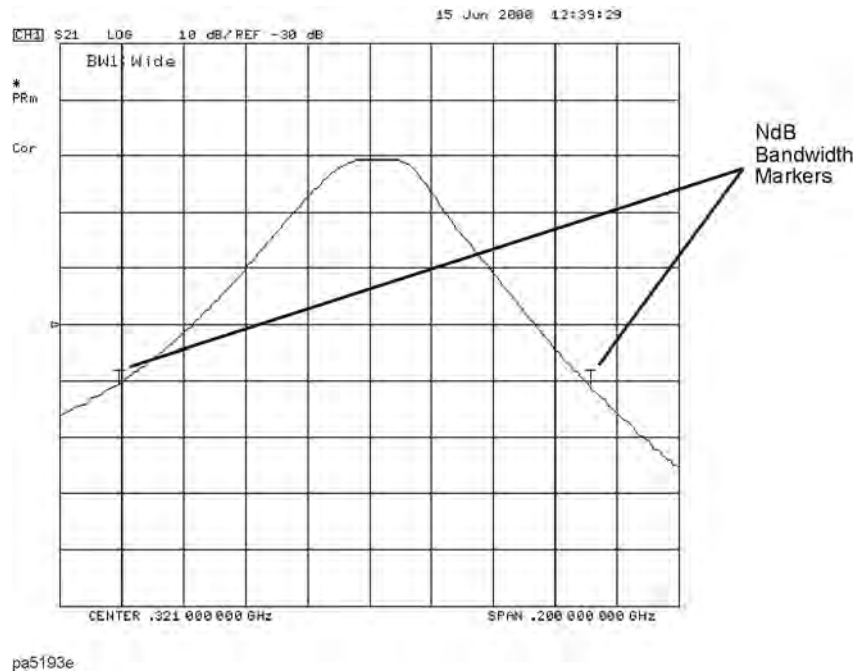

Displaying the Bandwidth Value

1. Display the bandwidth value by pressing the **BW DISPLAY on OFF** softkey until ON is displayed on the softkey.

When this softkey is set to the ON position, the measured bandwidth value is displayed in the upper left corner of the display, to the right of the bandwidth Pass/Wide/Narrow message. This value changes as the analyzer continues measuring the bandwidth. The bandwidth value is displayed in [Figure 1-76](#).

If the filter is failing the bandwidth test, the color of the bandwidth value is red, the same color as the failure (Wide) message of [Figure 1-74](#). If the filter is passing the bandwidth test, the displayed bandwidth value is green (the same color as the bandwidth test Pass message).

Figure 1-76 Filter Pass Band with Bandwidth Value Displayed

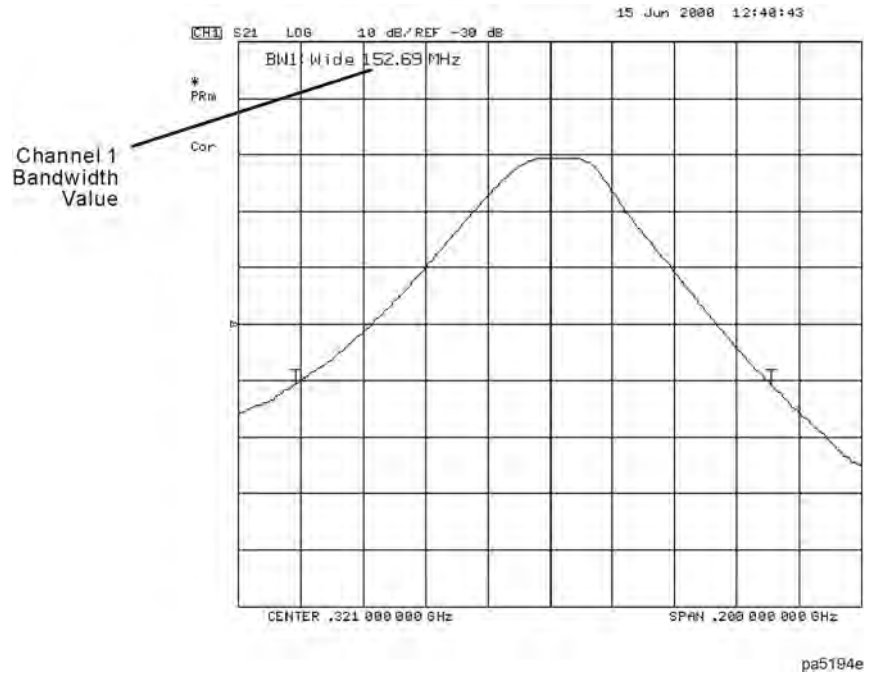

Using Test Sequencing

Test sequencing allows you to automate repetitive tasks. As you make a measurement, the analyzer memorizes the keystrokes. Later you can repeat the entire sequence by pressing a single key. Because the sequence is defined with normal measurement keystrokes, you do not need additional programming expertise. Subroutines and limited decision-making increases the flexibility of test sequences. In addition, the GPIO outputs can be controlled in a test sequence, and the GPIO inputs can be tested in a sequence for conditional branching.

The test sequence function allows you to create, title, save, and execute up to six independent sequences internally. You can also save sequences to disk and transfer them from the analyzer to another analyzer or possibly to an external computer controller (so the sequence can be sent to another analyzer).

How to Use Test Sequencing

The following procedures, which are based on an actual measurement example, show you how to do the following:

- create a sequence
- title a sequence
- edit a sequence
- clear a sequence
- change a sequence title
- name files generated by a sequence
- store a sequence
- load a sequence
- purge a sequence
- print a sequence

Creating a Sequence

1. To enter the sequence creation mode, press:

Seq **NEW SEQ/MODIFY SEQ**

As shown in [Figure 1-77](#), a list of instructions appear on the analyzer display to help you create or edit a sequence.

Figure 1-77 Test Sequencing Help Instructions

TEST SEQUENCING

MODIFY

To INSERT – Any function inserted after cursor.

To DELETE – BACK SP deletes line at cursor.

To STEP – Use ARROW keys or knob. ARROW up does the function after the cursor and moves list up. ARROW down only moves list down.

To END – Press DONE SEQ MODIFY in SEQUENCE MENU.

RUN

To START – Press DO SEQUENCE in SEQUENCE MENU.

KEYS – All front panel keys except LOCAL are locked out until sequence stops.

To STOP – Press LOCAL to stop a running sequence.

To PAUSE – Press CONTINUE SEQUENCE in SEQUENCE MENU to restart a paused sequence.

Only sequence 6 is saved when instrument is turned off.

Select a softkey to start modifying a sequence –

- To select a sequence position in which to store your sequence, press:

SEQUENCE 1 SEQ1

This choice selects sequence position #1. The default title is SEQ1 for this sequence.

Refer to ["Changing the Sequence Title" on page 1-103](#) for information on how to modify a sequence title.

- To create a test sequence, enter the parameters for the measurement that you wish to make. For this example, a SAW filter measurement is set up with the following parameters:

Save/Recall **SELECT DISK** **INTERNAL MEMORY**

Use the front panel knob to scroll until **Preset State** is highlighted on the display.

RETURN **RECALL STATE**

Meas **Trans: FWD S21 (B/R)** or **TRANSMISSION**

Format **LOG MAG**

Center **134** **M/μ**

Span **50** **M/μ**

Scale Ref **AUTOSCALE**

Making Measurements

Using Test Sequencing

The previous keystrokes will create a displayed list as shown:

```
Start of Sequence
RECALL PRST STATE
Trans: FWD S21 (B/R)
LOG MAG
CENTER
  134 M/u
SPAN
  50 M/u
SCALE/DIV
AUTO SCALE
```

4. To complete the sequence creation, press:

Seq **DONE SEQ MODIFY**

CAUTION When you create a sequence, the analyzer stores it in volatile memory where it will be lost if you switch off the instrument power (except for sequence #6 which is stored in the analyzer non-volatile memory). However, you may store sequences to a floppy disk.

Running a Sequence

To run a stored test sequence, press:

Preset and the softkey labeled with desired sequence number.

or, press:

Seq **DO SEQUENCE** and the softkey labeled with the desired sequence number

Stopping a Sequence

To stop a sequence before it has finished, press **Local**.

Editing a Sequence

Deleting Commands



1. To enter the creation/editing mode, press:





Seq **NEW SEQ/MODIFY SEQ**

2. To select the particular test sequence you wish to modify (sequence 1 in this example), press:







SEQUENCE 1 SEQ1

3. To move the cursor to the command that you wish to delete, press:



 or 

- If you wish to scroll through the sequence without executing each line as you do so, you can press the  key and scroll through the command list backwards.
 - If you use the  key to move the cursor through the list of commands, the commands are actually performed when the cursor points to them. This feature allows the sequence to be tested one command at a time.
4. To delete the selected command, press:
 (backspace key)
 5. Press  **DONE SEQ MODIFY** to exit the modify (edit) mode.

Inserting a Command

1. To enter the creation/editing mode, press:
 **NEW SEQ/MODIFY SEQ**
2. To select the particular test sequence you wish to modify (sequence 1 in this example), press:
SEQUENCE 1 SEQ1
3. To insert a command, move the cursor to the line immediately above the line where you want to insert a new command, by pressing:
 or 
 - If you use the  key to move the cursor through the list of commands, the commands are actually performed when the cursor points to them. This feature allows the sequence to be tested one command at a time.
 - If you wish to scroll through the sequence without executing each line as you do so, you can press the  key and scroll through the command list backwards.
4. To enter the new command, press the corresponding analyzer front panel keys. For example, if you want to activate the averaging function, press:
 **AVERAGING ON**
5. Press  **DONE SEQ MODIFY** to exit the modify (edit) mode.

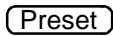
Modifying a Command

1. To enter the creation/editing mode, press:
  **NEW SEQ/MODIFY SEQ**
2. To select the particular test sequence you wish to modify, (sequence 1 in this example), press:
SEQUENCE 1 SEQ1

The following list is the commands entered in "Creating a Sequence" on page 1-98. Notice that for longer sequences, only a portion of the list can appear on the screen at one time.

Start of Sequence

Making Measurements

Using Test Sequencing

```
RECALL PRST STATE
Trans: FWD S21 (B/R)
LOG MAG
CENTER
    134 M/u
SPAN
    50 M/u
SCALE/DIV
AUTO SCALE
```

3. To change a command (for example, the span value from 50 MHz to 75 MHz), move the cursor (→) next to the command that you wish to modify, press:

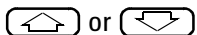

- If you use the key to move the cursor through the list of commands, the commands are actually performed when the cursor points to them. This feature allows the sequence to be tested one command at a time.
 - If you wish to scroll through the sequence without executing each line as you do so, you can press the key and scroll through the command list backwards.
4. To delete the current command (for example, span value), press:



5. To insert a new value (for example, 75 MHz), press:



6. Press **DONE SEQ MODIFY** to exit the modify (edit) mode.

Clearing a Sequence from Memory

1. To enter the menu where you can clear a sequence from memory, press:



2. To clear a sequence, press the softkey of the particular sequence.

Changing the Sequence Title

If you are storing sequences on a disk, you should replace the default titles (SEQ1, SEQ2, ...).

1. To select a sequence that you want to retitle, press:

Seq **MORE** **TITLE SEQUENCE** and select the particular sequence softkey.

The analyzer shows the available title characters. The current title is displayed in the upper-left corner of the screen.

2. You can create a new file name in two ways:

- If you have an attached DIN keyboard, you can press the f6 function key on the keyboard and type the new file name.
- If you do not have an attached DIN keyboard, press **ERASE TITLE** and turn the front panel knob to point to the characters of the new file name, pressing **SELECT LETTER** as you stop at each character.

The analyzer cannot accept a title (file name) that is longer than eight characters. Your titles must also begin with a letter, and contain only letters and numbers.

3. To complete the titling, press **DONE**.

Naming Files Generated by a Sequence

The analyzer can automatically increment the name of a file that is generated by a sequence using a loop structure. (See example "[Loop counter decision making](#)" on page 1-113.)

To access the sequence file name menu, press:

- **Save/Recall**
- **FILE UTILITIES**
- **SEQUENCE FILENAMING**

This menu presents two choices:

- **FILE NAME FILE0** supplies a name for the saved state or data file. This also brings up the Title File Menu.
- **PLOT NAME PLOTFILE** supplies a name for the plot file generated by a plot-to-disk command. This also brings up the Title File Menu.

These keys show the current file name in the 2nd line of the softkey.

When titling a file for use in a loop function, you are restricted to only 2 characters in the file name due to the 6 character length of the loop counter keyword "[LOOP]." When the file is actually written, the [LOOP] keyword is expanded to only 5 ASCII characters (digits), resulting in a 7 character file name.

After entering the 2 character file name, press:

LOOP COUNTER **DONE**

Storing a Sequence on a Disk

1. To format a disk, refer to [Chapter 4](#), “Printing, Plotting, and Saving Measurement Results.”
2. To save a sequence to the internal disk, press:

Seq **MORE** **STORE SEQ TO DISK** and select the particular sequence softkey.

The disk drive access light should turn on briefly. When it goes out, the sequence has been saved.

CAUTION The analyzer will overwrite a file on the disk that has the same title.

CAUTION Do not mistake the line switch for the disk eject button.

Loading a Sequence from Disk

For this procedure to work, the desired file must exist on the disk in the analyzer drive.

1. To view the first six sequences on the disk, press:

Seq **MORE** **LOAD SEQ FROM DISK** **READ SEQ FILE TITLS**

- If the desired sequence is not among the first six files, press:

READ SEQ FILE TITLS until the desired file name appears.

2. Press the softkey next to the title of the desired sequence. The disk access light should illuminate briefly.

NOTE If you know the title of the desired sequence, you can title the sequence (1–6) with the name, and load the sequence. This is also how you can control the sequence number of an imported titled sequence.

Purging a Sequence from Disk

1. To view the contents of the disk (six titles at a time), press:

Seq **MORE** **STORE SEQ TO DISK** **PURGE SEQUENCES**
READ SEQ FILE TITLS

- If the desired sequence is not among the first six files, press:

READ SEQ FILE TITLS until the desired file name appears.

2. Press the softkey next to the title of the desired sequence. The disk access light should illuminate briefly.

Printing a Sequence

1. Configure a compatible printer to the analyzer. (Refer to the “Options and Accessories” chapter of the reference guide.)

2. To print a sequence, press:

 **MORE** **PRINT SEQUENCE** and the softkey for the desired sequence.

NOTE If the sequence is on a disk, load the sequence (as described in a previous procedure) and then follow the printing sequence.

In-Depth Sequencing Information

Features That Operate Differently When Executed in a Sequence

The analyzer does not allow you to use the following keys in a sequence:

 and  keys

 key, and

 (backspace key)

Commands That Sequencing Completes Before the Next Sequence Command Begins

The analyzer completes all operations related to the following commands before continuing with another sequence command:

- single sweep
- number of groups
- auto scale
- marker search
- marker function
- data (→) memory
- recall or save (internal or external)
- copy list values and operating parameters
- CHAN1, CHAN2, Wait 0*

*Wait 0 is the special sequencing function **WAIT x** with a zero entered for the delay value.

Commands That Require a Clean Sweep

Many front panel commands disrupt the sweep in progress, for example, changing the channel or measurement type. When the analyzer does execute a disruptive command in a sequence, some instrument functions are inhibited until a complete sweep is taken. This applies to the following functions:

- autoscale
- data → memory

Forward Stepping in Edit Mode

In the sequence modify mode, you can step through the selected sequence list, where the analyzer executes each step using the .

Titles

A title may contain non-printable or special ASCII characters if you download it from an external controller. A non-printable character is represented on the display as π .

Sequence Size

A sequence may contain up to 2 kbytes of instructions. Typically, this is around 200 sequence command lines. To estimate a sequence's size (in kbytes), use the following guidelines.

Table 1-4 Guidelines for Determining the Size of a Sequence

Type of Command	Size in Bytes
Typical command	2
Title string character	1
Active entry command	1 per digit

Embedding the Value of the Loop Counter in a Title

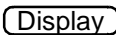
You can append a sequentially increasing or decreasing numeric value to the title of stored data by placing a  **MORE** **TITLE** **MORE** **LOOP COUNTER** command after the title string. (You must limit the title to three characters if you will use it as a disk file name. The three-character title and five-digit loop counter number reach the eight-character limit for disk file names.) This feature is useful in data logging applications.

Autostarting Sequences

You can define a sequence to run automatically when you apply power to the analyzer. To make an autostarting sequence, create a sequence in position six (SEQ6) and title it "AUTO". To stop an autostarting sequence, press . To stop an autostarting sequence from engaging at power on, you must clear it from memory or rename it.

NOTE Presetting the instrument does not run the Auto Sequence automatically.

Gosub Sequence Command

The **GOSUB SEQUENCE** softkey, located in the Sequencing menu, activates a feature that allows the sequence to branch off to another sequence, then return to the original sequence. For example, you could perform an amplifier measurement in the following manner:

1. Create sequence 1 for the specific purpose of performing the gain measurement and printing the results. This sequence will act as a sub-routine.
2. Create sequence 2 to set up a series of different input power levels for the amplifier gain measurements. In-between each power level setting, call sequence 1 as a sub-routine by pressing **GOSUB SEQUENCE SEQUENCE 1**. Now, sequence 2 will print the measurement results for each input power level applied to the amplifier.

NOTE The **GOSUB SEQUENCE** softkey branches the sequence to another sequence in a particular location (SEQ1 through SEQ6), not to a given file name.

The GPIO Mode

The instrument's parallel port can be used in two different modes. By pressing **Local** and then toggling the **PARALLEL []** softkey, you can select either the **[COPY]** mode or the **[GPIO]** mode.

The GPIO mode switches the parallel port into a “general purpose input/output” port.

In this mode, the port can be connected to test fixtures, power supplies, and other peripheral equipment that the analyzer can interact with through test sequencing.

TESTSET I/O

The TESTSET I/O interconnect on the rear panel was originally intended for use solely with the HP/Agilent 85046A/B and HP/Agilent 85047B external S-parameter test sets. Since the introduction of the 8753D, a network analyzer with an internal test set, this test set I/O port has become a general purpose control port for a variety of external devices, such as the K36 or K39 test adapters and Option 014 configurations. Refer [Table 1-5 on page 1-111](#) for the definition of each pin of the test set I/O connector.

CAUTION +22 volts is available on the TESTSET I/O connector. Be careful not to connect this to a printer port or to sensitive electronic equipment.

This connector, with the limit output, TTL OUT and TESTSET I/O outputs can also be used with part handlers to provide control interface.

The TESTSET I/O bits are set using the **TESTSET I/O FWD** and **TESTSET I/O REV** keys under the **(Seq) TTL I/O TTL OUT** keys. The values of the outputs (pins 11, 22, and 23) are described in [Table 1-5](#). The value changes with the test port, so if the external control is required for both test port directions, the settings must be made under both **TESTSET I/O FWD** and **TESTSET I/O REV**. This capability can be used to set different external conditions in a test requiring changes between the forward and reverse measurements, as might be needed in a high power test, for example.

TTL I/O Menu

This menu can be accessed by pressing **TTL I/O** in the Sequencing menu.

TTL Output for Controlling Peripherals Eight TTL compatible output lines can be used for controlling equipment connected to the parallel port. By pressing **(Seq) TTL I/O**, you will access the following softkeys that control the individual output bits. Refer to [Figure 1-78](#) for output bus pin locations.

PARALLEL OUT ALL lets you input a number (0 to 255) in base 10 and outputs it to the bus as binary.

SET BIT lets you set a single bit (0 – 7) to high on the output bus.

CLEAR BIT lets you set a single bit (0 – 7) to low on the output bus.

TTL Input Decision Making Five TTL compatible input lines can be used for decision making in test sequencing. For example, if a test fixture is connected to the parallel port and has a micro switch that needs to be activated in order to proceed with a measurement, you can construct your test sequence so that it checks the TTL state of the input line corresponding to the switch. Depending on whether the line is high or low, you can jump to another sequence. To access these decision making functions, press **(Seq) TTL I/O**. Refer to [Figure 1-78](#) for input bus pin locations.

PARALL IN BIT NUMBER lets you select the single bit (0 – 4) that the sequence will be looking for.

PARALL IN IF BIT H lets you jump to another sequence if the single input bit you selected is in a high state.

PARALL IN IF BIT L lets you jump to another sequence if the single input bit you selected is in a low state.

Pin assignments:

- pin 1 is the data strobe
- pin 16 selects the printer
- pin 17 resets the printer
- pins 18-25 are ground

Electrical specifications for TTL high:

- volts(H) ≥ 2.7 volts (V)
- current = 20 microamps (μA)

Electrical specifications for TTL low:

- volts(L) ≤ 0.4 volts (V)
- current = 0.2 milliamps (mA)

Figure 1-78 Parallel Port Input and Output Bus Pin Locations in GPIO Mode

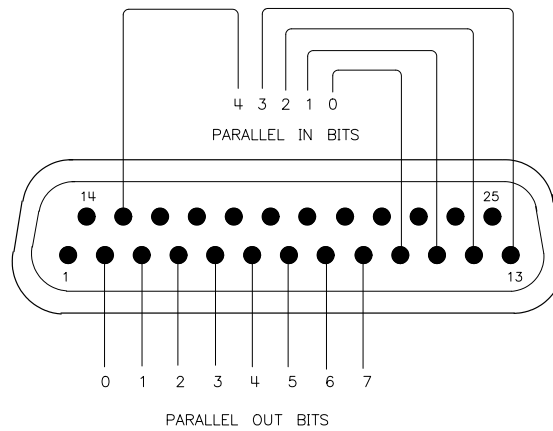

pg6129d

Test Set Interconnect Control

Figure 1-79 Test Set Interconnect Pin Designations

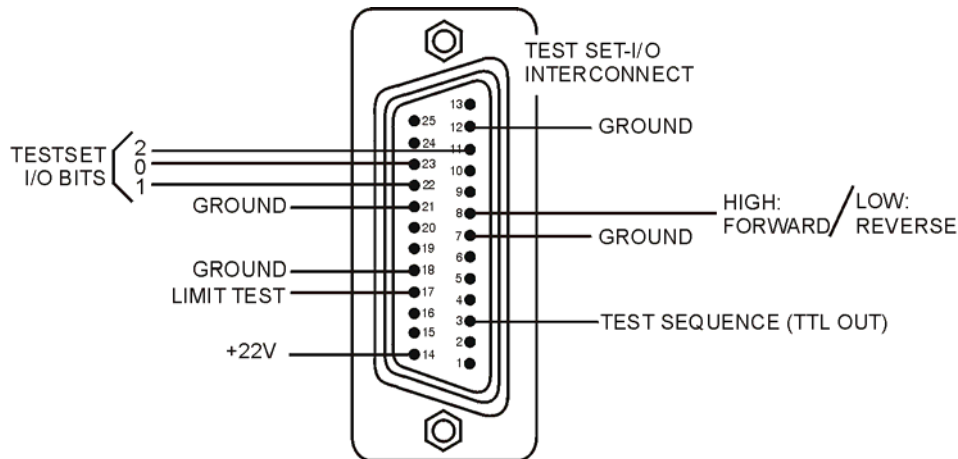

pa5176e

Control of the external switch (8762B Option T24) can be done through the test set interface on the rear panel of the analyzer.

Pin 22 (TTL 1) on the TEST SET-I/O INTERCONNECT connector is a TTL line that changes from TTL high to TTL low when changing TTL I/O FWD from 7 to 6. Refer to [Figure 1-79](#). To change from 7 to 6, press the following sequence:

- Press **TTL I/O** **TTL OUT** **TESTSET I/O FWD** **6** **x1**.

Changing the switch state back to the standard mode requires a 7 to be entered in the "TESTSET I/O FWD."

Pin 1 on the external switch must be grounded. It can be grounded to:

- the analyzer's chassis
- the front panel binder post
- the outer shell of the TEST SET-I/O INTERCONNECT connector
- a ground pin on the TEST SET-I/O INTERCONNECT connector (pin 7, 12 or 18). Refer to [Figure 1-79](#).

Pin C (common) on the external switch (8762B Option T24) must be connected to the test set interface pin 14 (+22 volt line). Refer to [Figure 1-79](#).

Pin 2 on the external switch, connects to pin 22 (TTL 1) on the test set interface.

The TTL I/O can control both of the external RF switches. Both must be cascaded in parallel together. Changing the TTL I/O FWD from 7 to 6 will change the external RF switch state. This changes the measurement capability from the network analyzer to the external test measurement device. The TTL I/O FWD when changed from 7 to 6 will reverse the process.

Table 1-5 Test Set Interconnect Pin Designation

Pin Number	Pin Description
Pin 1	No Connection (NC)
Pin 2	Sweep delay: holds off sweeps until test set has finished sweeping (85046A/B and 85047B only)
Pin 3	Same as Test Sequence (TTL OUT) output BNC connector
Pin 4	NC
Pin 5	NC
Pin 6	NC
Pin 7	Ground
Pin 8	Hi-forward/Low-reverse. Follows the test port indicator.
Pin 9	NC
Pin 10	Lstarttrig: Not used. Do not connect anything to this pin.
Pin 11	TESTSET I/O Bit 2 (most significant bit). +5 V when TESTSET I/O has values of 4, 5, 6, or 7. Otherwise, bit is TTL low.
Pin 12	Ground
Pin 13	NC
Pin 14	+22 Volts
Pin 15	NC
Pin 16	NC
Pin 17	Same as Limit Test output BNC connector
Pin 18	Ground
Pin 19	NC
Pin 20	NC
Pin 21	Ground
Pin 22	TESTSET I/O Bit 0 (least significant bit). +5 V when TESTSET I/O has values of 1, 3, 5, or 7. Otherwise, bit is TTL low.
Pin 23	TESTSET I/O Bit 1 (middle bit). +5 V when TESTSET I/O has values of 2, 3, 6, or 7. Otherwise, bit is TTL low.
Pin 24	Lremtrig: TTL low when TEST- SET I/O pins are valid. This bit can be used to latch these values.
Pin 25	NC

TTL Out Menu The **TTL OUT** softkey provides access to the TTL out menu. This menu allows you to choose between the following output parameters of the TTL output signal:

- **TTL OUT HIGH**
- **TTL OUT LOW**
- **END SWEEP HIGH PULSE**
- **END SWEEP LOW PULSE**

The TTL output signals are sent to the sequencing BNC rear panel output.

Sequencing Special Functions Menu

This menu is accessed by pressing the **SPECIAL FUNCTIONS** softkey in the Sequencing menu. This menu provides access to the decision making menu and the more special functions menu. It also contains the peripheral GPIB address and titling, wait x, pause, and marker → CW functions.

Sequence Decision Making Menu

This menu is accessed by pressing the **DECISION MAKING** softkey in the Sequencing Special Functions menu.

Decision making functions are explained in more detail in the following section. These functions check a condition and jump to a specified sequence if the condition is true. The sequence called must be in memory. A sequence call is a one-way jump. A sequence can jump to itself, or to any of the other five sequences currently in memory. Use of these features is explained under the specific softkey descriptions.

Decision Making Functions

Decision making functions jump to a softkey location, not to a specific sequence title Limit test, loop counter, and do sequence commands jump to any sequence residing in the specified sequence position (1 through 6). These commands do not jump to a specific sequence title. Whatever sequence is in the selected softkey position, will run when these commands are executed.

Having a sequence jump to itself A decision making command can jump to the sequence it is in. When this occurs, the sequence starts over and all commands in the sequence are repeated. This is used a great deal in conjunction with loop counter commands. See the loop counter description that follows.

TTL input decision making TTL input from a peripheral connected to the parallel port (in the GPIO mode) can be used in a decision making function. Refer to ["The GPIO Mode" on page 1-107](#).

Limit test decision making A sequence can jump to another sequence or start over depending on the result of a limit test. When entered into a sequence, the **IF LIMIT TEST PASS** and **IF LIMIT TEST FAIL** commands require you to enter the destination sequence.

Loop counter decision making The analyzer has a numeric register called a loop counter. The value of this register can be set by a sequence, and it can be incremented or decremented each time a sequence repeats itself. The decision making commands **IF LOOP COUNTER = 0** and **IF LOOP COUNTER <> 0** jump to another sequence if the stated condition is true. When entered into the sequence, these commands require you to enter the destination sequence. Either command can jump to another sequence, or restart the current sequence.

As explained in "[Embedding the Value of the Loop Counter in a Title](#)" on page 1-106, the loop counter value can be appended to a title. This allows customized titles for data printouts or for data files saved to disk.

Using Test Sequencing to Test a Device

Test sequencing allows you to automate repetitive tasks. As you make a measurement, the analyzer memorizes the keystrokes. Later you can repeat the entire sequence by pressing a single key.

This section contains the following example sequences:

- ["Cascading Multiple Example Sequences"](#)
- ["Loop Counter Example Sequence" on page 1-115](#)
- ["Generating Files in a Loop Counter Example Sequence" on page 1-116](#)
- ["Limit Test Example Sequence" on page 1-118](#)

Cascading Multiple Example Sequences

By cascading test sequences, you can create subprograms for a larger test sequence. You can also cascade sequences to extend the length of test sequences to greater than 200 lines.

In this example, you are shown two sequences that have been cascaded. You can do this by having the last command in sequence 1 call sequence position 2, regardless of the sequence title. Because sequences are identified by position, not title, the call operation will always go to the sequence loaded into the given position.

1. To create the example multiple sequences, press:

Seq **NEW SEQ/MODIFY SEQ** **SEQUENCE 1 SEQ1**
Center **134** **M/μ**
Span **50** **M/μ**
Seq **DO SEQUENCE** **SEQUENCE 2**
DONE SEQ MODIFY
NEW SEQ/MODIFY SEQ **SEQUENCE 2 SEQ2**
Meas **Trans: FWD S21 (B/R)** or on ET models: **TRANSMISSN**
Format **LOG MAG**
Scale Ref **AUTOSCALE**
Seq **DONE SEQ MODIFY**

The following sequences will be created:

SEQUENCE SEQ1

Start of Sequence
CENTER
134 M/u
SPAN
50 M/u
DO SEQUENCE
SEQUENCE 2

SEQUENCE SEQ2

Start of Sequence
Trans:FWD S21 (B/R)
LOG MAG
SCALE/DIV
AUTO SCALE

You can extend this process of calling the next sequence from the last line of the present sequence to 6 internal sequences, or an unlimited number of externally stored sequences.

2. To run both sequences, press:

Preset SEQUENCE 1 SEQ1

Loop Counter Example Sequence

This example shows you the basic steps necessary for constructing a looping structure within a test sequence. A typical application of this loop counter structure is for repeating a specific measurement as you step through a series of CW frequencies or dc bias levels. For an example application, see "[Fixed IF Mixer Measurements](#)" on page 2-27.

1. To create a sequence that will set the initial value of the loop counter, and call the sequence that you want to repeat, press:

Seq NEW SEQ/MODIFY SEQ SEQUENCE 1 SEQ1
SPECIAL FUNCTIONS **DECISION MAKING**
LOOP COUNTER (10) (x1)
Seq DO SEQUENCE SEQUENCE 2
DONE SEQ MODIFY

This will create a displayed list as shown:

SEQUENCE LOOP 1

Start of Sequence
LOOP COUNTER
10x1
DO SEQUENCE
SEQUENCE 2

To create a second sequence that will perform a desired measurement function, decrement the loop

Making Measurements

Using Test Sequencing to Test a Device

counter, and call itself until the loop counter value is equal to zero, press:

Seq NEW SEQ/MODIFY SEQ SEQUENCE 2 SEQ2
Meas Trans: FWD S21 (B/R) or on ET models: TRANSMISSN
Scale Ref AUTO SCALE
Marker Search SEARCH: MAX
Seq SPECIAL FUNCTIONS DECISION MAKING
DECR LOOP COUNTER IF LOOP COUNTER 0
SEQUENCE 2 SEQ2
Seq DONE SEQ MODIFY

This will create a displayed list as shown:

```
SEQUENCE LOOP 2
Start of Sequence
Trans:FWD S21 (B/R)
SCALE/DIV
AUTO SCALE
MKR Fctn
SEARCH MAX
DECR LOOP COUNTER
IF LOOP COUNTER <> 0 THEN DO
  SEQUENCE 2
```

To run the loop sequence, press:

Preset SEQUENCE 1 SEQ1

Generating Files in a Loop Counter Example Sequence

This example shows how to increment the names of files that are generated by a sequence with a loop structure.

Seq NEW SEQ/MODIFY SEQ SEQUENCE 1 SEQ 1
SPECIAL FUNCTIONS DECISION MAKING
LOOP COUNTER 7 x1
Save/Recall SELECT DISK INTERNAL DISK
RETURN DEFINE DISK-SAVE DATA ONLY ON
Local SET ADDRESSES PLOTTER PORT DISK
Seq DO SEQUENCE SEQUENCE 2
DONE SEQ MODIFY
NEW SEQ/MODIFY SEQ SEQUENCE 2 SEQ 2
Save/Recall FILE UTILITIES SEQUENCE FILE NAMING

```
FILE NAME FILE0      ERASE TITLE
D T LOOP COUNTER    DONE
PLOT NAME PLOTFILE  ERASE TITLE
P L LOOP COUNTER    DONE RETURN
(Sweep Setup) TRIGGER MENU SINGLE
(Save/Recall) SAVE STATE
(Copy) PLOT
(Seq) SPECIAL FUNCTIONS DECISION MAKING
DECR LOOP COUNTER   IF LOOP COUNTER 0
SEQUENCE 2 SEQ 2
(Seq) DONE SEQ MODIFY
```

This will create the following displayed lists:

```
Start of Sequence
LOOP COUNTER
 7 x1
INTERNAL DISK
DATA ONLY
ON
DO SEQUENCE
SEQUENCE 2
```

```
Start of Sequence
FILE NAME
DT[LOOP]
PLOT NAME
PL[LOOP]
SINGLE
SAVE FILE 0
PLOT
DECR LOOP COUNTER
IF LOOP COUNTER <> 0 THEN DO
SEQUENCE 2
```

Sequence 1 initializes the loop counter and calls sequence 2. Sequence 2 repeats until the loop counter reaches 0. For each loop, it takes a single sweep, saves the data file and plots the display.

- The data file names generated by this sequence will be:

```
DT000007.D1
```

through

```
DT000001.D1
```

- The plot file names generated by this sequence will be:

```
PL000007.FP
```

Making Measurements

Using Test Sequencing to Test a Device

through

PL00001.FP

To run the sequence, press:

Preset SEQUENCE 1 SEQ 1

Limit Test Example Sequence

This measurement example shows you how to create a sequence that will branch the sequence according to the outcome of a limit test. Refer to ["Using Limit Lines to Test a Device" on page 1-72](#), for a procedure that shows you how to create a limit test.

For this example, you must have already saved the following in register 1:

- device measurement parameters
 - a series of active (visible) limit lines
 - an active limit test
1. To create a sequence that will recall the desired instrument state, perform a limit test, and branch to another sequence position based on the outcome of that limit test, press:

Seq NEW SEQ MODIFY SEQUENCE 1 SEQ1

Save/Recall RECALL KEYS RECALLKEYS MENU RECALL REG1

Seq SPECIAL FUNCTIONS DECISION MAKING

IF LIMIT TEST PASS SEQUENCE 2 SEQ2

IF LIMIT TEST FAIL SEQUENCE 3 SEQ3

Seq DONE SEQ MODIFY

This will create a displayed list for sequence 1, as shown:

```
Start of Sequence
RECALL REG 1
IF LIMIT TEST PASS THEN DO
SEQUENCE 2
IF LIMIT TEST FAIL THEN DO
SEQUENCE 3
```

2. To create a sequence that stores the measurement data for a device that has passed the limit test, press:

Seq NEW SEQ MODIFY SEQUENCE 2 SEQ2

Save/Recall SELECT DISK INTERNAL DISK RETURN

DEFINE DISK-SAVE DATA ARRAY ON RETURN SAVE STATE

Seq DONE SEQ MODIFY

This will create a displayed list for sequence 2, as shown:

```
Start of Sequence
INTERNAL DISK
```

DATA ARRAY
ON
FILENAME
FILE 0
SAVE FILE

3. To create a sequence that prompts you to tune a device that has failed the limit test, and calls sequence 1 to retest the device, press:

Seq NEW SEQ/MODIFY SEQ SEQUENCE 3 SEQ3
Display MORE TITLE
T U N E D E V I C E DONE
Seq SPECIAL FUNCTIONS PAUSE RETURN
DO SEQUENCE SEQUENCE 1 SEQ1
Seq DONE SEQ MODIFY

This will create a displayed list for sequence 3, as shown:

Start of Sequence
TITLE
TUNE DEVICE
SEQUENCE
PAUSE
DO SEQUENCE
SEQUENCE 1

You will see the “tune device” prompt in the title area or the sequence will pause until you press the **CONTINUE SEQUENCE** key.

Making Measurements
Using Test Sequencing to Test a Device

2 Making Mixer Measurements (Option 089 Only)

Using This Chapter

This chapter contains the following:

- Information on mixer measurement capabilities.
- Information on mixer measurement considerations.
- Example procedures for making the following mixer measurements:
 - Conversion loss using the frequency offset mode
 - High dynamic range swept RF/IF conversion loss
 - Fixed IF measurements
 - Group delay measurements
 - Amplitude and phase tracking
 - Conversion compression using the frequency offset mode
 - Isolation Measurements
 - SWR/Return Loss

Mixer Measurement Capabilities

The analyzer is capable of measuring the following mixer (frequency converter) parameters:

Figure 2-1 Mixer Parameters

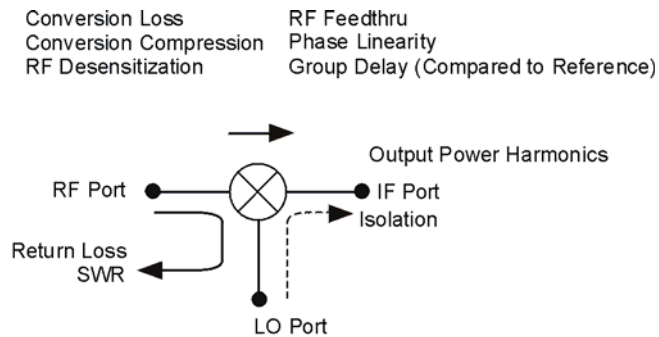

pa5160e

- Transmission characteristics include conversion loss, conversion compression, group delay, and RF feedthrough.
- Reflection characteristics include return loss, SWR and complex impedance.
- Characteristics of the signal at the output port include the output power.
- Other parameters of concern are isolation terms, including LO to RF isolation and LO to IF isolation.

NOTE This chapter uses the following 3 terms when referring to mixer signals:

LO Local Oscillator. LO is normally provided by an external source or internally generated by the frequency converter.

IF Intermediate Frequency. IF is usually the mixer's output signal.

RF Radio Frequency. RF is usually the mixer's input signal.

Measurement Considerations

In mixer transmission measurements, you have RF and LO inputs and an IF output. Also emanating from the IF port are several other mixing products of the RF and LO signals. In mixer measurements, leakage signals from one mixer port propagate and appear at the other two mixer ports. These unwanted mixing products or leakage signals can cause distortion by mixing with a harmonic of the analyzer's first down-conversion stage.

To ensure successful mixer measurements, the following measurement challenges must be taken into consideration:

- Mixer Considerations
 - ❑ ["Minimizing Source and Load Mismatches"](#)
 - ❑ ["Reducing the Effect of Spurious Responses" on page 2-5](#)
 - ❑ ["Eliminating Unwanted Mixing and Leakage Signals" on page 2-5](#)
- Analyzer Operation
 - ❑ ["How RF and IF Are Defined" on page 2-7](#)
 - ❑ ["Frequency Offset Mode Operation" on page 2-9](#)
 - ❑ ["LO Frequency Accuracy and Stability" on page 2-10](#)
 - ❑ ["Differences Between Internal and External R Channel Inputs" on page 2-10](#)
 - ❑ ["Power Meter Calibration" on page 2-12](#)

Minimizing Source and Load Mismatches

When characterizing linear devices, you can use vector accuracy enhancement to mathematically remove all systematic errors, including source and load mismatches, from your measurement. This is difficult when the device you are characterizing is a mixer where the input and output signals are at different frequencies. Therefore, source and load mismatches are not corrected for and will add to overall measurement uncertainty.

You should place attenuators at all of the test ports to reduce the measurement errors associated with the interaction between mixer port matches and system port matches. To avoid overdriving the receiver, you should give extra care to selecting the attenuator located at the mixer's IF port to avoid overdriving the receiver. For best results, you should choose the attenuator value so that the power incident on the analyzer R channel input is less than -10 dBm and greater than -35 dBm.

Figure 2-2 Conversion Loss versus Output Frequency without Attenuators at Mixer Ports

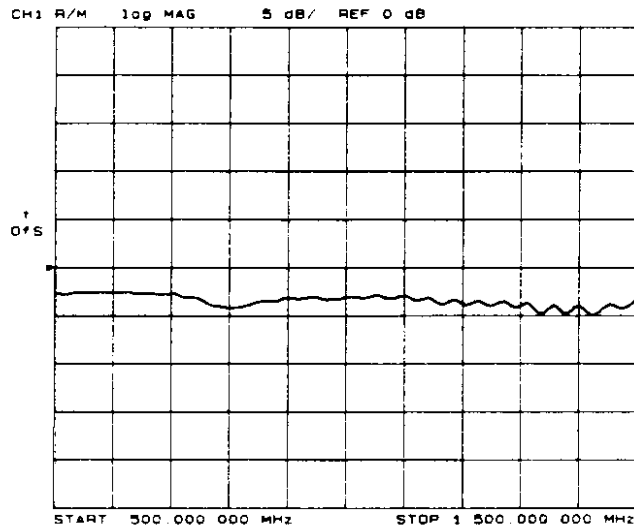

pg6162 c

Figure 2-3 Example of Conversion Loss versus Output Frequency with Attenuation at All Mixer Ports

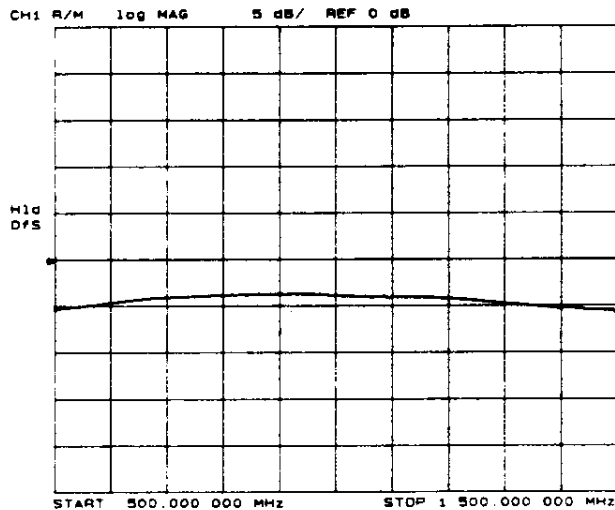

pa6161 c

Reducing the Effect of Spurious Responses

By choosing test frequencies (frequency list mode), you can reduce the effect of spurious responses on measurements by avoiding frequencies that produce IF signal path distortion.

Eliminating Unwanted Mixing and Leakage Signals

By placing filters between the mixer's IF port and the receiver's input port, you can eliminate unwanted mixing and leakage signals from entering the analyzer's receiver. Filtering is required in both fixed and

Measurement Considerations

broadband measurements. Therefore, when configuring broad-band (swept) measurements, you may need to trade some measurement bandwidth for the ability to more selectively filter signals entering the analyzer receiver.

Figure 2-4 Example of Conversion Loss versus Output Frequency without Correct IF Signal Path Filtering

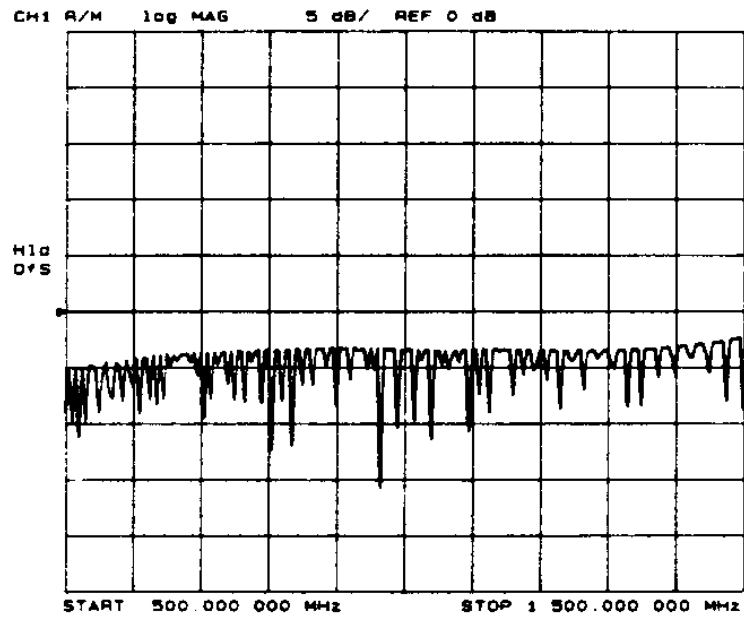

pg6160_c

Figure 2-5 Example of Conversion Loss versus Output Frequency with Correct IF Signal Path Filtering and Attenuation at All Mixer Ports

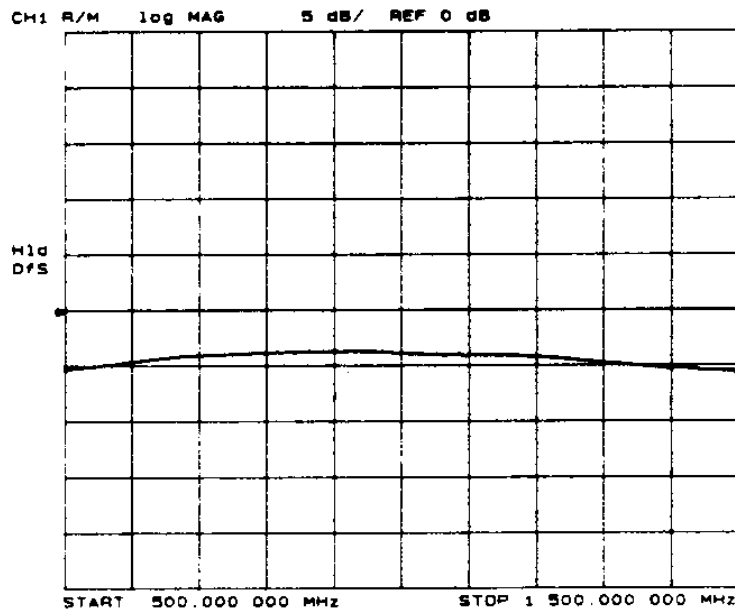

pg6161_c

How RF and IF Are Defined

When you choose between **RF < LO** and **RF > LO** in the frequency offset menus, the analyzer determines which direction the internal source must sweep in order to achieve the requested IF frequency. For example, to measure the lower sideband of a mixer, where the RF signal is below the LO (**RF < LO**), the internal source must sweep backwards. See the examples in [Figure 2-6](#).

Making Mixer Measurements (Option 089 Only)

Measurement Considerations

Figure 2-6 Examples of Up Converters and Down Converters

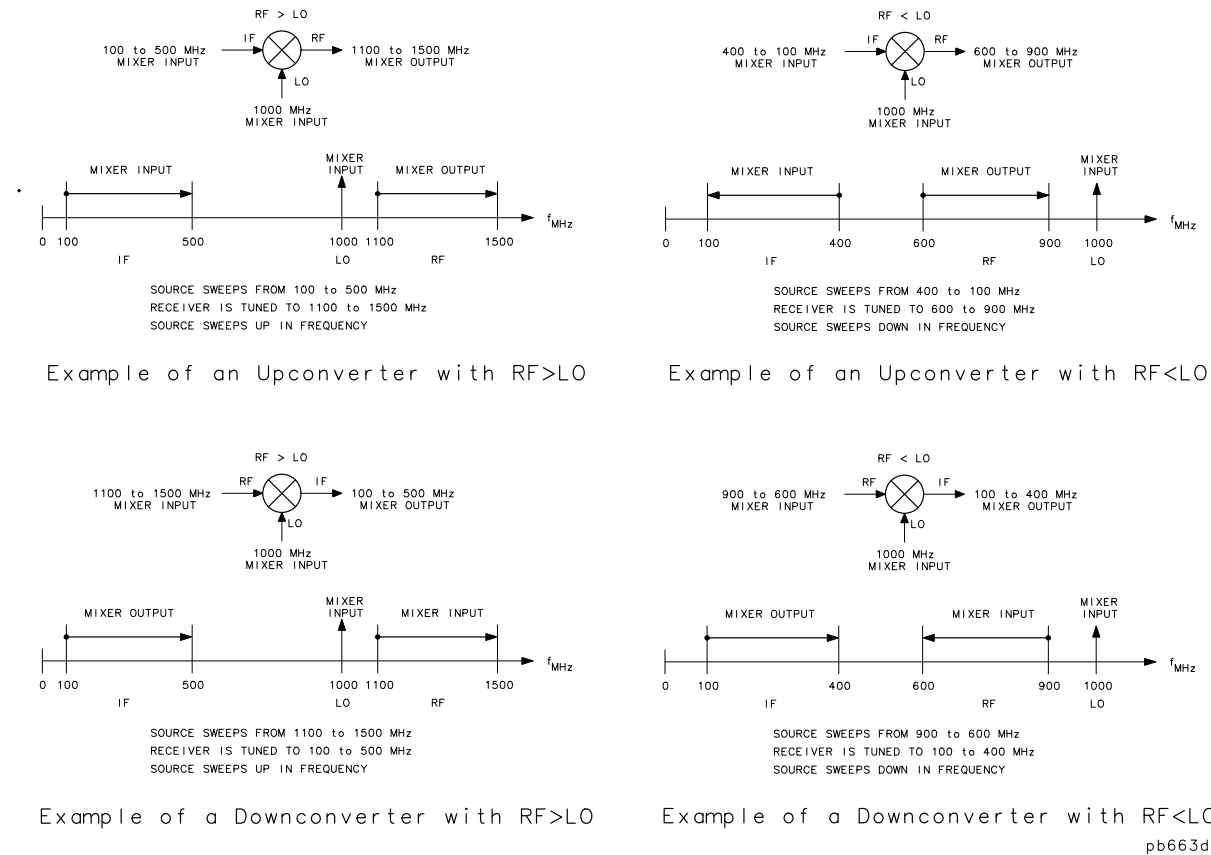

In standard mixer measurements, the input of the mixer is always connected to the analyzer's RF source, and the output of the mixer always produces the IF frequencies that are received by the analyzer's receiver.

However, the ports labeled RF and IF on most mixers are not consistently connected to the analyzer's source and receiver ports, respectively. These mixer ports are switched, depending on whether a down converter or an up converter measurement is being performed.

It is important to keep in mind that in the setup diagrams of the frequency offset mode, the analyzer's source and receiver ports are labeled according to the mixer port to which they are connected.

- In a down converter measurement where the **DOWN CONVERTER** softkey is selected, the notation on the analyzer's setup diagram indicates that the analyzer's source frequency is labeled RF, connecting to the mixer RF port, and the analyzer's receiver frequency is labeled IF, connecting to the mixer IF port.

Because the RF frequency can be greater or less than the set LO frequency in this type of measurement, you can select either **RF > LO** or **RF < LO**.

Figure 2-7 Down Converter Port Connections

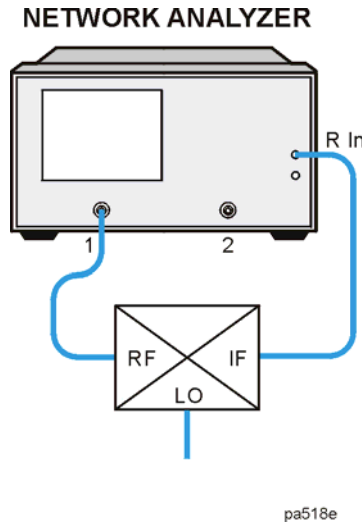

- In an up converter measurement where the **UP CONVERTER** softkey is selected, the notation on the setup diagram indicates that the analyzer's source frequency is labeled IF, connecting to the mixer IF port, and the analyzer's receiver frequency is labeled RF, connecting to the mixer RF port. Because the RF frequency can be greater or less than the set LO frequency in this type of measurement, you can select either **RF > LO** or **RF < LO**.

Figure 2-8 Up Converter Port Connections

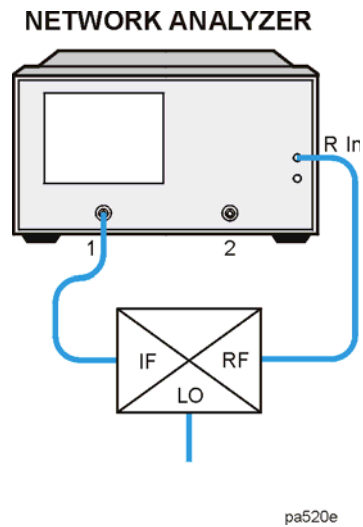

Frequency Offset Mode Operation

This mode of operation allows you to offset the analyzer's source by a fixed value, above or below the analyzer's receiver. That is, this allows you to use a device input frequency range that is different from the receiver input frequency range.

Measurement Considerations

Frequency offset measurements do not begin until all of the frequency offset mode parameters are set. These include the following:

- Start and Stop IF Frequencies
- LO frequency
- Up Converter / Down Converter
- $RF > LO$ / $RF < LO$

The LO frequency for frequency offset mode must be set to the same value as the external LO source. The offset frequency between the analyzer source and receiver will be set to this value.

For a single-sideband mixer measurement, the RF source can be offset in frequency from the input receiver frequency, allowing for a swept RF stimulus over one frequency range and measurement of the IF response over another (in this case the output IF).

When frequency offset mode operation begins, the receiver is tuned to the entered IF signal frequencies and then offsets the source frequency required to produce the IF. Therefore, since it is the analyzer receiver that controls the source, it is only necessary to set the start and stop frequencies from the receiver.

LO Frequency Accuracy and Stability

The analyzer source is phaselocked to its receiver through a reference loop. In the frequency offset mode, the mixer under test is inserted in this loop. To ensure that the analyzer phaselocks correctly, it is important that you use an LO source that has frequency accuracy better than ± 16 MHz and residual FM < 20 kHz RMS.

Differences Between Internal and External R Channel Inputs

Due to internal losses in the analyzer's test set, the power measured internally at the R channel is 16 dB lower than that of the source. To compensate for these losses, the traces associated with the R channel have been offset 16 dB higher. As a result, power measured *directly* at the R channel via the R CHANNEL IN port will appear to be 16 dB higher than its actual value. If power meter calibration is not used, this offset in power must be accounted for with a receiver calibration before performing measurements.

The following steps can be performed to observe this offset in power:

1. To set the power range to manual, press:



NOTE Since the default source output power of the 8722ES is below 0 dBm, no reduction in source output power is required for this procedure.

Setting the power range to manual prevents the internal source attenuator from switching when changing power levels. If you choose a different power range, the R channel offset compensation and R channel measurement changes by the amount of the attenuator setting.

- For this example, set the power level to -10 dBm by pressing **Power** **-10** **x1**.
- Connect the analyzer source output, port 1, directly to the R channel input as shown in [Figure 2-9](#).

CAUTION To prevent connector damage on the 8719ES, use an adapter (part number 1250-1462) as a connector saver for R CHANNEL IN.

Figure 2-9 R Channel External Connection

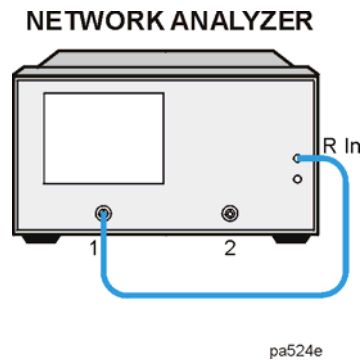

- To activate the frequency offset mode, press:

System

INSTRUMENT MODE

FREQ OFFS MENU

FREQ OFFS ON

Since the LO (offset) frequency is still set to the default value of 0 Hz, the analyzer will operate normally.

- Measure the output power in the R channel by pressing:

Meas

INPUT PORTS

R

Observe the 13 to 16 dB offset in measured power. The actual input power level to the R channel input must be 0 dBm or less, -10 dBm typical, to avoid receiver saturation effects. The minimum signal level must be greater than -35 dBm to provide sufficient signal for operation of the phaselock loop.

Measurement Considerations

6. You cannot trust R channel power settings without knowing about the offset involved. Perform a receiver calibration to remove any power offsets by pressing:

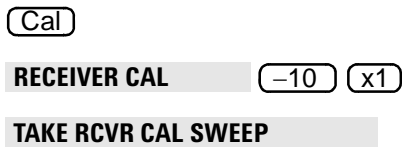

Once completed, the R channel should display the reference power (–10 dBm in this example).

Power Meter Calibration

Mixer transmission measurements are generally configured as follows:

measured output power (Watts) / set input power (Watts)

OR

measured output power (dBm) – set input power (dBm)

For this reason, the set input power must be accurately controlled in order to ensure measurement accuracy.

The amplitude variation of the analyzer is specified at ± 1 dB over any given source frequency. This may give a maximum 2 dB error for a mixer transmission test setup: ± 1 dB for the source over the IF range during measurement and ± 1 dB over the RF range during measurement.

Higher measurement accuracy may be obtained through the use of power meter calibration. You can use power meter calibration to correct for power offsets, losses, and flatness variations occurring between the analyzer source and the input to the mixer under test. Refer to the power meter documentation for its calibration procedures.

Conversion Loss Using the Frequency Offset Mode

Conversion loss is the measure of efficiency of a mixer. It is the ratio of side-band IF power to RF signal power, and is usually expressed in dB. The mixer translates the incoming signal, (RF), to a replica, (IF), displaced in frequency by the local oscillator, (LO). Frequency translation is characterized by a loss in signal amplitude and the generation of additional sidebands. For a given translation, two equal output signals are expected, a lower sideband and an upper sideband.

Figure 2-10 An Example Spectrum of RF, LO, and IF Signals Present in a Conversion Loss Measurement

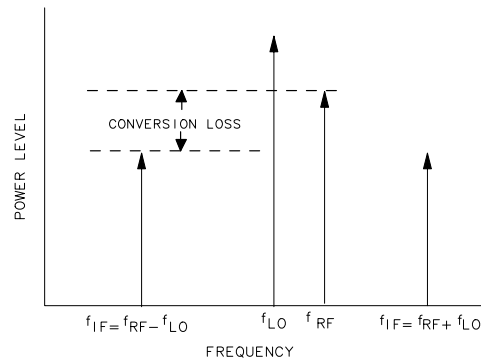

The following procedure describes the R channel swept IF frequency conversion loss measurement of a broadband component mixer with power meter calibration. For this example, we will use the following *example settings*. For your measurement, you will need to use settings specific to your measurement.

Settings Used for this Example

- LO frequency of 1 GHz (1000 MHz)
- RF start frequency of 650 MHz
- RF stop frequency of 900 MHz
- IF start frequency of 100 MHz
- IF stop frequency of 350 MHz
- $RF < LO$
- Down convertor

TIP For ease of use, the RF frequency range needs to be the same as the network analyzer's frequency range limit.

Setting Measurement Parameters for the Power Meter Calibration

1. Connect the measurement equipment as shown in Step 1 of Figure 2-11.

Figure 2-11 Connections for R Channel and Source Calibration

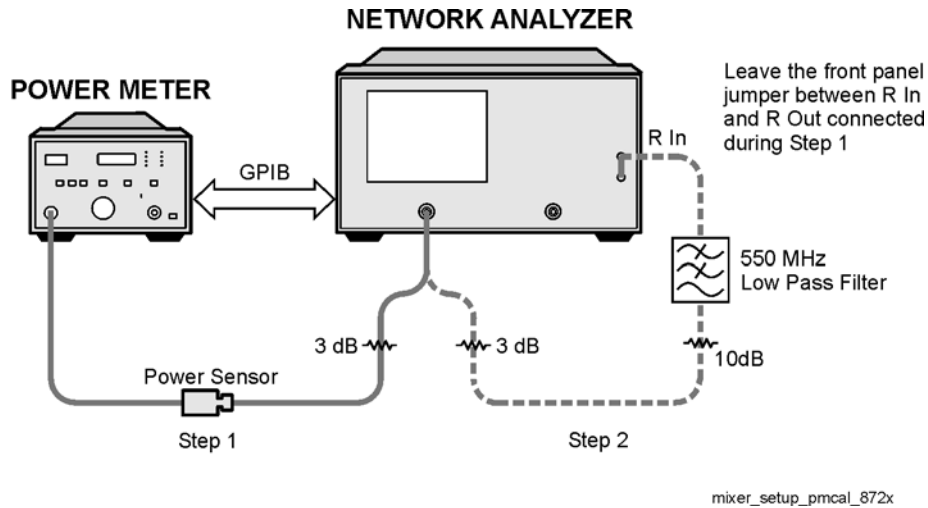

CAUTION Note that the front panel jumper between **R In** and **R Out** must remain installed during the procedure steps that use the connections in Step 1 of Figure 2-11.

2. From the front panel of the analyzer, set the desired receiver (RF) frequency and source output power by pressing:

System INSTRUMENT MODE FREQ OFFS MENU

Start 650 M/μ Stop 950 M/μ

Note that these are the example RF start and stop frequencies. Enter the RF start and stop frequencies for your measurement instead.

If the LO frequency is not set to 0 Hz, press:

LO FREQUENCY 0 x1

3. To select the measurement trace, press:

Meas INPUT PORTS R

The measurement trace is shown on the display.

4. Select the analyzer as the system controller:

Local SYSTEM CONTROLLER

Performing a Power Meter (Source) Calibration Over the RF Range

1. Calibrate and zero the power meter.
2. Set the power meter's address:

SET ADDRESSES

ADDRESS: P MTR/GPIB (where *aa* is the GPIB address of the power meter)

3. Select the appropriate power meter by pressing **POWER MTR []** until the correct model number is displayed (Agilent 436A or Agilent 438A/437).

NOTE The Agilent E4418B and E4419B (EPM) power meters have a “437emulation” mode which can be used in this procedure by following these steps.

- If you are using an Agilent EPM power sensor and your network analyzer has firmware revision 7.72 or greater:
 - a. Select the remote interface command set on the power meter by pressing the **System Inputs** key and the following softkeys: **Remote Interface, Command Set, SCPI**
 - b. Skip step 4 and continue at step 5.

The power sensor factors are automatically read by the analyzer.
- If you are using an Agilent 848X-series power sensor or your network analyzer does not have firmware revision 7.72 or greater:
 - a. Choose the 438A/437 selection on the network analyzer by pressing:

SET ADDRESSES

POWER MTR [] until it reads **POWER MTR: [438A/437]**

- b. Select the remote interface command set on the power meter by pressing the **System Inputs** key and the following softkeys: **Remote Interface, Command Set, 437B**

-
4. Press **PWRMTR CAL** **LOSS/SENSR LISTS** **CAL FACTOR** **SENSOR A** and enter the correction factors as listed on the power sensor. Press **ADD** **FREQUENCY** (where *fff* is the frequency of the calibration factor in MHz) **CAL FACTOR** (where *nnn* is the calibration factor number) **DONE** for each correction factor. When finished, press **DONE**.

Making Mixer Measurements (Option 089 Only)
Conversion Loss Using the Frequency Offset Mode

5. To perform a one sweep power meter calibration over the RF frequency range at 0 dBm (–10 dBm for 8722ES), press:

Cal **PWRMTR CAL** **ONE SWEEP**
0 **x1** (or on 8722ES: **–10** **x1**) **TAKE CAL SWEEP**

NOTE Because power meter calibration requires a longer sweep time, you may want to reduce the number of points before pressing **TAKE CAL SWEEP**. After the power meter calibration is finished, return the number of points to its original value and the analyzer will automatically interpolate this calibration.

6. Make sure the power meter calibration is on. When the power meter calibration is on, “PC” is displayed at the left edge of the display. Refer to [Figure 2-15 on page 2-19](#) for an example.
7. From the front panel of the analyzer, set the desired IF start and stop frequencies by pressing:

System **INSTRUMENT MODE** **FREQ OFFS MENU**
Start **100** **M/μ** **Stop** **350** **M/μ**

Note that these are the example IF start and stop frequencies. Enter the IF start and stop frequencies for your measurement instead.

8. To calibrate the R channel over the IF range, connect the equipment as shown in Step 2 of [Figure 2-11](#).

NOTE An error message will be displayed while the **R In** port is disconnected. Ignore this error message until **R In** port is reconnected.

9. Press **Cal** **CALIBRATE MENU** **RECEIVER CAL** **0** **x1**
TAKE RCVR CAL SWEEP.

- The low pass filter is required to limit the range of frequencies passed into the R channel input port. The filter is selected to pass the IF frequencies for the measurement but prevent the LO feedthrough and unwanted mixer products from confusing the phase-lock loop operation.
- A pad is used to isolate the filter and improve the IF port match for the mixer.

Once completed, the display should read 0 dBm (–10 dBm for 8722ES).

10. Save the power meter and receiver calibration to an instrument state by pressing **Save/Recall**
SAVE STATE.

Setting the Analyzer to Make an R Channel Measurement

1. Connect the equipment as shown in Figure 2-12.

Figure 2-12 R-Channel Mixer Measurement Equipment Setup

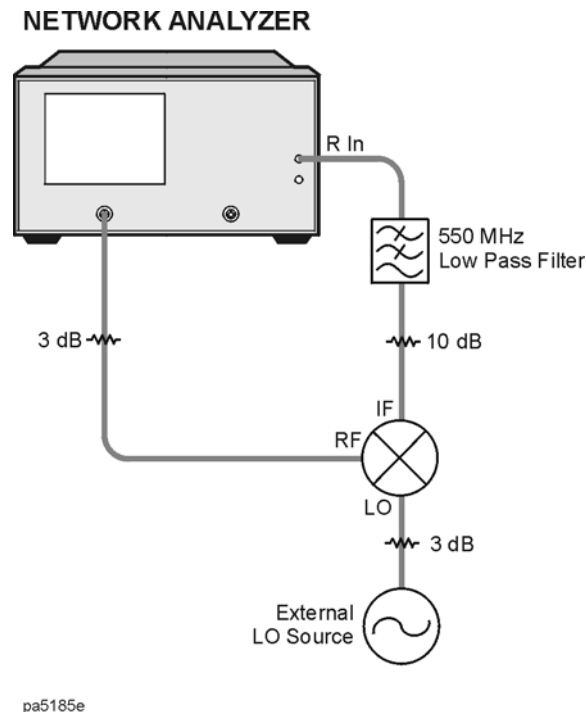

NOTE An error message will be displayed while the **R In** port is disconnected. Ignore this error message until step 3 is complete.

The analyzer is now displaying the conversion loss of the mixer calibrated with power meter accuracy.

2. While the analyzer is still set to the IF frequency range, set the frequency offset mode LO frequency from the analyzer by pressing:

System **INSTRUMENT MODE** **FREQ OFFS MENU**
LO FREQUENCY **1000** **M/Hz**

Note that this is the example LO frequency. Enter the LO frequency for your measurement instead.

The LO menu is used to set only the LO CW frequency. All other settings apply when using the HP/Agilent 8625A external source.

3. To select the converter type and a high-side LO measurement configuration, press:

RETURN **DOWN CONVERTER** **RF < LO**

Note that these are the example settings. Enter the settings for your measurement instead.

4. Turn on frequency offset operation by pressing **FREQS OFFS ON**.

Notice in this high-side LO, down conversion configuration, the analyzer's source is actually sweeping

Making Mixer Measurements (Option 089 Only)
Conversion Loss Using the Frequency Offset Mode

backwards, as shown in [Figure 2-13](#).

The measurement setup diagram is shown in [Figure 2-14](#). Note the RF frequency values are shown in this illustration.

Figure 2-13 Diagram of Measurement Frequencies

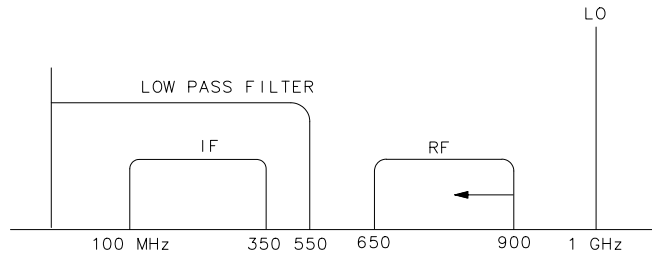

pg6155d

Figure 2-14 Measurement Setup from Display

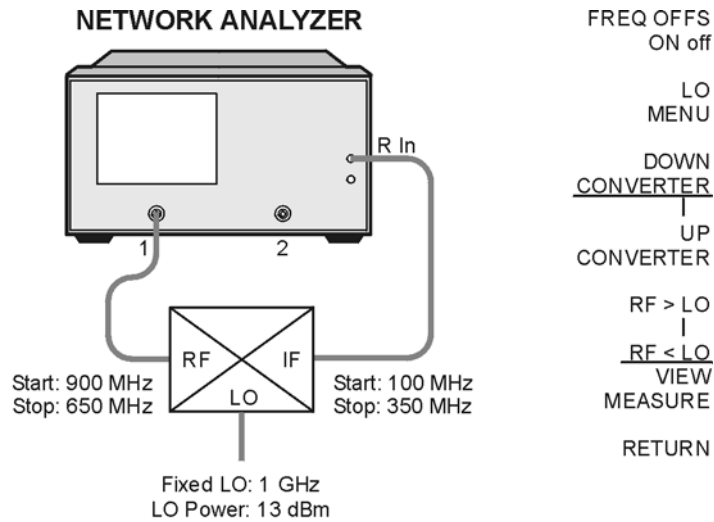

pa532e

5. To view the conversion loss in the best vertical resolution, press **Scale Ref** **AUTOSCALE**.

Figure 2-15 Conversion Loss Example Measurement

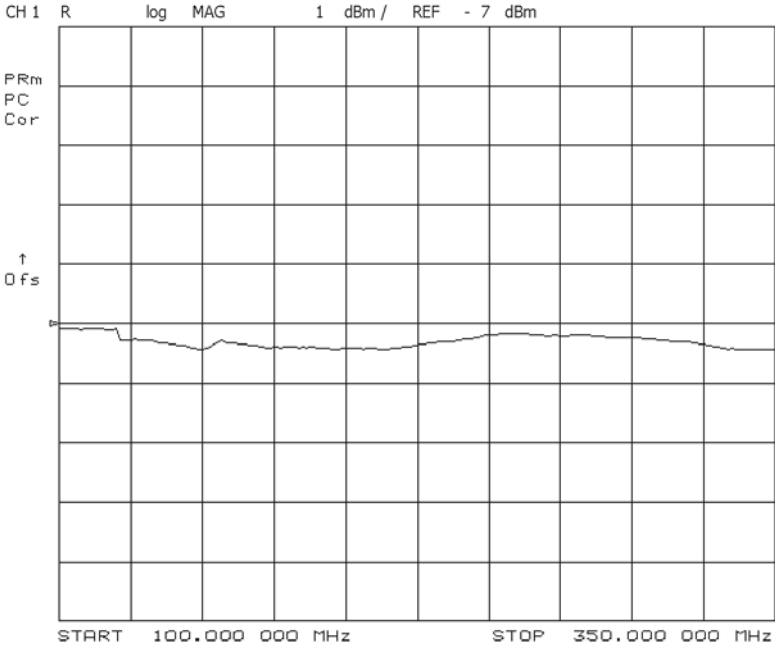

pa5190e

In this measurement, you set the input power and measured the output power. Figure 2-15 shows the absolute loss through the mixer versus mixer output frequency. If the mixer under test contained built-in amplification, then the measurement results would have shown conversion gain.

High Dynamic Range Swept RF/IF Conversion Loss

The frequency offset mode enables the testing of high dynamic range frequency converters (mixers), by tuning the analyzer's high dynamic range receiver above or below its source, by a fixed offset. This capability allows the complete measurement of both pass and reject band mixer characteristics.

The analyzer has a 35 dB dynamic range limitation on measurements made directly with its R (phaselock) channel. For this reason, the measurement of high dynamic range mixing devices (such as mixers with built in amplification and filtering) with greater than 35 dB dynamic range must be made on either the analyzer's A or B channel, with a reference mixer providing input to the analyzer's R channel for phaselock.

This example describes the swept IF conversion loss measurement of a mixer and filter. The output filtering demonstrates the analyzer's ability to make high dynamic range measurements.

Set Measurement Parameters for the IF Range

Set the following analyzer parameters:

ⓅPreset
ⓅStart Ⓟ100 ⓅM/μ ⓅStop Ⓟ1 ⓅG/n
ⓅPower Ⓟ-5 **PWR RANGE MAN** Ⓟx1
ⓅSweep Setup **NUMBER of POINTS** Ⓟ10 Ⓟx1

NOTE No reduction in source output power is required for the 8722ES.

Perform a Power Meter Calibration Over the IF Range

1. Calibrate and zero the power meter.
2. Connect the measurement equipment as shown in [Figure 2-16](#).

CAUTION To prevent connector damage, use an adapter (part number 1250-1462) as a connector saver for R CHANNEL IN.

Figure 2-16 Connections for Power Meter Calibration

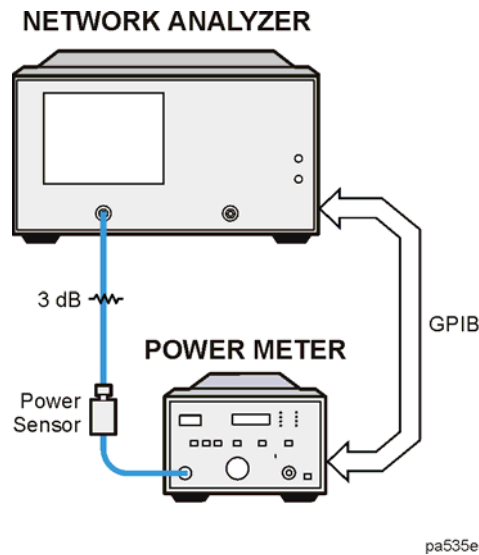

3. Select the analyzer as the system controller:

Local

SYSTEM CONTROLLER

4. Set the power meter's address:

SET ADDRESSES

ADDRESS: P MTR/GPIB **aa** (where *aa* is the power meter GPIB address) **x1**

5. Select the appropriate power meter by pressing **POWER MTR []** until the correct model number is displayed (436A or 438A/437).

NOTE The E4418B and E4419B power meters have a "437 emulation" mode. This allows these power meters, with an 848X-series power sensor, to be used with the network analyzer. In this step, when selecting a power meter, choose the 438A/437 selection.

6. Press **Cal** **PWRMTR CAL** **LOSS/SENSR LISTS** **CAL FACTOR** **SENSOR A** and enter the correction factors as listed on the power sensor. Press **ADD** **FREQUENCY** **fff** (where *fff* is the frequency in MHz) **M/μ** **CAL FACTOR** **nnn** (where *nnn* is the calibration factor number) **x1** **DONE** for each correction factor. When finished, press **DONE** **RETURN**.

7. Perform a one sweep power meter calibration over the IF frequency range at -5 dBm (-10 dBm, 8722ES):

ONE SWEEP

-5 **x1** (**-10**) **x1**, 8722ES)

TAKE CAL SWEEP

NOTE Because power meter calibration requires a longer sweep time, you may want to reduce the

number of points before pressing **TAKE CAL SWEEP**. After the power meter calibration is finished, return the number of points to its original value and the analyzer will automatically interpolate this calibration.

Perform a Receiver Calibration Over the IF Range

1. Connect the measurement equipment as shown in [Figure 2-17](#).

Figure 2-17 Connections for Receiver Calibration

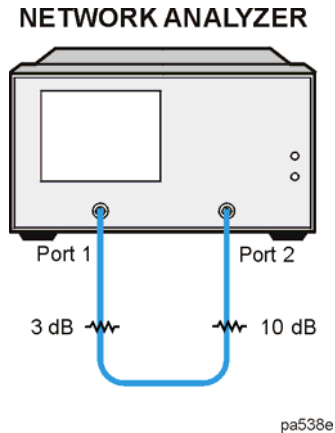

2. To calibrate the B-channel over the IF range, press:

Meas **INPUT PORTS** **B**
Cal **CALIBRATE MENU** **RECEIVER CAL** **-5** **x1** **-10** **x1**, 8722ES)
TAKE RCVR CAL SWEEP

Once completed, the analyzer should display -5 dBm (-10 dBm, 8722ES).

Set the Analyzer to the RF Frequency Range

You can find the RF frequency range by using a simple calculation or using the mixer measurement diagram on the analyzer display.

Using the Calculation

Add the LO frequency to the IF frequency start and stop values. If using an LO frequency of 1500 MHz, the RF start frequency would be 1.6 GHz (1500 + 100 MHz) and the stop frequency would be 2.5 GHz (1500 + 1000 MHz).

Using the Mixer Measurement Diagram

While the analyzer is still set to the IF frequency range, press:

System INSTRUMENT MODE FREQ OFFS MENU
 LO MENU FREQUENCY: CW 1500 M/μ
 RETURN RETURN DOWN CONVERTER RF > LO

Note the RF frequency values on the diagram.

Press **Start** 1.6 G/n **Stop** 2.5 G/n.

Perform a Power Meter Calibration Over the RF Range

1. Connect the equipment as shown in [Figure 2-18](#).

Figure 2-18 Connections for Power Meter Calibration

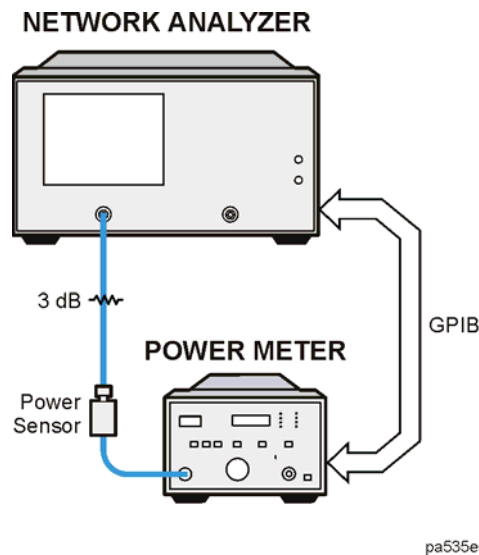

2. Use the previous power meter settings.
3. Perform a one sweep power meter calibration over the RF frequency range at -5 dBm (-10 dBm, 8722ES):

Cal PWRMTR CAL
 ONE SWEEP
-5 **x1** **-10** **x1**, 8722ES
 TAKE CAL SWEEP

Perform the High Dynamic Range Measurement

1. Return the analyzer to the IF frequency range. Press **Start** **100** **M/μ** **Stop** **1** **G/n**.
2. Make the connections shown in [Figure 2-19](#)
3. Set the LO source to the desired CW frequency of 1500 MHz and power level to 13 dBm.

Figure 2-19 Connections for a High Dynamic Range Swept IF Conversion Loss Measurement

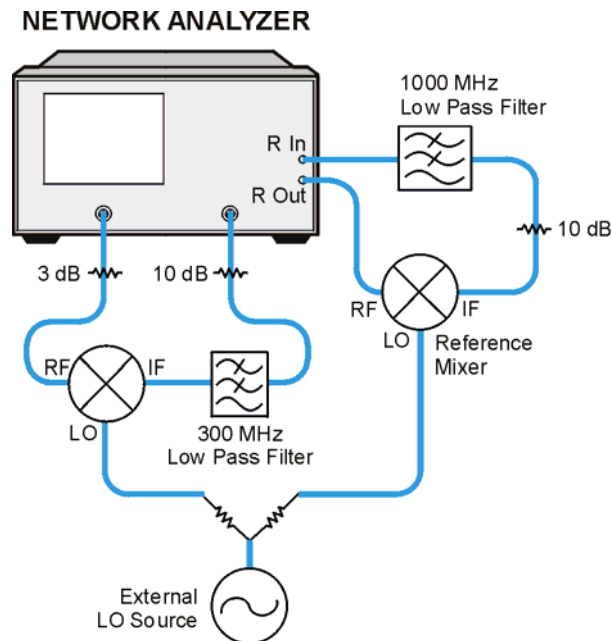

pa541e

- Set the analyzer's LO frequency to match the frequency of the LO source by pressing:

System **INSTRUMENT MODE** **FREQ OFFS MENU**
LO FREQUENCY **1500** **M/Hz**

- To select the converter type and low-side LO measurement configuration, press:

RETURN **DOWN CONVERTER** **RF > LO** **FREQ OFFS ON**

In this low-side LO, down converter measurement, the analyzer's source frequency range will be offset higher than the receiver frequency range. The source frequency range can be determined from the following equation:

$$\text{receiver frequency range (100 – 1000 MHz) + LO frequency (1500 MHz) = 1.6 – 2.5 GHz}$$

- To view the conversion loss in the best vertical resolution, press:

VIEW MEASURE **Scale Ref** **AUTOSCALE**

Figure 2-20 shows the conversion loss of this low-side LO mixer with output filtering. Notice that the dynamic range from the pass band to the noise floor is well above the dynamic range limit of the R Channel. If the mixer under test also contained amplification, then this dynamic range would have been even greater due to the conversion gain of the mixer.

Figure 2-20 Example of Swept IF Conversion Loss Measurement

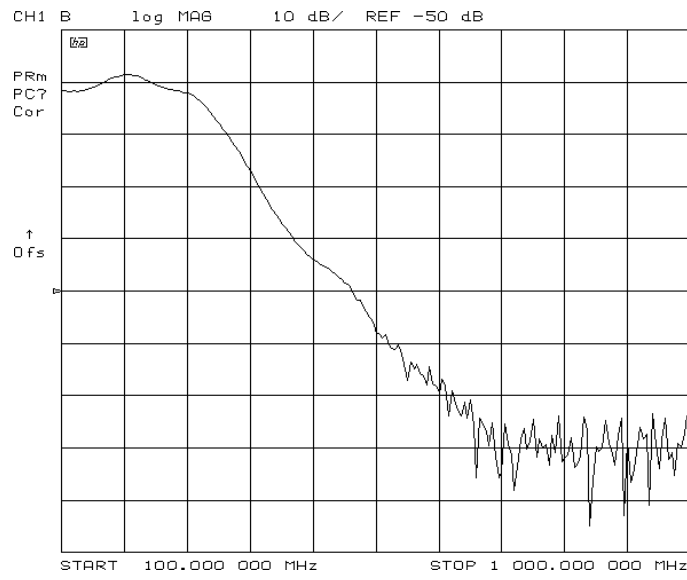

Fixed IF Mixer Measurements

A fixed IF can be produced by using both a swept RF and LO that are offset by a certain frequency. With proper filtering, only this offset frequency will be present at the IF port of the mixer.

This measurement requires two external RF sources as stimuli. [Figure 2-22](#) shows the hardware configuration for the fixed IF conversion loss measurement. This example measurement procedure uses the analyzer's test sequence function for automatically controlling the two external synthesizers (with SCPI commands), and making a conversion loss measurement in tuned receiver mode. The test sequence function is an instrument automation feature internal to the analyzer. For more information on the test sequence function, refer to "[Using Test Sequencing to Test a Device](#)" on page 1-114.

Tuned Receiver Mode

The analyzer's tuned receiver mode allows you to tune its receiver to an arbitrary frequency and measure signal power. This is only possible if the signal you wish to analyze is at an exact known frequency. Therefore, the RF and LO sources must be synthesized and synchronized with the analyzer's time base.

Since the analyzer is not phaselocking in this configuration, you can use it to measure conversion loss of a microwave mixer with an RF frequency range output.

Tuned receiver mode also increases dynamic range. Broadband techniques like diode detection have a high noise floor, while narrow band techniques like tuned receivers are much less susceptible to noise.

Sequence 1 Setup

The following sequence initializes and calibrates the network analyzer. It then initializes the two external sources prior to measurement. This sequence includes:

- putting the network analyzer into tuned receiver mode
 - setting up a frequency list sweep of 26 points
 - performing a response calibration
 - prompting the user to connect a mixer to the test set up
 - initializing a loop counter value to 26
 - addressing and configuring the two sources
 - calling the next measurement sequence
1. Make the following connections as shown in [Figure 2-21](#). Set the GPIB address of the external RF source to 19 and the external LO source to 21.
 2. Confirm that the external sources are configured to receive commands in the SCPI programming language and that their output power is switched on.

NOTE You may have to consult the user's guide of the external source being used to determine how to set the source to receive SCPI commands.

3. Be sure to connect the 10 MHz reference signals of the external sources to the EXT REF connector on

Fixed IF Mixer Measurements

the rear panel of the analyzer (a BNC tee must be used).

NOTE If the 10 MHz reference signals of the external sources are connected together, then it will only be necessary to connect one reference signal from one of the sources to the EXT REF connector of the analyzer.

Figure 2-21 Connections for a Response Calibration

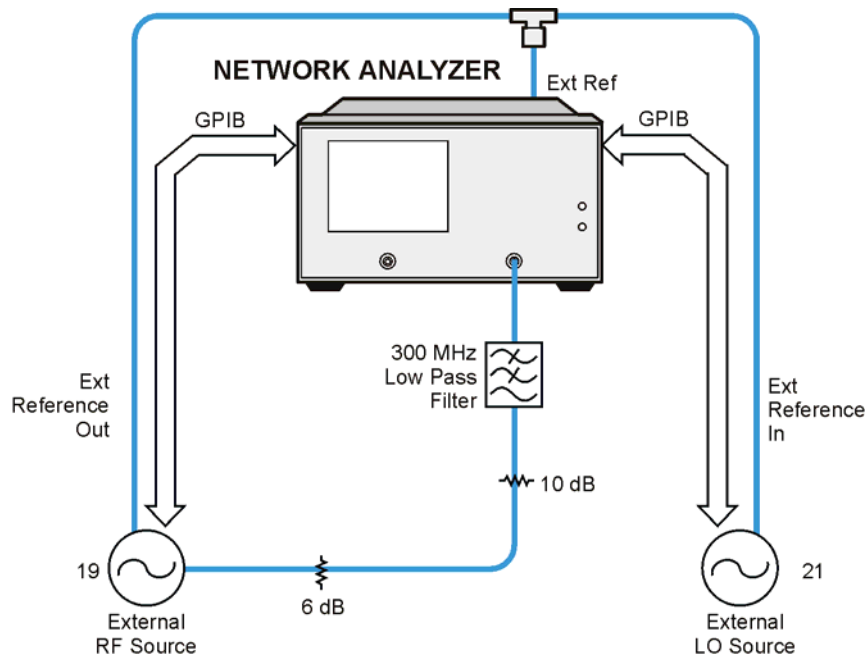

pa544e

NOTE To enter the following sequence commands that require titling, an external keyboard may be used for convenience.

4. Press the following keys on the analyzer to create sequence 1:

[Seq] **NEW SEQ./MODIFY SEQ.** **SEQUENCE 1 SEQ1**

Presetting the Instrument

[Save/Recall] **SELECT DISK** **INTERNAL MEMORY**

RETURN (Select the preset state.) **RECALL STATE**

Putting the Analyzer into Tuned Receiver Mode

Local SYSTEM CONTROLLER
System INSTRUMENT MODE TUNED RECEIVER

Setting Up a Frequency List Sweep of 26 Points

Sweep Setup SWEEP TYPE MENU EDIT LIST ADD
START 100 M/ μ
STOP 100 M/ μ
NUMBER OF POINTS 26 x1 DONE DONE
LIST FREQ

Performing a Response Calibration

Meas INPUT PORTS B
Display MORE TITLE ERASE TITLE
Input as title: POW:LEV 6DBM
DONE
Seq SPECIAL FUNCTIONS PERIPHERAL GPIB ADDR 19 x1
TITLE TO PERIPHERAL
Display MORE TITLE ERASE TITLE
Input as title: FREQ:MODE CW;CW 100MHZ
DONE
Seq SPECIAL FUNCTIONS PERIPHERAL GPIB ADDR 19 x1
TITLE TO PERIPHERAL
Cal CALIBRATE MENU RESPONSE
THRU

Prompting the User to Connect a Mixer to the Test Setup

Display MORE TITLE ERASE TITLE
Input as title: CONNECT MIXER
DONE
Seq SPECIAL FUNCTIONS
PAUSE

Fixed IF Mixer Measurements

Initializing a Loop Counter Value to 26

Seq SPECIAL FUNCTIONS DECISION MAKING

LOOP COUNTER 26 x1

Scale Ref 2 x1

REFERENCE POSITION 0 x1

REFERENCE VALUE -20 x1

Sweep Setup TRIGGER MENU MANUAL TRG ON POINT

Addressing and Configuring the Two Sources

Display MORE TITLE ERASE TITLE

Input as title: `FREQ:MODE CW;CW 500MHZ;;FREQ:CW:STEP 100MHZ`

DONE

Seq SPECIAL FUNCTIONS PERIPHERAL GPIB ADDR 19 x1

TITLE TO PERIPHERAL

Display MORE TITLE ERASE TITLE

Input as title: `POW:LEV 13DBM`

DONE

Seq SPECIAL FUNCTIONS PERIPHERAL GPIB ADDR 21 x1

TITLE TO PERIPHERAL

Display MORE TITLE ERASE TITLE

Input as title: `FREQ:MODE CW;CW 600MHZ;;FREQ:CW:STEP 100MHZ`

DONE

Seq SPECIAL FUNCTIONS PERIPHERAL GPIB ADDR 21 x1

TITLE TO PERIPHERAL

Calling the Next Measurement Sequence

Seq DO SEQUENCE SEQUENCE 2 SEQ2

Seq DONE SEQ MODIFY

Press **Seq** NEW SEQ./MODIFY SEQ SEQUENCE 1 SEQ 1 and the analyzer will display the following sequence commands:

```
SEQUENCE SEQ1
  Start of Sequence
RECALL PRST STATE
SYSTEM CONTROLLER
```

```
TUNED RECEIVER
EDIT LIST
ADD
CW FREQ
100M/u
NUMBER OF POINTS
26x1
DONE
DONE
LIST FREQ
B
TITLE
POW:LEV 6DBM
PERIPHERAL HPIB ADDR
19x1
TITLE TO PERIPHERAL
TITLE
FREQ:MODE CW;CW 100MHZ
TITLE TO PERIPHERAL
CALIBRATE: RESPONSE
CAL STANDARD
DONE CAL CLASS
TITLE
CONNECT MIXER
PAUSE
LOOP COUNTER
26x1
SCALE/DIV
2 x1
REFERENCE POSITION
0 x1
REFERENCE VALUE
-20x1
MANUAL TRG ON POINT
TITLE
FREQ:MODE CW;CW 500MHZ;:FREQ:CW:STEP 100MHZ
TITLE TO PERIPHERAL
TITLE
POW:LEV 13DBM
PERIPHERAL HPIB ADDR
21x1
TITLE TO PERIPHERAL
TITLE
FREQ:MODE CW;CW 600MHZ;:FREQ:CW:STEP 100MHZ
TITLE TO PERIPHERAL
DO SEQUENCE
SEQUENCE 2
```

Fixed IF Mixer Measurements

Sequence 2 Setup

The following sequence makes a series of measurements until all 26 CW measurements are made and the loop counter value is equal to zero. This sequence includes:

- taking data
- incrementing the source frequencies
- decrementing the loop counter
- labeling the screen

1. Press the following keys on the analyzer to create sequence 2:

NOTE To enter the following sequence commands that require titling, an external keyboard may be used for convenience.

Seq DONE SEQ MODIFY

Seq NEW SEQ/MODIFY SEQ SEQUENCE 2 SEQ2

Taking Data

Seq SPECIAL FUNCTIONS WAIT x (.1) (x1)

Sweep Setup TRIGGER MENU MANUAL TRG ON POINT

Incrementing the Source Frequencies

Display MORE TITLE ERASE TITLE

Input as title: FREQ: CW UP

DONE

Seq SPECIAL FUNCTIONS PERIPHERAL GPIB ADDR (19) (x1)

TITLE TO PERIPHERAL

PERIPHERAL GPIB ADDR (21) (x1) **TITLE TO PERIPHERAL**

Decrementing the Loop Counter

DECISION MAKING **DECR LOOP COUNTER** **IF LOOP COUNTER<>0**
SEQUENCE 2 SEQ2

Labeling the Screen

Display MORE TITLE ERASE TITLE

Input as title: MEASUREMENT COMPLETED

DONE

Seq DONE SEQ MODIFY

Press **[Seq]** **NEW SEQ/MODIFY SEQ** **SEQUENCE 2 SEQ2** and the analyzer will display the following sequence commands:

```

SEQUENCE SEQ2
Start of Sequence
WAIT x
1 x1
MANUAL TRG ON POINT
TITLE
FREQ: CW UP
PERIPHERAL HPIB ADDR
19x1
TITLE TO PERIPHERAL
PERIPHERAL HPIB ADDR
21x1
TITLE TO PERIPHERAL
DECR LOOP COUNTER
IF LOOP COUNTER <>0 THEN DO
SEQUENCE 2
TITLE
MEASUREMENT COMPLETED
    
```

2. Press the following keys to run the sequences:

[Seq] **DONE SEQ MODIFY** **DO SEQUENCE** **SEQUENCE 2 SEQ2**

When the prompt **CONNECT MIXER** appears, connect the equipment as shown in [Figure 2-22](#).

Figure 2-22 Connections for a Conversion Loss Using Tuned Receiver Mode

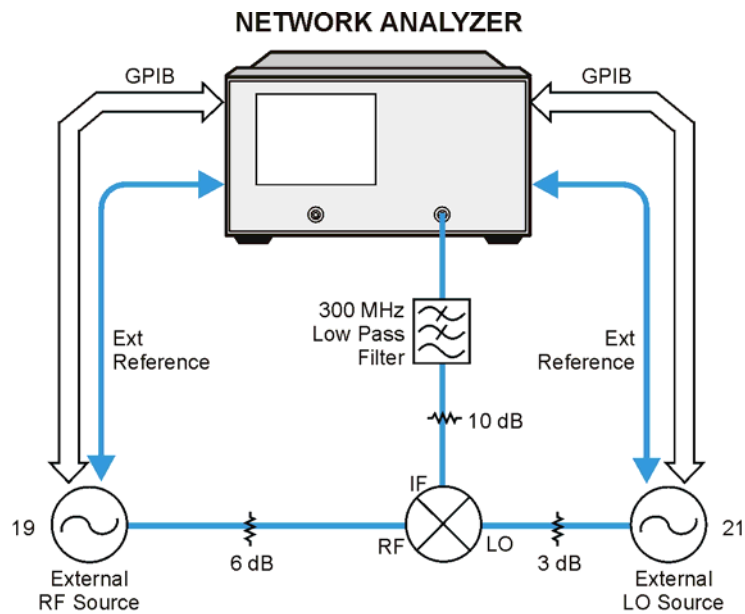

pa546e

Making Mixer Measurements (Option 089 Only)
Fixed IF Mixer Measurements

When the sequences are finished you should have a result as shown in [Figure 2-23](#).

Figure 2-23 Example Fixed IF Mixer Measurement

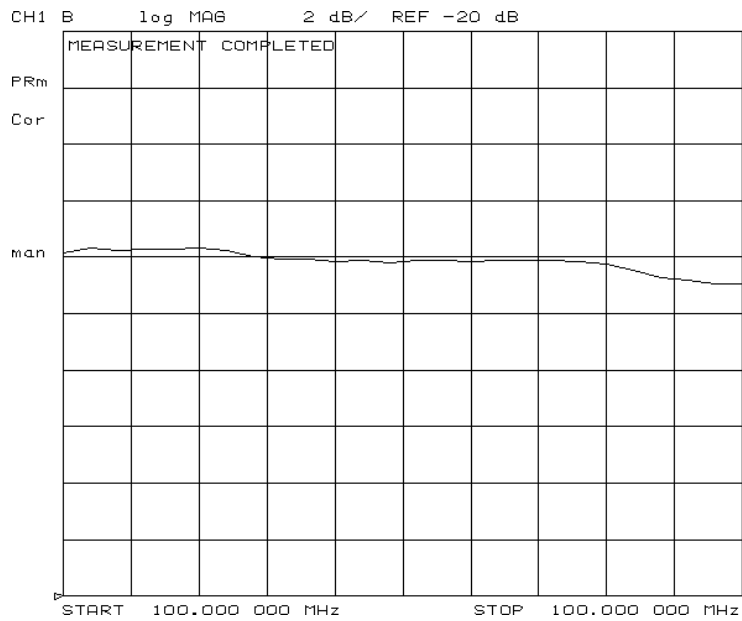

The displayed trace represents the conversion loss of the mixer at 26 points. Each point corresponds to one of the 26 different sets of RF and LO frequencies that were used to create the same fixed IF frequency.

Phase or Group Delay Measurements

For information on group delay principles, refer to ["Setting the Electrical Delay" on page 1-37](#).

Phase Measurements

When you are making linear measurements, you must provide a reference for determining phase by splitting the RF source power and send part of the signal into the reference channel. (This does not work for frequency offset measurements, since the source and receiver are functioning at different frequencies.)

To provide a reference signal for the phase measurement, you need a second mixer. This mixer is driven by the same RF and LO signals that are used to drive the mixer under test. The IF output from the reference mixer is applied to the reference (R) channel of the analyzer.

Phase Linearity and Group Delay

Group delay is the rate of change of phase through a device with respect to frequency ($d\phi/d\omega$). Traditionally, group delay has been used to describe the propagation delay (τ_g), and deviation from linear phase through a linear device. However, this parameter also contains valuable information about transmission delay and distortion through a non-linear device such as a mixer or frequency converter. For example, flat group delay corresponds to low modulation distortion (that is, carrier and sidebands propagate at the same rate).

Phase linearity and group delay are both measurements of the distortion of a transmitted signal. Both measure the non-linearity of a device's phase response with respect to frequency.

In standard vector error-correction, a thru (delay=0) is used as a calibration standard. The solution to this problem is to use a calibration mixer with very small group delay as the calibration standard.

Phase or Group Delay Measurements

An important characteristic to remember when selecting a calibration mixer is that the delay of the device should be kept as low as possible. To do this, select a mixer with very wide bandwidth (wider bandwidth results in smaller delay). The accuracy of this measurement depends on the quality of the mixer that is being used for calibration and how well this mixer has been characterized. The following measurement must be performed with a broadband calibration mixer that has a known group delay. The following table lists the specifications of two mixers that may be used for calibration:

Model Number	Useful Frequency Range	Group Delay
ANZAC MCD-123	0.03 to 3 GHz	0.5 ns
Mini-Circuits ZFM-4	dc to 1250 MHz	0.6 ns

1. Set the LO source to the desired CW frequency of 1000 MHz and power level to 13 dBm.
2. Initialize the analyzer by pressing **(Preset)**.
3. Set the analyzer's LO frequency to match the frequency of the LO source by pressing:

(System) **INSTRUMENT MODE** **FREQ OFFS MENU**
LO FREQUENCY **(1000)** **(M/μ)**

4. From the front panel of the analyzer, set the desired receiver frequency and source output power by pressing:

(Center) **(300)** **(M/μ)**
(Span) **(100)** **(M/μ)**
(Power) **(0)** **PWR RANGE MAN** **(x1)** **(-10)** **(x1)**, 8722ES)

5. Connect the instruments as shown in [Figure 2-24](#), placing a broadband "calibration" mixer (ZFM-4) between PORT 1 and PORT 2.

CAUTION To prevent connector damage, use an adapter (part number 1250-1462) as a connector saver for R CHANNEL IN.

Figure 2-24 Connections for a Group Delay Measurement

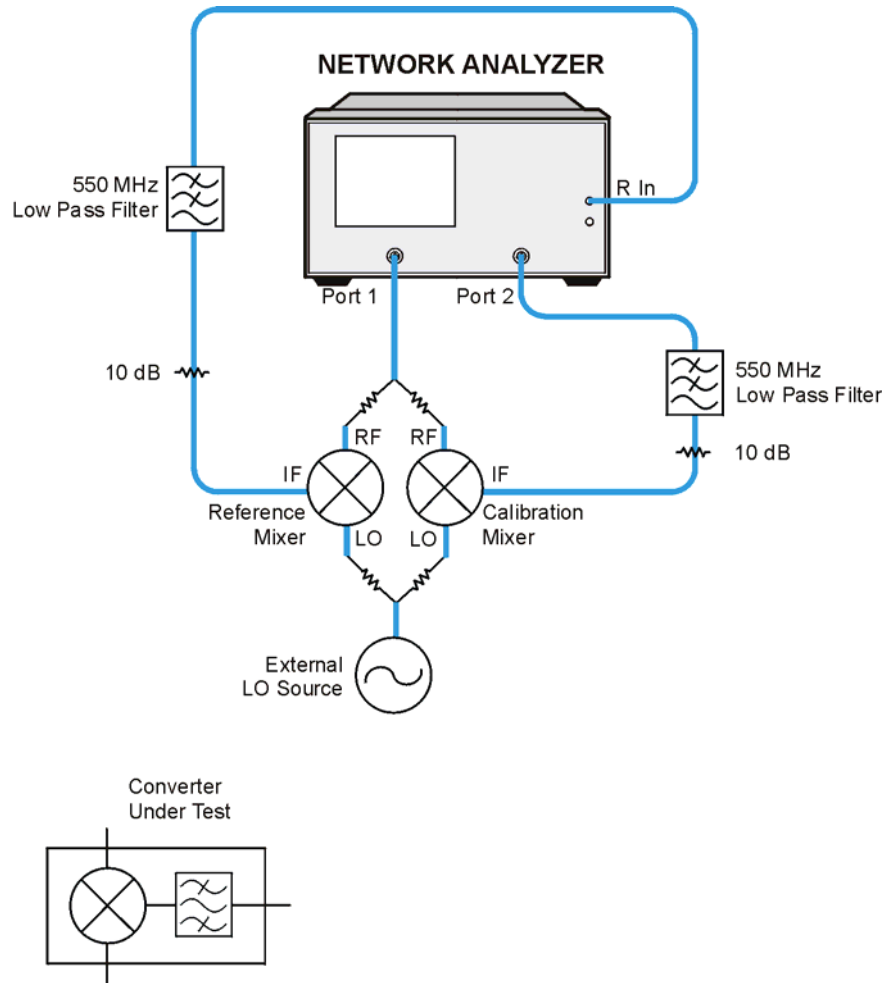

pa550e

6. To select the converter type and a high-side LO measurement configuration, press:

System INSTRUMENT MODE FREQ OFFS MENU
DOWN CONVERTER RF<LO FREQ OFFS ON

7. To view the measurement results on the analyzer's display, press:

System INSTRUMENT MODE FREQ OFFS MENU VIEW MEASURE

8. To select the format type, press:

Format DELAY

9. To make a response error-correction, press:

Meas INPUT PORTS B/R
Cal CALIBRATE MENU RESPONSE THRU

Making Mixer Measurements (Option 089 Only)
Phase or Group Delay Measurements

10. Replace the "calibration" mixer with the device under test. If measuring group delay, set the delay equal to the "calibration" mixer delay (for example -0.6 ns) by pressing:

Scale Ref

ELECTRICAL DELAY

-06 G/n

11. Scale the data for best vertical resolution.

Scale Ref

AUTOSCALE

Figure 2-25 Group Delay Measurement Example

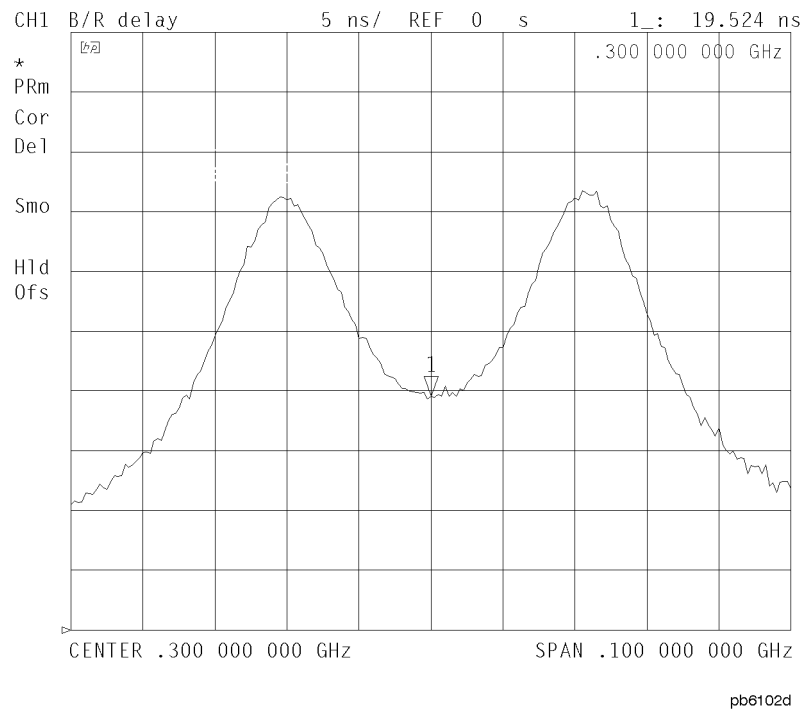

The displayed measurement trace shows the device under test delay, relative to the "calibration" mixer. This measurement is also useful when the device under test has built-in filtering, which requires >30 dB range (the maximum of R input). PORT 1 to PORT 2 range is >100 dB.

Amplitude and Phase Tracking

The match between mixers is defined as the absolute difference in amplitude or phase response over a specified frequency range. The tracking between mixers is essentially how well the devices are matched over a specified interval. This interval may be a frequency interval or a temperature interval, or a combination of both.

You can make tracking measurements by ratioing the responses of two mixer conversion loss measurements. Then any difference you view in response is due to the mixers and not the measurement system.

Using the same measurement setup as in "Phase or Group Delay Measurements" on page 2-35, you can determine how well two mixers track each other in terms of amplitude and phase.

1. Repeat steps 1 through 8 of the previous section "Phase Linearity and Group Delay" on page 2-35, with the following exception:

In step 7, select **Format** **PHASE**.

2. Once the analyzer has displayed the measurement results, press **Display** **DATA→MEM**.
3. Replace the calibration mixer with the mixer under test.
4. Press **DATA/MEM**.

The resulting trace should represent the amplitude and phase tracking of the two mixers.

Figure 2-26 Connections for an Amplitude and Phase Tracking Measurement Between Two Mixers

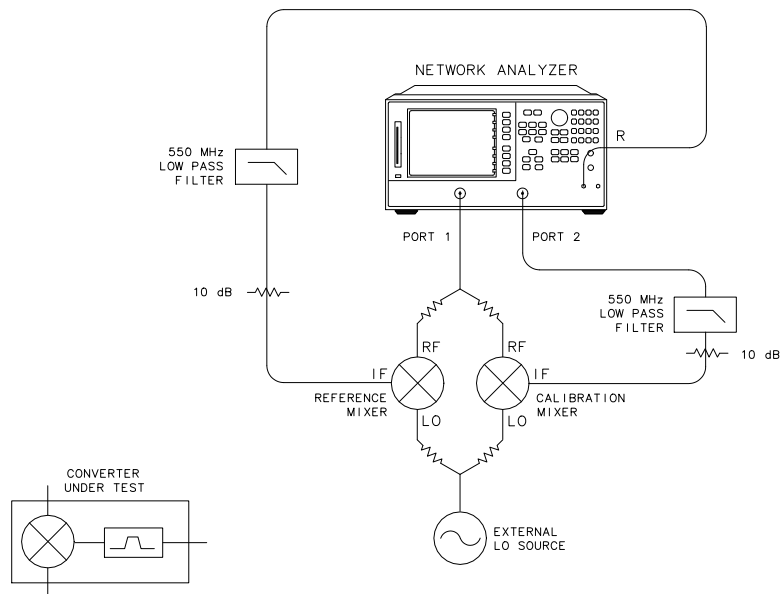

pg633e

Conversion Compression Using the Frequency Offset Mode

Conversion compression is a measure of the maximum RF input signal level where the mixer provides linear operation. The conversion loss is the ratio of the IF output level to the RF input level. This value remains constant over a specified input power range. When the input power level exceeds a certain maximum, the constant ratio between IF and RF power levels will begin to change. The point at which the ratio has decreased by 1 dB is called the 1 dB compression point. See [Figure 2-27](#).

Figure 2-27 Conversion Loss and Output Power as a Function of Input Power Level Example

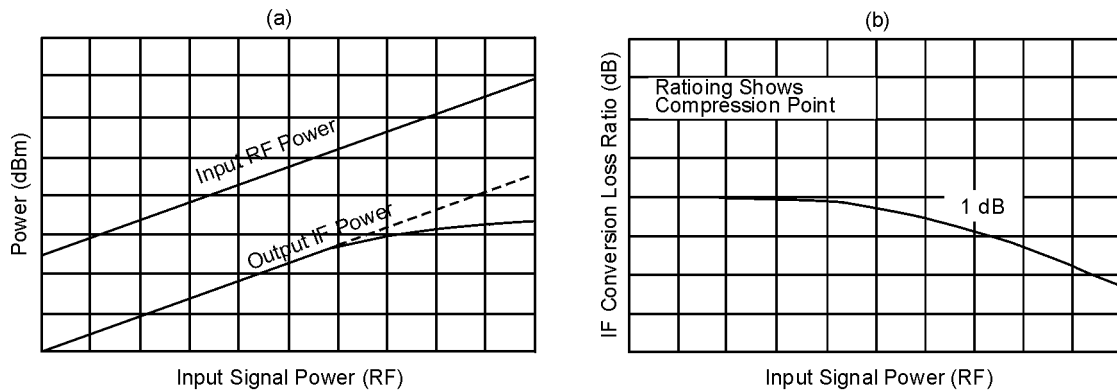

pa5158e

Notice that the IF output power increases linearly with the increasing RF signal, until mixer compression begins and the mixer saturates.

The following example uses a ratio of mixer output to input power and a marker search function to locate a mixer's 1 dB compression point.

NOTE Because this procedure was performed with an 8719ES/20ES, Option 007, the analyzer was able to produce an output power of +10 dBm.

If the default output power of your analyzer is not high enough to force the mixer under test into compression, then the following procedure may have to be performed with the addition of Option 007 or Option 085. Refer to the "[Making High Power Measurements with Option 085 \(ES Analyzers Only\)](#)" on page 1-59.

1. Set the LO source to the desired CW frequency of 600 MHz and power level to 13 dBm.
2. Initialize the analyzer by pressing **[Preset]**.
3. Set the analyzers LO frequency to match the frequency of the LO source by pressing:

[Sweep Setup]

SWEEP TYPE MENU **POWER SWEEP** **[Return]**

[System] **INSTRUMENT MODE** **FREQ OFFS MENU**

LO FREQUENCY **[800]** **[M/μ]**

4. To set the analyzer to the desired power sweep range, press:

Power

PWR RANGE MAN **POWER RANGES** **RANGE 0**

Start **-10** **x1**

Stop **10** **x1**

5. Make the connections, as shown in [Figure 2-28](#).

CAUTION To prevent connector damage, use an adapter (part number 1250-1462) as a connector saver for R CHANNEL IN.

Figure 2-28 Connections for the First Portion of Conversion Compression Measurement

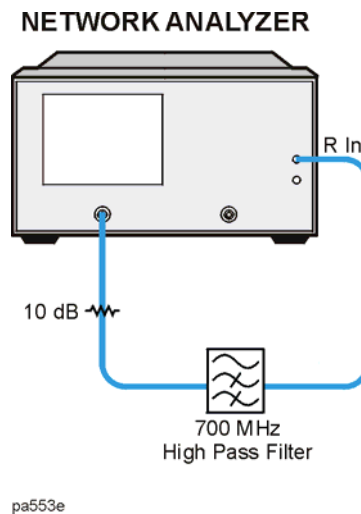

6. To view the absolute input power to the analyzer's R channel, press:

Meas **INPUT PORTS** **R**

7. To store a trace of the receiver power versus the source power into memory and view data/memory, press:

Display

DATA → MEM

DATA/MEM

This removes the loss between the output of the mixer and the input to the receiver, and provides a linear power sweep for use in subsequent measurements.

8. Make the connections as shown in [Figure 2-29](#).

CAUTION To prevent connector damage, use an adapter (part number 1250-1462) as a connector saver

for R CHANNEL IN.

Figure 2-29 Connections for the Second Portion of Conversion Compression Measurement

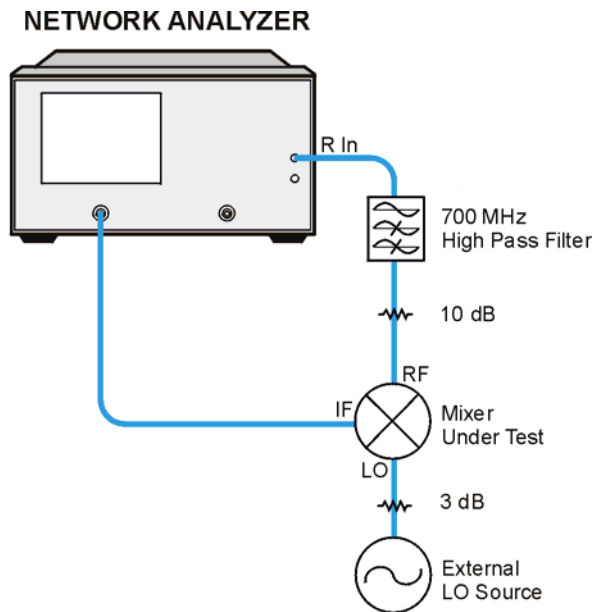

pa556e

9. To set the frequency offset mode LO frequency, press:



10. To select the converter type, press:



11. To select a low-side LO measurement configuration, press:



In this low-side LO, up converter measurement, the analyzer source frequency is offset lower than the receiver frequency. The analyzer source frequency can be determined from the following equation:

$$\text{receiver frequency (800 MHz)} - \text{LO frequency (600 MHz)} = 200 \text{ MHz}$$

The measurements setup diagram is shown in [Figure 2-30](#).

Figure 2-30 Measurement Setup Diagram Shown on Analyzer Display

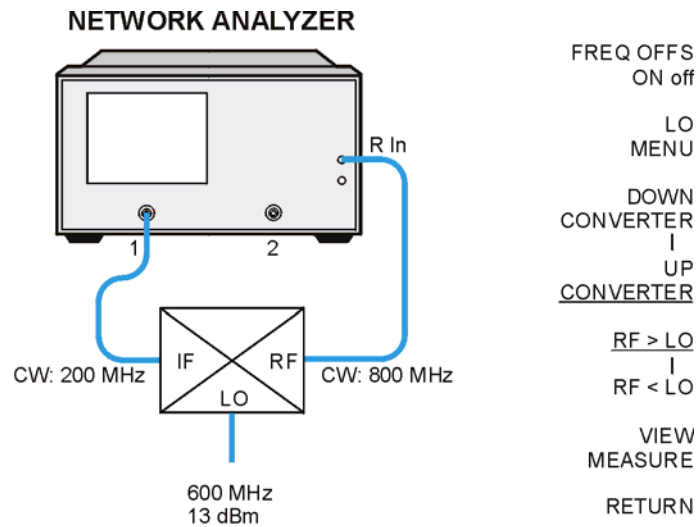

pa559e

12. To view the mixer's output power as a function of its input power, press:

VIEW MEASURE

13. To set up an active marker to search for the 1 dB compression point of the mixer, press:

Scale Ref

AUTO SCALE

Marker Search **SEARCH:MAX**

14. Press:

Marker **MKR ZERO**

Marker Search **TARGET** [-1] [x1]

Making Mixer Measurements (Option 089 Only)
Conversion Compression Using the Frequency Offset Mode

The measurement results show the mixer's 1 dB compression point. By changing the target value, you can easily locate other compression points (for example, 0.5 dB, 3 dB). See [Figure 2-31](#).

15. Read the compressed power on by turning marker Δ off.

Marker Δ MODE MENU Δ MODE OFF

Figure 2-31 Example Swept Power Conversion Compression Measurement

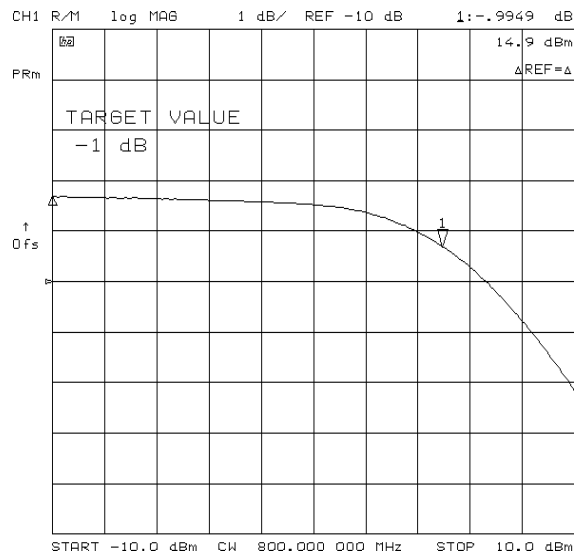

Isolation Example Measurements

Isolation is the measure of signal leakage in a mixer. Feedthrough is specifically the forward signal leakage to the IF port. High isolation means that the amount of leakage or feedthrough between the mixer's ports is very small. Isolation measurements do not use the frequency offset mode. Figure 2-32 illustrates the signal flow in a mixer.

Figure 2-32 Signal Flow in a Mixer Example

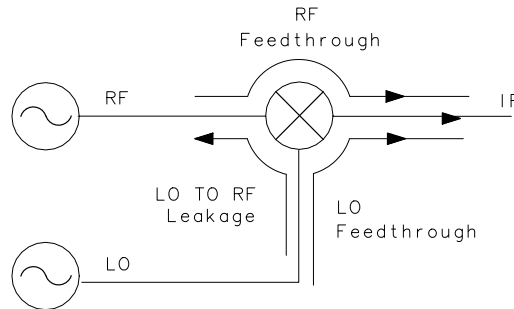

pg6105d

LO to RF Isolation

LO to RF isolation is the amount the LO power is attenuated when it appears directly at the RF port.

1. Initialize the analyzer by pressing **Preset**.
2. To select the analyzer frequency range and source power, press:

Start **10** **M/μ**

Stop **3000** **M/μ**

Power **0** **PWR RANGE MAN** **x1** **(-10)** **x1**, 8722ES)

This source stimulates the mixer's LO port.

3. To select a ratio B/R measurement, press:

Meas **INPUT PORTS** **B/R**

Making Mixer Measurements (Option 089 Only)
Isolation Example Measurements

4. Make the connections as shown in [Figure 2-33](#).

Figure 2-33 Connections for a Response Calibration

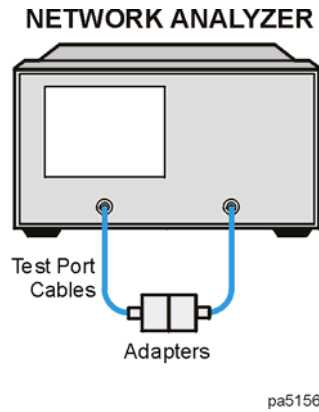

5. Perform a response calibration by pressing **Cal** **CALIBRATE MENU** **RESPONSE** **THRU**.

NOTE A full 2-port calibration will increase the accuracy of isolation measurements. Refer to [Chapter 5, "Optimizing Measurement Results."](#)

6. Make the connections as shown in [Figure 2-34](#).

CAUTION To get an accurate assessment of the LO-IF isolation, the proper LO power level must be input to the LO port.

Figure 2-34 Connections for a Mixer Isolation Measurement

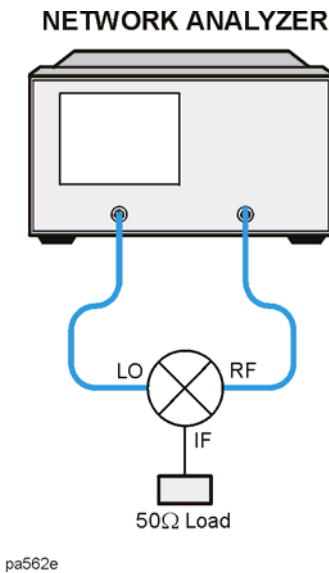

7. To adjust the display scale, press:

Scale Ref **AUTO SCALE**

The measurement results show the mixer's LO to RF isolation.

Figure 2-35 Example Mixer LO to RF Isolation Measurement

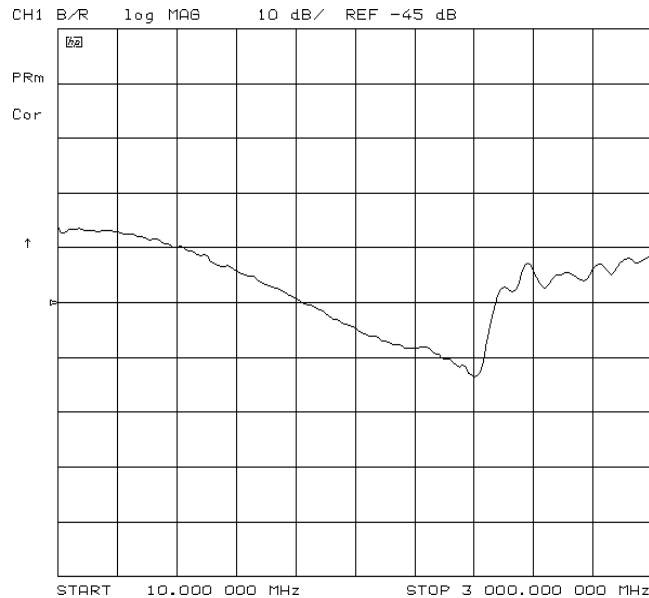

RF Feedthrough

The procedure and equipment configuration necessary for this measurement are very similar to those of the previous LO to RF Isolation procedure, with the addition of an external source to drive the mixer's LO port as we measure the mixer's RF feedthrough. RF feedthrough measurements do not use the frequency offset mode.

1. Select the CW LO frequency and source power from the front panel of the external source.

CW frequency = 300 MHz

Power = 10 dBm

2. Initialize the analyzer by pressing **Preset**.

3. To select the analyzer frequency range and source power, press:

Start **10** **M/μ**

Stop **3000** **M/μ**

Power **0** **PWR RANGE MAN** **x1** (**-10** **x1**, 8722ES)

This source stimulates the mixer's LO port.

4. To select a ratio B/R measurement, press:

Meas **INPUT PORTS** **B/R**

NOTE Isolation is dependent on LO power level and frequency. To ensure good test results, you should choose these parameters as close to actual operating conditions as possible.

5. Make the connections as shown in [Figure 2-36](#).

Figure 2-36 Connections for a Response Calibration

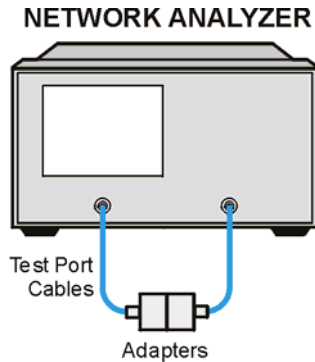

pa5156e

6. Perform a response calibration by pressing **Cal** **CALIBRATE MENU** **RESPONSE** **THRU**.
7. Make the connections as shown in [Figure 2-37](#).

Figure 2-37 Connections for a Mixer RF Feedthrough Measurement

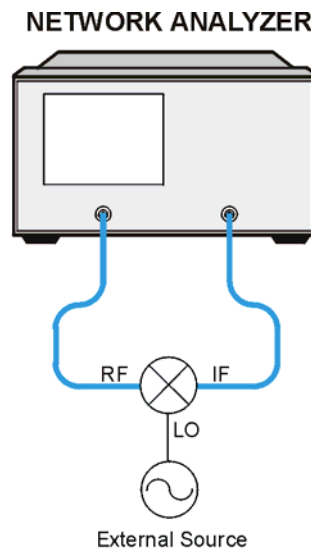

pa566e

8. Connect the external LO source to the mixer's LO port.
9. The measurement results show the mixer's RF feedthrough.

NOTE You may see spurious responses on the analyzer trace due to interference caused by LO to IF

leakage in the mixer. This can be reduced with averaging or by reducing the IF bandwidth.

Figure 2-38 Example Mixer RF Feedthrough Measurement

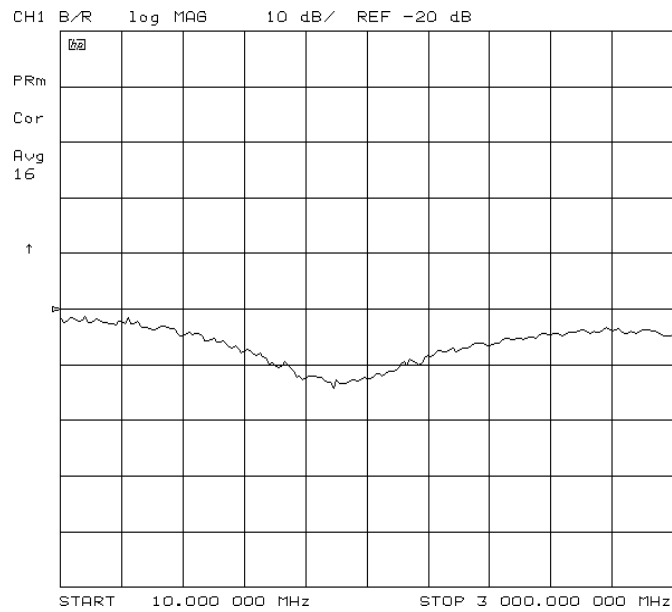

You can measure the IF to RF isolation in a similar manner, but with the following modifications:

- Use the analyzer source as the IF signal drive.
- View the leakage signal at the RF port.

SWR / Return Loss

Reflection coefficient (Γ) is defined as the ratio between the reflected voltage (V_r) and incident voltage (V_i). Standing wave ratio (SWR) is defined as the ratio of maximum standing wave voltage to the minimum standing wave voltage and can be derived from the reflection coefficient (Γ) using the following equation. Return loss can be derived from the reflection coefficient as well.

$$\Gamma = \frac{V_r}{V_i}$$

$$SWR = \frac{1 + |\Gamma|}{1 - |\Gamma|}$$

$$Return\ loss = -20 \log |\Gamma|$$

NOTE Mixers are three-port devices, and the reflection from any one port depends on the conditions of the other two ports. You should replicate the operating conditions the mixer will experience as closely as possible for the measurement. For all mixer SWR measurements, use the same power level that the mixer will use during normal operation.

When you measure the RF port SWR, you should have the LO drive level present and set to the expected frequency and power levels. Different LO drives and frequencies may yield different values for SWR at the same RF frequencies. The IF port should be terminated in a condition as close to its operating state as possible.

The measurements of LO port SWR and IF port SWR are very similar. For IF port SWR, you should terminate the RF port in a matched condition and apply the LO signal at its normal operating level. For the LO port SWR, the RF and IF ports should both be terminated in conditions similar to what will be present during normal operation.

3 Making Time Domain Measurements

Using This Chapter

This chapter contains the following:

- An introduction to time domain measurements
- Example procedures for making time domain transmission and reflection response measurements
- Information on the following time domain concepts:
 - "Time Domain Bandpass Mode" on page 3-12
 - "Time Domain Low Pass Mode" on page 3-15
 - "Transforming CW Time Measurements into the Frequency Domain" on page 3-21
 - "Masking" on page 3-25
 - "Windowing" on page 3-26
 - "Range" on page 3-29
 - "Resolution" on page 3-31
 - "Gating" on page 3-34

Introduction to Time Domain Measurements

The analyzers with Option 010 allow you to measure the time domain response of a device. Time domain analysis is useful for isolating a device problem in time or in distance. Time and distance are related by the velocity factor of your device under test (DUT) which is described in "Time Domain Bandpass Mode" on page 3-12.

The analyzer measures the frequency response of your device and uses an inverse Fourier transform (a mathematical calculation) to convert the frequency domain information into the time domain, with time as the horizontal display axis. The analyzer's internal computer makes this mathematical calculation using the chirp-Z Fourier transform technique.

The resulting measurement is the fully error-corrected time domain reflection or transmission response of the test device, displayed in near real-time. Response values (measured on the vertical axis) now appear separated in time or distance, providing valuable insight into the behavior of the test device beyond simple frequency characteristics.

With Option 010, the analyzer can transform frequency domain data to the time domain or time domain data to the frequency domain.

NOTE The analyzer can be ordered with Option 010, or the option can be added at a later date.

The transform used by the analyzer resembles time domain reflectometry (TDR) measurements. TDR measurements, however, are made by launching an impulse or step into the test device and observing the response in time with a receiver similar to an oscilloscope. In contrast, the analyzer makes swept frequency response measurements, and mathematically transforms the data into a TDR-like display.

Figure 3-1 illustrates the frequency and time domain reflection responses of a test device. The frequency domain reflection measurement is the composite of all the signals reflected by the discontinuities present in the test device over the measured frequency range.

Figure 3-1 Device Frequency Domain and Time Domain Reflection Responses

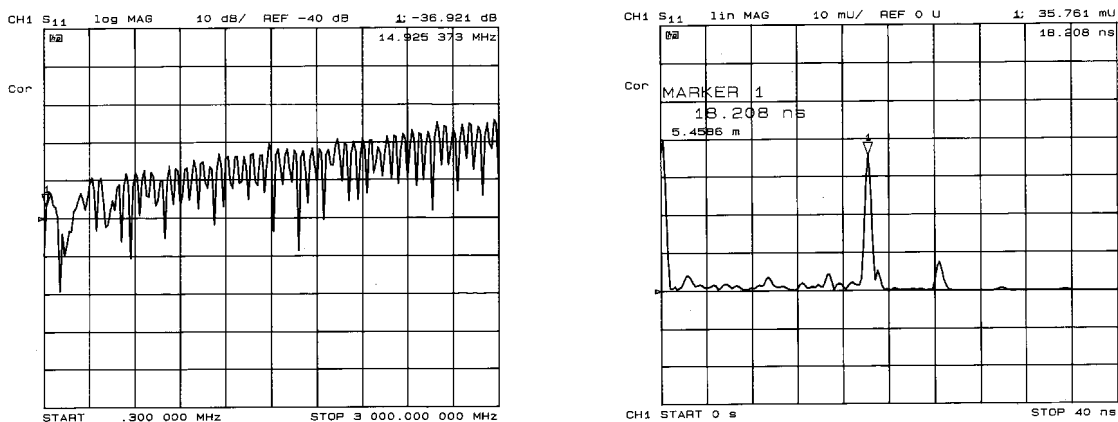

(a) Frequency Domain

(b) Time Domain Bandpass

pg6198_c

Making Time Domain Measurements

Introduction to Time Domain Measurements

The time domain measurement shows the effect of each discontinuity as a function of time (or distance), and shows that the test device response consists of three separate impedance changes. The second discontinuity has a reflection coefficient magnitude of 0.035 (i.e. 3.5% of the incident signal is reflected). Marker 1 on the time domain trace shows the elapsed time from the reference plane (where the calibration standards are connected) to the discontinuity and back: 18.2 nanoseconds.

The analyzer has three frequency-to-time transform modes:

- **Time domain bandpass mode** simulates the time domain response of an impulse input and is designed to measure band-limited devices. Although this mode is the easiest to use, it results in less time domain resolution than low pass mode, and may result in some magnitude errors at low frequencies when gating is used. For devices that are not band-limited, one of the low pass modes is recommended.
- **Time domain low pass step mode** simulates the time domain response of a step input. As in a traditional TDR measurement, the distance to the discontinuity in the test device, and the type of discontinuity (resistive, capacitive, inductive) can be determined.
- **Time domain low pass impulse mode** simulates the time domain response of an impulse input (like the bandpass mode). Both low pass modes yield better time domain resolution for a given frequency span than does the bandpass mode. In addition, when using the low pass modes, you can determine the type of discontinuity. However, these modes have certain limitations that are defined in "[Time Domain Bandpass Mode](#)" on page 3-12.

The analyzer has one time-to-frequency transform mode:

- **Forward transform mode** transforms CW signals measured over time into the frequency domain, to measure the spectral content of a signal. This mode is known as the CW time mode.

Making Transmission Response Measurements

In this example measurement there are three components of the transmission response:

- RF leakage at near zero time
- the main travel path through the device (1.6 μ s travel time)
- the "triple travel" path (4.8 μ s travel time)

This example procedure also shows you how time domain analysis allows you to mathematically remove individual parts of the time domain response to see the effect of potential design changes. This is accomplished by "gating" out the undesirable responses. With the "gating" capability, the analyzer time domain allows you to perform "what if" analysis by mathematically removing selected reflections and seeing the effect in the frequency domain.

1. Connect the device as shown in [Figure 3-2](#).

Figure 3-2 Device Connections for Time Domain Transmission Example Measurement

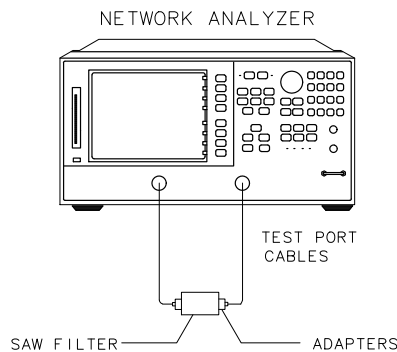

pg68e

2. To choose the measurement parameters, press:

Preset
Meas **Trans: FWD S21 (B/R)** or on ET models: **TRANSMISSN**
Start **119** **M/ μ**
Stop **149** **M/ μ**
Scale Ref **AUTO SCALE**

3. Substitute a thru for the device under test and perform a frequency response correction. Refer to [Chapter 6](#), "Calibrating for Increased Measurement Accuracy."
4. Reconnect your device under test.

Making Time Domain Measurements
Making Transmission Response Measurements

- To transform the data from the frequency domain to the time domain and set the sweep from 0 s to 6 μ s, press:

System **TRANSFORM MENU** **BANDPASS** **TRANSFORM ON**
Start **0** **G/n** **Stop** **6** **M/ μ**

The other time domain modes, low pass step and low pass impulse, are described in "Time Domain Low Pass Mode" on page 3-15.

- To better view the measurement trace, press:

Scale Ref **REFERENCE VALUE** and turn the front panel knob, or enter a value from the front panel keypad.

- To measure the peak response from the main path, press:

Marker Search **SEARCH: MAX**

The three responses shown in Figure 3-3 are the RF leakage near zero seconds, the main travel path through the filter, and the triple travel path through the filter. Only the combination of these responses was evident to you in the frequency domain.

Figure 3-3 Time Domain Transmission Example Measurement

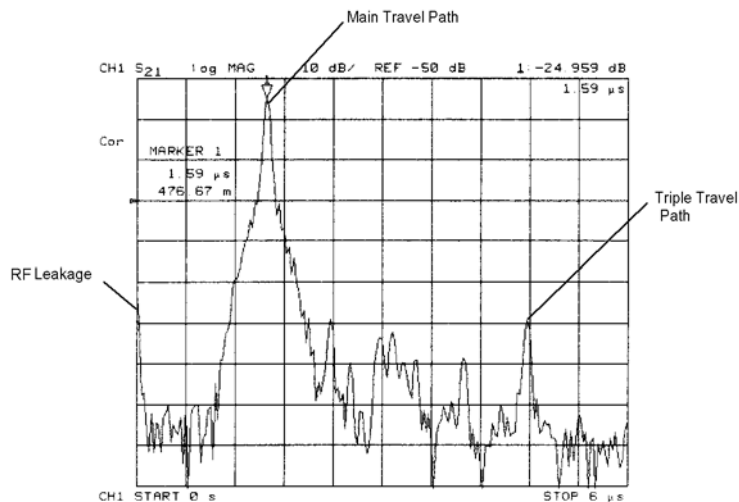

pa5165e

- To access the gate function menu, press:

System **TRANSFORM MENU** **SPECIFY GATE** **CENTER**

- To set the gate parameters, by entering the marker value, press:

1.6 **M/ μ** , or turn the front panel knob to position the center gate marker. This marker, shaped like a "T", is shown in Figure 3-4.

- To set the gate span, press:

Span **1.2** **M/ μ** or turn the front panel knob to position the "flag" gate markers.

11. To activate the gating function to remove any unwanted responses, press:

GATE ON

As shown in [Figure 3-4](#), only response from the main path is displayed.

NOTE You may remove the displayed response from inside the gate markers by pressing **SPAN** and turning the front panel knob to exchange the "flag" marker positions.

Figure 3-4 Gating in a Time Domain Transmission Example Measurement

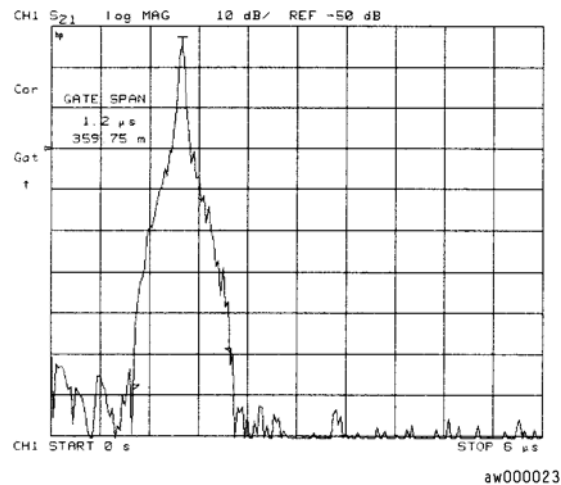

12. To adjust the gate shape for the best possible time domain response, press **GATE SHAPE** and select between minimum, normal, wide, and maximum. Each gate has a different passband flatness, cutoff rate, and sidelobe levels. A detailed discussion of gating and gate shape selections is located in ["Gating"](#) on page 3-34 and ["Selecting Gate Shape"](#) on page 3-35.

The passband ripple and sidelobe levels are descriptive of the gate shape. The cutoff time is the time between the stop time (−6 dB on the filter skirt) and the peak of the first sidelobe, and is equal on the left and right side skirts of the filter. The minimum gate span is just twice the cutoff time because it has no passband.

Figure 3-5 Gate Shape

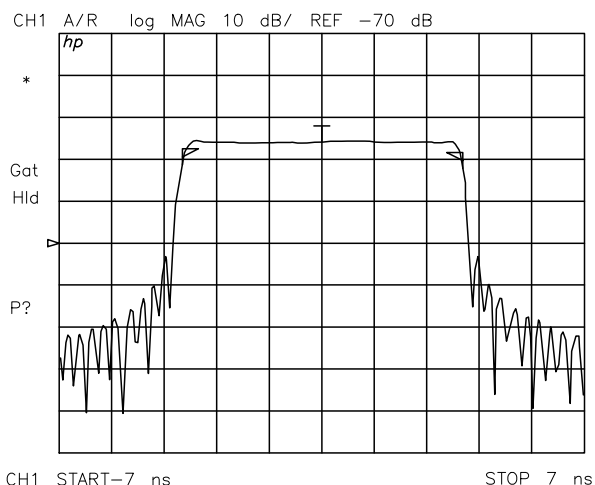

- To see the effect of the gating in the frequency domain, press:

TRANSFORM MENU **TRANSFORM OFF**
 AUTO SCALE
 DATA→MEM **DISPLAY: DATA AND MEMORY**
 TRANSFORM MENU **SPECIFY GATE** **GATE OFF**

This places the gated response in memory. [Figure 3-6](#) shows the effect of removing the RF leakage and the triple travel signal path using gating. By transforming back to the frequency domain, we see that this design change would yield better out-of-band rejection.

Figure 3-6 Gating Effects in a Frequency Domain Example Measurement

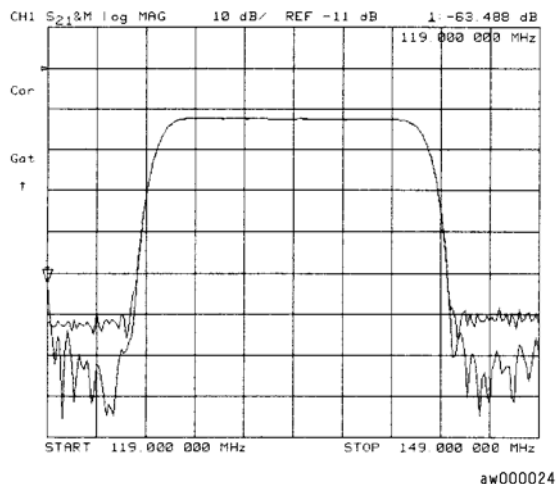

Making Reflection Response Measurements

The time domain response of a reflection measurement is often compared with the time domain reflectometry (TDR) measurements. Like the TDR, the analyzer measures the size of the reflections versus time (or distance). Unlike the TDR, the time domain capability of the analyzer allows you to choose the frequency range over which you would like to make the measurement.

1. To choose the measurement parameters, press:

Preset
Meas **Ref: FWD S11 (A/R)** or on ET models: **TRANSMISSN**
Start **50** **M/μ**
Stop **3** **G/n**

2. Perform an S_{11} 1-port correction on PORT 1. Refer to [Chapter 5, "Optimizing Measurement Results"](#) for a detailed procedure.
3. Connect your device under test as shown in [Figure 3-7](#).

Figure 3-7 Device Connections for Reflection Time Domain Example Measurement

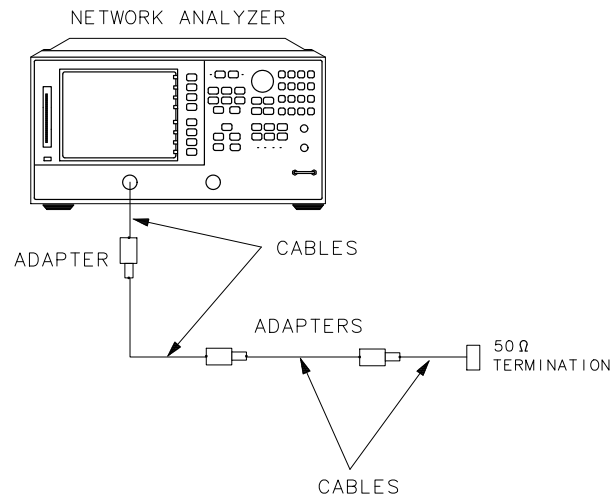

pg69e

4. To better view the measurement trace, press:

Scale Ref **AUTO SCALE**

[Figure 3-8](#) shows the frequency domain reflection response of the cables under test. The complex ripple pattern is caused by reflections from the adapters interacting with each other. By transforming this data to the time domain, you can determine the magnitude of the reflections versus distance along the cable.

Figure 3-8 Device Response in the Frequency Domain

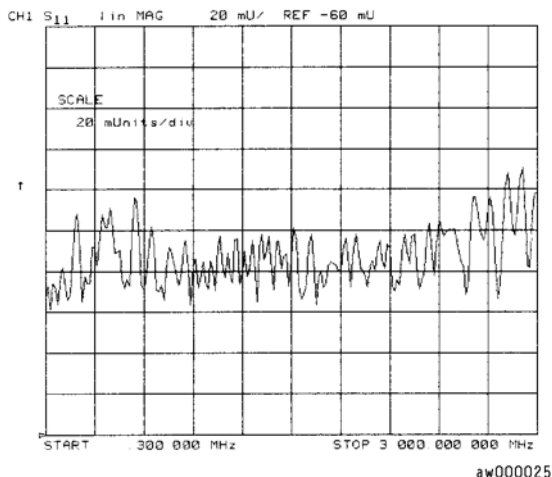

5. To transform the data from the frequency domain to the time domain, press:

System **TRANSFORM MENU** **BANDPASS** **TRANSFORM ON**

6. To view the time domain over the length (<4 meters) of the cable under test, press:

Format **LIN MAG**
Start **0** **x1**
Stop **35** **G/n**

The stop time corresponds to the length of the cable under test. The energy travels about 1 foot per nanosecond, or 0.3 meter/ns, in free space. Most cables have a relative velocity of about 0.66 the speed in free space. Calculate about 3 ns/foot, or 10 ns/meter, for the stop time when you are measuring the return trip distance to the cable end.

7. To enter the relative velocity of the cable under test, press **Cal** **MORE** **VELOCITY FACTOR** and enter a velocity factor for your cable under test.

NOTE Most cables have a relative velocity of 0.66 (for polyethylene dielectrics) or 0.7 (for PTFE dielectrics). If you would like the markers to read actual one-way distance rather than return trip distance, enter one-half the actual velocity factor. Then the markers will read the actual one-way distance to the reflection of interest rather than the "electrical length" that assumes a relative velocity of 1.

$$Velocity\ Factor = \frac{1}{\sqrt{\epsilon_r}}$$

where ϵ_r is the relative permittivity of the cable dielectric.

- To position the marker on the reflection of interest, press:

Marker and turn the front panel knob, or enter a value from the front panel keypad.

In this example, the velocity factor was set to one-half the actual value, so the marker reads the time and distance to the reflection.

- To position a marker at each reflection of interest, as shown in [Figure 3-9](#), press:

MARKER 2 **MARKER 3** **MARKER 4**, turning the front panel knob or entering a value from the front panel keypad after each key press.

Figure 3-9 Device Response in the Time Domain

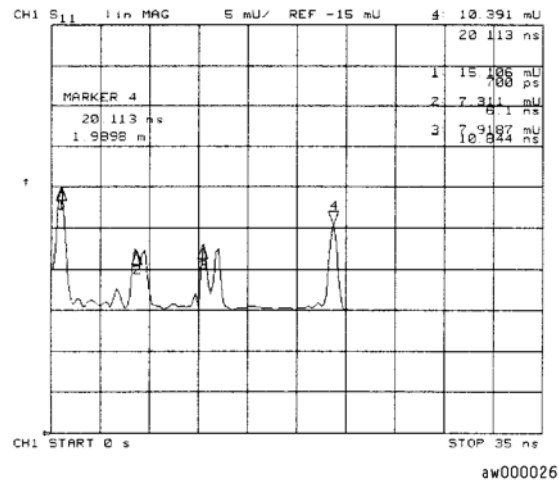

Time Domain Bandpass Mode

This mode is called bandpass because it works with band-limited devices. Traditional TDR requires that the test device be able to operate down to dc. Using bandpass mode, there are no restrictions on the measurement frequency range. Bandpass mode characterizes the test device impulse response.

Adjusting the Relative Velocity Factor

A marker provides both the two-way time and the two-way electrical length (or distance) to a discontinuity. The distance displayed is based on the assumption that the signal travels at the speed of light. The signal travels slower than the speed of light in most media (e.g. coax cables). This slower velocity (relative to light) can be compensated for by adjusting the analyzer relative velocity factor. To determine the physical length, rather than the electrical length, change the velocity factor to that of the medium under test:

1. Press **Cal** **MORE** **VELOCITY FACTOR**.
2. Enter a velocity factor between 0 and 1.0 (1.0 corresponds to the speed of light in a vacuum). Most cables have a velocity factor of 0.66 (polyethylene dielectrics) or 0.70 (PTFE dielectrics).

NOTE To cause the markers to read the actual one-way distance to a discontinuity, rather than the two-way distance, enter one-half the actual velocity factor.

Reflection Measurements Using Bandpass Mode

The bandpass mode can transform reflection measurements to the time domain. [Figure 3-10](#) (left) shows a typical frequency response reflection measurement of two sections of cable. [Figure 3-10](#) (right) shows the same two sections of cable in the time domain using the bandpass mode.

Figure 3-10 A Reflection Measurement of Two Cables

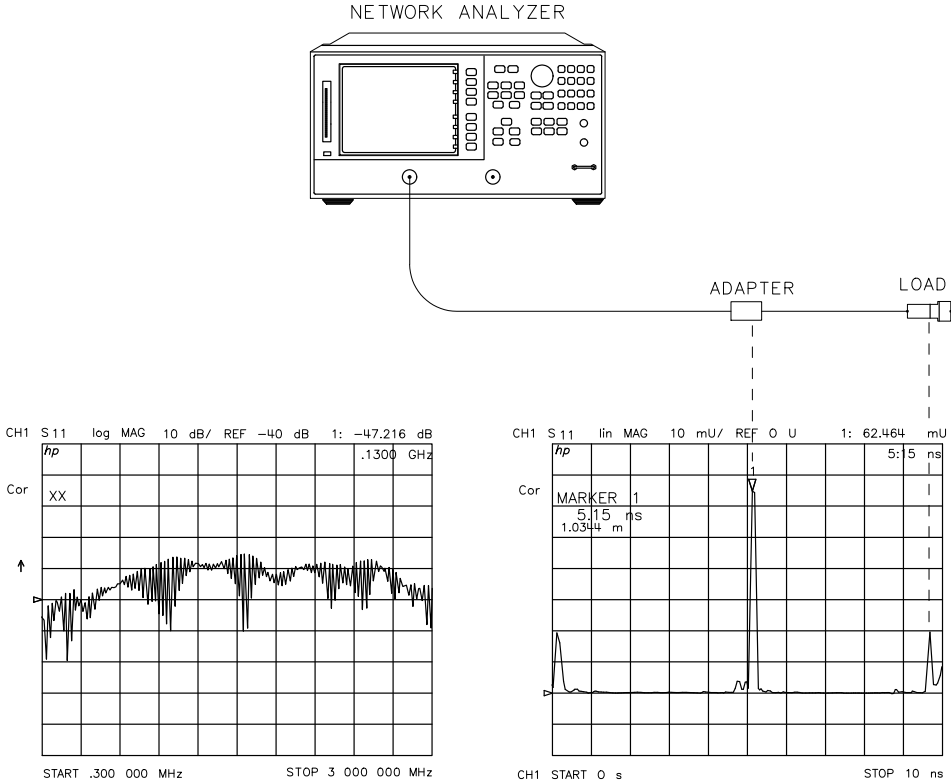

pg643e

The ripples in reflection coefficient versus frequency in the frequency domain measurement are caused by the reflections at each connector "beating" against each other.

One at a time, loosen the connectors at each end of the cable and observe the response in both the frequency domain and the time domain. The frequency domain ripples increase as each connector is loosened, corresponding to a larger reflection adding in and out of phase with the other reflections. The time domain responses increase as you loosen the connector that corresponds to each response.

Interpreting the Bandpass Reflection Response Horizontal Axis

In bandpass reflection measurements, the horizontal axis represents the time it takes for an impulse launched at the test port to reach a discontinuity and return to the test port (the two-way travel time). In [Figure 3-10](#), each connector is a discontinuity.

Interpreting the Bandpass Reflection Response Vertical Axis

The quantity displayed on the vertical axis depends on the selected format. The common formats are listed in [Table 3-1](#). The default format is LOG MAG (logarithmic magnitude), which displays the return loss in decibels (dB). LIN MAG (linear magnitude) is a format that displays the response as reflection coefficient ρ . This can be thought of as an average reflection coefficient of the discontinuity over the frequency range of the measurement. Use the REAL format only in low pass mode.

Table 3-1 Time Domain Reflection Formats

Format	Parameter
LIN MAG	Reflection Coefficient (unitless) ($0 < \rho < 1$)
REAL	Reflection Coefficient (unitless) ($-1 < \rho < 1$)
LOG MAG	Return Loss (dB)
SWR	Standing Wave Ratio (unitless)

Transmission Measurements Using Bandpass Mode

The bandpass mode can also transform transmission measurements to the time domain. For example, this mode can provide information about a surface acoustic wave (SAW) filter that is not apparent in the frequency domain. [Figure 3-11](#) illustrates a time domain bandpass measurement of a 321 MHz SAW filter.

Figure 3-11 Transmission Measurement in Time Domain Bandpass Mode

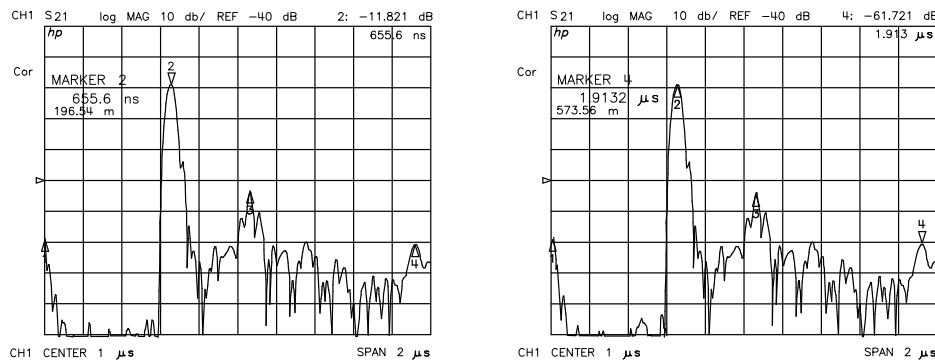

Interpreting the Bandpass Transmission Response Horizontal Axis

In time domain transmission measurements, the horizontal axis is displayed in units of time. The time axis indicates the propagation delay through the device. Note that in time domain transmission measurements, the value displayed is the actual delay (not twice the delay). The marker provides the propagation delay in both time and distance.

Marker 2 in [Figure 3-11](#) (left) indicates the main path response through the test device, which has a propagation delay of 655.6 ns, or about 196.5 meters in electrical length. Marker 4 in [Figure 3-11](#) (right) indicates the triple-travel path response at 1.91 μs, or about 573.5 meters. The response at marker 1 (at 0 seconds) is an RF feedthrough leakage path. In addition to the triple travel path response, there are several other multi-path responses through the test device, which are inherent in the design of a SAW filter.

Interpreting the Bandpass Transmission Response Vertical Axis

In the log magnitude format, the vertical axis displays the transmission loss or gain in dB; in the linear magnitude format it displays the transmission coefficient τ . Think of this as an average of the transmission response over the measurement frequency range.

Time Domain Low Pass Mode

This mode is used to simulate a traditional time domain reflectometry (TDR) measurement. It provides information to determine the type of discontinuity (resistive, capacitive, or inductive) that is present. Low pass provides the best resolution for a given bandwidth in the frequency domain. It may be used to give either the step or impulse response of the test device.

The low pass mode is less general-purpose than the bandpass mode because it places strict limitations on the measurement frequency range. The low pass mode requires that the frequency domain data points are harmonically related from dc to the stop frequency. That is, $stop = n \times start$, where n = number of points.

For example, with a start frequency of 50 MHz and 101 points, the stop frequency would be 5.05 GHz. Since the analyzer frequency range starts at 50 MHz, the dc frequency response is extrapolated from the lower frequency data. The requirement to pass dc is the same limitation that exists for traditional TDR.

Setting the Frequency Range for Time Domain Low Pass

Before a low pass measurement is made, the measurement frequency range must meet the ($stop = n \times start$) requirement previously described. The **SET FREQ LOW PASS** softkey performs this function automatically: the stop frequency is set close to the entered stop frequency, and the start frequency is set equal to $stop/n$.

If the low end of the measurement frequency range is critical, it is best to calculate approximate values for the start and stop frequencies before pressing **SET FREQ LOW PASS** and calibrating. This avoids distortion of the measurement results. To see an example, select the preset values of 201 points and a 50 MHz to 13.5 GHz frequency range. Now press **SET FREQ LOW PASS** and observe the change in frequency values. The stop frequency changes to 13.499 GHz, and the start frequency changes to 67.164 MHz. This would cause a distortion of measurement results for frequencies from 50 MHz to 67.164 MHz.

NOTE If the start and stop frequencies do not conform to the low pass requirement before a low pass mode (step or impulse) is selected and transform is turned on, the analyzer resets the start and stop frequencies. If error correction is on when the frequency range is changed, this turns it off. Therefore, set the frequency range for time domain low pass before performing a calibration.

Table 3-2 Minimum Frequency Ranges for Time Domain Low Pass

Number of Points	Minimum Frequency Range	Number of Points	Minimum Frequency Range
3	50 MHz to 150 MHz	101	50 MHz to 5.05 GHz
11	50 MHz to 550 MHz	201	50 MHz to 10.05 GHz
21	50 MHz to 1.05 GHz	401	50 MHz to 20.05 GHz
51	50 MHz to 2.55 GHz	801	50 MHz to 40.05 GHz

Minimum Allowable Stop Frequencies

The lowest analyzer measurement frequency is 50 MHz, therefore for each value of n there is a minimum

Making Time Domain Measurements

Time Domain Low Pass Mode

allowable stop frequency that can be used. That is, the minimum stop frequency = $n \times 50$ MHz. [Table 3-2](#) lists the minimum frequency range that can be used for each value of n for low pass time domain measurements.

Reflection Measurements in Time Domain Low Pass

[Figure 3-12](#) shows the time domain response of an unterminated cable in both the low-pass step and low-pass impulse modes.

Figure 3-12 Time Domain Low Pass Measurements of an Unterminated Cable

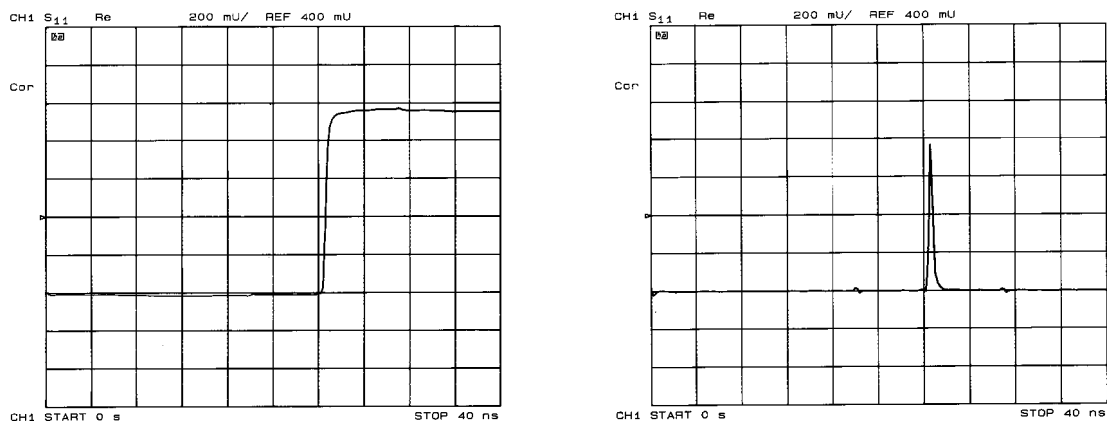

pg6197_c

Interpreting the Low Pass Response Horizontal Axis

The low pass measurement horizontal axis is the two-way travel time to the discontinuity (as in the bandpass mode). The marker displays both the two-way time and the electrical length along the trace. To determine the actual physical length, enter the appropriate velocity factor as described in ["Time Domain Bandpass Mode"](#) on page 3-12.

Interpreting the Low Pass Response Vertical Axis

The vertical axis depends on the chosen format. In the low pass mode, the frequency domain data is taken at harmonically related frequencies and extrapolated to dc. Because this results in the inverse Fourier transform having only a real part (the imaginary part is zero), the most useful low pass step mode format in this application is the real format. It displays the response in reflection coefficient units. This mode is similar to the traditional TDR response, which displays the reflected signal in a real format (volts) versus time (or distance) on the horizontal axis.



The real format can also be used in the low pass impulse mode, but for the best dynamic range for simultaneously viewing large and small discontinuities, use the log magnitude format.

Fault Location Measurements Using Low Pass

As described, the low pass mode can simulate the TDR response of the test device. This response contains information useful in determining the type of discontinuity present.

Figure 3-13 illustrates the low pass responses of known discontinuities. Each circuit element was simulated to show the corresponding low pass time domain S_{11} response waveform. The low pass mode gives the test device response either to a step or to an impulse stimulus. Mathematically, the low pass impulse stimulus is the derivative of the step stimulus.

Figure 3-13 Simulated Low Pass Step and Impulse Response Waveforms (Real Format)

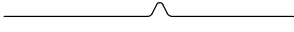
ELEMENT	STEP RESPONSE	IMPULSE RESPONSE
OPEN	 UNITY REFLECTION	 UNITY REFLECTION
SHORT	 UNITY REFLECTION, -180°	 UNITY REFLECTION, -180°
RESISTOR $R > Z_0$	 POSITIVE LEVEL SHIFT	 POSITIVE PEAK
RESISTOR $R < Z_0$	 NEGATIVE LEVEL SHIFT	 NEGATIVE PEAK
INDUCTOR	 POSITIVE PEAK	 POSITIVE THEN NEGATIVE PEAKS
CAPACITOR	 NEGATIVE PEAK	 NEGATIVE THEN POSITIVE PEAKS

pg6 127d

Figure 3-14 shows example cables with discontinuities (faults) using the low pass step mode with the real format.

Figure 3-14 Low Pass Step Measurements of Common Cable Faults (Real Format)

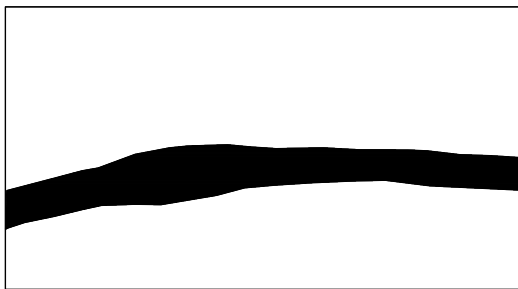
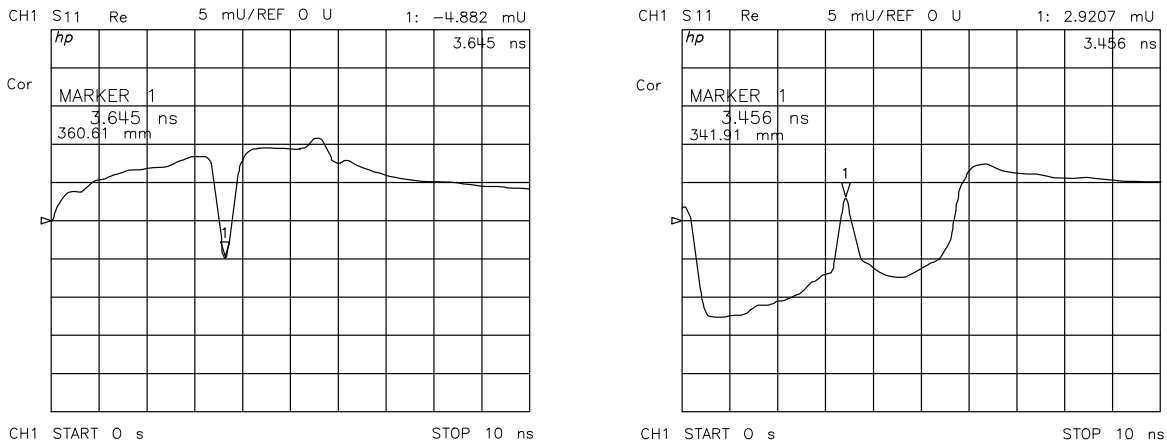

(a) Crimped Cable (Capacitive)

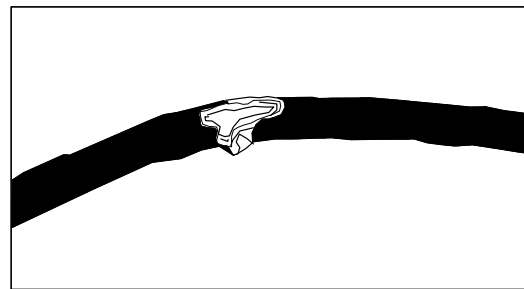

(b) Frayed Cable (Inductive)

pg6123d

Transmission Measurements in Time Domain Low Pass

Measuring Small Signal Transient Response Using Low Pass Step

Use the low pass mode to analyze the test device's small signal transient response. The transmission response of a device to a step input is often measured at lower frequencies, using a function generator (to provide the step to the test device) and a sampling oscilloscope (to analyze the test device output response). The low pass step mode extends the frequency range of this type of measurement to the maximum frequency of the analyzer.

The step input shown in [Figure 3-15](#) is the inverse Fourier transform of the frequency domain response of a thru measured at calibration. The step rise time is proportional to the highest frequency in the frequency domain sweep; the higher the frequency, the faster the rise time. The frequency sweep in [Figure 3-15](#) is from 10 MHz to 1 GHz.

[Figure 3-15](#) also illustrates the time domain low pass response of an amplifier under test. The average group delay over the measurement frequency range is the difference in time between the step and the amplifier response. This time domain response simulates an oscilloscope measurement of the amplifier's small signal transient response. Note the ringing in the amplifier response that indicates an under-damped design.

Figure 3-15 Time Domain Low Pass Measurement of an Amplifier Small Signal Transient Response

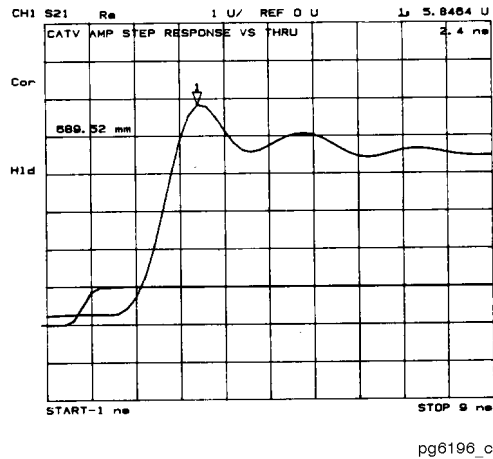

Interpreting the Low Pass Step Transmission Response Horizontal Axis

The low pass transmission measurement horizontal axis displays the average transit time through the test device over the frequency range used in the measurement. The response of the thru connection used in the calibration is a step that reaches 50% unit height at approximately time = 0. The rise time is determined by the highest frequency used in the frequency domain measurement. The step is a unit high step, which indicates no loss for the thru calibration. When a device is inserted, the time axis indicates the propagation delay or electrical length of the device. The markers read the electrical delay in both time and distance. The distance can be scaled by an appropriate velocity factor as described in ["Time Domain Bandpass Mode" on page 3-12](#).

Interpreting the Low Pass Step Transmission Response Vertical Axis

In the real format, the vertical axis displays the transmission response in real units (for example, volts). For the amplifier example in [Figure 3-15](#), if the amplifier input is a step of 1 volt, the output, 2.4 nanoseconds after the step (indicated by marker 1), is 5.84 volts.

In the log magnitude format, the amplifier gain is the steady state value displayed after the initial transients die out.

Measuring Separate Transmission Paths through the Test Device Using Low Pass Impulse Mode

The low pass impulse mode can be used to identify different transmission paths through a test device that has a response at frequencies down to dc (or at least has a predictable response, above the noise floor, below 50 MHz).

For example, use the low pass impulse mode to measure the relative transmission times through a multi-path device such as a power divider. Another example is to measure the pulse dispersion through a broadband transmission line, such as a fiber optic cable. Both examples are illustrated in [Figure 3-16](#). The horizontal and vertical axes can be interpreted as already described in ["Time Domain Bandpass Mode" on page 3-12](#).

Figure 3-16 Transmission Measurements Using Low Pass Impulse Mode

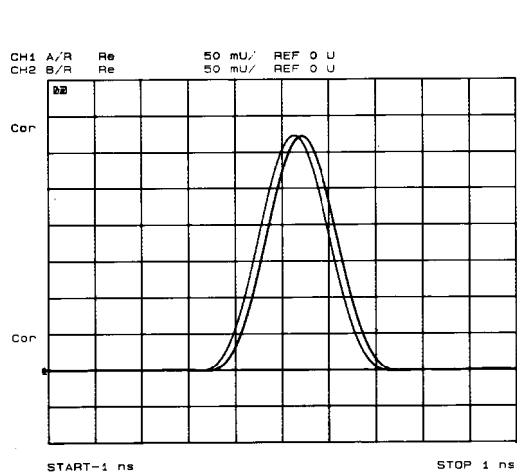

(a) Comparing Transmission Paths through a Power Divider

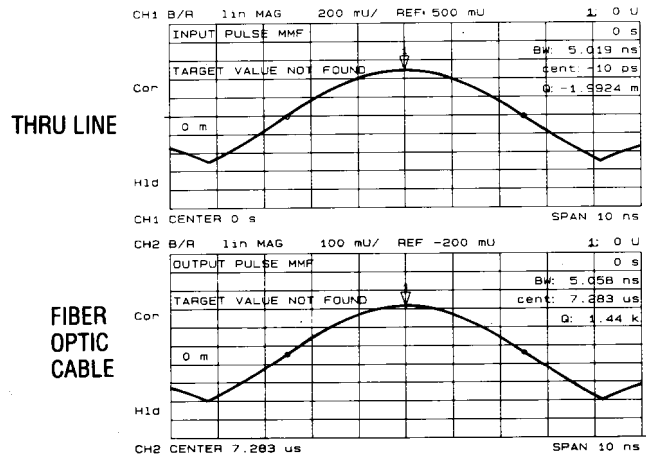

(b) Measuring Pulse Dispersion on a 1.5 km Fiber Optic Cable

pg6195_c

Transforming CW Time Measurements into the Frequency Domain

The analyzer can display the amplitude and phase of CW signals versus time. For example, use this mode for measurements such as amplifier gain as a function of warmup time (i.e. drift). The analyzer can display the measured parameter (e.g. amplifier gain) for periods of up to 24 hours and then output the data to a digital plotter for hardcopy results.

These "strip chart" plots are actually measurements as a function of time (time is the independent variable), and the horizontal display axis is scaled in time units. Transforms of these measurements result in frequency domain data. Such transforms are called forward transforms because the transform from time to frequency is a forward Fourier transform, and can be used to measure the spectral content of a CW signal. For example, when transformed into the frequency domain, a pure CW signal measured over time appears as a single frequency spike. The transform into the frequency domain yields a display that looks similar to a spectrum analyzer display of signal amplitude versus frequency.

Forward Transform Measurements

Figure 3-17 shows an example of a measurement using the Fourier transform in the forward direction, from the time domain to the frequency domain.

Figure 3-17 Amplifier Gain Measurement

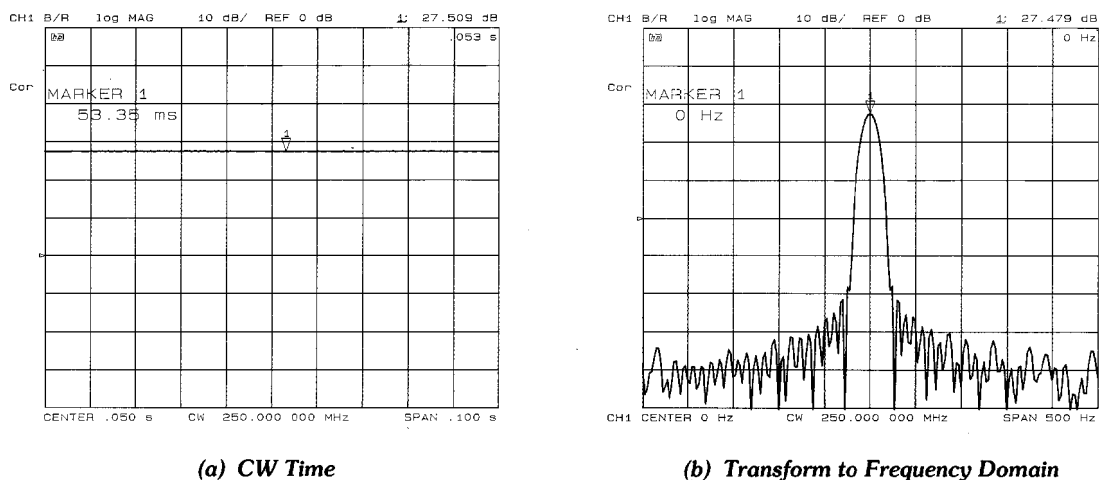

pg6189_c

Interpreting the Forward Transform Vertical Axis

With the log magnitude format selected, the vertical axis displays dB. This format simulates a spectrum analyzer display of power versus frequency.

Interpreting the Forward Transform Horizontal Axis

In a frequency domain transform of a CW time measurement, the horizontal axis is measured in units of

Transforming CW Time Measurements into the Frequency Domain

frequency. The center frequency is the offset of the CW frequency. For example, with a center frequency of 0 Hz, the CW frequency (250 MHz in the example) is in the center of the display. If the center frequency entered is a positive value, the CW frequency shifts to the right half of the display; a negative value shifts it to the left half of the display. The span value entered with the transform on is the total frequency span shown on the display. (Alternatively, the frequency display values can be entered as start and stop.)

Demodulating the Results of the Forward Transform

The forward transform can separate the effects of the CW frequency modulation amplitude and phase components. For example, if a test device modulates the transmission response (S_{21}) with a 500 Hz AM signal, you can see the effects of that modulation as shown in [Figure 3-18](#). To simulate this effect, apply a 500 Hz sine wave to the analyzer rear panel EXT AM input.

Figure 3-18 Combined Effects of Amplitude and Phase Modulation

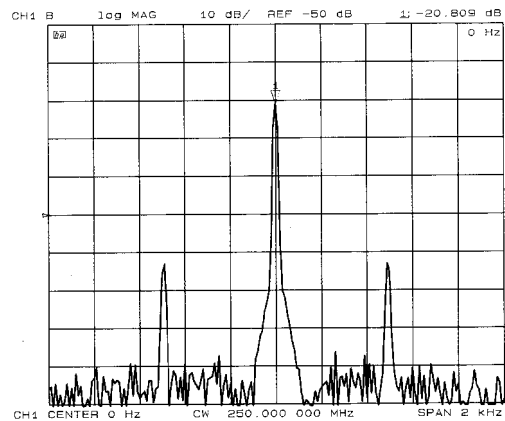

pg6187_c

Using the demodulation capabilities of the analyzer, it is possible to view the amplitude or the phase component of the modulation separately. The window menu includes the following softkeys to control the demodulation feature:

DEMOD: OFF is the normal preset state, in which both the amplitude and phase components of any test device modulation appear on the display.

AMPLITUDE displays only the amplitude modulation, as illustrated in [Figure 3-19a](#).

PHASE displays only the phase modulation, as shown in [Figure 3-19b](#).

Figure 3-19 Separating the Amplitude and Phase Components of Test-Device-Induced Modulation

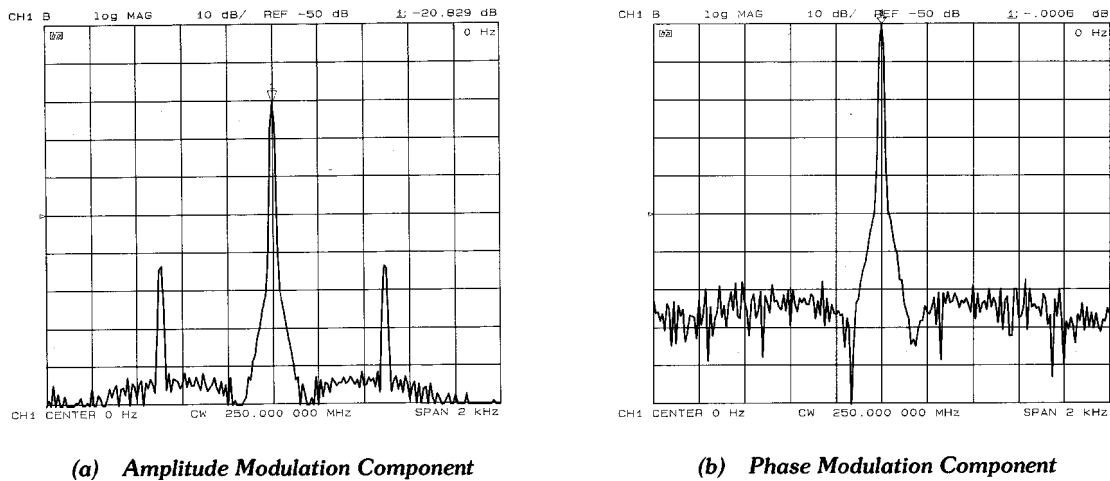

pg6188_c

Forward Transform Range

In the forward transform (from CW time to the frequency domain), range is defined as the frequency span that can be displayed before aliasing occurs, and is similar to range as defined for time domain measurements. In the range formula, substitute time span for frequency span.

$$Range = \frac{Number\ of\ points - 1}{time\ span}$$

$$Range = \frac{201 - 1}{200 \times 10^{-3}}$$

$$Range = 1000\ Hertz$$

For the example, a 201 point CW time measurement made over a 200 ms time span, choose a span of 1 kHz or less on either side of the center frequency (see Figure 3-20). That is, choose a total span of 2 kHz or less.

Figure 3-20 Range of a Forward Transform Measurement

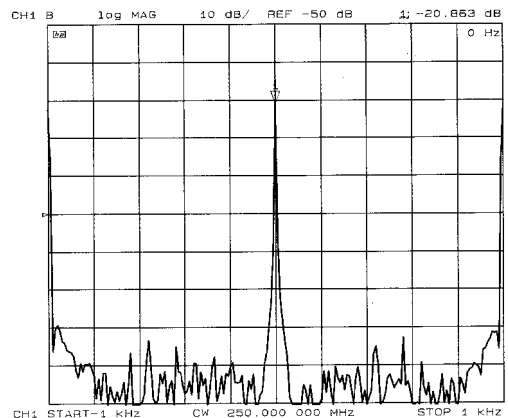

pg6186_c

To increase the frequency domain measurement range, increase the span. The maximum range is inversely proportional to the sweep time, therefore it may be necessary to increase the number of points or decrease the sweep time. Because increasing the number of points increases the auto sweep time, the maximum range is 2 kHz on either side of the selected CW time measurement center frequency (4 kHz total span). To display a total frequency span of 4 kHz, enter the span as 4000 Hz.

Masking

Masking occurs when a discontinuity (fault) closest to the reference plane affects the response of each subsequent discontinuity. This happens because the energy reflected from the first discontinuity never reaches subsequent discontinuities. For example, if a transmission line has two discontinuities that each reflect 50% of the incident voltage, the time domain response (real format) shows the correct reflection coefficient for the first discontinuity ($\rho=0.50$). However, the second discontinuity appears as a 37.5% reflection ($\rho=0.375$) because only some of the incident voltage reached the second discontinuity, and some of that reflected energy is reflected off the first discontinuity as it returns. For two discrete discontinuities, the apparent reflection of the second discontinuity appears as approximately $\hat{\rho}_2 = (1 - \rho_1^2) \cdot \rho_2$, where $\hat{\rho}_2$ is the apparent reflection of the second discontinuity, ρ_1 is the reflection of the first discontinuity, and ρ_2 is the reflection of the second discontinuity.

NOTE This example assumes a lossless transmission line. Real transmission lines, with non-zero loss, attenuate signals as a function of the distance from the reference plane.

As an example of masking due to line loss, consider the time domain response of a 3 dB attenuator and a short circuit. The impulse response (log magnitude format) of the short circuit alone is a return loss of 0 dB, as shown in Figure 3-21a. When the short circuit is placed at the end of the 3 dB attenuator, the return loss is -6 dB, as shown in Figure 3-21b. This value actually represents the forward and return path loss through the attenuator, and illustrates how a lossy network can affect the responses that follow it.

Figure 3-21 Masking Example

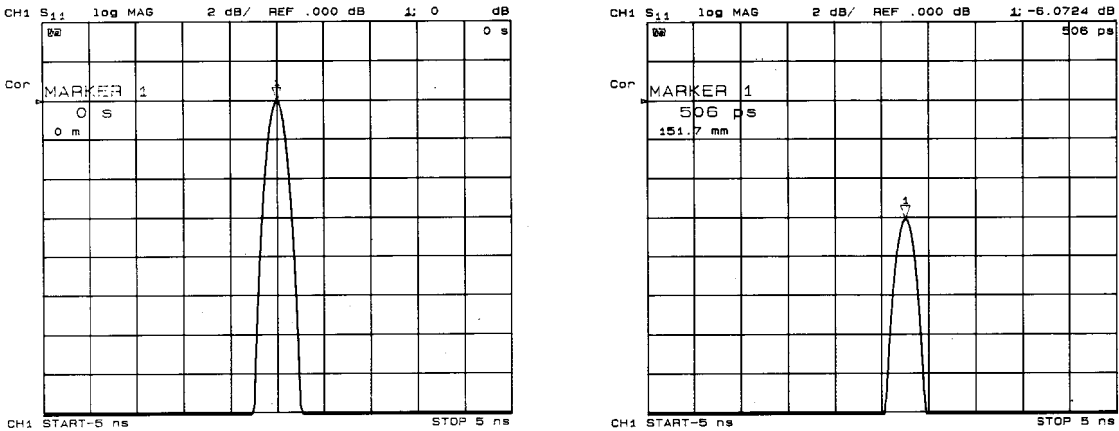

(a) Short Circuit

(b) Short Circuit at the End of a 3 dB Pad

pg6194_c

Windowing

The analyzer provides a windowing feature that makes time domain measurements more useful for isolating and identifying individual responses. Windowing is needed because of the abrupt transitions in a frequency domain measurement at the start and stop frequencies. The band limiting of a frequency domain response causes overshoot and ringing in the time domain response, and causes a non-windowed impulse stimulus to have a $\sin(kt)/kt$ shape, where $k = \pi/\text{frequency span}$ and $t = \text{time}$ (see [Figure 3-22](#)). This has two effects that limit the usefulness of the time domain measurement:

- **Finite impulse width (or rise time).** Finite impulse width limits the ability to resolve between two closely spaced responses. The effects of the finite impulse width cannot be improved without increasing the frequency span of the measurement (see [Table 3-3](#)).

Figure 3-22 Impulse Width, Sidelobes, and Windowing

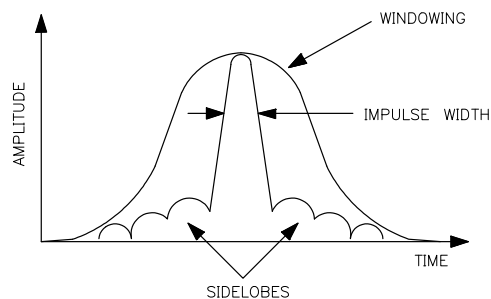

pg665d

- **Sidelobes.** The impulse sidelobes limit the dynamic range of the time domain measurement by hiding low-level responses within the sidelobes of higher level responses. The effects of sidelobes can be improved by windowing (see [Table 3-3](#)).

Windowing improves the dynamic range of a time domain measurement by filtering the frequency domain data prior to converting it to the time domain, producing an impulse stimulus that has lower sidelobes. This makes it much easier to see time domain responses that are very different in magnitude. The sidelobe reduction is achieved, however, at the expense of increased impulse width. The effect of windowing on the step stimulus (low pass mode only) is a reduction of overshoot and ringing at the expense of increased rise time.

To select a window, press **System** **TRANSFORM MENU** **WINDOW** . A menu is presented that allows the selection of three window types, see [Table 3-3](#).

Table 3-3 Impulse Width, Sidelobe Level, and Windowing Values

Window Type	Impulse Sidelobe Level	Low Pass Impulse Width (50%)	Step Sidelobe Level	Step Rise Time (10 – 90%)
Minimum	–13 dB	0.60/Freq Span	–21 dB	0.45/Freq Span
Normal	–44 dB	0.98/Freq Span	–60 dB	0.99/Freq Span
Maximum	–75 dB	1.39/Freq Span	–70 dB	1.48/Freq Span

NOTE: The bandpass mode simulates an impulse stimulus. Bandpass impulse width is twice that of low pass impulse width. The bandpass impulse sidelobe levels are the same as low pass impulse sidelobe levels.

Choose one of the three window shapes listed or use the knob to select any windowing pulse width (or rise time for a step stimulus) between the softkey values. The time domain stimulus sidelobe levels depend only on the window selected.

- MINIMUM** is essentially no window. Consequently, it gives the highest sidelobes.
- NORMAL** (the preset mode) gives reduced sidelobes and is the mode most often used.
- MAXIMUM** window gives the minimum sidelobes, providing the greatest dynamic range.
- USE MEMORY on OFF** remembers a user-specified window pulse width (or step rise time) different from the standard window values.

A window is activated only for viewing a time domain response, and does not affect a displayed frequency domain response. [Figure 3-23](#) shows the typical effects of windowing on the time domain response of a short circuit reflection measurement.

Figure 3-23 The Effects of Windowing on the Time Domain Responses of a Short Circuit (Real Format)

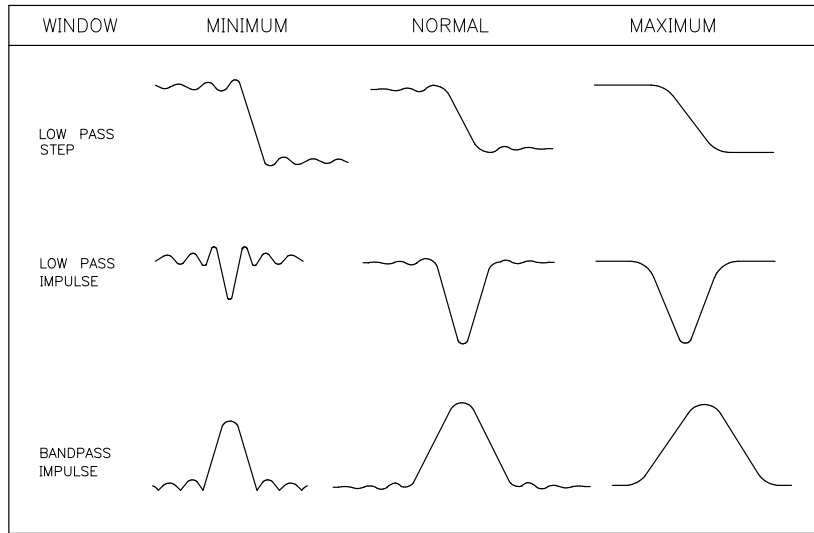

pb664d

Range

In the time domain, range is defined as the length in time that a measurement can be made without encountering a repetition of the response, called aliasing. A time domain response repeats at regular intervals because the frequency domain data is taken at discrete frequency points, rather than continuously over the frequency band.

$$\text{Measurement range} = \frac{1}{\Delta F}$$

where ΔF is the spacing between frequency data points

$$\text{Measurement range} = \frac{(\text{number of points} - 1)}{\text{frequency span(Hz)}}$$

For example:

$$\text{Measurement} = 201 \text{ points}$$

$$\text{Frequency Span} = 1 \text{ GHz to } 3 \text{ GHz}$$

$$\text{Frequency Spacing } (\Delta F) = 10 \text{ MHz}$$

$$\text{Range} = \frac{1}{\Delta F} \text{ or } \frac{(\text{number of points} - 1)}{\text{frequency span}}$$

$$\text{Range} = \frac{1}{(10 \times 10^6)} \text{ or } \frac{(201 - 1)}{(2 \times 10^9)}$$

$$\text{Range} = 100 \times 10^{-9} \text{ seconds}$$

$$\text{Electrical Length} = \text{range} \times \text{the speed of light} \left(3 \times 10^8 \frac{m}{s}\right)$$

$$\text{Electrical Length} = \left(100 \times 10^{-9} \text{ s}\right) \times \left(3 \times 10^8 \frac{m}{s}\right)$$

$$\text{Electrical Length} = 30 \text{ meters}$$

Making Time Domain Measurements

Range

In this example, the range is 100 ns, or 30 meters electrical length. To prevent the time domain responses from overlapping, the test device must be 30 meters or less in electrical length for a transmission measurement (15 meters for a reflection measurement). The analyzer limits the stop time to prevent the display of aliased responses.

To increase the time domain measurement range, first increase the number of points, but remember that as the number of points increases, the sweep speed decreases. Decreasing the frequency span also increases range, but reduces resolution.

Resolution

Two different resolution terms are used in the time domain:

- response resolution
- range resolution

Response Resolution

Time domain response resolution is defined as the ability to resolve two closely-spaced responses, or a measure of how close two responses can be to each other and still be distinguished from each other. For responses of equal amplitude, the response resolution is equal to the 50% (–6 dB) impulse width. It is inversely proportional to the measurement frequency span, and is also a function of the window used in the transform. The approximate formulas for calculating the 50% impulse width are given in [Table 3-3](#). For example, using the formula for the bandpass mode with a normal windowing function for a 50 MHz to 13.05 GHz measurement (13.0 GHz span):

$$50 \text{ percent calculated impulse width} = \frac{0.98}{13.0(\text{GHz})} \times 2$$

$$= 0.151 \text{ nanoseconds}$$

$$\text{Electrical length (in air)} = \left(0.151 \times 10^{-9} \text{ s} \right) \times \left(30 \times 10^9 \frac{\text{cm}}{\text{s}} \right)$$

$$= 4.53 \text{ centimeters}$$

With this measurement, two equal responses can be distinguished when they are separated by at least 4.53 centimeters. In a measurement with a 20 GHz span, two equal responses can be distinguished when they are separated by at least 2.94 cm. Using the low pass mode (the low pass frequencies are slightly different) with a minimum windowing function, you can distinguish two equal responses that are about 1.38 centimeters or more apart.

For reflection measurements, which measure the two-way time to the response, divide the response resolution by 2. Using this example, you can distinguish two faults of equal magnitude provided they are 0.69 centimeters (electrical length) or more apart.

NOTE Remember, to determine the physical length, the relative velocity factor of the transmission medium under test must be entered into the electrical length equation.

Making Time Domain Measurements

Resolution

For example, a cable with a PTFE dielectric (0.7 relative velocity factor), measured under the conditions stated above, has a fault location measurement response resolution of 0.45 centimeters. This is the maximum fault location response resolution. Factors such as reduced frequency span, greater frequency domain data windowing, and a large discontinuity shadowing the response of a smaller discontinuity, all act to degrade the effective response resolution.

Figure 3-24 illustrates the effects of response resolution. The solid line shows the actual reflection measurement of two approximately equal discontinuities (the input and output of an SMA barrel). The dashed line shows the approximate effect of each discontinuity, if they could be measured separately.

Figure 3-24 Response Resolution

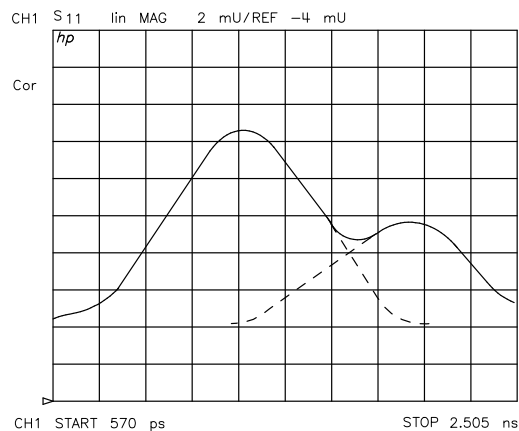

pg682d

While increasing the frequency span increases the response resolution, keep the following points in mind:

- The time domain response noise floor is directly related to the frequency domain data noise floor. Because of this, if the frequency domain data points are taken at or below the measurement noise floor, the time domain measurement noise floor is degraded.
- The time domain measurement is an average of the response over the frequency range of the measurement. If the frequency domain data is measured out-of-band, the time domain measurement is also the out-of-band response.

You may (with these limitations in mind) choose to use a frequency span that is wider than the test device bandwidth to achieve better resolution.

Range Resolution

Time domain range resolution is defined as the ability to locate a single response in time. If only one response is present, range resolution is a measure of how closely you can pinpoint the peak of that response. The range resolution is equal to the digital resolution of the display, which is the time domain span divided by the number of points on the display. To get the maximum range resolution, center the response on the display and reduce the time domain span. The range resolution is always much finer than the response resolution (see [Figure 3-25](#)).

Figure 3-25 Range Resolution of a Single Discontinuity

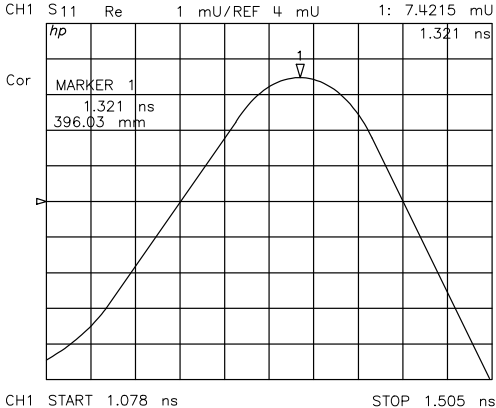

pg683d

Gating

Gating provides the flexibility of selectively removing time domain responses. The remaining time domain responses can then be transformed back to the frequency domain. For reflection (or fault location) measurements, use this feature to remove the effects of unwanted discontinuities in the time domain. You can then view the frequency response of the remaining discontinuities. In a transmission measurement, you can remove the effects of multiple transmission paths.

Figure 3-26a shows the frequency response of an electrical airline and termination. Figure 3-26b shows the response in the time domain. The discontinuity on the left is due to the input connector. The discontinuity on the right is due to the termination. We want to remove the effect of the connector so that we can see the frequency response of just the airline and termination. Figure 3-26c shows the gate applied to the connector discontinuity. Figure 3-26d shows the frequency response of the airline and termination, with the connector "gated out."

Figure 3-26 Sequence of Steps in Gating Operation
GATING OPERATION

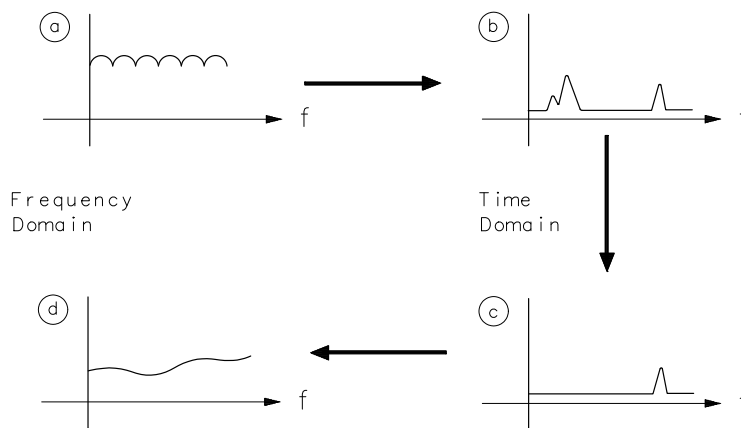

pb666d

Setting the Gate

Think of a gate as a bandpass filter in the time domain (see Figure 3-27). When the gate is on, responses outside the gate are mathematically removed from the time domain trace. Enter the gate position as a start and stop time (not frequency) or as a center and span time. The start and stop times are the bandpass filter -6 dB cutoff times. Gates can have a negative span, in which case the responses inside the gate are mathematically removed. The gate's start and stop flags define the region where gating is *on*.

Figure 3-27 Gate Shape

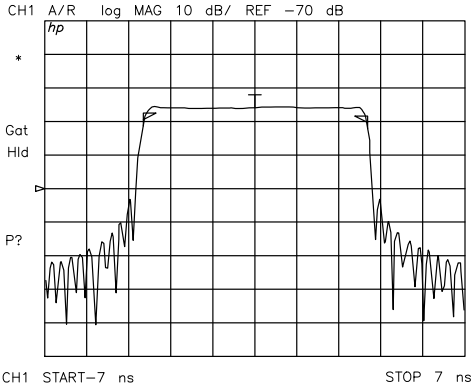

pg6121d

Selecting Gate Shape

The four gate shapes available are listed in [Table 3-4](#). Each gate has a different passband flatness, cutoff rate, and sidelobe levels.

Table 3-4 Gate Characteristics

Gate Shape	Passband Ripple	Sidelobe Levels	Cutoff Time	Minimum Gate Span
Gate Span				
Minimum	±0.10 dB	-48 dB	1.4/Freq Span	2.8/Freq Span
Normal	±0.10 dB	-68 dB	2.8/Freq Span	5.6/Freq Span
Wide	±0.10 dB	-57 dB	4.4/Freq Span	8.8/Freq Span
Maximum	±0.10 dB	-70 dB	12.7/Freq Span	25.4/Freq Span

Note: With 1601 frequency points, gating is available only in the bandpass mode.

The passband ripple and sidelobe levels are descriptive of the gate shape. The cutoff time is the time between the stop time (-6 dB on the filter skirt) and the peak of the first sidelobe, and is equal on the left and right side skirts of the filter. As shown in [Table 3-4](#), the minimum gate span is just twice the cutoff time because it has no passband. Always choose a gate span wider than the minimum. For most applications, do not be concerned about the minimum gate span, simply use the knob to position the gate markers around the desired portion of the time domain trace.

Making Time Domain Measurements
Gating

4 Printing, Plotting, and Saving Measurement Results

Using This Chapter

This chapter contains instructions for the following tasks:

- Printing or plotting your measurement results
 - Configuring a print function
 - Defining a print function
 - Printing one measurement per page
 - Printing multiple measurements per page
 - Configuring a plot function
 - Defining a plot function
 - Plotting one measurement per page using a pen plotter
 - Plotting multiple measurements per page using a pen plotter
 - Plotting a measurement to disk
 - To view plot files on a PC
 - Outputting plot files from a PC to a plotter
 - Outputting plot files from a PC to an HP-GL compatible printer
 - Outputting single page plots using a printer
 - Outputting multiple plots to a single page using a printer
 - Plotting multiple measurements per page from disk
 - Titling the displayed measurement
 - Configuring the analyzer to produce a time stamp
 - Aborting a print or plot process
 - Printing or plotting the list values or operating parameters
 - Solving problems with printing or plotting
- Saving and recalling instrument states
 - Saving an instrument state
 - Saving measurement results
 - Re-saving an instrument state
 - Deleting a file
 - Renaming a file
 - Recalling a file
 - Formatting a disk
 - Solving problems with saving or recalling files

Printing or Plotting Your Measurement Results

You can print your measurement results to the following peripherals:

- printers with GPIB interfaces
- printers with parallel interfaces
- printers with serial interfaces

You can plot your measurement results to the following peripherals:

- HPGL compatible printers with GPIB interfaces
- HPGL compatible printers with parallel interfaces
- plotters with GPIB interfaces
- plotters with parallel interfaces
- plotters with serial interfaces

Most Hewlett-Packard desktop printers and plotters are compatible with the analyzer. For a list of recommended peripherals, refer to the configuration guide for your analyzer. The following Web site also contains a link to the configuration guide:

www.agilent.com/find/8720

A printer compatibility guide (an up-to-date list of printers that are compatible with the network analyzer) can be found at the following Web site:

www.agilent.com/find/pcg

Configuring a Print Function

All copy configuration settings are stored in non-volatile memory. Therefore, they are not affected if you press **Preset** or switch off the analyzer power.

1. Connect the printer to the interface port.

Figure 4-1 Printer Connections to the Analyzer

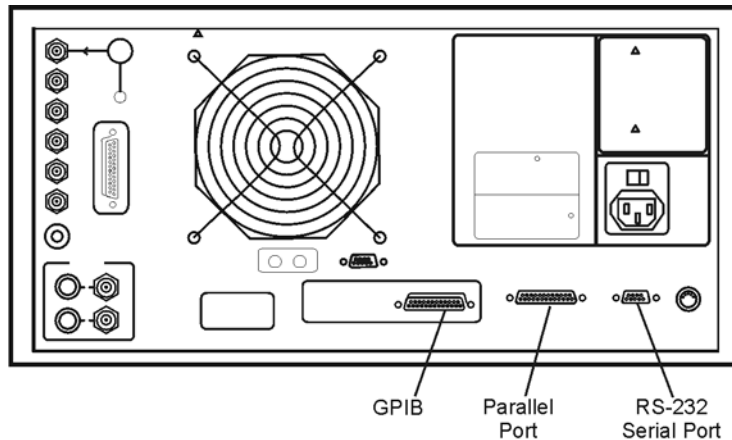

2. Press **Local** **SET ADDRESSES** **PRINTER PORT** **PRNTR TYPE** until the correct printer choice appears:
 - ThinkJet (QuietJet)
 - DeskJet (This supports most current models such as DeskJet 890C, DeskJet 895C, or DeskJet 1600C. See also DJ 540 selection.)
 - LaserJet (only LaserJet models III, 4, 5, and 6)
 - PaintJet
 - Epson-P2 (printers that conform to the ESC/P2 printer control language, such as Epson LQ-570)
 - DJ 540 (This can be used for printers that do not support 100 dots per inch (dpi) but do support 300 dpi such as HP DeskJet 540 or 850C.)

NOTE Selecting DJ 540 converts 100 dpi raster information to 300 dpi raster format. If your DeskJet printer does not support the 100 dpi raster format and your printing results seem to be smaller than the normal size (approximately one-half of the page), select DJ 540.

Information regarding a printer compatibility guide (an up-to-date list of printers that are compatible with the network analyzer) is available in ["Printing or Plotting Your Measurement Results" on page 4-3](#).

3. Select one of the following printer interfaces:

- Choose **PRNTR PORT GPIB** if your printer has a GPIB interface, and then configure the print function as follows:
 - a. Enter the GPIB address of the printer, followed by **(x1)**.
 - b. Press **(Local)** and **SYSTEM CONTROLLER** if there is no external controller connected to the GPIB bus.
 - c. Press **(Local)** and **USE PASS CONTROL** if there is an external controller connected to the GPIB bus.
- Choose **PARALLEL** if your printer has a parallel (Centronics) interface, and then configure the print function as follows:

Press **(Local)** and then select the parallel port interface function by pressing **PARALLEL** until the correct function appears.

 - If you choose **PARALLEL [COPY]**, the parallel port is dedicated for normal copy device use (printers or plotters).
 - If you choose **PARALLEL [GPIO]**, the parallel port is dedicated for general purpose I/O, and cannot be used for printing or plotting.
- Choose **SERIAL** if your printer has a serial (RS-232) interface, and then configure the print function as follows:
 - a. Press **PRINTER BAUD RATE** and enter the printer's baud rate, followed by **(x1)**.
 - b. To select the transmission control method that is compatible with your printer, press **XMIT CNTRL** (transmit control - handshaking protocol) until the correct method appears.
 - If you choose **Xon-Xoff**, the handshake method allows the printer to control the data exchange by transmitting control characters to the network analyzer.
 - If you choose **DTR-DSR**, the handshake method allows the printer to control the data exchange by setting the electrical voltage on one line of the RS-232 serial cable.

NOTE Because the **DTR-DSR** handshake takes place in the hardware rather than the firmware or software, it is the fastest transmission control method.

Defining a Print Function

NOTE The print definition is set to default values whenever the power is cycled. However, you can save the print definition by saving the instrument state.

1. Press **Copy** **DEFINE PRINT**.
 2. Press **PRINT: MONOCHROME** or **PRINT: COLOR**.
 - Choose **PRINT: MONOCHROME** if you are using a black and white printer, or you want just black and white from a color printer.
 - Choose **PRINT: COLOR** if you are using a color printer.
 3. Press **AUTO-FEED** until the correct choice (ON or OFF) is highlighted.
 - Choose **AUTO-FEED ON** if you want to print one measurement per page.
 - Choose **AUTO-FEED OFF** if you want to print multiple measurements per page.
-

NOTE Laser printers and some DeskJet printers do not begin to print until a full page, or a partial page and a form feed, have been received.

If You Are Using a Color Printer

1. Press **PRINT COLORS**.
 2. If you want to modify the print colors, select the print element and then choose an available color.
-

NOTE You can set all the print elements to black to create a hardcopy in black and white. Since the media color is usually white or clear, you could set a print element to white if you do not want that element to appear on your hardcopy.

To Reset the Printing Parameters to Default Values

1. Press **Copy** **DEFINE PRINT** **DEFAULT PRNT SETUP**.

Table 4-1 Default Values for Printing Parameters

Printing Parameter	Default
Printer Mode	Monochrome
Auto Feed	ON
Printer Colors	
Channel 1 and 3 Data	Magenta
Channel 1 and 3 Memory	Green
Channel 2 and 4 Data	Blue
Channel 2 and 4 Memory	Red
Graticule	Cyan
Warning	Black
Text	Black
Ref Line	Black

Printing One Measurement Per Page

1. Configure and define the print function, as explained in ["Configuring a Print Function" on page 4-4](#) and ["Defining a Print Function" on page 4-6](#).
2. Press **Copy** **PRINT MONOCHROME**.

If you defined the **AUTO-FEED OFF**, press **PRINTER FORM FEED** after the message COPY OUTPUT COMPLETED appears.

Printing Multiple Measurements Per Page

1. Configure and define the print function, as explained in "Configuring a Print Function" on page 4-4 and "Defining a Print Function" on page 4-6.
2. Press **Copy** **DEFINE PRINT** and then press **AUTO-FEED** until the softkey label appears as **AUTO-FEED OFF**.
3. Press **RETURN** **PRINT MONOCHROME** to print a measurement on the first half page.
4. Make the next measurement that you want to see on your hardcopy. Figure 4-2 shows an example of a hardcopy where two measurements appear.
5. Press **Copy** **PRINT MONOCHROME** to print a measurement on the second half page.

NOTE This feature will not work for all printers due to differences in printer resolution.

Figure 4-2 Printing Two Measurements

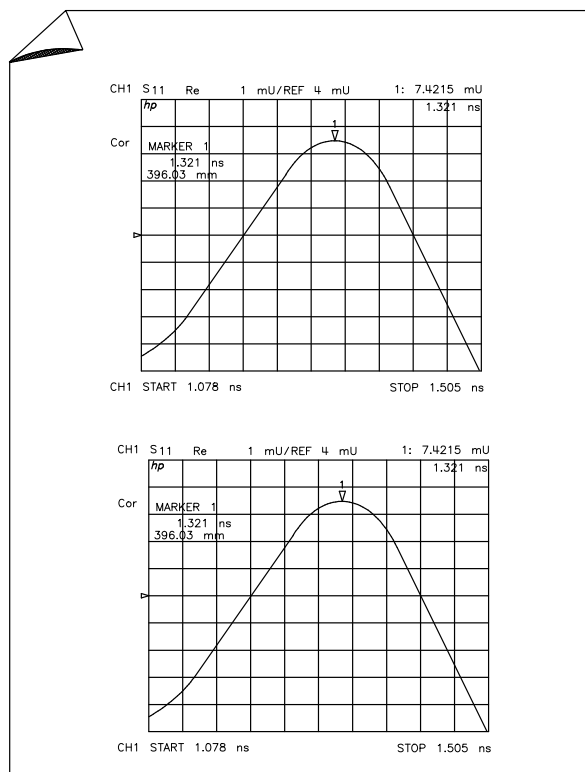

pg6148d

Configuring a Plot Function

All copy configuration settings are stored in non-volatile memory. Therefore, they are not affected if you press **Preset** or switch off the analyzer power.

Peripheral Interface	Recommended Cables
Parallel	92284A
GPIB	10833A/33B/33D
Serial	24542G

1. Connect the peripheral to the interface port using the recommended cable from the following list.

Figure 4-3 Peripheral Connections to the Analyzer

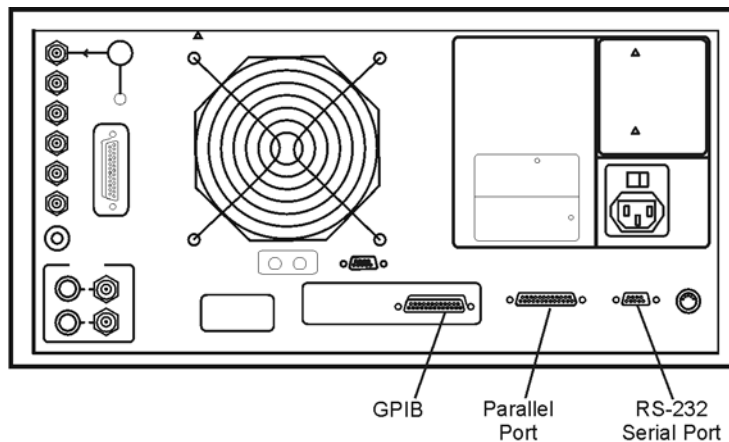

If You Are Plotting to an HPGL/2 Compatible Printer

2. Press **Local** **SET ADDRESSES** **PLTR PORT** and then press **PLTR TYPE []** until HPGL PRT appears.

Information regarding a printer compatibility guide (an up-to-date list of printers that are compatible with the network analyzer) is available in "Printing or Plotting Your Measurement Results" on page 4-3.

3. Configure the analyzer for one of the following printer interfaces:

- Choose **PRNTR PORT GPIB** if your printer has an GPIB interface, and then configure the print function as follows:
 - a. Enter the GPIB address of the printer (default is 01), followed by **(x1)**.
 - b. Press **(Local)** and **SYSTEM CONTROLLER** if there is no external controller connected to the GPIB bus.
 - c. Press **(Local)** and **USE PASS CONTROL** if there is an external controller connected to the GPIB bus.
- Choose **PARALLEL** if your printer has a parallel (Centronics) interface, and then configure the print function as follows:

Press **(Local)** and then select the parallel port interface function by pressing **PARALLEL** until the correct function appears.

 - If you choose **PARALLEL [COPY]**, the parallel port is dedicated for normal copy device use (printers or plotters).
 - If you choose **PARALLEL [GPIO]**, the parallel port is dedicated for general purpose I/O, and cannot be used for printing or plotting.
- Choose **SERIAL** if your printer has a serial (RS-232) interface, and then configure the print function as follows:
 - a. Press **PRINTER BAUD RATE** and enter the printer's baud rate, followed by **(x1)**.
 - b. To select the transmission control method that is compatible with your printer, press **XMIT CNTRL** (transmit control - handshaking protocol) until the correct method appears.
 - If you choose **Xon-Xoff**, the handshake method allows the printer to control the data exchange by transmitting control characters to the network analyzer.
 - If you choose **DTR-DSR**, the handshake method allows the printer to control the data exchange by setting the electrical voltage on one line of the RS-232 serial cable.

NOTE Because the **DTR-DSR** handshake takes place in the hardware rather than the firmware or software, it is the fastest transmission control method.

4. Press **(Local)** **SET ADDRESSES** **PLOTTER PORT** and then **PLTR TYPE** until **PLTR TYPE [HPGL PRT]** appears.

If You Are Plotting to a Pen Plotter

1. Press **(Local)** **SET ADDRESSES** **PLOTTER PORT** and then **PLTR TYPE** until **PLTR TYPE [PLOTTER]** appears.

2. Configure the analyzer for one of the following plotter interfaces:

- Choose **PLTR PORT GPIB** if your plotter has a GPIB interface, and then configure the plot function as follows:
 - a. Enter the GPIB address of the plotter (default is 05), followed by **(x1)**.
 - b. Press **(Local)** and **SYSTEM CONTROLLER** if there is no external controller connected to the GPIB bus.
 - c. Press **(Local)** and **USE PASS CONTROL** if there is an external controller connected to the GPIB bus.
- Choose **PARALLEL** if your plotter has a parallel (Centronics) interface, and then configure the plot function as follows:
 - Press **(Local)** and then select the parallel port interface function by pressing **PARALLEL** until the correct function appears.
 - If you choose **PARALLEL [COPY]**, the parallel port is dedicated for normal copy device use (printers or plotters).
 - If you choose **PARALLEL [GPIO]**, the parallel port is dedicated for general purpose I/O, and cannot be used for printing or plotting.
- Choose **SERIAL** if your plotter has a serial (RS-232) interface, and then configure the plot function as follows:
 - a. Press **PLOTTER BAUD RATE** and enter the plotter's baud rate, followed by **(x1)**.
 - b. To select the transmission control method that is compatible with your plotter, press **XMIT CNTRL** (transmit control - handshaking protocol) until the correct method appears.
 - If you choose **Xon-Xoff**, the handshake method allows the plotter to control the data exchange by transmitting control characters to the network analyzer.
 - If you choose **DTR-DSR**, the handshake method allows the plotter to control the data exchange by setting the electrical voltage on one line of the RS-232 serial cable.

NOTE Because the **DTR-DSR** handshake takes place in the hardware rather than the firmware or software, it is the fastest transmission control method.

If You Are Plotting Measurement Results to a Disk Drive

The plot files that you generate from the analyzer, contain the HPGL representation of the measurement display. The files will not contain any setup or formfeed commands.

CAUTION Do not mistake the line switch for the disk eject button when you are removing the disk from the analyzer. If the line switch is mistakenly pushed, the instrument will be turned off, losing all settings and data that have not been saved.

1. Configure the analyzer to plot to disk.

- a. Press **Local** **SET ADDRESSES** **PLOTTER PORT** **DISK**.
- b. Press **Save/Recall** **SELECT DISK** and select the disk drive that you will plot to.
 - Choose **INTERNAL DISK** if you will plot to the analyzer internal disk drive.
 - Choose **EXTERNAL DISK** if you will plot to a disk drive that is external to the analyzer. Then configure the disk drive as follows:
 1. Press **CONFIGURE EXT DISK** **ADDRESS: DISK** and enter the GPIB address to the disk drive (default is 00) followed by **x1**.
 2. Press **Local** **DISK UNIT NUMBER** and enter the drive where your disk is located, followed by **x1**.
 3. If your storage disk is partitioned, press **VOLUME NUMBER** and enter the volume number where you want to store the instrument state file.

2. Press **Copy** **PLOT**.

The analyzer assigns the first available default filename for the displayed directory. For example, the analyzer would assign PLOT00FP for a LIF format (PLOT00.FP for a DOS format) if there were no previous plot files saved to the disk.

Figure 4-4 shows the three parts of the file name that are generated automatically by the analyzer whenever a plot is requested. The two digit sequence number is incremented by one each time a file with a default name is added to the directory.

Figure 4-4 Automatic File Naming Convention for LIF Format

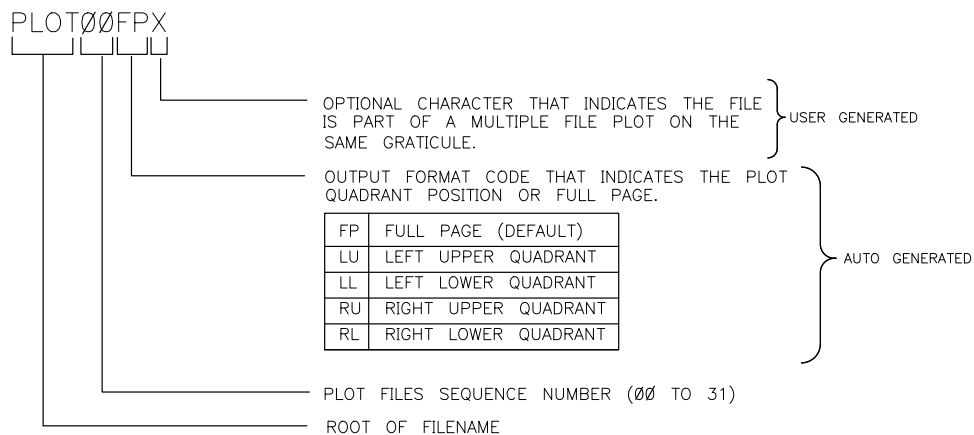

ph646c

To Output the Plot Files

- You can plot the files to a plotter from a personal computer.
- You can output your plot files to an HPGL compatible printer, by following the sequence in ["Outputting Plot Files from a PC to an HPGL Compatible Printer"](#) on page 4-25.
- You can run a program that plots all of the files, with the root filename of PLOT, to an HPGL compatible

Printing, Plotting, and Saving Measurement Results
Configuring a Plot Function

printer. This program is provided on the CD-ROM of example programs that is included in the programmer's guide. However, this program is for use with LIF formatted disks and is written in HP BASIC.

Defining a Plot Function

1. Press **Copy** **DEFINE PLOT**.

Choosing Display Elements

- Choose which of the following measurement display elements that you want to appear on your plot:
 - Choose **PLOT DATA ON** if you want the measurement data trace to appear on your plot.
 - Choose **PLOT MEM ON** if you want the displayed memory trace to appear on your plot.
 - Choose **PLOT GRAT ON** if you want the graticule and the reference line to appear on your plot.
 - Choose **PLOT TEXT ON** if you want all of the displayed text to appear on your plot. (This does not include the marker values or softkey labels.)
 - Choose **PLOT MKR ON** if you want the displayed markers, and marker values, to appear on your plot.

Figure 4-5 Plot Components Available through Definition

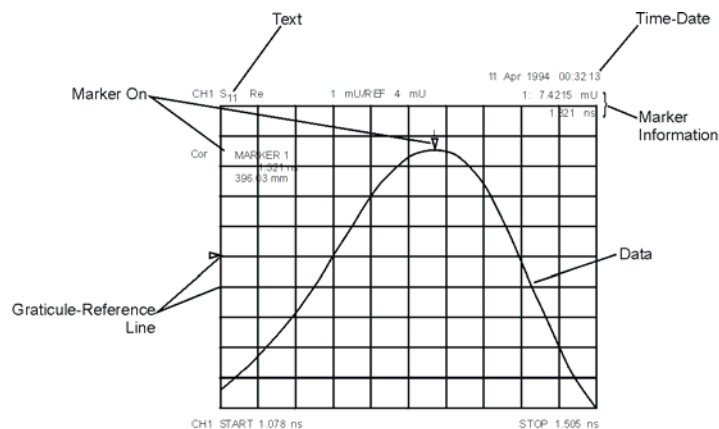

pa5167e

Selecting Auto-Feed

- Press **AUTO-FEED** until the correct choice is highlighted.
 - Choose **AUTO-FEED ON** if you want a "page eject" sent to the plotter or HPGL compatible printer after each time you press **PLOT**.
 - Choose **AUTO-FEED OFF** if you want multiple plots on the same sheet of paper.

NOTE The peripheral ignores **AUTO-FEED ON** when you are plotting to a quadrant.

Selecting Pen Numbers and Colors

- Press **MORE** and select the plot element where you want to change the pen number. For example, press **PEN NUM DATA** and then modify the pen number. The pen number selects the color if you are plotting to an HPGL/2 compatible color printer.

Press **(x1)** after each modification.

NOTE The following color assignments are valid for HPGL/2 compatible color printers only. When using word processor or graphics presentation programs, different colors may be assigned to the pen numbers.

Table 4-2 Default Pen Numbers and Corresponding Colors

Pen Number	Color	Pen Number	Color
0	white	4	yellow
1	cyan	5	green
2	magenta	6	red
3	blue	7	black

Table 4-3 Default Pen Numbers for Plot Elements

Corresponding Key	Plot Element	Pen Numbers	
		Channel 1	Channel 2
PEN NUM DATA	Measurement Data Trace	2	3
PEN NUM MEMORY	Displayed Memory Trace	5	6
PEN NUM GRATICULE	Graticule and Reference Line	1	1
PEN NUM TEXT	Displayed Text	7	7
PEN NUM MARKER	Displayed Markers and Values	7	7

NOTE You can set all the pen numbers to black for a plot in black and white.
 You must define the pen numbers separately for each measurement channel (channel 1/3 and channel 2/4).

Selecting Line Types

- Press **MORE** and select each plot element line type that you want to modify.
 - Select **LINE TYPE DATA** to modify the line type for the data trace. Then enter the new line type

(see Figure 4-6), followed by **(x1)**.

- Select **LINE TYPE MEMORY** to modify the line type for the memory trace. Then enter the new line type (see Figure 4-6), followed by **(x1)**.

Table 4-4 Default Line Types for Plot Elements

Plot Elements	Channel 1 Line Type Numbers	Channel 2 Line Type Numbers
Data Trace	7	7
Memory Trace	7	7

Figure 4-6 Line Types Available

- 0- Specifies dots only at the points that are plotted.
- 1-
- 2- — — — — —
- 3- — — — — —
- 4-
- 5- — — — — —
- 6- — — — — —
- 7- — — — — —

pg6135d

NOTE You must define the line types for each measurement channel (channel 1/3 and channel 2/4).

Choosing Scale

- Press **SCALE PLOT** until the selection appears that you want.
 - Choose **SCALE PLOT [FULL]** if you want the normal scale selection for plotting. This includes space for all display annotations such as marker values and stimulus values. The entire analyzer display fits within the defined boundaries of P1 and P2 on the plotter, while maintaining the exact same aspect ratio as the display.
 - Choose **SCALE PLOT [GRAT]** if you want the outer limits of the graticule to correspond to the defined P1 and P2 scaling point on the plotter. (Intended for plotting on preprinted rectangular or polar forms.)

Figure 4-7 Locations of P1 and P2 in **SCALE PLOT [GRAT]** Mode

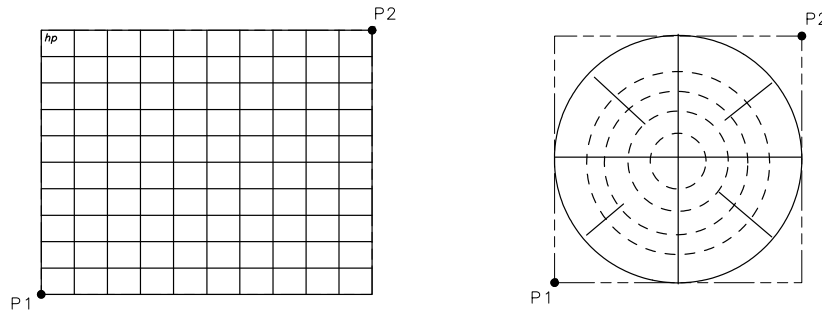

pg6157d

Choosing Plot Speed

- Press **PLOT SPEED** until the plot speed appears that you want.
 - Choose **PLOT SPEED [FAST]** for normal plotting.
 - Choose **PLOT SPEED [SLOW]** for plotting directly on transparencies. (The slower speed provides a more consistent line width.)

To Reset the Plotting Parameters to Default Values

Press **Copy** **DEFINE PLOT** **MORE** **MORE** **YES**.

Table 4-5 Plotting Parameter Default Values

Plotting Parameter	Default Value	Plotting Parameter	Default Value
Select Quadrant	Full page	Plot Scale	Full
Auto Feed	ON	Plot Speed	Fast
Define Plot	All plot elements on	Line Type	7 (solid line)
Pen Numbers: Channel 1 and 3		Pen Numbers: Channel 2 and 4	
Data	2	Data	3
Memory	5	Memory	6
Graticule	1	Graticule	1
Text	7	Text	7
Marker	7	Marker	7

Plotting One Measurement Per Page Using a Pen Plotter

1. Configure and define the plot, as explained in "Configuring a Plot Function" on page 4-10 and "Defining a Plot Function" on page 4-15.
2. Press **Copy** **PLOT** .
 - If you defined the **AUTO-FEED OFF** , press **PLOTTER FORM FEED** after the message COPY OUTPUT COMPLETED appears.

Plotting Multiple Measurements Per Page Using a Pen Plotter

1. Configure and define the plot, as explained in "Configuring a Plot Function" on page 4-10 and "Defining a Plot Function" on page 4-15.
2. Press **Copy** **SEL QUAD []**.
3. Choose the quadrant where you want your displayed measurement to appear on the hardcopy. The following quadrants are available:

- LEFT UPPER**
- LEFT LOWER**
- RIGHT UPPER**
- RIGHT LOWER**

The selected quadrant will appear in the brackets under **SEL QUAD []**.

Figure 4-8 Plot Quadrants

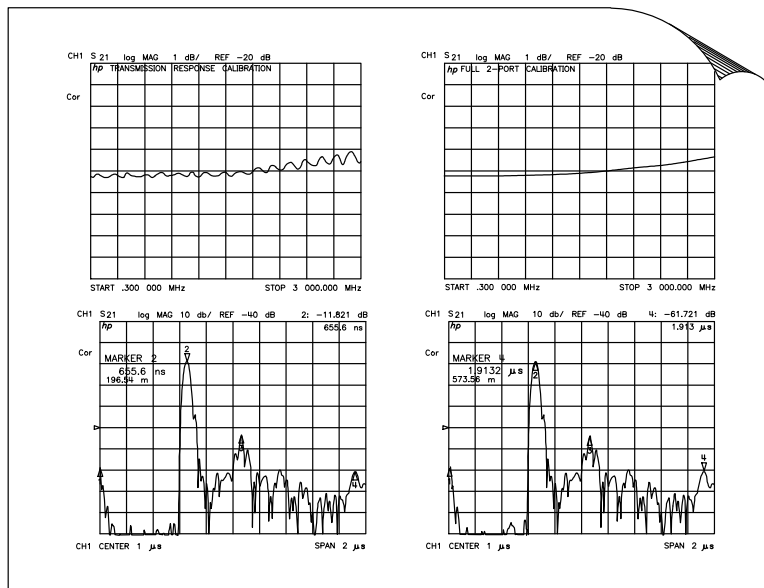

pg65e

4. Press **PLOT**.
5. Make the next measurement that you want to see on your hardcopy.
6. Press **Copy** and choose another quadrant where you want to place the displayed measurement.
7. Repeat the previous three steps until you have captured the results of up to four measurements.

If You Are Plotting to an HPGL Compatible Printer

1. Configure and define the plot, as explained in "Configuring a Plot Function" on page 4-10 and "Defining a Plot Function" on page 4-15.
2. Press **(Copy) PLOT PLOTTER FORM FEED** to print the data the printer has received.

NOTE Use test sequencing to automatically plot all four S-parameters.

1. Set all measurement parameters.
2. Perform a full 2-port calibration.
3. Enter the test sequence:

(Seq) NEW SEQ/MODIFY SEQ SEQUENCE 1 SEQ1

(Meas) Refl: FWD S11 (A/R)

(Copy) SEL QUAD [] SELECT DISK LEFT UPPER PLOT

(Meas) Trans: FWD S21 (B/R)

(Copy) SEL QUAD [] LEFT LOWER PLOT

(Meas) Refl: REV S22 (B/R)

(Copy) SEL QUAD [] RIGHT UPPER PLOT

(Meas) Trans: REV S12 (B/R)

(Copy) SEL QUAD [] RIGHT LOWER PLOT

(Seq) DONE SEQ MODIFY

4. Run the test sequence by pressing:

(Seq) DO SEQUENCE SEQUENCE 1 SEQ1

To View Plot Files on a PC

Plot files can be viewed and manipulated on a PC using a word processor or graphics presentation program. Plot files contain a text stream of HPGL (Hewlett-Packard Graphics Language) commands. In order to import a plot file into an application, that application *must* have an import filter for HPGL (often called HGL). Two such applications from the Lotus® suite of products are the word processor "Ami Pro" and the graphics presentation package "Freelance Graphics." Additionally, a utility is available to convert plot files to PCX format so they can be used in additional PC applications.

NOTE Lotus applications are not supported by Hewlett-Packard. The following procedures are provided for informational use only. Other applications or other versions of the same application may function differently.

When viewed in such programs, the color and font size of the plot may vary from the output of an HPGL/2 compatible color printer. The following table shows the differences between the color assignments of HPGL/2 compatible printers and Lotus applications. Also refer to "[Selecting Pen Numbers and Colors](#)" on page 4-16.

Table 4-6 Color Assignment Differences between HPGL/2-Compatible Printers and Lotus Applications

HPGL/2 Printer		Lotus Applications	
Pen Number	Color	Pen Number	Color
0	white	N/A	N/A
1	cyan (aqua)	1	black
2	magenta (red-violet)	2	red
3	blue	3	green
4	yellow	4	yellow
5	green	5	blue
6	red	6	red-violet (magenta)
7	black	7	aqua (cyan)

To modify the color or font size, consult the documentation for the particular application being used.

NOTE Plot files may also be saved to a floppy disk as a JPEG file and used on a personal computer. Refer to "[Saving in Graphical \(JPEG\) Form](#)" on page 4-46.

Using Ami Pro

To view plot files in Ami Pro, perform the following steps:

1. From the FILE pull-down menu, select IMPORT PICTURE.

2. In the dialog box, change the File Type selection to HPGL. This automatically changes the file suffix in the filename box to *.PLT.

NOTE The network analyzer does not use the suffix *.PLT, so you may want to change the filename filter to *.* or some other pattern that will allow you to locate the files you wish to import.

3. Click OK to import the file.
4. The next dialog box allows you to select paper type, rotation (landscape or portrait), and pen colors. You will probably need to change pen colors.

NOTE The network analyzer uses pen 7 for text. The default color in Ami Pro for pen 7 is aqua, which is not very readable against the typical white background. You may want to change pen 7 to black.

5. After all selections have been made, the file is imported and rendered in a small graphics frame which can be sized to the page by grabbing one of the nodes and stretching the box as required.
 - You will notice that the annotation around the display is not optimum, as the Ami Pro filter does not accurately import the HPGL command to render text.

Using Freelance

To view plot files in Freelance, perform the following steps:

1. From the FILE pull-down menu, select IMPORT.
2. Set the file type in the dialog box to HGL.

NOTE The network analyzer does not use the suffix *.HGL, so you may want to change the filename filter to *.* or some other pattern that will allow you to locate the files you wish to import.

3. Click OK to import the file.
 - You will notice that when the trace is displayed, the text annotation will be illegible. You can easily fix this with the following steps:
 - a. From the TEXT pull-down menu, select FONT.
 - b. Select the type face and size. (Fourteen point text is a good place to start.)
 - c. Click OK to resize the font.

To change the font color, just do it immediately after you resize the font using the same dialog box.

Converting HPGL Files for Use with Other PC Applications

A utility can convert hpgl (or .fp) files to other PC applications. This utility, named hp2xx, is available to be downloaded without charge (on donation basis only) from Free Software Foundation. You may download this file using the information available on the following Web site: <ftp://ots.external.hp.com/rfmw/lou/>

To convert HPGL files to be used with other PC applications.

Outputting Plot Files from a PC to a Plotter

1. Using the instructions on the Free Software Foundation website, FTP the hp2xx file and save it on a floppy disk as "hp2xx.exe".
2. Create the following batch file and save it on the same floppy disk as "hpglconv.bat".

The batch file consists of the following two lines:

```
@ echo off
A:\hp2xx.exe -m pcx %1
```

(where "A" is the disk drive where the floppy disk is installed.)

3. Insert the floppy disk (with the two files already installed) into your analyzer.
4. Make sure the measurement that you want to convert is displayed on the analyzer display.
5. Create an HPGL file of the measurement and save it to the floppy disk by pressing **Local**
SET ADDRESSES **PLOTTER PORT** **DISK** **Copy** **PLOT**.
6. Remove the floppy disk from the analyzer and insert it back into the PC.
7. Using Explorer or File Manager, click and drag the icon of the newly-created hpgl file onto the icon of the hpglconv.bat file. This process creates a PCX format file from the hpgl file.

NOTE This conversion method has been used to convert many measurement displays. However, this conversion utility is not supported by Agilent Technologies.

Outputting Plot Files from a PC to a Plotter

1. Connect the plotter to an output port of the computer (for example, COM1).
2. If using the COM1 port, output the file to the plotter by using the following command:

```
C:> TYPE PLOT00.FP > COM1
```

Outputting Plot Files from a PC to an HPGL Compatible Printer

To output the plot files to an HPGL compatible printer, you can use the HPGL initialization sequence linked in a series as follows:

- Step 1. Store the HPGL initialization sequence in a file named `hpglinit`.
- Step 2. Store the exit HPGL mode and form feed sequence in a file named `exithpgl`.
- Step 3. Send the HPGL initialization sequence to the printer.
- Step 4. Send the plot file to the printer.
- Step 5. Send the exit HPGL mode and form feed sequence to the printer.

Step 1. Store the HPGL initialization sequence.

1. Create a test file by typing in each character as shown in the left column of [Table 4-7](#). Do not insert spaces or linefeeds. Most editors allow the inclusion of escape sequences.

For example, in the MS-DOS editor (DOS 5.0 or greater), press CNTRL-P (hold down the CTRL key and press P) followed by the ESCape key to create the escape character.

2. Name the file `hpglinit`.

Table 4-7 HPGL Initialization Commands

Command	Remark
<code><esc>E</code>	conditional page eject
<code><esc>&12A</code>	page size 8.5 x 11
<code><esc>&l10</code>	landscape orientation (lower case l, one, capital O)
<code><esc>&a0L</code>	no left margin (a, zero, capital L)
<code><esc>&a400M</code>	no right margin (a, 4, zero, zero, capital M)
<code><esc>&l0E</code>	no top margin (lower case l, zero, capital E)
<code><esc>*c7680x5650Y</code>	frame size 10.66"x 7.847" (720 decipoints/inch)
<code><esc>*p50x50Y</code>	move cursor to anchor point
<code><esc>*c0T</code>	set picture frame anchor point
<code><esc>*r-3U</code>	set CMY palette
<code><esc>%1B</code>	enter HPGL mode; cursor at PCL

NOTE As shown in [Table 4-7](#), the `<esc>` is the symbol used for the escape character, decimal value 27.

Step 2. Store the exit HPGL mode and form feed sequence.

1. Create a test file by typing in each character as shown in the left column of [Table 4-8](#). Do not insert spaces or linefeeds.
2. Name the file `exithpgl`.

Table 4-8 HPGL Test File Commands

Command	Remark
<code><esc>%0A</code>	exit HPGL mode
<code><esc>E</code>	form feed

Step 3. Send the HPGL initialization sequence to the printer.

Type `print hpglinit` to send the initialization sequence to the printer.

Step 4. Send the plot file to the printer.

Type `print filename` (where `filename` is the name of the HPGL plot file) to send the plot file to the printer.

Step 5. Send the exit HPGL mode and form feed sequence to the printer.

Type `print exithpgl` to send the HPGL mode and form feed sequence to the printer.

Outputting Single Page Plots Using a Printer

You can output plot files to an HPGL compatible printer using the DOS command line and the files created in the previous steps. This example assumes that the escape sequence files and the plot files are in the current directory and the selected printer port is PRN.

Command	Remarks
<code>C:></code>	<code>type hpglinit > PRN</code>
<code>C:></code>	<code>type PLOT00.FP > PRN</code>
<code>C:></code>	<code>type exithpgl > PRN</code>

Outputting Multiple Plots to a Single Page Using a Printer

Refer to ["Plotting Multiple Measurements Per Page Using a Pen Plotter" on page 4-20](#) for the naming conventions for plot files that you want printed on the same page. You can use the following batch file to automate the plot file printing. In this example, the batch file is saved as "do_plot.bat." However, before running this batch file, you must first create the `hpglinit` file and the `exithpgl` file described in ["Outputting Plot Files from a PC to an HPGL Compatible Printer" on page 4-25](#).

```
rem _____  
rem Name: do_plot  
rem  
rem Description:  
rem  
rem output HPGL initialization sequence to a file:spooler  
rem append all the requested plot files to the spooler  
rem append the formfeed sequence to the spooler  
rem copy the file to the printer  
rem  
rem (This routine uses COPY instead of PRINT because COPY  
rem will not return until the action is completed. PRINT  
rem will queue the file so the subsequent DEL will likely  
rem generate an error. COPY avoids this.)  
rem _____  
  
echo off  
type hpglinit > spooler  
for %%i in (%1) do type %%i >> spooler  
type exithpgl >> spooler  
copy spooler LPT1  
del spooler  
echo on
```

For example, you have the following list of files to plot:

```
PLOT00.LL  
PLOT00.LU  
PLOT00.RL  
PLOT00.RU
```

You would invoke the batch print as follows:

```
C:> do_plot PLOT00.*
```

Plotting Multiple Measurements Per Page from Disk

The following procedures show you how to store plot files on a LIF formatted disk. A naming convention is used so you can later run an HP BASIC program on an external controller that will output the files to the following peripherals:

- a plotter with auto-feed capability, such as the HP 7550B
- an HP-GL/2 compatible printer, such as the LaserJet 4 series (monochrome) or the DeskJet 1200C or DeskJet 1600C (color)

The program is provided on the CD-ROM of example programs that is included in the programmer's guide. The file naming convention allows the program to initiate the following:

- to initialize the printer for HP-GL/2 at the beginning of a page
- to plot multiple plot files on the same page
- to send a page eject (form feed) to the hardcopy device, when all plots to the same page have been completed

The plot file name is made up of four parts; the first three are generated automatically by the analyzer whenever a plot is requested. The two digit sequence number is incremented by one each time a file with a default name is added to the directory.

Figure 4-9 Plot Filename Convention

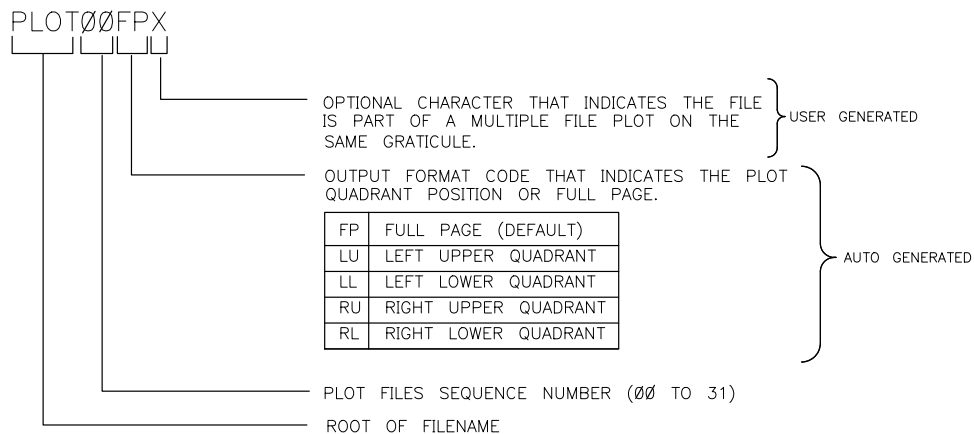

ph646c

To Plot Multiple Measurements on a Full Page

You may want to plot various files to the same page, for example, to show measurement data traces for different input settings, or parameters, on the same graticule.

1. Define the plot, as explained in "Defining a Plot Function" on page 4-15.
2. Press **(Copy) PLOT DEFINE PRINT**. The analyzer assigns the first available default filename for the displayed directory. For example, the analyzer would assign PLOT00FP if there were no previous plot files on the disk.
3. Press **(Save/Recall)** and turn the front panel knob to highlight the name of the file that you just saved.
4. Press **FILE UTILITIES RENAME FILE** and turn the front panel knob to place the ↑ pointer to the A character.
5. Press **SELECT LETTER DONE**.
6. Define the next measurement plot that you will be saving to disk.
 For example, you may want only the data trace to appear on the second plot for measurement comparison. In this case, you would press **(Copy) DEFINE PLOT** and choose
PLOT DATA ON PLOT MEM OFF PLOT GRAT OFF PLOT TEXT OFF PLOT MKR OFF.
7. Press **(Copy) PLOT**. The analyzer will assign PLOT00FP because you renamed the last file saved.
8. Press **(Save/Recall)** and turn the front panel knob to highlight the name of the file that you just saved.
9. Press **FILE UTILITIES RENAME FILE** and turn the front panel knob to place the ↑ pointer to the B character.
10. Press **SELECT LETTER DONE**.
11. Continue defining plots and renaming the saved file until you have saved all the data that you want to put on the same page. Renaming the files as shown allows you to use the provided program, that organizes and plots the files, according to the file naming convention.

Plot File	Recognized Filename
First File Saved	PLOT00FPA
Second File Saved	PLOT00FPB
Third File Saved	PLOT00FPC
Fourth File Saved	PLOT00FPD

Figure 4-10 shows plots for both the frequency and time domain responses of the same device.

Figure 4-10 Plotting Two Files on the Same Page

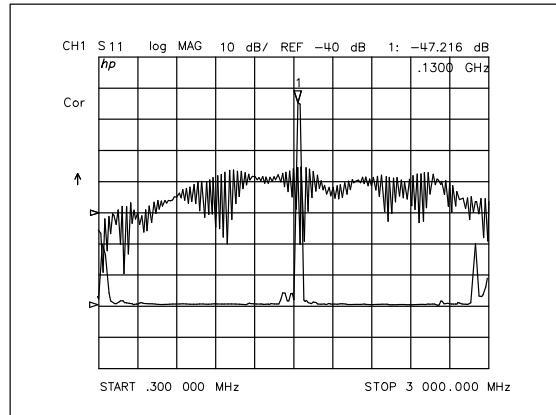

ph647c

To Plot Measurements in Page Quadrants

1. Define the plot, as explained in "Defining a Plot Function" on page 4-15.
2. Press **Copy** **SEL QUAD []**.
3. Choose the quadrant where you want your displayed measurement to appear on the hardcopy. The selected quadrant appears in the brackets under **SEL QUAD []**.

Figure 4-11 Plot Quadrants

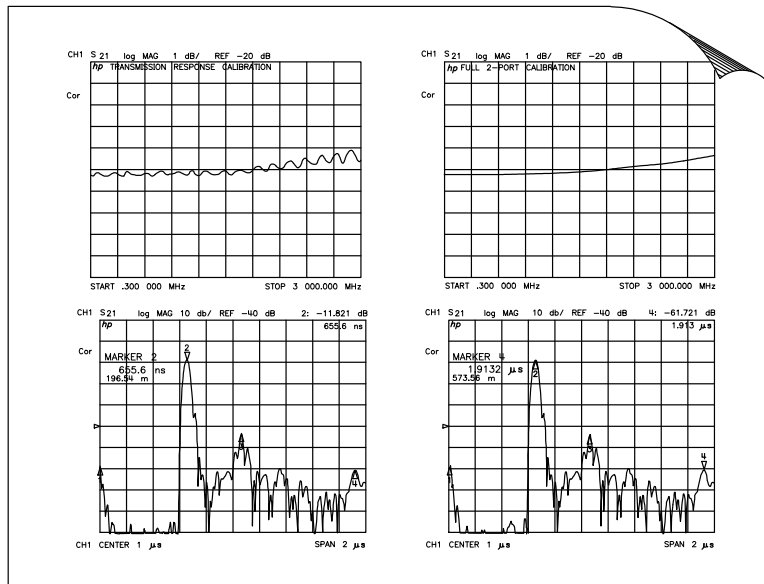

pg65e

4. Press **PLOT**. The analyzer assigns the first available default filename for the selected quadrant. For

example, the analyzer would assign PLOT01LU if there were no other left-upper quadrant plots on the disk.

5. Make the next measurement that you want to see on your hardcopy.
6. Repeat this procedure for the remaining plot files that you want to see as quadrants on a page. If you want to see what quadrants you have already saved, press to view the directory.

Titling the Displayed Measurement

1. Press **Display** **MORE** **TITLE** to access the title menu.
2. Press **ERASE TITLE** and enter the title you want for your measurement display.
 - If you have a DIN keyboard attached to the analyzer, type the title you want from the keyboard. Then press **ENTER** to enter the title into the analyzer. You can enter a title that has a maximum of 50 characters. (For more information on using a keyboard with the analyzer, refer to the “Options and Accessories” chapter of the reference guide.)
 - If you do not have a DIN keyboard attached to the analyzer, enter the title from the analyzer front panel.
 - a. Turn the front panel knob to move the arrow pointer to the first character of the title.
 - b. Press **SELECT LETTER**.
 - c. Repeat the previous two steps to enter the rest of the characters in your title. You can enter a title that has a maximum of 50 characters.
 - d. Press **DONE** to complete the title entry.

Figure 4-12 Example of a Display Title

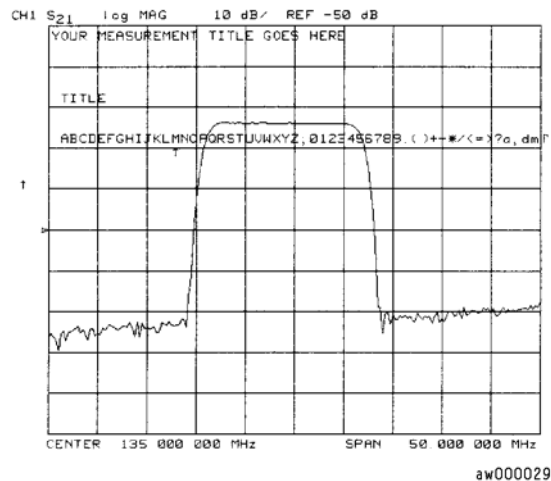

CAUTION The **NEWLINE** and **FORMFEED** keys are not intended for creating display titles. Those keys are for creating commands to send to peripherals during a sequence program.

Configuring the Analyzer to Produce a Time Stamp

You can set a clock, and then activate it, if you want the time and date to appear on your hardcopies.

1. Press **(System)** **SET CLOCK**.
2. Press **SET YEAR** and enter the current year, followed by **(x1)**.
3. Press **SET MONTH** and enter the current month of the year, followed by **(x1)**.
4. Press **SET DAY** and enter the current day of the month, followed by **(x1)**.
5. Press **SET HOUR** and enter the current hour of the day (0-23), followed by **(x1)**.
6. Press **SET MINUTES** and enter the next immediate minute, followed by **(x1)**.
7. Press **ROUND SECONDS** when the current time is exactly as you have set it.
8. Press **TIME STAMP** until **TIME STAMP ON** appears on the softkey label.

Aborting a Print or Plot Process

1. Press the **(Local)** key to stop all data transfer.
2. If your peripheral is not responding, press **(Local)** again or reset the peripheral.

Printing or Plotting the List Values or Operating Parameters

Press **Copy** **LIST** and select the information that you want to appear on your hardcopy.

- Choose **LIST VALUES** if you want a tabular listing of the measured data points, and their current values, to appear on your hardcopy. This list will also include the limit test information, if you have the limits function activated.
- Choose **OP PARMS (MKRS etc)** if you want a tabular listing of the parameters for both measurement channels to appear on your hardcopy. The parameters include: operating parameters, marker parameters, and system parameters that relate to the control of peripheral devices.

If You Want a Single Page of Values

1. Choose **PRINT MONOCHROME** for a printer or **PLOT** for a plotter peripheral, to create a hardcopy of the displayed page of listed values.
2. Press **NEXT PAGE** to display the next page of listed values. Press **PREVIOUS PAGE** to display the previous page of listed values. Or, you can press **NEXT PAGE** or **PREVIOUS PAGE** repeatedly to display a particular page of listed values that you want to appear on your hardcopy. Then repeat the previous step to create the hardcopy.
3. Repeat the previous two steps until you have created hardcopies for all the desired pages of listed values.

If you are printing the list of measurement data points, each page contains 30 lines of data. The number of pages is determined by the number of measurement points that you have selected.

If You Want the Entire List of Values

Choose **PRINT ALL** to print all pages of the listed values.

NOTE If you are printing the list of operating parameters, only the first four pages are printed. The fifth page, system parameters, is printed by displaying that page and then pressing **PRINT**.

Solving Problems with Printing or Plotting

If you encounter a problem when you are printing or plotting, check the following list for possible causes:

- Look in the analyzer display message area. The analyzer may show a message that will identify the problem. Refer to the "Error Messages" chapter of the reference guide if a message appears.
- If necessary, refer to the peripheral configuration procedures in this chapter to check that you have done the following:
 - connected an interface cable between the peripheral and the analyzer
 - connected the peripheral to ac power
 - switched on the power
 - switched the peripheral on line
 - selected the correct printer or plotter type
- If you are using a laser printer for plotting, and the printer is outputting partial plots, the printer may require more memory or the page protection activated.

NOTE Consult your printer documentation for information on upgrading memory and how to activate page protection.

- Make sure that the analyzer address setting for the peripheral corresponds to the actual GPIB address of the peripheral. The procedure is explained earlier in this chapter.
- Make sure that the analyzer is in system controller mode, by pressing **Local** **SYSTEM CONTROLLER**, if the analyzer is not connected to an external controller. Otherwise, the analyzer must be in the pass control mode.
- Substitute the interface cable.
- Substitute a different printer or plotter.

Saving and Recalling Instrument States

Places Where You Can Save

- analyzer internal memory
- floppy disk using the analyzer's internal disk drive
- floppy disk using an external disk drive
- IBM compatible personal computer using GPIB mnemonics

What You Can Save to the Analyzer's Internal Memory

The number of registers that the analyzer allows you to save depends on the size of associated error-correction sets, and memory traces. However, the maximum number of registers that can be saved to internal memory is 31. Refer to the "Preset State and Memory Allocation" chapter of the reference guide for further information.

You can save instrument states in the analyzer internal memory, along with the following list of analyzer settings. The default file names are REG<01-31>.

- error-corrections on channels 1 and 2
- displayed memory trace
- print/plot definitions
- measurement setup
 - frequency range
 - number of points
 - sweep time
 - output power
 - sweep type
 - measurement parameter

NOTE When the ac line power is switched off, the internal non-volatile memory is retained by a battery. Refer to "Specifications and Characteristics" in the reference guide for data retention times.

What You Can Save to a Floppy Disk

You can save an instrument state and measurement results to a disk. The default file names are FILEn, where n gets incremented by one each time a file with a default name is added to the directory. The default file names for data-only files are DATAyDz (DATAy.Dz for DOS), where y is incremented by one each time a file with a default name is added to the directory. The z is the channel where the measurement was made. When you save a file to disk, you can choose to save some or all of the following:

- all settings listed for internal memory
- active error-correction for the active channel only
- displayed measurement data trace
- displayed user graphics
- data only
- HPGL plots

What You Can Save to a Computer

Instrument states can be saved to and recalled from an external computer (system controller) using GPIB mnemonics. For more information about the specific analyzer settings that can be saved, refer to the output commands located in the "Command Reference" chapter of the programmer's guide. For an example program, refer to the "Programming Examples" chapter of the programmer's guide.

Saving an Instrument State

1. Press **(Save/Recall) SELECT DISK** and select one of the storage devices:
 - INTERNAL MEMORY**
 - INTERNAL DISK**
 - EXTERNAL DISK** connect an external disk drive to the analyzer's GPIB connector, and configure as follows:
 - a. Connect an external disk drive to the analyzer's GPIB connector, and configure as follows:
 - b. Press **(Local) DISK UNIT NUMBER** and enter the drive where your disk is located, followed by **(x1)**.
 - c. If your storage disk is partitioned, press **VOLUME NUMBER** and enter the volume number where you want to store the instrument state file.
 - d. Press **SET ADDRESSES ADDRESS: DISK**.
 - e. Enter the GPIB address of the peripheral, if the default address is incorrect (default = 00). Follow the entry by pressing **(x1)**.
 - f. Press **(Local)** and select one of the following:
 - **SYSTEM CONTROLLER** allows the analyzer to control peripherals directly.
 - **TALKER/LISTENER** allows the computer controller to be involved in all peripheral access operations.
 - **USE PASS CONTROL** allows you to control the analyzer over GPIB and also allows the analyzer to take or pass control.
2. Press **(Save/Recall) SAVE STATE**.

The analyzer saves the state in the next available register, if you are saving to internal memory, or saves the state to disk. Although one file is shown to represent an instrument state on the analyzer display, each instrument state is composed of numerous files (which can be viewed on a PC).

NOTE If you have saved enough files that you have used all the default names (FILE00 – FILE31 for disk files, or REG1 – REG31 for memory files), you must do one of the following to save more states:

- use another disk
 - rename an existing file to make a default name available
 - re-save a file/register
 - delete an existing file/register
-

Saving Measurement Results

Instrument states combined with measurements results can only be saved to disk. Files that contain data-only, and the various save options available under the **DEFINE DISK-SAVE** key, are also only valid for disk saves.

The analyzer stores data in arrays along the processing flow of numerical data, from IF detection to display. These arrays are points in the flow path where data is accessible, usually via GPIB. You can choose from three different arrays which vary in modification flexibility when they are recalled.

- raw data
- data (raw data with error-correction applied) if correction is on; otherwise, raw data
- format (data processed to the display format)

If you choose to save the raw data array, you will have the most flexibility in modifying the recalled measurement (including the ability to view all four S-parameters). This is because the raw data array has the least amount of processing associated with it. Conversely, if you choose to save the format array, your modification of the recalled measurement will be limited by all the processes that are associated with that measurement result. However, the format array is appropriate if you want to retrieve data traces that look like the currently displayed data.

Define Save	Modification Flexibility During Recall
Raw Data Array	Most
Data Array	Medium
Format Array	Least

You can also save data-only. This is saved to disk with default file names

DATA00D1 to DATA31D1 for channel 1
DATA00D2 to DATA31D2 for channel 2
DATA00D3 to DATA31D3 for channel 3
DATA00D4 to DATA31D4 for channel 4

However, these files are not instrument states and cannot be recalled.

Figure 4-13 Data Processing Flow Diagram

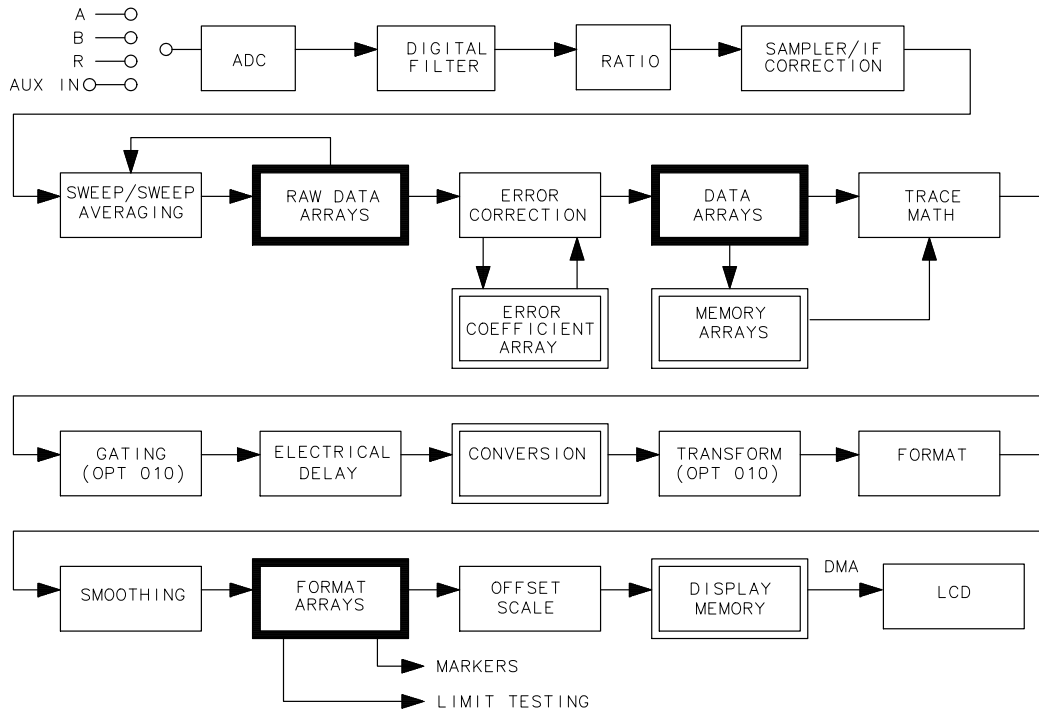

pb6101d

NOTE If the analyzer has an active two-port measurement calibration, all four S-parameters will be saved with the measurement results. All four S-parameters may be viewed if the raw data array has been saved.

1. If you want to title the displayed measurement, refer to ["Titrating the Displayed Measurement"](#) on page 4-32.
2. Press **Save/Recall** **SELECT DISK**.
3. Choose one of the following disk drives:
 - **INTERNAL DISK**
 - **EXTERNAL DISK** (If necessary, refer to the external disk setup procedure in ["Saving an Instrument State"](#) on page 4-38.)
4. Press **Save/Recall** **DEFINE DISK-SAVE**.
5. Define the save by selecting from the following choices:
 - DATA ARRAY ON**
 - RAW ARRAY ON**
 - FORMAT ARY ON**

If you select **DATA ARRAY ON**, **RAW ARRAY ON**, or **FORMAT ARY ON**, the data is stored to disk in IEEE-64 bit real format (for LIF disks), and 32 bit PC format for DOS disks. This makes the DOS data files half the size of the LIF files.

NOTE Selecting **DATA ARRAY ON** may also store data to disk in the S2P ASCII data format. See ["ASCII Data Formats" on page 4-41](#).

GRAPHICS ON

If you select **GRAPHICS ON**, the user graphics area is saved. (Refer to the programmer's guide for information on using display graphics.) The measurement display is not saved with this selection. (Refer to ["If You Are Plotting Measurement Results to a Disk Drive" on page 4-12](#) to plot measurement displays to disk.)

DATA ONLY ON

If **DATA ONLY ON** data array is saved along with any other selected array, the instrument state is *not* saved, and therefore, *cannot be recalled*.

6. Choose the type of format you want:

- Choose **SAVE USING BINARY** for all applications except CITIfile, S2P, or CAE applications.
- Choose **SAVE USING ASCII** for CITIfile, S2P, and CAE applications or when you want to import the information into a spread sheet using comma-separated values (CSV) format.

7. Press **RETURN** **SAVE STATE**.

ASCII Data Formats

CITIfile

CITIfile (Common Instrumentation Transfer and Interchange file) is an ASCII data format that is useful when exchanging data between different computers and instruments. CITIfiles are always saved when the ASCII format has been selected as shown:

Save/Recall

DEFINE DISK-SAVE

Select one of the following choices:

- **DATA ARRAY ON**
- **DATA ONLY ON**
- **RAW ARRAY ON**
- **FORMAT ARY ON**
- SAVE USING ASCII**
- RETURN**
- SAVE STATE**

If **DATA ARRAY ON**, or **DATA ONLY ON**, or **FORMAT ARY ON** is selected, a CITIfile is saved

Saving Measurement Results

for each displayed channel with the suffix letter "D", or "F", followed by a number. The number following "D" and "F" files is the channel number. When **RAW ARRAY ON** is selected, an "r1" file is saved for channel 1/channel 3, and an "r5" file is saved for channel 2/channel 4. For more information on the CITIFile data format as well as a list of CITIFile keywords, refer to the "Understanding the CITIFile Data Format" chapter in the reference guide.

S2P Data Format

This format creates component data files that describe frequency dependent linear network parameters for 2 port components. These files are assigned a file name with the suffix "S" and are only output (that is, they cannot be read in by the analyzers).

Up to two S2P files are saved: S1 for channel 1, and S2 for channel 2. S2P files are not stored for channel 3 or channel 4 because the data would be redundant. Each S2P file contains all four S-parameter data.

An S2P file is only output when the all of following conditions are met:

- a full two-port or TRL two-port correction is turned on
- **DATA ARRAY ON** or **DATA ONLY ON** is selected using **DEFINE DISK SAVE**
- **SAVE USING ASCII** is selected

Error-corrected data CITI files are always saved along with S2P files.

The template for component data files is as follows:

```
! comment line
# <frequency units> <parameter> <format> <Rn>
<data line>
..
<data line>
```

where

!	indicates that all following on this line is a comment
#	indicates that entries following on this line are parameters that are being specified
frequency units	GHz, MHz, kHz, Hz
parameter	S for S-parameters
format	DB for dB magnitude and angle in degrees MA for linear magnitude and angle in degrees RI for real and imaginary pair
Rn	the reference impedance in ohms for the analyzer making the measurement (R 50 or R 75)

The "format" choice is selected by the current selection under the FORMAT menu. To select the DB format, the FORMAT must be LOG MAG. For MA, the FORMAT must be LIN MAG (unlike CITIfile), and all other FORMAT selections will output RI data.

The S2P data will always represent the format array data, including effects of electrical delay and port extensions. A CITIfile will be saved at the same time. To be consistent with previous versions, the CITIfile data saved will represent the DATA array (corrected data) without effects of electrical delay or port extensions.

CAUTION Using the smoothing feature or saving data displayed in time domain format may result in invalid S2P data. Avoid using these functions when saving S2P files.

Here is an S2P example file for an 11 point measurement of a 20 dB attenuator:

```
# HZ S DB R 50
! Network Analyzer HP8753E.0611

50000000 -56.74 15.178 -20.219 -2.0132 -20.15 -1.6658 -36.188 -123.52
250000000 -53.015 1.7331 -20.373 -10.241 -20.377 -10.029 -33.974 -40.215
450000000 -52.094 5.8173 -20.391 -18.555 -20.387 -17.96 -31.287 61.778
650000000 -51.758 8.02 -20.189 -26.18 -20.112 -26.061 -29.427 153.37
850000000 -50.95 11.472 -20.163 -34.743 -20.198 -34.195 -24.719 -137.83
1050000000 -50.235 9.3562 -20.178 -42.682 -20.19 -42.289 -25.102 -81.096
1250000000 -49.883 9.2574 -20.142 -50.854 -20.223 -50.407 -27.582 -25.509
1450000000 -48.477 5.9944 -20.201 -58.917 -20.21 -58.436 -33.828 35.237
1650000000 -48.462 3.5156 -20.161 -67.008 -20.188 -66.587 -44.184 62.912
1850000000 -47.503 1840 -20.15 -74.862 -20.208 -74.616 -36.893 35.384
2050000000 -46.938 -5.6538 -20.167 -83.048 -20.256 -82.874 -30.385 74.001
```

Saving in Textual (CSV) Form

Textual measurement results can be saved in a comma-separated value (CSV) format and imported into a spreadsheet application. Additional information is also saved as a preamble to the measurement results. The saved information includes:

- Network analyzer model number and firmware version
- Date the file was saved
- Type of measurement being done
- Start and stop frequencies
- Sweep time
- Port power
- IF bandwidth
- Channel number
- Number of points
- Format
- The frequency (or time) and the real and imaginary measurement values for each of points measured

1. Press **Save/Recall** **SAVE FILE FORMATS**.
2. Make sure that **TEXT FMT [CSV]** is displayed.
3. Make sure that **FILETYPE: TEXT** is underlined. If it is not underlined, press the softkey so that TEXT is underlined.
4. Insert a 3.5-inch floppy disk in the network analyzer's disk drive.
5. Press **SAVE FILE** to save the display information as text in the CSV format.

The text file may be retrieved from the floppy disk on personal computer and can be imported into an application that accepts text in the comma-separated value format, such as a spreadsheet.

How the Analyzer Names These Files Sequentially

When text files are saved, the analyzer generates the file names automatically in the following format:

txtcss.csv

- where:*
- txt is a constant that indicates that this is a text file,
 - c is the indicator of the channel (1–4) on which the measurement data was taken.
 - ss is a 2-digit, sequential indicator of the measurement (file index number). The file index number may be numbered from 00–31. As the next measurement is taken, the file index number is incremented.

If all four channels are making measurements and a save is performed, there will be four channel numbers that share the same file index number. For example, the files would be named txt100.csv, txt200.csv, txt300.csv, and txt400.csv. If a measurement does not include all four channels, unused channel-file index numbers will not be used by the next measurement. However, if all of the files that share a file index number are erased, that file index number will be re-used.

- csv is the file format, comma-separated value in this case.

Saving in Graphical (JPEG) Form

Graphical measurement results can be saved in JPEG format and used as an illustration in a text editor or desktop publishing application.¹ Up to eight traces may be saved in the JPEG file. This is done by storing a measurement using **DATA → MEMORY** and turning on **DATA AND MEMORY** for each of the four channels.

1. Press **Save/Recall** **SAVE FILE FORMATS**.
2. Make sure that **GRAPH FMT [JPG]** is displayed.
3. Make sure that **FILETYPE: GRAPHIC** is underlined. If it is not underlined, press the softkey so that GRAPHIC is underlined.
4. Insert a 3.5-inch floppy disk in the network analyzer's disk drive.
5. Press **SAVE FILE** to save the display as a graphic in the JPEG format.

The graphic file may be retrieved from the floppy disk on personal computer and can be imported into an application that accepts graphics in the JPEG format.

NOTE

When saving measurement results graphically, make sure that no onscreen measurement data is displayed as white. Since media color is often white, any measurement data printed using white will not be visible.

You may change the analyzer to the factory default color settings by pressing **Copy** **DEFINE PRINT** **DEFAULT PRNT SETUP** to correct this problem.

However, to maintain your current color settings (except white), check the measurement color settings by pressing **Copy** **DEFINE PRINT** **PRINT COLORS**. Press **MORE** to check the remaining measurement colors. To modify any of the measurement colors, select the measurement and then choose another color from the list of colors that is displayed.

1. The network analyzer firmware is based in part on the work of the Independent JPEG Group.

Instrument State Files

When an instrument state is saved to a floppy disk, some or all of the following files may be produced. This depends upon which arrays are selected under the **DEFINE SAVE STATE** softkey menu, and whether the selected save format is BINARY or ASCII. The “XX” part of the file name (FileXX) refers to the number of the instrument state. The first instrument state saved to any particular disk will be named “File00”, and each successive state saved to that disk will be numbered “1” higher than the previous state (for example, “File01” and “File02”).

Files with .i and .p File Extensions

The following two files (.i file and .p file) are always produced, except when **DATA ONLY** is selected. These files were separated to allow backward compatibility with older instruments. The binary data contained in these two files is not meant to be read in an external computer:

- FileXX.i is a binary file, which contains the generic portion of the current instrument state (specifically, the System, Local, Preset, Copy, Save, and Sequence settings).
- FileXX.p is a binary file which contains portions of the instrument state specific to later instruments.

Files with .10, .11, .12, .1a, .1b, and .1c File Extensions

The following files are only produced if you have an active calibration. FileXX.10 is a binary file which stores the stimulus state of the instrument as it relates to an active calibration (specifically, the Power, Sweep Setup, Start, Stop, Center, and Span settings).

The same type of file is produced if Channel 2 is active, but the file extension is .20 instead of the .10 file extension mentioned in the previous paragraph.

Files FileXX.11 through .12, .1a, .1b, and .1c are binary files which contain the 12 error correction coefficients for Channel 1. If Channel 2 is active, it will have the same array, but file extensions are in the form .21, .22, .2a., .2b, and .2c. If you save in ASCII format, only .10 and .1c are produced, with .1c containing the entire error correction array in a two-column, real/imaginary (CITIfile) format.

Files with File Extensions .r1 through .r8

FileXX.r1 through .r4 are produced when **RAW ARRAY on OFF** is turned ON. They may be either binary or ASCII, and contain the four raw uncorrected S-parameters for channel 1. Channel 2 has the same array, but file extensions are .r5 through .r8. In ASCII format, the data is displayed as two columns of real/imaginary numbers (CITIfile format); S11 appears first, S21 appears second, S12 appears third, and S22 appears last.

Files with .d1 and .d2 File Extensions

There are two type of files with .d1 and .d2 file extensions. There is FileXX.d1 (or .d2) and DataXX.d1 (or .d2).

FileXX.d1, produced only when **DATA ARRAY on OFF** is turned ON, may be either binary or ASCII. This file contains the error-corrected measurement data, but without port extensions or electrical delay. In ASCII format, this is a two-column real/imaginary array (CITIfile format), without any direct frequency information. S11 appears first, S21 second, S12 third, and S22 last. If Channel 2 is active, the same type of file is produced but the file extension is .d2. If dual display is on, both d1 and .d2 files are produced.

DataXX.d1, created only when **DATA ONLY on OFF** is turned ON, is either a binary file or an ASCII file in CITIfile format. Turning the **DATA ONLY on OFF** softkey ON suppresses the generation of all the previous file types. The contents of this file are identical to those of the FileXX.d1 file. The same type of file is produced if Channel 2 is active, but the file extension is .d2. If dual display is on, both .d1 and .d2 files are produced.

NOTE The DataXX files are much smaller than an entire instrument state, and are the best way to get just the data you want without saving the entire instrument state. Selecting more than one disk-save option does not confuse the analyzer, and simply produces all files associated with the selected options. The only exception to this is that selecting **DATA ONLY on OFF** suppresses all other selected options.

Files with .s1 and .s2 File Extensions

There are two type of files with .s1 and .s2 file extensions. There is FileXX.s1 (or .s2) and DataXX.s1 (or .s2).

With **DATA ONLY on OFF** Turned Off

FileXX.s1 is an ASCII file in Touchstone S2P format. Basically, this is a file in real/imaginary spreadsheet type format with five columns: frequency in the first column, S11 in the second column, S21 in the third, S12 in the fourth, and S22 in the fifth column. If Channel 2 is active, the same type of file is produced but the file extension is .s2. If dual display is on, both .s1 and .s2 are produced. These Touchstone S2P files are only produced when a full 2-port calibration is active and **SAVE USING ASCII** is selected. The effects of port extensions and electrical delay, if they are turned on, are included in the data.

With **DATA ONLY ON off** Turned On

DataXX.s1 is also an ASCII file in Touchstone S2P format. As with FileXX.s1, DataXX.s1 is a five-column real/imaginary spreadsheet type format where the columns are used the same as FileXX.s1. If Channel 2 is active, the same type of file is produced but the file extension is .s2. If dual display is on, both .s1 and .s2 are produced. These Touchstone S2P files are only produced when a full 2-port calibration is active and **SAVE USING ASCII** is selected. The effects of port extensions and electrical delay, if they are turned on, are included in the data.

Files with .g0 File Extension

FileXX.g0, produced only when **GRAPHICS on OFF** is turned ON, is a binary file containing the active measurement trace and display graphic. The contents of this file are not meant to be read in an external computer, so this file is only of use in the instrument.

Binary Files

The size of the data files is very small, about one tenth the size compared to the ASCII format. Binary is the format to use when you want to store and recall instrument states on the analyzer quickly, but do not need to read the data in an external computer.

Viewing Files Within the Analyzer

All these files are rolled up into a single instrument state, so the analyzer shows only the "FileXX" part of the name, without an extension. The file description will say ISTATE, followed by parentheses with letters in them, such as (CDG). These letters are explained on the bottom of the analyzer screen, and indicate some of what is included in that instrument state. In this example, the state includes the Calibration Array, Data, and Graphics.

The only way to see all the file extensions previously described is to save the instrument state to a disk and view the file structure on an external computer.

Saving Time Gated Frequency Data

Internal data processing is done sequentially beginning with raw data and ending with error correction and all formatting applied. The time domain processing occurs near the end of this processing chain, so data showing the effects of time domain processing is only available in "formatted arrays".

Differences between Raw, Data, and Format Arrays

The following discussion explains the data processing flow in the network analyzer. This information is very important if you will be utilizing data from your analyzer for use in computer applications such as spreadsheets, word processing, programs, etc. Refer to [Figure 4-13 on page 4-40](#).

The analyzer receives data from its A, B, and R or Aux-in inputs. Notice the three highlighted blocks. They represent the raw, data, and format arrays. You can save your measurement data in any or all of these format arrays each time the data is saved. Select the arrays of interest based on the factors discussed in this section.

For this discussion, only DISK saves will be described. Data can be saved to internal non-volatile memory or transferred over GPIB as well as to a floppy disk. You will find multiple files saved depending on the arrays chosen under the analyzer's **DEFINE DISK-SAVE** menu. When using these files, it is important to know which file extension is needed for your particular job.

Raw Arrays

On the analyzer, press the **Save/Recall** **DEFINE DISK-SAVE** **RAW ARRAY ON**

Data created the first time in this manner will be saved as filename "FILE00.r1". The file extension .r1 indicates the data was created while channel 1 was active and stored in the analyzer's raw data array. If you save the data again, but while channel 2 is active, you will get a new file called "FILE01.r2". RAW data are not commonly used unless sophisticated data processing is to be performed in an external PC. As an example, multi-port calibration is created by exporting raw data to a PC where error-correction for each of the multi-port paths is applied to them.

Data Arrays

Press **Save/Recall** **DEFINE DISK-SAVE** **DATA ARRAY ON**.

Data created the first time in this manner will be saved as filename "DATA00.d1." The file extension .d1 indicates that the data from the analyzer's channel 1 is error corrected data only if the analyzer's error correction feature is enabled (in other words, you have performed a calibration). Otherwise, the data is the same as data stored in the analyzer's raw data arrays. Data stored in the data arrays does not have any formatting applied to it.

Format Arrays

Press **Save/Recall** **DEFINE DISK-SAVE** **FORMAT ARY ON**

Data created the first time in this manner will be saved as filename "FILE00.f1". The file extension .f1 indicates the data is formatted per [Figure 4-13](#) using the analyzer's channel 1. Depending on what features you've selected, data in the format arrays includes data in the data arrays plus one or more of the following features:



- Trace math (i.e data-memory)
- Gating (Option 010)
- Electrical delay
- Conversion (for complex impedance (Z), admittance (Y), etc.)
- Transform (Option 010)
- Format (log, lin, phase, delay, SWR, excluding Smith and Polar)
- Smoothing

In each of these examples, most users will select **SAVE USING ASCII**, under the **DEFINE DISK-SAVE** softkey menu. If **GRAPHICS on OFF** is turned ON, an additional file will be created with file extension .g0. This is a Hewlett-Packard Graphics Language (HPGL) file.

Re-Saving an Instrument State

If you re-save a file, the analyzer overwrites the existing file contents.

NOTE You cannot re-save a file that contains data only. You must create a new file.

1. Press **Save/Recall** **SELECT DISK** and select the storage device.
 - INTERNAL MEMORY**
 - INTERNAL DISK**
 - EXTERNAL DISK** (If necessary, refer to the external disk setup procedure in ["Saving an Instrument State" on page 4-38.](#))
2. Press **RETURN** and then use the  or  key or the front-panel knob to highlight the name of the file that you want to re-save.
3. Press **RE-SAVE STATE** **YES**.

Deleting a File

1. Press **Save/Recall** **SELECT DISK**.
2. Choose from the following storage devices:
 - INTERNAL MEMORY**
 - INTERNAL DISK**
 - EXTERNAL DISK** (If necessary, refer to the external disk setup procedure in "[Saving an Instrument State](#)" on page 4-38.)
3. Press **RETURN**.



To Delete an Instrument State File

- Press the  or  keys or the front panel knob to highlight the name of the file that you want to delete.
- Press **FILE UTILITIES** **DELETE FILE** **YES** to delete all of the files that make up the selected instrument state.

To Delete all Files



- Press **FILE UTILITIES** **DELETE ALL FILES** **SAVE USING BINARY** to delete all of the files that are on the selected storage device.

Renaming a File

1. Press **Save/Recall** **AUTO-FEED OFF** .
2. Choose from the following storage devices:
 - INTERNAL MEMORY**
 - INTERNAL DISK**
 - EXTERNAL DISK** (If necessary, refer to the external disk setup procedure in ["Saving an Instrument State" on page 4-38.](#))
3. Press **RETURN** and then use the  or  keys or the front panel knob to highlight the name of the file that you want to rename.
4. Press **RETURN** **FILE UTILITIES** **RENAME FILE** **ERASE TITLE** .
5. Turn the front panel knob to point to each character of the new file name, pressing **SELECT LETTER** when the arrow points to each character. Press **BACK SPACE** if you enter an incorrect character. After you have selected all the characters in the new file name, press **DONE** .

NOTE Renaming files may also be done by using the optional external keyboard.

Recalling a File

1. Press **Save/Recall** **SELECT DISK** .
 2. Choose from the following storage devices:
 - INTERNAL MEMORY**
 - INTERNAL DISK**
 - EXTERNAL DISK** (If necessary, refer to the external disk setup procedure in "[Saving an Instrument State](#)" on page 4-38.)
 3. Press the  or  keys or the front panel knob to highlight the name of the file that you want to recall.
 4. Press **RETURN** **RECALL STATE** .
-

Formatting a Disk

1. Press **Save/Recall** **FILE UTILITIES** **FORMAT DISK** .
2. Choose the type of format you want:
 - FORMAT:LIF**
 - FORMAT:DOS**
3. Press **FORMAT EXT DISK** **YES** .

Solving Problems with Saving or Recalling Files

If you encounter a problem when you are storing files to disk, or the analyzer internal memory, check the following list for possible causes:

- Look in the analyzer display message area. The analyzer may show a message that will identify the problem. Refer to the "Error Messages" chapter of the reference guide if you view a message.
- Make sure that you are NOT using a single-sided floppy disk in the analyzer disk drive.
- Make sure that you are using a formatted disk.
- Make sure that the disk has not been formatted with the LIF-HFS (hierarchical file system) extensions as the analyzer does not support this format.

If You Are Using an External Disk Drive

- Make sure that the analyzer is in system controller mode, by pressing **Local** **SYSTEM CONTROLLER**.
- Make sure that you have connected the disk drive to ac power, switched on the power, and connected a GPIB cable between the disk drive and the analyzer.
- Make sure that the analyzer recognizes the disk drive's GPIB address, as explained in ["If You Are Plotting Measurement Results to a Disk Drive" on page 4-12](#).
- Make sure that the analyzer recognizes the disk (drive) unit that you selected (0 or 1).
- If the external disk is a hard disk, make sure that the disk volume number is set correctly.
- If the disk drive is an older HP 9122, it may not recognize the newer high density disks.
- Substitute the GPIB cable.
- Substitute the disk drive.

Printing, Plotting, and Saving Measurement Results
Solving Problems with Saving or Recalling Files

5 Optimizing Measurement Results

Using This Chapter

This chapter describes techniques and analyzer functions that help you achieve the best measurement results. The following topics are included in this chapter:

- ["Increasing Measurement Accuracy" on page 5-4](#)
 - Interconnecting cables
 - Improper calibration techniques
 - Sweeping too fast for electrically long devices
 - Connector repeatability
 - Temperature drift
 - Frequency drift
 - Performance verification
 - Reference plane and port extensions
- ["Maintaining Test Port Output Power During Sweep Retrace" on page 5-7](#)
- ["Making Accurate Measurements of Electrically Long Devices" on page 5-8](#)
- ["Increasing Sweep Speed" on page 5-10](#)
- ["Increasing Dynamic Range" on page 5-15](#)
- ["Reducing Noise" on page 5-16](#)
- ["Reducing Receiver Crosstalk" on page 5-18](#)
- ["Reducing Recall Time" on page 5-18](#)

Taking Care of Microwave Connectors

Proper connector care and connection techniques are critical for accurate, repeatable measurements.

Refer to the calibration kit documentation for connector care information. Prior to making connections to the network analyzer, carefully review the information about inspecting, cleaning and gaging connectors.

Having good connector care and connection techniques extends the life of these devices. In addition, you obtain the most accurate measurements.

This type of information is typically located in chapter 3 of the calibration kit manuals.

For additional connector care instruction, contact your local Agilent Technologies Sales and Service Office about course numbers HP/Agilent 85050A+24A and 85050A+24D.

See the following table for quick reference tips about connector care.

Table 5-1 Connector Care Quick Reference

Handling and Storage	
Do <ul style="list-style-type: none"> Keep connectors clean Extend sleeve or connector nut Use plastic end-caps during storage 	Do Not <ul style="list-style-type: none"> Touch mating-plane surfaces Set connectors contact-end down
Visual Inspection	
Do <ul style="list-style-type: none"> Inspect all connectors carefully Look for metal particles, scratches, and dents 	Do Not <ul style="list-style-type: none"> Use a damaged connector - ever
Connector Cleaning	
Do <ul style="list-style-type: none"> Try compressed air first Use isopropyl alcohol Clean connector threads 	Do Not <ul style="list-style-type: none"> Use any abrasives Get liquid into plastic support beads
Gaging Connectors	
Do <ul style="list-style-type: none"> Clean and zero the gage before use Use the correct gage type Use correct end of calibration block Gage all connectors before first use 	Do Not <ul style="list-style-type: none"> Use an out-of-spec connector
Making Connections	
Do <ul style="list-style-type: none"> Align connectors carefully Make preliminary connection lightly Turn only the connector nut Use a torque wrench for final connect 	Do Not <ul style="list-style-type: none"> Apply bending force to connection Over tighten preliminary connection Twist or screw any connection Tighten past torque wrench "break" point

Increasing Measurement Accuracy

The following all contribute to loss of accuracy in a measurement.

Interconnecting Cables

Cables that connect the device under test (DUT) to the analyzer are often the most significant contribution to random errors of your measurement. You should frequently perform the following steps as a precaution against errors caused by cable interconnections:

- Inspect for lossy cables.
- Inspect for damaged cable connectors.
- Practice good connector care techniques.
- Minimize cable position changes between error-correction and measurements.
- Inspect for cables which dramatically change magnitude or phase response when flexed. (This may indicate an intermittent problem.)

Improper Calibration Techniques

Calibrations techniques performed improperly contribute to random errors to your measurement. You should frequently perform the following steps as a precaution against errors caused by calibration techniques:

- Verify the correct calibration kit definition is selected.
- Verify the correct standards have been connected.

Sweeping Too Fast for Electrically Long Devices

It is possible to sweep too fast for electrically long devices. This will result in measurement error. Refer to ["Making Accurate Measurements of Electrically Long Devices" on page 5-8.](#)

Connector Repeatability

Connector repeatability is a source of random measurement error. Measurement error-corrections do not compensate for these errors. For all connectors, you should frequently perform the following steps as a precaution against errors caused by connector repeatability:

- Inspect the connectors.
- Clean the connectors.
- Gauge the connectors.
- Use correct connection techniques. (Refer to ["Taking Care of Microwave Connectors" on page 5-3.](#))

Temperature Drift

Electrical characteristics will change with temperature due to the thermal expansion characteristics of devices within the analyzer, calibration devices, test devices, cables, and adapters. Therefore, the operating

temperature is a critical factor in their performance. During a measurement calibration, the temperature of the calibration devices must be stable and within 25 ± 5 °C.

- Use a temperature-controlled environment.
- Ensure the temperature stability of the calibration devices.
- Avoid handling the calibration devices unnecessarily during calibration.
- Ensure the ambient temperature is ± 1 °C of measurement error-correction temperature.

Frequency Drift

Minute changes in frequency accuracy and stability can occur as a result of temperature and aging (on the order of parts per million). If you require greater frequency accuracy, override the internal crystal with a high-stability external source, frequency standard, or (if your analyzer is equipped with Option 1D5) use the internal frequency standard.

Performance Verification

You should periodically check the accuracy of the analyzer measurements, by performing a measurement verification at least once per year. The service guide includes the measurement verification procedure.

Reference Plane and Port Extensions

Use the port extension feature to compensate for the phase shift of an extended measurement reference plane, due to such additions as cables, adapters, and fixtures, after completing an error-correction procedure (or when there is no active correction).

Using port extensions is similar to using electrical delay. However, using port extensions is the preferred method of compensating for test fixture phase shift. [Table 5-2](#) explains the difference between port extensions and electrical delay.

Table 5-2 Differences between PORT EXTENSIONS and ELECTRICAL DELAY

	PORT EXTENSIONS	ELECTRICAL DELAY
Main Effect	The end of a cable becomes the test port plane for all S-parameter measurements.	Compensates for the electrical length of a cable. Set the cable's electrical length $\times 1$ for transmission. Set the cable's electrical length $\times 2$ for reflection.
Measurements Affected	All S-parameters.	Only the currently selected S-parameter.
Electrical Compensation	Intelligently compensates for 1 times or 2 times the cable's electrical delay, depending on which S-parameter is computed.	Only compensates for electrical length.

You can activate a port extension by pressing **Cal** **MORE** **PORT EXTENSIONS** **EXTENSIONS ON**. Then enter the delay to the reference plane.

Maintaining Test Port Output Power During Sweep Retrace

During standard operation, the analyzer provides output power during its forward frequency sweep, but may not provide output power during its sweep retrace. If the device under test (such as an amplifier with AGC circuitry) requires constant power, then you can set the analyzer to maintain test port output power during its sweep retrace.

To activate this feature, press **(System) CONFIGURE RETRCE PWR ON**. The analyzer now maintains test port output power during sweep retrace.

NOTE On the 8722ET/ES only, retrace power will be lost at the point when the sweep crosses the frequency boundary of 20 GHz.

NOTE The frequency sweep of the network analyzer is such that when it reaches 2.55 GHz, it momentarily jumps to 6.35 GHz before returning to 2.55 GHz and continuing the rest of the sweep. This discontinuity in the frequency sweep may be of concern to those making measurements of frequency sensitive amplifiers having AGC circuitry.

Making Accurate Measurements of Electrically Long Devices

A device with a long electrical delay, such as a long length of cable, a SAW filter, or normal devices measured over wide sweeps with very fast rates presents some unusual measurement problems to a network analyzer operating in swept frequency mode. Often the measured response is dependent on the analyzer's sweep time, and incorrect data may be obtained. At faster sweep rates, the magnitude of the response may seem to drop and look distorted, while at slower sweep rates it looks correct. The results may indicate that a cable has more loss than it truly does, or that a filter has some unusual ripple in the passband which is not really there.

This section describes the cause of this behavior, and how to accurately measure these electrically long devices.

The Cause of Measurement Problems

When using a vector network analyzer to measure a device that has a long electrical delay (ΔT), the device's time delay causes a frequency shift between its input and output signals. The frequency shift, ΔF , equals the product of the sweep rate and the time delay:

$$\Delta F = dF/dt \times \Delta T$$

Since frequency is changing with time as the analyzer sweeps, the time delay of the DUT causes a frequency offset between its input and output. In the analyzer receiver, the test and reference input signals will differ in frequency by ΔF . Because the test signal frequency is slightly different than the receiver frequency, the analyzer will err in measuring its magnitude or phase. The faster the analyzer's sweep rate, the larger ΔF becomes, and the larger the error in the test channel.



The analyzer does not sweep at a constant rate. The frequency range is covered in several bands, and the sweep rate may be different in each band. So if an operator sets up a broadband sweep with the minimum sweep time, the error in measuring a long device will be different in each band, and the data will be discontinuous at each band edge. This can produce confusing results which make it difficult to determine the true response of the device.

To Improve Measurement Results

To reduce the error in these measurements, the frequency shift, ΔF , must be reduced. ΔF can be reduced by using the following methods:

- using step sweep mode
- decreasing the sweep rate
- decreasing the time delay (ΔT)

Decreasing the Sweep Rate

The sweep rate can be decreased by increasing the analyzer's sweep time. To increase the analyzer's sweep time, press **Sweep Setup** **SWEEP TIME [MANUAL]** and use the front panel knob, the  and  keys, or the front panel keypad enter in the appropriate sweep time.

Alternatively, the number of points may be increased for the same frequency range, thereby reducing the sweep rate (in GHz/second).

Selection of the appropriate sweep time depends on the device being measured; the longer the electrical delay of the device under test, the slower the sweep rate must be. A good way to tell when the sweep rate is slow enough is to put the vector network analyzer into a stepped mode of sweeping (**Sweep Setup** **SWEEP TYPE MENU** **STEP SWP ON off**), and compare the data. In this mode, the vector network analyzer does not sweep the frequency, but steps to each frequency point, stops, makes a measurement, then goes on to the next point. Because errors do not occur in the stepped frequency mode, it can be used to check the data. The disadvantage of the stepped frequency mode is that it is slower than sweeping.

Decreasing the Time Delay

The other way to reduce ΔF is by decreasing the time delay, ΔT . Since ΔT is a property of the device that is being measured, it cannot literally be decreased. However, what can be decreased is the difference in delay times between the paths to the R channel and the B channel. These times can be equalized by adding a length of cable to the R channel which has approximately the same delay as the device under test.

This length of cable can be inserted between the R CHANNEL IN and OUT connectors on the front panel of the analyzer. The delay of this cable must be less than $5\mu\text{s}$.

Increasing Sweep Speed

You can increase the analyzer sweep speed by avoiding the use of some features that require computational time for implementation and updating, such as bandwidth marker tracking.

You can also increase the sweep speed by making adjustments to the measurement settings. The following suggestions for increasing sweep speed are general rules that you should experiment with:

- use swept list mode
- decrease the frequency span
- set the auto sweep time mode
- widen the system bandwidth
- reduce the averaging factor
- reduce the number of measurement points
- set the sweep type
- use chop sweep mode
- use external calibration
- use fast 2-port calibration mode

To Use Swept List Mode

When using a list frequency sweep, choosing swept list mode can increase throughput by up to 6 times over stepped list mode. This mode takes data while sweeping through each list segment. In addition, this mode expands the list table to include test port power and IF bandwidth. Selectable IF bandwidths can increase the throughput of the measurement by allowing the user to specify narrow bandwidths only where needed.

- For in-depth information on swept list mode, refer to ["Swept List Frequency Sweep \(Hz\)" on page 7-17](#).
- For more information on making measurements with swept list mode, refer to ["Using the Swept List Mode to Test a Device" on page 1-67](#).

1. To set up a swept list measurement, press **Sweep Setup** **SWEEP TYPE MENU** **EDIT LIST** **ADD** .
2. The frequency segments can be defined in any of the following terms:
 - start/stop/number of points/power/IFBW
 - start/stop/step/power/IFBW
 - center/span/number of points/power/IFBW
 - center/span/step/power/IFBW
3. When finished, press **DONE** **LIST TYPE: [SWEPT]** .

Sweep Speed-Related Errors

IF delay occurs during swept measurements when the signal from the analyzer source is delayed in reaching the analyzer receiver because of an electrically long device. The receiver has a narrow IF band pass filter

that tracks the receiver frequency because the receiver is sweeping. The delayed signal will be attenuated because the center of the internal IF filter has moved.

For most measurements, swept list mode will be the optimum choice. If there is any doubt about the effect of IF delay, perform the following test:

1. Set up the measurement using the swept list mode, as in the previous procedure.
2. Make the measurement and save the data trace to memory:

Display DATA → MEMORY **DISPLAY: DATA** and **MEMORY**

3. Then switch to stepped list mode:

Sweep Setup SWEEP TYPE MENU **EDIT LIST** **LIST TYPE: [STEPPED]** **DONE**

- If there is no difference between the measurements in either list mode, then use the swept list mode.
- If the memory trace indicates that there is more attenuation in swept list mode, it may be due to IF delay. You can usually remedy this problem by increasing the sweep time.

NOTE IF bandwidths of 30 to 10 Hz cause the sweep (or that segment of the sweep) to always be stepped, thus eliminating IF delay.

To Decrease the Frequency Span

The hardware of the network analyzer sweeps the frequency range in separate bands, where switching from band to band takes time. Modify the frequency span to eliminate as many band switches as possible while maintaining measurement integrity. Refer to the following table to identify the analyzer's band switch points:

Table 5-3 Band Switch Points

Band	Frequency Span	Band	Frequency Span
1	50 MHz to 110 MHz	8	2.55 GHz to 4.71 GHz
2	110 MHz to 230 MHz	9	4.71 GHz to 8.256 GHz
3	230 MHz to 470 MHz	10	8.256 GHz to 13.562 GHz
4	470 MHz to 698 MHz	11 (8720ET/ES and 8722ET/ES)	13.562 GHz to 20.05 GHz
5	698 MHz to 1.17 GHz	12 (8722ET/ES)	20.05 GHz to 25.0 GHz
6	1.17 GHz to 1.878 GHz	13 (8722ET/ES)	25.0 GHz to 40.0 GHz
7	1.878 GHz to 2.55 GHz		

To Set the Auto Sweep Time Mode

Auto sweep time mode is the default mode (the preset mode). This mode maintains the fastest sweep speed possible for the current measurement settings.

Optimizing Measurement Results

Increasing Sweep Speed

- Press **Sweep Setup** **SWEEP TIME** **0**, to re-enter the auto mode.

To Widen the System Bandwidth

1. Press **Avg** **IF BW**.
2. Increase the IF bandwidth to increase the sweep speed.

The specifications and characteristics chapter of the reference guide shows the relative increase in sweep time as you decrease system bandwidth.

To Reduce the Averaging Factor

By reducing the averaging factor (number of sweeps) or switching averaging off, you can increase the analyzer's measurement speed. The time needed to compute averages can also slow the sweep time slightly, in narrow spans.

1. Press **Avg** **AVG FACTOR**.
2. Enter an averaging factor that is less than the value displayed on the analyzer screen and press **x1**.
3. If you want to switch off averaging, press **Avg** **AVERAGING OFF**.

To Reduce the Number of Measurement Points

1. Press **Menu** **NUMBER OF POINTS**.
2. Enter a number of points that is less than the value displayed on the analyzer screen and press **x1**.

Refer to the "Specifications and Characteristics" chapter of the reference guide for examples of how sweep time changes with the number of points.

To Set the Sweep Type

Different sweep speeds are associated with the following three types of non-power sweeps. Choose the sweep type that is most appropriate for your application.

1. Press **Sweep Setup** **SWEEP TYPE MENU**.
2. Select the sweep type:
 - Select **LIN FREQ** for the fastest sweep for a given number of fixed points.
 - Select **LIST FREQ** for the fastest sweep when specific non-linearly spaced frequency points are of interest.
 - Select **LOG FREQ** for the fastest sweep when the frequency points of interest are in the lower part of the frequency span selected.

To View a Single Measurement Channel

Viewing a single channel will increase the measurement speed if the analyzer's channels are in alternate, or uncoupled mode.

1. Press **Display** **DUAL | QUAD SETUP** **DUAL CHAN on OFF** **AUX CHAN on OFF**.

2. Press **Chan 1** and **Chan 2** to alternately view the two measurement channels.

If you must view both measurement channels simultaneously (with dual channel), use the chop sweep mode, explained next.

3. If you want to view channel 3 (or channel 4), press **Chan 3** (or **Chan 4**). This will always result in a dual trace display of channel 1 and channel 3 (or channel 2 and channel 4).

To return to a single-trace display, press **Display** **DUAL | QUAD SETUP**
AUX CHAN on OFF.

To Activate Chop Sweep Mode

You can use the chop sweep mode to make two measurements at the same time. For example, the analyzer can measure S11 and S21 simultaneously. You can activate the chop mode by pressing **Preset** or by pressing **Cal** **MORE** **CHOP A and B**.

While Chop mode is the fastest way to measure devices, some components, such as filters with very high attenuation, may require measurement in Alternate mode. See ["Increasing Dynamic Range" on page 5-15](#).

To Use External Calibration

Off-loading the error correction process to an external PC increases throughput on the network analyzer. This can be accomplished with remote-only commands. Refer to the programmer's guide for information on how to use external calibration.

To Use Fast 2-Port Calibration (ES Analyzers Only)

With a 2-port calibration on, faster trace updates are possible by not measuring the reverse path for every forward sweep. This is controlled by the test set switch command. This is convenient for tuning applications because it gives a faster trace update.

When making measurements using full two-port error-correction, the following types of test set switching can be defined by the user:

- **Hold:** In this mode the analyzer does not switch between the test ports on every sweep. The measurement stays on the active port after an initial cycling between the ports. The fastest measurements can be made by using this type of test set switching. Pressing the **Meas** key, changing to a different S-parameter measurement, or any other action which restarts a sweep will cause the test set to switch and cycle between the ports.

Optimizing Measurement Results

Increasing Sweep Speed

- **Continuous:** In this mode the analyzer will switch between the test ports on every sweep. Although this type of test set switching provides the greatest measurement accuracy, it requires a reverse sweep for every forward sweep.

NOTE Analyzers configured with Option 007 or Option 085 use a mechanical switch and are not allowed to switch between test ports on every sweep in Continuous mode. A `trsh` indicator appears on the display instead.

- **Number of Sweeps:** In this mode there is an initial cycling between the test ports and then the measurement stays on the active port for a user-defined number of sweeps. After the specified number of sweeps have been executed, the analyzer switches between the test ports and begins the cycle again. This type of test set switching can provide improved measurement accuracy over the hold mode and faster measurement speeds than continuous mode.

NOTE **Fast 2-Port Calibration Accuracy**

For most devices, the fast 2-Port Calibration method is nearly as accurate as the full 2-Port Calibration method.

1. To access the test set switch functions, press:

`Cal` `MORE` `TESTSET SW CONTINUOUS`

2. To activate the hold mode, press:

`0` `x1`

The analyzer will then display the softkey as `TESTSET SW HOLD`.

3. To activate the continuous mode, press:

`1` `x1`

The analyzer will then display `TESTSET SW CONTINUOUS`.

4. To enter the number of sweeps, (for this example, 8 sweeps) press:

`8` `x1`

The analyzer will then display the softkey as `TESTSET SW 8 Sweeps`.

Increasing Dynamic Range

Dynamic range is the difference between the analyzer's maximum allowable input level and minimum measurable power. For a measurement to be valid, input signals must be within these boundaries. The dynamic range is affected by these factors:

- test port input power
- test port noise floor
- receiver crosstalk

Increase the Test Port Input Power

You can increase the analyzer's source output power so that the test device output power is at the top of the measurement range of the analyzer test port.

Press **Power** and enter the new source power level, followed by **x1**.

CAUTION Do not exceed the maximum test port power level that is printed on the front panel of your network analyzer. Exceeding this maximum power level may damage your analyzer.

Reduce the Receiver Noise Floor

Refer to ["Reducing Noise" on page 5-16](#).

Reduce the Receiver Crosstalk

Refer to ["Reducing Receiver Crosstalk" on page 5-18](#).

Reducing Noise

You can use two analyzer functions to help reduce the effect of noise on the data trace:

- activate measurement averaging
- reduce system bandwidth
- use direct sampler access configurations (Option 012 Only)

To Activate Averaging

The noise is reduced with each new sweep as the effective averaging factor increments.

1. Press **Avg** **AVERAGING FACTOR**.
2. Enter a value followed by **x1**.
3. Press **AVERAGING ON**.

Refer to ["Averaging" on page 7-34](#) for more information.

To Change System Bandwidth

By reducing the system bandwidth, you reduce the noise that is measured during the sweep. While averaging requires multiple sweeps to reduce noise, narrowing the system bandwidth reduces the noise on each sweep, however, the sweep will be slower.

1. Press **Avg** **IF BW**.
2. Enter the IF bandwidth value that you want, followed by **x1**.

Narrower system bandwidths cause longer sweep times. When in auto sweep time mode, the analyzer uses the fastest sweep time possible for any selected system bandwidth. Auto sweep time mode is the default (preset) analyzer setting.

NOTE Another capability that can be used for effective noise reduction is the marker statistics function, which computes the average value of part or all of the formatted trace.

If your instrument is equipped with Option 085 (High Power System), another way of increasing dynamic range is to increase the input power to the test device using a booster amplifier.

To Use Direct Sampler Access Configurations (Option 012 Only)

Direct sampler access to both the A and B samplers can decrease the noise floor of the analyzer.

In the standard configuration (Option 012 with all jumpers in place), the signal entering one of the test ports passes through a coupler with 14 dB coupling before it reaches the sampler. Thus, the input signal is reduced by approximately 14 dB before it reaches the sampler. By using direct sampler access and inputting the signal from the DUT directly in the A or B sampler input, you can improve the noise floor of the analyzer by 14 dB.

Figure 5-1 Increased Dynamic Range Configuration

FORWARD CONFIGURATION

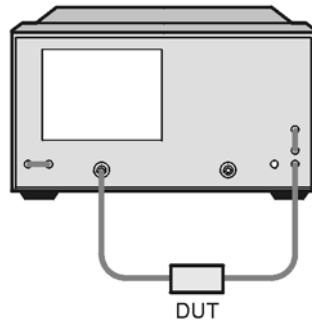

pa5189e

Reducing Receiver Crosstalk

To reduce receiver crosstalk you can do the following:

- Perform a response and isolation measurement calibration.
- Set the sweep to the alternate mode.

Alternate sweep is intended for measuring wide dynamic range devices, such as high pass and bandpass filters. This sweep mode removes a type of leakage term through the device under test, from one channel to another.

To set the alternate sweep, press **Cal** **MORE** **ALTERNATE A and B**.

Refer to ["Frequency Response and Isolation Error Corrections"](#) on page 6-17.

Reducing Recall Time

To reduce time during recall and frequency changes, the raw offset function can be turned off. To turn this function off, press **System** **CONFIGURE MENU** **RAW OFFSET OFF**.

The raw offset function is normally on and controls the sampler and attenuator offsets. The creation of this table takes some time during a recall of an instrument state.

Raw offsets may be turned on or off individually for each channel. They follow the channel coupling. For dual channel operation, raw offsets should be turned off for each channel if the channels are uncoupled.

Refer to "Specifications and Characteristics" chapter in the reference guide for examples of recall state times with the following functions on or off: raw offsets and blank display. Using blank display may speed up recall times.

6 Calibrating for Increased Measurement Accuracy

How to Use This Chapter

This chapter is divided into the following subjects:

- ["Calibration Considerations" on page 6-4](#)
- ["Procedures for Error Correcting Your Measurements" on page 6-10](#)
 - frequency response error correction
 - frequency response and isolation error correction
 - enhanced frequency response error correction (with enhanced reflection error correction)
 - one-port reflection error correction
 - full two-port error correction (ES Analyzers Only)
- ["Power Meter Measurement Calibration" on page 6-33](#)
- ["Calibrating for Noninsertable Devices" on page 6-40](#)
 - adapter removal calibration (ES Analyzers Only)
 - matched adapters
 - modify the cal kit thru definition
- ["Calibrating for Non-Coaxial Devices \(ES Analyzers Only\)" on page 6-50](#)
 - TRL calibration
 - LRM calibration
- ["Calibrating Using Electronic Calibration \(ECal\)" on page 6-57](#)
- ["Adapter Removal Using ECal \(ES Analyzers Only\)" on page 6-68](#)

Introduction

The accuracy of network analysis is greatly influenced by factors external to the network analyzer. Components of the measurement setup, such as interconnecting cables and adapters, introduce variations in magnitude and phase that can mask the actual response of the device under test.

Error correction is an accuracy enhancement procedure that removes systematic errors (repeatable measurement variations) in the test setup. The analyzer measures known standard devices, and uses the results of these measurements to characterize the system.

Measurement accuracy and system characteristics can be affected by the following factors:

- Adapting to a different connector type or impedance.
- Connecting a cable between the test device and an analyzer test port.
- Connecting any attenuator or other such device on the input or output of the test device.

If your test setup meets any of the these conditions, the following system characteristics may be affected:

- amplitude at device input
- frequency response accuracy
- directivity
- crosstalk (isolation)
- source match
- load match

Calibration Considerations

Measurement Parameters

Calibration procedures are parameter-specific, rather than channel-specific. When a parameter is selected, the instrument checks the available calibration data, and uses the data found for that parameter. For example, if a transmission response calibration is performed for B/R, and an S_{11} 1-port calibration for A/R, the analyzer retains both calibration sets and corrects whichever parameter is displayed. Once a calibration has been performed for a specific parameter or input, measurements of that parameter remain calibrated in either channel, as long as stimulus values are coupled. In the response and response and isolation calibrations, the parameter must be selected before calibration. Other correction procedures select parameters automatically. Changing channels during a calibration procedure invalidates the part of the procedure already performed.

Device Measurements

In calibration procedures that require measurement of several different devices, for example a short, an open, and a load, the order in which the devices are measured is not critical. Any standard can be re-measured, until the **DONE** key is pressed. The change in trace during measurement of a standard is normal.

“Response” and “response and isolation” calibrations require measurement of only one standard device. If more than one device is measured, only the data for the last device is retained.

Clarifying Type-N Connector Sex

When you are performing error correction for a system that has type-N port connectors, the softkey menus label the sex of the test port connector — *not* the calibration standard connector. For example, the label, SHORT (F), refers to the short that will be connected to the female test port. Since many devices have type-N (f) connectors, the calibration standard to select is the type-N (m). Be sure to use the port extension pin on the type-N (m) Open calibration standard.

NOTE Since the 85032F calibration kit offsets are equal for both male and female connectors, the standard’s sex type is not requested during the calibration.

Omitting Isolation Calibration

Isolation calibration can be omitted for most measurements, except where high dynamic range is a consideration. Use the following guidelines. When the measurement requires a dynamic range of:

- Less than 90 dB: Omit isolation calibration for most measurements.

- 90 to 100 dB: Isolation calibration is recommended with test port power greater than 0 dBm. For this isolation calibration, averaging should be turned on with an averaging factor at least four times the measurement averaging factor. For example, use an averaging factor of 16 for the isolation calibration, and then reduce the averaging factor to four for the measurement after calibration.
- Greater than 100 dB: Same as 90 to 100 dB, but alternate mode should be used. See ["To View a Single Measurement Channel" on page 5-12](#).

Saving Calibration Data

You should save the calibration data, either in the internal non-volatile memory or on a disk. If you do not save it, it will be lost if you select another calibration procedure for the same channel, or if you change stimulus values. Instrument preset, power on, and instrument state recall will also clear the calibration data.

Restarting a Calibration

If you interrupt a calibration to go to another menu, such as averaging, you can continue the calibration by pressing the **RESUME CAL SEQUENCE** softkey in the correction menu.

The Calibration Standards

During measurement calibration, the analyzer measures actual, well-defined standards and mathematically compares the results with ideal "models" of those standards. The differences are separated into error terms which are later removed during error correction. Most of the differences are due to systematic errors—repeatable errors introduced by the analyzer, test set, and cables—which are correctable.

The standard devices required for system calibration are available in compatible calibration kits with different connector types. Each kit contains at least one short circuit, one open circuit, and an impedance-matched load. In kits that require adapters for interface to the test set ports, the adapters are phase-matched for calibration prior to measurement of non-insertable and non-reversible devices. Other standard devices can be used by specifying their characteristics in a user-defined kit, as described in ["Modifying Calibration Kits" on page 7-57](#).

The accuracy improvement of the correction is limited by the quality of the standard devices, and by the connection techniques used. For maximum accuracy, ensure that the connectors are clean and use a torque wrench for final connections.

Electronic calibration (ECal) modules serve as the calibration standards for electronic calibration procedures. ECal modules are electronic networks that simulate impedance states that are similar to mechanical standards. The factory error correction for optimum performance is embedded in the module's memory.

Frequency Response of Calibration Standards

In order for the response of a reference standard to show as a dot on the smith chart display format, it must have no phase shift with respect to frequency. Standards that exhibit such "perfect" response are the following:

- 7-mm short (with no offset)
- type-N male short (with no offset)

There are two reasons why other types of reference standards show phase shift after calibration:

- The reference plane of the standard is electrically offset from the mating plane of the test port. Such devices exhibit the properties of a small length of transmission line, including a certain amount of phase shift.
- The standard is an open termination, which by definition exhibits a certain amount of fringe capacitance (and therefore phase shift). Open terminations which are offset from the mating plane will exhibit a phase shift due to the offset in addition to the phase shift caused by the fringe capacitance.

The most important point to remember is that these properties will not affect your measurements. The analyzer compensates for them during measurement. As a result, if these standards are measured after a calibration, they will not appear to be "perfect" shorts or opens. This is an indication that *your analyzer is working properly* and that it has successfully performed a calibration. [Figure 6-1](#) shows sample displays of various calibration standards after calibration.

Electrical Offset

Some standards have reference planes that are electrically offset from the mating plane of the test port. These devices will show a phase shift with respect to frequency. [Table 6-1](#) shows which reference devices exhibit an electrical offset phase shift. The amount of phase shift can be calculated with the formula:

$\Phi = (360^\circ \times f \times l)/c$ where:

f = frequency

l = electrical length of the offset

c = speed of light (3×10^8 meters/second)

Fringe Capacitance

All open circuit terminations exhibit a phase shift over frequency due to fringe capacitance. Offset open circuits have increased phase shift because the offset acts as a small length of transmission line. Refer to [Table 6-1](#).

Table 6-1 Calibration Standard Types and Expected Phase Shift

Test Port Connector Type	Standard Type	Expected Phase Shift
7-mm Type-N male	Short	180°
3.5-mm male 3.5-mm female 2.4-mm male 2.4-mm female Type-N female 75Ω Type-N female	Offset Short	$180^\circ + \frac{(360^\circ \times f \times l)}{c}$
7-mm Type N-male	Open	$0^\circ + \Phi_{\text{capitance}}^\circ$
3.5-mm male 3.5-mm female 2.4-mm male 2.4-mm female Type-N female 75Ω Type-N female	Offset Open	$0^\circ + \Phi_{\text{capitance}}^\circ + \frac{(360^\circ \times f \times l)}{c}$

Figure 6-1 Typical Responses of Calibration Standards after Calibration

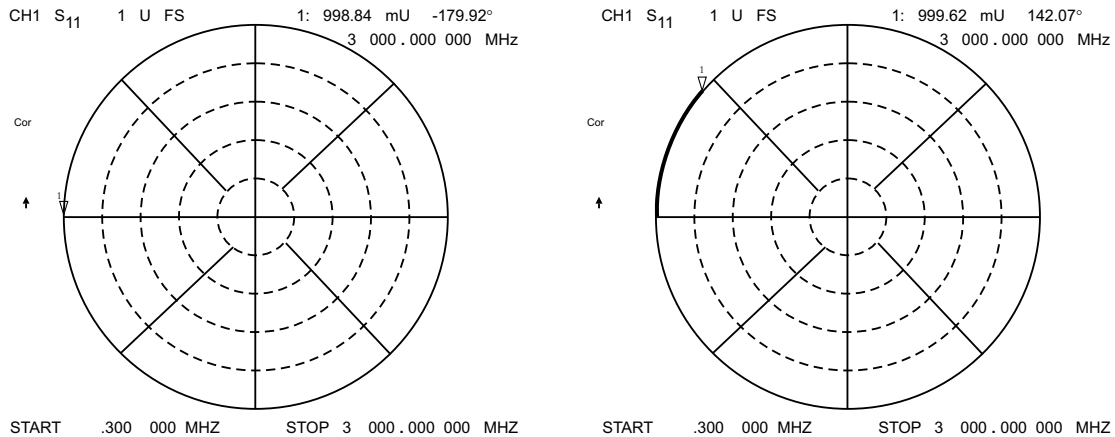

**7mm or Type-N Male
 Short (No Offset)**

**Type-N Female,
 3.5mm Male or Female Offset Short**

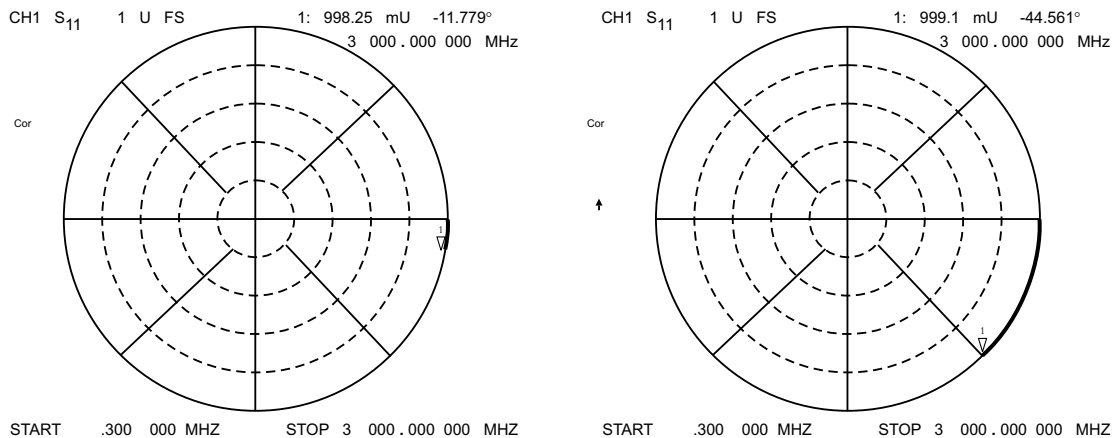

**7mm or Type-N Male
 Open (No Offset) with Fringing Capacitance**

**Type-N Female
 3.5 mm Male or Female Offset Open**

pa5162e

Interpolated Error Correction

You may want to use interpolated error correction when you choose a subset of a frequency range that you already corrected, when you change the number of points, or when you change to CW. This feature also allows you to change the parameters in a 2-port correction, such as IF bandwidth, power, or sweep time. The analyzer calculates the systematic errors from the errors of the original correction.

To activate interpolated measurement correction, press **Cal** **INTERPOL ON off** so that ON is selected, and **CORRECTION on OFF** so that ON is selected. When interpolation is in use, the notation **CΔ** will appear on the analyzer display.

NOTE The preset state of the instrument can be configured so that interpolated error correction is on or off. Press **(System)** **CONFIGURE MENU** **USER SETTINGS** **PRESET SETTINGS** **CAL INTERP ON off** to configure the preset state of interpolated error correction.

System performance is unspecified when using interpolated error correction. The quality of the interpolated error correction is dependent on the amount of phase shift and the amplitude change between measurement points. If phase shift is no greater than 180° per approximately five measurement points, interpolated error correction offers a great improvement over uncorrected measurements. The accuracy of interpolated error correction improves as the phase shift and amplitude change between adjacent points decrease. When you use the analyzer in linear frequency sweep, perform the original calibration with at least 30 points per 1 GHz of frequency span for greatest accuracy with interpolated error correction.

Interpolated error correction is available in three sweep modes: linear frequency, power sweep, and CW time.

NOTE If there is a valid correction array for a linear frequency sweep, this may be interpolated to provide correction at the CW frequency used in power sweep or CW time modes. This correction is part of the interpolated error-correction feature.

Error-Correction Stimulus State

Error correction is only valid for a specific stimulus state, which you must select before you start a correction. If you change any of the following parameters, you will invalidate the correction and the analyzer will switch the correction off (unless the interpolated error correction feature is activated):

- frequency range
- number of points
- sweep type

The error correction quality may be degraded (COR changes to CΔ), if you change the following stimulus state parameters:

- sweep time
- system bandwidth
- output power

If correction is turned off or shows CΔ, the original stimulus state can be recalled by, first, turning interpolation off (**INTERPOL ON off**), and toggling correction off and then on (**CORRECTION ON off**).

Procedures for Error Correcting Your Measurements

This section has example procedures or information on the following topics:

- frequency response correction
- frequency response and isolation correction
- enhanced frequency response correction (with enhanced reflection error correction)
- one-port reflection correction
- full two-port correction (ES Analyzers Only)
- TRL*/LRM* correction (ES Analyzers Only)
- power meter measurement calibration procedure

NOTE If the channels are uncoupled, you must make a correction for each channel.

Types of Error Correction

Several types of error correction are available that remove from one to twelve systematic errors. The full 2-port correction effectively removes all twelve correctable systematic errors. Some measurements do not require correction for all twelve errors. [Table 6-2](#) explains each correction and its uses.

Table 6-2 Purpose and Use of Different Error Correction Procedures

Correction Procedure	Corresponding Measurement	Errors Corrected	Standard Devices
Response	Transmission or reflection measurement when the highest accuracy is not required.	Frequency response.	Thru for transmission, open or short for reflection.
Response & Isolation	Transmission of high insertion loss devices or reflection of high return loss devices. Not as accurate as 1-port or 2-port correction.	Frequency response plus isolation in transmission or directivity in reflection.	Same as response plus isolation standard. (load)
Enhanced Response and Enhanced Reflection	Transmission or reflection measurement when improved accuracy is desired. Not as accurate as 2-port calibration.	Directivity, source match, and frequency response for reflection. Frequency response, source match, and isolation for transmission. Enhanced reflection corrects for load match on bilateral devices.	Short, open, load, and thru or ECal module.

Table 6-2 Purpose and Use of Different Error Correction Procedures

Correction Procedure	Corresponding Measurement	Errors Corrected	Standard Devices
S ₁₁ 1-port	Reflection of any one-port device or well terminated two-port device.	Directivity, source match, frequency response.	Short, open and load or ECal module.
S ₂₂ 1-port (ES Analyzers Only)	Reflection of any one-port device or well terminated two-port device.	Directivity, source match, frequency response.	Short, open and load or ECal module.
Full 2-port (ES Analyzers Only)	Transmission or reflection of highest accuracy for two-port devices.	Directivity, source match, load match, isolation, frequency response, forward and reverse.	Short, open, load and thru (2 loads for isolation) or ECal module
TRL*/LRM* (ES Analyzers Only)	Transmission or reflection in noncoaxial environment such as in a fixture or on-wafer.	Directivity, isolation, frequency response. (forward and reverse)	Thru, reflect, line, or line, reflect, match, or thru, reflect, match.
TRL/LRM (ES analyzers with Option 400 only)	Transmission or reflection in noncoaxial environments. More accurate than TRL*/LRM*.	Directivity, isolation, frequency response. (forward and reverse)	Thru, reflect, line, or line, reflect, match, or thru, reflect, match.

NOTE Response calibration is not as accurate as other calibration methods.

Frequency Response Error Corrections

You can remove the frequency response of the test setup for the following measurements:

- reflection measurements
- transmission measurements
- combined reflection and transmission measurements

Response Error Correction for Reflection Measurements

1. Press **Preset**.
2. Select the type of measurement you want to make.
 - If you want to make a reflection measurement on PORT 1 (in the forward direction, S_{11}), leave the instrument default setting.
 - For ES analyzers, if you want to make a reflection measurement on PORT 2 (in the reverse direction, S_{22}), press:

Meas **Refl: REV S22 (B/R)**

3. Set any other measurement parameters that you want for the device measurement: power, sweep type, number of points, or IF bandwidth.
4. To access the measurement error-correction menus, press:

Cal **CALIBRATE MENU**

5. If your calibration kit is different than the kit specified under the **Cal** **CAL KIT []** softkey, press:

Cal **CAL KIT** **SELECT CAL KIT** (select your type of kit) **RETURN**

If your type of calibration kit is not listed in the displayed menu, refer to ["Modifying Calibration Kits" on page 7-57](#).

6. To select a response correction, press:

Cal **CALIBRATE MENU** **RESPONSE**

Connect the short or open calibration standard to the port you selected for the test port (PORT 1 for S_{11} or PORT 2 for S_{22} on ES analyzers).

NOTE Include any adapters or cables that you will have in the device measurement. That is, connect the standard device to the particular connector where you will connect your DUT.

Figure 6-2 Standard Connections for a Response Error Correction for Reflection Measurement

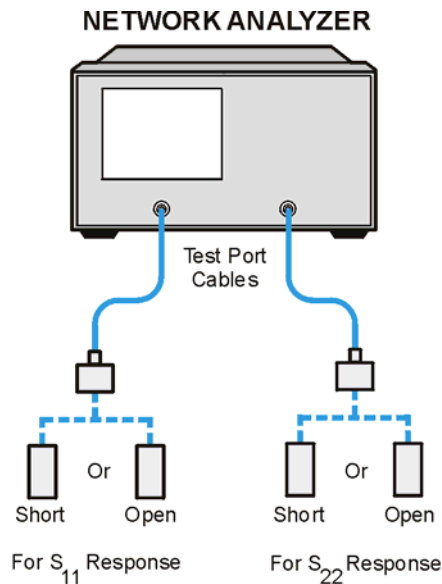

pa576e

7. To measure the standard when the displayed trace has settled, press **SHORT** or **OPEN**.

If the calibration kit you selected has a choice between male and female calibration standards, remember to select the sex that applies to the test port and not the standard.

The analyzer displays **WAIT - MEASURING CAL STANDARD** during the standard measurement. The analyzer underlines the softkey that you selected after it finishes the measurement, and computes the error coefficients.

NOTE This calibration allows *only* one standard to be measured. If you press the wrong key for a standard, press **RESPONSE** again and choose the correct standard. *Do not* use a thru standard for a reflection response correction.

NOTE You can save or store the measurement correction to use for later measurements, that use the same measurement parameters. Refer to the [Chapter 4, "Printing, Plotting, and Saving Measurement Results"](#) for procedures.

This completes the response correction for reflection measurements. You can connect and measure your device under test.

Response Error Correction for Transmission Measurements

1. Press **Preset**.
2. Select the type of measurement you want to make.
 - If you want to make a transmission measurement in the forward direction (S_{21}), press:
Meas **Trans: FWD S21 (B/R)** or on ET models: **TRANSMISSN**
 - For ES analyzers, if you want to make a transmission measurement in the reverse direction (S_{12}), press:
Meas **Trans: REV S12 (A/R)**
3. Set any other measurement parameters that you want for the device measurement: power, number of points, IF bandwidth.
4. To select a response correction, press:
Cal **CALIBRATE MENU** **RESPONSE**
5. Make a "thru" connection between the points where you will connect your DUT.

NOTE Include any adapters or cables that you will have in the device measurement. That is, connect the standard device where you will connect your DUT.

Figure 6-3 Standard Connections for Response Error Correction for Transmission Measurements

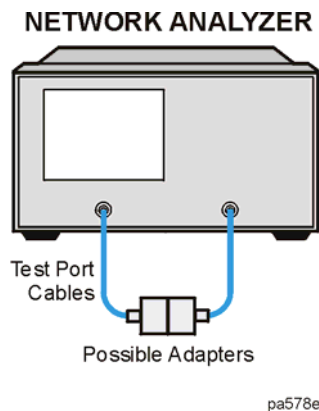

6. To measure the standard, press:

THRU

The analyzer displays **WAIT - MEASURING CAL STANDARD** during the standard measurement. The analyzer underlines the **THRU** softkey after it measures the calibration standard, and computes the error coefficients.

NOTE *Do not* use an open or short standard for a transmission response correction.

NOTE You can save or store the measurement correction to use for later measurements. Refer to the [Chapter 4 , "Printing, Plotting, and Saving Measurement Results"](#) for procedures.

7. This completes the response correction for transmission measurements. You can connect and measure your device under test.

Receiver Calibration

Receiver calibration provides a frequency response error correction for a non-ratioed measurement that also indicates absolute power in dBm. This calibration is most useful when performed with a power meter calibration. This calibration is only allowed for non-ratioed measurements A, B, and R.

This calibration normalizes the trace to the current reference value. Typically, this reference value is entered to be the same as the current source power.

1. Perform a power meter calibration to the desired level. Refer to step A of [Figure 6-4](#). Use -10 dBm for this example. (See also, "[Power Meter Measurement Calibration](#)" on page 6-33.) This provides a calibrated power, referenced to the power meter, to use as a receiver calibration standard.

or

Set the analyzer test port power to the desired level (-10 dBm in this example) by pressing:

Power **-10** **x1**. This calibrates the receiver to the approximate accuracy of the source output power, which is subject to the source power flatness specification.

2. Make a "thru" connection between the points where you will connect your device under test. Refer to Step B of [Figure 6-4](#).

NOTE Include any adapters or cables that you will have in the device measurement. That is, connect the standard device where you will connect your device under test.

Figure 6-4 Standard Connections for a Receiver Calibration

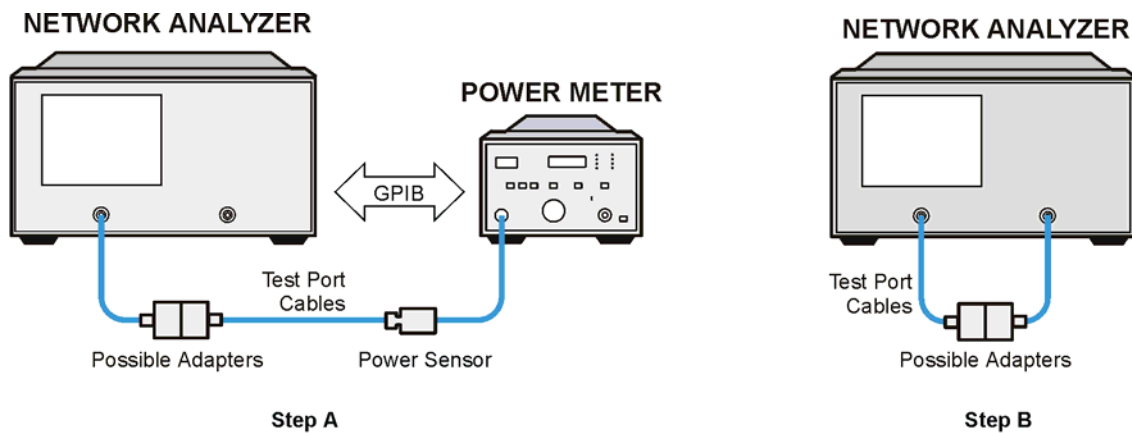

pa5163e

3. To choose a non-ratioed measurement, press:

Calibrating for Increased Measurement Accuracy

Frequency Response Error Corrections

Meas **INPUT PORTS** **B**

For ES analyzers, press **TEST PORTS 1**. This sets the source at PORT 1.

4. Set any other measurement parameters that you want for the device measurement: power, number of points, IF bandwidth.
5. To perform a receiver error correction, press:

Cal **CALIBRATE MENU** **RECEIVER CAL** **-10** **x1** **TAKE RCVR CAL SWEEP**

NOTE You can save or store the measurement correction to use for later measurements. Refer to [Chapter 4 , "Printing, Plotting, and Saving Measurement Results"](#) for procedures.

6. This completes the receiver calibration for transmission measurements. You can connect and measure your device under test.

NOTE The accuracy of the receiver calibration will be nearly the same as the test port power accuracy; and the test port power accuracy can be significantly improved by performing a power meter source calibration, as described later in ["Power Meter Measurement Calibration"](#) on page 6-33.

Calibrations at powers other than 0 dBm are possible. Receiver calibration normalizes the trace to the value set for the reference level. For example, to do a receiver calibration at -10 dBm, set the source to -10 dBm, set the reference level to -10 dBm, then perform the receiver calibration.

Frequency Response and Isolation Error Corrections

You can make a response and isolation correction for the following measurements:

- reflection measurements
- transmission measurements
- combined reflection and transmission measurements

NOTE Although you can perform a response and isolation correction for reflection measurements, we recommend that you perform an S_{11} one-port error correction; it is more accurate and just as convenient.

Response and Isolation Error Correction for Transmission Measurements

This procedure is intended for measurements that have a measurement range of greater than 90 dB.

1. Press **(Preset)**.
2. Select the type of measurement you want to make.
 - If you want to make a transmission measurement in the forward direction (S_{21}), press:
(Meas) Trans: FWD S21 (B/R) or on ET models: **TRANSMISSN**
 - For ES analyzers, if you want to make a transmission measurement in the reverse direction (S_{12}), press:
(Meas) Trans: REV S12 (A/R)
3. Set any other measurement parameters that you want for the device measurement: power, number of points, IF bandwidth.
4. To access the measurement correction menus, press:
(Cal)
5. If your calibration kit is different than the kit specified under the **CAL KIT []** softkey, press:
CAL KIT SELECT CAL KIT (select your type of kit) **RETURN**
If your type of calibration kit is not listed in the displayed menu, refer to ["Modifying Calibration Kits" on page 7-57](#).
6. To select a response and isolation correction and to start the response portion of the calibration, press:
CALIBRATE MENU RESPONSE & ISOL'N RESPONSE
7. Make a "thru" connection between the points where you will connect your device under test.

NOTE Include any adapters that you will have in the device measurement. That is, connect the standard device to the particular connector where you will connect your device under test.

Calibrating for Increased Measurement Accuracy Frequency Response and Isolation Error Corrections

8. To measure the standard, when the displayed trace has settled, press:

THRU

The analyzer displays **WAIT - MEASURING CAL STANDARD** during the standard measurement. The analyzer underlines the **THRU** softkey after it measures the calibration standard, and computes the error coefficients.

9. Connect impedance-matched loads to PORT 1 and PORT 2, as shown in [Figure 6-5](#). Include the adapters that you would include for your device measurement.

Figure 6-5 Standard Connections for a Response and Isolation Error Correction for Transmission Measurements

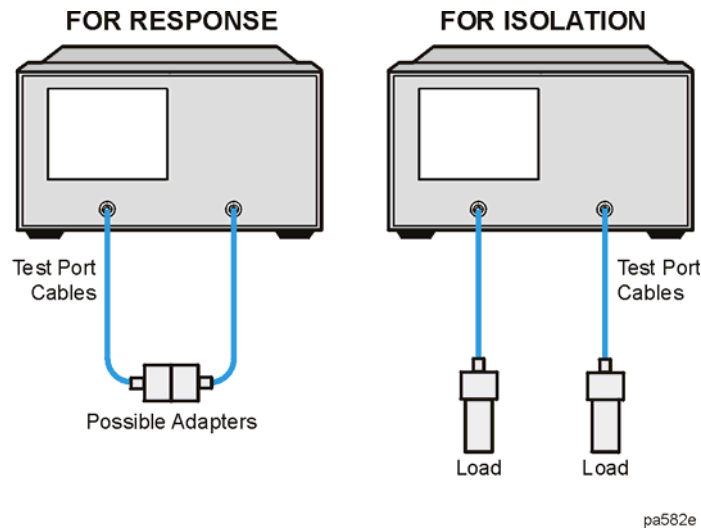

NOTE If you will be measuring highly reflective devices, such as filters, use the test device, connected to the reference plane and terminated with a load, for the isolation standard.

10. To help remove crosstalk noise, set the analyzer as follows:

- Press **(Avg)** **AVERAGING ON** **AVERAGING FACTOR** and enter at least four times more averages than desired during the device measurement.
- Press **(Cal)** **MORE** **ALTERNATE A and B** to eliminate one crosstalk path.

11. To measure the calibration standard, press:

(Cal) **RESUME CAL SEQUENCE** **ISOL'N STD**

12. Return the averaging to the original state of the measurement. For example, reduce the averaging factor by at least four times or turn averaging off.

13. To compute the isolation error coefficients, press:

(Cal) **RESUME CAL SEQUENCE** **DONE** **RESP ISOL'N CAL**

The analyzer displays the corrected data trace. The analyzer also shows the notation **Cor** at the left of the screen, indicating that the correction is switched on for this channel.

NOTE You can save or store the measurement correction to use for later measurements. Refer to [Chapter 4, "Printing, Plotting, and Saving Measurement Results"](#) for procedures.

14. This completes the response and isolation correction for transmission measurements. You can connect and measure your device under test.

Response and Isolation Error Correction for Reflection Measurements

The response and isolation error correction for reflection measurements provides the following benefits:

- removes frequency response of the test setup
- removes isolation in transmission measurements
- removes directivity in reflection measurements

To perform the response and isolation error correction for reflection measurements:

1. Press **Preset**.
2. Select the type of measurement you want to make.
 - If you want to make a reflection measurement on PORT 1 (in the forward direction, S_{11}), leave the instrument default setting.
 - For ES analyzers, if you want to make a reflection measurement on PORT 2 (in the reverse direction, S_{22}), press:
Meas Refl: REV S22 (B/R)
3. Set any other measurement parameters that you want for the device measurement: power, sweep type, number of points, IF bandwidth.
4. To access the measurement correction menus, press:
Cal

Calibrating for Increased Measurement Accuracy Frequency Response and Isolation Error Corrections

5. If your calibration kit is different than the kit specified under the **CAL KIT []** softkey, press:

CAL KIT **SELECT CAL KIT** (select your type of kit) **RETURN**

If your type of calibration kit is not listed in the displayed menu, refer to "[Modifying Calibration Kits](#)" on page 7-57.

6. To select a response and isolation correction and to start with the response portion of the calibration, press:

CALIBRATE MENU **RESPONSE & ISOL'N** **RESPONSE**

7. Connect the short or open calibration standard to the port you selected for the test port (PORT 1 for S_{11} or PORT 2 for S_{22} on ES analyzers).

NOTE Include any adapters that you will have in the device measurement. That is, connect the standard device to the particular connector where you will connect your device under test.

Figure 6-6 Standard Connections for a Response and Isolation Correction for Reflection Measurements

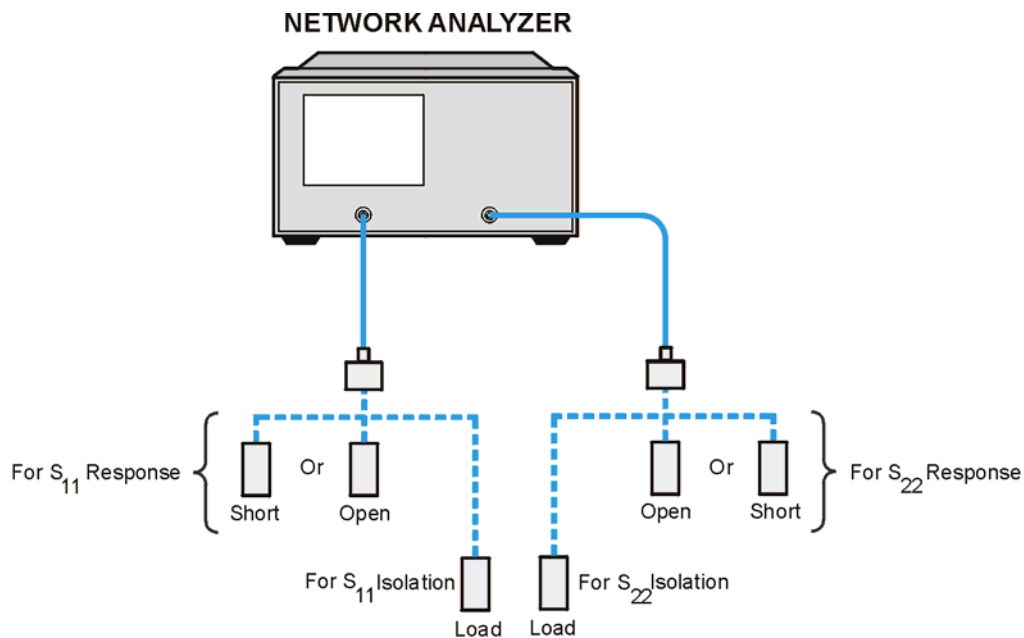

pa580e

8. To measure the standard, press:

SHORT or **OPEN**

If the calibration kit you selected has a choice between male and female calibration standards, remember to select the sex that applies to the test port and not the standard.

The analyzer displays `WAIT - MEASURING CAL STANDARD` during the standard measurement. The analyzer underlines the softkey that you selected after it finishes the measurement, and computes the error coefficients.

9. Connect the load calibration standard to the test port.
10. To measure the standard for the isolation portion of the correction, press **ISOL'N STD** .
 - a. Press **Avg** **AVERAGING ON** **AVERAGING FACTOR** and enter at least four times more averages than desired during the device measurement.
11. To compute the response and directivity error coefficients, press:

DONE RESP ISOL'N CAL

The analyzer displays the corrected S_{11} (or S_{22}) data. The analyzer also shows the notation `Cor` to the left of the screen, indicating that the correction is switched on for this channel.

NOTE You can save or store the error correction to use for later measurements. Refer to [Chapter 4](#) , “[Printing, Plotting, and Saving Measurement Results](#)” for procedures.

12. This completes the response and isolation error correction for reflection measurements. You can connect and measure your device under test.

Enhanced Frequency Response Error Correction

The enhanced frequency response error correction removes the following errors in the forward direction in ET models or in both the forward and reverse directions in ES models:

- removes directivity errors of the test setup
- removes source match errors of the test setup
- removes isolation errors of the test setup (optional)
- removes frequency response of the test setup

The enhanced reflection error correction may be used to remove load match from the test setup when measuring bilateral devices. Enhanced reflection terms are mathematically derived during all enhanced response calibrations but are not applied unless initiated by the **ENH. REFL. on OFF** softkey. Enhanced reflection correction is applied *after* the enhanced frequency response error correction is finished.

IMPORTANT Use enhanced reflection error correction only on bilateral devices. A bilateral device has similar forward and reverse transmission characteristics. Examples of bilateral devices are passive devices (filters, attenuators, and switches). Most active devices (amplifiers) and some passive devices (isolators and circulators) are not bilateral. If this error correction is used for a non-bilateral device, errors will occur in the resulting measurement.

1. Press **Preset**.
2. Select the type of measurement you want to make.
 - If you want to make measurements in the forward direction (S_{21} S_{11}), press:
Meas **Trans: FWD S21 (B/R)** or on ET models: **TRANSMISSN**
 - For ES analyzers, if you want to make measurements in the reverse direction (S_{12} S_{22}), press:
Meas **Trans: REV S12 (A/R)**
3. Set any measurement parameters that you want for the device measurement: power, format, number of points, or IF bandwidth.
4. To access the measurement correction menus, press:
Cal
5. If your calibration kit is different than the kit specified under the **CAL KIT []** softkey, press:
CAL KIT **SELECT CAL KIT** (select your type of kit) **RETURN**
If your type of calibration kit is not listed in the displayed menu, refer to ["Modifying Calibration Kits" on page 7-57](#).
6. To select the correction type, press **CALIBRATE MENU** **ENHANCED RESPONSE** and select the correction type.
 - If you want to make measurements in the forward direction, press:

S11/S21 ENH. RESP. or on ET models: **TRAN/REFL ENH. RESP.**

- For ES analyzers, if you want to make measurements in the reverse direction, press:

S22/S12 ENH. RESP.

7. Connect a shielded open circuit to PORT 1 (or PORT 2 for reverse measurements).

NOTE Include any adapters that you will have in the device measurement. That is, connect the standard to the particular connector where you will connect your device under test.

Figure 6-7 Standard Connections for Enhanced Response Calibration

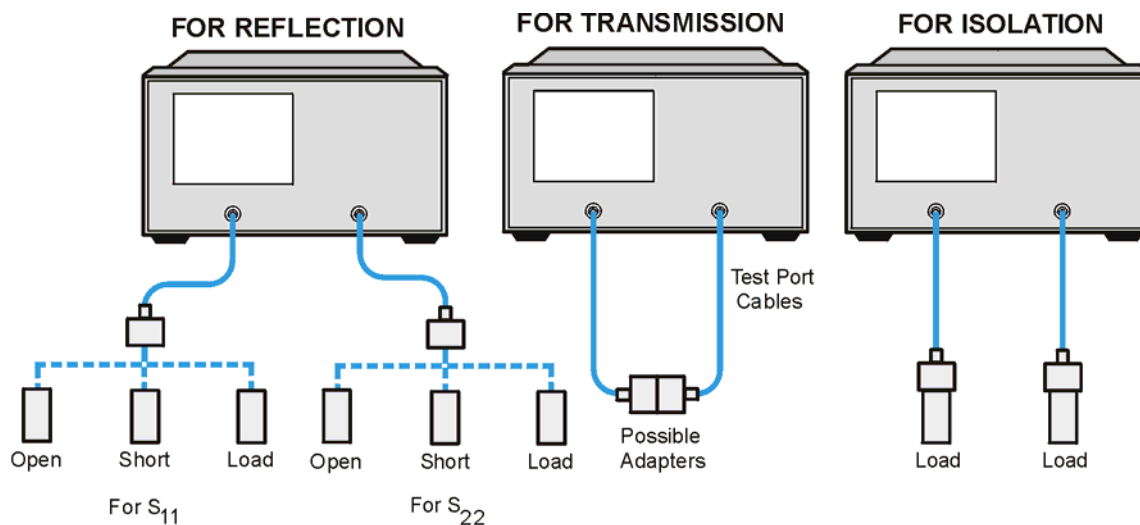

pa586e

8. To measure the standard, when the displayed trace has settled, press:

OPEN

The analyzer displays **WAIT - MEASURING CAL STANDARD** during the standard measurement. The analyzer underlines the **OPEN** softkey after it measures the standard.

9. Disconnect the open, and connect a short circuit to the test port.
10. To measure the device, when the displayed trace has settled, press:

SHORT

The analyzer measures the short circuit and underlines the **SHORT** softkey.

11. Disconnect the short, and connect an impedance-matched load to the test port.
12. To measure the standard, when the displayed trace has settled, press:

LOADS, select the type of load you are using, and then press **DONE: LOADS** when the analyzer has finished measuring the load.

Notice that the **LOADS** softkey is now underlined.

Calibrating for Increased Measurement Accuracy
Enhanced Frequency Response Error Correction

13. To compute the reflection correction coefficients, press **STANDARDS DONE**.
14. To start the transmission portion of the correction, press **TRANSMISSION**.
15. Make a "thru" connection between the points where you will connect your device under test as shown in Figure 6-7.

NOTE Include any adapters or cables that you will have in the device measurement. That is, connect the standard device where you will connect your device under test.

NOTE The thru in most calibration kits is defined with zero length. The correction will *not* work properly if a non-zero length thru is used, unless the calibration kit is modified to change the defined thru to the length used. This is important for measurements of non-insertable devices (devices having ports that are both male or both female). The modified calibration kit must be saved as the user calibration kit, and the **USER KIT** softkey must be selected before the calibration is started.

16. To measure the standard, when the trace has settled, press:

FWD TRANS THRU or **REV TRANS THRU**

FWD MATCH THRU or **REV MATCH THRU**

STANDARDS DONE

The analyzer underlines the softkey label after it makes each measurement.

17. Press **ISOLATION** and select from the following two options:

- If you will be measuring devices with a dynamic range less than 90 dB, press:

OMIT ISOLATION

- If you will be measuring devices with a dynamic range greater than 90 dB, follow these steps:

- a. Connect impedance-matched loads to the test ports. Include the adapters that you would include for your device measurement.

NOTE If you will be measuring highly reflective devices such as filters, use the test device, connected to the reference plane and terminated with a load, for the isolation standard.

- b. Activate at least four times more averages than desired during the device measurement.

- c. Press **Cal** **RESUME CAL SEQUENCE** **ISOLATION FWD or REV** **ISOL'N STD DONE**.

- d. Return the averaging to the original state of the measurement, and press **Cal** **RESUME CAL SEQUENCE**.

18. To compute the error coefficients, press **DONE ENH RESP CAL**.

The analyzer displays the corrected measurement trace. The analyzer also shows the notation **Cor** at

the left of the screen, indicating that error correction is on.

Enhanced Reflection Calibration

19. If you are measuring a bilateral device and want to remove the load match error, activate the enhanced reflection calibration by pressing:

ENHANCED RESPONSE

ENH. REFL. on OFF until ON is selected

NOTE You can save or store the measurement correction to use for later measurements. Refer to [Chapter 4, "Printing, Plotting, and Saving Measurement Results"](#) for procedures.

20. This completes the enhanced response correction procedure. You can connect and measure your device under test.

One-Port Reflection Error Correction

- removes directivity errors of the test setup
- removes source match errors of the test setup
- removes frequency response of the test setup

You can perform a 1-port correction for an S_{11} or an S_{22} measurement for ES analyzers. The only difference between the two procedures is the measurement parameter that you select.

NOTE This is the recommended error correction process for all reflection measurements, when full two-port correction or enhanced response calibration is not used.

1. Press **Preset**.
2. Select the type of measurement you want to make.
 - If you want to make a reflection measurement on PORT 1 (in the forward direction, S_{11}), leave the instrument default setting.
 - For ES analyzers, if you want to make a reflection measurement on PORT 2 (in the reverse direction, S_{22}), press:
Meas **Refl: REV S22 (B/R)**
3. Set any other measurement parameters that you want for the device measurement: power, number of points, IF bandwidth.
4. To access the measurement correction menus, press:
Cal
5. If your calibration kit is different than the kit specified under the **CAL KIT []** softkey, press:
CAL KIT **SELECT CAL KIT** (select your type of kit) **RETURN**
If your type of calibration kit is not listed in the displayed menu, refer to ["Modifying Calibration Kits" on page 7-57](#).
6. To select the correction type, press **CALIBRATE MENU** and select the correction type.
 - If you want to make a reflection measurement at PORT 1, press:
S11 1-PORT
 - For ES analyzers, if you want to make a reflection measurement at PORT 2, press:
S22 1-PORT
7. Connect a shielded open circuit to PORT 1 (or PORT 2 for an S_{22} measurement).

NOTE Include any adapters that you will have in the device measurement. That is, connect the calibration standard to the particular connector where you will connect your device under

test.

Figure 6-8 Standard Connections for a One Port Reflection Error Correction

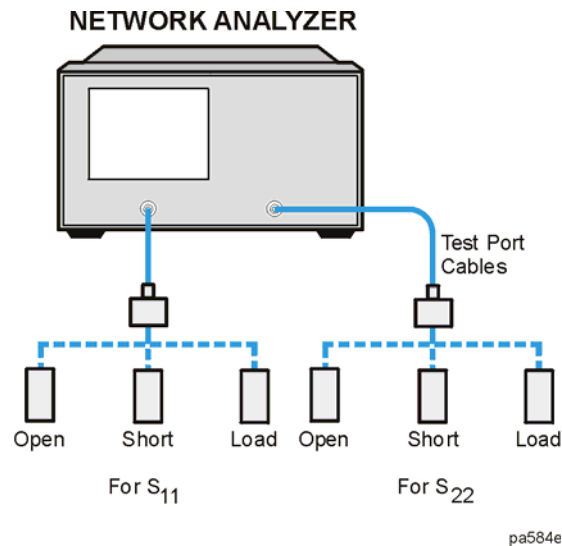

- To measure the standard, when the displayed trace has settled, press: **OPEN**

NOTE If the calibration kit that you selected has a choice between male or female calibration standards, remember to select the sex that applies to the test port and not the standard.

The analyzer displays **WAIT - MEASURING CAL STANDARD** during the standard measurement. The analyzer underlines the **OPEN** softkey after it measures the calibration standard.

- Disconnect the open, and connect a short circuit to the test port.

- To measure the standard when the displayed trace has settled, press:

SHORT

The analyzer measures the short circuit and underlines the **SHORT** softkey.

- Disconnect the short, and connect an impedance-matched load to the test port.

- When the displayed trace has settled, press:

LOADS, select the type of load you are using, and then press **DONE: LOADS** when the analyzer has finished measuring the load.

Notice that the **LOADS** softkey is now underlined.

- To compute the error coefficients, press:

DONE: 1-PORT CAL

The analyzer displays the corrected data trace. The analyzer also shows the notation **CO_R** to the left of the screen, indicating that the correction is switched on for this channel.

NOTE The open, short, and load could be measured in any order, and need not follow the order in

this example.

NOTE You can save or store the error correction to use for later measurements. Refer to [Chapter 4](#), “[Printing, Plotting, and Saving Measurement Results](#)” for procedures.

14. This completes the one-port correction for reflection measurements. You can connect and measure your device under test.

Full Two-Port Error Correction (ES Analyzers Only)

- removes directivity errors of the test setup in forward and reverse directions
- removes source match errors of the test setup in forward and reverse directions
- removes load match errors of the test setup in forward and reverse directions
- removes isolation errors of the test setup in forward and reverse directions (optional)
- removes frequency response of the test setup in forward and reverse directions

NOTE This is the most accurate error-correction procedure. Since the analyzer takes both forward and reverse sweeps to update one measurement trace, this procedure takes more time than the other correction procedures.

1. Set any measurement parameters that you want for the device measurement: power, format, number of points, or IF bandwidth.
2. To access the measurement correction menus, press:

Cal

3. If your calibration kit is different than the kit specified under the **CAL KIT []** softkey, press:

CAL KIT **SELECT CAL KIT** (select your type of kit) **RETURN**

If your type of calibration kit is not listed in the displayed menu, refer to ["Modifying Calibration Kits" on page 7-57](#).

4. To select the correction type, press:

CALIBRATE MENU **FULL 2-PORT** **REFLECTION**

5. Connect a shielded open circuit to PORT 1.

NOTE Include any adapters that you will have in the device measurement. That is, connect the standard to the particular connector where you will connect your DUT.

Figure 6-9 Standard Connections for Full Two-Port Error Correction

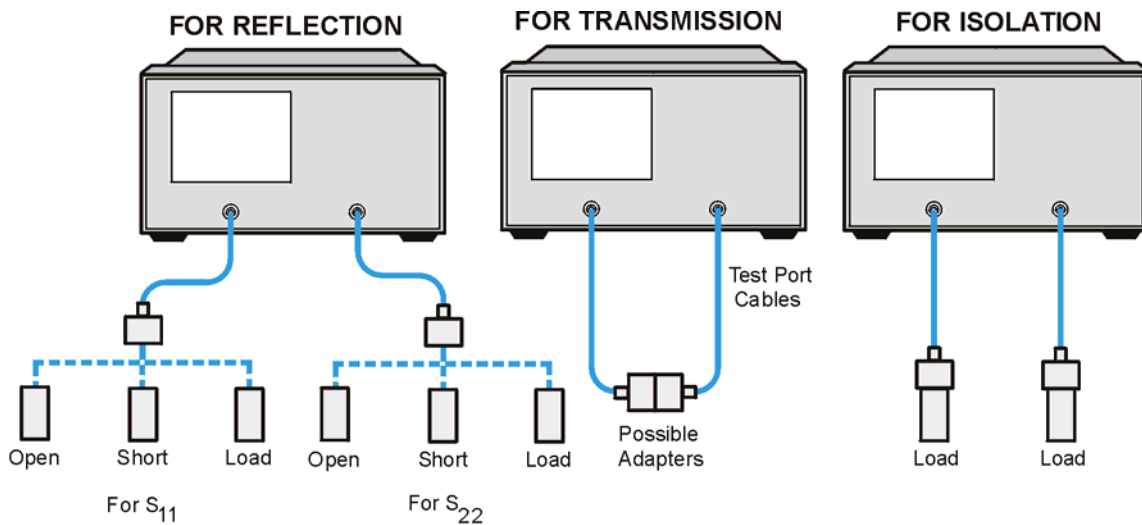

pa586e

- To measure the standard, when the displayed trace has settled, press:

FORWARD: OPEN

The analyzer displays **WAIT - MEASURING CAL STANDARD** during the standard measurement. The analyzer underlines the **OPEN** softkey after it measures the standard.

- Disconnect the open, and connect a short circuit to PORT 1.
- To measure the device, when the displayed trace has settled, press:

FORWARD: SHORT

The analyzer measures the short circuit and underlines the **SHORT** softkey.

- Disconnect the short, and connect an impedance-matched load to PORT 1.
- To measure the standard, when the displayed trace has settled, press:

FORWARD: LOAD, select the type of load you are using, and then press **DONE: LOADS** when the analyzer has finished measuring the load.

Notice that the **LOADS** softkey is now underlined.

- Repeat the open-short-load measurements described in the previous steps, but connect the devices in turn to PORT 2, and use the **REVERSE: OPEN**, **REVERSE: SHORT**, and **REVERSE: LOADS** softkeys. Include any adapters that you would include in your device measurement.
- To compute the reflection correction coefficients, press:

STANDARDS DONE

- To start the transmission portion of the correction, press **TRANSMISSION**.
- Make a "thru" connection between the points where you will connect your device under test as shown in [Figure 6-9](#).

NOTE Include any adapters or cables that you will have in the device measurement. That is, connect the standard device where you will connect your DUT.

NOTE The thru in most calibration kits is defined with zero length. The correction will *not* work properly if a non-zero length thru is used, unless the calibration kit is modified to change the defined thru to the length used. This is important for measurements of non-insertable devices (devices having ports that are both male or both female). The modified calibration kit must be saved as the user calibration kit, and **USER KIT** must be selected before the calibration is started.

15. To measure the standard, when the trace has settled, press:

DO BOTH FWD+REV

The analyzer underlines the softkey label after it makes each measurement.

16. Press **ISOLATION** and select from the following two options:

If you will be measuring devices with a dynamic range less than 90 dB, press:

OMIT ISOLATION

If you will be measuring devices with a dynamic range greater than 90 dB, follow these steps:

- a. Connect impedance-matched loads to PORT 1 and PORT 2. Include the adapters that you would include for your device measurement.

NOTE If you will be measuring highly reflective devices, such as filters, use the test device, connected to the reference plane and terminated with a load, for the isolation standard.

- b. Activate at least four times more averages than desired during the device measurement.

NOTE If loads can be connected to both port 1 and port 2 simultaneously, then the following step can be performed using the **DO BOTH FWD + REV** softkey.

- c. Press **Cal** **RESUME CAL SEQUENCE** **ISOLATION**
FWD ISOL'N ISOL'N STD **REV ISOL'N ISOL'N STD** **ISOLATION DONE**.
- d. Return the averaging to the original state of the measurement, and press **Cal**
RESUME CAL SEQUENCE.

Calibrating for Increased Measurement Accuracy
Full Two-Port Error Correction (ES Analyzers Only)

17. To compute the error coefficients, press:

DONE 2-PORT CAL

The analyzer displays the corrected measurement trace. The analyzer also shows the notation **Cor** at the left of the screen, indicating that error correction is on.

NOTE You can save or store the measurement correction to use for later measurements. Refer to [Chapter 4 , “Printing, Plotting, and Saving Measurement Results”](#) for procedures.

18. This completes the full two-port correction procedure. You can connect and measure your device under test.

Power Meter Measurement Calibration

A GPIB-compatible power meter can monitor and correct RF source power to achieve leveled power at the test port. During a power meter calibration, the power meter samples the power at each measurement point across the frequency band of interest. The analyzer then constructs a correction data table to correct the power output of the internal source. The correction table may be saved in an instrument state register with the SAVE key.

The correction table may be updated on each sweep (in a leveling application) or during an initial single sweep. In the sample-and-sweep mode the power meter is not needed for subsequent sweeps. The correction table may be read or modified through GPIB.

Power meter calibration is useful for the following applications:

- when you are testing a system with significant frequency response errors (for example, a coupler with significant roll-off, or a long cable with a significant amount of loss)
- when you are measuring devices that are very sensitive to actual input power for proper operation
- when you require a reference for receiver power calibration

The power meter can measure and correct power in two ways:

- continuous correction—each sweep mode
- sample-and-sweep correction—single sweep mode

The time required to perform a power meter calibration depends on the source power, number of points tested, and number of readings taken. Refer to the “Specifications and Characteristics” chapter of the reference guide for characteristic power meter calibration sweep speeds and accuracy.

Regardless of the measurement application, the analyzer's source can only supply corrected power within the selected power range. If power outside this range is requested, the annotation will change to PC?.

Loss of Power Meter Calibration Data

The power meter calibration data will be lost by committing any of the following actions:

Turning power off. Turning off the instrument erases the power meter calibration table.

Changing sweep type. If the sweep type is changed (linear, log, list, CW, power) while power meter calibration is on, the calibration data will be lost. However, calibration data is retained if you change the sweep type while power meter calibration is off.

Changing frequency. Power meter calibration data will also be lost if the frequency is changed in log or list mode, but it is retained in linear sweep mode.

Pressing Preset. Presetting the instrument will erase power meter calibration data. If the instrument state has been saved in a register using the Save/Recall key, you may recall the instrument state and the data will be restored. Saving the instrument state will not protect the data if the instrument is turned off.

Interpolation in Power Meter Calibration

If the frequency is changed in linear sweep, or the start/stop power is changed in power sweep, then the calibration data is interpolated for the new range.

If calibration power is changed in any of the sweep types, the values in the power setting array are increased or decreased to reflect the new power level. Some accuracy is lost when this occurs.

Entering the Power Sensor Calibration Data

Entering the power sensor calibration data compensates for the frequency response of the power sensor, thus ensuring the accuracy of power meter calibration.

1. Make sure that your analyzer and power meter are configured. Refer to the “Options and Accessories” chapter of the reference guide for configuration procedures.
2. Press **Cal** **PWRMTR CAL** **LOSS/SENSR LISTS** **CAL FACTOR SENSOR A** .
The analyzer shows the notation **EMPTY**, if you have not entered any segment information.
3. To create the first segment, press:
ADD **FREQUENCY**
4. Enter the frequency of a correction factor data point, as listed on the power sensor, followed by the appropriate key: **G/n** **M/μ** **k/m** .
5. Press **CAL FACTOR** and enter the correction factor that corresponds to the frequency that you have entered in the previous step. Complete the correction factor entry by pressing **x1** **DONE** .
6. Repeat the previous three steps to enter up to 55 frequency segments.

You may enter multiple segments in any order because the analyzer automatically sorts them and lists them on the display by frequency value. The analyzer also automatically interpolates the values between correction factor data points.

If you only enter one frequency segment, the analyzer assumes that the single value is valid over the entire frequency range of the correction.

7. After you have entered all the frequency segments, press **DONE** .

Editing Frequency Segments

1. Access the Segment Modify menu by pressing **Cal** **PWRMTR CAL** **LOSS/SENSR LISTS** **CAL FACTOR SENSOR A** (or **CAL FACTOR SENSOR B** , depending on where the segment is that you want to edit).
2. Identify the segment that you want to edit by pressing **SEGMENT** and using the **↑** and **↓** keys to locate and position the segment next to the pointer (>), shown on the display. Or press **SEGMENT** and enter the segment number followed by **x1** .
3. Press **EDIT** and then press either the **FREQUENCY** or **CAL FACTOR** key, depending on which part of the segment you want to edit.
 - If you are modifying the frequency, enter the new value, followed by a **G/n** , **M/μ** , or **k/m** key.
 - If you are modifying the correction factor, enter the new value, followed by the **x1** key.
4. Press **DONE** after you have finished modifying the segment.
5. If you want to edit any other segments, press **SEGMENT** and follow the previous steps, starting with step 2.

Deleting Frequency Segments

1. Access the Segment Modify menu by pressing **Cal** **PWRMTR CAL** **LOSS/SENSR LISTS** **CAL FACTOR SENSOR A** (or **CAL FACTOR SENSOR B**, depending on where the segment is that you want to delete).
2. Identify the segment that you want to delete by pressing **SEGMENT** and using the **↑** and **↓** keys to locate and position the segment next to the pointer (>), shown on the display. Or press **SEGMENT** and enter the segment number followed by **x1**.
3. Press **DELETE**.
The analyzer deletes the segment and moves the remainder of the segments up one number.
4. You could also delete all the segments in a list by pressing **CLEAR LIST** **YES**.
5. Press **DONE** when you are finished modifying the segment list.

Compensating for Directional Coupler Response

If you use a directional coupler to sample power in your measurement configuration, you should enter the coupled arm power loss value into the power loss table, using the following procedure. You can enter the loss information in a single segment, and the analyzer will assume that the value applies to the entire frequency range of the instrument. Or, you can input actual measured power loss values at several frequencies using up to 12 segments, enhancing power accuracy.

1. Press **Cal** **PWRMTR CAL** **LOSS/SENSR LISTS** **POWER LOSS**.
The analyzer shows the notation **EMPTY**, if you have not entered any segment information.
2. To create the first segment, press **ADD** **FREQUENCY** and enter a frequency of a correction factor data point, followed by the appropriate key: **G/n** **M/μ** **k/m**.
3. Press **LOSS** and enter the power loss that corresponds to the attenuation of the directional coupler (or power splitter) at the frequency that you have entered in the previous step. Complete the power loss entry by pressing **x1** **DONE**.

NOTE Remember to subtract the through arm loss from the coupler arm loss before entering it into the power loss table, to ensure the correct power at the output of the coupler.

- Repeat the previous two steps to enter up to 12 frequency segments, depending on the required accuracy.

You may enter multiple segments in any order because the analyzer automatically sorts them and lists them on the display in increasing order of frequency.

If you only enter one frequency segment, the analyzer assumes that the single value is valid over the entire frequency range of the correction.

- After you have entered all the segments, press **DONE**.
- Press **Cal** **PWRMTR CAL** **PWR LOSS ON** to activate the power loss compensation.

Using Sample-and-Sweep Correction Mode

You can use the sample-and-sweep mode to correct the analyzer output power and update the power meter correction data table, during the initial measurement sweep. Because the analyzer measures the actual power at each frequency point during the initial sweep, the initial sweep time is significant. However, in this mode of operation the analyzer does not require the power meter for subsequent sweeps. Therefore, this mode sweeps considerably faster than the continuous correction mode.

Figure 6-10 Sample-and-Sweep Mode for Power Meter Calibration

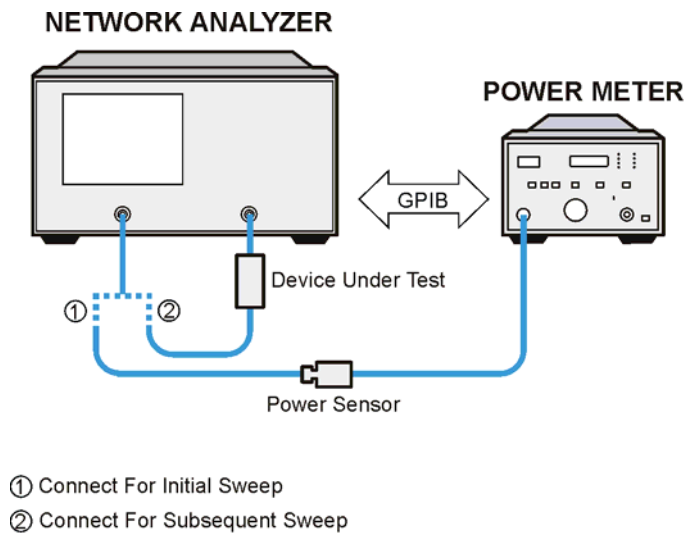

pa590e

- Calibrate and zero the power meter.
- Connect the equipment as shown in [Figure 6-10](#).

3. Select the analyzer as the system controller:

Local

SYSTEM CONTROLLER

4. Set the power meter's address ("XX" represents the address in the following keystrokes):

SET ADDRESSES

ADDRESS: P MTR/GPIB **XX** **x1**

5. Select the appropriate power meter by pressing **POWER MTR []** until the correct model number is displayed (436A or 438A/437).

NOTE The E4418B and E4419B power meters have a "437 emulation" mode. This allows these power meters, with an HP/Agilent 848X-series power sensor, to be used with the network analyzer. In this step, when selecting a power meter, choose the 438A/437 selection.

6. Set test port power to the approximate desired corrected power.
7. Press **Cal** **PWRMTR CAL** and enter the test port power level that you want at the input to your test device. For example, if you enter **-10** **x1**, the display will read **CAL POWER -10**.
8. If you want the analyzer to make more than one power measurement at each frequency data point, press:
NUMBER OF READINGS **n** **x1**, (where n = the number of desired iterations).
If you increase the number of readings, the power meter correction time will substantially increase.
9. Press **Cal** **PWRMTR CAL** **ONE SWEEP** **TAKE CAL SWEEP**.

NOTE Because power meter calibration requires a longer sweep time, you may want to reduce the number of points before pressing **TAKE CAL SWEEP**. After the power meter calibration is finished, return the number of points to its original value and the analyzer will automatically interpolate this calibration. Some accuracy will be lost for the interpolated points.

The analyzer will use the data table for subsequent sweeps to correct the output power level at each measurement point. Also, the status annunciator **PC** will appear on the analyzer display.

NOTE You can abort the calibration sweep by pressing **PWRMTR CAL OFF**.

10. Remove the power sensor from the analyzer test port and connect your test device.

Using Continuous Correction Mode

You can set the analyzer to update the correction table at each sweep (as in a leveling application), using the continuous sample mode. When the analyzer is in this mode, it continuously checks power at every point in

each sweep. You must keep the power meter connected as shown in Figure 6-11. This mode is also known as power meter leveling, and the speed is limited by the power meter.

NOTE You may level at the input of a device under test, using a 2-resistor power splitter or a directional coupler before the device; or level at the output of the device using a 3-resistor power splitter or a bidirectional coupler after the device.

Figure 6-11 Continuous Correction Mode for Power Meter Calibration

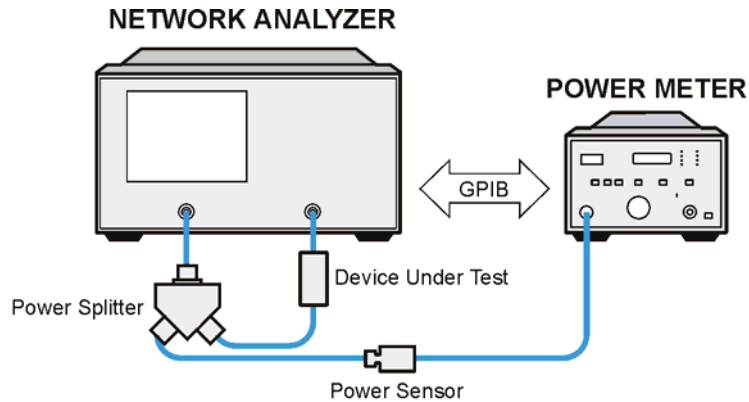

pa588e

1. Connect a power splitter or directional coupler to the port supplying RF power to your test device, as shown in Figure 6-11.
2. Set test port power to approximate desired leveled power.
3. Press **Cal** **PWRMTR CAL** and enter the test port power level that you want the analyzer to maintain at the input to your test device. Compensate for the power loss of the power splitter or directional coupler in the setup.
4. If you want the analyzer to make more than one power measurement at each frequency data point, press **NUMBER OF READINGS** **(n)** **(x1)** (where n = the number of desired iterations).
If you increase the number of readings, the power meter correction time will substantially increase.
5. Press **Cal** **PWRMTR CAL** **EACH SWEEP** **TAKE CAL SWEEP** to activate the power meter correction.

To Calibrate the Analyzer Receiver to Measure Absolute Power

You can use the power meter calibration as a reference to calibrate the analyzer receiver to accurately measure absolute power. The following procedure shows you how to calibrate the receiver to any power level.

1. Set the analyzer test port power to the desired level:

Power (enter power level) **x1**

2. Connect the power sensor to the analyzer test port 1.
3. To apply the one sweep mode, press:

Cal **PWRMTR CAL** (enter power level) **x1** **ONE SWEEP** **TAKE CAL SWEEP**

NOTE Because power meter calibration requires a longer sweep time, you may want to reduce the number of points before pressing **TAKE CAL SWEEP**. After the power meter calibration is finished, return the number of points to its original value and the analyzer will automatically interpolate this calibration.

The status notation **PC** will appear on the analyzer display. Port 1 is now a calibrated source of power.

4. Connect the test port 1 output to the test port 2 input.
5. Choose a non-ratioed measurement by pressing:

Meas **INPUT PORTS** **B** **TEST PORT 1**

This sets the source at PORT 1, and the measurement receiver to PORT 2, or input port B.

6. To perform a receiver error correction, press:

Cal **CALIBRATE MENU** **RECEIVER CAL** (enter power level) **x1**
TAKE RCVR CAL SWEEP

The receiver channel now measures power to a characteristic accuracy of 0.35 dB or better. The accuracy depends on the match of the power meter, the source, and the receiver.

Calibrating for Noninsertable Devices

A test device that cannot be connected directly into a transmission test configuration is considered to be *noninsertable*.

Some examples of *noninsertable* test devices are:

- a fixture with two female SMA connectors, or a cable with two male type-N connectors.
- an adapter with SMA male and type-N female (or any combination connector type and sex).

Therefore, one of the following calibration methods must be performed:

- adapter removal (ES analyzers only)
- matched adapters
- modify the cal kit thru definition

Figure 6-12 Noninsertable Device

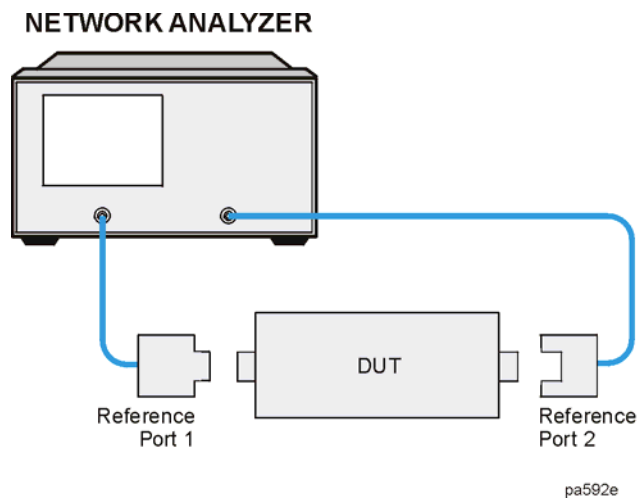

Adapter Removal Calibration (ES Analyzers Only)

Adapter removal calibration provides the most complete and accurate procedure for measuring noninsertable devices.

The following adapters are needed:

- Adapter A1, which mates with port 1 of the device, must be installed on test set port 1.
- Adapter A2, which mates with port 2 of the device, must be installed on test set port 2.
- Adapter A3 must match the connectors on the device under test (DUT).

NOTE Adapter A1 and Adapter A2 become part of the test setup to allow connection to the DUT. Adapter A3 is used during calibration only. Its effects will be removed.

Figure 6-13 Adapters Needed

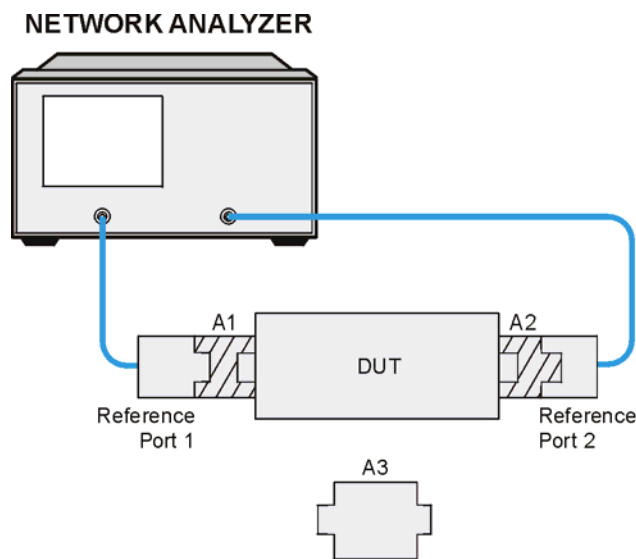

pa594e

Other requirements include:

- Calibration standards for performing a 2-port error correction for each connector type. Only recognized cal kit standards are available. SSMA, SMX, GPO and similar connectors have no recognized traceable cal kit standards.
- Specified electrical length of adapter A3 within $\pm 1/4$ wavelength for the measurement frequency range.

For each port, a separate 2-port error correction is performed, the first at the connection between A1 and A3, and the second at the connection between A2 and A3. The error coefficients are stored in separate calibration sets. After these calibrations, the two calibration sets are combined and, with knowledge of the electrical length of the adapter A3, a separate third calibration set is created. This cal set contains error coefficients that accurately represent the characteristics of Port 1 and Port 2, as if A1 and A2 were actually connected together to measure forward and reverse match and tracking terms.

Perform the 2-Port Error Corrections

1. Check the firmware to see if your revision supports adapter removal calibration by pressing:

Cal **MORE** **ADAPTER REMOVAL** **HELP ADAPT REMOVAL**

2. Determine the delay of adapter A3.
 - a. Refer to [Figure 6-14](#) while performing the steps in this procedure. Also refer to [page 6-41](#) for an explanation of A1, A2, and A3.
 - b. Perform a 1-port calibration at "Reference Port 1". Refer to Step A of [Figure 6-14](#).

Figure 6-14 Determining the Electrical Delay Setup

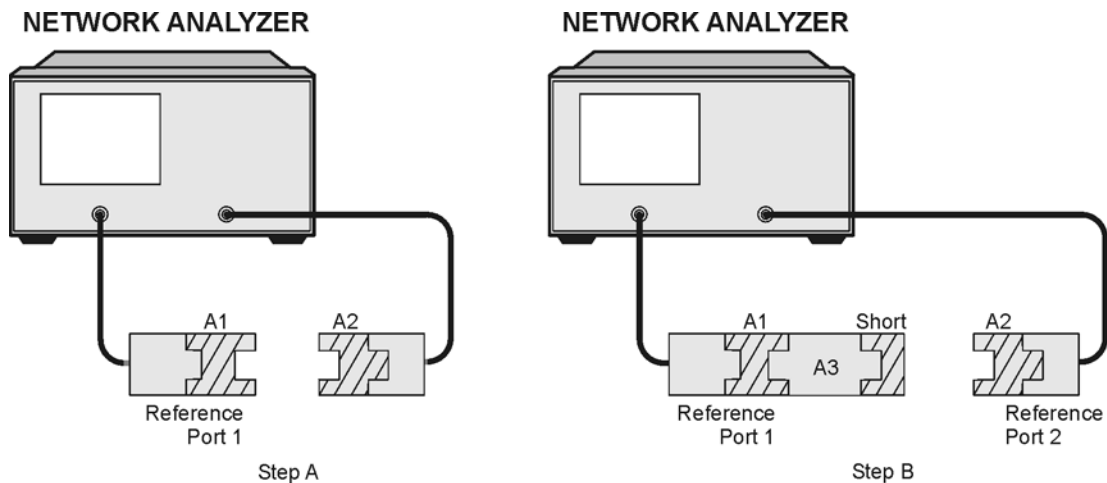

pl511ets

- c. Connect the A3 adapter to "Reference Port 1" as shown in Step B of [Figure 6-14](#). Attach the short (from the calibration kit for port 2) to the other end of the adapter.

You must know the delay of the short. The delay of the short can be found in the calibration kit that you are using. Typical delays of shorts are 31.7 ps for the short from the 85052D calibration kit and 31.8 ps for the short from the 85033D calibration kit.

- d. Measure the delay of the adapter and short together by pressing **Format** **DELAY**.
- e. Divide the resulting delay measurement by 2 to determine the delay of the thru and the short in one direction.
- f. Subtract the offset delay of the short (determined in step c) from the delay of the thru and the short in one direction (determined in step e). The result is the electrical delay of the thru. This value is used in the Step 12.
- g. Remove the short from the adapter.

NOTE You must use the floppy disk to store the following calibrations. Select the floppy disk by pressing **Save/Recall** **SELECT DISK** **INTERNAL DISK** .

3. Connect adapter A3 (same sex and connector type as the DUT) to adapter A2 on port 2 as shown in Figure 6-15.

Figure 6-15 Two-Port Cal Set 1

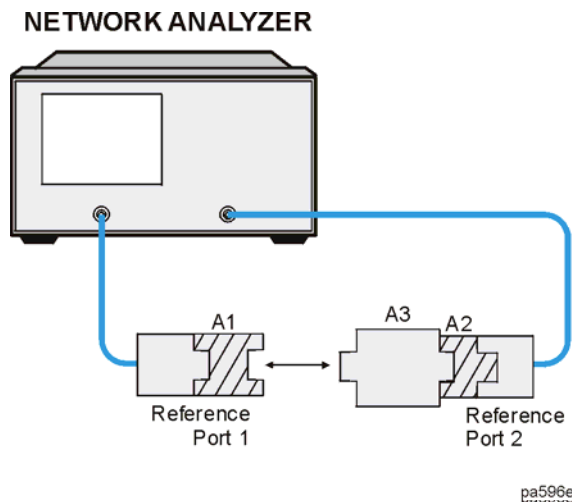

4. Perform a full 2-port calibration between ports 1 and 2 using calibration standards appropriate for the connector type at port 1 (the connector type for adapter A1). Save the calibration by selecting **Save/Recall** **SAVE STATE** . Name the file "PORT1."
5. Connect adapter A3 to adapter A1 on port 1 as shown in Figure 6-16.

Figure 6-16 Two-Port Cal Set 2

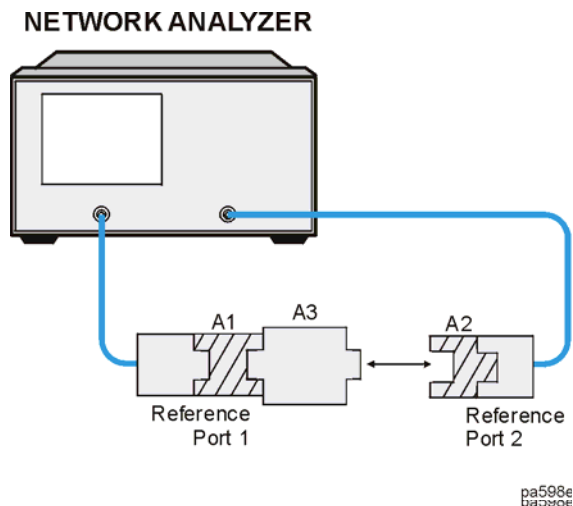

Calibrating for Increased Measurement Accuracy
Calibrating for Noninsertable Devices

6. Perform a full 2-port calibration between ports 1 and 2 using calibration standards appropriate for the connector type at port 2 (the connector type for adapter A2). Save the calibration by selecting **Save/Recall** **SAVE STATE** . Name the file "PORT2."

NOTE In the following steps, calibration data is recalled, not instrument states.

7. Press **Cal** **MORE** **ADAPTER REMOVAL** **RECALL CAL SETS** .
8. Turn the knob to select the file that contains the port 1 calibration data (where adapter A3 was on port 2).
9. Press **RECALL CAL PORT 1** .
10. Turn the knob to select the file that contains the port 1 calibration data (where adapter A3 was on port 1).
11. Press **RECALL CAL PORT 2** **RETURN** .
12. Press **ADAPTER DELAY** . Enter the delay value of the adapter from step 2f. Select the appropriate type: **ADAPTER COAX** or **ADAPTER WAVEGUIDE** .
13. Press **REMOVE ADAPTER** to complete the technique for calculating the new coefficients and overwrite the current active calibration set in use.

This process uses up an internal memory register. The calibration in this register is *not* the calibration created by adapter removal, rather it is a "scratch" calibration. You may wish to delete the register, or re-save the new calibration in this register (step 14).

14. Press **Save/Recall** **SELECT DISK** **INTERNAL MEMORY** **RETURN** and **SAVE STATE** . You can now remove the adapter from the test setup and insert the DUT.

Figure 6-17 Calibrated Measurement

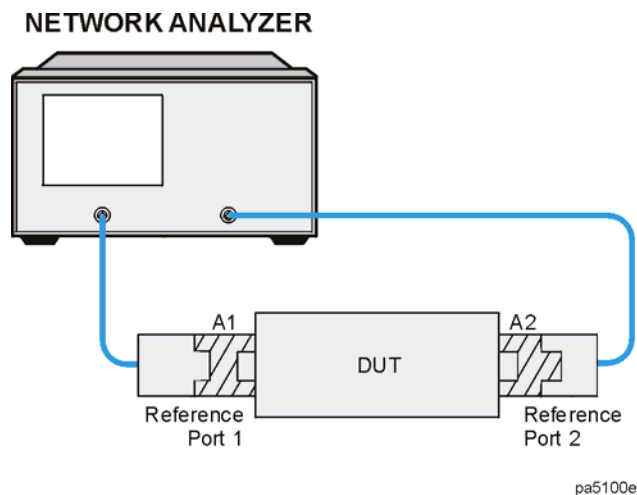

Verify the Results

Since the effect of the adapter has been removed, it is easy to verify the accuracy of the technique by simply measuring the adapter itself. Because the adapter was used during the creation of the two cal sets, and the technique removes its effects, measurement of the adapter itself should show the S-parameters.

If unexpected phase variations are observed, this indicates that the electrical delay of the adapter was not specified within a quarter wavelength over the frequency range of interest. To correct this, recall both cal sets, since the data was previously stored to disk, change the adapter delay, and press

REMOVE ADAPTER

Your analyzer's programmer's guide contains an example program that demonstrates the adapter removal process over GPIB.

Matched Adapters

With this method, you use two precision matched adapters which are "equal." To be equal, the adapters must have the same match, Z_0 , insertion loss, and electrical delay. The adapters in most Agilent calibration kits have matched electrical length, even if the physical lengths appear different.

Figure 6-18 Calibrating for Noninsertable Devices

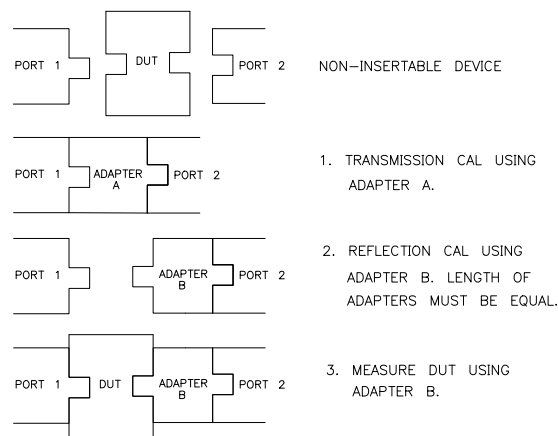

pg6136d

To use this method, refer to [Figure 6-18](#) and perform the following steps:

1. Perform a transmission calibration using the first adapter.
2. Remove adapter A, and place adapter B on port 2. Adapter B becomes the effective test port.
3. Perform a reflection calibration.
4. Measure the test device with adapter B in place.

The errors remaining after calibration with this method are equal to the differences between the two adapters that are used.

Modify the Cal Kit Thru Definition

With this method, it is only necessary to use a thru adapter. The calibration kit thru definition is modified to compensate for the adapter and then saved as a user kit. However, the electrical delay of the adapter must first be found. The adapter match will degrade the effective load match terms on both ports as well as degrade the transmission frequency response (tracking).

1. Refer to [Figure 6-19](#) while performing the steps in this procedure. Also refer to [page 6-41](#) for an explanation of A1, A2, and A3.
2. Perform a 1-port calibration at "Reference Port 1". Refer to Step A of [Figure 6-19](#).

Figure 6-19 Determining the Electrical Delay Setup

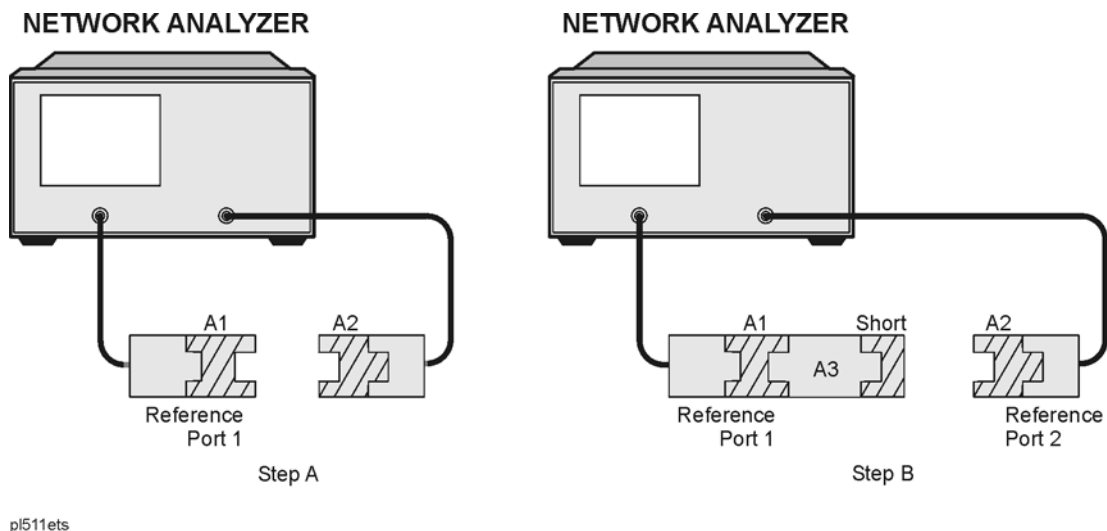

3. Connect the A3 adapter to "Reference Port 1" as shown in Step B of [Figure 6-19](#). Connect a short to the open end of the A3 adapter.
4. Measure the delay of the adapter by pressing **Format** **DELAY**.
5. Divide the resulting delay measurement by 2 to determine the delay of the thru and the short in one direction.
6. Determine the offset delay of the calibration short by examining the define standard menu (see ["Define Standard Menus"](#) on [page 7-59](#)).
7. Subtract the offset delay of the short (determined in step 6) from the delay of the thru and the short in one direction (determined in step 5). The result is electrical delay of the thru. This value is used in the next step.
8. Modify the calibration kit thru definition by entering in the electrical delay of adapter A3. Save this as a user kit.

For example, if A3 has 100 ps of delay, press:

Cal **CAL KIT** **MODIFY** **DEFINE STANDARD** **4** **x1**
MODIFY STD DEFINITION **SPECIFY OFFSET** **OFFSET DELAY** **0.100** **G/n**
STD DONE (DEFINED) **RETURN** **KIT DONE (MODIFIED)** **SAVE USER KIT**

9. Perform the desired calibration with this new user kit.
10. Connect the test device as shown in [Figure 6-17](#) and measure the device.

Minimizing Error When Using Adapters

To minimize the error introduced when you add an adapter to a measurement system, the adapter needs to have low SWR or mismatch, low loss, and high repeatability.

Figure 6-20 Adapter Considerations

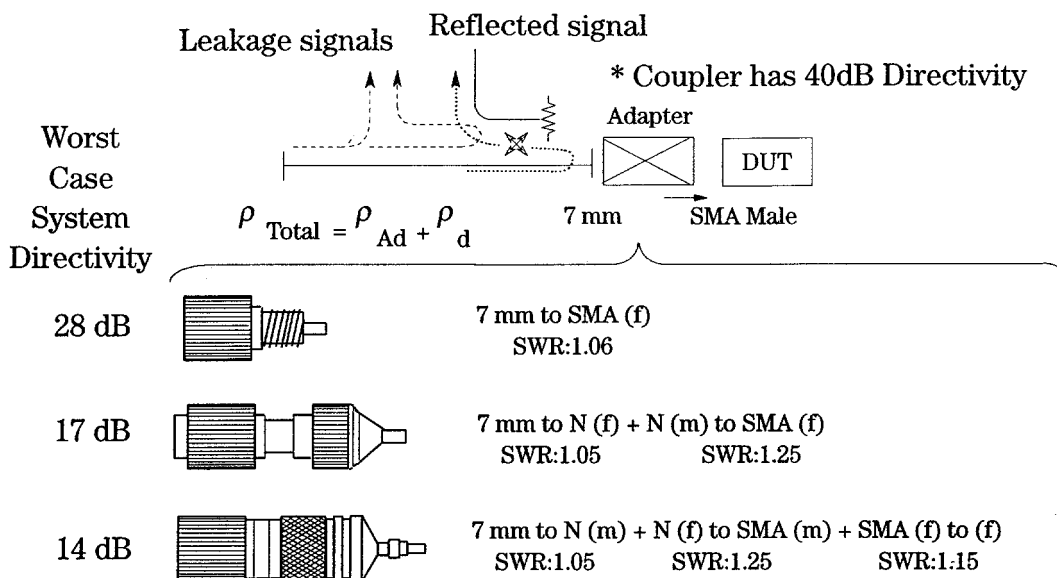

pg6237

In a reflection measurement, the directivity of a system is a measure of the error introduced by an imperfect signal separation device. It typically includes any signal that is detected at the coupled port which has not been reflected by the test device. This directivity error will add with the true reflected signal from the device, causing an error in the measured data. Overall directivity is the limit to which a device's return loss or reflection can be measured. Therefore, it is important to have good directivity to measure low reflection devices.

For example, a coupler has a 7 mm connector and 40 dB directivity, which is equivalent to a reflection coefficient of $\rho = 0.01$ directivity in dB = $-20 \log(\rho)$. Suppose we want to connect to a device with an SMA male connector. We need to adapt from 7 mm to SMA.

If we choose a precision 7 mm to SMA adapter with a SWR of 1.06, which has $\rho=0.03$, the overall directivity becomes $\rho=0.04$ or 28 dB. However, if we use two adapters to do the same job, the reflection from each adapter adds up to degrade the directivity to 17 dB. The last example, shown in [Figure 6-20](#), uses three adapters that shows an even worse directivity of 14 dB. It is clear that a low SWR is desirable to avoid degrading the directivity of the system.

Making Non-Coaxial Measurements

Non-coaxial, on-wafer measurements present a unique set of challenges for error correction in the analyzer:

- The close spacing between the microwave probes makes it difficult to maintain a high degree of isolation between the input and the output.
- The type of device measured on-wafer is often not always a simple two-port.
- It may be difficult to make repeatable on-wafer contacts due to the size of the device contact pads.

The capability of making non-coaxial measurements is available with TRL (thru-reflect-line) or LRM (line-reflect-match) calibration. For in-depth information on TRL/LRM calibration, refer to "[Calibrating for Non-Coaxial Devices \(ES Analyzers Only\)](#)" on page 6-50.

Due to the simplicity of the calibration standards, TRL or LRM calibrations may be used for non-coaxial applications such as on-wafer measurements. This type of calibration with time-domain gating and a variety of probe styles can provide optimal accuracy in on-wafer measurements.

NOTE Full TRL/LRM calibration is available on instruments equipped with Option 400, four sampler test set. TRL*/LRM* is available on standard instruments.

Fixtures

Fixtures are needed to interface non-coaxial devices to coaxial test instruments. It may also be necessary to transform the characteristic impedance from standard 50 Ω instruments to a non-standard impedance and to apply bias if an active device is being measured.

For accurate measurements, the fixture must introduce minimum change to the test signal, not destroy the test device, and provide a repeatable connection to the device.

For information about test fixtures for your measurement systems, ask for literature number 5962-9723E or contact: Inter-Continental Microwave, 1515 Wyatt Drive, Santa Clara, CA 95054, USA (Web site: <http://www.icmicrowave.com>).

If You Want to Design Your Own Fixture

Ideally, a fixture should provide a transparent connection between the test instrument and the test device. This means it should have no loss or electrical length and a flat frequency response, to prevent distortion of the actual signal. A perfect match to both the instrument and the test device eliminates reflected test signals. The signal should be effectively coupled into the test device, rather than leaking around the device and resulting in crosstalk from input to output. Repeatable connections are necessary to ensure consistent data.

Realistically, it is impossible to build an ideal fixture, especially at high frequencies. However, it is possible to optimize the performance of the test fixture relative to the performance of the test device. If the fixture's effects on the test signal are relatively small compared to the device's parameters, then the fixture's effects can be assumed to be negligible.

For example, if the fixture's loss is much less than the acceptable measurement uncertainty at the test frequency, then it can be ignored.

For additional information about fixtures, refer to Agilent Technologies Application Note 1287-9, "In-Fixture Measurements Using Vector Network Analyzers," literature number 5968-5329E.

Calibrating for Non-Coaxial Devices (ES Analyzers Only)

The analyzer has the capability of making calibrations using the TRL*/LRM* method. TRL* and LRM* are implementations of the thru-reflect-line and line-reflect-match calibrations, modified for the three-sampler receiver architecture in the analyzer. TRL/LRM calibration is available in analyzers with Option 400, which adds a fourth sampler to the receiver. The following procedures apply to both TRL*/LRM* and TRL/LRM calibrations.

TRL Error Correction

Create a User-Defined TRL Calibration Kit

In order to use the TRL technique, the calibration standards characteristics must be entered into the analyzer's user defined calibration kit.

The following steps show you how to define a calibration kit to utilize a set of TRL (THRU, REFLECT, LINE) standards. This example TRL kit contains the following:

- zero length THRU
- "flush" short for the REFLECT standard (0 second offset)
- 50 ohm transmission line with 80 ps of offset delay for the LINE

Modify the Standard Definitions

1. Press the following keys to start modifying the standard definitions:

Preset **Cal** **CAL KIT** **MODIFY** **DEFINE STANDARD**

2. To select a short, press **1** **x1**. (In this example, the **REFLECT** standard is a **SHORT**.)

3. Press the following keys:

SHORT **MODIFY STD DEFINITION** **SPECIFY OFFSET** **OFFSET DELAY** **0**
x1 **STD OFFSET DONE** **STD DONE (DEFINED)**

4. To define the THRU/LINE standard, press:

DEFINE STANDARD **4** **x1** **DELAY/THRU** **MODIFY STD DEFINITION**
SPECIFY OFFSET **OFFSET DELAY** **0** **x1** **STD OFFSET DONE**
STD DONE (DEFINED)

5. To define the LINE/MATCH standard, press:

DEFINE STANDARD **6** **x1** **DELAY/THRU** **MODIFY STD DEFINITION**
SPECIFY OFFSET **OFFSET DELAY** **.08** **G/n** **MAXIMUM FREQUENCY**

Enter a frequency greater than the maximum frequency range of the analyzer. For example, press **50** **G/n**. Then, press **STD OFFSET DONE**.

6. For the purposes of this example, change the name of the standard by pressing: **LABEL STD** and modifying the name to "LINE."

7. When the title area shows the new label, press:

DONE **STD DONE (DEFINED)**

Assign the Standards to the Various TRL Classes

8. To assign the calibration standards to the various TRL calibration classes, press:

Cal **CAL KIT** **MODIFY** **SPECIFY CLASS** **MORE** **MORE** **TRL REFLECT**

9. Since you previously designated standard #1 for the REFLECT standard, press:

1 **x1**

10. Since you previously designated standard #6 for the LINE/MATCH standard, press:

TRL LINE OR MATCH **6** **x1**

11. Since you previously designated standard #4 for the THRU/LINE standard, press:

TRL THRU **4** **x1**

12. To complete the specification of class assignments, press:

SPECIFY CLASS DONE

Label the Classes

NOTE To enter the following label titles, an external keyboard may be used for convenience.

13. Press **LABEL CLASS** **MORE** **MORE** .

14. Change the label of the "TRL REFLECT" class to "TRLSHORT."

15. Change the label of the "TRL LINE OR MATCH" class to "TRLLINE."

16. Change the label of the "TRL THRU" class to "TRLTHRU."

17. Press **LABEL CLASS DONE** .

Label the Calibration Kit

18. Press **LABEL KIT** and create a label up to 8 characters long. For this example, enter "TRL KIT1" **DONE**.

19. To save the newly defined kit into nonvolatile memory, press:

KIT DONE (MODIFIED) **SAVE USER KIT**

NOTE Refer to ["Saving Modified Calibration Kits to a Disk" on page 7-65](#) for information about saving modified calibration kits, along with calibration data and instrument states, to a disk.

Perform the TRL Calibration

1. Press **Cal** **CAL KIT** **SELECT CAL KIT** **USER KIT** **RETURN** **RETURN** **CALIBRATE MENU** **TRL*/LRM* 2-PORT** .
2. To measure the "TRL THRU," connect the "zero length" transmission line between the two test ports.
3. To make the necessary four measurements, press **THRU THRU** .
4. To measure the "TRL SHORT," connect the short to PORT 1, and press:
S11 REFL: TRLSHORT .
5. Connect the short to PORT 2 and press **S22 REFL: TRLSHORT** .
6. To measure the "TRL LINE," disconnect the short and connect the TRL line from PORT 1 to PORT 2.
7. Press **LINE/MATCH** **DO BOTH FWD+REV** .
8. The line data is measured and the **LN/MATCH1 LINE** and **LN/MATCH2 LINE** softkey labels are underlined.
9. To measure the "ISOLATION" class, press **ISOLATION** .
 You could choose not to perform the isolation measurement by pressing **OMIT ISOLATION** **DONE TRL/LRM** .

NOTE You should perform the isolation measurement when the highest dynamic range is desired. To perform the best isolation measurements, you should reduce the system bandwidth or activate the averaging function.

A poorly measured isolation class can actually degrade the overall measurement performance. If you are in doubt of the isolation measurement quality, you should omit the isolation portion of this procedure.

NOTE If loads can be connected to both port 1 and port 2 simultaneously, then the following measurement can be performed using the **DO BOTH FWD+REV** softkey.

10. Connect a load to PORT 2, and press **REV ISOL'N ISOL'N STD** .
11. Connect the load to PORT 1, and press **FWD ISOL'N ISOL'N STD** **ISOLATION DONE** .
12. You may repeat any of the previous steps. There is no requirement to go in the order of steps. When the analyzer detects that you have made all the necessary measurements, the message line will show **PRESS 'DONE' IF FINISHED WITH CAL.** Press **DONE TRL/LRM** .

The message **COMPUTING CAL COEFFICIENTS** will appear, indicating that the analyzer is performing the numerical calculations of error coefficients.

NOTE You can save or store the measurement correction to use for later measurements. Refer to [Chapter 4 , "Printing, Plotting, and Saving Measurement Results"](#) for procedures.

13. Connect the device under test. The device S-parameters are now being measured.
-

LRM Error Correction

Create a User-Defined LRM Calibration Kit

In order to use the LRM technique, the calibration standards characteristics must be entered into the analyzer's user defined calibration kit.

The following steps show you how to define a calibration kit to utilize a set of LRM (LINE, REFLECT, MATCH) standards. This example LRM kit contains the following:

- zero length LINE
- "flush" short for the REFLECT standard (0 second offset)
- 50 ohm termination for the MATCH (infinite length line)

NOTE LRM with a zero length line is sometimes referred to as TRM (THRU, REFLECT, MATCH).

Modify the Standard Definitions

1. Press the following keys to start modifying the standard definitions:

Preset **Cal** **CAL KIT** **MODIFY** **DEFINE STANDARD**

2. To select a short, press **1** **x1**. (In this example, the REFLECT standard is a SHORT.)

3. Press the following keys:

SHORT **MODIFY STD DEFINITION** **SPECIFY OFFSET** **OFFSET DELAY** **0**
x1 **STD OFFSET DONE** **STD DONE (DEFINED)**

4. To define the THRU/LINE standard, press:

DEFINE STANDARD **4** **x1** **DELAY/THRU** **MODIFY STD DEFINITION**
SPECIFY OFFSET **OFFSET DELAY** **0** **x1** **STD OFFSET DONE**
STD DONE (DEFINED)

5. To define the LINE/MATCH standard, press:

DEFINE STANDARD **3** **x1** **LOAD**

6. For the purposes of this example, change the name of the standard by pressing

MODIFY STD DEFINITION **LABEL STD** **ERASE TITLE** , if a previous title exists, and then modify the name to "MATCH".

7. When the title area shows the new label, press:

DONE **STD DONE (DEFINED)**

Assign the Standards to the Various LRM Classes

8. To assign the calibration standards to the various TRL calibration classes, press:

Cal **CAL KIT** **MODIFY** **SPECIFY CLASS** **MORE** **MORE** **TRL REFLECT**

9. Since you previously designated standard #1 for the REFLECT standard, press:

1 **x1**

10. Since you previously designated standard #3 for the LINE/MATCH standard, press:

TRL LINE OR MATCH **3** **x1**

11. Since you previously designated standard #4 for the THRU/LINE standard, press:

TRL THRU **4** **x1**

12. To complete the specification of class assignments, press:

SPECIFY CLASS DONE

Label the Classes

NOTE To enter the following label titles, an external keyboard may be used for convenience.

13. Press **LABEL CLASS** **MORE** **MORE** .

14. Change the label of the "TRL REFLECT" class to "LRMSHORT."

15. Change the label of the "TRL LINE OR MATCH" class to "LRMLOAD."

16. Change the label of the "TRL THRU" class to "LRMTHRU."

17. Press **LABEL CLASS DONE** .

Label the Calibration Kit

18. Press **LABEL KIT** and create a label up to 8 characters long. For this example, enter "LRM KIT1" and press **DONE** .

19. To save the newly defined kit into nonvolatile memory, press:

KIT DONE (MODIFIED) **SAVE USER KIT**

NOTE Refer to ["Saving Modified Calibration Kits to a Disk" on page 7-65](#) for information about saving modified calibration kits, along with calibration data and instrument states, to a disk.

Perform the LRM Calibration

1. You must have a LRM calibration kit defined and saved in the USER KIT, as shown in ["Modifying Calibration Kits" on page 7-57](#).

NOTE This must be done before performing the following sequence.

2. Press **Cal** **CAL KIT** **SELECT CAL KIT** **USER KIT** **RETURN** **RETURN** **CALIBRATE MENU** **TRL*/LRM* 2-PORT**.
3. To measure the "LRM THRU," connect the "zero length" transmission line between the two test ports.
4. To make the necessary four measurements, press:
LRMTHRU
5. To measure the "LRM SHORT," connect the short to PORT 1, and press:
S11 REFL LRMSHORT
6. Connect the short to PORT 2, and press:
S22 REFL LRMSHORT

NOTE If loads can be connected to both port 1 and port 2 simultaneously, then the following LRM load measurement can be performed using the **DO BOTH FWD+REV** softkey.

7. To measure the "LRM LOAD," disconnect the short and connect the LRM load to PORT1.
8. Press **LINE/MATCH** **LN/MATCH1 LOAD** to access the No Loads menu. When the displayed trace settles, press the softkey corresponding to the load used. If a sliding load is used, press **SLIDING** to access the Sliding Load menu. Position the slide and press **SLIDE IS SET**.
9. When all the appropriate load measurements are complete, the load data is measured and the **LN/MATCH1 LOAD** softkey label is underlined.
10. Connect the load to PORT 2 and press **LN/MATCH2 LOAD**.
11. Repeat the previous LRM load measurement steps for PORT 2.
12. After the measurement is complete, press:
DONE LINE/MATCH
13. To measure the "ISOLATION" class, press:
ISOLATION
 You could choose not to perform the isolation measurement by pressing **OMIT ISOLATION** **DONE TRL/LRM**.

NOTE You should perform the isolation measurement when the highest dynamic range is desired.

To perform the best isolation measurements, you should reduce the system bandwidth or activate the averaging function.

Calibrating for Increased Measurement Accuracy

LRM Error Correction

A poorly measured isolation class can actually degrade the overall measurement performance. If you are in doubt of the isolation measurement quality, you should omit the isolation portion of this procedure.

14. You may repeat any of the previous steps. There is no requirement to go in the order of steps. When the analyzer detects that you have made all the necessary measurements, the message line will show PRESS 'DONE' IF FINISHED WITH CAL. Press **DONE TRL/LRM** .

The message COMPUTING CAL COEFFICIENTS will appear, indicating that the analyzer is performing the numerical calculations of error coefficients.

NOTE You can save or store the measurement correction to use for later measurements. Refer to [Chapter 4 , "Printing, Plotting, and Saving Measurement Results"](#) for procedures.

15. Connect the device under test. The device S-parameters are now being measured.
-

NOTE When making measurements using the same port with uncoupled channels, the power level for each channel must fall within the same power range setting of that single port. An error message will be displayed if you enter two power levels that do not fall within the same power range.

Calibrating Using Electronic Calibration (ECal)

This section describes Electronic Calibration (ECal).

Use the following steps to perform the calibration.

1. Set up the measurement for which you are calibrating. Refer to "Set Up the Measurement."
2. Connect the ECal equipment. Refer to "Connect the ECal Equipment" on page 6-58.
3. Select the ECal options. Refer to "Select the ECal Options" on page 6-59.
4. Perform the calibration. Refer to "Perform the Calibration" on page 6-61.
5. Perform the confidence check. Refer to "Perform the Confidence Check" on page 6-64.

Set Up the Measurement

1. Press **Preset**.
2. Select the type of measurement you want to make.
 - If you want to make a reflection measurement on PORT 1 (in the forward direction, S_{11}), leave the instrument default setting or press:
Meas Refl: FWD S11 (A/R) or on ET models: **REFLECTION**
 - If you want to make a transmission measurement in the forward direction (S_{21}), press:
Meas Trans: FWD S21 (B/R) or on ET models: **TRANSMISSN**
 - For ES analyzers, if you want to make a transmission measurement in the reverse direction (S_{12}), press:
Meas Trans: REV S12 (A/R)
 - For ES analyzers, if you want to make a reflection measurement on PORT 2 (in the reverse direction, S_{22}), press:
Meas Refl: REV S22 (B/R)
3. Set any other measurement parameters that you want for the device measurement: frequency, span, power, sweep type, number of points, or IF bandwidth.

Connect the ECal Equipment

1. Connect the power supply to the PC interface unit. Refer to [Figure 6-21](#).

Figure 6-21 ECal Setup

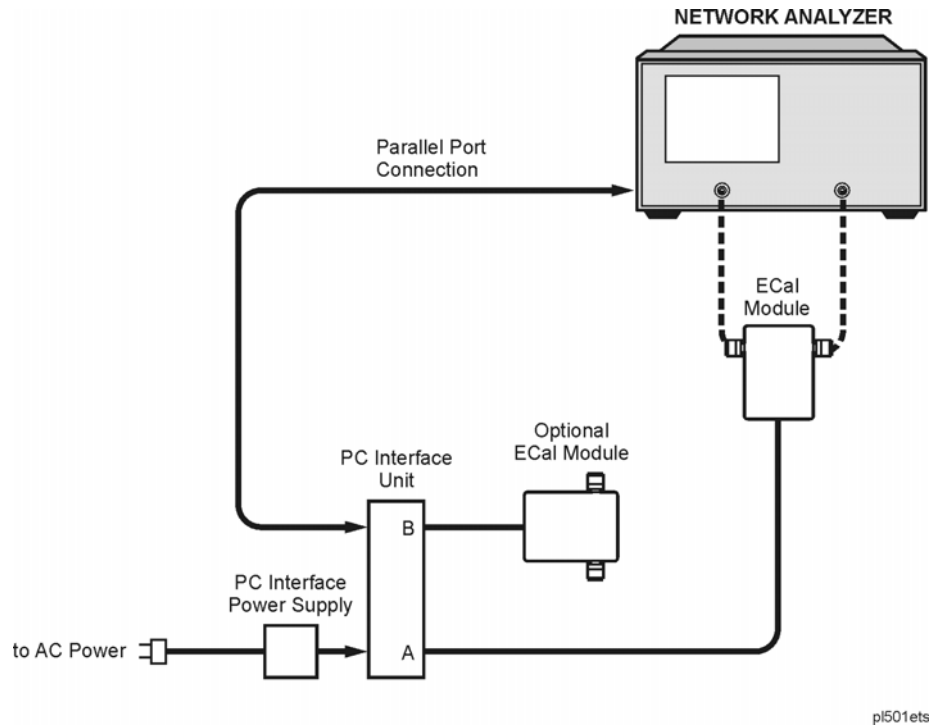

2. Connect the power supply to the ac source.
3. Connect one end of a DB25 cable to the Parallel Port connector on the rear of the network analyzer. Connect the other end of the DB25 cable to the connector on the PC interface unit labeled "DB25 Interface to Parallel Interface on Personal Computer."

CAUTION Only connect the DB25 cable to the **Parallel Port** connector of the network analyzer. If the cable is connected to the Test Set - I/O Interconnect connector, damage to the PC interface unit could occur.

NOTE For steps 3 through 5, use the three DB25 cables (part number 8120-8710) shipped with the 85097A Electronic Calibration System. Other cables may not give reliable results.

4. Connect one end of a DB25 cable to the connector on the PC interface unit labeled "DB25 Interface to ECal Module A." Connect the other end of the DB25 cable to the parallel cable connector on the ECal module.

5. If you need to calibrate with a second ECal module, connect one end of another DB25 cable to the connector on the PC interface unit labeled "DB25 Interface to ECal Module B". Connect the other end of the DB25 cable to the parallel cable connector on the ECal module.

NOTE Why Use a Second ECal Module?

If the frequency span of the measurement that you set up earlier exceeds the span of a single ECal module, you need to use another ECal module whose frequency range allows the rest of the measurement span to be calibrated. The frequency range of the ECal modules is listed in the "General Information" chapter of the 85097A Electronic Calibration System User's Guide.

6. Using an RF cable (or a microwave cable, as appropriate), connect one port of the ECal module to test port 1 of the analyzer. Refer to [Figure 6-21](#).

CAUTION RF ECal modules can be damaged if you apply excessive torque to the connectors. Do not exceed the recommended torque indicated in the Electronic Calibration Module Reference Guide (part number 85091-90009).

NOTE It is not critical which ECal module port (Port A or Port B) is connected to the network analyzer test ports. The network analyzer detects where each ECal module port is connected and uses the appropriate module data. If Port A is connected to Port 1 of the analyzer, the calibration will be performed slightly faster.

7. Using an RF cable (or a microwave cable, as appropriate), connect the other port of the ECal module to test port 2 of the analyzer.

Select the ECal Options

In addition to the standard ECal method, there are two options that you may want to use when performing the electronic calibration. They are:

- ECal using a manual thru

Calibration using a **manual thru** is more accurate than calibrating using the thru internal to the ECal module. (A zero-length thru is created by connecting the two test port cables together.) The improved loss of the manual thru compared to the ECal module's thru, increases the accuracy of other error terms in the correction. The accuracy of the overall calibration is improved. Manual thrus can only be used with ECal modules having connectors of the opposite sex.

- ECal using isolation averaging

During the isolation measurement portion of ECal, you are actually measuring instrument crosstalk. Typically, the data during this measurement is near the noise floor. (See also "[Omitting Isolation Calibration](#)" on page 6-4.)

When the crosstalk is near (or in) the noise floor, one way to reduce the noise is to turn on the isolation averaging. When the random noise of the instrument is averaged, its magnitude declines. As the energy of the trace is averaged, the displayed data becomes smoother. When the random noise is reduced, the network analyzer display shows the non-random crosstalk data.

NOTE If you are performing an ECal using two modules, selecting either option sets up the option to be performed with both modules.

To Select the Manual Thru Calibration Option

1. To select the manual thru calibration option, press **Cal** **ECal MENU** **CONFIGURE []**.
2. Press **MAN'L THRU on OFF** until **ON** is selected.
3. Press **RETURN**.
4. Continue with step 2 of "[Perform the Calibration](#)" on page 6-61.

To Select the Isolation Calibration Option

1. To select the isolation calibration option, press **Cal** **ECal MENU** **CONFIGURE []**.
2. Press **OMIT ISOLATION ON off** until **OFF** is selected.
The isolation measurement is normally off. Therefore, the default setting for the **OMIT ISOLATION ON off** softkey is **ON**. When isolation is *not* omitted (**OMIT ISOLATION on OFF**), isolation standards are measured.
3. Press **ISOLATION AVERAGES**, enter the isolation averages numeric value on the front panel keypad, and then press **x1**.

NOTE The isolation averaging default is set to take 10 sweeps. This isolation averaging value is less than the network analyzer default sweep averaging value of 16.

4. Press **RETURN**.
5. Continue with step 2 of "[Perform the Calibration.](#)"

Perform the Calibration

1. Press **Cal** **ECal MENU** .

When ECal is first selected (or when you select module A or module B), there is a small initial delay so that the network analyzer can detect and download the calibration information from the internal memory of the ECal module.

2. Press **MODULE A b** so that A is selected.

NOTE If you are calibrating with two modules, the overlapping frequency span will be determined by the second module. Therefore, if you want to use the calibration data of Module A in the overlapping frequency span, calibrate using Module B first, and then calibrate using Module A.

3. Press the ECal calibration selection.

- The calibration choices for ES models are:
 - **S11 1-PORT** performs a measurement calibration for reflection-only. Measures of one-port devices or properly terminated two-port devices, at port 1 of an S-parameter test set.
 - **S22 1-PORT** performs a measurement calibration for reflection-only. Measures of one-port devices or properly terminated two-port devices, at port 2 of an S-parameter test set.
 - **FULL 2-PORT** performs a complete calibration for measurement of all four S-parameters of a two-port device. This is the most accurate calibration for measurements of two-port devices.
 - **S11/S21 ENH. RESP.** performs an S11 and S21 enhanced response calibration (forward direction). Enhanced response generates a 1-port cal for S11 and an improved calibration over the response cal for S21.
 - **S22/S12 ENH. RESP.** performs an S22 and S12 enhanced response calibration (reverse direction). Enhanced response generates a 1-port cal for S22 and an improved calibration over the response cal for S12.
- The calibration choices for ET models are:
 - **REFLECTION 1-PORT** performs a reflection 1-port calibration.
 - **TRANS/REFL ENH. RESP.** performs a transmission (same as S21) and reflection (same as S11) enhanced response calibration (forward direction). Enhanced response generates a 1-port cal for reflection and an improved calibration over the response cal for transmission.

Once the ECal calibration selection is made, the network analyzer performs the calibration.

4. If you selected the manual thru calibration option, when the prompt is displayed, remove the ECal module from the setup and connect the manual thru (the two test ports connected together) as shown in [Figure 6-22](#).

Figure 6-22 Manual Thru Setup

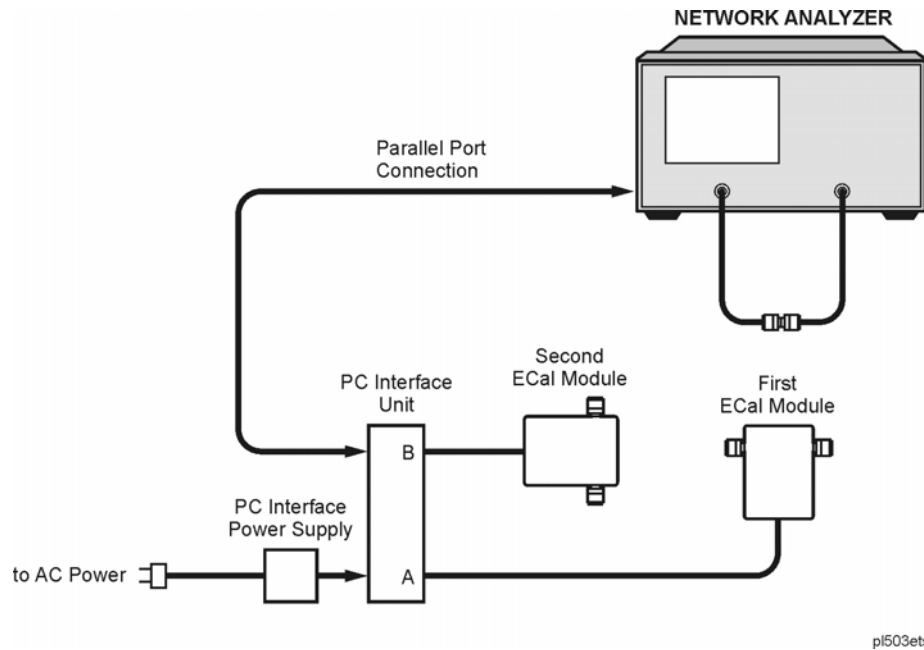

5. After you connect the manual thru, press **CONTINUE ECal** to complete the manual thru portion of the ECal.
6. If you are calibrating using two ECal modules, a prompt is displayed directing you to remove the first module and connect the second module. Follow this prompt as shown in [Figure 6-23](#).

Figure 6-23 Connect the Second ECal Module

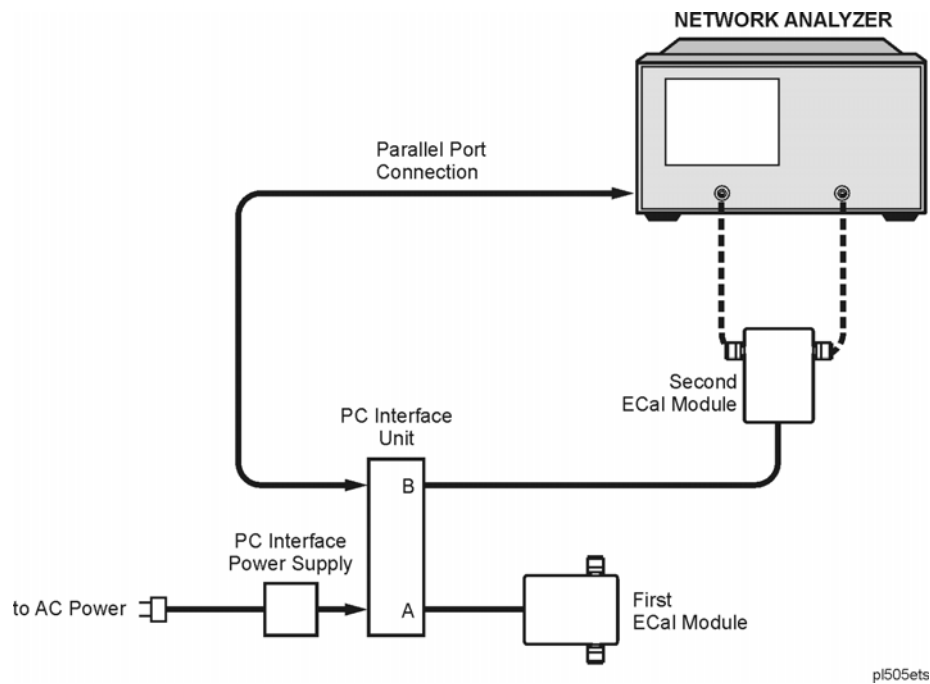

7. After you connect the second ECal module, press **CONTINUE ECal** to continue the ECal.
8. Repeat steps 4 and 5 if you selected to calibrate using the manual thru option.
9. Review the displayed calibration results. Refer to "[Perform the Confidence Check](#)" on page 6-64.
10. Save the calibration results by pressing **Save/Recall**.

Display the Module Information

Display information about the module by pressing **Cal** **ECal MENU** **CONFIGURE []** **MODULE INFO**.

A text window is displayed that contains the following information about the selected module.

1	PC interface unit port to which it is connected	6	Number of measurement points
2	Model number	7	Start (minimum) frequency
3	Serial number	8	Stop (maximum) frequency
4	Connector type	9	Suggested warmup time
5	Date of last certification	10	Warmup status (This is the remaining time on an internal analyzer timer. The timer simply counts down the recommended ECal module warm-up time. When the timer reaches zero, a message is displayed indicating that the ECal module is ready. The ECal module temperature or status is <i>not</i> read. The timer is reset when the analyzer is powered up or preset or when a new module is attached.)

Perform the Confidence Check

The confidence check is a means of visually checking the quality of the calibration. The confidence check displays the currently measured data (DATA trace) and the factory-premeasured data (MEM trace) for the module's confidence state. The confidence state, an independent reference standard, was not used for the calibration. For a good calibration measurement, there should be no significant difference between the traces (see [Figure 6-24](#)).

To Perform the Confidence Check

NOTE A confidence check is only valid after an ECal has been performed.

1. Press **Cal** **ECal MENU** **CONFIGURE []**.
2. Press **MODULE A b** until the correct module (A or B) is selected.
3. Select **CONFIDENCE CHECK** to display the confidence check and the ECal Confidence Menu.
4. Press **PARAMETER []** until the S-parameter that you want to view is displayed.

Pressing the **PARAMETER []** softkey toggles between the **S11**, **S21**, **S12**, and **S22** (or for the ET models, **TRANS** (transmission) and **REFL** (reflection)) calibration traces. The confidence check will only display the S-parameter calibration data for which you calibrated. Uncalibrated S-parameter data traces are invalid. The memory trace still displays the module's factory-premeasured trace.

For example,

If you performed:	You can view:
A 1-port calibration <ul style="list-style-type: none"> • S11 1-PORT (ES models) • S22 1-PORT (ES models) • REFLECTION 1-PORT (ET models) 	Only one calibrated S-parameter
An enhanced response calibration <ul style="list-style-type: none"> • S11/S21 ENH. RESP. (ES models) • S22/S12 ENH. RESP. (ES models) • TRANS/REFL ENH. RESP. (ET models) 	Only two calibrated S-parameters, one at a time
A full 2-port calibration <ul style="list-style-type: none"> • FULL 2-PORT (ES models) 	All four calibrated S-parameters, one at a time

- Press **TRACE TYPE []** until the calibration confidence check trace that you want to view is displayed.

Pressing the **TRACE TYPE []** softkey toggles between the five trace-type display options. The confidence check can display the measured ECal results (DATA) and the premeasured calibration data (MEM) in following five ways.

- **DATA&MEM** displays two traces representing the measured ECal results and module's premeasured calibration data trace.
 - **DATA/MEM** displays a single trace representing the ratio of the measured ECal results to the module's premeasured calibration data.
 - **DATA-MEM** displays a single trace representing the difference between the measured ECal results and the module's premeasured calibration data.
 - **DATA** displays a single trace representing only the measured ECal results.
 - **MEM** displays a single trace representing only the module's premeasured calibration data.
- If you want to change the scale of the display, press **AUTO SCALE**.

The **AUTO SCALE** softkey is located in this menu for convenience in viewing the confidence check data. It acts the same as **AUTO SCALE** under the **Scale Ref** key.

- Review the confidence check display.

Figure 6-24 Confidence Check Display showing DATA&MEM Trace Type

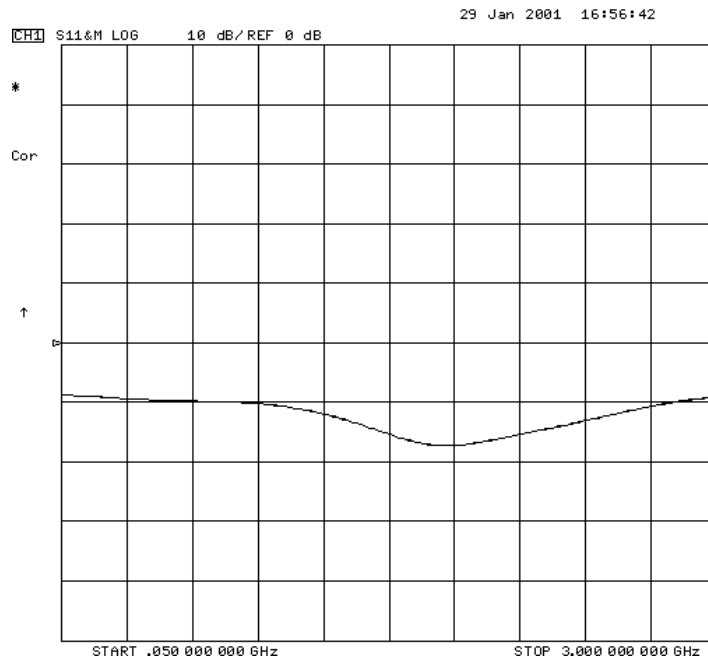

- If you want to check other calibration S-parameters or trace types, repeat steps 4 through 7.
- When finished, select **RETURN** to complete the confidence check.

Investigating the Calibration Results Using the ECal Service Menu

CAUTION The confidence check described in the previous section displays the ECal data of a single state. This confidence state is a calibrated standard *not* used during ECal. It is provided to give an independent assessment of the quality of a calibration. In the ECal Service menu, you may also display each of the calibration standards which are used during an ECal calibration, along with the analyzer's measurement of those standards.

You may notice a difference in measurement results when comparing ECal confidence state data and ECal standard state data. This result may be related to certain measurement errors with the network analyzer system, which add uncertainty to measurement results. More detailed information regarding measurement uncertainty is documented in the "Determining System Measurement Uncertainties" chapter of the network analyzer's reference guide. Additional information on improving your measurements can be found in [Chapter 5](#), "Optimizing Measurement Results."

Using the ECal Service menu is not a standard part of the ECal procedure. It is a tool to allow you to identify problems in the calibration equipment, cables, connectors, or procedures.

The Confidence Check menu supports the comparison of the measured data versus the module's premeasured calibration data for the confidence state. The ECal Service menu supports the comparison of the measured data versus the module's premeasured calibration data for the remainder of the module states, in addition to the confidence state.

Access the ECal Service menu by pressing **ECal SERVICE** from the Confidence Check menu.

The ECal Service menu softkeys are:

ECal STD [] Toggles the analyzer to show the data for the following calibration states:

- **CONF** (Confidence)
- **THRU**
- **ISOL** (Isolation)
- **S11 REFL** (S11 Reflection)
- **S22 REFL** (S22 Reflection)

REFL STD [] Toggles between the available S11 and S22 reflection states listed in the **ECal STD []** softkey described above.

- **S11 REFL** allows up to 13 reflection states.
- **S22 REFL** allows up to 13 reflection states.

NOTE When there is no premeasured calibration data for a given state and measurement parameter, a warning is displayed indicating that no module data is available.

PARAMETER []

Toggles the analyzer to show the data for the following S-parameters:

- **S11** (ES models)
- **S21** (ES models)
- **S12** (ES models)
- **S22** (ES models)
- **RFL** (ET models) - Reflection
- **TRN** (ET models) - Transmission

TRACE TYPE []

Toggles through the following trace types:

- **DATA&MEM** displays two traces representing the measured ECal results and the module's premeasured calibration data trace.
- **DATA/MEM** displays a single trace representing a ratio of the measured ECal results to the module's premeasured calibration data.
- **DATA-MEM** displays a single trace representing the difference between the measured ECal results and the module's premeasured calibration data.
- **DATA** displays a single trace representing only the measured ECal results.
- **MEM** displays a single trace representing only the module's premeasured calibration data.

AUTO SCALE

Changes scale and reference values to bring the trace data in view on the display. The analyzer determines the smallest possible scale factor that will put all displayed data onto 80% of the vertical graticule. The reference value is chosen to put the trace in center screen.

RETURN

Returns to the ECal Confidence Check menu.

NOTE

When returning to the Confidence Check menu from the ECal Service menu, press the **SET CONF STANDARD** softkey on the ECal Confidence Check menu. If this softkey is not pressed, the confidence check information displayed may not be accurate.

Adapter Removal Using ECal (ES Analyzers Only)

A device under test (DUT) whose connectors cannot be connected directly to a test configuration is considered to be a *noninsertable device*. See [Figure 6-25](#) Noninsertable devices can be caused because the DUT has:

- Input or output connectors with the same sex connector as the test configuration.
- Input or output connectors of a different connector type than the test configuration.

Figure 6-25 Noninsertable Device

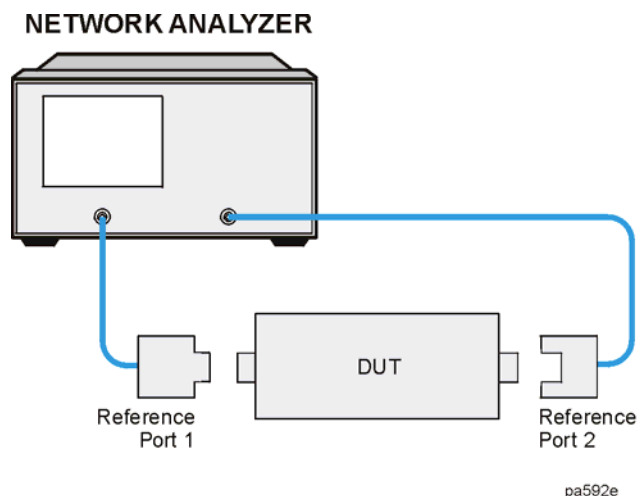

The adapter removal calibration technique may be used with the ECal calibration to accurately measure noninsertable devices. The following adapters (shown in [Figure 6-26](#)) are needed.

- Adapter A1, which mates with port 1 of the DUT, must be installed on Port 1 of the analyzer.
- Adapter A2, which mates with port 2 of the DUT, must be installed on Port 2 of the analyzer.
- Adapter A3 must match the connectors on the DUT. The effects of this adapter will be completely removed with this calibration technique.

NOTE Adapters A1 and A2 become part of the test setup to allow connection to the DUT. Adapter A3 is used during the calibration only. Its effects will be removed.

Figure 6-26 Adapters Needed

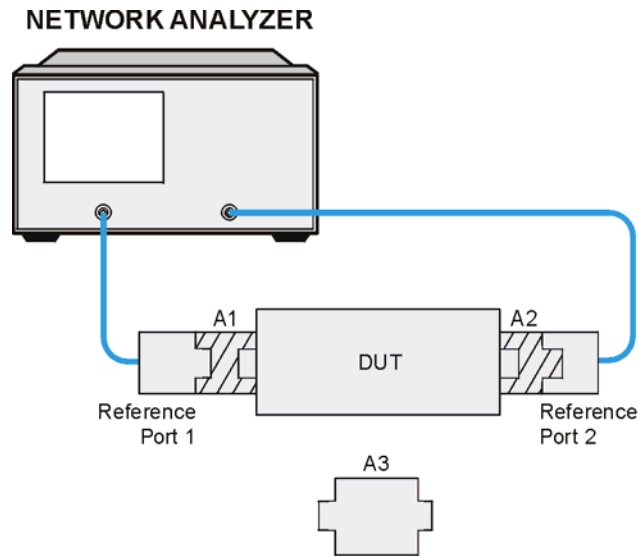

The following requirements must also be met:

- An ECal module for performing a 2-port error correction for each connector type must be available.
- Specified electrical length of adapter A3 within $\pm 1/4$ wavelength for the measurement frequency range.

For each port, a separate 2-port error correction needs to be performed to create two calibration sets. The adapter removal algorithm uses the resultant data from the two calibration sets and the nominal electrical length of the adapter to compute the adapter's actual S-parameters. This data is then used to generate a separate third calibration set in which the forward and reverse match and tracking terms are as if port 1 and port 2 could be connected. This is possible because the actual S-parameters of the adapter are measured with great accuracy, thus allowing the effects of the adapter to be completely removed when the third calibration set is generated.

Perform the 2-Port Error Corrections

1. Connect adapter A3 to adapter A2 on port 2 as shown in [Figure 6-27](#).

Figure 6-27 Two-Port Cal Set 1

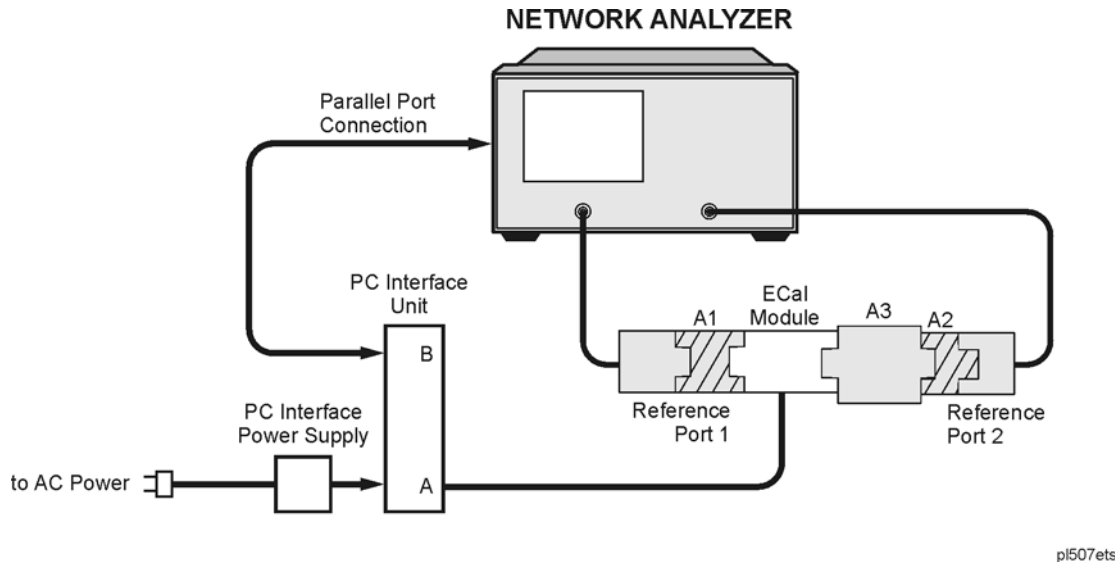

2. Connect the ECal module between adapter A1 and adapter A3.
3. Press **Cal** **ECal MENU** **MODULE A b**.
4. Press **FULL 2-PORT** to perform the first 2-port error correction using the ECal module.

NOTE When using adapter removal calibration, you must save calibration sets to the internal disk, not to internal memory.

5. Save the results to disk. Name the file "PORT1."
6. Remove the ECal module and adapter A3 from the setup. Connect adapter A3 to adapter A1 on port 1 as shown in [Figure 6-28](#).

Figure 6-28 Two-Port Cal Set 2

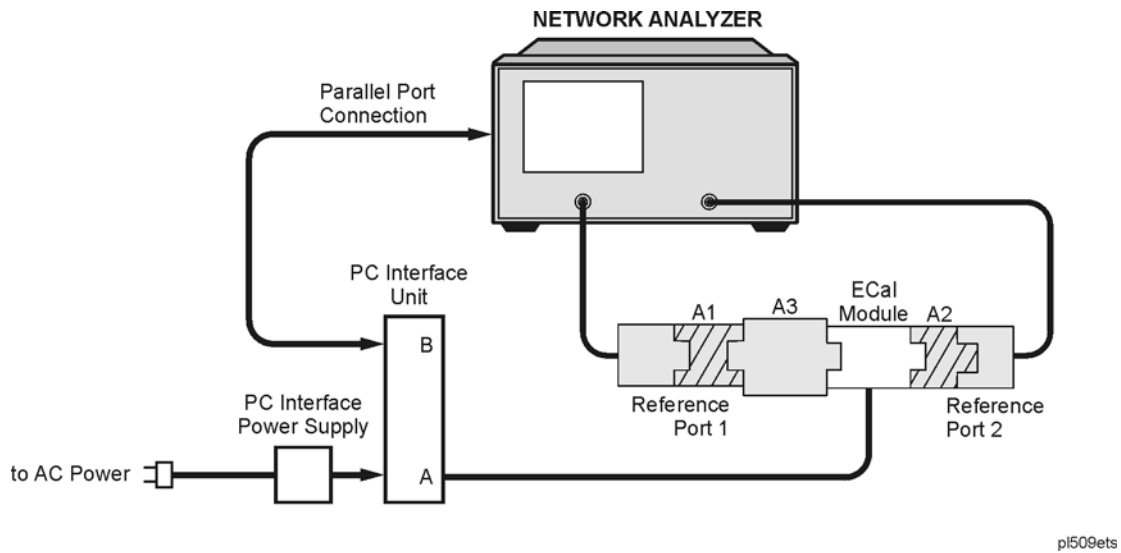

7. Connect the ECal module between adapter A3 and adapter A2.
8. Press **Cal** **Ecal MENU** .
9. Press **FULL 2-PORT** to perform the second 2-port error correction using the ECal module.
10. Save the results to disk. Name the file "PORT2."
11. Determine the electrical delay of adapter A3. If you have adapter specifications that identify the electrical delay, you may use that information and continue with ["Remove the Adapter" on page 6-73](#). If you do not know the delay of adapter A3, perform the "Determine the Electrical Delay" procedure on [page 6-72](#).

Determine the Electrical Delay

This procedure determines the electrical delay of adapter A3 using a short.

1. Refer to [Figure 6-29](#) while performing the steps in this procedure.
2. Perform a 1-port calibration at "Reference Port 1". Refer to Step A of [Figure 6-29](#).

This 1-port calibration can either be a manual calibration or an ECal.

Figure 6-29 Determining the Electrical Delay Setup

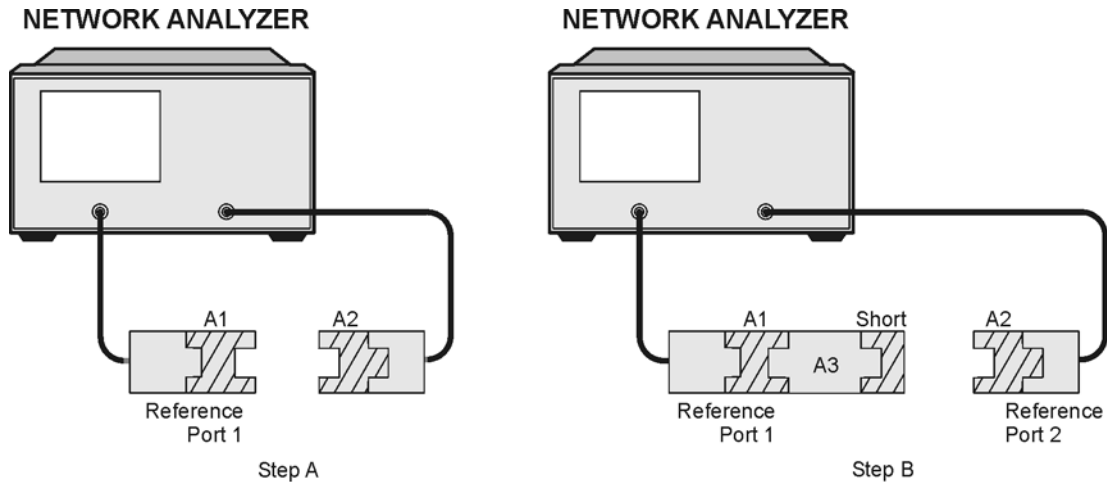

pl511ets

3. Connect the A3 adapter to "Reference Port 1" as shown in Step B of [Figure 6-29](#). Connect a short to the open end of the A3 adapter.
4. Measure the delay of the adapter by pressing **Format** **DELAY**.
5. Divide the resulting delay measurement by 2 to determine the delay of the thru and the short in one direction.
6. Determine the offset delay of the calibration short by examining the define standard menu (see ["Define Standard Menus" on page 7-59](#)).
7. Subtract the offset delay of the short (determined in step 6) from the delay of the thru and the short in one direction (determined in step 5). The result is electrical delay of the thru. This value is used in the next procedure.

Remove the Adapter

When the two sets of error correction files have been created (now referred to as "calibration sets"), the A3 adapter may be removed.

1. Press **Cal** **MORE** **ADAPTER REMOVAL** to display the following menu:

HELP ADAPT REMOVAL (This Help softkey provides a quick reference guide to using the adapter removal technique.)

RECALL CAL SETS

ADAPTER DELAY

ADAPTER COAX

ADAPTER WAVEGUIDE

REMOVE ADAPTER

2. Press **RECALL CAL SETS** to display **RECALL CAL PORT 1** and **RECALL CAL PORT 2**.

RECALL CAL SETS also displays the internal (or external if internal not used) disk file directory.

NOTE In the following two steps, calibration data is recalled, not instrument states.

3. From the disk directory, choose the file associated with the port 1 error correction, then press **RECALL CAL PORT 1**.
4. When this is complete, choose the file for the port 2 error correction and press **RECALL CAL PORT 2**.
5. When complete, press **RETURN**.
6. Enter the value of adapter A3 electrical delay by pressing **ADAPTER DELAY** and entering the value.
7. Select the appropriate key: **ADAPTER COAX** or **ADAPTER WAVEGUIDE**.
8. Press **REMOVE ADAPTER** to complete the technique for calculating the new error coefficients and overwrite the current active calibration set in use.

This process uses up an internal memory register. The calibration in this register is *not* the calibration created by adapter removal, rather it is a "scratch" calibration. You may wish to delete the register, or re-save the new calibration in this register as shown in the following step.

9. To save the results of the new calibration set, press **Save/Recall** **SELECT DISK** **INTERNAL MEMORY** **RETURN** **SAVE STATE**.

NOTE Adapter removal can leave a residual state in internal memory. This is not a valid instrument state and should be deleted.

10. Connect the DUT to the network analyzer as shown in [Figure 6-30](#) to perform calibrated measurements.

Figure 6-30 Calibrated Measurement

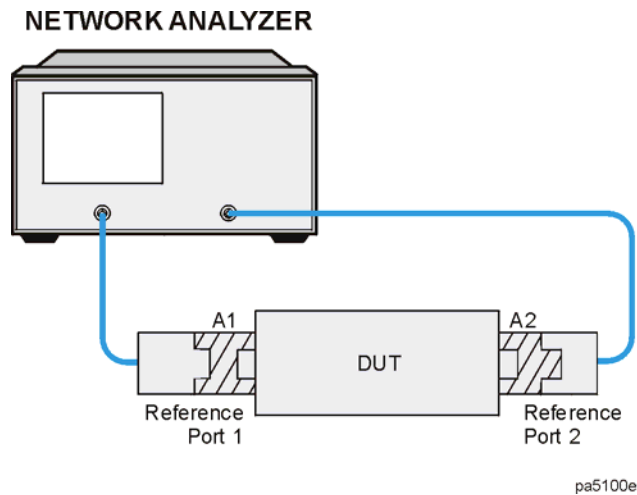

Verify the Results

Since the effect of the adapter has been removed, it is easy to verify the accuracy of the technique by simply measuring the adapter itself. Because the adapter was used during the creation of the two calibration sets, and the technique removes its effects, measurement of the adapter itself should show the S-parameters.

If unexpected phase variations are observed, this indicates that the electrical delay of the adapter was not specified within a quarter wavelength over the frequency range of interest. To correct this, recall both cal sets, since the data was previously stored to disk, change the adapter delay, and press

REMOVE ADAPTER

7 Operating Concepts

Using This Chapter

This chapter provides conceptual information on how specific functions of the network analyzer operate. The following topics are discussed:

- “System Operation” on page 7-3
- “Processing” on page 7-5
- “Output Power” on page 7-9
- “Sweep Time” on page 7-11
- “Source Attenuator Switch Protection” on page 7-13
- “Channel Stimulus Coupling” on page 7-14
- “Sweep Types” on page 7-15
- “S-Parameters” on page 7-20
- “Analyzer Display Formats” on page 7-24
- “Electrical Delay” on page 7-33
- “Noise Reduction Techniques” on page 7-34
- “Measurement Calibration” on page 7-37
- “Calibration Routines” on page 7-54
- “Modifying Calibration Kits” on page 7-57
- TRL/LRM Calibration
- “GPIB Operation” on page 7-76
- “Limit Line Operation” on page 7-80
- “Knowing the Instrument Modes” on page 7-82

Where to Find More Information

- Operation concepts relating to mixer measurements and time domain measurements can be found in [Chapter 2](#), “Making Mixer Measurements (Option 089 Only)” and [Chapter 3](#), “Making Time Domain Measurements.”
- Descriptions of all instrument functions are located in the “Hardkey/Softkey Reference” chapter of the reference guide.
- Procedures for using instrument functions, making measurements, recording measurement results, and performing calibrations are located in [Chapter 1](#), “Making Measurements” and [Chapter 6](#), “Calibrating for Increased Measurement Accuracy.”

System Operation

Network analyzers measure the reflection and transmission characteristics of devices and networks. A network analyzer test system consists of the following:

- source
- signal-separation devices
- receiver
- display

The analyzer applies a signal that is transmitted through the test device, or reflected from its input, and then compares it with the incident signal generated by the swept RF source. The signals are then applied to a receiver for measurement, signal processing, and display.

The vector network analyzer integrates a high resolution synthesized RF source, test set, and a dual channel three-input receiver to measure and display magnitude, phase, and group delay of transmitted and reflected power. With Option 010, the analyzer has the additional capability of transforming measured data from the frequency domain to the time domain. Other options are explained in “Options and Accessories” chapter of the reference guide. A simplified block diagram of the network analyzer system is shown in [Figure 7-1](#). A detailed block diagram of the analyzer is provided in the service guide together with a theory of system operation.

Figure 7-1 Simplified Block Diagram of the Network Analyzer System

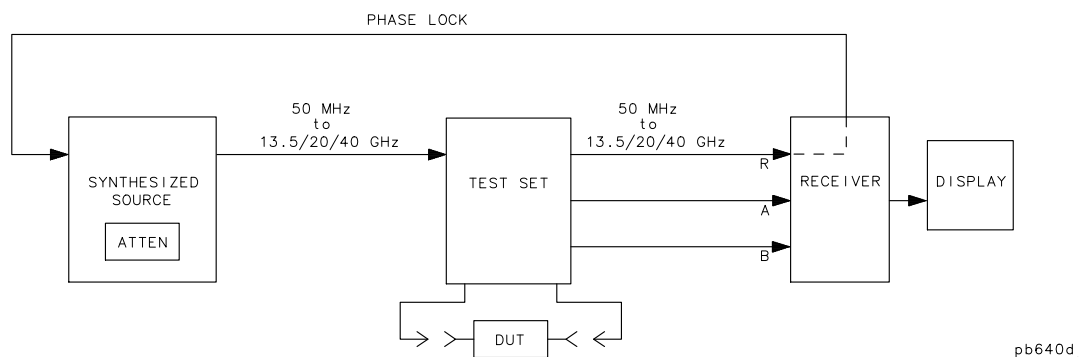

The Built-In Synthesized Source

The analyzer's built-in synthesized source produces a swept RF signal or CW (continuous wave) signal in the following ranges:

- 8719ET/ES: 50 MHz to 13.5 GHz
- 8720ET/ES: 50 MHz to 20.0 GHz
- 8722ET/ES: 50 MHz to 40.0 GHz

The RF output power is leveled by an internal ALC (automatic leveling control) circuit. To achieve frequency accuracy and phase measuring capability, the analyzer is phase locked to a highly stable crystal oscillator. For this purpose, a portion of the transmitted signal is routed to the R channel input of the receiver, where it is sampled by the phase detection loop and fed back to the source.

The Source Step Attenuator

The step attenuator contained in the source is used to adjust the power level to the test device without changing the level of the incident power in the reference path.

The Built-In Test Set

The ES model features a built-in test set that provides signal-separation devices and connections to the device under test. The signal separation devices are needed to separate the incident signal from the transmitted and reflected signals. The incident signal is applied to the R channel input through a jumper cable on the front panel. Meanwhile, the transmitted and reflected signals are internally routed from the test port couplers to the inputs of the A and B sampler/mixers in the receiver. Port 1 is connected to the A input and port 2 is connected to the B input. A transfer switch routes the source output power to either port 1 or 2, allowing measurements to be made in both the forward and reverse directions.

The ET model features a built-in test set that provides signal-separation and connections to the device under test. Part of the source output is coupled off and applied to the R input as the incident signal. The reflected signal is routed from the port 1 coupler to the input of the A sampler. The transmitted signal is routed from port 2 to the B sampler input.

The Receiver Block

The receiver block contains three sampler/mixers for the R, A, and B inputs. Instruments equipped with Option 400 contain an additional R sampler/mixer. The signals are sampled, and mixed to produce a 4 kHz IF (intermediate frequency). A multiplexer sequentially directs each of the three IF signals (four IF signals in Option 400) to the ADC (analog to digital converter) where it is converted from an analog to a digital signal. The signals are then measured and processed for viewing on the display. Both amplitude and phase information are measured simultaneously, regardless of what is displayed on the analyzer.

The Microprocessor

A microprocessor takes the raw data and performs all the required error correction, trace math, formatting, scaling, averaging, and marker operations, according to the instructions from the front panel or over GPIB. The formatted data is then displayed. The data processing sequence is described in [“Processing” on page 7-5](#).

Required Peripheral Equipment

Measurements require calibration standards for vector accuracy enhancement (error-correction), and cables for interconnections. Model numbers and details of compatible power splitters, calibration kits, and cables are provided in “Options and Accessories” chapter of the reference guide.

Processing

The analyzer's receiver converts the R, A, and B input signals into useful measurement information. This conversion occurs in two main steps:

- The swept high frequency input signals are translated to fixed low frequency IF signals, using analog sampling or mixing techniques. (Refer to the service guide for more details on the theory of operation.)
- The IF signals are converted into digital data by an analog to digital converter (ADC). From this point on, all further signal processing is performed mathematically by the analyzer microprocessors.

The following paragraphs describe the sequence of math operations and the resulting data arrays as the information flows from the ADC to the display. They provide a good foundation for understanding most of the response functions, and the order in which they are performed.

Figure 7-2 is a data processing flow diagram that represents the flow of numerical data from IF detection to display. The data passes through several math operations, denoted in the figure by single line boxes. Most of these operations can be selected and controlled with the front panel response block menus. The data, stored in arrays along the way and denoted by double line boxes, are places in the flow path where data is accessible via GPIB.

Figure 7-2 Data Processing Flow Diagram

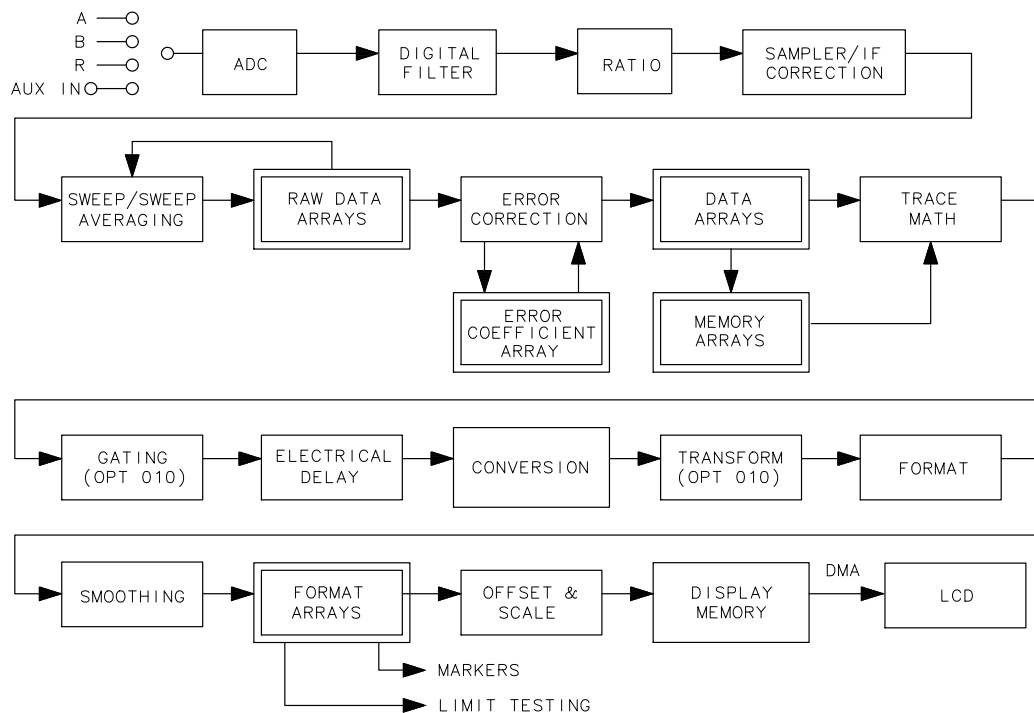

pb6116d

While only a single flow path is shown, two identical paths are available, corresponding to channel 1 and channel 2. Each channel also has an auxiliary channel for which the data is processed along with the primary channel's data. Channel 3 is the auxiliary channel for channel 1, while channel 4 is the auxiliary channel for channel 2. When the channels are uncoupled, each channel is processed and controlled independently.

Data point definition: A "data point" or "point" is a single piece of data representing a measurement at a single stimulus value. Most data processing operations are performed point-by-point; some involve more than one point.

Sweep definition: A "sweep" is a series of consecutive data point measurements, taken over a sequence of stimulus values. A few data processing operations require that a full sweep of data is available. The number of points per sweep can be defined by the user. The units of the stimulus values (such as power, frequency, and time) can change, depending on the sweep mode, although this does not generally affect the data processing path.

Processing Details

The ADC

The ADC (analog-to-digital converter) converts the R, A, and B inputs (already down-converted to a fixed low frequency IF) into digital words. (The AUX INPUT connector on the rear panel is a fourth input.) The ADC switches rapidly between these inputs, so they are converted nearly simultaneously.

IF Detection

This detection occurs in the digital filter, which performs the discrete Fourier transform (DFT) on the digital words. The samples are converted into complex number pairs (real plus imaginary, $R+jX$). The complex numbers represent both the magnitude and phase of the IF signal. If the AUX INPUT is selected, the imaginary part of the pair is set to zero. The DFT filter shape can be altered by changing the IF bandwidth, which is a highly effective technique for noise reduction.

Ratio Calculations

These calculations are performed if the selected measurement is a ratio of two inputs (for example, A/R or B/R). This is a complex divide operation. If the selected measurement is absolute (such as A or B), no calculations are performed. The R, A, and B values are also split into channel data at this point.

Sampler/IF Correction

The next digital processing technique used is sampler/IF correction. This process digitally corrects for frequency response errors (both magnitude and phase, primarily sampler rolloff) in the analog down-conversion path.

Sweep-To-Sweep Averaging

Averaging is another noise reduction technique. This calculation involves taking the complex exponential average of several consecutive sweeps. This technique cannot be used with single-input measurements.

Pre-Raw Data Arrays

These data arrays store the results of all the preceding data processing operations. (Up to this point, all processing is performed real-time with the sweep by the IF processor. The remaining operations are not necessarily synchronized with the sweep, and are performed by the main processor.) When full 2-port error

correction is on, the raw arrays contain all four S-parameter measurements required for accuracy enhancement. When the channels are uncoupled (**COUPLED CH OFF**), there may be as many as eight raw arrays. These arrays are directly accessible via GPIB. Notice that the numbers here are still complex pairs.

Raw Arrays

Raw arrays contain the pre-raw data which has sampler and attenuator offset applied.

Vector Error-correction (Accuracy Enhancement)

Error-correction is performed next, if a measurement calibration has been performed and correction is activated. Error-correction removes repeatable systematic errors (stored in the error coefficient arrays) from the raw arrays. This can vary from simple vector normalization to full 12-term error-correction.

The results of error-correction are stored in the data arrays as complex number pairs. These are subsequently used whenever correction is on, and are accessible via GPIB.

If the data-to-memory operation is performed, the data arrays are copied into the memory arrays.

Trace Math Operation

This operation selects either the data array, memory array, or both to continue flowing through the data processing path. In addition, the complex ratio of the two (data/memory) or the difference (data–memory) can also be selected. If memory is displayed, the data from the memory arrays goes through exactly the same processing flow path as the data from the data arrays.

Gating (Option 010 Only)

This digital filtering operation is associated with time domain transformation. Its purpose is to mathematically remove unwanted responses isolated in time. In the time domain, this can be viewed as a time-selective bandpass or bandstop filter. (If both data and memory are displayed, gating is applied to the memory trace only if gating was on when data was stored into memory.)

The Electrical Delay Block

This block involves adding or subtracting phase in proportion to frequency. This is equivalent to "line-stretching" or artificially moving the measurement reference plane. This block also includes the effects of port extensions as well as electrical delay.

Conversion

This converts the measured S-parameter data to the equivalent complex impedance (Z) or admittance (Y) values, or to inverse S-parameters (1/S).

Transform (Option 010 Only)

This transform converts frequency domain information into the time domain when it is activated. The results resemble time domain reflectometry (TDR) or impulse-response measurements. The transform uses the chirp-Z inverse fast Fourier transform (FFT) algorithm to accomplish the conversion. The windowing operation, if enabled, is performed on the frequency domain data just before the transform. (A special transform mode is available to "demodulate" CW sweep data, with time as the stimulus parameter, and display spectral information with frequency as the stimulus parameter.)

Format

This operation converts the complex number pairs into a scalar representation for display, according to the selected format. This includes group delay calculations. These formats are often easier to interpret than the complex number representation. (Polar and Smith chart formats are not affected by the scalar formatting.) It is impossible to recover the complex data after formatting, as shown in [Figure 7-2](#).

Smoothing

This noise reduction technique smoothes noise on the trace. Smoothing is also used to set the aperture for group delay measurements.

When smoothing is on, each point in a sweep is replaced by the moving average value of several adjacent (formatted) points. The number of points included depends on the smoothing aperture, which can be selected by the user. The effect is similar to video filtering. If data and memory are displayed, smoothing is performed on the memory trace only if smoothing was on when data was stored into memory.

Format Arrays

The data processing results are now stored in the format arrays. Notice that the marker values and marker functions are all derived from the format arrays in [Figure 7-2](#). Limit testing is also performed on the formatted data. The format arrays are accessible via GPIB.

Offset and Scale

These operations prepare the formatted data for display. This is where the reference line position, reference line value, and scale calculations are performed, as appropriate to the format.

Display Memory

The display memory stores the display image for presentation on the analyzer. The information stored includes graticules, annotation, and softkey labels. If user display graphics are written, these are also stored in display memory. When a print or plot is made, the information is taken from display memory.

The display is updated frequently and synchronously with the data processing operations.

Output Power

Understanding the Power Ranges

The built-in synthesized source contains a programmable step attenuator that allows you to directly and accurately set power levels in twelve different power ranges. Each range has a total span of 20 dB (15 dB, 8722ET/ES). The twelve ranges cover the instrument's full operating range. In addition, some amount of overrange and underrange is permitted beyond the stated limits. Performance outside of the range limits varies from one analyzer to another and is not specified. A power range can be selected either manually or automatically.

Automatic mode

If you select **PWR RANGE AUTO**, you can enter any power level within the total operating range of the instrument and the source attenuator will automatically switch to the corresponding range.

Each range overlaps its adjacent ranges by 15 dB, therefore, certain power levels are designated to cause the attenuator to switch to the next range so that optimum (leveled) performance is maintained. These transition points exist at -10 dB from the top of a range and at $+5$ dB from the bottom of a range. This leaves 10 dB of operating range. By turning the RPG knob with **PORT POWER** being the active function, you can hear the attenuator switch as these transitions occur. See the specifications and characteristics chapter in the reference guide for the analyzer's power limits.

Manual mode

If you select **PWR RANGE MAN**, you must first enter the power ranges menu and manually select the power range that corresponds to the power level you want to use. This is accomplished by pressing the **POWER RANGES** softkey and then selecting one of the 12 available ranges. The active power will always be reset to be within this range. In this mode, you will be able to select power levels above or below the range limits. The factory limits on setting power level are $+6$ dB above the maximum range power and -12 dB below the minimum range power. Typical performance for power overrange is 2 dB above the maximum (more at lower frequencies and less at higher frequencies) and typical under range is 12 dB. An under-range condition may cause a phase lock lost message to be displayed.

When a calibration is active, the power range selection is switched from auto to manual mode, and **PRM** appears on the display. This feature is necessary to maintain accuracy once a measurement calibration is activated.

NOTE After measurement calibration, you can change the power within a range and still maintain nearly full accuracy. In some cases better accuracy can be achieved by changing the power within a range. It can be useful to set different power levels for calibration and measurement to minimize the effects of sampler compression or noise floor.

If you decide to switch power ranges, the calibration accuracy is degraded and accuracy is no longer specified. However, the analyzer leaves the correction *on*.

The annotation Δ will be displayed whenever you change the power after calibration.

Power Coupling Options

There are two methods you can use to couple and uncouple power levels with the analyzer:

- channel coupling
- port coupling

By uncoupling the channel powers, you effectively have two separate sources. Uncoupling the test ports allows you to have different power levels on each port.

Channel coupling

CH PWR [COUPLED] toggles between coupled and uncoupled channel power. With the channel power coupled, the power levels are the same on each channel. With the channel power uncoupled, you can set different power levels for each channel. For the channel power to be uncoupled, the other channel stimulus functions must also be uncoupled (**COUPLED CH OFF**).

Test port coupling

PORT PWR [COUPLED] toggles between coupled and uncoupled test ports. With the test ports coupled, the power level is the same at each port. With the ports uncoupled, you can set a different power level at each port. This can be useful, for example, if you want to simultaneously perform a gain and reverse isolation measurement on a high-gain amplifier using the dual channel mode to display the results. In this case, you would want the power in the forward direction (S_{21}) much lower than the power in the reverse direction (S_{12}).

Sweep Time

The **SWEEP TIME []** softkey selects sweep time as the active entry and shows whether the automatic or manual mode is active. The following explains the difference between automatic and manual sweep time:

- **Manual sweep time.** As long as the selected sweep speed is within the capability of the instrument, it will remain fixed, regardless of changes to other measurement parameters. If you change measurement parameters such that the instrument can no longer maintain the selected sweep time, the analyzer will change to the fastest sweep time possible.
- **Auto sweep time.** Auto sweep time continuously maintains the fastest sweep speed possible with the selected measurement parameters.

Sweep time refers only to the time that the instrument is sweeping and taking data, and does not include the time required for internal processing of the data, retrace time, or band switching time. A sweep speed indicator ↑ is displayed on the trace for sweep times longer than 1.0 second. For sweep times equal to or faster than 1.0 second, the ↑ indicator appears in the status notations area at the left of the analyzer's display.

Manual Sweep Time Mode

When this mode is active, the softkey label reads **SWEEP TIME [MANUAL]**. This mode is engaged whenever you enter a sweep time greater than zero. This mode allows you to select a fixed sweep time. If you change the measurement parameters such that the current sweep time is no longer possible, the analyzer will automatically increase to the next fastest sweep time possible. If the measurement parameters are changed such that a faster sweep time is possible, the analyzer will not alter the sweep time while in this mode.

Auto Sweep Time Mode

When this mode is active, the softkey label reads **SWEEP TIME [AUTO]**. This mode is engaged whenever you enter **0** **x1** as a sweep time. Auto sweep time continuously maintains the fastest sweep time possible with the selected measurement parameters.

Minimum Sweep Time

The minimum sweep time is dependent on the following measurement parameters:

- the number of points selected
- IF bandwidth
- sweep-to-sweep averaging in dual channel display mode
- error-correction
- type of sweep

Sweep Time

In addition to the these parameters, the actual cycle time of the analyzer is also dependent on the following measurement parameters:

- smoothing
- limit test
- trace math
- marker statistics
- time domain (Option 010 only)

Refer to the specifications and characteristics chapters of the reference guide to see the minimum cycle time values for specific measurement parameters.

Source Attenuator Switch Protection

The programmable step attenuator of the source can be switched between port 1 and port 2 when the test port power is uncoupled, or between channel 1 and channel 2 when the channel power is uncoupled. To avoid premature wear of the attenuator, measurement configurations requiring continuous switching between different power ranges are not allowed.

For example, continuous switching would be required if channels 1 and 2 of the analyzer are decoupled, power levels in two different ranges are selected for each channel, and dual channel display is engaged. To prevent continuous switching between the two power ranges, the analyzer automatically engages the test set hold mode after measuring both channels once. The active channel continues to be updated each sweep while the inactive channel is placed in the hold mode. (The status annotation τ_{sH} appears on the left side of the display.) If averaging is on, the test set hold mode does not engage until the specified number of sweeps is completed. The **MEASURE RESTART** and **NUMBER OF GROUPS** softkeys can override this protection feature.

Allowing Repetitive Switching of the Attenuator

The **MEASURE RESTART** and **NUMBER OF GROUPS** softkeys allow measurements which demand repetitive switching of the step attenuator. Use these softkeys with caution; repetitive switching can cause premature wearing of the attenuator.

- **MEASURE RESTART** causes one measurement to occur before activating the test set hold mode.
- **NUMBER OF GROUPS** causes a specified number of measurements to occur before activating the test set hold mode.

Channel Stimulus Coupling

COUPLED CH on OFF toggles the channel coupling of stimulus values. With **COUPLED CH ON** (the preset condition), both channels have the same stimulus values. (The inactive channel takes on the stimulus values of the active channel.)

In the stimulus coupled mode, the following parameters are coupled:

- frequency
- number of points
- source power
- number of groups
- IF bandwidth
- sweep time
- trigger type
- gating parameters
- sweep type
- power meter calibration

Coupling of stimulus values for the two channels is independent of **DUAL CHAN on OFF** in the display menu and **MARKERS: UNCOUPLED** in the marker mode menu. **COUPLED CH OFF** activates an alternate sweep function when dual channel display is on. In this mode, the analyzer alternates between the two sets of stimulus values and displays the measurement data of both channels.

Sweep Types

The following sweep types will function with the interpolated error-correction feature (described in [“Interpolated Error Correction” on page 6-8](#)):

- linear frequency
- power sweep
- CW time

The following sweep types will not function with the interpolated error correction feature:

- logarithmic frequency sweep
- list frequency sweep

Linear Frequency Sweep (Hz)

The **LIN FREQ** softkey activates a linear frequency sweep that is displayed on a standard graticule with ten equal horizontal divisions. This is the preset default sweep type.

For a linear sweep, sweep time is combined with the channel's frequency span to compute a source sweep rate:

$$\text{sweep rate} = (\text{frequency span}) / (\text{sweep time})$$

Since the sweep time may be affected by various factors, the equation provided here is merely an indication of the ideal (fastest) sweep rate. If the user-specified sweep time is greater than 15 ms times the number of points, the sweep changes from a continuous ramp sweep to a stepped CW sweep. Also, for 10 Hz or 30 Hz IF bandwidths, the sweep is automatically converted to a stepped CW sweep.

In the linear frequency sweep mode, it is possible, with Option 010, to transform the data for time domain measurements using the inverse Fourier transform technique.

Logarithmic Frequency Sweep (Hz)

The **LOG FREQ** softkey activates a logarithmic frequency sweep mode. The source is stepped in logarithmic increments and the data is displayed on a logarithmic graticule. This is slower than a continuous sweep with the same number of points, and the entered sweep time may therefore be changed automatically. For frequency spans of less than two octaves, the sweep type automatically reverts to linear sweep.

Stepped List Frequency Sweep (Hz)

The **LIST FREQ [STEPPED]** softkey activates a stepped list frequency sweep, one of two list frequency sweep modes. The stepped list mode allows the analyzer to sweep a list of arbitrary frequency points. This list is defined and modified using the edit list menu and the edit subsweep menu. Up to 30 frequency subsweeps (called "segments") of several different types can be specified, for a maximum total of 1601 points.

NOTE Earlier 8719, 8720, and 8722 models allowed a maximum of 1632 points, but this value was reduced to 1601 to add the 4 channels in the 4-parameter display feature.

One list is common to both channels. Once a frequency list has been defined and a measurement calibration performed on the full frequency list, one or all of the frequency segments can be measured and displayed without loss of calibration.

When the **LIST FREQ [STEPPED]** key is pressed, the network analyzer sorts all the defined frequency segments into CW points in order of increasing frequency. It then measures each point and displays a single trace that is a composite of all data taken. If duplicate frequencies exist, the analyzer makes multiple measurements on identical points to maintain the specified number of points for each subsweep. Since the frequency points may not be distributed evenly across the display, the display resolution may be uneven, and more compressed in some parts of the trace than in others. However, the stimulus and response readings of the markers are always accurate. Because the list frequency sweep is a stepped CW sweep, the sweep time is slower than for a continuous sweep with the same number of points.

Segment Menu

The **LIST FREQ [STEPPED]** softkey provides access to the segment menu, which allows you to select any single segment (**SINGLE SEG SWEEP**) in the frequency list or all of the segments (**ALL SEGS SWEEP**) in the frequency list.

See the following information on how to enter or modify the list frequencies. If no list has been entered, the message CAUTION: LIST TABLE EMPTY is displayed. A tabular printout of the frequency list data can be obtained using the **LIST VALUES** function in the copy menu.

Stepped Edit List Menu

The **EDIT LIST** softkey within the sweep type menu provides access to the edit list menu.

This menu is used to edit the list of frequency segments (subsweeps) defined with the edit subsweep menu, described next. Up to 30 frequency subsweeps can be specified, for a maximum of 1601 points. The segments do not have to be entered in any particular order: the analyzer automatically sorts them and shows them on the display in increasing order of start frequency. This menu determines which entry on the list is to be modified, while the edit subsweep menu is used to make changes in the frequency or number of points of the selected entry.

Stepped Edit Subsweep Menu

Using the **EDIT** or **ADD** softkey within the edit list menu will display the edit subsweep menu. This menu lets you select measurement frequencies arbitrarily. Using this menu it is possible to define the exact frequencies to be measured on a point-by-point basis. For example, the sweep could include 100 points in a narrow passband, 100 points across a broad stop band, and 50 points across the third harmonic response. The total sweep is defined with a list of subsweeps.

The frequency subsweeps, or segments, can be defined in any of the following terms:

- start/stop/number of points
- start/stop/step
- center/span/number of points

- center/span/step
- CW frequency

The subsweeps can overlap, and do not have to be entered in any particular order. The analyzer sorts the segments automatically and lists them on the display in order of increasing start frequency, even if they are entered in center/span format. If duplicate frequencies exist, the analyzer makes multiple measurements on identical points to maintain the specified number of points for each subsweep. The data is shown on the display as a single trace that is a composite of all data taken. The trace may appear uneven because of the distribution of the data points, but the frequency scale is linear across the total range.

Once the list frequencies have been defined or modified, the list frequency sweep mode can be selected with the **LIST FREQ [STEPPED]** softkey in the sweep type menu. The frequency list parameters can also be saved with an instrument state.

Swept List Frequency Sweep (Hz)

The **LIST FREQ [SWEPT]** softkey activates a swept list frequency sweep, one of two list frequency sweep modes. The swept list mode allows the analyzer to sweep a list of arbitrary frequency points which are defined and modified in a way similar to the stepped list mode.

However, this mode takes data while *sweeping* through the defined frequency points, increasing throughput by up to 6 times over a stepped sweep. In addition, this mode allows the test port power and IF bandwidth to be set independently for each segment that is defined. The only restriction is that you cannot specify overlapping frequency segments.

Similar to stepped list mode, the **LIST FREQ [SWEPT]** softkey also provides access to the segment menu. However, swept list mode expands the way segments can be defined. Refer to the following information on how to enter or modify the list segments.

Swept Edit List Menu

The **EDIT LIST** softkey within the sweep type menu provides access to the edit list menu. The function of this menu is the same as in the stepped list mode.

Swept Edit Subsweep Menu

Using the **EDIT** or **ADD** softkey within the edit list menu will display the edit subsweep menu. This menu lets you select measurement frequencies arbitrarily. Using this menu it is possible to define the exact frequencies to be measured on a point-by-point basis at specific power levels and IF bandwidth settings. The total sweep is defined with a list of subsweeps.

The frequency subsweeps, or segments, can be defined in any of the following terms:

- start/stop/number of points/power/IFBW
- start/stop/step/power/IFBW
- center/span/number of points/power/IFBW
- center/span/step/power/IFBW

See “Setting Segment Power” and “Setting Segment IF Bandwidth” on page 7-19 for information on how to set the segment power and IF bandwidth.

The subsweeps may be entered in any particular order but they cannot overlap. The analyzer sorts the segments automatically and lists them on the display in order of increasing start frequency, even if they are entered in center/span format. The data is shown on the display as a single trace that is a composite of all data taken. The trace may appear uneven because of the distribution of the data points, but the frequency scale is linear across the total range.

Once the list frequencies have been defined or modified, the list frequency sweep mode can be selected with the **LIST FREQ [SWEPT]** softkey in the sweep type menu. The frequency list parameters can also be saved with an instrument state.

Setting Segment Power

To enable the **SEGMENT POWER** function, you must first select **LIST POWER ON off** in the edit subsweep menu. List power is off by default and the asterisks that appear in the "power" column of the list table indicate that power for the sweep is being set by the normal analyzer power controls.

The power settings for all segments are restricted to a single power range. This prevents the attenuator from switching to different settings mid-sweep. Select the power range and then edit the list table to specify the segment powers. If the power range is selected after the list has been defined, the list settings may be affected.

When analyzer port power is uncoupled, the segment power level can be set independently for each port. To do this, you must first select a measurement parameter to activate the port whose power you want to set. For example, select S11 to set port 1 power, or S22 to set port 2 power. (Notice that the list mode table will only display the currently selected port in the table. This is due to restricted display space.)

When analyzer port power is uncoupled, the **LIST POWER ON off** softkey can also be set independently for each port. For example, you may choose to set **LIST POWER ON off** for forward measurements and **LIST POWER on OFF** for reverse measurements. In this case, the power would be set according to values in the list when measuring the forward parameters. When measuring the reverse parameters, the power would be set according to the normal analyzer power controls.

Setting Segment IF Bandwidth

To enable the **SEGMENT IF BW** function, you must first select **LIST IF BW ON off** in the edit subsweep menu. List IF bandwidth is off by default and the asterisks that appear in the "IFBW" column of the list table indicate that the IF bandwidth for the sweep is being set by the normal analyzer controls.

Narrow IF bandwidths require more data samples per point and thus slow down the measurement time. Selectable IF bandwidths can increase the throughput of the measurement by allowing you to specify narrow bandwidths only where needed.

Power Sweep (dBm)

The **POWER SWEEP** softkey turns on a power sweep mode that is used to characterize power-sensitive circuits. In this mode, power is swept at a single frequency, from a start power value to a stop power value, selected using the **Start** and **Stop** keys and the entry block. This feature is convenient for such measurements as gain compression or AGC (automatic gain control) slope. To set the frequency of the power sweep, use **CW FREQ** in the stimulus menu.

The span of the swept power is limited to being equal to or within one of the eight pre-defined power ranges. The attenuator will not switch to a different power range while in the power sweep mode. Therefore, when performing a power sweep, power range selection will automatically switch to the *manual* mode.

In power sweep, the entered sweep time may be automatically changed if it is less than the minimum required for the current configuration (number of points, IF bandwidth, averaging, etc.).

CW Time Sweep (Seconds)

The **CW TIME** softkey turns on a sweep mode similar to an oscilloscope. The analyzer is set to a single frequency, and the data is displayed versus time. The frequency of the CW time sweep is set with **CW FREQ** in the stimulus menu. In this sweep mode, the data is continuously sampled at precise, uniform time intervals determined by the sweep time and the number of points minus 1. The entered sweep time may be automatically changed if it is less than the minimum required for the current instrument configuration.

In time domain using Option 010, the CW time mode data is translated to frequency domain, and the x-axis becomes frequency. In this mode, the instrument can be used as a spectrum analyzer to measure signal purity, or for low frequency (<1 kHz) analysis of amplitude or pulse modulation signals.

Selecting Sweep Modes

In addition to the previous sweep types, there are also two different sweep modes. These can be accessed through the correction menu by pressing **Cal** **MORE** **ALTERNATE A and B** or **CHOP A and B**.

S-Parameters

The **Meas** key accesses the S-parameter menu which contains softkeys that can be used to select the parameters or inputs that define the type of measurement being performed.

Understanding S-Parameters

S-parameters (scattering parameters) are a convention used to characterize the way a device modifies signal flow. A brief explanation of the S-parameters of a two-port device is provided, however, for additional details, refer to Application Notes 95-1 and 154.

S-parameters are always a ratio of two complex (magnitude and phase) quantities. S-parameter notation identifies these quantities using the numbering convention:

S out in

where the first number (out) refers to the test-device port where the signal is emerging and the second number (in) is the test-device port where the signal is incident. For example, the S-parameter S_{21} identifies the measurement as the complex ratio of the signal emerging at the test device's port 2 to the signal incident at the test device's port 1.

Figure 7-3 is a representation of the S-parameters of a two-port device, together with an equivalent flowgraph. In the illustration, "a" represents the signal entering the device and "b" represents the signal emerging. Note that a and b are not related to the A and B input ports on the analyzer.

Figure 7-3 S-Parameters of a Two-Port Device

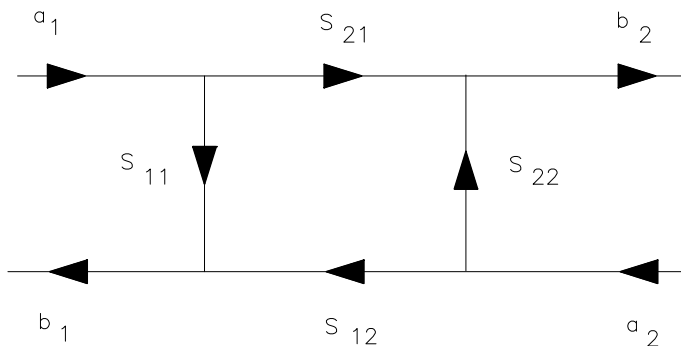
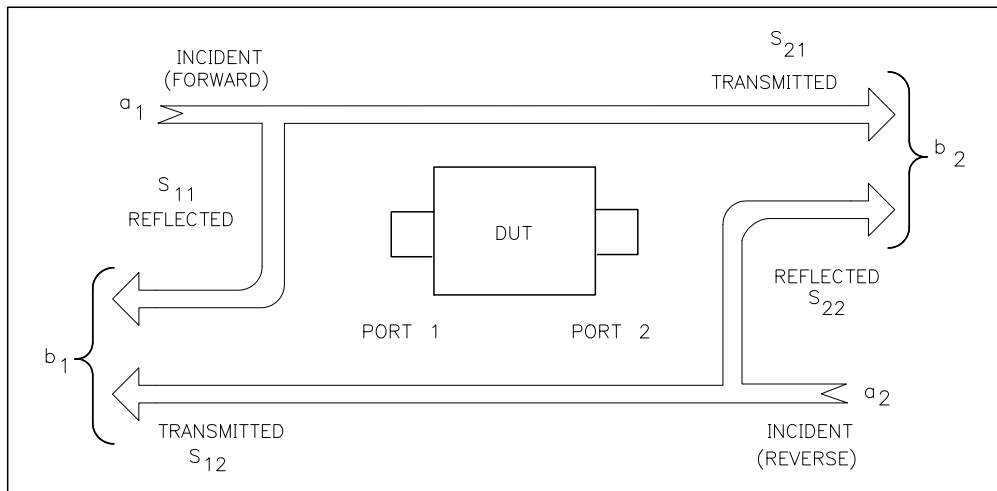

S-parameters are exactly equivalent to these more common description terms, requiring only that the measurements be taken with all test device ports properly terminated.

S-Parameter	Definition	Test Set Description	Direction
S_{11}	b_1/a_1 $a_2 = 0$	Input reflection coefficient	FWD
S_{21}	b_2/a_1 $a_2 = 0$	Forward gain	FWD
S_{12}	b_1/a_2 $a_1 = 0$	Reverse Gain	REV
S_{22}	b_2/a_2 $a_1 = 0$	Output reflection coefficient	REV

The S-Parameter Menu

The S-parameter menu allows you to define the input ports and test set direction for S-parameter measurements. The analyzer automatically switches the direction of the measurement according to the selections you made in this menu. Therefore, the analyzer can measure all four S-parameters with a single connection. The S-parameter being measured is labeled at the top left corner of the display.

The S-parameter menu of the ES model analyzer contains the following softkeys:

- **Refl: FWD S11 (A/R)**
- **Trans: FWD S21 (B/R)**
- **Trans: REV S12 (A/R)**
- **Refl: REV S22 (B/R)**
- **ANALOG IN Aux Input**
- **CONVERSION []** accesses the conversion menu.
- **INPUT PORTS** accesses the input ports menu.

The S-parameter menu of the ET model analyzer contains the following softkeys:

- **REFLECTION**
- **TRANSMISSN**
- **ANALOG IN Aux Input**
- **CONVERSION []** accesses the conversion menu.
- **INPUT PORTS** accesses the input ports menu.

Analog In Menu

This menu allows you to monitor voltage and frequency nodes, using the analog bus and internal counter. For more information, refer to the "Service Menus and Error Messages" chapter in the service guide.

Conversion Menu

This menu converts the measured reflection or transmission data to the equivalent complex impedance (Z) or admittance (Y) values. This is not the same as a two-port Y or Z parameter conversion, as only the measured parameter is used in the equations. Two simple one-port conversions are available, depending on the measurement configuration.

An S_{11} or S_{22} trace measured as reflection can be converted to equivalent parallel impedance or admittance using the model and equations shown in [Figure 7-4](#).

Figure 7-4 Reflection Impedance and Admittance Conversions

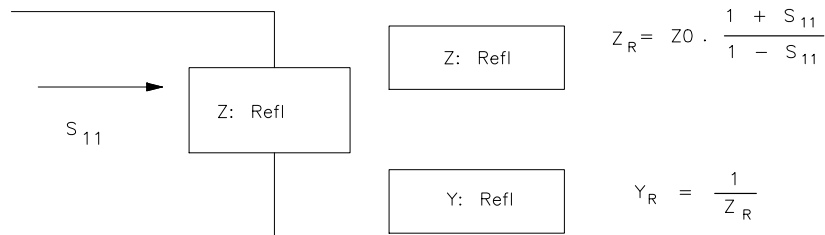

pg640d

In a transmission measurement, the data can be converted to its equivalent series impedance or admittance using the model and equations shown in [Figure 7-5](#).

Figure 7-5 Transmission Impedance and Admittance Conversions

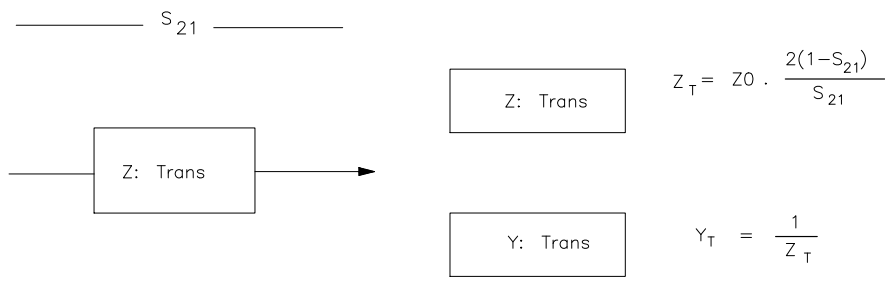

pg641d

NOTE Avoid the use of Smith chart, SWR, and delay formats for display of Z and Y conversions, as these formats are not easily interpreted.

Input Ports Menu

This menu allows you to define the input ports for power ratio measurements, or a single input for magnitude only measurements of absolute power. You cannot use single inputs for phase or group delay measurements, or any measurements with averaging activated.

Analyzer Display Formats

The **Format** key accesses the format menu. This menu allows you to select the appropriate display format for the measured data.

The analyzer automatically changes the units of measurement to correspond with the displayed format. Special marker menus are available for the polar and Smith formats, each providing several different marker types for readout of values.

The selected display format of a particular S-parameter or input is assigned to that parameter. Thus if different S-parameters are measured, even if only one channel is used, each parameter is shown in its selected format each time it is displayed.

The following illustrations show a reflection measurement of a bandpass filter displayed in each of the available formats.

Log Magnitude Format

The **LOG MAG** softkey displays the log magnitude format. This is the standard Cartesian format used to display magnitude-only measurements of insertion loss, return loss, or absolute power in dB versus frequency. The bandpass filter reflection data in a log magnitude format is illustrated in [Figure 7-6](#).

Figure 7-6 Log Magnitude Format

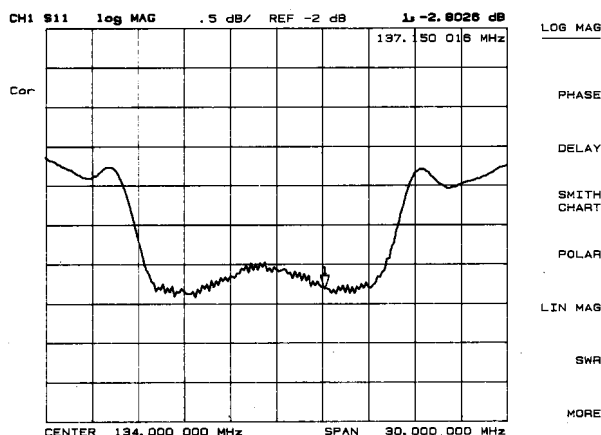

pg6184_c

Phase Format

The **PHASE** softkey displays a Cartesian format of the phase portion of the data, measured in degrees. This format displays the phase shift versus frequency. The phase response of the same filter in a phase-only format is illustrated in [Figure 7-7](#).

Figure 7-7 Phase Format

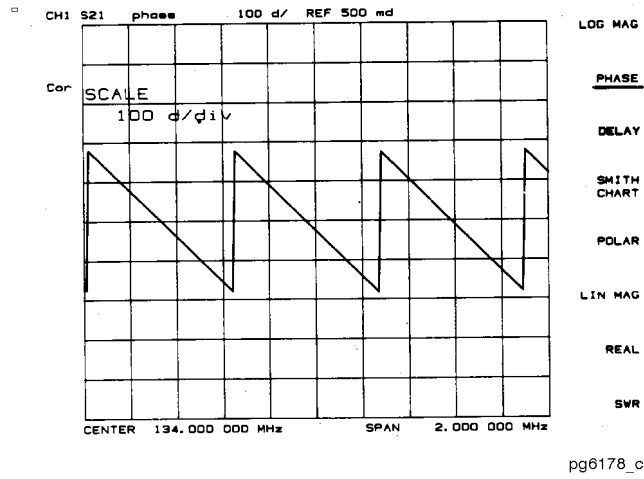

Group Delay Format

The **DELAY** softkey selects the group delay format, with marker values given in seconds. The bandpass filter response formatted as group delay is shown in Figure 7-8. Group delay principles are described in the next few pages.

Figure 7-8 Group Delay Format

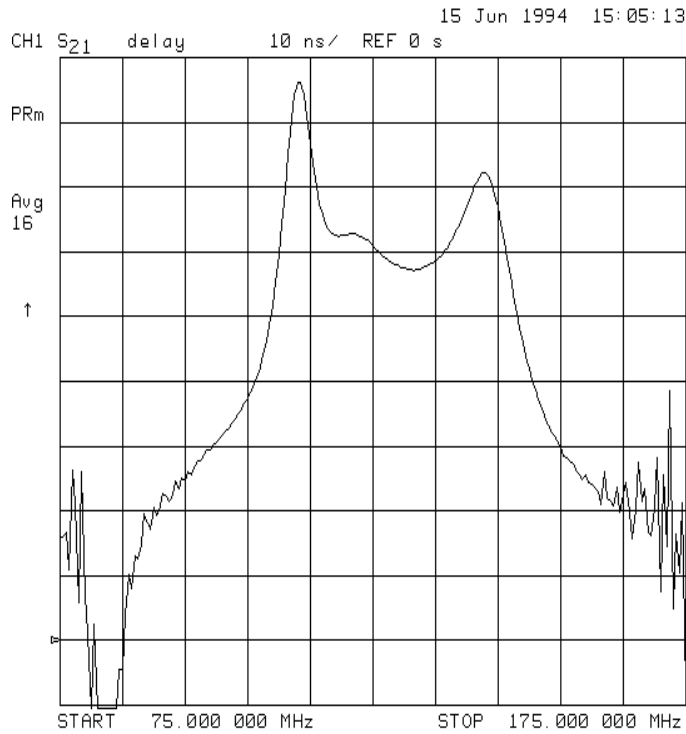

Smith Chart Format

The **SMITH CHART** softkey displays a Smith chart format. Refer to [Figure 7-9](#). This is used in reflection measurements to provide a readout of the data in terms of impedance. The intersecting dotted lines on the Smith chart represent constant resistance and constant reactance values, normalized to the characteristic impedance, Z_0 , of the system. Reactance values in the upper half of the Smith chart circle are positive (inductive) reactance, and those in the lower half of the circle are negative (capacitive) reactance. The default marker readout is in ohms (Ω) to measure resistance and reactance ($R+jX$). Additional marker types are available in the Smith marker menu.

The Smith chart is most easily understood with a full scale value of 1.0. If the scale per division is less than 0.2, the format switches automatically to polar.

If the characteristic impedance of the system is not 50 ohms, modify the impedance value recognized by the analyzer by pressing **Cal** **MORE** **SET Z0** (the impedance value) **(x1)**.

An inverted Smith chart format for admittance measurements is also available. This is shown in [Figure 7-9](#). Access this by selecting **SMITH CHART** in the format menu, and pressing **Marker Fctn** **MKR MODE MENU** **SMITH MKR MENU** **G+jB MKR**. The Smith chart is inverted and marker values are read out in siemens (S) to measure conductance and susceptance ($G+jB$).

Figure 7-9 Standard and Inverse Smith Chart Formats

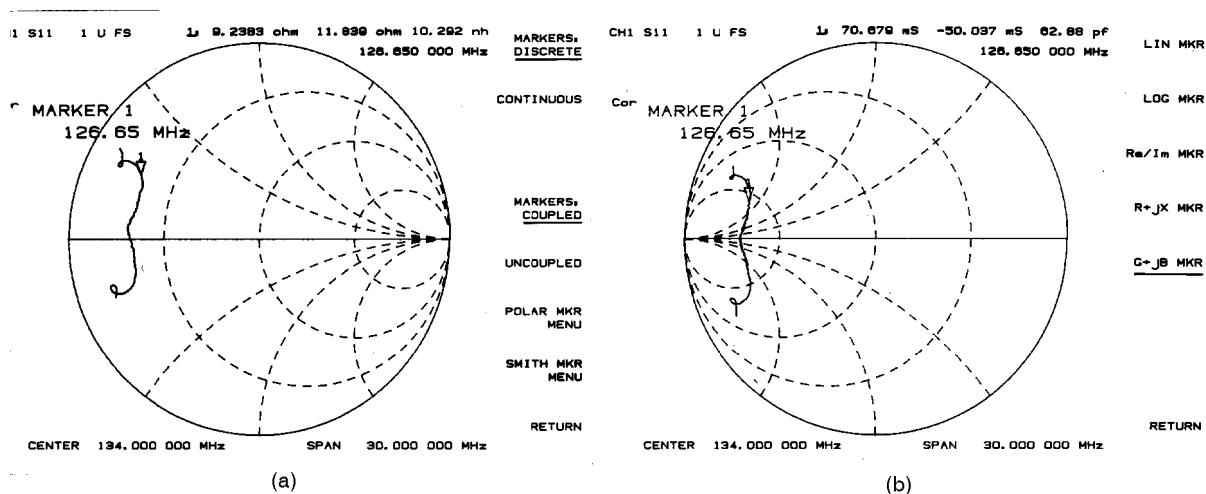

pg6176_c

Polar Format

The **POLAR** softkey displays a polar format as shown in [Figure 7-10](#). Each point on the polar format corresponds to a particular value of both magnitude and phase. Quantities are read vectorally: the magnitude at any point is determined by its displacement from the center (which has zero value), and the phase by the angle counterclockwise from the positive x-axis. Magnitude is scaled in a linear fashion, with the value of the outer circle usually set to a ratio value of 1. Since there is no frequency axis, frequency information is read from the markers.

The default marker readout for the polar format is in linear magnitude and phase. A log magnitude marker and a real/imaginary marker are available in the polar marker menu.

Figure 7-10 Polar Format

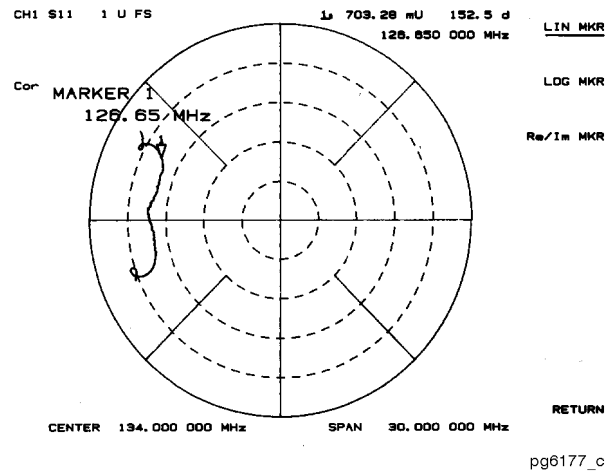

Linear Magnitude Format

The **LIN MAG** softkey displays the linear magnitude format as shown in [Figure 7-11](#). This is a Cartesian format used for unitless measurements such as reflection coefficient magnitude ρ or transmission coefficient magnitude τ , and for linear measurement units. It is used for display of conversion parameters and time domain transform data.

Figure 7-11 Linear Magnitude Format

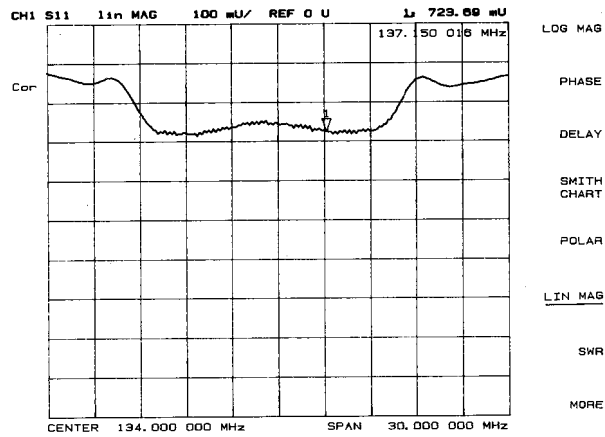

pg6174_c

SWR Format

The **SWR** softkey reformats a reflection measurement into its equivalent SWR (standing wave ratio) value. See Figure 7-12. SWR is equivalent to $(1 + \rho)/(1 - \rho)$, where ρ is the reflection coefficient. Note that the results are valid only for reflection measurements. If the SWR format is used for measurements of S_{21} or S_{12} the results are not valid.

Figure 7-12 Typical SWR Display

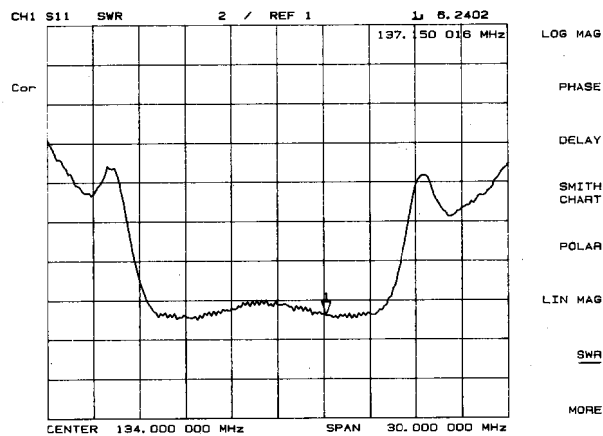

pg6175_c

Real Format

The **REAL** softkey displays only the real (resistive) portion of the measured data on a Cartesian format. See [Figure 7-13](#). This is similar to the linear magnitude format, but can show both positive and negative values. It is primarily used for analyzing responses in the time domain, and also to display an auxiliary input voltage signal for service purposes.

Figure 7-13 Real Format

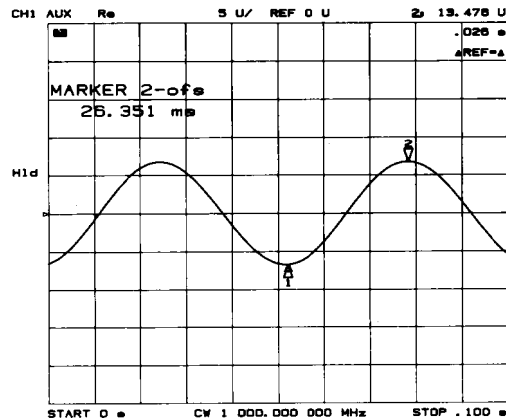

pg6173_c

Imaginary Format

The **IMAGINARY** softkey displays only the imaginary (reactive) portion of the measured data on a Cartesian format. This format is similar to the real format except that reactance data is displayed on the trace instead of resistive data.

Group Delay Principles

For many networks, the amount of insertion phase is not as important as the linearity of the phase shift over a range of frequencies. The analyzer can measure this linearity and express it in two different ways: directly, as deviation from linear phase, or as group delay, a derived value.

Group delay is the measurement of signal transmission time through a test device. It is defined as the derivative of the phase characteristic with respect to frequency. Since the derivative is basically the instantaneous slope (or rate of change of phase with respect to frequency), a perfectly linear phase shift results in a constant slope, and therefore a constant group delay. See [Figure 7-14](#).

Figure 7-14 Constant Group Delay

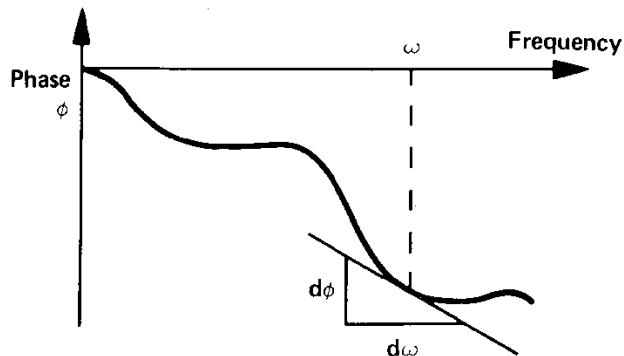

pg6182_c

Note, however, that the phase characteristic typically consists of both linear and higher order (deviations from linear) components. The linear component can be attributed to the electrical length of the test device, and represents the average signal transit time. The higher order components are interpreted as variations in transit time for different frequencies, and represent a source of signal distortion. See Figure 7-15.

Figure 7-15 Higher Order Phase Shift

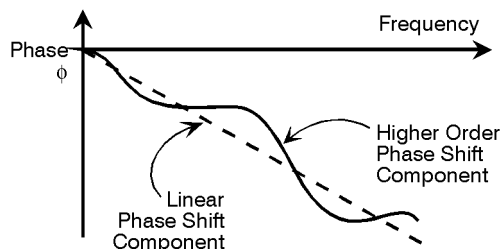

$$\begin{aligned} \text{Group Delay} = \tau_g &= \frac{-d\phi}{d\omega} && \phi \text{ in Radians} \\ &&& \omega \text{ in Radians/Sec} \\ &= \frac{-1}{360^\circ} \cdot \frac{d\phi}{df} && \phi \text{ in Degrees} \\ &&& f \text{ in Hz } (\omega = 2\pi f) \end{aligned}$$

pb6115d

The analyzer computes group delay from the phase slope. Phase data is used to find the phase change, $\Delta \Phi$ over a specified frequency aperture, Δf , to obtain an approximation for the rate of change of phase with frequency. Refer to Figure 7-16. This value, $(\tau)_g$, represents the group delay in seconds assuming linear phase change over Δf . It is important that $\Delta \Phi$ be $\leq 180^\circ$, or errors will result in the group delay data. These errors can be significant for long delay devices. You can verify that $\Delta \Phi$ is $\leq 180^\circ$ by increasing the number of points or narrowing the frequency span (or both) until the group delay data no longer changes.

Figure 7-16 Rate of Phase Change Versus Frequency

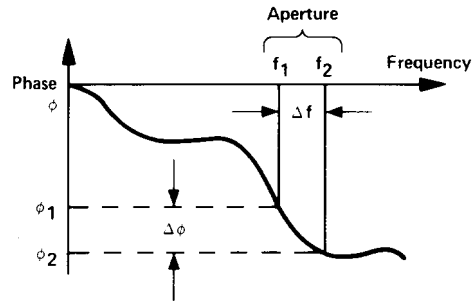

pg6180_c

When deviations from linear phase are present, changing the frequency step can result in different values for group delay. Note that in this case the computed slope varies as the aperture Δf is increased. See [Figure 7-17](#). A wider aperture results in loss of the fine grain variations in group delay. This loss of detail is the reason that in any comparison of group delay data, it is important to know the aperture that was used to make the measurement.

Figure 7-17 Variations in Frequency Aperture

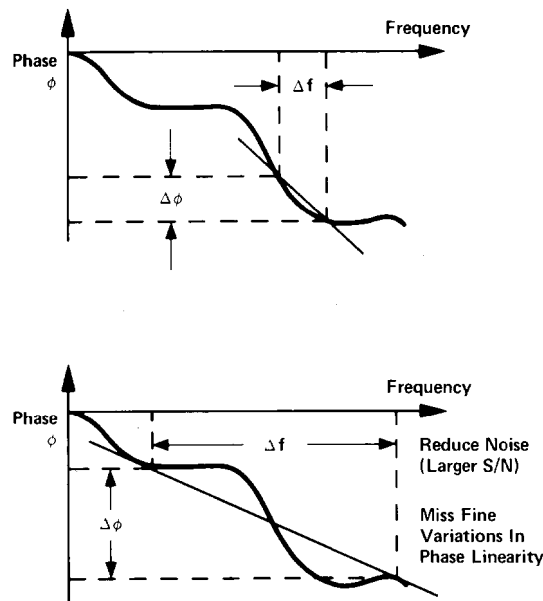

pg6181_c

In determining the group delay aperture, there is a trade-off between resolution of fine detail and the effects of noise. Noise can be reduced by increasing the aperture, but this will tend to smooth out the fine detail. More detail will become visible as the aperture is decreased, but the noise will also increase, possibly to the point of obscuring the detail. A good practice is to use a smaller aperture to assure that small variations are not missed, then increase the aperture to smooth the trace.

Operating Concepts

Analyzer Display Formats

The default group delay aperture is the frequency span divided by the number of points across the display. To set the aperture to a different value, turn on smoothing in the average menu, and vary the smoothing aperture. The aperture can be varied up to 20% of the span swept.

Group delay measurements can be made on linear frequency, log frequency, or list frequency sweep types (not in CW or power sweep). Group delay aperture varies depending on the frequency spacing and point density, therefore the aperture is not constant in log and list frequency sweep modes. In list frequency mode, extra frequency points can be defined to ensure the desired aperture.

To obtain a readout of aperture values at different points on the trace, turn on a marker. Then press **Avg**. **SMOOTHING APERTURE** . Smoothing aperture becomes the active function, and as the aperture is varied its value in Hz is displayed beneath the active entry area.

Electrical Delay

The **ELECTRICAL DELAY** softkey adjusts the electrical delay to balance the phase of the test device. This softkey must be used in conjunction with **COAXIAL DELAY** or **WAVEGUIDE DELAY** (with cut-off frequency) in order to identify which type of transmission line the delay is being added to. These softkeys can be accessed by pressing the **Scale Ref** key.

Electrical delay simulates a variable length lossless transmission line, which can be added to or removed from a receiver input to compensate for interconnecting cables, etc. This function is similar to the mechanical or analog "line stretchers" of other network analyzers. Delay is annotated in units of time with secondary labeling in distance for the current velocity factor.

With this feature, and with **MARKER → DELAY** (refer to "Setting the Electrical Delay" on page 1-37), an equivalent length of air-filled, lossless transmission line is added or subtracted according to the following formula:

$$Length (meters) = \frac{\Phi}{(Freq (MHz) \times 1.20083)}$$

Once the linear portion of the test device's phase has been removed, the equivalent length of the lossless, transmission line can be read out in the active marker area. If the average relative permittivity (ϵ_r) of the test device is known over the frequency span, the length calculation can be adjusted to indicate the actual length of the test device more closely. This can be done by entering the relative velocity factor for the test device using the calibrate more menu. The relative velocity factor for a given dielectric can be calculated by:

$$Velocity Factor = \frac{1}{\sqrt{\epsilon_r}}$$

assuming a relative permeability of 1.

Noise Reduction Techniques

The **(Avg)** key is used to access three different noise reduction techniques: sweep-to-sweep averaging, display smoothing, and variable IF bandwidth. All of these can be used simultaneously. Averaging and smoothing can be set independently for each channel, and the IF bandwidth can be set independently if the stimulus is uncoupled.

Averaging

Averaging computes each data point based on an exponential average of consecutive sweeps weighted by a user-specified averaging factor. Each new sweep is averaged into the trace until the total number of sweeps is equal to the averaging factor, for a fully averaged trace. Each point on the trace is the vector sum of the current trace data and the data from the previous sweep. A high averaging factor gives the best signal-to-noise ratio, but slows the trace update time. Doubling the averaging factor reduces the noise by 3 dB. Averaging is used for ratioed measurements: if it is attempted for a single-input measurement (e.g. A or B), the message CAUTION: AVERAGING INVALID ON NON-RATIO MEASURE is displayed. The effect of averaging on a log magnitude format trace is shown in [Figure 7-18](#).

NOTE If you switch power ranges with averaging on, the average will restart.

Figure 7-18 Effect of Averaging on a Trace

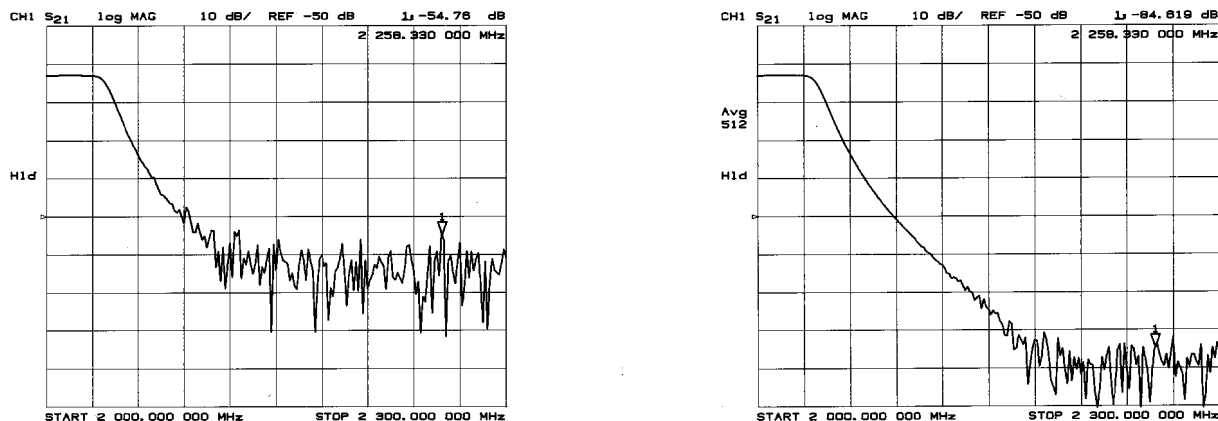

pg6171_c

Smoothing

Smoothing (similar to video filtering) averages the formatted active channel data over a portion of the displayed trace. Smoothing computes each displayed data point based on one sweep only, using a moving average of several adjacent data points for the current sweep. The smoothing aperture is a percent of the swept stimulus span, up to a maximum of 20%.

Rather than lowering the noise floor, smoothing finds the mid-value of the data. Use it to reduce relatively small peak-to-peak noise values on broadband measured data. Use a sufficiently high number of display points to avoid misleading results. Do not use smoothing for measurements of high resonance devices or other devices with wide trace variations, as it will introduce errors into the measurement.

Smoothing is used with Cartesian and polar display formats. It is also the primary way to control the group delay aperture, given a fixed frequency span. Refer to [“Group Delay Principles” on page 7-29](#). In polar display format, large phase shifts over the smoothing aperture will cause shifts in amplitude, since a vector average is being computed. The effect of smoothing on a log magnitude format trace is illustrated in [Figure 7-19](#).

Figure 7-19 Effect of Smoothing on a Trace

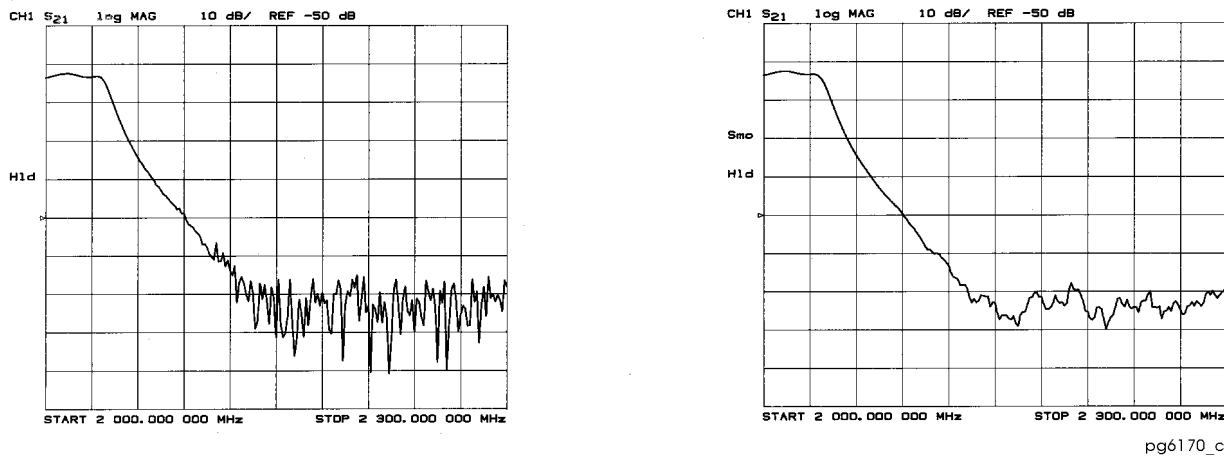

IF Bandwidth Reduction

IF bandwidth reduction lowers the noise floor by digitally reducing the receiver input bandwidth. It works in all ratio and non-ratio modes. It has an advantage over averaging as it reliably filters out unwanted responses such as spurs, odd harmonics, higher frequency spectral noise, and line-related noise. Sweep-to-sweep averaging, however, is better at filtering out very low frequency noise. A tenfold reduction in IF bandwidth lowers the measurement noise floor by about 10 dB. Bandwidths less than 300 Hz provide better harmonic rejection than higher bandwidths.

Another difference between sweep-to-sweep averaging and variable IF bandwidth is the sweep time. Averaging displays the first complete trace faster but takes several sweeps to reach a fully averaged trace. IF bandwidth reduction lowers the noise floor in one sweep, but the sweep time may be slower. The difference in noise floor between a trace measured with a 3000 Hz IF bandwidth and with a 10 Hz IF bandwidth is illustrated by Figure 7-20.

Figure 7-20 IF Bandwidth Reduction

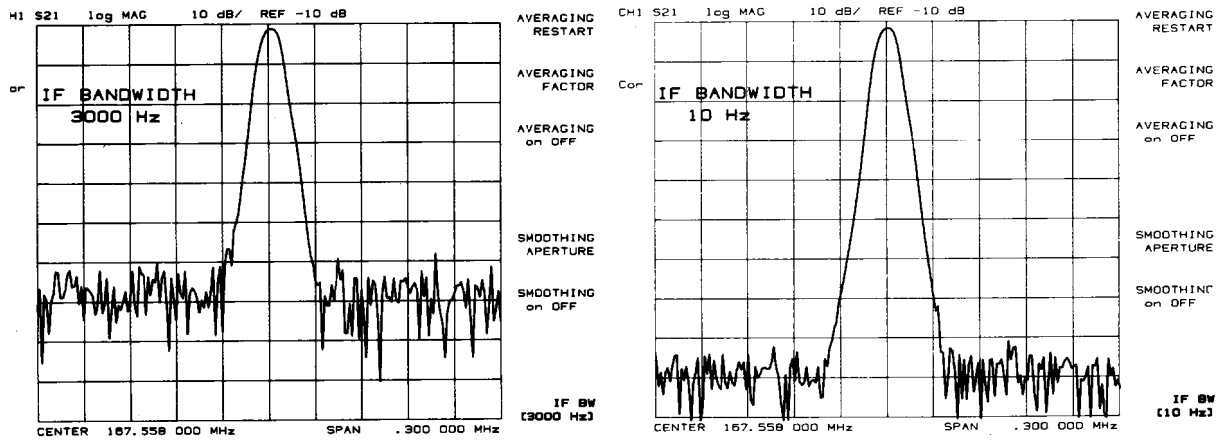

pg6168_c

NOTE Hints

Another capability that can be used for effective noise reduction is the marker statistics function, which computes the average value of part or all of the formatted trace.

If your instrument is equipped with Option 085 (High Power System), another way of increasing dynamic range is to increase the input power to the test device using a booster amplifier.

Measurement Calibration

Measurement calibration is an accuracy enhancement procedure that effectively removes the system errors that cause uncertainty in measuring a test device. It measures known standard devices, and uses the results of these measurements to characterize the system.

This section discusses the following topics:

- definition of accuracy enhancement
- causes of measurement errors
- characterization of microwave systematic errors
- effectiveness of accuracy enhancement
- ensuring a valid calibration
- modifying calibration kits
- TRL*/LRM* calibration

What Is Accuracy Enhancement?

A perfect measurement system would have infinite dynamic range, isolation, and directivity characteristics, no impedance mismatches in any part of the test setup, and flat frequency response. In any high frequency measurement there are measurement errors associated with the system that contribute uncertainty to the results. Parts of the measurement setup such as interconnecting cables and signal-separation devices (as well as the analyzer itself) all introduce variations in magnitude and phase that can mask the actual performance of the test device. Vector accuracy enhancement, also known as measurement calibration or error-correction, provides the means to simulate a nearly perfect measurement system.

For example, crosstalk due to the channel isolation characteristics of the analyzer can contribute an error equal to the transmission signal of a high-loss test device. For reflection measurements, the primary limitation of dynamic range is the directivity of the test setup. The measurement system cannot distinguish the true value of the signal reflected by the test device from the signal arriving at the receiver input due to leakage in the system. For both transmission and reflection measurements, impedance mismatches within the test setup cause measurement uncertainties that appear as ripples superimposed on the measured data.

Error-correction simulates an improved analyzer system. During the measurement calibration process, the analyzer measures the magnitude and phase responses of known standard devices, and compares the measurement with actual device data. The analyzer uses the results to characterize the system and effectively remove the system errors from the measurement data of a test device, using vector math capabilities internal to the network analyzer.

When you use a measurement calibration, the dynamic range and accuracy of the measurement are limited only by system noise and stability, connector repeatability, and the accuracy to which the characteristics of the calibration standards are known.

What Causes Measurement Errors?

Network analysis measurement errors can be separated into systematic, random, and drift errors.

Correctable systematic errors are the repeatable errors that the system can measure. These are errors due to mismatch and leakage in the test setup, isolation between the reference and test signal paths, and system frequency response.

The system cannot measure and correct for the non-repeatable random and drift errors. These errors affect both reflection and transmission measurements. Random errors are measurement variations due to noise and connector repeatability. Drift errors include frequency drift, temperature drift, and other physical changes in the test setup between calibration and measurement.

The resulting measurement is the vector sum of the test device response plus all error terms. The precise effect of each error term depends upon its magnitude and phase relationship to the actual test device response.

In most high frequency measurements the systematic errors are the most significant source of measurement uncertainty. Since each of these errors can be characterized, their effects can be effectively removed to obtain a corrected value for the test device response. For the purpose of vector accuracy enhancement, these uncertainties are quantified as directivity, source match, load match, isolation (crosstalk), and frequency response (tracking). The description of each of these systematic errors follows.

Random and drift errors cannot be precisely quantified, so they must be treated as producing a cumulative uncertainty in the measured data.

Directivity

Normally a device that can separate the reverse from the forward traveling waves (a directional bridge or coupler) is used to detect the signal reflected from the test device. Ideally the coupler would completely separate the incident and reflected signals, and only the reflected signal would appear at the coupled output, as shown in [Figure 7-21 a](#).

Figure 7-21 Directivity

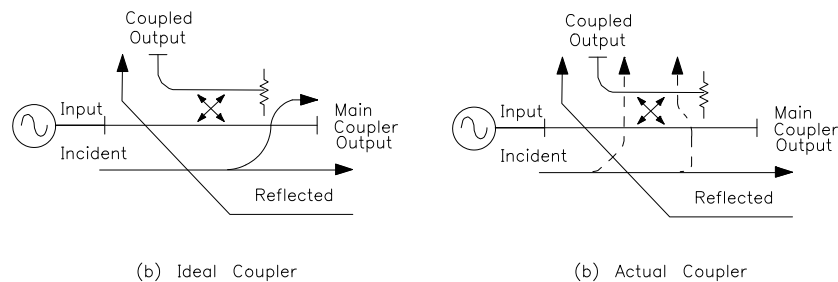

pg646d

However, an actual coupler is not perfect, as shown in Figure 7-21b. A small amount of the incident signal appears at the coupled output due to leakage as well as reflection from the termination in the coupled arm. Also, reflections from the coupler output connector appear at the coupled output, adding uncertainty to the signal reflected from the device. The figure of merit for how well a coupler separates forward and reverse waves is directivity. The greater the directivity of the device, the better the signal separation. System directivity is the vector sum of all leakage signals appearing at the analyzer receiver input. The error contributed by directivity is independent of the characteristics of the test device and it usually produces the major ambiguity in measurements of low reflection devices.

Source Match

Source match is defined as the vector sum of signals appearing at the analyzer receiver input due to the impedance mismatch at the test device looking back into the source, as well as to adapter and cable mismatches and losses. In a reflection measurement, the source match error signal is caused by some of the reflected signal from the test device being reflected from the source back toward the test device and re-reflected from the test device. This is illustrated in Figure 7-22. In a transmission measurement, the source match error signal is caused by reflection from the test device that is re-reflected from the source. Source match is most often given in terms of return loss in dB; thus the larger the number, the smaller the error.

Figure 7-22 Source Match

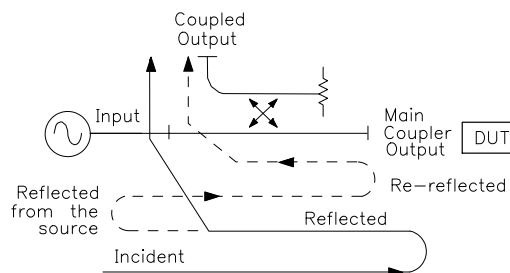

pg647d

The error contributed by source match is dependent on the relationship between the actual input impedance of the test device and the equivalent match of the source. It is a factor in both transmission and reflection measurements. Source match is a particular problem in measurements where there is a large impedance mismatch at the measurement plane. (For example, reflection devices such as filters with stop bands.)

Load Match

Load match error results from an imperfect match at the output of the test device. It is caused by impedance mismatches between the test device output port and port 2 of the measurement system. Some of the transmitted signal is reflected from port 2 back to the test device as illustrated in Figure 7-23. A portion of this wave may be re-reflected to port 2, or part may be transmitted through the device in the reverse direction to appear at port 1. If the test device has low insertion loss (for example a filter pass band), the signal reflected from port 2 and re-reflected from the source causes a significant error because the test device does not attenuate the signal significantly on each reflection. Load match is usually given in terms of return loss in dB: thus the larger the number, the smaller the error.

Figure 7-23 Load Match

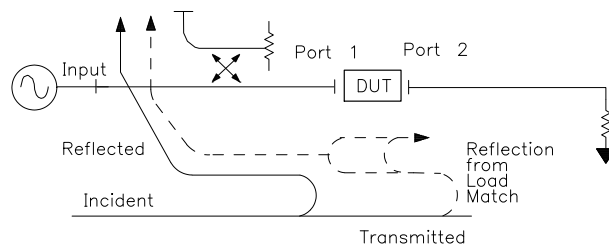

pb6114d

The error contributed by load match is dependent on the relationship between the actual output impedance of the test device and the effective match of the return port (port 2). It is a factor in all transmission measurements and in reflection measurements of two-port devices. The interaction between load match and source match is less significant when the test device insertion loss is greater than about 6 dB. However, source match and load match still interact with the input and output matches of the DUT, which contributes to transmission measurement errors. (These errors are largest for devices with highly reflective ports.)

Isolation (Crosstalk)

Leakage of energy between analyzer signal paths contributes to error in a transmission measurement, much like directivity does in a reflection measurement. Isolation is the vector sum of signals appearing at the analyzer samplers due to crosstalk between the reference and test signal paths. This includes signal leakage within the test set and in both the RF and IF sections of the receiver.

The error contributed by isolation depends on the characteristics of the test device. Isolation is a factor in high-loss transmission measurements. However, analyzer system isolation is more than sufficient for most measurements, and correction for it may be unnecessary.

For measuring devices with high dynamic range, accuracy enhancement can provide improvements in isolation that are limited only by the noise floor. Generally, the isolation falls below the noise floor, therefore, when performing an isolation calibration you should use a noise reduction function such as averaging or reduce the IF bandwidth.

Frequency Response (Tracking)

This is the vector sum of all test setup variations in which magnitude and phase change as a function of frequency. This includes variations contributed by signal-separation devices, test cables, adapters, and variations between the reference and test signal paths. This error is a factor in both transmission and reflection measurements.

For further explanation of systematic error terms and the way they are combined and represented

graphically in error models, refer to the “Characterizing Microwave Systematic Errors” on page 7-41.

Characterizing Microwave Systematic Errors

One-Port Error Model

In a measurement of the reflection coefficient (magnitude and phase) of a test device, the measured data differs from the actual, no matter how carefully the measurement is made. Directivity, source match, and reflection signal path frequency response (tracking) are the major sources of error. See Figure 7-24.

Figure 7-24 Sources of Error in a Reflection Measurement

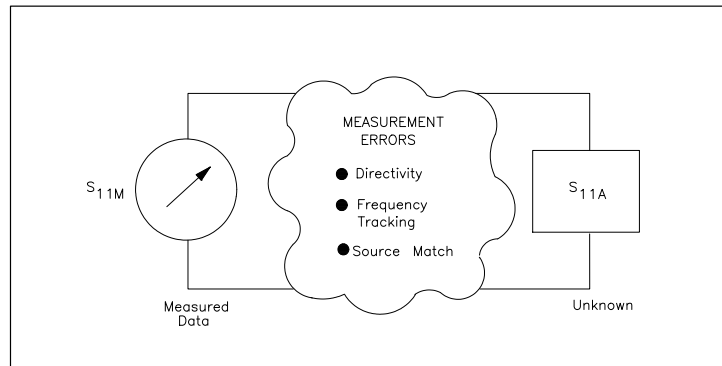

pg649d

To characterize the errors, the reflection coefficient is measured by first separating the incident signal (I) from the reflected signal (R), then taking the ratio of the two values. See [Figure 7-25](#). Ideally, (R) consists only of the signal reflected by the test device (S_{11A} , for S_{11} actual).

Figure 7-25 Reflection Coefficient

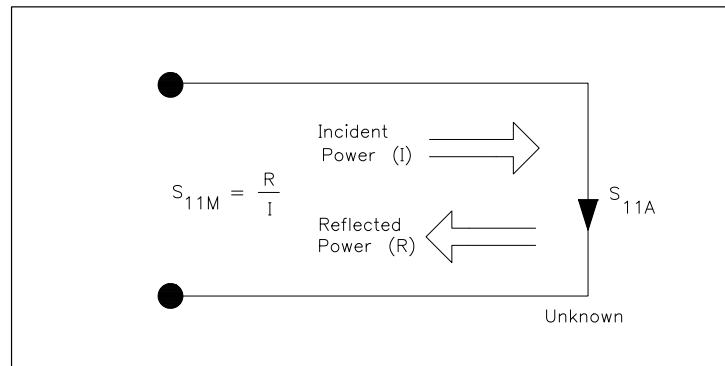

pg650d

However, all of the incident signal does not always reach the unknown. Refer to [Figure 7-26](#). Some of (I) may appear at the measurement system input due to leakage through the test set or through a signal separation device. Also, some of (I) may be reflected by imperfect adapters between a signal separation device and the measurement plane. The vector sum of the leakage and the miscellaneous reflections is the effective directivity, E_{DF} . Understandably, the measurement is distorted when the directivity signal combines vectorially with the actual reflected signal from the unknown, S_{11A} .

Figure 7-26 Effective Directivity E_{DF}

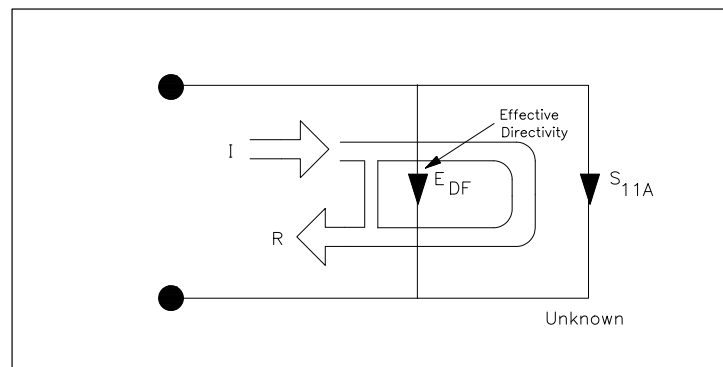

pg651d

Since the measurement system test port is never exactly the characteristic impedance (50 ohms), some of the reflected signal bounces off the test port, or other impedance transitions further down the line, and back to the unknown, adding to the original incident signal (I). This effect causes the magnitude and phase of the incident signal to vary as a function of S_{11A} and frequency. Leveling the source to produce a constant incident signal (I) reduces this error, but since the source cannot be exactly leveled at the test device input, leveling cannot eliminate all power variations.

This re-reflection effect and the resultant incident power variation are caused by the source match error, E_{SF} as shown in [Figure 7-27](#).

Figure 7-27 Source Match E_{SF}

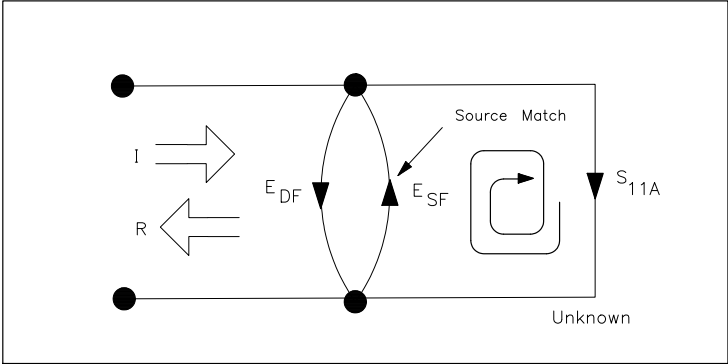

pg652d

Frequency response (tracking) error is caused by variations in magnitude and phase flatness versus frequency between the test and reference signal paths. These are due mainly to coupler roll off, imperfectly matched samplers, and differences in length and loss between the incident and test signal paths. The vector sum of these variations is the reflection signal path tracking error, E_{RF} as shown in Figure 7-28.

Figure 7-28 Reflection Tracking E_{RF}

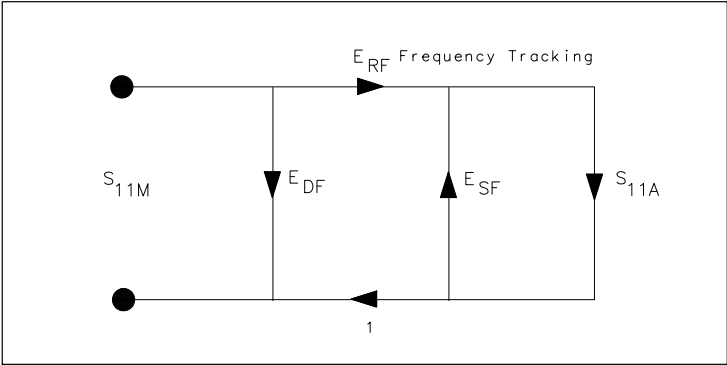

pg653d

These three errors are mathematically related to the actual data, S_{11A} , and measured data, S_{11M} , by the following equation:

$$S_{11M} = E_{DF} + \frac{(S_{11A} E_{RF})}{(1 - E_{SF} S_{11A})}$$

If the value of these three "E" errors and the measured test device response were known for each frequency, this equation could be solved for S_{11A} to obtain the actual test device response. Because each of these errors changes with frequency, their values must be known at each test frequency. These values are found by measuring the system at the measurement plane using three independent standards whose S_{11A} is

known at all frequencies.

The first standard applied is a "perfect load," which makes $S_{11A} = 0$ and essentially measures directivity. See Figure 7-29. "Perfect load" implies a reflectionless termination at the measurement plane. All incident energy is absorbed. With $S_{11A} = 0$ the equation can be solved for E_{DF} , the directivity term. In practice, of course, the "perfect load" is difficult to achieve, although very good broadband loads are available in the compatible calibration kits.

Figure 7-29 "Perfect Load" Termination

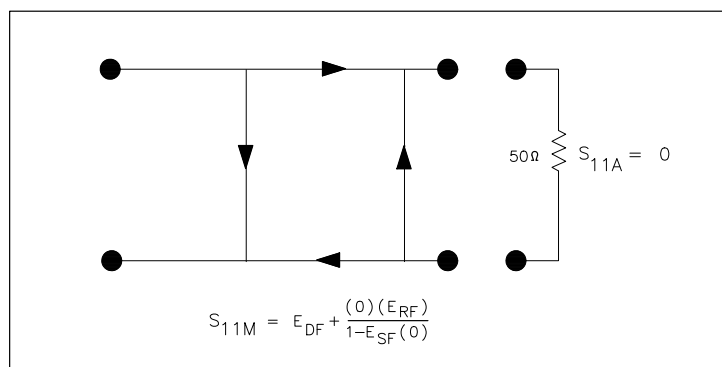

pg654d

Since the measured value for directivity is the vector sum of the actual directivity plus the actual reflection coefficient of the "perfect load," any reflection from the termination represents an error. System effective directivity becomes the actual reflection coefficient of the near "perfect load" as shown in Figure 7-30. In general, any termination having a return loss value greater than the uncorrected system directivity reduces reflection measurement uncertainty.

Figure 7-30 Measured Effective Directivity

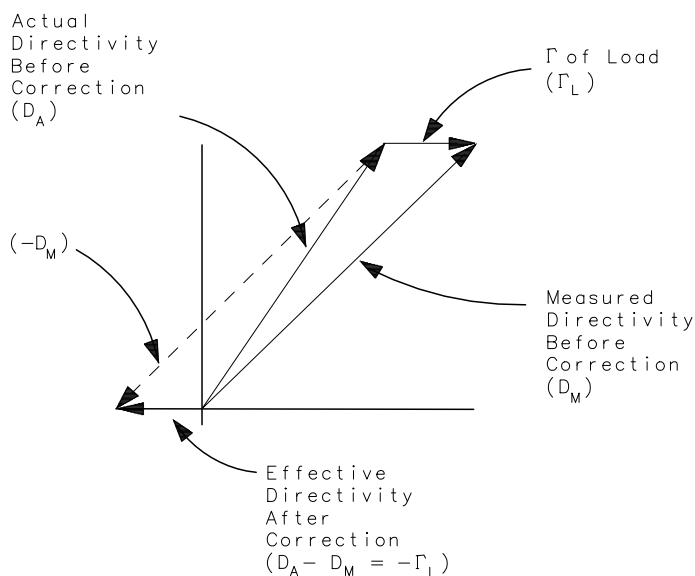

Next, a short circuit termination whose response is known to a very high degree is used to establish another

condition as shown in [Figure 7-31](#).

Figure 7-31 Short Circuit Termination

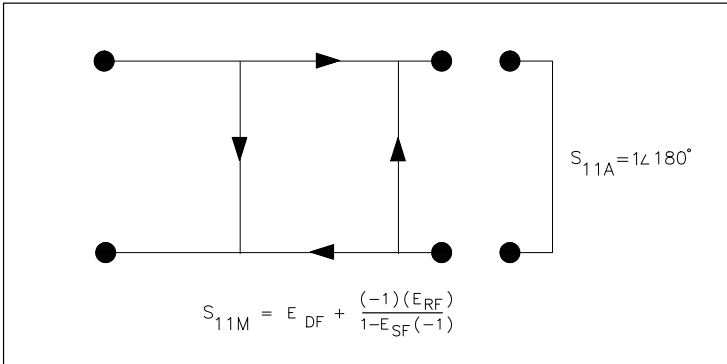

pg656d

The open circuit gives the third independent condition. In order to accurately model the phase variation with frequency due to fringing capacitance from the open connector, a specially designed shielded open circuit is used for this step. (The open circuit capacitance is different with each connector type.) Now the values for E_{DF} , directivity, E_{SF} , source match, and E_{RF} , reflection frequency response, are computed and stored. See [Figure 7-32](#).

Figure 7-32 Open Circuit Termination

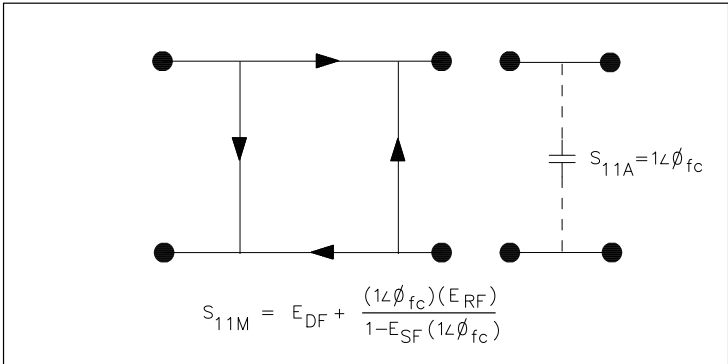

pb6113d

This completes the calibration procedure for one port devices.

Device Measurement

Now the unknown is measured to obtain a value for the measured response, S_{11M} , at each frequency. Refer to [Figure 7-33](#).

Figure 7-33 Measured S_{11}

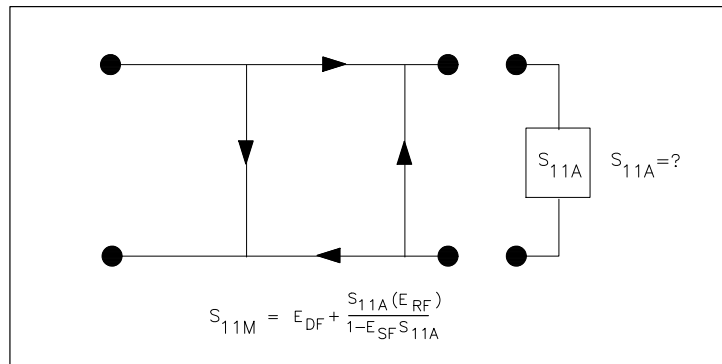

pg658d

This is the one-port error model equation solved for S_{11A} . Since the three errors and S_{11M} are now known for each test frequency, S_{11A} can be computed as follows:

$$S_{11A} = \frac{(S_{11M} - E_{DF})}{E_{SF}(S_{11M} - E_{DF}) + E_{RF}}$$

For reflection measurements on two-port devices, the same technique can be applied, but the test device output port must be terminated in the system characteristic impedance. This termination should have as low a reflection coefficient as the load used to determine directivity. The additional reflection error caused by an improper termination at the test device's output port is not incorporated into the one-port error model.

Two-Port Error Model (ES Models Only)

The error model for measurement of the transmission coefficients (magnitude and phase) of a two-port device is derived in a similar manner. The potential sources of error are frequency response (tracking), source match, load match, and isolation as shown in [Figure 7-34](#). These errors are effectively removed using the full two-port error model.

Figure 7-34 Major Sources of Error

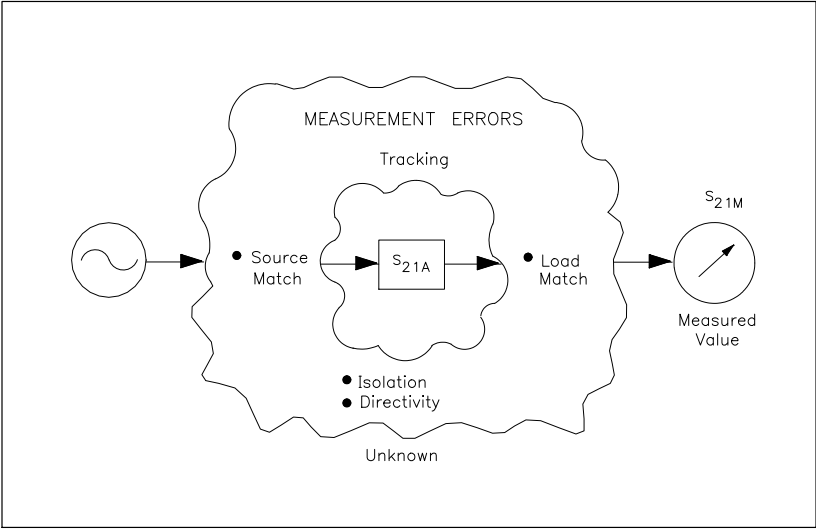

pg659d

The transmission coefficient is measured by taking the ratio of the incident signal (I) and the transmitted signal (T). Refer to [Figure 7-35](#). Ideally, (I) consists only of power delivered by the source, and (T) consists only of power emerging at the test device output.

Figure 7-35 Transmission Coefficient

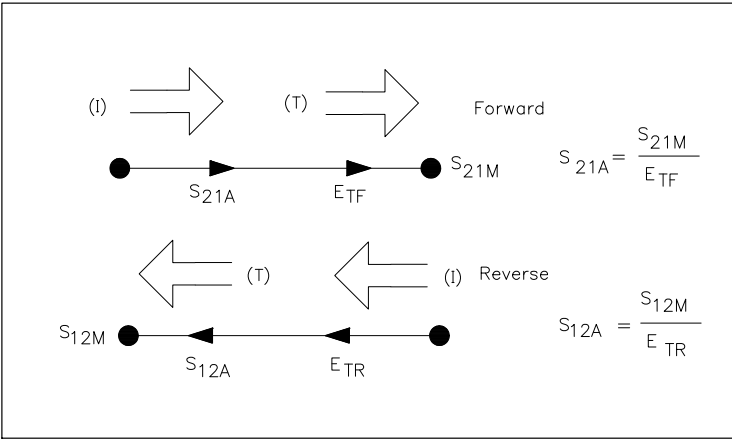

pg660d

As in the reflection model, source match can cause the incident signal to vary as a function of test device S_{11A} . Also, since the test setup transmission return port is never exactly the characteristic impedance, some of the transmitted signal is reflected from the test set port 2, and from other mismatches between the test device output and the receiver input, to return to the test device. A portion of this signal may be re-reflected at port 2, thus affecting S_{21M} , or part may be transmitted through the device in the reverse direction to appear at port 1, thus affecting S_{11M} . This error term, which causes the magnitude and phase of the transmitted signal to vary as a function of S_{22A} , is called load match, E_{LF} . See Figure 7-36.

Figure 7-36 Load Match E_{LF}

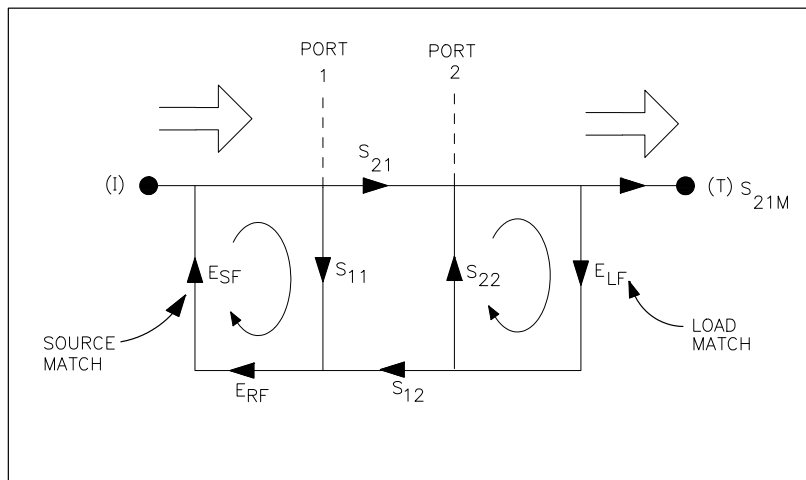

pg661d

The measured value, S_{21M} , consists of signal components that vary as a function of the relationship between E_{SF} and S_{11A} as well as E_{LF} and S_{22A} , so the input and output reflection coefficients of the test device must be measured and stored for use in the S_{21A} error-correction computation. Thus, the test setup is calibrated as described for reflection to establish the directivity, E_{DF} , source match, E_{SF} , and reflection frequency response, E_{RF} , terms for reflection measurements on both ports.

Now that a calibrated port is available for reflection measurements, the thru is connected and load match, E_{LF} , is determined by measuring the reflection coefficient of the thru connection.

Transmission signal path frequency response is then measured with the thru connected. The data is corrected for source and load match effects, then stored as transmission frequency response, E_{TF} .

NOTE It is very important that the exact electrical length of the thru be known. Most calibration kits assume a zero length thru. For some connection types such as Type-N, this implies one male and one female port. If the test system requires a non-zero length thru, for example, one with two male test ports, the exact electrical delay of the thru adapter must be used to modify the built-in calibration kit definition of the thru.

Isolation, E_{XF} , represents the part of the incident signal that appears at the receiver without actually passing through the test device. See Figure 7-37. Isolation is measured with the test set in the transmission configuration and with terminations installed at the points where the test device will be connected. Since isolation can be lower than the noise floor, it is best to increase averaging by at least a factor of four during the isolation portion of the calibration. The **RESUME CAL SEQUENCE** softkey under the **Cal** menu allows a calibration sequence to resume after a change to the averaging factor.

If the leakage falls below the noise floor, it is best to increase averaging before calibration. In this case, omitting isolation is better than measuring the isolation standards without increasing the averaging factor.

Figure 7-37 Isolation E_{XF}

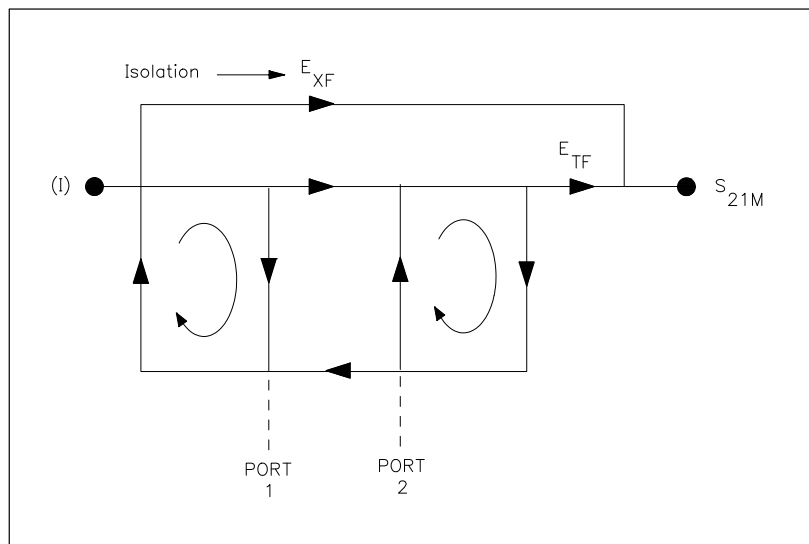

pg662d

Thus there are two sets of error terms, forward and reverse, with each set consisting of six error terms, as follows:

- Directivity, E_{DF} (forward) and E_{DR} (reverse)
- Isolation, E_{XF} and E_{XR}
- Source Match, E_{SF} and E_{SR}
- Load Match, E_{LF} and E_{LR}
- Transmission Tracking, E_{TF} and E_{TR}
- Reflection Tracking, E_{RF} and E_{RR}

The analyzer's test set can measure both the forward and reverse characteristics of the test device without you having to manually remove and physically reverse the device. A full two-port error model illustrated in

Figure 7-38. This illustration depicts how the analyzer effectively removes both the forward and reverse error terms for transmission and reflection measurements.

Figure 7-38 Full Two-Port Error Model

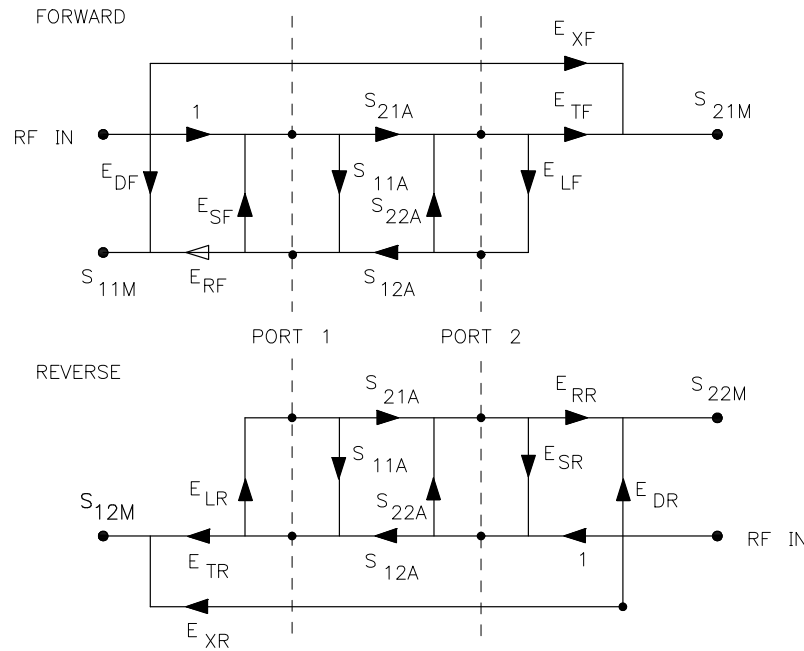

pg663d

A full two-port error model equations for all four S-parameters of a two-port device is shown in Figure 7-39. Note that the mathematics for this comprehensive model use all forward and reverse error terms and measured values. Thus, to perform full error-correction for any one parameter, all four S-parameters must be measured.

Applications of these error models are provided in the calibration procedures described in Chapter 5, "Optimizing Measurement Results."

Enhanced Response Calibration Error Model Enhanced response calibration uses the same error model as the forward configuration portion of Figure 7-38. In the response portion, the source and load match effects are fully-accounted for giving the same accuracy to the forward tracking term (E_{TF}) as the two-port calibration. During the measurement, the enhanced response calibration performs a correction which is mathematically the same as setting the values of E_{LF} , E_{LR} , E_{SR} , E_{XR} , E_{DR} to zero (0) and the values of E_{RR} and E_{TR} to one (1) in the equations for S11 and S21 shown in Figure 7-39.

Figure 7-39 Full Two-Port Error Model Equations

$$S_{11A} = \frac{\left[\left(\frac{S_{11M} - E_{DF}}{E_{RF}} \right) \left[1 + \left(\frac{S_{22M} - E_{DR}}{E_{RR}} \right) E_{SR} \right] \right] - \left[\left(\frac{S_{21M} - E_{XF}}{E_{TF}} \right) \left(\frac{S_{12M} - E_{XR}}{E_{TR}} \right) E_{LF} \right]}{\left[1 + \left(\frac{S_{11M} - E_{DF}}{E_{RF}} \right) E_{SF} \right] \left[1 + \left(\frac{S_{22M} - E_{DR}}{E_{RR}} \right) E_{SR} \right] - \left[\left(\frac{S_{21M} - E_{XF}}{E_{TF}} \right) \left(\frac{S_{12M} - E_{XR}}{E_{TR}} \right) E_{LF} E_{LR} \right]}$$

$$S_{21A} = \frac{\left[1 + \left(\frac{S_{22M} - E_{DR}}{E_{RR}} \right) \left(E_{SR} - E_{LF} \right) \right] \left(\frac{S_{21M} - E_{XF}}{E_{TF}} \right)}{\left[1 + \left(\frac{S_{11M} - E_{DF}}{E_{RF}} \right) E_{SF} \right] \left[1 + \left(\frac{S_{22M} - E_{DR}}{E_{RR}} \right) E_{SR} \right] - \left[\left(\frac{S_{21M} - E_{XF}}{E_{TF}} \right) \left(\frac{S_{12M} - E_{XR}}{E_{TR}} \right) E_{LF} E_{LR} \right]}$$

$$S_{12A} = \frac{\left[1 + \left(\frac{S_{11M} - E_{DF}}{E_{RF}} \right) \left(E_{SF} - E_{LR} \right) \right] \left(\frac{S_{12M} - E_{XR}}{E_{TR}} \right)}{\left[1 + \left(\frac{S_{11M} - E_{DF}}{E_{RF}} \right) E_{SF} \right] \left[1 + \left(\frac{S_{22M} - E_{DR}}{E_{RR}} \right) E_{SR} \right] - \left[\left(\frac{S_{21M} - E_{XF}}{E_{TF}} \right) \left(\frac{S_{12M} - E_{XR}}{E_{TR}} \right) E_{LF} E_{LR} \right]}$$

$$S_{22A} = \frac{\left[\left(\frac{S_{22M} - E_{DR}}{E_{RR}} \right) \left[1 + \left(\frac{S_{11M} - E_{DF}}{E_{RF}} \right) E_{SF} \right] \right] - \left[\left(\frac{S_{21M} - E_{XF}}{E_{TF}} \right) \left(\frac{S_{12M} - E_{XR}}{E_{TR}} \right) E_{LR} \right]}{\left[1 + \left(\frac{S_{11M} - E_{DF}}{E_{RF}} \right) E_{SF} \right] \left[1 + \left(\frac{S_{22M} - E_{DR}}{E_{RR}} \right) E_{SR} \right] - \left[\left(\frac{S_{21M} - E_{XF}}{E_{TF}} \right) \left(\frac{S_{12M} - E_{XR}}{E_{TR}} \right) E_{LF} E_{LR} \right]}$$

pg6128d

How Effective Is Accuracy Enhancement?

In addition to the errors removed by accuracy enhancement, other systematic errors exist due to limitations of dynamic accuracy, test set switch repeatability, and test cable stability. These, combined with random errors, also contribute to total system measurement uncertainty. Therefore, after accuracy enhancement procedures are performed, residual measurement uncertainties remain.

The uncorrected performance of the analyzer is sufficient for many measurements. However, the next three illustrations show the improvements that can be made in measurement accuracy by using a more complete calibration routine. See [Figure 7-40](#), [Figure 7-41](#), and [Figure 7-42](#).

[Figure 7-40a](#) shows a measurement in log magnitude format with a response calibration only. [Figure 7-40b](#)

shows the improvement in the same measurement using an S11 one-port calibration. **Figure 7-41a** shows the measurement on a Smith chart with response calibration only, and **Figure 7-41b** shows the same measurement with an S11 one-port calibration.

Figure 7-40 Response versus S11 1-Port Calibration on Log Magnitude Format

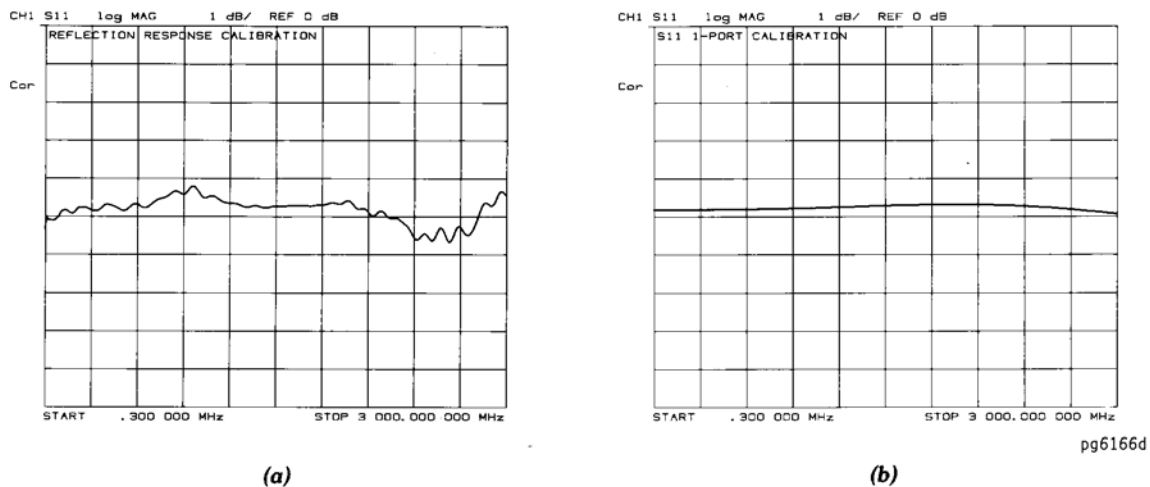
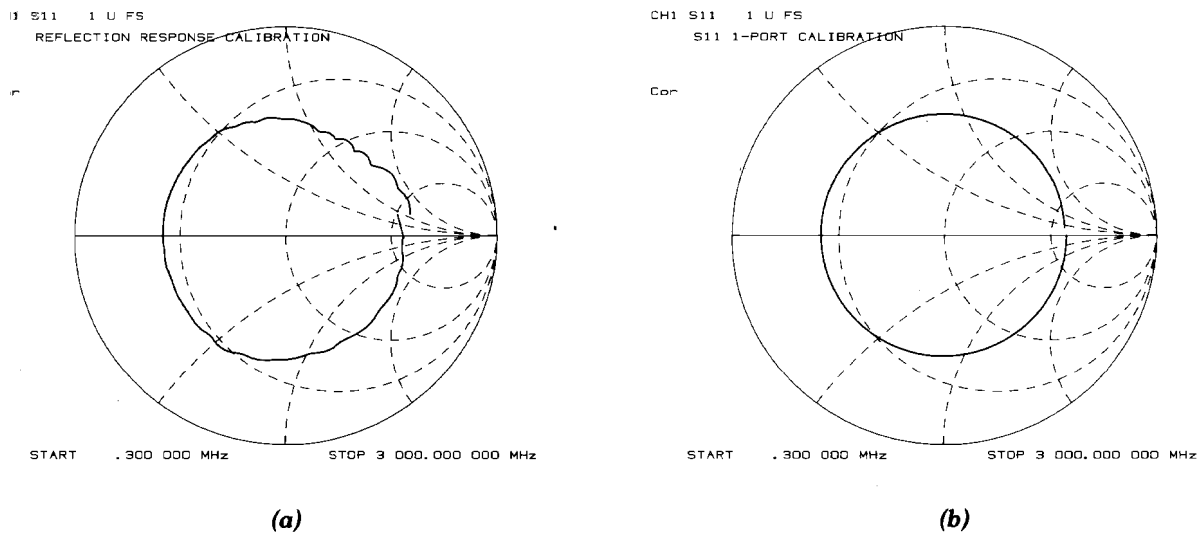
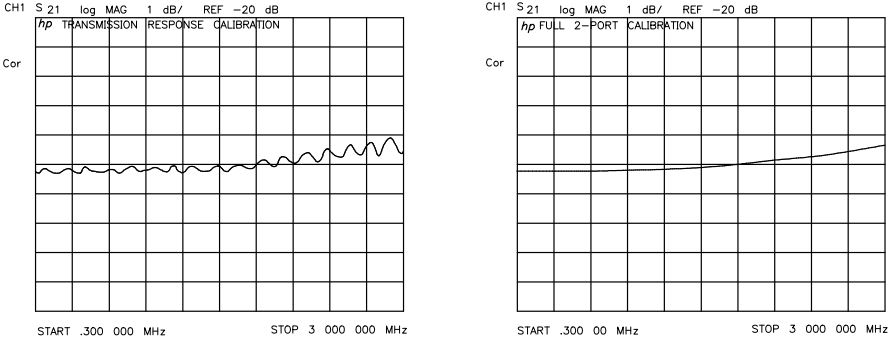

Figure 7-41 Response versus S₁₁ 1-Port Calibration on Smith Chart



The response of a device in a log magnitude format is shown in Figure 7-42. Figure 7-42a shows the response using a response calibration and Figure 7-42b the response using a full two-port calibration.

Figure 7-42 Response versus Full Two-Port Calibration



pg681d

Calibration Routines

There are twelve different error terms for a two-port measurement that can be corrected by accuracy enhancement in the analyzer. These are directivity, source match, load match, isolation, reflection tracking, and transmission tracking, each in both the forward and reverse direction. The analyzer has several different measurement calibration routines to characterize one or more of the systematic error terms and remove their effects from the measured data.

The calibrate menu allows you to perform the measurement calibration routines. These procedures range from a simple frequency response calibration to a full two-port calibration that effectively removes all twelve error terms.

Response Calibration

The response calibration, activated by pressing the **RESPONSE** softkey within the calibrate menu, provides a normalization of the test setup for reflection or transmission measurements. This calibration procedure may be adequate for measurement of well matched devices. This is the simplest error-correction to perform, and should be used when extreme measurement accuracy is not required.

Response and Isolation Calibration

The response and isolation calibration, activated by pressing the **RESPONSE & ISOL'N** softkey within the calibrate menu, provides a normalization for frequency response and crosstalk errors in transmission measurements, or frequency response and directivity errors in reflection measurements. This procedure may be adequate for measurement of well matched high-loss devices.

Enhanced Response Calibration

The enhanced response calibration, activated by pressing the **ENHANCED RESPONSE** softkey within the calibrate menu, provides a one-port calibration to correct for directivity, source match, and frequency response for reflection measurements, and corrects for source match as well as frequency response for transmission measurements.

For ES models, enhanced response calibration improves accuracy in transmission measurements compared to a response calibration or a response and isolation calibration, but it is not as accurate as a full 2-port calibration. For ET models, this calibration provides the best accuracy for measurements with a T/R test set.

Enhanced Reflection Calibration

The enhanced reflection calibration is activated by selecting **ENH. REFL. ON off** under the **ENHANCED RESPONSE** menu.

The enhanced reflection calibration effectively removes load match error from the enhanced response calibration performed on a bilateral device. A bilateral device has an identical forward (S_{21}) and reverse transmission (S_{12}) response. Most passive devices (such as filters, attenuators, or switches) are bilateral. Some passive devices (circulators, isolators) and most active devices do not have identical forward and reverse transmission responses and enhanced reflection calibration will not work with these devices.

S_{11} and S_{22} One-Port Calibration

The S_{11} and S_{22} one-port calibration procedures, activated by pressing the **S11 1-PORT** or **S22 1-PORT** softkey within the calibrate menu, provide directivity, source match, and frequency response vector error-correction for reflection measurements. These procedures provide high accuracy reflection measurements of one-port devices or properly terminated two-port devices.

Full Two-Port Calibration (ES Models Only)

The full two-port calibration, activated by pressing the **FULL 2-PORT** softkey within the calibrate menu, provides directivity, source match, load match, isolation, and frequency response vector error-correction, in both forward and reverse directions, for transmission and reflection measurements of two-port devices. This calibration provides the best magnitude and phase measurement accuracy for both transmission and reflection measurements of two-port devices, and requires an S-parameter test set.

In this type of calibration, both forward and reverse measurements must be made. You have the option of setting the ratio of the number of forward (or reverse) sweeps versus the number of reverse (or forward) sweeps. To access this function, press **Cal** **MORE** **TESTSET SW** and enter the number of sweeps desired.

TRL*/LRM* Two-Port Calibration

The TRL*/LRM* two-port calibration, activated by pressing the **TRL*/LRM* 2-PORT** softkey within the calibration menu, provides the ability to make calibrations using the TRL or LRM method. True TRL/LRM calibration is available on analyzers equipped with Option 400, the Four Sampler Test Set. For more information, refer to [“TRL*/LRM* Calibration \(ES Models Only\)” on page 7-66](#).

E-CAL

The E-Cal calibration menu is activated by pressing **E-CAL MENU** in the calibration menu.

The E-Cal (Electronic Calibration) system determines systemic errors of the analyzer through a one-time connection of an E-Cal module to the network analyzer ports. The random error of connector repeatability is reduced substantially through a one-time connection when compared to frequent connections and disconnections of the conventional short/open/load methods.

Modifying Calibration Kits

Modifying calibration kits is necessary only if unusual standards (such as in TRL*) are used or the very highest accuracy is required. Unless a calibration kit model is provided with the calibration devices used, a solid understanding of error-correction and the system error model are absolutely essential to making modifications. You may use modifications to a predefined calibration kit by modifying the kit and saving it as a user kit. The original predefined calibration kit will remain unchanged.

Before attempting to modify calibration standard definitions, you should read Application Note 8510-5A to improve your understanding of modifying calibration kits. The part number of this application note is 5956-4352. Although the application note is written for the 8510 family of network analyzers, it also applies to this network analyzer.

Several situations exist that may require a user-defined calibration kit:

- A calibration is required for a connector interface different from the four default calibration kits. (Examples: SMA, TNC, or waveguide.)
- A calibration with standards (or combinations of standards) that are different from the default calibration kits is required. (Example: Using three offset shorts instead of open, short, and load to perform a 1-port calibration.)
- The built-in standard models for default calibration kits can be improved or refined. Remember that the more closely the model describes the actual performance of the standard, the better the calibration. (Example: The 7 mm load is determined to be 50.4 Ω instead of 50.0 Ω .)

Definitions

The following are definitions of terms:

- A "standard" (represented by a number 1-8) is a specific, well-defined, physical device used to determine systematic errors. For example, standard 1 is a short in the 3.5 mm calibration kit. Standards are assigned to the instrument softkeys as part of a class.
- A standard "type" is one of five basic types that define the form or structure of the model to be used with that standard (short, open, load, delay/thru, and arbitrary impedance); standard 1 is of the type short in the 3.5 mm calibration kit.
- Standard "coefficients" are numerical characteristics of the standards used in the model selected. For example, the offset delay of the short is 32 ps in the 3.5 mm calibration kit.
- A standard "class" is a grouping of one or more standards that determines which of the eight standards are used at each step of the calibration. For example, standard number 2 and 8 usually makes up the S₁₁A reflection class, which for type-N calibration kits are male and female shorts.

Procedure

The following steps are used to modify or define a user kit:

1. Select the predefined kit to be modified. (This is not necessary for defining a new calibration kit.)
2. Define the standards:
 - Define which "type" of standard it is.
 - Define the electrical characteristics (coefficients) of the standard.
3. Specify the class where the standard is to be assigned.
4. Store the modified calibration kit.

Modify Calibration Kit Menu

The **MODIFY []** softkey in the cal kit menu accesses the modify calibration kit menu. This leads in turn to additional series of menus associated with modifying calibration kits. The following is a description of the softkeys located within this menu:

- **DEFINE STANDARD** makes the standard number the active function, and brings up the define standard menus. Before selecting a standard, a standard number must be entered. This number (1 to 8) is an arbitrary reference number used to reference standards while specifying a class. The standard numbers for the predefined calibration kits are as follows:

- 1 short (m)
- 2 open (m)
- 3 broadband load
- 4 thru
- 5 sliding load
- 6 lowband load
- 7 short (f)
- 8 open (f)

NOTE Although the numbering sequences are arbitrary, confusion can be minimized by using consistency. However, standard 5 is always a sliding load.

- **SPECIFY CLASS** leads to the specify class menu. After the standards are modified, use this key to specify a class to group certain standards.
- **LABEL CLASS** leads to the label class menu, to give the class a meaningful label for future reference.

- **LABEL KIT** leads to a menu for constructing a label for the user-modified cal kit. If a label is supplied, it will appear as one of the five softkey choices in the select cal kit menu. The approach is similar to defining a display title, except that the kit label is limited to ten characters.
- **TRL/LRM OPTION** brings up the TRL Option menu.
- **KIT DONE (MODIFIED)** terminates the calibration kit modification process, after all standards are defined and all classes are specified. Be sure to save the kit with the **SAVE USER KIT** softkey, if it is to be used later.

Define Standard Menus

Standard definition is the process of mathematically modeling the electrical characteristics (delay, attenuation, and impedance) of each calibration standard. These electrical characteristics (coefficients) can be mathematically derived from the physical dimensions and material of each calibration standard, or from its actual measured response. The parameters of the standards can be listed in [Table 7-1](#).

Table 7-1 Standard Definitions

System $Z_0^a =$ _____ Calibration Kit Label _____

Disk File Name: _____

STANDARD ^b		C0 ^c ×10 ⁻¹⁵ F	C1 ^c ×10 ⁻²⁷ F/Hz	C2 ^c ×10 ⁻³⁶ F/Hz ²	C3 ^c ×10 ⁻⁴⁵ F/Hz ³	FIXED ^d SLIDING or OFFSET	TERM ^e IMPED Ω	OFFSET			FREQ (GHz)		COAX or WG	STND LABEL
NO.	TYPE							DELAY s	Z ₀ Ω	LOSS Ω/s	MIN	MAX		
1														
2														
3														
4														
5														
6														
7														
8														

- Ensure system Z_0 of network analyzer is set to this value.
- Open, short, load, delay/thru, or arbitrary impedance.
- Open standard types only.
- Load or arbitrary impedance only.
- Arbitrary impedance only, device terminating impedance.

Each standard must be identified as one of five "types": open, short, load, delay/thru, or arbitrary impedance.

After a standard number is entered, selection of the standard type will present one of five menus for entering the electrical characteristics (model coefficients) corresponding to that standard type, such as **OPEN**. These menus are tailored to the current type, so that only characteristics applicable to the standard type can be modified.

The following is a description of the softkeys located within the define standard menu:

- **OPEN** defines the standard type as an open, used for calibrating reflection measurements. Opens are assigned a terminal impedance of infinite ohms, but delay and loss offsets may still be added. Pressing this key also brings up a menu for defining the open, including its capacitance.

As a reflection standard, an open termination offers the advantage of broadband frequency coverage. At RF and microwave frequencies, however, an open rarely has perfect reflection characteristics because fringing capacitance effects cause phase shift that varies with frequency. This can be observed in measuring an open termination after calibration, when an arc in the lower right circumference of the Smith chart indicates capacitive reactance. These effects are impossible to eliminate, but the calibration kit models include the open termination capacitance at all frequencies for compatible calibration kits. The capacitance model is a cubic polynomial, as a function of frequency, where the polynomial coefficients are user-definable. The capacitance model equation is:

$$C = (C0) + (C1 \times F) + (C2 \times F^2) + (C3 \times F^3)$$

where F is the measurement frequency.

The terms in the equation are defined with the specify open menu as follows:

- **C0** allows you to enter the C0 term, which is the constant term of the cubic polynomial and is scaled by 10^{-15} Farads.
- **C1** allows you to enter the C1 term, expressed in F/Hz (Farads/Hz) and scaled by 10^{-27} .
- **C2** allows you to enter the C2 term, expressed in F/Hz² and scaled by 10^{-36} .
- **C3** allows you to enter the C3 term, expressed in F/Hz³ and scaled by 10^{-45} .
- **SHORT** defines the standard type as a short, for calibrating reflection measurements. Shorts are assigned a terminal impedance of 0 ohms, but delay and loss offsets may still be added.
- **LOAD** defines the standard type as a load (termination). Loads are assigned a terminal impedance equal to the system characteristic impedance Z0, but delay and loss offsets may still be added. If the load impedance is not Z0, use the arbitrary impedance standard definition.
 - **FIXED** defines the load as a fixed (not sliding) load.
 - **SLIDING** defines the load as a sliding load. When such a load is measured during calibration, the analyzer will prompt for several load positions, and calculate the ideal load value from it.
 - **OFFSET** defines the load as being offset.
- **DELAY/THRU** defines the standard type as a transmission line of specified length, for calibrating transmission measurements.
- **ARBITRARY IMPEDANCE** defines the standard type to be a load, but with an arbitrary impedance (different from system Z0).
 - **TERMINAL IMPEDANCE** allows you to specify the (arbitrary) impedance of the standard, in

ohms.

- **FIXED** defines the load as a fixed (not sliding) load.
- **SLIDING** defines the load as a sliding load. When such a load is measured during calibration, the analyzer will prompt for several load positions, and calculate the ideal load value from it. Normally, arbitrary impedance standards are fixed rather than sliding.

Any standard type can be further defined with offsets in delay, loss, and standard impedance; assigned minimum or maximum frequencies over which the standard applies, and defined as coax or waveguide. The **SPECIFY OFFSET** softkey accesses the specify offset menu (described next).

The **LABEL STD** softkey allows you to define a distinct label for each standard, so that the analyzer can prompt you with explicit standard labels during calibration (such as **SHORT**). The function is similar to defining a display title, except that the label is limited to ten characters.

After each standard is defined, including offsets, the **STD DONE (DEFINED)** softkey will terminate the standard definition.

Specify Offset Menu

The specify offset menu allows additional specifications for a user-defined standard. Features specified in this menu are common to all five types of standards.

Offsets may be specified with any standard type. This means defining a uniform length of transmission line to exist between the standard being defined and the actual measurement plane. (Example: a waveguide short circuit terminator, offset by a short length of waveguide.) For reflection standards, the offset is assumed to be between the measurement plane and the terminating element of the standard (one-way only). For transmission standards, the offset is assumed to exist between the two reference planes (in effect, the offset is the thru). For both reflection and transmission, the offset is entered as a one-way offset. Three characteristics of the offset can be defined: its delay (length), loss, and impedance.

In addition, the frequency range over which a particular standard is valid can be defined with a minimum and maximum frequency. This is particularly important for a waveguide standard, since the minimum frequency is used to define the waveguide cutoff frequency. Note that several band-limited standards can together be defined as the same "class" (see "[Specify Class Menu](#)" on page 7-62). Then, if a measurement calibration is performed over a frequency range exceeding a single standard, additional standards can be used for each portion of the range.

Lastly, the standard must be defined as either coaxial or waveguide. If it is waveguide, dispersion effects are calculated automatically and included in the standard model.

The following is a description of the softkeys located within the specify offset menu:

- **OFFSET DELAY** allows you to specify the one-way electrical delay from the measurement (reference) plane to the standard, in seconds (s). (In a transmission standard, offset delay is the delay from plane to plane.) Delay can be calculated from the precise physical length of the offset, the permittivity constant of the medium, and the speed of light.

In coax, group delay is considered constant. In waveguide, however, group delay is dispersive, that is, it changes significantly as a function of frequency. Hence, for a waveguide standard, offset delay must be defined as though it were a TEM wave (without dispersion).

- **OFFSET LOSS** allows you to specify energy loss, due to skin effect, along a one-way length of coax offset. The value of loss is entered as ohms/nanosecond (or Giga ohms/second) at 1 GHz. (Such losses

are negligible in waveguide, so enter 0 as the loss offset.)

- **OFFSET Z0** allows you to specify the characteristic impedance of the coax offset. (Note: This is not the impedance of the standard itself.) For waveguide, the offset impedance as well as the system Z0 must always be set to 1Ω .
- **MINIMUM FREQUENCY** allows you to define the lowest frequency at which the standard can be used during measurement calibration. In waveguide, this must be the lower cutoff frequency of the standard, so that the analyzer can calculate dispersive effects correctly (see **OFFSET DELAY**).
- **MAXIMUM FREQUENCY** allows you to define the highest frequency at which the standard can be used during measurement calibration. In waveguide, this is normally the upper cutoff frequency of the standard.
- **COAX** defines the standard (and the offset) as coaxial. This causes the analyzer to assume linear phase response in any offsets.
- **WAVEGUIDE** defines the standard (and the offset) as rectangular waveguide. This causes the analyzer to assume a dispersive delay (see **OFFSET DELAY**).

Label Standard Menu

This menu allows you to label (reference) individual standards during the menu-driven measurement calibration sequence. The labels are user-definable using a character set shown on the display that includes letters, numbers, and some symbols, and they may be up to ten characters long. The analyzer will prompt you to connect standards using these labels, so they should be meaningful to you, and distinct for each standard.

By convention, when sexed connector standards are labeled male (m) or female (f), the designation refers to the test port connector sex, not the connector sex of the standard.

Specify Class Menu

Once a standard has been defined, it must be assigned to a standard "class." This is a group of from one to seven standards that is required to calibrate for a single error term. The standards within a single class can be assigned to the locations listed in [Table 7-2](#) according to their standard reference numbers.

A class often consists of a single standard, but may be composed of more than one standard if band-limited standards are used. For example, if there were two load standards—a fixed load for low frequencies, and a sliding load for high frequencies—then that class would have two standards.

Table 7-2 Standard Class Assignments

Calibration Kit Label: _____

Disk File Name: _____

Class	Standard Reference Numbers								Standard Class Label
	1	2	3	4	5	6	7	8	
S ₁₁ A									
S ₁₁ B									

Table 7-2 Standard Class Assignments

Calibration Kit Label: _____

Disk File Name: _____

Class	Standard Reference Numbers								Standard Class Label
	1	2	3	4	5	6	7	8	
S ₁₁ C									
S ₂₂ A									
S ₂₂ B									
S ₂₂ C									
Forward Transmission									
Reverse Transmission									
Forward Match									
Reverse Match									
Response									
Response and Isolation									
TRL thru									
TRL reflect									
TRL line or match									

The number of standard classes required depends on the type of calibration being performed, and is identical to the number of error terms corrected. A response calibration requires only one class, and the standards for that class may include an open, or short, or thru. A 1-port calibration requires three classes. A full 2-port calibration requires 10 classes, not including two for isolation.

The number of standards that can be assigned to a given class may vary from none (class not used) to one (simplest class) to seven. When a certain class of standards is required during calibration, the analyzer will display the labels for all the standards in that class (except when the class consists of a single standard). This does not, however, mean that all standards in a class must be measured during calibration. Unless band-limited standards are used, only a single standard per class is required.

NOTE It is often simpler to keep the number of standards per class to the bare minimum needed (often one) to avoid confusion during calibration.

Each class can be given a user-definable label as described under label class menus.

Standards are assigned to a class simply by entering the standard's reference number (established while defining a standard) under a particular class. The following is a description of the softkeys located within the specify class menu:

- **S11A** allows you to enter the standard numbers for the first class required for an S_{11} 1-port calibration. (For default calibration kits, this is the open.)
- **S11B** allows you to enter the standard numbers for the second class required for an S_{11} 1-port calibration. (For default calibration kits, this is the short.)
- **S11C** allows you to enter the standard numbers for the third class required for an S_{11} 1-port calibration. (For default calibration kits, this is the load.)
- **S22A** allows you to enter the standard numbers for the first class required for an S_{22} 1-port calibration. (For default calibration kits, this is the open.)
- **S22B** allows you to enter the standard numbers for the second class required for an S_{22} 1-port calibration. (For default calibration kits, this is the short.)
- **S22C** allows you to enter the standard numbers for the third class required for an S_{22} 1-port calibration. (For default calibration kits, this is the load.)
- **FWD TRANS** allows you to enter the standard numbers for the forward transmission thru calibration. (For default calibration kits, this is the thru.)
- **REV TRANS** allows you to enter the standard numbers for the reverse transmission (thru) calibration. (For default calibration kits, this is the thru.)
- **FWD MATCH** allows you to enter the standard numbers for the forward match (thru) calibration. (For default calibration kits, this is the thru.)
- **REV MATCH** allows you to enter the standard numbers for the reverse match (thru) calibration. (For default calibration kits, this is the thru.)
- **RESPONSE** allows you to enter the standard numbers for a response calibration. This calibration corrects for frequency response in either reflection or transmission measurements, depending on the parameter being measured when a calibration is performed. (For default kits, the standard is either the open or short for reflection measurements, or the thru for transmission measurements.)
- **RESPONSE & ISOL'N** allows you to enter the standard numbers for a response & isolation calibration. This calibration corrects for frequency response and directivity in reflection measurements, or frequency response and isolation in transmission measurements.
- **TRL THRU** allows you to enter the standard numbers for a TRL thru calibration.
- **TRL REFLECT** allows you to enter the standard numbers for a TRL reflect calibration.
- **TRL LINE OR MATCH** allows you to enter the standard numbers for a TRL line or match calibration.

Label Class Menu

The label class menus are used to define meaningful labels for the calibration classes. These then become softkey labels during a measurement calibration. Labels can be up to ten characters long.

Label Kit Menu

This **LABEL KIT** softkey within the modify cal kit menu, accesses this menu. It is identical to the label class menu and the label standard menu previously described. It allows definition of a label up to eight characters long.

After a new calibration kit has been defined, be sure to specify a label for it. Choose a label that describes the connector type of the calibration devices. This label will then appear in the **CAL KIT []** softkey label in the correction menu and the **MODIFY []** label in the select cal kit menu. It will be saved with calibration sets.

Verify Performance

Once a measurement calibration has been generated with a user-defined calibration kit, its performance should be checked before making device measurements. To check the accuracy that can be obtained using the new calibration kit, a device with a well-defined frequency response (preferably unlike any of the standards used) should be measured. The verification device must not be one of the calibration standards: measurement of one of these standards is merely a measure of repeatability.

To achieve more complete verification of a particular measurement calibration, accurately known verification standards with a diverse magnitude and phase response should be used. National standard traceable or Agilent standards are recommended to achieve verifiable measurement accuracy.

NOTE The published specifications for this network analyzer system include accuracy enhancement with compatible calibration kits. Measurement calibrations made with user-defined or modified calibration kits are not subject to the analyzer specifications, although a procedure similar to the system verification procedure may be used.

Saving Modified Calibration Kits to a Disk

The calibration kit, along with any calibration data and other instrument state information, can be saved to an ISTATE file on a floppy disk. To save a modified calibration kit with an instrument state, press:

Cal **CAL KIT** **SELECT CAL KIT** **USER KIT**
Save/Recall **SAVE STATE**

Modifying and Saving a Calibration Kit from the Calibration Kit Selection Menu

To modify a calibration kit from the calibration kit selection menu, press:

Cal **CAL KIT** **SELECT CAL KIT** **MODIFY** **KIT DONE (MODIFIED)**

To save the modified calibration kit, press:

Cal **CAL KIT** **SELECT CAL KIT** **USER KIT** **SAVE USER KIT** or **Save/Recall**
SAVE STATE

Ensure that **USER KIT** is underlined before saving the modified user kit.

TRL*/LRM* Calibration (ES Models Only)

The network analyzer has the capability of making calibrations using the "TRL" (thru-reflect-line) method. This section contains information on the following subjects:

- Why Use TRL Calibration?
- TRL Terminology
- How TRL*/LRM* Calibration Works
- Improving Raw Source Match and Load Match for TRL*/LRM* Calibration
- The TRL Calibration Procedure
 - Requirements for TRL Standards
 - TRL Options

Why Use TRL Calibration?

This method is convenient in that calibration standards can be fabricated for a specific measurement environment, such as a transistor test fixture or microstrip. Microstrip devices in the form of chips, MMIC's, packaged transistors, or beam-lead diodes cannot be connected directly to the coaxial ports of the analyzer. The device under test (DUT) must be physically connected to the network analyzer by some kind of transition network or fixture. Calibration for a fixtured measurement in microstrip presents additional difficulties.

A calibration at the coaxial ports of the network analyzer removes the effects of the network analyzer and any cables or adapters before the fixture; however, the effects of the fixture itself are not accounted for. An in-fixture calibration is preferable, but high-quality short-open-load-thru (SOLT) standards may not be readily available to allow a conventional full 2-port calibration of the system at the desired measurement plane of the device. In microstrip, a short circuit is inductive, an open circuit radiates energy, and a high-quality purely resistive load is difficult to produce over a broad frequency range. The Thru-Reflect-Line (TRL) 2-port calibration is an alternative to the traditional SOLT Full 2-port calibration technique that utilizes simpler, more convenient standards for device measurements in the microstrip environment.

For coaxial, waveguide and other environments where high-quality impedance standards are readily available, the traditional short, open, load, thru (SOLT) method provides the most accurate results since all of the significant systematic errors are reduced. This method is implemented in the form of the S_{11} 1-port, S_{22} 1-port, and full 2-port calibration selections.

In all measurement environments, you must provide calibration standards for the desired calibration to be performed. The advantage of TRL is that only three standards need to be characterized as opposed to 4 in the traditional open, short, load, and thru full 2-port calibrations. Further, the requirements for characterizing the T, R, and L standards are less stringent and these standards are more easily fabricated.

TRL Terminology

Notice that the letters TRL, LRL, LRM, etc. are often interchanged, depending on the standards used. For example, "LRL" indicates that two lines and a reflect standard are used; "TRM" indicates that a thru, reflection and match standards are used. All of these refer to the same basic method.

TRL* calibration is a modified form of TRL calibration. It is adapted for a receiver with three samplers instead of four samplers. The TRL* calibration is not as accurate as the TRL calibration because it cannot isolate the source match from the load match, so it assumes load match and source match are equal. However, option 400 on the ES model adds the fourth sampler and provides for a true TRL calibration.

How TRL*/LRM* Calibration Works

The TRL*/LRM* calibration used in the analyzer relies on the characteristic impedance of simple transmission lines rather than on a set of discrete impedance standards. Since transmission lines are relatively easy to fabricate (in a microstrip, for example), the impedance of these lines can be determined from the physical dimensions and substrate's dielectric constant.

TRL* Error Model

Figure 7-43 Functional Block Diagram for a 2-Port Error-Corrected Measurement System

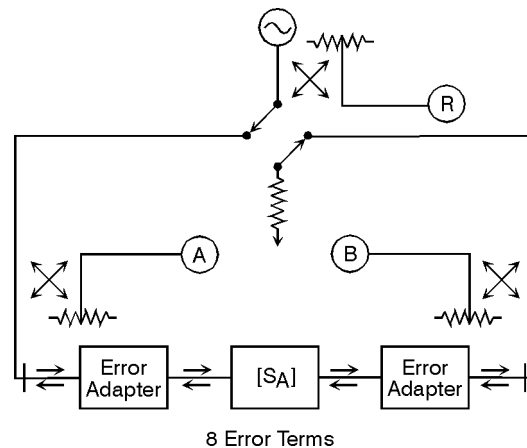

pb6120d

For the analyzer TRL* 2-port calibration, a total of 10 measurements are made to quantify eight unknowns (not including the two isolation error terms). Assume the two transmission leakage terms, E_{XF} and E_{XR} , are measured using the conventional technique. The eight TRL error terms are represented by the error adapters shown in Figure 7-43. Although this error model is slightly different from the traditional Full 2-port 12-term model, the conventional error terms may be derived from it. For example, the forward reflection tracking (E_{RF}) is represented by the product of ϵ_{10} and ϵ_{01} .

Also notice that the forward source match (E_{SF}) and reverse load match (E_{LR}) are both represented by ϵ_{11} , while the reverse source match (E_{SR}) and forward load match (E_{LF}) are both represented by ϵ_{22} . In order to solve for these eight unknown TRL error terms, eight linearly independent equations are required.

The first step in the TRL* 2-port calibration process is the same as the transmission step for a Full 2-port calibration. For the thru step, the test ports are connected together directly (zero length thru) or with a short length of transmission line (non-zero length thru) and the transmission frequency response and port match are measured in both directions by measuring all four S-parameters.

For the reflect step, identical high reflection coefficient standards (typically open or short circuits) are connected to each test port and measured (S_{11} and S_{22}).

For the line step, a short length of transmission line (different in length from the thru) is inserted between port 1 and port 2 and again the frequency response and port match are measured in both directions by measuring all four S-parameters.

In total, ten measurements are made, resulting in ten independent equations. However, the TRL error model has only eight error terms to solve for. The characteristic impedance of the line standard becomes the measurement reference and, therefore, has to be assumed ideal (or known and defined precisely).

At this point, the forward and reverse directivity (E_{DF} and E_{DR}), transmission tracking (E_{TF} and E_{TR}), and reflection tracking (E_{RF} and E_{RR}) terms may be derived from the TRL error terms. This leaves the isolation (E_{XF} and E_{XR}), source match (E_{SF} and E_{SR}) and load match (E_{LF} and E_{LR}) terms to discuss.

Isolation

Two additional measurements are required to solve for the isolation terms (E_{XF} and E_{XR}). Isolation is characterized in the same manner as the Full 2-port calibration. Forward and reverse isolation are measured as the leakage (or crosstalk) from port 1 to port 2 with each port terminated. The isolation part of the calibration is generally only necessary when measuring high loss devices (greater than 70 dB).

NOTE **If an isolation calibration is performed, the fixture leakage must be the same during the isolation calibration and the measurement.**

Figure 7-44 **8-term TRL (or TRL*) Error Model and Generalized Coefficients**

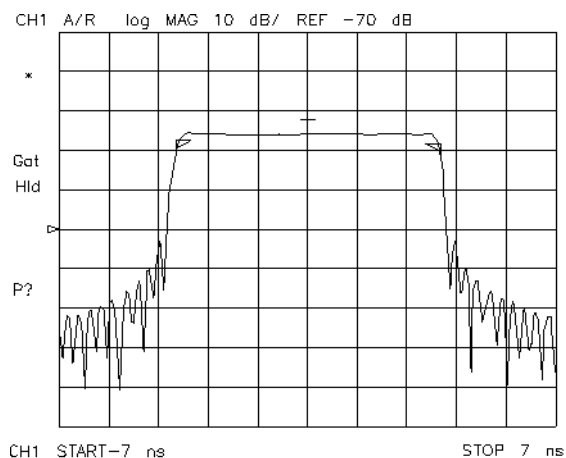

pg6121d

Source match and load match

A TRL calibration assumes a perfectly balanced test set architecture as shown by the term which represents both the forward source match (E_{SF}) and reverse load match (E_{LR}), and by the ϵ_{22} term which represents both the reverse source match (E_{SR}) and forward load match (E_{LF}). However, in any switching test set, the source and load match terms are not equal because the transfer switch presents a different terminating impedance as it is changed between port 1 and port 2.

Because the standard network analyzer is based on a three-sampler receiver architecture, it is not possible to differentiate the source match from the load match terms. The terminating impedance of the switch is assumed to be the same in either direction. Therefore, the test port mismatch cannot be fully corrected. An assumption is made that:

$$\text{forward source match } (E_{SF}) = \text{reverse load match } (E_{LR}) = \varepsilon_{11}$$

$$\text{reverse source match } (E_{SR}) = \text{forward load match } (E_{LF}) = \varepsilon_{22}$$

For a fixture, TRL* can eliminate the effects of the fixture's loss and length, but does not completely remove the effects due to the mismatch of the fixture.

NOTE Because the TRL technique relies on the characteristic impedance of transmission lines, the mathematically equivalent method LRM (for line-reflect-match) may be substituted for TRL. Since a well matched termination is, in essence, an infinitely long transmission line, it is well suited for low (RF) frequency calibrations. Achieving a long line standard for low frequencies is often times physically impossible.

Improving Raw Source Match and Load Match for TRL*/LRM* Calibration

A technique that can be used to improve the raw test port mismatch is to add high quality fixed attenuators. The effective match of the system is improved because the fixed attenuators usually have a return loss that is better than that of the network analyzer. Additionally, the attenuators provide some isolation of reflected signals. The attenuators also help to minimize the difference between the port source match and load match, making the error terms more equivalent.

With the attenuators in place, the effective port match of the system is improved so that the mismatch of the fixture transition itself dominates the measurement errors after a calibration.

Figure 7-45 Typical Measurement Set up

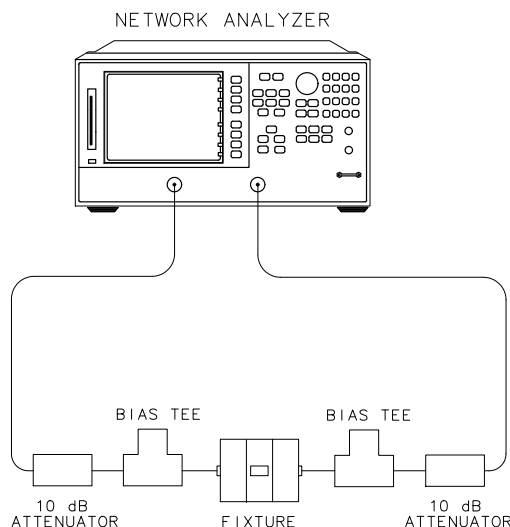

pg640e

If the device measurement requires bias, it will be necessary to add external bias tees between the fixed

attenuators and the fixture. The internal bias tees of the analyzer will not pass the bias properly through the external fixed attenuators. Be sure to calibrate with the external bias tees in place (no bias applied during calibration) to remove their effect from the measurement.

Because the bias tees must be placed after the attenuators, they essentially become part of the fixture. Their mismatch effects are the same for source match and load match, so the TRL CAL routine will correct for their effects. Although the fixed attenuators improve the raw mismatch of the network analyzer system, they also degrade the overall measurement dynamic range.

This effective mismatch of the system after calibration has the biggest effect on reflection measurements of highly reflective devices. Likewise, for well matched devices, the effects of mismatch are negligible. This can be shown by the following approximation:

$$\text{Reflection magnitude uncertainty} = E_D + E_R S_{11} + E_S (S_{11})^2 + E_L S_{21} S_{12}$$

$$\text{Transmission magnitude uncertainty} = E_X + E_T S_{21} + E_S S_{11} S_{21} + E_L S_{22} S_{21}$$

where:

E_D = effective directivity

E_R = effective reflection tracking

E_S = effective source match

E_L = effective load match

E_X = effective crosstalk

E_T = effective transmission tracking

S_{xx} = S-parameters of the device under test

How True TRL/LRM Works (Option 400 Only)

The TRL implementation with Option 400 requires a total of fourteen measurements to quantify ten unknowns as opposed to only a total of twelve measurements for TRL*. (Both include the two isolation error terms.)

Because of the four-sampler receiver architecture of Option 400, additional correction of the source match and load match terms is achieved by measuring the ratio of the two "reference" receivers during the thru and line steps. These measurements characterize the impedance of the switch and associated hardware in both the forward and reverse measurement configurations. They are then used to modify the corresponding source and load match terms (for both forward and reverse).

The Option 400 configuration with TRL established a higher performance calibration method over TRL* when making in-fixture measurements, because all significant error terms are systematically reduced. With TRL*, the source and load match terms are essentially that of the raw, "uncorrected" performance of the hardware.

The TRL Calibration Procedure

Requirements for TRL Standards

When building a set of TRL standards for a microstrip or fixture environment, the requirements for each of

these standard types must be satisfied.

Types	Requirements
<p>THRU (Zero length)</p>	<ul style="list-style-type: none"> • No loss. Characteristic impedance (Z_0) need not be known. • $S_{21} = S_{12} = 1 \angle 0^\circ$ • $S_{11} = S_{22} = 0$
<p>THRU (Non-zero length)</p>	<ul style="list-style-type: none"> • Z_0 of the thru must be the same as the line. (If they are not the same, the average impedance is used.) • Attenuation of the thru need not be known. • If the thru is used to set the reference plane, the insertion phase or electrical length must be well-known and specified. If a non-zero length thru is specified to have zero delay, the reference plane is established in the middle of the thru, resulting in phase errors during measurement of devices.
<p>REFLECT</p>	<ul style="list-style-type: none"> • Reflection coefficient Γ magnitude is optimally 1.0, but need not be known. • Phase of Γ must known and specified to within $\pm 1/4$ wavelength or $\pm 90^\circ$. During computation of the error model, the root choice in the solution of a quadratic equation is based on the reflection data. An error in definition would show up as a 180° error in the measured phase. • Γ must be identical on both ports. • If the reflect is used to set the reference plane, the phase response must be well-known and specified.
<p>LINE/MATCH (LINE)</p>	<ul style="list-style-type: none"> • Z_0 of the line establishes the reference impedance of the measurement (i.e. $S_{11} = S_{22} = 0$). The calibration impedance is defined to be the same as Z_0 of the line. If the Z_0 is known but not the desired value (i.e., not equal to 50Ω), the SYSTEMS Z_0 selection under the TRL/LRM options menu is used. • Insertion phase of the line must not be the same as the thru (zero length or non-zero length). The difference between the thru and line must be between $(20^\circ \text{ and } 160^\circ) \pm n \times 180^\circ$. Measurement uncertainty will increase significantly when the insertion phase nears 0 or an integer multiple of 180°. • Optimal line length is $1/4$ wavelength or 90° of insertion phase relative to the thru at the middle of the desired frequency span. • Usable bandwidth for a single thru/line pair is 8:1 (frequency span:start frequency). • Multiple thru/line pairs (Z_0 assumed identical) can be used to extend the bandwidth to the extent transmission lines are available. • Attenuation of the line need not be known. • Insertion phase must be known and specified within $\pm 1/4$ wavelength or $\pm 90^\circ$.

LINE/MATCH
(MATCH)

- Z_0 of the match establishes the reference impedance of the measurement.
- Γ must be identical on both ports.

Fabricating and defining calibration standards for TRL/LRM

When calibrating a network analyzer, the actual calibration standards must have known physical characteristics. For the reflect standard, these characteristics include the offset in electrical delay (seconds) and the loss (ohms/second of delay). The characteristic impedance, **OFFSET Z0**, is not used in the calculations in that it is determined by the line standard. The reflection coefficient magnitude should optimally be 1.0, but need not be known since the same reflection coefficient magnitude must be applied to both ports.

The thru standard may be a zero-length or known length of transmission line. The value of length must be converted to electrical delay, just like that done for the reflect standard. The loss term must also be specified.

The line standard must meet specific frequency related criteria, in conjunction with the length used by the thru standard. In particular, the insertion phase of the line must not be the same as the thru. The optimal line length is 1/4 wavelength (90 degrees) relative to a zero length thru at the center frequency of interest, and between 20 and 160 degrees of phase difference over the frequency range of interest. (Note: these phase values can be $\pm N \times 180$ degrees where N is an integer.) If two lines are used (LRL), the difference in electrical length of the two lines should meet these optimal conditions. Measurement uncertainty will increase significantly when the insertion phase nears zero or is an integer multiple of 180 degrees, and this condition is not recommended.

For a transmission media that exhibits linear phase over the frequency range of interest, the following expression can be used to determine a suitable line length of one-quarter wavelength at the center frequency (which equals the sum of the start frequency and stop frequency divided by 2):

$$\text{Electrical length (cm)} = (\text{LINE} - \text{0 length THRU})$$

$$\text{Electrical length (cm)} = \frac{(15000 \times VF)}{f1(\text{MHz}) + f2(\text{MHz})}$$

let:

$$f1 = 1000 \text{ MHz}$$

$$f2 = 2000 \text{ MHz}$$

$$VF = \text{Velocity Factor} = 1 \text{ (for this example)}$$

Thus, the length to initially check is 5 cm.

Next, use the following to verify the insertion phase at f1 and f2:

$$Phase \text{ (degrees)} = \frac{(360 \times f \times l)}{v}$$

where:

f = frequency

l = length of line

v = velocity = speed of light × velocity factor

which can be reduced to the following using frequencies in MHz and length in centimeters:

$$Phase \text{ (degrees) approx} = \frac{0.012 \times f(\text{MHz}) \times l(\text{cm})}{VF}$$

So for an air line (velocity factor approximately 1) at 1000 MHz, the insertion phase is 60 degrees for a 5 cm line; it is 120 degrees at 2000 MHz. This line would be a suitable line standard.

For microstrip and other fabricated standards, the velocity factor is significant. In those cases, the phase calculation must be divided by that factor. For example, if the dielectric constant for a substrate is 10, and the corresponding "effective" dielectric constant for microstrip is 6.5, then the "effective" velocity factor equals 0.39 (1 ÷ square root of 6.5).

Using the first equation with a velocity factor of 0.39, the initial length to test would be 1.95 cm. This length provides an insertion phase at 1000 MHz of 60 degrees; at 2000 MHz, 120 degrees (the insertion phase should be the same as the air line because the velocity factor was accounted for when using the first equation).

Another reason for showing this example is to point out the potential problem in calibrating at low frequencies using TRL. For example, one-quarter wavelength is

$$Length \text{ (cm)} = \frac{7500 \times VF}{fc}$$

where:

- fc = center frequency

Thus, at 50 MHz,

$$Length \text{ (cm)} = \frac{7500}{50(\text{MHz})} = 150 \text{ cm or } 1.5 \text{ m}$$

Such a line standard would not only be difficult to fabricate, but its long term stability and usability would be questionable as well.

Thus at lower frequencies or very broad band measurements, fabrication of a "match" or termination may be

deemed more practical. Since a termination is, in essence, an infinitely long transmission line, it fits the TRL model mathematically, and is sometimes referred to as a "TRM" calibration.

The TRM calibration technique is related to TRL with the difference being that it bases the characteristic impedance of the measurement on a matched Z_0 termination instead of a transmission line for the third measurement standard. Like the TRL thru standard, the TRM THRU standard can either be of zero length or non-zero length. The same rules for thru and reflect standards used for TRL apply for TRM.

TRM has no inherent frequency coverage limitations which makes it more convenient in some measurement situations. Additionally, because TRL requires a different physical length for the thru and the line standards, its use becomes impractical for fixtures with contacts that are at a fixed physical distance from each other.

For information on how to modify calibration constants for TRL*/LRM*, and how to perform a TRL or TRM calibration, refer to "Calibrating for Non-Coaxial Devices (ES Analyzers Only)" on page 6-50.

TRL Options

The **TRL/LRM OPTION** softkey accesses the TRL/LRM options menu. There are two selections under this menu:

- **CAL Z0:** (calibration Z_0)
- **SET REF:** (set reference)

The characteristic impedance used during the calibration can be referenced to either the line (or match) standard (**CAL Z0: LINE Z0**) or to the system (**CAL Z0: SYSTEM Z0**). The analyzer defaults to a calibration impedance that is equal to the line (or match) standard.

When the **CAL Z0: LINE Z0** is selected, the impedance of the line (or match) standard is assumed to match the system impedance exactly (the line standard is reflectionless). After a calibration, all measurements are referenced to the impedance of the line standard. For example, when the line standard is remeasured, the response will appear at the center of the Smith chart. When **CAL Z0: LINE Z0** is selected, the values entered for **SET Z0** (under **Cal** menu) and **OFFSET Z0** (within the define standard menu) are ignored.

CAL Z0: SYSTEM Z0 is selected when the desired measurement impedance differs from the impedance of the line standard. This requires a knowledge of the exact value of the Z_0 of the line. The system reference impedance is set using **SET Z0** under the calibration menu. The actual impedance of the line is set by entering the real part of the line impedance as the **OFFSET Z0** within the define standard menu. For example, if the line was known to have a characteristic impedance of 51 Ω (**OFFSET Z0** = 51 Ω), it could still be used to calibrate for a 50 Ω measurement (**SET Z0** = 50 Ω). After a calibration, all measurements would be referenced to 50 Ω , instead of 51 Ω . When the line standard is remeasured, the center of the Smith chart is at the current value of **SET Z0** (in this case, 50 Ω). Since only one value of offset Z_0 can be selected for the line standard, the value of Z_0 should be a constant value over the frequency range of interest in order to be meaningful.

The location of the reference plane is determined by the selection of **SET REF: THRU** and **SET REF: REFLECT**. By default, the reference plane is set with the thru standard which must have a known insertion phase or electrical length. If a non-zero length thru is specified to have zero delay, the reference plane will be established in the middle of the thru. The reflect standard may be used to set the reference plane instead of the thru provided the phase response (offset delay, reactance values and standard type) of the reflect standard is known and is specified in the calibration kit definition.

NOTE **Dispersion Effects**

Dispersion occurs when a transmission medium exhibits a variable propagation or phase velocity as a function of frequency. The result of dispersion is a non-linear phase shift versus frequency, which leads to a group delay which is not constant. Fortunately, the TRL calibration technique accounts for dispersive effects of the test fixture up to the calibration plane, provided that:

1. The thru (zero or non-zero length) is defined as having zero electrical length and is used to set the reference plane (**SET REF: THRU**).
2. The transmission lines used as calibration standards have identical dispersion characteristics (i.e., identical height, width and relative dielectric constant).

When a non-zero length thru is used to set the reference plane, it should be defined as having zero length in the TRL standards definition, even though it has physical length. The actual electrical length of the thru standard must then be subtracted from the actual electrical length of each line standard in the TRL calibration kit definition. The device must then be mounted between two short lengths of transmission line so that each length is exactly one-half of the length of the non-zero length thru standard. In this configuration, the measurement will be properly calibrated up to the point of the device.

GPIB Operation

This section contains information on the following topics:

- local key
- GPIB controller modes
- instrument addresses
- using the parallel port

Local Key

This key allows you to return the analyzer to local (front panel) operation from remote (computer controlled) operation. This key will also abort a test sequence or hardcopy print/plot. In this local mode, with a controller still connected on GPIB, you can operate the analyzer manually (locally) from the front panel. This is the only front panel key that is not disabled when the analyzer is remotely controlled over GPIB by a computer. The exception to this is when local lockout is in effect: this is a remote command that disables the **Local** key, making it difficult to interfere with the analyzer while it is under computer control.

In addition, the **Local** key accesses the GPIB menu, where you can set the controller mode, and to the address menu, where you can enter the GPIB addresses of peripheral devices and select plotter/printer ports. You can also set the mode of the parallel port here.

The GPIB menu consists of the following softkeys:

- **SYSTEM CONTROLLER**
- **TALKER/LISTENER**
- **USE PASS CONTROL**
- **SET ADDRESS**
- **PARALLEL []**
- **GPIB DIAG on OFF**
- **DISK UNIT NUMBER**
- **VOLUME NUMBER**

The analyzer is factory-equipped with a remote programming interface using the General Purpose Interface Bus (GPIB). This enables communication between the analyzer and a controlling computer as well as other peripheral devices. This menu indicates the present GPIB controller mode of the analyzer. Three GPIB modes are possible: system controller, talker/listener, and pass control.

GPIB STATUS Indicators

When the analyzer is connected to other instruments over GPIB, the GPIB STATUS indicators in the instrument state function block light up to display the current status of the analyzer.

R = remote operation

L = listen mode

T = talk mode

S = service request (SRQ) asserted by the analyzer

System Controller Mode

The **SYSTEM CONTROLLER** softkey activates the system controller mode. When in this mode, the analyzer can use GPIB to control compatible peripherals, without the use of an external computer. It can output measurement results directly to a compatible printer or plotter, store instrument states using a compatible disk drive, or control a power meter for performing service routines. The power meter calibration function requires system controller or pass control mode.

Talker/Listener Mode

The **TALKER/LISTENER** softkey activates the talker/listener mode, which is the mode of operation most often used. In this mode, a computer controller communicates with the analyzer and other compatible peripherals over the bus. The computer sends commands or instructions to and receives data from the analyzer. All of the capabilities available from the analyzer front panel can be used in this remote operation mode, except for control of the power line switch and some internal tests.

Pass Control Mode

The **USE PASS CONTROL** softkey activates the third mode of GPIB operation: the pass control mode. In an automated system with a computer controller, the controller can pass control of the bus to the analyzer on request from the analyzer. The analyzer is then the controller of the peripherals, and can direct them to plot, print, or store without going through the computer. When the peripheral operation is complete, control is passed back to the computer. Only one controller can be active at a time. The computer remains the system controller, and can regain control at any time.

Preset does not affect the selected controller mode, but cycling the power returns the analyzer to talker/listener mode.

Information on compatible peripherals is provided in the “Options and Accessories” chapter of the reference guide.

Address Menu

This menu can be accessed by pressing the **SET ADDRESS** softkey within the GPIB menu.

In communications through the General Purpose Interface Bus (GPIB), each instrument on the bus is identified by a GPIB address. This decimal-based address code must be different for each instrument on the bus.

This menu lets you set the GPIB address of the analyzer, and enter the addresses of peripheral devices so that the analyzer can communicate with them.

Most of the GPIB addresses are set at the factory and need not be modified for normal system operation. The standard factory-set addresses for instruments that may be part of the system are as follows:

Instrument	GPIB Address (decimal)
Analyzer	16
Plotter	05
Printer	01
External Disk Drive	00
Controller	21
Power Meter	13

The address displayed in this menu for each peripheral device must match the address set on the device itself. The analyzer does not have a GPIB switch: its address is set only from the front panel.

These addresses are stored in non-volatile memory and are not affected by preset or by cycling the power.

Using the Parallel Port

The instrument's parallel port can be used in two different modes. By pressing **Local** and then toggling the **PARALLEL []** softkey, you can select either the **[COPY]** mode or the **[GPIO]** mode.

The Copy Mode

The copy mode allows the parallel port to be connected to a printer or plotter for the outputting of test results. To use the parallel port for printing or plotting, you must do the following:

1. Press **Local** **SET ADDRESSES**.
2. Select either **PLOTTER PORT** or **PRINTER PORT**.
3. Select **PARALLEL** so that copy is underlined.

The GPIO Mode

The GPIO mode turns the parallel port into a "general purpose input/output" port.

In this mode the port can be connected to test fixtures, power supplies, and other peripheral equipment that might be used to interact with the analyzer during measurements. This mode is exclusively used in test

sequencing.

Limit Line Operation

This menu can be accessed by pressing **LIMIT MENU** **LIMIT LINE** within the system menu.

You can have limit lines drawn on the display to represent upper and lower limits or device specifications with which to compare the test device. Limits are defined in segments, where each segment is a portion of the stimulus span. Each limit segment has an upper and a lower starting limit value. Three types of segments are available: flat line, sloping line, and single point.

Limits can be defined independently for the four channels, up to 22 segments for each channel. These can be in any combination of the three limit types.

Limit testing compares the measured data with the defined limits, and provides pass or fail information for each measured data point. An out-of-limit test condition is indicated in five ways: with a FAIL message on the screen, with a beep, by changing the color of the failing portions of a trace, with an asterisk in tabular listings of data, and with a bit in the GPIB event status register B. (The analyzer also has a BNC rear panel output that includes this status, but is only valid for a single channel measurement.)

NOTE The limit test output has three selectable modes. For more information, refer to [“Using Limit Lines to Test a Device” on page 1-72](#).

Limit lines and limit testing can be used simultaneously or independently. If limit lines are on and limit testing is off, the limit lines are shown on the display for visual comparison and adjustment of the measurement trace. However, no pass/fail information is provided. If limit testing is on and limit lines are off, the specified limits are still valid and the pass/fail status is indicated even though the limit lines are not shown on the display.

Limits are entered in tabular form. Limit lines and limit testing can be either on or off while limits are defined. As new limits are entered, the tabular columns on the display are updated, and the limit lines (if on) are modified to the new definitions. The complete limit set can be offset in either stimulus or amplitude value.

Limits are checked only at the actual measured data points. It is possible for a device to be out of specification without a limit test failure indication if the point density is insufficient. Be sure to specify a high enough number of measurement points in the stimulus menu.

Limit lines are displayed only on Cartesian formats. In polar and Smith chart formats, limit testing of one value is available: the value tested depends on the marker mode and is the magnitude or the first value in a complex pair. The message NO LIMIT LINES DISPLAYED is shown on the display in polar and Smith chart formats.

The list values feature in the copy menu provides tabular listings to the display or a printer for every measured stimulus value. These include limit line or limit test information if these functions are activated. If limit testing is on, an asterisk is listed next to any measured value that is out of limits. If limit lines are on, and other listed data allows sufficient space, the upper limit and lower limit are listed, together with the margin by which the device data passes or fails the nearest limit.

If limit lines are on, they are plotted with the data on a plot. If limit testing is on, the PASS or FAIL message is plotted, and the failing portions of the trace that are a different color on the display are also a different color on the plot. If limits are specified, they are saved in memory with an instrument state.

Edit Limits Menu

This menu allows you to specify limits for limit lines or limit testing, and presents a table of limit values on the display. Limits are defined in segments. Each segment is a portion of the stimulus span. Up to 22 limit segments can be specified for each channel. The limit segments do not have to be entered in any particular order: the analyzer automatically sorts them and lists them on the display in increasing order of start stimulus value.

For each segment, the table lists the segment number, the starting stimulus value, upper limit, lower limit, and limit type. The ending stimulus value is the start value of the next segment, or a segment can be terminated with a single point segment. You can enter limit values as upper and lower limits or delta limits and middle value. As new limit segments are defined, the tabular listing is updated. If limit lines are switched on, they are shown on the display.

If no limits have been defined, the table of limit values shows the notation `EMPTY`. Limit segments are added to the table using the **ADD** softkey or edited with the **EDIT** softkey, as previously described. The last segment on the list is followed by the notation `END`.

Edit Segment Menu

This menu sets the values of the individual limit segments. The segment to be modified, or a default segment, is selected in the edit limits menu. The stimulus value can be set with the controls in the entry block or with a marker (the marker is activated automatically when this menu is presented). The limit values can be defined as upper and lower limits, or delta limits and middle value. Both an upper limit and a lower limit (or delta limits) must be defined: if only one limit is required for a particular measurement, force the other out of range (for example $+500$ dB or -500 dB).

As new values are entered, the tabular listing of limit values is updated.

Segments do not have to be listed in any particular order: the analyzer sorts them automatically in increasing order of start stimulus value when the **DONE** key in the edit limits menu is pressed. However, the easiest way to enter a set of limits is to start with the lowest stimulus value and define the segments from left to right of the display, with limit lines turned on as a visual check.

Phase limit values can be specified between $+500^\circ$ and -500° . Limit values above $+180^\circ$ and below -180° are mapped into the range of -180° to $+180^\circ$ to correspond with the range of phase data values.

Offset Limits Menu

This menu allows the complete limit set to be offset in either stimulus value or amplitude value. This is useful for changing the limits to correspond with a change in the test setup, or for device specifications that differ in stimulus or amplitude. It can also be used to move the limit lines away from the data trace temporarily for visual examination of trace detail.

Knowing the Instrument Modes

There are three major instrument modes of the analyzer:

- network analyzer mode
- tuned receiver mode
- frequency offset operation (Option 089)

Network Analyzer Mode

This is the standard mode of operation for the analyzer, and is active after you press **Preset** or switch on the AC power. This mode uses the analyzer's internal source.

Pressing **System** **INSTRUMENT MODE** **NETWORK ANALYZER** returns the analyzer to the "normal" network analyzer operating mode.

Tuned Receiver Mode

In the tuned receiver mode, the analyzer's receiver operates independently of any signal source. This mode is not phase-locked and functions in all sweep types. The analyzer tunes the receiver to a synthesized CW input signal at a precisely specified frequency. All phase lock routines are bypassed, increasing sweep speed significantly. The external source must be synthesized, and must drive the analyzer's external frequency reference. The analyzer's internal source frequency is not accurate, and the internal source should not be used in the tuned receiver mode.

Using the analyzer's tuned receiver mode is useful for automated test applications where an external synthesized source is available and applications where speed is important. Although the tuned receiver mode can function in all sweep types, it is typically used in CW applications.

Typical test setup

1. Activate the tuned receiver mode by pressing **System** **INSTRUMENT MODE** **TUNED RECEIVER**.
2. To perform a CW measurement using the tuned receiver mode, connect the equipment as shown in [Figure 7-46](#).

Figure 7-46 Typical Test Setup for Tuned Receiver Mode

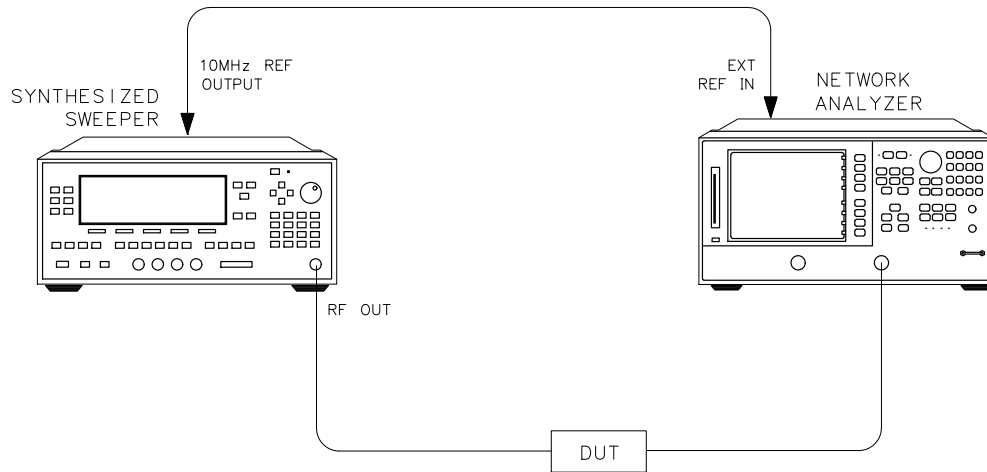

pg66e

Tuned Receiver Mode In-Depth Description

If you press **System** **INSTRUMENT MODE** **TUNED RECEIVER**, the analyzer receiver operates independently of any signal source.

The following features and limitations apply to the tuned receiver mode:

- It is a fully synthesized receiver; it does not phase-lock to any source.
- It functions in all sweep types.
- It requires a synthesized CW source whose timebase is input to the analyzer's external frequency reference.

For more information on using the tuned receiver mode, refer to [“Tuned Receiver Mode” on page 2-27](#).

Frequency Offset Operation (Option 089)

Refer to [“Conversion Loss Using the Frequency Offset Mode” on page 2-13](#) for information on frequency offset operation.

8 Safety and Regulatory Information

General Information

Maintenance

Clean the cabinet, using a dry or damp cloth only.

WARNING To prevent electrical shock, disconnect the analyzer from mains before cleaning. Use a dry cloth or one slightly dampened with water to clean the external case parts. Do not attempt to clean internally.

Assistance

Product maintenance agreements and other customer assistance agreements are available for Agilent Technologies products.

For any assistance, contact your nearest Agilent Technologies Sales and Service Office.

Shipment for Service

If you are sending the instrument to Agilent Technologies for service, ship the analyzer to the nearest service center for repair, including a description of any failed test and any error message. Ship the analyzer using the original or comparable antistatic packaging materials.

Table 8-1 Contacting Agilent

Online assistance: www.agilent.com/find/assist

United States
(tel) 1 800 452 4844

Latin America
(tel) (305) 269 7500
(fax) (305) 269 7599

Canada
(tel) 1 877 894 4414
(fax) (905) 282-6495

Europe
(tel) (+31) 20 547 2323
(fax) (+31) 20 547 2390

New Zealand
(tel) 0 800 738 378
(fax) (+64) 4 495 8950

Japan
(tel) (+81) 426 56 7832
(fax) (+81) 426 56 7840

Australia
(tel) 1 800 629 485
(fax) (+61) 3 9210 5947

Asia Call Center Numbers

Country	Phone Number	Fax Number
Singapore	1-800-375-8100	(65) 836-0252
Malaysia	1-800-828-848	1-800-801664
Philippines	(632) 8426802 1-800-16510170 (PLDT Subscriber Only)	(632) 8426809 1-800-16510288 (PLDT Subscriber Only)
Thailand	(088) 226-008 (outside Bangkok) (662) 661-3999 (within Bangkok)	(66) 1-661-3714
Hong Kong	800-930-871	(852) 2506 9233
Taiwan	0800-047-866	(886) 2 25456723
People's Republic of China	800-810-0189 (preferred) 10800-650-0021	10800-650-0121
India	1-600-11-2929	000-800-650-1101

Safety Symbols

The following safety symbols are used throughout this manual. Familiarize yourself with each of the symbols and its meaning before operating this instrument.

CAUTION Caution denotes a hazard. It calls attention to a procedure that, if not correctly performed or adhered to, would result in damage to or destruction of the instrument. Do not proceed beyond a caution note until the indicated conditions are fully understood and met.

WARNING Warning denotes a hazard. It calls attention to a procedure which, if not correctly performed or adhered to, could result in injury or loss of life. Do not proceed beyond a warning note until the indicated conditions are fully understood and met.

Instrument Markings



The instruction documentation symbol. The product is marked with this symbol when it is necessary for the user to refer to the instructions in the documentation.



The CE mark is a registered trademark of the European Community. (If accompanied by a year, it is when the design was proven.)



The CSA mark is a registered trademark of the Canadian Standards Association.

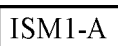

This is a symbol of an Industrial Scientific and Medical Group 1 Class A product.



The C-Tick mark is a registered trademark of the Australian Spectrum Management Agency.



This is a marking to indicate product compliance with the Canadian Interference-Causing Equipment Standard (ICES-001).

Safety Considerations

NOTE This instrument has been designed and tested in accordance with IEC Publication 1010, Safety Requirements for Electronics Measuring Apparatus, and has been supplied in a safe condition. This instruction documentation contains information and warnings which must be followed by the user to ensure safe operation and to maintain the instrument in a safe condition.

Safety Earth Ground

WARNING This is a Safety Class I product (provided with a protective earthing ground incorporated in the power cord). The mains plug shall only be inserted in a socket outlet provided with a protective earth contact. Any interruption of the protective conductor, inside or outside the instrument, is likely to make the instrument dangerous. Intentional interruption is prohibited.

CAUTION Always use the three-prong AC power cord supplied with this product. Failure to ensure adequate earth grounding by not using this cord may cause product damage.

Before Applying Power

CAUTION Install the instrument so that the ON/OFF switch is readily identifiable and is easily reached by the operator. The ON/OFF switch or the detachable power cord is the instrument disconnecting device. It disconnects the mains circuits from the mains supply before other parts of the instrument. Alternately, an externally installed switch or circuit breaker (which is readily identifiable and is easily reached by the operator) may be used as a disconnecting device.

CAUTION Before switching on this instrument, make sure that the analyzer line voltage selector switch is set to the voltage of the power supply and the correct fuse is installed. Assure the supply voltage is in the specified range.

CAUTION If this product is to be energized via an autotransformer make sure the common terminal is connected to the neutral (grounded side of the mains supply).

Servicing

WARNING No operator serviceable parts inside. Refer servicing to qualified personnel. To prevent electrical shock, do not remove covers.

WARNING These servicing instructions are for use by qualified personnel only. To avoid electrical shock, do not perform any servicing unless you are qualified to do so.

WARNING The opening of covers or removal of parts is likely to expose dangerous voltages. Disconnect the instrument from all voltage sources while it is being opened.

WARNING Adjustments described in this document may be performed with power supplied to the product while protective covers are removed. Energy available at many points may, if contacted, result in personal injury.

WARNING The power cord is connected to internal capacitors that may remain live for 10 seconds after disconnecting the plug from its power supply.

WARNING For continued protection against fire hazard replace line fuse only with same type and rating (115V operation: T 5A 125 V UL/CSA; 230V operation: T 4A H 250V IEC). The use of other fuses or material is prohibited.

General

WARNING To prevent electrical shock, disconnect the analyzer from mains before cleaning. Use a dry cloth or one slightly dampened with water to clean the external case parts. Do not attempt to clean internally.

WARNING If this product is not used as specified, the protection provided by the equipment could be impaired. This product must be used in a normal condition (in which all means for protection are intact) only.

CAUTION This product is designed for use in Installation Category II and Pollution Degree 2 per IEC 1010 and 664 respectively.

CAUTION VENTILATION REQUIREMENTS: When installing the product in a cabinet, the convection into and out of the product must not be restricted. The ambient temperature (outside the cabinet) must be less than the maximum operating temperature of the product by 4° C for every 100 watts dissipated in the cabinet. If the total power dissipated in the cabinet is greater than 800 watts, then forced convection must be used.

WARNING Install the instrument according to the enclosure protection provided. This instrument does not protect against the ingress of water. This instrument protects against finger access to hazardous parts within the enclosure.

Compliance with German FTZ Emissions Requirements

This network analyzer complies with German FTZ 526/527 Radiated Emissions and Conducted Emission requirements.

Compliance with German Noise Requirements

This is to declare that this instrument is in conformance with the German Regulation on Noise Declaration for Machines (Laermangabe nach der Maschinenlaermverordnung –3. GSGV Deutschland).

Acoustic Noise Emission/Geraeuschemission	
LpA<70 dB	Lpa<70 dB
Operator Position	am Arbeitsplatz
Normal Operation	normaler Betrieb
per ISO 7779	nach DIN 45635 t. 19

Compliance with Canadian EMC Requirements

This ISM device complies with Canadian ICE-001.

Cet appareil ISM est conforme a la norme NMB du Canada.

Declaration of Conformity

DECLARATION OF CONFORMITY

According to ISO/IEC Guide 22 and CEN/CENELEC EN 45014

Manufacturer's Name: Agilent Technologies, Inc.

Manufacturer's Address: 1400 Fountaingrove Parkway
Santa Rosa, CA 95403-1799
USA

Declares that the products

Product Name: Network Analyzer

Model Number: 8719ES, 8719ET, 8720ES, 8720ET,
8722ES, 8722ET

Product Options: This declaration covers all options of the above products.

Conform to the following product specifications:

EMC: IEC 61326-1:1997+A1:1998 / EN 61326-1:1997+A1:1998

<u>Standard</u>	<u>Limit</u>
CISPR 11:1990 / EN 55011-1991	Group 1, Class A
IEC 61000-4-2:1995+A1998 / EN 61000-4-2:1995	4 kV CD, 8 kV AD
IEC 61000-4-3:1995 / EN 61000-4-3:1995	3 V/m, 80 - 1000 MHz
IEC 61000-4-4:1995 / EN 61000-4-4:1995	0.5 kV sig., 1 kV power
IEC 61000-4-5:1995 / EN 61000-4-5:1996	0.5 kV L-L, 1 kV L-G
IEC 61000-4-6:1996 / EN 61000-4-6:1998	3 V, 0.15 - 80 MHz
IEC 61000-4-11:1994 / EN 61000-4-11:1998	1 cycle, 100%

Safety: IEC 61010-1:1990 + A1:1992 + A2:1995 / EN 61010-1:1993 +A2:1995
CAN/CSA-C22.2 No. 1010.1-92

Supplementary Information:

The products herewith comply with the requirements of the Low Voltage Directive 73/23/EEC and the EMC Directive 89/336/EEC and carry the CE-marking accordingly.



Santa Rosa, CA, USA 6 April 2000

Greg Pfeiffer/Quality Engineering Manager

For further information, please contact your local Agilent Technologies sales office, agent or distributor.

Numerics

- 2-port error corrections, performing, 6-42, 6-70
- 4 Param Displays softkey, 1-18

A

- aborting a print or plot process, 4-33
- absolute
 - ripple test value, 1-88, 1-89
- absolute power, 6-39
- accuracy enhancement, 7-7, 7-37, 7-51
- accurate measurements of electrically long devices
 - cause of measurement problems, 5-8
 - improving measurement results, 5-8
- activating
 - averaging, 5-16
 - chop sweep mode, 5-13
 - display markers, 1-25
 - fixed markers, 1-29
 - limit test, 1-79
- activating the bandwidth test, 1-95
- active channel display, 1-11
- adapter removal, 6-41
- adapter removal calibration (ECal), 6-68–6-74
- adapters
 - minimizing error, 6-47
- adapters, matched, 6-45
- ADC, 7-6
- address menu, 7-78
- addressing two sources, 2-30
- adjusting
 - display colors, 1-22
 - relative velocity factor, 3-12
- AmiPro, using, 4-22
- amplifiers, measuring, 1-52
- amplitude tracking, 2-39
- amplitude, tracking, 1-41
- analog in menu, 7-22
- analyzer display formats, 7-24
 - group delay format, 7-25
 - group delay principles, 7-29
 - imaginary format, 7-29
 - linear magnitude format, 7-27
 - log magnitude format, 7-24
 - phase format, 7-24
 - polar format, 7-27
 - real format, 7-29
 - smith chart format, 7-26
 - SWR format, 7-28
- analyzer internal memory, what you can save, 4-36
- applying power, 8-5
- arrays
 - format, 7-8
 - pre-raw data, 7-6

- raw, 7-7
- ASCII data formats, 4-41
- CITIfile, 4-41
- S2P data format, 4-42
- assigning standards to various TRL classes, 6-51
- assigning standards to various TRM classes, 6-54
- attenuator, 7-13
- attenuator settings, selecting, 1-61
- attenuator, repetitive switching, 7-13
- attenuator, source step, 7-4
- auto sweep time mode, 7-11
- auto sweep time mode, setting, 5-11
- auto-feed, selecting, 4-15
- automatic mode, 7-9
- autostarting sequences, 1-106
- averaging, 7-34
 - isolation, 6-60
- averaging factor, reducing, 5-12
- averaging, activating, 5-16
- averaging, sweep to sweep, 7-6

B

- band
 - adding a frequency, 1-85
 - changing a frequency, 1-84
 - deleting a frequency, 1-85
 - frequency, 1-83
- bandwidth, 1-94
- bandwidth markers
 - displaying, 1-95
- bandwidth test
 - activating, 1-95
 - running, 1-94–1-97
 - setting up limits, 1-92–1-94
- bandwidth testing, 1-92–1-97
- bandwidth value
 - displaying, 1-96
- bandwidth, searching for, 1-41
- basic measurements, making, 1-4
- bilateral device, 6-22, 6-25
- blanking the display, 1-20
- block, receiver, 7-4
- built-in synthesized source, 7-3
 - source step attenuator, 7-4
- built-in test set, 7-4

C

- cables, interconnecting, 5-4
- calculating statistics of measurement data, 1-41
- calculations, ratio, 7-6
- calibrating for non-coaxial devices, 6-50
 - TRL error-correction, 6-50
 - TRM error correction, 6-53

- calibrating for noninsertable devices, 6-40
 - adapter removal, 6-41, 6-68
 - matched adapters, 6-45
 - modifying the cal kit through definition, 6-46
- calibrating the analyzer receiver to measure absolute power, 6-39
- calibration
 - ECal, 6-57–6-67
 - electronic. See ECal
 - power meter, 2-12
- calibration considerations, 6-4
 - calibration standards, 6-5
 - clarifying type-N connector sex, 6-4
 - device measurements, 6-4
 - error-correction stimulus state, 6-9
 - frequency response of calibration standards, 6-6
 - interpolated error correction, 6-8
 - measurement parameters, 6-4
 - omitting isolation calibration, 6-4
 - restarting a calibration, 6-5
 - saving calibration data, 6-5
- calibration data, saving, 6-5, 7-65
- calibration kit menu, 7-58
 - defining standard menus, 7-59
 - label class menu, 7-64
 - label kit menu, 7-64
 - label standard menu, 7-62
 - specify class menu, 7-62
 - specifying offset menu, 7-61
- calibration kit, saving a modified, 7-65
- calibration kits, modifying, 7-57
- calibration routines, 7-54
 - full two-port calibration, 7-55
 - response and isolation calibration, 7-54
 - response calibration, 7-54
 - S11 and S22 one-port calibration, 7-55
 - TRL*/LRM* two-port calibration, 7-55
- calibration standards, 6-5
- calibration techniques
 - improper, 5-4
- calibration, measurement, 7-37
- calibration, receiver, 6-15
- calibration, TRL*/LRM*, 7-66
- calling the next measurement sequence, 2-30
- capabilities
 - mixer measurement, 2-3
- capacitance, fringe, 6-6
- cause of measurement problems, 5-8
- center frequency, setting, 1-35
- changing
 - sequence title, 1-103
 - system bandwidth, 5-16

- changing the ripple limits color, 1-88
 - channel coupling, 7-10
 - channel position softkey, 1-17
 - channel stimulus coupling, 7-14
 - characteristics of the filter, 1-68
 - characterizing a duplexer, 1-49
 - definitions, 1-49
 - procedure, 1-49
 - characterizing microwave systematic errors, 7-41
 - device measurement, 7-45
 - one-port error model, 7-41
 - two-port error model, 7-46
 - choosing
 - display elements, 4-15
 - measurement parameters, 1-4
 - plot speed, 4-18
 - scale, 4-17
 - chop sweep mode, activating, 5-13
 - CITfile, 4-41
 - clarifying type-N connector sex, 6-4
 - clearing a sequence from memory, 1-102
 - color
 - changing the ripple limits, 1-88
 - ripple test message, 1-87
 - color printer, using, 4-6
 - colors of the display, adjusting, 1-22
 - default, 1-22
 - intensity, 1-22
 - modified, 1-23
 - modify colors menu, 1-22
 - command
 - deleting, 1-100
 - inserting, 1-101
 - modifying, 1-101
 - commands that require clean sweep, 1-106
 - commands that sequencing completes before next command, 1-105
 - comma-separated values. See CSV format
 - compensating for directional coupler response, 6-35
 - compliance with German noise requirements, 8-8
 - computer, what you can save, 4-37
 - confidence check, 6-64
 - configuring
 - plot function, 4-10
 - configuring two sources, 2-30
 - connecting
 - device under test, 1-4
 - required test equipment, 1-4
 - connector
 - care, 5-3
 - repeatability, 5-4
 - continuous correction mode, using, 6-37
 - continuous markers, 1-24
 - conversion, 7-7
 - conversion compression using frequency offset mode, 2-40
 - conversion loss, 2-20
 - conversion loss using frequency offset mode, 2-13
 - conversion menu, 7-22
 - copy mode, 7-78
 - correction, sampler/IF, 7-6
 - coupling display markers, 1-31
 - coupling, channel stimulus, 7-14
 - creating
 - flat limit lines, 1-73
 - sequence, 1-98
 - sloping limit line, 1-75
 - user-defined TRL calibration kit, 6-50
 - user-defined TRM calibration kit, 6-53
 - creating single point limits, 1-77
 - crosstalk, 7-40
 - CSV format, saving measurement results in, 4-44
 - CW frequency, setting, 1-38
 - CW time measurements, 3-21
 - CW time sweep, 7-19
- ## D
- data formats, ASCII, 4-41
 - data processing, 7-5
 - processing details, 7-6
 - data trace, 1-19
 - saving to display memory, 1-19
 - decision making functions, 1-112
 - decoupled
 - channel power, 1-13
 - stimulus, 1-13
 - decreasing
 - frequency span, 5-11
 - sweep rate, 5-9
 - time delay, 5-9
 - decrementing the loop counter, 2-32
 - default colors, 1-22
 - defining
 - plot function, 4-15
 - print function, 4-6
 - defining a print function
 - color printer, using, 4-6
 - resetting print parameters to default value, 4-7
 - delay block, electrical, 7-7
 - delay, determining electrical, 6-72
 - delay, electrical, 7-33
 - delay, group, 1-46, 2-35
 - deleting
 - commands, 1-100
 - frequency signals, 6-35
 - line segments, 1-78
 - deleting a file, 4-52
 - all files, 4-52
 - instrument state file, 4-52
 - delta markers, 1-28
 - demodulating the results of the forward transform, 3-22
 - designing your own fixture, 6-49
 - detecting IF delay, 5-10
 - detection, IF, 7-6
 - deviation from linear phase, 1-46
 - device measurement, 7-45
 - device measurements, 6-4
 - device under test
 - measuring, 1-5
 - device under test, connecting, 1-4
 - device, bilateral, 6-22, 6-25
 - device, noninsertable, 6-68
 - direct sampler access configurations, using, 5-17
 - directional coupler response, compensating for, 6-35
 - discrete markers, 1-24
 - disk
 - formatting, 4-54
 - disk, plotting a measurement to, 4-12
 - display elements, choosing, 4-15
 - display functions, 1-10
 - active channel display, 1-11
 - titling, 1-11
 - adjusting colors of the display, 1-22
 - blanking the display, 1-20
 - data trace
 - saving to display memory, 1-19
 - four-channel display
 - 4 Param Displays softkey, 1-18
 - Channel Position softkey, 1-17
 - customizing, 1-17
 - viewing, 1-14
 - measurement data
 - dividing by the memory trace, 1-20
 - subtracting memory trace, 1-20
 - viewing, 1-19
 - memory math functions, 1-19
 - memory trace
 - viewing, 1-19
 - memory traces, 1-19
 - primary measurement
 - dual channel mode with decoupled channel power, 1-13
 - dual channel mode with decoupled stimulus, 1-13
 - primary measurement channels, 1-12
 - viewing, 1-12
 - ratio measurements in channel 1 and 2, to, 1-20
- display intensity, 1-22
- display markers

- coupling, 1-31
 - uncoupling, 1-31
 - display markers, activating, 1-25
 - display memory, 1-19, 7-8
 - display reference value, setting, 1-36
 - display ripple test limits, 1-87
 - display ripple test values, 1-88
 - displayed measurement, titling, 4-32
 - displaying the bandwidth markers, 1-95
 - displaying the bandwidth value, 1-96
 - drift, frequency, 5-5
 - drift, temperature, 5-4
 - dual channel mode with decoupled power, 1-13
 - dual channel mode with decoupled stimulus, 1-13
 - duplexer, characterizing, 1-49
 - dynamic range, increasing, 5-15
- ## E
- ECal, 6-57–6-74
 - adapter removal calibration, 6-68–6-74
 - calibration, 6-57–6-67
 - confidence check, 6-64
 - equipment, 6-58
 - isolation calibration, 6-60
 - manual thru, 6-59
 - module information, 6-63
 - options, 6-59
 - service menu, 6-66
 - edit limits menu, 7-81
 - edit segment menu, 7-81
 - editing a sequence, 1-100
 - deleting commands, 1-100
 - editing line segments, 1-78
 - editing ripple limits, 1-84–1-86
 - electrical
 - length, 1-43
 - offset, 6-6
 - electrical delay, 7-33
 - electrical delay block, 7-7
 - electrical delay, determining, 6-72
 - electrical delay, setting, 1-37
 - electrically long devices, 5-4
 - electronic calibration. See ECal
 - eliminating unwanted mixing and leakage signals, 2-5
 - embedding loop counter value in title, 1-106
 - enhanced frequency response error correction, 6-22
 - enhanced reflection error correction, 6-22, 6-25
 - enhancement, accuracy, 7-37
 - entering the power sensor calibration data, 6-34
 - deleting frequency signals, 6-35
 - editing frequency segments, 6-34
 - error
 - minimizing error while using adapters, 6-47
 - error correcting measurements, 6-10
 - error correction
 - enhanced frequency response, 6-22
 - enhanced reflection, 6-22, 6-25
 - frequency response, 6-12
 - full two-port, 6-29
 - one-port reflection, 6-26
 - error-correction, 1-5
 - stimulus state, 6-9
 - error-correction, vector, 7-7
 - errors, measurement, 7-37
 - exit HPGL mode, 4-26
 - sending to the printer, 4-26
 - external
 - calibration, 5-13
 - disk drive, 4-55
 - R channel inputs, 2-10
- ## F
- fabricating and defining calibration standards for TRL/LRM, 7-72
 - fast 2-port calibration, 5-13
 - fault location measurements using low pass, 3-17
 - features that operate differently in sequence, 1-105
 - feedthrough, RF, 2-47
 - file
 - deleting, 4-52
 - index numbers, 4-45
 - recalling, 4-54
 - renaming, 4-53
 - sequential CSV naming of, 4-45
 - to delete all, 4-52
 - filter, characteristics, 1-68
 - finite impulse width (or rise time), 3-26
 - fixed IF mixer adjustments
 - tuned receiver mode, 2-27
 - fixed IF mixer measurements, 2-27
 - addressing and configuring two sources, 2-30
 - calling the next measurement sequence, 2-30
 - decrementing the loop counter, 2-32
 - frequency list sweep of 26 points, 2-29
 - incrementing the source frequencies, 2-32
 - initializing loop counter value to 26, 2-30
 - labeling the screen, 2-32
 - presetting the instrument, 2-28
 - prompting user to connect mixer test setup, 2-29
 - response calibration, 2-29
 - sequence 1 setup, 2-27
 - sequence 2 setup, 2-32
 - taking data, 2-32
 - tuned receiver mode, 2-29
- fixed markers, 1-29
 - fixtures, 6-48
 - designing your own fixture, 6-49
 - flat limit lines, 1-73
 - floppy disk, what you can save, 4-37
 - form feed sequence, 4-26
 - sending to the printer, 4-26
 - format, 7-8
 - format arrays, 7-8
 - format markers, polar, 1-32
 - formats, analyzer display, 7-24
 - formatting a disk, 4-54
 - forward stepping in edit mode, 1-106
 - forward transform measurements, 3-21
 - demodulating the results of the forward transform, 3-22
 - forward transform range, 3-23
 - interpreting the forward transform horizontal axis, 3-21
 - interpreting the forward transform vertical axis, 3-21
 - forward transform mode, 3-4
 - forward transform range, 3-23
 - four-channel display
 - 4 Param Displays softkey, 1-18
 - Channel Position softkey, 1-17
 - customizing, 1-17
 - viewing, 1-14
 - Freelance, using, 4-23
 - frequency
 - segments, editing, 6-34
 - signals, deleting, 6-35
 - span, decreasing, 5-11
 - span, setting, 1-35
 - frequency bands
 - adding, 1-85
 - changing, 1-84
 - deleting, 1-85
 - setting, 1-83
 - frequency drift, 5-5
 - frequency list sweep of 26 points, 2-29
 - frequency offset mode operation, 2-9
 - frequency offset mode, conversion compression, 2-40
 - frequency offset mode, conversion loss, 2-13
 - frequency offset operation, 7-83
 - frequency range, setting, 1-5
 - frequency range, setting for time domain low pass, 3-15

- frequency response, 7-40
 - frequency response and isolation error corrections, 6-17
 - reflection measurements, 6-19
 - transmission measurements, 6-17
 - frequency response error corrections, 6-12
 - receiver calibration, 6-15
 - response error correction for reflection measurements, 6-12
 - response error correction for transmission measurements, 6-14
 - frequency response of calibration standards, 6-6
 - electrical offset, 6-6
 - fringe capacitance, 6-6
 - fringe capacitance, 6-6
 - full two-port calibration, 7-55
 - full two-port error correction, 6-29
- G**
- gain, 1-57
 - gain compression
 - measuring, 1-53
 - using linear sweep, 1-54
 - gating, 3-34, 7-7
 - selecting gate shape, 3-35
 - setting the gate, 3-34
 - general, 8-7
 - generating files in a loop counter
 - example, 1-116
 - German FTZ emissions requirements, 8-8
 - gobsub sequence command, 1-107
 - GPIO operation
 - address menu, 7-78
 - GPIO STATUS indicators, 7-77
 - local key, 7-76
 - pass control mode, 7-77
 - system controller mode, 7-77
 - talker/listener mode, 7-77
 - using the parallel port, 7-78
 - GPIO mode, 1-107, 7-78
 - graphic files
 - saving measurement results as, 4-46
 - grids
 - moving marker information off the grids, 1-26
 - group delay, 1-46
 - group delay format, 7-25
 - group delay measurements, 2-35
 - group delay principles, 7-29
- H**
- high dynamic range
 - measurement, 2-24
 - swept RF/IF conversion loss, 2-20
 - high dynamic range measurement, 2-24
 - high dynamic range swept RF/IF
 - conversion loss
 - measurement parameters for IF range, 2-20
 - power meter calibration over IF range, 2-20
 - power meter calibration over RF range, 2-23
 - receiver calibration over IF range, 2-22
 - RF frequency range, 2-22
 - high power
 - measurements, 1-59, 1-65
 - high power measurements
 - additional setup, 1-60
 - attenuator settings, selecting, 1-61
 - final setup, 1-63
 - initial setup, 1-59
 - power levels, determining, 1-59
 - power ranges, selecting, 1-61
 - horizontal axis, 3-13, 3-14, 3-16, 3-19, 3-21
 - how RF and IF are defined, 2-7
 - how to
 - make high power measurements, 1-59
 - HPGL
 - compatible printer, 4-21
 - initialization sequence, sending to the printer, 4-26
 - initialization sequence, storing, 4-25
 - HPGL compatible printer, 4-25
 - HPGL/2 compatible printer, 4-10
- I**
- IF bandwidth reduction, 7-35
 - IF bandwidth, setting segment, 7-19
 - IF delay, detecting, 5-10
 - IF detection, 7-6
 - IF range
 - measurement parameters, 2-20
 - power meter calibration, 2-20
 - receiver calibration, 2-22
 - IF, defining, 2-7
 - imaginary format, 7-29
 - improving measurement results, 5-8
 - decreasing the sweep rate, 5-9
 - decreasing time delay, 5-9
 - improving raw source match and load match for TRL*/LRM* calibration, 7-69
 - increase sweep speed
 - using fast 2-port calibration, 5-13
 - increasing dynamic range, 5-15
 - increasing test port input power, 5-15
 - reducing receiver crosstalk, 5-15
 - reducing the receiver noise floor, 5-15
 - increasing measurement accuracy, 5-4
 - connector repeatability, 5-4
 - frequency drift, 5-5
 - interconnecting cables, 5-4
 - performance verification, 5-5
 - reference plane and port extensions, 5-5
 - temperature drift, 5-4
 - increasing sweep speed, 5-10
 - activating chop sweep mode, 5-13
 - decreasing the frequency span, 5-11
 - reducing the averaging factor, 5-12
 - reducing the number of measurement points, 5-12
 - setting the auto sweep time mode, 5-11
 - setting the sweep type, 5-12
 - using external calibration, 5-13
 - using swept list mode, 5-10
 - viewing a single measurement channel, 5-12
 - widening the system bandwidth, 5-12
 - increasing test port input power, 5-15
 - incrementing the source frequencies, 2-32
 - in-depth sequencing information, 1-105
 - autostarting sequences, 1-106
 - commands completed before next sequence begins, 1-105
 - commands that require a clean sweep, 1-106
 - decision making functions, 1-112
 - embedding loop counter value in title, 1-106
 - features that operate differently in a sequence, 1-105
 - forward stepping in edit mode, 1-106
 - gobsub sequence command, 1-107
 - GPIO mode, 1-107
 - limit test decision making, 1-112
 - loop counter decision making, 1-113
 - sequence decision making menu, 1-112
 - sequence size, 1-106
 - sequence that jumps to itself, 1-112
 - sequencing special functions menu, 1-112
 - titles, 1-106
 - TTL I/O menu, 1-108
 - TTL input decision making, 1-108, 1-112
 - TTL out menu, 1-112
 - TTL output for controlling peripherals, 1-108
 - indicators, GPIB STATUS, 7-77
 - initializing loop counter value to 26, 2-30

input ports menu, 7-23
inserting a command, 1-101
insertion phase response, 1-7, 1-8
instrument markings, 8-4
instrument modes, 7-82
 frequency offset operation, 7-83
 network analyzer mode, 7-82
 tuned receiver mode, 7-82
instrument state
 file, deleting, 4-52
 files, 4-47
 re-saving, 4-51
 saving, 4-38, 7-65
 saving and recalling, 4-36
interconnecting cables, 5-4
internal memory, 4-36
internal R channel inputs, 2-10
interpolated error correction, 6-8
interpolation in power meter calibration, 6-33
interpreting
 bandpass reflection response
 horizontal axis, 3-13
 bandpass reflection response vertical axis, 3-13
 bandpass transmission response
 horizontal axis, 3-14
 bandpass transmission response vertical axis, 3-14
 forward transform horizontal axis, 3-21
 forward transform vertical axis, 3-21
 low pass response horizontal axis, 3-16
 low pass response vertical axis, 3-16
 low pass step transmission response
 horizontal axis, 3-19
 low pass step transmission response vertical axis, 3-19
introduction to time domain measurements, 3-3
isolation, 7-40, 7-68
 averaging, 6-60
 calibrating using ECal, 6-60
 calibration, omitting, 6-4
 error corrections and frequency response, 6-17
isolation example measurements, 2-45
 LO to RF isolation, 2-45
 RF feedthrough, 2-47
 SWR/return loss, 2-50

J
jpeg files, saving results as, 4-46

K
knowing the instrument modes, 7-82

L
labeling the screen, 2-32
leakage signals, eliminating unwanted, 2-5
limit line operation, 7-80
 edit limits menu, 7-81
 edit segment menu, 7-81
 offset limits menu, 7-81
limit lines
 creating flat limit lines, 1-73
 creating single point limits, 1-77
 editing line segments, 1-78
 measurement parameters, 1-72
 offsetting limit lines, 1-79
 running a limit test, 1-79
 sloping limit line, 1-75
 using to test a device, 1-72
limit test
 decision making, 1-112
 example sequence, 1-118
limit test, running, 1-79
 activating the limit test, 1-79
 reviewing the limit line segments, 1-79
line segments, editing, 1-78
 deleting line segments, 1-78
line types, selecting, 4-16
linear frequency sweep, 7-15
linear magnitude format, 7-27
linear phase, deviation, 1-46
linear sweep, 1-54
linearity, phase, 2-35
list values, printing or plotting, 4-34
LO frequency accuracy and stability, 2-10
LO to RF isolation, 2-45
load match, 7-40, 7-69
load mismatches, minimizing, 2-4
loading a sequence from a disk, 1-104
local key, 7-76
log magnitude format, 7-24
logarithmic frequency sweep, 7-15
loop counter
 decision making, 1-113
 example sequence, 1-115
 value, 2-30
loss of power meter calibration data, 6-33
low pass impulse mode, 3-19
lower stopband parameters, 1-68

M
magnitude
 measuring, 1-7
 measuring response, 1-7
maintaining testport output power during sweep retrace, 5-7

maintenance, 8-2
making a basic measurement, 1-4
 choosing measurement parameters, 1-4
 connecting required test equipment, 1-4
 connecting the device under test, 1-4
 error-correction, 1-5
 frequency range, setting, 1-5
 measurement, setting, 1-5
 measuring the device under test, 1-5
 outputting measurement results, 1-6
 source power, setting, 1-5
making non-coaxial measurements, 6-48
 fixtures, 6-48
making reflection response measurements, 3-9
making transmission response measurements, 3-5
manual mode, 7-9
manual sweep time mode, 7-11
manual thru, 6-59
margin
 ripple test value, 1-88, 1-91
markers, 1-24
 calculating statistics of measurement data, 1-41
 continuous, 1-24
 coupling display markers, 1-31
 CW frequency, setting, 1-38
 delta markers, 1-28
 discrete, 1-24
 display markers
 activating, 1-25
 fixed marker
 activating, 1-29
 moving marker information off of the grids, 1-26
 polar format markers, 1-32
 setting measurement parameters, 1-34
 smith chart markers, 1-33
 specific amplitude, searching for, 1-39
 uncoupling display markers, 1-31
masking, 3-25
matched adapters, 6-45
maximum amplitude, searching for, 1-39
maximum and minimum, 1-94
maximum bandwidth, 1-94
measurement
 accuracy, increasing, 5-4
 calibration, power meter, 6-33
 fault location using low pass, 3-17
 high dynamic range, 2-24
 isolation example, 2-45
 non-coaxial, 6-48

- plotting to a disk, 4-12
 - printing or plotting results, 4-3
 - reflection response, 3-9
 - results, outputting, 1-6
 - results, saving, 4-39
 - results, saving graphically, 4-46
 - setting, 1-5
 - time domain, 3-3
 - transmission measurements in time
 - domain low pass, 3-18
 - transmission response, 3-5
 - measurement calibration, 7-37
 - accuracy enhancement, 7-37, 7-51
 - characterizing microwave systematic errors, 7-41
 - measurement errors, 7-37
 - measurement considerations, 2-4
 - eliminating unwanted mixing and leakage signals, 2-5
 - frequency offset mode operation, 2-9
 - how RF and IF are defined, 2-7
 - internal and external R channel inputs, 2-10
 - LO frequency accuracy and stability, 2-10
 - minimizing source and load mismatches, 2-4
 - power meter calibration, 2-12
 - reducing the effect of spurious responses, 2-5
 - measurement data, 1-19, 1-20
 - dividing by the memory trace, 1-20
 - viewing, 1-19
 - measurement data trace, 1-20
 - subtracting memory trace, 1-20
 - measurement error
 - crosstalk, 7-40
 - frequency response, 7-40
 - isolation, 7-40
 - load match, 7-40
 - measurement errors
 - directivity, 7-38
 - source match, 7-39
 - measurement parameters, 1-68, 6-4
 - center frequency, setting, 1-35
 - choosing, 1-4
 - display reference value, setting, 1-36
 - electrical delay, setting, 1-37
 - for IF range, 2-20
 - frequency span, setting, 1-35
 - lower stopband parameters, 1-68
 - markers, setting with, 1-34
 - passband parameters, 1-69
 - start frequency, setting, 1-34
 - stop frequency, setting, 1-34
 - upper stopband parameters, 1-69
 - measurements
 - basic, 1-4
 - high power, 1-59, 1-65
 - phase or group delay, 2-35
 - measuring
 - device under test, 1-5
 - gain and reverse isolation
 - simultaneously, 1-57
 - insertion phase response, 1-7, 1-8
 - separate transmission paths through the test device using low pass impulse mode, 3-19
 - small signal transient response using low pass step, 3-18
 - measuring amplifiers, 1-52
 - high power measurements, 1-65
 - high power measurements making, 1-59
 - measuring gain and reverse isolation
 - simultaneously, 1-57
 - measuring gain compression, 1-53
 - measuring electrical length, 1-43
 - measuring gain compression, 1-53
 - linear sweep, 1-54
 - using linear sweep, 1-54
 - measuring magnitude, 1-7
 - magnitude response, 1-7
 - measuring phase distortion, 1-43, 1-45
 - deviation from linear phase, 1-46
 - group delay, 1-46
 - memory math functions, 1-19
 - memory trace, 1-19, 1-20
 - viewing, 1-19
 - memory, display, 7-8
- menu
 - address, 7-78
 - analog in, 7-22
 - calibration kit, 7-58
 - conversion, 7-22
 - edit limits, 7-81
 - edit segment, 7-81
 - input ports menu, 7-23
 - offset limits, 7-81
 - segment, 7-16
 - S-parameter, 7-22
 - stepped edit list, 7-16
 - stepped edit subsweep, 7-16
 - swept edit list, 7-17
 - swept edit subsweep, 7-17
 - microprocessor, 7-4
 - microwave connector care, 5-3
 - microwave systematic errors,
 - characterizing, 7-41
 - minimizing
 - error when using adapters, 6-47
 - source and load mismatches, 2-4
 - minimum allowable stop frequencies, 3-15
 - minimum amplitude, searching for, 1-39
 - minimum bandwidth, 1-94
 - minimum sweep time, 7-11
- mixer
 - fixed IF measurements, 2-27
 - measurement, 2-3
 - measurement diagram, using, 2-17, 2-23
 - mixing signals, eliminating unwanted, 2-5
- mode
 - auto sweep time, 5-11, 7-11
 - chop sweep, 5-13
 - continuous correction, 6-37
 - copy, 7-78
 - frequency offset, 2-40
 - GPIO, 7-78
 - low pass impulse, 3-19
 - manual sweep time, 7-11
 - network analyzer, 7-82
 - pass control, 7-77
 - system controller, 7-77
 - talker/listener, 7-77
 - time domain bandpass, 3-12
 - time domain low pass, 3-15
 - tuned receiver, 7-82
 - model
 - one-port error, 7-41
 - two-port error, 7-46
 - modified colors, 1-23
 - recalling, 1-23
 - saving, 1-23
 - modify colors menu, 1-22
 - modifying
 - cal kit through definition, 6-46
 - command, 1-101
 - standard definitions, 6-50
 - modifying calibration kits, 7-57
 - calibration kit menu, 7-58
 - saving to a disk, 7-65
 - verifying performance, 7-65
 - module information, 6-63
- multiple
 - measurements per page, plotting from a disk, 4-28
 - measurements, plotting on a full page, 4-29
 - plots, outputting to a single page using a plotter, 4-27
- N**
- N dB Point, 1-94
 - names for CSV files, 4-45
 - naming files generated by a sequence, 1-103
 - network analyzer mode, 7-82
 - noise reduction techniques, 7-34

- averaging, 7-34
 - IF bandwidth reduction, 7-35
 - smoothing, 7-35
 - non-coaxial
 - making measurements, 6-48
 - non-coaxial devices, calibrating for, 6-50
 - noninsertable device, 6-68
 - noninsertable devices, calibrating for, 6-40
- O**
- offset and scale, 7-8
 - offset limits menu, 7-81
 - offset, electrical, 6-6
 - offsetting limit lines, 1-79
 - omitting isolation calibration, 6-4
 - one-port calibration, S11 and S22, 7-55
 - one-port error model, 7-41
 - one-port reflection error correction, 6-26
 - operating parameters, printing or plotting, 4-34
 - operation, frequency offset, 7-83
 - operation, GPIB, 7-76
 - operation, limit line, 7-80
 - operation, system, 7-3
 - operation, trace math, 7-7
 - output power, 7-9
 - power coupling options, 7-10
 - understanding power ranges, 7-9
 - outputting
 - measurement results, 1-6
 - multiple plots to a single page using a plotter, 4-27
 - plot files, 4-13
 - plot files from a PC to a plotter, 4-24
 - single page plots using a printer, 4-26
 - outputting plot files from a PC to an HPGL compatible printer, 4-25
 - sending the exit HPGL mode and form feed sequence to the printer, 4-26
 - sending the HPGL initialization sequence to the printer, 4-26
 - sending the plot file to the printer, 4-26
 - storing the exit HPGL mode and form feed sequence, 4-26
 - storing the HPGL initialization sequence, 4-25
- P**
- page quadrants, plotting measurements in, 4-30
 - parameters
 - lower stopband, 1-68
 - measurement, 1-4, 1-68, 6-4
 - passband, 1-69
 - upper stopband, 1-69
 - pass control mode, 7-77
 - passband parameters, 1-69
 - PC interface unit, 6-58
 - PC, to view files on, 4-22
 - pen numbers and colors, selecting, 4-16
 - pen plotter, 4-19, 4-20
 - plotting to, 4-11
 - performance verification, 5-5
 - performance, verifying, 7-65
 - performing
 - 2-port error corrections, 6-42, 6-70
 - TRL calibration, 6-52
 - TRM calibration, 6-55
 - peripheral equipment, required, 7-4
 - per-row data arrays, 7-6
 - phase
 - linearity, 2-35
 - measurements, 2-35
 - tracking, 2-39
 - phase distortion, 1-43, 1-45
 - phase format, 7-24
 - phase or group delay measurements, 2-35
 - phase linearity and group delay, 2-35
 - phase measurements, 2-35
 - places where you can save, 4-36
 - plot
 - aborting a process, 4-33
 - plot files
 - outputting from a PC to a plotter, 4-24
 - outputting from a PC to an HPGL compatible printer, 4-25
 - sending to the printer, 4-26
 - to output, 4-13
 - to view on a PC, 4-22
 - plot function, configuring, 4-10
 - plotting to a pen plotter, 4-11
 - plotting to an HPGL/2 compatible printer, 4-10
 - plot function, defining, 4-15
 - choosing display elements, 4-15
 - choosing plot speed, 4-18
 - choosing scale, 4-17
 - resetting plotting parameters to default values, 4-18
 - selecting auto-feed, 4-15
 - selecting line types, 4-16
 - selecting pen numbers and colors, 4-16
 - plot speed, choosing, 4-18
 - plotting
 - measurement results, 4-3
 - measurement to a disk, 4-12
 - measurements in page quadrants, 4-30
 - multiple measurements on a full page, 4-29
 - multiple measurements per page from a disk, 4-28
 - multiple measurements per page using a pen plotter, 4-20
 - one measurements per page using a pen plotter, 4-19
 - parameters, resetting to default values, 4-18
 - plotting to an HPGL compatible printer, 4-21
 - solving problems, 4-35
 - plotting a measurement to a disk to output the plot files, 4-13
 - polar format, 7-27
 - polar format markers, 1-32
 - port extensions, 5-5
 - power coupling options, 7-10
 - channel coupling, 7-10
 - test port coupling, 7-10
 - power levels, determining, 1-59
 - power meter
 - calibration, 2-12
 - calibration over IF range, 2-20
 - calibration over RF range, 2-23
 - power meter measurement calibration, 6-33
 - calibrating the analyzer receiver to measure absolute power, 6-39
 - compensating for directional coupler response, 6-35
 - entering the power sensor calibration data, 6-34
 - interpolation in power meter calibration, 6-33
 - loss of power meter calibration data, 6-33
 - using continuous correction mode, 6-37
 - using sample-and-sweep correction mode, 6-36
 - power ranges, 7-9
 - automatic mode, 7-9
 - manual mode, 7-9
 - power ranges, selecting, 1-61
 - power sensor calibration data, entering, 6-34
 - power sweep, 7-19
 - power, output, 7-9
 - primary measurement channels, viewing, 1-12
 - principles, group delay, 7-29
 - print
 - aborting a process, 4-33
 - print function
 - configuring, 4-4
 - defining, 4-6
 - printer

- color printer, using, 4-6
 - HPGL compatible printer, 4-21, 4-25
 - HPGL/2 compatible printer, 4-10
 - printing
 - measurement results, 4-3
 - multiple measurements per page, 4-9
 - one measurement per page, 4-8
 - parameters, resetting to default values, 4-7
 - sequence, 1-104
 - solving problems, 4-35
 - printing or plotting the list values or operating parameters, 4-34
 - entire list of values, 4-34
 - single page of values, 4-34
 - procedure
 - high power measurements, 1-59
 - procedure, TRL calibration, 7-70
 - procedures for error correcting measurements, 6-10
 - types of error correction, 6-10
 - processing details, 7-6
 - accuracy enhancement, 7-7
 - ADC, 7-6
 - conversion, 7-7
 - display memory, 7-8
 - electrical delay block, 7-7
 - format, 7-8
 - format arrays, 7-8
 - gating, 7-7
 - IF detection, 7-6
 - pre-raw data arrays, 7-6
 - ratio calculations, 7-6
 - raw arrays, 7-7
 - sampler/IF correction, 7-6
 - scale and offset, 7-8
 - smoothing, 7-8
 - sweep-to-sweep averaging, 7-6
 - trace math operation, 7-7
 - transform, 7-7
 - vector error-correction, 7-7
 - processing, data, 7-5
 - prompting user to connect mixer test setup, 2-29
 - purging a sequence from a disk, 1-104
- R**
- R channel inputs, internal and external, 2-10
 - range, 3-29
 - forward transform, 3-23
 - resolution, 3-33
 - ratio calculations, 7-6
 - ratio measurements in channel 1 and 2, to, 1-20
 - raw arrays, 7-7
 - raw source match, 7-69
 - real format, 7-29
 - recall time, reducing, 5-18
 - recalling a file, 4-54
 - solving problems, 4-55
 - recalling instrument states, 4-36
 - receiver
 - calibration, 6-15
 - crosstalk, reducing, 5-15, 5-18
 - noise floor, reducing, 5-15
 - receiver block, 7-4
 - reducing
 - averaging factor, 5-12
 - effect of spurious responses, 2-5
 - number of measurement points, 5-12
 - reducing recall time, 5-18
 - reducing trace noise, 5-16
 - activating averaging, 5-16
 - changing system bandwidth, 5-16
 - reduction, IF bandwidth, 7-35
 - reference plane and port extensions, 5-5
 - reflection measurements
 - response and isolation error correction, 6-19
 - response error correction, 6-12
 - reflection measurements in time domain
 - low pass, 3-16
 - interpreting the low pass response horizontal axis, 3-16
 - interpreting the low pass response vertical axis, 3-16
 - reflection measurements using bandpass
 - interpreting the band pass reflection response vertical axis, 3-13
 - reflection measurements using bandpass mode, 3-12
 - interpreting the bandpass reflection response horizontal axis, 3-13
 - reflection response measurements, making, 3-9
 - relative velocity factor, adjusting, 3-12
 - removing adapter delay, 6-42
 - removing the effect of an adapter, 6-73
 - renaming a file, 4-53
 - repeatability, connector, 5-4
 - repetitive switching of the attenuator, 7-13
 - required peripheral equipment, 7-4
 - required test equipment, connecting, 1-4
 - requirements for TRL standards, 7-70
 - re-saving an instrument state, 4-51
 - resetting
 - plotting parameters to default values, 4-18
 - printing parameters to default values, 4-7
- resolution, 3-31**
- range resolution, 3-33
 - response resolution, 3-31
- response**
- calibration, 2-29
 - error correction for reflection measurements, 6-12
 - error correction for transmission measurements, 6-14
 - magnitude, 1-7
 - resolution, 3-31
- response and isolation calibration, 7-54**
- response and isolation error correction for reflection measurements, 6-19**
- response calibration, 7-54**
- restarting a calibration, 6-5**
- reverse isolation, 1-57**
- reviewing the limit line segments, 1-79**
- RF feedthrough, 2-47**
- RF frequency range, 2-22**
- using the calculation, 2-22
 - using the mixer measurement diagram, 2-17, 2-23
- RF range**
- power meter calibration, 2-23
- RF, defining, 2-7**
- ripple limit testing, 1-81–1-91**
- ripple limits**
- editing, 1-84–1-86
 - running the test, 1-86–1-91
 - setting, 1-81–1-84
- ripple test**
- absolute value, 1-89
 - displaying limits, 1-87
 - displaying values, 1-88
 - frequency bands, 1-83
 - margin value, 1-91
 - message color, 1-87
 - starting and stopping, 1-86
- running a bandwidth test, 1-94–1-97**
- running a limit test, 1-79**
- running a sequence, 1-100**
- running the ripple limits test, 1-86–1-91**
- S**
- S11 and S22 one-port calibration, 7-55
 - S2P data format, 4-42
 - safety considerations, 8-5
 - before applying power, 8-5
 - compliance with German FTZ emissions requirements, 8-8
 - compliance with German noise requirements, 8-8
 - general, 8-7
 - safety earth ground, 8-5
 - servicing, 8-6
 - safety earth ground, 8-5

- safety symbols, 8-4
 - sample-and-sweep correction mode, using, 6-36
 - sampler/IF correction, 7-6
 - saving
 - calibration data, 6-5, 7-65
 - data trace, 1-19
 - instrument state, 4-38, 7-65
 - measurement results, 4-39
 - measurement results graphically, 4-46
 - modified calibration kits, 7-65
 - to a disk, 7-65
 - saving a file
 - solving problems, 4-55
 - saving and recalling instrument states, 4-36
 - places where you can save, 4-36
 - what you can save to a computer, 4-37
 - what you can save to a floppy disk, 4-37
 - what you can save to the analyzer's internal memory, 4-36
 - saving measurement results
 - ASCII data formats, 4-41
 - instrument state files, 4-47
 - scale and offset, 7-8
 - scale, choosing, 4-17
 - searching for specific amplitude, 1-39
 - segment menu, 7-16
 - segment power, setting, 7-18
 - selecting
 - auto-feed, 4-15
 - gate shape, 3-35
 - line types, 4-16
 - pen numbers and colors, 4-16
 - selecting sweep modes, 7-19
 - sending the exit HPGL mode and form feed sequence to the printer, 4-26
 - sending the HPGL initialization sequence to the printer, 4-26
 - sending the plot file to the printer, 4-26
 - sequence
 - changing the title, 1-103
 - clearing from memory, 1-102
 - creating, 1-98
 - decision making menu, 1-112
 - editing, 1-100
 - generating files in a loop counter example, 1-116
 - in-depth information, 1-105
 - jumps to itself, 1-112
 - limit test example, 1-118
 - loading from a disk, 1-104
 - loop counter example, 1-115
 - naming files, 1-103
 - printing, 1-104
 - purging from a disk, 1-104
 - running, 1-100
 - size, 1-106
 - stopping, 1-100
 - storing to disk, 1-104
 - sequencing
 - special functions menu, 1-112
 - test, 1-98
 - service menu (ECal), 6-66
 - servicing, 8-6
 - setting
 - auto sweep time mode, 5-11
 - frequency range for time domain low pass, 3-15
 - gate, 3-34
 - setting ripple limits, 1-81–1-84
 - setting segment IF bandwidth, 7-19
 - setting segment power, 7-18
 - setting the sweep type, 5-12
 - setting up bandwidth test limits, 1-92–1-94
 - shipment for service, 8-2
 - sidelobes, 3-26
 - single page plots, outputting using a printer, 4-26
 - single point limits, 1-77
 - sloping limit line, 1-75
 - small signal transient response, measuring, 3-18
 - smith chart format, 7-26
 - smith chart markers, 1-33
 - smoothing, 7-8, 7-35
 - softkey
 - 4 Param Displays, 1-18
 - channel position, 1-17
 - solving problems with printing or plotting, 4-35
 - solving problems with saving or recalling files, 4-55
 - using an external disk drive, 4-55
 - source attenuator switch protection, 7-13
 - repetitive switching of the attenuator, 7-13
 - source match, 7-39
 - source match and load match, 7-68
 - source mismatches, minimizing, 2-4
 - source power, setting, 1-5
 - source step attenuator, 7-4
 - S-parameter menu
 - analog in menu, 7-22
 - conversion menu, 7-22
 - S-parameters, 7-20
 - S-parameter menu, 7-22
 - understanding, 7-20
 - S-parameters menu
 - input ports menu, 7-23
 - specific amplitude, 1-39
 - bandwidth, searching for, 1-41
 - maximum amplitude, searching for, 1-39
 - minimum amplitude, searching for, 1-39
 - target amplitude, searching for, 1-40
 - tracking the amplitude, 1-41
- spreadsheet, saving test file for a, 4-44
- spurious responses, reducing the effect of, 2-5
- standards, calibration, 6-5
- start frequency, setting, 1-34
- starting the ripple test, 1-86
- statistics of measurement data, calculating, 1-41
- stepped edit list menu, 7-16
- stepped edit subsweep menu, 7-16
- stepped list frequency sweep, 7-15
- segment menu, 7-16
 - stepped edit list menu, 7-16
 - stepped edit subsweep menu, 7-16
- stepped list mode, 1-67
- stimulus state, error-correction, 6-9
- stop frequencies, minimum allowable, 3-15
- stop frequency, setting, 1-34
- stopping a sequence, 1-100
- stopping the ripple test, 1-86
- storing
 - exit HPGL mode and form feed sequence, 4-26
 - HPGL initialization sequence, 4-25
 - sequence on a disk, 1-104
- sweep
 - rate, decreasing, 5-9
 - retrace, 5-7
 - speed, increasing, 5-10
 - type, setting, 5-12
- sweep time, 7-11
- auto sweep time mode, 7-11
 - manual sweep time mode, 7-11
 - minimum sweep time, 7-11
- sweep types, 7-15
- CW time sweep, 7-19
 - linear frequency sweep, 7-15
 - logarithmic frequency sweep, 7-15
 - power sweep, 7-19
 - selecting sweep modes, 7-19
 - stepped list frequency sweep, 7-15
 - swept list frequency sweep, 7-17
 - sweep-to-sweep averaging, 7-6
 - swept edit list menu, 7-17
 - swept edit subsweep menu, 7-17
 - swept list frequency sweep, 7-17
 - setting segment IF bandwidth, 7-19
 - setting segment power, 7-18
 - swept edit list menu, 7-17

- swept edit subsweep menu, [7-17](#)
 - swept list mode
 - calibrate, [1-70](#)
 - characteristics of the filter, [1-68](#)
 - device under test, connect, [1-67](#)
 - measure, [1-70](#)
 - measurement parameters, [1-68](#)
 - stepped list mode, [1-67](#)
 - to test a device, [1-67](#)
 - swept list mode, using, [5-10](#)
 - swept RF/IF conversion loss, high dynamic range, [2-20](#)
 - switch protection, source attenuator, [7-13](#)
 - SWR format, [7-28](#)
 - SWR/return loss, [2-50](#)
 - synthesized source, built-in, [7-3](#)
 - system
 - bandwidth, changing, [5-16](#)
 - bandwidth, widening, [5-12](#)
 - system controller mode, [7-77](#)
 - system operation, [7-3](#)
 - built-in synthesized source, [7-3](#)
 - built-in test set, [7-4](#)
 - microprocessor, [7-4](#)
 - receiver block, [7-4](#)
 - required peripheral equipment, [7-4](#)
 - systematic errors, [7-41](#)
- ## T
- taking care of microwave connectors, [5-3](#)
 - talker/listener mode, [7-77](#)
 - target amplitude, searching for, [1-40](#)
 - temperature drift, [5-4](#)
 - terminology, TRL, [7-66](#)
 - test
 - bandwidth, [1-92–1-97](#)
 - ripple limit, [1-81–1-91](#)
 - test port coupling, [7-10](#)
 - test port input power, increasing, [5-15](#)
 - test sequencing, [1-98](#)
 - changing the sequence title, [1-103](#)
 - clearing a sequence from memory, [1-102](#)
 - creating a sequence, [1-98](#)
 - editing a sequence, [1-100](#)
 - generating files in a loop counter example, [1-116](#)
 - in-depth sequencing information, [1-105](#)
 - inserting a command, [1-101](#)
 - limit test example sequence, [1-118](#)
 - loading a sequence from a disk, [1-104](#)
 - loop counter example sequence, [1-115](#)
 - modifying a command, [1-101](#)
 - naming files generated by a sequence, [1-103](#)
 - printing a sequence, [1-104](#)
 - purging a sequence from a disk, [1-104](#)
 - running a sequence, [1-100](#)
 - stopping a sequence, [1-100](#)
 - storing a sequence on a disk, [1-104](#)
 - using to test a device, [1-114](#)
 - test set, built-in, [7-4](#)
 - testport output power, [5-7](#)
 - text file, saving measurements as a, [4-44](#)
 - thru, manual, [6-59](#)
 - time delay, decreasing, [5-9](#)
 - time domain bandpass mode, [3-4](#), [3-12](#)
 - adjusting the relative velocity factor, [3-12](#)
 - reflection measurements using bandpass mode, [3-12](#)
 - transmission measurements using bandpass mode, [3-14](#)
 - time domain low pass impulse mode, [3-4](#)
 - time domain low pass mode, [3-15](#)
 - fault location measurements using low pass, [3-17](#)
 - minimum allowable stop frequencies, [3-15](#)
 - reflection measurements in time domain low pass, [3-16](#)
 - setting frequency range for time domain low pass, [3-15](#)
 - transmission measurements in time domain low pass, [3-18](#)
 - time domain low pass step mode, [3-4](#)
 - time domain measurements, introduction, [3-3](#)
 - forward transform mode, [3-4](#)
 - time domain bandpass mode, [3-4](#)
 - time domain low pass impulse mode, [3-4](#)
 - time domain low pass step mode, [3-4](#)
 - time stamp, [4-33](#)
 - title, [1-106](#)
 - title, display, [1-11](#)
 - titling the displayed measurement, [4-32](#)
 - to produce a time stamp, [4-33](#)
 - trace math operation, [7-7](#)
 - trace noise, reducing, [5-16](#)
 - tracking, [7-40](#)
 - tracking the amplitude, [1-41](#)
 - tracking, amplitude and phase, [2-39](#)
 - transform, [7-7](#)
 - transforming CW time measurements into the frequency domain, [3-21](#)
 - forward transform measurements, [3-21](#)
 - transmission measurements in time domain low pass, [3-18](#)
 - interpreting the low pass step transmission response horizontal axis, [3-19](#)
 - interpreting the low pass step transmission response vertical axis, [3-19](#)
 - measuring separate transmission paths through the test device using low pass impulse mode, [3-19](#)
 - measuring small signal transient response using low pass step, [3-18](#)
 - transmission measurements using bandpass mode, [3-14](#)
 - interpreting the bandpass transmission response horizontal axis, [3-14](#)
 - interpreting the bandpass transmission response vertical axis, [3-14](#)
 - transmission measurements, response and isolation error correction, [6-17](#)
 - transmission measurements, response error correction, [6-14](#)
 - transmission response measurements, making, [3-5](#)
 - TRL calibration, performing, [6-52](#)
 - TRL error correction
 - assigning standards to various TRL classes, [6-51](#)
 - label the calibration kit, [6-51](#)
 - label the classes, [6-51](#)
 - performing the TRL calibration, [6-52](#)
 - TRL error-correction, [6-50](#)
 - creating a user-defined TRL calibration kit, [6-50](#)
 - TRL options, [7-74](#)
 - TRL terminology, [7-66](#)
 - TRL* error model, [7-67](#)
 - TRL*/LRM* calibration, [7-66](#)
 - fabricating and defining calibration standards for TRL/LRM, [7-72](#)
 - how TRL*/LRM* works, [7-67](#)
 - improving raw source match and load match for TRL*/LRM* calibration, [7-69](#)
 - isolation, [7-68](#)
 - source match and load match, [7-68](#)
 - TRL calibration procedure, [7-70](#)
 - TRL options, [7-74](#)
 - TRL standards, requirements, [7-70](#)
 - TRL terminology, [7-66](#)
 - TRL* error model, [7-67](#)
 - TRL*/LRM* two-port calibration, [7-55](#)

TRM error correction, [6-53](#)
 assigning standards to various TRM classes, [6-54](#)
 creating a user-defined TRM calibration kit, [6-53](#)
 labeling the calibration kit, [6-54](#)
 labeling the classes, [6-54](#)
 modifying the standard definitions, [6-53](#)
 performing the TRM calibration, [6-55](#)

TTL
 I/O menu, [1-108](#)
 input decision making, [1-108](#)
 out menu, [1-112](#)
 output for controlling peripherals, [1-108](#)

tuned receiver mode, [2-27](#), [2-29](#), [7-82](#)
 in-depth description, [7-83](#)
 test setup, typical, [7-82](#)

two sources
 addressing and configuring, [2-30](#)

two-port calibration, full, [7-55](#)

two-port calibration, TRL*/LRM*, [7-55](#)

two-port error model, [7-46](#)

type-N connector sex
 clarifying, [6-4](#)

types of error correction, [6-10](#)

U

uncoupling display markers, [1-31](#)

understanding power ranges, [7-9](#)

understanding S-parameters, [7-20](#)

upper stopband parameters, [1-69](#)

using continuous correction mode, [6-37](#)

using direct sampler access
 configurations, [5-17](#)

using external calibration, [5-13](#)

using fast 2-port calibration, [5-13](#)

using sample-and-sweep correction mode, [6-36](#)

using swept list mode, [5-10](#)
 detecting IF delay, [5-10](#)

using the parallel port, [7-78](#)
 copy mode, [7-78](#)
 GPIO mode, [7-78](#)

V

vector error-correction, [7-7](#)

verification, performance, [5-5](#)

verifying performance, [7-65](#)

vertical axis, [3-13](#), [3-14](#), [3-16](#), [3-19](#), [3-21](#)

viewing a single measurement channel, [5-12](#)

viewing plot files on a PC, [4-22](#)
 using AmiPro, [4-22](#)
 using Freelance, [4-23](#)

W

what you can save to a computer, [4-37](#)

what you can save to a floppy disk, [4-37](#)

what you can save to the analyzer's internal memory, [4-36](#)

widening the system bandwidth, [5-12](#)

windowing, [3-26](#)
 finite impulse width (or rise time), [3-26](#)
 sidelobes, [3-26](#)