

Agilent Electronic Calibration (ECal) Modules for Vector Network Analyzers

N4690 Series, 2-port Microwave ECal
85090 Series, 2-port RF ECal
N4430 Series, 4-port ECal

Technical Overview

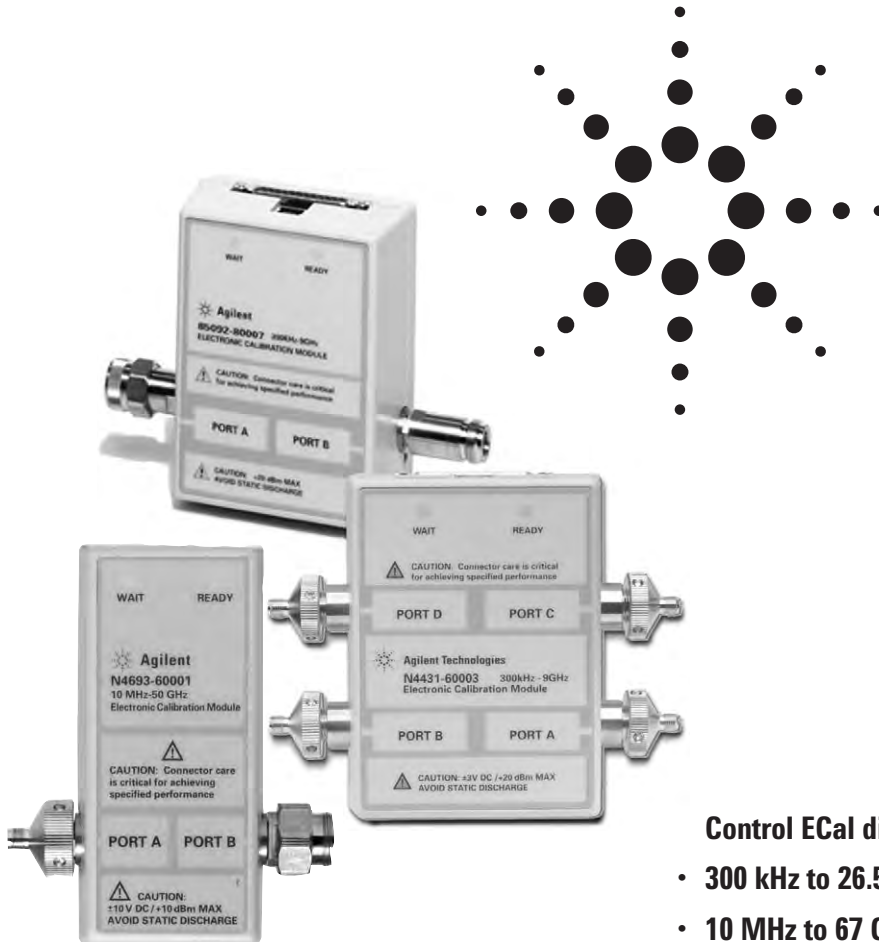

Control ECal directly from the PNA or ENA

- **300 kHz to 26.5 GHz module**
- **10 MHz to 67 GHz module**
- **Nine connector types available**
- **Ideal calibration technique for manufacturing**
- **Mixed-connectors available (Type-N 50 ohm, 3.5 mm and 7-16)**



Agilent Technologies

Introduction

Electronic calibration (ECal) is a precision, single-connection, one-, two-, three-, or four-port calibration technique for your vector network analyzer. ECal modules use fully traceable and verifiable electronic impedance standards. The modules are state-of-the-art, solid-state devices with programmable and highly repeatable impedance states. ECal modules are transfer standards that provide consistent calibrations and eliminate operator errors while bringing convenience and simplicity to your calibration routine. Consistent calibrations provide consistent measurements.

ECal replaces the traditional calibration technique, which uses mechanical standards. With mechanical standards you are required to make numerous connections to the test ports for a single calibration. These traditional calibrations require intensive operator interaction, which is prone to error. With ECal, a full one- to four-port calibration can be accomplished with a single connection to the ECal module and minimal operator interaction. This results in faster and more repeatable calibrations.

Mixed-connector options are available for the 85092C, 85093C, 85098C, N4431B and N4432A. The available connectors are Type-N 50 ohms, 3.5mm, and 7-16.

Accurate transfer standards

The ECal modules are transfer standards capable of transferring the factory calibration accuracy to your network analyzer. They are characterized by Agilent using a precision calibration technique (similar in accuracy to TRL) that is traceable to the National Institute of Standards and Technology (NIST). Each calibration module's unique S-parameter data is stored in the module's memory. During calibration, ECal uses this data to calculate the error terms for your network analyzer. All measurements on either insertable or non-insertable devices are traceable to NIST.

Faster calibration with a single connection

Unlike the traditional mechanical technique, ECal only requires one connection to perform a full one- to four-port calibration from the calibration module to the test ports.

By reducing the number of connections required for a calibration, you can

- calibrate faster, so you save time and make measurements sooner
- reduce the chance of operator error, for greater confidence in your calibrations
- reduce the wear on connectors, for lower repair costs on both the test port connectors and calibration standards

Network analyzer compatibility

The 85090 family of RF ECal modules provides calibration across the frequency range of the ENA and 8753 series of network analyzers. The N4690 family of microwave ECal modules provides calibrations through 67 GHz for PNA-L and PNA network analyzers. The N4430 family of four-port modules provide calibration for the ENA, PNA, and 4-port PNA-L, and any multipoint solutions.

Suggested ECal and network analyzer/firmware compatibility¹

Agilent VNA model number	ECal module model number	85097B Required
8753E/ES/ET ²	85090 Series	Y
8719D/ES/ET ^{2, 3}	N4690 Series	Y
8720D/ES/ET ^{2, 3}	N4690 Series	Y
8722D/ES/ET ^{2, 3}	N4690 Series	Y
ENA Series ⁴	N4430 Series, 85090 Series	N
ENA-L Series ⁵	N4430 Series, 85090 Series	N
PNA Series ⁶	N4430 Series, N4690 Series	N
PNA-L Series ⁷	N4430 Series, N4690 Series	N

1. For complete compatibility refer to the *ECal Reference Guide* (publication N4693-90001).
2. Analyzer firmware control available with firmware rev. 7.68.
3. N4690 series works with firmware revision 7.74 or higher. Please note: 8719, 8720, and 8722 have been discontinued.
4. ENA series consists of E5070/1.
5. ENA-L series consists of E5061/2.
6. The PNA Series Network Analyzers consists of E8361/2/3/4. Please note: RF PNA Series E8356/7/8, E8801/2/3 and N3381/2/3 have been discontinued.
7. PNA-L series consists of N5230.

ECal and Agilent Network Analyzer Configurations

PNA and ENA Series

ECal modules are controlled directly from the PNA and ENA Series network analyzers. No external PC is required. Simply connect the ECal module to the USB port on the network analyzer. You can control your calibration from the front panel keys of the PNA Series or automatically by your user program.



Calibration configuration using the PNA series

8719, 8720, 8722 and 8753 product families

ECal modules are controlled manually or automatically via the 85097B interface kit. The 85097B consists of an interface unit and a power supply.

The interface module is the interface between the parallel port on your VNA, the parallel port of the ECal module and the external power supply.

Firmware revisions of 7.68 or higher in the 8753 and 8720 families allow for VNA control of ECal modules. The 85097B interface module, with the analyzer's internal firmware control, provides digital control and supplies power to one or two ECal modules. Calibration control is available via the front panel keys or from a user program. Firmware revision 7.74 and adapter cable (8121-1047) are required for the N4690 Series. The adapter cable can be ordered as an option with the 85097B.

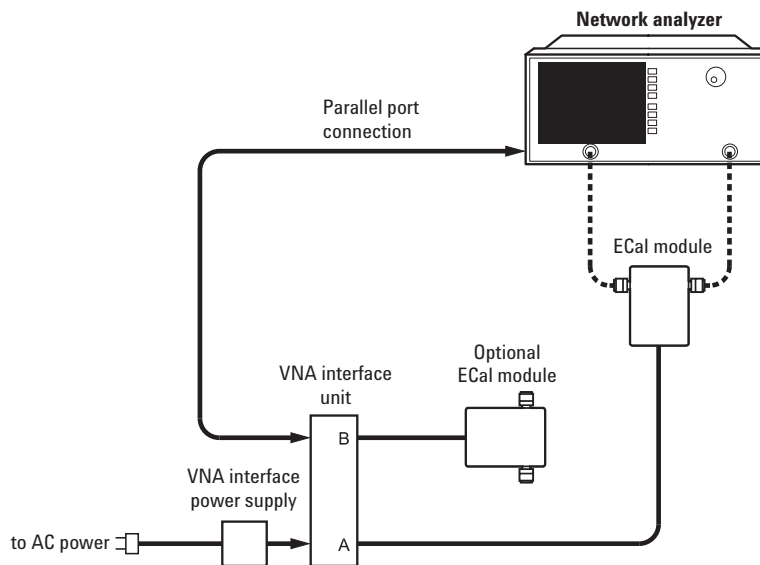

Calibration configuration using the 85097B VNA interface kit

Simple Non-insertable Calibrations

Most common RF and microwave components have non-insertable connectors; for example, devices with female connectors on both ports. These devices require an adapter removal calibration, which adds an uncertainty factor to the measurement. Most modern vector network analyzers use an adapter removal technique, which compensates for adapter-caused errors.

The simplest and fastest non-insertable calibration method uses an ECal module with connectors that match your device, and the same calibration method as insertable devices. Simply order your ECal module with connectors that match your device under test:

- Option 00M, male connectors on both ports
- Option 00F, female connectors on both ports.
- Option MOF with one male and one female connector.

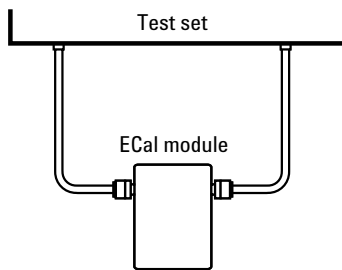

Perform adapter removal calibrations faster

Some analyzers, such as later versions of the 8753 and 8720, offer adapter removal calibration for non-insertable and mixed connector measurement capability. Since this method requires two full two-port calibrations, it is often time consuming and prone to operator errors. Using ECal to perform the two-port calibrations addresses both of these concerns by reducing the calibration time and the number of connections, simplifying the overall adapter removal process.

Perform a User-characterization

Normally, when you perform a calibration with an ECal module, the error terms for a calibration are computed using the factory characterization (data) stored in the module. User-characterization allows you to change the characterization of the module in two ways:

- *Change the connector configuration:* allows you to add an adapter or fixture to the test port of the module and embed the effects into the characterization of the module. The result of the new characterization extends the reference plane from one or more of the module's test ports to those on the adapter (or fixture).
- *Modify the state settings:* allows you to specify the number of data points (1601 maximum) or other stimulus settings the module uses to perform a calibration.

When you perform a user-characterization, the factory characterization data remains stored in the module's memory. At calibration, you can select the factory characterization or any of the user-defined characterizations stored in the module. The module can store up to five user-defined characterizations (in addition to the factory characterization data).

User-characterization is available with PNA and ENA Series Network Analyzers.

Power limits

Maximum input power	
8509x	+ 20 dBm
N469x	+10 dBm
Minimum input power	-45 dBm

Electrical characteristic corrected performance³ (Residual e-terms)

2-port ECal modules

Type-F

85099C (RF)¹

Frequency range	300 kHz to 300 MHz	300 MHz to 1 GHz	1 to 3 GHz
Directivity (dB)	50	48	43
Source match (dB)	48	45	38
Reflection tracking (\pm dB)	0.03	0.07	0.15
Transmission tracking (\pm dB)	0.08	0.10	0.17
Load match (dB)	43	41	39

85099C (RF)²

Frequency range	300 kHz to 300 MHz	300 MHz to 1 GHz	1 to 3 GHz
Directivity (dB)	48	43	32
Source match (dB)	46	41	26
Reflection tracking (\pm dB)	0.06	0.09	0.35
Transmission tracking (\pm dB)	0.08	0.12	0.35
Load match (dB)	43	40	29

1. When mated with male connectors with a 0.77 mm (0.030 in) to 0.86 mm (0.034 in) pin diameter
2. Typical values when mated with male connectors with a 0.56 mm (0.022 in) to 1.07 mm (0.042 in) pin diameter
3. Except 10 MHz to 45 MHz on N469x modules, which are typical

Type-N (50 ohms)

85092C (RF)

Frequency range	300 kHz to 1 GHz	1 to 3 GHz	3 to 6 GHz	6 to 9 GHz
Directivity (dB)	52	54	52	47
Source match (dB)	45	44	41	36
Reflection tracking (\pm dB)	0.04	0.04	0.06	0.07
Transmission tracking (\pm dB)	0.04	0.04	0.07	0.14
Load match (dB)	47	47	44	39

N4690B (microwave)

Frequency range	300 kHz to 10 MHz	10 to 500 MHz	500 MHz to 2 GHz	2 to 10 GHz	10 to 18 GHz
Directivity (dB)	40	45	48	46	42
Source match (dB)	35	40	43	40	35
Reflection tracking (\pm dB)	0.07	0.05	0.03	0.03	0.05
Transmission tracking (\pm dB)	0.12	0.08	0.07	0.07	0.12
Load match (dB)	29	35	42	41	38

Type-N (75 ohms)

85096C (RF)

Frequency range	300 kHz to 300 MHz	300 MHz to 1 GHz	1 to 3 GHz
Directivity (dB)	50	48	43
Source match (dB)	48	45	38
Reflection tracking (\pm dB)	0.03	0.06	0.10
Transmission tracking (\pm dB)	0.08	0.09	0.16
Load match (dB)	43	41	39

3.5 mm¹

85093C (RF)

Frequency range	300 kHz to 1 GHz	1 to 3 GHz	3 to 6 GHz	6 to 9 GHz
Directivity (dB)	52	52	50.5	47
Source match (dB)	44	44	39	34
Reflection tracking (\pm dB)	0.03	0.03	0.05	0.07
Transmission tracking (\pm dB)	0.04	0.05	0.07	0.12
Load match (dB)	47	47	44	40

N4691B (microwave)

Frequency range	300 kHz to 10 MHz	10 to 500 MHz	500 MHz to 2 GHz	2 to 10 GHz	10 to 20 GHz	20 to 26.5 GHz
Directivity (dB)	41	46	56	54	48	44
Source match (dB)	36	41	47	45	44	40
Reflection tracking (\pm dB)	0.06	0.05	0.02	0.03	0.04	0.05
Transmission tracking (\pm dB)	0.11	0.07	0.05	0.07	0.1	0.12
Load match (dB)	31	37	45	49	45	40

1. 3.5 mm modules have precision slotless connectors that guarantee the best calibration accuracy is transferred to your system.

7 mm

85091C (RF)

Frequency range	300 kHz to 1 GHz	1 to 3 GHz	3 to 6 GHz	6 to 9 GHz
Directivity (dB)	52	56	55	45
Source match (dB)	45	44	41	34
Reflection tracking (\pm dB)	0.04	0.04	0.07	0.10
Transmission tracking (\pm dB)	0.06	0.06	0.13	0.23
Load match (dB)	47	47	46	39

N4696B (microwave)

Frequency range (GHz)	300 kHz to 10 MHz	10 to 500 MHz	500 MHz to 2 GHz	2 to 10 GHz	10 to 18 GHz
Directivity (dB)	40	46	45	50	42
Source match (dB)	35	40	40	42	36
Reflection tracking (\pm dB)	0.07	0.05	0.03	0.03	0.05
Transmission tracking (\pm dB)	0.11	0.07	0.04	0.07	0.1
Load match (dB)	30	36	40	45	39

7-16

85098C (RF)

Frequency range	300 kHz to 1 GHz	1 to 3 GHz	3 to 6 GHz	6 to 7.5 GHz
Directivity (dB)	47	50	46	45
Source match (dB)	43	43	38	37
Reflection tracking (\pm dB)	0.03	0.03	0.05	0.06
Transmission tracking (\pm dB)	0.05	0.06	0.08	0.10
Load match (dB)	42	43	41	38

2.92 mm

N4692A (microwave)

Frequency range (GHz)	10 to 45 MHz, typical	45 MHz to 2 GHz	2 to 20 MHz	20 to 30 GHz	30 to 40 GHz
Directivity (dB)	35	45	43	39	38
Source match (dB)	30	36	35	30	29
Reflection tracking (\pm dB)	0.10	0.08	0.08	0.10	0.10
Transmission tracking (\pm dB)	0.10	0.14	0.14	0.20	0.25
Load match (dB)	27	36	37	33	33

2.4 mm

N4693A (microwave)

Frequency range (GHz)	10 to 45 MHz, typical	45 MHz to 2 GHz	2 to 10 MHz	10 to 20 GHz	20 to 40 GHz	40 to 50 GHz
Directivity (dB)	32	55	49	45	43	41
Source match (dB)	25	46	42	37	35	30
Reflection tracking (\pm dB)	0.05	0.03	0.04	0.05	0.06	0.08
Transmission tracking (\pm dB)	0.10	0.06	0.08	0.11	0.13	0.17
Load match (dB)	24	45	42	40	38	36

1.85 mm

N4694A (microwave)

Frequency range (GHz)	10 to 45 MHz, typical	45 MHz to 2 GHz	2 to 20 GHz	20 to 30 GHz	30 to 40 GHz	40 to 50 GHz	50 to 60 GHz	60 to 67 GHz
Directivity (dB)	33	50	50	46	44	42	41	38
Source match (dB)	25	38	39	35	34	33	30	27
Reflection tracking (\pm dB)	0.05	0.04	0.04	0.05	0.06	0.07	0.08	0.09
Transmission tracking (\pm dB)	0.15	0.07	0.1	0.11	0.13	0.15	0.19	0.25
Load match (dB)	25	41	44	42	40	38	36	32

4-port modules

Type-N (50 ohms)

N4431B (RF), option 020

Frequency range	300 kHz to 1 GHz	1 to 3 GHz	3 to 6 GHz	6 to 8 GHz	8 to 9 GHz	9 to 13.5 GHz
Thru paths AB, CD, AD, BC						
Directivity (dB)	55	52	47	44	42	40
Source match (dB)	47	43	42	40	39	31
Reflection tracking (\pm dB)	0.03	0.04	0.04	0.05	0.06	0.11
Transmission tracking (\pm dB)	0.07	0.10	0.14	0.20	0.22	0.35
Load match (dB)	47	45	40	38	35	26
Thru paths AC, BD						
Directivity (dB)	55	52	47	44	42	40
Source match (dB)	47	43	42	40	39	31
Reflection tracking (\pm dB)	0.03	0.04	0.04	0.05	0.06	0.11
Transmission tracking (\pm dB)	0.07	0.09	0.13	0.15	0.16	0.32
Load match (dB)	47	45	40	38	36	28

3.5 mm

N4431B (RF), option 010

Frequency range	300 kHz to 1 GHz	1 to 3 GHz	3 to 6 GHz	6 to 8 GHz	8 to 9 GHz	9 to 13.5 GHz
Thru paths AB, CD, AD, BC						
Directivity (dB)	57	55	52	50	47	40
Source match (dB)	50	47	45	44	43	32
Reflection tracking (\pm dB)	0.03	0.03	0.04	0.04	0.05	0.1
Transmission tracking (\pm dB)	0.06	0.09	0.12	0.14	0.20	0.33
Load match (dB)	47	46	45	44	42	28
Thru paths AC, BD						
Directivity (dB)	57	55	52	50	47	40
Source match (dB)	50	47	45	44	43	32
Reflection tracking (\pm dB)	0.03	0.03	0.04	0.04	0.05	0.1
Transmission tracking (\pm dB)	0.06	0.08	0.10	0.12	0.14	0.3
Load match (dB)	47	46	45	45	43	29

Type-N (50 ohms) N4432A

The characteristic performance in the following table applies to N4432A Option 020 (3.5 mm female connectors on all ports).

Characteristic performance for N4432A Option 020

Frequency range	300 kHz to 1 GHz	10 MHz to 5 GHz	5 to 9 GHz	9 to 13.5 GHz	13.5 to 18 GHz
Parameter					
Directivity (dB)	45	52	47	41	42
Source match (dB)	35	41	37	34	34
Reflection tracking (\pm dB)	0.1	0.06	0.1	0.15	0.14
Transmission tracking (\pm dB) ¹	0.082	0.046	0.062	0.089	0.084
Load match (dB) ¹	39	45	40	36	37

3.5 mm N4433A

The characteristic performance in the following table applies to N4433A Option 010 (3.5 mm female connectors on all ports).

Characteristic performance for N4433A Option 010

Frequency range	300 kHz to 1 GHz	10 MHz to 5 GHz	5 to 9 GHz	9 to 13.5 GHz	13.5 to 20 GHz
Parameter					
Directivity (dB)	45	52	47	45	45
Source match (dB)	36	42	39	37	31
Reflection tracking (\pm dB)	0.1	0.06	0.09	0.10	0.18
Transmission tracking (\pm dB) ¹	0.078	0.045	0.057	0.069	0.160
Load match (dB) ¹	39	45	41	39	35

1. Values based on using the PNA Network Analyzer N5230A Option 240 or 245

Ordering information

Select an ECal module based on the connector type required and the frequency range of your vector network analyzer (refer to table below).

Notes:

1. Order the 85097B interface module if you will be using ECal with your 8719, 8720, 8722 or 8753. (Please reference the ECal and network analyzer/firmware compatibility table on page 3.) The 85097B consists of an interface module and a power supply.
2. When using the N469x ECal products with the 8720 or 8753 network analyzer families, an adapter cable (8121-1047) is needed. This adapter cable is orderable as an option with the 85097B.

ECal modules and available options

2-port

Connector Type	Frequency range	ECal module model number	Available options
Type-F	300 kHz to 3 GHz	85099C	00A, 00F, 00M, UK6, M0F
Type-N 50 ohms	300 kHz to 9 GHz	85092C	00A, 00F, 00M, UK6, 1A7, A6J, M0F, mixed-connectors
Type-N 50 ohms	300 kHz to 18 GHz	N4690B	00A, 00F, 00M, UK6, 1A7, A6J, M0F
Type-N 75 ohms	300 kHz to 3 GHz	85096C	00A, 00F, 00M, UK6, M0F
3.5 mm	300 kHz to 9 GHz	85093C	00A, 00F, 00M, UK6, 1A7, A6J, M0F mixed connectors
3.5 mm	300 kHz to 26.5 GHz	N4691B	00A, 00F, 00M, UK6, 1A7, A6J, M0F
7 mm	300 kHz to 9 GHz	85091C	UK6, 1A7, A6J
7 mm	300 kHz to 18 GHz	N4696B	UK6, 1A7, A6J
7-16	300 kHz to 7.5 GHz	85098C	00A, 00F, 00M, UK6, M0F, mixed-connectors
2.92 mm	10 MHz to 40 GHz	N4692A	00A, 00F, 00M, UK6, 1A7, A6J, M0F
2.4 mm	10 MHz to 50 GHz	N4693A	00A, 00F, 00M, UK6, 1A7, A6J, M0F
1.85 mm	10 MHz to 67 GHz	N4694A	00A, 00F, 00M, UK6, 1A7, A6J, M0F

4-port

Connector Type	Frequency range	ECal module model number	Available options
3.5 mm or Type-N 50 ohms	300 kHz to 13.5 GHz	N4431B	010, 020, UK6, 1A7, A6J, mixed-connectors
Type-N 50 ohms	300 kHz to 18 GHz	N4432A	020, mixed-connectors
3.5 mm	300 kHz to 20 GHz	N4433A	010

Options

Option	Description
00F	Replace f-m connectors on ECal module(s) with f-f connectors
00M	Replace f-m connectors on ECal module(s) with m-m connectors
00A	Adds male-to-male and female-to-female adapters (also adds a 5/16" 90 N-cm (8 in-lb) torque wrench to 3.5 mm modules)
1A7	ISO 17025 compliant calibration
A6J	ANSI Z540 compliant calibration
UK6	Commercial calibration certificate with measured data
M0F	f-m connectors on ECal module(s)
010	Four female, 3.5 mm connectors
020	Four female, Type-N 50 ohm connectors

Mixed-connector options

2-port (85092C/3C/8C ECal modules only)

Model number	Port A option			Port B option					
	Type	(f)	(m)	Type	(f)	(m)	Type	(f)	(m)
85092C	Type-N 50 ohm	103	104	3.5 mm	201	202	7-16 ¹	205	206
85093C	3.5 mm	101	102	Type-N 50 ohm	203	204	7-16 ¹	205	206
85098C	7-16 ¹	105	106	3.5 mm	201	202	Type-N 50 ohm	203	204

4-port (N4431B ECal module only)

Connector type	Port A option	Port B option	Port C option	Port D option
3.5 mm (f)	101	201	301	401
3.5 mm (m)	102	202	302	402
Type-N 50 ohm (f)	103	203	303	403
Type-N 50 ohm (m)	104	204	304	404
7-16 (f) ¹	105	205	305	405
7-16 (m) ¹	106	206	306	406

4-port (N4432A ECal module only)

Connector type	Port A option	Port B option	Port C option	Port D option
3.5 mm (f)	101	201	301	401
3.5 mm (m)	102	202	302	402
Type-N 50 ohm (f)	103	203	303	403
Type-N 50 ohm (m)	104	204	304	404

1. Limits ECal module high frequency to 7.5 GHz.

Web Resources

Visit our Web sites, for additional product information and literature.

Electronic calibration (ECal):
www.agilent.com/find/ecal

PNA Series network analyzers:
www.agilent.com/find/pna

Test and measurement accessories:
www.agilent.com/find/accessories



Agilent Email Updates

www.agilent.com/find/emailupdates
Get the latest information on the products and applications you select.



Agilent Direct

www.agilent.com/find/agilentdirect
Quickly choose and use your test equipment solutions with confidence.



Agilent Open

www.agilent.com/find/open
Agilent Open simplifies the process of connecting and programming test systems to help engineers design, validate and manufacture electronic products. Agilent offers open connectivity for a broad range of system-ready instruments, open industry software, PC-standard I/O and global support, which are combined to more easily integrate test system development.

www.agilent.com

Agilent Technologies' Test and Measurement Support, Services, and Assistance

Agilent Technologies aims to maximize the value you receive, while minimizing your risk and problems. We strive to ensure that you get the test and measurement capabilities you paid for and obtain the support you need. Our extensive support resources and services can help you choose the right Agilent products for your applications and apply them successfully. Every instrument and system we sell has a global warranty. Two concepts underlie Agilent's overall support policy: "Our Promise" and "Your Advantage."

Our Promise

Our Promise means your Agilent test and measurement equipment will meet its advertised performance and functionality. When you are choosing new equipment, we will help you with product information, including realistic performance specifications and practical recommendations from experienced test engineers. When you receive your new Agilent equipment, we can help verify that it works properly and help with initial product operation.

Your Advantage

Your Advantage means that Agilent offers a wide range of additional expert test and measurement services, which you can purchase according to your unique technical and business needs. Solve problems efficiently and gain a competitive edge by contracting with us for calibration, extra-cost upgrades, out-of-warranty repairs, and onsite education and training, as well as design, system integration, project management, and other professional engineering services. Experienced Agilent engineers and technicians worldwide can help you maximize your productivity, optimize the return on investment of your Agilent instruments and systems, and obtain dependable measurement accuracy for the life of those products.

For more information on Agilent Technologies' products, applications or services, please contact your local Agilent office.

Phone or Fax

United States:

(tel) 800 829 4444
(fax) 800 829 4433

Canada:

(tel) 877 894 4414
(fax) 800 746 4866

China:

(tel) 800 810 0189
(fax) 800 820 2816

Europe:

(tel) 31 20 547 2111

Japan:

(tel) (81) 426 56 7832
(fax) (81) 426 56 7840

Korea:

(tel) (080) 769 0800
(fax) (080) 769 0900

Latin America:

(tel) (305) 269 7500

Taiwan:

(tel) 0800 047 866
(fax) 0800 286 331

Other Asia Pacific Countries:

(tel) (65) 6375 8100

(fax) (65) 6755 0042

Email: tm_ap@agilent.com

Contacts revised: 09/26/05

The complete list is available at:
www.agilent.com/find/contactus

Product specifications and descriptions in this document subject to change without notice.

© Agilent Technologies, Inc. 2002 - 2006
Printed in USA, February 22, 2006
5963-3743E

Windows® and Windows NT® are U.S. registered trademarks of Microsoft Corp.



Agilent Technologies