

User's and Service Guide

Agilent Technologies 85033E 3.5 mm Calibration Kit



Agilent Part Number: 85033-90028

Printed in USA

Print Date: August 2010

Supersedes: April 2010

Copyright © 2000–2002, 2004, 2008-2010 Agilent Technologies, Inc. All rights reserved.

Documentation Warranty

THE MATERIAL CONTAINED IN THIS DOCUMENT IS PROVIDED "AS IS," AND IS SUBJECT TO BEING CHANGED, WITHOUT NOTICE, IN FUTURE EDITIONS. FURTHER, TO THE MAXIMUM EXTENT PERMITTED BY APPLICABLE LAW, AGILENT DISCLAIMS ALL WARRANTIES, EITHER EXPRESS OR IMPLIED WITH REGARD TO THIS MANUAL AND ANY INFORMATION CONTAINED HEREIN, INCLUDING BUT NOT LIMITED TO THE IMPLIED WARRANTIES OF MERCHANTABILITY AND FITNESS FOR A PARTICULAR PURPOSE. AGILENT SHALL NOT BE LIABLE FOR ERRORS OR FOR INCIDENTAL OR CONSEQUENTIAL DAMAGES IN CONNECTION WITH THE FURNISHING, USE, OR PERFORMANCE OF THIS DOCUMENT OR ANY INFORMATION CONTAINED HEREIN. SHOULD AGILENT AND THE USER HAVE A SEPARATE WRITTEN AGREEMENT WITH WARRANTY TERMS COVERING THE MATERIAL IN THIS DOCUMENT THAT CONFLICT WITH THESE TERMS, THE WARRANTY TERMS IN THE SEPARATE AGREEMENT WILL CONTROL.

DFARS/Restricted Rights Notice

If software is for use in the performance of a U.S. Government prime contract or subcontract, Software is delivered and licensed as "Commercial computer software" as defined in DFAR 252.227-7014 (June 1995), or as a "commercial item" as defined in FAR 2.101(a) or as "Restricted computer software" as defined in FAR 52.227-19 (June 1987) or any equivalent agency regulation or contract clause. Use, duplication or disclosure of Software is subject to Agilent Technologies' standard commercial license terms, and non-DOD Departments and Agencies of the U.S. Government will receive no greater than Restricted Rights as defined in FAR 52.227-19(c)(1-2) (June 1987). U.S. Government users will receive no greater than Limited Rights as defined in FAR 52.227-14 (June 1987) or DFAR 252.227-7015 (b)(2) (November 1995), as applicable in any technical data.

Printing Copies of Documentation from the Web

To print copies of documentation from the Web, download the PDF file from the Agilent web site:

- Go to www.agilent.com.
- Enter the product model number in the Search function and click **Search**.
- Click on the **Manuals** hyperlink.
- Open the PDF of your choice and print the document.

1. General Information

Calibration Kit Overview	1-2
Kit Contents	1-2
Broadband Loads	1-2
Offset Opens and Shorts	1-2
Open-Short-Load Holders	1-2
Calibration Definitions	1-3
Options	1-4
Equipment Required but Not Supplied	1-4
Incoming Inspection	1-5
Recording the Device Serial Numbers	1-6
Precision Slotless Connectors	1-7
Clarifying the Terminology of a Connector Interface	1-8
Preventive Maintenance	1-8
When to Calibrate	1-9

2. Specifications

Environmental Requirements	2-2
Temperature—What to Watch Out For	2-2
Mechanical Characteristics	2-3
Pin Depth	2-3
Electrical Specifications	2-5
Supplemental Characteristics	2-6
Certification	2-6

3. Use, Maintenance, and Care of the Devices

Electrostatic Discharge	3-2
Visual Inspection	3-3
Look for Obvious Defects and Damage First	3-3
What Causes Connector Wear?	3-3
Inspect the Mating Plane Surfaces	3-3
Inspect Female Connectors	3-4
Cleaning Connectors	3-5
Gaging Connectors	3-7
Connector Gage Accuracy	3-7
When to Gage Connectors	3-8
Gaging Procedures	3-8
Gaging Male 3.5 mm Connectors	3-8
Gaging Female 3.5 mm Connectors	3-11
Connections	3-13
How to Make a Connection	3-13
Preliminary Connection	3-13
Final Connection Using a Torque Wrench	3-14
How to Separate a Connection	3-15
Handling and Storage	3-16

4. Performance Verification

Introduction	4-2
------------------------	-----

How Agilent Verifies the Devices in This Kit	4-2
Recertification	4-3
How Often to Recertify.	4-3
Where to Send a Kit for Recertification	4-3
5. Troubleshooting	
Troubleshooting Process	5-2
Where to Look for More Information	5-3
Returning a Kit or Device to Agilent	5-4
Contacting Agilent.	5-4
6. Replaceable Parts	
Introduction	6-2
A. Standard Definitions	
Class Assignments and Standard Definitions Values are Available on the Web.	A-2

1 General Information

Calibration Kit Overview

The Agilent 85033E 3.5 mm calibration kit is used to calibrate Agilent network analyzers for measurements of components with 3.5 mm connectors up to 9 GHz.

Kit Contents

Use the Contents List in the shipping container to verify the completeness of your shipment. Although this list is the most accurate, you can also use the illustration in Chapter 7 to verify the items in your shipment. If your shipment is not complete, contact Agilent Technologies - refer to [“Contacting Agilent” on page 5-4](#).

Refer to [Table 6-1 on page 6-4](#) for part numbers of kit contents.

Broadband Loads

The broadband loads are metrology-grade, 50 ohm terminations which have been optimized for performance up to 9 GHz. The rugged internal structure provides for highly repeatable connections. A distributed resistive element on sapphire provides excellent stability and return loss.

Offset Opens and Shorts

The offset opens and shorts are built from parts which are machined to the current state-of-the-art in precision machining. The offset short's inner conductors have a one-piece construction, common with the shorting plane. The construction provides for extremely repeatable connections. The offset opens have inner conductors which are supported by a strong, low-dielectric-constant plastic to minimize compensation values. Both the opens and shorts are constructed so that the pin depth can be controlled very tightly, thereby minimizing phase errors. The lengths of the offsets in the opens and shorts are designed so that the difference in phase of their reflection coefficients is approximately 180 degrees at all frequencies.

Open-Short-Load Holders

The open-short-load (OSL) holders are included for your convenience. The OSL holders allow you to keep all of the calibration devices in two handy assemblies. Load each OSL holder with calibration devices of the same connector sex so that you can perform a calibration with just one assembly. Use the 2.5 mm hex key included with this kit to secure the calibration devices in the holders. See [Figure 1-1 on page 1-3](#).

Figure 1-1 Open-Short-Load Holder

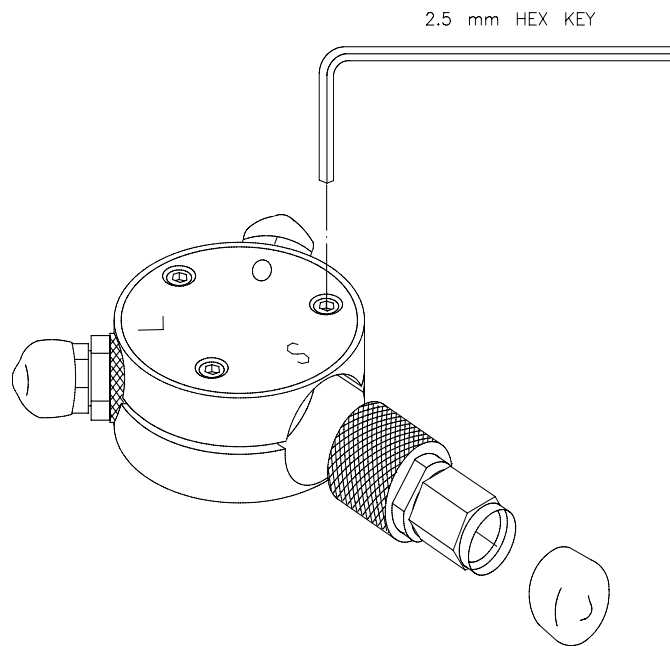

wj610d

Calibration Definitions

The calibration kit must be selected and the calibration definitions for the devices in the kit installed in the network analyzer prior to performing a calibration.

The calibration definitions can be:

- resident within the analyzer
- downloaded from the Web at <http://na.tm.agilent.com/pna/caldefs/stddefs.html>
- manually entered from the front panel

Refer to your network analyzer user's guide or embedded Help for instructions on manually entering calibration definitions, selecting the calibration kit, and performing a calibration.

NOTE The 8510 network analyzer is no longer being sold or supported by Agilent. However, you can download the 8510 class assignments and standard definitions from Agilent's Calibration Kit Definitions Web page at www.na.tm.agilent.com/pna/caldefs/stddefs.html

Options

There are several adapter options available for the 85033E. Refer to [Table 6-2 on page 6-5](#). Also, there are calibration certificate options available. Contact Agilent for more information. See [“Contacting Agilent” on page 5-4](#) for contact information.

Equipment Required but Not Supplied

Gages, electrostatic discharge (ESD) protection devices, and various connector cleaning supplies are *not* included with this calibration kit. Gage sets are required for measuring the connector pin depth. Refer to [Table 6-3 on page 6-5](#) for ordering information.

Incoming Inspection

Check for damage. The foam-lined storage case provides protection during shipping. Verify that this case and its contents are not damaged.

If the case or any device appears damaged, or if the shipment is incomplete, contact Agilent Technologies. See [“Contacting Agilent” on page 5-4](#). Agilent will arrange for repair or replacement of incomplete or damaged shipments without waiting for a settlement from the transportation company.

When you send the kit or device to Agilent, include a service tag (found near the end of this manual) with the following information:

- your company name and address
- the name of a technical contact person within your company, and the person's complete phone number
- the model number and serial number of the kit
- the part number and serial number of the device
- the type of service required
- a *detailed* description of the problem

Recording the Device Serial Numbers

In addition to the kit serial number, the devices in this kit are individually serialized (serial numbers are labeled onto the body of each device). Record these serial numbers in [Table 1-1](#). This can help you avoid confusing the devices in this kit with similar devices from other kits.

The adapters included in the kit are for measurement convenience only and are not serialized.

Table 1-1 Kit and Device Serial Number Record

Device	Serial Number
Calibration kit	_____
-m- Broadband Load	_____
-f- Broadband Load	_____
-m- Open	_____
-f- Open	_____
-m- Short	_____
-f- Short	_____

Precision Slotless Connectors

The female 3.5 mm connectors in this calibration kit are metrology-grade, precision slotless connectors (PSC). A characteristic of metrology-grade connectors is direct traceability to national measurement standards through their well-defined mechanical dimensions.

Conventional female center conductors are slotted. When mated, the female center conductor is flared by the male pin. Because physical dimensions determine connector impedance, electrical characteristics of the female connector (and connection pair) are dependent upon the mechanical dimensions of the male pin. While connectors are used in pairs, their male and female halves are always specified separately as part of a standard, instrument, or device under test. Because of these facts, making precision measurements with the conventional slotted connector is very difficult, and establishing a direct traceability path to primary dimensional standards is nearly impossible.

The precision slotless connector was developed to eliminate these problems. All PSCs are female. A PSC incorporates a center conductor with a solid cylindrical shell that defines the outside diameter of the female center pin. Its outside diameter and, therefore, the impedance in its region does not change. The inner part provides an internal contact that flexes to accept the allowed range of male pin diameters.

The calibration of a network analyzer having a conventional slotted female connector on the test port remains valid only when the device under test and all calibration standards have identical male pin diameters. For this reason PSC test port adapters are supplied in most calibration kits.

Precision slotless connectors have the following characteristics:

- There is no loss of traceable calibration on test ports when the male pin diameter of the connector on the device under test is different from the male pin diameter of the calibration standard.
- The female PSC and its mating male connector can be measured and specified separately as part of the device either is attached to.
- All female connectors can have a known, stable impedance based only on the diameters of their inner and outer conductors.
- Female calibration standards can be fully specified. Their specifications and traceability are unaffected by the diameter of the male mating pin.
- A fully traceable performance verification is made using a precision 50 ohm airline having a PSC.
- Measurement repeatability is enhanced due to non-changing connector characteristics with various pin diameters.

With PSCs on test ports and standards, the percentage of accuracy achieved when measuring at 50 dB return loss levels is comparable to using conventional slotted connectors measuring devices having only 30 dB return loss. This represents an accuracy improvement of about 10 times.

Clarifying the Terminology of a Connector Interface

In this document and in the prompts of the PNA calibration wizard, the sex of cable connectors and adapters is referred to in terms of the center conductor. For example, a connector or device designated as 1.85 mm –f– has a 1.85 mm female center conductor.

8510-series, 872x, and 875x ONLY: In contrast, during a measurement calibration, the network analyzer softkey menus label a 1.85 mm calibration device with reference to the sex of the analyzer’s test port connector—not the calibration device connector. For example, the label `SHORT (F)` refers to the short that is to be connected to the female test port. This will be a male short from the calibration kit.

Table 1-2 Clarifying the Terminology of Connectors: Examples

Terminology	Meaning
Short –f–	Female short (female center conductor)
Short (f)	Male short (male center conductor) to be connected to female port

A connector gage is referred to in terms of the connector that it measures. For instance, a male connector gage has a female connector on the gage so that it can measure male devices.

Preventive Maintenance

The best techniques for maintaining the integrity of the devices in the kit include:

- routine visual inspection
- cleaning
- proper gaging
- proper connection techniques

All of these are described in [Chapter 3, “Use, Maintenance, and Care of the Devices.”](#) Failure to detect and remove dirt or metallic particles on a mating plane surface can degrade repeatability and accuracy and can damage any connector mated to it. Improper connections, resulting from pin depth values being out of the observed limits (see [Table 2-3 on page 2-4](#)) or from bad connection techniques, can also damage these devices.

When to Calibrate

A network analyzer calibration remains valid as long as the changes in the systematic error are insignificant. This means that changes to the uncorrected leakages (directivity and isolation), mismatches (source match and load match), and frequency response of the system are small (<10%) relative to accuracy specifications.

Change in the environment (especially temperature) between calibration and measurement is the major cause in calibration accuracy degradation. The major effect is a change in the physical length of external and internal cables. Other important causes are dirty and damaged test port connectors and calibration standards. If the connectors become dirty or damaged, measurement repeatability and accuracy is affected.

Fortunately, it is relatively easy to evaluate the general validity of the calibration. To test repeatability, remeasure one of the calibration standards. If you can not obtain repeatable measurements from your calibration standards, maintenance needs to be performed on the test port connectors, cables and calibration standards. Also, maintain at least one sample of the device under test or some known device as your reference device. A verification kit may be used for this purpose. After calibration, measure the reference device and note its responses. Periodically remeasure the device and note any changes in its corrected response which can be attributed to the test system. With experience you will be able to see changes in the reference responses that indicate a need to perform the measurement calibration again.

2 Specifications

Environmental Requirements

Table 2-1 Environmental Requirements

Parameter	Limits
Temperature	
Operating ^a	+15 °C to +35 °C
Storage	–40 °C to +75 °C
Error-corrected range ^b	± 1 °C of measurement calibration temperature
Relative humidity	Type tested, 0% to 95%, 40 °C (non-condensing)

- a. The temperature range over which the calibration standards maintain conformance to their specifications.
- b. The allowable network analyzer ambient temperature drift during measurement calibration and during measurements when the network analyzer error correction is turned on. Also, the range over which the network analyzer maintains its specified performance while correction is turned on.

Temperature—What to Watch Out For

Changes in temperature can affect electrical characteristics. Therefore, the operating temperature is a critical factor in performance. During a measurement calibration, the temperature of the calibration devices must be stable and within the range shown in [Table 2-1](#).

IMPORTANT Avoid unnecessary handling of the devices during calibration because your fingers are a heat source.

Mechanical Characteristics

Mechanical characteristics such as center conductor protrusion and pin depth are *not* performance specifications. They are, however, important supplemental characteristics related to electrical performance. Agilent Technologies verifies the mechanical characteristics of the devices in this kit with special gaging processes and electrical testing. This ensures that the device connectors do not exhibit any center conductor protrusion or improper pin depth when the kit leaves the factory.

“Gaging Connectors” on page 3-7 explains how to use gages to determine if the kit devices have maintained their mechanical integrity. (Refer to Table 2-3 on page 2-4 for typical and observed pin depth limits.)

Table 2-2 Mechanical Characteristics

Dimension	Typical Value
Inside diameter of outer conductor	3.5 ±0.0025 mm
Outside diameter of center conductor	1.5199 ±0.002 mm
Pin depth ^a : -m- devices	0 to 0.0127 mm
Pin depth ^a : -f- devices	−0.0025 to −0.0254 mm

a. See Figure 2-1 on page 2-4.

Pin Depth

Pin depth is the distance the center conductor mating plane differs from being flush with the outer conductor mating plane. See Figure 2-1. The pin depth of a connector can be in one of two states: either protruding or recessed. **Protrusion** is the condition when the center conductor extends beyond the outer conductor mating plane, and will measure a positive value on the connector gage. **Recession** is when the center conductor is set back from the outer conductor mating plane and will measure negative.

The pin depth value of each calibration device in this kit is not specified, but is an important mechanical parameter. The electrical performance of the device depends, to some extent, on its pin depth. The electrical specifications for each device in this kit take into account the effect of pin depth on the device’s performance. Table 2-3 lists the typical pin depths and measurement uncertainties, and provides observed pin depth limits for the devices in the kit. If the pin depth of a device does not measure within the *observed* pin depth limits, it may be an indication that the device fails to meet electrical specifications. Refer to Figure 2-1 for a visual representation of proper pin depth (slightly recessed).

Figure 2-1 Connector Pin Depth

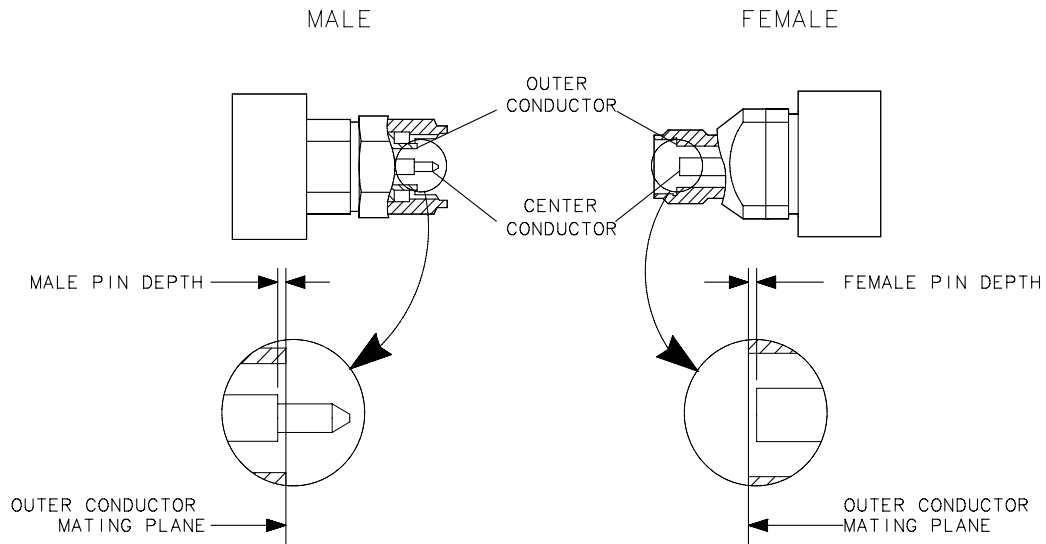

wj63d

Table 2-3 Pin Depth Limits

Device	Typical Pin Depth	Measurement Uncertainty ^a	Observed Pin Depth Limits ^b
Opens	0 to -0.0127 mm 0 to -0.0005 in.	+0.0064 to -0.0064 mm +0.00025 to -0.00025 in.	+0.0064 to -0.0191 mm +0.00025 to -0.00075 in.
Shorts	0 to -0.0127 mm 0 to -0.0005 in.	+0.0041 to -0.0041 mm +0.00016 to -0.00016 in.	+0.0041 to -0.0168 mm +0.0016 to -0.00066 in.
Fixed Loads	-0.0025 to -0.0254 mm -0.0001 to -0.001 in.	+0.0041 to -0.0041 mm +0.00016 to -0.00016 in.	+0.0016 to -0.02953 mm +0.00006 to -0.00116 in.
Adapters (3.5 mm end)	0 to -0.0762 mm 0 to -0.0030 in.	+0.0041 to -0.0041 mm +0.00016 to -0.00016 in.	+0.0041 to -0.0803 mm +0.00016 to -0.00316 in.
Adapters (APC-7 end)	0 to -0.0762 mm 0 to -0.0030 in.	+0.0038 to -0.0038 mm +0.00015 to -0.00015 in.	+0.0038 to -0.0800 mm +0.00015 to -0.00315 in.
Adapters (type-N end)	0 to -0.0508 mm 0 to -0.0020 in.	+0.0038 to -0.0038 mm +0.00015 to -0.00015 in.	+0.0038 to -0.0546 mm +0.00015 to -0.00215 in.

- a. Approximately +2 sigma to -2 sigma of gage uncertainty based on studies done at the factory according to recommended procedures.
- b. Observed pin depth limits are the range of observation limits seen on the gage reading due to measurement uncertainty. The depth could still be within specifications.

Electrical Specifications

The electrical specifications in [Table 2-4](#) apply to the devices in your calibration kit when connected with an Agilent precision interface.

Table 2-4 Electrical Specifications for 3.5 mm Devices

Device	Specification	Frequency (GHz)
Broadband Loads (-m- and -f-)	Return Loss ≥ 46 dB ($\rho \leq 0.005$)	DC to ≤ 2
	Return Loss ≥ 44 dB ($\rho \leq 0.006$)	>2 to ≤ 3
	Return Loss ≥ 38 dB ($\rho \leq 0.013$)	>3 to ≤ 9
Offset Opens ^a (-m- and -f-)	$\pm 0.55^\circ$ from Nominal	DC to ≤ 2
	$\pm 0.65^\circ$ from Nominal	>2 to ≤ 3
	$\pm 0.85^\circ$ from Nominal	>3 to ≤ 6
	$\pm 1.00^\circ$ from Nominal	>6 to ≤ 9
Offset Shorts ^a (-m- and -f-)	$\pm 0.48^\circ$ from Nominal	DC to ≤ 2
	$\pm 0.50^\circ$ from Nominal	>2 to ≤ 3
	$\pm 0.55^\circ$ from Nominal	>3 to ≤ 6
	$\pm 0.65^\circ$ from Nominal	>6 to ≤ 9

a. The specifications for the opens and shorts are given as allowed deviation from the nominal model as defined in the standard definitions.

Supplemental Characteristics

Supplemental characteristics are provided as additional information that may be helpful in applying the devices. These characteristics are typical of most devices but are not warranted. [Table 2-5](#) lists the typical characteristics of the adapters.

Table 2-5 Supplemental Electrical Characteristics of the Adaptors

Adapter	Return Loss, Typical	Frequency (GHz)
Option 100		
3.5 mm -f- to -f-	Return Loss ≥ 32 dB ($\rho \leq 0.025$)	DC to 26.5
Option 200		
3.5 mm -m- to -m-	Return Loss ≥ 32 dB ($\rho \leq 0.025$)	DC to 26.5
Option 300		
3.5 mm -m- to -f-	Return Loss ≥ 32 dB ($\rho \leq 0.025$)	DC to 26.5
Option 400		
Type-N -m- to 3.5 mm -m-	Return Loss ≥ 28 dB ($\rho \leq 0.040$)	DC to 18
Type-N -m- to 3.5 mm -f-	Return Loss ≥ 28 dB ($\rho \leq 0.040$)	DC to 18
Type-N -f- to 3.5 mm -f-	Return Loss ≥ 28 dB ($\rho \leq 0.040$)	DC to 18
Type-N -f- to 3.5 mm -m-	Return Loss ≥ 24 dB ($\rho \leq 0.060$)	DC to 18
Option 500		
3.5 mm -m- to APC-7	Return Loss ≥ 34 dB ($\rho \leq 0.020$)	DC to 18
3.5 mm -f- to APC-7	Return Loss ≥ 28 dB ($\rho \leq 0.040$)	DC to 18

Certification

Agilent Technologies certifies that this product met its published specifications at the time of shipment from the factory. Agilent further certifies that its calibration measurements are traceable to the United States National Institute of Standards and Technology (NIST) to the extent allowed by the institute’s calibration facility, and to the calibration facilities of other International Standards Organization members. See [“How Agilent Verifies the Devices in This Kit” on page 4-2](#) for more information.

3 Use, Maintenance, and Care of the Devices

Electrostatic Discharge

Protection against ESD (electrostatic discharge) is essential while connecting, inspecting, or cleaning connectors attached to a static-sensitive circuit (such as those found in test sets).

Static electricity can build up on your body and can easily damage sensitive internal circuit elements when discharged. Static discharges too small to be felt can cause permanent damage. Devices such as calibration components and devices under test (DUTs), can also carry an electrostatic charge. To prevent damage to the test set, components, and devices:

- *always* wear a grounded wrist strap having a 1 M Ω resistor in series with it when handling components and devices or when making connections to the test set.
- *always* use a grounded, conductive table mat while making connections.
- *always* wear a heel strap when working in an area with a conductive floor. If you are uncertain about the conductivity of your floor, wear a heel strap.
- *always* ground yourself before you clean, inspect, or make a connection to a static-sensitive device or test port. You can, for example, grasp the grounded outer shell of the test port or cable connector briefly.
- *always* ground the center conductor of a test cable before making a connection to the analyzer test port or other static-sensitive device. This can be done as follows:
 1. Connect a short (from your calibration kit) to one end of the cable to short the center conductor to the outer conductor.
 2. While wearing a grounded wrist strap, grasp the outer shell of the cable connector.
 3. Connect the other end of the cable to the test port.
 4. Remove the short from the cable.

Refer to [Chapter 6, “Replaceable Parts,”](#) for part numbers and instructions for ordering ESD protection devices.

Figure 3-1 ESD Protection Setup

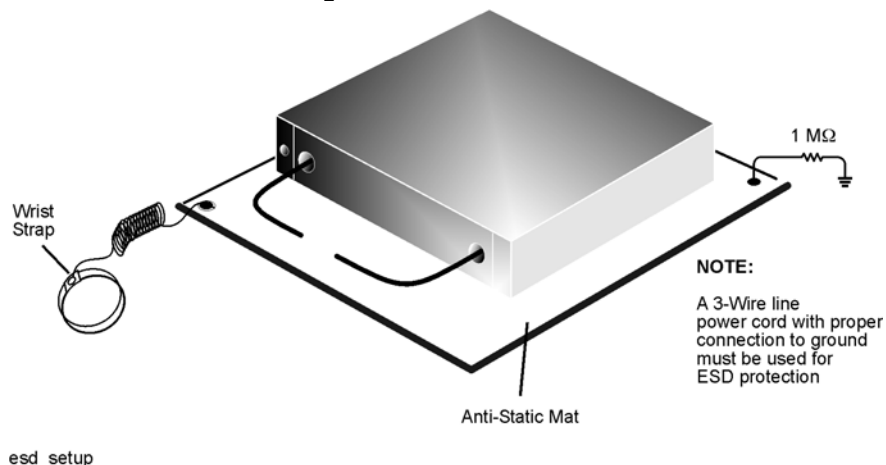

Visual Inspection

Visual inspection and, if necessary, cleaning should be done every time a connection is made. Metal particles from the connector threads may fall into the connector when it is disconnected. One connection made with a dirty or damaged connector can damage both connectors beyond repair.

Magnification is helpful when inspecting connectors, but it is not required and may actually be misleading. Defects and damage that cannot be seen without magnification generally have no effect on electrical or mechanical performance. Magnification is of great use in analyzing the nature and cause of damage and in cleaning connectors, but it is not required for inspection.

Look for Obvious Defects and Damage First

Examine the connectors first for obvious defects and damage: badly worn plating on the connector interface, deformed threads, or bent, broken, or misaligned center conductors.

What Causes Connector Wear?

Connector wear is caused by connecting and disconnecting the devices. The more use a connector gets, the faster it wears and degrades. The wear is greatly accelerated when connectors are not kept clean, or are not properly connected.

Connector wear eventually degrades the performance of the device. Calibration devices should have a long life if their use is on the order of a few times per week.

The test port connectors on the network analyzer test set may have many connections each day, and are therefore more subject to wear. It is recommended that an adapter be used as a test port saver to minimize the wear on the test set's connectors. Replace devices with worn connectors.

Inspect the Mating Plane Surfaces

Flat contact between the connectors at all points on their mating plane surfaces is required for a good connection. See [Figure 3-2](#). Look especially for deep scratches or dents, and for dirt and metal particles on the connector mating plane surfaces. Also look for signs of damage due to excessive or uneven wear or misalignment.

Light burnishing of the mating plane surfaces is normal, and is evident as light scratches or shallow circular marks distributed more or less uniformly over the mating plane surface. Other small defects and cosmetic imperfections are also normal. None of these affect electrical or mechanical performance. If a connector shows deep scratches or dents, particles clinging to the mating plane surfaces, or uneven wear, clean and inspect it again.

Figure 3-2 Mating Plane Surfaces

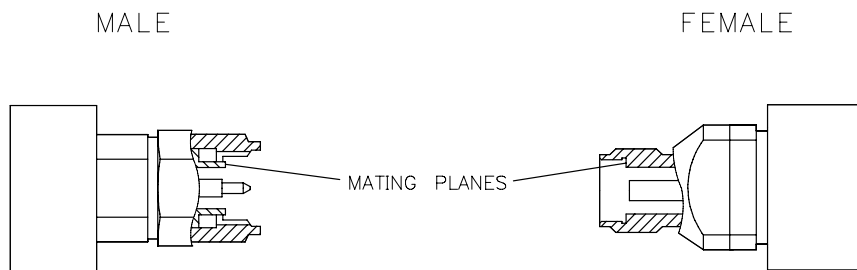

wj612d

Inspect Female Connectors

When using female connectors, pay special attention to the contact fingers in the female center conductor. These can be bent or broken, and damage to them is not always easy to see. A connector with damaged contact fingers will not make good electrical contact and must be replaced.

NOTE This is particularly important when you are mating nonprecision to precision devices.

Cleaning Connectors

Clean connectors are essential for ensuring the integrity of RF and microwave coaxial connections. Refer to [Table 6-3 on page 6-5](#) for part numbers for isopropyl alcohol and cleaning swabs.

WARNING Always use protective eyewear when using compressed air or nitrogen.

1. Use Compressed Air or Nitrogen

Use compressed air (or nitrogen) to loosen particles on the connector mating plane surfaces. Clean air cannot damage a connector or leave particles or residues behind.

You can use any source of clean, dry, low-pressure compressed air or nitrogen that has an effective oil-vapor filter and liquid condensation trap placed just before the outlet hose.

Ground the hose nozzle to prevent electrostatic discharge, and set the air pressure to less than 414 kPa (60 psi) to control the velocity of the air stream. High-velocity streams of compressed air can cause electrostatic effects when directed into a connector. These electrostatic effects can damage the device. Refer to [“Electrostatic Discharge” on page 3-2](#) for additional information.

WARNING Keep isopropyl alcohol away from heat, sparks, and flame. Store in a tightly closed container. Isopropyl alcohol is extremely flammable. In case of fire, use alcohol foam, dry chemical, or carbon dioxide: water may be ineffective.

Use isopropyl alcohol with adequate ventilation and avoid contact with eyes, skin, and clothing. It causes skin irritation, may cause eye damage, and is harmful if swallowed or inhaled. It may be harmful if absorbed through the skin. Keep away from heat, sparks, and flame. Wash thoroughly after handling.

In case of spill, soak up with sand or earth. Flush spill area with water.

Dispose of isopropyl alcohol in accordance with all applicable federal, state, and local environmental regulations.

2. Clean the Connector Threads

Use a lint-free swab or cleaning cloth moistened with isopropyl alcohol to remove any dirt or stubborn contaminants on a connector that cannot be removed with compressed air or nitrogen. Refer to [Table 6-3 on page 6-5](#) for a cleaning swab part number.

- a. Apply a small amount of isopropyl alcohol to the lint-free cleaning swab.
- b. Clean the connector threads.
- c. Let the alcohol evaporate, then blow the threads dry with a gentle stream of clean, low-pressure compressed air or nitrogen. Always completely dry a connector before you reassemble or use it.

3. Clean the Mating Plane Surfaces

- a. Apply a small amount of isopropyl alcohol to a new swab.
- b. Clean the center and outer conductor mating plane surfaces. Refer to [Figure 3-2 on page 3-4](#). When cleaning a female connector, avoid snagging the swab on the center conductor contact fingers by using short strokes.
- c. Let the alcohol evaporate, then blow the threads dry with a gentle stream of clean, low-pressure compressed air or nitrogen. Always completely dry a connector before you reassemble or use it.

4. Inspect Each Connector

Inspect the connector again to make sure that no particles or residue are present.

Gaging Connectors

The gages available from Agilent Technologies (see [Table 6-3 on page 6-5](#) for part number information) are intended for preventive maintenance and troubleshooting purposes only. They are effective in detecting excessive center conductor protrusion or recession, and conductor damage on DUTs, test accessories, and the calibration kit devices. *Do not use the gages for precise pin depth measurements.*

Connector Gage Accuracy

The connector gages are only capable of performing coarse measurements. They do not provide the degree of accuracy necessary to precisely measure the pin depth of the kit devices. This is partially due to the repeatability uncertainties that are associated with the measurement. Only the factory—through special gaging processes and electrical testing—can accurately verify the mechanical characteristics of the devices.

With proper technique, however, the gages are useful in detecting gross pin depth errors on device connectors. To achieve maximum accuracy, random errors must be reduced by taking the average of at least three measurements having different gage orientations on the connector. Even the resultant average can be in error by as much as ± 0.0001 inch due to systematic (biasing) errors usually resulting from worn gages and gage masters. The information in [Table 2-3 on page 2-4](#) assumes new gages and gage masters. Therefore, these systematic errors were not included in the uncertainty analysis. As the gages endure more use, the systematic errors can become more significant in the accuracy of the measurement.

The measurement uncertainties are primarily a function of the assembly materials and design, and the unique interaction each device type has with the gage. Therefore, these uncertainties can vary among the different devices. For example, note the difference between the uncertainties of the opens and shorts in [Table 2-3 on page 2-4](#).

The *observed* pin depth limits add these uncertainties to the *typical* factory pin depth values to provide practical limits that can be referenced when using the gages. See [“Pin Depth” on page 2-3](#). Refer to [“Kit Contents” on page 1-2](#) for more information on the design of the calibration devices in this kit.

NOTE When measuring pin depth, the measured value (resultant average of three or more measurements) contains measurement uncertainty and is not necessarily the true value. Always compare the measured value with the observed pin depth limits (which account for measurement uncertainties) in [Table 2-3 on page 2-4](#) to evaluate the condition of device connectors.

When to Gage Connectors

Gage a connector at the following times:

- Prior to using a device for the first time: record the pin depth measurement so that it can be compared with future readings. This serves as a good troubleshooting tool when you suspect damage may have occurred to the device.
- If either visual inspection or electrical performance suggests that the connector interface may be out of typical range (due to wear or damage, for example).
- If a verification device is used by someone else or on another system or piece of equipment.

Initially after every 100 connections, and after that as often as experience indicates.

Gaging Procedures

Gaging Male 3.5 mm Connectors

NOTE Always hold a connector gage by the gage barrel, below the dial indicator. This gives the best stability, and improves measurement accuracy. (Cradling the gage in your hand or holding it by the dial applies stress to the gage plunger mechanism through the dial indicator housing.)

1. Select the proper gage for your connector. Refer to [Table 6-3 on page 6-5](#) for gage part numbers.
2. Inspect and clean the gage, gage master, and device to be gaged. Refer to [“Visual Inspection” on page 3-3](#) and [“Cleaning Connectors” on page 3-5](#).
3. Zero the connector gage (refer to [Figure 3-3 on page 3-10](#)):
 - a. While holding the gage by the barrel, and without turning the gage or the device, screw the male gage master connecting nut onto the male gage, just until you meet resistance. Connect the nut finger tight. Do not overtighten.
 - b. Use the torque wrench recommended for use with the kit to tighten the connecting nut to 90 N-cm (8 in-lb). Refer to [“Connections” on page 3-13](#) for more information.
 - c. As you watch the gage pointer, gently tap the barrel of the gage to settle the reading. The gage pointer should line up exactly with the zero mark on the gage. If not, adjust the zero set knob until the gage pointer lines up exactly with zero.
 - d. Remove the gage master.
4. Gage the device connector (refer to [Figure 3-3 on page 3-10](#)):
 - a. While holding the gage by the barrel, and without turning the gage or the device, screw the connecting nut of the male device being measured onto the male gage, just until you meet resistance. Connect the nut finger-tight. Do not overtighten.
 - b. Use the torque wrench recommended for use with the kit to tighten the connecting nut to 90 N-cm (8 in-lb). Refer to [“Connections” on page 3-13](#) for more information.

- c. Gently tap the barrel of the gage with your finger to settle the gage reading.
- d. Read the gage indicator dial. Read *only* the black \pm signs; *not* the red \pm signs.

For maximum accuracy, measure the connector a minimum of three times and take an average of the readings. After each measurement, rotate the gage a quarter-turn to reduce measurement variations that result from the gage or the connector face not being exactly perpendicular to the center axis.

- e. Compare the average reading with the observed pin depth limits in [Table 2-3 on page 2-4](#).

Figure 3-3 Gaging Male 3.5 mm Connectors

Zero the Connector Gage

- Screw the male gage master connecting nut onto the male gage.
- Torque the connecting nut.
- Gently tap the gage barrel to settle the reading.
- Using the zero set knob, adjust the gage pointer to line up exactly with the zero mark.
- Remove the gage master.

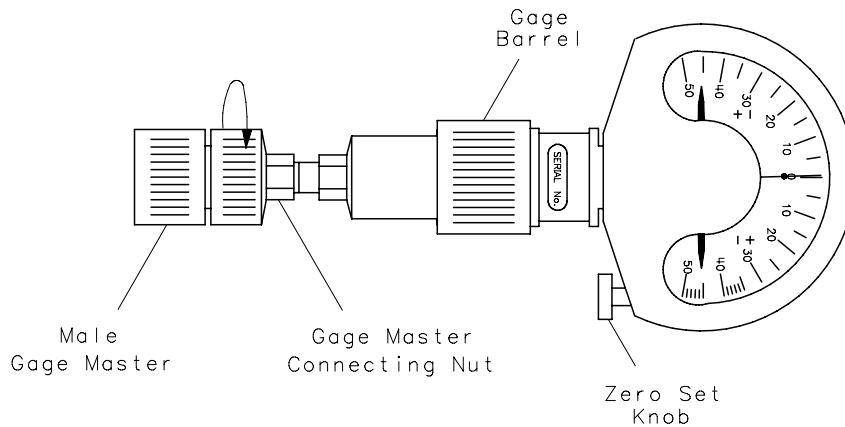

Gage the Device Connector

- Screw the male device connecting nut onto the male gage.
- Torque the connecting nut.
- Gently tap the gage barrel to settle the reading.
- Read recession or protrusion from the gage.
- Remove the device.

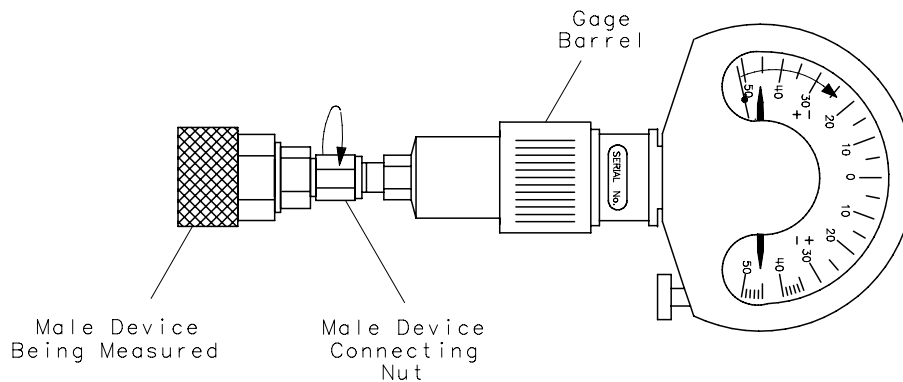

wj615d

Gaging Female 3.5 mm Connectors

NOTE Always hold a connector gage by the gage barrel, below the dial indicator. This gives the best stability, and improves measurement accuracy. (Cradling the gage in your hand or holding it by the dial applies stress to the gage plunger mechanism through the dial indicator housing.)

1. Select the proper gage for your connector. Refer to [Table 6-3 on page 6-5](#) for gage part numbers.
2. Inspect and clean the gage, gage master, and device to be gaged. Refer to [“Visual Inspection” on page 3-3](#) and [“Cleaning Connectors” on page 3-5](#) earlier in this chapter.
3. Zero the connector gage (refer to [Figure 3-4 on page 3-12](#)):
 - a. While holding the gage by the barrel, and without turning the gage or the device, screw the female gage connecting nut onto the female gage master, just until you meet resistance. Connect the nut finger-tight. Do not overtighten.
 - b. Use the torque wrench recommended for use with the kit to tighten the connecting nut to 90 N-cm (8 in-lb). Refer to [“Connections” on page 3-13](#) for more information.
 - c. As you watch the gage pointer, gently tap the barrel of the gage to settle the reading. The gage pointer should line up exactly with the zero mark on the gage. If not, adjust the zero set knob until the gage pointer lines up exactly with zero.
 - d. Remove the gage master.
4. Gage the device connector (refer to [Figure 3-4 on page 3-12](#)):
 - a. While holding the gage by the barrel, and without turning the gage or the device, screw the female gage connecting nut onto the female device being measured, just until you meet resistance. Connect the nut finger-tight. Do not overtighten.
 - b. Use the torque wrench recommended for use with the kit to tighten the connecting nut to 90 N-cm (8 in-lb). Refer to [“Connections” on page 3-13](#) for more information.
 - c. Gently tap the barrel of the gage with your finger to settle the gage reading.
 - d. Read the gage indicator dial. Read *only* the black \pm signs; *not* the red \pm signs.

For maximum accuracy, measure the connector a minimum of three times and take an average of the readings. Use different orientations of the gage within the connector. After each measurement, rotate the gage a quarter-turn to reduce measurement variations that result from the gage or the connector face not being exactly perpendicular to the center axis.
 - e. Compare the average reading with the observed pin depth limits in [Table 2-3 on page 2-4](#).

Figure 3-4 Gaging Female 3.5 mm Connectors

Zero the Connector Gage

- Screw the female gage connecting nut onto the female gage master.
- Torque the connecting nut.
- Gently tap the gage barrel to settle the reading.
- Using the zero set knob, adjust the gage pointer to line up exactly with the zero mark.
- Remove the gage master.

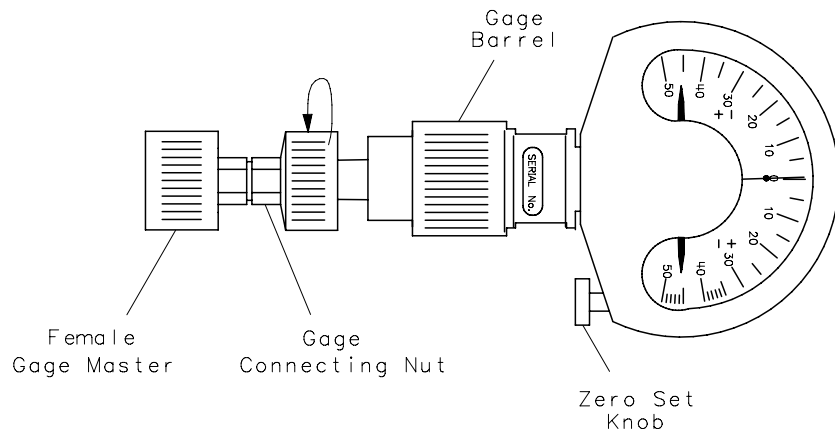

Gage the Device Connector

- Screw the female gage connecting nut onto the female device.
- Torque the connecting nut.
- Gently tap the gage barrel to settle the reading.
- Read recession or protrusion from the gage.
- Remove the device.

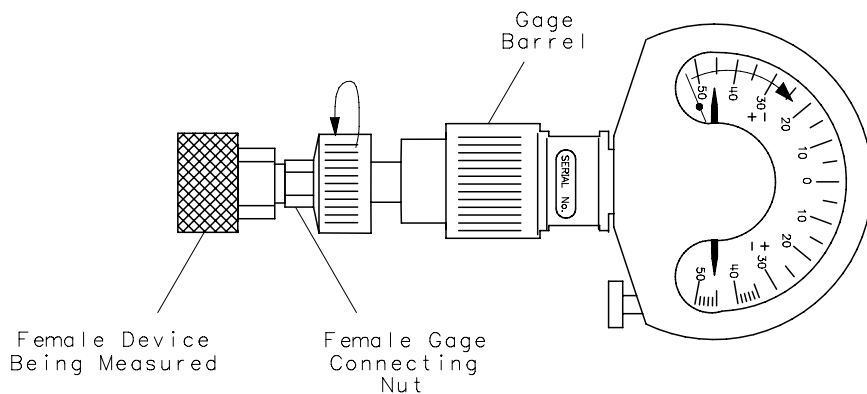

wj616d

Connections

Good connections require a skilled operator. *The most common cause of measurement error is poor connections.* The following procedures illustrate how to make good connections.

How to Make a Connection

Preliminary Connection

1. Ground yourself and all devices. Wear a grounded wrist strap and work on an antistatic mat. Refer to [“Electrostatic Discharge” on page 3-2](#) for ESD precautions.
2. Visually inspect the connectors. Refer to [“Visual Inspection” on page 3-3](#).
3. If necessary, clean the connectors. Refer to [“Cleaning Connectors” on page 3-5](#).
4. Use a connector gage to verify that all center conductors are within observed pin depth values in [Table 2-3 on page 2-4](#).
5. Carefully align the connectors. The male connector center pin must slip concentrically into the contact finger of the female connector.
6. Push the connectors straight together. Do *not* twist or screw them together. As the center conductors mate, there is usually a slight resistance.

CAUTION Do *not* turn the device body. Only turn the connector nut. Damage to the center conductor can occur if the device body is twisted.

7. The preliminary connection is tight enough when the mating plane surfaces make uniform, light contact. Do not overtighten this connection.

A connection in which the outer conductors make gentle contact at all points on both mating surfaces is sufficient. Very light finger pressure is enough.

8. Make sure the connectors are properly supported. Relieve any side pressure on the connection from long or heavy devices or cables.

Final Connection Using a Torque Wrench

NOTE Using a torque wrench guarantees that the connection is not too tight, preventing possible connector damage. It also guarantees that all connections are equally tight.

Table 3-1 Torque Wrench Information

Connector Type	Torque Setting	Torque Tolerance
3.5 mm	90 N-cm (8 in-lb)	± 9.0 N-cm (± 0.8 in-lb)

1. Turn the connector nut. This may be possible to do by hand if one of the connectors is fixed (as on a test port). In all situations, the use of an open-end wrench to keep the body of the device from turning is recommended.
2. Position both wrenches within 90 degrees of each other before applying force. Wrenches opposing each other (greater than 90 degrees apart) will cause a lifting action that can misalign and stress the connections of the device involved. This is especially true when several devices are connected together. See [Figure 3-5](#).

Figure 3-5 Wrench Positions

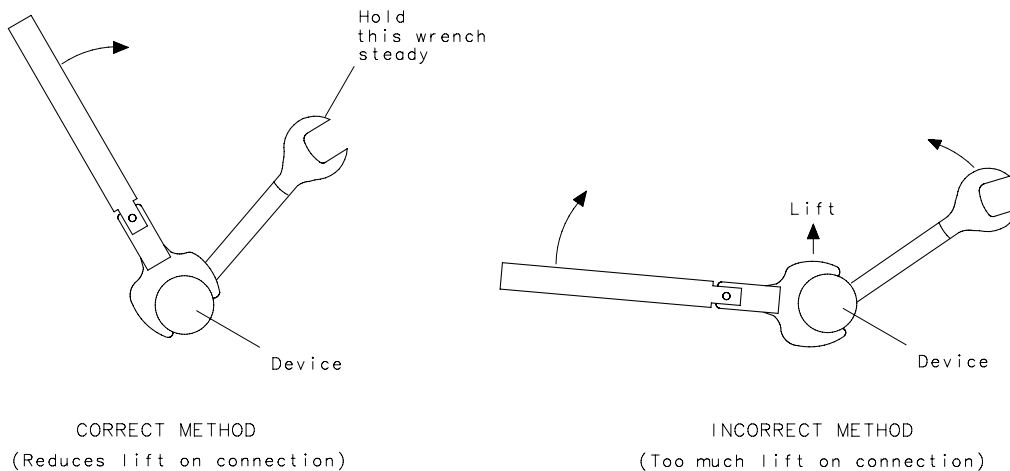

wj56f

3. Hold the torque wrench lightly, at the end of the handle only (beyond the groove). See [Figure 3-6](#).

Figure 3-6 Using the Torque Wrench

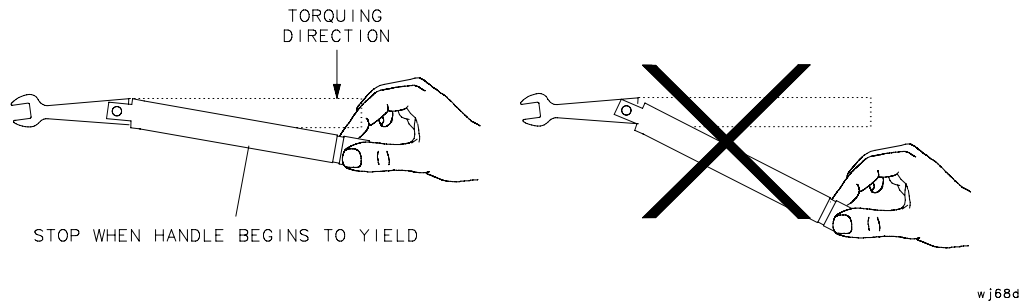

4. Apply force downward to the wrench handle. This applies torque to the connection *through* the wrench.

Do *not* hold the wrench so tightly that you push the handle straight down along its length rather than pivoting it, otherwise you apply an unknown amount of torque.

CAUTION You don't have to fully break the handle of the torque wrench to reach the specified torque; doing so can cause the handle to kick back and loosen the connection. Any give at all in the handle is sufficient torque.

5. Tighten the connection just to the torque wrench break point. The wrench handle gives way at its internal pivot point. See [Figure 3-6](#). Do *not* tighten the connection further.

Do not pivot the wrench handle on your thumb or other fingers, otherwise you apply an unknown amount of torque to the connection when the wrench reaches its break point.

Do not twist the head of the wrench relative to the outer conductor mating plane. If you do, you apply more than the recommended torque.

How to Separate a Connection

To avoid lateral (bending) force on the connector mating plane surfaces, always support the devices and connections.

CAUTION Turn the connector nut, *not* the device body. Major damage to the center conductor can occur if the device body is twisted.

1. Use an open-end wrench to prevent the device body from turning.
2. Use another open-end wrench to loosen the connector nut.
3. Complete the separation by hand, turning only the connector nut.
4. Pull the connectors straight apart without twisting, rocking, or bending.

Handling and Storage

- Use the plastic end caps and store the calibration devices in the foam-lined storage case when not in use.
- Never store connectors loose in a box, in a desk, or in a bench drawer. This is the most common cause of connector damage during storage.
- Keep connectors clean.
- Do not touch mating plane surfaces. Natural skin oils and microscopic particles of dirt are easily transferred to a connector interface and are very difficult to remove.
- Do not set connectors contact-end down on a hard surface. The plating and the mating plane surfaces can be damaged if the interface comes in contact with any hard surface.

4 Performance Verification

Introduction

The performance of your calibration kit can only be verified by returning the kit to Agilent Technologies for recertification. The equipment required to verify the specifications of the devices inside the kit has been specially manufactured and is not commercially available.

How Agilent Verifies the Devices in This Kit

Agilent verifies the specifications of these devices as follows:

1. The residual microwave error terms of the test system are verified with precision airlines and shorts that are directly traced to NIST (National Institute of Standards and Technology). The airline and short characteristics are developed from mechanical measurements. The mechanical measurements and material properties are carefully modeled to give very accurate electrical representation. The mechanical measurements are then traced back to NIST through various plug and ring gages and other mechanical measurements.
2. Each calibration device is electrically tested on this system. For the initial (before sale) testing of the calibration devices, Agilent includes the test measurement uncertainty as a guardband to guarantee each device meets the published specification. For recertifications (after sale), no guardband is used and the measured data is compared directly with the specification to determine the pass/fail status. The measurement uncertainty for each device is, however, recorded in the calibration report that accompanies recertified kits.

Recertification

The following will be provided with a recertified kit:

- new calibration sticker affixed to the case
- certificate of calibration
- a calibration report for each device in the kit listing measured values, specification, and uncertainties

NOTE A list of NIST traceable numbers may be purchased upon request to be included in the calibration report.

Agilent Technologies offers a *Standard* calibration for the recertification of this kit. For more information, contact Agilent Technologies. For contact information, see “Contacting Agilent” on page 4.

How Often to Recertify

The suggested initial interval for recertification is 12 months or sooner. The actual need for recertification depends on the use of the kit. After reviewing the results of the initial recertification, you may establish a different recertification interval that reflects the usage and wear of the kit.

NOTE The recertification interval should begin on the date the kit is *first used* after the recertification date.

Where to Send a Kit for Recertification

Contact Agilent Technologies for information on where to send your kit for recertification. For contact information, see “Contacting Agilent” on page 4.

When you return the kit, fill out and attach a service tag. Refer to [“Returning a Kit or Device to Agilent” on page 5-4](#) for details.

5 Troubleshooting

Troubleshooting Process

If you suspect a bad calibration, or if your network analyzer does not pass performance verification, follow the steps in [Figure 5-1](#).

Figure 5-1 Troubleshooting Flowchart

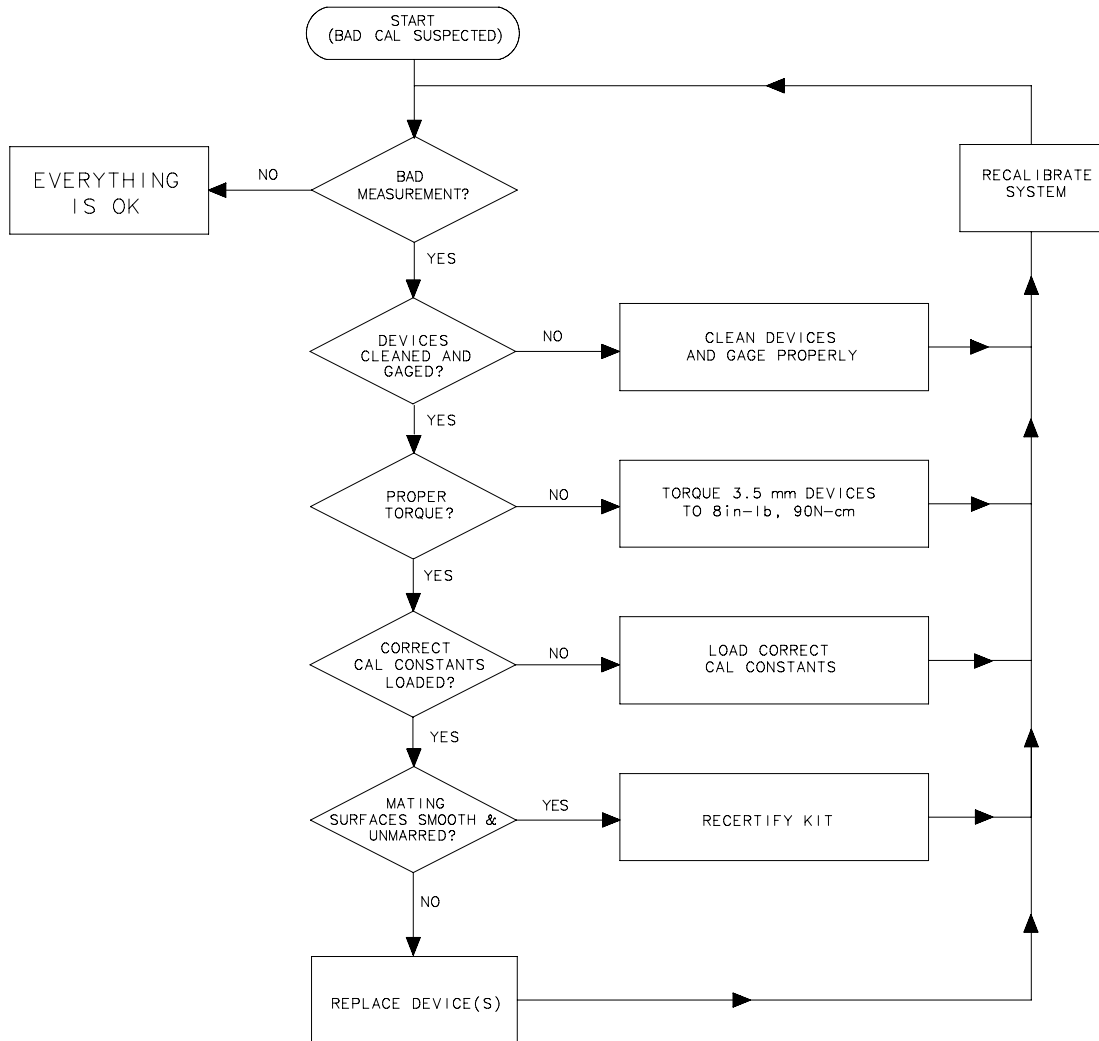

wj69d

Where to Look for More Information

This manual contains limited information about network analyzer system operation. For detailed information on using a VNA, ENA or PNA series network analyzer, refer to the appropriate user guide or online Help.

- To view the ENA or PNA online Help, press the Help key on the front panel of the network analyzer.
- To view an online VNA user guide, use the following steps:
 1. Go to *www.agilent.com*.
 2. Enter your VNA model number (Ex: 8753ES) in the Search box and click **Search**.
 3. Under the heading **Manuals**, click on the title/hyperlink for the document PDF you want to view.

If you need additional information, see “Contacting Agilent” on page 4.

Returning a Kit or Device to Agilent

If your kit or device requires service, contact Agilent Technologies for information on where to send it. See “Contacting Agilent” on page 4. Include a service tag (found at the end of this manual) on which you provide the following information:

- your company name and address
- a technical contact person within your company, and the person's complete phone number
- the model number and serial number of the kit
- the part number and serial number of each device
- the type of service required
- a *detailed* description of the problem and how the device was being used when the problem occurred (such as calibration or measurement)

Contacting Agilent

Assistance with test and measurements needs and information on finding a local Agilent office are available on the Web at:

www.agilent.com/find/assist

If you do not have access to the Internet, please contact your Agilent field engineer.

NOTE In any correspondence or telephone conversation, refer to the Agilent product by its model number and full serial number. With this information, the Agilent representative can determine whether your product is still within its warranty period.

6 Replaceable Parts

Introduction

[Table 6-1](#) lists the replacement part numbers for items included in the 85033E calibration kit and [Figure 6-1](#) illustrates each of these items.

[Table 6-2](#) lists the replacement part numbers for adapters that are available as options.

[Table 6-3](#) lists the replacement part numbers for items not included in the calibration kit that are either required or recommended for successful operation of the kit.

To order a listed part, note the description, the part number, and the quantity desired. Telephone or send your order to Agilent Technologies. For contact information, see [“Contacting Agilent” on page 5-4](#).

Figure 6-1 Replaceable Parts for the 85033E Calibration Kit

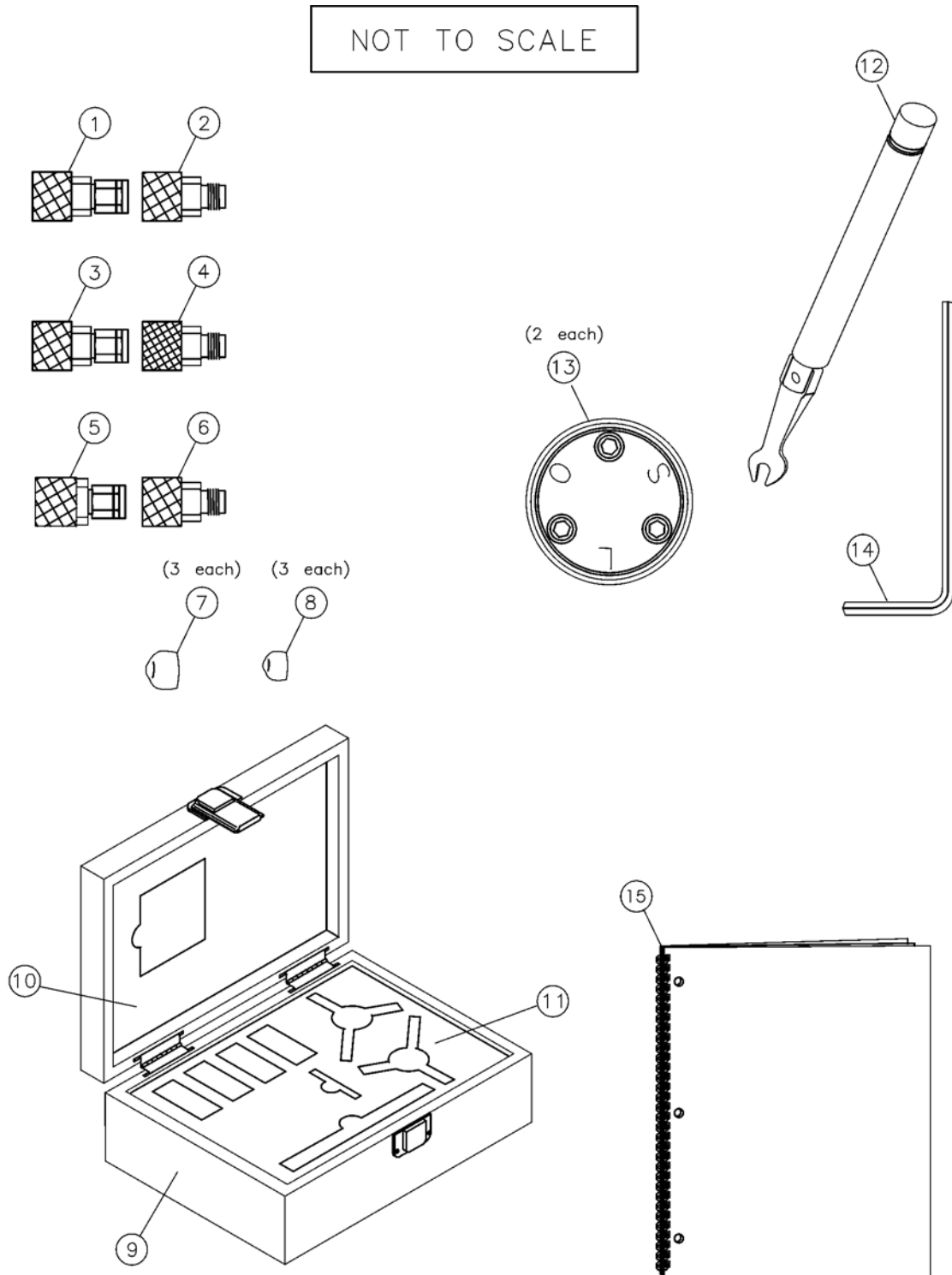

wj61e

Table 6-1 Replaceable Parts

Item No.	Description	Qty	Agilent Part Number
Calibration Devices^a			
1	3.5 mm -m- broadband load	1	85033-60016
2	3.5 mm -f- broadband load	1	85033-60017
3	3.5 mm -m- offset open	1	85033-60018
4	3.5 mm -f- offset open	1	85033-60019
5	3.5 mm -m- offset short	1	85033-60020
6	3.5 mm -f- offset short	1	85033-60021
Protective End Caps for Connectors^a			
7	3.5 mm -m- connectors	as required	1401-0208
8	3.5 mm -f- connectors	as required	1401-0202
Calibration Kit Storage Case			
9	Box (without foam pads)	1	5180-8446
10	Box pad (top)	1	85032-80028
11	Box pad (bottom)	1	85033-80025
Miscellaneous Items			
12	5/16 in, 90 N-cm (8 in-lb) torque wrench	1	8710-1765
13	Open-short-load holder	2	85033-40001
14	2.5 mm hex key	1	8710-1181
15	User's and service guide ^b	1	85033-90028
	Connector care-quick reference card (not shown in Figure 6-1)	1	08510-90360

a. See [“Clarifying the Terminology of a Connector Interface”](#) on page 1-8.

b. See [“Printing Copies of Documentation from the Web”](#) on page -ii

Table 6-2 Adapters

Description	Qty	Agilent Part Number
Option 100^a		
3.5 mm -f- to -f-	1	85027-60005
Option 200^a		
3.5 mm -m- to -m-	1	85027-60007
Option 300^a		
3.5 mm -f- to -m-	1	85027-60006
Option 400^a		
Type-N -m- to 3.5 mm -m-	1	1250-1743
Type-N -m- to 3.5 mm -f-	1	1250-1744
Type-N -f- to 3.5 mm -f-	1	1250-1745
Type-N -f- to 3.5 mm -m-	1	1250-1750
Option 500^a		
3.5 mm -m- to APC7	2	1250-1746
3.5 mm -f- to APC7	2	1250-1747

a. See “Clarifying the Terminology of a Connector Interface” on page 1-8.

Table 6-3 Items Not Included in Kit

Description	Agilent Part Number
3.5 mm -f- gage set	11752-60105
3.5 mm -m- gage set	11752-60106
Anhydrous isopropyl alcohol (>92% pure) ^a	--
Cleaning swabs (100)	9301-1243
Grounding wrist strap	9300-1367
5 ft. grounding cord for wrist strap	9300-0980
2 x 4 ft. conductive table mat and 15 ft. ground wire	9300-0797
ESD heel strap	9300-1308

a. Agilent can no longer safely ship isopropyl alcohol, so customers should purchase it locally.

A Standard Definitions

Class Assignments and Standard Definitions Values are Available on the Web

Class assignments and standard definitions may change as more accurate model and calibration methods are developed. You can download the most recent class assignments and standard definitions from Agilent's Calibration Kit Definitions Web page at <http://na.tm.agilent.com/pna/caldefs/stddefs.html>.

For a detailed discussion of calibration kits, refer to the Agilent Application Note, "Specifying Calibration Standards and Kits for Agilent Vector Network Analyzers." This application note covers calibration standard definitions, calibration kit content and its structure requirements for Agilent vector network analyzers. It also provides some examples of how to set up a new calibration kit and how to modify an existing calibration kit definition file. To download a free copy, go to www.agilent.com and enter literature number 5989-4840EN in the Search window.

Numerics

8510 network analyzer, [1-3](#)

A

adapters, [6-2](#)
Agilent Technologies
application note, [A-2](#)

B

broadband loads, [1-2](#)

C

calibration
Agilent Application Note, [A-2](#)
certificate of, [4-2](#)
constants, *See* calibration
definitions
definitions, [1-3](#)
entering, [1-3](#)
frequency, [1-9](#)
report, [4-2](#)
temperature, [2-2](#)
when to perform, [1-9](#)
calibration kit
contents, [1-2](#)
modifying definition files, [A-2](#)
overview, [1-2](#)
certificate of calibration, [4-2](#)
characteristics
electrical, [2-6](#)
mechanical, [2-3](#)
supplemental, [2-6](#)
class assignments
downloading from Agilent Web
site, [A-2](#)
cleaning connectors, [3-5](#)
compressed air or nitrogen, [3-5](#)
connections, [3-2](#), [3-13](#), [3-14](#), [3-15](#)
connector
cleaning, [3-5](#)
defective, [3-3](#)
female, [3-11](#)
gaging, [3-7](#)
when to do, [3-8](#)
male, [3-8](#)
precision slotless (female), [1-7](#)
slotted, [3-4](#)
terminology, [1-8](#)
threads, [3-5](#)
visual inspection, [3-3](#)
wear, [3-3](#)
connector gage
handling, [3-8](#), [3-11](#)
zeroing, [3-8](#), [3-11](#)
constants, calibration, *See*
calibration definitions

contents
incomplete
what to do, [1-5](#)

D

damage
what to do, [1-5](#)
damaged connectors, [3-3](#)
data, recertification, [4-2](#)
defective connectors, [3-3](#)
definitions
calibration, [1-3](#)
entering, [1-3](#)
permanently stored, [1-3](#)
deviation from nominal phase, [2-5](#)
device
connecting, [3-13](#)
disconnecting, [3-15](#)
handling, [3-16](#)
maintenance, [1-8](#)
storage, [3-16](#)
temperature, [2-2](#)
visual inspection, [3-3](#)
dimensions, [2-3](#)
disconnections, [3-15](#)
downloading class assignments &
std definitions from the Web,
[A-2](#)

E

electrical characteristics, [2-6](#)
electrical specifications, [2-5](#)
electrostatic discharge, [3-2](#)
environmental requirements, [2-2](#)
equipment required, [1-4](#)
ESD, [3-2](#)
precautions, [3-2](#)

F

frequency of calibration, [1-9](#)

G

gage
connector
handling, [3-8](#), [3-11](#)
zeroing, [3-8](#), [3-11](#)
gaging
connectors
when to do, [3-8](#)
female connectors, [3-11](#)
male connectors, [3-8](#)
gaging connectors, [3-7](#)

H

handling, [3-16](#)

how often to calibrate, [1-9](#)
humidity, [2-2](#)

I

incoming inspection, [1-5](#)
information, troubleshooting, [5-3](#)
inspection
damage, [3-3](#)
defects, [3-3](#)
incoming, [1-5](#)
mating plane, [3-3](#)
slotted connectors, [3-4](#)
visual, [3-3](#)

K

kit contents, calibration, [1-2](#)
kit overview, contents, [1-2](#)

L

loads, broadband, [1-2](#)

M

maintenance, [3-2](#)
preventive, [1-8](#)
maintenance of devices, [1-8](#)
making connections, [3-13](#)
manual
printing, [1-ii](#)
mating plane inspection, [3-3](#)
mechanical characteristics, [2-3](#)
modifying calibration kit
definition files, [A-2](#)

N

network analyzer, 8510, [1-3](#)
nitrogen, [3-5](#)

O

offsets, [1-2](#)
opens and shorts, [1-2](#)
options, [1-4](#)
ordering parts, [6-1](#)
overview of kit, [1-2](#)

P

part numbers, [6-2](#)
parts, replacing, [6-1](#)
performance verification, [4-2](#)
pin depth, [2-3](#)
precision slotless connectors, [1-7](#)
preventive maintenance, [1-8](#)

R

recertification, [4-2](#)

interval, [4-3](#)
 where it's done, [4-3](#)
replaceable parts, [6-1](#)
requirements, environmental, [2-2](#)
return loss, [2-5](#)
return, kit or device, [5-4](#)

S

serial numbers, [1-6](#)
service
 tag, [1-5](#)
slotted connectors, [3-4](#)
specifications, [2-2](#)
 electrical, [2-5](#)
 environmental, [2-2](#)
 temperature, [2-2](#)
 verifying, [4-2](#)
standard definitions
 downloading from Agilent Web
 site, [A-2](#)
static discharge, [3-2](#)
storage, [3-16](#)
supplemental characteristics, [2-6](#)

T

tag
 service, [1-5](#)
temperature
 calibration, [2-2](#)
 device, [2-2](#)
 error-corrected temperature
 range, [2-2](#)
 measurement, [2-2](#)
 operating range, [2-2](#)
 verification and measurement,
 [2-2](#)
terminology, connector, [1-8](#)
test data, [4-2](#)
torque wrench, [3-14](#)
traceability, [4-2](#)
troubleshooting, [5-2](#)

V

verification
 performance, [4-2](#)
 temperature, [2-2](#)
visual inspection, [3-3](#)

W

when to calibrate, [1-9](#)

Z

zeroing
 connector gage, [3-8](#), [3-11](#)