



8003 Precision Scalar Analyzer

Operation Manual

8003

ISO 9001 Certified Process
Registrar: BSI, Certification No. FM 34226 ♦ Registered 04 June 1996 ♦ Amended 01 March 2000

Giga-tronics Incorporated ♦ 4650 Norris Canyon Road ♦ San Ramon, California 94583
925.328.4650 or 800.726.4442 ♦ 925.328.4700 (Fax) ♦ 800.444.2878 (Customer Service) ♦ 925.328.4702 (CS Fax)
www.gigatronics.com

All technical data and specifications in this manual are subject to change without prior notice and do not represent a commitment on the part of Giga-tronics Incorporated.

© 2001 Giga-tronics Incorporated. All rights reserved.

Printed in the USA.

WARRANTY

Giga-tronics Series 8003 instrument is warranted against defective materials and workmanship for one year from date of shipment. Giga-tronics will at its option repair or replace products that are proven defective during the warranty period. This warranty DOES NOT cover damage resulting from improper use, nor workmanship other than Giga-tronics service. There is no implied warranty of fitness for a particular purpose, nor is Giga-tronics liable for any consequential damages. Specification and price change privileges are reserved by Giga-tronics.

Exclusion of Other Warranties

The Warranty described above is Buyer's sole and exclusive remedy and no other Warranty, whether written or oral, is expressed or implied. Giga-tronics specifically disclaims the implied warranties of merchantability and fitness for a particular purpose. No statement, representing, agreement, or understanding, oral or written, made by an agent, distributor, representative, or employee of Giga-tronics, which is not contained in the foregoing Warranty will be binding upon Giga-tronics, unless made in writing and executed by an authorized Giga-tronics employee. Under no circumstances shall Giga-tronics be liable for any direct, indirect, special, incidental, or consequential damages, expenses, losses, or delays (including loss of profit) based on contract, tort, or any other legal theory.

SUPPLEMENTARY DATA

Spec 5554

This special consists of the following items:

Part Number	Description	Qty
19169	Model 8003	1
20065	Model 80301A, Sensor	1
20066	Model 80302A, Sensor	1
14117-003	Cable Assy, BNC to BNC, 4 ft	3
20779	Bridge Adapter	1
20791	Oper Manual Kit, 8003	2
20791-001	Maint Manual Kit, 8003	2
21032-002	Wood Box	1
21529	uW Return Loss Bridge	1
21531	Adapter, prec GPC-7 to N(M)	3
21532	Adapter, prec GPC-7 to N(F)	3
21533	Termination, GPC-7, 50 ohm	1
21534	uW Power Splitter	1
21536	Cable, RF N(M)	1
21660	Foam Insert, Top	1
21661	Foam Insert, Btm	1
21663	Nameplate, 8003-S554	1
21664	Label, Cal not required	16

REV	A		
ECO	PROD REL		
DATE	04-21-94		
SHEETS AFFECTED	ALL		
ORIG	Dan Watson	DATE	04-21-94
		QA	Vic Itow
		DATE	04-21-94
ENG	Dan Watson	DATE	04-21-94
		MKTG	Dave White
		DATE	04-21-94
MFG	Tim Lowe	DATE	04-21-94
<i>Giga-tronics</i>		DOCUMENT NO.	S5554
		SHEET NO.	1
		CONT. ON	--
		LAST REVISED (DATE)	04-21-94

IMPORTANT NOTICE

Using Password Protection with the 8003

The Giga-tronics 8003 Precision Scalar Analyzer is shipped from the factory with the password protection feature OFF. Password protection can be user activated to prevent unauthorized changes in the Cal Factor and Calibrator data stored in the EEPROMs in the 8003 and sensors used with the instrument. It is strongly recommended that this password protection be implemented immediately to prevent any problems that could arise due to accidental or unintentional changes to the calibration data stored in the EEPROMs. Use the following procedure to activate the password protection for the sensors and/or bridge:

1. Since the password is stored directly in the EEPROM physically contained in the housing of each sensor, attach the sensor(s) to be protected to the A, B and/or C connections on the front panel of the 8003.



NOTE: *Sensors can be moved from one instrument to another, and will still retain their password protection.*

2. After the 8003 has been turned on, press the CONFIG key on the front panel.
3. The display will present the primary CONFIG menu. Press the *SERVICE* softkey at the bottom of the menu.
4. Press the *SENSOR EEPROM* softkey of the next menu presented.
5. A menu will then be displayed showing a choice of sensors A, B or C. Each sensor must be individually password protected. Either the same or different passwords can be used for each individual sensor.
6. Assuming that sensors are attached to all 3 inputs, press the *SENSOR A EEPROM* softkey. (If sensors are not connected to all 3 inputs, repeat the procedure that follows for just the sensors being used.)
7. Press the *PASSWD* softkey of the next menu presented, and then press the *DEFINE PASSWD* softkey of the menu that follows.
8. After the *DEFINE PASSWD* softkey has been pressed, a prompt will be displayed asking for a password. Six number keys (the selected password sequence) should then be pressed. These keys will not be shown on the screen.
9. Once the six number keys have been pressed, the display will again present a prompt asking that the password just defined be entered again for confirmation. When the password has been confirmed, the defined password will then be accepted.
10. Then press *RETURN* and *PROGRAM EEPROM* to store the password in the sensor EEPROM. From this point on, the password must be entered before any calibration data can be changed in the sensor EEPROM.
11. Start with Step 6 for the next sensor to be protected.

For further information on accessing the softkeys used to store a password in the sensor EEPROM, see pages 2-64 and 2-65 in the OPERATION chapter (Operation Manual).

1. The following procedure should be used to activate password protection for the calibrator in the 8003.
2. Press the CONFIG key on the front panel, and then press the *SERVICE* softkey at the bottom of the primary CONFIG menu.
3. Press the *SET CAL* softkey at the top of the next menu presented.

The next menu will contain a softkey label called *DEFINE PASSWD*. The *DEFINE PASSWD* softkey is used to define a password that future users will have to enter in order to change the calibrator output. When this softkey is pressed, a prompt is presented asking for a new password. Six number keys (the selected password sequence) should then be pressed. The keys being pressed will not be shown on the screen. Once the six number keys have been pressed, the display will again present a prompt asking that the password just defined be entered again to confirm the password. When the password is confirmed, the defined password will be enabled.



NOTE: *Jumper W1 on the Calibrator Board must be moved to pins 2 and 3 from pins 1 and 2 to complete the enabling of password protection.*

(The *CLEAR PASSWD* softkey in the same menu as above is used to clear the password. Once this softkey is pressed, the password will be cleared and future users will be able to adjust the calibrator output without having to know a password until one is assigned again).

Further information on accessing the softkeys used in setting the calibrator output is given on page 2-61 in the OPERATION chapter (Operation Manual).

Contents

About This Manual	ix
Conventions	xi
Record of Manual Changes	xiii
Special Configurations	xv

1

Introduction

1.1	Description	1-1
1.1.1	Features	1-1
1.2	Installation	1-2
1.2.1	Safety Precautions	1-2
1.2.1.1	Power Input, Fuse & Voltage Selector	1-3
1.2.2	Line Voltage & Fuse Selection	1-3
1.2.2.1	Power Sensors	1-3
1.2.2.2	Power Sensors Accessories	1-3
1.2.3	Power Sensor Precautions	1-3
1.2.4	Power Requirements	1-4
1.2.4.1	Standard Voltage Selector & Fuse Holder	1-5
1.2.4.2	VDE Type Voltage Selector & Fuse Holder	1-5
1.2.5	Environmental Requirements	1-5
1.2.6	Items Furnished	1-5
1.2.7	Items Required	1-6
1.2.8	Tools & Test Equipment	1-6
1.2.9	Cooling	1-6
1.2.10	Cleaning	1-6
1.2.11	Receiving Inspection	1-6
1.2.12	Preparation for Reshipment	1-6
1.3	Specifications	1-7
1.3.1	Cursors & Markers	1-8
1.3.2	Accuracy	1-9
1.3.2.1	Transmission Loss or Gain Measurements	1-9
1.3.2.2	Reflection Measurements	1-10
1.3.2.3	Absolute Power Measurement Accuracy	1-11
1.4	GPIB Interface	1-13
1.5	Rear Panel Inputs & Outputs	1-14
1.5.1	BNC Connectors	1-14
1.5.2	GPIB Connectors	1-14
1.6	Signal Sources	1-15
1.6.1	System Integrated	1-15
1.6.2	Operator Integrated	1-15
1.6.3	Modulation	1-15
1.7	General Specifications	1-15

2

Operation

2.1	Introduction.....	2-1
2.2	Front & Rear Panel Descriptions.....	2-1
2.2.1	GPIB Address Selection	2-7
2.2.2	Display Description	2-8
2.3	Softkey Functional Description	2-12
2.3.1	Softkey Labels & Color Indications	2-12
2.3.2	Channel & Function Selection	2-12
2.3.3	Sensors & Sensor Calibration	2-12
2.3.4	Absolute Power & Swept Capabilities	2-13
2.3.5	Graph & Readout Display Modes	2-13
2.3.6	Path Calibration Memory	2-13
2.3.7	Trace Memory	2-14
2.3.8	Power On	2-14
2.4	CHANNEL Controls.....	2-15
2.4.1	OFF Key	2-15
2.4.2	DEFINE Key	2-15
2.5	FUNCTION Controls.....	2-18
2.5.1	MEAS Key	2-18
2.5.2	SCALE Key	2-22
2.5.3	DISPLAY Key	2-24
2.5.4	CAL Key	2-36
2.5.5	CURSOR Key	2-40
2.5.6	MEMORY Key	2-47
2.6	SOURCE Controls.....	2-51
2.6.1	General Description	2-51
2.6.2	ATE Operation	2-51
2.6.3	8003 Source Compatibility	2-51
2.6.4	Key Operation	2-52
2.6.4.1	UPDATE SWEEPER ON/OFF Key	2-52
2.6.4.2	START Key	2-52
2.6.4.3	STOP Key	2-53
2.6.5	POWER Key	2-54
2.6.6	SWEEP TIME Key	2-56
2.7	SYSTEM Controls.....	2-57
2.7.1	PRESET Key	2-57
2.7.2	CONFIG Key	2-57
2.8	Front Panel Operation.....	2-66
2.8.1	Calibrating for Power Measurement	2-67
2.8.1.1	Calibration Intervals.....	2-68
2.8.2	Path Calibration Correction for Component Variations	2-69
2.8.2.1	Set Up Sweep Parameters.....	2-69
2.8.2.2	Frequency Response Correction	2-70
2.8.3	Making a Device Measurement	2-73
2.9	Insertion & Return Loss Measurements.....	2-75
2.9.1	Single-Sensor Insertion Loss Measurement	2-75
2.9.1.1	Using Channels	2-76
2.9.2	Two-Sensor Insertion Loss Measurements	2-77
2.9.3	Single-Sensor Return Loss Measurements	2-79
2.9.4	Two-Sensor Return Loss Measurements	2-81
2.9.5	Three-Sensor Configurations	2-82
2.9.6	Trace Memory	2-82

2.10	Scaling the Display.....	2-84
2.10.1	Hints on Simplified Scaling	2-86
2.10.2	Using the Cursor to Set the Reference Level	2-86
2.11	Cursors & Markers	2-87
2.11.1	Search Functions Using the Cursor	2-87
2.11.2	Min & Max Search	2-87
2.11.3	Searches on Frequency Selective Devices	2-89
2.11.4	Bandwidth Searches	2-91
2.11.5	Cursor Delta (Δ) Functions	2-92
2.11.6	Cursors on Multiple Channels	2-93
2.11.7	Markers	2-94
2.12	Power Measurements	2-95
2.12.1	CW Power Measurements	2-98
2.12.2	Mixed Mode Measurements	2-98
2.12.3	Cal Factor Corrections in the CW Mode	2-99
2.12.4	Sensor Offsets	2-100
2.12.5	Other CW Functions	2-100
2.13	Accurate Range Measurements.....	2-102
2.13.1	Temperature Stability	2-102
2.13.2	Measurement Modes	2-102
2.13.2.1	CW Mode.....	2-102
2.13.2.2	Swept Mode with AC Detection.....	2-103
2.13.2.3	Swept Mode with DC Detection.....	2-103
2.14	8003 Power Sweep Measurements.....	2-104

3

Remote Operation

3.1	Introduction	3-1
3.2	IEEE Bus Interface	3-1
3.2.1	Connect the System Controller	3-1
3.2.2	Set the GPIB Address	3-1
3.2.2.1	Programming the 8003	3-2
3.3	Structured GPIB Language	3-7
3.3.1	Common Structure	3-7
3.3.2	8003 GPIB Commands	3-7
3.3.3	Command Execution	3-10
3.3.3.1	<i>hs</i> Definition.....	3-10
3.3.3.2	<i>ds</i> Definition.....	3-10
3.3.3.3	<i>us</i> Definition.....	3-10
3.3.3.4	EOL Definition.....	3-10
3.3.3.5	Case Insensitivity	3-10
3.3.4	IEEE GPIB Interface Characteristics	3-11
3.3.5	Channel Bias Voltage Definition Command Structure	3-12
3.3.6	Sensor Calibration Command Structure	3-12
3.3.7	Channel Definition Command Structure	3-13
3.3.8	Cursor Definition Command Structure	3-14
3.3.9	Instrument Preset Command Structure	3-18
3.3.10	Disable Private Bus Command Structure	3-19
3.3.11	Enable Private Bus Command Structure	3-19
3.3.12	External Status Register Query Command Structure	3-20
3.3.13	Fixed Frequency Source Mode Definition Command Structure	3-21
3.3.14	Graph Display Definition Command Structure	3-23
3.3.15	Instrument Identifier Command Structure	3-23
3.3.16	Input Command Structure	3-24
3.3.17	Key Stroke Emulation Enable/Disable Command Structure	3-25
3.3.18	Memory Command Structure	3-29
3.3.19	Measurement Query Command Structure	3-30
3.3.20	Plot Command Structure	3-33

8003 Precision Scalar Analyzer

3.3.21	CW Power Measurement Command Structure	3-36
3.3.22	Temperature & Low Level Offset Update Structure	3-49
3.3.23	Print Definition Command Structure	3-49
3.3.24	Readout Display Definition Command Structure	3-50
3.3.25	Sensor Definition Command Structure	3-51
3.3.26	Sensor Short/Open Calibration Command Structure	3-53
3.3.27	Swept Measurement Command Structure	3-54
3.3.28	Start/Stop Swept Frequency Source Mode Def. Cmd. Structure ..	3-64
3.3.29	Span Swept Frequency Source Mode Def. Cmd. Structure	3-67
3.3.30	Sensor Path Calibration Command Structure	3-69
3.3.31	Sensor Zeroing Command Structure	3-70
3.3.32	STATUS MESSAGES	3-70
3.3.32.1	488.2 Status Byte.....	3-70
3.3.32.2	488.2 External Status.....	3-71
3.3.33	GPIB/PRIVATE Interface	3-71
3.3.34	Pass Through Feature	3-72

4

Performance Test & Calibration

4.1	General.....	4-1
4.2	Calibrator Verification Procedure.....	4-3
4.2.1	Calibrator Output Power Reference Level	4-3
4.2.1.1	Procedure.....	4-3
4.2.2	Calibrator Frequency Check	4-5
4.3	Performance Verification Tests	4-6
4.3.1	Equipment Required	4-6
4.3.2	Instrument Plus Power Sensor Linearity	4-7
4.3.2.1	Test Description	4-7
4.3.2.2	Setup Parameters.....	4-8
4.3.2.3	Test Procedure	4-8
4.3.3	Serial Port Check	4-10
4.3.4	GPIB/System Port Check	4-10
4.3.5	GPIB/Private Port Check	4-11
4.3.6	Sweep in Connector Check	4-11
4.3.7	AC Mode Output Connector Check	4-12
4.3.8	Bias Output Connector Check	4-12
4.3.9	DAC Output Connector Check	4-13
4.3.10	RGB Video Output Connector Check	4-13
4.3.11	SUMMARY	4-13

A

Power Sensors

A.1	Introduction.....	A-1
A.2	Power Sensor Selection.....	A-1
A.2.1	Power Sensor Selection Charts	A-2
A.2.2	Directional Bridges.....	A-4

B

System Configuration

B.1	Introduction	B-1
B.2	8003 Default Parameters.....	B-1
B.3	8003 System.....	B-3
B.3.1	Sensor Installation	B-3
B.3.2	Bridge Installation	B-3
B.3.3	Sweeper Installation	B-4
	B.3.3.1 8003 to Sweeper BNC Connections	B-4
	B.3.3.2 GPIB Interconnect Cable Connections	B-5
B.4	Printer Installation	B-6
B.4.1	PaintJet Color GPIB Cable Interconnections	B-7
B.4.2	ThinkJet GPIB Cable Interconnections.....	B-7
B.4.3	LaserJet Family RS-232 Cable Interconnections.....	B-8
	B.4.3.1 RS-232 Electrical Description	B-8
B.4.4	LaserJet Printer Switch & Jumper Location and Settings.....	B-9
B.5	Plotter GPIB Installation Interconnections & Pen Colors.....	B-10
B.5.1	HP 7550A	B-10
	B.5.1.1 HP 7550A Pen Color Format (8 Pens).....	B-10
B.5.2	HP 7440A	B-11
	B.5.2.1 HP 7440A Pen Color Format (8 Pens).....	B-11
B.5.3	HP 7475A	B-12
	B.5.3.1 HP 7475A Pen Color Format (6 Pens).....	B-12
B.5.4	HP 7470A	B-13
	B.5.4.1 HP 7470A Pen Color Format (2 Pens).....	B-13
B.5.5	HP 7090A	B-14
	B.5.5.1 HP 7090A Pen Color Format (6 Pens).....	B-14
B.6	Connecting Analyzer to an Instrument Controller	B-15

Index

8003 Precision Scalar Analyzer Index	Index-1
--	---------

Illustrations

Figure 1-1:	Power Line Connection	1-2
Figure 1-2:	Operating Voltage Selection	1-4
Figure 1-3:	Uncertainty Due to Instrument Linearity & Zero Set vs. Input Power	1-9
Figure 1-4:	Reflection Uncertainty Relative to Directivity	1-10
Figure 1-5:	Reflection Uncertainty Relative to Source Match	1-10
Figure 2-1:	8003 Front & Rear Panel Components	2-2
Figure 2-2:	Display Screen Information Locations	2-8
Figure 2-3:	Typical Channel Summary Indications	2-10
Figure 2-4:	8003 Front Panel Controls	2-12
Figure 2-5:	Channel Control Menus Access w/ DEFINE Key	2-17
Figure 2-6:	Function Menus Accessed with the MEAS & SCALE Keys	2-18
Figure 2-7:	Function Menus Accessed with the DISPLAY Key	2-26
Figure 2-8:	PLOT ALL Function Hardcopy Printout (Typical)	2-27
Figure 2-9:	PLOT 4 Function Hardcopy Printout	2-28
Figure 2-10:	SC P1P2 Function Screen Hardcopy Printout	2-29
Figure 2-11:	Function Menus Accessed with the CAL Key	2-36
Figure 2-12:	Function Menus Accessed with the CURSOR & MEMORY Keys	2-42
Figure 2-13:	Softkey Menu Change from Frequency Change Prompt	2-52
Figure 2-14:	Stop Key Softkey Menu Prompt	2-53
Figure 2-15:	Power Softkey Menu Prompt	2-54
Figure 2-16:	System Control Menus Accessed with CONFIG Key (Part 1)	2-58
Figure 2-17:	System Control Menus Accessed with the CONFIG Key (Part 2)	2-59
Figure 2-18:	Analyzer, Sweeper, Sensor & Bridge Interconnection	2-66
Figure 2-19:	CAL Softkey Menu	2-67
Figure 2-20:	Sensor CAL Menu	2-67
Figure 2-21:	Sensor Calibration Display Screen	2-68
Figure 2-22:	New Frequency Parameters Display Screen	2-69
Figure 2-23:	Autoscaled thru Path Before Path Calibration Display	2-70
Figure 2-24:	THRU PATH Calibration Menu	2-71
Figure 2-25:	Calibrated Path Display	2-72
Figure 2-26:	Successful SHORT/OPEN CAL Display w/ Open Attached	2-73
Figure 2-27:	Device Measurement Plot (Typical Display)	2-74
Figure 2-28:	Cursor Plot Typical Display	2-74
Figure 2-29:	Swept Source & Power Sensor Only Block Diagram (w/ DUT)	2-75
Figure 2-30:	More Accurate Insertion Loss Ratioing Meas. (Back-to-Back Adpts. Improving Source Match)	2-76
Figure 2-31:	Two Sensor Insertion Loss Setup w/ a Power Splitter	2-77
Figure 2-32:	Two Sensor Insertion Loss using a Directional Coupler	2-77
Figure 2-33:	Return Loss Setup Using a Bridge	2-79
Figure 2-34:	Return Loss Test Setup Using a Directional Coupler	2-80
Figure 2-35:	Two Sensor Return Loss Setup Block Diagram	2-81
Figure 2-36:	Three Sensor Configuration Block Diagram	2-82
Figure 2-37:	“Golden Standard” Precision 20 dB Attenuator Measurement Using 20 dB Attenuator Reference	2-83
Figure 2-38:	Device Gross Characteristics (Filter Skirt) Display	2-84
Figure 2-39:	Device Fine Characteristics (Filter Pass Band) Display	2-84
Figure 2-40:	SCALE Display & Softkey Menu Typical Display	2-85
Figure 2-41:	REF → CURSOR Function puts Local Maximum Reference Point at the Reference Point for Easy Scale Factor Expansion	2-86
Figure 2-42:	Typical Measurement (Cursors, Delta Cursors & Markers)	2-87
Figure 2-43:	MAX Search Finds Minimum Return Loss of a Filter (Passband)	2-88
Figure 2-44:	MIN Search Finds Max. Insertion Loss Point (20 dB Fixed Attenuator)	2-88
Figure 2-45:	-3 dB Point (Low Pass Filter) at 3.175 GHz	2-89
Figure 2-46:	-30 dB Point (High Pass Filter)	2-90
Figure 2-47:	Automatic Bandwidth Movement (Very Narrow Bandpass Filter)	2-91
Figure 2-48:	Cursor Delta Indicates Relative Level & Frequency (Next Worse Return Loss Point)	2-92
Figure 2-49:	Cursors (Each Channel) Tied to Same Frequency Help Finding the 1 dB Compression Point on an Amplifier	2-93
Figure 2-50:	Filter Passband (Tuned Until Amplitude is -0.5 dB at the Marker)	2-94
Figure 2-51:	Sensor Calibration Screen	2-95
Figure 2-52:	Sensor ID Table	2-96
Figure 2-53:	Sensor CAL Factor Table	2-96
Figure 2-54:	8003 Swept Power Measurements with CAL Factor Correction	2-97
Figure 2-55:	CW Readings (All 3 Sensor Inputs Plus Ratio)	2-98

Figure 2-56: 3 Different Methods (CAL Factor Correction Plus Sensor Offsets)2-99
Figure 2-57: Averaging Used to Reduce Noise2-100
Figure 2-58: Reference Level & Corresponding Relative Reading.....2-101
Figure 2-59: Menus & Typical Display (Power Sweep Measurements)2-104
Figure 3-1: Location of GPIB/System Connection (Rear Panel).....3-1
Figure 3-2: GPIB Commands (Front)3-8
Figure 3-3: GPIB Commands (Back).....3-9
Figure 3-4: Plot Obtained Using More Complex HP Series 300 Prg. Example.....3-28
Figure 3-5: Limit Line Display Example3-63
Figure 4-1: Calibrator Output Test Setup4-3
Figure 4-2: Power Linearity Test Setup4-7

Tables

Table 3-1:	Definition of ASCII Codes	3-26
Table 4-1:	Test Equipment Required.....	4-2
Table A-1:	Power Sensor Selection Guide	A-2
Table A-2:	Power Sensor Cal Uncertainties	A-3
Table A-3:	Directional Bridge Selection Guide	A-4
Table B-1:	8003 Default Settings	B-1

About This Manual

This operation manual covers the Giga-tronics 8003 Precision Scalar Analyzer:

Preface:

In addition to a comprehensive Table of Contents and general information about the manual, the Preface also contains a record of changes made to the manual since its publication, and a description of Special Configurations. If you have ordered a user-specific manual, please refer to page xv for a description of the special configuration.

Chapters

1 - Introduction:

This chapter provides a brief introduction to the instrument and its performance parameters.

2 - Operation:

This chapter is a guide to the instrument's front and rear panel keys, display and configuration menus.

3 - Remote Operation:

This chapter provides how to operate the instrument from a remote location over the General Purpose Interface Bus (GPIB). All programming codes are presented in this chapter with various applications to aid you in understanding the operation.

4 - Performance Test & Calibration:

This chapter provides the procedures to verify the performance of the 8003 Precision Scalar Analyzer.

Appendices

A - Power Sensors:

This appendix provides selection data, specifications, and calibration procedures for power sensors.

B - System Configuration:

This appendix contains the 8003 default function parameters, it also contains instructions for common test equipment and the initial 8003 printer installation directions for its ability to generate displayed data/plot hardcopies.

Index:

A word index of the various elements of the 8003 manual.

Changes that occur after publication of the manual, and Special Configuration data will be inserted as loose pages in the manual binder. Please insert and/or replace the indicated pages as detailed in the Technical Publication Change Instructions included with new and replacement pages.

Conventions

The following conventions are used in this product manual. Additional conventions not included here will be defined at the time of usage.

Warning

WARNING

The **WARNING** statement is encased in gray and centered in the page. This calls attention to a situation, or an operating or maintenance procedure, or practice, which if not strictly corrected or observed, could result in injury or death of personnel. An example is the proximity of high voltage.

Caution

CAUTION

The **CAUTION** statement is enclosed with single lines and centered in the page. This calls attention to a situation, or an operating or maintenance procedure, or practice, which if not strictly corrected or observed, could result in temporary or permanent damage to the equipment, or loss of effectiveness.

Notes



NOTE: A *NOTE* Highlights or amplifies an essential operating or maintenance procedure, practice, condition or statement.

Record of Manual Changes

This table is provided for your convenience to maintain a permanent record of manual change data. Corrected replacement pages will be issued as Technical Publication Change Instructions, and will be inserted at the front of the binder. Remove the corresponding old pages, insert the new pages, and record the changes here.

Change Instruction Number	Change Instruction Date	Date Entered	Comments

Special Configurations

When the accompanying product has been configured for user-specific application(s), supplemental pages will be inserted at the front of the manual binder. Remove the indicated page(s) and replace it (them) with the furnished Special Configuration supplemental page(s).

Introduction

1.1 Description

The 8003 Precision Scalar Analyzer measures scalar (magnitude only) properties of microwave components. These properties include insertion characteristics (gain or attenuation) and reflection characteristics (return loss or VSWR). The 8003 offers a 90 dB dynamic range with a linearity of ± 0.04 dB in the CW Mode and ± 0.06 dB in the Swept Mode.

A unique feature of the 8003 is its ability to make CW power meter-accurate power measurements. Giga-tronics power sensors include EEPROMs programmed with Cal Factor data to give fully corrected power readings during frequency sweeps. A front panel calibrator linearizes sensors and bridges to ± 0.04 dB linearity, and provides an absolute power accuracy of $\pm 0.7\%$ at 1 mW. In essence, the 8003 can be used as an accurate 3-channel power meter.

1.1.1 Features

- Large full color display for easy viewing of traces and quick identification of channels
- Built-in sweeper control for automated setups and easier control of complex measurements
- Expert system menus that use color to help the operator quickly learn instrument operation
- Non-volatile memory to store functions such as path calibrations, user selected traces, and instrument states
- Full CW meter functionality including a large digital display mode, plus capabilities for including offsets, max and min hold, averaging, and ratio or difference measurements
- Full plot compatibility with most GPIB plotters and HP Laserjet series printers
- Fast CW Mode option over the GPIB
- Use with Triggerable Pulse (Peak Power) Sensors for swept peak measurements

1.2 Installation

The analyzer can be placed directly on a work bench or mounted in a 24-inch deep equipment rack by using the optional Y6001 or Y6002 Rack Mount Kit. Instructions for installing the 8003 with Rack Mount Kit are provided in the kit.

Allow at least 3-inches of clearance behind and on each side of the instrument for proper air circulation.

CAUTION

The following installation procedures must be completed before turning the instrument on for the first time, and whenever it is re-located or installed into a different system.

Select the correct operating voltage and install the proper fuse in this housing. Refer to Section 1.2.2, Line Voltage and Fuse Selection for instructions on how to select the voltage and replace the fuse. Observe the following Safety Precautions when installing the 8003. See Section 1.5 for connecting to the rear panel.

CAUTION

Do not connect main power to the unit until you have checked the required operating voltage and fuse rating. The instrument can be damaged if connected to a source voltage with the line voltage selector set incorrectly.

1.2.1 Safety Precautions

This 8003 has a 3-wire power cord with a 3-terminal polarized plug for connection to the power source and safety-ground. The ground (or safety ground) is connected directly to the chassis.

WARNING

If a 3-to-2 wire adapter is used, connect the ground lead from the adapter to earth ground. Failure to do this can cause the instrument to float above earth ground, posing a shock hazard.

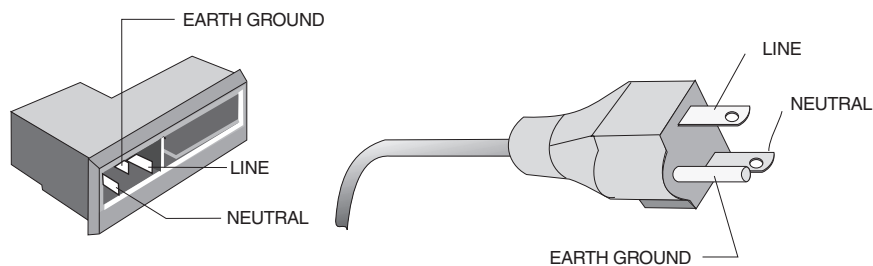

Figure 1-1: Power Line Connection

The 8003 is designed for international use with source voltages of 100, 120, 220, or 240 Vac, $\pm 10\%$ at 48 to 440 Hz. The 8003 uses an internationally approved connector that includes voltage selection, fuse, and filter for RFI protection.

1.2.1.1 Power Input, Fuse & Voltage Selector

The input voltage must be set to match the source at the location where the instrument is to be used. The number visible through the window on the selector card is the nominal line voltage to which the analyzer must be connected. See Section 1.2.4 for the power and fuse requirements, and procedures to select the voltage and to change the fuse.

CAUTION

Do not connect the ac power cord until you have confirmed that the input voltage has been properly selected and that the fuse for the ac input is correct.

1.2.2 Line Voltage & Fuse Selection

The instrument is shipped in an operational condition and no special installation procedures are required except to check and/or set the operating voltage and fuse selection as described in the following.

1.2.2.1 Power Sensors

The 8003 Series of Power Sensors are designed specifically for use with the 8003. The same sensors are used for both swept measurements and CW measurements. Both AC and DC detection modes can be used with any of the power sensors with the exception of the 80340 Series. Each sensor includes an EEPROM which has been programmed with Calibration Factor data for that specific sensor. General specifications for each sensor and calibration factor uncertainties are detailed in Appendix A.

1.2.2.2 Power Sensors Accessories

Each 8003 instrument is shipped with an adapter to interface power sensors with APC3.5(m) and Type K (m) connectors to the Type N (m) connector of the 8003's front panel Calibrator output. Adapters for sensors with APC7 connectors are optionally available.

1.2.3 Power Sensor Precautions

Power sensor safety precautions, selection, specifications, and calibration are detailed in Appendix A of this manual.

8003 Precision Scalar Analyzer

1.2.4 Power Requirements

100/120/220/240 Vac $\pm 10\%$, 48-440 Hz, 200 VA, typical.

The instrument is supplied with a three-conductor NEMA type power cord. For 100/120 Vac operation, the neutral conductor is white and the hot wire is black. For 200/240 Vac operation, both the white and black wires are hot. The green wire of the power cord is for connection to earth ground. The instrument will be properly grounded if the plug is connected to a properly installed three-prong receptacle. If a three-prong to two-prong adapter is used, be sure that the pigtail lead of the adapter is earth-grounded.

WARNING

The safety ground is connected directly to the chassis. If a 3-to-2 wire adapter is to be used, be sure to connect the ground lead from the adapter to earth ground. Failure to do this could cause the instrument to float above ground, posing a shock hazard to personnel.

The line voltages and fuse ratings are:

<u>Line Voltage</u>	<u>Fuse Rating</u>
100/120 Vac, $\pm 10\%$, 50, 60 or 400 Hz	3.0 AMP
220/240 Vac, $\pm 10\%$, 50, 60 or 400 Hz	1.5 AMP

CAUTION

Verify that the voltage setting and line fuse in the 8003 match the ac power source at your facility before connecting the line power cord.

The unit is set at the factory for operation at the normal supply voltage for the country in which it is sold. The input frequency must be 50, 60, or 400 Hz $\pm 5\%$. The combination of the module and transformer design allows instrument operation of 100/120 Vac (using a 3 Amp Slo-Blo fuse) or 220/240 Vac (using a 1.5 Amp Slo-Blo fuse), with an average power consumption of 100 VA. Conversion from one voltage to another can be made by changing the voltage selection PC board.

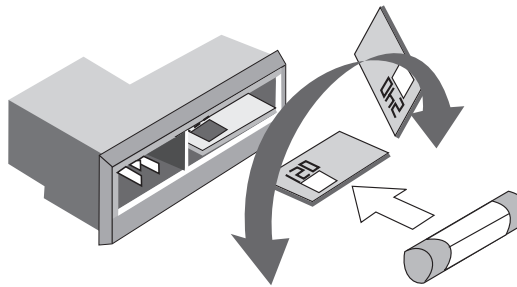

Operating voltage is shown in the module window

Figure 1-2: Operating Voltage Selection

To select a different operating line voltage and fuse, refer to Figure 1-2 and proceed as follows:



NOTE: *The analyzer may be furnished with the voltage selector and fuse holder described below, or the VDE-type fuse holder described in Section 1.2.4.2. Refer to the appropriate instructions for your analyzer.*

1.2.4.1 Standard Voltage Selector & Fuse Holder

1. Open the cover door, rotate the fuse-pull to the left, and remove the fuse.
2. Select the operating voltage by orienting the PC board so that the correct voltage label is on the top left side.
3. Push the board firmly back into the module slot.
4. Rotate the fuse-pull back into the normal position and reinsert the fuse into the holder. Use care to select the correct fuse value.

1.2.4.2 VDE Type Voltage Selector & Fuse Holder

1. Open the cover using a small screwdriver or similar tool and proceed as follows:
2. Use the same tool to remove the voltage selector (a small barrel-shaped component marked with voltage settings). Rotate the selector so that the desired voltage faces outward and place the selector back in its slot. Close the housing cover; the appropriate voltage should be visible through the window (see Figure 1-2).
3. With the housing cover open, pull out the small drawer on the right side of the housing (it's marked with an arrow) and remove the old fuse. Replace with a new fuse, insert the drawer and close the housing cover (see Figure 1-2).

1.2.5 Environmental Requirements

The 8003A instrument is type tested as follows:

- Operating temperature range is 0°C to 50°C (calibrator operating temperature range is 5°C to 35°C)
- Non-operating (storage) temperature range is -40°C to +70°C
- Relative humidity is limited to 95% non-condensing

1.2.6 Items Furnished

In addition to options and/or accessories specifically ordered, items furnished with the instrument are:

- 1 ea. - Power Cord
- 1 ea. - Model 8003 Network Analyzer & CW Power Meter
- 1 ea. - Operation Manual (P/N 20791)
- 3 Detachable sensor/bridge cables each (5 feet long)

8003 Precision Scalar Analyzer

1.2.7 Items Required

The 8003 requires an external power sensor; see Appendix A for Power Sensor Specifications.

1.2.8 Tools & Test Equipment

No special tools are required to operate the 8003.

1.2.9 Cooling

No cooling is required if the instrument is operated within its specified operating temperature range (0 to 50°C).

1.2.10 Cleaning

The front panel can be cleaned using a cloth dampened with a mild detergent; wipe off the detergent residue with a damp cloth and dry with a dry cloth. Solvents and abrasive cleaners should not be used.

1.2.11 Receiving Inspection

Use care in removing the instrument from the carton and check immediately for physical damage, such as bent or broken connectors on the front and rear panels, dents or scratches on the panels, broken extractor handles, etc. Check the shipping carton for evidence of physical damage and immediately report any damage to the shipping carrier.

Each Giga-tronics instrument must pass rigorous inspections and tests prior to shipment. Upon receipt, its performance should be verified to ensure that operation has not been impaired during shipment. Follow the installation instructions in Section 1.2 and the operating instructions in Chapters 2 or 3.

1.2.12 Preparation for Reshipment

Follow these instructions if it is necessary to return the product to the factory.

To protect the instrument during reshipment, use the best packaging materials available. If possible use the original shipping container. If this is not possible, a strong carton or a wooden box should be used. Wrap the instrument in heavy paper or plastic before placing it in the shipping container. Completely fill the areas on all sides of the instrument with packaging material. Take extra precautions to protect the front and rear panels.

Seal the package with strong tape or metal bands. Mark the outside of the package **"FRAGILE — DELICATE INSTRUMENT"**. If corresponding with the factory or local Giga-tronics sales office regarding reshipment, please reference the full model number and serial number. If the instrument is being reshipped for repair, enclose all available pertinent data regarding the problem that has been found.

 **NOTE:** If you are returning an instrument to Giga-tronics for service, first contact Customer Service so that a return authorization number (RMA) can be assigned via e-mail at repairs@gigatronics.com or at 800.444.2878 (The 800 number is only valid within the US). You may also try our domestic line at 925.328.4650 or Fax at 925.328.4702.

1.3 Specifications

The following are the specifications for the 8003.

System

Frequency Range:	10 MHz to 40 GHz in coax using Giga-tronics 803XXA Series power sensors and 80500 Series bridges and an appropriate sweeper (see the signal sources in Appendix A)
Power Range:	+30 to -70 dBm (see the Power Sensor specifications in Appendix A)

System Dynamic Range

CW Measurements:	90 dB
Swept Measurements:	AC Mode: 90 dB DC Mode: 80 dB
Peak Measurements:	40 dB
Inputs:	Three identical inputs, A, B and C accept detected outputs from Giga-tronics power sensors and bridges.

Display

CRT:	Full color display. Each channel can be assigned a different color. Graticule is selectable (default is green). Menus for the softkeys use color.
Display Resolution:	608 x 430 points for each channel.
Channels:	Four channels can be used to select and simultaneously display up to three inputs from A, B and C in single channel or ratio mode.

Graph/Readout Mode

Graph mode displays swept frequency response on the CRT. The Readout mode displays the power level at the cursor frequency or CW power levels in digital format on the CRT.

Graph Mode

Log:	dBm: Single channel power measurement.
	dB: Relative power measurement (ratio or relative to the trace memory).

ReadoutMode

Log:	dBm: Single channel power measurement.
	dB: Relative power measurement.
Linear:	nW, μ W, mW, and Watts: Single channel measurement
	%: Dual channel measurement.
	% Rel: Dual channel measurement relative to a device.

Display Mode	Display Scale Resolution	Display Range	Vertical Resolution
dBm/dB	0.1 to 20 dB/Div (1, 2, 5 sequence)	-99.99 to +99.99 dBm	0.01 dB

8003 Precision Scalar Analyzer

Channel Offset:	-90 to +90 dB in .01 dB increments.
Autoscale:	Automatically sets the scale factor, reference level, and reference position to provide an optimum display of the active channel.
Averaging:	2, 4, 8, 16, 32, 64, 128, or 256 successive traces (swept) or readings (CW) can be averaged to reduce the effects of noise on measurements.
Smoothing:	Provides a linear moving average of adjacent data points. The smoothing aperture defines the trace width (number of data points) to be averaged. The smoothing aperture can be set from 0.1% to 20% of the trace width.
Adaptive Path Calibration (Normalization):	Traces are stored in non-volatile memory and normalized with the highest resolution, independent of display scale/division or offset. 4096 points for each trace are stored over the full frequency range of the sweeper or any user-selected frequency range. Normalization data is automatically interpolated for ranges within the original normalized range.
Trace Memory:	Ten traces can be stored in non-volatile memory and recalled. Memory traces can be individually labeled. Stored traces can be displayed, and trace differences from any measurement can also be displayed.
Settings Store and Recall:	Allows up to nine full front panel setups plus a power-down last instrument state can be stored and recalled from non-volatile memory.
Limit Lines:	Horizontal, sloped, and/or single point lines for each trace can be set as go/no-go data limits. Limit lines are stored in non-volatile memory. Complex limit lines can be entered through the front panel or via GPIB interface.

1.3.1 Cursors & Markers

Cursor:	The cursor can be positioned with the tuning or via the numeric keypad. The frequency and amplitude of test data at the cursor on all active channels is digitally displayed.
Cursor Delta:	Displays the differences in dB and frequency between the reference cursor and the main cursor.
Cursor Min/Max:	Moves the cursor to the minimum or maximum value of test data.
Cursor x dB:	Moves the cursor to the point on the trace equal to the value of x in dB or dBm.
Cursor x Bandwidth:	Displays cursors to the right and left of the cursor at the frequencies where the test data is equal to the value of x dB. The bandwidth between the cursors is displayed.
Cursor Flatness:	Displays the difference in dB between the Max and Min values on the active channel.
Ref to Cursor:	Changes the Ref Level to the level at the cursor.
Markers:	Displays up to 10 markers generated by the 8003. The cursor can be moved directly to any marker or sequentially through the markers.

1.3.2 Accuracy

1.3.2.1 Transmission Loss or Gain Measurements

Transmission loss or gain measurements are made relative to a 0 dB reference point established during calibration. Therefore, frequency response errors of the source, sensors, and signal splitting device are removed. The remaining elements of uncertainty are instrument linearity and zero set uncertainty, see Figure 1-3, and mismatch error.

$$\text{Transmission Accuracy} = \text{Instrument Accuracy} + \text{Mismatch Uncertainty}$$

The low VSWR 8031XA series of sensors and the high power 8032XA series sensors have built-in attenuators. Therefore, the linearity at a particular power level must be modified to apply to the unattenuated sensor. Thus, for the 8031XA series which have a 6 dB attenuator, the linearity specifications will be for 6 dB more power than in the basic 8030XA Series of sensors. This is reflected in the scaling at the bottom of Figure 1-3.

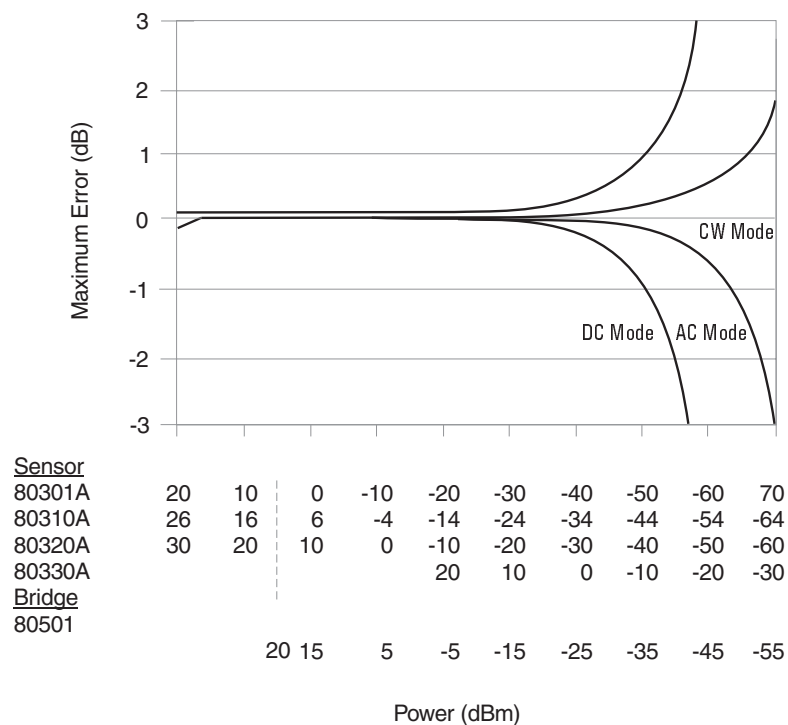

Figure 1-3: Uncertainty Due to Instrument Linearity & Zero Set vs. Input Power

1.3.2.2 Reflection Measurements

When measuring devices with high return loss (>10 dB), reflection accuracy is typically dominated by the effective system directivity, instrument linearity errors, and noise uncertainty. With low return loss devices (<10 dB), reflection accuracy is typically dominated by source match. Calibration with an open and short effectively removes uncertainties due to frequency response of the source, sensors, and signal splitting device.

Reflection Accuracy = Scalar Accuracy + Reflection Bridge Accuracy

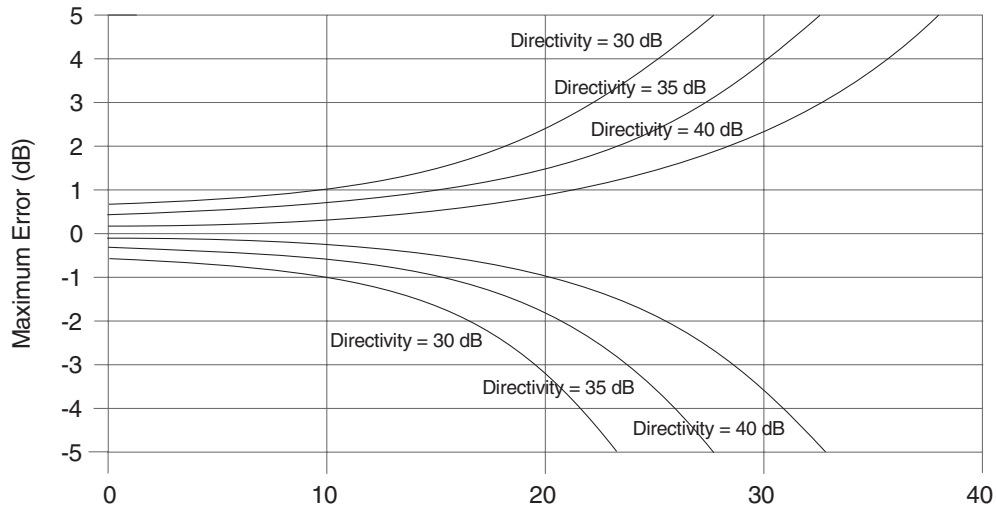

Figure 1-4: Reflection Uncertainty Relative to Directivity

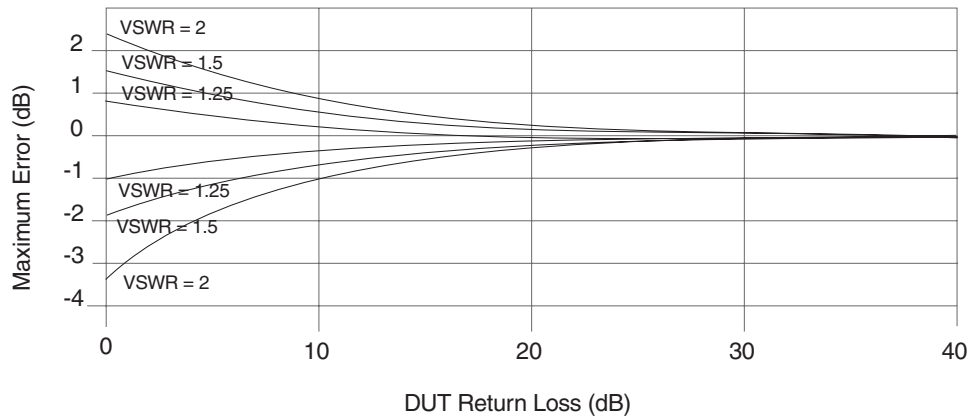

Figure 1-5: Reflection Uncertainty Relative to Source Match

1.3.2.3 Absolute Power Measurement Accuracy

The absolute power measurement accuracy is determined by a number of factors including calibrator accuracy, zero set error, noise, sensor calibration factor error, and the mismatch uncertainty between the sensor and the device under test.

Calibrator

Provides a 50 MHz calibration signal at 51 precise levels from +20 dBm to -30 dBm to dynamically linearize the sensors.

Frequency:	50 MHz, nominal
Settability:	The 0 dBm level in the power sweep is factory set to $\pm 0.7\%$ traceable to the National Institute of Standards and Technology (formerly NBS).
Connector:	Type N(f) connector, 50 ohm. (Adapters available for calibrating sensors with other connector types).
Accuracy:	$\pm 1.2\%$ worst case for one year, over a temperature range of 15°C to 35°C.
VSWR:	<1.05 (Return Loss >33 dB)

Instrument plus Power Sensor Linearity

Standard Sensors

CW Mode:	± 0.02 dB ($\pm 0.5\%$) over any 20 dB range from +16 to -70 dBm ± 0.02 dB + (+0 dB, -0.05 dB/dB) from +16 to +20 dBm ± 0.04 dB ($\pm 1.0\%$) from +16 to -70 dBm
Swept Mode:	± 0.03 dB ($\pm 0.7\%$) over any 20 dB range from +16 to -70 dBm ± 0.03 dB + (+0 dB, -0.05 dB/dB) from +16 to +20 dBm ± 0.06 dB ($\pm 1.4\%$) from +16 to -70 dBm
Low VSWR Sensors:	-64 to +20 dBm: Same as for Standard Sensors +20 to +26 dBm: Same as for Standard Sensors, plus an additional ± 0.13 dB (typically)
High Power Sensors:	-60 to +20 dBm: Same as for Standard Sensors +20 to +30 dBm: Same as for Standard Sensors, plus an additional ± 0.13 dB (typically)
True RMS Sensors:	
CW Mode:	± 0.02 dB ($\pm 0.5\%$) over any 20 dB range from +20 dBm to -30 dBm ± 0.04 dB ($\pm 1.0\%$) from +20 dBm to -30 dBm
Swept Mode:	± 0.03 dB ($\pm 0.7\%$) over any 20 dB range from +20 dBm to -30 dBm ± 0.06 dB ($\pm 1.4\%$) from +20 dBm to -30 dBm

Triggerable Pulse (Peak Power) Sensors

± 0.13 dB ($\pm 3\%$) from 0 to -30 dBm
± 0.13 (± 0.01 dB/dB) from 0 to +20 dBm

Temperature Coefficient of Linearity

<0.3%/°C temperature change after calibration

8003 Precision Scalar Analyzer

Zeroing Accuracy

(CW Mode, Averaging Factor = 32):

Zero Set:	±50 pW
Zero Drift:	Typically ±200 pW in 1 hour at constant temperature after a 24-hour warmup.

(Swept Mode, Averaging Factor = 32):

Zero Set:	±50 pW (AC Detection) ±800 pW (DC Detection)
Zero Drift:	Typically 2 nW (DC Detection) in 1 hour at constant temperature after a 24-hour warmup. Zero Drift not applicable in AC detection.

Noise Uncertainty

Typically <50 pW, at constant temperature, measured over a 1 minute interval, two standard deviations.

Cal Factor Correction

Manual or automatic correction to power readings to compensate for frequency response variations of the power sensors and bridges.

Manual:	Cal Factor, Cal Frequency, Off
Auto:	Sweeper

1.4 GPIB Interface

Interface

Operates according to IEEE 488.1 and IEC-625 interface standards. A private line GPIB is used to connect the analyzer to firmware supported sweepers.

Programmable Functions

All front panel functions except power on/off are programmable.

Interrupts

SRQs are generated for the following conditions:

- Power Up
- Front Panel key pressed
- Operation complete
- Illegal command
- Instrument self-test error
- Limit test failed

1.5 Rear Panel Inputs & Outputs

1.5.1 BNC Connectors

Sweep In

0 to +10V, nominal (Maximum = 10.75 V).

Blanking Input

Blank the sweep oscillator bandswitching points on the display

Voltage Level:	Blanked:	>2 V typical
(TTL)	Unblanked:	<0.8 V typical

V_{PROP}F Input

Interface to signal source V_{PROP}F output of -10 to +10 Vdc.

Input 1

Used with some sweepers to provide synchronization.

AC Modulation Output

Provides the drive to the modulation input on the sweeper, or to an external modulator, for use in the ac detection mode.

DAC Output

Not Currently Used.

Bias Output

Programmable output voltage used to display a family of curves.

Voltage Range: ±10 V

Current Compliance: Source or sink 150 mA, maximum.

1.5.2 GPIB Connectors

System GPIB

Used to connect the 8003 to a GPIB controller.

Private GPIB

Used to connects the 8003 to a signal source and plotter.

RS-232 Port

Serial Communication Interface for driving an HP Laserjet printer.

1.6 Signal Sources

1.6.1 System Integrated

The 8003 can be system integrated (sweeper control using the 8003) with the following sweepers:

- Giga-tronics 12720A
- Giga-tronics 7200 Series or 910 Series Synthesized Sweep Generators
- Giga-tronics 610 Series Sweep Oscillator
- HP8350A/B with an RF plug-in (HP86200 series with the HP11869A adapter)
- HP8340A/B, HP8341A/B or HP8360 Synthesized Sweepers
- Marconi 6300 Series Sweepers
- Wiltron 6600B Sweep Generators
- Wiltron 6700B Synthesized Sweep Generators

1.6.2 Operator Integrated

The 8003 is compatible with any signal source that meets the following requirements:

Horizontal Ramp:	Provides a 0 to +10 V nominal ramp signal.
Blanking Signal:	(Optional) Provides a TTL level during retrace and bandswitching.

1.6.3 Modulation

AC Detection Mode:	A square wave is provided by the analyzer to modulate the signal source.
Frequency:	1 kHz, nominal
On/Off Ratio:	>30 dB

1.7 General Specifications

Temperature Range

Operating:	0°C to 50°C (32° to 122°F)
Storage:	-40°C to 70°C (-40° to 158°F)

Power Requirements

100/120/220/240 Vac \pm 10%, 48 to 440 Hz, 200 VA typical

Physical Characteristics

Dimensions:	178 mm H x 451 mm W x 483 mm D (7.00 x 17.76 x 19.00 in)
Weight:	16.6 kg (36.5 lbs)

2.1 Introduction

This chapter describes how to operate the 8003 Precision Scalar Analyzer from its front and rear panels. Refer to Chapter 3 for instructions on how to operate the instrument from a remote host computer over the General Purpose Interface Bus (GPIB) or an RS-232 serial connection. Refer to Chapter 1 for instructions on how to install and interface the instrument before operating it for the first time. For purposes of greater reader visibility, the display screens will be shown in white and black, the product screens are naturally in a black background with color depictions as described in Section 2.3.1.

2.2 Front & Rear Panel Descriptions

This section describes the physical components of the 8003 Scalar Analyzer front and rear panels. Descriptions of the controls and components are referenced to the blocked numbers illustrated in Figure 2-1, and are described starting on page 2-3.

8003 Precision Scalar Analyzer

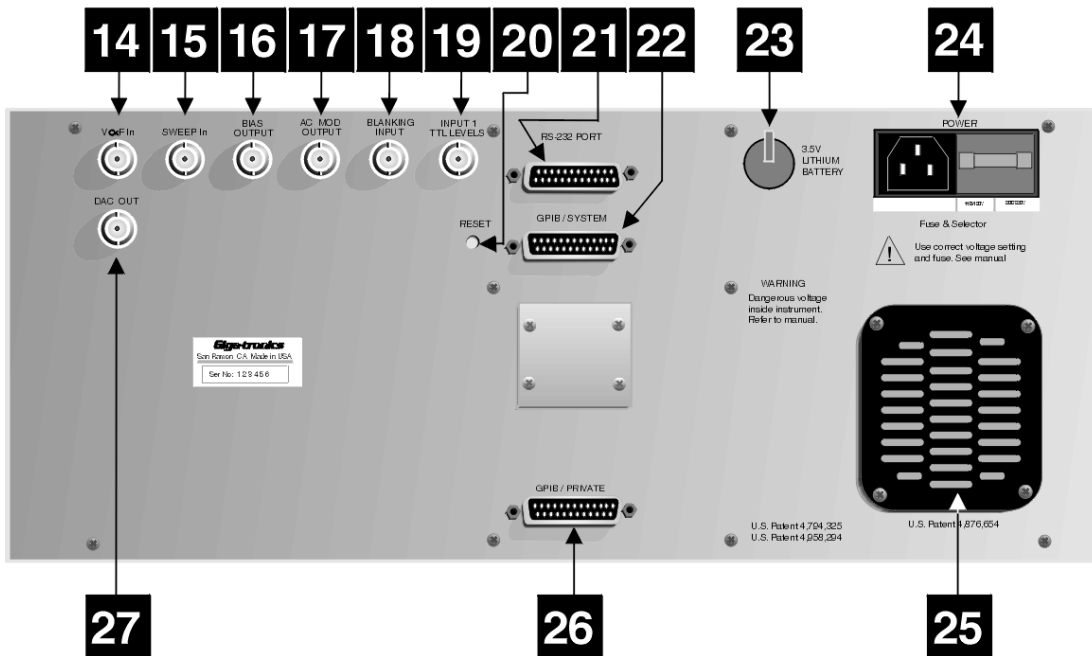
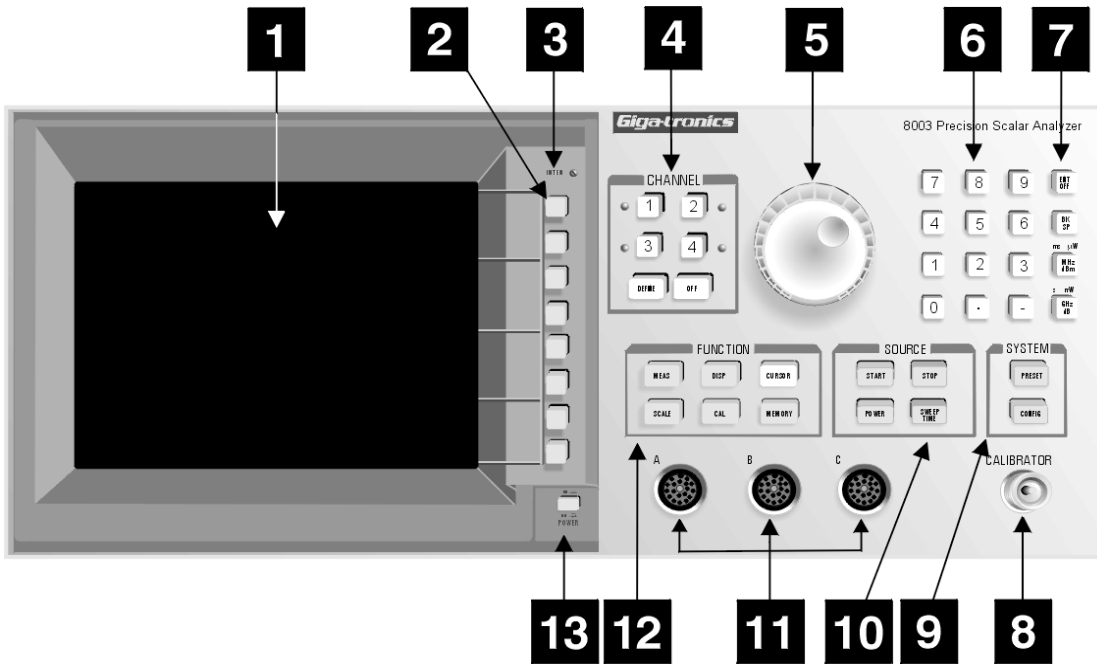

Figure 2-1: 8003 Front & Rear Panel Components

1 Display Screen

The Display Screen shows all of the channel characteristics, power readings, and trace information pertaining to any measurements that are taken. See Figure 2-2 and the display descriptions in Section 2.2.2 for an explanation of the information presented on the screen.

2 Softkeys

The eight softkeys select the control and functional options presented by the various menus (displayed on the screen) accessed through the Function, Channel, Source, and System keys located on the front panel. See the Functional Description in Section 2.3 for a complete discussion of all of the menu options accessible through these keys.

3 INTENSity Control

The Intensity control is a screwdriver adjustment to adjust the brightness of the display.

4 CHANNEL Control Keypad

Up to four channels can be selected to display power readings from any one, two, or all three of the sensors that are connected at the A, B, and C input receptacles.

The **[DEFINE]** key defines a few of the most basic characteristics of the measurement to be taken on the entry channel, and the **[OFF]** key turns off the entry channel. See Section 2.4 for a complete description of the use of these keys. LEDs located next to each numbered Channel Control key illuminate to indicate active, selected channels.

Throughout this manual, a distinction will be made between the front panel hardkeys and the adjacent CRT displays softkeys when their names are used in textual descriptions. The hardkeys are enclosed in brackets (as in **[DEFINE]** and **[OFF]** in the above paragraph), and the softkeys are shown in italics (for example, *SENSORS AC/DC*).

5 Spin Knob

The Spin Knob can access and adjust certain parameters as selected through the softkeys. The use of this knob will be defined in the various instructions given in this manual.

6 Numeric Entry Keypad

The Numeric Entry Keypad enters any desired or required numbers pertaining to the various parameters involved in setting up and taking measurements.

7 ENT/OFF, BK SP, and Units Keys

The **[ENT/OFF]** key enters any alphanumeric titles that might be assigned to specific measurement procedures. The **[BK SP]** key provides the means to back space when any titles are being entered. See Section for a description of the use of titles.

The **[MHz/dBm]** and **[GHz/dB]** keys select the units format in which it is desired to display any power readings.

8 CALIBRATOR

Attach the sensor to this connection to source the internal 50 MHz calibrator before taking any measurements. Sensors are calibrated across the range of -30 to +20 dBm, and the data is stored in the sensor EEPROM. See Section 2.8.1 for more information on calibration procedures.

9 SYSTEM Control Keypad

The **[CONFIG]** key of this keypad configures the 8003 and any other devices that might be interconnected on the 8003 private bus (see Section 2.7).

The **[PRESET]** key selects the default parameters for any currently displayed test parameters. See Appendix B for a list of default parameters.

10

SOURCE Control Keypad

The Source Control keys specify the various parameters that will be assigned to the power source being used for the measurement routine.

The **[START]** key initiates source frequency changes by specifying the desired start, center, or CW frequencies depending upon the mode of operation. The **[STOP]** key defines the upper limit of the frequency range of interest.

The **[POWER]** key allows the specification of the power level that the source will output, and the **[SWEEP TIME]** key sets the sweep time that is to be used for the measurement.

11

Sensor Input Connectors

These three receptacles, marked A, B and C, interconnect the sensor(s) that will be used for the measurement routine. One to three sensors can be used for insertion and return loss measurements. See Section 2.9 for a discussion of the usage of single or multiple sensor configurations.

12

FUNCTION Control Keypad

Control of the measurement functions of the 8003 is initiated by the six keys in this keypad. Each key, when pressed, will display a top level menu showing the measurement parameters that can be processed by using the sub-menu label options activated by the softkeys. Descriptions for all six keys can be found in Section 2.5.

The **[MEAS]** key accesses specific functions related to making ratio or comparison measurements with other selected measurements.

The **[SCALE]** key alters the parameters related to graphic presentations of measured data. These parameters include display scaling, reference level, and position.

The **[DISPLAY]** key controls the display and formatting of all measurements that are taken. A long series of sub-menus are available to use for precise control of all aspects of the display of measured data.

The **[CAL]** key activates the CAL menu which contains five different options used for path calibration, sensor calibration, and for zeroing sensors and bridges.

The **[CURSOR]** key accesses the cursor and marker capability of the 8003. Cursors and marker functions can be defined and turned on and off with this key.

The **[MEMORY]** key accesses the 8003 store and recall instrument setups. These setups are stored in non-volatile memory so that they will not be disturbed at power-down.

13

Power On/Off Switch

This is a push-push switch to control the ac power to the 8003. The ON condition is indicated by illumination of one or more of the Channel Indicator LEDs.

Rear Panel Description

Refer to Figure 2-1 for the illustrations of the rear panel. The functions are described below.

I/O Connections

14

$V_{\text{PROP}}F$ In

The $V_{\text{PROP}}F$ input can be connected to a signal source with a voltage output (between -10 and +10 Vdc) that is proportional to frequency. Then the measurement frequency is automatically determined by the analyzer. This input is especially useful under swept measurement conditions.

Microwave power sensors have a measurable frequency response. That is, the detector produces slight variations in I/O response with frequency. For this reason the frequency of operation should be entered when performing measurements.

15

SWEEP In

This input receives the horizontal deflection voltage (between 0 and 10.75 Vdc) generated by the sweeper to produce the proper positioning and trace information for the display. The circuitry is designed so that if the voltage should exceed 10.75 V, the excess will be clipped and not cause any damage.

16

BIAS Output

The bias output provides either biasing or operating voltage for some active external device. For example, you might apply it to a pin diode on which you want to check the attenuation at various bias levels, or it could be used to measure the input impedance on a modulator for which you are not sure.

The bias voltage is programmable from the front panel. It is generated by an internal amplified DAC in the range of -10 to +10 Vdc with up to 150 mA current capacity. The circuitry is protected by self-resetting, current-limiting devices (poly fuses). This means that if a short circuit should occur, the output would just stop supplying current until the short was cleared and cool down time allowed. No damage would be done.

17

AC Mod Output

The AC Mod Output modulates a sweeper when the scalar is operating in the ac mode. The output is the same as the bias output with the same current limiting protection.

18

BLANKING Input

The Blanking Input interfaces with the source to receive a TTL signal for blanking band-change switching points on multi-band sweepers.

19

INPUT 1 TTL Levels

The Input 1 TTL Levels connection provides the necessary synchronization to an internal log circuit of the 8003 when used with certain sweepers. For example, if a synthesized sweeper is being used, the TTL signal would tell the 8003 that the sweeper is locked, leveled, and that the signal was useful.

20

RESET Switch

This switch resets the 8003 to an initial power-on condition.

21

RS-232 Port

This is a standard serial port to drive printers or plotters to generate hardcopy of a screen or data information dump.

22

GPIB/System

This connection interfaces the 8003 to a remote controller when the instrument is to be remotely operated over the GPIB.

23

Lithium Battery

The 3.5 V lithium back-up battery powers the non-volatile memory when the instrument is turned off. The battery should be changed every six months.

24

POWER Input Connection

This is the receptacle for the ac mains power cable. Be sure that the instrument is set for the correct power as defined in Section 1.2.4.

25

Cooling Fan and Filter

The fan provides the air flow necessary to keep the instrument from overheating. Be sure that the filter is kept clean. A dirty filter can cause a thermal shutdown of the instrument in the middle of a test routine.

26

GPIB/PRIVATE

This is the interface connection for any external device (printer, plotter, etc.) that will be connected to the 8003.

27

DAC Out

The DAC Out connection was designed to provide an analog output at 0 to +10 Vdc from a separate, internal DAC. This function is not presently used.

2.2.1 GPIB Address Selection

Before the instrument can be remotely controlled over the interface bus, it must be assigned a specific address so that the controller can differentiate it from active bus components. This is accomplished with the following keystrokes:

1. Press **[CONFIG]** in the SYSTEM section of the front panel.
2. The menu that next appears will have a softkey labeled [*GPIB DEVICES*]. Press this key.
3. The display will then show the 8003 address and prompt to change the address. Enter any desired address (0 through 30) that is not currently being used for another device on the bus. The default address for the instrument is 4.

2.2.2 Display Description

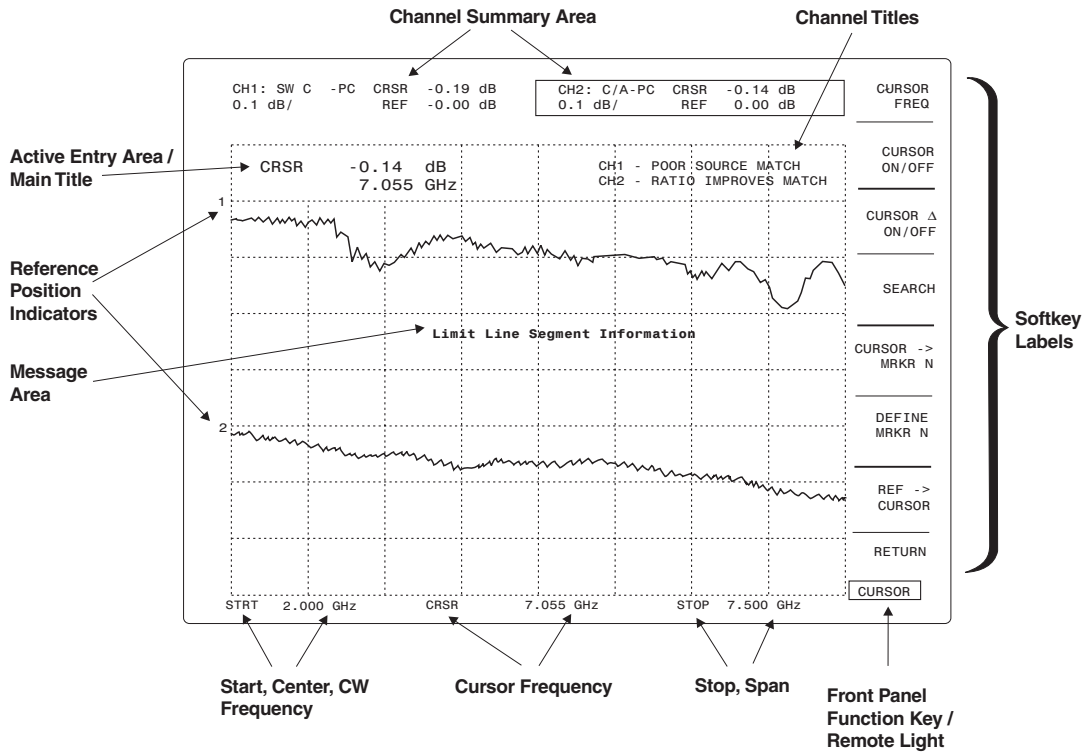

Figure 2-2: Display Screen Information Locations

Channel Titles

Displays the channels currently in use and any selected titles that have been assigned to them.

Softkey Labels

These labels show the measurement modification options available in the current functional mode. See Section 2.5 for a detailed description of all softkeys on pages 2-40 through 2-46.

Front Panel Function Key/Remote Light

This area displays which function key is currently in use or, if the instrument is under GPIB control, it will display REMOTE.

Stop, Span

Shows the upper limit of the selected frequency range.

Cursor Frequency

Shows the frequency selected for the cursor location on the display.

Start, Center, CW Frequency

Shows the frequency mode currently in use (STRT, CNTR, or CW), and the frequency selected to be used with that mode.

Reference Position Indication

This area shows the selected frequency reference point for each channel being displayed (channels 1 and 2 in Figure 2-2). The power level being used as reference is given in the REF section of each channel summary area.

Message Area

This area of the display shows any special messages pertaining to the current measurement.

Active Entry Area/Main Titles

Shows the function currently being used, and the most important parameters of interest associated with that function.

Channel Summary Area

The Channel Summary Area displays the parameters to be used with the designated channel for the current measurement. The front panel function keys are used initially to call up the desired menus which define these parameters. This means that each function key will define different parameters, causing different information to be displayed in the Summary Area depending on the function key being used.

8003 Precision Scalar Analyzer

Figure 2-3 shows some of the most commonly used parameters and their locations in the Summary Area. The text following the figure gives a brief description of the parameters and, where applicable, refers you to sections of the manual where complete definitions can be found.

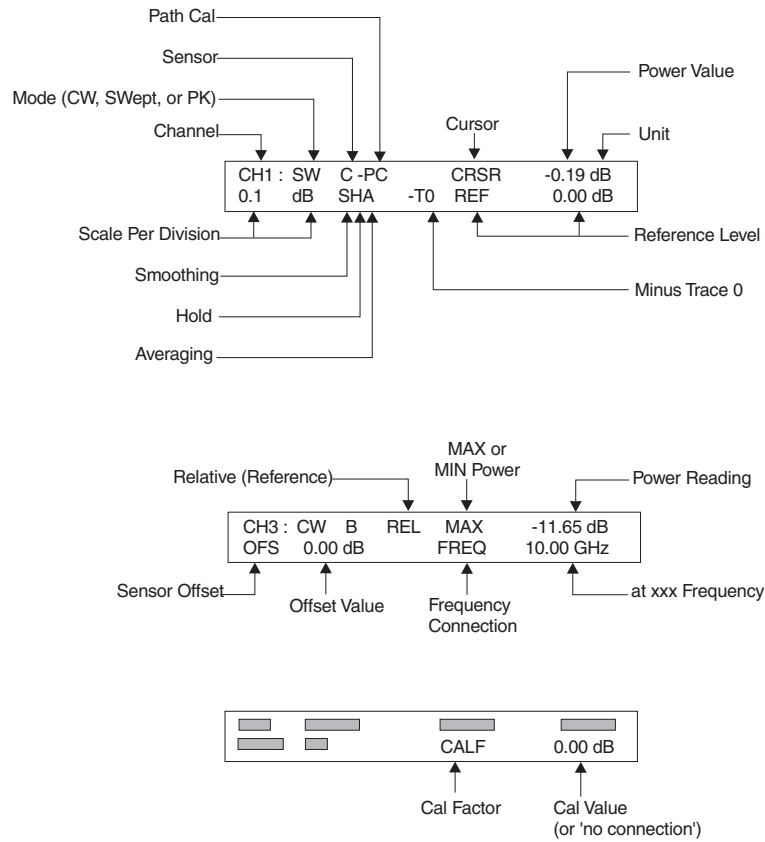

Figure 2-3: Typical Channel Summary Indications

The descriptions of the Channel Summary entries are as follows: (clockwise, top to bottom.)

Channel, Mode, and Sensor

These three items will always be present in the Summary Area. CH will be followed by 1, 2, 3, or 4 to indicate the channel number. SW, PK and CW show whether the swept, Peak or CW mode is in use, and A, B, or C indicates which sensor is assigned to the channel.

PATH CAL

This PC indication specifies that path calibration data is being subtracted from the swept measurement reading. See Section 2.8.2 for a complete description of the use of path calibration.

Cursor, Power Value, and Unit

Indicates the power value being read at the cursor location on the displayed trace. The reading can be in dB or mW units.

Reference Level

Indicates the value set for the Reference Position(s) of the trace displays for each displayed channel, as shown in Figure 2-3.

Minus Trace 0

Shows that a trace stored in memory (location 0 through 9) is being subtracted from the measurement.

Smoothing, Hold and Averaging

Display of any or all of the S, H, and/or A indications means that the displayed Smoothing, Hold, and/or Averaging function is active in the measurement. See Section 2.5 (page 2-24) for a description of how to use these functions.

Scale Per Division

Shows the vertical scale factor that has been selected for the current display (see Section 2.10).

Relative (Reference)

The Relative function does for CW readings what Path Cal does for swept readings. REL on the display shows that this mode is in use for the measurement. See Section 2.10 for use of the REL function).

MAX or MIN Power

Shows whether the [MAX] or [MIN] softkey has been selected to read either the maximum or minimum power at the cursor location.

Power Reading, at XXX Frequency

Displays the selected maximum or minimum power reading at the cursor location, and the frequency at which the reading is being taken.

Frequency Correction

Displays the specific frequency at which any Cal Factor corrections are being made. See Cal Factor below.

Sensor Offset, Offset Value

Displays any offset that has been applied to the indicated sensor to compensate for attenuators or amplifiers between the device under test and the sensor (see Section 2.12.3).

Cal Factor, Cal Value

Shows that a Cal Factor at the indicated value is in effect for the sensor (see Section 2.12 for Cal Factor discussion).

2.3 Softkey Functional Description

This is a detailed description of the functions for setting up and preparing to take measurements with the 8003. The 8003 is addressed and controlled by four groups of specific functional keys, eight softkeys for accessing menu options, a data entry key group, and a spin knob located on the front panel.

The functional keys are arranged in groups according to the general functions they control (see Figure 2-4 below). The Channel, Function, Source, and System key groups either allow the immediate entry of data or call up the display of main menus from which specific, related measurement parameters can be addressed. This is done by pressing one of the softkeys adjacent to the display screen to display sub-menus, which will further assist you in setting up precise measurement parameters.

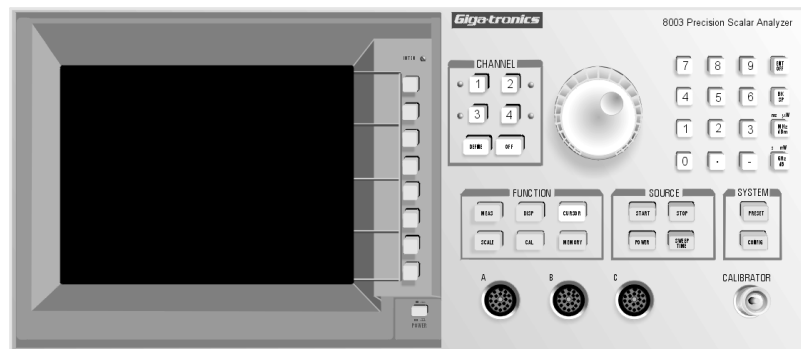

Figure 2-4: 8003 Front Panel Controls

2.3.1 Softkey Labels & Color Indications

The softkey menu labels are shown, where applicable, in three different colors. A green label indicates what happens if the corresponding key is pressed. A light blue label is the current, active state of the instrument. Dark blue labels indicate any options contained in the menu which are not available in the current state of the instrument.

2.3.2 Channel & Function Selection

The 8003 four-channel capability allows different types of measurements to be taken, processed, and displayed. You define the desired measurement to occur on a specified channel. Having multiple channels then allows you to define multiple measurements to occur simultaneously without regard to which sensors the channels are using. Two or more channels can share the same sensor. This is possible because power is all the 8003 will actually measure from the sensors.

You can change a parameter for all channels without leaving the menu. Just a single keystroke is required to change entry channels without bringing up a channel menu. For instance, suppose the scale factor for one channel has been entered. To enter the scale factor for another channel, just press the appropriate channel selection key. The scale factor menu will stay on the screen and the scale factor for the newly selected channel can now be entered.

2.3.3 Sensors & Sensor Calibration

The 8003 automatic calibration system allows its sensors to function as essentially perfect linear power sensors. Each power sensor stores its serial number as well as frequency correction information in an EEPROM in the sensor head. Combined, these features allow the 8003 to take absolute power measurements and function as a CW power meter as well as a scalar network analyzer.

The 8003 cannot take measurements with uncalibrated or disconnected sensors. A measurement that uses an unavailable sensor will not be able to be specified. Softkey labels referring to a measurement on an unavailable sensor will be in dim, dark blue. For example, if sensor C were uncalibrated or not connected it would not be possible to zero sensor C, perform a path calibration involving sensor C, or define any of the following measurements on the entry channel: C, A/C, B/C, C/A, C/B, A-C, B-C, C-A, or C-B.

2.3.4 Absolute Power & Swept Capabilities

The absolute power measurement capability of the 8003 allows the instrument to make swept absolute power measurements which can be graphically displayed and manipulated. This capability also allows the 8003 to function as a CW power meter.

Any channel can be designated to take either swept or CW measurements. In this context, swept refers to swept measurements meant to be plotted in graphic format. CW measurements will only be displayed in character format in the channel summary area of the display screen.

Some of the swept measurements are not available in the CW mode and vice versa. As an example, no cursor options are available in the CW mode. Therefore, if the entry channel is in the CW mode and the cursor key is pressed, the softkey menu labels will change to the cursor key menu, but all the labels will be dim, dark blue. If any of the softkeys are pressed, no action will occur. Another example is that sensor difference measurements will not be available for swept measurements.

2.3.5 Graph & Readout Display Modes

There are times when a large numeric readout is more convenient than a graph. Because of this, the 8003 has two major display modes. One of these is the graphic display mode in which swept channel measurements are graphically displayed. Summary information for swept measurements is displayed in the channel summary information area. CW channel measurements cannot be displayed graphically but can be displayed in the channel summary area.

The other display mode is data readout display. In the data readout mode, the results of CW channel measurements are displayed in large characters in the middle of the display screen. There is no graphic representation of data. Swept channel measurements have only their channel summary information displayed in large characters.

2.3.6 Path Calibration Memory

Besides absolute, swept, and CW power measurements, the 8003 can make normalized measurements. A normalized measurement is displayed relative to a path calibration made without the device under test. In the 8003, each sensor has its own path calibration memory. There is also unrelated non-volatile memory which can store measurement trace data from any channel for use on the same and/or any other channel(s).

A path calibration will be performed when the instrument is commanded to perform a through path calibration or a short/open path calibration. Path calibrations will be performed only for individual sensors, one at a time. The path calibrations will be performed and stored by sensor, not by channel.

The 8003 allows the definition, by channel, of whether or not to use path calibrations. If it is specified that path calibrations should be used on a channel, then the measurement of each sensor being used by the channel is ratio'ed with its path calibration. If a sensor's path calibration has been cleared, then the use of the path calibration will have no effect on the sensor's measurement.

8003 Precision Scalar Analyzer

When path calibration is used, the 8003 does not apply Cal Factors to the readings. Cal Factors are only useful for absolute power measurements. Any Cal Factor correction would be canceled when making relative measurements.

To make the path calibration over wide frequency ranges useful, the 8003 memorizes a very large number of data points (up to 4096) during a path calibration. With such a high resolution of data points, the 8003 is able to maintain a very high level of accuracy within any sub-range of the frequency range of the path calibration.

Any path calibration can be cleared at any time during instrument operation. When a path calibration is cleared, it is initialized to 0 dBm so that it will have no effect if it were ratio'ed with any measurements.

2.3.7 Trace Memory

The 8003 can store measurement data of up to ten traces in non-volatile memory. The traces are stored and used by number. The traces can be stored by any channel and they, in turn, can be used by any channel. The measurement can be specified on any desired channel to be the ratio of the current measurement data and the trace n measurement data, where n is between 0 and 9 inclusive. Traces are memorized as 512 points along the frequency axis.

A title can be specified for each stored trace. This allows you to specify in your own words what the memorized trace data represents. When a measurement is being ratio'ed with a memorized trace, the title of the trace memory replaces the channel title. Memorized traces can be displayed as a channel for comparison to a current measurement.

A memorized trace can be deleted by clearing all of the memory of the 8003, by clearing specified memorized traces, or by clearing all memorized traces. When a memorized trace is cleared, it will be replaced with a 0 dBm trace, so that it would have no effect if it were inadvertently ratio'ed with a measurement trace.

2.3.8 Power On

When the 8003 is powered on, the instrument will restore itself to the same configuration it was in at power off. This will include restoring the menu which was being displayed at power off and the path calibrations at the time power was turned off. The only aspects of the instrument operation which will not be restored will be the measurement data at the time power is turned off.

2.4 CHANNEL Controls

The 8003 has four channels. The measurements to be made on each channel, including the sensor(s) to make the measurement, can be independently specified. Any number of channels, 1 through 4, can be on at the same time.

When a Channel number key is pressed, that channel becomes the entry channel. If a Channel key is pressed and the channel is off (not taking measurements or displaying data), then the channel is turned on and becomes the entry channel. When a channel becomes the entry channel, the previous entry channel remains on but will no longer be the entry channel.

2.4.1 OFF Key

[OFF]

The CHANNEL **[OFF]** key turns off the entry channel. This suspends the taking of data and the display of the channel but does not change any of the entry channel settings. When the channel is turned back on, it will be the same as it was before.

When the entry channel is turned off, the most recent entry channel that has not been turned off will become the entry channel. There must always be an active channel. If only one channel is on, it cannot be turned off.

2.4.2 DEFINE Key

[DEFINE]

The CHANNEL **[DEFINE]** key defines some of the most basic characteristics of the measurement on the entry channel. When **[DEFINE]** is pressed, the softkey menu structure shown in Figure 2-5 will be entered. Each of the primary functions of the Define first level menu (labeled C1) will be discussed in the following.

[SINGLE SENSOR]

Menu C1: Allows you to define the active channel to measure power from a single sensor only. Pressing the **[SINGLE SENSOR]** softkey (when it is not in dim, dark blue) brings up sub-menu C1-1.

[A], [B], or [C]

Menu C1-1: Refers to the three sensor inputs. Pressing **[A]**, **[B]**, or **[C]** that is not in dim, dark blue causes the entry channel to begin taking measurements on the indicated sensor.

[RATIO]

Menu C1: Allows you to define the active channel to measure the power ratio of any two sensors. Pressing **[RATIO]** brings up menu C1-2.

[A/], [B/], [C/]

Menu C1-2: Selects the numerator of the desired power ratio measurement. Selecting the numerator leads to menus C1-3, C1-4, or C1-5 where the denominator is chosen.

[DIFF]

Menu C1: Accesses the differential measurement capability of the 8003. This feature is usable only for channels in the CW mode, and would cause all softkey labels to revert to dim, dark blue if the routine were changed from the CW to the swept mode at any point while the DIFF softkey menus were in use.

[A-], [B-], [C-]

Menu C1-6: Selects the channel that is to be the minuend for a differential comparison. Selecting the minuend leads to menus C1-7, C1-8, or C1-9 where the subtrahend is chosen.

[CW/SWEPT]

Menu C1: Toggles the routine between CW or swept measurements on the entry channel. These two modes operate similar in some ways and very different in other ways.

Averaging is an example of a parameter used in both the CW and Swept Modes. Averaging does not change when switching from one mode to the other. Whatever averaging number is set for one mode will be carried over into the other.

Only the swept mode makes use of path calibrations or memorized traces. Therefore, regardless of whether or not these features are being used in the swept mode, when a channel is changed to CW mode it automatically reverts to displaying only the sensor absolute power measurement or ratio of absolute power measurements if a channel has been defined to measure a ratio. However, when the channel is changed back into the swept mode the instrument will remember whether or not the channel was using path calibrations or a memorized trace when it was previously in the swept mode, and revert to the same state again.

The entry channel can be placed into either the CW or swept mode at almost any time. An exception would be when the channel is in the CW mode and displaying the difference between sensor measurements. A difference between sensor measurements can only be displayed in the CW mode. Therefore, a channel cannot be changed from the CW to the swept mode while it displaying the difference between sensor measurements.

Another instance where it is not possible to freely change between the CW and swept modes is when the entry channel is in the swept mode and displaying a memorized trace, since memorized traces have no meaning in the CW mode.

See Section 2.3.4 for a discussion of the differences between CW and swept modes.

[BIAS VOLTAGE]

Menu C1: Sets the output voltage from the BNC connection on the rear panel during the sweep time of each active (ON) channel. Up to four different bias voltages can be selected. To set the bias voltage, first select a channel (1, 2, 3, or 4). Then enter the desired bias voltage using either the spin knob or the numeric entry keypad. Range of bias voltages is 10 V in 1mV steps.



NOTE: *The shaded labels at the bottom of each menu (C1, C1-1, C1-2, etc.) are only for reference to avoid confusion during this discussion. They have no relationship to the physical operation of the instrument.*

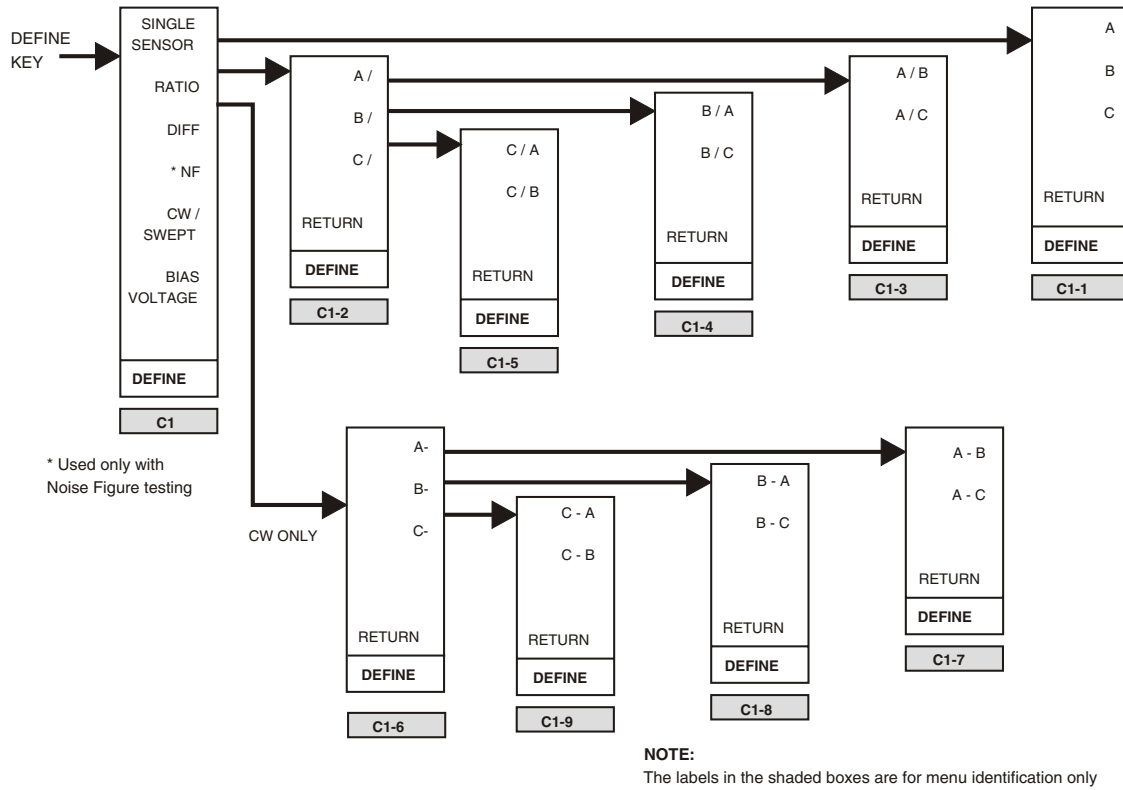

Figure 2-5: Channel Control Menus Access w/ DEFINE Key

2.5 FUNCTION Controls

The major functions of the 8003 are controlled by the six FUNCTION keys. These keys access the measurement functions of the instrument and change measurement parameters when required. Each of the primary functions and the menus and sub-menus accessible by these six keys are described in this section.

2.5.1 MEAS Key

[MEAS]

The FUNCTION **[MEAS]** key accesses specific functions related to making ratio or comparison measurements with other selected measurements. When **[MEAS]** is pressed, softkey menu F1 shown in Figure 2-6 will be displayed.

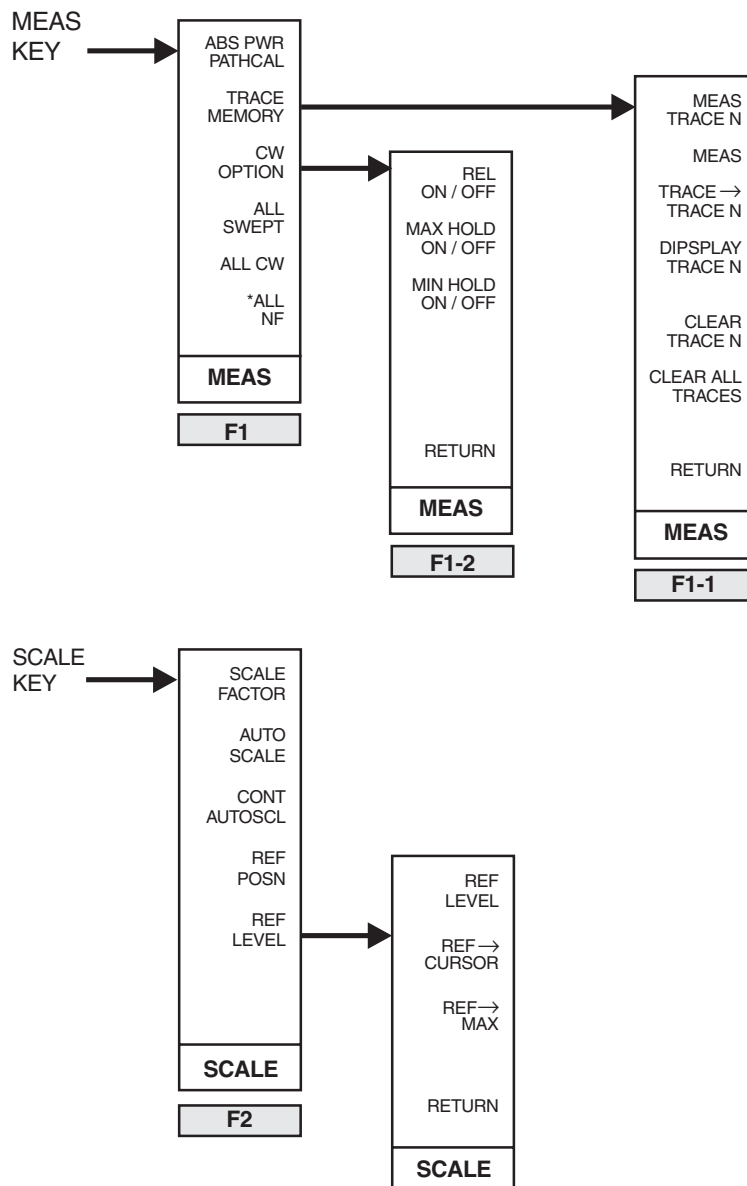

Figure 2-6: Function Menus Accessed with the MEAS & SCALE Keys

[ABS PWR PATHCAL]

Menu F1: Toggles between absolute power measurements using Cal Factors, and relative measurements that are being ratio'ed with a stored path cal.

When the Absolute Power measurement mode is active (ABSPWR shown on the menu in light blue), the instrument applies a Cal Factor to each reading. All power readings are displayed in absolute power units (dBm or Watts) unless the ratio of two sensors is being measured.

When Path Calibrations are used (PTH CAL shown on the menu in light blue), measurements are ratio'ed to a stored path calibration. Cal Factors are not used.

Path calibrations can be used only when making swept measurements. If the entry channel is measuring in the CW mode, the [ABS PWR/PATH CAL] softkey label will be in dim, dark blue and the sensor path calibrations will have no effect on the CW measurements.

[TRACE MEMORY]

Menu F1: Accesses stored measurement traces. The entry channel current measurement trace can be stored, the current measurement trace can be replaced with a stored trace, or the channel current trace can be ratio'ed with a stored trace. This feature is available only when making swept measurements.

When [TRACE MEMORY] is pressed, the softkey menu will change to menu F1-1.

[MEAS-TRACE N]

Menu F1-1: Allows you to specify any memorized trace that you wish to ratio with the current trace.

The entry area of the display will present a prompt to enter the memory location number (0 - 9) of the stored trace to be ratio'ed with the current measurement trace. A memorized trace can only be entered through the keypad, not by the spin knob. When a UNITS key (MHz dBm or GHz dB) is pressed, the measurement will ratio the current measurement trace with the specified memorized trace.

The current measurement trace of any channel can be ratio'ed to only one memorized trace. If the current measurement trace is being ratio'ed to one memorized trace and another memorized trace is specified, then the current trace will be ratio'ed only to the last specified memorized trace. Meas Trace x - Meas Trace y cannot be defined.

[MEAS]

Menu F1-1: Causes the entry channel to display its current measurement ratio'ed with or without path calibration(s) as indicated, but not with any memorized traces.

[TRACE → TRACE N]

Menu F1-1: Memorizes the current measurement trace as Trace N. When this softkey is pressed, a prompt will appear in the entry area of the display to remind the user to enter the trace number under which the trace will be stored. When a UNITS key is pressed, the trace will be stored in non-volatile memory. The entry area of the display will then indicate that the trace was stored.

8003 Precision Scalar Analyzer

If a trace is memorized as trace n, whatever trace was previously memorized as trace n will be overwritten and cannot be retrieved. However, the title of the memorized trace is not affected by the memorization of a new trace.

[DISPLAY TRACE N]

Menu F1-1: Presents a prompt to enter the number of the trace in memory that it is desired to examine. When a UNITS key is pressed, the specified memorized trace will replace the entry channel measurement trace. The memorized trace title will replace the title of the entry channel (when the channel title has been turned on).

[CLEAR TRACE N]

Menu F1-1: Clears a memorized trace. When a memorized trace is cleared, it is replaced with a 0 dBm trace so that it will have no effect if ratio'ed with a measurement trace. The title of the memorized trace will also be cleared.

When a number is entered, the memorized trace is cleared and the entry area of the display will indicate that the operation was completed.



NOTE: A trace cannot be restored once it is cleared.

[CLR ALL TRACES]

Menu F1-1: Clears all of the memorized traces. When a memorized trace is cleared, it is replaced with a 0 dBm trace so that it will have no effect if ratio'ed with a measurement trace. The titles of the memorized trace will also be cleared. (See the Trace Memory description on page 2-19).

When [CLR ALL TRACES] is pressed, the entry area of the display will show the prompt:

CONFIRM TO CLEAR

The softkey menu will present the option of either clearing all traces or to abort the clearing function. When [CLR ALL TRACES] is pressed a second time, all memorized traces will be cleared. The entry area of the display will indicate that the traces have been cleared and the instrument will return to menu F1.



NOTE: This action cannot be reversed once accomplished. Cleared traces cannot be restored.

[CW OPTION]

Menu F1: Accesses certain measurement functions which can be taken only when in the CW mode.

[REL ON/OFF]

Menu F1-2: Accesses the CW Relative measurement mode. When this softkey is pressed to initiate the relative mode, the CW measurement on the entry channel is memorized and all future measurements on that channel are made relative to the memorized measurement. This means that all future measurements will be linearly ratio'ed with the memorized measurement. When the entry channel is in the relative mode, this softkey will turn off the relative mode.

If the measurement is in logarithmic units (see the UNITS softkey description on page 2-32), the reading will be displayed in dB. If the measurement is in linear units, the reading will be displayed in percentage.

[MAXHOLD] and [MINHOLD ON/OFF]

Menu F1-2: When either the [MAXHOLD ON/OFF] or [MINHOLD ON/OFF] softkeys is pressed, the CW measurement on the entry channel is memorized and displayed as the maximum or minimum measurement. All future measurements on that channel are then compared with the memorized measurement. If the new measurement is greater than or less than the memorized measurement, the new measurement is memorized and displayed as the new maximum or minimum measurement. As this implies that after the maxhold or minhold modes are turned on, only the maximum or minimum measurement, as appropriate, will be displayed.

[ALL SWEPT] and [ALL CW]

Menu F1: The [ALL SWEPT] and [ALL CW] softkeys specify whether all four channels (or whatever channels are currently active) will take measurements in either the Swept or the CW mode of operation.

2.5.2 SCALE Key

[SCALE]

The FUNCTION **[SCALE]** key alters the parameters related to the graphical presentation of the measured data. These parameters include display scaling, display reference level, and display position. Scaling functions are available only for swept measurements, and will be shown as unavailable (in dim, dark blue on the softkey menu display) if the active channel is in the CW mode.

[SCALE FACTOR]

Menu F2: Allows the setting of the scale factor for the active entry trace. It causes the entry area of the display to indicate the current scaling factor for the entry channel, and also presents a prompt to enter a new scaling factor, if required. If the entry channel is continuously autoscaling when this softkey is pressed, the channel will cease autoscaling and the last scale factor determined by the autoscaling will be the scale factor shown in the entry area of the display.

Scale factors can be either selected by the spin knob or entered through the numeric keypad. If numerically entered, the scale factor will always be rounded to the nearest allowable value. The allowable scale factors are: 0.1, 0.2, 0.5, 1, 2, 5, 10, and 20 dB/DIV.

[AUTOSCALE]

Menu F2: Causes the 8003 to autoscale the entry channel. Autoscale involves setting the scale factor, the reference level, and the reference position to display the entry channel main trace with the highest possible resolution while still fitting the entire trace on the display. When **[AUTOSCALE]** is pressed the 8003 autoscales the entry channel, the parameters are changed, the display adjusts, and the entry area displays the main trace scaling factor so that it can be changed, if desired.

[CONT AUTOSCL]

Menu F2: Causes the 8003 to begin continuously autoscaling the entry channel. Continuous autoscaling means that the routine will try to maintain the greatest resolution possible while still fitting the entire trace in the display. During every update of the channel's trace, the 8003 will internally autoscale the channel. The scaling that results from this autoscale will be compared with both the channel current scaling and the results from recent autoscales. Using hysteresis, the channel will gradually change the scaling on the channel as required.

[REF POS]

Menu F2: Sets the position of the reference line display graticule for the entry channel main trace. The current reference position is indicated by a small number, corresponding to the channel number, to the left of the grid. The reference position can only be changed by using the spin knob.

[REF LEVEL]

First Level Menu F3: Sets the power level corresponding to the reference line being used for the entry channel main trace. The reference level is the power level around which the channel main trace is scaled. As scaling changes, the points on the reference line which intersect the power trace will not change.

If [REF LEVEL] is pressed, it will cause the softkey menu to change to F2-1.

[REF LEVEL]

Second Level Menu F2-1: Allows automated setting of the reference level in addition to manual setting. The [REF LEVEL] softkey repeats the manual entry of the reference level as described previously.

[REF → CURSOR]

Menu F2-1: Automatically sets the reference level to the current cursor power level.

[REF → MAX]

Menu F2-1: Changes the entry channel reference power level to equal the maximum power level on the channel trace. The entry area of the display will show this new reference level and allow it to be changed as desired.

2.5.3 DISPLAY Key

[DISPLAY]

The FUNCTION **[DISPLAY]** key controls the display and formatting of all of the measurements that are taken. When **[DISPLAY]** is pressed, the softkey menu will be displayed as shown in F3 in Figure 2-7 on page 2-26.

[AVG]

Menu F3: Accesses the averaging sub-menu and allows the averaging factor for the entry channel to be changed.

Averaging reduces the amount of noise on a trace. The minimum amount of averaging should be selected to reduce noise to an acceptable level. This allows the trace to change while still controlling the noise.

When averaging is selected on a channel, it is indicated by the character **A**, which appears on the second line of the channel summary area of the CRT display.

[AVG M]

Menu F3-1: Selects the Averaging Mode and sets the averaging factor for the entry channel.

In the swept mode, the averaging function averages successive traces. The number of traces to be averaged can either be selected with the spin knob or entered through the numeric keypad. If entered through the keypad, the selected averaging number will always be rounded to the nearest allowable number. The allowable averaging numbers are: 1, 2, 4, 8, 16, 32, 64, 128, and 256 traces. In the CW mode, averaging works exactly the same way except that successive CW power readings instead of traces are averaged.

[AVG ON/OFF]

Menu F3-1: Initiates or stops averaging on the entry channel. When averaging is off, it is the same as if averaging were active with an averaging value of 1. Each measured trace will be displayed. This feature is particularly useful when it is desired to adjust a device under test (DUT) while getting the fastest feedback possible, but an averaging factor has already been entered in the instrument to use for final test. In this case, it is not necessary to have to remember the averaging factor and change it back and forth from 1 to the final test value. Instead, the averaging capability can just be turned on and off.

[SMOOTHING]

Menu F3-1: Smoothing filters a channel trace by performing a moving average on the data over a specified percentage of the sweep span. The parameter that specifies the percentage of the channel trace to be averaged for each data point is called the Smoothing Aperture.

Smoothing reduces ripple in the trace. Smoothing is not the best choice for reducing noise. In the presence of noisy signals, averaging should be used. When both smoothing and averaging are used, the 8003 first averages consecutive unsmoothed traces then smooths each resulting averaged trace.

[SMOOTH APERT]

Menu F3-2: Selects the smoothing aperture parameter when in the smoothing mode.

The smoothing aperture is the percentage of the channel trace to be averaged for each data point. The smoothing aperture can be either selected with the spin knob or entered through the numeric keypad. Acceptable smoothing values are from 0.1% to 20%.

Smoothing aperture windows above about 5% will result in the display visibly shifting to the left by an amount depending on the aperture selected. This results from the smoothed data being plotted at the beginning of each smoothed segment. Fine tuning of devices such as filters can be executed with either technique.

[SMOOTH ON/OFF]

Menu F3-2: Toggles to start or stop smoothing on the entry channel.

8003 Precision Scalar Analyzer

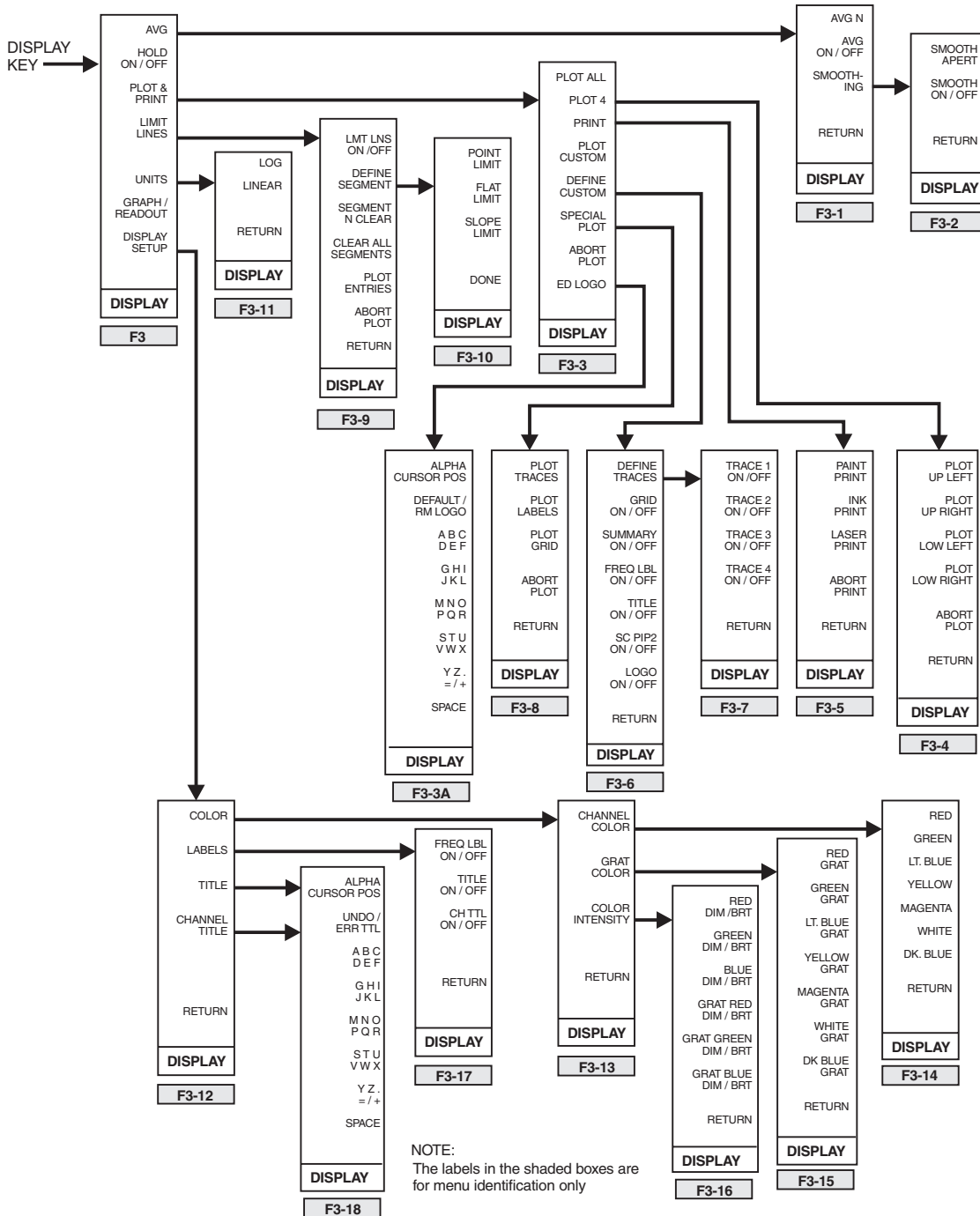

Figure 2-7: Function Menus Accessed w/ DISPLAY Key

[HOLD ON/OFF]

Menu F3: Stops the measuring of data and the update of the channel display to cause a hold or freeze of the display. The channel will remain frozen until the key is pressed again to toggle it back into the normal update mode.

When a channel is in the Hold mode, its status is indicated by the character **H** on the second line of its channel summary area on the display.

[PLOT & PRINT]

Menu F3: Accesses a series of sub-menus that offer you a variety of formats for the configuration of hardcopy printouts. This function is normally used when the system is operating in the Graph Display mode. If the instrument is in the CW mode, the function can address the [PRINT] softkey (see page 2-28) to allow the printing of a screen dump of the power meter readouts.

[PLOT ALL]

Menu F3-3: A standard plot is normally composed of a grid to define the scale, alphanumeric labels describing information pertaining to the trace data being presented, and the trace itself. The [PLOT ALL] softkey causes all of these elements to be printed on the hardcopy in a standard (8-1/2 x 11") format. If the 8003 has trace data available on all four channels, the data from each of channel can be printed in a different color on a 4 (or more) pen plotter. Figure 2-8 shows a typical PLOT ALL graph configuration.

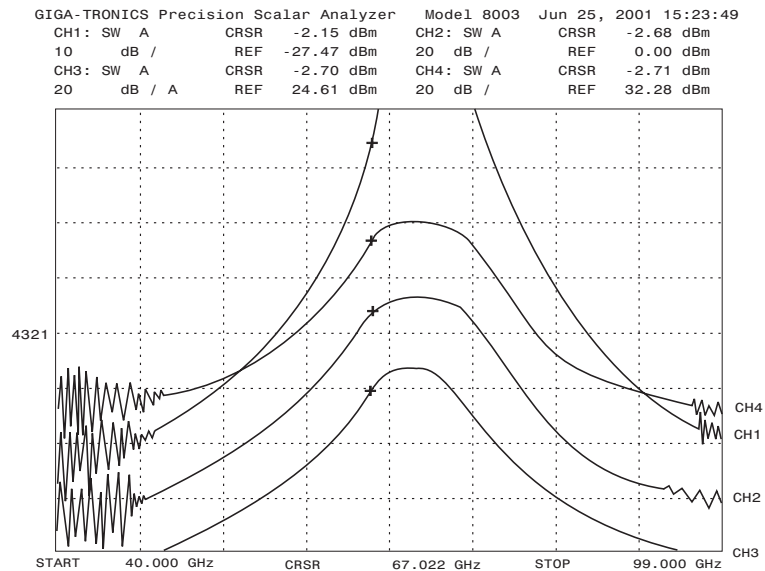

Figure 2-8: PLOT ALL Function Hardcopy Printout (Typical)

[PLOT 4]

Menu F3-3: Initiates the printing of separate plots for each of the four channels. Pressing [PLOT 4] brings up a sub-menu (F3-4) that allows you to select into which of the four quadrants of the hard copy each channel is to be positioned. The [PLOT UP LEFT], [PLOT UP RIGHT], [PLOT LOW LEFT], and [PLOT LOW RIGHT] softkey labels refer respectively to the Upper Left, Upper Right, Lower Left, and Lower Right quadrants of the printout. Pressing the desired location softkey allows you to define any of the four channels trace information to that quadrant. See Figure 2-9 below for an example of a PLOT 4 hardcopy printout.

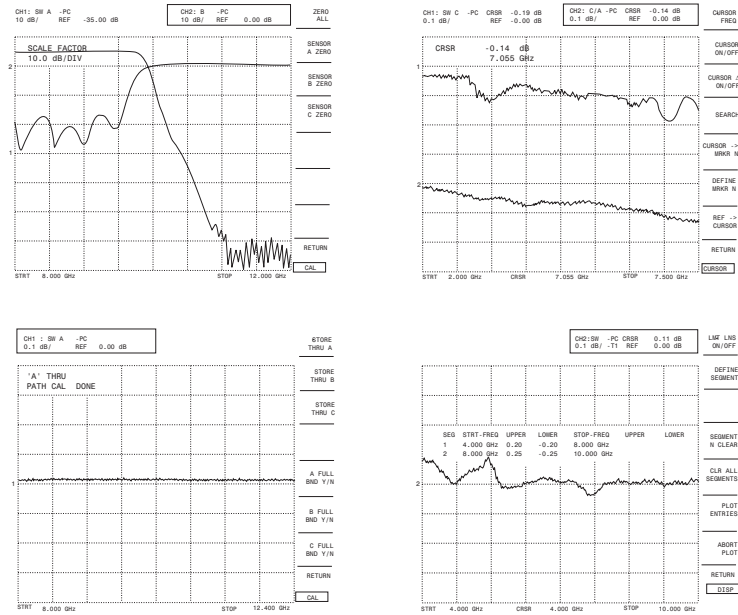

Figure 2-9: PLOT 4 Function Hardcopy Printout

[PRINT]

Menu F3-3: Accesses a sub-menu for selecting the type of printer for hardcopy output of data displayed on the CRT screen.

[PAINT PRINT]

Menu F3-5: Selects the output device that will generate the hardcopy to be an HP Paint Jet or equivalent.

[INK PRINT]

Menu F3-5: Selects the output device to be an HP Ink Jet or equivalent.

[LASER PRINT]

Menu F3-5: Selects the output device to be an HP Laser Jet or equivalent.

[ABORT PRINT]

Menu F3-5: Stops the printing process at any time.

[PLOT CUSTOM]

Menu F3-3: Activates a printout containing the plot parameters that were selected using the [DEFINE CUSTOM] softkey.

[DEFINE CUSTOM]

Menu F3-6: The Define Custom function allows you to select specific plot parameters to be shown on the hardcopy printout. [DEFINE CUSTOM] will bring up menu F3-6.

[DEFINE TRACE]

Menu F3-6: Displays menu F3-7 wherein any of the four channels can be defined to be ON or OFF (trace information printed or not printed on the hardcopy plot). Menu F3-6 also allows the selection of whether or not the background GRID, channel SUMMARY (alphanumeric information describing channel parameters), TITLE, and frequency labels (FRQ LBL) will be printed along with the plot of the channel trace configuration.

[SC P1P2]

Menu F3-6: Sets usage of the scaling parameters set up on the plotter itself for the hardcopy printout. Figure 2-10 is a similar function printout.

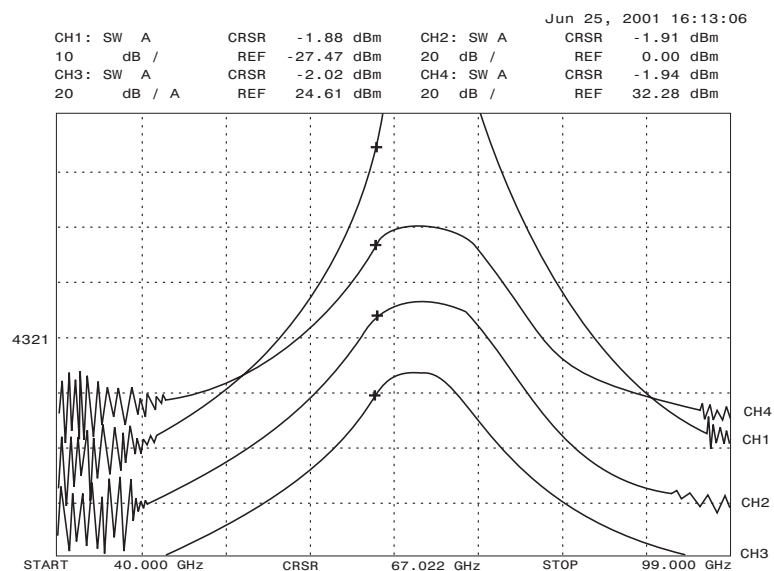

Figure 2-10: SC P1P2 Function Screen Hardcopy Printout

[SPECIAL PLOT]

Menu F3-3: Causes menu F3-8 to display. You can then define the channel TRACES, LABELS, or the background GRID to be printed with no other information appearing on the hardcopy.

[ABORT PLOT]

Menu F3-3: Aborts the plotting sequence at any time.

[ED LOGO]

Menu F3-3: Accesses Menu F3-3A where you can enter your company name or logo when desired. The logo will be stored in a non-volatile RAM so it will be retained during power down. Use of the [ALPHA/CURS POS] and alpha softkeys are similar to those of Menu F3-18 in Figure 2-7.

[LIMIT LINES]

Menu F3-9: Allows the limit lines for the entry channel to be edited or turned on and off. If the channel is within the limits that have been set for it, the channel number will be displayed with the word **PASS**. If the channel parameters are not within the set limits, the word **FAIL** will be displayed.

[LMT LNS ON/OFF]

Menu F3-9: Toggles the limit lines ON or OFF.

[DEFINE SEGMENT]

Menu F3-9: Generates a table on the screen for the entry of limit line parameters, and will also cause Menu F3-10 to be displayed. First, it is necessary to select the type of limit line from Menu F3-10. The choices are a POINT LIMIT, a FLAT LIMIT, and a SLOPE LIMIT.

When the softkey for the type of limit line is pressed, the 8003 will automatically assign a number between 1 and 12 to the segment to be defined and position a box to the START-FREQ column in the Limit Lines Table. The frequency is entered using the numeric keypad, and the digits will be shown in the data entry section of the display.

Appropriate values should also be entered for the remaining columns in the table depending on the type of Limit Lines selected.

When all of the values for a given segment have been entered, the ABORT choice on Menu F3-10 will change to DONE. Additional segments can be defined by assigning a new segment number and pressing the softkey for the type of Limit Line desired.

When [DONE] on Menu F3-10 is pressed, you will be returned to Menu F3-9 at which stage [LMT LNS ON/OFF] should be pressed to turn the Limit Lines ON. This will also activate the PASS/FAIL flag on the display.

[SEGMENT N CLEAR]

Menu F3-9: Clears all data for the segment selected. Clearing a segment does not change the value or position of any other data in the table.

[CLEAR ALL SEGMENTS]

Menu F3-9: Clears all of the segments for the active channel. It does not clear segments on non-active channels.

[PLOT ENTRIES]

Menu F3-9: Makes a hardcopy of the user-entered segment data that defined the limit lines.

[ABORT PLOT]

Menu F3-9: Stops the printing process at any time as desired.

8003 Precision Scalar Analyzer

[UNITS]

Menu F3: Selects the units (dB or W) in which the measurement on the entry channel will be displayed. The menu will change to Menu F3-11.

This key is active only in the CW mode. This is because swept mode data is always displayed in logarithmic (dB or dBm) units.

[LOG]

Menu F3-11: Changes the displayed measurements to dB or dBm as appropriate.

[LINEAR]

Menu F3-11: Changes the displayed measurements to units of mW or some other dimension of Watts.

[GRAPH/READOUT]

Menu F3: Toggles between displaying the results of a measurement in either graphic or alphanumeric readout format.

[DISPLAY SETUP]

Menu F3): Define the color of the various elements of the display, which labels should be displayed, and titles for the display and the entry channel (see Figure 2-7).

When the sub-menus associated with the COLOR and LABELS softkeys are accessed, the display will show the current state of the color or label of interest in light blue. The other color or label designations will be displayed in standard menu green.

When [DISPLAY SETUP] is pressed, the softkey menu will change to F3-12.

[COLOR]

Menu F3-12: Define the color of the entry channel trace with its summary information, the color of the graticule, and the intensity of the colors. When this softkey is pressed the softkey menu will change to F3-13.

[CHANNEL COLOR]

Menu F3-13: Choose the color of the entry channel trace and its summary information. When this softkey is pressed, the softkey menu will change to F3-14.

When one of the color softkeys shown in menu F3-14 is pressed, the color of the entry channel trace and its summary information will change to the color indicated by the softkey label.

[GRAT COLOR]

Menu F3-13: Choose the color of the display graticule. When this softkey is pressed, the softkey menu will change to F3-15.

When one of the graticule color softkeys shown in menu F3-15 is pressed, the color of the graticule will change to the color indicated by the softkey label.

This softkey choose the intensity of each basic color for both the channel data and the graticule.

When the [COLOR INTENST] softkey is pressed, the softkey menu will change to F3-16.

When either the RED DIM/BRT, GREEN DIM/BRT or BLUE DIM/BRT softkeys of menu F3-16 are pressed, the indicated color will dim or brighten everywhere except for the graticule.

When either the GRT RED DIM/BRT, GRT GRN DIM/BRT or GRT BLU DIM/BRT softkeys of menu F3-16 are pressed, the indicated color will dim or brighten for just the graticule.

[LABELS]

Menu F3-12: Specify which labels should be displayed. When this softkey is pressed, the softkey menu will change to F3-17.

[FREQ LBL ON/OFF]

Menu F3-17: Toggles the frequency labels to be displayed or removed from the graph display as indicated. The frequency labels include the start, stop, cursor and cursor Δ frequency labels which are shown at the bottom of the graphic display. This can be specified at any time. However, if the routine is in the data readout display mode, any changes will not be apparent until the graph display mode is entered.

[TITLE ON/OFF]

Menu F3-17: Toggles the main display title to be displayed or not displayed as indicated. See also the Title softkey description below regarding definition of the title.

[CH TTL ON/OFF]

Menu F3-17: Toggles the title of the entry channel to be displayed or not displayed as indicated.

[TITLE]

Menu F3-12: Edit the main display title. The [CHANNEL TITLE] softkey changes the entry channel title. When either softkey is pressed, the indicated title will be turned on if it is off and a cursor bar will flash immediately below the character space in the title to be filled when another character is chosen. The softkey menu will change to F3-18.

[ALPHA/CURS POS]

Menu F3-18: Selects whether to activate the alpha character softkey labels in order to create or modify a title, or to access control over the cursor positioning.

[UNDO/ERR TTL]

Menu F3-18: Erases a complete title or undo (restore) the title if erased by mistake. Note that it is only possible to undo the title if no new letters have been entered after selecting ERR TTL.

The alpha softkeys have labels of six characters each for selection of characters for the title being edited. A cursor in the form of a small square box will be over one of the characters in each alpha softkey label. The cursor will be in the same position in each of the alpha softkey labels. For example if the cursor is on A, it will also be on G, M, S and Y.

The cursor can be moved with the spin knob. Moving the wheel in a clockwise direction will cause the cursor to also move in a clockwise direction. For example, if the cursor is on the letter C and the spin knob is turned in a clockwise direction, the cursor will move to the letter F. Similarly, moving the spin knob in a counterclockwise direction will cause the cursor to also move in a counterclockwise direction. For example, if the cursor is on the letter A and the spin knob is turned in a counterclockwise direction, the cursor will move to the letter D.

If an alpha softkey is pressed, the associated character in the cursor box is inserted in the next character position in the title. Numbers can be inserted in the same way through the numeric keypad of the instrument. The point, hyphen, forward slash, and plus symbols can be inserted where required using the fifth alpha key, and a space can be placed at any point after the last character position using the bottom softkey of the menu. The Backspace (BK SP) key will also be active and, if pressed, will erase the last character defined in the title.

When the title is at its maximum length, the cursor will remain at the last character position and any new characters input will simply replace the last character in the string. When the title has been completed, the routine is returned to menu F3-12 by pressing the GHZ dB or ENT OFF function key to the right of the numeric keypad.

If any other key is pressed that forces the instrument to leave the editing of the title (such as a function key or a channel selection key), the title will be defined and stored as it is at the time the other key is pressed.

2.5.4 CAL Key

[CAL]

The FUNCTION [CAL] key is for path calibration, sensor calibration, and zeroing sensors and/or bridges. When [CAL] is pressed, the softkey menu will be as shown in F4 in Figure 2-11.

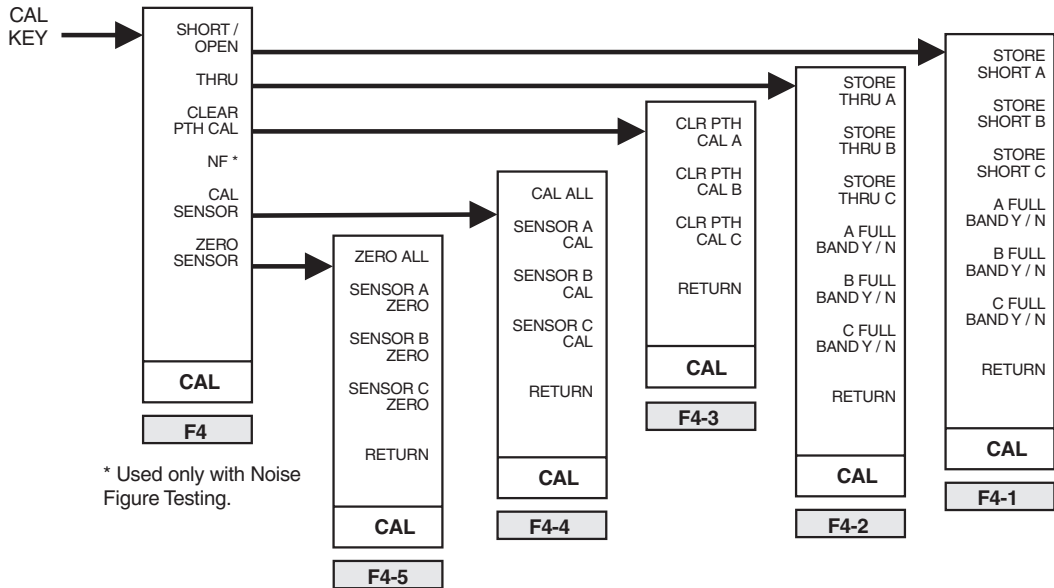

NOTE:
The labels in the shaded boxes are for menu identification only

Figure 2-11: Function Menus Accessed with the CAL Key

[SHORT/OPEN]

Menu F4: Allows you to perform a short/open path calibration on a bridge, or to update the bridge path calibration contained in memory.

When [SHORT/OPEN] is pressed, the softkey menu will change to allow the selection of input A, B, or C for the short/open calibration.

See [CLR PTH CAL] in the following descriptions regarding clearing path calibrations.

The softkey display will change to Menu F4-1 to present the option to either store the short data or return to Menu F4.

[STORE SHORT (A, B, or C)]

Menu F4-1: Initiates the collection of data which will be stored as the short path calibration data. When the key associated with the sensor of interest is pressed, the softkey menu will go blank. The active entry area of the display will contain the message, Storing Short. If the 8003 is controlling the source, it will temporarily select a source sweep time suitable for storing the large number of data points needed (up to 4096). The short data will be stored in memory as the short path calibration. Once this is done, the softkey menu will change to offer the option of either going through the same procedure for the open condition and storing the open data or returning to Menu F4.

[FULL BAND (A, B, or C) Y/M]

Menu F4-1: The 8003 uses adaptive normalization. That is, the start and stop frequencies can be changed within the frequency range for which the calibration was performed and the 8003 will automatically use the relevant calibration data.

Select **Y** to automatically set the start and stop frequencies to the full band of the sweeper during the calibration process. Then any subsequent start and stop frequencies will use path cal data.

Select **N** to store the path cal data for the user-selected frequency range only. In this case it would be necessary to repeat the path cal if it was required to make measurements outside of the original frequency range used for path cal.

[THRU]

Menu F4: Performs a sensor through-path calibration in case it has not already been done on a sensor currently being used, or in case it is desired to update the sensor path calibration data currently stored in memory. [THRU] brings up Menu F4-2 from where the sensor of interest can be selected. A through-path calibration is performed and is stored in the same manner as either the short or open path calibrations described previously.

[FULL BAND (A, B, or C) Y/M]

Menu F4-2: Function the same as those in Menu F4-1.

[CLR PTH CAL]

Menu F4: Accesses menu F4-3 wherein the desired sensor can be selected for the clearing of its path calibration. When the sensor softkey is pressed, the instrument will initialize the specified sensor's path calibration to a 0 dBm trace which would have no effect if ratio'ed with any measurement.

[CAL SENSOR]

Menu F4: Sensors and bridges must be calibrated before they can be used with the analyzer. The calibration linearizes the output voltage versus power input characteristics of the diode sensors. Once a sensor is calibrated, the analyzer will remember the calibration even when turned off as long as the sensor is used on the same channel on which it was calibrated.

Initiates the calibration of the 8003's sensors. When [CAL SENSOR] is pressed, the softkey menu will change to F4-4 for selection of either all sensors or the single sensor of interest.

Make sure that the sensor or bridge to be calibrated is attached to the calibrator output on the front panel of the 8003 before pressing any of the softkeys shown in menu F4-4.

[CAL ALL]

Menu F4-4: Initiates the routine to calibrate all of the 8003 sensors and bridges. The instrument will test its sensors to try and determine which one is currently connected to the calibrator, and then attempt to calibrate it. When it cannot calibrate a sensor, it will display a prompt to connect a sensor to the calibrator.

[SENSOR (A, B, or C) CAL]

Menu F4-4: Initiates the calibration of the corresponding sensor.

While the 8003 is calibrating a sensor, a special calibration display will be active (see Figure 2-21). This display shows the progress and success of the sensor calibration in progress.

If the instrument is unable to successfully complete the calibration (for example, the sensor/bridge might be damaged), the 8003 will exit the calibration routine and generate an audible warning signal.

During a sensor calibration, the softkey menu will offer the option to either Pause Cal or Abort Cal (as described below).

When the calibration completes, the 8003 will return to the Cal key menu (F4).

[PAUSE CAL] causes the 8003 to pause while performing its sensor calibration function. This can be done to allow an inspection of the calibration display. The first softkey menu prompt will then change from Pause Cal to Cont Cal.

[CONT CAL] commands the 8003 to continue with its calibration.

[ABORT CAL] causes the 8003 to stop any calibration procedure which is currently being performed, and return the routine to the Cal key menu (F4-1). Any previous calibration is retained and used. The new, partial calibration data is eliminated.

[ZERO SENSOR]

Menu F4: Initiates the zeroing of the sensors. When this softkey is pressed, the softkey menu will change to F4-5.

Zeroing eliminates any sensor drift. It is especially important for accurate low level measurements (40 dBm). At very low levels (60 dBm), zeroing should be done every few minutes.

[ZERO ALL] and [SENSOR (A, B, and C)]

Menu F4-5: Causes the 8003 to attempt to zero all of its calibrated sensors. Pressing SENSOR A, SENSOR B, or SENSOR C will zero one sensor at a time.

If a supported sweeper is connected to the analyzer, the analyzer will issue an RF-OFF command via the GPIB to turn the sweeper's RF OFF. If using non-supported sweepers (sweeper cannot be controlled over the Private Line GPIB), it is very important to make sure that the RF power is off to all of the sensors before pressing the ZERO ALL softkey.

2.5.5 CURSOR Key

[CURSOR]

The cursor can be thought of as a vertical line on the CRT display located at one frequency. As this implies, there is only one cursor frequency for all channels. This frequency is displayed at the bottom of the display screen on the frequency data line whenever the cursor has been turned on. Every channel intersects that cursor at a particular power level. The intersections between the cursor frequency and the signal trace of each channel is marked by a small cross (+). The power level of each channel at the cursor frequency is displayed in the channel summary information area of the screen.

Markers are an important feature of the 8003, and are intimately related to the cursor. The 8003 always knows the frequency of the signal through its control of the source and monitoring of the sweep ramp input. This allows the 8003 to place frequency markers on the signal trace without using any source marker capability. As a result, the 8003 cursor capability is only usable when the entry channel is in the swept mode. If the entry channel is in the CW mode when the **[CURSOR]** key is pressed, all of the softkey labels will be in dim, dark blue and pressing any of the softkeys will have no effect.

Markers are displayed on the 8003 as small circles on the traces at specific frequencies. Markers are channel independent like the cursor. When a marker is set at a particular frequency, the marker will be visible on all channel traces. The 10 markers available in the 8003 are set by moving the cursor to the desired frequency, and then by defining the marker to be at that frequency.

The FUNCTION **[CURSOR]** key provides access to the complete cursor and marker capability of the 8003. When the CURSOR key is pressed and the entry channel is in the swept mode, the cursor will be turned on and the entry area of the display will indicate the cursor frequency and power for the entry channel. You can move the cursor with either the spin knob or the keypad. The softkey menu will change to menu F5 as shown in Figure 2-12 on page 2-42.

[CURSOR FREQ]

Menu F5: Moves the cursor. Pressing this softkey causes the entry area of the display to indicate the cursor frequency and power for the active channel. The cursor can be moved by changing the frequency with either the spin knob or the enter keypad, as desired.

[CURSOR ON/OFF]

Menu F5: Toggles the cursor on and off (see the Cursor Δ Off next page). When the cursor is turned on or off, this function will occur for all the channels. When the cursor is turned off, the cursor Δ is also turned off. When the cursor is turned on it is assumed that it might be desired to change the cursor position. Therefore, the entry area of the display will show the cursor frequency and the power at the cursor for the entry channel. The cursor can be moved by using either the spin knob or the numeric entry keypad.

If the cursor is off and any entry made or action taken that requires a cursor, the cursor capability will automatically be turned on.

[CURSOR Δ ON/OFF]

Menu F5: Toggles the cursor Δ on or off. The state that the cursor Δ capability is currently in (On or Off) is displayed in light blue.

When the cursor Δ is turned on, the regular cursor capability of the instrument will also be turned on if it is off. The cursor Δ frequency is set to the frequency of the regular cursor, and a Δ symbol is placed at the cursor frequency on all channel traces. At that moment, the two cursor symbols will be superimposed upon each other. When the cursor Δ is on, the cursor Δ frequency is displayed at the bottom of the display on the frequency label line.

While the cursor Δ is on, all regular cursor power measurements are made relative to the power level at the cursor Δ . When the cursor Δ is turned on, it is then possible to move the regular cursor. The entry area of the display will indicate both the cursor frequency and the power at the cursor frequency relative to the power at the cursor Δ frequency for the entry channel. The regular cursor frequency can then be changed by using either the spin knob or the numeric entry keypad.

When the cursor Δ is turned off, the displayed cursor power reverts to the power level of the measurement being taken at the cursor frequency.



NOTE: When the regular cursor capability is turned off, the cursor Δ is automatically turned off. If the regular cursor capability is then turned back on, this will not reactivate the cursor Δ capability which must be separately turned on again.

8003 Precision Scalar Analyzer

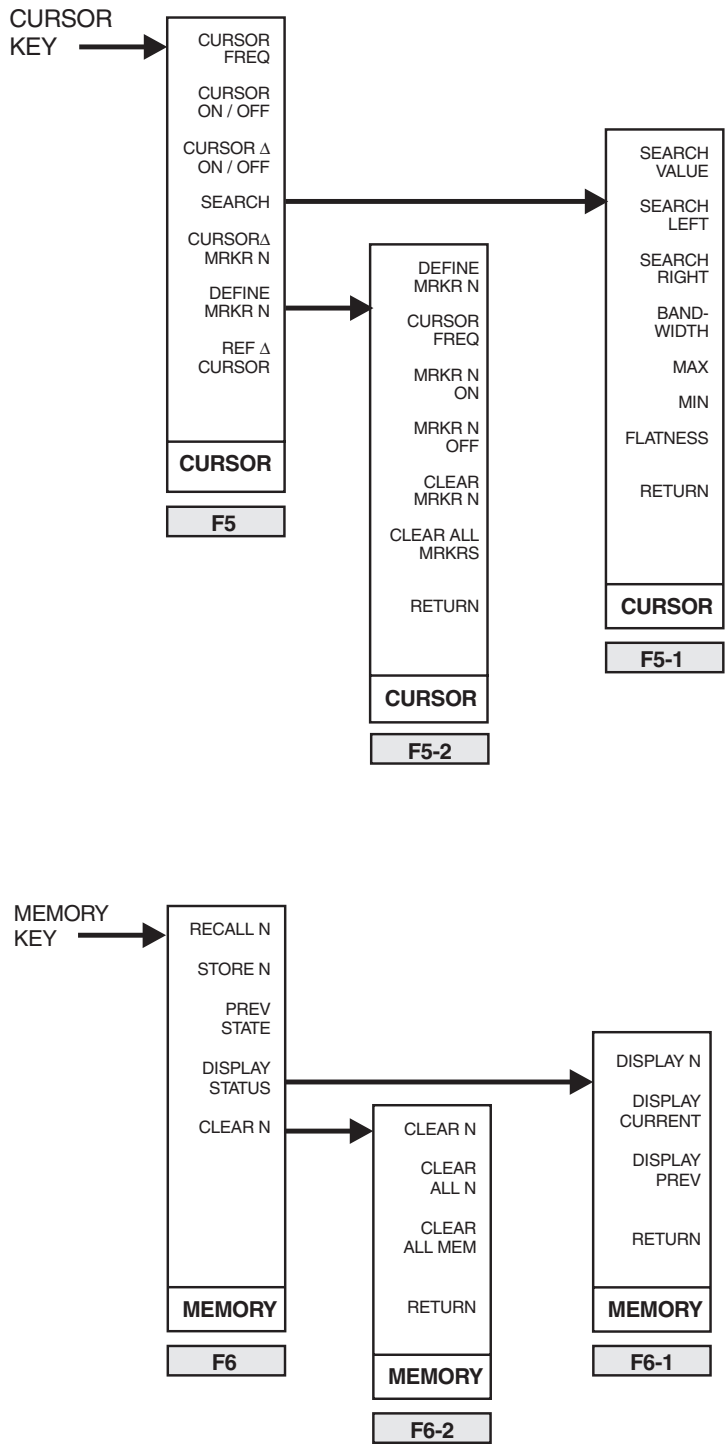

NOTE:

The labels in the shaded boxes are for menu identification only.

Figure 2-12: Function Menus Accessed with the CURSOR & MEMORY Keys

[SEARCH]

Menu F5: Searches for and places a cursor at a user-defined level on the entry channel. When cursor Δ is active, SEARCH will look for and place a cursor at the user-defined level relative to the reference cursor.

When this softkey is pressed, the cursor capability will be turned on if it is off. The entry area of the display will show the current search value for the entry channel and allow it to be changed.

The softkey menu will change to F5-1 as shown in Figure 2-12.

[SEARCH VALUE]

Menu F5-1: The Search Value is the value for the entry channel that the search function will look for when a search is requested. If a cursor Δ is active, the search will be for the level relative to the cursor. If the cursor Δ is not active, the search will be for the level that is equal to the search value.

When [SEARCH VALU] is pressed, the entry area of the display will indicate the current search value for the entry channel and present a prompt to enter a new search value as desired.

[SEARCH LEFT] and [SEARCH RIGHT]

Menu F5-1: Initiates the search function. If the cursor Δ is active, the 8003 will search in the indicated direction (left or right) from the current position of the cursor. It will look for the level that is equal to the search value in relation to the level at the cursor Δ . If the cursor Δ is not active, the 8003 searches in the appropriate direction from the current position of the cursor to look for the level that is equal to the selected search value.

When the search has completed, the trace will be put on hold. The hold can be turned off by pressing any front panel key. This hold is provided to allow the trace to be examined in the same state as it was when the search was conducted. While in the hold state, the entry area of the search was conducted. While in the hold state, the entry area of the display will show the power level and a message indicating whether the search was successful, the message will be Value Found: Trace HOLD. If the search was unsuccessful, the message will be "Error: Cursor Value not Found" and the cursor will not have moved.

Once a search has been completed, the search value can be changed and the same search (left or right) conducted by entering a new search value. If it is desired to exit the trace HOLD state that follows a search, this can be done by pressing a number key. The entry area of the display will show the number being entered. A search value can then be entered in a similar manner as pressing the search value softkey. The significant difference is that once the number entry is completed, the search value is changed and a new search is initiated.

To enter a new search value, but not initiate the same type of search again, the [SEARCH VALUE] softkey should be pressed.

[BANDWIDTH (BW)]

Menu F5-1: If the BW search value is a negative dB value, pressing [BANDWIDTH] initiates both a right and a left search simultaneously, starting from the maximum power level of the entry channel trace. If the BW search value is a positive dB value the searches are performed similarly, only starting from the minimum power level of the entry channel trace.

As the preceding description implies, this function requires two markers. Therefore, if the bandwidth function is successful, the cursor Δ capability of the instrument will be turned on if it was off. When this function is used, the cursor Δ will always be positioned to mark the left bandwidth marker on the display. Once the cursor capability has been turned on in this way, it can only be turned off by returning to the cursor menu and using the [CURSOR ON/OFF] soft-key (as previously described).

Other than the use of the cursor, the use of the bandwidth capability is very similar to the Search Left and Search Right functions. The trace is put on hold after the search, and the display of success or failure messages will be the same. At this point, a new bandwidth search value can be entered and another bandwidth search initiated by entering a new search value as previously described for the Search Left and Search Right functions.

[MAX] and [MIN]

Menu F5-1: Positions the cursor at the frequency corresponding to the maximum or minimum level of the entry channel trace. When either key is pressed, the cursor capability of the instrument will be turned on if it is off. The regular cursor will be positioned at the requested level. MAX and MIN can be done with respect to the regular cursor when the cursor Δ is active.

[FLATNESS]

Menu F5-1: Automatically displays (in dBm) the total deviation (flatness) between the MAX and MIN values of the displayed signal trace. This eliminates the necessity of having to read the MAX value, then the MIN value, and then having to subtract to determine the flatness figure.

[CURSR \rightarrow MRKR N]

Menu 5-1: Moves the cursor to a defined marker position. An undefined marker is a marker that has not been assigned to a frequency since a preset was performed, or since the marker was cleared. When this softkey is pressed, the cursor capability will be turned on if it is off. The entry area of the display will present a prompt to enter the number of the marker (0 through 9) to which it is desired to move the cursor. The spin knob can move the cursor to the next marker in the indicated direction. Continuing to spin the wheel will cause the routine to jump from marker to marker until the desired frequency is reached.



NOTE: *Markers need to be turned ON prior to this function.*

[DEFINE MRKR N]

First Level Menu F5: Defines a marker at the cursor frequency. This softkey is also used to turn markers on and off and to clear markers. When this softkey is pressed, the cursor capability will be turned on if it is off. The entry area of the display will present a prompt to enter the number (0 through 9) of the marker that it is desired to define at the cursor frequency. The default number will be the lowest marker number which has not already been defined. If all markers are currently defined, then there will be no default number. The softkey menu will change to menu F5-2.

When a number is entered, a marker small circle will be superimposed on the cursor on each trace and will remain at that frequency when the cursor is moved. If the number of a marker that is already defined is entered, then the previous frequency definition will be lost and the marker will automatically be turned on if it was off.

[DEFINE MRKR N]

Second Level Menu F5-2: If the DEFINE MRKR N softkey is pressed again, the entry area of the display will present a prompt to enter the number (0 through 9) of the marker it is desired to define at the cursor frequency. This softkey will work identically to the DEFINE MRKR N softkey that led to this sub-menu except that this softkey will not change the softkey menu. This softkey option is provided in this menu so that one of the other softkeys in the menu (such as changing the cursor frequency) can be used while still retaining the ability to define a marker.

[CURSOR FREQ]

Menu F5-2: Moves the cursor. Pressing this softkey causes the entry area of the display to indicate both the cursor frequency and the level at the cursor for the entry channel. A prompt will be presented to move the cursor by changing the frequency with either the spin knob or the enter keypad, as desired.

This is the same type of data entry that is allowed when the Cursor key is pressed as well as when the CURSOR FREQ softkey is pressed in the prior menu. It is provided here to allow both the changing of the cursor and the defining of markers from one softkey menu.

[MRKR N ON] and [MRKR N OFF]

Menu F5-2: Turns any defined markers off and on without having to redefine their frequencies. When a marker is turned off, its tic mark is no longer displayed on the measurement traces and the cursor can no longer be assigned to the marker. This allows markers to be set up for different tests while only displaying the relevant markers for each particular test, as desired.

When one of these softkeys is pressed, the entry area of the display will present a prompt to enter the number of the marker that it is desired to turn on or off. The default will be to turn all defined markers on or off. This would occur if the enter key were pressed without entering a number. Note that only defined markers can be turned off or on. An error message will be generated if the number of an undefined marker is entered.

If the sweep frequencies were changed so that the frequency of a defined marker is outside the limits of the frequency range currently being swept, then the marker would automatically be turned off. Such a marker cannot be turned back on again until the sweep frequencies are changed to allow the marker to be displayed.

[CLEAR MRKR N]

Menu F5-2: Clears a defined marker. When a marker is cleared it is turned off, its defined frequency is erased, and it becomes an undefined marker. When this softkey is pressed, the entry area of the display will present a prompt to enter the number of the marker that it is desired to clear. The frequency of a cleared marker can not be recalled.

[CLEAR ALL MRKRS]

Menu F5-2: Clears all the markers. When the markers are cleared they are turned off, the frequencies that were defined for them are erased, and they become undefined markers.



NOTE: *The frequency of a cleared marker can not be recalled.*

Another softkey menu will be presented giving you the choice to either clear all markers or to abort. When the CLR ALL MRKRS softkey is pressed again, all markers will be cleared. The entry area of the display will indicate that the markers have been cleared, and the routine will return to the DEFINE MRKR N menu (F5).

If the [ABORT CLEAR] softkey were pressed, the routine would return directly to the DEFINE MRKR N softkey menu (F5). No Markers would be affected by this action.

[REF → CURSOR]

Menu F5: Changes the main trace reference power level to equal the power level at the cursor on the entry channel. If the cursor is inactive pressing this softkey will activate the cursor, place it at its last frequency position, and then change the reference level.

2.5.6 MEMORY Key

[MEMORY]

The FUNCTION **[MEMORY]** key accesses the Store and Recall of instrument setups. These setups are stored in non-volatile memory and will not be disturbed upon power down. When the MEMORY key is pressed, the entry area of the display will present a prompt to enter the number of the stored setup to be recalled. The softkey menu will change to menu F6 shown in Figure 2-12.

The stored setup recall will occur as soon as the setup number is entered. Then the entry area will indicate the recall is complete, and allow the entry of another setup number to recall if so desired.

[RECALL N]

Menu F6: Recalls an instrument setup that was stored using the STORE N softkey. When this softkey is pressed, the entry area of the display will present a prompt to enter the number of the setup to be recalled. When the setup number is entered, the stored instrument setup is recalled. The entry area will then indicate that the recall is complete, and allow the entry of another setup number to recall if so desired.

This is the same action that takes place when the MEMORY key is pressed. It is provided here in case another of the softkeys in the memory menu (such as STORE N to store the current setup) has been used, and it is then desired to recall a setup.

[STORE N]

Menu F6: Stores the current instrument setup as a numbered setup in non-volatile memory. When this softkey is pressed, the entry area of the display will present a prompt to enter the number under which the current setup will be stored. When the setup number has been entered, the current setup will be stored. The entry area of the display will indicate that the storing is complete, and allow the entry of another number under which to store the current setup if so desired.

[PREV STATE]

Menu F6: Undo any Preset conditions and Recall information.

[DISPLAY STATUS]

Menu F6: Examine the settings of stored setups without having to recall the setups. It can also be used to examine the settings of the current setup of the instrument. When this softkey is pressed, the entry area of the display will present a prompt to enter the number of the setup to be displayed.

The softkey menu will change to sub-menu F6-1.

[DISPLAY N]

Menu F6-1: Displays an instrument setup that was stored using the STORE N softkey. When the DISPLAY N softkey is pressed, the entry area of the display will present a prompt to enter the number of the setup to be displayed.

This is the same action that takes place when the DISPLAY STATUS softkey is pressed. It is provided here in case another of the softkeys in the Display menu is used, and it is then desired to display a numbered setup.

When the number of the setup to be displayed is entered, the 8003 will stop taking and displaying measurements. The measurement area of the display will instead show all of the requested setup's parameters.

The softkey area will change to offer the option to either continue or abort the routine.

The setups of the 8003 are displayed on a set screens. The [CONT] softkey indicates to the 8003 when it should replace the current display screen with the next display screen. When the last screen defining a setup has been displayed, press [CONT] to wrap the routine around and again display first screen.

Press [ABORT] to stop the routine and return to the Display Status menu (F6).

[DISPLAY CURRENT] and [DISPLAY PREV]

Menu F6-1: When either of these softkeys are pressed, the respective setups are displayed in the same way stored setups described above. As the softkey label indicates, [DISPLAY CURRENT] displays the current setup. [DISPLAY PREV] shows the setup that existed just before a setup parameter was last changed. This is also the setup that would be restored if [PREV STATE] is pressed in the Memory menu (F6).

[CLEAR N]

First Level Menu F6: Clears both stored setups and all of non-volatile memory. When a setup is cleared, it is initialized in the same manner that the current setup when [PRESET] is pressed. When [CLEAR N] softkey is pressed, the entry area of the display will present a prompt to enter the number of the setup to be cleared.

The softkey menu will change to sub-menu F6-2.

[CLEAR N]

Second Level Menu F6-2: Clears an instrument setup that was stored using the [STORE N] softkey. When [CLEAR N] is pressed, the entry area of the display will present a prompt to enter the number of the setup to be cleared.

This is the same action that takes place when [CLEAR] is pressed. It is provided here in case another of the softkeys in the Clear menu has been used, and it is then desired to clear a numbered setup.

When the number of the setup to be cleared is entered, the 8003 will clear the stored setup and indicate in the entry area of the display that it has completed this task. The number of another stored setup to be cleared can then be entered.

[CLEAR ALL N]

Menu F6-2: Clears all stored setups. This does not provide access to clear the current setup or previous state setup. Press [PRESET] to clear the current setup; press [PRESET] twice to clear both the current and the previous setups.

The softkey menu will change to offer the option of either Clearing All or aborting the routine.

When the [CLEAR ALL N] softkey is pressed, all of the stored setups are cleared. The entry area of the display will indicate that the setups have been cleared, and the instrument will return to the Memory key primary menu (F6).



NOTE: *This action cannot be reversed once accomplished.*

If the [ABORT CLEAR] softkey were pressed, the routine would return directly to the Memory key primary menu (F6). The stored setups will not be affected.

[CLEAR ALL MEM]

Menu F6-2: Clears all information contained in the non-volatile memory. This includes the current setup, the previous state setup, all stored setups, all stored traces, and all defined user tests.

The softkey menu will change to offer the option to either clear all of the non-volatile memory or to abort the routine.

8003 Precision Scalar Analyzer

When the [CLEAR ALL MEM] softkey is pressed, all of the non-volatile memory will be cleared and the instrument will be Preset.



NOTE: *This action cannot be reversed once accomplished.*

If the [ABORT CLEAR] softkey were pressed, the routine would return to the CLEAR N softkey menu (F6-2). Non-volatile memory will not be affected.

2.6 SOURCE Controls

2.6.1 General Description

The 8003 is programmed to automatically control compatible signal sources through its private GPIB bus (see Section 2.6.3). Commands are generated by using the four Source keys located on the front panel of the 8003. Manual control of the source by the user is not required in this mode. The instrument also has a local mode in which it does not control the source, but some features are not available in this mode.

2.6.2 ATE Operation

When the 8003 is in an ATE environment and under GPIB control, the source might still be on the 8003 private line interface. When the source is on the 8003's private line interface in an ATE system, the 8003 will still control the source as it does under front panel operation. It is only necessary to send commands to the 8003 to cause it to set up both itself and the source for standard scalar measurements. If it is desired to control the source from a controller other than the 8003, the 8003 can be set to turn its private bus off (see Menu SY1-10 in Figure 2-16). This will put the source into the local mode of operation.

When the source is in the local mode of operation, the source controls on can be used for specifying the start and stop frequencies to be indicated on the scalar display and for power measurement correction with frequency. In this mode, the start and stop frequencies defined on the 8003 will not affect the source settings.

2.6.3 8003 Source Compatibility

The 8003 is compatible with a range of sweepers that have an output identify command. The analyzer tries to identify the source by sending the output identify commands of all the sweepers with which it is compatible until it gets a response that it recognizes. If it gets a response that it recognizes, the 8003 will then interrogate the known source to find out its parameter limits (frequencies, power level, etc.). With this scheme the analyzer can, of course, only be compatible with sweepers that will identify themselves and output their operating parameters. A source such as the HP8350A has no output capability, therefore a new scheme has been devised to allow the 8003 to control this instrument.

Through a menu entry the 8003 can be set up to operate in the usual Auto Select Mode where it tries to interrogate the source it detects on the private bus as described above. Another mode is available in which the operator can tell the 8003 specifically which sweeper is connected to its private bus. In this way the 8003 outputs the control commands of the user selected sweeper and, if that sweeper is in fact connected, then the interface will work normally. The 8003, however, will have no knowledge of the sweepers maximum and minimum parameter values. This will permit the user to possibly enter values of frequency and power that are outside the sweeper's valid ranges for these parameters. In the case of the 8350A, it will set these values to their maximum or minimum. The fact that the 8003 does not know the sweeper's max or min frequency levels means wide band path calibrations are not valid. The menu entry will be dim, dark blue in this case.

2.6.4 Key Operation

2.6.4.1 UPDATE SWEEPER ON/OFF Key

[UPD SWP ON/OFF]

The UPD SWP ON/OFF (Update Sweeper On/Off) softkey function appears in all of the Source Control menus. Its purpose is to enable or disable the source sweeper configuration update. The default is ON (enable). For example: If it were desired to display a range of 1 to 10 GHz on the 8003 but the sweeper output is from 2 to 5 GHz, the following procedure would be accomplished:

- Set 2 to 5 GHz using the source Start and Stop functions
- Turn OFF the UPD SWP function
- Set the 8003 frequency for a range of 1 to 10 GHz

 **NOTE:** A potential problem may occur when the 8003 and sweeper have different configurations after the above is performed. Be sure to preset the instrument for consistent operation.

2.6.4.2 START Key

[START]

The SOURCE [START] key initiates source frequency changes by specifying the desired start, center, or CW frequencies depending upon the mode of operation.

When [START] is pressed, the entry area of the display will show the current start, center, or CW frequency depending upon whether the source is in the start/stop, center/ ΔF , or CW mode, respectively. A prompt will be displayed to change the frequency if desired, and the softkey menu will change to the one illustrated in Figure 2-13.

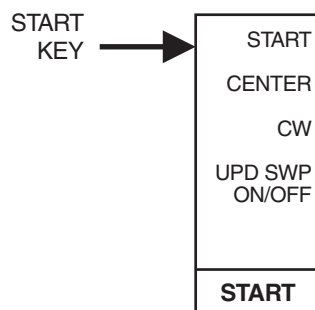

Figure 2-13: Softkey Menu Change from Frequency Change Prompt

[START], [CENTER], and [CW]

These softkeys change the mode and frequency of the source. The softkey label that corresponds to the mode currently in use (START for Start/Stop, CENTER for Center/ ΔF and CW) will be in light blue. The other two options will be shown in standard menu green.

Pressing a softkey with a standard menu green label will cause the source to immediately switch to measuring in the mode indicated by the softkey. The current value for the frequency associated with

the softkey (START, CENTER or CW) will be displayed in the entry area of the display. For example, if the source were in the Start/Stop mode, the START label would be in light blue. If the [CENTER] softkey were pressed, then the CENTER label would change to light blue, the START label would change to standard menu green, and the source would begin measuring in the Center/ ΔF mode using the frequencies that were last entered for the Center and ΔF frequencies.

The frequency ranges that have been defined for the start/stop frequencies and the center/ ΔF frequencies are completely independent. Whenever a change is made from one frequency mode (start/stop, or center/ ΔF) to the other, the instrument will always revert to the frequency range that was last defined for the mode to which the instrument is switched. Similarly the frequency of the source CW output is also independent of the start, stop, center, and ΔF frequencies. New frequencies are entered using the numeric keypad and the appropriate terminator key.

2.6.4.3 STOP Key

[STOP]

The SOURCE [STOP] key initiates the source frequency changes. It allows the stop, ΔF , or CW frequencies to be specified depending upon the mode of operation. See the description of the UPD SWP ON/OFF softkey section .

When [STOP] is pressed, the entry area of the display will show the current stop, ΔF , or CW frequency, depending upon whether the source is in the start/stop, center/ ΔF , or CW mode, respectively. A prompt will be presented to change the frequency if desired, and the softkey menu will change to the menu in Figure 2-14.

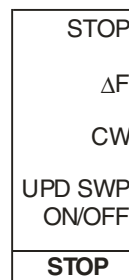

Figure 2-14: Stop Key Softkey Menu Prompt

[STOP], [ΔF] and [CW]

These softkeys change the mode and frequency of the source. The softkey label that corresponds to the mode currently being used (STOP for Start/Stop, ΔF for Center/ ΔF , and CW) will be in light blue. The other two options will be in standard menu green.

Pressing one of the softkeys with a standard menu green label will cause the source to immediately switch to measuring in the mode indicated by the softkey pressed. The current value for the frequency associated with the softkey pressed (STOP, ΔF , or CW) will be displayed in the entry area of the display. For example, if the source were in the Start/Stop mode, then the Stop label would be in light blue. If the ΔF softkey were pressed, then the ΔF label would change to light blue, the Stop label would change to standard menu green, and the source would begin measuring in the Center/ ΔF mode using the frequencies last entered for the Center and ΔF frequencies.

2.6.5 POWER Key

[POWER]

See the description of the UPD SWP ON/OFF softkey in section 2.6.4.1.

The frequency ranges of the sweeps defined by the start/stop frequencies and the center/ ΔF frequencies are completely independent. Whenever one frequency mode (start/stop or center/ ΔF) is changed to the other, the instrument will always revert to the frequency range last defined for the mode to which the instrument was switched. Similarly the frequency of the source CW output is also independent of the start, stop, center, and ΔF frequencies.

The SOURCE [POWER] key initiates source power level changes. When pressed, the entry area of the display will show the power level the source is set to output and present a prompt to change the level as desired. The softkey menu will change to the menu on the left in Figure 2-15.

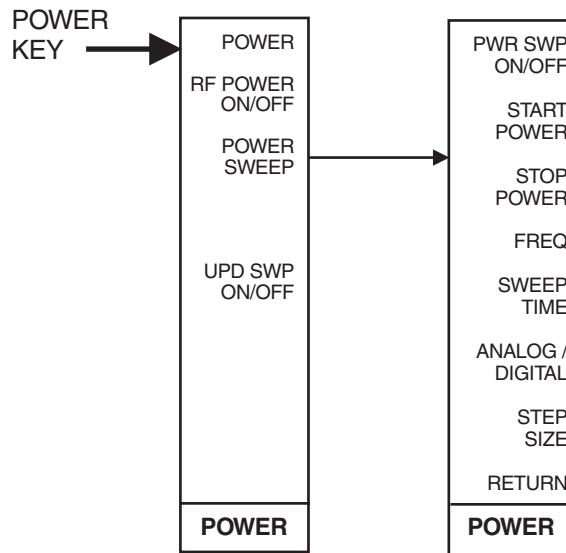

Figure 2-15: Power Softkey Menu Prompt

[POWER]

The entry area of the display will show the currently defined output power for the source and present a prompt to change the power as desired.

This is the same type of data entry that is used when the POWER function key is pressed. It is provided here in case another parameter in the Power key menu is changed, and it is then desired to change the power level. Changing the power level can be selected here as another option in the softkey menu without the necessity of going from the softkey menu to the Source Control keys.

[RF POWER ON/OFF]

Turns the RF power output of the source on or off. The state that the source output power is currently in (On or Off) will be displayed in light blue. The other state that the source would enter if the softkey were pressed will be displayed in standard menu green.

[POWER SWEEP]

Turns on the Power Sweep function as described in Section 2.14. The following sub-menu softkey selections will be available (as shown in Figure 2-15):

[PWR SWP ON/OFF]

Controls the enabling or disabling (toggle) of the power sweep measurement mode.

[START POWER]

Allows the entry of the desired power sweep starting power level (in dBm).

[STOP POWER]

Allows the entry of the desired power sweep stopping power level (in dBm).

[FREQ]

Allows setup of the desired power sweep operating frequency range.

[SWEEP TIME]

Allows setup of the desired analog sweep time.

[ANALOG/DIGITAL]

Selects either the analog or digital power sweep mode, as desired.

[STEP SIZE]

Allows setup of the digital power sweep step size.

[Sweep Time]

See the description of the UPD SWP ON/OFF softkey section 2.6.4.1.

The SOURCE **[SWEEP TIME]** function key initiates changing of the sweep time. When the key is pressed, the entry area of the display will show the currently defined sweep time and a menu similar to that shown below will be displayed.

2.6.6 SWEEP TIME Key

[SWEEP TIME]

When the SWEEP TIME softkey is pressed, the entry area of the display will again show the currently defined sweep time. Note that this is the same type of data entry that is allowed when the SWEEP TIME function key is pressed. The reason for the redundancy is so that it will not be necessary to leave the softkey menu and go to the Source Control function keys to change the sweep time.

[INT SWP TRIGGER]

This function is not currently implemented.

2.7 SYSTEM Controls

The system controls are keys that affect the instrument as a whole. This includes the keys used to configure the instrument and to preset the instrument. The SYSTEM section of the 8003 consists of the **[CONFIG]** and the **[PRESET]** keys.

2.7.1 PRESET Key

[PRESET]

The PRESET function key changes parameters that have been set for currently displayed back to the factory-set defaults. See Appendix B for a listing of the 8003 factory-set default values.

2.7.2 CONFIG Key

[CONFIG]

The sub-menus accessed through the **[CONFIG]** key contain a softkey label called either **[RETURN]** or **[DONE]** located at the bottom of the menus. Pressing this softkey will always return the routine to the menu immediately preceding the menu currently being displayed. Pressing the softkey more than once allows you to step backward through the menu structure to a preceding menu.

The CONFIG function key configures the scalar analyzer and any other devices that might be on its private GPIB bus. When **[CONFIG]** is pressed, menu SY1 shown in Figures 2-16 and 2-17 (pages 2-58 and 2-59) will appear.

[SENSORS AC/DC]

Menu SY1: Changes the detection mode of the sensors. Pressing this softkey will bring up menu SY1-1 to select either all or individual sensors as AC or DC. The state (AC or DC) that the setup sensor is currently in will be displayed in light blue. The other state that the sensor would enter if the softkey were pressed is displayed in standard menu green.

[SENSORS CW FREQ]

Menu SY1: Provides access to a series of sub-menus that allow you to specify which sensors will take measurements in the CW mode, and what frequency correction factors will be used with the sensors.

Whenever a channel is taking measurements in the swept mode, the 8003 determines the frequency of the signal from the sweep input. The instrument will expect the sweep input to be sweeping from 0 V to 10 V, with 0 V representing the start frequency and 10 V representing the stop frequency. The start and stop frequencies are assumed to be those that were specified by the use of the source control keys. The 8003 will automatically determine the frequency of the signal from the sweep input and correct the power readings of the sensor according to the frequency correction table stored in the sensor's PROM. See also the START key on page 2-52 and the STOP key on page 2-53 for the setting of the start and stop frequencies.

When a sensor is measuring in the CW mode it is possible to identify the frequency directly, specify a cal factor, or command the 8003 to automatically determine the frequency of the signal from its control of the source. If the 8003 is commanded to automatically determine the frequency of the signal, it will use the source's CW output frequency that was set by the 8003. If the 8003 is not controlling the source, the 8003 will still use the frequency set in the source control section. The specification of the CW mode of frequency correction is accessed through the **[SENSOR CW FREQ]** softkey.

The softkey label that represents the currently defined mode of CW frequency correction for the setup sensor will be light blue. All other softkey labels will be in standard menu green.

8003 Precision Scalar Analyzer

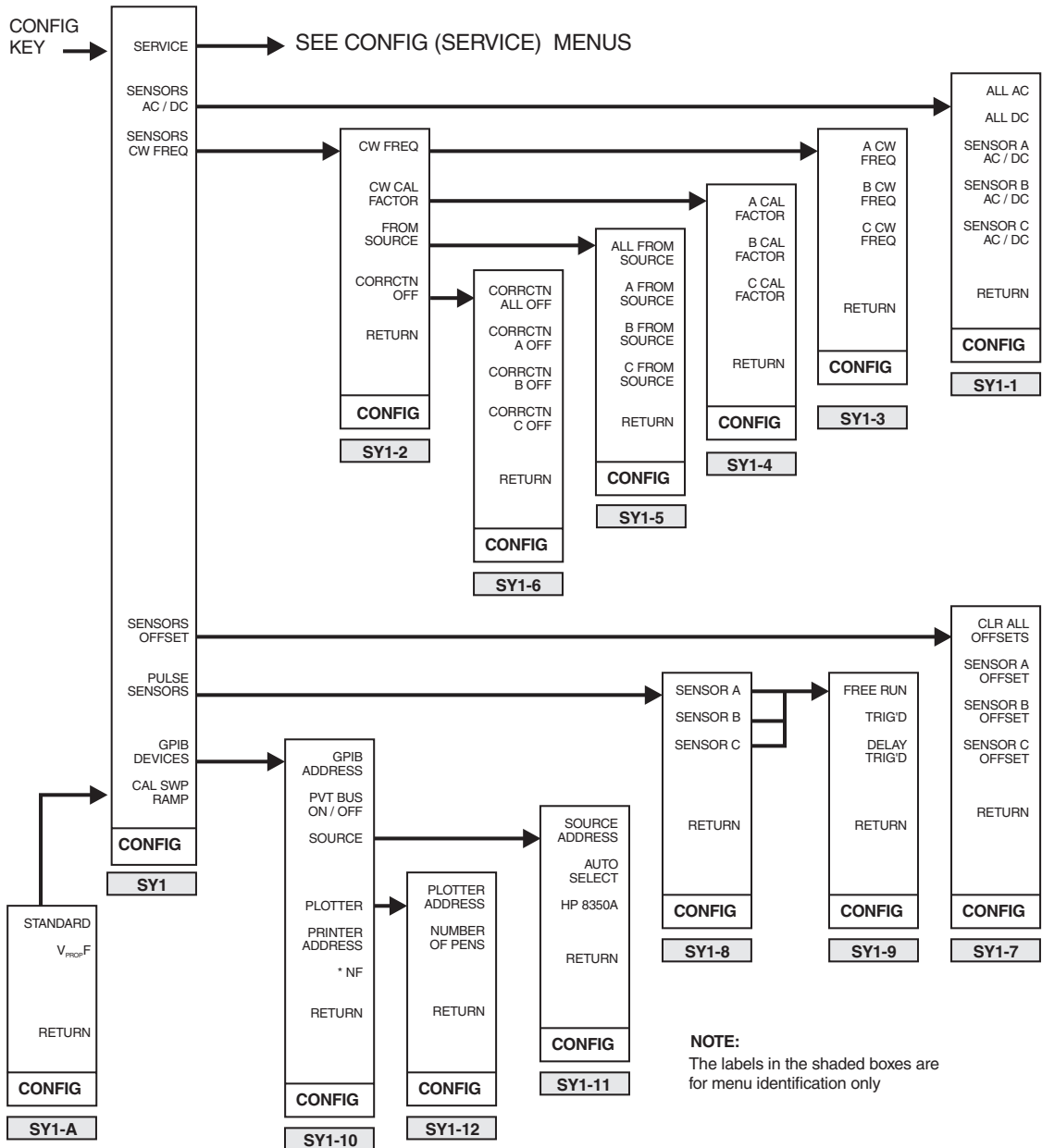

Figure 2-16: System Control Menus Accessed with CONFIG Key (Part 1)

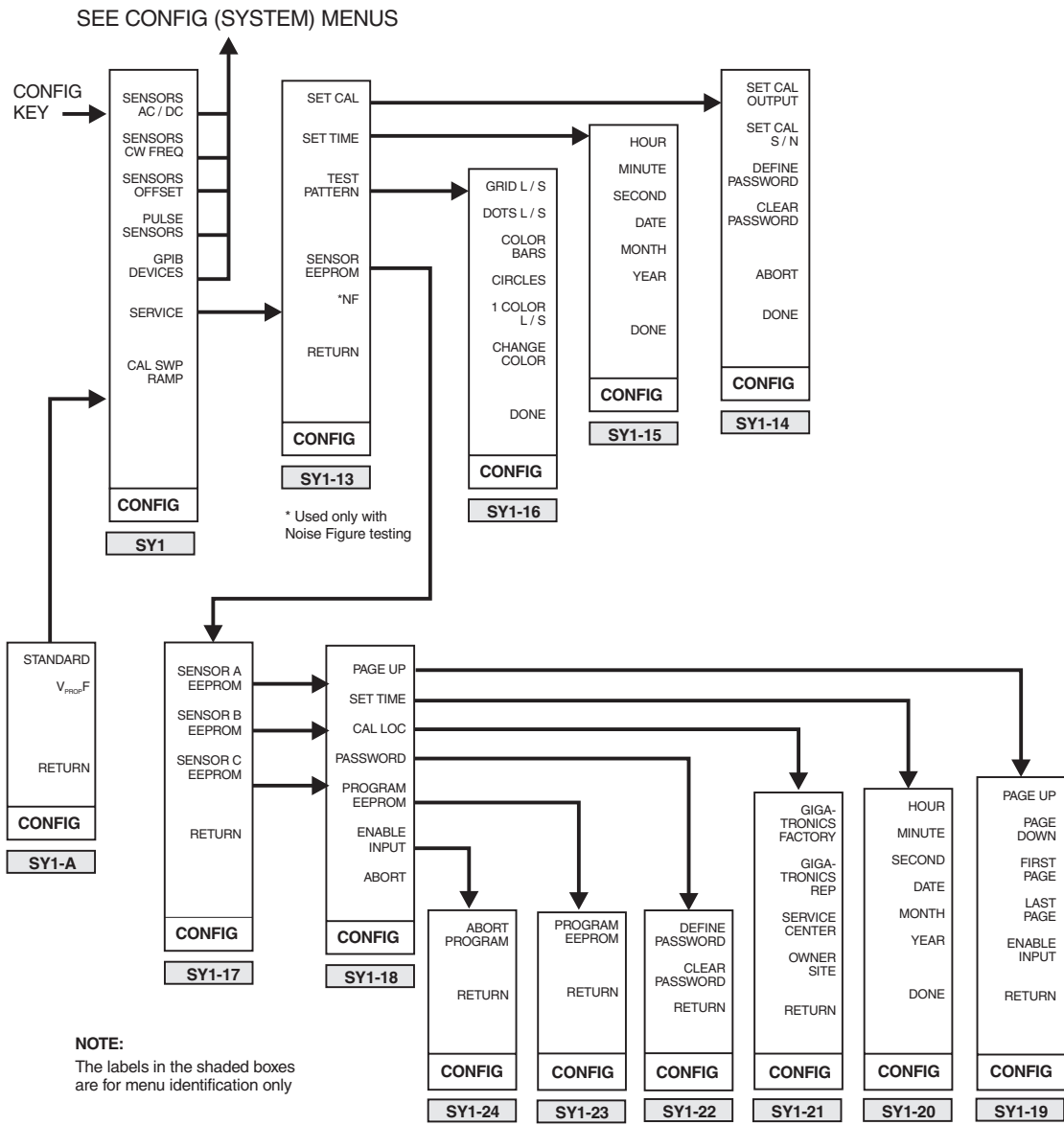

Figure 2-17: System Control Menus Accessed with the CONFIG Key (Part 2)

[CW FREQ]

Menu SY1-2: Directly specifies the frequency of the signal to the sensor. When this softkey is pressed, the entry area of the display will show the currently defined signal frequency and present a prompt to change it as desired. Once this softkey has been pressed, the instrument will assume that all measurements made in the CW mode on the setup sensor are at the specified CW frequency. The instrument will correct the power readings of the sensor according to the frequency correction table stored in the sensor's PROM.

[CW CAL FACTOR]

Menu SY1-2: Specifies user-defined sensor frequency response correction factors. When this softkey is pressed, menu SY1-4 will be shown allowing the selection of the sensor to which the cal factor will be applied. Once the selected sensor is specified, the instrument will apply the cal factor to all CW measurements made with the sensor, and the frequency correction table stored in the sensor's PROM will not be used when in the CW mode.

[FROM SOURCE]

Menu SY1-2: Specifies that the 8003 should automatically determine the frequency of the signal from the signal source. Pressing this softkey will cause menu SY1-5 to appear wherein either all or any individual sensors can be selected to determine the source's CW output frequency as set by the 8003 through the source control keys.

[CORRECTN OFF]

Menu SY1-2: Accesses menu SY1-6 wherein the correction factor for either all or any individual sensors can be turned off.

[SENSOR OFFSET]

Menu SY1: Causes menu SY1-7 to appear. This menu either clears or enters offsets for the selected sensors. When the selected SENSOR OFFSET softkey is pressed, the entry area of the display will show the current value of the setup sensor's offset. The offset can then be changed as desired.

The SENSOR OFFSET softkeys of menu SY1-7 will be in light blue if the setup sensor's offset is nonzero. If the sensor offset is zero, the softkey label will be in standard menu green since no offset is being used.

[PULSE SENSORS]

Menu SY1: Accesses menu SY1-8 and then SY1-9 wherein channel and operating modes can be specified when any of the 80340 Series of Triggerable Pulse (Peak Power) Sensors are used with the 8003. The channel of interest is first selected and then either the Free Run, Trig'd, or Delay Trig'd mode is specified in menu SY1-9. In the Free Run mode, the RF power is sampled automatically and the sensor does not require a trigger signal. In the Trig'd mode the sensor measures the RF power when a trigger signal is applied, and in the Delay Trig'd mode the sensor will sample the RF power at some specific time later than the trigger.

See the Operation & Maintenance Manual included with the Triggerable Pulse (Peak Power) Sensors for complete operating information.

[GPIB DEVICES]

Menu SY1: Accesses menu SY1-10 wherein the GPIB address for the 8003 can be set and the instrument's private bus can be turned on or off. The [SOURCE] softkey of menu SY1-10 accesses menu SY1-11. The [SOURCE ADDRESS] softkey of menu SY1-11 sets the address of the signal source (default is 20). The [AUTOSELECT] softkey automatically interfaces any compatible sweeper being used in the system with the exception of a Model HP8350A. If an 8350A is being used the next softkey down, labeled HP 8350A, should be pressed to activate the interface. The [PLOTTER] softkey of menu SY1-10 brings up menu SY1-12. Through this menu the plotter's address can be set (default is 05), and the number of pens the specific plotter contains can be defined for use by the 8003 when graphic plots are made. The [PRINTER ADDRESS] softkey of menu SY1-10 sets the address of the printer being used in the system (default is 01).

[CAL SWP RAMP]

Menu SY1: Synchronizes the 8003 to the ramp from the sweeper. This will need to be done if the trace length on the display is less than the full 8 horizontal divisions.

[STANDARD]

Menu SY1-A: Resets the 8003 to normal (default) operation after the V_{PROP}^F function has been used.

[V_{PROP}^F]

Menu SY1-A: Synchronizes the internal measurement process to an external ramp signal.

[SERVICE]

Menu SY1: Accesses function testing of various elements of the 8003. This will aid in the maintaining and servicing of the instrument. This softkey causes menu SY1-13 to appear. The regular data display will be replaced with a display of the currently defined calibrator output adjustment and the currently defined serial number of the calibrator.

[SET CAL]

Menu SY1-13: Adjusts the 0 dBm output of the calibrator of the 8003. When this softkey is pressed, the softkey menu will change to menu SY1-14 where the calibrator output and the calibrator serial number can be revised or modified if required. A password can be defined that must be entered to enable the adjustment of the calibrator output (see DEFINE PASSWORD next page). This will be for environments in which access to this ability must be restricted. If a password is defined for this adjustment function, then all the softkey labels except for the ABORT label will be in dim, dark blue and cause no action if their associated softkeys are pressed. The instrument will present a prompt to enter the password. If the correct password is not entered, the instrument will deny access but will allow the entry to be tried again.

If the password is entered correctly or no password has currently been defined, then all of the softkey menu labels will be in standard menu green.

[SET CAL OUTPUT]

Menu SY1-14: Sets the calibrator output. When this softkey is pressed, the presently defined value of the calibrator adjustment (in percentage of deviation) will flash and a prompt will be presented asking for a new adjustment percentage to be entered as desired. A number from 50.00 to 150.00 (%) can then be entered.

[SET CAL S/M]

Menu SY1-14: Defines the calibrator serial number. When this softkey is pressed, the presently defined calibrator serial number will flash and a prompt will be presented asking for a new serial number to be entered as desired. Any number up to eight digits in length can then be entered by using the 0 through 9 number keys

[DEFINE PASSWORD]

Menu SY1-14: Defines a password that users will have to enter to change the calibrator output. When this softkey is pressed, a prompt is presented asking for a new password. Six number keys can then be pressed. The keys being pressed will not be shown on the display. Once the six number keys have been pressed, the display will again present a prompt asking that the password just defined be entered again to confirm the password. When the password is confirmed, the defined password will be enabled.



NOTE: Jumper W1 on the Calibrator PC Board must be moved to pins 2 and 3 from pins 1 and 2 to complete the enabling of password protection.

[CLEAR PASSWORD]

Menu SY1-14: Clears the password. Once this softkey is pressed, the password will be cleared and future users will be able to adjust the calibrator output without having to know a password until one is again defined.

[ABORT]

Menu SY1-14: Abandons any changes made to the calibrator output adjustment. When this softkey is pressed the routine will return to the SET CAL softkey of menu SY1-13. Any changes that may have been made to the calibrator output and/or the calibrator serial number and/or the password since entering the SET CAL menu will be reversed.

When the SET CAL softkey menu is displayed, it will only be possible to leave the menu and return to regular data display by pressing the [ABORT] or [DONE] softkeys.

[DONE]

Menu SY1-14: Terminates the setting of the calibrator output. The calibrator output adjustment and the calibrator serial number will be remembered as they appear at the time the softkey is pressed. The 8003 will also memorize the time when the DONE softkey is pressed as the new calibration time. The instrument will return to the SET CAL softkey of menu SY1-13.

[SET TIME]

Menu SY1-13: The 8003 contains a real time clock with a battery backup so that it retains the time and date at power off. The SET TIME softkey sets the clock time and date. When the softkey is pressed, the regular data display will be replaced with a display of currently defined time and date. Menu SY1-15 will also appear allowing you to set the hour, minute, second, date, month and year. Setting of the hour, minute, and second of the clock is done using 24-hour time, 0:00:00 to 23:59:59. Years are defined by four digits.

The [DONE] softkey at the bottom of the menu terminates the setting of the clock. The clock will start running from the time and date settings that appear at the time this softkey is pressed. The routine will then return to the SET TIME menu (SY1-13).

When the [SET TIME] softkey is displayed, it will only be possible to leave the menu and return to regular data display by pressing the DONE softkey.

[TEST PATTERN]

Menu SY1-13: Displays various test patterns. The patterns will provide helpful feedback when making adjustments to the display hardware. The data display will be replaced with a test grid, and the softkey menu will change to SY1-16.

When the TEST PATTERN softkey menu is displayed, it will be possible to only leave the menu and return to regular data display by pressing the DONE softkey.

Whatever softkey label is currently associated with the display pattern being shown will be in light blue. All other labels will be in standard menu green. If a front panel key is pressed, the screen will display the name of the key.

[GRID L/S] and [DOTS L/S]

Menu SY1-16: Replaces the entire display with the indicated display pattern. A prompt on the screen will be shown indicating that any key can be pressed to return to the menu. When the key is pressed, the routine will return to the TEST PATTERN menu (SY1-13) with the exception that the indicated pattern will continue to occupy the data display area.

[COLOR BARS]

Menu SY1-16: Replaces the data display area with a standard NTSC color bar display.

[CIRCLES and 1 COLOR]

Menu SY1-16: Selects displays which can be used for making adjustments to the video circuits of the 8003.

[CHANGE COLOR]

Menu SY1-16: Changes the color of the pattern being displayed. When the [TEST PATTERN] softkey in the Service Menu is pressed and the Test Pattern menu entered, the test grid will be light blue. Changes in color will be cycled in the following order: Red, Yellow, Green, Light Blue, Dark Blue, Magenta, and White.

[DONE]

Menu SY1-16: Terminates the display of test patterns. The routine will return to the Test Pattern menu (SY1-13).

[SENSOR EEPROM]

Menu SY1-13: Enters the routines necessary to either view or change the calibration data for the power sensors and/or bridges connected to the 8003.

8003 Precision Scalar Analyzer

This softkey will bring up menu SY1-17. The available selections will be shown in standard menu green. Non-available selections will be in dim, dark blue. In this menu, dim, dark blue generally indicates that a sensor is not connected to an input.

To continue, select sensor A, B, or C. The display will change to show a calibration spreadsheet for the selected sensor. The softkey menu will change to menu SY1-18.

[PAGE UP]

First Level Menu SY1-18: Accesses menu SY1-19. When [PAGE UP] is first pressed, the spreadsheet will go to page 2 and the menu will change to SY1-19.

[PAGE UP] and [PAGE DOWN]

Second Level Menu SY1-19: Pages through the tables of calibration data to examine/change entries. The bottom line of the screen displays new data as it is entered on the keyboard. To change a data value in the table, move the yellow bar to the appropriate line using either the spin knob or by repetitive entries on the UNITS keys (MHz/dBm or GHZ/dB). Enter the new value using the keypad and the appropriate terminator key.

Subsequent operation of [PAGE UP] will continue to increment to the last page of data.

Use [PAGE DOWN] to return to an earlier page in the sequence.

[FIRST PAGE] and [LAST PAGE]

Menu SY1-19: These softkeys directly access the first and last pages, respectively, of the calibration data.

[ENABLE INPUT]

Menu SY1-19: The default condition of the 8003 is for data input to be enabled. This can be defeated using [ENT/OFF]. To re-enable, use [ENABLE INPUT].

[SET TIME]

Menu SY1-18: This softkey functions the same as [SET TIME] described on page 2-62.

[CAL LOC]

Menu SY1-18: Selects the location at which the calibration was performed. The choices are shown in menu SY1-21. The CAL LOCATION is shown on page 1 of the sensor identification spreadsheet.

[PASSWORD]

Menu SY1-18: Toggles the requirement for entry of a password before any changes can be made to the sensor calibration stored in the EEPROM. The [PASSWORD] softkey accesses menu SY1-22.

[DEFINE PASSWORD]

Menu SY1-22: Defines a password that users will have to enter to change the sensor calibration data stored in the EEPROM.

When this softkey is pressed, a prompt is presented for a new password. Six number keys should then be pressed. The keys being pressed will not be shown on the display.

Once the six number keys have been pressed, the display will again present a prompt asking that the password just defined be entered again for confirmation. When the password has been confirmed, the defined password will then be accepted.

Then press [RETURN] and [PROGRAM EEPROM] to store the password in the sensor EEPROM. From this point on, the password must be entered before any calibration data can be changed in the sensor EEPROM.

[CLEAR PASSWORD]

Menu SY1-22: Clears the currently defined password. This can be done as follows by pressing:

[CLEAR PASSWORD] [RETURN] [PROGRAM EEPROM] enter the password [PROGRAM EEPROM]

The password will then be erased from the sensor EEPROM. Future users will be able to change the data in the sensor EEPROM without having to enter a password until one is again defined.

[PROGRAM EEPROM]

Menu SY1-18: Downloads new sensor calibration information to the sensor EEPROM which will replace all changeable data currently stored in the EEPROM. In this respect the 8003 functions as a PROM programmer, thus removing the need for any additional test equipment.

This softkey accesses menu SY1-23. You should enter either [PROGRAM EEPROM] in this menu to continue, or [RETURN] to cancel.

[ENABLE INPUT]

Menu SY1-18: The default condition of the 8003 is for data input to be enabled. This can be defeated using the [ENT/OFF] key. To re-enable, use the [ENABLE INPUT] softkey.

[ABORT]

Menu SY1-18: Pressing [ABORT] will bring up menu SY1-24. The [ABORT PROGRAM] softkey in this menu exits back to menu SY1-17. The [RETURN] softkey cancels the ABORT instruction.

2.8 Front Panel Operation

The instructions in this section will take you in a step-by-step sequence through the procedures used in the basic setup and operation of the instrument. This will prepare you for making the specific types of measurements described in succeeding sections. The discussion assumes that you are using the 8003 Precision Scalar Analyzer with a supported microwave sweeper, a Series 803XXA power sensor, and a Series 80500 return loss bridge.

Configure the analyzer and sweeper according to the instructions in Section B.3. Connect one power sensor to sensor input A. Connect the bridge to sensor input B. Leave sensor input C disconnected.

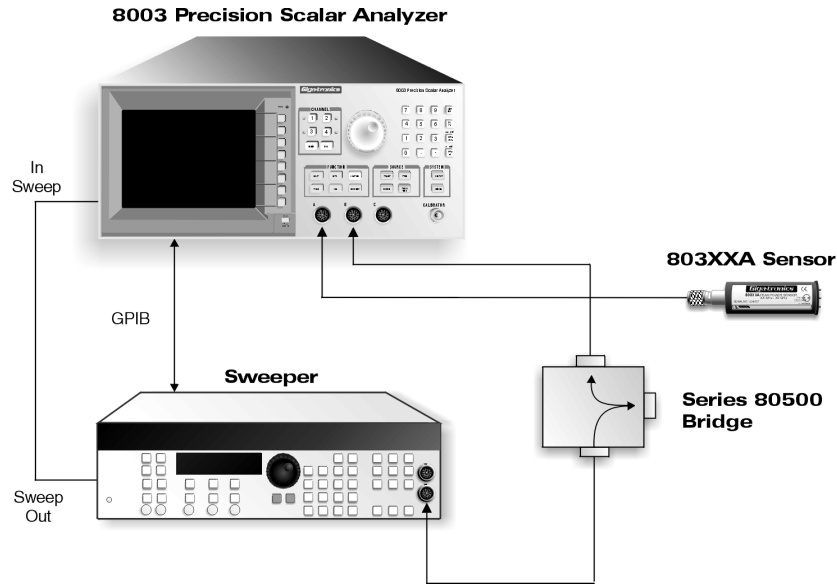

Figure 2-18: Analyzer, Sweeper, Sensor & Bridge Interconnection

Turn on the sweeper first, and then the analyzer. The analyzer will perform its start-up self test and initialize the sweeper. Press **[PRESET]** on the 8003 Precision Scalar Analyzer to bring up the preset (default) conditions.

2.8.1 Calibrating for Power Measurement

Before the 8003 analyzer can operate, the Power Sensor and Bridge must be calibrated. Connect the power sensor to the 8003 analyzer front panel connector marked **CALIBRATOR**. You may need to use an adapter to adapt from the sensor connector to the front panel type N(f) connector. Press Function **[CAL]** and look at the softkey menu.

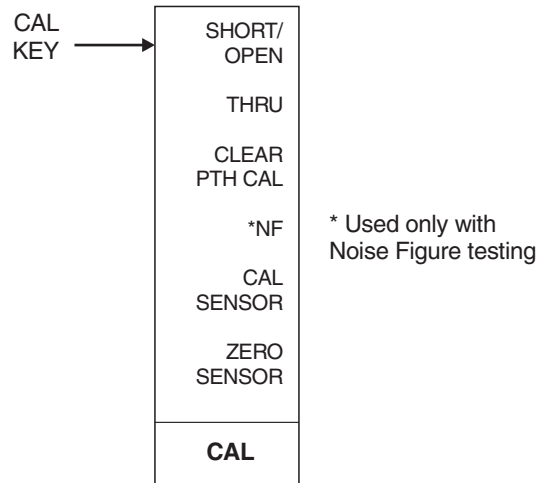

Figure 2-19: CAL Softkey Menu

Press **[CAL SENSOR]** to bring up a menu of sensors to be calibrated.

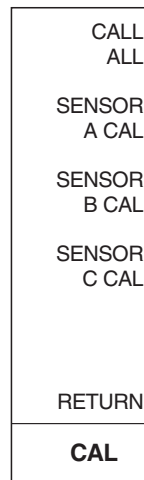

Figure 2-20: Sensor CAL Menu

8003 Precision Scalar Analyzer

Press [**SENSOR X CAL**], where X is the correct sensor input (A, B, or C). As the sensor calibrates you should see a display develop that looks something like Figure 2-21 when the calibration has completed.

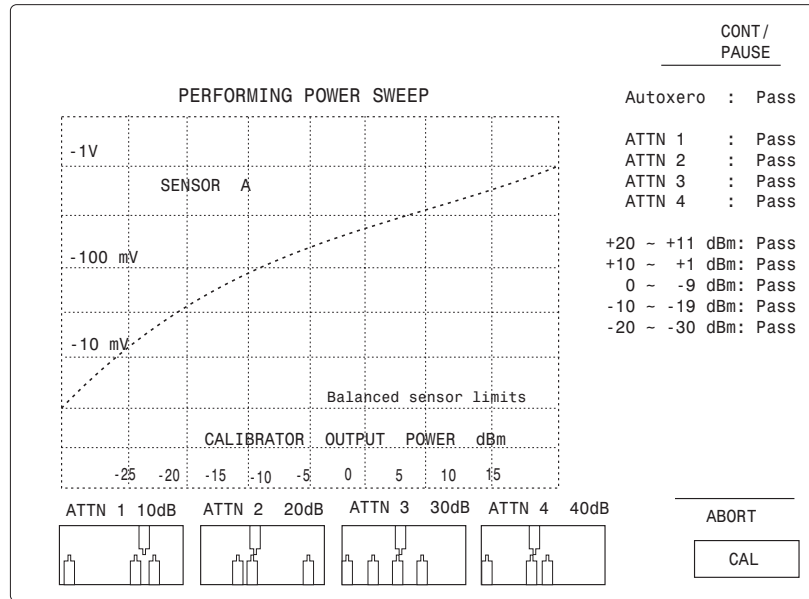

Figure 2-21: Sensor Calibration Display Screen

Upon successful calibration the instrument will chime and return to its standard display. If the instrument should fail to calibrate, make sure that your sensor is properly attached to channel A and that it is tightly attached to the calibrator before assuming that there is something wrong with the sensor. Also, make sure that you have the proper sensor cable (see Section B.3.2).

Disconnect the sensor from the calibrator and connect the Input Port of the bridge to the calibrator. Either leave the test port of the bridge open, or connect a short to the test port. Although leaving the test port open will give adequate results, for best accuracy, connect a short to the test port of the bridge. Press [**SENSOR B CAL**] to calibrate the bridge. Again, the instrument will chime upon successful completion of a calibration and return to its standard display. If the instrument should fail to calibrate, check your bridge connections and sensor cable before assuming that the bridge is bad.

2.8.1.1 Calibration Intervals

Normally, front panel calibration of sensors and bridges should be done whenever the analyzer is powered up - at least once per day. The linearity calibration is very stable and is memorized by the analyzer in non-volatile memory so that calibration data is not lost when the analyzer is turned off. Once calibrated, the sensors should remain in calibration for days. However, daily calibration is recommended as good measurement practice.

There are some conditions under which it is advisable to recalibrate the sensors. The most common is a significant change in ambient temperature. This is not a problem in most temperature controlled manufacturing and engineering environments. However, if the ambient temperature has changed more than 10 degrees Fahrenheit (± 5 degrees Celsius) since the last calibration, you may want to recalibrate the sensors. Another good time to recalibrate the sensors is if you suspect they have been damaged. This can either be due to electrical damage (subjecting the sensor to more than its maximum rated power or more than its rated input dc voltage), or mechanical damage (for instance, dropping the sensor). If the sensor calibrates normally, changes are that it was not damaged seriously. Although the analyzer is capable of calibrating out minor variations due to electrical or mechanical mistreatment, internally set limit lines prevent the unintended use of badly damaged sensors.

2.8.2 Path Calibration Correction for Component Variations

These procedures explain how to perform path calibration corrections for component variations. Connect the input port of the bridge to the RF Output connector of the sweeper. You may need an adapter to adapt the sweeper to the bridge.

Configure the analyzer for your measurement. First, turn off channels 3 and 4. Press Channel **[3]**. Then press the **[OFF]** key. This should remove the channel 3 trace and its associated information area. Turn off channel 4 in the same way.

2.8.2.1 Set Up Sweep Parameters

Press the Source **[START]** key. Enter the desired start frequency on the numeric entry pad, and press the correct units key (MHz or GHz). The frequency indicators at the bottom of the analyzer display as well as the frequency display on the sweeper should indicate your new start frequency.

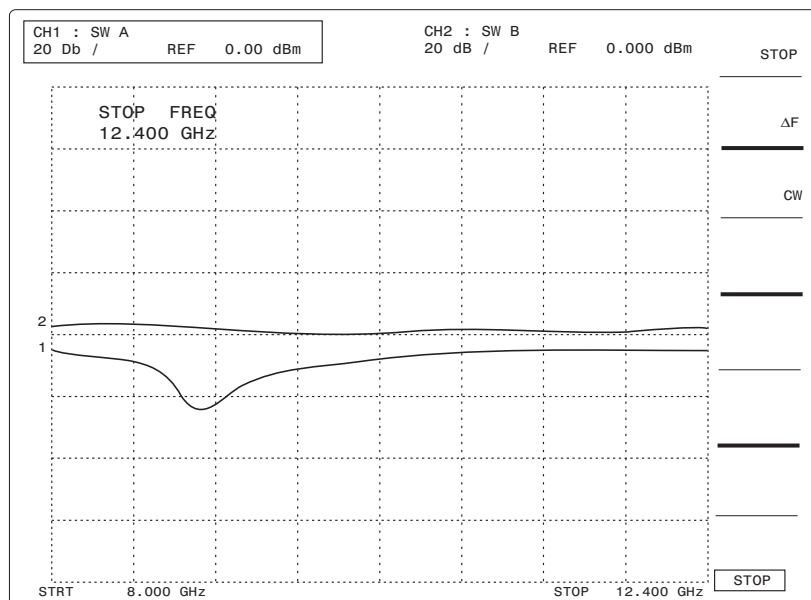

Figure 2-22: New Frequency Parameters Display Screen

If the sweeper does not respond to the new Start frequency, check that the GPIB cable from the analyzer to the sweeper is properly connected. Also check that both the analyzer and the sweeper agree on the sweeper GPIB address (see the Sweeper Installation in Section B.3.3 for more details).

In the Source section, press **[STOP]** and enter the stop frequency. Press **[POWER]** and enter the desired RF power level (often the maximum leveled power from the sweeper). Locate the **[RF POWER ON/OFF]** softkey. The OFF characters are in light blue indicating that RF Power is currently set to OFF. Press this softkey and notice that the ON characters become light blue, and that the RF power from the

8003 Precision Scalar Analyzer

sweeper turns on. Press **[SWEEP TIME]** and enter the desired sweep time on the numeric entry pad, and press the appropriate units key (ms or s) (0.5 second is recommended initially).

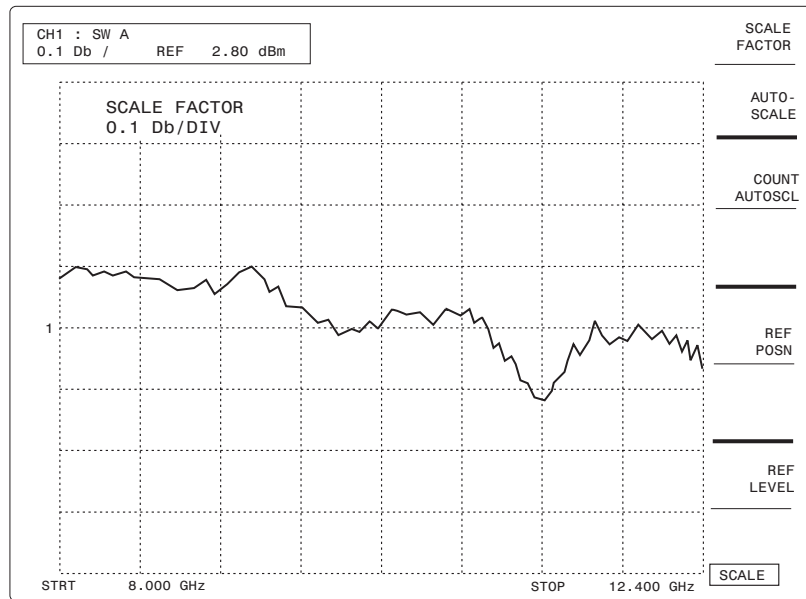

Figure 2-23: Autoscaled thru Path Before Path Calibration Display

2.8.2.2 Frequency Response Correction

Connect the power sensor to the test port of the bridge. The channel 1 trace (light blue) is now indicating the power output at the bridge test port as a function of frequency. Because the analyzer is currently set to a vertical scale of 20 dB/division, the trace probably looks like a straight horizontal line. To change the vertical scale factor, press Function **[SCALE]** then press **[AUTO-SCALE]**. The analyzer automatically scales the trace to show maximum vertical variation on the screen.

The variation on the screen is due to the residual leveling errors from the sweeper as well as frequency variations in the bridge, adapters, and connectors. These variations must all be taken into account when making a component measurement. One of the easiest ways to do this is by letting the analyzer memorize the variations and automatically subtract them out of the measurement. This is known as a Path Calibration since it calibrates out the frequency variations in each measurement path.

To do a path calibration, press Function **[CAL]** then press **[THRU]** which brings up the F4-2 menu in Figure 2-24.

STORE THRU A
STORE THRU B
STORE THRU C
A FULL BND Y/N
B FULL BND Y/N
C FULL BND Y/N
RETURN
CAL

Figure 2-24: THRU PATH Calibration Menu

8003 Precision Scalar Analyzer

Press [**STORE THRU A**]. The analyzer will display the message **PREPARING SOURCE FOR 'A' THRU**. When it is done, the analyzer will display **'A' THRU PATH CAL DONE**. Press [**SCALE**] then [REF LEVEL], and then press the digit **0** on the numeric keypad followed by the [**GHz/dB**] units key. You should now see a straight line trace in the middle of the screen. If the resulting line has more than ± 0.1 dB of ripple, press [**A FULL BND Y/N**]. The 'Y' should turn dark blue, and the 'N' should be light blue. This causes the sweeper to perform a path calibration over the displayed range instead of the full frequency range of the sweeper. Press [**STORE THRU A**] to path cal again. You should get a straight line trace. The analyzer is now ready for fully corrected, accurate insertion loss measurements.

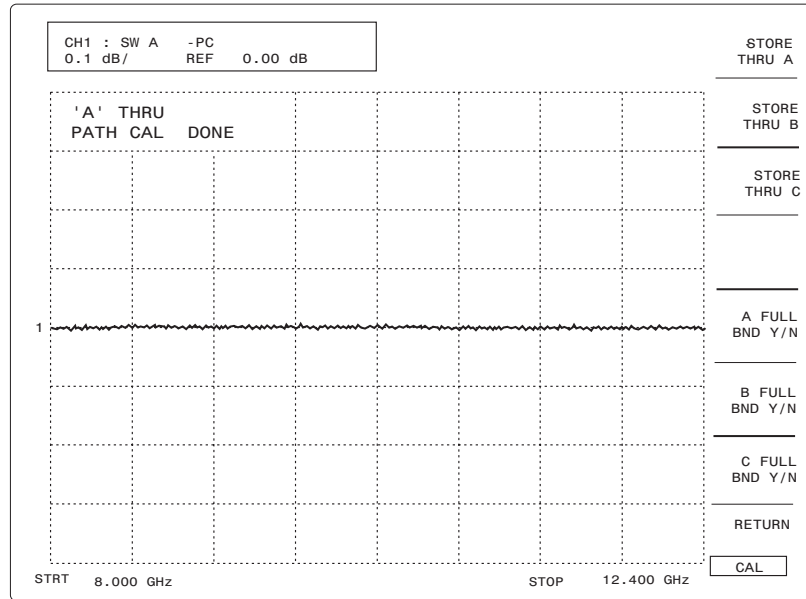

Figure 2-25: Calibrated Path Display

Remove the power sensor from the bridge. Attach a short to the bridge test port. Press Channel [**2**] to make channel 2 the active entry channel. Note on the analyzer screen that the box around the channel 1 summary area now moves around the channel 2 summary area to indicate that it is the active channel. The channel 2 trace shows the reflected power coming back from the test port. To calibrate out the frequency variations in the reflected path, press Function [**CAL**], then press [**SHORT/OPEN**] followed by [**STORE SHORT B**]. After the analyzer calibrates with the short, it will ask you to connect an open

to the bridge test port. Connect an open to the bridge test port and press [STORE OPEN B]. When the analyzer finishes this calibration, it is ready to make fully corrected, accurate reflection measurements.

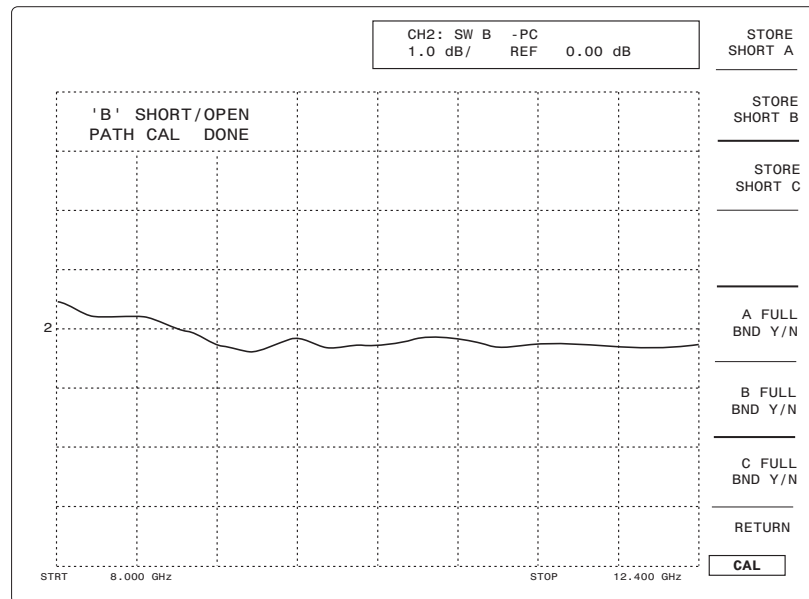

Figure 2-26: Successful SHORT/OPEN CAL Display w/ Open Attached

2.8.3 Making a Device Measurement

Disconnect the OPEN from the bridge test port. Connect the device or component you will be measuring between the bridge and the power sensor. Make channel 1 the active entry channel by pressing Channel [1]. Scale the channel 1 (insertion loss) trace by pressing the [SCALE] key and the [AUTO-SCALE] softkey. Scale the channel 2 (return loss) trace by selecting it as the active entry channel and pressing [AUTO-SCALE].

Insertion and Return loss can be read directly from the display or by using the cursor. To activate the cursor, press the Function [CURSOR] key. A cross (+) on each trace shows the current cursor position. The parameters for the cursor on the active entry channel are read out in the active entry area of the display. By turning the spin knob, the insertion loss or return loss can be read at any frequency point on the display.

8003 Precision Scalar Analyzer

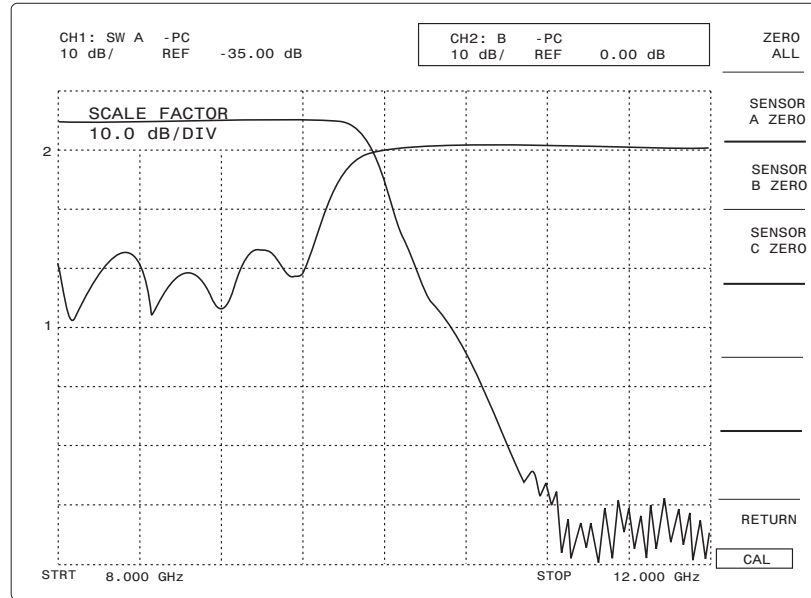

Figure 2-27: Device Measurement Plot (Typical Display)

You should now be familiar with the basic operation of the 8003 Precision Scalar Analyzer. Refer to Chapter 3 for remote operating instructions via the GPIB.

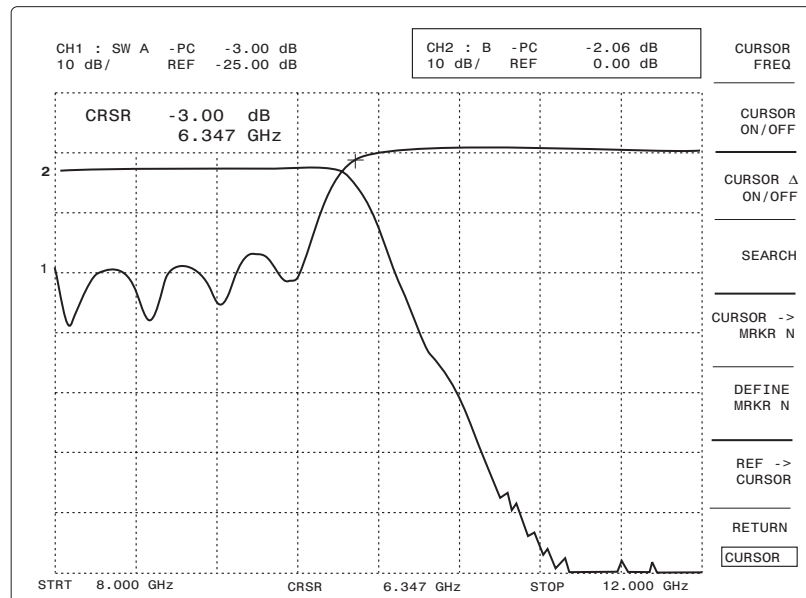

Figure 2-28: Cursor Plot Typical Display

2.9 Insertion & Return Loss Measurements

This section defines how to configure your signal splitting components to make accurate insertion and return loss measurements on a device or component. Depending on how you configure your measurement accessories, you must DEFINE a channel path and choose how you will MEASURE your device against stored calibration or trace data.

2.9.1 Single-Sensor Insertion Loss Measurement

The simplest insertion loss measurement consists of just measuring the power gain or loss at the output of your Device Under Test (DUT).

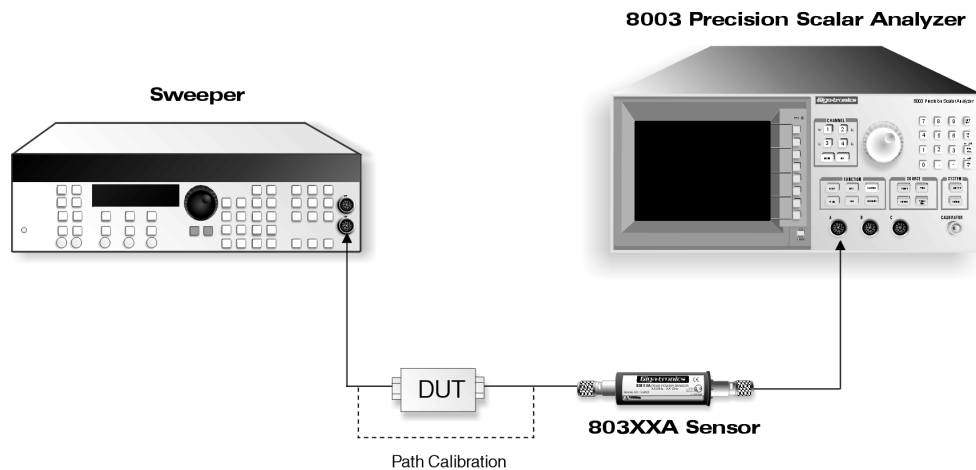

Figure 2-29: Swept Source & Power Sensor Only Block Diagram (w/ DUT)

In this simple measurement, first choose a channel to be the Insertion Loss channel. Then press the **[DEFINE]** key to bring up the **[DEFINE]** softkey menu. Select the **[SINGLE SENSOR]** softkey and choose the sensor to be used for that channel (A, B, or C). The displayed trace now indicates true or absolute power measured by the sensor.

An insertion loss measurement typically compares the ratio of the power out of the DUT to the power into the DUT. In a single sensor measurement, this is normally done by first measuring the swept power into the device and storing that result. This is called path calibration or path cal. This stored path cal is then ratio'ed with the power measured out of the DUT. In the softkey menu, the selection **[MEASURE ABS PWR/PTH CAL]** function determines whether the analyzer measures absolute power (ABS PWR) or ratio's the reading with the stored path (PTH CAL). The actual path calibration is done via the CAL front panel key and the THRU softkey, with the sensor bypassing the DUT and connected directly to the swept source, as shown in Figure 2-29.

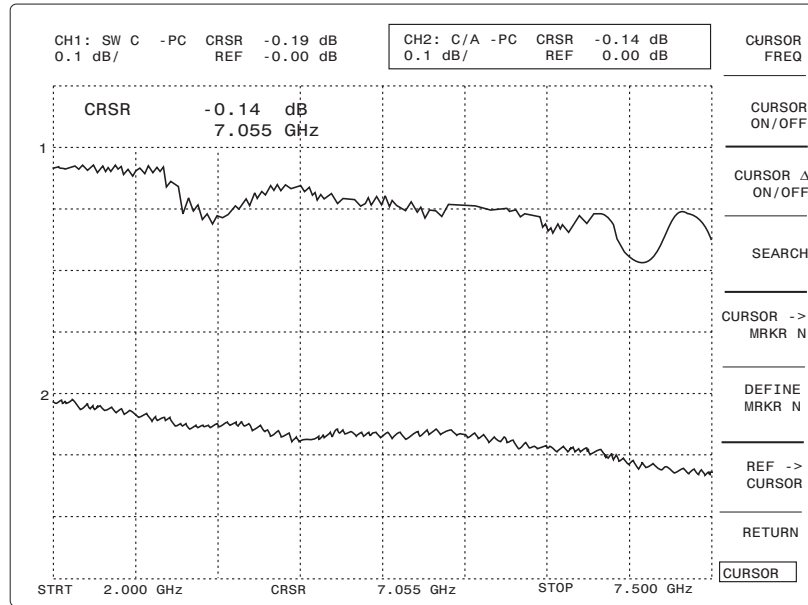

Figure 2-30: More Accurate Insertion Loss Ratioing Meas. (Back-to-Back Adpts. Improving Source Match)

2.9.1.1 Using Channels

The analyzer can display up to four channels simultaneously.



The display on each channel is completely user determined and independent of the number of sensors and/or bridges being used. For example, all four channels display power readings from the same single sensor. This might be particularly useful if the scale factors were different for each of the four channels so that different characteristics of the same trace (such as filter skirts and pass band ripple) could be highlighted. Actually, each channel can display a user-defined mathematical relationship, such as the ratio of the power readings from two sensors minus the stored path calibration. To define this relationship, you must choose a channel button, press the **[DEFINE]** key, and choose between single sensor measurements, or the ratio or difference between any two sensors. By pressing **[MEAS]**, you can also choose to subtract path cal and/or stored trace data from the measurement.

The channel selection buttons have the secondary function of selecting the Active Entry channel. This is indicated by an LED that lights next to the selected channel as well as a box drawn around the channel summary area at the top of the screen. The Active Entry channel is the one that is modified by any of the analyzer function keys (such as scale factor or cursor keys).

2.9.2 Two-Sensor Insertion Loss Measurements

The basic two-sensor insertion loss measurement consists of monitoring the power incident upon the DUT, and comparing it to the power exiting the DUT. Incident power can be monitored in a variety of ways, but the two most common are to use a Power Splitter or Directional Coupler, shown in Figures 2-31 and 2-32.

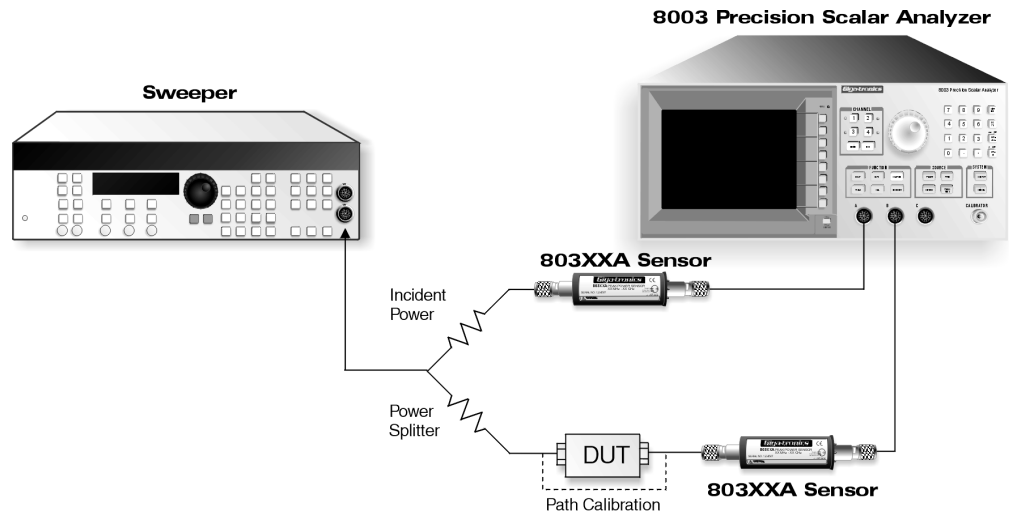

Figure 2-31: Two Sensor Insertion Loss Setup w/ a Power Splitter

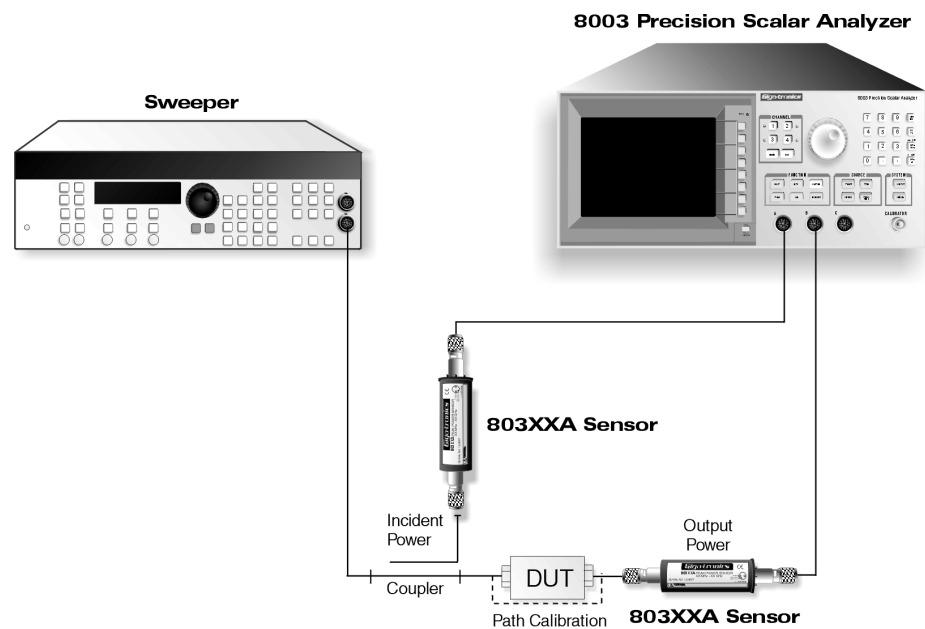

Figure 2-32: Two Sensor Insertion Loss using a Directional Coupler

Power splitters have the advantage of wide frequency range, typically from dc to tens of Gigahertz. However, power splitters typically have an insertion loss of at least 6 dB. Directional couplers with an insertion loss typically less than 1 dB are used when insertion loss is a concern. However, wide frequency coverage is often more difficult and expensive than with power splitters.

In a two-sensor measurement, the power ratio of the two sensors is displayed as the measurement. After pressing the **[DEFINE]** key, the **[RATIO]** softkey allows you to choose the proper ratio. The numerator, or first sensor selected, should be the sensor monitoring the power out of the DUT. The denominator, or second sensor selected, should be the sensor measuring incident power (power into the DUT). As with single-sensor measurements, the two-sensor measurement compares the measured power ratio through the DUT with a path calibration power ratio without the DUT. The **[ABS PWR/PTH CAL]** softkey determines whether the analyzer just ratio's the absolute power measured by the sensors (ABS PWR), or also ratio's with a stored path calibration (PTH CAL).

The actual path calibration is a little different from single-sensor measurements. You must do two path calibrations, one for each sensor. The reason is that the analyzer memorizes each sensor's path cal in separate memories. This saves time when a sensor is used on more than one channel. For instance, suppose channel 1 displays the ratio A/B, channel 2 displays sensor A power, and channel 3 displays sensor B power. A path cal of sensor A and sensor B is then enough data to calibrate all three channels. To path cal the two sensors, press the **[CAL]** key to bring up the softkey menu on the screen. Press the **[THRU]** softkey. Now press the **[STORE THRU X]** softkey for the two sensors you are using for this measurement.

Single-Sensor vs Two-Sensor Measurements

Single-sensor insertion loss measurements have the advantage of being very simple to configure with little or no extra equipment required. As long as the source output level is repeatable from sweep to sweep, and path cal is used, the measurement can be very accurate. However, it does require that the power from the source does not change between path cal and measurement — something which may be a problem if the source power changes with load match, or if the measurement requires swept power levels (such as amplifier 1 dB compression measurements).

A two-sensor ratio can improve the accuracy of an insertion loss measurement by reducing the error due to source mismatch. In any practical measurement, some power from the source is reflected back to the source by the device under test. Any mismatch at the source causes some of this signal to be reflected back to the device under test. The reflected signal looks like a variation in the incident power, which would lead to errors in a single-sensor measurement. With two sensors, the incident sensor monitors the same variations (due to reflected signals) from the source, that the output sensor measures. The ratio of output to incident power therefore cancels the effect of source reflections. In practice, this cancellation is not perfect but leads to a much improved effective source match.

Two-channel insertion loss measurements are also useful for measurements requiring sweeper power changes such as amplifier or mixer 1 dB compression point. In a typical gain compression measurement, the sweeper power level is ramped from the small signal region of the DUT to its saturation level. With two-sensor measurements, both the incident and output sensor monitor the changing sweeper levels. The ratio of output to incident power is then always the true gain of the amplifier. At some point, the amplifier or mixer goes into compression and the gain rapidly decreases. The output level where the gain decreases by exactly 1 dB is the 1 dB compression point of the amplifier (a second analyzer channel can display just the power from the sensor connected to the amplifier output; the 1 dB compression power).

2.9.3 Single-Sensor Return Loss Measurements

There are two types of single-sensor return loss measurements; one using a return loss bridge, and one using a directional coupler. Both types use exactly the same operating procedure. Return loss bridges are more common because of their broad frequency range and very good directivity. Figures 2-33 and 2-34 show typical examples of test setups using bridges and couplers.

In a return loss measurement, the bridge or coupler is connected between the sweeper and DUT. A power sensor either built into the bridge or attached to the coupler then monitors power reflected back from the DUT. The ratio of the power incident on the device to the power reflected from the device is the return loss.

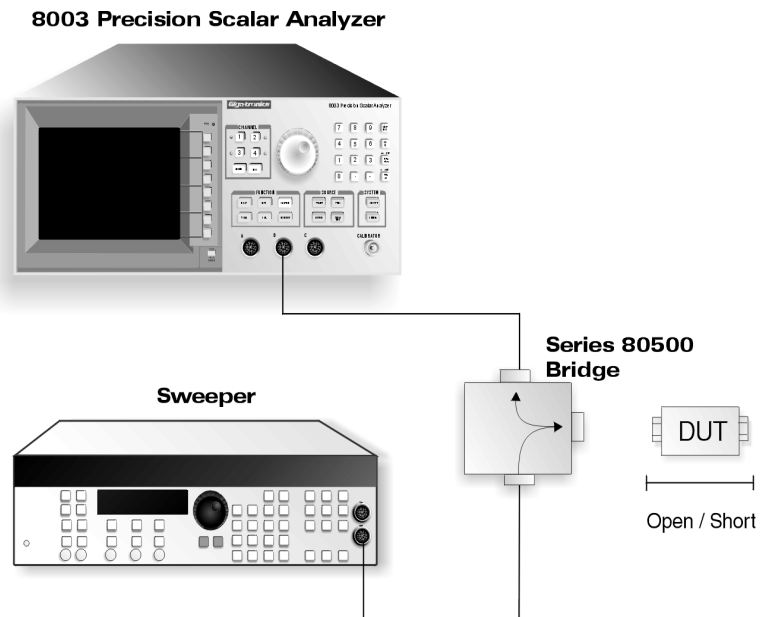

Figure 2-33: Return Loss Setup Using a Bridge

8003 Precision Scalar Analyzer

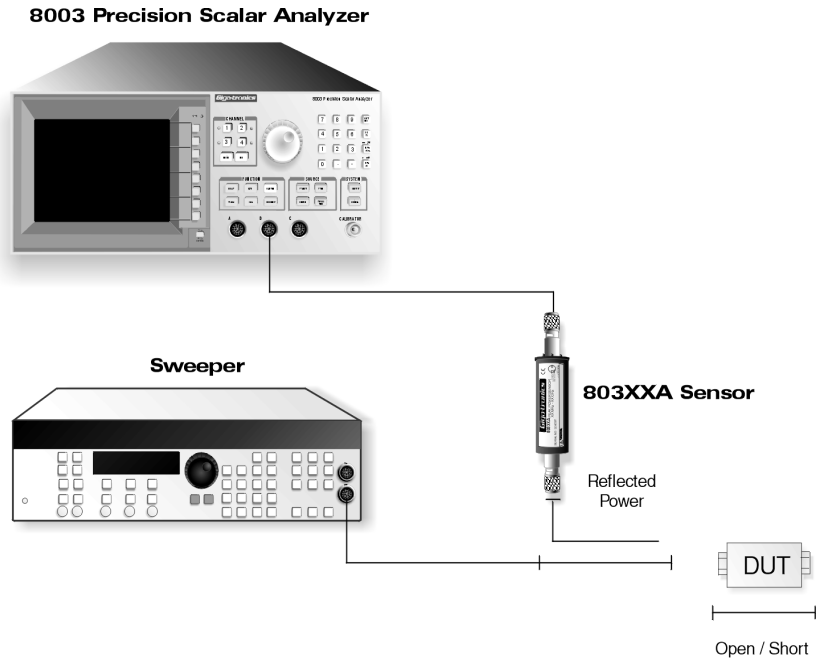

Figure 2-34: Return Loss Test Setup Using a Directional Coupler

In a single-sensor return loss measurement, the incident power is measured during path calibration and stored by the analyzer. It is then subtracted from the measured reflected power (subtracting dB's is equivalent to ratio'ing Watts). To set up the analyzer to make a single sensor return loss measurement, first choose a channel to be your return loss channel. Then press the **[DEFINE]** key to bring up the DEFINE softkey menu on the screen. Press the **[SINGLE SENSOR]** softkey and choose the sensor that will be measuring the reflected power. Since path calibrations will be used, press **[MEAS]** and toggle the **[ABS PWR/PTH CAL]** softkey until **[PTH CAL]** is active (light blue color).

To path cal the channel, first connect a short to the bridge or coupler test port. This will cause all of the sweeper power to be reflected back to be measured by the reflected sensor - accounting for bridge or coupler path losses. Press **[CAL]** and the **[SHORT/OPEN]** softkey. Then press the **[STORE SHORT X]** softkey that corresponds to the sensor measuring the reflected power. Once the Short cal is done, connect an OPEN to the bridge or coupler test port. Press the **[STORE OPEN X]** softkey to complete the calibration.

NOTE: *The most accurate return loss calibration is the short/open calibration. It is possible to calibrate the bridge or coupler with only a short or only an open - although with degraded accuracy.*

Like insertion loss measurements, the single-channel return loss measurement is accurate as long as a path cal is made and the sweeper power does not change. However, a two-sensor return loss measurement can give better accuracy by improving the effective source match of the sweeper. See the two sensor insertion loss in Section 2.9.2 for a more detailed explanation.

2.9.4 Two-Sensor Return Loss Measurements

In a two-sensor return loss measurement, a power splitter or directional coupler is inserted between the return loss bridge or reflection directional coupler to monitor incident power.

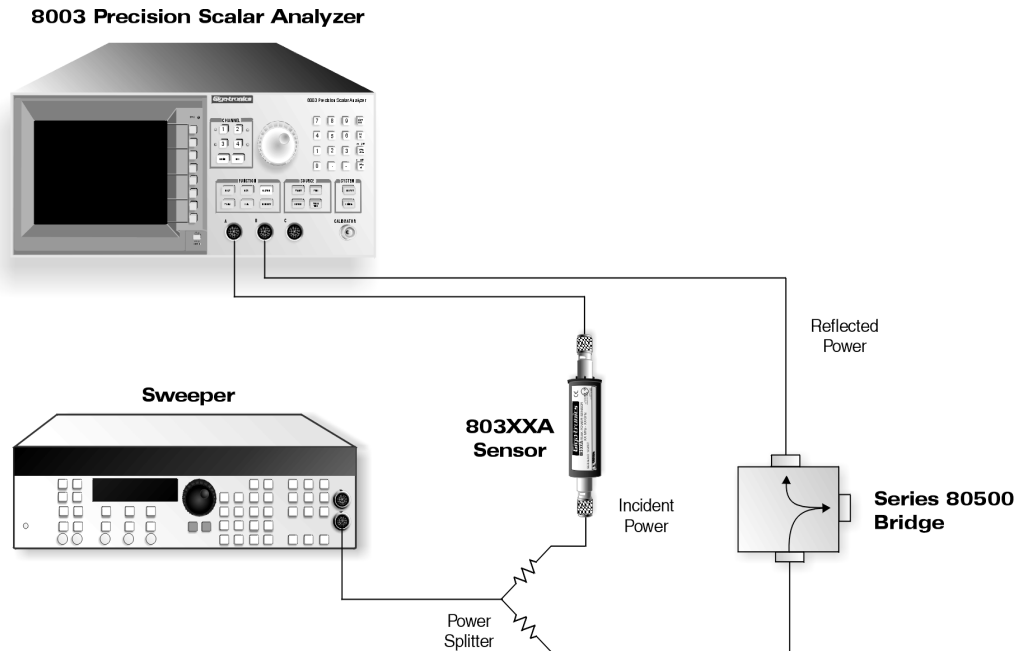

Figure 2-35: Two Sensor Return Loss Setup Block Diagram

The ratio of the reflected to incident power with the path cal subtracted then properly indicates return loss. Because the two sensor configuration measures return loss directly as a ratio, it is insensitive to sweeper power changes. As with 2 channel insertion loss measurements, press **[DEFINE]** followed by the **[RATIO]** softkey, followed by the sensor measuring reflected power, followed by the sensor measuring incident power. Path calibration must be done twice, once for each sensor used.

8003 Precision Scalar Analyzer

2.9.5 Three-Sensor Configurations

Three-sensors typically measure both power through the device and power reflected from the device, ratio'ed with the monitored incident power level.

Typically, two channels display insertion loss and return loss simultaneously. See the discussions for two channel insertion loss and two channel return loss measurements to define the channels and path cal the sensors.

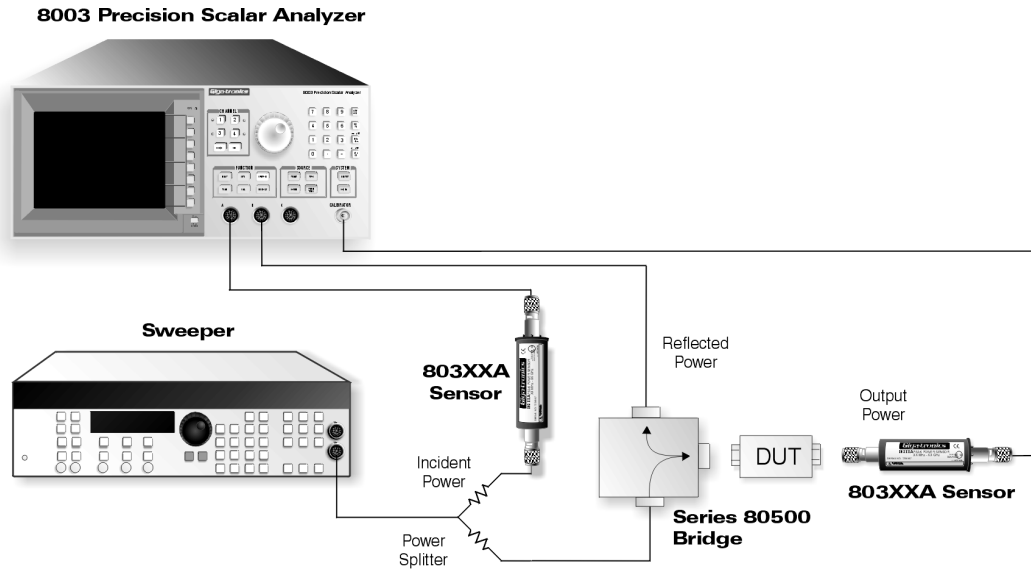

Figure 2-36: Three Sensor Configuration Block Diagram

2.9.6 Trace Memory

Trace memory is a powerful tool to normalize the displayed trace with either a golden standard or a particular reference device. In almost every case, a standard path cal could perform the same function. But trace memory can serve an additionally useful function.

Suppose you want to compare several components to a 'golden standard' component. After performing a path cal, you would measure the golden standard to find its characteristics (see Figure 2-37 for an example of golden standard measurement results).

Ideally, you would then like a way of memorizing this trace and subtracting it from subsequent traces on your other DUTs so that you could see how much variation the other DUTs had from the standard. That is exactly what trace memory allows you to do. To memorize the golden standard trace, press **[DEFINE]** then press the **[MEAS]** softkey. The analyzer stores up to 10 traces; you must first tell it which of the 10 memory registers you want the trace stored in. You do this by pressing the **[TRACE-TRACE N]** softkey followed by a number from 0 to 9, followed by the **[GHz/dB]** units key. To actually perform the subtraction of a DUT-Golden standard, press **[MEAS-TRACE N]** followed by the number of the trace to be subtracted (0 to 9), followed by the **[GHz/dB]** units key. The trace should now indicate differences between the DUT and the golden standard. To return to normal trace display, press the **[MEAS]** softkey.

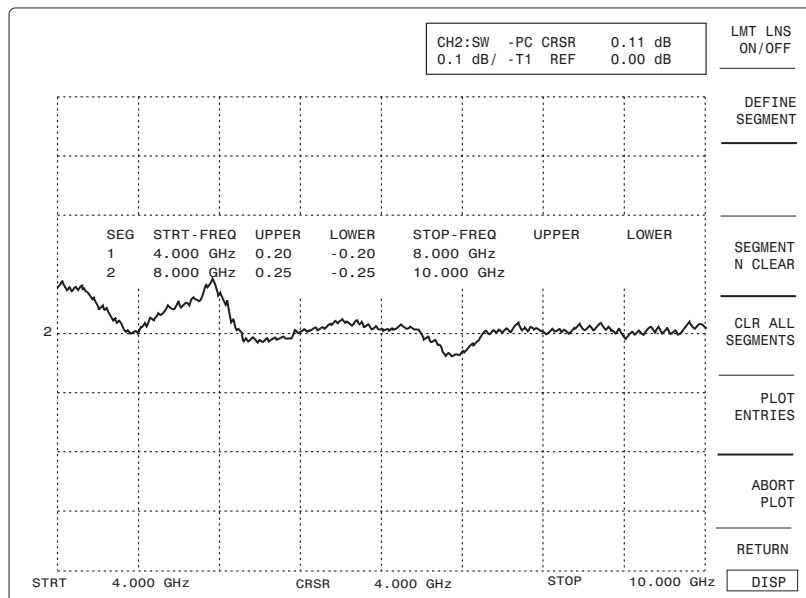

Figure 2-37: “Golden Standard” Precision 20 dB Attenuator Measurement Using 20 dB Attenuator Reference

The advantage of using trace memory over doing a path cal through the golden standard is that trace memory preserves the original path calibration. If you want to measure a different golden standard, or if you wanted to save several reference traces, you could make all the measurements using the same correct original path calibration.

2.10 Scaling the Display

One very common operation in a scalar analyzer is scaling the vertical axis. Scaling allows you to optimally position a channel trace on the screen, whether it is to see the device's gross characteristics (such as filter skirts or amplifier out-of-band rolloff), or the fine characteristics (such as ripple in a filter or amplifier's pass band), or to zoom in at a certain level to see how close a device makes or misses its specification limits.

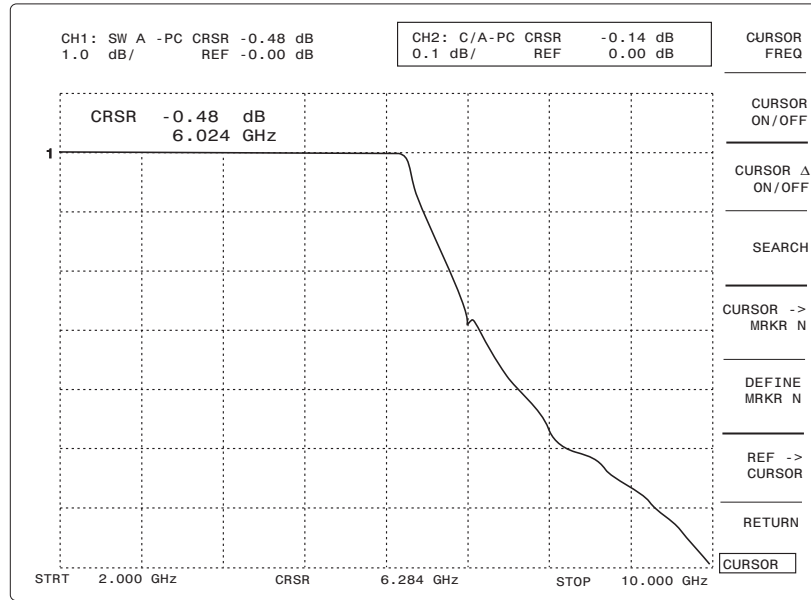

Figure 2-38: Device Gross Characteristics (Filter Skirt) Display

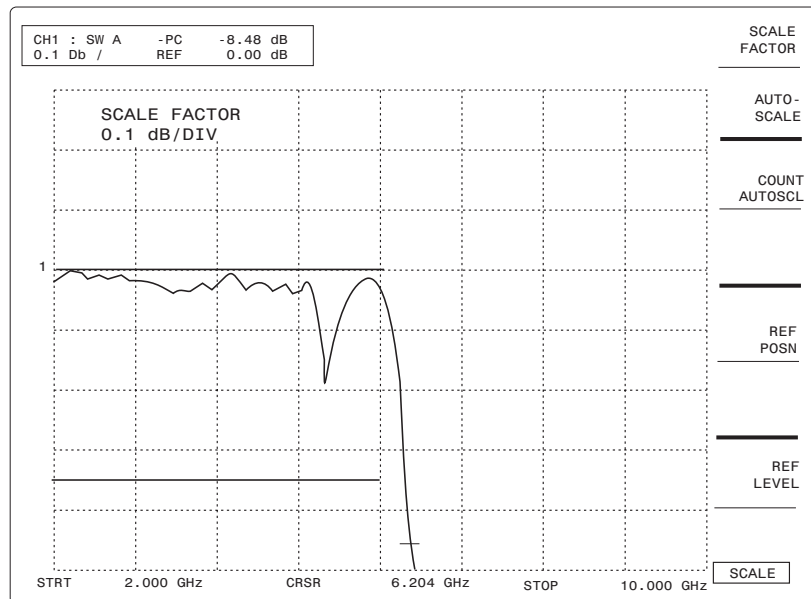

Figure 2-39: Device Fine Characteristics (Filter Pass Band) Display

All of the scaling functions of the analyzer can be found under the **[SCALE]** key. Each channel can be scaled independently, so the proper channel button must be pressed to make it the active entry channel before scaling. To scale a channel, press **[SCALE]** to bring up the scaling softkey menu on the display. The displayed trace vertical characteristics are dependent on three settings - the SCALE factor, the REFERENCE POSition, and the REFERENCE LEVEL.

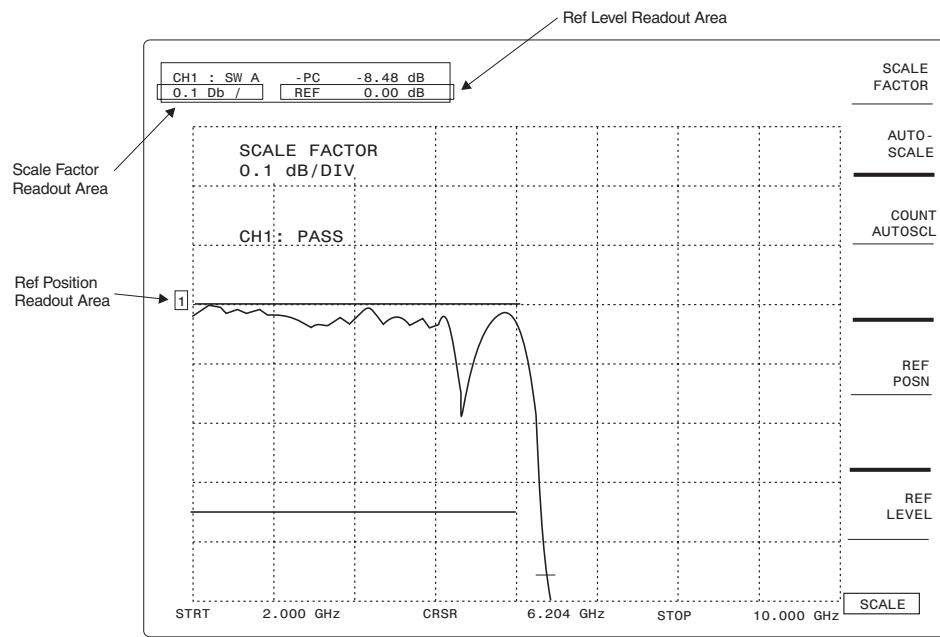

Figure 2-40: SCALE Display & Softkey Menu Typical Display

The easiest way to scale a trace is with the **[AUTO SCALE]** softkey. When you press this key, the analyzer will automatically scale the trace so that it fills the screen and is centered vertically. When autoscaling, the analyzer only changes the SCALE factor and REF LEVEL. Their new values can be read from the status section for the active channel.

Sometimes you will want to manually change the vertical characteristics of the display. To do this, you will use the **[SCALE FACTOR]**, **[REF LEVEL]** and **[REF POS]** softkeys.

The **[SCALE FACTOR]** softkey allows you to change the scale factor per division (in dB/division) with either the spin knob or the number pad. The scale factor setting is displayed in the lower left area of the status section for each channel.

The **[REF LEVEL]** softkey allows you to specify the level for the reference line. The reference line is the level on the screen which remains fixed during scaling. In other words, all points on the trace are scaled from that fixed level. The REF LEVEL value can be changed by either the spin knob or a number pad entry. This value is displayed in the lower right area of the status section for each channel.

The **[REF POS]** softkey allows you to change the graticule position on the screen of the reference line. The REF POS can only be changed by the spin knob, not by the number pad. The graticule position of the reference line is indicated by a small number on the left hand side of the grid corresponding to the channel number.

2.10.1 Hints on Simplified Scaling

The proper choice of REF POSition for the reference line can greatly simplify scaling. For device characteristics that only vary in one direction (for example, the gross characteristics of a filter, or almost any return loss trace), a convenient choice of the REF POS might be the top graticule line. Then, choose the REF LEVEL to be the maximum level of the trace. Now, when the trace is scaled, the zero return loss point or filter pass band will always remain on the screen, and the trace can always be conveniently scaled to fill the screen.

When measuring a device's characteristics that vary around a fixed level (pass band ripple, attenuation or gain vs. frequency, etc.), it may be best to choose the middle graticule line for the reference line's REF POSition. Then choose the REF LEVEL to be the average level of the device characteristic. This allows as much of the trace as possible to remain on the screen while scaling.

2.10.2 Using the Cursor to Set the Reference Level

Sometimes it is very convenient to indicate the desired reference level with the cursor. For example, you may want to examine the fine detail around a local maximum point you have previously identified with the cursor.

Make sure you have activated the cursor by pressing the **[CURSOR]** key. Now press **[SCALE]** to get back to the SCALE softkey menu. Use the spin knob to set the cursor at the desired level. Press the **[REF LEVEL]** softkey to bring up the REF LEVEL softkey menu. Now, press the **[REF-CURSOR]** softkey. The REFERENCE LEVEL will automatically be set to the cursor level.

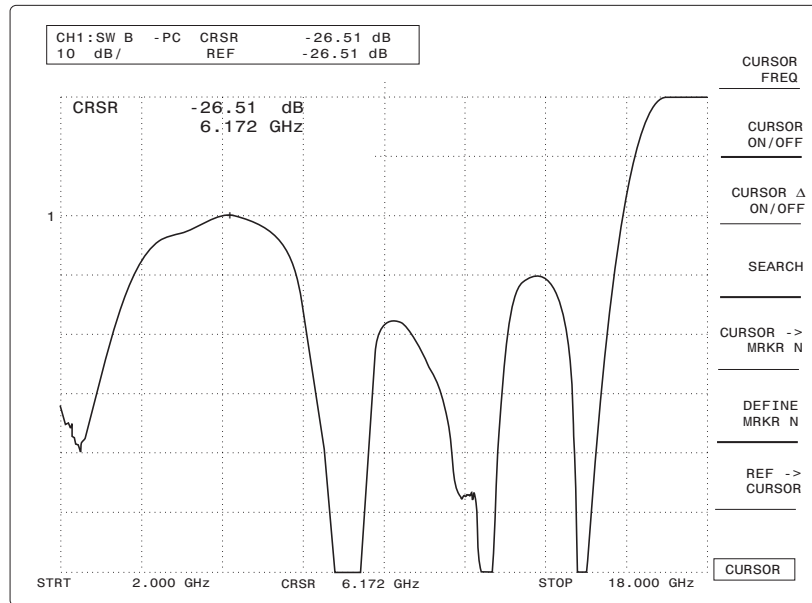

Figure 2-41: REF → CURSOR Function puts Local Maximum Reference Point at the Reference Point for Easy Scale Factor Expansion

2.11 Cursors & Markers

Cursors and markers provide a very convenient way to read numeric values right off the trace. The 8003 Precision Scalar Analyzer can display up to one cursor, one delta-cursor, and ten markers simultaneously on all four channels).

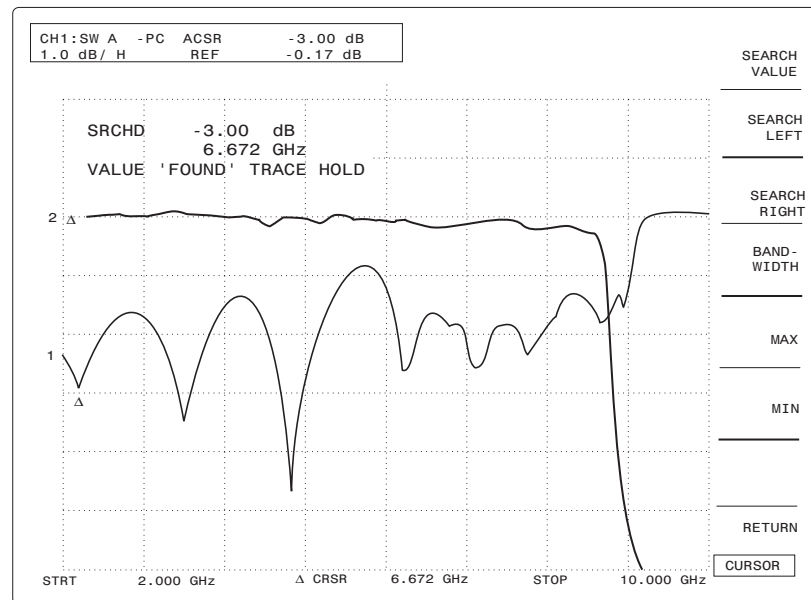

Figure 2-42: Typical Measurement (Cursors, Delta Cursors & Markers)

2.11.1 Search Functions Using the Cursor

The cursor indicates power and frequency at any point on the trace. It is activated when the **[CURSOR]** key is pressed, and can be controlled by the spin knob or by entry of a frequency on the numeric keypad.

The cursor search functions automate commonly used cursor operations such as min/max searches and -3 dB and bandwidth searches.

2.11.2 Min & Max Search

To search for the maximum point on a trace, press **[CURSOR]** followed by the **[SEARCH]** softkey. Press **[MAX]** to find the maximum point on a trace. The power/insertion loss/return loss at the maximum point is read next to the label **CRSR** in the active channel's summary area. The frequency at the maximum point is read at the bottom center of the screen.

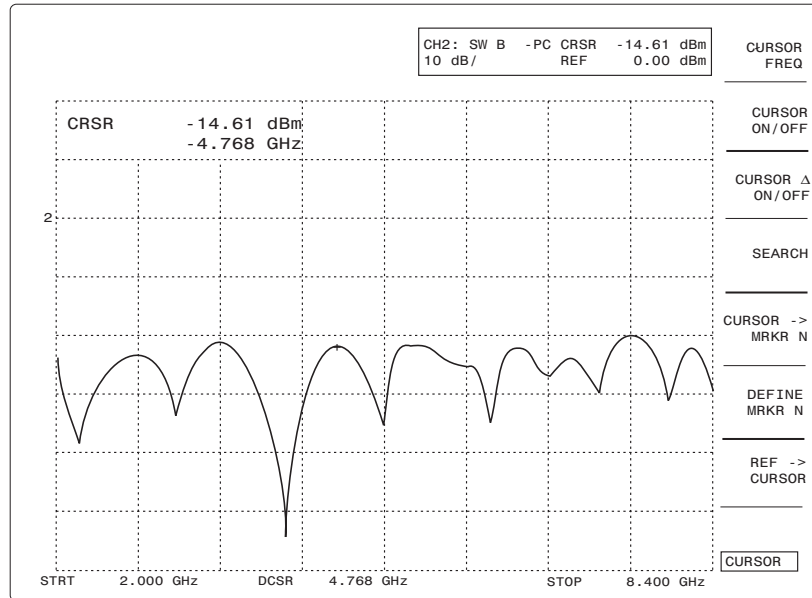

Figure 2-43: MAX Search Finds Minimum Return Loss of a Filter (Passband)

Alternately, you can press the **[CURSOR]** key again to reactivate the power/frequency readout in the active entry area. Pressing the **[MIN]** softkey finds the minimum point on a trace. MAX and MIN searches are often used as checks of a device against specification limits.

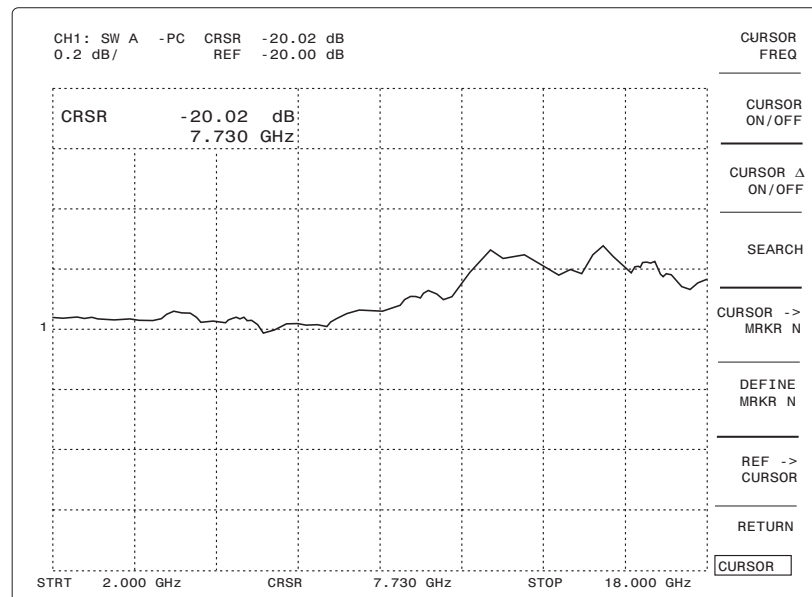

Figure 2-44: MIN Search Finds Max. Insertion Loss Point (20 dB Fixed Attenuator)

2.11.3 Searches on Frequency Selective Devices

One of the most common searches on frequency selective devices is the **-3 dB point**. This is easily done on the 8003 Analyzer by pressing **[CURSOR]** followed by the **[SEARCH]** softkey.

Note the Cursor position in relation to the target -3 dB point on the trace. Press **[SEARCH LEFT]** to search to the left of the cursor for the -3 dB point. Press **[SEARCH RIGHT]** to search to the right of the cursor for the -3 dB point. If the search is successful, the frequency and relative power level are shown in the active entry area. The active entry area on the screen shows that the default search value is -3 dB.

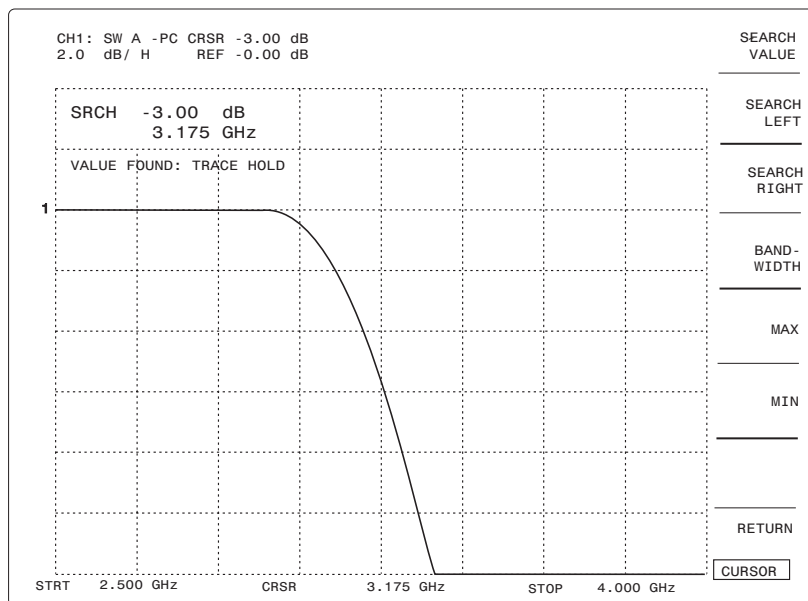

Figure 2-45: -3 dB Point (Low Pass Filter) at 3.175 GHz

You can change this to any negative or positive value by entering the desired value on the numeric keypad and pressing **[GHz/dB]**. For example, Figure 2-46 shows the -30 dB point on a high pass filter (sometimes used to determine filter cutoff).

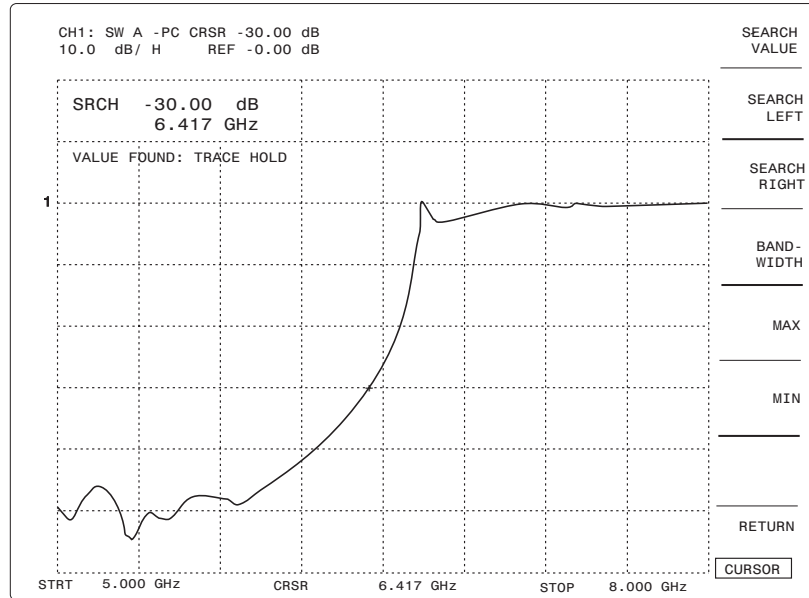

Figure 2-46: -30 dB Point (High Pass Filter)

The SEARCH LEFT and SEARCH RIGHT functions scan in the appropriate direction from the current position of the cursor to look for the level that is equal to the search value (relative to the 0 dB/dBm value). This is because many users prefer to specify devices from the 0 dB insertion level. Sometimes, this scheme may lead to unexpected results. For example, if the device under test is a filter with a minimum of 6 dB of insertion loss in the pass band, the search functions will never find the -3 dB point. To correct this situation, first find the Maximum point in the pass band using the [SEARCH] and [MAX] softkeys. Press **[CURSOR]** to return to the top level softkey menu and press the [DCURSOR ON/OFF] softkey. The new reference level will now be the maximum point on the trace and the search function will operate as expected.

2.11.4 Bandwidth Searches

The 8003 Analyzer can also find the bandwidth of frequency selective devices. Press **[CURSOR]** followed by the **[SEARCH]** softkey. Then press the **[BANDWIDTH]** softkey. The analyzer will automatically find the maximum point in the pass band of the device, then find the -3 dB points on the right and left of the maximum, and calculate the bandwidth.

Once the **[BANDWIDTH]** softkey is pressed, the search level can be changed by simply entering a new value on the numeric entry keypad and pressing **[GHz/dB]**.

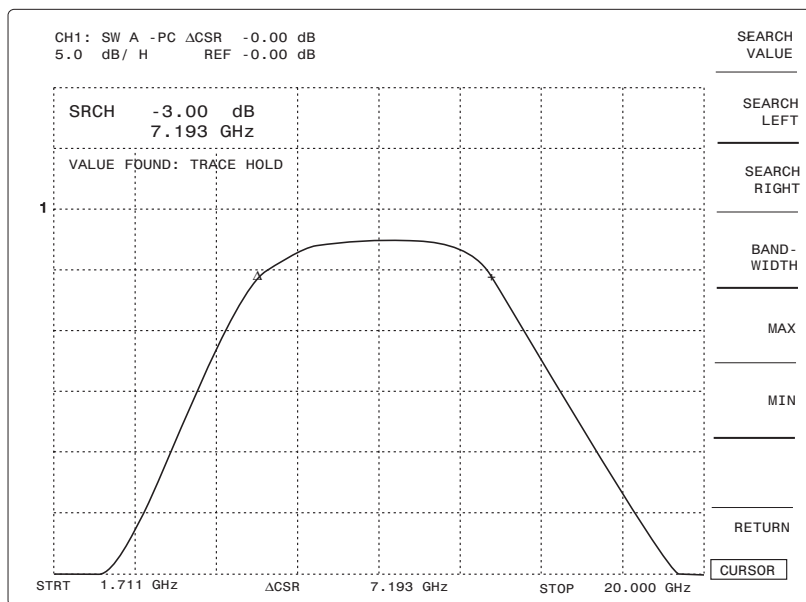

Figure 2-47: Automatic Bandwidth Movement (Very Narrow Bandpass Filter)

2.11.5 Cursor Delta (Δ) Functions

The 8003 Analyzer can make relative level and frequency measurements using the Cursor Delta function. To make a relative measurement, first place the Cursor at the desired reference point. Then press the [CURSOR Δ ON/OFF] softkey to toggle the Cursor Delta function on (ON should be in light blue). A small triangle (Δ) appears right on top of the Cursor '+' symbol. This is the cursor delta marker. The active entry area shows 0 dB relative level and 0 kHz relative frequency. This information is repeated in the channel summary area for the active channel, and in the cursor frequency area at the bottom of the screen.

Now use the spin knob to move the cursor away from the cursor delta marker and notice that the relative level and frequency are indicated in the active entry area. You can also use the numeric entry keypad to enter an exact frequency offset from the cursor delta marker. In Figure 2-48, the cursor delta function finds the next worst return loss point for this device.

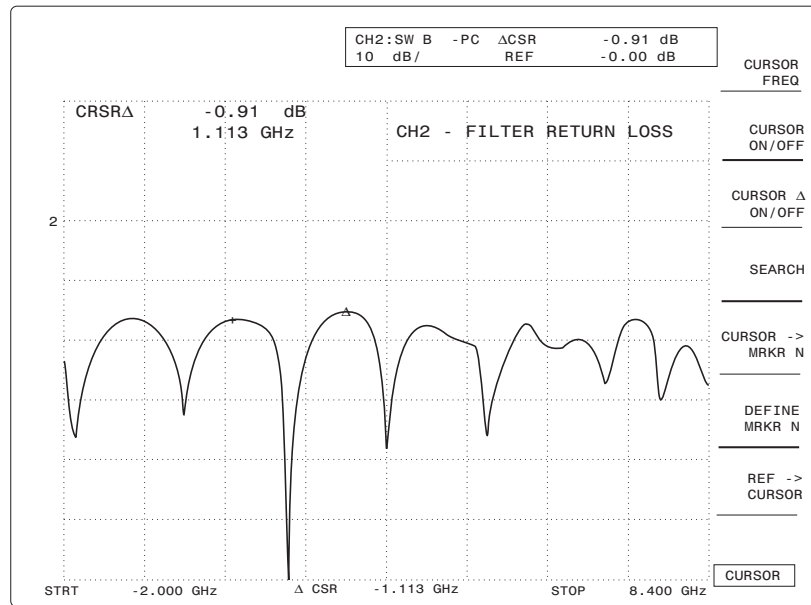

Figure 2-48: Cursor Delta Indicates Relative Level & Frequency (Next Worst Return Loss Point)

2.11.6 Cursors on Multiple Channels

Whenever cursors are used on multiple channels, they will always be tied to the same frequency but will show the appropriate amplitude on each channel. This is particularly useful when the cursor finds a feature of interest on one channel. Then, the corresponding amplitude can be read from another channel.

An example of this is a 1 dB compression measurement on an amplifier (see Figure 2-49). Suppose channel 1 is set to measure gain vs. input power, and channel 2 is set to monitor the output power of the amplifier. The cursor SEARCH functions find the point where gain decreases by exactly 1 dB on channel 1. The corresponding output level on channel 2 is the 1 dB compression level of the amplifier.

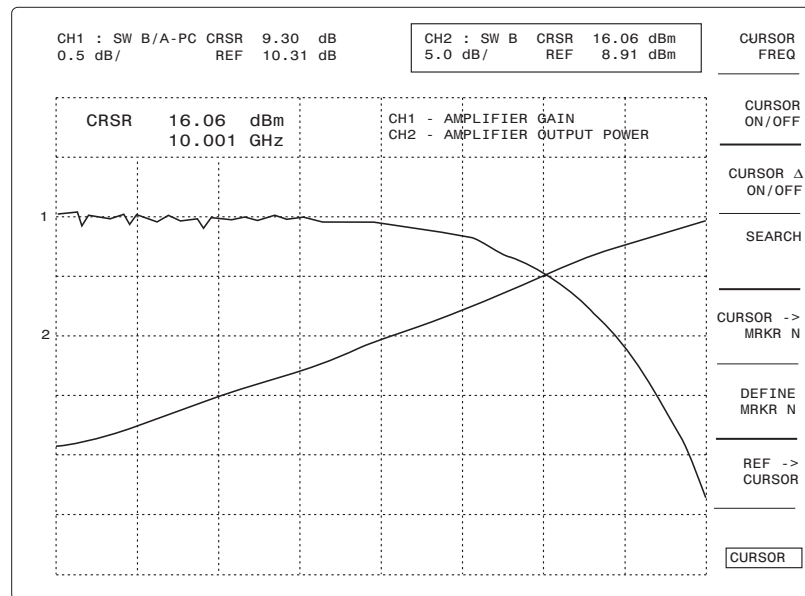

Figure 2-49: Cursors (Each Channel) Tied to Same Frequency Help Finding the 1 dB Compression Point on an Amplifier

2.11.7 Markers

Markers are useful to keep track of key points on a trace. The 8003 analyzer supports up to 10 internally generated markers. Markers are indicated by small circles on the trace.

Markers, like cursors, have many uses. One common use is to mark specific points of importance when tuning devices. For instance, filters must be tuned to an exact cutoff frequency. A marker indicates this cutoff frequency. The user then tunes for the proper amplitude at the marked frequency.

To place a marker on the trace, first move the Cursor to the desired marker location. Then press **[CURSOR]** and the **[DEFINE MRKR N]** softkey. Enter a number from 0 to 9 on the numeric entry keypad and press the **[GHz/dB]** units key. A small marker circle will appear at the cursor location (Figure 2-50). The cursor can then be moved to set up another marker. Markers can be individually turned on and off using the **[MRKR N ON]** and **[MRKR N OFF]** softkeys.

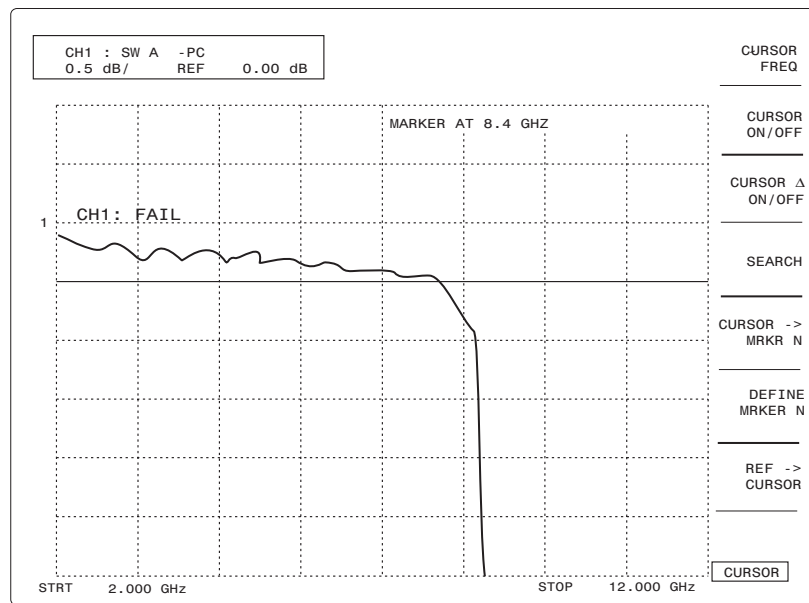

Figure 2-50: Filter Passband (Tuned Until Amplitude is -0.5 dB at the Marker)

The analyzer does not support sweeper-generated z-axis (or intensity) markers. It does, however, support sweeper-generated amplitude blips since these are amplitude spikes that actually appear on the output signal. Sweeper generated markers are often crystal-generated to improve the frequency accuracy of the trace. The frequency accuracy of the internally generated markers on the 8003 analyzer is generally limited by the accuracy of the sweeper's sweep ramp.

2.12 Power Measurements

One of the unique capabilities of the 8003 Precision Scalar Analyzer is to accurately measure microwave power. The analyzer is designed to always make as accurate power measurements as possible, but squeezing the last bit of performance from the analyzer requires attention to a few simple guidelines discussed later in section 2.14.

Accurate 8003 Analyzer power measurements always begin with the sensor calibration. Sensors should be calibrated at least once daily, preferably after a 5-minute warmup period. See Section 2.8.1 for calibration procedures.

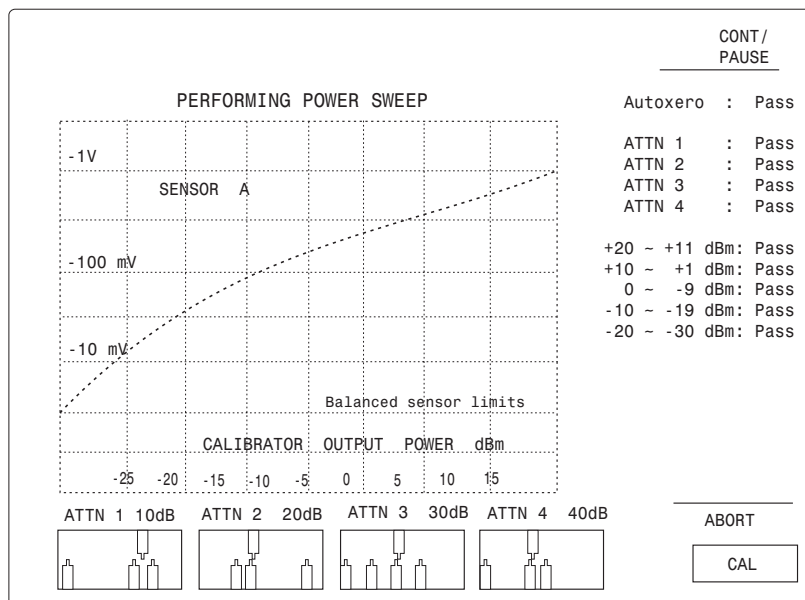

Figure 2-51: Sensor Calibration Screen

The 8003 Analyzer is capable of making fully corrected power measurements during a sweep. It does this by applying Cal Factors to each measurement point in the sweep. The sensor's Cal Factor is a correction for its frequency response. Cal Factors are precisely measured (typically at every 1 GHz) by the manufacturer or your Cal Lab, and are traceable to the National Institute of Standards Technology (NIST). All 803XXA series sensors used with the 8003 Analyzer have a table of Cal Factors stored in an EEPROM in the sensor. You can examine each sensor's Cal Factor table by pressing **[CONFIG]** followed by the **[SERVICE]** softkey. Then press **[SENSOR EEPROM]** followed by **[SENSR X EEPROM]**, where X is the sensor letter (A, B, or C). You will see a table similar to the one in Figure 2-52, giving identification information for the sensor.

8003 Precision Scalar Analyzer

PAGE 1 SENSOR C IDENTIFICATION		PAGE UP
SENSOR TYPE: TYPE N BALANCED		
SENSOR SERIAL NUMBER.....	01811240	SET TIME
LOWER FREQUENCY LIMIT (GHz).....	0.010	
UPPER FREQUENCY LIMIT (GHz).....	18.000	
VIDEO RESISTANCE RO+ (K-Ohms).....	2.660	
VIDEO RESISTANCE RO- (K-Ohms).....	2.710	
FREQUENCY RESPONSE START FREQ (GHz).....	2.000	CAL LOC
FREQUENCY RESPONSE STEP FREQ (GHz).....	1.000	
NUMBER OF ITEMS IN FREQ RESPONSE TABLE....	17	LAST PAGE
NUMBER OF SPECIAL FREQUENCY RESPONSE.....	1	
RETURN LOSS START FREQUENCY (GHz).....	0.000	PROGRAM EEPROM
RETURN LOSS STEP FREQUENCY (GHz).....	0.000	
NUMBER OF ITEMS IN RETURN LOSS TABLE.....	0	ENABLE INPUT
NUMBER OF SPECIAL RETURN LOSS.....	0	
CAL LOCATION: GIGA-TRONICS FACTORY		
CAL DATE: MONDAY 25 JUN 2001 16:30:06		ABORT
DATA INPUT: _		CONFIG

Figure 2-52: Sensor ID Table

Press [PAGE UP] to see the sensor Cal Factor table. You may need to press [PAGE UP] again or [PAGE DOWN] to see all of the table.

PAGE 2 FREQ RESPONSE TABLE (17 POINTS)			PAGE UP
DATA POINT	FREQUENCY (GHz)	CAL FACTOR (dB)	
1	2.000	-0.11	
2	3.000	-0.11	PAGE DOWN
3	4.000	-0.13	
4	5.000	-0.12	
5	6.000	-0.16	
6	7.000	-0.16	FIRST PAGE
7	8.000	-0.14	
8	9.000	-0.19	
9	10.000	-0.23	LAST PAGE
10	11.000	-0.19	
11	12.000	-0.25	
12	13.000	-0.38	
13	14.000	-0.43	ENABLE INPUT
14	15.000	-0.49	
15	16.000	-0.55	
DATA INPUT: _			CONFIG

Figure 2-53: Sensor CAL Factor Table

To exit back to the measurement mode, first press [FIRST PAGE] followed by [ABORT] and [ABORT PROGRAM]. Then press [RETURN] twice. You will now be back in the measurement mode.

The [ABSPWR/PATHCAL] softkey controls whether the analyzer makes a complete ABSolute PoWeR measurement (including Cal Factor correction), or ratio's the measurement with a previously stored PATH CALibration. If it ratio's with a PATH CALibration, the analyzer will not apply Cal Factor corrections since the measurement is already a ratio. This characteristic allows you to see the Cal Factor correction applied to a sweep. Figure 2-54 shows two traces made with the same sensor. The channel 1 trace shows an ABSolute PoWeR measurement with Cal Factor correction. The channel 2 trace shows exactly the same measurement without Cal Factor correction. As you can see, with Cal Factor corrections, the analyzer correctly shows the true flatness of the sweeper.

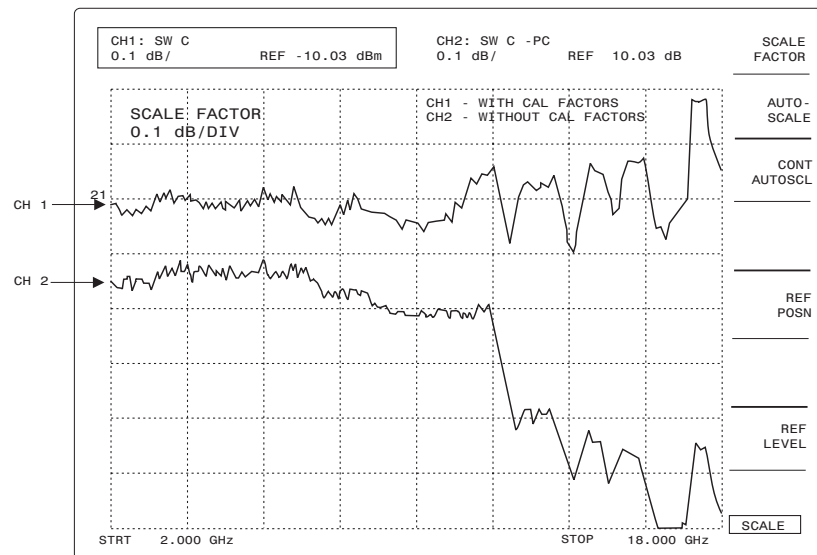

Figure 2-54: 8003 Swept Power Measurements with CAL Factor Correction

To set up the analyzer to make Absolute Power measurements on a channel, press **[MEAS]**. Toggle the [ABSPWR/PATHCAL] softkey until [ABSPWR/] is in light blue and [PATHCAL] is in dim, dark blue. All measurements will now be fully corrected with Cal Factor corrections, and will be displayed in units of dBm.

To set up the analyzer to ratio with a path calibration, press **[MEAS]** and toggle the [ABSPWR/PATHCAL] softkey until [PATHCAL] is in light blue. Now the analyzer will ratio with the stored path calibration data, but will not use Cal Factor corrections. All measurements will be relative to the stored path calibration data and displayed in dB.



NOTE: In either of the above cases, the cursor reads absolute power levels or power ratios at the selected frequency.

2.12.1 CW Power Measurements

The analyzer also supports a CW measurement mode that very closely resembles using a 4-channel CW power meter. All four channels can be toggled between swept and CW measurement modes using the [ALL SWEPT] and [ALL CW] softkeys under the [MEAS] key. To change modes, press [MEAS] followed by the [ALL CW] softkey. You should see a screen similar to Figure 2-55.

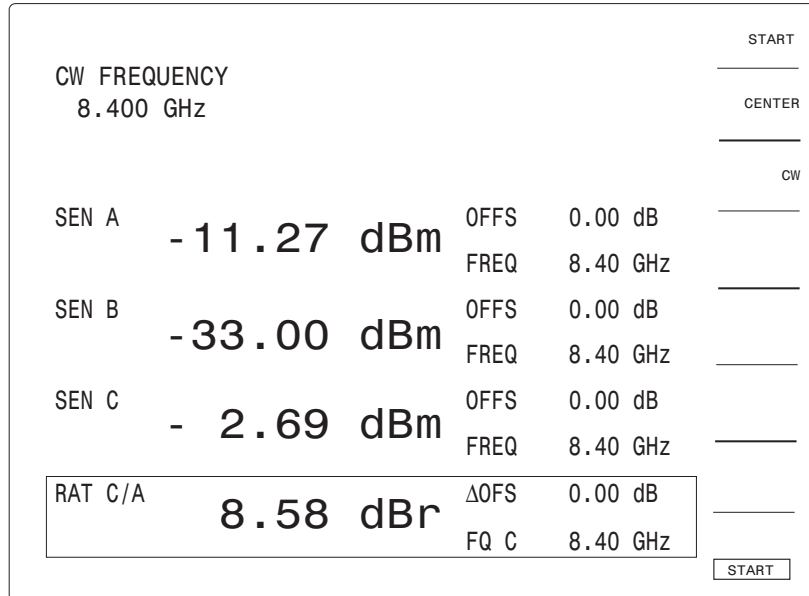

Figure 2-55: CW Readings (All 3 Sensor Inputs Plus Ratio)

When the [ALL CW] softkey is pressed, all channels that are ON are put into CW reading mode. The source is also put into CW mode using the CW frequency assigned using the source control key. If this is the first time you are using CW mode, change the CW frequency of the source to your desired frequency by first pressing [START] followed by the [CW] softkey. Enter the frequency on the numeric entry keypad and press the [GHz/dB] units key.

The CW measurement mode is more than a large readout display. The most significant difference is that the sensor input signal is actually filtered with a much narrower bandwidth to remove noise. In swept mode, the sensor input signals use a wide bandwidth for responsiveness to swept inputs.

2.12.2 Mixed Mode Measurements

The 8003 Analyzer uses a mixture of Swept and CW measurement modes. For example, you may want to sweep a mixer's RF port and measure its RF and IF responses in swept mode. But you might also want to monitor the fixed LO power in CW mode. As a special case, each channel can be individually configured to swept or CW measurement modes. To do this, press [DEFINE] to define a channel as swept or CW. Toggle the [CW/SWEPT] softkey until the channel is in the desired mode. The 8003 also has GRAPH or READOUT modes. The GRAPH mode is the familiar swept screen with traces. The READOUT mode is the one used for the ALL CW display. To change display modes, press [DISPLAY] and toggle the [GRAPH/READOUT] softkey until the analyzer is in the desired display mode.

The [CW/SWEPT] softkey in the DEFINE menu, and the [GRAPH/READOUT] softkey in the DISPLAY menu give you complete flexibility in configuring the analyzer measurement modes and display. The [ALL SWEPT] and [ALL CW] softkeys in the MEAS menu combine the functions to make switching between modes much faster and simpler.

NOTE: A Power Sweep Measurement capability is also available with the 8003 instrument. This feature is described in the Power Sweep Measurements Section 2.10.

2.12.3 Cal Factor Corrections in the CW Mode

When a channel is set to CW mode, the readings are corrected for Cal Factor. The 8003 Analyzer assumes that the signals measured are all at the same frequency that the source is set to.

Sometimes the sensors measure at a frequency different than that of the source. This may happen if there is frequency translation (mixers or up/downconverters) or frequency multiplication/division. In this case, you can manually enter the correct frequency by pressing [CONFIG] followed by the [SENSORS CW FREQ] softkey. You will see that the [FROM SOURCE] softkey is in light blue - indicating that the analyzer is currently using the CW frequency it commanded the source to go to. Press the [CW FREQ—] softkey and the appropriate [X CW FREQ] softkey where X is the sensor letter. Then enter your desired operating frequency on the numeric entry keypad followed by the [GHz/dB] units key (see Figure 2-56).

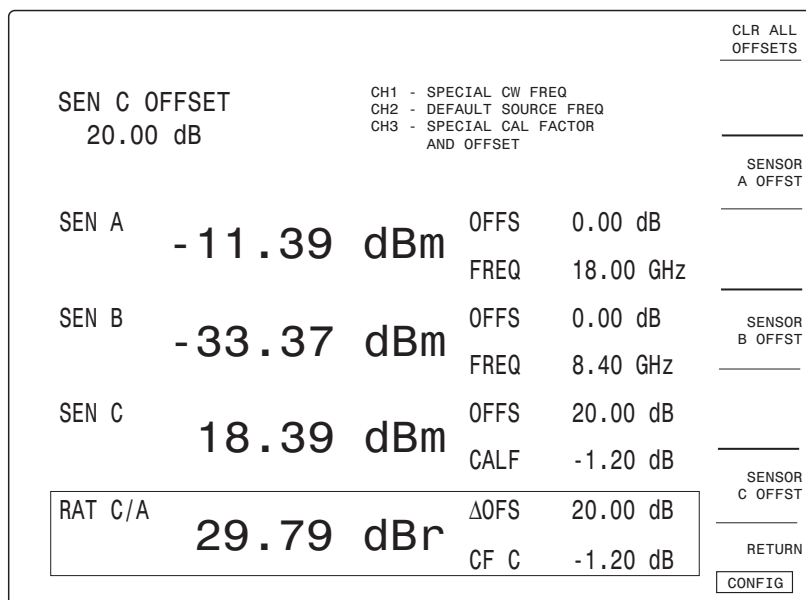

Figure 2-56: 3 Different Methods (CAL Factor Correction Plus Sensor Offsets)

Another way to make a Cal Factor correction is by direct entry of Cal Factor. This may be necessary if the sensor is user calibrated (perhaps with an adapter), and the user Cal Factors are not entered in the sensor EEPROM table. To make a direct Cal Factor correction, press the [CONFIG] key followed by the [SENSORS CW FREQ] softkey. Press the [CW CAL FACTOR] softkey, then the appropriate [X CAL FACTOR] softkey where X is the sensor letter.

8003 Precision Scalar Analyzer

To turn off Cal Factor correction completely, press **[CONFIG]** followed by the **[SENSORS CW FREQ]** softkey. Then press the **[CORRECTN OFF]** softkey. You will be given the choice to turn off selected sensor corrections, or all sensor corrections.

2.12.4 Sensor Offsets

In the CW mode, OFFSETS perform an analogous function to trace memory in swept mode. The offset is a fixed dB value that is added or subtracted from the reading (much in the same way that a memorized trace is subtracted from the measured trace). Offsets are useful for compensating for attenuators or amplifiers between the DUT and the power sensor.

To enter an offset, press **[CONFIG]** followed by the **[SENSORS OFFSET]** softkey. Press the appropriate **[SENSOR X OFFSET]** softkey where X is the sensor letter. Enter the offset value on the numeric entry keypad and press the GHz/dB units key. Use a positive offset value for attenuation between the DUT and sensor, and a negative offset value for gain.

2.12.5 Other CW Functions

When using the 8003 as a CW meter, some functions commonly found on CW meters come in handy. These are RELative measurements, MAX hold and MIN hold, and Averaging.

Averaging reduces the amount of noise on the signal. Most often, averaging is used when measuring very low level signals (below -40 dBm) to reduce the noise fluctuations of the reading. The number of averages chosen determines the amount of filtering. To add averaging to a CW Power measurement, first press the **[DISPLAY]** key, then select the AVG softkey. Either use the spin knob, or type in a desired averaging number from 1 to 256. (If you enter a number on the numeric entry keypad, remember to press the **[GHz/dB]** units key). Turn averaging on by pressing the **[AVG ON/OFF]** softkey.

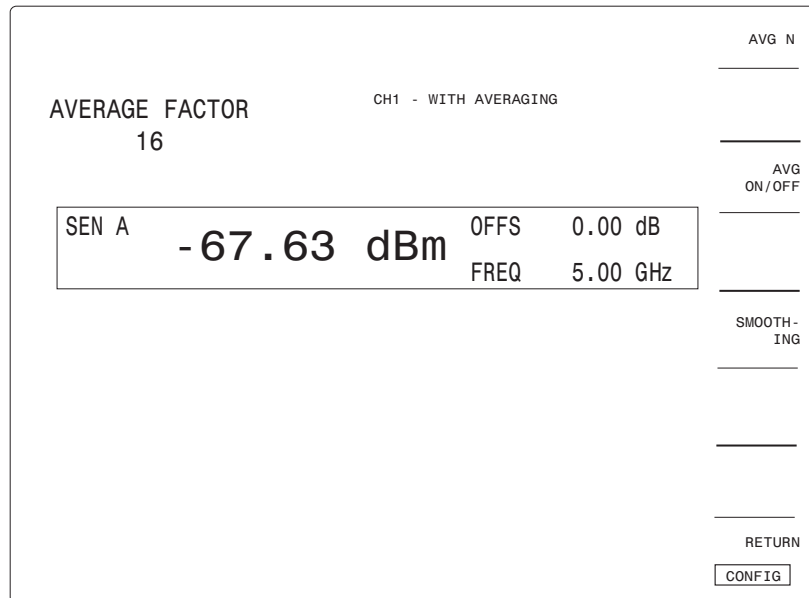

Figure 2-57: Averaging Used to Reduce Noise

MAX and MIN hold the maximum or minimum values recorded. This is often useful when adjusting a device or sweeping its response. To activate MAX or MIN hold, press **[MEAS]** and select the **[CW OPTION]** softkey. Then toggle either the **[MAXHOLDON/OFF]** or **[MINHOLDON/OFF]** softkey to activate the function. MAX or MIN hold will be in effect as long as the function is ON. If the **[CW OPTION]** softkey is in dim, dark blue, the channel on which you are trying to set MAX or MIN hold is

in the SWEPT mode. You must change it to the CW mode using the **[DEFINE]** key as described Section since MAX and MIN hold work only in the CW mode.

The RELative mode for CW measurements is similar to path cal for Swept measurements. Use the RELative mode to make CW measurements relative to a fixed reference level. To use the RELative function, first set your desired reference level using the CW Power reading as a guide. Then, to activate the RELative mode, press **[MEAS]** and select the [CW OPTION] softkey. Press the [RELON/OFF] softkey to read power relative to the reference level.

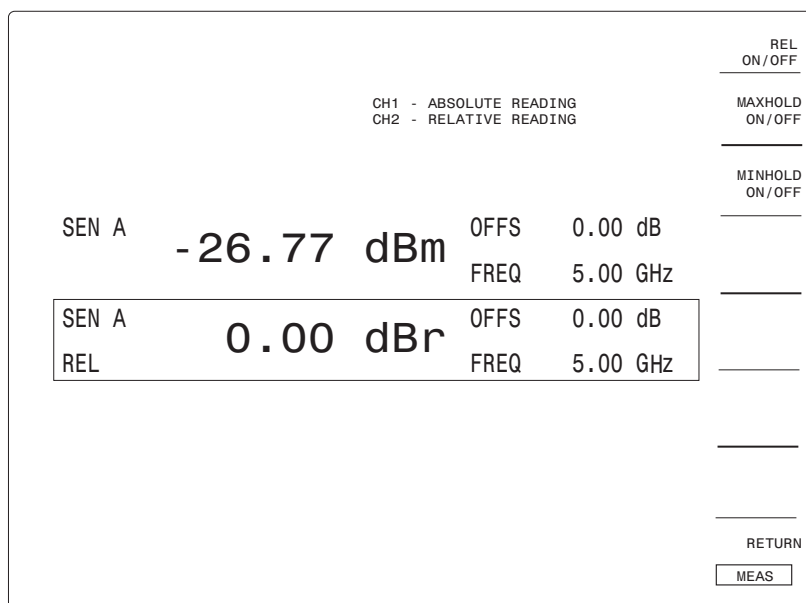

Figure 2-58: Reference Level & Corresponding Relative Reading

2.13 Accurate Range Measurements

Two of the key features of the 8003 Precision Scalar Analyzer are its broad 90 dB dynamic range and its exceptional -70 dBm sensitivity. Dynamic range and sensitivity are often key issues in component measurements. They determine the maximum insertion loss measurable for switches, attenuators, and filters. They determine how well input return loss can be measured on a high gain amplifier with low input levels. They also help when sweeper power is reduced through the use of splitters, switches, matching attenuators, or long lengths of cable.

It makes sense that wide dynamic range measurements start with getting the most power available from the source. But the art is in the low level measurement made at the other end of the device under test.

At very low signal levels, noise dominates the measurement. As a user, you will detect this noise in two forms - broadband thermal and circuit noise, and long term drift. Eliminating, or at least controlling this noise means attention to three factors - temperature stability, measurement mode, and averaging. If you are making measurements below -40 dBm, attention to these three factors will improve your measurement accuracy.

2.13.1 Temperature Stability

One of the best ways to control long term drift is to make sure that the analyzer and sensor have been connected and powered up long enough to stabilize in temperature. In general, if the instruments are at room temperature, you should allow at least 15 minutes after turn-on before attempting an accurate low level measurement. Temperature stability will continue to improve until 1 or 2 hours after turn-on.

When calibrating or connecting the DUT, try to minimize handling the sensors or bridges. Although temperature corrected and insulated, you may still see residual effects of a long hand grasp of the sensor - especially when measuring below -55 dBm.

2.13.2 Measurement Modes

Low level measurements can be made in three modes: the CW mode and two SWEPT modes (ac and dc detection). The mode chosen will impact the characteristics of any low level measurements. You may wish to choose different modes for different test requirements.

2.13.2.1 CW Mode

The 8003 Analyzer makes its best low level measurements in the CW mode. To get to CW mode, either press **[MEAS]** and select the **[ALL CW]** softkey, or press **[DEFINE]** and the **[CW/SWEPT]** softkey for your desired channel. Unlike the two swept modes, CW mode uses narrow bandwidth filtering to reduce noise much more efficiently. This means that the CW mode will give a stable reading much more quickly at low levels than either swept mode (of course, only at a single frequency). You can use this characteristic to either use less averaging (hence, less time) to get a stable reading, or more stable digits of resolution for the same measurement time.

To make the best low level measurements in the CW mode you should frequently re-zero the 8003 Analyzer. This removes the effect of drift from the measurement. Press **[CAL]** and select the **ZERO SENSOR** softkey. Then press the **[SENSORXZERO]** softkey, where X is the sensor letter (A, B, or C). If you are using a GPIB-supported sweeper, the 8003 Analyzer will automatically turn the RF off during zeroing. The sweeper must have less than -80 dBm of power output during RF off. Please be aware that many sweepers do not adequately suppress their signal during RF OFF if their output level is set above -20 dBm. If in doubt, disconnect the sensor, zero it, and reconnect it to the sweeper to check that the sweeper level is -70 dBm during RF OFF. Note that the closer you get to -70 dBm, the more apparent the drift will become, and the more frequently you will need to re-zero the Analyzer. Select the amount of averaging desired to get a stable reading. To use averaging, press **[DISPLAY]** and select the **AVG**

softkey. Turn averaging ON by pressing the [AVGON/OFF] softkey. Use the spin knob or numeric entry keypad to select the desired number of averages. To restart the averaging, turn the averaging OFF then ON again.

2.13.2.2 Swept Mode with AC Detection

If you are making swept measurements, ac detection mode will tend to give you better low level measurements than dc detection. The reason is that in ac detection mode, the sweeper output is chopped, and the analyzer constantly compares the RF ON level to the RF OFF level. Because the analyzer is always measuring the RF OFF level, the effects of drift are effectively canceled. The disadvantage of the swept-ac mode compared to the CW mode is that it takes much longer to average to a stable reading since only one average is made per sweep.

To use ac detection, first make sure that you are in the swept measurement mode. Press **[MEAS]** and select the [ALL SWEPT] softkey, or press **[DEFINE]** and select the [CW/SWEPT] softkey. Select ac detection by pressing **[CONFIG]** and selecting the [SENSORSAC/DC] softkey. Then, either press the [ALLAC] softkey or the [SENSRXAC/DC] softkey - where X is the desired sensor letter. This will put the analyzer in the ac detection mode. Make sure that the AC MOD OUTPUT BNC connector on the 8003 Analyzer's rear panel is connected to the sweeper PULSE MOD or AM input (see Section B.3.3.1 for the sweeper configuration instructions). If the sweeper is not GPIB supported, make sure that it's AM or PULSE modulation function is also enabled.

To make the best measurements in swept-ac detection mode, first zero the sensor using the method described in the CW mode in Section 2.13.2.1. Although frequent re-zeroing is not required since the ac detection is eliminating drift, an initial zero is required for accurate absolute power displays. Use a slow sweep (1 second) to ensure adequate resolution. Turn on averaging to reduce signal noise. To use averaging, first press **[DISPLAY]** and select the [AVG] softkey. Turn averaging on by pressing the [AVG ON/OFF] softkey. Then select the appropriate averaging number using the spin knob or numeric entry keypad. To restart the averaging, turn the averaging OFF then ON again.

2.13.2.3 Swept Mode with DC Detection

There may be occasions when swept low level measurements cannot be made in ac detection mode. An example may be testing an amplifier with an AGC control that cannot handle ac modulation. In these cases, the dc detection mode can be used. However, it may be difficult to adequately average out noise quickly enough to avoid the effects of drift. This will typically be the case for measurements below -60 dBm. To use dc detection, first make sure that the analyzer is in swept mode using the instructions for ac detection given previously. Then press **[CONFIG]** and select the [SENSORS AC/DC] softkey. Either press the [ALL DC] softkey, or toggle the desired [SENSRXAC/DC] softkey until DC is in light blue. Note that dc detection is the default mode of the analyzer.

To make the best swept low level measurements in dc detection mode you should first make sure that the analyzer has reached a very stable operating temperature to minimize the drift. Then, frequently re-zero the analyzer using the instructions given in the CW Mode in Section 2.13.2.1. Turn on averaging to reduce signal noise using the instructions given in the Swept Mode With AC Detection in Section 2.13.2.2.

2.14 8003 Power Sweep Measurements

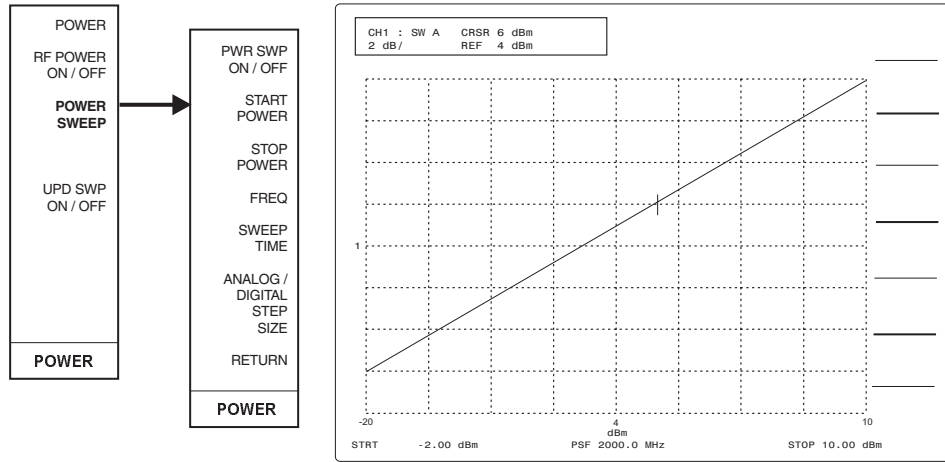

Menus used for Power Sweep Measurements

Display Produced by Power Sweep Measurements (Typical)

Figure 2-59: Menus & Typical Display (Power Sweep Measurements)

Besides Swept and CW measurements, the 8003 Analyzer supports a Power Sweep measurement mode. A linear power sweep of 20 dB or less is possible with 0.01 dB level resolution over a power range of 15 dBm to -120 dBm, depending on the source used (Giga-tronics 12000A, 7200, 7300 and HP8340, 8350B are presently supported). Digital power sweep is also possible with a 110 dB sweep range and a minimum step size of 0.01 dB. The Power Sweep Mode can be entered from the Swept Mode by pressing **[POWER]** followed by the **[POWER SWEEP]** softkey. Once this mode is accessed, the following variables can be set:

- Power Sweep ON/OFF
- Start Power Level
- Stop Power Level
- Frequency of Power Sweep
- Sweep Time
- Analog/Digital Power Sweep Mode
(Analog mode is the default. In the Digital mode, the Step Size default is 0.1 dB with a range of about 0.01 to ±110 dB. Digital power sweep dwell time is fixed at 10 msec).

A linear power sweep measurement can be made using the following keystrokes:

[POWER] **[POWER SWEEP]** **[PWR SWP ON/OFF]** (toggle ON)
[ANALOG] (toggle to ANALOG if necessary)
[START POWER] (enter the desired starting power level in dBm)
[STOP POWER] (enter the desired stopping power level in dBm)
[FREQ] (enter the desired frequency)
[SWEEP TIME] (enter the desired sweep time)

After the above parameters have been entered, a display similar to Figure 2-59 will appear, showing the selected settings and characteristics of the power sweep within the defined parameters.

A digital power sweep measurement can be made using the following keystrokes:

[POWER] [*POWER SWEEP*] [*PWRSWPON/OFF*] (toggle ON)
[*DIGITAL*] (toggle to *DIGITAL* if necessary)
[*STEP SIZE*] (enter the desired step size in dBm)
[*START POWER*] (enter the desired starting power level in dBm)
[*STOP POWER*] (enter the desired stopping power level in dBm)
[*FREQ*] (enter the desired frequency)

If any other measurement modes are accessed, it may be necessary to reenter the Power Sweep Mode as described above.

All of the usual measurements and corrections are possible (Ratio, Cal Factor, Averaging, Smoothing, Frequency Correction, etc.)

Since the dynamic range of Giga-tronics power sensors is from -70 to +47 dBm depending on the sensor type, the selected power range must be kept within these limits. It is up to you to make sure this criteria is met.

Remote Operation

3.1 Introduction

This chapter explains how to operate the 8003 Precision Scalar Analyzer from a remote location using a system controller in conjunction with necessary computer devices. The system operates over a General Purpose Interface Bus (GPIB) compliant with IEEE 488 interface standards.

3.2 IEEE Bus Interface

3.2.1 Connect the System Controller

Connect the GPIB port on your system controller to the 8003 with an IEEE 488 interface cable. Connect the interface cable to the GPIB/SYSTEM port on the 8003 rear panel. If you will be controlling the sweeper through the 8003 Analyzer, connect the sweeper GPIB interface cable to the GPIB/PRIVATE port. If you will be controlling the sweeper directly from the system controller, connect the sweeper GPIB interface cable to the GPIB/SYSTEM port (see Figure 3-1).

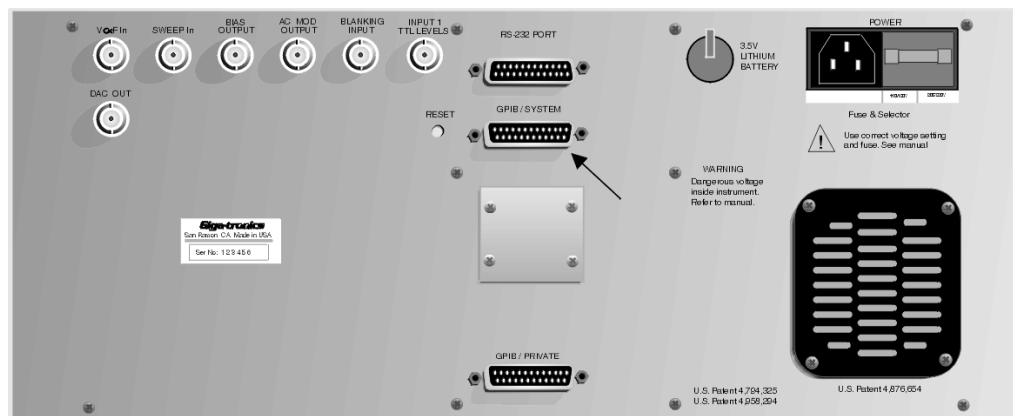

Figure 3-1: Location of GPIB/System Connection (Rear Panel)

3.2.2 Set the GPIB Address

The 8003 Analyzer has a default GPIB address of 4. If you need to change the address, press **[CONFIG]** on the front panel, then press the **[GPIB DEVICES]** softkey. You should see a message in the active entry area of the display that says ANALYZER ADDRESS 4 (or whatever the current address number is). Enter your new GPIB address on the numeric entry keypad and press the **[GHz dB]** units key.

8003 Precision Scalar Analyzer

3.2.2.1 Programming the 8003

The remainder of this chapter explains how to program the 8003 Analyzer and supported sweeper over the GPIB bus. The instructions assume that you are familiar with the front panel operation of the instrument and that you have properly configured the system.

The 8003 GPIB command set allows direct control of most front panel functions, including all of the functions found under the DEFINE, MEAS, DISPLAY, CURSOR, SCALE, CAL, MEMORY, START, POWER, SWEEP TIME, and PRESET softkeys (with the exception of the display setup functions found under the **DISPLAY** key). Some of the lesser used functions under the SERVICE softkey menu of the **CONFIG** key are not controlled via direct GPIB commands, but can be accessed through the keyboard emulation mode.

The GPIB command set allows extended capabilities of the analyzer beyond those accessible through the front panel. These include reading of swept measurement data, upload and download of trace memories, path cal and Cal Factor memories, three modes of high speed CW power measurements, and a Pass Through mode for direct communication with devices on the 8003 private bus.

The 8003 Analyzer uses a simple programming structure consisting of commands (called verbs) followed by command modifiers. Because the 8003 is driven by softkeys, these commands do not necessarily follow the same sequence as front panel key strokes. However, you will find that they do give a very logical access to the instrument's functions.

A simple sequence of commands is usually sufficient to set up the instrument and obtain data over the bus. The basic sequence of commands is:

1. Send a GPIB **device clear** to PRESET the analyzer to a known, fixed state.
2. Set up the analyzer measurement mode (SWEPT or CW) and configure its channels (single sensor, ratios, or differences).
3. Set up the sweeper parameters (frequencies, power levels).
4. Set up the analyzer's display mode and scaling (this step is optional).
5. If needed, Calibrate and Zero the sensors.
6. Take a reading of data.

This sequence of commands is illustrated in the programming example on the next four pages. The first two examples for CW and swept measurements are written in TBASIC for IBM-PC users. The second two examples are the identical programs written in HP-Basic for HP series 200 and 300 users.

Typical TBASIC Program for Swept Measurements

```

100 ! *****
110 ! 8003 Swept Measurement Demonstration program
120 ! TBasic version
130 ! Copyright 2001, Giga-tronics Power Measurements Division
140 ! *****
150 !
160 OPTION BASE 1! arrays start with index of 1
170 DIM Data array[512],Buffer$(5000)! allocate storage for swept data
180 !
190 POLL Status,Primary;4! Use serial poll to clear any existing srq s
200 WRITE GPIB CMD(Dc1)! Device Clear does a PRESET on the 8003
210 !
220 ! Set up Analyzer channel configuration first
230 !
240 PRINT @4:SWP 1,A;on;meas! channel 1 is in swept mode, sensor A,
250 !                               and reads in absolute units
260 PRINT @4:SWP 2,B;on;meas! channel 2 is in swept mode, sensor B,
270 !                               and reads in absolute units
280 PRINT @4:CHAN 3;off;CHAN 4;off! turn off channels 3 and 4
290 !
300 ! Now, set up the sweeper parameters
310 !
320 PRINT @4:SWPF;start 2000;stop 8000;level 10;swpt 500
330 ! Set start frequency 2GHz, stop frequency 8 GHz,
340 ! Output level +10 dBm, and sweep time 500 ms/sweep
350 PRINT @4:SWPF;level on! turn on RF output
360 SLEEP 8 ! put in appropriate wait time for sweeper to set up
370 !
380 ! These next lines set up display format but are not strictly
390 ! necessary for data collection over the bus
400 !
410 PRINT @4:GRAPH! graph display mode
420 PRINT @4:SWP 1;scale 1;ref pos 0;ref lev 10! scale channel 1
430 PRINT @4:SWP 2;scale 5;ref pos 0;ref lev 0! scale channel 2
440 !
450 ! Zero sensor A before taking a reading
460 !
470 ON SRQ GOTO Done zeroa! exit when zeroing done
480 PRINT @4:ZERO A;srq! Zero sensor A, pull srq when done
490 Loop1: GOTO Loop1! Wait until srq (or do other tasks)
500 Done zeroa: POLL Status,Primary;4! Clear srq with serial poll
560 OFF SRQ ! disable further srq s
570 !
580 ! Take a reading
590 !
600 SLEEP 4 ! put in time to make sure sweeper is settled
610 PRINT @4:OUTPUT 1;items 512! read 512 swept data points
620 INPUT @4 LINE Buffer$! Read data into string buffer
625 INPUT FROM Buffer$:Data array! convert to data array
630 PRINT Data array;
640 !
650 END

```

8003 Precision Scalar Analyzer

Typical TBASIC Program for Stepped CW Measurements

```
100 ! *****
110 ! 8003 CW Measurement Demonstration program
120 ! TBasic version
130 ! Copyright 2001, Giga-tronics Power Measurements Division
140 ! *****
150 !
160 OPTION BASE 0! arrays start with index of 0
170 DIM Buffer[19]! allocate storage for CW data
180 !
190 POLL Status,Primary;4! Use serial poll to clear any existing srq s
200 WRITE GPIB (MD(Dc1)! Device Clear does a PRESET on the 8003
210 !
220 ! Set up Analyzer channel configuration first
230 !
240 PRINT @4:POWER 1,A;avg 4;on! channel 1 is in swept mode,
250 !                               Sensor A, 4 averages
260 PRINT @4:CHAN 2;off;CHAN 3;off;CHAN 4;off
270 !
280 ! Now, set up the sweep parameters
290 !
300 PRINT @4:FIXED;freq 2000;level -15
310 ! Set CW frequency of 2 GHz, level at -15 dBm
320 PRINT @4:FIXED;level on! turn on RF output
330 SLEEP 8 ! put in appropriate wait time for sweeper to set up
340 !
350 ! This next line sets up display format but is not strictly
360 ! necessary for data collection over the bus
370 !
380 PRINT @4:READOUT! power meter display mode
390 !
400 ! Zero sensor A before taking a reading
410 !
420 ON SRQ GOTO Done zeroa ! exit when zeroing done
430 PRINT @4:ZERO A;srq! Zero sensor A, pull srq when done
440 Loop1: GOTO Loop1! Wait until srq (or do other tasks)
450 Done zeroa: POLL Status,Primary;4! Clear srq with serial poll
460 OFF SRQ ! disable further srq s
470 !
480 ! Take a reading
490 !
500 FOR Reading no = 0 TO 19! take 20 readings
510 PRINT @4:FIXED;freq ;2000+Reading no/19*(8000-2000)
520 !step sweeper in 20 even steps from 2 to 8 GHz
530 SLEEP 1 ! make sure sweeper is settled
540 PRINT @4:POWER 1,avg off! turn averaging off to restart
550 PRINT @4:POWER 1,avg on! then turn averaging on
560 PRINT @4:OUTPUT 1! ask for reading
570 INPUT @4:Buffer[Reading no]! put reading in data buffer
580 NEXT Reading no
590 PRINT Buffer;
600 !
610 END
```

Typical HP-Basic Program for Swept Measurements

```

100 ! *****
110 ! 8003 Swept Measurement Demonstration Program
120 ! HP300 Series Version
130 ! Copyright 2001, Giga-tronics Power Measurements Division
140 ! *****
150 !
160 OPTION BASE 1! arrays start with index of 1
170 DIM Data array(512)! allocate storage for swept data
180 !
190 Status=SPOLL(704)! use serial poll to clear any existing srq s
200 CLEAR 704! Device Clear does a PRESET on the 8003
210 !
220 ! Set up analyzer channel configuration first
230 !
240 OUTPUT 704;SWP 1;A;on;meas! channel 1 is in swept mode, sensor A
250 !                               and reads in absolute units
260 OUTPUT 704;SWP 2;B;on;meas! channel 2 is in swept mode, sensor B
270 !                               and reads in absolute units
280 OUTPUT 704;CHAN 3;off;CHAN 4;off! turn off channels 3 and 4
290 !
300 ! Now, set up the sweeper parameters
310 !
320 OUTPUT 704;SWPF;start 2000;stop 8000;level 10;swpt 500
330 ! Set start frequency 2 GHz, stop frequency 8 GHz,
340 ! output level +10 dBm, and sweep time 500 ms/sweep
350 OUTPUT 704;SWPF;level on! turn on RF output
360 WAIT 8! put in appropriate wait time for sweeper to set up
370 !
380 ! These next lines set up display format but are not strictly
390 ! necessary for data collection over the bus
400 !
410 OUTPUT 704;GRAPH                               ! graph display mode
420 OUTPUT 704;SWP 1;scale 1;ref pos 0;ref lev 10 ! scale channel 1
430 OUTPUT 704;SWP 2;scale 5;ref pos 0;ref lev 0 ! scale channel 2
440 !
450 ! Zero sensor A before taking a reading
460 !
470 ENABLE INTR 7;2! enable interrupts from instrument srq s
480 ON INTR 7 GOTO Done zeroa! exit when zeroing done
490 OUTPUT 704;ZERO A;srq! zero sensor A, pull srq when done
500 Loop1: GOTO Loop1! Wait until srq (or do other tasks)
510 Done zeroa: Status=SPOLL(704)! clear srq with serial poll
520 !
530 ! Take a reading
540 !
550 WAIT 4 ! put in time to make sure sweeper is settled
560 OUTPUT 704;OUTPUT 1;items 512 ! read 512 swept data points
570 ENTER 704;Data array(*)
580 PRINT Data array(*)
590 !
600 END

```

8003 Precision Scalar Analyzer

Typical HP-Basic Program for Stepped CW Measurements

```
100 ! *****
110 ! 8003 CW Measurement Demonstration Program
120 ! HP300 Series Version
130 ! Copyright 2001, Giga-tronics Power Measurements Division
140 ! *****
150 !
160 OPTION BASE 0! arrays in this example start with index of 0
170 DIM Buffer(19)! allocate storage for CW data
180 !
190 Status=SPOLL(704)! use serial poll to clear any existing srq s
200 CLEAR 704! Device Clear does a PRESET on the 8003
210 !
220 ! Set up analyzer channel configuration first
230 !
240 OUTPUT 704:POWER 1,A;avg 4;on! channel 1 is in CW mode, sensor A
250 !                               and has an averaging number of 4
260 OUTPUT 704:CHAN 2;off;CHAN 3;off;CHAN 4;off
270 !                               turn off channels 2, 3, and 4
280 !
290 ! Now, set up the sweeper parameters
300 !
310 OUTPUT 704:FIXED;freq 2000;level -15
320 ! Set CW frequency of 2 GHz and output level of -15 dBm
330 OUTPUT 704:FIXED;level on! turn on RF output
340 WAIT 8! put in appropriate wait time for sweeper to set up
350 !
360 ! This next line sets up the display format but is not strictly
370 ! necessary for data collection over the bus
380 !
390 OUTPUT 704:READOUT! make sure that the analyzer is in readout
400 !                               (large number display) mode
410 !
420 ! Zero sensor A before taking a reading
430 !
440 ENABLE INTR 7;2! enable interrupts from instrument srq s
450 ON INTR 7 GOTO Done zeroa! exit from current routine when zeroing
done
460 OUTPUT 704:ZERO A;srq! zero sensor A, pull srq when done
470 Loop1: GOTO Loop1! Wait until srq (or do other tasks)
480 Done zeroa: Status=SPOLL(704)! Clear srq with serial poll
490 !
500 ! Take a series of readings in CW mode
510 !
520 FOR Reading no=0 TO 19! take 20 readings
530 OUTPUT 704:FIXED;freq ;2000+Reading no/19*(8000-2000)
540 ! set sweeper cw frequency to evenly space readings from 2 to 8 GHz
550 WAIT 1! put in time to make sure sweeper and analyzer are settled
560 OUTPUT 704:POWER 1,avg off! restart averaging by first turning off
570 OUTPUT 704:POWER 1;avg on! then turn averaging on
580 OUTPUT 704:OUTPUT 1! ask for reading
590 ENTER 704;Buffer(Reading no)! put the reading in the data buffer
600 NEXT Reading no
610 PRINT Buffer(*)
620 !
630 END
```

3.3 Structured GPIB Language

The 8003 is a complex instrument with many features. The goal of providing a structured language environment is to make programming the 8003 easier. The advantage of using a structured language is that it provides a common structure for each command. This structure is easy to remember and makes the resulting programming command strings readable by others. This, in turn, helps make your programs more self documenting, thus aiding in maintaining them.

3.3.1 Common Structure

The language used in the 8003 command structures is in accordance with ANSI/IEEE Std. 488.2-1987, IEEE Standard Codes, Formats, Protocols, and Common Commands. Each structure defines a command, which addresses an 8003 feature or resource. The command is defined by a context setting VERB mnemonic. The general form for all commands is as follows:

VERB [*hs specifier*] [*ds sensor specifier*] [*us modifier*]...[*us modifier*]

Where **VERB** is a context setting mnemonic which is always required. For convenience, long and short forms for the same verb are sometimes available (for example, POWER and PWR).

The mnemonic inside the brackets is optional (see Section 3.3.3 for definition of each separator).

hs is a header separator

ds is a data separator

us is a unit separator

The ... notation indicates that a field may be repeated. In the general syntax format, it indicates that the modifier may be repeated.

The *specifier* can be either a channel or sensor specifier. The type of specifier is particular to the command.

A *channel specifier* is a mnemonic that defines the channel for which the command is to be applied. In the general syntax form shown above, this specifier is shown as optional. The type of command determines whether or not it is required. This specifier is for all channel-specific command VERBS. An example of a channel specific command would be a command that directed the 8003 to make a measurement on a given channel. An example of a non-channel specific command would be to direct the 8003 to use the graphic display mode or to turn off the private bus.

A *sensor specifier* is a mnemonic that defines a sensor or sensor pair for which the command is to be applied. This specifier is for all sensor-specific commands. An example would be a command that directs the 8003 to calibrate a sensor.

A *modifier* is a sub-structure to modify or augment the main context. This sub-structure also has a general format which is defined below. When several different versions of a modifier are given (such as OFFSET, OS, ATTN), any version can be used with the same results.

3.3.2 8003 GPIB Commands

Tables 3-2 and 3-3 lists the 8003 GPIB commands. The commands are duplicated on the separate laminated sheet furnished with this manual.

Giga-tronics 8003 GPIB Commands Cont.

Calibration Commands		Input/Output Commands	
CAL	A B ; srq C	INPUT ;	Trace n Pathcal A/B/C Calfactor A/B/C ENR n
THRU	A B ; srq C		
SHORT	A B ; srq C <linefeed> OPEN	OUTPUT ;	1 2 3 items 4 ; n Trace n curp Pathcal A/B/C srq Calfactor A/B/C limit ENR n
ZERO	A B ; srq C		
Instrument Configuration Commands			
GRAPH		RDTEMP	*IDN? (instrument identification)
DISABLE		ENABLE (private bus)	*ESR? (read external status register)
BIAS	1 2 , n 3 4	MEMORY ; store n recall n	KEYEM on off
		READOUT	
Sweeper Commands			
SWPF ;	start<?> n stop<?> n level<?> n off on swpt<?> n upd on-off	FIXED ;	freq<?> n level<?> n pff on opd on-off
		SWPS ;	cd<?> n span<?> n level<?> n off on swpt<?> n upd on-off
Printer Commands			
PRINT ;	ink paint laser	PLOT ;	all ;srq upl lowl lowr sp_trace sp_label sp_grid custom ;grid freq_lb summary scale title trace n logo

Figure 3-3: GPIB Commands (Back)

3.3.3 Command Execution

A command string is executed when an EOL signal is received (see Section 3.3.3.4). Until an EOL signal is received the 8003 will parse, check for operational errors and syntax errors and store but not execute the request as defined by a command string. Any number of context setting VERBS may appear in an input string. Each time a new VERB is parsed, a new context is established and all specifiers and modifiers to follow are interpreted for that VERB. The required syntax for each command must be followed to avoid generating syntax errors. The VERB structures may appear in any order within the program string.

3.3.3.1 *hs* Definition

The header separator (*hs*) mnemonic is defined as zero or more ASCII white space characters between a command header and accompanying data.

3.3.3.2 *ds* Definition

The data separator (*ds*) mnemonic is defined as zero or more ASCII white space characters followed by an ASCII comma followed by zero or more ASCII white space characters. It can be between any two items of data. Always see the syntax diagram for the specific command for the proper use of this separator.

3.3.3.3 *us* Definition

The unit separator (*us*) mnemonic is defined as zero or more ASCII white space characters followed by an ASCII semicolon followed by zero or more ASCII white space characters.

3.3.3.4 EOL Definition

The End Of Line separator (EOL) mnemonic is defined as zero or more ASCII white space characters followed by zero or one ASCII carriage return character followed by an ASCII line feed character. Alternatively, the IEEE 488 EOI line may be sent true with the last ASCII character of the last mnemonic. The command string is executed upon parsing of the EOL command.

3.3.3.5 Case Insensitivity

All of the command mnemonics can be sent in either upper or lowercase. Although the 8003 is insensitive to case, it is useful to program strings in a mix of upper and lowercase alphas. One suggestion is to construct VERB and sensor specifier mnemonics in uppercase and all other alpha mnemonics in lowercase alphas. The reason for this is to make the verbs more visible and hence more readable. Other programmers reading your ATE code will appreciate this and so will you when you are reviewing code months after you have written it. All of the examples in this chapter are presented in this fashion.

3.3.4 IEEE GPIB Interface Characteristics

AH1	Acceptor Handshake, complete capability
SH1	Source Handshake, complete capability
T6	Talker Function, complete capability (-TON)
TE0	Extended Talker Function, no capability
L4	Listener Function, Basic listener, unaddressed if MTA
LE0	Extended Listener Function, no capability
SR1	Service Request Function, complete capability
RL1	Remote Local Function, complete capability (LLO)
PP0	Parallel Poll Function, no capability
DC1	Device Clear Function, complete capability
DT1	Device Trigger Function, complete capability
C0	Controller Function, no capability

3.3.5 Channel Bias Voltage Definition Command Structure

BIAS, BV

Syntax: **BV** *hs* Channel Specifier *ds* numerical value

Example: **BV 1,4500**

Specifiers: Channel specifiers: **1, 2, 3, and 4**
Numerical value range: -10000 to 10000
assumed units: millivolts

Description: This verb defines a bias voltage as a function of a specified channel. The bias voltage is available at the rear panel connector of the same name. This voltage is present at the rear panel connector whenever the 8003 is making a measurement on that channel. Up to four different voltages may be defined to correspond to the four channels.

3.3.6 Sensor Calibration Command Structure

CAL

Syntax: **CAL** *hs* Sensor Specifier [*us* modifier] **EOL**

Example: **CAL B;srq EOL**

Specifiers: **A, B, or C**

Modifiers: This modifier is to request that a service request be sent upon completion of the Sensor Calibration.

Modifier name: **SRQ**

Modifier Syntax: **SRQ**

Description: This verb defines and initiates a Sensor Calibration.

If the SRQ modifier is received, the 8003 will calibrate the specified Sensor. When the calibration is complete, the event complete bit is set in the external status register and the service request and the external status bits are set in the instrument status byte.

3.3.7 Channel Definition Command Structure

CHAN, CH

Syntax: **CH** *hs* Channel Specifier [*ds* Sensor Specifier] [*us* modifiers] .. [*us* modifiers]

Example: **CHAN 2,B/C;on;meas;CHAN 1;off;CHAN 3;norm;on**

Specifiers: Channel Specifiers: **1, 2, 3, and 4**

Sensor Specifiers: **A, B, C, A-B, A-C, B-A, B-C, C-A, C-B, A/B, A/C, B/A, B/C, C/A, and C/B**

Modifiers: This modifier defines the measurement to be made in absolute units (non-normalized).

Modifier name: **MEAS, M, ABS**

Modifier Syntax: **MEAS**

This modifier defines the measurement to be made in relative units (meas data - path cal).

Modifier name: **NORM, N, -PC**

Modifier Syntax: **NORM**

This modifier turns on a specified channel.

Modifier name: **ON, +**

Modifier Syntax: **ON**

This modifier turns off a specified channel.

Modifier name: **OFF,-**

Modifier Syntax: **OFF**

Description: This verb describes attributes to a channel. Such features as sensor assignment and turning a channel on or off are defined by a command string beginning with this verb.

3.3.8 Cursor Definition Command Structure

CURSOR, CUR

Syntax: **CUR** *hs* Channel Specifier [*us* modifier]..*[us* modifier]

Example: **CUR 4;on;sch? max**

Related Command:

SWP

Specifiers: Channel specifiers: **1, 2, 3, and 4**

Modifiers: This modifier turns on a cursor for the specified channel making the SWEPT measurement.

Modifier name: **ON,+**

Modifier Syntax: **ON**

This modifier turns off a cursor for the specified channel making the SWEPT measurement.

Modifier name: **OFF,-**

Modifier Syntax: **OFF**

This modifier sets up a search condition for the cursor on the specified channel. The addition of the question mark affixed to the end of the SEARCH modifier is a query flag. If the query flag is set, the measurement will be made and the next time that the 8003 is addressed to talk it will output the value of the cursor as defined by the search request. The format of the returned data is described for each type of search request below.

Modifier name: **SEARCH, SEARCH?, SCH, SCH?**

Modifier Syntax: **SCH[?] us SEARCH MOD**

SEARCH MOD: **MAX**

FULL Modifier Syntax: **SCH[?] us MAX**

query value returned: **freq, data EOL**

freq: freq = D.ddd Where D is zero to 6 digits. The value represents the frequency of the maximum power point in the trace in units of MHZ.

data: data = $\pm d$ where D is zero to three digits to the right of the decimal point and three digits to the left. The assumed units are dBm or dB depending upon the measurement mode.

SEARCH MOD:	MIN
FULL Modifier Syntax:	SCH[?] us MIN
query value returned:	freq, data EOL
freq:	freq = D.ddd Where d is zero to 6 digits. The value represents the frequency of the minimum power point in the trace in units of MHZ.
data:	data = \pm D Where D is zero to three digits to the right of the decimal point and three digits to the left. The assumed units are dBm or dB depending upon the measurement mode.
SEARCH MOD:	RIGHT, RT
FULL Modifier Syntax:	SCH[?] us RT hs numerical value
numerical value range:	-90.00 to +90.00
numerical resolution:	0.01
assumed units:	dBm, dB
query value returned:	freq, data EOL
freq:	freq = D.ddd Where D is zero to 6 digits. The value represents the frequency of the cursor in units of MHZ. This value is returned here for confirmation.
data:	data = \pm D Where D is zero to three digits to the right of the decimal point and three digits to the left. The assumed units are dBm or dB depending upon the measurement mode.
SEARCH MOD:	LEFT, LT
FULL Modifier Syntax:	SCH[?] us LT hs numerical
value numerical value range:	-90.00 to +90.00
numerical resolution:	0.01
assumed units:	dBm, dB
query value returned:	freq, data EOL
freq:	freq = D.ddd Where D is zero to 6 digits. The value represents the frequency of the cursor in units of MHZ. This value is returned here for confirmation.
data:	data = \pm D Where D is zero to three digits to the right of the decimal point and three digits to the left. The assumed units are dBm or dB depending upon the measurement mode.

8003 Precision Scalar Analyzer

SEARCH MOD:	BW
FULL Modifier Syntax:	SCH[?] us BW hs numerical
value numerical value range:	-90.00 to +90.00
numerical resolution:	0.01
assumed units:	dBm, dB
query value returned:	freq 1, freq 2, freq bw, data EOL
freq 1:	lower frequency of bandwidth in MHZ. The format is D.ddd where D is zero to six digits.
freq 2:	upper frequency of bandwidth in MHZ. The format is D.ddd where D is zero to six digits.
freq BW:	bandwidth in MHZ. The format is D.ddd where D is zero to six digits.
data:	\pm D.ddd dB bandwidth (specified by host computer and returned here for confirmation). Where D is zero to 3 digits to the left of the decimal point. The value is returned to the host computer for confirmation.
SEARCH MOD:	FLAT
FULL Modifier syntax:	SCH? hs FLAT
query value returned:	freq, data EOL
freq:	freq = D.ddd where D is zero to 6 digits. The value represents the current cursor frequency in MHz
data:	Finds the curve flatness where flatness = maximum trace power minus minimum trace power. Data format = D where D is zero to three digits to the left of the decimal point, and two digits to the right of the decimal point. The assumed units are dBm or dB, depending on the measurement mode.

This modifier defines the frequency of the cursor. The cursor will be placed at the frequency specified by this modifier.

Modifier name:	FREQ, FREQ?
Modifier Syntax:	FREQ[?] [<i>hs</i> numerical value]
numerical value range:	limited by the signal source if the source is supported upon the private bus. Otherwise the frequency range is 1.000 MHZ to 99.000 GHZ. If the query flag ("?") is selected, the next time the 8003 is talk addressed the instrument will return the cursor data in the following form:
query value returned:	freq, data EOL
freq:	freq = D.ddd Where D is zero to 6 digits. The value represents the frequency of the cursor in units of MHZ.
data:	±ddd.dd [units are dB(m)]
Description:	This modifier qualifies that it is the delta cursor which is to be modified.
Modifier name:	DELTA
Modifier Syntax:	DELTA <i>ds</i> state
State definition:	ON , + = delta cursor on
Full Syntax:	CUR <i>hs</i> [chan specifier] <i>us</i> DELTA state

Description: This verb defines a cursor function for a specified channel. The feature is specified via the modifiers for this verb. An example of a feature is to place the cursor at the maximum power point in a swept trace for a given channel

3.3.9 Instrument Preset Command Structure

<Device Clear>

Syntax: A standard GPIB device clear (either selective or general) will preset the instrument.

Examples: **CLEAR 704:** for HP Series Controllers

WRITE GPIB CMD(Dcl): for IBM Series Controllers running TBASIC

Description: A GPIB device clear will cause the instrument to perform an instrument preset. The instrument will go to the following default state:

Function	Default Setting
Cursor	
Cross Cursor:	OFF, frequency at 10000 MHz
Delta Cursor:	OFF
Markers:	OFF
Active Channel:	1
Sensor	
Sensor Mode:	DC
Sensor Specific for Source of Frequency:	Back Panel Swp Input
Sensor Frequency:	0.05 GHz
Sensor Cal Factor:	0
Sensor Offset:	0
Sensor Full Band Path Cal Option:	NO
Display	
Setup:	Swept Mode
Color Intensity:	Red, Green, Blue are bright
Graticule Color:	Green
Frequency Label:	ON
Title:	OFF
Channel	
Mode:	Swept Frequency
Parameter:	A, B, C, A/B for channels 1 through 4.
Color:	Cyan, Red, Yellow, Magenta for channels 1 through 4 respectively
Format:	dB mode
Memorized Trace:	0
Measurement:	Absolute Measurement
Average:	OFF, average factor = 8
Smoothing:	OFF, smooth apert = 5%
Continue Auto Scale:	OFF
Scale per Division:	20 dB
Reference Position:	Center
Reference Level:	0 dB
Bandwidth Search Value:	-3.00 dB
Channel Search Level:	-3.00 dB
CW Mode Setup:	REL OFF
Max Hold:	OFF
Min Hold:	OFF
Channel Title:	OFF
Limit Line:	OFF
Modulate Bias Voltage:	0 volt

<u>Function</u>	<u>Default Setting</u>
Source	
Signal Source Mode:	Start/Stop Swept Freq
Start Frequency:	Sweeper Start Frequency or 1 MHz if not controlled by the 8003
Stop Frequency:	Sweeper Stop Frequency
Sweep Time:	200 ms
RF Power Level:	OFF, minimum RF level of the signal source or 0 dBm if not controlled by the 8003.
Source Modulation:	OFF

The following instrument settings are **not** changed during an instrument preset:

- All GPIB addresses (Analyzer, Source, Printers, and Plotters)
- Sensor linearity calibrations
- Trace Memories
- Path Cal Memories

3.3.10 Disable Private Bus Command Structure

DISABLE

Syntax: **DISABLE**

Related Command:

ENABLE

Description: This verb disables the private bus. When sent, the 8003 private bus becomes inactive. An Enable command must be sent or a power down/power up cycle must be executed to enable the private bus.

3.3.11 Enable Private Bus Command Structure

ENABLE

Syntax: **ENABLE**

Related Command:

DISABLE

Description: This verb enables the private bus. When sent, the 8003 private bus becomes active. A Disable command must be sent to disable the private bus.

3.3.12 External Status Register Query Command Structure

*ESR?

Syntax: *ESR?

Example: *ESR?

Description: This verb is the standardized COMMON external status register query command as defined by IEEE 488.2 1988. When talk addressed after receiving the command, the 8003 will output the value of its external status register. The return value is defined as follows:

status: **EOL**

Where status is an integer in the range of 0 to 128.

The description of the individual bits and their decoding can be found in Section 3.3.32.

3.3.13 Fixed Frequency Source Mode Definition Command Structure

FIXED

Syntax: **FIXED** [*us modifier*].[*us modifier*]

Examples: (See page 3-66 in the SWPF command description for a more complete programming example of the UPD modifier.)

Related Command:

POWER

Modifiers: This modifier defines a CW frequency for the FIXED frequency mode of signal source. The query flag ('?') affixed to the cw frequency modifier queries the value of the cw frequency. If set, the next time the 8003 is talk addressed it will output the value of the cw frequency in MHZ. The format of the returned data is:

D.dddddd: Where D is zero to 6 digits and the assumed units are MHZ

Modifier name: **FREQ, FREQ?, FR, FR?, CW, CW?**

Modifier Syntax: **CW[?]** [*ds numerical value*]

Numerical value range: Dependent upon the signal source if the source is supported on the 8003 private bus. If not supported, the range is 1 MHZ to 99 GHZ

This modifier defines a POWER LEVEL for the fixed frequency mode of signal source. The query flag ('?') affixed to the power level modifier queries the value of the power level. If set, the next time the 8003 is talk addressed it will output the value of the power level in dBm.

The resolution is 0.01 dBm. The format of the returned data is:

±D.dd

where D is zero to three digits and the assumed units are dBm

Modifier name: **LEVEL, LEVEL?, PL, PL?**

Modifier Syntax: **PL[?]** [*ds numerical value*]

Numerical value range: Dependent upon the signal source if the source is supported upon the 8003 private bus. If not supported then the range is -99 to +99 dBm.

The update modifier decouples analyzer frequency updates from sweeper frequency updates. This is most commonly used when the analyzer and sweeper are set to different frequencies, as in mixer or frequency multiplier measurements. The analyzer normally uses frequency information to change the operating frequencies of the sweeper, annotate x-axis of the swept

display, apply correct Cal Factors to the reading, take the correct portions of trace memories and path cal memories, and fix cursors and markers. The update modifier allows independent control of the sweeper frequencies and all other frequency related analyzer functions. If the modifier UPD ON is included once with the SWPF, SWPS, or FIXED verbs, then all subsequent uses of those verbs will update the sweeper frequency along with the analyzer frequency. If the modifier UPD OFF is included once with the above verbs, then all subsequent uses of those verbs will change only analyzer frequency parameters.

Modifier name: **UPD**

Modifier syntax: **UPD** *hs* state

State definition: **ON, OFF**

Send the following commands to modify both the sweeper and analyzer frequencies to 2000 MHz

FIXED;UPD ON

FIXED;2000

Send the following commands to modify only the analyzer frequency to 6000 MHz.

FIXED;UPD OFF

FIXED;6000

Description: This verb places the signal source mode to fixed frequency. This is an instrument wide command and, as such, has no channel or sensor specifiers. However there are many parameters associated with the source mode. These are defined by the modifiers which follow the verb.

3.3.14 Graph Display Definition Command Structure

GRAPH, GPH

Syntax: **GPH**

Example: **GRAPH**

Related Command:

SWP

Description: This verb places the 8003 display in the graph mode. There are no channel or sensor specifiers and no modifiers.

3.3.15 Instrument Identifier Command Structure

***IDN?**

Syntax: ***IDN?**

Example: ***IDN?**

Description: This verb is the standardized COMMON identify query command as defined by IEEE 488.2 1988. When talk addressed after receiving the command, the 8003 will output a string that identifies itself as the 8003 SNA. The return value is defined as follows:

Giga-tronics,8003,0,Software rev,Software rev date**EOL**

Where:

- Giga-tronics is the manufacturer's name
- 8003 is the model number
- 0 is an unused field
- the software rev is the revision number such as 3.01
- the software rev date is the date of the software revision

8003 Precision Scalar Analyzer

3.3.16 Input Command Structure

INPUT

Description: This verb inputs frequency, trace, pathcal, and cal factor information to the 8003 for use in specific test routines. When information is downloaded, the 8003 needs to know the span of the frequency range that the data represents. The first two values expected by the analyzer, therefore, will be the Start and Stop frequencies. The ensuing data will then represent values of power evenly spaced over the specified range. The first data item is a power reading at the start frequency, and the last data item is a power reading at the stop frequency. 512 power values are expected for trace memory, while 4096 values are required for sensor Pathcal and Cal Factor data. The units for frequency are MHz, and the units for power are dB. All data must be separated by a comma and end with a line feed.

Syntax: **INPUT** *us* memory modifier *hs* sensor/trace specifier

<i>Modifiers:</i>	Trace specifiers:	0 through 9
	Sensor specifiers:	A, B, C
	Pathcal specifiers:	A, B, C
	Calfactor specifiers:	A, B, C
	Trace:	This refers to the 10 trace memories that can be used for ratio measurements with any channel (see Section 2.3.7 on page 2-14 in the OPERATION Chapter of this manual for a complete description).
	Pathcal:	This refers to the sensor's path calibration memory (see Section 2.8.2 under <i>Frequency Response Correction</i> for a complete description).
	Calfactor:	This refers to the sensor's calibration factor data (see the paragraph starting at the bottom of Section 2.12 on page 2-95 in the OPERATION chapter of this manual for a complete description).

Data Input Format:

START FREQ,STOP FREQ (MHz)	D.ddd
then 512 data points for TRACE (dB)	±ddd.dd
then 4096 data points for PATHCAL	±ddd.dd
then 4096 data points for CALFACTOR	±ddd.dd
	D = 0 to 6 digits

Example: **start frequency,stop frequency,data,(start freq),...,data(stop freq)**

Immediately following the **INPUT** command string, the analyzer expects the data with the above format.

Syntax Examples:

```
INPUT,TRACE 4  
INPUT;PATHCAL B  
INPUT;CALFACTOR C
```

Programming Examples:for HP 200 or 300 series controllers:

```
OUTPUT 704;INPUT;TRACE 4,Start_freq,stop freq,Data_array(*)
```

Related Command: **OUTPUT**

3.3.17 Key Stroke Emulation Enable/Disable Command Structure

KEYEM, KE

Syntax: **KEYEM** *hs* modifier

Modifiers: This modifier turns on the key stroke emulation mode.

Modifier name: **ON,+**

Modifier Syntax: **ON**

This modifier turns off the key stroke emulation mode.

Modifier name: **OFF,-**

Modifier Syntax: **OFF**

Description: Key Stroke Emulation is a feature that allows the GPIB controller to access 8003 functions that are not available through normal GPIB commands. This is a special mode wherein a sub-set of ASCII characters are interpreted as the 36 keys on the front panel of the 8003 (see Figure 3-1 on page 3-1).

There are two completely separate methods for entering and exiting the key emulation mode which cannot be interchanged. In the first method, the controller sends a KEYEM ON command and then asserts a global local. The GPIB 488 REN line is sent false and all characters are passed on as key strokes, just as if they were entered from the front panel. It should be kept in mind that once the key emulation mode is turned on, any commands sent to the 8003 while it is in local (remote enable line false) will be interpreted as a key stroke. It is still possible to program the instrument in remote while the key emulation mode is enabled. This is done by placing the 8003 in remote (remote enable set true and listen addressed). This allows the host controller to switch between the true remote state and the local key stroke emulation mode without disabling the key stroke emulation mode. The feature is disabled by sending a KEYEM OFF command.

Although the above method is easy to do and will work no matter what data must be sent to the 8003, it does require the controller to place all of the instruments on the bus in the local mode with the global local command. This can cause certain devices to change their settings which might not be desirable.

The second method does not require the entire bus to go into the local mode. It can be accessed as described above but, instead of a global local command, a device specific go to local command is used. Characters will then be treated as key strokes until a reserved character [in this case an asterisk (*)] is received to exit the key emulation mode and start converting characters back into normal GPIB commands. Under the circumstances described in #2 on the next page, the timing of the * character must be programmed so as not to prematurely abort some keyboard emulation function that might still be in process. This means that if the buffer were full with 16 characters, the routine would not see the * reserved character and would continue to try and interpret GPIB commands as key strokes.

8003 Precision Scalar Analyzer

Because the key stroke emulator is implemented as a succession of key strokes, certain limitations should be kept in mind:

1. The **go to local** command just before key stroke emulation will terminate most GPIB functions still in progress. A waiting time of at least 1 second between the last GPIB command and the go to local command is recommended. Likewise, a small 10 millisecond waiting period after the go to local command has been given is recommended before giving key stroke emulation commands.
2. The key stroke emulator buffers a maximum of 16 characters or individual key strokes. The buffer is emptied serially as the instrument completes each keystroke emulation. If the buffer is full, any extra key strokes sent to the instrument will be lost. The time it takes to empty the buffer varies depending on the key stroke function requested. Some key strokes such as entering limit lines are processed quickly, while others such as plotting take a longer time to process. It is up to the programmer to make sure that the instrument has digested the key strokes in its buffer before sending new key strokes.
3. When given a **go to remote** command after key stroke emulation, the analyzer will wait for the key stroke commands to finish execution before processing any further bus commands. This feature allows a program to automatically wait for the execution of slow key stroke commands (such as plotting). See the example on the next page for use of this feature to separate two key stroke commands when the first takes an indeterminate amount of time.

Table 3-1: Definition of ASCII Codes

Key Stroke	Definition	Key Stroke	Definition	Key Stroke	Definition
A	soft 1	O	Memory	5	5
B	soft 2	P	Start freq	6	6
C	soft 3	Q	Power	7	7
D	soft 4	R	Stop freq	8	8
E	soft 5	S	Sweep time	9	9
F	soft 6	T	Preset	a	Enter off
G	soft 7	U	Config	b	Backspace
H	soft 8	-	Minus	c	MHZ/msec/dBm
I	Define	.	Decimal pt	d	GHZ/sec/dB
J	Meas	0	0	e	Channel 1
K	Scale	1	1	f	Channel 2
L	Disp	2	2	g	Channel 3
M	Cal	3	3	h	Channel 4
N	Cursor	4	4	i	Channel off

Examples

Simple example using an HP Series 300 Controller:

```

100 OUTPUT 704;KEYEM ON! enable keystroke emulation
110 !
120 WAIT 1! always wait before go to local command
130 LOCAL 7 ! send remote enable false
140 WAIT .01 ! always wait 10 ms after local command
150 OUTPUT 704;LDA! key stroke emulation for plotting
160 ! current display
170 REMOTE 704! exit key stroke emulation mode
180 !
190 OUTPUT 704;KEYEM OFF! disable keystroke emulation

```

More complex example using an HP Series 300 Controller (see Figure 3-2):

```

100 CLEAR 704 ! Instrument preset
110 OUTPUT 704;SWPF:start 2000;stop 4000;level 0;level
120 ! Sweep from 2 to 4 GHz at 0 dBm
130 OUTPUT 704;CH 2;off;CH 3;off;CH 4;OFF
140 OUTPUT 704;SWP 1;scale 1;rp 0;r1 0
150 ! Manually scale ch 1, turn other channels off
160 !
170 OUTPUT 704;KEYEM ON! Enable key stroke emulation
180 !
190 ! Local mode turns key stroke emulation on
200 WAIT 1! always wait before a local command
210 LOCAL 7 ! send remote enable false
220 WAIT .01 ! always wait 10 ms after local command
230 !
240 ! First, set up a limit line with 2 segments:
250 OUTPUT 704;LDBC2d4d-4d
260 ! First half sets up slope limit with 2 GHz start freq
270 ! and +/- 4 dB upper and lower limits
280 WAIT 1! wait 1 second to process key strokes
290 OUTPUT 704;3d3d-3d
300 ! Second half sets 3 GHz stop freq and +/-3 dB limits
310 WAIT .5! wait to process key strokes
320 OUTPUT 704;LDBB3d3d-3d4d
330 ! Now, set up flat limit from 3 to 4 GHz with
340 ! +/- 3 dB upper and lower limits
350 WAIT 1! wait to process key strokes
360 OUTPUT 704;LDA! Turn limit lines on
370 WAIT 1! wait to process key strokes
380 !
390 OUTPUT 704;LCA! plot the current display
400 !
410 ! Use go to remote feature to automatically wait
420 ! for the end of the plotting function
430 REMOTE 704! go to remote
440 OUTPUT 704;CH 1;ON! Dummy bus command is not
450 ! executed until analyzer finishes plotting
460 !
470 ! Now continue with other key stroke functions
480 WAIT 1
490 LOCAL 7 ! go to local sequence
500 WAIT .01
510 OUTPUT 704;LAEB! turn smoothing on

```

8003 Precision Scalar Analyzer

```
520 REMOTE 704! done with key stroke emulation
530 !
540 OUTPUT 704;KEYEM OFF! disable key stroke emulation
```

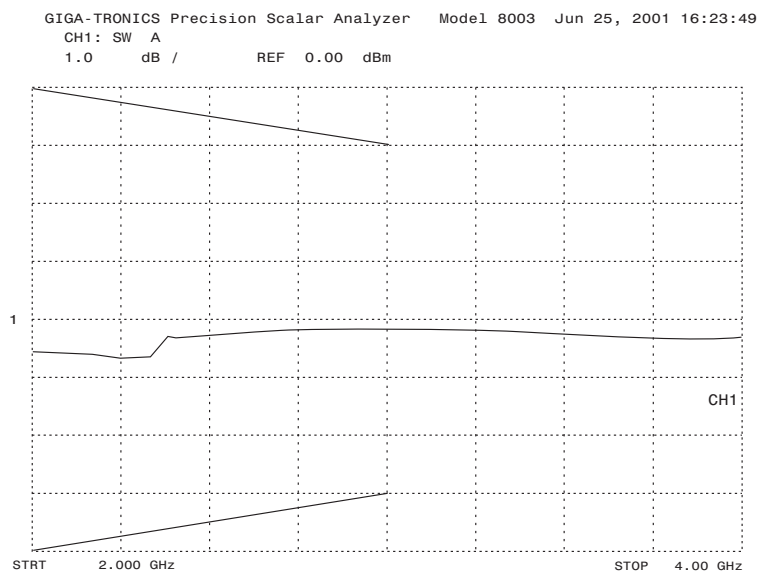

Figure 3-4: Plot Obtained Using More Complex HP Series 300 Prg. Example

3.3.18 Memory Command Structure

MEMORY

Syntax: **MEMORY** [*us* modifier] [*ds* numeric value]

Examples: **MEMORY;STORE 1**
Store front panel setting in store/recall memory 1

MEMORY;RECALL 1
Recall front panel setting from store/recall memory 1

Modifiers: Stores current front panel state in store/recall memory n.

Modifier name: **STORE**

Modifier syntax: **STORE** [*ds* numeric value]

valid numeric values: 0 through 9

assumed units: no units (these are store/recall memories)

Recalls current front panel state from store/recall memory n.

Modifier name: **RECALL**

Modifier syntax: **RECALL** [*ds* numeric value]

valid numeric values: 0 through 9

assumed units: no units (these are store/recall memories)

Description: The memory verb stores and recalls the entire instrument front panel state in the instrument's store and recall memories.

3.3.19 Measurement Query Command Structure

OUTPUT, OP

Output Current Data Syntax:

OP *hs* Channel Specifier *us* modifier [*us* modifier]

Output Current Data:

One form of the OP verb defines a measured data output. The data captured will be the data measured on the channel indicated by the channel specifier which follows the output verb. The format of the measured data depends upon the measurement mode and the output request. If the channel is making a swept measurement and the data returned represents the measured trace, the format is:

data(freq min),data(freq n),...,data(freq max) **EOL**.

See the section describing the swept measurement verb **SWP** on page 3-54 for more details. If the channel is making a CW measurement and the data represents the measured data point, the format is data**EOL**.

See the section describing the **CW** power measurement verb **POWER** on page 3-36 for more details. If the request is for cursor power measured at the cursor frequency, the format definition can be found on page 3-31 using the **CURP** modifier.

Output Current Data Specifiers:

Channel Specifiers are **1**, **2**, **3**, and **4**

Output Current Data Modifiers:

This modifier defines the number of data items to be returned when the measured data is requested for output to the host computer.

Modifier name:	ITEMS
Modifier Syntax:	ITEMS <i>ds</i> numerical value
valid numerical values:	1 to 512
assumed units:	no units

This modifier is used if the channel is making a swept measurement. The format of the returned data is detailed in the section describing the swept measurement verb **SWP** on page 3-54.

This modifier is to specify that a service request be sent upon completion of the measurement defined for this channel.

Modifier name:	SRQ
Modifier Syntax:	SRQ

Once the SRQ modifier is received, the 8003 will make the measurement specified for this channel. If the number of averages defined for this channel has been satisfied, the event complete bit is set in the external status register and the service request and the external status bits are set in the instrument status byte.

The **LIMIT** modifier reads the PASS/FAIL status of a limit line test. This command assumes that a limit line has been previously defined and turned on (see **SWP** command, **LIMIT** modifier). When this command is received, the analyzer will read the PASS/FAIL status of the indicated channels limit line test and wait to be talk-addressed by the controller. When talk-addressed, the analyzer will return the string **PASS** or **FAIL** according to the results of the limit line test (**PASS** indicates that the channel's trace was within the limits, **FAIL** indicates outside the limits).

Modifier name: **LIMIT**
Modifier syntax: **LIMIT**
return data format: **PASS** or **FAIL**

This modifier is to request that the power be measured at the cursor position (assumes channel is in swept mode and that the cursor is turned on). The data returned will be in the following format:

cursor data = freq, data **EOL**

freq = F

data = \pm D

where F is a variable field number with three digits to the right of the decimal point in MHz, and D is a variable field number with three digits to the right of the decimal point in dBm or dB.

Modifier name: **CURP**
Modifier Syntax: **CURP**

Output Current Data Example:

OP 3;srq;curp EOL

Output Current Data Related Command:

SWP

Output Stored Data:

The second form of the **OP** command sends TRACE, PATHCAL, or CALFACTOR data from the 8003 to the controller. The data format is as follows:

start freq, stop freq, data_{START DATA},, data_{FREQ N},....data_{STOP FREQ}

Output Stored Data Syntax:

OP *us* memory specifier *hs* sensor/trace specifier

8003 Precision Scalar Analyzer

Output Stored Data Specifiers:

Memory specifiers are **TRACE**, **PATHCAL**, and **CALFACTOR**
Sensor specifiers are **A**, **B**, and **C**
Trace specifiers are 0 through 9

 **NOTE:** **TRACE** uses a Trace specifier, **PATHCAL** and **CALFACTOR** use Sensor specifiers.

Output Stored Data Format:

START FREQ,STOP FREQ (MHz)	D.ddd
then 512 data points for TRACE (dB)	±ddd.dd
then 4096 data points for PATHCAL	±ddd.dd
then 4096 data points for CALFACTOR	±ddd.dd

D = 0 to 6 digits

Output Stored Data Examples:

OUTPUT;TRACE 5
OUTPUT;PATHCAL A
OUTPUT;CALFACTOR C

Output Stored Data Related Command:

INPUT

Description: There are two forms of Output commands. One form outputs currently measured data. The other form outputs stored data such as Trace memories, Path Cal memories, and sensor Cal Factor memories. These forms have completely different syntaxes but share the same verb. Users are cautioned to make note of the difference between the two. The Output Current Data and the Output Stored Data descriptions starting on page 3-31.

3.3.20 Plot Command Structure

PLOT

Syntax: **PLOT** us modifier [us modifier] [us SRQ]

Examples: **PLOT;ALL;SRQ**

Full size plot of all parameters, assert SRQ when done.

PLOT;LOWR;SRQ

Plot in lower right quadrant, assert SRQ when done.

PLOT;CUSTOM;GRID;FREQ_LB;SRQ

Custom plot of grid and frequency labels only, assert SRQ when done.

PLOT;CUSTOM;SCALE

Make analyzer read new P1, P2 plotter coordinates

PLOT;CUSTOM;DEF_LOGO;NEW LOGO

Plots NEW LOGO instead of Giga-tronics logo

Modifiers: Does a full size plot with all parameters

Modifier name: **ALL**

Modifier syntax: **ALL**

Modifier Description: Does a plot in the upper left (**UPL**), upper right (**UPR**), lower left (**LOWL**), or lower right (**LOWR**) quadrants of the paper.

Modifier name: **UPL, UPR, LOWL, or LOWR**

Modifier syntax: **UPL, UPR, LOWL, or LOWR**

Modifier Description: Does a special plot of trace only (**SP_TRACE**), labels only (**SP_LABEL**), or frequencies only (**SP_FREQ**).

Modifier name: **SP_TRACE, SP_LABEL, or SP_FREQ**

Modifier syntax: **SP_TRACE, SP_LABEL, or SP_FREQ**

Modifier Description: Asserts GPIB **SRQ** at the end of a plot. The system controller would normally use an interrupt service routine to take action once the analyzer asserts **SRQ**. An **SRQ** can be cleared by doing a GPIB serial poll of the analyzer.

Modifier name: **SRQ**

Modifier Description: Does a custom plot with user defined features. The modifier **CUSTOM** should be followed by a set of modifiers that define the custom plot (see examples next page).

8003 Precision Scalar Analyzer

Modifier name: **CUSTOM**
Modifier syntax: **CUSTOM** [*us* modifier] ... [*us* modifier]

Custom Modifiers:

Modifier Description: See page 2-29 for a brief description of the **GRID**, **FREQ_LB**, **SUMMARY**, **SCALE**, and **LABEL** modifiers.

Modifier name: **GRID**, **FREQ_LB**, **SUMMARY**, **SCALE**, and **LABEL**

Modifier syntax: **GRID**, **FREQ_LB**, **SUMMARY**, **SCALE**, and **LABEL**

Modifier Description: The trace modifier for **CUSTOM** determines which channel(s) are plotted.

Modifier name: **TRACE**

Modifier syntax: **TRACE** *ds* numerical value

valid numerical value: 0 to 4

assumed units: no units (This is the channel number)

Modifier Description: The logo modifier for **CUSTOM** plots the Giga-tronics logo and date at the top of the plot.

Modifier name: **LOGO**

Modifier Description: The `def_logo` modifier for **CUSTOM** plots a user-defined string instead of the Giga-tronics logo.

Modifier name: **DEF_LOGO**

Modifier syntax: **DEF_LOGO** *us label*
where *label* is an alphanumeric string up to 50 characters long.

Description: The plot verb makes various plots of the display on a plotter connected to the analyzer's private GPIB bus. For a detailed description of the different types of plots, please see the Plot & Print Softkey description starting on page 2-27 in the OPERATION chapter of this manual. Since plots may take more than a minute to complete, it is strongly advised to use the SRQ function to detect when the plot is finished (see the example of a typical Plotter Command program on page 3-35.)

Plotter Command Programming Example

```

10  !*****
20  ! PLOTTER COMMAND DEMONSTRATION
30  !*****
40  !
50  CLEAR 704! device clear presets analyzer
60  WAIT 4
70  !
80  OUTPUT 704;SWP 1;A:on;SWP 2;A:off;CHAN 3;off;CHAN 4;off
90  OUTPUT 704;SWPF;start 2000;stop 4000;level 10;level on;swpt 300
100 WAIT 3! wait for sweeper to digest changes and output clean sweep
110 OUTPUT 704;SWP 1;scale auto! autoscale trace
120 WAIT 1
130 !
140 !.....
150 BEEP
160 INPUT Press RETURN when plotter is ready for demo ... , Inp#
170 ! First set up controller to use SRQ s
180 ON INTR ? GOSUB Service srq
190 ENABLE INTR 7;2
200 !
210 GOTO Jumparound
220 ! Full size plot of entire display
230 OUTPUT 704;PLOT;all;srq
240 GOSUB Wait for srq
250 !
260 PAUSE
270 ! Plot entire display in lower right hand quadrant
280 OUTPUT 704;PLOT;lowr;srq
290 GOSUB Wait for srq
300 !
310 PAUSE
320 ! Custom plot with trace and frequency readouts only
330 OUTPUT 704;PLOT;custom;trace 1;freq 1b;srq
340 GOSUB Wait for srq
350 !
360 PAUSE
370 Jumparound:
380 ! Custom plot with logo changed
390 OUTPUT 704;PLOT;custom;grid;trace 1;def logo MY COMPANY NAME1234
400 ! Note that HP Basic requires double quotes to insert a quotation
410 ! mark within a quoted string
420 STOP
430 !.....
440 !
450 ! Various subroutines:
460 !
470 Wait for srq:! This subroutine waits until an SRQ occurs
480     Received srq=0! Clear flag to stay in next loop
490     WHILE Received srq=0! Exit loop only when srq service sets flag
500     END WHILE
510     Status1=SPOLL(704)! Serial poll clears srq message
520     ENABLE INTR 7;2! Re-enable interrupts
530 RETURN
540 !
550 Service srq:
560     Received srq=1! Set srq flag when interrupt received
570 RETURN
580 !.....
590 END

```

3.3.21 CW Power Measurement Command Structure

POWER

Syntax: **POWER** [?] *hs* channel specifier [*ds* sensor specifier] [*us* trigger mode] [*us* modifiers]

Specifiers: Channel specifier: 1 through 4

Sensor specifier: **A, B, C, (A/B, A/C, B/A, B/C, C/A, C/B, A-B, A-C, B-A, B-C, C-A, or C-B** allowed for trigger mode **TØ** only)

Trigger Modes:

Trigger mode syntax: TØ, T1, T2, T3

Default trigger mode: TØ

General Description:

Once the trigger mode is set, the 8003 will remain in that trigger mode until another trigger mode command is sent. If the **POWER** command is sent with one of the fast data modes (T1 through T3), the analyzer will freeze its display to maximize data rate through the GPIB bus. When any one channel is put in one of the fast data modes, all channels change to the same fast data mode. To place the instrument in the standard **TØ** mode with display updates, do any of the following:

- Send the **POWER** command with mode **TØ**
- Send a **DEVICE CLEAR** bus command to the analyzer
- Send an **INTERFACE CLEAR** bus command
- Put the instrument in **LOCAL** mode - either manually or over the bus

In the fast data modes (T1 through T3), it is advisable to use the **RDTEMP** command to periodically update low level temperature and offset drift correction. See the description for the **RDTEMP** command in Section 3.3.22.

Normal CW Mode:

Trigger mode name: **TØ**

This is the analyzer's default power-up mode. In this mode, the analyzer free-runs at a relatively slow data rate. The mode offers familiar power meter functionality to the user with channel ratioing and differences, averaging, max and min holds, and relative measurements - although at a slower reading rate than the fast CW modes described below. When the analyzer receives an **OUTPUT** [*channel#*] command over the bus, it will send the current power reading for that channel to the controller (see the **OUTPUT** command description in Section 3.3.19 for more information). The power reading is corrected for Cal Factor, temperature, and low-level offsets. Reading rate is fairly slow (greater than 10 readings per second). The analyzer will wait until it is talk addressed, and then it will return the reading in the format \pm ddd.dd in dB.

Fast Free-run CW Mode:

Trigger mode name: **T1**

In this mode, the analyzer makes high speed CW power measurements. The analyzer free runs but does not update the display to maximize measurement speed. The free-run mode is the simplest to use, and is intended for ATE measurements where the timing of the reading is not extremely critical. All four channels may be used and configured in any sequence of sensors but channels are restricted to single-sensor-per-channel measure-

ments only (no ratios or differences). Every measurement cycle, the analyzer takes a reading for each active channel (or n readings if the AVG n modifier is specified). Note that the averaging number may be different for each channel. Whenever the analyzer is talk addressed, it sends the most recent (averaged) reading from each active channel to the controller. The OUTPUT command is not required before talk-addressing the analyzer. Unlike the TØ mode, the T1 mode will send the data for all active channels when talk addressed. The data returns in the format:

±ddd.dd,±ddd.dd,...,±ddd.dd

with one data item for each active channel separated by commas. The T1 mode is capable of measurement speed in excess of 180 measurements per second.

Fast Bus Triggered CW Mode:

Trigger mode name: **T2**

This is also a high speed CW reading mode with display updates suppressed. This mode is very similar to the T1 mode described above except that the analyzer does not free run, but instead waits for a trigger from the controller. This allows precise timing of measurement events in the system. The trigger is the GPIB Group Execute Trigger (GET) command. Note that there are both addressed and universal versions of the GET command so that just the analyzer, or all instruments on the bus can be triggered. When the trigger is received, the analyzer takes a reading on each active channel (or n readings if AVG n is specified) and then waits to be talk addressed. When talk addressed, the analyzer sends each channel's data to the controller in the serial fashion described above. Note that in the triggered mode, the 8003 expects the controller to read the data after the trigger is received. In the Free Run Mode (T1), the controller never needs to read the data.

An additional capability in Triggered Mode is the use of data buffers for each active channel. Buffering the data allows the analyzer to measure even faster since it does not have to output the data between readings. Buffering is requested by adding the ITEMS n modifier to the **POWER** command (see the ITEMS modifier under the T2 MODIFIERS section on page 3-40).

For full GPIB handshaking with buffered measurements, see the SRQ modifier description under the T2 MODIFIERS section on page 3-40 also.

8003 Precision Scalar Analyzer

Fast TTL Triggered CW Mode:

Trigger mode name: **T3**

This mode is exactly like the T2 mode described above except that the analyzer is triggered by a TTL signal provided to the 8003 rear panel BNC input marked INPUT 1/TTL LEVELS. The mode should be used when it is more convenient, or more accurate to time the measurement by a digital TTL signal, rather than a GPIB bus command. The measurement is edge triggered - that is, the 8003 waits to see a TTL-transition from low to high at the input before triggering the reading. The TTL-high signal must be present for at least 500 ms for the analyzer to see it. Buffers may be used in this mode and are described in the ITEMS modifier description for T3 mode on page 3-41. Note that care must be taken in this mode to ensure that the signal source's (or UUT's) output power is completely settled before giving the TTL trigger.

For full TTL handshaking with buffered measurements, see the RFT modifier description under the T3 MODIFIERS section on page 3-41. A typical programming example for the Fast TTL Triggered mode is shown on page 3-47.

Modifiers: Modifiers Common To All Trigger Modes

Modifier Description: This modifier turns on a specified channel in CW power measurement mode.

Modifier Name: **ON,+**

Modifier Syntax: **ON**

Modifier Description: This modifier turns off the specified channel.

Modifier Name: **OFF,-**

Modifier Syntax: **OFF**

Modifier Description: This modifier determines the average factor for the measurement. In T0 mode, averaging works like a continuous filter, with each subsequent reading taken from the end of the filter. To dump the filter and restart averaging, use the RESET or RS modifier. In T1, T2, and T3 modes, each reading is newly averaged n times.

Modifier Name: **AVERAGE, AVG**

Modifier Syntax 1: **AVG** *hs* numerical value

Valid numerical units: 1, 2, 4, 8, 16, 32, 64, 128, 256

Modifier Syntax 2: **AVG** *hs* state

State definition: **ON, +, OFF, -, RESET, RS**

Modifiers: Modifiers Used Only With T0 Mode

Modifier Description: This modifier places the instrument in max hold mode. Every time the analyzer is talk-addressed, the instrument will output the maximum reading seen since the mode was activated.

Modifier name: **MAXH**

Modifier syntax: **MAXH** *hs* state

State definition: **ON, +, OFF, -**

Modifier Description: This modifier places the instrument in min hold mode. Every time the analyzer is talk-addressed, the instrument will output the minimum power reading seen since the mode was activated.

Modifier name: **MINH**

Modifier syntax: **MINH** *hs* state

State definition: **ON, +, OFF, -**

Modifier Description: This modifier places the measurement in relative reading mode. When the command is received by the analyzer, it takes the current power reading and stores it as a reference. Every time the analyzer is talk-addressed, the instrument will output the difference between the current reading and the stored reference reading (in dB).

Modifier name: **REL**

Modifier syntax: **REL** *hs* state

State definition: **ON, +, OFF, -**

Modifier Description: SRQ in T0 mode operates slightly differently than SRQ in T2 mode. In the T0 mode, when the SRQ modifier is sent the analyzer will wait until the number of averages defined for the channel has been completed. The analyzer will then set the event complete bit in the external status register. The service request and external status bits are set in the instrument status byte. The SRQ interrupt line on the GPIB bus is asserted. This should cause an interrupt in the external controller which may be handled by an interrupt service routine.

Modifier name: **SRQ**

Modifiers: Modifiers Used Only With T1 Mode:

NONE: There are no modifiers specific to the T1 mode.

8003 Precision Scalar Analyzer

Modifiers: Modifiers Used Only With T2 Mode

Modifier Description: ITEMS activates buffered readings in T2 mode. A Buffer is memory internal to the analyzer set aside to store readings. The memory is user defined to any length between 1 and 512 readings. In buffered reading mode, the analyzer directs readings to the buffer memory until the buffer is full. When talk-addressed, the analyzer then sends the entire buffer full of readings to the controller. Buffering the data allows the analyzer to measure even faster since it does not have to output the data to the controller between each reading. Once a buffer is specified for one channel, all active channels must use a buffer of the same size. The last ITEMS n command received determines the buffer size for all channels. When n=1 or when ITEMS is not specified, the triggered mode waits to be talk-addressed after each reading. For buffer sizes greater than 1, the analyzer does not wait to be talk-addressed after each trigger, but instead adds the new reading to each active channel's buffer. When the buffer is full, the analyzer halts and waits to be talk-addressed. When talk-addressed, the analyzer sends the buffered readings to the controller. The entire buffer for the lowest channel number is sent first, followed by the buffer for the next highest channel number, and so on, until all buffers are sent. Each individual data item is separated from the next by a comma, and data from the end of one buffer and the beginning of the next is simply separated by a comma.

Modifier name: ITEMS

Modifier syntax: ITEMS *hs* numerical value

Valid numerical values: Any integer between 1 and 512

Modifier Description: SRQ sets up a GPIB handshake for buffered readings in T2 mode. In GPIB-triggered mode, the analyzer ignores extra triggers that may occur while the analyzer is occupied with a reading. When data buffers are used, this may lead to a situation where the controller thinks that the 8003 should be through taking data, while the 8003 is waiting for more triggers. One way around this problem is to ensure that the trigger rate is below the 8003's maximum data rate. Another way is to use the optional SRQ modifier to provide a full GPIB handshake. When the SRQ modifier is added to the **POWER** command, the analyzer will assert the bus SRQ line after it completes each reading. The controller software must then be written to wait for the SRQ interrupt before giving another trigger. Due to the overhead of processing the SRQ interrupt, full handshake operation may be slower than single-ended triggering of the readings.

Modifier name: SRQ

Modifier syntax: SRQ

Modifiers: Modifiers Used Only With T3 Mode

Modifier Description: ITEMS activates buffered readings in T3 mode. A Buffer is memory internal to the analyzer set aside to store readings. The memory is user defined to any length between 1 and 512 readings. In buffered reading mode, the analyzer directs readings to the buffer memory until the buffer is full. When talk-addressed, the analyzer then sends the entire buffer full of readings to the controller. Buffering the data allows the analyzer to measure even faster since it does not have to output the data to the controller between each reading. Once a buffer is specified for one channel, all active channels must use a buffer of the same size. The last ITEMS n command received determines the buffer size for all channels. When n=1 or when ITEMS is not specified, the triggered mode waits to be talk-addressed after each reading. For buffer sizes greater than 1, the analyzer does not wait to be talk-addressed after each trigger, but instead adds the new reading to each active channel's buffer. When the buffer is full, the analyzer halts and waits to be talk-addressed. When talk-addressed, the analyzer sends the buffered readings to the controller. The entire buffer for the lowest channel number is sent first, followed by the buffer for the next highest channel number, and so on, until all buffers are sent. Each individual data item is separated from the next by a comma, and data from the end of one buffer and the beginning of the next is simply separated by a comma.

Modifier name: ITEMS

Modifier syntax: ITEMS *hs* numerical value

Valid numerical values: Any integer between 1 and 512

Modifier Description: The RFT (Ready For Trigger) modifier provides a full hardware handshake for TTL-triggered readings. As with GPIB-triggered readings, the 8003 will ignore extra hardware triggers that occur before it is ready to take another reading. In the TTL-triggered mode, an optional hardware handshake is provided which is analogous to the SRQ handshake used in the GPIB-triggered mode. The hardware handshake mode with data buffers is the analyzer's fastest way to collect data. Single channel reading speeds of greater than 400 readings per second are possible in this mode. To use the hardware handshake, add the RFT modifier to the **POWER** command (this assumes you have already selected T3 mode). The AC MOD OUT connector on the 8003 provides the hardware handshake. If the RFT modifier is given, the 8003 provides a TTL-high at the AC MOD OUT connector until it receives a hardware trigger on its INPUT 1 connector. It then sets AC MOD OUT to TTL-low while it is busy processing the reading. When it has finished the reading, the 8003 toggles the AC MOD OUT connector back to TTL-high. Appropriate circuitry in the test system can decode and use this signal to complete the handshake. There are a couple of timing consider-

8003 Precision Scalar Analyzer

ations that must be observed. First, when the 8003 asserts AC MOD OUT high to indicate Ready for Trigger, the test system must wait for at least 500 μ s before pulling the INPUT 1 trigger line high. Second, the INPUT 1 trigger must be kept high for at least 500 m.

Modifier name: **RFT**

Modifier syntax: **RFT**

Description: The 8003 analyzer offers a very powerful and flexible CW measurement capability over the GPIB bus. Four modes of CW measurements allow 1) slow readings with display updates, 2) fast free-running measurements, 3) fast GPIB-triggered measurements, and 4) fast TTL-triggered measurements. Single channel reading rates in excess of 300 readings per second are achievable in the fast data modes. In addition, the fast GPIB and TTL-triggered modes both allow the optional use of internal data buffers and bus or hardware handshakes to maximize system throughput.

CW power measurements are made over the GPIB bus using the **POWER** command.

See the Fast-CW Mode Programming Example starting on page 3-43.

See the Tri-Triggered Fast-CW Mode Programming Example on page 3-47.

See the Fast Step CW Measurement Mode Programming Example on page 3-48.

Fast-CW Mode Programming Example

```

10  !*****
20  ! PROGRAM TO DEMONSTRATE MEASUREMENT SPEED OF
30  ! GIGA-TRONICS 8003 PRECISION SCALAR ANALYZER RUNNING IN
40  ! fast-cw MODE.
50  ! COPYRIGHT 2001 GIGA-TRONICS INC.
60  !
70  ! This program assumes:
80  ! 1) Analyzer at GPIB address 4
90  ! 2) Sweeper in CW mode and set to desired power level
100 ! 3) Sensor plugged into A input and connected to sweeper output
110 !
120 !*****
130 !
140 OPTION BASE 1! All arrays start at index 1
150 INTEGER Maxcount,Counter
160 !
170 CLEAR 704! Send device clear to preset the analyzer
180 !
190 OUTPUT 704;READOUT! Numeric screen format
200 OUTPUT 704;POWER 1,A! Channel 1 reads sensor A
210 OUTPUT 704;CHAN 1;ON;CHAN 2;OFF;CHAN 3;OFF;CHAN 4;OFF
220 !
230 ! Set up sweeper for measurement
240 ! CW, 2 GHz, RF on, 0 dBm
250 OUTPUT 704;FIXED;FREQ 2000;LEVEL ON;LEVEL 0
260 WAIT 2! Wait for sweeper to set up parameters
270 !
280 !.....
290 ! MEASUREMENT OF FREE RUNNING FAST CW MODE MEASUREMENT SPEED
300 !
310 ! Example of zeroing sensor first (use only for low level msmts)
320 ON INTR 7 GOSUB Zero srq! SRQ service routine
330 Srq flag=0! Clear srq flag
340 ENABLE INTR 7;2! Enable interrupts
350 OUTPUT 704;ZERO A;srq! Zero sensor A, assert SRQ when done
360 WHILE Srq flag=0! Endless loop while waiting for zero
370 END WHILE! (of course, program could be doing
380 ! something else)
390 WAIT 1
400 !
410 OUTPUT 704;POWER 1;T1! Set free running fast cw mode = T1
420 WAIT 1! IMPORTANT** wait for analyzer to change modes and update
430 ! temperature correction
440 !
450 OUTPUT 704;POWER 1;AVG OFF! No averaging for this example
460 !
470 ! Example of updating temp and low level calibration
480 OUTPUT 704;RDTEMP!
490 WAIT 1! Wait to complete command
500 !
510 GOTO Msmt loop! Jump around srq service routine
520 Zero srq: Srq flag=1! srq service routine sets srq flag
530 Status 8003=SPOLL(704)! serial poll clears srq message
540 ENABLE INTR 7;2! re-enable interrupts
550 RETURN
560 !
570 Msmt loop:!
580 ! Initialize loop variables
590 Maxcount=1000! Take 1000 readings
600 Counter=0! Initialize counter
610 !
620 ! MAIN LOOP
630 Starttime=TIMEDATE
640 WHILE Counter<Maxcount

```

8003 Precision Scalar Analyzer

```
650     ENTER 704;Reading! In free running mode, analyzer gives last readin
660     ! any time that it is talk-addressed.
670     Counter=Counter+1
680 END WHILE
690 Tottime=TIMEDATE-Starttime
700 OUTPUT 704;PWR 1;TD! Good housekeeping returns to display update mode
710 WAIT 1! Always wait after mode change
720 !
730 PRINT Free running mode msmts/second = ;Maxcount/Tottime,Power = ;Rea
740 !
750 !.....
760 ! MEASUREMENT OF TRIGGERED FAST CW MODE MEASUREMENT SPEED
770 !
780 OUTPUT 704;PWR 1;T2! First set triggered fast cw mode = T2
790 WAIT 1! IMPORTANT** wait for analyzer to change modes and update
800     ! temperature correction
810 !
820 ! Initialize loop variables
830 Maxcount=1000! Take 1000 readings
840 Counter=0! Initialize counter
850 !
860 ! MAIN LOOP
870 Starttime=TIMEDATE
880 WHILE Counter<Maxcount
890 TRIGGER 704! Triggered mode requires Group Execute Trigger
900 ENTER 704;Reading
910 Counter=Counter+1
920 END WHILE
930 Tottime=TIMEDATE-Starttime
940 !
950 PRINT Triggered mode msmts/second = ;Maxcount/Tottime,Power = ;Readin
960 !
970 OUTPUT 704;PWR 1;TD! Good housekeeping to return analyzer to
980 ! standard cw mode to update display
990 WAIT 1
1000 !
1010 !.....
1020 ! EXAMPLE OF 2 CHANNEL MEASUREMENT IN FAST-TRIGGERED MODE
1030 !
1040 OUTPUT 704;POWER 1;A;ON;POWER 2;A;ON;CHAN 3;OFF;CHAN 4;OFF
1050 ! Note that both channels are reading the same sensor A. This is just
1060 ! for convenience in running a demo. It is just as easy to define
1070 ! channel 2 to read sensor B. With 2 different sensors, the msmt speed
1080 ! is almost identical to the code running here.
1090 !
1100 OUTPUT 704;PWR 1;T2! First set triggered fast cw mode = T2
1110 WAIT 1! IMPORTANT** wait for analyzer to change modes and update
1120 ! temperature correction
1130 !
1140 ! Initialize loop variables
1150 Maxcount=1000! Take 1000 readings
1160 Counter=0! Initialize counter
1170 !
1180 ! MAIN LOOP
1190 Starttime=TIMEDATE
1200 WHILE Counter<Maxcount
1210 TRIGGER 704! Triggered mode requires Group Execute Trigger
1220 ENTER 704;Reading a;Reading b
1230 ! Now, analyzer returns 2 readings for every trigger
1240 Counter=Counter+1
1250 END WHILE
1260 Tottime=TIMEDATE-Starttime
1270 !
1280 PRINT Sensor A = ;Reading a;, Sensor B = ;Reading b
1290 PRINT 2-channel msmt speed = ;Maxcount/Tottime; rdgs/second
```

```

1300 !
1310 OUTPUT 704:PWR 1:T0! Good housekeeping to return analyzer to
1320 ! standard cw mode to update display
1330 WAIT 1
1340 !.....
1350 ! EXAMPLE OF BUFFERED MEASUREMENTS IN FAST-TRIGGERED MODE
1360 !
1370 OUTPUT 704:POWER 1,A:ON:POWER 2,A:ON:CHAN 3:OFF:CHAN 4:OFF
1380 ! Read from 2 channels in this example
1390 !
1400 ! ***** THE ITEMS n COMMAND SETS THE BUFFER SIZE *****
1410 OUTPUT 704:PWR 1:T2:ITEMS 100! Triggered fast cw mode = T2
1420 ! Also, buffer of 100 elements set for each active channel
1430 WAIT 1! IMPORTANT** wait for analyzer to change modes and update
1440 ! temperature correction
1450 !
1460 DIM Buffer a(100), Buffer b(100)
1470 ! MAIN LOOP
1480 FOR Reading=1 TO 100
1490 TRIGGER 704! Triggered mode requires Group Execute Trigger
1500 ! Analyzer automatically buffers one reading per channel for
1510 !   each trigger
1520   WAIT .005! Important to not send new trigger before analyzer is
1530 ! ready to accept it. See T1 mode description
1540 NEXT Reading
1550 !
1560 ! Now read buffers from the analyzer
1570 OUTPUT 704:OUTPUT 1! Tell analyzer to send buffers
1580 ENTER 704:Buffer a(*),Buffer b(*)
1590 !
1600 ! Print buffers
1610 FOR I=1 TO 100
1620   PRINT I; Chan A = ;Buffer a(I); Chan B = ;Buffer b(I)
1630 NEXT I
1640 !
1650 OUTPUT 704:PWR 1:T0! Good housekeeping to return analyzer to
1660 ! standard cw mode to update display
1670 !
1680 !.....
1690 ! EXAMPLE OF BUFFERED MODE WITH FULL GPIB HANDSHAKE
1700 !
1710 OUTPUT 704:POWER 1,A:ON:CH 2:OFF:CH 3:OFF:CH 4:OFF
1720 ! Use only channel 1 for this example
1730 !
1740 ! *** THE SRQ MODIFIER TELLS ANALYZER TO ASSERT SRQ AFTER EVERY READING
1750 ! Use GPIB triggered mode with 100 element buffer
1760 OUTPUT 704:POWER 1:T2:ITEMS 100:SRQ

1770 WAIT 1! IMPORTANT** wait for analyzer to change modes and update
1780 ! temperature correction
1790 !
1800 ! SET UP INTERRUPT SERVICE ROUTINE TO HANDLE SRQ
1810   Srq flag=0! Reset interrupt service routine flag
1820 ON INTR 7 GOSUB Reading srq
1830 ENABLE INTR 7:2
1840 !
1850 ! MAIN LOOP
1860 FOR Reading=1 TO 100
1870 TRIGGER 704! Triggered mode requires Group Execute Trigger
1880 ! Analyzer automatically buffers one reading per channel for
1890 !   each trigger
1900 WHILE Srq flag=0! Infinite loop waits for reading SRQ
1910 END WHILE
1920 NEXT Reading
1930 !

```

8003 Precision Scalar Analyzer

```
1940 ! NOW READ BUFFER FROM ANALYZER
1950 ENTER 704;Buffer a(*)
1960 !
1970 ! Print buffer
1980 FOR I=1 TO 100
1990 PRINT I; Chan A = ;Buffer a(I)
2000 NEXT I
2010 !
2020 OUTPUT 704;PWR 1;TO! Good housekeeping to return analyzer to
2030 ! standard cw mode to update display
2040 STOP
2050 !
2060 ! INTERRUPT SERVICE ROUTINE FOR READING SRQ
2070 Reading srq:~
2080   Srq flag=1! Set SRQ flag
2090   Status=SPOLL(704)! Serial poll clears srq
2100   ENABLE INTR 7;2! Re-enable interrupts
2110 RETURN
2120 END
```

TTL-Triggered Fast-CW Measurement Programming Example

```

10  !*****
20  ! PROGRAM TO DEMONSTRATE AN APPLICATION OF TTL-TRIGGERED
30  ! FAST CW MEASUREMENTS
40  !
50  ! COPYRIGHT 2001 GIGA-TRONICS INC.
60  !
70  ! This program assumes:
80  ! 1) Analyzer at GPIB address 4
90  ! 2) Gigatronics 7200 Sweeper on the system bus at GPIB address 20
100 ! 3) Sensors plugged into A and B channel inputs
110 !
120 !*****
130 !
140 OPTION BASE 1
150 DIM Buffer a(101),Buffer b(101)
160 !
170 ! FIRST CONFIGURE THE ANALYZER
180 CLEAR 704! Send device clear to preset the analyzer
190 OUTPUT 704;READOUT! Numeric screen format
200 OUTPUT 704;POWER 1;A;POWER 2;C;CHAN 3;OFF;CHAN 4;OFF
210 ! Channel 1 reads incident power, chan 2 reads output power
220 !
230 ! SET UP GIGATRONICS 7200 SIGNAL GENERATOR IN DIGITAL STEP SWEEP MODE
240 OUTPUT 720;GA2GZ! Start frequency of 2 GHz
250 OUTPUT 720;GB20GZ! Stop frequency of 20 GHz
260 OUTPUT 720;GC100MZ! Step frequency of 100 MHz
270 OUTPUT 720;GD10MS! Step dwell time of 10 ms
280 OUTPUT 720;PL0DB! Output power level of 0 dBm
290 OUTPUT 720;RF1! Turn the RF on
300 WAIT 3! Wait for the sig gen to set up parameters
310 !
320 !.....
330 ! MEASUREMENT OF INCIDENT AND OUTPUT POWER DURING DIGITAL STEP SWEEP
340 ! USING TTL TRIGGER TO MAKE 8003 POWER READINGS
350 !
360 OUTPUT 704;PWR 1;T3;ITEMS 101
370 WAIT 1! IMPORTANT to allow analyzer to process trigger mode change
380 ! TTL trigger mode with 501 item buffer on channels 1 and 2
390 ! Analyzer is now armed and ready. Any TTL triggers received
400 ! will trigger a reading on each channel and stuff in buffer
410 !
420 OUTPUT 720;D2! Now, trigger synthesizer to take a single sweep
430 WAIT 10! Wait for step sweep to finish
440 !
450 OUTPUT 704;OUTPUT 1! Tell analyzer to output data
460 ENTER 704;Buffer a(*),Buffer b(*)
470 ! Analyzer outputs channel A buffer first, then chan B buffer
480 PRINT Buffer a(*);
490 PRINT Buffer b(*);
500 !
510 OUTPUT 704;POWER 1;TD! Good housekeeping to return analyzer
520 ! to display update mode
530 WAIT 1
540 END

```

8003 Precision Scalar Analyzer

Fast Step CW Measurement Mode Programming Example

```
10 !*****
20 ! PROGRAM TO DEMONSTRATE FAST CW MEASUREMENTS USING
30 ! GIGA-TRONICS 8003 PRECISION SCALAR ANALYZER RUNNING IN
40 ! fast-cw MODE
50 ! COPYRIGHT 2001 GIGA-TRONICS INC.
60 !
70 ! The program assumes:
80 ! 1) Analyzer at GPIB address 4
90 ! 2) Sweeper connected to 8003 private bus
100 ! 3) Sweeper capable of 8-12 GHz freq range and +10 dBm output
110 ! 4) Sensor connected to 8003 channel A input and sweeper output
120 !*****
130 !
140 CLEAR 704! Send device clear to preset the analyzer
150 !
160 OUTPUT 704;CHAN 1;ON;CHAN 2;OFF;CHAN 3;OFF;CHAN 4;OFF
170 OUTPUT 704;READOUT! Numeric screen format
180 !
190 ! Set up sweeper for stepped-CW operation at +10 dBm
200 OUTPUT 704;FIXED;FREQ 8000;LEVEL ON;LEVEL 10
210 WAIT 2
220 !
230 ! This next command puts the analyzer in power meter mode, displaying
240 ! power from sensor A on channel 1.
250 OUTPUT 704;PWR 1;A;AVG OFF
260 WAIT 2! Not necessary, but allows number on display
270 !
280 OUTPUT 704;PWR 1;T2! First set triggered fast cw mode = T2
290 WAIT 1! IMPORTANT** wait for analyzer to change modes and update
300 ! temperature correction
310 !
320 ! MAIN ROUTINE
330 ! Steps sweeper from 8 to 12 GHz in 100 MHz steps and measures power
340 !
350 FOR I=8000 TO 12000 STEP 100
360     OUTPUT 704;FIXED;FREQ ;I! Change sweeper frequency
370     WAIT .4! User adjust for sweeper settling time
380     TRIGGER 704! Trigger 8003 to make fast cw measurement
390     ENTER 704;Reading! Read power
400     PRINT I;Reading
410 NEXT I
420 !
430 OUTPUT 704;PWR 1;T0! Good housekeeping to return to standard
440 ! cw measurement mode so that display updates
450 END
```

3.3.22 Temperature & Low Level Offset Update Structure

RDTEMP

Syntax: **RDTEMP** *hs* sensor specifier

Specifiers: **A, B, or C**

Output format for temperature:

dd.d

Assumed units:

degrees C

Description: In the fast CW measurement modes (trigger modes T1 through T3 of the POWER command), temperature and low level correction are turned off to maximize the measurement speed. At most power levels (>-50 dBm), this causes negligible reading error. At very low power levels, the RDTEMP command should be used before each fast measurement run to update temperature and low level offset drift.

If the analyzer is listen addressed immediately after the RDTEMP command, it will also output the temperature in degrees Celsius for the sensor.

3.3.23 Print Definition Command Structure

PRINT

Syntax: **PRINT** *us* modifier **EOL**

Examples: **PRINT;paint;SRQ**

PRINT;laser'SRQ

Modifiers: This modifier defines the type of printer to be receiving the raster scan plot as an HP INK JET PRINTER.

Modifier name: **INK**

Modifier Syntax: **INK**

Modifier Description: This modifier defines the type of printer to be receiving the raster scan plot as an HP PAINT JET PRINTER.

Modifier name: **PAINT**

Modifier Syntax: **PAINT**

Modifier Description: This modifier defines the type of printer to be receiving the raster scan plot as an HP LASER JET+ PRINTER.

Modifier name: **LASER**

Modifier Syntax: **LASER**

Modifier Description: Asserts GPIB SRQ at the end of a print routine. The system controller would normally use an interrupt service routine to take action once the analyzer asserts SRQ. An SRQ can be cleared by doing a GPIB serial poll of the analyzer.

8003 Precision Scalar Analyzer

Description: This verb drives an external Ink Jet or Paint Jet printer through the analyzer's private GPIB bus (or Laser Jet printer connected to the analyzer's RS-232 bus). The 8003 does a screen dump to the printer in the raster scan mode - capturing everything currently on the screen. Because the print takes a considerable (and variable) amount of time to execute, it is highly recommended to use the SRQ modifier to tell the controller when the print is finished.

3.3.24 Readout Display Definition Command Structure

READOUT, TEXT, TXT

Syntax: **TXT**

Example: **READOUT**

Related Command:

POWER

Description: This verb places the 8003 display in the readout (non-graph) mode. There are no channel or sensor specifiers and no modifiers.

3.3.25 Sensor Definition Command Structure

SENSOR, SEN

Syntax: **SEN** *hs* Sensor Specifier [*us* modifier]..[*us* modifier]

Specifiers: **A, B, and C**

Modifiers: This Modifier defines an offset in dBs for the sensor.

Modifier name: **OFFSET, OS, ATTN**

Modifier Syntax: **OS** *ds* numerical value

numerical value range: -90.00 to +90.00

numerical resolution: 0.01

assumed units: dB

Modifier Description: This modifier defines the detection mode as AC detection for the sensor specified.

Modifier name: **AC**

Modifier Syntax: **AC**

Modifier Description: This modifier defines the detection mode as DC detection for the sensor specified

Modifier name: **DC**

Modifier Syntax: **DC**

Description: There are two separate formats that use the SWP verb. One form (described above) defines a current Swept power measurement mode and attributes for a channel. The second form (described starting on page 3-60) measures TRACE, PATHCAL, and CALFACTOR data that will be stored to be used with future measurements.

Modifiers Specific to 8034XA Series Peak Sensors Only

The 8034XA Series Peak Sensors allow measurement of pulsed RF signals. Unlike the standard CW sensors, the Peak Sensors require a trigger signal. The Peak Sensors capture the instantaneous power at the moment of the trigger and hold the value until the next trigger. The Peak Sensors offer three different trigger modes - one internal free-running trigger mode, and two external trigger modes. The following modifiers choose between the three trigger modes. For Section 3.3.25, the examples have been provided after their modifier unlike the previous sections, due to numerous modifiers for the 8034XA.

Examples: **SEN R A;ac;attn -10.5;SEN B;dc;SEN C;dc**

SENSOR A;FREERUN

SEN B;dlytrig

Modifier Description: The **FREERUN** modifier puts the Peak Sensor in free running trigger mode. This mode is primarily intended for measuring CW signals (where no external trigger is available) with the Peak Sensor. Triggers are internally generated at approximately 1 kHz rate.

8003 Precision Scalar Analyzer

Modifier Name: **FREERUN**

Modifier Syntax: **FREERUN**

Modifier Description: The **TRIG** modifier puts the Peak Sensor in trigger immediate mode. In this mode, when a TTL transition from low to high occurs at the trigger input connector on the sensor, the Peak Sensor captures and holds the instantaneous peak power. The internal delay from TTL trigger to actual power capture is nominally 250 ns. The user is expected to externally synchronize the trigger to read at the desired point in the pulse.

Modifier Name: **TRIG**

Modifier Syntax: **TRIG**

Modifier Description: The **DLYTRIG** modifier puts the Peak Sensor in delayed trigger mode. This mode is similar to the one above except that a fixed delay is added after the trigger, before the sensor reads the RF pulse power. This delay is factory set (or can be adjusted by changing a potentiometer setting on the Peak Sensor circuit board). It's nominal value is 500 ns and can be manually adjusted from 500 ns to 3 m.

Modifier Name: **DLYTRIG**

Modifier Syntax: **DLYTRIG**

Description: This verb ascribes attributes to a sensor. Such features as AC or DC detection and offsets are attributed to a given sensor by a command string beginning with this verb.

3.3.26 Sensor Short/Open Calibration Command Structure

SHORT

Syntax: **SHORT** *hs* Sensor Specifier *us* [modifier 1] **EOL** modifier 2 **EOL**

Example: **SHORT A;srq EOL OPEN EOL**

Sensor Specifiers: **A, B, or C**

Modifiers: This modifier requests that a service request be sent upon completion of the Sensor short calibration. **When the short calibration is complete the OPEN CALIBRATION modifier MUST be sent.**

Modifiers name: **FB, NB**

Modifier Syntax 1: **Full Band, Narrow Band**

Modifier name: **SRQ**

Modifier Syntax 2: **SRQ**

If the SRQ modifier is received the 8003 will initiate the SHORT CALIBRATION upon the specified Sensor. When completed, the event complete bit will be set in the external status register and the service request and the external status bits will be set in the instrument status byte.

Modifier Description: This modifier initiates the second part of the SHORT/OPEN CALIBRATION.

Modifier name: **OPEN**

Modifier Syntax: **OPEN EOL**

Description: This verb defines and initiate a Sensor Short/Open Calibration. This is a very special operation. The Frequency Response Correction Using Path Calibration discussion starting on section 2.8.2.2 of the OPERATION chapter should be consulted for a complete description. It should be noted that after the short calibration is completed the 8003 expects an OPEN verb to be sent so that the calibration can be completed.

3.3.27 Swept Measurement Command Structure

SWP, SWP?

Current Swept Measurements:

Swept power measurements are defined by a command string beginning with SWP. The addition of the question mark affixed to the end of the SWP verb is a query flag. This is used if the Swept data measured on the specified channel is to be captured and returned to the host controller when the instrument is next talked addressed. The return value is defined as follows:

```
data(freq 1),data(freq 2),.....,data(freq n)EOL
```

where:

freq 1 = start frequency

freq n = stop frequency

freq 2 = $\text{freq 1} + 2 * (\text{freq 2} - \text{freq 1}) / (\text{items} - 1)$

items = an integer from 1 to 512 defined by the ITEMS modifier.

where a data item, data(freq x), is returned in the fixed form of ±ddd.dd. The assumed units for the data items is dBm if in absolute measurement mode or dB if in relative measurement mode. The data returned represents the next full sweep (or n full sweeps if an averaging factor of n is chosen). The Output command can capture and return data (see the related verb OUTPUT section 3.3.19 for more information.) If the channel is making a CW measurement and the data returned represents the measured data point, the format is dataEOL.

Current Swept Measurement Syntax:

```
SWP[?] hs Channel Specifier [ds Sensor Specifier] us [modifiers]..[modifiers]
```

Current Swept Measurement Specifiers:

Channel specifiers: **1, 2, 3, and 4**

Sensor Specifiers: **A, B, C, A/B, A/C, B/A, B/C, C/A, and C/B**

Current Swept Measurement Modifiers:

Modifier Description: This modifier defines an average factor for the measurement.

Modifier name: **AVERAGE, AVG**

Modifier Syntax 1: **AVG ds** numerical value or state

valid numerical values: 1, 2, 4, 8, 16, 32, 64, 128, 256

assumed units: no units

Modifier Syntax 2: **AVG hs** state

State definition: **ON, +, OFF, -, RESET, RS**

Modifier Description: This modifier defines the measurement to be made in absolute power (dBm) units with the appropriate Cal Factors applied.

If a non-valid numerical value is used, the valid value closest to the entered value is used.

Modifier name:	MEAS, M, ABS
Modifier Syntax:	MEAS
Modifier Description:	This modifier defines the measurement to be made in relative units (meas data - path cal).
Modifier name:	NORM, N, -PC
Modifier Syntax:	NORM
Modifier Description:	This modifier sets the scale factor used for the CRT graphical swept data display.
Modifier name:	SCALE, SC
Modifier Syntax 1:	SC <i>ds</i> state
State definition:	+CA = continuous auto scale on -CA = continuous auto scale off AUTO = auto scale ONCE
Modifier Syntax 2:	SC <i>ds</i> numerical value
valid numerical values:	0.1, 0.2, .05, 1.0, 2.0, 5.0, 10, 20
Modifier Description:	This modifier defines the reference position for the measured trace for the 8003 CRT graphic display.
Modifier name:	REF_POS, RP
Modifier Syntax:	RP <i>ds</i> numerical value
valid numerical value:	-4 = bottom of screen -3 = next graticule up -2 = next graticule up -1 = next graticule up 0 = center graticule +1 = next graticule up +2 = next graticule up +3 = next graticule up +4 = top of screen

All other non-valid numerical values force the setting to center screen.

8003 Precision Scalar Analyzer

Modifier Description: This modifier sets the value of the reference level

Modifier name: **REF_LEV, RL**

Modifier Syntax: **RL** *ds* numerical value

numerical value range: -90 to +90

assumed units: dBm or db

Modifier Description: This modifier turns on a specified channel which is to make the swept measurement.

Modifier name: **ON, +**

Modifier Syntax: **ON**

Modifier Description: This modifier turns off a specified channel which is to make the SWEPT measurement.

Modifier name: **OFF, -**

Modifier Syntax: **OFF**

Modifier Description: This modifier is to request that a service request be sent upon completion of the SWEPT measurement defined for this channel.

Modifier name: **SRQ**

Modifier Syntax: **SRQ**

Once the SRQ modifier is received, the 8003 will make the measurement specified for this channel. If the number of averages defined for this channel has been satisfied, the event complete bit is set in the external status register and the service request and the external status bits are set in the instrument status byte.

 **NOTE:** This SRQ is used with Query Flag only.

Modifier Description: This modifier defines the number of data items to be returned when the measured data is requested for output to the host computer.

Modifier name: **ITEMS**

Modifier Syntax: **ITEMS** *ds* numerical value

valid numerical values: 1 to 512

assumed units: no units

Modifier Description: The following modifiers define and control the markers on the trace. As from the front panel, 10 markers (numbered 0 through 9) can be defined. A marker must be defined (its frequency set) before it can be used. Once a marker is defined for any channel, it will appear on all active channels at the defined frequency.

Modifier name:	MARKER
Modifier Syntax:	MARKER <i>hs</i> numerical value [<i>us</i> state]
valid numerical values:	0 through 9, all
assumed units:	no units (these are marker numbers)
State Syntax:	ON, OFF, CLEAR (turns marker on, off, or clears marker)
Modifier name:	DEF_MKR
Modifier Syntax:	DEF_MKR <i>hs</i> numerical value [<i>us</i> frequency f]
valid numerical values:	0 through 9
assumed units:	no units
Frequency Syntax 1:	FREQ <i>hs</i> frequency (User defined marker frequency)
valid frequency values:	0 to 99999
assumed units:	MHz
Frequency Syntax 2:	CURSFREQ (Assigns the current cursor frequency to the marker)
Modifier Examples:	SWP 1;DEF_MKR 2;FREQ 3500 Defines Marker 2 on channel 1 at frequency 3500 MHz SWP 4;DEF_MKR 9;CURSFREQ Defines Marker 9 on channel 4 at the current cursor frequency SWP 2;MARKER 3;ON Turn on Marker 3 SWP 1;MARKER ALL;OFF Turn off all markers SWP 3;MARKER 8;CLEAR Clear marker 8 (turn off and clear frequency assignment)
Modifier Description:	These modifiers are used to perform an OPEN/SHORT bridge calibration with trace memories instead of path cal memories. The operator should connect a SHORT to the bridge before the system executes the STORE_SHORT modifier. The operator should then connect the OPEN to the bridge and the system should execute only the STORE_OPEN modifier by itself. The SRQ service request is optionally used to tell the controller when the analyzer has finished each operation. Do not send the verb SWP n; before the STORE_OPEN modifier (see examples next page).

8003 Precision Scalar Analyzer

Modifier name:	STORE_SHORT
Modifier Syntax:	STORE_SHORT <i>hs</i> numerical value [<i>us</i> SRQ]
valid numerical values:	0 through 9
assumed units:	no units (these are trace memory numbers)
Modifier name:	STORE_OPEN
Modifier Syntax:	STORE_OPEN [<i>us</i> SRQ]
Modifier Examples:	SWP 2;STORE_SHORT 8;SRQ Take the current trace on channel 2 and store it in trace memory 8. Assert SRQ when done. STORE_OPEN;SRQ This should be sent to the analyzer as a string just by itself once the operator has connected the OPEN to the bridge. The analyzer then takes the current trace, averages it with the previously stored trace, and stores it in trace memory 8. Asserts SRQ when done.
Modifier Description:	The SMOOTH modifier activates the trace smoothing function.
Modifier name:	SMOOTH
Modifier Syntax:	SMOOTH <i>hs</i> numerical value or state
valid numerical values:	0.1 to 20.0
assumed units:	percent of trace, resolution in tenths
state definition:	ON, OFF
Modifier Example:	SWP 3;SMOOTH 0.5;SMOOTH ON Defines smoothing at 0.5% of full trace, turns smoothing on
Modifier Description:	The LIMIT modifier allows GPIB definition of limit lines. Limit lines are defined for each channel. Each limit line consists of a point, a flat line segment, a sloped line segment or multiple combinations of the three. The LIMIT modifier has two syntaxes. The first turns entire limit lines on or off. The second defines limit lines. See page 2-31 of the DISPLAY key discussion in the Front Panel Functional Description section for a more detailed description of limit lines.



NOTE: Please see the **LIMIT** modifier of the **OUTPUT** command at the top of page 3-31 for a description of reading PASS/FAIL indications from limit lines.

Modifier name:	LIMIT
Modifier Syntax 1:	LIMIT <i>hs</i> state
state definition:	ON, OFF turns off entire limit line for the specified channel.
Modifier Syntax 2:	LIMIT <i>hs</i> numerical value or ALL modifier
valid numerical values:	1 to 12 corresponding to segment numbers
Limit Modifier 1:	CLEAR clears segment n (or all) for active channel's limit lines
Modifier Syntax:	CLEAR
Limit Modifier 2:	POINT defines a point limit
Modifier Syntax:	POINT <i>hs f1 ds p1 ds p2</i>
Argument syntax:	see Limit Modifier 4, below
Limit Modifier 3:	FLAT defines a flat line segment limit
Modifier Syntax:	FLAT <i>hs f1 ds p ds p2 ds f2</i>
Argument syntax:	see Limit Modifier 4, below
Limit Modifier 4:	SLOPE defines a sloping line segment limit
Modifier Syntax:	SLOPE <i>hs f1 ds p1 ds p2 ds f2 ds p3 ds p4</i>
Argument syntax:	f1 starting frequency in MHz p1 upper limit in dB (starting limit) p2 lower limit in dB (starting limit) f2 ending frequency in MHz p3 ending upper limit in dB p4 ending lower limit in dB
Modifier Examples:	<p>SWP 1;LIMIT 1;POINT 2500,10.5,9.5 Defines a point limit line for channel 1 at 2500 MHz with 10.5 dB upper limit, and 9.5 dB lower limit</p> <p>SWP 1;LIMIT ON Turns on limit line defined above.</p> <p>SWP 3;LIMIT 3;SLOPE 8000,0,-5,12000,5,-10 Defines a slope limit segment (third segment of the limit line) for channel 3. Line is defined from 8 GHz to 12 GHz. Upper segment goes from 0 dB at 8 GHz to 5 dB at 12 GHz. Lower segment goes from -5 to -10 dB.</p> <p>SWP 3;LIMIT 3;CLEAR Clears third segment of limit line on channel 3.</p>

8003 Precision Scalar Analyzer

Current Swept Measurement Example:

SWP? 3;abs;avg 16;srq;items 200

Current Swept Measurement Related Commands:

**OUTPUT
GRAPH
SWPF
SWPS**

Swept Measurements To Be Stored:

The second trace form of the **SWP** command stores, displays, or clears TRACE data.

Stored Swept Measurement Syntax:

SWP *hs* Channel Specifier *us* Memory Trace Specifier *ds*

Stored Swept Measurement Syntax:

SWP *hs* Channel Specifier *us* Memory Trace Specifier *ds*

Stored Swept Measurement Specifiers:

Trace specifiers:	TRACE n, -TRACE n, STORE_TRC n, CLEAR_TRC n
valid n values:	0 through 9 (ALL is valid for CLEAR_TRC)
TRACE n:	Programs the specified channel to display memorized Trace n.
-TRACE n:	Programs the specified channel to be ratio'ed with Trace n.

 **NOTE:** To deactivate ratioing with a trace, use the MEAS modifier. See MEAS modifier description on page 3-55 and the Trace Memory Programming example on page 3-61.

STORE_TRC n:	Stores a swept measurement to memorized Trace n.
CLEAR_TRC n:	Clears a single measurement of all memorized traces.

Stored Swept Measurement Examples:

SWP 1;TRACE 4:
(makes channel 1 display memorized trace 4)

SWP 3;-TRACE 7:
(makes channel 3's measurement a ratio of sensor A to trace 7)

SWP 4;STORE_TRC 8:
(stores the swept measurement being made by channel 4 into trace memory number 8)

SWP 2; CLEAR_TRC ALL:
(clears all stored traces)

Stored Swept Measurement Related Commands

**INPUT
OUTPUT**

Trace Memory Programming Example

```

10 ! *****
20 ! PROGRAMMING EXAMPLE FOR TRACE MEMORY MANIPULATION
30 ! *****
40 !
50 OPTION BASE 1! All arrays start with index of 1
60 DIM Trace data(512)
70 !
80 ! First configure 8003 Analyzer
90 CLEAR 704! Device clear presets 8003
100 OUTPUT 704;SWP 1;A:on! Channel one displays sensor A power
110 OUTPUT 704;CHAN 2;off;CHAN 3;off;CHAN 4;off! turn off unused channels
120 !
130 ! Next configure the sweeper
140 OUTPUT 704;SWPF;start 8000;stop 12000;swpt 1000;level 0;level on
150 ! sweep from 8 GHz to 12 GHz, with 1 second sweep time, at 0 dBm
160 WAIT 5! Wait for sweeper to execute commands
170 !
180 ! Now scale analyzer for easy display
190 OUTPUT 704;SWP 1;scale .5;ref lev 0
200 !
210 ! =====
220 ! Trace memory examples
230 !
240 ! First store channel 1 trace into trace memory 1
250 OUTPUT 704;SWP 1;store trc 1
260 !
270 ! Next subtract trace 1 from currently displayed trace (normalize)
280 OUTPUT 704;SWP 1;-trace 1
290 !
300 ! Display stored trace on channel 2
310 OUTPUT 704;SWP 2;A:on;trace 1
320 ! and scale channel 2
330 OUTPUT 704;SWP 2;scale .5;ref lev 0
340 WAIT 1! wait for analyzer to finish processing display
350 !
360 ! Now read trace into controller
370 OUTPUT 704;OUTPUT;trace 1
380 ENTER 704;Start freq;Stop freq;Trace data(*)
390 ! Note: output format is always start freq (MHz), stop freq (MHz), then
400 ! 512 data points of trace data in dB
410 !
420 ! Invert trace data as an example of user-manipulated trace data
430 MAT Trace data= (0)-Trace data
440 !
450 ! Now read trace back to different trace memory in analyzer
460 OUTPUT 704;INPUT;trace 2;Start freq;Stop freq;Trace data(*)
470 ! Note: input format follows above output format
480 !
490 ! And display user-manipulated trace on channel 3
500 OUTPUT 704;SWP 3;A:on;trace 2
510 ! and scale display
520 OUTPUT 704;SWP 3;scale .5;ref lev 0
530 !
540 ! To return channel 1 to measurement mode without trace memory
550 OUTPUT 704;SWP 1;meas
560 !
570 ! DEMONSTRATION OF OPEN/SHORT BRIDGE CALIBRATION USING TRACE MEMORIES
580 !
590 ! We will use SRQ interrupt to tell controller when calibration step
600 ! is done
610 Srq flag=0! Clear flag to indicate no SRQ received yet
620 ON INTR ? GOSUB Trace srq
630 ENABLE INTR 7;2! Enable interrupts

```

8003 Precision Scalar Analyzer

```
640 !
650 OUTPUT 704;SWP 4;Aion! Use channel 4 for open/short demo
660 WAIT 4! Wait until channel 4 trace is updated
670 !
680 BEEP
690 INPUT Connect SHORT to bridge, press RETURN ... ;Key#
700 OUTPUT 704;SWP 4;store short 3;SR0
710 WHILE Srq flag=0! infinite loop waits for srq from analyzer
720 END WHILE
730 !
740 Srq flag=0
750 BEEP
760 INPUT Connect OPEN to bridge, press RETURN ... ;Key#
770 OUTPUT 704;store open;SR0
780 WHILE Srq flag=0
790 END WHILE
800 !
810 STOP
820 !
830 ! SR0 interrupt service routine
840 Trace srq;!
850 Srq flag=1! Set srq flag to indicate srq received
860 Status1=SPOLL(704)! Serial poll clears srq
870 ENABLE INTR 7;2! Re-enable interrupts
880 RETURN
890 END
```

Limit Line Programming Example

```

10 !*****
20 ! DEMONSTRATION OF LIMIT LINE PROGRAMMING
30 !*****
40 CLEAR 704 ! Device clear presets analyzer
50 !
60 ! First configure analyzer and sweeper
70 OUTPUT 704;SWP 1;A:on;CH 2;off;CH 3;off;CH 4;off
80 ! channel 1 on, all other channels off
90 OUTPUT 704;SWPF;start 2000;stop 4000;level 0;level on
100 ! Sweep from 2 to 4 GHz at 0 dBm
110 OUTPUT 704;SWP 1;scale 1;rp 0;r1 0! Manually scale channel 1
120 WAIT 4! Wait for sweeper to settle and make full trace update
130 !
140 !=====
150 ! Limit line demonstration
160 OUTPUT 704;SWP 1;limit all;clear! clear previous limit lines
170 !
180 ! Set 3 segments, a slope segment, point segment, and flat segment
190 OUTPUT 704;SWP 1;limit 1;slope 2000,4,-4,3000,2,-2
200 OUTPUT 704;SWP 1;limit 2;point 3200,1,-1
210 OUTPUT 704;SWP 1;limit 3;flat 3400,2,-2,4000
220 !
230 ! Now, turn limit line on
240 OUTPUT 704;SWP 1;limit on
250 !
260 ! Read pass or fail status of limit line test
270 ! Analyzer returns string PASS or FAIL as result of test
280 OUTPUT 704;OUTPUT 1;limit
290 ENTER 704;Pass fail#
300 PRINT Limit line status = ;Pass fail#
310 END
    
```

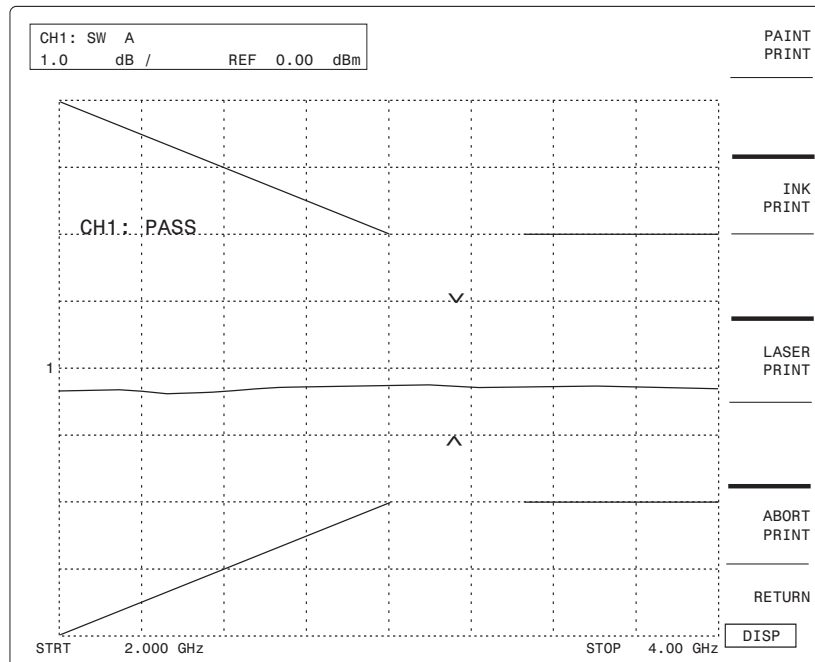

Figure 3-5: Limit Line Display Example

3.3.28 Start/Stop Swept Frequency Source Mode Def. Cmd. Structure

SWPF

Syntax: **SWPF *us* [*us modifier*].[*us modifier*]**

Modifiers: This modifier defines a start frequency for the start/stop swept frequency mode of signal source. The query flag ('?') affixed to the start frequency modifier queries the value of the start frequency. If set, the next time the 8003 is talk-addressed it will output the value of the start frequency in MHZ. The format of the returned data is D.dddddd, where D is zero to 6 digits and the assumed units are MHZ

Modifier name: **START, START?, FA, FA?**

Modifier Syntax: **FA[?] [*ds* numerical value]**

numerical value range: Dependent upon the signal source if the source is supported on the 8003's private bus. If not supported then the range is 1 MHZ to 99 GHZ

Modifier Description: This modifier defines a stop frequency for the start/stop swept frequency mode of signal source. The query flag ('?') affixed to the stop frequency modifier queries the value of the stop frequency. If set, the next time the 8003 is talk-addressed it will output the value of the stop frequency in MHz. The format of the returned data is D.dddddd, where D is zero to 6 digits and the assumed units are MHZ

Modifier name: **STOP, STOP?, FB, FB?**

Modifier Syntax: **FB[?] [*hs* numerical value]**

numerical value range: Dependent upon the signal source if the source is supported upon the 8003 private bus. If not supported then the range is 1 MHZ to 99 GHZ

Description: This modifier defines a POWER LEVEL for the start/stop swept frequency mode of signal source. The query flag ('?') affixed to the power level modifier queries the value of the power level. If set, the next time the 8003 is talk-addressed it will output the value of the power level in dBm. The resolution is 0.01 dBm. The format of the returned data is $\pm D.dd$, where D is zero to three digits and the assumed units are dBm

Modifier name: **LEVEL, LEVEL?, PL, PL?**

Modifier Syntax 1: **PL[?] [*hs* numerical value]**

numerical value range: Dependent upon the signal source if the source is supported on the 8003's private bus. If not supported then the range is -99 to +99 dBm.

Modifier Syntax 2: **PL *hs* on**

State definition: **OFF, ON**

Modifier Description: This modifier defines a SWEEP TIME for the start/stop swept frequency mode of signal source. The query flag ('?') affixed to the sweep time modifier queries the value of the sweep time. If set, the next time the 8003 is talk-addressed it will output the value of the sweep time in ms. The resolution is 1 ms. The format of the returned data is D, where D is two to five digits.

Modifier name: **SWPT, SWPT?, ST, ST?**

Modifier Syntax: **PL[?]** [*ds* numerical value]

numerical value range: Dependent upon the signal source if the source is supported on the 8003's private bus. If not supported then the range is 99000 to 40 ms.

Modifier Description: The update modifier decouples analyzer frequency updates from sweeper frequency updates. This is most commonly used when the analyzer and sweeper are set to different frequencies, as in mixer or frequency multiplier measurements. The analyzer normally uses frequency information to change the operating frequencies of the sweeper, annotate x-axis of the swept display, apply correct Cal Factors to the reading, take the correct portions of trace memories and path cal memories, and fix cursors and markers. The update modifier allows independent control of the sweeper frequencies and all other frequency related analyzer functions. If the modifier UPD ON is included once with the SWPF, SWPS, or FIXED verbs, then all subsequent uses of those verbs will update the sweeper frequency along with the analyzer frequency. If the modifier UPD OFF is included once with the above verbs, then all subsequent uses of those verbs will change only analyzer frequency parameters.

Modifier name: **UPD**

Modifier syntax: **UPD** *hs* state

State definition: **ON, OFF**

Modifier Examples: Send the following commands to modify both sweeper and analyzer frequencies to 2000 to 4000 MHz.

SWPF;fa 2000;fb 10000;pl -10;st 500
SWPF;UPD ON
SWPF;START 2000;STOP 4000

Send the following commands to modify only the analyzer frequency to 6000 to 8000 MHz

SWPF;UPD OFF
SWPF;START 6000;STOP 8000

Related Command:

SWP

Description: This verb places the signal source mode to start/stop swept frequency. This is an instrument wide command and, as such, has no channel or sensor specifiers. However there are many parameters associated with the source mode. These are defined by the modifiers which follow the verb.

8003 Precision Scalar Analyzer

Update Command Programming Example

```
10  !*****
20  ! DEMONSTRATION OF UPDate COMMAND:
110 !*****
120 !
130 CLEAR 704 ! device clear presets analyzer
140 WAIT 4
150 !
151 ! First, configure analyzer to display channel 1 only
160 OUTPUT 704;SWP 1, A;on;SWP 2,A;off;CHAN 3;off;CHAN 4;off
170 OUTPUT 704;SWP 1;scale .2;ref lev 10! manually scale display
200 WAIT 1
840 !.....
850 ! Demonstration of UPDATE command
880 ! First send new setup to both analyzer and sweeper
890 OUTPUT 704;SWPF;UPD ON! Tells analyzer to update both sweeper
891 ! settings and analyzer displays
892 ! Set sweeper and analyzer to 2 to 4 GHz frequency sweep at +10 dBm
900 OUTPUT 704;SWPF;start 2000;stop 4000;level 10;level on
910 WAIT 2! wait for sweeper to update sweep
940 !
941 BEEP
942 INPUT Press RETURN to set analyzer at different frequency ... ,Key#
950 ! Now send analyzer to different start and stop frequency
960 OUTPUT 704;SWPF;UPD OFF! Do not update sweeper, update analyzer
961 ! frequency display only
970 OUTPUT 704;SWPF;start 6000;stop 8000
980 !
990 ! NOTE that the display changes slightly to reflect the new Cal Factors
1000 ! applied at the second set of frequencies
1360 END
```

3.3.29 Span Swept Frequency Source Mode Def. Cmd. Structure

SWPS

Syntax: **SWPS [us modifier]...[us modifier]**

Examples: (See page 3-66 in the SWPF command description for a complete programming example of the UPD modifier.)

Send the following commands to modify both sweeper and analyzer frequencies to 2000 to 4000 MHz.

**SWPS;cf 15000;st 1000;span 500;pl 15.5
SWP;UPD ON
SWPF;START 2000;STOP 4000**

Send the following commands to modify only the analyzer frequency to 6000 to 8000 MHz

**SWPF;UPD OFF
SWPF;START 6000;STOP 8000**

Related Command:

SWP

Modifiers: This modifier defines a center frequency for the center/span swept frequency mode of signal source. The query flag ("?") affixed to the center frequency modifier queries the value of the center frequency. If set, the next time the 8003 is talk-addressed it will output the value of the center frequency in MHZ. The format of the returned data is D.dddddd, where D is zero to 6 digits and the assumed units are MHZ.

Modifier name: **CF, CF?**

Modifier Syntax: **CF[?] [hs numerical value]**

numerical value range: Dependent upon the signal source if the source is supported on the 8003's private bus. If not supported then the range is 1 MHZ to 99 GHZ

Modifier Description: This modifier defines a span frequency for the center/span swept frequency mode of signal source. The query flag ("?") affixed to the span frequency modifier queries the value of the span frequency. If set, the next time the 8003 is talk-addressed it will output the value of the span frequency in MHZ. The format of the returned data is D.dddddd, where D is zero to 6 digits and the assumed units are MHZ.

Modifier name: **SPAN, SPAN?**

Modifier Syntax: **SPAN[?] [hs numerical value]**

numerical value range: Dependent upon the signal source if the source is supported on the 8003's private bus. If not supported then the range is 1 MHZ to 99 GHZ.

Modifier Description: This modifier defines a POWER LEVEL for the start/stop swept frequency mode of signal source. The query flag ("?") affixed to the power level modifier queries the value of the power level. If set, the next time the 8003 is talk-addressed it will output the value of the power level in

8003 Precision Scalar Analyzer

	dBm. The resolution is 0.01 dBm. The format of the returned data is $\pm D.dd$, where D is zero to three digits and the assumed units are dBm.
Modifier name:	LEVEL, LEVEL?, PL, PL?
Modifier Syntax 1:	PL[?] [<i>hs</i> numerical value]
numerical value range:	Dependent upon the signal source if the source is supported on the 8003's private bus. If not supported then the range is -99 to +99 dBm.
Modifier Syntax 2:	PL <i>hs</i> on
State definition:	OFF, ON
Modifier Description:	<p>This modifier defines a SWEEP TIME for the start/stop swept frequency mode of signal source. The query flag ('?') affixed to the sweep time modifier queries the value of the sweep time. If set, the next time the 8003 is talk-addressed it will output the value of the sweep time in ms. The resolution is 1 ms. The resolution is 1 ms. The format of the returned data is:</p> <p>D where D is two to five digits</p>
Modifier name:	SWPT, SWPT?, ST, ST?
Modifier Syntax:	PL[?] [<i>hs</i> numerical value]
numerical value range:	Dependent upon the signal source if the source is supported on the 8003's private bus. If not supported then the range is 940 to 9000 ms.
Modifier Description:	<p>The update modifier decouples analyzer frequency updates from sweeper frequency updates. This is most commonly used when the analyzer and sweeper are set to different frequencies, as in mixer or frequency multiplier measurements. The analyzer normally uses frequency information to change the operating frequencies of the sweeper, annotate the x-axis of the swept display, apply correct Cal Factors to the reading, take the correct portions of trace memories and path cal memories, and fix cursors and markers. The update modifier allows independent control of the sweeper frequencies and all other frequency related analyzer functions. If the modifier UPD ON is included once with the SWPF, SWPS, or FIXED verbs, then all subsequent uses of those verbs will update the sweeper frequency along with the analyzer frequency. If the modifier UPD OFF is included once with the above verbs, then all subsequent uses of those verbs will change only analyzer frequency parameters.</p>
Modifier name:	UPD
Modifier syntax:	UPD <i>hs</i> state
State definition:	ON, OFF

Description: This verb places the signal source mode to center/span swept frequency. This is an instrument wide command and, as such, has no channel or sensor specifiers. However there are many parameters associated with the source mode. These are defined by the modifiers which follow the verb.

3.3.30 Sensor Path Calibration Command Structure

THRU, PATH

Syntax: **THRU** *hs* Sensor Specifier [*us* modifier] **EOL**

Example: **PATH A;srq EOL**

Specifiers: **A, B, or C**

Modifiers: This modifier is to request that a service request be sent upon completion of the Sensor Path Calibration.

Modifiers name: **Full Band, Narrow Band**

Modifier Syntax 1: **FB, NB**

Modifier name: **SRQ**

Modifier Syntax 2: **SRQ**

If the SRQ modifier is received, the 8003 will path calibrate the specified sensor. When the calibration is complete, the event complete bit will be set in the external status register and the service request and the external status bits will be set in the instrument status byte.

Description: This verb defines and initiates a Sensor Path Calibration.

3.3.31 Sensor Zeroing Command Structure

ZERO

Syntax: **CAL** *hs* Sensor Specifier [*us* modifier] **EOL**

Example: **ZERO B EOL**

Specifiers: **A, B, or C**

Modifiers: This modifier is to request that a service request be sent upon completion of the Sensor Zeroing.

Modifier name: **SRQ**

Modifier Syntax: **SRQ**

If the SRQ modifier is received the 8003 will zero the specified sensor. When the zeroing is complete, the event complete bit will be set in the external status register and the service request and the external status bits will be set in the instrument status byte.

Description: This verb defines and initiates Sensor Zeroing.

3.3.32 STATUS MESSAGES

3.3.32.1 488.2 Status Byte

The 8003 supports the IEEE 488.2 1988 definition of the STATUS BYTE. This status message is returned in response to a serial poll. The status message is coded as follows:

most significant bit(7):	not used
bit(6):	request service
bit(5):	External status register has message
bit(4):	not used
bit(3):	not used
bit(2):	not used
bit(1):	not used
bit(0):	not used

Whenever the value of bit 6 is true, the 8003 is requesting service. This will generate a service request message (SRQ TRUE) on the bus. The reason for the service request is always coded into the external status message. Therefore, the value of bit 5 will also be true. To discover the meaning of the service request the host computer must read the external status register. Reading the status byte via a serial poll will clear the status byte.

3.3.32.2 488.2 External Status

The 8003 supports the IEEE 488.2 1988 definition of the External Status Register. This status message is returned in response to an external status register query. The command for this is *ESR? and is defined as a command verb. Please see the Common Structure in Section 3.3.1 for a more detailed description of VERB. The status message is coded as follows:

most significant bit(15):	not used
bit(14):	not used
bit(13):	not used
bit(12):	not used
bit(11):	not used
bit(10):	not used
bit(9):	not used
bit(8):	not used
bit(7):	Power on flag
bit(6):	not used
bit(5):	Command error (Syntax error)
bit(4):	Execution error (operation error)
bit(3):	not used
bit(2):	Sampling Sensor Temperature Flag. This bit indicates that the Peak Power Sensor (when used with the instrument) has changed temperature by more than ± 5 °C since its last calibration, and should be recalibrated for maximum accuracy. The indication will be returned as 0 if the temperature is within range, or as 1 if out of range.
bit(1):	not used
bit(0):	Operation complete (Data ready flag/calibration complete)

To read the external status register, the host computer first sends the *ESR? VERB and then talk addresses the 8003. After the register has been read, it is cleared.

3.3.33 GPIB/PRIVATE Interface

Programming commands, controller command bytes, various data, and SRQs can be passed through the 8003 from the controller to instruments connected to the 8003's GPIB/PRIVATE interface port, located on the rear panel. This is accomplished by first sending the pass through command **PT d**, where **d** is the decimal address of the GPIB/SYSTEM interface. Subsequent addressing of the GPIB/SYSTEM interface will pass through commands to the selected device. The **PT d** command can be sent at any time. The default addresses for pass through commands are as follows:

8003 GPIB/SYSTEM Interface:	4 decimal
Source:	20 decimal
Plotter:	05 decimal
Printer:	01 decimal

The next section explains how to pass through commands to instruments connected to the 8003 GPIB/PRIVATE interface.

3.3.34 Pass Through Feature

The GPIB/PRIVATE rear panel connector is physically similar to the GPIB/SYSTEM interface port, but it is used specifically to control all compatible sources, plotters, and printers that are being used in the setup.

The transfer of commands and data is performed by first sending a Pass Through command **PT d** to the 8003, where **d** is the decimal address of the desired device. Subsequent addressing of the GPIB/PRIVATE interface will pass through commands to the selected instrument.

The address of the GPIB/PRIVATE interface is determined by complementing the least significant bit of the current 8003 address. For example, since the 8003 default address is 4 decimal = 0100 binary, the default GPIB/PRIVATE address is 5 decimal = 0101 binary. As another example, if the 8003 address were set to 7 decimal = 111 binary, the GPIB/PRIVATE address would become 6 decimal = 110 binary.

An example of how to pass through commands to the source with address 20 using the 8003 default address (4 decimal) is:

1. Address device 4 (the GPIB/SYSTEM interface on the 8003) and send the command **PT 20**.
2. Address device 5 (the GPIB/PRIVATE interface) and send commands to the source.
3. Address device 4. This returns the 8003 to its normal GPIB/SYSTEM operation.

An example of how to pass through commands to the plotter with address 05 decimal using the 8003 default address (4 decimal) is:

1. Address device 4 (the GPIB/SYSTEM interface) and send the command **PT 05**.
2. Address device 5 (the GPIB/PRIVATE interface) and send commands to the plotter.
3. Address device 4. This returns the 8003 to its normal GPIB/SYSTEM operation.

Performance Test & Calibration

4.1 General

Information in this section is useful for periodic evaluation of the 8003 Precision Scalar Analyzer and its power sensors. These tests can also be used for incoming inspection testing when the instrument is first received, if required.

If the 8003 has not previously been used, this manual should be reviewed to ensure that the instructions covering power requirements (Chapter 1) and GPIB address selection (Chapter 2), for example, have been complied with before the instrument is turned on. Prior to starting the following procedures, the instrument should be allowed to warm up for at least 30 minutes to assure maximum stability during testing.

The Specification Test for the Calibrator Output Power Reference Level given in this section is valid for an ambient temperature range between +15°C and +35°C (+59°F to +95°F).

The instrument plus power sensor linearity test is valid when the sensor has been calibrated using the front panel calibrator at a temperature between 0°C and +50°C (+32°F to +122°F), and if operating within $\pm 5^\circ\text{C}$ ($\pm 9^\circ\text{F}$) of that calibration temperature.

It is recommended that the verification be done in the order described since some of the steps use the configuration from a previous step.

As an aid to executing the steps presented, keystroke sequences used on the 8003 are shown in the outer column of the page. Also, as in the preceding chapters, a distinction is made between the front panel “hardkeys” and the CRT adjacent “softkeys”. The “hardkeys” are shown in **BOLD**, for example, **[CONFIG]**, and the softkeys are shown in *ITALICS*, for example, *[SENSORSAC/DC]*.

For information on how to calibrate the 8003 refer to Chapter M2, Maintenance, in the 8003 Maintenance Manual (P/N 20791-001).

8003 Precision Scalar Analyzer

Table 4-1: Test Equipment Required

Description	Representative Key	Key Characteristics
Microwave Sweeper	Giga-tronics 12720A	8003 Supported
Oscilloscope	Tektronix 2235	BW = > 100 kHz; Sens = > 2V/DIV
CW Thermistor Power Meter	HP 432A	V _{RF} and V _{COMP} available externally
Thermistor Mount	HP 478A-H75	≤1.07 VSWR @ 50 MHz (30 dB return loss) Accuracy ±0.5% @ 50 MHz
Digital Voltmeter (DVM)	Fluke 8842A	±0.05% accuracy & 1 mV resolution
Directional Coupler, 10 dB	Mini Circuits ZFDC-10-1 10 dB	≤1.15 SWR @ 50 MHz
Step Attenuator, 0 to 90 dB	Weinshel Model AC 118A-90-33	≤1.15 SWR @ 50 MHz±0.1 dB attenuation
RF Source (Signal Generator) (High Power)	Wavetek Model 2405 Option XP	+22 dBm @ 50 MHz
Low Pass Filter	Integrated Microwave Model 904 881	> 30 dB attenuation @ 100 MHz
GPIB Controller	IBM PC	National GPIB Card or equivalent
Printer	HP LaserJet Series II	RS-232 Interface & Command Set
High Resolution Color Display Monitor (Required 60 Hz Field Rate for 8003 Option 02 only)	NEC Multisync	31 kHz Line Rate 60 Hz Field Rate RGB Input



NOTE: Performance Verification Test Data Recording sheets are located starting on page 4-14. These sheets can be copied, and the copies used for recording test results each time that specification and performance verification testing is performed on this instrument.

4.2 Calibrator Verification Procedure

If any of the instrument performance characteristics are not within specifications, refer the problem to Giga-tronics Customer Service.

4.2.1 Calibrator Output Power Reference Level

This test determines if the Calibrator Output Power Reference Level given in this section is valid for an ambient temperature range between +5°C and +35°C (+41°F to +95°F).

The Calibrator Output power reference is factory adjusted to 1 mW $\pm 0.7\%$. To achieve this accuracy, Giga-tronics uses a precision measurement system with accuracy to $\pm 0.5\%$ (traceable to the NIST - formerly the NBS), and allows for a transfer error of $\pm 0.2\%$ for a total of $\pm 0.7\%$. If an equivalent measurement system is used for verification, the power reference oscillator output can be verified to 1 mW $\pm 1.9\%$ ($\pm 1.2\%$ accuracy, $\pm 0.5\%$ verification system error, $\pm 0.2\%$ transfer error, for a maximum error of $\pm 1.9\%$). To ensure maximum accuracy in verifying the Calibrator Output power reference, the following procedure provides step-by-step instructions for using specified test instruments of known capability. If equivalent test instruments are substituted, refer to the Key Characteristics section in Table 4-1.

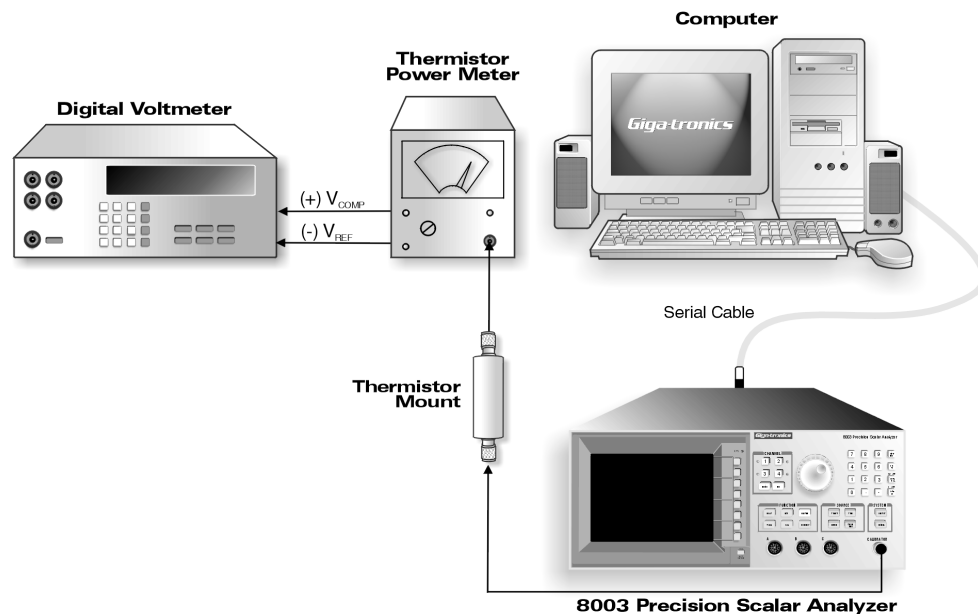

Figure 4-1: Calibrator Output Test Setup

4.2.1.1 Procedure

In the following steps, thermistor power measurements will be made using the 432A Power Meter. For detailed information on using the 432A, please refer to the operating section on the 432A manual.

1. Connect the 432A to the Calibrator Output on the 8003 as shown in Figure 4-1.
2. Turn on all equipment and then wait 30 minutes for the thermistor mount to stabilize before proceeding to the next step.

8003 Precision Scalar Analyzer

- Set the 432A RANGE switch to COARSE ZERO, and adjust the front panel COARSE ZERO control to obtain a zero ($\pm 2\%$ F.S.) meter indication.



NOTE: Ensure that the DVM input leads are isolated from chassis ground when performing the next step.

- Set the DVM to a range that results in a resolution of $1\ \mu\text{V}$ and connect the positive and negative input, respectively, to the V_{COMP} and V_{RF} connectors on the rear panel of the 432A.
- Fine zero the 432A on the most sensitive range, then set the 432A range switch to 1 mW.
- Record the DVM indication as V_0 .
- Turn ON the 8003 Calibrator RF power as follows:

Press **[CONFIG]** [*SERVICE*] [*SET CAL*]

In the "System" section of the front panel of the 8003 is a key [*SET CAL*] labeled **CONFIG**. Press this key and a menu will appear with a softkey labeled *SERVICE*. Press this key and another menu will appear with a softkey labeled *SET CAL*. Press [*SET CAL*]. Record the reading shown on the DVM as V_1 .



NOTE: The V_1 reading must be taken within 15 seconds after pressing [*SET CAL*]. Otherwise, press the *ABORT* softkey and repeat Steps 6 and 7.

- Disconnect the DVM negative lead from the V_{RF} connector on the 432A, and reconnect it to the 432A chassis ground. Record the new indication observed on the DVM as V_{COMP} .
- Press the *ABORT* softkey on the 8003.
- Calculate the Calibrator Output level (P_{CAL}) using the following formula:

$$P_{\text{CAL}}(\text{Watts}) = \frac{2V_{\text{COMP}}(V_1 - V_0) + V_0^2 - V_1^2}{4R(\text{Calibration Factor})}$$

where:

P_{CAL} = calibrator output power reference level
 V_{COMP} = previously recorded value in Step 8
 V_1 = previously recorded value in Step 7
 V_0 = previously recorded value in Step 6
 $R = 200\ \Omega$ (assuming HP478A-H75 mount)

Calibration factor = value for the thermistor mount at 50 MHz (traceable to the NIST)

- Verify that the P_{CAL} is within the following limits:

$$1\ \text{mW} \pm 0.019\ \text{mW} \text{ (0.981 to 1.019 mW)}$$

For record purposes, the measured value of P_{CAL} can be entered on the Performance Verification Test Data Recording Sheet starting on page 4-14.

4.2.2 Calibrator Frequency Check

To measure the frequency of the calibrator:

1. Connect the frequency counter to the calibrator output connector.
2. Turn ON the calibrator according to the procedure given in Procedure Step 8 on the previous page.
3. Measure 49 to 51 MHz.
4. Set the calibrator frequency to 1.000 GHz (with Option 12 only).
5. Measure 999.5 MHz to 1.0005 GHz (with Option 12 only).
6. Turn the calibrator OFF.

4.3 Performance Verification Tests

Information in this section is useful for periodic evaluation of the 8003 and its power sensors. These tests can also be used for incoming inspection testing when the instrument is first received, if required.

If the 8003 has not previously been used, review the precautions in Section 1.2.1 of the manual before the instrument is turned on. Prior to starting the following procedures, the instrument should be allowed to warm up for at least 24 hours to assure maximum stability during testing.

The instrument plus power sensor linearity test is valid when the sensor has been calibrated using the front panel calibrator at a temperature between 0°C and +50°C (+32°F to +122°F), and if operating within $\pm 5^\circ\text{C}$ ($\pm 9^\circ\text{F}$) of that calibration temperature.

It is recommended that the verification be done in the order described since some of the steps use the configuration from a previous step.

4.3.1 Equipment Required

See Table 4-1 for a list of the equipment required for performance testing of the 8003 Precision Scalar Analyzer.

Performance Verification Test Data Recording sheets are located on pages 4-14 thru 4-17. These sheets can be copied used for recording test results each time specifications and performance verification testing is performed on the specific instrument described by this manual.

4.3.2 Instrument Plus Power Sensor Linearity

4.3.2.1 Test Description

Connect the test setup as shown in Figure 4-2. The linearity will be tested over the range +20 dBm to -60 dBm (CW Mode) and +20 dBm to -50 dBm (Swept Mode). At low power levels, the linearity measurement will include the uncertainty due to the zero set specification. The procedure should be repeated for each sensor used with the 8003.

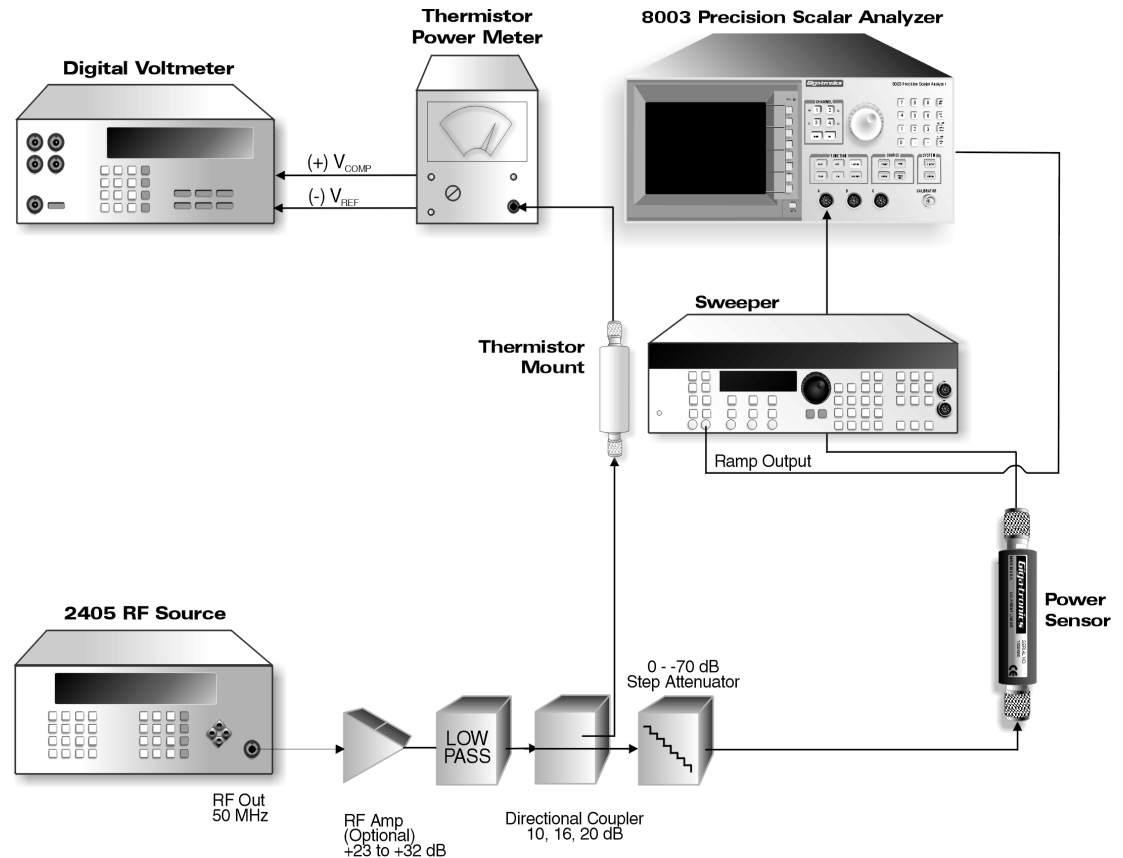

Figure 4-2: Power Linearity Test Setup

When measuring the linearity of a low VSWR (8031XA Series) or a high power sensor (8032XA Series) sensor, the power output of the source as well as the directional coupler coupling factor, must be increased from 10 dB to either 16 or 20 dB respectively (see Figure 4-2). The power coefficient of the step attenuator will also have to be considered. The specification of power coefficient for the Weinschel attenuator cited in the Equipment List is: <0.005 dB/(dB/W). The latter will affect the linearity of each 10 dB segment, and make it necessary to expand the overall linearity specification by this quantity.

In assembling the test setup shown in Figure 4-2, keep in mind that if testing is to be conducted with Low VSWR or High Power sensors, the optional RF Amplifier must have frequency and bandwidth parameters to match the sensor's characteristics (see the Sensor Selection Guide in Appendix A, if unsure of characteristics), and the Directional Coupler must be increased as stated above for the particular series of sensors. All Standard (8030XA Series) and True RMS (8033XA Series) sensors are tested with a 10 dB Directional Coupler and without the optional RF amplifier, and with a 10 dB Directional Coupler.

8003 Precision Scalar Analyzer

Refer to the CW Linearity Data and the Swept Linearity Data sections of the 8003 Performance Verification Test Data Sheets located on pages 4-14 through 4-17. These sections facilitate the collection of data for the CW and Swept power linearity tests. The tolerance is already entered for the various steps, and includes an allowance for specified zero set errors at low power levels.



NOTE: To ensure accurate and repeatable measurements, the 432A power meter should be zeroed just before taking each reading that will be used to calculate P1 in the Power Meter column of the Performance Verification Test Data Sheets on pages 4-14 through 4-17.

4.3.2.2 Setup Parameters

The following setup parameters should be accomplished prior to performing the Power Linearity test:

1. The 8003 and sensor should be calibrated.
2. The 8003 is placed in the CW mode by pressing the **DEFINE** key and toggling the CW/SWEPT softkey if necessary.

[DEFINE] [CW]

3. A “Readout” display is obtained by pressing the **DISPLAY** key and toggling the GRAPH/READOUT softkey as required.

[DISPLAY] [READOUT1]

4. Set the 8003 to display linear units of power (mW) by pressing the **DISPLAY** key and selecting the appropriate UNITS soft-key labels.

[DISPLAY] [UNITS]
[LINEAR]

5. The CW Averaging is set to 4 by entering the key sequence shown to the left.

[DISPLAY] [AVG][4]
[ENTER][AVG ON]

4.3.2.3 Test Procedure

[CAL] [ZERO SENSOR]
[SENSOR A/B/C ZERO]

Extreme care is required in the following procedure since the accuracy requirements are critical to ensure the most accurate test results.

Power readings are determined using the thermistor power meter in the same general way as given in the Power Reference Level test. That is, P1 and P2 north Power Meter reading column of the Performance verification Test Data Sheet tables are calculated each time for the respective values of V_{COMP} , V_0 , and V_1 read on the DVM.

1. Set the step attenuator to 70 dB. Turn the source power output off, and then zero the 8003.
(The 8003 is zeroed by pressing **CAL** key located in the “Function” section on the front panel, and then following the softkey label instructions).

2. Set the step attenuator to 0 dB after the 8003 chimes to signal the completion of the zeroing process.
3. Set the power output of the RF source so that the thermistor power meter indicates 1.00 mW ± 0.025 mW.
4. Record the calculated power meter reading and the displayed 8003 reading in the correct columns of the Linearity Data Recording sheet on page 4-14.
5. Set the power output of the RF source so that the thermistor power meter indicates 3.98 mW ± 0.10 mW.
6. Record the new calculated power meter reading and the new displayed 8003 reading as in Step 4, above.
7. Set the power output of the RF Source so that the thermistor power meter indicates 5.01 mW ± 0.10 mW.
8. Record the new calculated power meter reading and the new displayed 8003 reading as in Step 4, above.
9. Repeat using the power meter indications in the data sheet on page 4-15. Note that the Step Attenuator is used to generate the remaining 70 dB range of 10 dB steps for a total range of 80 dB. Repeat Step 1, above, between each 10 dB step shown on the Linearity Data Recording sheet.
10. Make the calculations indicated on the Linearity Data sheet, and enter the values in the appropriate blank spaces.
11. Repeat Steps 1 through 10 using the Swept Mode (1 second sweep), and record the results on the Swept Linearity Data sheet (page 4-16).

[DEFINE] [SWEPT]



NOTE: In the Swept mode it is necessary to calculate the linear power from the dBm reading on the 8003. Also, be sure that the Start and End frequencies are set to 50 MHz.

8003 Precision Scalar Analyzer

4.3.3 Serial Port Check

The following steps are used to confirm that the RS-232 port on the 8003 is functional. The following are the factory default settings for the communications parameters on the serial port of the 8003:

Baud Rate: **9600**
Parity: **N**
Data Bits: **8**
Stop Bits: **1**

If required, the 8003 can support baud rates of 1200, 2400 and 4800 by moving W8 on the Processor PC Board (A12).

1. Configure the 8003 to be in Graph Mode.
[DISPLAY] [GRAPH]
2. Connect the RS-232 cable between the Serial Port on the rear of the 8003 and the Serial Port on the LaserJet printer.
[DISPLAY] [PLOT & PRINT]
3. Print a graph.
[PRINT] [LASER PRINT]



NOTE: Paint Print and Ink Print can only be executed over the GPIB.

4.3.4 GPIB/System Port Check

The following steps confirm that the GPIB port is functional:

1. Set the 8003 to the desired address (the default is 4).
[CONFIG] [GPIB DEVICES]
[nn] [ENTER]
2. Connect the GPIB controller to the GPIB Port on the rear of the 8003.
3. Send the command (if emulating an HP 438):
***IDN? or ?ID**

The verb is the standardized COMMON identify query command as defined by IEEE 488.2 1988. When talk addressed after receiving the command, the 8003 will output a string that identifies itself as the 8003 Scalar Network Analyzer.

(*IDN? is the IEEE 488.2 Common ID query. When addressed to talk after receiving the command, the 8003 will output a string that identifies itself as 8003 Scalar Network Analyzer).

4. Display the response on the controller. For further information on using the 8003 through the GPIB, refer to Chapter 3.

4.3.5 GPIB/Private Port Check

1. Connect the 12720A GPIB port to the GPIB/Private Port on the rear of the 8003 (or one of the other supported sweepers listed in section B.3.3).
2. Determine the GPIB address of the 12720A. Press the CONFIG button located on the front panel. Press the GPIB softkey next to the GPIB display. Read the GPIB address on the GPIB Parameters Menu.
3. Enter the address obtained in Step 2 as the Source Address on the 8003.
[CONFIG] *[GPIB DEVICES]*
[SOURCE ADDRESS] **[nn]**
[ENTER]
4. Check that the 8003 recognizes the sweeper by verifying that sweeper dependent softkey selections on the 8003 (such as “Power”) are NOT dark blue.
[POWER] *[Softkey labels are green or blue]*

4.3.6 Sweep in Connector Check

1. Connect the Sweep Out connection from the sweeper to the Sweep In on the 8003.
2. Configure the 8003 to be in the Graph/Swept Mode.
[DISPLAY] *[GRAPH]*
[DEFINE] *[SWEPT]*
3. Select a swept time of 1 second.
[SWEEP TIME] **[1]** **[S]**
4. Calibrate the Sweep Ramp.
[CONFIG] *[CAL SWP RAMP]*
5. Display Channel and Autoscale.
[CH 1] **[SCALE]** *[Autoscale]*
6. Disconnect, and then connect the BNC cable to the Sweep In connector on the 8003.
7. Observe that the trace is being swept only when the BNC cable is connected.

4.3.7 AC Mode Output Connector Check

The 8003 AC Modulation Output voltage default values are +5V (AC Modulation off), and a square wave switching between +5V and 0V (AC Modulation on), at a nominal 1kHz frequency. The 8003 can generate different voltages using values stored in an internal lookup table depending on the sweeper to which it is connected via the GPIB/Private port.

1. Connect the AC Mod Output to the Vertical input on the oscilloscope. Set the oscilloscope as follows:

Coupling: **DC**
Volts/Div: **2V /Div**
Time/Div: **200 μ s/Div**
Triggering: **AC/Auto/Int**

2. Ground the oscilloscope input and center the trace.
3. Set the 8003 to the DC Mode of operation.

[CONFIG] [SENSORS AC/DC]
[ALL DC]

4. Select DC coupling on the oscilloscope, and check that it indicates a positive voltage of 5V.
5. Set the 8003 to the AC Mode of operation.

[CONFIG] [SENSORS AC/DC]
[ALL DC]

6. Check that the oscilloscope displays a square wave, repetition frequency between 500 Hz and 1.5 kHz, voltage between 0V and +5V.

4.3.8 Bias Output Connector Check

The following steps are used to confirm that the Bias Output Voltage connector is functional. These steps can be bypassed if it not intended to use this capability for applications such as supplying power to PIN diode attenuators.



NOTE: *The Bias Voltage Output is channel dependent, and only on during the sweep time for each channel which has been configured by the user to output a bias voltage.*

In the following procedure it is recommended that the 8003 be set to display channel only, and that a sweep time of 1 second be set on the sweeper.

[CH 1] [CH 2] [OFF] [CH 3]

[OFF] [CH 4] [OFF] [SWEEP TIME] [1] [S]

1. Set the 8003 to be in the Graph/Swept Mode.

[DISPLAY] [GRAPH] [DEFINE] [SWEPT]

2. Connect the Bias Output Voltage connector on the rear of the 8003 to the vertical input of the oscilloscope. Set the oscilloscope as follows:

Volts/Div: **5V /Div**
Time/Div: **200 μ s/Div**
Triggering: **AC/Auto/Int**

3. Ground the oscilloscope input and center the trace.
4. Select DC coupling on the oscilloscope.
5. Set the Bias Output Voltage on the 8003 to + 10V.
[DEFINE] [BIAS VOLTAGE] [1] [0] [S]
6. Check that the trace on the oscilloscope moves up 2 divisions (+10V) from center screen during the sweep, and back to center (0V) on retrace.
7. Set the Bias Voltage Output on the 8003 to -10V.
[DEFINE] [BIAS VOLTAGE] [-] [1] [0] [S]
8. Check that the trace on the oscilloscope moves down 2 divisions (-10V) from center screen during the sweep, and back to center (0V) on retrace.

4.3.9 DAC Output Connector Check

Not Presently Used.

4.3.10 RGB Video Output Connector Check

Connect the 8003 Op 02 RGB Video Output to the High Resolution Color Display Monitor and display a stable color picture that duplicates the display on the 8003.

4.3.11 SUMMARY

This completes the performance test and calibration tests for the 8003 Precision Scalar Analyzer and its sensors. If the instrument has performed as described in this chapter, it is correctly calibrated and within specifications.

If the instrument fails to meet any of the criteria defined in the tests, refer to the calibration and/or maintenance sections of the 8003 Maintenance Manual (P/N 20791-001).

8003 Precision Scalar Analyzer

GIGA-TRONICS 8003 Performance Verification Test Data Recording Sheet

Date:	
Operator:	
Test Number:	(If required)
8003 S/N:	
Power Sensor S/N:	

Calibrator Output Power Reference

Minimum	Actual Reading	Maximum
0.981 mW		1.019 mW

Linearity Data (+16 dBm to +20 dBm)

Step Attenuator Value	Power Set Point	Power Meter Reading (P)	8540 (DUT) Reading (R)	Reference Power Ratio	8540 (DUT) Reading Ratio	Linearity Error (%) ¹	
						Linearity Specification	Accumulated Linearity Error ²
0 dB	1.00 mW ±0.025 mW	P1 =	R1 =	P1/P2 =	R1/R2 =	±1%	Same as Lin. error above
	3.98 mW ±0.10 mW	P2 =	R2 =				
0 dB	3.98 mW ±0.10 mW	P1 =	R1 =	P1/P2 =	R1/R2 =	+1% -1.6%	
	5.01 mW ±0.13 mW	P2 =	R2 =				
0 dB	5.01 mW ±0.13 mW	P1 =	R1 =	P1/P2 =	R1/R2 =	+1% -2.7%	
	6.31 mW ±0.16 mW	P2 =	R2 =				
0 dB	6.31 mW ±0.16 mW	P1 =	R1 =	P1/P2 =	R1/R2 =	+1% -3.8%	
	7.94 mW ±0.2 mW	P2 =	R2 =				
0 dB	7.94 mW ±0.2 mW	P1 =	R1 =	P1/P2 =	R1/R2 =	+1% -4.9%	
	10 mW ±0.25 mW	P2 =	R2 =				
(continued)							

+16 dBm to -60 dBm Linearity Data is on the next page.

NOTES:

- Linearity Error (%) = $[(R1/R2) / (P1/P2) - 1] \times 100$
- Accumulated error is the sum of the current dB segment linearity error plus the previous accumulated error.

CW Linearity Data - (+16 dBm to -60 dBm)							
Step Attenuator Value	Power Set Point	Power Meter Reading (P)	8540 (DUT) Reading (R)	Reference Power Ratio	8540 (DUT) Reading Ratio	Linearity Error (%) ¹	
						Linearity Specification	Accumulated Linearity Error ²
0 dB						See Note 3	
						±1%	Same as Lin. error above
10 dB	1.00 mW ±0.025 mW	P1 =	R1 =	P1/P2 =	R1/R2 =		
	10.00 mW ±0.25 mW	P2 =	R2 =			±1%	
20 dB	1.00 mW ±0.025 mW	P1 =	R1 =	P1/P2 =	R1/R2 =		
	10.00 mW ±0.25 mW	P2 =	R2 =			±1%	
30 dB	1.00 mW ±0.025 mW	P1 =	R1 =	P1/P2 =	R1/R2 =		
	10.00 mW ±0.25 mW	P2 =	R2 =			±1%	
40 dB	1.00 mW ±0.025 mW	P1 =	R1 =	P1/P2 =	R1/R2 =		
	10.00 mW ±0.25 mW	P2 =	R2 =			±1%	
50 dB	1.00 mW ±0.025 mW	P1 =	R1 =	P1/P2 =	R1/R2 =		
	10.00 mW ±0.25 mW	P2 =	R2 =			±1%	
60 dB (Increase avg. to 8)	1.00 mW ±0.025 mW	P1 =	R1 =	P1/P2 =	R1/R2 =		
	10.00 mW ±0.25 mW	P2 =	R2 =			±1.5%	
70 dB (Increase avg. to 16)	1.00 mW ±0.025 mW	P1 =	R1 =	P1/P2 =	R1/R2 =		
	10.00 mW ±0.25 mW	P2 =	R2 =			±6%	

NOTES:

1. Linearity Error (%) = $[(R1/R2) / (P1/P2) - 1] \times 100$
2. Accumulated error is the sum of the current dB segment linearity error plus the previous accumulated error.
3. Use the first CW Linearity error value entered in the +16 dBm to +20 dBm Linearity Data on page 4-14.

8003 Precision Scalar Analyzer

Swept Linearity Data (+16 dBm to +20 dBm)							
Step Attenuator Value	Power Set Point	Power Meter Reading (P)	8003 (DUT) Reading (R)	Reference Power Ratio	8003 (DUT) Reading Ratio	Linearity Error (%) ¹	
						Linearity Specification	Accumulated Linearity Error ²
0 dB	1.00 mW ±0.025 mW	P1 =	R1 =	P1/P2 =	R1/R2 =	±1%	Same as Lin. error above
	3.98 mW ±0.10 mW	P2 =	R2 =				
0 dB	3.98 mW ±0.10 mW	P1 =	R1 =	P1/P2 =	R1/R2 =	+1% -1.6%	
	5.01 mW ±0.13 mW	P2 =	R2 =				
0 dB	5.01 mW ±0.13 mW	P1 =	R1 =	P1/P2 =	R1/R2 =	+1% -2.7%	
	6.31 mW ±0.16 mW	P2 =	R2 =				
0 dB	6.31 mW ±0.16 mW	P1 =	R1 =	P1/P2 =	R1/R2 =	+1% -3.8%	
	7.94 mW ±0.2 mW	P2 =	R2 =				
0 dB	7.94 mW ±0.2 mW	P1 =	R1 =	P1/P2 =	R1/R2 =	+1% -4.9%	
	10 mW ±0.25 mW	P2 =	R2 =				
(continued)							

+16 dBm to -50 dBm Swept Linearity Data is on the next page.

NOTES:

1. Linearity Error (%) = $[(R1/R2) / (P1/P2) - 1] \times 100$
2. Accumulated error is the sum of the current dB segment linearity error plus the previous accumulated error.

Swept Linearity Data - (+16 dBm to -50 dBm)							
Step Attenuator Value	Power Set Point	Power Meter Reading (P)	8540 (DUT) Reading (R)	Reference Power Ratio	8540 (DUT) Reading Ratio	Linearity Error (%) ¹	
						Linearity Specification	Accumulated Linearity Error ²
0 dB						See Note 3	
						±1.4%	Same as Lin. error above
10 dB	1.00 mW ±0.025 mW	P1 =	R1 =	P1/P2 =	R1/R2 =		
	10.00 mW ±0.25 mW	P2 =	R2 =			±1.4%	
20 dB	1.00 mW ±0.025 mW	P1 =	R1 =	P1/P2 =	R1/R2 =		
	10.00 mW ±0.25 mW	P2 =	R2 =			±1.4%	
30 dB	1.00 mW ±0.025 mW	P1 =	R1 =	P1/P2 =	R1/R2 =		
	10.00 mW ±0.25 mW	P2 =	R2 =			±1.4%	
40 dB	1.00 mW ±0.025 mW	P1 =	R1 =	P1/P2 =	R1/R2 =		
	10.00 mW ±0.25 mW	P2 =	R2 =			±1.5%	
50 dB	1.00 mW ±0.025 mW	P1 =	R1 =	P1/P2 =	R1/R2 =		
	10.00 mW ±0.25 mW	P2 =	R2 =			±2.4%	
60 dB (Increase avg. to 8)	1.00 mW ±0.025 mW	P1 =	R1 =	P1/P2 =	R1/R2 =		
	10.00 mW ±0.25 mW	P2 =	R2 =			±11.4%	

NOTES:

1. Linearity Error (%) = $[(R1/R2) / (P1/P2) - 1] \times 100$
2. Accumulated error is the sum of the current dB segment linearity error plus the previous accumulated error.
3. Use the first CW Linearity error value entered in the +16 dBm to +20 dBm Linearity Data on page 4-16.

Power Sensors

A.1 Introduction

This appendix contains the selection and specifications data for the Giga-tronics power sensors used with the 8003 Precision Scalar Analyzer.

Giga-tronics power sensors contain balanced zero-biased Schottky diodes for power sensing.

CAUTION

Input power in excess of +23 dBm (200 mW, which is the 100% average for standard and pulse sensors) can degrade or destroy these diodes. Diodes degraded or destroyed in this manner will not be replaced under warranty. Destructive signal levels are higher for high power, true rms, and low VSWR sensors. When connecting power sensors to other devices, do not turn the body of the sensor in order to tighten the RF connection. This can damage the connector mating surfaces.

A.2 Power Sensor Selection

Standard sensors include the 803XXA Series for CW signals, the 80500 Series CW Return Loss Bridges, and the 8033XA Series True RMS sensors.

Giga-tronics True RMS sensors are recommended for applications such as measuring quadrature modulated signals, multi-tone receiver intermodulation distortion power, noise power, or the compression power of an amplifier. These sensors include a pad to attenuate the signal to the RMS region of the diode's response. This corresponds to the -70 dBm to -20 dBm linear operating region of Standard CW Sensors. The pad improves the input VSWR to ≤ 1.15 at 18 GHz.

High Power (1, 5, 25 & 50 Watt) and Low VSWR sensors are also available for use with the 8003. Table A-1 lists the Giga-tronics power sensors used with the 8003. Refer to applicable notes on page A-3.

8003 Precision Scalar Analyzer

A.2.1 Power Sensor Selection Charts

Table A-1: Power Sensor Selection Guide

Model	Freq. Range/ Power Range	Max. Power	Power Linearity ⁴ (Freq > 8 GHz)	RF Conn	Lgth.	Dia.	Wgt	VSWR
CW Power Sensors								
200 mW Peak Power								
80301A	10 MHz to 18 GHz -70 to +20 dBm	+23 dBm (200 mW)	-70 to -20 dBm ±0.00 dB -20 to +20 dBm ±0.05 dB/10 dB	Type N(m) 50Ω	114.5 mm (4.5 in)	32 mm (1.25 in)	0.18 kg (0.4 lb)	1.12:0.01 - 2 GHz 1.22:2 - 12.4 GHz 1.29:12.4 - 18 GHz
80302A	10 MHz to 18 GHz -70 to +20 dBm			APC-7 50Ω				
80303A	10 MHz to 26.5 GHz -70 to +20 dBm		-70 to +20 dBm ±0.00 dB -20 to +20 dBm ±0.1 dB/10dB	Type K(m) ¹ 50Ω				
80304A	10 MHz to 40 GHz -70 to 0 dBm		-70 to -20 dBm ±0.00 dB -20 to 0 dBm ±0.2 dB/10 dB					
Low VSWR CW								
80310A	10 MHz to 18 GHz -64 to +26 dBm	+29 dBm (800 mW)	-64 to -14 dBm ±0.00 dB -14 to +26 dBm ±0.05 dB/10 dB	Type K(m) ¹ 50Ω	127mm (5.0 in)	32 mm (1.25 in)	0.23 kg (0.5lb)	1.13:0.01 - 2 GHz 1.15:2 - 12 GHz 1.23:12 - 18 GHz 1.29:18 - 26.5 GHz 1.50:26.5 - 40 GHz
80313A	10 MHz to 26.5 GHz -64 to +26 dBm		-64 to -14 dBm ±0.00 dB -14 to +26 dBm ±0.1 dB/10 dB					
80314A	10 MHz to 40 GHz -64 to +6 dBm		-64 to -14 dBm ±0.00 dB -14 to +6 dBm ±0.2 dB/10 dB					
1W CW								
80320A	10 MHz to 18 GHz -60 to +30 dBm	+30 dBm (1 W)	-60 to -10 dBm ±0.00 dB -10 to +30 dBm ±0.05 dB/10 dB	Type K(m) ¹ 50Ω	127 mm (5.0 in)	32 mm (1.25 in)	0.23 kg (0.5 lb)	1.11:0.01 - 2 GHz 1.12:2 - 12 GHz 1.18:12 - 18 GHz 1.22:18 - 26.5 GHz 1.36:26.5 - 40 GHz
80323A	10 MHz to 26.5 GHz -60 to +30 dBm		-60 to -10 dBm ±0.00 dB -10 to +30 dBm ±0.1 dB/10 dB					
80324A	10 MHz to 40 GHz -60 to +10 dBm		-60 to -10 dBm ±0.00 dB -10 to +10 dBm ±0.2 dB/10 dB					
True RMS Sensors (f_m > 1.5 MHz) (-30 to +20 dBm)								
80330A 80333A 80334A	10 MHz to 18 GHz 10 MHz to 26.5 GHz 10 MHz to 40 GHz	+33 dBm (2 W)	-30 to +20 dBm ±0.00 dB	Type K(m) ¹ 50Ω	152.5 mm (6.0 in)	32 mm 1.25 in)	0.27 kg (0.6 lb)	1.12:0.01 - 12 GHz 1.15:12 - 18 GHz 1.18:18 - 26.5 GHz 1.29:26.5 - 40 GHz
Triggerable Pulse Peak Power Sensors (f_m > 1.5 MHz) (-30 to +20 dBm)								
80340A 80343A	50 MHz to 18 GHz -20 to +20 dBm (Trig.) -30 to +20 dBm (Free Run) 50MHz to 26.5 GHz	+23 dBm (200 mW)	±0.13 dB, 0 dBm to -30dBm ±0.13 dBm, ±0.01 dB/dB from 0 dBm to +20 dBm	Type N(m) ¹ 50Ω	146 mm (5.75 in)	37 mm (1.44 in)	0.3 kg (0.6lb)	1.12:0.01 - 2 GHz 1.22:2 - 12.4 GHz 1.37:12.4 - 18 GHz
80344A	50 MHz to 40 GHz -20 to 0 dBm (Trig.) -30 to 0 dBm (Free Run)		±0.13 dB, 0 dBm to -30 dBm	Type K(m) ¹ 50Ω				

See NOTES next page

Table A-2: Power Sensor Cal Uncertainties

Freq. (GHz)		Root Sum of Squares (RSS) Uncertainties (%) ³					
Lower	Upper	80301A 80302A	80303A 80304A	80310A 80313A 80314A	80320A 80323A 80324A	80321A ⁴	80330A 80333A 80334A
Min	1	1.04	1.64	1.58	1.58	4.54	1.58
1	2	1.20	1.73	1.73	1.73	4.67	1.73
2	4	1.33	1.93	1.91	1.91	4.89	1.90
3	6	1.41	2.03	2.02	2.01	5.01	2.01
6	8	1.52	2.08	2.07	2.06	5.12	2.06
8	12.4	1.92	2.55	2.54	2.53	5.56	2.53
12.4	18	2.11	2.83	2.80	2.79	5.89	2.78
18	26.5	—	3.63	3.68	3.62	—	3.59
26.5	40	—	6.05	5.54	5.39	—	5.30

See NOTES below

NOTES:

1. The K connector is electrically and mechanically compatible with the APC-3.5 and SMA connectors. Use a Type N(m) to SMA(f) adapter (P/N 29835) for calibration of power sensors with Type K(m) connectors.
2. For frequencies above 8 GHz, add power linearity to system linearity.
3. Square root of sum of the individual uncertainties squared (RSS).
4. Cal Factor numbers allow for 3% repeatability when connecting attenuator to sensor, and 3% for attenuator measurement uncertainty and mismatch of sensor/pad combination.

8003 Precision Scalar Analyzer

A.2.2 Directional Bridges

The 80500 CW Directional Bridges are designed specifically for use with Giga-tronics power meters to measure the Return Loss/SWR of a test device. Each bridge includes an EEPROM which has been programmed with Identification Data for that bridge.

Table A-3: Directional Bridge Selection Guide

Bridge Selection Guide								
Model	Freq. Range/ Power Range	Max. Power	Power Linearity ⁴ (Frequency >8 GHz)	Input	Test Port	Directivity	Wgt	VSWR
Precision CW Return Loss Bridges								
80501	10 MHz to 18 GHz -35 to +20 dBm	+27 dBm (0.5W)	-35 to +10 dBm ±0.1 dB +10 to +20 dBm ±0.1 dB ±0.005 dB/dB	Type N(f) 50 Ω	Type N(f) 50 Ω	38 dB	0.340 kg	<1.17:0.01 - 8 GHz <1.27:8 - 18 GHz
80502					APC-7(f) 50 Ω	40 dB		<1.13:0.01 - 8 GHz <1.22:8 - 18 GHz
80503	10 MHz to 26.5 GHz -35 to +20 dBm			SMA(f) 50 Ω	SMA(f) 50 Ω	35 dB	<1.22:0.01 - 18 GHz <1.27:8 - 26.5 GHz	
80504	10 MHz to 40 GHz -35 to +20 dBm			Type K(f) 50 Ω	Type K(f) 50 Ω	30 dB	0.198 kg	<1.35:0.01 - 26.5 GHz <1.44:26.5 - 40 GHz

The Selection Guide in Table A-3 shows primary specifications. Additional specifications are:

Bridge Frequency Response:

Return loss measurements using the 8003 can be frequency compensated using the standard *Open/Short* supplied with the bridge.

Insertion Loss:

6.5 dB, nominal, from input port to test port

Directional Bridge Linearity Plus
Zero Set & Noise vs. Input Power:
(50 MHz, 25°C ±5°C, 0 dBm Ref.)

+27 dBm (0.5 W)

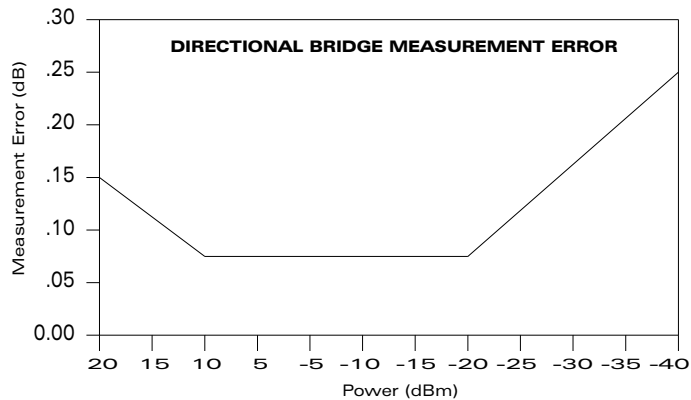

Weight:

80501: 340 g (12 oz)
80502: 340 g (12 oz)
80503: 198 g (7 oz)
80504: 198 g (7 oz)

Directional Bridge Accessories:

An Open/Short is included for establishing the 0 dB return loss reference during path calibration.

Dimensions:

80501: 76 x 50 x 28 mm (3 x 2 x 1 1/8 in)
80502: 76 x 50 x 28 mm (3 x 2 x 1 1/8 in)
80503: 19 x 38 x 29 mm (3/4 x 1 1/2 x 2 1/8 in)
80504: 19 x 38 x 29 mm (3/4 x 1 1/2 x 2 1/8 in)

System Configuration

B.1 Introduction

This appendix contains the default function settings for the 8003, it also contains instructions for the proper connection of the most common test equipment and the initial printer installation directions for the 8003's ability to generate hardcopies of displayed data and/or plots. It is assumed that the user has read all manuals for other test equipment in the system, and has set up the test equipment properly.

B.2 8003 Default Parameters

Factory programmed settings of various user definable functions have the following defaults whenever there have been no changes made to the settings by the operator during any test routines. The default settings are given for the CURSOR, SENSOR, DISPLAY, CHANNEL and SOURCE component parameters.

Table B-1: 8003 Default Settings

	Function	Default Setting
CURSOR	Cross Cursor	OFF, frequency at 10000 MHz
	Delta Cursor	OFF
	Markers	OFF
	Active Channel	1
SENSOR	Sensor Mode	DC
	Sensor Specific for Source of Frequency	Back Panel SWP Input
	Sensor Frequency	0.05 GHz
	Sensor Cal Factor	0
	Sensor Offset	0
	Sensor Full Band	
	Path Cal Option	NO
DISPLAY	Setup	Swept Mode
	Color Intensity	RED, GREEN, BLUE are bright
	Graticule Color	GREEN
	Frequency Label	ON
	Title	OFF

8003 Precision Scalar Analyzer

Table B-1: 8003 Default Settings (Continued)

	Function	Default Setting
CHANNEL	Mode	Swept Frequency
	Parameter	A, B, C A/B for Channels 1 through 4
	Color	CYAN, RED, YELLOW, MAGENTA for channels 1 through 4 respectively dB Mode.
	Format	dB mode.
	Memorized Trace	0
	Measurement	Absolute Measurement
	Average	OFF, average factor = 8
	Smoothing	OFF, smooth apert = 5%
	Continue Auto Scale	OFF
	Scale per Division	20 dB
	Reference Position	Center
	Reference Level	0 dB
	Bandwidth Search Value	-3.00 dB
	Channel Search Level	-3.00 dB
	CW Mode Setup	REL OFF
	Max Hold	OFF
	Min Hold	OFF
	Channel Title	OFF
Limit Line	OFF	
Modulate Bias Voltage	0 Volt	
SOURCE	Signal Source Mode	Start/Stop Swept Freq
	Start Frequency	Sweeper Start Frequency or 1 MHz if not controlled by the 8003
	Stop Frequency	Sweeper Stop Frequency
	Sweep Time	200 ms
	RF Power Level	OFF, minimum RF level of the signal source or 0 dBm if not controlled by the 8003.
	Source Modulation	OFF

B.3 8003 System

The 8003 Precision Scalar Analyzer is always used with other test equipment and accessories to make a complete component measurement system. See Section B.3.3.1 which outlines the proper connection of the most common test equipment.

B.3.1 Sensor Installation

The 8003 Precision Scalar Analyzer should be connected only to the Giga-tronics Series 803XXA Power Sensors. A special sensor cable is shipped with the 8003 to connect the power sensor to any of the three analyzer sensor inputs marked A, B, and C. The sensor cable is made specifically for the 8003 Analyzer and should not be used with other products. See Section A.2.1 for the technical specifications and data for the Series 803XXA Power Sensors used with the 8003 Scalar Analyzer.

To make swept component measurements, a scalar analyzer is always used with a swept microwave source (sweeper), one or more power sensors, and a microwave signal splitting device (usually a return loss bridge, directional coupler, or power splitter).

B.3.2 Bridge Installation

Only Giga-tronics Series 80500 Return Loss Bridges can be used with the 8003 Analyzer. If you are using a bridge, it should be connected to any of the three analyzer sensor inputs marked A, B, or C via the sensor cable shipped with the analyzer.



NOTE: *The bridge uses the same sensor cable as the power sensors.*

B.3.3 Sweeper Installation

The 8003 supports the following sweepers:

- Giga-tronics 12720A
- Giga-tronics 7200 Series or 910 Series Synthesized Sweep Generators
- Giga-tronics 610 Series Sweep Oscillator
- HP8350A/B with an RF plug-in (HP86200 series with the HP11869A adapter)
- HP8340A/B, HP8341A/B or HP8360 Synthesized Sweepers
- Marconi 6300 Series Sweepers
- Wiltron 6600B Sweep Generators
- Wiltron 6700B Synthesized Sweep Generators

The 8003 supports a variety of sweepers. Because the analyzer requires several connections to the microwave sweepers, please refer to the installation interconnection instructions on this page and the next.

B.3.3.1 8003 to Sweeper BNC Connections

Connections shown in capital letters are the actual function names printed on the instrument housing (on the rear panels).

FOR: (Desired Function)	Sweep Ramp Signal	Prevention of Band-Switching Glitches	AC Detection
CONNECT FROM:			
8003 Analyzer	SWEEP IN	BLANKING INPUT	AC MOD OUTPUT
CONNECT TO:			
Giga-tronics (12720A)	RAMP OUT	BLANK/MARKER OUT	Pulse in
Giga-tronics (7200 Series)	RAMP OUT	Neg. blank out	Pm in
Giga-tronics (910 Series)	Sweep out	Unblank/markers	Pulse in
Giga-tronics (610 Series)	Sweep out	Unblank	Pulse in
HP 8350	Sweep out	POS Z BLANK	Pulse in
HP 8340 Series and HP 8360	SWEEP OUTPUT	POS BLANK	PULSE INPUT
Marconi (6300 Series)	SWEEP o/p	SYNC o/p	PULSE i/p
Wiltron (6600B Series)	HORIZ OUTPUT	SEQ SYNC OUTPUT	EX AM INPUT
Wiltron (6700B Series)	HORIZ OUTPUT	RETRACE BLANKING o/p (SHIFT → Trigger 109)	PULSE GATE TRIG o/p

B.3.3.2 GPIB Interconnect Cable Connections

	GPIB Connector Label Out	To Set Sweeper Address
8003 Analyzer	GPIB PRIVATE	Press: CONFIG → GPIB DEVICES (softkey) → SOURCE ADRS (softkey) → 20 → GHz/dB
Giga-tronics (12720A)	GPIB	Press: CONFIG → GPIB (softkey) → 20 → GHz
Giga-tronics (7200 Series)	REMOTE	Press: SPECIAL FUNCTION → A → S_ADDR (softkey) → 20 → GHz/dB
Giga-tronics (910 & 610)	REMOTE	Rear Panel DIP Switches set to: Position: 1 2 4 8 16 Setting: 0 0 1 0 1
HP 8350 Series or HP 8360 Series	HP INTERFACE BUS	Press: SHIFT → LCL → 20 → dBm/dB
HP 8340 Series	HP INTERFACE BUS	Press: SHIFT → LOCAL → 20 → kHz/msec
Marconi 6300 Series	SYSTEM	Press: SHIFT → STATUS 2 → S_ADDR (softkey) → 20 → kHz/int
Wiltron 6600B Series	IEEE 488 INTERFACE	Rear Panel DIP Switches set to: Position: 1 2 4 8 16 Setting: 0 0 1 0 1
NOTE: If GPIB communication with the Model 8003 is not automatically established when the 8003 and the 6600B are interconnected and turned on, press the RESET key on the front of the Wiltron 6600B Series instrument.)		
Wiltron 6700B Series	IEEE 488 INTERFACE	Press: SHIFT → ADRS → 20 → ENTER

B.4 Printer Installation

The 8003 supports the following printers for generating hardcopies of displayed data and/or plots:

- HP PaintJet Printer
- HP ThinkJet Printer
- HP LaserJet Family of Printers

The installation instructions on the next 3 pages will define the necessary interconnections and address settings for each of these printers, and will also describe the RS-232 cable required when using the HP LaserJet family of printers.

B.4.1 PaintJet Color GPIB Cable Interconnections

	Instrument Connector Label	To Set Printer Address
CONNECT FROM:		
8003 Analyzer	GPIB/PRIVATE	Press: CONFIG → GPIB DEVICES → (softkey) → PRINTER ADDRESS (softkey) → 1 → GHz/dB
CONNECT TO:		
HP PaintJet Color Graphics Printer	HP-IB Connector (rear panel of printer)	Set rear panel DIP switches as shown below: <div style="text-align: center;"> </div>
NOTE: After setting the address, the printer must be turned OFF and then ON again.		

B.4.2 ThinkJet GPIB Cable Interconnections

	Instrument Connector Label	To Set Printer Address
CONNECT FROM:		
8003 Analyzer	GPIB/PRIVATE	Press: CONFIG → GPIB DEVICES → (softkey) → PRINTER ADDRESS (softkey) → 1 → GHz/dB
CONNECT TO:		
HP PaintJet Color Graphics Printer	GP-IB Connector (rear panel of printer)	Set rear panel DIP switches as shown below: <div style="text-align: center;"> </div>
NOTE: After setting the address, the printer must be turned OFF and then ON again.		

8003 Precision Scalar Analyzer

B.4.3 LaserJet Family RS-232 Cable Interconnections

	Instrument Connector Label	To Set Printer Address
CONNECT FROM:		
8003 Analyzer	RS-232 Port (rear panel female connection)	N/A – Direct Connection
CONNECT TO:		
HP LaserJet Family	RS-232	N/A – Direct Connection

B.4.3.1 RS-232 Electrical Description

M -M Cable		
Printer Connection:	Pin Number	Function
	1	FG – Frame Ground
	2	TD – Transmit data to the 8003
	3	RD – Received data from the 8003
	7	SG – Signal Ground
	20	DTR – Data Terminal Ready
8003 Connection:		
	1	FG – Frame Ground
	2	TD – Received Data from the printer
	3	RD – Transmit Data to the printer
	7	SG – Signal Ground
	20	DTR – Data Terminal Ready

Since the HP LaserJet printer is designed to operate through either RS-232 or RS-422 cable interconnections, there is a switch (SW 1- Switch 1) and a jumper (JP 2- Jumper 2) on the printer's rear panel that must be properly set. The diagrams on the next page will show the location and proper positioning of these components.



NOTE: The 8003 Analyzer operates only at a Baud rate of 9600.



NOTE: After setting the address, the printer must be turned OFF and then ON again.

B.4.4 LaserJet Printer Switch & Jumper Location and Settings

SW 1 Location and Setting

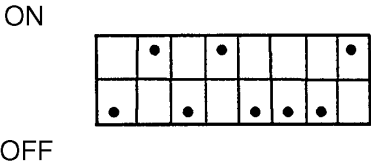
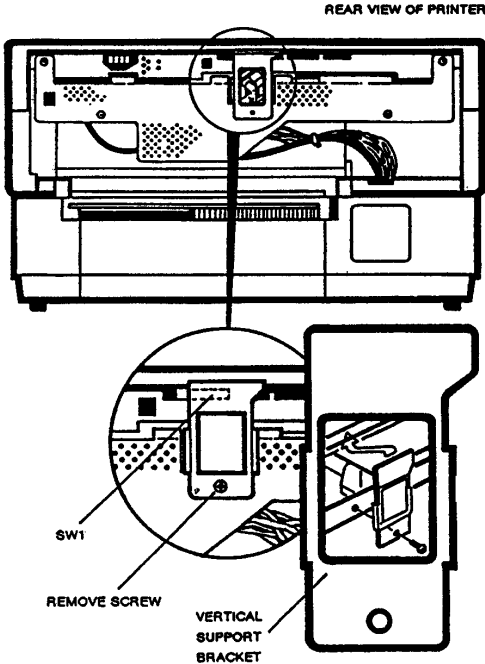

JP 2 Location and Setting:

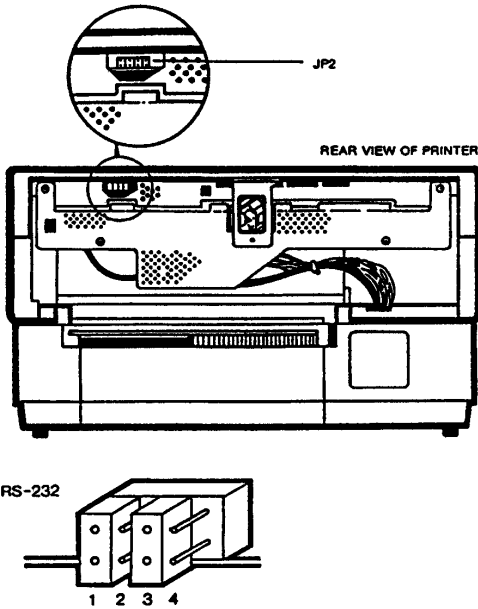

8003 Precision Scalar Analyzer

B.5 Plotter GPIB Installation Interconnections & Pen Colors

The 8003 Analyzer can plot data on most compatible GPIB plotters. The instructions given on the next 5 pages cover the plotters that are generally the most commonly used in the industry.

- HP 7550A
- HP 7440A
- HP 7475A
- HP 7470A
- HP 7090A

When you wish to connect a plotter to the analyzer, please refer to the installation instructions given for your particular plotter. Initial pen colors to correspond with the 8003's default color format are also defined.

B.5.1 HP 7550A

	Instrument Connector Label	To Set Printer Address
CONNECT FROM:		
8003 Analyzer	GPIB/PRIVATE	Press: CONFIG → GPIB DEVICES → (softkey) → PLOTTER (softkey) → 5 → GHz/dB
CONNECT TO:		
HP 7550A Plotter	HP-IB Connector	The HP 7550A should be set to its default address of 5. This can be checked by following the instructions given in the HP operating manual pertaining to HP-IB operation.

B.5.1.1 HP 7550A Pen Color Format (8 Pens)

(When pens are formatted as follows, the colors will correspond to the 8003's default display.)

Pen Number	Color	Displayed Function
1	Black	Giga-tronics Logo
2	Red	Channel 2
3	Yellow	Channel 3
4	Green	Grid, Title, Channel Title, and Frequency
5	Cyan	Channel 1
6	Blue	Not Used
7	Magenta	Channel 4
8	Not Used	

B.5.2 HP 7440A

	Instrument Connector Label	To Set Printer Address
CONNECT FROM:		
8003 Analyzer	GPIB/PRIVATE	Press: CONFIG → GPIB DEVICES → (softkey) → PLOTTER (softkey) → 5 → GHz/dB
CONNECT TO:		
HP 7440A Plotter	HP-IB Connector	Set rear panel DIP switches as shown below: <div style="text-align: center;"> </div>

B.5.2.1 HP 7440A Pen Color Format (8 Pens)

(When pens are formatted as follows, the colors will correspond to the 8003's default display.)

Pen Number	Color	Displayed Function
1	Black	Giga-tronics Logo
2	Red	Channel 2
3	Yellow	Channel 3
4	Green	Grid, Title, Channel Title, and Frequency
5	Cyan	Channel 1
6	Blue	Not Used
7	Magenta	Channel 4
8	Not Used	



NOTE: After setting the address, the plotter must be turned OFF and then ON again.

8003 Precision Scalar Analyzer

B.5.3 HP 7475A

	Instrument Connector Label	To Set Printer Address
CONNECT FROM:		
8003 Analyzer	GPIB/PRIVATE	Press: CONFIG → GPIB DEVICES → (softkey) → PLOTTER (softkey) → 5 → GHz/dB
CONNECT TO:		
HP 7475A Plotter	HP-IB Connector	Set rear panel DIP switches as shown below:

B.5.3.1 HP 7475A Pen Color Format (6 Pens)

(When pens are formatted as follows, the colors will correspond to the 8003's default display.)

Pen Number	Color	Displayed Function
1	Black	Giga-tronics Logo
2	Red	Channel 2
3	Yellow	Channel 3
4	Green	Grid, Title, Channel Title, and Frequency
5	Cyan	Channel 1
6	Blue	Not Used



NOTE: After setting the address, the plotter must be turned OFF and then ON again.

B.5.4 HP 7470A

	Instrument Connector Label	To Set Printer Address
CONNECT FROM:		
8003 Analyzer	GPIB/PRIVATE	Press: CONFIG → GPIB DEVICES → (softkey) → PLOTTER (softkey) → 5 → GHz/dB
CONNECT TO:		
HP 7475A Plotter	HP-IB Connector	Set rear panel DIP switches as shown below: <div style="text-align: center;"> </div>

B.5.4.1 HP 7470A Pen Color Format (2 Pens)

(When pens are formatted as follows, the colors will correspond to the 8003's default display.)

Pen Number	Color	Displayed Function
1	Black	Giga-tronics Logo, Channel 1, Channel 3, Channel 4
2	Red	Channel 2, Grid, Title, Channel Title and Frequency



NOTE: After setting the address, the plot must be turned OFF and then ON again.

8003 Precision Scalar Analyzer

B.5.5 HP 7090A

	Instrument Connector Label	To Set Printer Address
CONNECT FROM:		
8003 Analyzer	GPIB/PRIVATE	Press: CONFIG → GPIB DEVICES → (softkey) → PLOTTER (softkey) → 5 → GHz/dB
CONNECT TO:		
HP 7090A Plotter	HP-IB Connector	Set rear panel DIP switches as shown below:

B.5.5.1 HP 7090A Pen Color Format (6 Pens)

(When pens are formatted as follows, the colors will correspond to the 8003's default display.)

Pen Number	Color	Displayed Function
1	Black	Giga-tronics Logo, Channel
2	Red	Channel 2
3	Yellow	Channel 3
4	Green	Grid, Title, Channel Title and Frequency
5	Cyan	Channel 1
6	Blue	Not Used



NOTE: After setting the address, the plotter must be turned OFF and then ON again.

B.6 Connecting Analyzer to an Instrument Controller

The 8003 Analyzer can be remotely controlled via the GPIB (IEEE 488) bus. To connect the 8003 Analyzer to an IEEE 488 compatible Instrument Controller, use the GPIB connection marked "GPIB/SYSTEM" on the rear panel of the analyzer.



NOTE: This is a different GPIB connector than the "GPIB/PRIVATE" connection used for sweeper, plotter and printer control.

Be sure that the remote controller is connected only to the GPIB/SYSTEM connection as it will not function if connected to the "PRIVATE" interface.

For further information see the installation and address setting instructions given on page 3-1 of Chapter 3, REMOTE OPERATION.

8003 Precision Scalar Analyzer Index

Symbols

*ESR? 3-20
*IDN? 3-23

Numerics

8003 Default Settings B-1
8003 Features 1-1
8003 GPIB Commands 3-8
8003 Introduction
 8003 Features 1-1
 Description 1-1
8003 Power Sweep Measurements 2-104
8003 System B-3
 Sweeper Installation B-4

A

About This Manual ix
Absolute Power & Swept Capabilities 2-13
AC Mode Output Connector Check 4-12
Accuracy 1-9
 Absolute Power Measurement Accuracy 1-11
 Cal Factor Correction 1-12
 Instrument plus Power Sensor Linearity 1-11
 Noise Uncertainty 1-12
 Reflection Accuracy = Scalar Accuracy+ Reflection Bridge Accuracy 1-10
 Transmission Accuracy = Instrument Accuracy + Mismatch Uncertainty 1-9
 Transmission Loss or Gain Measurements 1-9
 Zeroing Accuracy 1-12
Accurate Range Measurements 2-102
ALL SWEPT and ALL CW Softkeys 2-21
AVG Softkey
 AVG N 2-24
 AVG ON/OFF 2-24
 SMOOTH APERT 2-25
 SMOOTH ON/OFF 2-25
 SMOOTHING 2-24

B

Bandwidth Searches 2-91
Bias Output Connector Check 4-12
BIAS, BV 3-12

C

CAL 3-12
Cal Factor Corrections CW Mode 2-99
CAL Key 2-36
 CAL SENSOR Softkey 2-38
 CLR PTH CAL Softkey 2-37
 SHORT/OPEN Softkey 2-36
 THRU Softkey 2-37
 ZERO SENSOR Softkey 2-39
CAL SENSOR Softkey
 CAL ALL 2-38
 SENSOR A, B, or C CAL 2-38

CAL SWP RAMP Softkey
 STANDARD 2-61
 V_{PROP}F 2-61
Calibrating for Power Measurement 2-67
Calibrator Frequency Check 4-5
Calibrator Output Power Reference Level 4-3
Calibrator Verification Procedure 4-3
Case Insensitivity
 Command Execution 3-10
CHAN, CH 3-13
Channel & Function Selection 2-12
CHANNEL Controls 2-15
 DEFINE Key 2-15
 OFF Key 2-15
Channel Titles 2-8
Cleaning 1-6
CLEAR N Softkey
 CLEAR ALL MEM 2-49
 CLEAR ALL N 2-49
 CLEAR N 2-49
Command Execution
 ds Definition 3-10
 EOL Definition 3-10
 hs Definition 3-10
 us Definition 3-10
Common Structure 3-7
CONFIG Key
 CAL SWP RAMP Softkey 2-61
 CORRECTN OFF Softkey 2-60
 CW CAL FACTOR Softkey 2-60
 CW FREQ Softkey 2-59
 FROM SOURCE Softkey 2-60
 GPIB DEVICES Softkey 2-60
 PULSE SENSORS Softkey 2-60
 SENSOR OFFSET Softkey 2-60
 SENSORS AC/DC Softkey 2-57
 SENSORS CW FREQ Softkey 2-57
 SERVICE Softkey 2-61
Connecting Analyzer to an Instrument Controller B-15
Conventions xi
Cooling 1-6
Cursor Delta (Δ) Functions 2-92
Cursor Frequency 2-8
CURSOR Key 2-40
 CURSOR Δ ON/OFF Softkey 2-41
 CURSOR FREQ Softkey 2-40
 CURSOR ON/OFF Softkey 2-40
 CURSR → MRKR N Softkey 2-44
 DEFINE MRKR N Softkey 2-45
 SEARCH Softkey 2-43
CURSOR, CUR 3-14
Cursors & Markers 1-8, 2-87
Cursors on Multiple Channels 2-93
Custom Modifiers
 3-34
CW Power Measurement Command Structure 3-36
CW Power Measurements 2-98

D

DAC Output Connector Check 4-13
DEFINE Key
 A-, B-, C- 2-16
 A, B, or C 2-15
 A/, B/, C/ 2-15
 BIAS VOLTAGE Softkey 2-16
 CW/SWEPT Softkey 2-16
 DIFF Softkey 2-16
 RATIO Softkey 2-15
 SINGLE SENSOR Softkey 2-15

8003 Precision Scalar Analyzers

DEFINE MRKR N Softkey
 CLEAR ALL MRKRS 2-46
 CLEAR MRKR N 2-46
 CURSOR FREQ 2-45
 DEFINE MRKR N 2-45
 MRKR N ON and MRKR N OFF 2-45
Definition of ASCII Codes 3-26
Description 1-1
Device Clear
 Channel, Cursor, Sensor, Display, Channel, Source 3-18
Directional Bridges A-4
DISABLE 3-19
Display 3-18
Display Description 2-8
 Channel Titles 2-8
 Cursor Frequency 2-8
 Front Panel Function Key/Remote Light 2-8
 Softkey Labels 2-8
 Start, Center, CW Frequency 2-9
 Stop, Span 2-8
DISPLAY Key 2-24
 AVG Softkey 2-24
 DISPLAY SETUP Softkey 2-33
 GRAPH/READOUT Softkey 2-32
 HOLD ON/OFF Softkey 2-26
 LIMIT LINES Softkey 2-31
 PLOT & PRINT Softkey 2-27
 UNITS Softkey 2-32
DISPLAY SETUP Softkey
 ALPHA/CURS POS 2-34
 CH TTL ON/OFF 2-34
 CHANNEL COLOR 2-33
 COLOR 2-33
 FREQ LBL ON/OFF 2-34
 GRAT COLOR 2-33
 LABELS 2-33
 TITLE 2-34
 TITLE ON/OFF 2-34
 UNDO/ERR TTL 2-34
DISPLAY STATUS Softkey
 DISPLAY CURRENT and DISPLAY PREV 2-48
 DISPLAY N 2-48
ds Definition 3-10

E

ENABLE 3-19
Environmental Requirements 1-5
EOL Definition 3-10
Equipment Required 4-6

F

FIXED 3-21
Front & Rear Panel Descriptions 2-1
Front Panel Function Key/Remote Light 2-8
Front Panel Operation (Instructions) 2-66
THRU Softkey 2-37
FUNCTION Controls 2-18
 MEAS Key 2-18
 SCALE Key 2-22

G

General 4-1
 GPIB Interconnect Cable Connections B-5
 GPIB Interface 1-13
 GPIB Port Check 4-10
 GPIB Private Port Check 4-11
 GPIB/PRIVATE Interface
 Pass Through Feature 3-72
 GPIB/Private Port Check 4-11
 GPIB/System Port Check 4-10
 Graph & Readout Display Modes 2-13

H

Hints on Simplified Scaling 2-86
HP 7090A
 HP 7090A Pen Color Format (6 Pens) B-14
HP 7440A
 HP 7440A Pen Color Format (8 Pens) B-11
HP 7470A
 HP 7470A Pen Color Format (2 Pens) B-13
HP 7475A B-12
 HP 7475A Pen Color Format (6 Pens) B-12
HP 7550A
 HP 7550A Pen Color Format (8 Pens) B-10
HP Printer Installation
 LaserJet Family RS-232 Cable Interconnections B-8
 PaintJet Color GPIB Cable Interconnections B-7
 ThinkJet GPIB Cable Interconnections B-7
hs Definition 3-10

I

IEEE Bus Interface
 Connect the System Controller 3-1
 Set the GPIB Address 3-1
INPUT 3-24
Insertion & Return Loss Measurements 2-75
Installation 1-2
 Cleaning 1-6
 Cooling 1-6
 Environmental Requirements 1-5
 Items Furnished 1-5
 Items Required 1-6
 Power Input, Fuse & Voltage Selector 1-3
 Power Requirements 1-4
 Power Sensor Precautions 1-3
 Receiving Inspection 1-6
 Safety 1-2
 Tools & Test Equipment 1-6
Instrument Plus Power Sensor Linearity 4-7
 Setup Parameters 4-8
 Test Description 4-7
 Test Procedure 4-10, 4-11
Introduction
 Operation 2-1
 Remote Operation 3-1
 System Configuration B-1
Items Furnished 1-5
Items Required 1-6

K

Key Operation
 START Key 2-52
 STOP Key 2-53
KEYEM, KE 3-25

L

LaserJet Family RS-232 Cable Interconnections B-8
 RS-232 Electrical Description B-8
LaserJet Printer Swtch. & Jmpr. Loc. and Sts. B-9
LIMIT LINES Softkey 2-31
 ABORT PLOT 2-31
 CLEAR ALL SEGMENTS 2-31
 DEFINE SEGMENT 2-31
 LMT LNS ON/OFF 2-31
 PLOT ENTRIES 2-31
 SEGMENT N CLEAR 2-31
Line Voltage & Fuse Selection 1-3
 Power Sensors 1-3
 Power Sensors Accessories 1-3
Line Voltage and Fuse Selection 1-3

M

Making a Device Measurement 2-73
 Markers 2-94
 MAXHOLD and MINHOLD ON/OFF Softkey 2-21
 FUNCTION Controls 2-18
 MEAS Key
 ABS PWR PATHCAL Softkey 2-19
 CW OPTION Softkey 2-21
 TRACE MEMORY Softkey 2-19
 Measurement Modes 2-102
 CW Mode 2-102
 Swept Mode with AC Detection 2-103
 Swept Mode with DC Detection 2-103
 Measurement Query Command Structure 3-30
 MEMORY Key 2-47
 CLEAR N Softkey 2-49
 DISPLAY STATUS Softkey 2-48
 PREV STATE Softkey 2-47
 RECALL N Softkey 2-47
 STORE N Softkey 2-47
 Min & Max Search 2-87
 Mixed Mode Measurements 2-98
 Mods. Spec. to 8034XA Series Peak Sensors Only 3-51

O

OFF 2-15
 Operation 2-1
 Other CW Functions 2-100
 Output Power Reference Level 4-3
 OUTPUT, OP 3-30

P

PaintJet Color GPIB Cable Interconnections B-7
 Path Calibration Correction for Component Variations 2-69
 Frequency Response Correction 2-70
 Set Up Sweep Parameters 2-69
 Path Calibration Memory 2-13
 Performance Verification
 Calibrator Procedure 4-3
 Frequency Check 4-5
 GPIB/Private Port Check 4-11
 GPIB/System Port Check 4-10
 Instrument Plus Power Sensor Linearity 4-7
 Output Power Reference Level 4-3
 Performance Verification Tests 4-6
 Performance Verification Tests 4-6
 PLOT 3-33
 PLOT & PRINT Softkey 2-27
 ABORT PLOT 2-30
 ABORT PRINT 2-28
 DEFINE CUSTOM 2-29
 DEFINE TRACE 2-29
 ED LOGO 2-30
 INK PRINT 2-28
 LASER PRINT 2-28
 PAINT PRINT 2-28
 PLOT 4 2-28
 PLOT ALL 2-27
 PLOT CUSTOM 2-29
 PRINT 2-28
 SC P1P2 2-29
 SPECIAL PLOT 2-29
 Plotter GPIB Install. Interconnections & Pen Colors B-10
 Plotter GPIB Installation Interconnections & Pen Colors
 HP 7090A B-14
 HP 7440A B-11
 HP 7470A B-13
 HP 7550A B-10
 POWER 3-36
 Power Input, Fuse & Voltage Selector 1-3
 POWER Key 2-54
 POWER Function Key 2-54

 POWER Softkey 2-54
 Power Measurements 2-95
 Power On 2-14
 Power Requirements 1-4
 Standard Voltage Selector & Fuse Holder 1-5
 VDE Type Voltage Selector & Fuse Holder 1-5
 Power Sensor Precautions 1-3
 Power Sensor Selection A-1
 Power Sensors 1-3
 Directional Bridges A-4
 Introduction A-1
 Power Sensor Selection A-1
 Selection Charts A-2
 Power Sensors Accessories 1-3
 POWER Softkey
 ANALOG/DIGITAL 2-55
 FREQ 2-55
 POWER SWEEP 2-55
 PWR SWP ON/OFF 2-55
 RF POWER ON/OFF 2-54
 START POWER 2-55
 STEP SIZE 2-55
 STOP POWER 2-55
 SWEEP TIME 2-55
 Sweep Time 2-55
 Preparation for Reshipment 1-6
 Printer Installation B-6
 LaserJet Printer Swtch. & Jumper Loc. and Sts. B-9
 Programming the 8003
 Typical HP-Basic Prg. - Stepped CW Measurements 3-6
 Typical HP-Basic Prg. - Swept Measurements 3-5
 Typical TBASIC Prg. - Stepped CW Measurements 3-4
 Typical TBASIC Prg. - Swept Measurements 3-3

R

Rear Panel Inputs & Outputs 1-14
 Rear Panel Operation
 GPIB Address Selection 2-7
 Receiving Inspection 1-6
 Record of Manual Changes xiii
 CURSOR Key 2-46
 REF LEVEL Softkey 2-23
 REF → CURSOR 2-23
 REF → MAX 2-23
 REF LEVEL - F2-1 2-23
 Reflection Measurements 1-10
 REL ON/OFF Softkey 2-21
 RGB Video Output Connector Check 4-13
 RS-232 Electrical Description B-8

S

Safety Precautions 1-2
 SCALE Key 2-22
 AUTOSCALE Softkey 2-22
 CONT AUTOSCL Softkey 2-22
 REF LEVEL Softkey 2-23
 REF POS Softkey 2-22
 SCALE FACTOR Softkey 2-22
 Scaling the Display 2-84
 Search Functions Using the Cursor 2-87
 SEARCH Softkey
 BANDWIDTH (BW) 2-43
 FLATNESS 2-44
 MAX and MIN 2-44
 SEARCH LEFT and SEARCH RIGHT 2-43
 SEARCH VALUE 2-43
 Searches on Frequency Selective Devices 2-89
 Sensor Definition Command Structure 3-51
 Sensor Offsets 2-100
 Sensors & Sensor Calibration 2-12
 Serial Port Check 4-10

8003 Precision Scalar Analyzers

- SERVICE Softkey 2-61
 - ABORT 2-62, 2-65
 - CAL LOC 2-64
 - CHANGE COLOR 2-63
 - CIRCLES and 1 COLOR 2-63
 - CLEAR PASSWORD 2-62, 2-65
 - COLOR BARS 2-63
 - DEFINE PASSWORD 2-62, 2-64
 - DONE 2-62, 2-63
 - ENABLE INPUT 2-64, 2-65
 - FIRST PAGE and LAST PAGE 2-64
 - GRID L/S and DOTS L/S 2-63
 - PAGE UP 2-64
 - PAGE UP and PAGE DOWN 2-64
 - PASSWORD 2-64
 - PROGRAM EEPROM 2-65
 - SENSOR EEPROM 2-63
 - SET CAL 2-61
 - SET CAL OUTPUT 2-61
 - SET CAL S/N 2-61
 - SET TIME 2-62, 2-64
 - TEST PATTERN 2-63
- Set the GPIB Address
 - Programming the 8003 3-2
- SHORT/OPEN Softkey
 - FULL BAND A, B, or C Y/N 2-37
 - STORE SHORT A, B, or C 2-36
- Signal Sources 1-15
- SINGLE SENSOR Softkey 2-15
- Single-Sensor Insertion Loss Measurement 2-75
- Single-Sensor Return Loss Measurements 2-79
- Single-Sensor vs Two-Sensor Measurements 2-78
- Softkey 2-46
- Softkey Functional Description 2-12
 - Absolute Power & Swept Capabilities 2-13
 - Channel & Function Selection 2-12
 - Graph & Readout Display Modes 2-13
 - Path Calibration Memory 2-13
 - Power On 2-14
 - Sensors & Sensor Calibration 2-12
 - Softkey Labels & Color Indications 2-12
 - Trace Memory 2-14
- Softkey Labels 2-8
- Softkey Labels & Color Indications 2-12
- SOURCE Controls 2-51
 - 8003 Source Compatibility 2-51
 - ATE Operation 2-51
 - General Description 2-51
 - Key Operation 2-52
 - UPD SWP ON/OFF 2-52
- Span Swept Freq. Source Mode Def. Cmd. Structure 3-67
- Special Configurations xv
- Specifications 1-7
 - Accuracy 1-9
 - Cursors & Markers 1-8
- START Key
 - START, CENTER, and CW 2-52
- Start, Center, CW Frequency 2-9
- STOP Key
 - STOP, DF and CW 2-53
- Stop, Span 2-8
- Structured GPIB Language 3-7
 - Channel Bias Voltage Definition Command Structure
 - BIAS 3-12
 - Channel Definition Command Structure
 - CHAN, CH 3-13
 - Command Execution 3-10
 - Common Structure 3-7
 - Cursor Definition Command Structure
 - CURSOR, CUR 3-14
 - CW Power Measurement Command Structure
 - POWER 3-36
 - Fast Step CW Meas. Mode Prg. Example 3-48
 - Fast-CW Mode Programming Example 3-43
 - TTL-Triggered Fast-CW Mode Prg. Expl. 3-47
 - Disable Private Bus Command Structure
 - DISABLE 3-19
 - External Status Register Query Command Structure
 - *ESR? 3-20
 - Fixed Frequency Source Mode Definition Command Structure
 - FIXED 3-21
 - GPIB/PRIVATE Interface 3-71
 - Graph Display Definition Command Structure
 - GRAPH, GPH 3-23
 - IEEE GPIB Interface Characteristics 3-11
 - Input Command Structure
 - INPUT 3-24
 - Instrument Identifier Command Structure
 - *IDN? 3-23
 - Instrument Preset Command Structure
 - 3-18
 - Key Stroke Emulation Enable/Disable Command Structure
 - KEYEM, KE 3-25
 - Definition of ASCII Codes 3-26
 - Memory Command Structure
 - MEMORY 3-29
 - Plot Command Structure
 - PLOT 3-33
 - Plotter Command Programming Example 3-35
 - Print Definition Command Structure
 - PRINT 3-49
 - Readout Display Definition Command Structure
 - READOUT, TEXT, TXT 3-50
 - Sensor Calibration Command Structure
 - CAL 3-12
 - Sensor Definition Command Structure
 - SENSOR, SEN 3-51
 - Sensor Path Calibration Command Structure
 - THRU, PATH 3-69
 - Sensor Short/Open Calibration Command Structure
 - SHORT 3-53
 - Sensor Zeroing Command Structure
 - ZERO 3-70
 - Span Swept Frequency Source Mode Definition Command Structure
 - SWPS 3-67
 - Start/Stop Swept Frequency Source Mode Definition Command Structure
 - SWPF 3-64
 - Update Command Programming Example 3-66
 - STATUS MESSAGES
 - 488.2 External Status 3-71
 - 488.2 Status Byte 3-70
 - Swept Measurement Command Structure 3-54
 - SWP, SWP?
 - Limit Line Programming Example 3-63
 - Trace Memory Programming Example 3-61
 - Temperature & Low Level Offset Update Structure
 - RDTEMP 3-49
- Structured GPIB Language Enable Private Bus Command Structure
 - ENABLE 3-19
- Sweep in Connector Check 4-11
- SWEEP TIME Key 2-56
 - SWEEP TIME Softkey 2-56
- SWEEP TIME Softkey
 - INT SWP TRIGGER 2-56
- Sweeper Installation B-4
 - GPIB Interconnect Cable Connections B-5
- Swept Measurement Command Structure 3-54
 - SWP, SWP? 3-54
- SWPF 3-64
- SWPS 3-67
- System Configuration
 - 8003 Default Settings B-1
 - 8003 System B-3
 - Connecting Analyzer to an Instrument Controller B-15
 - Plotter GPIB Install. Interconnection & Pen Colors B-10
 - Printer Installation B-6
- SYSTEM Controls 2-57
 - CONFIG Key 2-57
 - PRESET Key 2-57

T

Temperature & Low Level Offset Update Structure 3-49
Temperature Stability 2-102
ThinkJet GPIB Cable Interconnections B-7
Three-Sensor Configurations 2-82
THRU, PATH 3-69
Tools and Test Equipment 1-6
Trace Memory 2-14, 2-82
Two-Sensor Insertion Loss Measurements 2-77
 Single-Sensor vs Two-Sensor Measurements 2-78
Two-Sensor Return Loss Measurements 2-81

U

UNITS Softkey 2-32
us Definition 3-10
Using Channels 2-76
Using the Cursor to Set the Reference Level 2-86

Z

ZERO 3-70
ZERO SENSOR Softkey 2-39
 ZERO ALL and SENSOR (A, B, and C) 2-39

