

Agilent 4294A Precision Impedance Analyzer 40 Hz to 110 MHz

Technical Overview

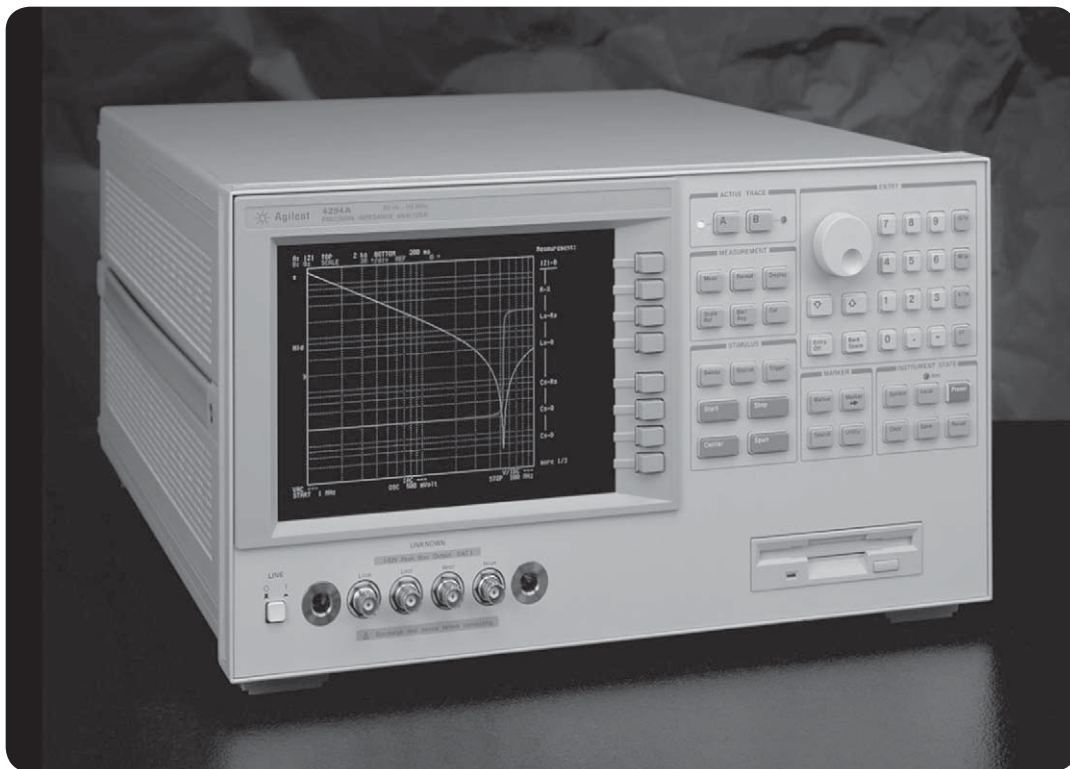
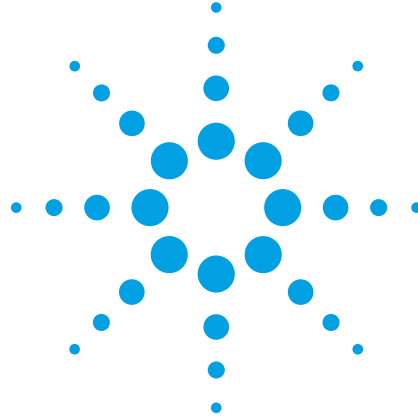

New generation precision impedance analyzer for functionality and efficiency in engineering

Agilent 4294A Precision Impedance Analyzer

The Agilent Technologies 4294A precision impedance analyzer greatly supports accurate impedance measurement and analysis of a

wide variety of electronic devices (components and circuits) as well as electronic and non-electronic material.

- Accurate measurement over wide impedance range and wide frequency range
- Powerful impedance analysis functions
- Ease of use and versatile PC connectivity

8.5 inch TFT color display. Powerful analysis tools available. 801 sweep points, 4 traces (2 data traces and 2 memory traces), 8 markers, marker analysis functions, and equivalent circuit analysis function.

User-friendly interface. Based on Agilent's widely accepted user-interface.

Rigid fixture/accessory connection. Provides highly repeatable and reliable measurements.

IBASIC programming function. Automatic set up, measurement, and computation as well as remote instrument control is possible.

Built-in 10 Mbyte nonvolatile memory. Data or setup files can be quickly saved or recalled.

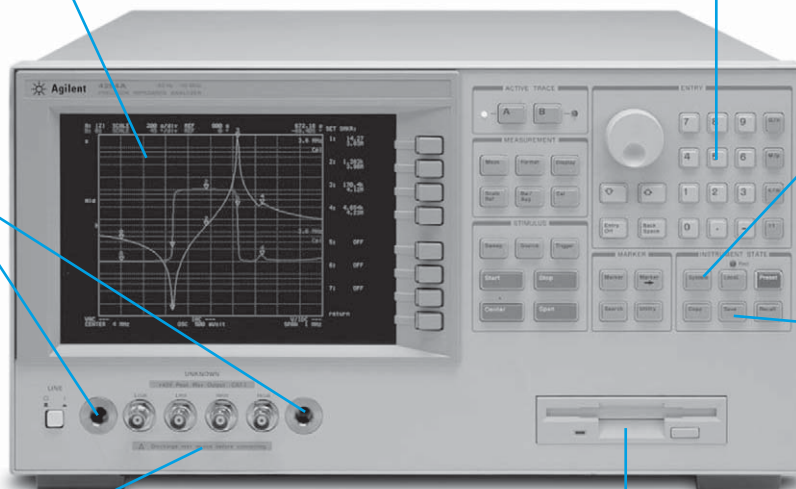

Impedance measurement ports. Four-terminal-pair measurement configuration and the newest auto-balancing bridge technique enable high accuracy and wide impedance range.

3.5 inch floppy disk drive. Screen images, data and setup files can be easily saved, recalled, and shared (1.44 Mbyte).

Two digital I/O ports.

Control other instrument(s) or use an external controller (instrument or computer) via 8 bit or 24 bit programmable I/O port.

External VGA Output.

Display measurements on a large VGA monitor. Reduces eyestrain, improves team work and communication.

LAN Interface (10 Base-T)

Another instrument control method or simplified file sharing.

GPIB Interface. Automatic measurement system is easily configured with an external instrument or computer.

External keyboard Interface. Makes IBASIC program development easier (mini DIN keyboard).

Printer (Centronics) Interface. Connects PCL3 printers directly to the instrument.

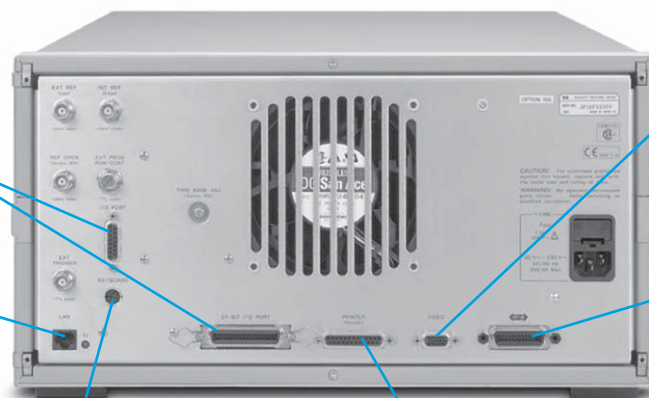

40 Hz to 110 MHz

The Agilent 4294A is a powerful tool for design, qualification, quality control, and production testing of electronic components. Circuit designers and developers can also benefit from the performance/functionality offered.

Moreover, the 4294A's high measurement performance and capable functionality delivers a powerful tool to circuit design and development as well as materials research and development (both electronic and non-electronic materials) environments.

The following are application examples:

Electronic devices

Passive component

- Impedance measurement of two terminal components such as capacitors, inductors, ferrite beads, resistors, transformers, crystal/ceramic resonators, multi-chip modules or array/network components.

Semiconductor components

- C-V characteristic analysis of varactor diodes.
- Parasitic analysis of a diode, transistor, or IC package terminal/leads.
- Amplifier input/output impedance measurement.

Other components

- Impedance evaluation of printed circuit boards, relays, switches, cables, batteries, etc.

Materials

Dielectric material

- Permittivity and loss tangent evaluation of plastics, ceramics, printed circuit boards, and other dielectric materials.

Magnetic material

- Permeability and loss tangent evaluation of ferrite, amorphous, and other magnetic materials.

Semiconductor material

Permittivity, conductivity, and C-V characterization of semiconductor materials.

Agilent 4294A key specifications

Operating frequency	40 Hz to 110 MHz, 1 MHz resolution
Basic impedance accuracy	±0.08%
Q accuracy	±3% (typical) @ Q = 100, f ≤ 10 MHz
Impedance range	3 mΩ to 500 MΩ ^{*1}
Measurement time	3 msec/point @ f ≥ 500 kHz, BW = 1 (fast)
Number of points per sweep	2 to 801 points
Measurement type	Four-terminal-pair measurement (standard) 7-mm one port measurement (with the 42942A) measurable grounded devices Impedance probe measurement (with the 42941A) measurable grounded devices
Impedance parameters	IZI, IYI, θ, R, X, G, B, L, C, D, Q
DC bias	0 to ±40 V/100 mA, 1 mV/40 μA resolution Constant voltage/constant current mode, DC bias V/I monitor function
OSC level	5 mV to 1 Vrms/200 μA to 20 mArms OSC level V/I monitor function
Sweep parameter	Frequency, OSC level (V/I), DC bias (V/I)
Sweep type	Linear, log, list; manual sweep mode: up/down sweep
Other function	Equivalent circuit analysis function, Limit line function Trace accumulate mode
Marker	Eight markers (one main marker and seven sub markers) Delta marker function, marker search function (Max, Min, Peak, Next peak, etc.) Marker analysis function

(*1) 30% typical accuracy range: 3 mΩ (100 Hz to 110 MHz), 500 MΩ (100 Hz to 200 kHz)

Accurate, Real-World Characterization of Electronic Components

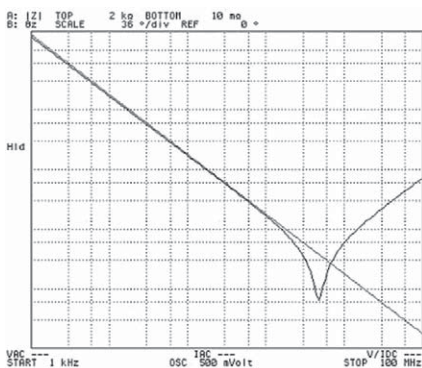
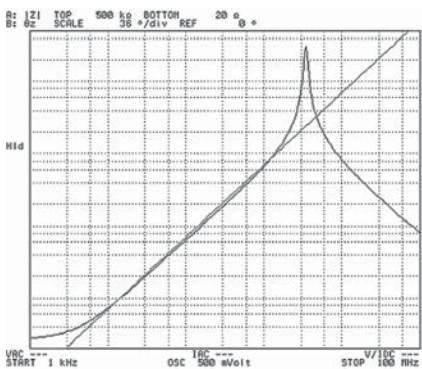

There is no ideal inductor (L), capacitor (C), or resistor (R). In reality, operating conditions such as signal level and frequency determine the real-world performance of a device based on the electronic characteristics of the device. An ideal component of high quality could be considered to possess a single, perfect circuit element over some frequency range. However, in reality, most components will resonate as shown in these figures as the frequency increases.

This is due to the fact that there are both capacitive and inductive elements present in real world components. Component characteristics cannot be expressed correctly with a two-element model when the model contains only one single reactive element. The Agilent 4294A equivalent circuit function enables modeling of the impedance vs. frequency characteristics with three or four elements. This function helps you design quality circuits and effective components.

Equivalent circuit analysis

The equivalent circuit function is used to fit a circuit model to measured data, or to simulate device performance based on the value of each circuit model element.

The 4294A has been programmed with five equivalent circuit models to choose from. This function automatically extracts equivalent circuit parameters from actual measurement data. The characteristics of the device under test (DUT) or the material under test (MUT) can be analyzed with extracted model element values.

NOTE: The simulation result and the actual measurement data can be displayed on the same screen.

Step 1.

After taking a measurement,

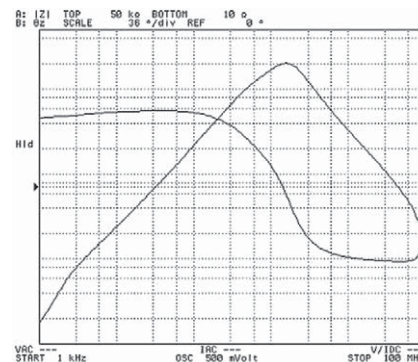

Step 2.

select an appropriate circuit model

EQUIVALENT CIRCUIT MODEL

SELECTED: A

A	B	C

R1: 17.652 kΩ C1: 4.4453 pF
L1: 3.3 nH

Step 3.

and extract the circuit model parameters.

Step 4.

Then compare the simulation to the actual measurement data. If the data does not match, select a different equivalent circuit model and try again.

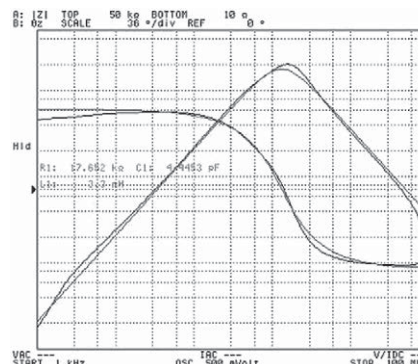

State-of-the-art technology for improved measurement performance

The Agilent 4294A employs a state-of-the-art auto-balancing-bridge technique in a four-terminal-pair (4TP) measurement configuration. Meticulous circuit design against distortion and instability resulted in a highly accurate and stable measurement system for a wide impedance range.

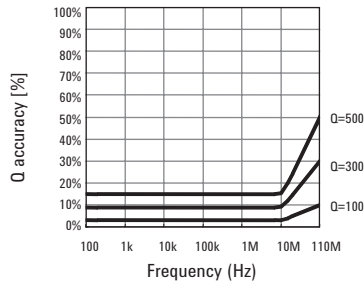

4294A Q accuracy (typical)
OSC level = 250 mV

For evaluation of low-loss devices

With the trend toward lower power consumption and compact equipment, inductors and capacitors are becoming smaller with lower loss. The efficiency

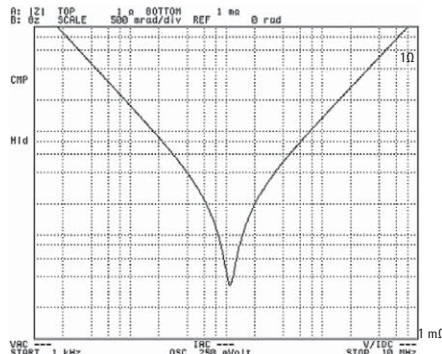

Low-loss capacitor ESR (equivalent series resistance) measurement (100 μ F ceramic C)

improvement in power conversion for switching power supply applications is an example. These applications require low-loss inductors and capacitors.

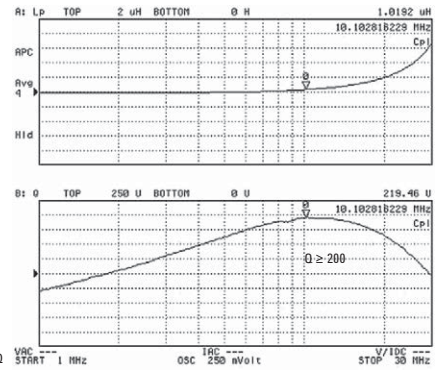

High Q inductor measurement (low-loss)

For evaluating devices with wide impedance range

A wide impedance range is required to accurately measure both resonant impedance and anti-resonant impedance of crystal/ceramic resonators.

The 4294A covering several decades (m Ω to hundreds of M Ω) of impedance can measure resonator characteristics accurately.

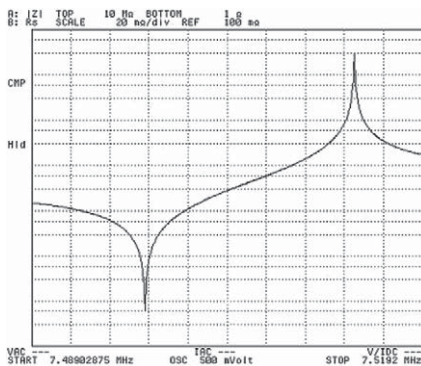

Crystal resonator impedance measurement

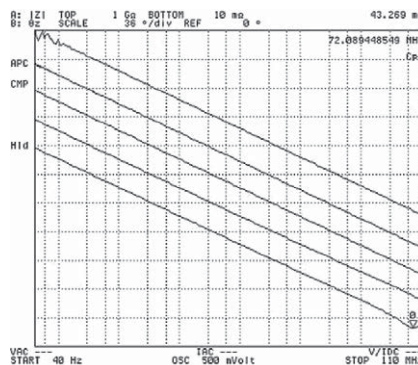

SMD capacitor impedance measurement (using the 42942A)

The dynamic range of the 4294A in terms of impedance is more than 200 dB. When compared to that of a general network analyzer with a directional bridge, at 80 dB, it is clear, the 4294A has an extremely broad impedance-measurement range.

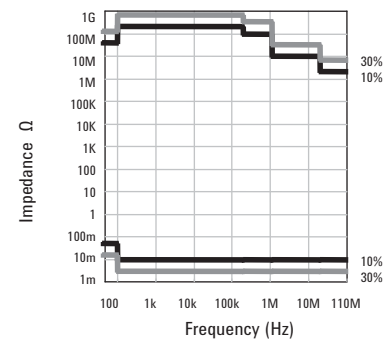

Impedance measurement range (typical)

Impedance Analysis Under Various Operating Conditions

Signal level dependency

The impedance characteristics of some devices change drastically as a function of the signal level. The Agilent 4294A can sweep test signal voltage, 5 mVrms to 1 Vrms (1 mV resolution), or test signal current 200 μ Arms to 20 mArms (20 μ A resolution) to evaluate signal level dependency.

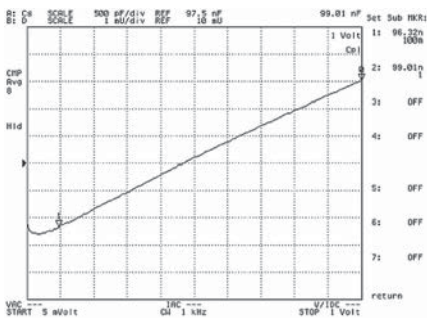

Signal level dependency of a ceramic capacitor with high permittivity (signal-level swept from 5 mV to 1 V, 0.1 μ F capacitor at 1 kHz)

DC level dependency

The DC component of an applied signal often affects device impedance. The 4294A can sweep either the DC voltage bias from -40 V to +40 V (with 1 mV resolution) or the DC current bias from -100 mA to +100 mA (with 40 μ A resolution) to evaluate DC signal dependency. This capability also empowers analysis of the DC-voltage bias dependency for C-V characterization of varactor diodes or other DC-voltage bias dependent devices. The DC level dependency figure shows an example of varactor diode measurement.

The DC bias auto level control (ALC) function, based on a feedback loop technique, accurately maintains the applied DC voltage bias or current bias. While the impedance of a device might change during a sweep, this ALC function insures that the signal level setting is the actual signal level applied to the DUT.

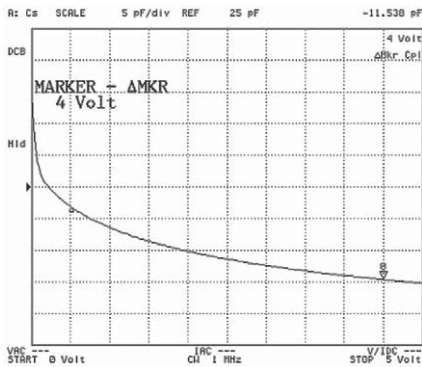

Varactor diode capacitance vs. DC voltage characteristic. DC bias sweep from 0 V DC to 5 V DC, $f = 1$ MHz

Efficient analysis with the list sweep function

The list sweep function enables different measurement setups in a single sweep by dividing the sweep range into segments. The measurement setup, including the frequency range, averaging time, measurement bandwidth, test signal level (V or A), and DC bias can be different for each segment. The frequency range of each segment can be continuous, separated, or overlapped.

Evaluation of a crystal resonator requires that the nominal resonant frequency, the nominal anti-resonant frequency, and some spurious frequencies be determined. These parameters can be efficiently measured by setting an appropriate frequency range for each segment.

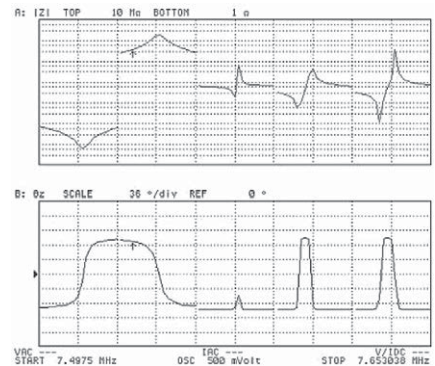

Crystal resonator evaluation by list sweep function

SEG	START	STOP	NOP	OSC	BIAS	BW	AVG
1	7.4975MHz	7.498MHz	21	500mV	0V	5	1
2	7.51355MHz	7.51405MHz	20	500mV	0V	5	1
3	7.53963MHz	7.54963MHz	20	500mV	0V	3	1
4	7.60035MHz	7.61035MHz	20	500mV	0V	3	1
> 5	7.64304MHz	7.65304MHz	20	500mV	0V	3	1

Edit screen of list sweep

Powerful functions for efficient evaluation

Sweep, display, and markers

Up sweep/down sweep
Control the sweep direction. Sweep frequency, test signal level, or DC bias from lower to higher or higher to lower value.

Scale Log or linear
Sweep type Log, linear or list

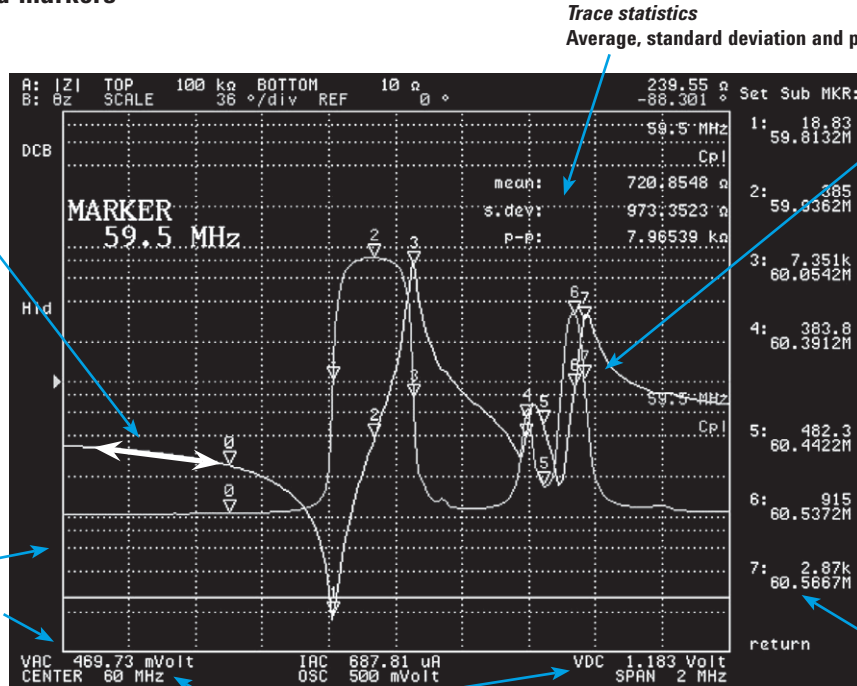

Manual sweep function
Iterative measurements at a user designated point. After measuring the overall performance of a device within a wide range, you can evaluate the characteristic at a specific point.

Marker functions
Peak search, next peak search, max/min search, bandwidth search, and other marker

7 sub markers
Measurement and frequency data are displayed as sub marker soft key labels.

Three multi-trace modes for comparison evaluation

Superimpose trace (accumulate) mode
This mode is used to observe an inter-mittent event or a change in the characteristic performance of a device over time.

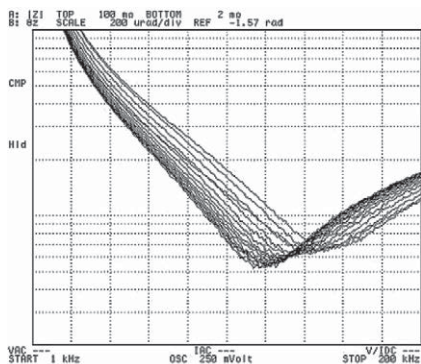

Accumulation of resonance vs. temperature data for a ceramic capacitor

List sweep mode

Superimpose and compare measurement data on the same display by setting the list sweep segments to the same frequency range with different DC bias or test signal levels. Markers can be used on each trace.

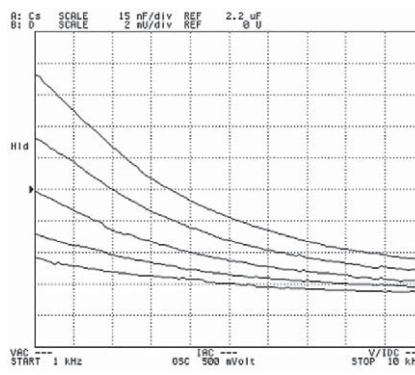

Capacitance variations of ceramic capacitor (2.2 μ F) with high permittivity measured by stepping the test signal level from 0.1 V to 0.9 V in 0.2 V steps (five list sweep segments)

Data/Memory trace

A data trace and a memory trace are available at each channel. The underlying data can be saved as the memory trace. Some simple calculations are possible with data math functions.

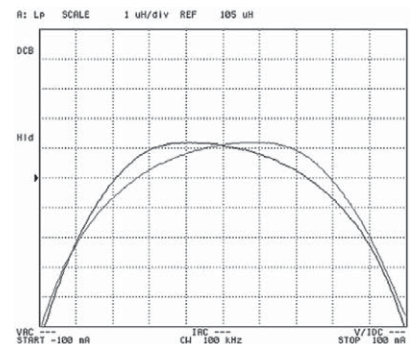

Inductor DC dependency characteristics (100 μ H inductor at 100 kHz) UP and DOWN DC current bias sweep from -100 mA to +100 mA. Hysteresis is observed.

Easy, automatic measurement system configurations

Labs today often require system configurations in which test instruments interact with other instruments or handshake with external computers.

Agilent 4294A functions that support efficient systems:

- Instrument BASIC programming function for automatic measurement or external measurement instrument control without an external computer.
- List Sweep function for measuring only at desired points.
- Limit line function for Go/NoGo testing.
- Built-in 10 Mbyte non-volatile memory to quickly save/recall data/setup.
- Two types programmable digital I/O port (24 bit and 8 bit) for data transfer with external device such as sensor, and for external device control.
- LAN interface for networking with computers.

The LAN I/F dramatically expands the ability to share files, data, or instrument control. Measurement setup, result, and graphics files can be transferred via FTP (File Transfer Protocol) to or from the instrument.

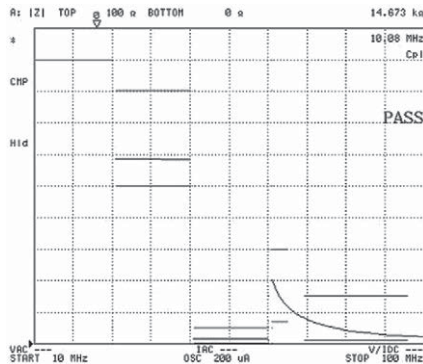

Limit test

Limit test of PIN diode impedance. 4 segment list sweep with different DC bias voltages and different frequency ranges using constant DC bias voltage (ALC) mode.

IBASIC programming function

Instrument BASIC (IBASIC) is a programming language developed from BASIC programming language. The keystroke recording function helps to easily develop automatic measurement program with front panel keys. When a key is pressed, the GPIB command corresponding to the key is automatically recorded in the program. Writing or editing programs the old-fashioned way is made easier with the mini-DIN key board.

One touch IBASIC program execution

When you press the softkey with the file name of an IBASIC program saved in either internal memory or floppy disk, the program is automatically downloaded and executed. Once customized IBASIC programs are developed, quick measurement and data analysis is possible because each program works as if it is a built-in function.

Agilent 4294A interfaces

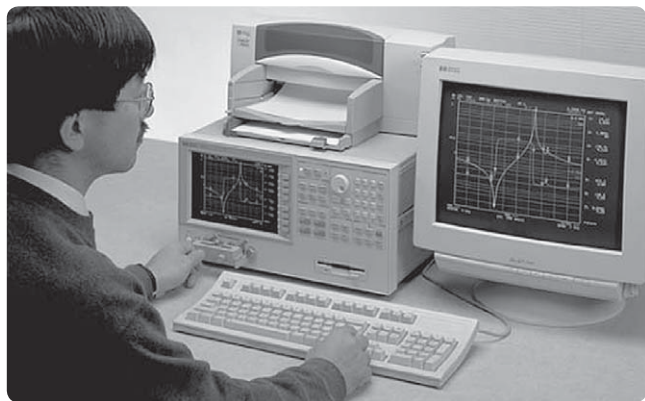
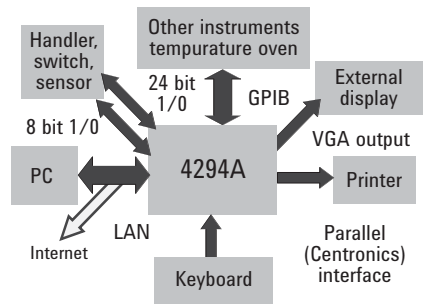

A feature with high visibility

The Agilent 4294A has VGA output on the rear panel. Automatic test or component adjustment in production line or QA test can easily be performed with a large external monitor.

Accessories for various measurement needs

Agilent 42941A impedance probe

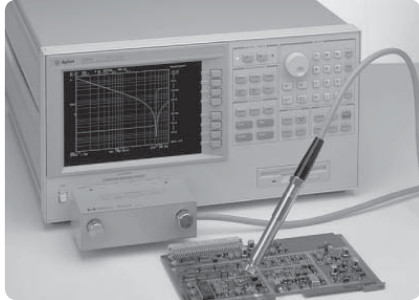

The 42941A impedance probe enables in-circuit impedance measurement of electronic circuits or components. Grounded devices can also be measured.

Key specifications

Frequency: 40 Hz to 110 MHz

DC BIAS: 0 V to ± 40 V

Operation temperature range:

-20 °C to 75 °C

Basic impedance accuracy: $\pm 0.8\%$

Agilent 42942A terminal adapter

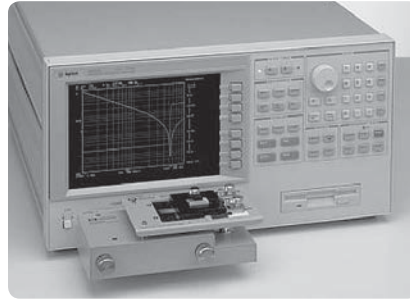

The 42942A terminal adapter converts the four-terminal-pair port configuration to an 7-mm port. This adapter permits the use of familiar 7-mm test fixtures.

Again, grounded measurement is available.

Key specifications

Frequency: 40 Hz to 110 MHz

DC bias: 0 V to ± 40 V

Operation temperature range:

0 °C to 40 °C

Basic impedance accuracy: $\pm 0.6\%$

Material test fixtures

Use of a dielectric material fixture such as the Agilent 16451B or 16452A allows accurate dielectric material measurement. Permeability of magnetic materials can also be evaluated with the Agilent 42942A and 16454A magnetic material test fixture. Automatic measurement and permittivity/permeability analysis can easily be performed by using built-in IBASIC or by I/O to a computer where the analysis can be performed.

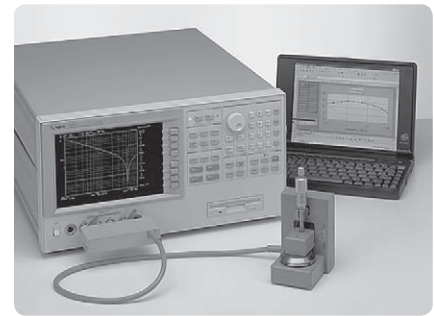

Other accessories

When a DUT cannot be positioned near the instrument, a four-terminal-pair extension (Agilent 16048G: 1 m or 16048H: 2 m) can be used to extend the test station to the DUT. These Agilent extension accessories operate over the entire frequency and temperature range (40 Hz to 110 MHz, -20 °C to $+150$ °C) of the 4294A.

Ordering Information

Agilent 4294A precision impedance analyzer

Accessories included:

- 100 Ω load resistor for four-terminal-pair extension
- Sample program disk
- Power cable

Options:

- **4294A-800** Standard frequency reference
- **4294A-810** Add mini DIN keyboard
- **4294A-1D5** High-stability frequency reference
- **4294A-ABA** English localization
- **4294A-ABJ** Japanese localization
- **4294A-OBW** Add service manual
- **4294A-1A7** ISO 17025 compliant calibration
- **4294A-1CM** Rack mount kit
- **4294A-1CN** Front handle kit
- **4294A-1CP** Rack mount and front handle kit

Accessories available:

- **Four-terminal-pair test leads (16048G/16048H)**

1 m/2 m four-terminal-pair port extension cable with BNC connectors.

Frequency: 40 Hz to 110 MHz

DC bias: 0 V \pm 40 V

Operation temperature range:

-20 $^{\circ}$ C to 150 $^{\circ}$ C

Cable length: 1 m (16048G)

2 m (16048H)

Accessories available:

- **42941A impedance probe kit**

Convert four-terminal-pair port configuration to a one-port probe.

Furnished items:

- Probe and Four-terminal Pair Connection Block
- Pin probe
- Spare pin set (includes 3 spare pins)
- 3.5 mm SHORT
- 3.5 mm LOAD (50 Ω)
- BNC adapter
- Clip lead
- Ground lead
- Carrying case
- Operation and Service Manual



42941A Impedance probe kit



Impedance probe with connection block

Agilent 42942A terminal adapter

Converts four-terminal-pair port configuration to an APC-7 port.

Furnished items

- Terminal adapter
- 7 mm OPEN*
- 7 mm SHORT*
- 7 mm LOAD (50 Ω)*
- Operation and Service Manual

* Furnished with Option 42942A-700

Option:

42942A-700 Add 7 mm open/short/load set

Items included:

- 7 mm open reference
- 7 mm short reference
- 7 mm 50 Ω reference
- Operating manual/data sheet



42942A Terminal adapter (set) including option 42942A-700



Terminal adapter

Fixtures

Fixtures for leaded components

16047E (DC to 110 MHz)

For leaded components. This fixture features the capability to clamp the leads between the electrodes and adjust the pressure. A guard terminal is provided for three port device measurements.

Accessories provided:

Shorting plate
4294A mounting tool

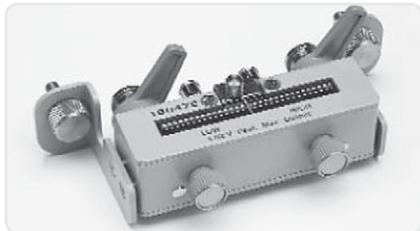

16047A/D (DC to 3 MHz/40 MHz)

For leaded components. These fixtures use spring actuated clamps to hold device leads.

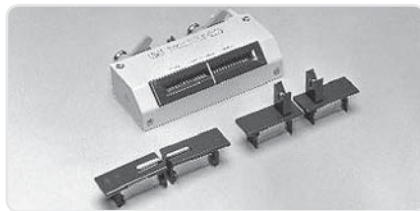

16092A (DC to 500 MHz)

For leaded or surface mount (SMD) components. Attachments for leaded or SMD are provided. Note: The 42942A adapter is required.

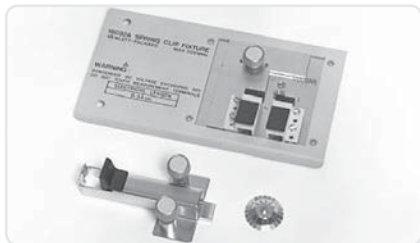

16093-65003/4 (DC to 250 MHz)

This is a binding post type fixture. Note: The 42942A adapter is required.



Fixtures for SMD

16034G (DC to 110 MHz)

0201 (0603) to 1206 (3216) size components. Maximum dimensions: 5 mm (L) x 1.6 mm (W) x 1.6 mm (H)

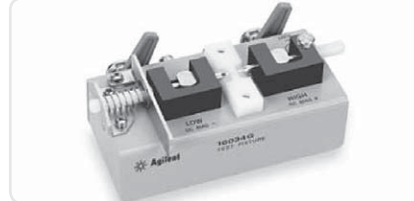

16034E (DC to 40 MHz)

0603 (1608) or larger size components can be measured. Maximum dimensions: 8 mm (L) x 10 mm (W) x 10 mm (H)

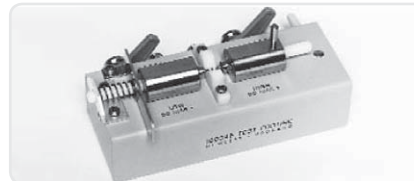

16196A/B/C/D (DC to 3 GHz)

Coaxial fixture specialized for the following SMD sizes:

16196A: 1608 (0603)

16196B: 1005 (0402)

16196C: 0603 (0201)

16196D: 0402 (01005)

Note: The 42942A adapter is required



16044A (DC to 10 MHz)

Features a Kelvin connection suitable for low impedance measurement of 0603 (1608) size components or larger. Maximum dimensions: 8 mm (L) x 8 mm (W) x 3 mm (H)

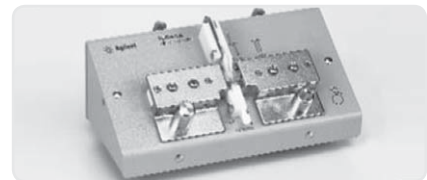

16197A (DC to 3 GHz)

This fixture is for bottom electrode components. Applicable size is 0201 (0603) to 1210 (3225).

Note: The 42942A adapter is required.

* Option 16197A-001 is required for 0201 inch/0603 mm.

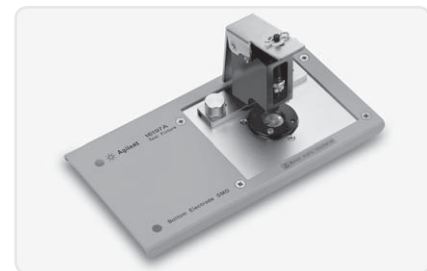

16192A (DC to 2 GHz)

This fixture uses side electrode contacts 0603 (1608) or larger size components. Note: The 42942A adapter is required.

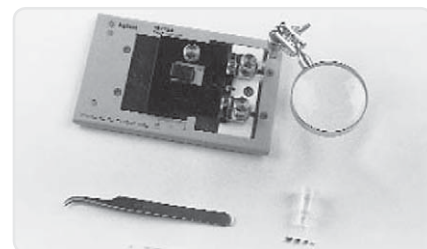

Material test fixtures

16451B

A dielectric material test fixture, with parallel plate electrodes.



16452A (20 Hz to 30 MHz)

Dielectric test fixture for liquid material.

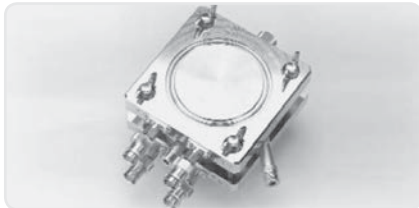

16454A (1 MHz to 1 GHz)

Fixture for toroidal magnetic material. Note: The 42942A adapter is required.



Special purpose accessories

16065A (50 Hz to 2 MHz)

External DC bias adapter to ± 200 V. Note: For leaded components.

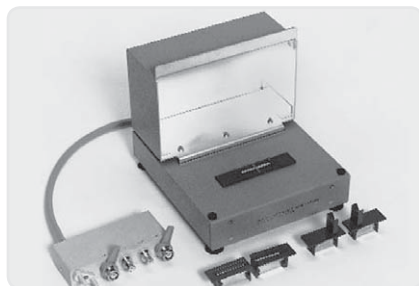

Web Resource

www.agilent.com/find/impedance

Remove all doubt

Our repair and calibration services will get your equipment back to you, performing like new, when promised. You will get full value out of your Agilent equipment throughout its lifetime. Your equipment will be serviced by Agilent-trained technicians using the latest factory calibration procedures, automated repair diagnostics and genuine parts. You will always have the utmost confidence in your measurements. For information regarding self maintenance of this product, please contact your Agilent office.

Agilent offers a wide range of additional expert test and measurement services for your equipment, including initial start-up assistance, onsite education and training, as well as design, system integration, and project management.

For more information on repair and calibration services, go to:

www.agilent.com/find/removealldoubt

Product specifications and descriptions in this document subject to change without notice.



Agilent Email Updates

www.agilent.com/find/emailupdates

Get the latest information on the products and applications you select.



Agilent Direct

www.agilent.com/find/agilentdirect

Quickly choose and use your test equipment solutions with confidence.

www.agilent.com

For more information on Agilent Technologies' products, applications or services, please contact your local Agilent office.

The complete list is available at:

www.agilent.com/find/contactus

Americas

Canada	(877) 894-4414
Latin America	305 269 7500
United States	(800) 829-4444

Asia Pacific

Australia	1 800 629 485
China	800 810 0189
Hong Kong	800 938 693
India	1 800 112 929
Japan	0120 (421) 345
Korea	080 769 0800
Malaysia	1 800 888 848
Singapore	1 800 375 8100
Taiwan	0800 047 866
Thailand	1 800 226 008

Europe & Middle East

Austria	01 36027 71571
Belgium	32 (0) 2 404 93 40
Denmark	45 70 13 15 15
Finland	358 (0) 10 855 2100
France	0825 010 700*
	*0.125 €/minute
Germany	07031 464 6333
Ireland	1890 924 204
Israel	972-3-9288-504/544
Italy	39 02 92 60 8484
Netherlands	31 (0) 20 547 2111
Spain	34 (91) 631 3300
Sweden	0200-88 22 55
Switzerland	0800 80 53 53
United Kingdom	44 (0) 118 9276201

Other European Countries:

www.agilent.com/find/contactus

Revised: October 1, 2008

© Agilent Technologies, Inc. 1999, 2000, 2003, 2004, 2008
Printed in USA, November 13, 2008
5968-3808E



Agilent Technologies